



compute's



adventure
GAME
player's
handbook

**COMPLETE
SOLUTIONS**

TO 37

**POPULAR
ADVENTURE
GAMES**

raymond lueders

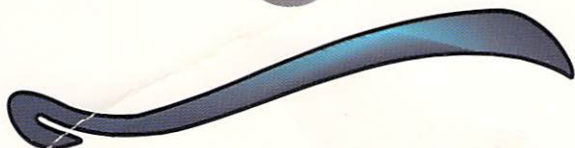
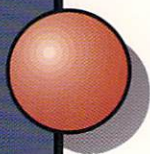

**COMPUTE'S
ADVENTURE GAME
PLAYER'S HANDBOOK**

RAYMOND LUEDERS

COMPUTE BOOKS
GREENSBORO, NORTH CAROLINA

To the angels of my heart,
Carolyn and Rachel Anne

Editor: Eddie Huffman

Copyright 1993, COMPUTE Publications International Ltd. All rights reserved.

Reproduction or translation of any part of this work beyond that permitted by Sections 107 and 108 of the United States Copyright Act without the permission of the copyright owner is unlawful.

Printed in the United States of America.

10 9 8 7 6 5 4 3 2 1
ISBN 0-87455-289-3

The author and publisher have made every effort in the preparation of this book to ensure the accuracy of the information. However, the information in this book is sold without warranty, either express or implied. Neither the author nor COMPUTE Publications International Ltd. will be liable for any damages caused or alleged to be caused directly, incidentally, or consequentially by the information in this book.

The opinions expressed in this book are solely those of the author and are not necessarily those of COMPUTE Publications International Ltd.

COMPUTE Books, 324 West Wendover Avenue Suite 200, Greensboro, North Carolina 27408, is a General Media International company and is not associated with any manufacturer of personal computers.

Contents

Preface	v
Conquests of the Longbow	1
Leisure Suit Larry V	20
Rise of the Dragon	35
Heart of China	48
Leather Goddesses of Phobos 2	61
EcoQuest	74
Star Trek	87
Space Quest IV	101
Space Quest V	114
Willy Beamish	127
Dark Seed	139
Mixed-Up Fairy Tales	153
King's Quest V	158
King's Quest VI	172
Les Manley in: Lost in L.A.	193
Quest for Glory III	204
Martian Memorandum	217
The Dagger of Amon Ra	228
Police Quest 3	246
Indiana Jones	265
The Legend of Kyrandia	291
Monkey Island 2	308
Alone in the Dark	324
The Lost Files of Sherlock Holmes	335
Rex Nebular	349
Amazon	362
Ultima Underworld	375
Ultima Underworld 2	398
Spellcasting 301	413
Ringworld	427
Eric the Unready	433

The Prophecy 442
Inca 452
Gobliins 2 459
Lost Secret of the Rainforest 468
The 7th Guest 477
Freddy Pharkas 488

PREFACE



old onto your joysticks folks—you're about to embark on a journey that will transport you to a realm where gallant warriors are born. This place of wisdom transforms losers into winners, cowards into heroes, and paupers into rich people. You too can visit this widely sought realm by venturing through the pages of this book. Never again will you be tied up for months confronting unsolvable puzzles; never again will you need to purchase a single-game hint pamphlet for every computer game you buy; and never again will your telephone bill soar through the roof because of those ungodly expensive 900 numbers. Why? Because I've done all that painstaking work for you.

The Adventure Game Handbook took more than two gut-wrenching years to complete. During the developmental stage, each game was purchased, tested, played, replayed, and thoroughly analyzed by yours truly. After biting my fingernails to the bone and breaking so many No. 2 pencils that I began to worry about the forests, I switched to an industrial-strength Paper Mate 420 stainless steel pen and scrawled my ideas and format styles down on paper. I then scrambled through thousands of notes and endless doodles and somehow managed to organize this information. Then the serious market research began. Understanding that the adventuring world is crammed full of all kinds of different people—from youngsters to grandparents, inexperienced players to masters—*The Adventure Game Handbook* was written using a unique strategy that targets both the novice player (who has nobly stepped forth into the addictive world of computer adventuring) and the master adventurer (who has embarked on the latest quest seeking a quick hint from an elaborate reference manual). The three major features that make this book so unique follow.

First, and most importantly, *The Adventure Game Handbook* is the most elaborate hint book on adventure/role-playing games available to the public. Because it contains thousands of hints for a multitude of games (from various manufacturers), it's an essential asset for every adventurer. And since this volume was *not* endorsed by any specific game-writing organization, it contains

an unbiased authors' critique of each game. In other words, if a game *knocked my socks off*, or totally *bombed*, you can count on me for an honest opinion.

Second, the sectional format of this guide is vital for quick clue retrieval. Each game is individually indexed and includes an elaborate scenario, an author's critique, a system-availability list, a feature list, a location-of-objects list, and map illustrations. By constructively using this information, you'll find that this book is a comprehensive buyer's guide as well as the most elaborate hint book available to the public.

And finally, upon completing this volume (or even a single page), you'll have learned many secrets and cheat modes heretofore known only to the computer programmers themselves! Need I say more?!

SO YOU WANT TO BE AN ADVENTURER

Since you're reading this section, I can safely assume that you're a novice gamer intelligently preparing yourself with the ultimate armament to tackle the belligerent world of computer adventuring. (If you're an experienced adventurer, you can skip straight to those valuable hints). Let's start at the beginning by answering the question, What is an adventure game? An adventure game really isn't a game at all: It's an elaborate story (written for the PC) in which you take control of the lead character(s). Your specific actions will decide whether or not you proceed in the story. Some adventures are long, others short; some are sophisticated, others quite simplistic. The very complex adventures combine video digitization of actual live people and real places with extensive musical scores, digitized speech, and

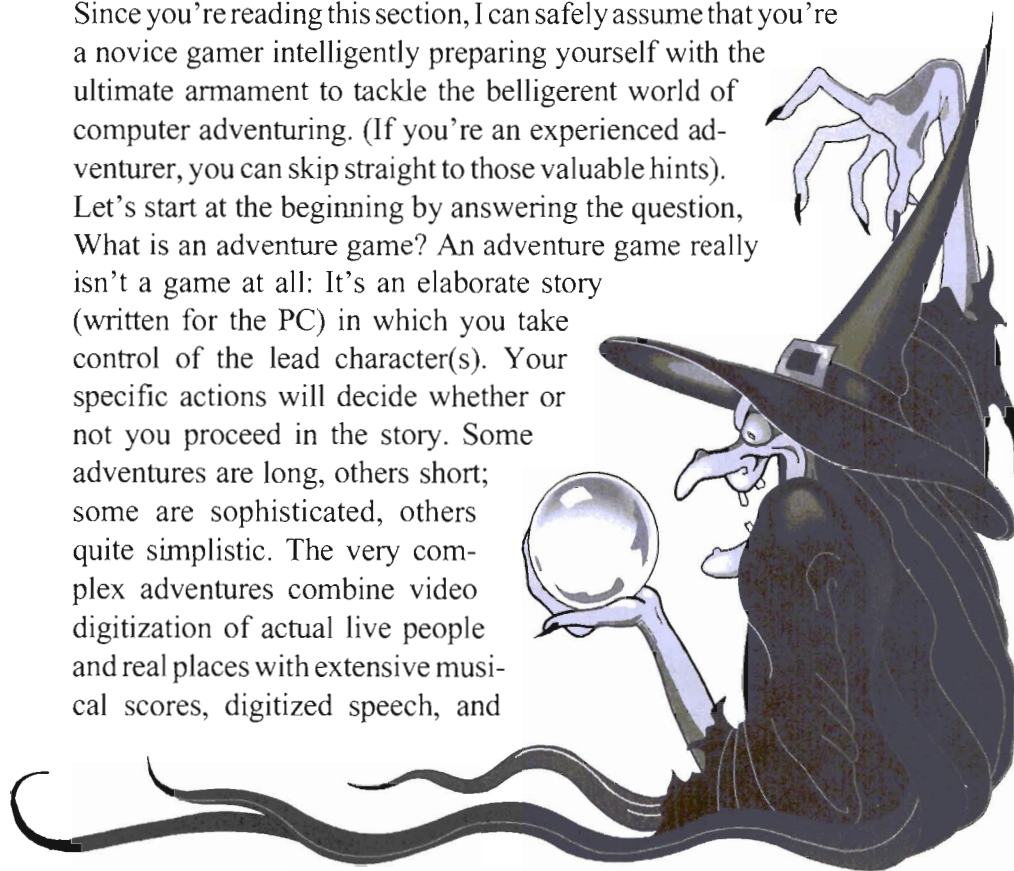

sound effects. This combination generates games that are movie-like in both visual effect and sound reproduction. The single aspect true to all adventure games is that you have complete control of the main character. You decide where that character goes, what he/she/it does, and even what that character says. As the story unfolds, you must solve puzzles, find and use items, pontificate with others, and travel to specific locations to complete the journey successfully.

As you've probably already guessed, each adventure contains a world of its own—from the beaches of Honolulu to the farthest star in space, a new world awaits you in every quest you tackle.

- Control the starship *Enterprise* and visit alien worlds as you assume the role of Captain Kirk in the *Star Trek* quest.
- Bust lawbreakers playing the role of police officers in the *Police Quest* series.
- Go girl-hunting in the *Leisure Suit Larry* series.
- Play the role of a magician, fighter, or thief in the medieval adventure *Quest for Glory*.
- Careen across the galaxy in the *Space Quest* series.
- Prowl through a haunted mansion in the multimedia drama *The 7th Guest*.

Whichever realm tickles your fancy, one thing's certain: Once you become an adventurer, you're hooked for life!



CHAPTER 1

CONQUESTS OF THE LONGBOW

GRAPHICS:	☆☆☆☆	STORY LINE:	☆☆☆☆
ARCADE:	☆☆☆	INTERFACE:	☆☆☆☆
DIALOGUE:	☆☆☆☆	AUDIO:	☆☆☆
ANIMATION:	☆☆☆☆	LENGTH:	☆☆☆☆

OVERALL ANALYSIS: ☆☆☆☆

SYSTEMS

- MS-DOS IBM-PC/Tandy & Compatibles
- Amiga
- Macintosh

FEATURES

- More puzzles than any previous Sierra adventure game.*
- Arcade sequences with adjustable levels of difficulty, including auto-win.*
- Original soundtrack based on medieval music styles, using the sounds of period instruments.*
- A no-typing, point-and-click interface.*

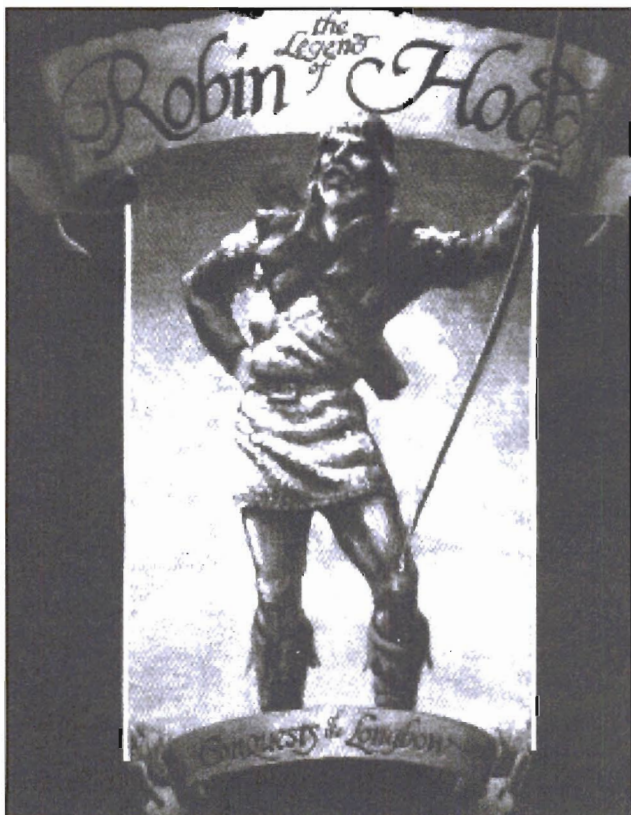

SCENARIO

Aye, 'tis a wonderful day to tarry within the realm of Sherwood Forest and banter with thy trustworthy merry men. Alas, amongst gibing the infidels and deciding how best to dole the hapless, mercy on thee if thou steps forth into an almighty quest such as this without being a crack shot. Mayhap if thou lacks strength and marksmanship, thy lively wit shall be utterly humiliated—or worse, thy own heart pierced by a yeoman's longsword. Alas, full-bellied outlaws

like ourselves must never tire within this quest—especially since brief arcade sequences have been strategically sprinkled within the story. By arcade, I am referring to the sections requiring reflexes, timing, and visual skills. If thy blood curdles from arcade, simply by pass these sequences by adjusting the arcade lever (obtained through the computer icon) to minus. But keep in mind, my curry friend, if thou avoidest arcade sequences, thou shall be denied the game points acquired from completing them. Unlike with the original Robin Hood fable, Lady Marx of Sierra On-Line has rewritten this popular story—giving an old legend a new, powerful punch! Let's all encourage Marx to design a sequel to a legend that yet boasts no sequel. I tip my hat to Lady Marx for giving us a 4-Star adventure game!



Christy Marx

WALK-THROUGH

DAY 1: THE CAVE

Using the eye cursor, examine the cave and the items within it. Locate the horn and use the hand cursor to retrieve it. Also, you'll need some money (and who doesn't?) to complete this quest. Your money chest is at the west end of the cave. Use the inventory icon (the pouch) to see how much cash you have.

THE CAMPSITE

Exit the cave and converse with your men. After Little John and Will Scarlet stroll off the screen, pontificate with the remaining two men. If you're hungry, partake in Tuck's feast of fresh salmon.

Remember the horn you found in the cave? Are you wondering what it's used for? Click on the inventory icon and then on the horn, then click the horn on Robin.

Leave the campsite in the same direction as Will (northeast). Walk due north and you'll arrive at the shooting glade. If you have trouble finding it, start back at the campsite and try again—eventually you'll find it.

THE SHOOTING GLADE

The purpose of the shooting glade is strictly to sharpen your archery (arcade) skills. Begin, naturally, by talking to the two men present—especially young Simon. After the conversation turns bland, it's time to let some arrows fly. The garlands are your targets. Click the longbow cursor on the near-



est tree or garland, take aim, and fire. Now click on your bow-hand to nock another arrow. Continue shooting while keeping an eye on the flag (it bears wind speed and direction; compensate for these two variables as you shoot).

Hint: By clicking the eye cursor on a garland, you 'll see a close-up view of your shots.

If you think you've got what it takes to be as good a marksman as the almighty Robin Hood, increase the target range by choosing a more distant garland.

After sharpening your archery skill to its utmost potential (spend as much time as you want), click the walk cursor anywhere on the screen. Walk south until you reach the outlaw camp.

WATLING STREET OVERLOOK



Do you remember where Little John went? He went to Watling Street Overlook—it's time to go find him. After saving the game, walk due west three screens and you'll reach the overlook. If you get lost, restore the game and try again: The trick is to leave the campsite at the proper location—due west.

Hint: Once you've discovered Watling Street Overlook, its icon will appear on the auto-travel map.

After reaching the overlook, wait for Little John. Once he arrives, pay close attention to what he tells you. Immediately after he leaves, save the game.

Wait for the Sheriff's man to appear. Look at him. Confront him using the walk cursor. Talk to Jack and the peasant woman. To get help from your men, toot your horn. Click the hand cursor on Jack; if that doesn't work, use your longbow. After freeing the peasant woman, venture throughout Sherwood Forest. Walk from scene to scene while looking at everything (i.e., trees, leaves, fallen logs, and anything else that looks interesting). After combing the woods to your satisfaction, go to the Widow's cottage. Travel one of two ways:

- By foot
- By teleportation

It's easier using the teleportation method. Click on the map icon (the icon containing the arrows). Use the eye cursor to identify specific locations. After locating the Widow's cottage (on the map), use the walk cursor to teleport to that location. Talk to everyone you see. Acquire as much information as possible from the Widow and her sons. After leaving this scene, you'll automatically return to the campsite and the day will end.

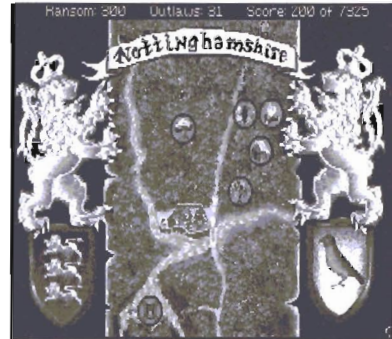

DAY 2: THE SLIPPER

To obtain the desperately needed slipper, you must find Lady Marian (she is somewhere within Sherwood Forest). Use the map icon to teleport to select locations. During your search, talk to everyone you meet—especially your own men.

Hint: *To get the information you really want, you may need to talk to a person more than once. Be persistent!*

Eventually, you'll encounter Lady Marian—and a deranged vagrant attacking her. One blow from the Monk's club could very well kill Marian. With a burning heart and the aim of a hawk, quickly nock an arrow, take aim, and kill the Monk (oh, and Robin, be careful not to strike Marian). If you succeed, Lady Marian will reward you with her slipper. Use the hand cursor to retrieve the slipper and to search the Monk's body.

Hint: *If you've committed an adventurer's blaspheme (i.e. forgetting to take the slipper), rap your knuckles with a wooden ruler! Now lend me your ears—one of thy merry men will roll his eyes and snicker a bit, then place the slipper in your cave.*

Blow the animal's bony outgrowth (the horn, silly—this isn't *Leisure Suit Larry*, for crying out loud) and you'll have survived Day 2. Way to go, Robin!

DAY 3: THE DISGUISE

Okay, you need to find Lobb at Cobbler's Square in Nottingham. And by giving him Marian's slipper, he'll aid in your quest. But how are you going to get into Nottingham dressed as Robin Hood? You can't—you'll need a disguise. Go to Watling Street Overlook and wait for a hunchbacked beggar to appear. Greet him with kindness and offer him ½-a-penny for his rags. Use the map icon to travel to Nottingham. Click the walk cursor on Cobbler's Square. Examine the surroundings using the eye cursor. Talk to the tailor woman. Walk through the east doorway (this is where the Cobbler lives and works). Talk to the Cobbler. Offer him Lady Marian's slipper and he'll give you pertinent information about King Richard, Queen Eleanor, Prince John, Lady Marian, and the treasure. Finally, he'll give you a silver comb that you must return to Marian in the Willow Grove upon the river. Leave Cobbler's Square by clicking the walk cursor on the south portion of the screen. Day 3 will now end.

DAY 4: THE SHERIFF'S MAN

Talk to Will at the campsite; he'll remind you that Little John went to the overlook. Travel to Watling Street Overlook. Intercept the Sheriff's man and the innocent poacher. Talk to Hodge (the Sheriff's man). Unfortunately, he remains set in his ways, compelling you to use force. Use your trusty longbow—and Robin, be careful not to strike the poacher.

THE WILLOW GROVE

After slaying Hodge, you must meet Lady Marian in the Willow Grove. Use the map icon to travel there. Talk to Marian. Give her the silver comb and she'll give you another assignment: retrieving a small scroll (from the Monastery) containing an outline of a hand. Click the half-emerald (which you received while dreaming of the spiral

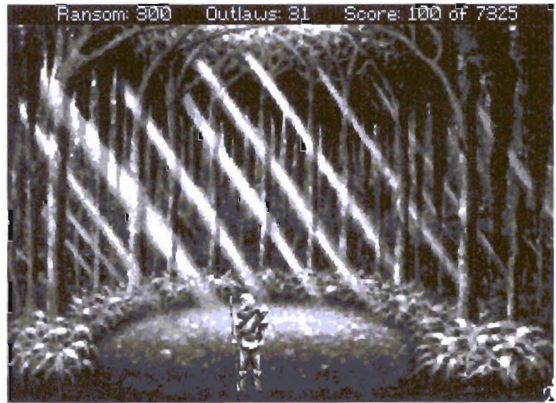

dance) on Lady Marian and she'll combine her emerald half with yours. After she departs, retrieve your weapon and walk south. Day 4 will now end.

DAY 5: FENS MONKS

Talk to your men, then travel to the Widow's cottage using the map icon. Upon your arrival, you'll be shocked to learn that the Sheriff's men have arrested the Widow's three dear sons. Before heading into town, you'll need another disguise. Use the map icon to travel to Watling Street Overlook. Save the game. Wait for a monk dressed in black to appear. When you see him, confront him. Attempt to slay him; he'll challenge you to a duel with quarterstaves. You can accept or decline his offer. If you decline, you'll lose 100 game points. If you accept (and win the duel), you'll gain 100 game points.

After dressing in the Fens Monk's clothing, click on the inventory icon to examine the whistle and pouch of gems. Use the map icon to travel to the Monastery in the Fens. To cross the Fens, blow the whistle made of marsh reed (it's in your inventory). A shallow draft boat will appear. To enter the boat, click the hand cursor on it. Talk to the Monk. Give him the whistle and the pouch of tokens (gems). The Monk will give you three riddles that you must answer correctly. Miss one riddle and you'll die, so it would be advisable to save the game. On pages 10-11 of the game documentation you'll find the answers to the Monk's riddles, which serve as the game's copy-protection.

THE MONASTERY

Enter the Refectory, located in the center of the Monastery, and you'll witness the Prior preaching to a pair of punks—I mean Monks. Converse with them. When the Prior leaves, quickly follow him into the northwest tower, which holds the torture chamber. Talk to the Dwarf. If you get no response, release the rope from which he hangs. Fulk, the King's Jester, will ask you to locate and return his lost verses, written on a ragged bit of scroll wrapped around a wooden cylinder. Leave the torture chamber and enter the southeast tower (the scribe room). Here you'll find the Prior studying Fulk's scroll. Before conniving a plan to steal Fulk's scroll, get the scroll of which Marian spoke (you're welcome for the reminder). To do this, walk to the rear of the room and find the scroll matching Marian's description.

***Hint:** You'll be notified by a window when you've found the correct scroll.*

To seize the Jester's scroll of verses, you must distract the Prior. Hey, do you see what I see? Why, it's a chalice of port! Click the hand cursor on the wine and it'll spill all over the Prior's freshly washed cowl—forcing him to leave the room. This would be an opportune time to snatch the scroll of verses and return it to its rightful owner.

After Fulk has his scroll, he'll lead you through a secret passageway. Hop onto the shallow draft boat using either the hand cursor or the walk cursor. To open the gate, you'll need to move (push) the gargoyles in the correct order. Numbering the sculptures in a clockwise direction, from 1 to 7, the answer is

❑ 1-5-3

After reaching dry land (and kissing the ground on which thee stand), Fulk will reward you with the Ring-of-Water and some other goodies. Wipe the sweat from your brow, since this completes Day 5.

DAY 6: ABBEY MONK

Take a deep breath, then use the map icon to travel to Watling Street Overlook. Wait for the Abbey Monk to appear (he'll be wearing a brown robe). Confront him. Click the hand cursor on him. Use his robe as a disguise.

Travel to town via the map icon, or walk south down Watling Street. Enter St. Mary's. Use the eye cursor to familiarize yourself with the Abbey. Enter the laundry room. Take the three robes. Enter the Refectory. Look at everything in the room. Talk to the Abbot and he'll send you to the pub for more ale. Take the empty cask from the table. Leave the Abbey and head toward Robin's favorite place, the Pub.

Enter the tavern. Use the eye cursor on everything and everyone in the room. Did you notice the old man sitting at the table to your right? Talk to him: He wants to play a game called Nine-Men's Morris. Before you accept his offer, save the game.

NINE-MEN'S MORRIS

Nine-Men's Morris is a very simple game to learn. The objective is to create as many *mills* as you can. A mill is created when three playing pieces are either in a horizontal or vertical plane (diagonal mills are illegal). Below is an example of valid mills.

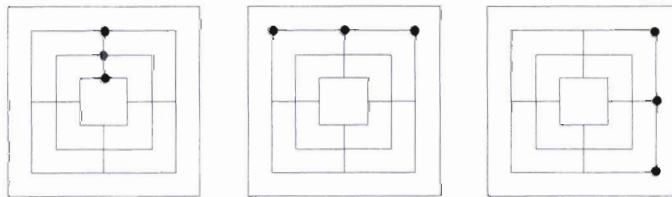

Valid Mills

After all your game pieces are placed on the playing board, you'll take turns sliding them back and forth, trying to create mills. Once you've created a mill,

CONQUESTS OF THE LONGBOW

you can remove one of your opponent's playing pieces. The game ends when either player has less than four chips remaining. Good luck!

After winning the game (and obtaining the purple amethyst), speak to the Innkeeper. Give him the empty cask and he'll allow you to return to the Abbey via the secret cellar tunnel. Walk to the rear of the Pub and click on the cellar door. If the Innkeeper isn't too busy, he'll open it for you. From within the cellar, click the hand cursor on the tap of the second barrel—the false front will open, allowing access to the secret tunnel. Crawl into the barrel to enter the tunnel. Walk east, north, then northeast. Click the hand cursor on the richly woven tapestry (which appears to be just another door). Once inside the Refectory, agree to drink with the Abbot. Place the amethyst into your cup.

***Hint:** Place the purple amethyst into your chalice to keep from getting drunk.*

After the Abbot falls into a drunken stupor, take the empty cask and search his body. Leave the Refectory and walk into the Abbot's bedroom; it's here where you'll find the puzzle box. Search under the pillows—the third one to be exact—and take the puzzle box. Now quickly leave the Abbey and hustle back to the Pub. Give the Innkeeper the empty cask and pay the Abbot's bill of 12 pennies. Click on the cellar door.

THE RESCUE OF THE WIDOW'S SONS

Enter the tunnel by clicking on the tap of the second barrel. Walk north and you'll reach a door. Peer through the keyhole and eavesdrop on the guard's conversation. After the guards leave, open the door. Place four pennies on the table. Exit the room. When the guards return, they'll find the pennies and leave for a second time. Reenter the room and use the hand cursor on the trap door located below the table. Toss the robes to the Widow's sons. After freeing them from the holding cell, enter the cellar.

Agree to enter the Pub

When the Sheriff pleads for a blessing, click the talk cursor on him. Now travel to the Widow's cottage and you'll obtain a golden net. Congratulations, Robin: You've survived Day 6.

DAY 7: THE SCROLL

Begin Day 7 by visiting Lady Marian in the Willow Grove. Give her the hand scroll and she'll divulge the secret of the Druid Code (hand code). She'll also tell you that you must present this scroll to the Queen's spy (at the Saturday Fair, in Nottingham) under one condition: The spy must identify the correct coat of arms.

***Hint:** Write down the coat of arms (it's different in every game). You'll find the coat of arms on pages 12-13 of the game documentation.*

Next, Marian will tell you about a green man who dwells in the ancient oak. Continue talking to Marian for additional clues.

THE WOOD SPRITE AND THE GREEN MAN

During your ventures throughout Sherwood Forest you may have noticed a tiny tree pixie jauntily prancing about. You can only catch this wood sprite with the golden net you received from the Widow.

Leave the Willow Grove. Comb Sherwood Forest in search of the wood sprite (you must remain in a particular scene for a short period before the little twerp will appear). Once you see him, get the golden net from inventory, take aim, and throw it at the shifty little character. Since wood sprites are very fast, you may need to do this a few times. After catching Pixie, he'll take you to the ancient oak tree. After the Green Man has spoken and returned to his abode, save the game.

***Hint:** Save the game—now!*

CONQUESTS OF THE LONGBOW

Summon the Green Man (by clicking the talk cursor on the oak) and he'll give you his riddles. If you fail his test, you must pay the ultimate price—death! Refer to p. 2 of the game documentation for the locations of the letters needed to answer the oak's riddles (copy protection).

Hint: Use the hand code to answer the oak's riddles.

The answers to the oak's riddles (in random order) follow:

- WOOD
- SNOW
- FEATHER
- BEEHIVE
- FUR
- COMB
- CHEESE
- COIN
- EYE

After successfully answering the oak's riddles, you'll inherit the power of the Druid trees. What this means is that you can hide from any dangers lurking within the forest, by finding a Druid Grove and spelling the correct name (of the Druid tree) using the hand code. Refer to pp. 8-9 of the game documentation for the names of the Druid trees.

DAY 8: THE SATURDAY FAIR

Day 8 begins as all others—at the outlaw's campsite. Since you've been hitting the hooch more than usual, your men will remind you that today is the day of the fair and the archery tournament. Use the map icon to travel to Watling Street Overlook. Eventually a sturdy-looking yeoman will appear. Confront him. Offer him money for his clothing. At this point, Robin will automatically summon his men. After changing into the yeoman's clothing, travel to the fair using the map icon.

There's much to do at the fair, but remember your objective—you must give

the scroll to the Queen's spy disguised as a scholar. There are many so-called scholars roaming about, so be careful to give the scroll to the correct spy. After presenting the scroll to the correct scholar, he'll offer you a reward (which you may accept). While at the fair, talk to everyone you meet. You may even find the designer of *Conquests of the Longbow* somewhere among the crowd. If you find Lady Marx, she'll reward you in a strange way. Just remember to enjoy yourself—it's a fair, after all.

Hint: *To gain additional game points, give the beggar some of your loose change.*

THE TOURNAMENT

Enter the tournament by walking due west. Since this is a very difficult arcade sequence, I suggest saving the game and/or adjusting the arcade lever to the appropriate setting.

Note: *The arcade lever can be adjusted using the computer icon. If you wish to skip this arcade sequence, move the lever to minus (remember, you must split the Master's arrow to win).*

After paying the whopping entry fee, the contest begins. It's similar to the shooting glade, so keep an eye on the flag—the wind will affect the outcome of your shots. Good luck!

After winning the golden arrow, the day will end and you'll automatically travel to the campsite to celebrate with your men.

DAY 9: THE SHERIFF'S MEN

Day 9 begins (surprisingly enough) with a warning from one of your men: A sense of uneasiness lurks within Sherwood Forest. And for good reason—the

CONQUESTS OF THE LONGBOW

Sheriff's men are sweeping the woods in search of full-bellied outlaws like yourself.

Use the map icon to visit the Widow. Save the game. Enter the realm of Sherwood Forest with open ears. Search for a Druid Grove—only there are you safe from the Sheriff's men. Look closely at the leaves of the Druid trees and compare them to the illustrations on pp. 8-9 of the game documentation. When you hear the Sheriff's men approaching, use the ancient oak spell to elude the medieval battalion. To accomplish this, first click the hand cursor on Robin, then spell the italicized name of the Druid tree. This will temporarily transform you into that particular Druid tree. After eluding the Sheriff's men, you'll automatically transmogrify back into Robin.

Use the map icon to travel to Watling Street Overlook. A lapidary (jeweler) specializing in gem stones will appear. Talk to him, then threaten him using the hand cursor (DONOT use the longbow). If he resists, use the hand cursor on him again. Eventually he'll give in.

Now it's time to visit the Sheriff himself (gulp!). But before we put the cart before the horse, check inventory and notice the small, round wooden box containing rouge. Open the box and rub the rouge into your beard and eyebrows (you never know who might recognize you from the tournament).

THE SHERIFF AND THE CASTLE

Under your rouge disguise, travel to Nottingham. Approach the castle and speak to the guard. Talk to the Sheriff. Show him the gems you received from the jeweler. Naturally, his wife will take special interest in them. After the Sheriff agrees to *some* of your requests, angrily grab the gems from his desk. His wife won't like that, and she'll force her husband to fully comply with *all* of your requests. The game will now enter automatic mode. Sit back and enjoy (click the mouse button to advance the documentation).

DAY 10: THE PUZZLE BOX

Begin Day 10 by solving the puzzle box. Click on the inventory icon and look at the scroll you received from the King's jester. Use the hand cursor to open the scroll. You'll need to use the first letter of every name (sequentially) to find the

code to open the puzzle box. The code is

N-E-M-O-R-A-L-I-S

MARIAN'S RESCUE

With the Ring of Fire safely tucked away in inventory, it's time to save your love, Lady Marian. Realizing that you can't accomplish this feat alone, you seek the advice of your men.

Choose Little John's plan of rescue.

Once in town, visit the Pub. Talk to the Innkeeper several times. Eventually, he'll realize that it's Marian who'll fry at the stake. Enter the secret passageway via the second barrel. Walk east, north, then northeast to reach the tapestry. Enter the Abbey. Once inside, leave the Refectory by walking east. Walk to the center of the Abbey, then north to the chapel. When you reach the chapel, save the game. Also, if you haven't already done so, click on the inventory icon and retrieve the Ring of Fire. Click the ring on Robin. You'll notice doors to your left and right. Enter the hedge maze through either doorway. (Refer to the map of the hedge maze at the end of this chapter.) Wait for Little John's signal before rescuing Marian from the Abbot. After traveling to the Willow Grove, cure Lady Marian using the half-heart emerald. She'll then whisper a password:

TORCH

Note: The password may differ because of random generation.

DAY 11: THE TREASURE TRAIN

The Abbot's treasure train was spotted by the northernmost scouts! Summon your men. Discuss a plan of attack. Listen to each plan carefully:

CONQUESTS OF THE LONGBOW

- ❑ Choose Tuck's plan

The ambush will occur automatically, and you'll gain enough silver for the King's ransom (if you won the golden arrow, that is). This will end Day 11.

DAY 12: THE KNIGHT

Day 12 begins with some bad news: The Sheriff's mongrels are on the prowl again; deal with them first. Enter a Druid Grove and wait for the approaching men. Using the hand code, spell the Druid name.

Use the map icon to travel to Watling Street Overlook. There you'll encounter the Queen's Knight. Do you remember the password that Lady Marian whispered to you in the Willow Grove? Using the hand code, spell the password:

- ❑ TORCH

Do this twice and you'll realize that this guy's an impostor! Immediately nock an arrow and kill the perpetrator, then search his body and you'll find a letter sealed with the imprint of the Prior's ring. Summon your men. This concludes Day 12.

DAY 13: RESCUE OF THE QUEEN'S KNIGHT

Welcome to Day 13, the final day of the game. Summon your men. Travel to the Fens Monk Monastery and slip the Ring-of-Water on your finger. Speak to the Will-o-th'-Wisps floating above the marsh—they'll help you cross the Fens. When you reach the tower, exit the boat by clicking the hand cursor on the ivy. Examine the ivy and compare the leaves to those found on pp. 8-9 of the game documentation. Using the hand code, spell the Druid name of the vine. The Druid code is:

- ❑ GORT

The vine will double in both thickness and strength, allowing you to climb it safely. Inside the tower you'll encounter the Queen's Knight. You'll need to prove your

identity before he'll cooperate. Use the hand code to spell the password that Marian whispered to you in the Willow Grove:

- TORCH

LOCATION OF OBJECTS

- Ale Cask Abbey Refectory
- Amethyst Pub (Winning Nine-Men's Morris)
- Disguises Watling Street, St. Mary's
- Emerald Half-Heart Robin's Dream
- Fulk's Scroll Scribes' Room (Monastery)
- Gems Fens Monk and Jeweler on Watling
- Golden Arrow Tournament (Fair)
- Golden Net Widow
- Hand Scroll Scribes' Room (Monastery)
- Horn Cave
- Letter False Knight (Watling Street)
- Money Pouch Cave
- Puzzle Box Abbot's Bedroom (Under Pillow)
- Reed Whistle Fens Monk on Watling Street
- Ring-of-Fire Puzzle Box
- Ring-of-Water King's Jester (Fulk)
- Robes Laundry Room (Abbey)
- Rouge Jeweler on Watling Street
- Silver Comb Cobbler
- Slipper Random Location in Sherwood Forest

MAPS

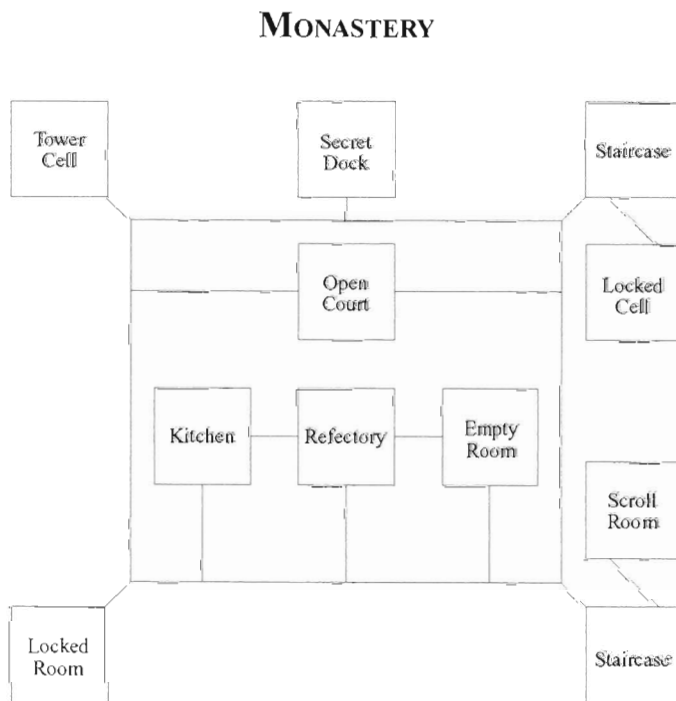
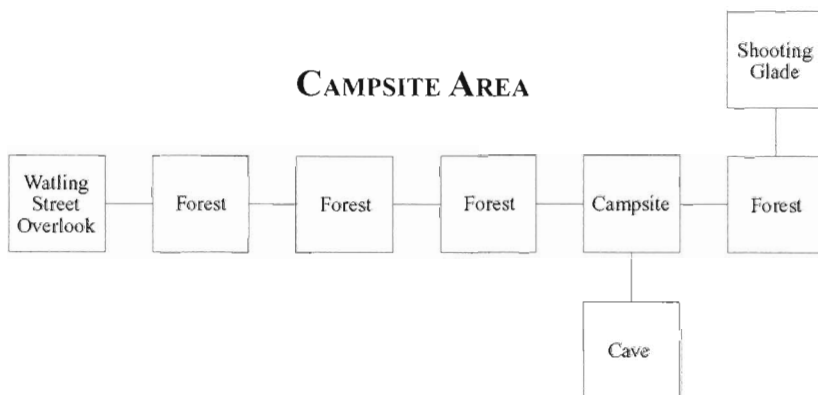

ST. MARY'S

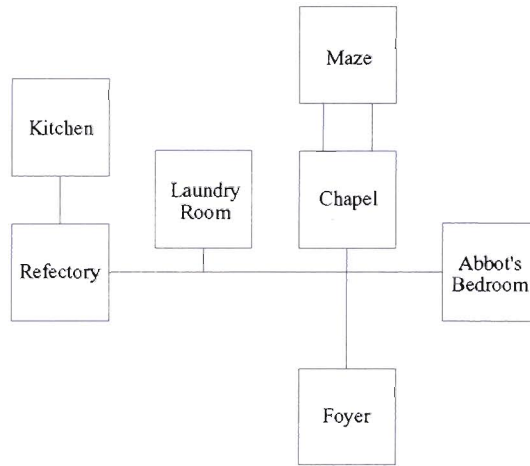

HEDGE MAZE

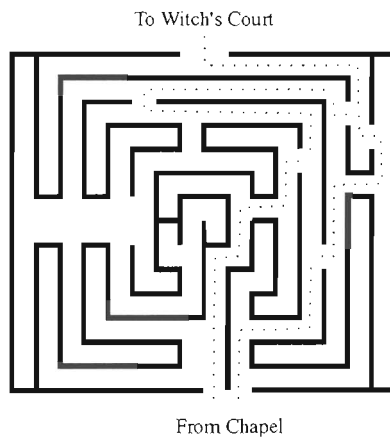

CHAPTER 2

LEISURE SUIT LARRY V

GRAPHICS: ★★★

STORY LINE: ★

ARCADE: ★

INTERFACE: ★★★★★

DIALOGUE: ★

AUDIO: ★★★

ANIMATION: ★★

LENGTH: ★★★

OVERALL ANALYSIS: ★★

SYSTEMS

- MS-DOS IBM-PC/Tandy & Compatibles
- Amiga
- Macintosh

FEATURES

- Original score by Hollywood composer Craig Safan: Emmy nominee, composer for the Cheers TV show, composer of movie scores for The Last Starfighter, A Nightmare on Elm Street 4, and many other films.*
- Hand-painted, digitized graphics in fabulous full color (including several of your favorite fleshtones).*
- No-typing, 'grobe-and-click' interface for quick-feel, one-hand action scoring.*
- Our most amazing and outrageous animation ever.*



SCENARIO

Hold onto your joystick, folks: That madman Al Lowe is on the loose again. He escaped from *Larry III* and surfaced in a gallery of goons that he likes to call *Larry V* (leaving us all to wonder about *Larry IV*). His latest sexy adventure can best be explained as totally and utterly naughty—parental discretion is highly advised! Consuming nearly 8-million bytes of hard disk space, *Larry V* isn't a scanty game by any means. In a game of such magnitude, there are many places to visit. To reach these destinations, you'll have access to a limousine and even an airplane. To pay for expenses, use your limitless gold credit card. Unlike its predecessors, this quest allows you to play more than just the role of good-

ol' Larry—you'll control Passionate Patti as well. Although this may sound great, changing back and forth between Larry and Patti can become quite confusing, especially if you aren't experienced in switching sexes on the fly. You should keep some notes—or have this book within arm's reach—to get through this one!

WALK-THROUGH

PPC

The game begins in the lobby of PornPropCorp. You'll hear (if you're one of the lucky few who own a soundboard) Larry's boss, Silas Scruemall, yelling for coffee. Click the eye cursor on the coffee maker. Get the coffee pot by clicking the hand cursor on it. Then Larry will automatically walk into the conference room and spill coffee on his boss. This will give Scruemall a very unusual idea: Send Larry across the United States to find and audition three of the most beautiful women in the country—you lucky dog, you.



Mr. Scruemall

Note: At this point, the game will ask if you want to protect it with a password. If you have children and you don't want them to play Larry V, enter a password. But keep in mind—if you forget your password, hang up your leisure suit.

Once you're back in the lobby, enter the videotape room by walking north, then west. Open the drawer farthest from the door and get the battery charger (a perfect device to keep your pocket-protector camcorder's battery fully charged). Get the three videotapes located next to the monitor at the lower-right portion of the screen. Find the degausser on the table next to the fuzzy dice. Click each tape on the degausser. Check the inventory icon and look at each tape (just to make sure that all the tapes have been properly degaussed). Click on the disinfectant to clean Larry's hands (and to gain additional game points). Find the 8-track tape player and play your favorite tunes. Exit the videotape room. Enter the lobby. Charge the battery of your camcorder by locating the wall outlet (next to the conference-room door). Plug in the battery charger. Place the camcorder on the charger. Wait a few seconds, then look at the camcorder to make sure the battery's fully charged. Retrieve the camcorder and the charger.

Hint: Full battery strength will give you five minutes of recording time.

Enter the filing room by clicking on the brown door. In this room you must obtain three resumes and a gold credit card. You'll find the resumes in the top drawer of the right file cabinet. The gold credit card is in the blue-and-white credit card imprinter located on the desk. Once you have these items, you can exit the filing room. Get a drink of water from the water cooler. Then look at the resumes by first clicking on the inventory icon and then clicking the eye cursor on each resume. Within each folder you'll find an object containing an important address.

If the battery of the camcorder is fully charged and you have the following items in inventory, you can leave PPC by walking east:

- Three resumes
- Three degaussed videotapes
- Napkin
- Business card
- Matchbook
- Camcorder
- Battery charger
- Gold card



Mr. Bigg

Click the hand cursor on the limousine and enjoy the ride. Watch the short animated sequence and, before you know it, you'll arrive at the airport.

THE AIRPORT

The first thing you'll need is a boarding pass. You can get one from the ATM machine located outside the terminal. To use this machine, click the hand cursor on it. Next, place the gold card in the slot. Click the hand cursor on

- New York*

To pass the off-disk copy protection, locate the correct code in the game

LEISURE SUIT LARRY V

documentation and enter it on the keypad (be sure to use the code corresponding to the location *and* departure time). After passing the off-disk copy protection, get the boarding pass. Oh, and Larry: Don't forget your gold card or you'll never finish this quest!

Hint: *Don't forget the gold card.*

Enter the terminal via the silver doors. Walk around the concourse. Locate the moving camera and flash your gold card at the lens. After the door opens, enter the waiting area. When the *Now Boarding* sign flashes, place the boarding pass in the ABM machine. Board the plane. Once aloft, read the magazine located in the seat pocket directly in front of Larry. Be sure to *read* the magazine instead of just placing it in inventory. Now the game character will change to Patti. Save the game.

PATTI IN THE LAB

When you change characters roles, you'll go through (among other things) a short animated sequence. After this sequence, you'll find yourself in the FBI lab playing the role of Passionate Patti.

Look at everyone in the lab, including those in the screen to the east. Also, be sure to write down the logging information the FBI agent gives you. In the version I played, the information was as follows:

- 556-2779
- BB-30,7
- 65493756
- Making Whoopy

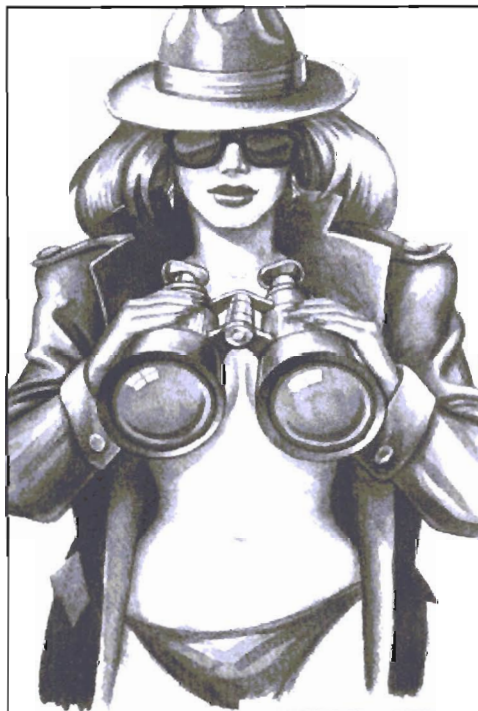

PASSIONATE PATTI DOES A LITTLE UNDERCOVER WORK

Walk through the east doorway. On your return, you'll need to collect some objects before leaving the lab. Find and retrieve the following items:

- DataMan (the tiny yellow electronic device)
- 2 ROM cartridges (DataPaks)
- Double-barreled brassiere (the *hooter-shooter*)

Leave the lab via the north doorway. Click the hand cursor on the limousine. Get the bottle of champagne from the liquor rack. Use the phone located to the right of Patti. Dial the number the FBI agent gave you:

- 556-2779

After speaking to Patti's boss, Inspector Desmond, click on the inventory icon and look at the DataPaks. Find the P.C. Hammer DataPak and click it on the DataMan. To communicate with Bobby, the limousine driver, show him the DataMan and you're off to K-RAP radio station. You'll now change character roles.

NEW YORK

Welcome to LaGuardia Airport. After a hasty departure, walk south into the terminal. Below the security camera is a charity canister where you'll find a quarter. Walk one screen west and read the sign above the purple door: It's an advertisement for the Checker Limousine Company. Copy down the phone number:

- 552-4668

Now, just to be safe, check the battery strength of the camcorder. If you need to charge the battery, do so now. Approach the pay phones by walking east. Use the first telephone (the others don't work) and dial the limousine service (552-4668). Leave the concourse by walking one screen west, then south. To enter the limousine, click the hand cursor on it.

To communicate with Bobbi, the sexy limo driver, show her the Hard Disk

LEISURE SUIT LARRY V

Cafe napkin that you found in Michelle's resume folder. Once you're on your way, get the blue appointment calendar book located on the seat just to the left of Larry. Open it and you'll find the following items:

- Money
- Credit cards
- Mutual fund account access codes
- Swiss bank account number

Save the game when you arrive at the Hard Disk Cafe. In the lobby of the cafe, locate the maitre d'. Talk to him several times. Eventually he'll give you a membership ticket. Get the ticket from the purple paper tape reader.

Did you read the magazine while on the airplane? In that magazine is a clue that will now prove useful. Find the music box in the lower-left corner of the screen. Click the membership tape on the music box to punch a few more holes in it. Now click the membership tape on the purple tape reader and you'll get into the cafe.

Sit at the table next to the heavy-set woman shoveling food into her mouth. Soon you'll see Michelle. Look at her, talk to her; get Michelle's attention anyway you can. If she slips through the doorway, click the membership ticket on the tape-reading machine. Finally you'll find yourself sitting but a few feet away from Michelle.

Talk to her until she allows you to sit at her table. Now **TURN ON THE CAMCORDER** (after inserting a blank videotape, of course).

Hint: Turn on the camcorder.

Give Michelle the appointment calendar book (which you found in the Limousine). What the heck—give her all the credit cards you found (except for your gold card). Talk to her again.

Use the lobby phone next to the maitre d' to call the limousine service. Do you remember the phone number? If not, I'll give it to you again:

❑ 552-4668

Hint: *Did you remember to turn off the camcorder?*

When you reach LaGuardia Airport, purchase a boarding pass for Atlantic City. Take both the boarding pass and the gold card from the machine. Enter the terminal. Walk west. Locate the electrical wall outlet and recharge the camcorder.

Hint: *Recharge the camcorder.*

When the battery's fully charged, carefully unplug the charger from the wall (and Lar: Don't get electrocuted). Remove the videotape of Michelle. Place a blank tape into the camcorder.

Flash the gold card in front of the security camera and have a seat in the VIP lounge. When the *Now Boarding* sign flashes, slip the boarding pass into the slot next to the door and you're off to New Jersey. Now the character role will change to Passionate Patti.

K-RAP RADIO

Welcome to K-RAP radio station. Find Krapper's office. Unfortunately, the door is locked. Look at the P.C. Hammer DataPak (inserted in the DataMan). There you'll find the code to open the office door:

❑ 45954

Note: *Because of random generation, this code may vary.*

Enter the code on the keypad. Click the hand cursor on the door to open it. Once inside Krapper's office, you'll need to unlock his desk. Find the desk key in the dirt of the humus plant (I think it's a humus). Unlock the desk and find the piece

LEISURE SUIT LARRY V

of blue stickum. Write this code down, because it's different in every game.

Hint: Write down the stickum code.

Look at the desk again and you'll find a folder marked *Personal*. Examine the folder and you'll see a person's name:

Julius

This is the evidence you've been looking for. Mr. Krapper will notice if the folder's missing, however, so you'd better find a way to copy it. Locate the ZeroZ 9000 copy machine. Click the folder on the copy machine to begin the copying process. After the machine explodes (which is unavoidable), return the folder to the desk, lock it, and return the key.

Walk through the west doorway. Click the hand cursor on the shower. After your embarrassing "showervator" ride, grab the yellow-and-purple clothing. Walk east and look for

Control Room B

Click the hand cursor on the keypad. Enter the code written on the blue stickum. Once inside the control room, get a blank reel-to-reel tape from the shelving unit along the back wall. Click the tape on the reel-to-reel machine located toward the left side of the room. Walk to the control console and click on it six (6) times. Once you have the correct setting, click on the tape machine to record the conversation.

P.C. Hammer will barricade you inside the control room. To get out of



PASSIONATE PATTI DOES A LITTLE UNDERCOVER WORK

the studio, you'll need to shatter the glass with a loud sound. Click the hand cursor on the control console to raise the volume. Click the talk cursor on the microphone and you're outta there.

When you're back in the limousine, use the telephone to contact Patti's boss, Desmond. Do you remember the number?

❑ 556-2779

Remove the P.C. Hammer DataPak from the DataMan and replace it with the Reverse Biaz DataPak. Show the DataMan to the limousine driver and you're off to the Shill Building. The game will now change characters.

ATLANTIC CITY

Welcome to Atlantic City, a miniature Las Vegas. After a hasty departure, walk south from the waiting room. Walk west until you find the slot machines. Try each machine until you find one that works. Once you receive a quarter, check the camcorder to make sure it's fully charged. If it is, walk to the center of the terminal and find the advertisement for the Tramp Limo Service. The number is

❑ 553-4468



Call the limousine service. Leave the terminal by walking west, then south. Show the limousine driver the book of matches from Tramp Casino. When you arrive at the boardwalk, walk east until you find Ivana Skates. Enter the store. Walk to the counter. Talk to Ivana. Give her the camcorder as a deposit for the skates. Now leave the store and find a bench. Put on the rollerblades. Save the game.

Skate around while looking for Lana. When you spot her, click the talk cursor on her. After getting Lana's attention, talk to her several times (if you can't find her, you

LEISURE SUIT LARRY V

screwed up: Restore the game and try again). Eventually she'll invite you to the mud wrestling show. Remove and return the skates (getting your camcorder). Then walk west until you reach Tramp Casino.

Before entering the casino, talk to Cheri (the blonde woman standing near the entrance door). She'll ask you a very simple question. If you answer her question correctly, she'll give you 10 silver dollars you can use inside the casino.

Enter the casino. Locate a vacant video poker machine and play poker until you win a minimum of \$500. To win at poker, you must save the game after each winning hand, then raise the bet. If you lose, restore the game and try again.

After winning at least \$500 (in silver Tramp coins) walk to the north end of the casino. Enter the arena. Pay the bouncer the participation fee. Tell him that you definitely want to partake in the mud wrestling tournament. Now **TURN ON THE CAMCORDER** and walk to an empty seat. Lana will ask you to enter the ring.

Hint: Turn on the camcorder.

To win the mud wrestling match, you must click on the body parts as fast as you can. When the match is over, turn off the camcorder and talk to the door attendant. He'll hail a limousine for you.

When you're back at the airport, purchase a boarding pass for Miami, Florida. Again, check the departure time and compare it to the departure times depicted in the game documentation. (Don't forget your gold card.) Now the character role will change to Patti.

DES REVER RECORDS

Welcome to the lobby of the Shill Building. Look at the elevator. Unfortunately, the elevator can only be operated by the sleeping guard. To wake him, click the talk cursor on him. Show him the DataMan with the Reverse Biaz DataPak installed.

From within the studio, locate the gold record hanging on the wall near the center of the room. Remove the record by clicking the hand cursor on it. Now

look at the stereo. Look at the buttons on the record player. To play the record, first place it on the platter. Click on the button labeled *Forward*. Place the stylus arm on the record and briefly listen to it. Click the *Stop* button. Click the button labeled *78*. Push the button labeled *Reverse* and again place the stylus arm on the record. With the record playing backwards, you'll hear subliminal messages. Push *Stop* and remove the record. Visit Reverse Biaz by clicking the hand cursor on the brown door displaying the letter *A*. Click the hand cursor on the red synthesizer three times. After the recording, you'll automatically enter the control room. Click the zipper icon on Reverse Biaz. He'll give you a small (ahem) cassette tape. Now the game control will switch back to Larry.

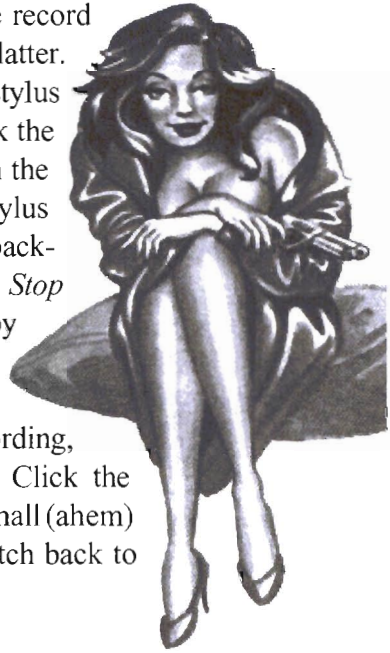

MIAMI

From the VIP lounge of the Miami Airport, walk south into the terminal. Walk one screen west and you'll find a cigarette machine. Check the coin return slot and you'll find a pair of quarters. Now RECHARGE THE CAMCORDER.

Hint: *Recharge the camcorder.*

After the battery's fully charged, remove the videotape of Lana. Insert a blank videotape into the camcorder. Look at the advertisements. You'll need to find two phone numbers this time:

- Just Green Cards
- The North Beach Limousine Rental

Call Just Green Cards and order a green card:

LEISURE SUIT LARRY V

❑ 554-1272

You can get a limousine by dialing

❑ 554-8544



Leave the terminal. Before getting into the limousine, find the envelope containing the green card (it's on the trash can next to the ATM machine). Enter the limousine. Show the driver Doc Pulliam's business card.

Welcome to Doc Pulliam's Dental Hygiene Heaven and Gym Dandy Gymnastics Center. Click the hand cursor on the door of the dental office. Once inside, check out the carpeting. Locate the lace doily on the far-right table. Place the doily on Larry's head, then talk to the receptionist. When Chi Chi arrives, click the eye cursor on her to get a better view. Then **TURN ON THE CAMCORDER**.

Hint: Turn on the camcorder.

Talk to Chi Chi. Give her the green card and she'll thank you in a strange yet wonderful way. After you finish with Chi Chi—or should I say after Chi Chi finishes with you?—go back to the dental office. Turn off the camcorder. Use the telephone to call the limousine service. Call the same service that brought you here.

When you're back at Miami Airport, purchase a ticket for Los Angeles. Unfortunately, while aboard the plane, the pilot's contract will expire and he'll leave his post. From within the cockpit, click feverishly on every button, switch, and lever you can find. If you're lucky, you'll find the auto-pilot control (the red button in the center of the control console). But how are you going to land the plane? Fortunately, the auto-pilot sequence will land the plane for you.

The character role will now change to Patti. When you're at the White House, shoot Julius with the *hooter-shooter* before he uses his gun. Congratulations, dude—you've just become a stud!

LOCATION OF OBJECTS

- Appointment Calendar Limousine
- Battery Charger PornPropCorp
- Blue Stickum Krapper's Desk
- Business Card PornPropCorp
- Camcorder PornPropCorp
- Cassette Tape Reverse Biaz
- DataMan FBI Laboratory
- Desk Key Plant (Krapper's Office)
- Doily East Table (Dental Office)
- Gold Card PornPropCorp
- Gold Record Des Rever Records (Lobby)
- Green Card Trash Can (Miami Airport)
- Hooter-shooter FBI Laboratory
- Magazine Airplane (Seat Pocket)
- Matchbook PornPropCorp
- Membership Ticket Hard Disk Cafe
- Napkin PornPropCorp
- Personal Folder Krapper's Desk
- Quarters Charity Cannister/Slot Machine
- Resumés PornPropCorp
- Rollerblades Ivana Skates
- Rom Carts FBI Laboratory
- Tramp Coins Blonde Woman at Casino Entrance
- Videotapes PornPropCorp



MAPS

K-RAP

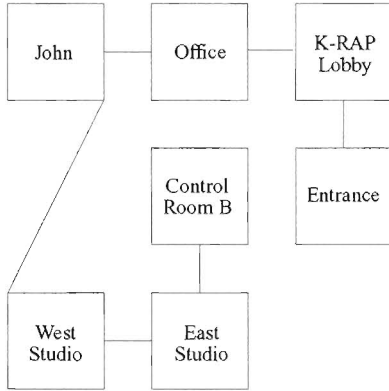

AIRPORTS

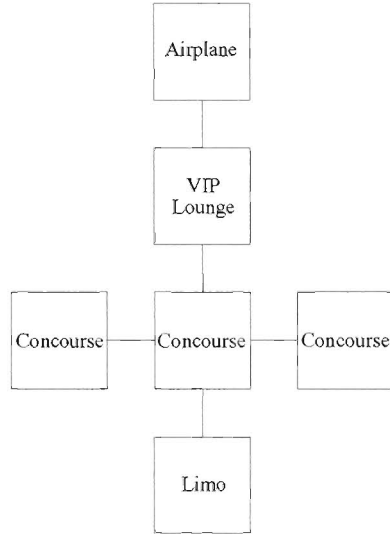

BOARDWALK

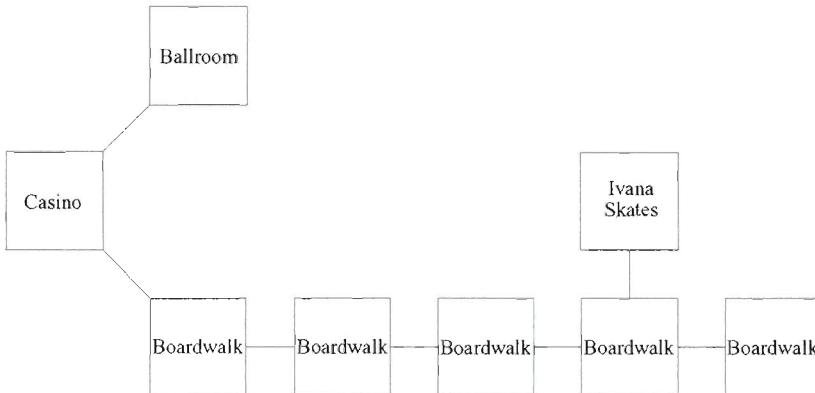

CHAPTER 3

RISE OF THE DRAGON

GRAPHICS:	☆☆	STORY LINE:	☆☆☆
ARCADE:	☆☆	INTERFACE:	☆☆
DIALOGUE:	☆☆	AUDIO:	☆☆
ANIMATION:	☆	LENGTH:	☆☆☆
OVERALL ANALYSIS: ☆☆			

SYSTEMS

- MS-DOS IBM-PC/Tandy & Compatibles
- Amiga
- Macintosh

FEATURES

- More than 8 megabytes of game data.*
- Hand-painted 256-color graphics create a stunningly realistic gaming environment.*
- Complex character intelligence and interaction add depth and dimension.*
- No-typing, point-and-click environment appeals to experienced and novice players alike.*
- Haunting original soundtrack and sound effects.*
- More than 85 scenes and locations, each with dozens of randomly generated animations, multiple story branches, puzzle solutions, and outcomes, making Rise of the Dragon infinitely replayable.*

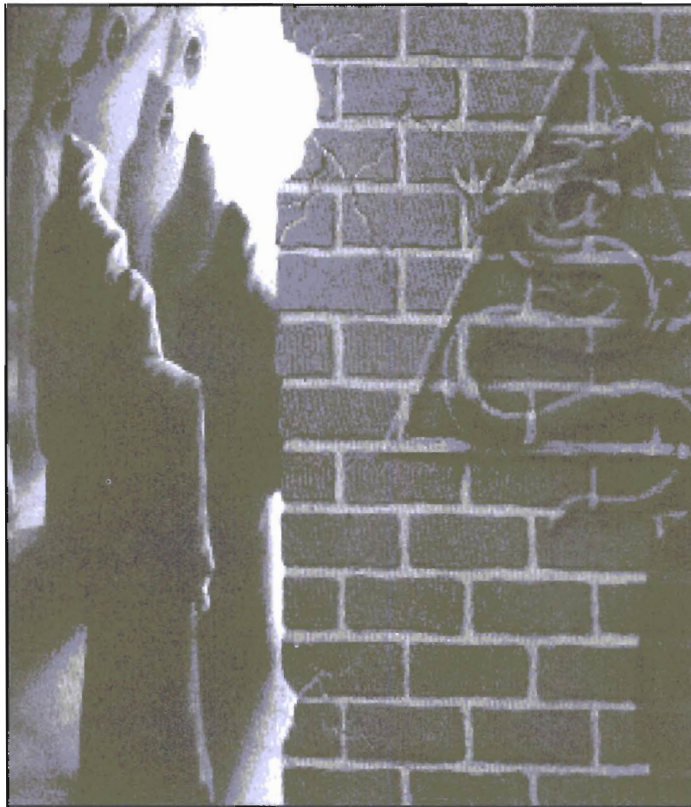

SCENARIO

The place is Los Angeles, California. The year is 2053. And you, a penniless P.I. named William “Blade” Hunter, take your place in this trilogy of turmoil, mystery, and future decay. *Rise of the Dragon*, created by Jeff Tunnell of Dynamix (part of the Sierra family), is a futuristic tale casting only adult characters. Dedicated to verism, Dynamix chose to

have its characters speak like adults. Therefore, the game contains some language that may be unsuitable for sensitive players. Using *real time*, *Rise of the Dragon* strives to achieve virtual reality. Real time requires you to stay on your toes during the entire quest, since the game will continue with or without your presence. Though the storyline is powerful, the graphics aren't all that great. Many screens are small, some not much bigger than a baseball card, and the colors seem vague, even a bit illusive. If you're a diehard adventurer, however, these shortcomings are easily overlooked. But enough chit-chat—it's time for you to hit the streets and use your violent techniques and brash disregard for regulations to put an end to the Dragon.



Jeff Tunnell

WALK-THROUGH

BLADE'S APARTMENT

Begin the quest by checking inventory. To initiate the main inventory window, click the right mouse button on the inventory icon. Since the game's just begun, inventory, naturally, is empty. Pick up the clothes and place them in inventory. Find the coat (it's hanging on the hook to the left of the window) and place it in inventory. Once you have these items, you'll need to dress Blade. To accomplish this, right-click on the inventory icon to bring up the main inventory window. Hold down the left mouse button and drag the clothes over Blade. Release the button and Blade will be wearing them. Repeat this procedure with the coat.

Examine Blade's apartment. Find the cupboard above the sink. Click on it to get a closer view. To exit the cupboard scene, move the cursor outside the picture window and click the right mouse button. Left-click on the pillow and you'll find Blade's weapon. Put the pistol in inventory and replace the pillow. The power cartridge for the gun sits next to the VidPhone terminal. And, speaking of the VidPhone, click on it for a closer view. The flashing red light alerts you to any recorded messages. Turn on the power by clicking on the main power switch. To operate the VidPhone, use the remote control. Play all three messages and pay close attention to the first and last message.

The first message is from Vincenzi: His daughter was brutally murdered and she was last seen at the Pleasure Dome with someone named The Jake. You'll also receive a hardcopy (picture) of his daughter. Take the hardcopy. The third message is from Karyn, your girlfriend. She's irate because you (a.k.a. Mr. Romance) stood her up last night. And, to make the situation worse, she has your keys. You'll need to meet with her at the Bureau of Records later in the day. Before turning off the VidPhone, get your I.D. card from the slot. If you forget to take it and leave the apartment, you'll be locked out. Finally, take the power cartridge (used to charge your weapon) near the lower-left corner of the screen. Enter the bathroom and open the medicine cabinet. Get the bottle of NaPent and the first-aid kit. Left-click on the inventory icon to bring up the quick-inventory window.



RISE OF THE DRAGON

Right-click on the NaPent to get a description of this item. You can, and should, do this with every item you place in inventory.

To review: Karyn's infuriated with you, she has your keys, and she'll be at the Bureau of Records; Vincenzi's daughter was brutally murdered and she was last seen at the Pleasure Dome with someone named The Jake.

It's time to get your keys and find this Jake guy. To leave the apartment, move the cursor to the left side of the screen and click the left mouse button. When you're in the hallway, click on the lower elevator button to enter the Em-Way.

CITY HALL

Locate the Em-Way map and travel to City Hall. Talk to the flower vendor and buy a dozen roses using response No. 2. Pay for the flowers with your I.D. card and remember to place both your I.D. card and the flowers in inventory.

Walk past the bum and you'll see the entrance to City Hall. Enter the lobby and talk to Jenni. Deny all her proposals. If you accept any of them, Karyn may break up with you, ending the game. Use the following responses when talking to Jenni:

❑ 2-1

Enter the Bureau of Records and speak to Karyn using the following dialogue responses:

❑ 3-3

Get the keys. Travel to Blade's apartment. Enter the apartment using the I.D. card in the security lock. After the door opens, remove the I.D. card from the slot. Use the keys to open the locked cupboard. Get the mini-bombs, the wire-tester kit, and the Fisto candy bar.

This would be an opportune time to charge your weapon. Click on the inventory icon and drag the power cartridge over the gun. Once the power cartridge vanishes from the inventory window, you have properly loaded the gun. Travel to the Pleasure Dome. The bouncers will scan your body and detect the weapon. Use the second response when conversing with Slen. Give your gun to Martha, the woman in the window. When Slen asks if you have anything else,

give him the candy bar. In return, he'll give you a claim ticket for your weapon. If you don't give Slen the candy bar, say goodbye to your gun.

THE PLEASURE DOME

Enter the barroom. The Jake will be sitting at the far end of the bar. Talk to him using the following responses:

1-2-2-1

Show him the hardcopy of Chandra. If you don't have it, go back to Blade's apartment and get it. When you're sitting at the table with The Jake, talk to him using the following responses:

2-3-1-3

After he gives you Chen's address, exit the Pleasure Dome. Give Martha the claim ticket and retrieve your weapon. Go back to the Em-Way station and travel to Chen Lu's place.

CHEN LU'S PLACE

Get Chen's I.D. card from the VidPhone, then leave before the cops get there. When you're at the Em-Way station, travel back to Chen Lu's place. Use his I.D. card in the VidPhone and write down his gun permit number and his S.S. number. In the game version I played, the information was as follows:

SS 2343-343-0772

GP GN102A0772

Enter the bathroom. Get the drug patch from the counter. Enter Chen's bedroom. Click on the dragon's eye and the statue will lower into the base, revealing a wall safe. To open the safe, find the four digits common in both Chen's gun permit number and the S.S. number:

0772

Get the candy bar and the oriental script. Leave Chen Lu's apartment and head

RISE OF THE DRAGON

back to the Em-Way.

THE WAREHOUSE DISTRICT

Travel to City Hall. When you see the flower shop, click the cursor to the right of the flower peddler. There you'll find the alleyway leading to the warehouse district. Follow the alleyway until you reach an old oriental man sitting on an empty shipping crate. Talk to Chang Li using the following responses:

2-1

Give him the scroll (which you found in Chen's wall safe) and he'll be happy to translate it for you. Next, he'll give you four items:

- Bulletproof vest
- Tome of Ancient Wisdom
- Rock of Life
- Fortune cookie

It's time to meet Karyn for your date. Travel to Karyn's house and enjoy the evening. Next morning check the VidPhone for messages. If there aren't any, travel to City Hall. Enter the Bureau of Records. Talk to Karyn. Give her the drug patch and she'll have it analyzed. Give Karyn Chen's I.D. card. When the computer screen appears, find the box labeled *SELECT* and click on

- No. 1
- No. 2

Before leaving the Bureau of Records, grab Chen's I.D. card and place it in inventory. Now travel to Jonny Qwong's house.

JONNY QWONG'S HOUSE

You can't get into Jonny's house, but you can get under it by clicking on the manhole cover. Once you're in the sewer, save the game. Because you're on a time limit, the following sequence is very difficult to complete. If you act too slowly, the sewer rats will eat you. After saving the game, find the VidPhone

trunk. Look at the schematic wiring diagram (like that's really going to help). Blow open the access panel with a mini-bomb. Get the wire tester from inventory and click it on the panel. Again, save the game. Only after you see the close-up view of a sewer rat can you begin the difficult operation of tapping Jonny's VidPhone. Take a deep breath and prepare to restore the game often. Follow these steps carefully:

- Place the red alligator clip on the left (red) wire attached to the battery located just to the right of the meters.
- Affix the blue alligator clip to the yellow ground clip attached to the conduit near the bottom of the panel.
- Finally, locate the eight vertical (yellow) terminals and affix the yellow clip to the second terminal from the bottom.

After succeeding, I must congratulate you! That was the most difficult sequence in the entire game. Now travel to the Pleasure Dome. Enter the barroom. Talk to The Jake. He'll suggest that you sit at his booth. Give Jake the chocolate bar (DO NOT give it to Slen). Use the following response with The Jake:

- 2-2-1-1

Leave the Pleasure Dome. Travel to Blade's apartment. Check the VidPhone for messages.

THE WAREHOUSE

It's time to flex your muscles and show these guys who they're really up against. Remember those handy-dandy mini-bombs you took from the cabinet? Well, let's use one to blow up the warehouse. Travel to City Hall. From the scene with the flower peddler, walk down the alleyway. When you see a large fan (and a small door in the distance) move the cursor over the fence near the right side of the screen. When the cursor changes into

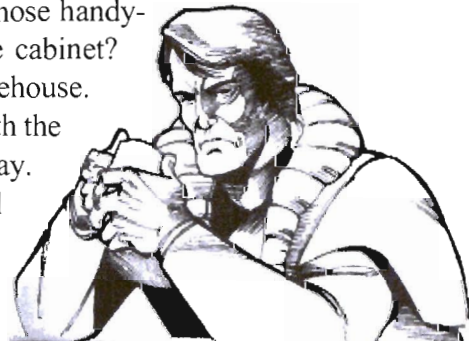

RISE OF THE DRAGON

an *EXIT* sign, click the left mouse button.

Welcome to the warehouse. Find the door at the far end of the room. Look through the window. Exit the scene. Find the reactor electrical system. Place a mini-bomb on the second electrical panel and run for cover.

Hey, I'll bet The Jake would like to hear about your dastardly deed. Travel to the Pleasure Dome. Check-in your gun with Martha (don't forget to take the claim check). While conversing with The Jake, do as he asks. And if the day hasn't ended by now, you're one hell of an adventurer!

THE LAB RESULTS

Begin the new day by traveling to City Hall. Enter the Bureau of Records. Speak to Karyn using the following responses:

2-2-2

Before leaving the Bureau of Records, take the MTZ VCR tape. Now you can visit the Mayor and show him some hard evidence. Talk to Jenni and tell her that you must see the Mayor. Use the following responses:

1-1

Use the following responses when conversing with the Mayor:

3-2-2

He'll agree to your demand and give you a security pass. With this pass, you can gain access to the police armory—the perfect place to get a bigger gun. Before leaving his office, take the pass and place it in inventory.

POLICE HEADQUARTERS

After the Mayor has given you the security pass, enter Police Headquarters and show the guard your pass. Locate the armory. Do you see what I see? Grab the M1000X assault rifle from the wall mounts and tuck it safely in inventory. You may look around if you wish, but the rifle is all you'll need from the armory. Explore the city until the day ends, or speed up the game time using the inventory

window.

Start the new day by checking the VidPhone for messages. To your horror, you learn that Deng Hwang has kidnaped Karyn—and if you interfere with his plans, he'll kill her. Maybe he's bluffing. To find out, travel to Karyn's apartment. If you find her, you can relax. If she isn't there, try her place of employment—the Bureau of Records. If you still can't find her, go back to Blade's apartment, remove your coat, and put on the bulletproof vest. Place the coat over the vest and continue your search for Karyn.

AUGUST 4, 2053

Begin the new day by checking the VidPhone for messages. You should have a message from The Jake: He wants to meet with you at 8:30 p.m. at the warehouse. Since it's still early in the day, you can continue your search for Karyn.

When the clock strikes 8:30 p.m., prepare for the first arcade sequence of the game. If you don't like arcade, try it five times and the game will allow you to bypass it. After the arcade sequence, get Snake's I.D. card and place it in inventory. Now travel to the Hollywood Reservoir.

THE RESERVOIR

Prepare for battle by saving the game. If you have the assault rifle, definitely use it. If you only have the pistol, don't despair—you can still win this arcade sequence. Wearing the bulletproof vest enables you to take a few hits, but don't take too many or you'll die. If you're using a mouse, move the crosshairs over the soldier that you wish to shoot, then strike the space bar. This is probably the easiest way to defeat them. Slowing down the computer is another way.

After killing all the soldiers, steal their hovercar. To operate it, look at the map in the center of the dashboard. Click on Deng Hwang's place and you'll travel there automatically.

DENG HWANG ENTERPRISES

After landing on the roof of Deng Hwang Enterprises, exit the hovercar. Enter the red elevator. Use the following responses with the receptionist:

3-1-1-3

Save the game. Enter the security room by walking west. Find the security panel located under the big-screen display. Once you have a close-up view of the panel, you must act very quickly, because the guards are hot on your trail.

Hint: Perform the following procedure rapidly.

Flip the large, blue lever (at the lower-right corner of the panel). The screen must display the following sentence(s) before you can enter the manual override code:

INSERT ID CARD

or

ENTER MANUAL OVERRIDE

Click on the inventory icon and look at the fortune cookie the oriental man gave you. There you'll find the security code. The code is—

RYP YWP YRP WRY PBW

After bypassing the security code, slide the four switches to the following positions:

HOLDING LOCK — UNLOCK

ROOF LOCK — UNLOCK

BREAK LOCK — LOCK

JANITOR LOCK — UNLOCK

Locate the small, square button at the center of the console. Turn off the *100 KV* unit. Leave the security room. Exit the lobby by walking to the right of the receptionist's desk (to the left of the elevator). Enter the first red door you come to; this is the Janitor's closet. Open the electrical panels and turn off the circuit breaker. Using the screwdriver (which you took from the sink), open the fuse box panel. Grab a handful of wires and place them in inventory. Exit the Janitor's

closet. Enter the Interrogation Chamber. To save Karyn, begin by clicking the wires on her. Get a close-up view, then disconnect the three wires attached to the Arterial Injection Collar (do this before time runs out on the clock located behind Karyn). One final arcade sequence to go and you're home free. If you don't like arcade, try it five times and the game will ask if you wish to skip it. Answer in the affirmative and enjoy the climax of the story.

LOCATION OF OBJECTS

- Bulletproof Vest Chang Li
- Chen's I.D. Card Chen Lu's VidPhone
- Clothes Blade's Apartment
- Coat Blade's Apartment
- Cupboard Keys Karyn (Bureau of Records)
- Drug Patch Chen Lu's Bathroom
- First-Aid Kit Blade's Medicine Cabinet
- Fisto Candy Bar Cupboard/Chen Lu's Safe
- Flowers Flower Peddler
- Fortune Cookie Chang Li
- Hardcopy Blade's VidPhone
- I.D. Card Blade's VidPhone
- M1000X Assault Rifle Police Armory
- Mini-Bombs Blade's Cupboard
- MTZ VCR Tape Karyn (Bureau of Records)
- NaPent Blade's Medicine Cabinet
- Oriental Script Chen Lu's Safe
- Power Cartridge Blade's Apartment
- Rock of Life Chang Li
- Screwdriver Sink (Janitor's Closet)
- Security Pass Mayor
- Tome of Ancient Wisdom Chang Li
- Weapon Under Pillow (Blade's Apartment)
- Wire Tester Cupboard (Blade's Apartment)
- Wires Electrical Panel (Janitor Closet)

MAPS

BLADE'S APARTMENT

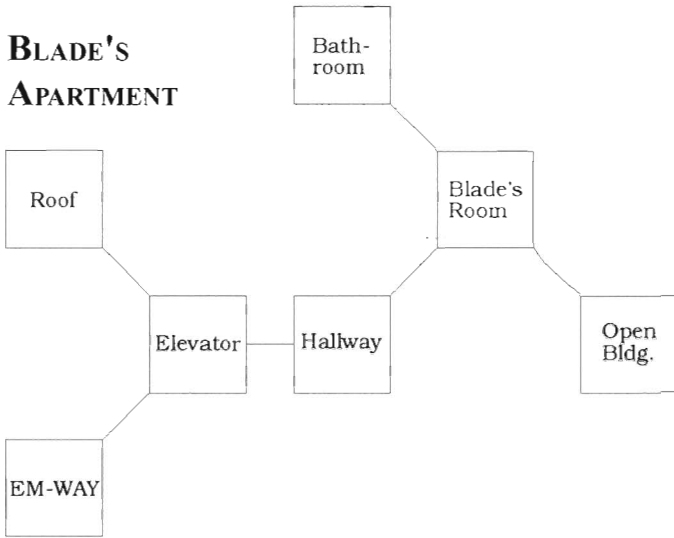

PLEASURE DOME

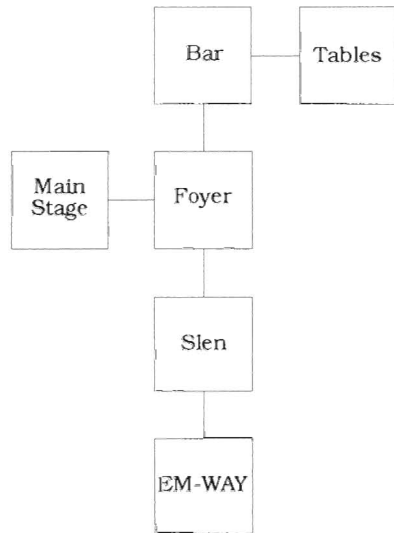

CITY HALL

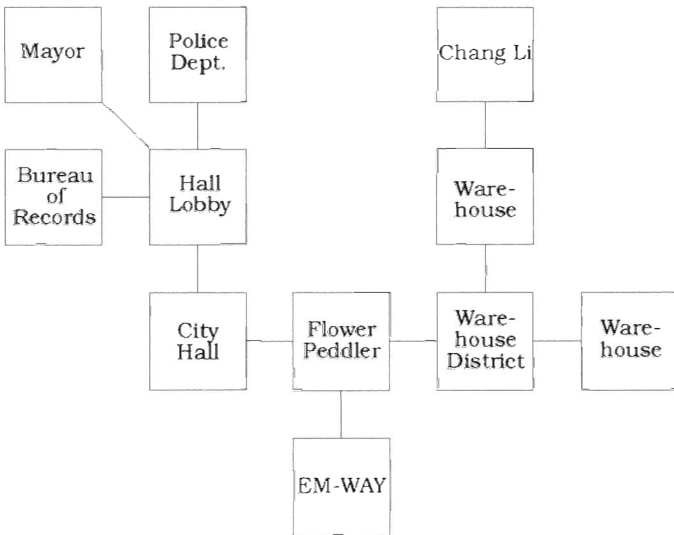

CHAPTER 4

HEART OF CHINA

GRAPHICS:	☆☆☆☆	STORY LINE:	☆☆☆
ARCADE:	☆☆	INTERFACE:	☆☆☆☆
DIALOGUE:	☆☆	AUDIO:	☆☆☆
ANIMATION:	☆☆☆	LENGTH:	☆☆☆

OVERALL ANALYSIS: ☆☆☆

SYSTEMS

- MS-DOS IBM-PC/Tandy & Compatibles
- Amiga
- Macintosh

FEATURES

- Breathtaking graphics and an original stereo soundtrack bring the adventure to life.*
- A rich, detailed story unfolds through characters that think for themselves, remember your actions, and challenge your every move.*
- A powerful yet easy to use point-and-click interface allows you to explore, communicate, and interact without typing.*



SCENARIO

Heart of China by Dynamix instantly grasps your attention with a *Raiders of the Lost Ark* or *Romancing the Stone* atmosphere. You'll travel the cluttered streets of Hong Kong, cross knee-deep snowfields in the Himalayas, and take a breathtaking ride on the Orient Express. Along your journey you'll encounter many worthy companions that you may want to travel with. Once they've accepted you into their group, you'll know what they know. What they can do, you can do. Simply placing a certain character in control can aid in your gaming strategy. The characters in

Heart of China, like yourself, have a past that shouldn't be overlooked. They also remember what you've said and/or done to them—so treat everyone with a subtle kindness while remaining extremely cautious. In addition, a clever device called a Romance Meter has been incorporated into the game. This meter registers Kate's feelings toward Lucky. You can access the Romance Meter any time while in flight. And it's imperative that you do so: You could solve all the puzzles in the game but not see the optimal ending sequence if Kate and Lucky aren't on friendly terms come Paris.

WALK-THROUGH

THE DOCK OF HONG KONG HARBOR

Move the arrow cursor over the debris in the water. Click the right mouse button to look at it (follow this procedure every time you want to look at an object). Now shift your attention to the seagull. Look at it, then move the cursor over the inventory icon. Click the right mouse button. Left-click on the gun and drag it over Lucky. Release the mouse button and Lucky will be ready for action. Click on *EXIT* to leave the inventory window.

Let's see if you're a sharpshooter. Press and hold the right mouse button until you see the crosshairs. Move the crosshairs over the seagull and (while holding the right mouse button) click the left button to fire. Bye-bye, birdie. If you missed, try again.

THE RICKSHAW COOLIE

The rickshaw coolie is the taxi you'll use to travel around town. There's no air conditioning, radio, or rumble seat, but it sure beats walking.

THE TOWN OF HONG KONG

Have the coolie take you to Hong Kong. Look at everything. Notice the exit signs and where they lead. There are two doors to your right: One leads to Madam Wu's place, the other to Ho's bar. Enter Ho's bar. Oh, I almost forgot—in Hong Kong, they don't appreciate people walking into their establishments waving a gun around. So if you haven't pocketed the gun, do so now.

Reenter Ho's bar. Carefully look around while remaining as discreet as possible. Move the cursor to the left side of the screen. When the cursor changes into an exit sign, click the left mouse button. The screen will scroll toward the bar. There you'll encounter Ho and a dangerous lady of the evening. Use the following responses when communicating with Ho and the Goon:

- Conversation with Ho: 3-1-1-1
- Conversation with Goon: 1-2-1-3-2

By now you know that the Goon is really Chi. Unfortunately, Chi refuses to fly in an airplane. Therefore you must convince Chi that “arrow-planes” really can fly. To do this, leave the bar and retrieve a leaflet blowing about the streets of Hong Kong. Reenter the bar and (by using the main inventory) drag the leaflet to Lucky’s hand. He’ll automatically fold it into a paper airplane. Exit the inventory window while holding down the right mouse button. To toss the plane, click the left mouse button.

After leaving the bar with Chi, you should familiarize yourself with switching characters. Click on Chi’s icon. Check Chi’s inventory. Exit the inventory screen and return control to Lucky.

Chi will want to visit Madam Wu’s place to obtain healing herbs. Since she doesn’t want to communicate with Lucky, place Chi in control. After Chi convinces her to speak to Lucky, return control to Lucky and continue with the conversation. Madam Wu will have an unusual request—bring her some disgusting seagull doo-doo. Using the coolie, travel back to the docks and change control to Chi. From Chi’s inventory, grab the prune and give it to the seagull. Get the doo-doo that Madam Wu requires.

Travel to Wu’s place and give her the seagull droppings. In return she’ll give you the healing herbs, then offer you other things that may or may not help you with your quest. I suggest taking the map. Now it’s time to visit Lomax. Use the coolie to travel to Lomax’s place. But be forewarned: He won’t be thrilled to see you.

THE AIRPORT

After your (ahem) friendly encounter with Lomax, it’s time to leave Hong Kong via the *Yankee Eagle* and fly to Chengdu. Use the coolie to travel to the airport.

Who’s that man standing in front of the *Yankee Eagle*? Why, it’s an Immigration Official (gulp). Whatever you do, don’t give him the fake passport—if you do, you’ll spend the next 10 years behind bars. When a response is required, choose No. 2. Board the plane and examine the entire aircraft. Find and take the crowbar, grappling hook, and rope. Have you noticed that the cursor changes into an airplane when you move it across the cockpit area? Click the mouse button when the airplane cursor appears—it’s time to pilot the *Yankee Eagle* to Chengdu. When you’re deep within the clouds, click the left mouse button to exit this screen. Ask Chi where to land the plane.

Hint: Ask Chi where to land the plane.

CHENGDU FORTRESS

It's time for Chi to earn his money. Before placing Chi in control, give him the rope, grappling hook, and healing herbs. Give control to Chi and have him talk to the peasant. Use the following responses:

☐ 1-1-1

Have Chi wear the peasant's clothing. Get the cow (using the rope) and travel to the fortress. Hide behind the bushes until you witness another peasant approach and enter the gate. Observe him carefully.

Hint: Plot Branch.

With Chi in control, enter through the front gate. Once inside, change into the Ninja Veil. Visit the gate house and grab the keys hanging next to the window. Also, with Chi in control, enter the Throne Room—there you'll gain important information.

Travel to the fortress's west wall. Using the inventory icon, combine the rope with the grappling hook and toss it over the wall: This will allow Lucky to enter the fortress grounds. To rescue Kate, begin by placing Lucky in control. Hide inside the gate house until the guards have passed. Enter the Dining Room (located west of the Throne Room). Find the bottle of rice wine and place it in inventory. Now you must create a diversion to preoccupy the guards. Knocking over the oil lamp will create a fire in the Dining Room—a perfect diversion. Knock over the lamp and dash into the kitchen. Oops, did I forget to mention that there's a mean ol' dog in the kitchen? Don't despair, just pour the rice wine into his bowl. Enter the cook's bedroom. Grab the knife on the night stand. Enter the Great Hall by walking through the far doorway. There you'll find Kate guarded by a pair of cobras. To give yourself more time, bar the door behind you. Shoot

one cobra. Unfortunately, Kate will be bitten by the remaining snake (this is unavoidable). Grab Kate and run to the balcony at the far end of the Great Hall. Climb down the balcony by clicking the left curtain rope on the center of the railing. Slide down the rope to escape the guards.

THE TANK

Arcade, arcade, arcade—it's here to stay. And now it's time to test your skills. You may skip this arcade sequence by answering the game's query as such. Or you can adjust the difficulty level of the arcade sequence. But you should at least try it once—it's really exciting.

To start the tank, place the key in the ignition and turn it. Press the button directly above the ignition to start the engine. To make the tank go forward, use the up-arrow key. To slow the tank, use the down-arrow key. Use the left and right arrow keys to maneuver the tank and the space bar to fire. Follow the road while blasting any tanks that appear in your path. When you reach the T in the road, turn left. Proceed at top speed, but watch for obstacles such as cows. After the herd has passed, you'll have a tank hot on your trail. Quickly turn and fire. Continue on until the road ends. Turn left. Enter the *Yankee Eagle*.

KATHMANDU

Before reaching Kathmandu, check the Romance Meter by clicking on the heart icon. Then click anywhere on the map to land at Kathmandu. After crash-landing on the icy plains of Kathmandu, exit the plane. Discuss a plan with Chi. Use the following responses:

- ❑ 2-1-3

Hint: Plot branch.

After Lucky goes for help, enter the *Yankee Eagle* and grab the blanket and tarp: These two items must be used to shelter Kate. Use the healing herbs on Kate. Have Chi perform his Shaolin healing ways. Do this by pressing and holding the right mouse button until the cursor changes into a hand. Place the hand cursor

HEART OF CHINA

over Kate's forehead and click the left mouse button.

AMA'S HUT

Welcome to Ama's hut. With Lucky in control, talk to Ama using the following responses:

3-1-1-1

Kate will be too weak to speak with you. If you return later, however, she'll be well enough to converse. Say goodbye to Ama and exit her hut.

THE LAMA SANCTUARY

The Lama's Sanctuary is located on the crest of the center mountain. Once you reach it, click on the door. You'll be greeted by a disciple. Use response No. 3. Look at the items in the room, then speak to Wally Lama using the following responses:

1-1

When the Lama begins to pray, leave the Sanctuary and travel to town.

THE TAVERN

Okay, you've visited Ama and Wally Lama. Now, it's time to visit Sardar in the tavern located on the left side of the screen. Enter the tavern and find Sardar. Talk to him. If he seems a bit reluctant, buy him a drink—heck, why not buy everyone a drink? Do this by talking to the bartender. Once Sardar has a few drinks in him, he'll talk to you again. Use the following responses with Sardar:

2-2

Leave the tavern and check on Kate: By now she should be well enough to talk to you. After using the following responses, travel to the junkyard:

3-3

THE KATHMANDU JUNKYARD

Welcome to the Kathmandu Junkyard, a favorite hangout of young Kubla's. Kubla is the only one in town who can help you get petrol for the *Yankee Eagle*. Unfortunately, Kubla is aware of the fact that his precious cargo is worth a lot to you. So you must convince Kubla to give you the petroleum.

Begin by switching characters. With Chi in control, find and take the cigar box. Left-click on the inventory icon. With the items in Chi's inventory (except the herb), make a pull-toy for Kubla. Combine the following items:

- Coins
- Chopsticks
- Cigar box

Change control to Lucky. Talk to Kubla using response No. 1. Give Kubla the pull-toy and he'll give you a siphon hose. Place this hose in inventory and leave the junkyard.

TELEGRAPH OFFICE

Before heading back to see Wally Lama, visit the telegraph office. There you'll need to send a telegram to Lomax. This sequence is self-explanatory.

BEFORE LEAVING TOWN

After sending the telegram, have Chi talk with the teller. Leave the telegraph office and travel to the Lama Sanctuary. The Lama will gladly speak to you. Listen closely to what he says. Before leaving Kathmandu, you must revisit the tavern and speak to Sardar using the following responses:

- 1-2-1

I know this sounds crazy, but get your gun from inventory and give it to Sardar. This will give him and the rest of the townspeople enough power to attack Bojon. While in flight, check the Romance Meter. I'll see you in Istanbul.

HEART OF CHINA

ISTANBUL

Welcome to Istanbul. If you haven't already done so, exit the *Yankee Eagle*. You'll notice Turk, the mechanic, standing at the right side of the screen. Talk to him; he'll give you your next clue. Leave the airport. Enter the gates of the city.

Hint: *The following sequence must be performed rapidly.*

Enter the city and immediately go to the side street. Enter the British Officers' Club; Kate will remain outside. Speak to the bartender, Hoji. Have two drinks, then ask to use the telephone. Use the following responses with Hoji:

1-1-2

Once you have E.A. Lomax on the line, use the following responses:

1-1

Talk to Hoji. Leave the British Officers' Club and you'll be captured. Don't be alarmed; the game will continue, but with Kate in control. As Kate, you must figure out a way to rescue Lucky. Begin by visiting the Pawn Shop.

THE PAWN SHOP

Talk to Kasim, the owner. Find the hacksaw. Left-click on Kate's inventory icon and give Kasim the locket. Use the following dialogue responses:

3-2-1

Accept no less than 105 sheckels for the locket. Purchase the hacksaw. Before leaving the Pawn Shop, be sure to place the hacksaw in inventory. Now it's time to play Mohmar's shell game.

THE SHELL GAME

Before playing the shell game, save the game (Mohmar tends to cheat when he's losing). You'll find Mohmar sitting on the street corner. Try talking to him and he'll beckon to you. Accept his invitation.

Place your bet by clicking on the up-arrow icon. To lower the bet, click on the down-arrow icon. Once satisfied with the bet, click on the *PLACE BET* icon. Watch the shell closely: Mohmar is very quick (and sneaky). Play the shell game until you win at least 200 sheckels.

THE CAMEL, THE FLOWER, AND ALMIRA

It's time to buy a camel, find a flower, and get help from Almira. First, buy a camel. Do this by traveling to the city gates; there you'll find the camel trader named Acayib. Talk to him using the following responses:

❑ 2-2

Pay no more than 100 sheckels for the camel. Also, remember to place the camel within Kate's inventory—otherwise, it'll stroll away. Now, you need to obtain a flower for Almira. Across from the camel trader you'll see a young boy named Hakim. To get his attention, tip over his cart. Use response No. 1. Once you have the flower, you must obtain Almira's help. You can find Almira at Nabob's Palace. Speak to the guard. Walk to the west side of the palace. Talk to Almira. Give her the flower that you received from Hakim, and she'll help you rescue Lucky.

Once Lucky has been freed, travel to the airport. After the *Yankee Eagle* explodes, hustle to the train station. Purchase a cabin ticket from the agent at the ticket booth. Place the ticket in the inventory before boarding the train. Don't think that you're safe on the Orient Express—there's someone following you ...

LOCATION OF OBJECTS

- Blanket *Yankee Eagle*
- Cabin Ticket Ticket Booth
- Camel Camel Trader (Acayib)
- Cigar Box Junkyard
- Cow Peasant
- Crowbar *Yankee Eagle*
- Disguise Peasant
- Fake Passport Madam Wu
- Flower Hakim
- Grappling Hook *Yankee Eagle*
- Hacksaw Pawn Shop
- Healing Herbs Madam Wu
- Keys (Tank) Gate House
- Knife Cook's Bedroom
- Leaflet Streets of Hong Kong
- Map Madam Wu
- Rice Wine Dining Room Table
- Rope *Yankee Eagle*
- Seagull Droppings Docks
- Siphon Hose Junkyard (Kubla)
- Tarp *Yankee Eagle*

MAPS

HONG KONG

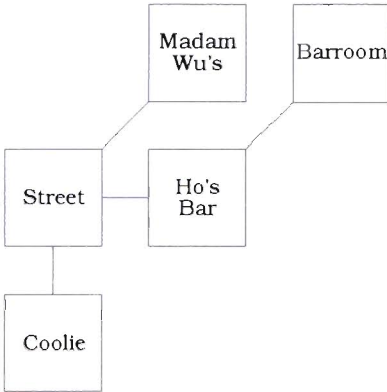

CHENGDU FORTRESS

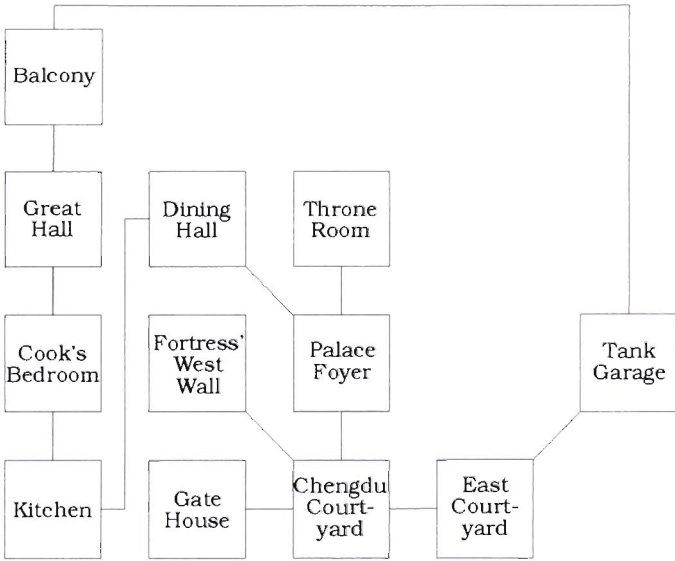

KATHMANDU

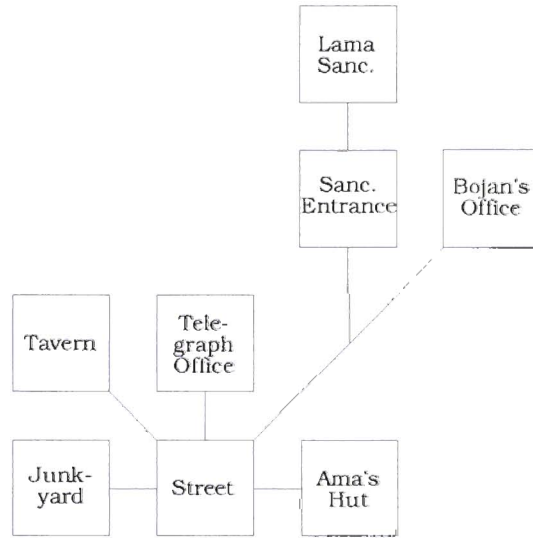

ISTANBUL

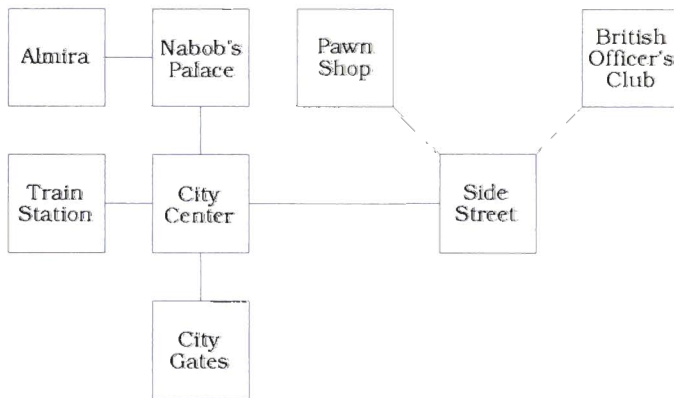

CHAPTER 5

LEATHER GODDESSES OF PHOBOS 2

GRAPHICS: ☆☆

STORY LINE: ☆☆

ARCADE: N/A

INTERFACE: ☆☆☆☆

DIALOGUE: ☆☆

AUDIO: ☆☆

ANIMATION: ☆

LENGTH: ☆☆

OVERALL ANALYSIS: ☆☆

SYSTEMS

- MS-DOS IBM-PC/Tandy & Compatibles

FEATURES

- Marvel at the astounding attractiveness of shapely attendants lusciously illustrated in high-resolution graphics.*
- Listen to conversations and clues broadcast over your LifeSize Sound Enhancer to more than an hour of amazing digital soundtrack.*
- Scream at the pig-headed residents of Atom City who get fooled by the Goddesses' conniving plot—they think you and Barthgub are the enemy.*
- Set them straight with the reclusive scientist and his beautiful daughter—they know the real story.*
- Writhe in the clutches of the Amazonian Leather Goddesses when you travel to their evil Pleasure Palace to rescue the love slaves from unspeakable torture.*
- Save the human race when you sabotage the scheme to conquer Earth.*



SCENARIO

Designed and written by Steve Meretzky for Infocom, *Leather Goddesses of Phobos 2* is actually three games in one: Which character you select determines the game version you'll play. The character choices are: Zeke Zarmen, owner of a gas station; Lydia Sandler, the beautiful daughter of Professor Sandler; or Barthgub el Nikki-

Nikki, son of Jelgobar el Zayda-Zayda. Barth, by the way, is an alien from Planet X. And yes, you guessed it: This is a science-fiction, adult-oriented adventure. The story takes place in the peaceful town of Atom City. The year is 1956 and Planet X is believed by Earth scientists to be the tenth planet in the Solar System (remember, this is the 1950s). Unbeknownst to the townspeople, a lone spacecraft was careening across the galaxy when it struck a small meteor that knocked it off course. Barth tried frantically to steer his crippled spacecraft away from Earth, but his gallant efforts failed and he crashed somewhere near their dusty Nevada town. Your mission, as Zeke or Lydia, is to find the alien, heal him, and save Earth from the clutches of the Amazonian Leather Goddesses. Your mission, as Barth, is to find some food, heal your wounds, and repair your spacecraft. To enhance gaming enjoyment, *LGOP2* uses digitized speech. If you *don't* have a soundboard installed in your system, you're still in luck. Included with this game is a device called the LifeSize Sound Enhancer. When plugged into an unoccupied printer port, the Enhancer simulates the sounds produced by a soundboard. It does, however, require amplification.



Steve Meretzky

WALK-THROUGH

ZEKE ZARMEN

Click the mouse button to bring up the character-selection screen. Move the cursor over Lydia and she'll introduce herself. The same goes for Zeke and Barth. Let's play the game as Zeke Zarmen. Begin by talking to Lydia. She'll ask you to investigate the meteor—this is your first clue. Also, she'll ask you to meet her in the Diner later that evening, so don't forget. Study the menu of icons. These icons contain pictures of the people and/or items you can ask about. The bottom icon (the lips) is for kissing. Begin with the top icon and work your way down the icon menu.

THE METEOR

To find the meteor (spacecraft) Lydia mentioned, travel west, then north. Note the muddy tire tracks leading to a dirt road. Follow the dirt road until you see the tail of the spacecraft. Turn west to view the entire ship. Open the spacecraft's door and climb inside. Jingle the dice and try the levers. By turning 180 degrees, you can view the rear of the cockpit. Jingle the dice again, then exit the ship.

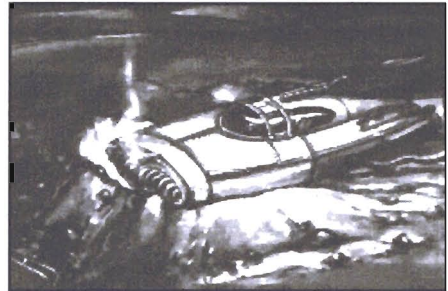

Travel east, then north. Welcome to Coyote Gulch. Look at the boat. Travel back to the main highway. Walk south, then north until the road ends at Tunnel 73. Walk back to the gas station.

THE GAS STATION

Talk to Slow Flo. Click on the remaining icons to get as much information from her as possible. When you're finished with Flo, investigate the bathrooms. Enter the gas station's office. Talk to Stern Doe. Search the room. Take the staple remover from the desk. Before leaving the office, look at the calendar. Zoe, your mechanic, is busy fixing the General's car in the garage. Once you're face-to-face with Zoe, grab the frobizmus hose from the vehicle's fender. Greet Zoe.

LEATHER GODDESSES OF PHOBOS 2

Work your way down the icon menu. If you give Zoe a kiss, she'll give you a wonderful surprise. Open the passenger door of the General's car. Get the transmitter. Click on the horn. Turn the ignition key. Travel to Atom City.

THE SHERIFF'S BUILDING

Welcome to Atom City. Enter the Sheriff's Building (the gray two-story building with six pillars). Look at the map on the back wall. Use the staple remover (which you took from the desk at the Service Station) to remove the map. With the map in inventory, you can refer to it any time during game play. Check the cell to your left. Exit the Sheriff's Building. Travel to KARC radio station.

KARC

Inside the radio station you'll see a record collection, a microphone, a turntable, and many other gadgets found in a typical broadcast studio. So what are you waiting for? Spin some records. If you've placed a record on the turntable but you can't hear it, flip the red lever to activate the transmitter. Once you're familiar with the console, exit KARC and travel to Dealer Dan's.

DEALER DAN

Every town seems to have a used car dealership, and Atom City is no exception. After conversing with Dan, leave the outdoor showroom and head elsewhere. (Unless, of course, you want to buy a lemon.)

CIVIL DEFENSE AID STATION

Dr. Skelton's office is located just east of the Sheriff's Building. Here you can get some very useful chemicals. Enter the office and search the entire room. In the cabinet you'll find the following chemicals:

- Iodine
- Rubbing alcohol
- Sulfur

Take the sulfur (you may take the rubbing alcohol and the iodine if you wish, but these items may only confuse you later in the game). Exit the Aid Station.

THE RIVIERA THEATER

Welcome to the Riviera Theater. From the lobby, walk through the left doorway. Get the 3-D glasses. Watch the movie. Exit the Riviera Theater and travel to the First Fundamentalist Fusion Church.

FIRST FUNDAMENTALIST FUSION CHURCH

After entering the church, search the room. Look at the confessional (flagship). Click the cursor on the flagship door and you'll find Reverend Jonas Layberry. If you have plenty of spare time, talk to the Reverend. Soon, however, you'll realize that the Reverend has—how do you say?—gone around the bend. Time to leave the church and visit the Barber Shop.

THE BARBER SHOP

Talk to Tony, Sheriff Andy Schuller, and Dr. Skelton. Listen closely to what they have to say. Exit the Barber Shop and travel to the Mesquito Indian Reservation.

MESQUITO INDIAN RESERVATION

Talk with the tribesman. Unfortunately, tonight *no playum Bingo*. Well, while you're here, might as well check out the souvenir tepee. Hey, a cola machine! Press the coin return to retrieve your very own shiny new dime. After searching the entire tepee, find Butch's Bar.

BUTCH'S BAR

Welcome to Butch's Bar, a seemingly lonely place. Hey, is that a Wurlitzer original? Be sure to play your favorite tunes before leaving. Talk to the bartender, Butch "Muscles" Malloy. Ask him about the alien. Click the cursor on the fist icon. Get the bottle from the bar and place it in the toolbox. Walk into the pool hall. Examine the pool table. Exit the tavern and travel to Professor Sandler's house.

PROFESSOR SANDLER'S HOUSE

One block south of the Indian Reservation is the Sandler home (look for the mailbox). Turn into the driveway and approach the house. After entering the kitchen, look at everything. Talk to Lydia's little brother, Jimmy. Listen carefully

LEATHER GODDESSES OF PHOBOS 2

to what he tells you—this kid is smart. He'll give you pertinent clues, such as:

- Isotopes can be obtained at the base.*
- Sulfured liquid rubber can be used to help heal the wounds in a germanium-based lifeform (the alien).*

Enter the basement and tinker with the Professor's crazy inventions. Pay special attention to the radio—you just might hear an alien broadcast. Leave the house and enter the observatory. Talk to the Professor. Gaze through the Acme telescope and look at the following planets:

- Planet X
- Earth
- Phobos
- MAG

MADAM CHAVEZ AND O'MALLEY'S STORE

Madam Chavez's place is located next to the Megaton Motel. Talk to the Madam. Give her a kiss and you'll receive a heavenly surprise. Snatch the golden key from the message slot. Before leaving, click on the Ouija board. If you're bored, enter Dave O'Malley's general store and read a newspaper.

THE MILITARY BASE: VISIT 1

Are you wondering how to get into the base? Well, remember the boat at Coyote Gulch? That's your ticket into the base. Travel to the other end of town and climb into the boat. You'll travel downstream, landing at a secret spot behind the base. Exit the boat and enter the base by climbing beneath the fence. Enter the barracks (right door). Open MaCloud's locker and snatch his uniform. Close the locker. Exit through the far doorway. Enter Head Quarters. Open the desk drawer. Retrieve the golden key. Place it in your toolbox and get the heck out of there. Put on the uniform (by clicking on it) and leave the base through the front gate. Since you now have the General's desk key, travel to his house.

GENERAL CYRUS WEDGEFELLOW'S HOUSE

Welcome to General C. Wedgefellow's house. Read the sign next to the entrance

door—I hope it doesn't apply to you. Enter the home and use the golden key to unlock the desk. Take both letters and place them in your toolbox. Now leave his house as fast as you can. Once outside, click on the toolbox to view the documents. One document is a government letter marked *TOP SECRET*. The other is a letter from a lady of the evening. Pay a visit to the lady who wrote the letter.

Note: *Her name isn't included in this book because of random generation.*

Travel to the cat house and give the lady of the evening the letter. She'll give you a manilla folder. Place the folder in your toolbox, then leave the cat house. Once you're outside, look inside the envelope: It contains a secret password. Using the game documentation, find the password and write down the corresponding code number—you'll need it to complete the game.

THE MILITARY BASE: VISIT 2

Once you have the secret password, you can travel back to the base. Walk through the entrance gate wearing the uniform. Enter the room marked

❑ *RI*

There you'll find the reactor core and controls. Look at all five screens and jot down any codes (or special instructions) you encounter. Exit through the blue doorway. Enter the laboratory. Click on the machine at the back of the room. Enter the 4-digit code you found in the game documentation (be sure to add 64 to this code). After entering the correct code sequence, push the button marked

❑ *OPEN*

Take the radioactive isotope and leave the base.

LEATHER GODDESSES OF PHOBOS 2

THE DINER

Most likely you've already been to the Diner. If so, did you take the bowl? Once you have the bowl in inventory, talk to Lydia, then kiss her. After a short animated sequence, travel to the used car dealership.

THE ALIEN

You'll encounter Barth, the alien, at the used car dealership. Give him some food (radioactive isotope). After Barth is content, it's time to heal his wounds. Click on the toolbox and place the rubber hose in the bowl. Mix in the sulfur and the whiskey. Give the bowl to Barth. Eventually an angry crowd will gather. It would be best to leave the dealership when this happens. When you're a safe distance from the crowd, click on the toolbox and retrieve the transmitter. Enter the 3-digit code (it was on a screen in the reactor room). A siren will sound and the crowd will dissipate. Now you, Barth, and Lydia can travel to the spaceship. Climb into the spacecraft and talk to Barth. Repair the ship, then speak to Barth again. I'll see you on Planet X.

PLANET X

Welcome to Planet X. Find the Spaceport Regency Hotel. Talk to the bellboy. Enter the suite. Click on the television set and a woman will appear. Talk to Largonna-9. Kiss her. After intermission, she'll inform you that you must travel to Planet Phobos. She'll also give you a self-recording record and invisibility shield belt. Explore Planet X further. Travel back to the spacecraft.

PHOBOS

Welcome to Phobos, a very unfriendly planet. Travel to the large building in the distance. Enter the kitchen. Search the room. Leave the kitchen through the north doorway. To find the dungeon, walk through the north doorway. Release both prisoners, then head back to the dining room. Put on your invisibility belt and walk through the west doorway. When you see the Leather Goddesses, click on the toolbox and retrieve the self-recording record. Listen to (and record) their entire conversation. After recording the conversation, travel to the flagships. Climb the ladder of the left flagship. Hide in the broom closet. Wait there until the ship lands on Earth. Exit the ship and run over to the radio station. There you

can play the self-recording record. Congratulations, you've just completed *Leather Goddesses of Phobos 2*. Now play the game again—except this time play the role of Barth.

BARTHGUB EL NIKKI-NIKKI

After the introduction, you'll be looking at your damaged spacecraft. You'll need to find the following eight items to repair the craft:

- Pylon
- Grapes
- 8-ball
- Bottle
- Stop sign
- Bar of soap
- Pumpkin
- Iron

THE PYLON

You can find a pylon at the entrance to Tunnel 73. To get there (from the spacecraft) travel one screen west, one screen north, one screen south, then one screen north. Click on the pylon and place it in your alien inventory sack. Also, examine the fancy gun in inventory—it'll come in handy later in the game. From the entrance to Tunnel 73, walk one screen south, two screens north, and one screen east and you'll arrive at the gas station. Using your tentacles, greet Flo (and the other two employees). Enter the office and take the staple remover from the desk. Leave the office.

A BAR OF SOAP

The bar of soap is located in the jail cell inside the Sheriff's Building. Enter the Sheriff's Building (the gray building with six support pillars) and remove the city map from the far wall using the staple remover. Walk west into the jail cell and say hello to Sheriff Schuller. After he throws you in the slammer, get the bar of soap from the sink. Blast your way out of the jail cell using that fancy gun in inventory.

LEATHER GODDESSES OF PHOBOS 2

THE BOTTLE

Travel to the Indian Reservation. Greet the Indian. Enter the souvenir shop (the tepee) and get the dime from the cola machine. Remove the cover from the trash can. Get the bottle. After placing both these items in inventory, you can leave the Reservation. If you're wondering what the dime is for, it can be used to buy a pumpkin at O'Malley's general store.

THE PUMPKIN

You can purchase a pumpkin at O'Malley's Store—if you have a dime, that is. To get there from the Indian Reservation, walk one screen east, three screens north, and one screen west. Enter the teal-colored building. Greet O'Malley. Give him the dime you found in the tepee. Take the pumpkin and a newspaper. You can read the newspaper by clicking on it from the inventory screen. Leave O'Malley's general store and find a bunch of grapes.

A BUNCH OF GRAPES

You can find a bunch of grapes at the Diner. Once inside, greet the waitress. Then walk one screen south. On the table to your left, you'll find some red (purple) grapes. Click on the grapes and place them in inventory. Leave the Diner and find an 8-ball.

THE 8-BALL

Enter Butch's Bar. Walk into the pool hall (don't forget to play your favorite tunes on the jukebox). Approach the pool table and place the remaining balls into any pocket. Get the 8-ball. Before leaving the bar, talk to Butch.

THE STOP SIGN

Walk around town until you come across a Stop sign. After clicking your tentacles on it, you'll realize that you aren't strong enough to remove it from the post. Blast it with your laser gun. You now should have seven of the eight items necessary to repair the spacecraft. Now let's find the final item: the iron.

THE IRON

The iron is located in Professor Sandler's home. Enter the kitchen. There, on the counter, sits the desperately needed iron. Unfortunately, Jimmy won't let you take it (the little brat). He wants some technology in exchange. Since the gun is fully discharged, give it to Jimmy in exchange for the iron.

THE ANGRY CROWD

Since you're carrying all the items necessary to repair the spacecraft, your first instinct would be to go to the crash site. Before traveling there, however, stop in at Dealer Dan's (if you don't, you'll be sent there later in the game). At Dealer Dan's you'll encounter Zeke and Lydia. Talk to Zeke and he'll have a solution to patch up your wounds. Talk to Lydia and she'll give you some food. Eventually an angry crowd will appear. When a problem with the reactor occurs, vamoose. Travel to the crash site and repair the spacecraft. See *Zeke Zarmen* for additional clues.

LYDIA SANDLER

The game begins in the Sandler home. Talk to Lydia's father, the Professor, then to her younger brother, Jimmy. Ask Jimmy about the alien, the food it eats, and what it requires to be healed. Pay special attention to what he tells you. Travel to the basement. Examine the Professor's inventions. Leave the Sandler home and enter the observatory. Talk to the Professor. Look through the Acme telescope. Travel to the meteor site. See *Zeke Zarmen* for additional gaming clues.

LOCATION OF OBJECTS

- 3-D Glasses Riviera Theater
- 8-ball Butch's Bar
- Army Uniform Barracks (MaCloud's Locker)
- Bottle Tepee
- Bowl Diner
- Dime Cola Machine (Tepee)
- Frobizmus Hose Gas Station's Garage
- General's Desk Key Head Quarters
- Grapes Diner
- Hotel Key Madam Chavez's Place
- Invisibility Belt Planet X
- Iodine Civil Defense Aid Station
- Iron Professor Sandler's Home
- Letters General's Desk
- Manila Folder Lady of the Evening
- Map Sheriff's Building
- Newspaper O'Malley's Store
- Pumpkin O'Malley's Store
- Pylon Tunnel 73
- Radioactive Isotope Laboratory
- Rubbing Alcohol Civil Defense Aid Station
- Self-recording Record Planet X
- Soap Jail Cell
- Staple Remover Gas Station's Office
- Stop Sign Street corner in Atom City
- Sulfur Civil Defense Aid Station
- Transmitter General's Car
- Whiskey Butch's Bar

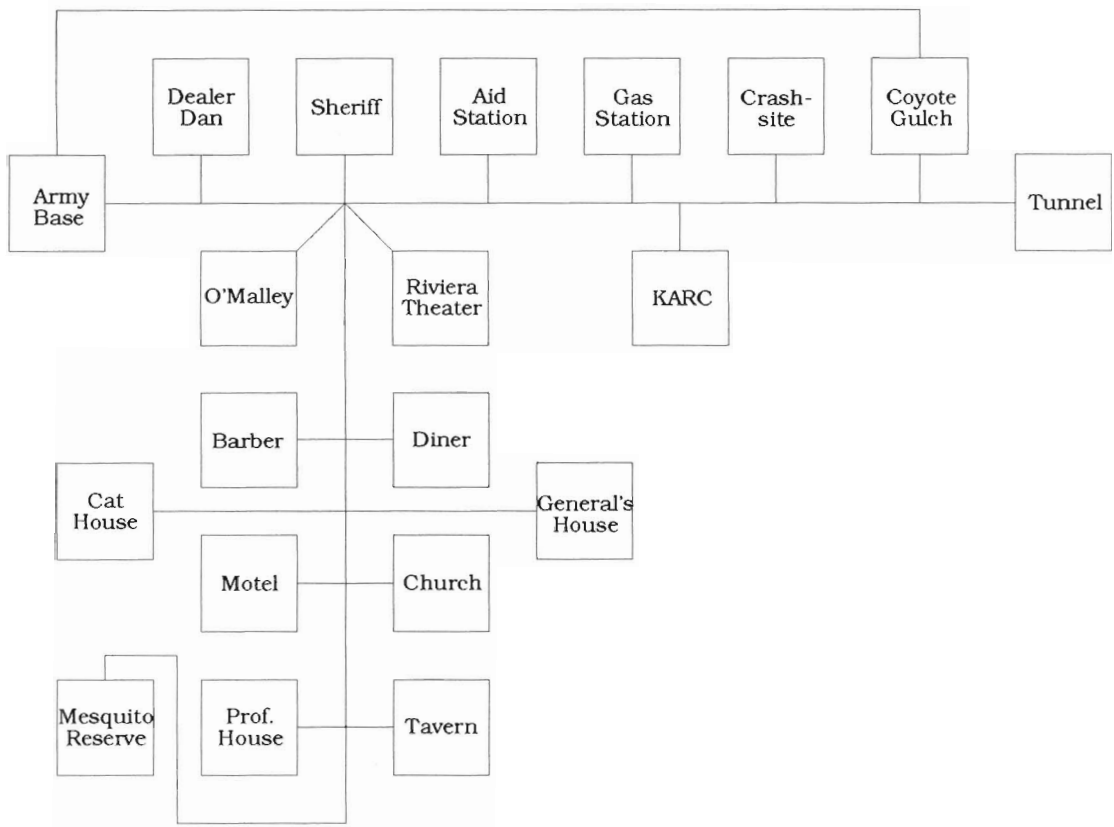

ATOM CITY

CHAPTER 6

EcoQUEST

GRAPHICS:	☆☆☆	STORY LINE:	☆☆☆☆
ARCADE:	N/A	INTERFACE:	☆☆☆☆
DIALOGUE:	☆☆☆	AUDIO:	☆☆☆
ANIMATION:	☆☆☆☆	LENGTH:	☆☆☆☆
OVERALL ANALYSIS: ☆☆☆☆			

SYSTEMS

- MS-DOS IBM-PC/Tandy & Compatibles

FEATURES

- Includes a FREE book with 55 fun ways to help save our planet.*
- Beautiful, hand-painted backgrounds and colorful underwater scenery.*
- Exciting animated undersea creatures.*
- A dynamic stereo soundtrack.*
- Fun, challenging, and educational ecological puzzles.*
- Extensive research and attention to detail create a realistic play environment.*
- For ages 10 and up.*



SCENARIO

Sierra On-Line came up with another winner! *EcoQuest: The Search for Cetus* is a luminous under-sea adventure that takes the entire family on a voyage of discovery. You play the role of a 12-year-old boy named Adam. His best friend and only companion is a talking dolphin named Delphineus. Together you must battle disastrous

toxic wastes, deadly fish nets, destructive oil spills, and a multitude of other catastrophes as you seek the great whale, King Cetus. During your perilous undersea quest, you'll encounter numerous spectacular scenes with lively animation and dozens of fascinating sea creatures. *EcoQuest* is a fun way to learn of the many dangers threatening the planet we call home. I must express my gratitude to Sierra On-Line for bringing us such a wonderful and educational game. I hope every adventurer takes the

opportunity to dive deep into the depths of *EcoQuest!*

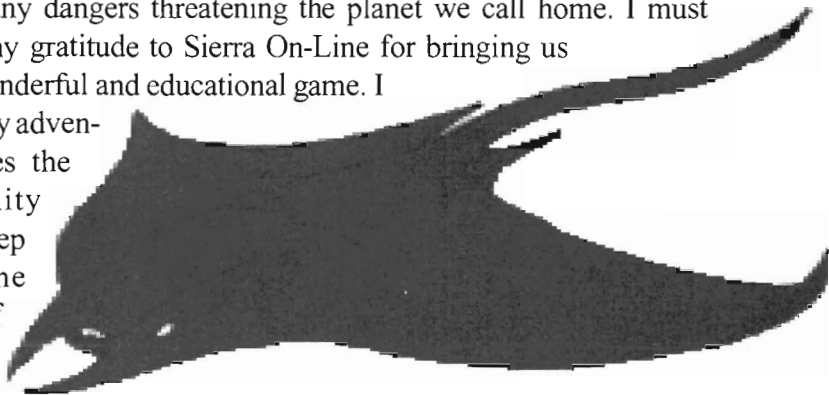

WALK-THROUGH

THE RESEARCH CENTER

Click the hand cursor on the bird (it's in the cardboard box). Click on the detergent, then on the clean rag. Click on the inventory icon and pour some detergent on the rag. Carefully use the rag to clean the bird. Now look at the gerbil and you'll notice that the poor guy doesn't have any water. You'll find the water bottle on the table

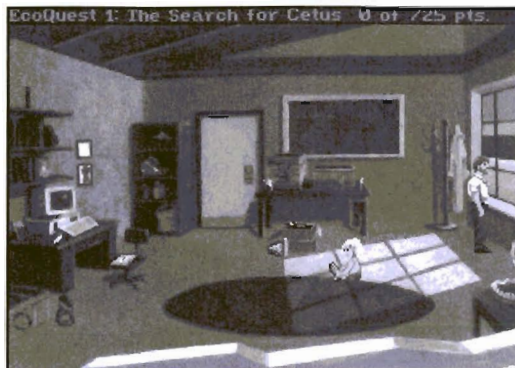

next to the cage. Look at the fish tank next to the gerbil cage. Pour in some experimental fertilizer solution to remove the oil. Walk to the computer and grab the envelope sitting on the swivel chair. Open it and you'll find a membership card. Click on the envelope to dispose of it properly. Click on the empty soda can next to the computer and dispose of it, too.

In front of the recycling bin you'll find Adam's garbage bag. Place it in inventory. Look at the computer screen and the books above it. Then look at the blackboard. After acquiring a minimum of 70 game points, leave this room and visit the dolphin. To leave the Research Center, exit through the back doorway (the off-disk copy protection access code is in the game documentation).

THE RESEARCH CENTER HOLDING TANK

Enter the Research Center tank room. Read the blackboard and follow the instructions to the letter. Talk to the dolphin three (3) times. Feed him a minimum of three (3) fish (the mackerels are located in the bucket below the blackboard). Climb into the tank and swim with the dolphin. Grab his fin and he'll give you a ride around the pool. Leave the pool. Grab the green frisbee located on the table below the blackboard. Throw the frisbee to the dolphin a minimum of four (4) times and suddenly you'll realize that Delphineus can speak! Take the scuba gear from the cabinet below the blackboard. Open the underwater hatch by moving the lever at the end of the gate, then put on the diving suit.

THE CRUISE SHIP

Swim north until you encounter a cruise ship dumping bilge (garbage) into the water. Use Adam's garbage bag to clean up as much of the floating debris as possible. Also, find the glass jar—you'll need it later in the game. Swim west. When Delphineus tells you to dive, save the game. Before diving, put on the scuba tanks. Swim south until you reach the seaweed. Now follow these directions:

- South
- Southeast
- Southwest

If you haven't made it to the underwater village known as Eluria, restore the game and try again. Eventually you'll make it through the thick seaweed.



ELURIA COURTYARD

Your first objective is to find the Oracle (and to clear away as much trash as possible). Before searching the ocean for the Oracle, find the steel cage and place it in inventory. After clearing the area of garbage, swim to the large bronze statue of Poseidon—the Greek God of the Seas.

Attempt to take his trident (spear). If he refuses to release his grip, swim to the majestic Temple of Poseidon. Look at the marble wall containing three eyeballs. Find the bronze conch shell located on the pedestal in the center of the Temple. Place this shell in inventory. Exit the Temple and swim back to Poseidon. Place the conch shell into the cupped hands of his servant and retrieve the trident. Swim back inside the Temple and use the trident to push the eyeballs simultaneously. You have just found the Oracle!

Talk to the Oracle and solve the tile puzzle. Use the onscreen help if you get into trouble. Once solved, the Oracle will ask you three riddles. Here are the answers:

- MAN
- FISH
- LOVE

GUARDIAN OF THE GREENS

It's time to visit the Guardian of the Greens. To get there from the Elurian Courtyard, swim west until you see a coral in the shape of a whale. Free this area of trash, then pour the experimental fertilizer solution over the coral whale. When the Guardian (lobster) appears, talk to her and she'll reward you with a bottle of healing potion. Did you notice the small shell that tumbled to the sea floor? Retrieve this shell and place it in inventory. Swim through the upper-left rock opening and you'll arrive at the Fish Apartments. Search the area for a thick cotton cloth. Use this cloth to clean the shell you received from the Guardian of the Greens. Swim east and you'll return to the Elurian Courtyard. Swim north to Tholos.

THE GREAT SENATOR

When the Senator speaks, place the bubble cursor on the golden mask and click the mouse button. The Senator will ask you to solve the riddle of the columns. Although this may seem impossible to do, it's actually quite simple. To your left you'll see three columns. Each column has three sections that can be turned by clicking the hand cursor on them. The trick is to match the left columns with the right ones. To do this, find a section of column that turns independently. Some sections, when turned, will turn other sections of a column. Find the sections that turn separately, then turn them until they lock into place. Find, and turn, the next section of column that revolves separately. Eventually all the sections will be locked into the correct position. After solving the column test, you'll meet Senator, the hermit crab. Talk to him and you'll learn his real identity is that of the Mayor. When the Mayor crawls back into his shell, summon him with the bubble cursor. Give him the shell (after cleaning it with the thick cotton cloth). It's time to convince the citizens to attend a town meeting. Leave Tholos by traveling west. Swim northwest and you'll reach the Fish Apartments.

THE FISH APARTMENTS

Properly dispose of all the junk obscuring this once-beautiful community. You'll be notified (by a window, a beep, and extra game points) when all the junk has been cleared away. Swim into the bottom-center apartment and say hello to Greg, the watchman. Show him the badge the Mayor gave you and he'll allow you to pass. When you see the poor blowfish trapped in a plastic bag, help him by clicking the hand cursor on him twice. After Narcissus has been freed from the plastic bag, he'll give you an algae-eating sea urchin. Thank him for the sea urchin and properly dispose of the plastic bag. Enter the bottom-left apartment. Say hello to Epidermis. After conversing with him, place the sea urchin on the algae (located on the east wall). Epidermis will give you a very sharp shell.

Hippocrates, the sword fish, lives in the right apartment of the middle row. Talk to him, then slice the plastic (wrapped around his jaws) with the sharp shell you received from Epidermis. Hippocrates will show his appreciation by giving you a pair of fish-bone tweezers. Before leaving, remember to dispose of the plastic. After entering the top-right apartment, you'll meet the sea turtle. Unfortunately, he can't speak because a deflated balloon is stuck in his throat. Use the tweezers to remove it. Erroneous will give you four metal screws. Don't forget to properly dispose of the deflated balloon. Enter the center apartment, located on the lower level. There you'll have the pleasure of meeting Gregarious A. Manatee. Poor Greg has been injured by a fishing boat's propeller and he's too frightened to surface for air. It's time to get Greg some good ol' oxygen. Swim north. Once you're above sea level, talk to the fisherman and show him the cage. Tell him that you can use the cage to cover the propeller. Using the inventory icon, attach the four metal screws to the cage. Then click the cage on the back of the fishing boat. After swimming back to the Fish Apartments, find the water pump and place it in inventory. Clean up the trash (that the fisherman dumped overboard) and enter the top-left apartment. Try talking to the lion fish. Find the bottle of bleach and dispose of it. Set up the water pump near the window and you'll save Olympia's life. She'll reward you with a poisonous lion fish spine. After the committee meeting, swim back to the Oracle. Use the trident on the eyeballs in the marble wall. Give the Oracle the golden mask of trust, which you received from the Mayor, then follow the dolphin. Once outside the Temple, swim south into the vast depths of the open sea.

THE UNDERWATER REEF

Welcome to the fascinating Underwater Reef. Swim east until you reach the Colossus head. Clean up the debris and find the mirror. Place the mirror in inventory, then swim two screens east. When you reach the octopus's cave, place the jar (which you found among the bilge) at the mouth of the cave, then swim one screen east. Upon your return, the octopus will have removed the lid from the jar. But before you retrieve the jar, notice the underwater maintenance vehicle in the current screen. Behind the front seat is a panel. Open the panel and remove the hacksaw. Swim to the toilet. Pry off the lid using the trident. Remove the rubber float and place it in inventory. Now get the fishing lure (it's dangling from one of the metal posts). Swim west and grab the jar.

While at the cave, click on the inventory icon and retrieve the mirror. Show the mirror to the octopus and he'll leave his domain. Get the coiled wire (cable) from the mouth of the cave. Swim one screen west and you'll be in the scene containing the brain coral. Enter the air pocket by swimming through the opening at the upper-left portion of the screen. There you'll meet the pirate ghost—who, by the way, has seen better days. Click the hand cursor on the Conquistador's pike (the wooden stake). You'll slip and fall. Climb back into the air pocket and repeat the previous instruction. Open the treasure chest. When the golden key drops into the water, dive in after it.

Hey, where did that red fish come from? Better get after him—he swallowed the golden key! After chasing the fish halfway across the ocean, you'll return to the scene containing the brain coral. Get the fishing lure from inventory and click it on the purple anemone (located at the bottom-left portion of the screen). Get the golden key. Swim three screens east and you'll reach a very large cave. Unfortunately, it's much too dark in there, so you'll need to find a light source. Swim back to the Colossus head and look in its ear. There you'll find a nocturnal flashlight fish. Get the jar (from inventory) and click it on the ear. The flashlight fish will swim into the jar.

Swim back to the cave. Click the jar (containing the flashlight fish) on the center of the cave. The fish will leave the jar and illuminate the cavern. Locate the opening covered with rocks. If you can't see the rock-covered opening, read the following (unconventional) hint. If you have found the rocks, skip the following hint.

Hint: *Adjust the brightness control knob on your computer monitor, to its brightest position. You should now see the rock-covered opening.*

Using the hand cursor, remove the rocks one by one. After all the rocks have been removed, find the metal box. Unfortunately, the lock is rusted and cannot be turned. Somehow you'll need to oil it. Remember the rag you used to clean the oil off the conch shell? Use this rag to oil the lock. Get the golden key from inventory and click it on the metal box to open it. Remove the protective clothing. To rid the sea of the poison drums, you'll need the following items:

- Rubber float
- Transmitter
- Cable

Hint: *The rubber float can be found in the toilet. The transmitter was given to Adam by his father. The cable can be found in the octopus's cave.*

Assemble these items, then click the assembly on the drum displaying the skull and crossbones. The transmitter will notify the Coast Guard of the toxic debris; they'll take care of it.

CETUS

Swim north and you'll find a sunken harpoon vessel. Look at everything. Try opening the cabin door. Eventually, the fearless Flesh-Eater will arrive. For god's sake, swim for your life! When you get caught in the drift net, use the sharp shell to cut your way free. Swim back to the sunken harpoon vessel. Use the trident to pry open the door. Swim through the cabin until you reach the stern. Follow the path of the steel cable. When you reach the surface, you'll see the mighty Cetus. Talk to him until he slips into unconsciousness. Swim south, then into Cetus's mouth (make sure it's open). Once inside Cetus's mouth, click on

the inventory icon and retrieve the hacksaw. Saw the tip off the harpoon. Exit the mouth. Pull the harpoon using the hand cursor. Look at the wound and you'll notice that it has become badly infected. Remember the healing potion Demeter gave you? Use it on the wound.

After healing the whale, it's time to save Delphineus. Swim into the beast's lair and cut the drift net with the sharp shell. Now you must help Cetus defeat the Flesh-Eater. Click on the inventory icon and get the poisonous lion fish spine. When you think the time is right, attack the manta. But be careful, timing is very critical. Congratulations! You just saved Cetus from the terrible Flesh-Eater.



LOCATION OF OBJECTS

- Air Tanks Holding Tank
- Badge Mayor
- Bleach Bottle Olympia’s Apartment
- Bottle Research Center
- Bronze Conch Shell Temple of Poseidon (Pedestal)
- Cable Octopus’s Cave
- Certificate Adam’s Desk Chair
- Detergent Research Center
- Envelope Adam’s Desk Chair
- Fertilizer Solution Research Center
- Fish-bone Tweezers Hippocrates
- Fishing Lure Underwater Metal Post
- Flashlight Fish Colossus Head
- Frisbee Holding Tank (Table)
- Golden Key Pirate Ghost (Purple Anemone)
- Golden Mask Mayor
- Hacksaw Underwater Maintenance Vehicle
- Healing Potion Demeter
- Jar Cruise Chip (Bilge)
- Lion Fish Spine Olympia
- Mackerels Holding Tank (Bucket)
- Membership Card Adam’s Desk Chair
- Metal Screws Erroneous
- Mirror Colossus Head
- Protective Clothing Metal Box (Cave)
- Rag Research Center
- Recycling Bin Research Center
- Rubber Float Underwater Toilet
- Scroll Oracle
- Scuba Gear Holding Tank (Cabinet)
- Sharp Shell Epidermis
- Shell Guardian of the Greens

ECOQUEST

- Soda Can Adam's Desk
- Steel Cage Eluria Courtyard
- Thick Cotton Cloth..... Fish Apartments
- Transmitter Research Center
- Trident Poseidon
- Urchin Narcissus
- Water Pump Fish Apartments

MAPS

RESEARCH CENTER/OCEAN

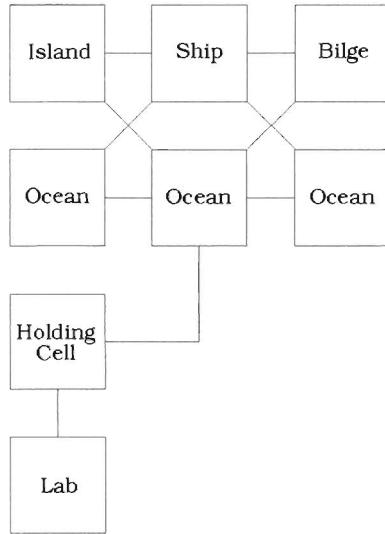

FISH APARTMENTS

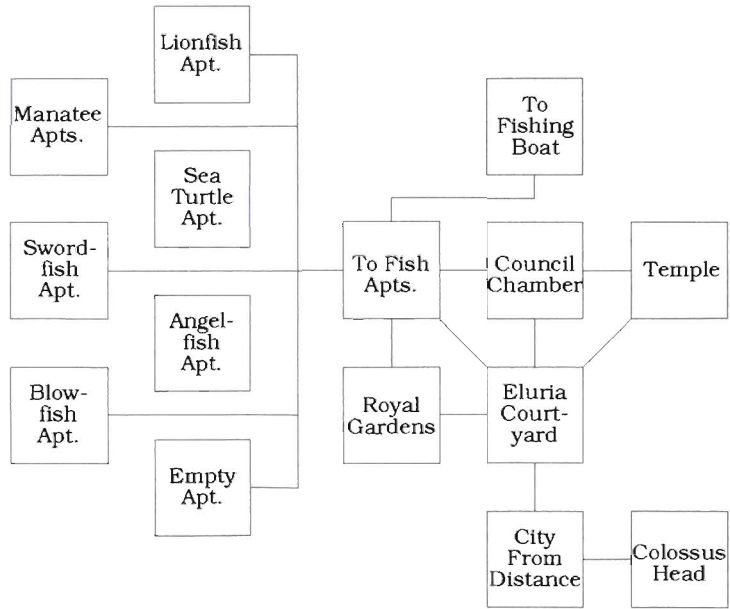

REEFS/CETUS

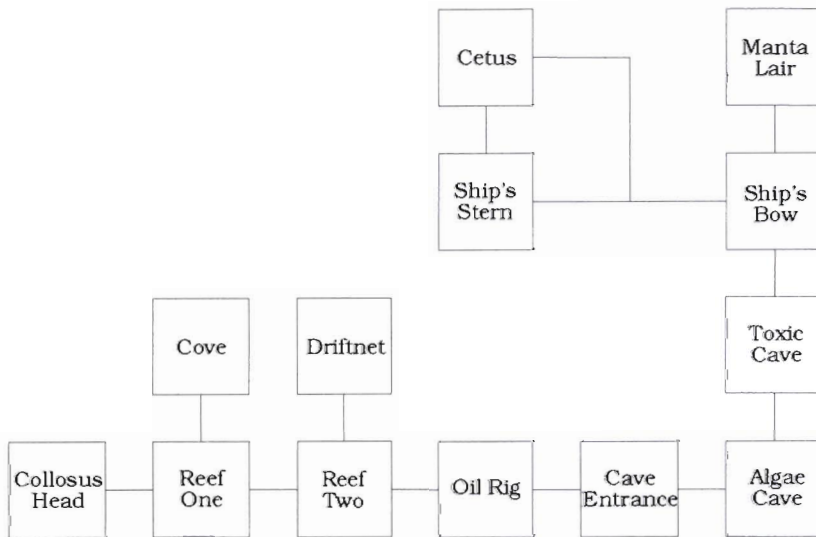

CHAPTER 7

STAR TREK

GRAPHICS:	☆☆☆	STORY LINE:	☆☆☆☆
ARCADE:	☆☆	INTERFACE:	☆☆
DIALOGUE:	☆☆☆	AUDIO:	☆☆☆
ANIMATION:	☆☆	LENGTH:	☆☆☆☆
OVERALL ANALYSIS: ☆☆☆			

SYSTEMS

- MS-DOS IBM-PC/Tandy & Compatibles
- Amiga

FEATURES

- Full 256-color VGA graphics.*
- Thousands of state-of-the-art, 3-D digitized space action scenes.*
- Interaction with dozens of alien races.*
- Navigation of Kirk, Spock, and Bones on a variety of world explorations.*
- Complete musical score featuring digitized sound effects from the series and major sound board support.*
- Easy to use, point-and-click icon interface.*

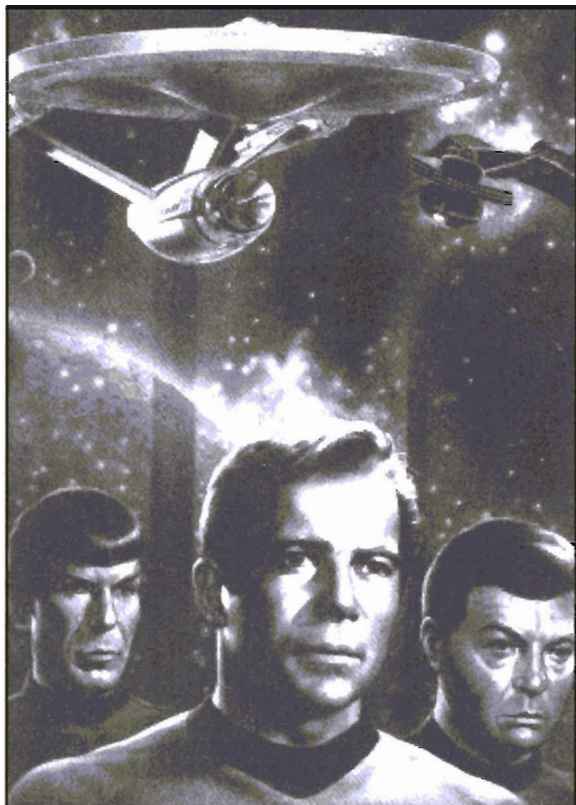

SCENARIO

“Beam me up, Scotty...”

Star Trek: 25th Anniversary by Interplay combines a simple 3-D starship simulator with a medley of mini-adventures. This combination creates a stunning game that’s divided into two unique sections: piloting the U.S.S. *Enterprise* (simulation) and planet-side or aboard another starship (adventure). You, as Kirk, will have complete control over a Federation Starship. Communicate with Star Fleet Command, Uhura, Spock, Scotty, Sulu, and Chekov while navigating the *Enterprise* through a galactical voyage climaxing

at the final frontier. If the *Enterprise* is under attack, immediately raise the shields and fire phasers and photon torpedoes to defeat the enemy. In standard orbit, use the ship’s sensory scanners to gain pertinent information about other planets and starships. Then gather a landing party and use the transporter to beam down and interact with alien races. As you visit other planets and starships, you’ll have direct control over Kirk, Spock, and Bones. If an injured person needs medical attention, place Bones in control. If an alien machine’s too complicated for Kirk to operate, Spock may be your best bet, and so on. You’ll be amazed by the seemingly endless, vibrantly colored graphical scenes used throughout the game, including many of alien landscapes. Along with awesome graphics, a strange sense of humor (as in the TV series) that had me chuckling through each mission has been blended into the story line. So fasten your seat belt and continue a quarter-century of exploration that’ll test your skills—at warp speed (airbag not included).

TREK-THROUGH

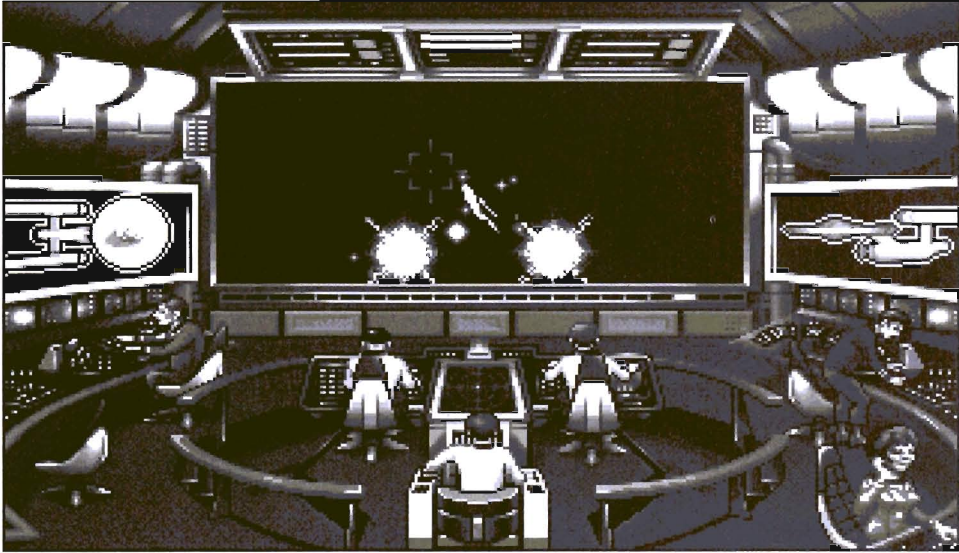

THE COMBAT SIMULATION

The game begins on the bridge of the U.S.S. *Enterprise*. The Captain's Log window will appear. Read it carefully, then click on the top icon to begin the simulation. Mr. Spock will inform you that the *Republic* is arming weapons and raising her shields. I suggest doing the same by pressing the following keys:

- S*—Shields
- W*—Weapons

Of course, you can perform the same functions with the mouse, but before dabbling with the somewhat confusing interface, I strongly suggest using the keyboard—otherwise you may lose the mock mission. After arming the weapons and raising the shields, pause the game by depressing the following key:

- P*—Pause/Unpause

STAR TREK

Directly above Kirk is the radar screen. The blue dot is the location of the *Republic*. The U.S.S. *Enterprise* is the white dot at the center of the radar screen. Now unpause the game by pressing the following key:

❑ *P*—Pause/Unpause

The speed of the *Enterprise* can be adjusted using keys 1-9, nine being the fastest. To attack your opponent, first adjust the speed of the *Enterprise* by pressing the following key:

❑ 3 (DO NOT use the numeric keypad)

I know what you're thinking . . . *Why should I set the speed to 3 if 9 is available?*
Answer: It's much easier to keep the enemy in your sights when he must orbit his starship around yours, rather than your having to orbit around his.

Move the *Enterprise* cursor in the direction of the blue dot on the radar screen. When the *Republic*'s in target range, fire the phasers and photon torpedoes by clicking both mouse buttons simultaneously. For a panoramic view, press the following key:

❑ *V*—View

If you defeat the *Republic*, you can continue with the quest. If the *Republic* has defeated you, however, I suggest starting the game over because your combat skill must be developed further. If you've won the simulation, a message will appear from Star Fleet. The Admiral will assign you to your first mission: Travel to Pollux V. Before traveling there, familiarize yourself with the bridge and the crew. Begin by striking the following key to switch from the *Enterprise* cursor to the hand cursor:

❑ Tab—Cursor selection

Click the hand cursor on Kirk and three icons will appear:

- ❑ Captain's Log
- ❑ Transporter
- ❑ Options (Save, Restore, etc.)

Experiment with all three icons, then click the hand cursor on Spock. Talk to him. Use the ship's computer to obtain more information about your destination. To accomplish this, click on the computer icon and enter the following:

- ❑ POLLUX-Enter

Click the hand cursor on the remaining crew members to get acquainted with their functions. In the game documentation (on pp. 2-5), you'll find a picture of each icon along with a function description. You may find it easier—and even faster—to strike the equivalent letter on the keyboard, however. Instead of clicking on Chekov and then having to click on the weapons icon, for example, simply strike the *W* key to perform the identical function.

DEMON WORLD: POLLUX V

To reach Pollux V, strike the *Navigation* key or click the hand cursor on Chekov and then on the navigation icon. This will bring up the United Federation of Planets. On pp. 8-9 of the game documentation, you'll find the location of all the planets used in this game. Find Pollux V (No. 19), then move the circle cursor over that planet and click the mouse button (this is the off-disk copy protection). After arriving at Pollux V, press the following key to enter standard orbit:

- ❑ *O*—Orbit

Strike *Tab* to switch to the hand cursor. Click on Spock and he'll relay the results of the ship's sensory scan. Click on Lieutenant Uhura, then on the send icon. Communicate with the Priest. He'll ask you to transport to his planet. Click on Kirk, then on the transporter icon.



STAR TREK

Move the cursor over Kirk and click the right mouse button. This will bring up the command icon. The command icon provides you with the following functions:

- Mouth* Talk
- Eye* Look
- Hand* Get
- Ball* Use
- Starfleet* Game options

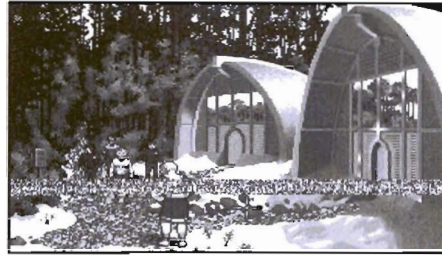

Talk to your crew, then to the Priest. Use the following dialogue responses when conversing with the Priest:

- 1-1-1

Enter the southernmost building and talk to Brother Stephen. Use Dr. McCoy's medical Tricorder on Brother Chub. Exit the building and travel along the north path. When you reach the mouth of the cave, quickly retrieve the phaser set to full power (red handle) and fire at the Klingons. After killing all three Klingon clones, get the detached hand. Walk to the cave entrance and pick a sample of red berries.

Walk to the location of the buildings, but this time enter the northernmost building (the study and lab). Once inside, find the Antiquated Molecular Synthesizer. Place the berries into this machine and it'll synthesize them into a hypo-dytoxin. Exit the lab and enter the chapel. To cure Brother Chub, give him the hypo-dytoxin. Walk back to the lab and place the Klingon hand on the multipurpose work space located in the center of the room—Spock will want to work on it. Find the glass case and retrieve the twisted piece of metal, then head back to the cave. Fire the phaser at the rocks, working from the top down. After the rocks have been disintegrated, you'll notice an injured colonist. Talk to Brother Kandrey, the colonist. To cure him, use McCoy's Tricorder and medical bag on him.

To open the door, place the Klingon's hand on the panel. Walk through the tunnel and into the circuitry room. Find the panel containing three levers. Set the levers so that only one light appears (centermost position). If the settings are

correct, Navian the alien will appear. Greet him using the following responses:

2-2

Give Navian the key (twisted metal artifact) and he'll turn off the machine. Congratulations, you just completed your first mission! Now it's time to pilot the U.S.S. *Enterprise* to your next destination, Beta Myamid.

HIJACKED: BETA MYAMID

Star Fleet Command has just given you your next assignment: Locate the disabled U.S.S. *Masada*. Using the map in the game documentation, find Beta Myamid, then travel there using the *Navigation* key. Unfortunately, along your journey you'll encounter a hostile enemy. After communicating with the Elasi Captain, quickly raise the shields and arm weapons.

Yes, Captain, this is the real thing!

Do your best to rid the universe of the Elasi Captain. Once he's been defeated, enter standard orbit. Click on Lt. Uhura to hail the U.S.S. *Masada*. You'll be greeted by the pirate Elasi Cereth. Use the following responses:

1-1-1

Talk to Spock. Use the ship's computer to obtain the prefix code necessary to lower the *Masada*'s shields. The prefix code is

293391-197736-3829

To send the code, click on Lt. Uhura. Beam aboard the *Masada* using the transporter icon. When you reach the transporter room of the *Masada*, have McCoy tend to the injured crew member. After reviving the crew member, he'll show you where he keeps his tools. Take the Runcinate Transmogriifier that can be used to temporarily fix key circuits. Leave the transporter room by walking east. Get the trash (it's below the yellow valve). The door to the brig is located on the right side of the corridor (steer clear of the red doors, as they're guarded

by a very powerful force field). Enter the brig and use the stun phasers on the Elasi guards. Next have Spock use the science Tricorder on the panel next to the blue-colored cell. To have Spock rewire the panel, click on the use icon, then click on Spock, and, finally, click on the wires below the panel. After Spock has defused the bomb, click on the panel to free the crew members.

Exit the brig and return to the corridor. To disarm the force field, click on the red phaser, then on the phaser welder. Use the phaser welder on the bottom-left portion of the red door. Walk through the north doorway and you'll find yourself on the bridge of the *Masada*. Talk to the pirates using choice No. 1. This should end the mission. If the *Masada*'s going to crash, use the communicator and Sulu to save the ship. Save the game.

LOVE'S LABORS JEOPARDIZED: *ARK-7*

When you arrive at *ARK-7*, you'll be greeted by a Romulan warship. And I'll be quite honest with you, the Romulan Captain isn't very pleased by your presence. Furthermore, this guy is one hell of a pilot! If you run into serious trouble, strike the following key to help boost repair time:

E—Emergency Power

After defeating the Romulan Captain, talk to Spock, then to Lt. Uhura. You'll receive a message from Centurion Preax. After reading his disturbing message, beam aboard *ARK-7*.

Welcome to the bridge of the *ARK-7*. Begin the mission by using Spock and McCoy on the computer. Using McCoy a second time will give you access to the computer's database. After reading the computer files, walk into the synthesizer room via the north doorway. Click on the left cabinet and get the antigravity unit. Walk one screen east. Walk through the north doorway into the engine room. Find and take the wrench. Use the wrench to open the compartment of the left computer. Get the insulation. With the same wrench, remove the grill from the vent located along the east wall. Click on the panel located to the right of the vent. Using the same wrench, disconnect the nozzle of the Nitrogen canister from the hose. Finally, use the antigravity sled to retrieve the canister.

Walk south into the Lab. Find the Distillator and place the insulation (colored wires) into the machine. It'll produce a substance called Polyberylcarbonate

(whatever that is). To reach the synthesizer room, walk west (through the farthest doorway). Use the wrench (on the nozzle) to turn on the gas. Click the Polyberylcarbonate on the door of the synthesis chamber and use Kirk on the synthesizer controls. Remove the TLTDH gas. Use the wrench to shut off the gas. Using the anti-gravity sled, replace the oxygen canister with the nitrogen canister. Turn on the gas and use Kirk on the controls of the synthesizer. Retrieve the bottle of ammonia and walk through the east doorway.

While in the lab, locate the freezer along the west wall. Get a specimen dish and locate the Reproducer. Place the Oroborus virus specimen into the chamber of the Reproducer. Place the canister of ammonia (blue bottle) on the nozzle of the Reproducer. Now it's Dr. McCoy's turn. Use McCoy on the controls of the Reproducer. Get the cure and walk through the doorway farthest west. Once you're back in the synthesizer room, place the cure in the chamber of the machine. Use Kirk on the controls. Get the hypodermic syringe and use it on Spock. After Spock has been cured, walk east, then north.

From within the engine room, use the canister of TLTDH (red bottle) on the open vent. If a grill is covering the vent, use the wrench to remove it. Walk south, then climb down the ladder. Once below deck, use the hypodermic syringe on the Romulans. Walk through the north doorway marked *Restricted*. Use the cure on the Romulan Preax. Untie the hostages. Walk near the Preax. Talk to him using choice No. 1 and the mission will end.

ANOTHER FINE MESS: HARRAPA

Another fine mess awaits you in this amusing mission. Begin by traveling to System 5, Harrapa. After beaming aboard the alien vessel, you'll find yourself in the cargo room. Get the Dodecagons (spheroid), the degreaser, and the lens. Use the lens on the degreaser, then use this object anywhere in the ship.

Travel three screens north and you'll reach the bridge. Retrieve the engineering instrument located just above Spock's left shoulder. Use Spock on the control panel. Enter the computer room by walking southwest. Use Spock on the yellow Dodecagon (spheroid) located in the center of the room. Use the Tricorders on the spheroid. Next use the spheroid (from inventory) and click it on the spheroid in the center of the room. Exit the room through the east doorway.

Welcome to the weapons room. Use Spock on the blue triangular buttons, then on the pink button. Reply using choice No. 2. Travel north to the medicine

STAR TREK

room. Here you'll find Harry Mudd up to his old tricks. This would be a good time to introduce Harry to Spock's Vulcan grip. To do this, use Spock on Harry. While Harry lies unconscious, use McCoy on him. Then have McCoy retrieve the medicine from above the control panel. Use the medicine on the control panel. Click McCoy on Mudd. Enter the computer room by traveling two screens west. After talking to Mudd (and the life support system is still operational) go to the bridge. If the life support system needs work, go to the other end of the ship and fix it. Once you're on the bridge, use Kirk on the controls. Then use the following communication responses:

- ❑ 1-3-1

THE FEATHERED SERPENT: DIGIFAL

After entering Digifal System (No. 7), you'll be greeted by a Klingon battle cruiser. Use the following responses when communicating with the Klingon:

- ❑ 2-1

Enter standard orbit and talk to Spock. Enter the transporter room. Use the following responses with Que:

- ❑ 1-2-1

Que will become quite irate and send you into a deep pit. Pick up some rocks (you'll find them lying north of Kirk). To catch the snake, place a rock in front of the snakehole. To get the vine, throw a few rocks at it. Climb the double vine, then travel west until you encounter a native named Tlaoxac. To get past the native, use the snake on him, then use the snake on Kirk. Get the knife and walk west (below the native). Follow the path until you reach a canal. To get past the water monster, you'll need to find the poison fern. Use the knife on the fern. Use the poison fern leaf on the water monster. To reach the cave, walk across the fallen log. Once inside the cave, find the Dilithium crystals. Use the knife on them to pry one loose. Travel west.

THE TRIAL

To begin the trial, walk to the center of the room. Use response No. 1 during the entire conversation. After the trial, you'll be locked in a room with an electrical alien. To get past it, use the red phaser on the rocks at the lower-right corner of the screen. Get a board and place it in the molten rock. Use this board on the alien. To open the door, use the Tricorder on the panel. Contact Uhura and give her the Tricorder readings. Use the following choices when responding to Uhura:

2-1

Use Spock on the locking mechanism. Enter the gem room. Place the green gems in the holes of the pedestal. Walk into the yellow light and use response No. 3.

THAT OLD DEVIL MOON: ALPHA PROXIMA

After reaching Alpha Proxima, enter standard orbit and hail the planet. Consult the computer about Proxima, Proxtrey, and Scythe. Transport to the planet's surface. Gather some rocks (take more than one). Walk to the large door and use Spock on the controls. Enter the base number for 99:

10200

Enter the sentry chamber. Use the Tricorder on the computer terminal and on the security lock. Use Spock on the computer terminal, the writing on the door, and the security lock. Enter the base number for Scythe:

122

Walk north into the keypad room. Use the Tricorder on the locked door and on the keypad. Enter the drilling room by walking east. Use the Tricorder on everything. Locate the red box and remove the wiring. Have Spock program the drill by using the Tricorder on the control panel. Use Spock on the control panel and set it to

100

STAR TREK

Place the rocks in the path of the laser beam, then use Spock on the controls, setting them at

❑ 001

Pick up the duplicate pass and walk west. Use the pass on the keypad and the door will open. Use the Tricorder on all three computers. Then use the wire on either the right or left computer terminal. Finally, use Spock on the left computer terminal.

VENGEANCE: THE FINAL BATTLE

Beam aboard the crippled U.S.S. *Republic*. Use McCoy on the injured crew members. Use the Tricorder on both the Captain's chair and the ship's computer. Walk south, from the bridge, into Sickbay. Use McCoy on Brittany and she'll reveal the *Republic*'s status. After she falls unconscious, use the communicator to beam aboard the *Enterprise*.

Prepare for the most difficult simulation sequence in the entire game. Once aboard the *Enterprise*, I strongly suggest saving the game. And by the way—good luck, Captain!

MAPS

DEMON WORLD

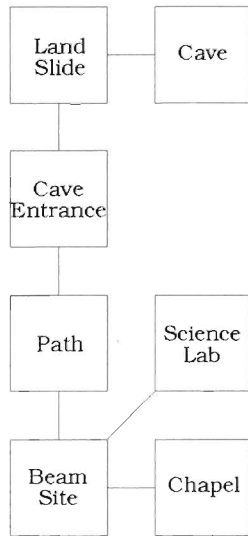

HIJACKED

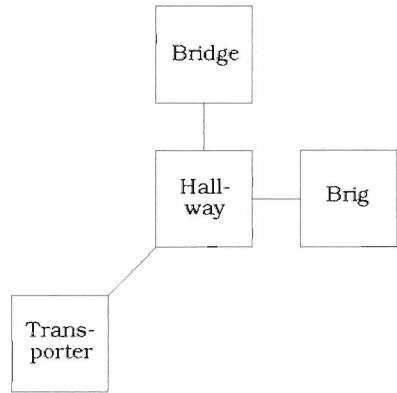

ANOTHER FINE MESS

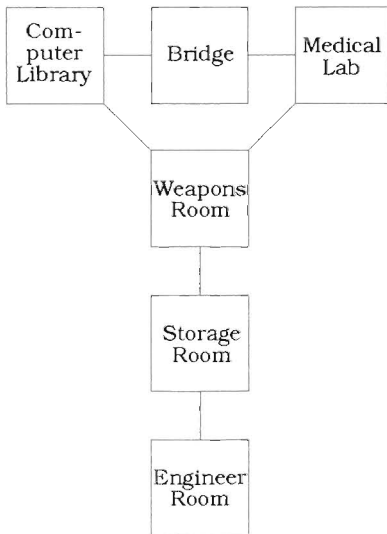

LOVE'S LABORS JEOPARDIZED

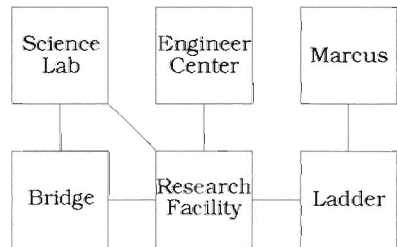

FEATHERED SERPENT

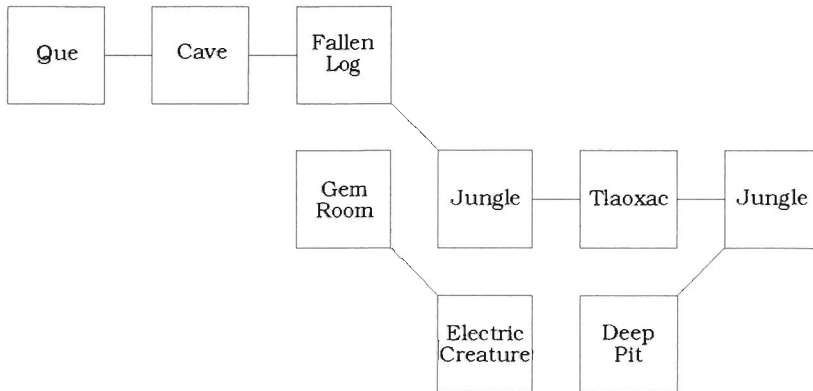

THAT OLD DEVIL MOON

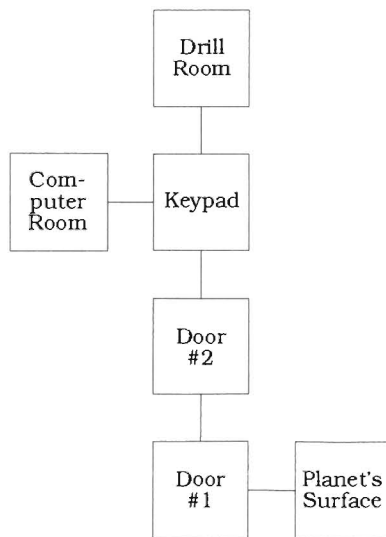

CHAPTER 8

SPACE QUEST IV

GRAPHICS:	☆☆☆	STORY LINE:	☆☆
ARCADE:	☆☆	INTERFACE:	☆☆☆☆
DIALOGUE:	☆	AUDIO:	☆☆☆
ANIMATION:	☆☆☆	LENGTH:	☆☆☆
OVERALL ANALYSIS: ☆☆☆			

SYSTEMS

- MS-DOS IBM-PC/Tandy & Compatibles
- Amiga
- Macintosh
- CD-ROM

FEATURES

- Hand-painted, futuristic color graphics.*
- The most realistic animation you've ever seen in an adventure game.*
- No typed-in commands—point and click to perform game actions.*
- Scrolling screens—the first ever in a Sierra adventure.*
- Another terrific rock 'n' roll soundtrack, with even more realistic sound effects.*

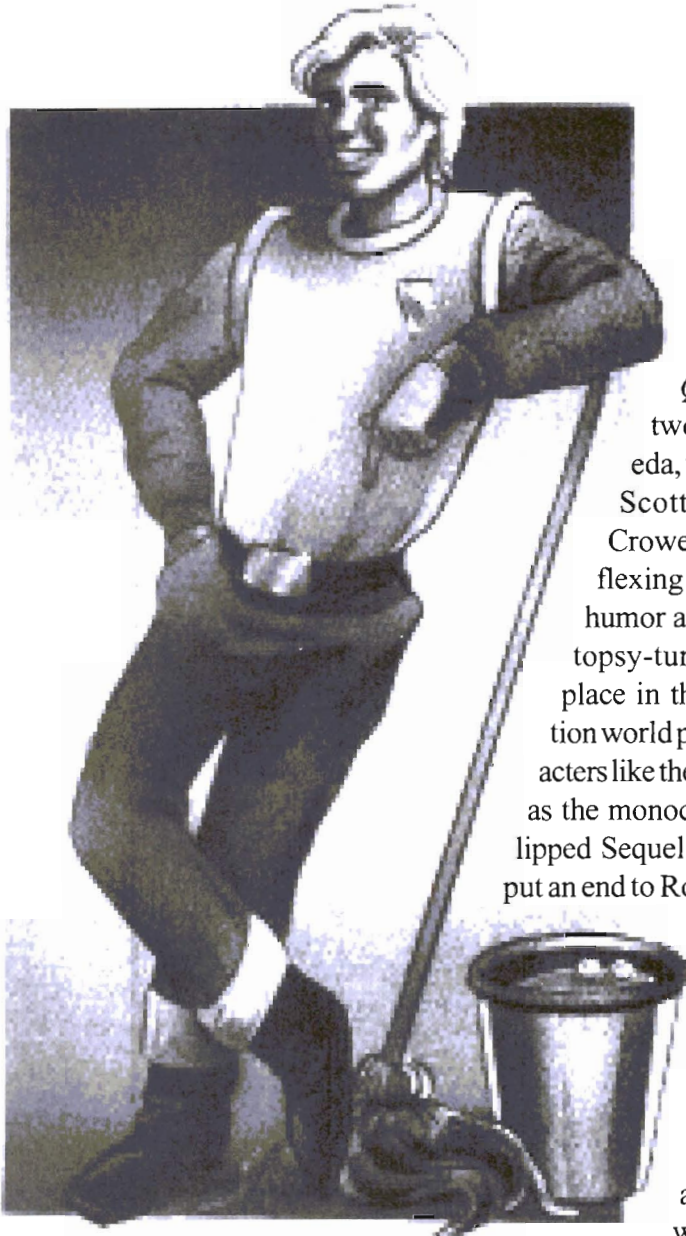

SCENARIO

Strap on your jetpack, buckle your anti-gravity boots, and gulp a big handful of Dramamine—it's time to trek through another zany chapter of the award-winning *Space Quest* series. Yup, those two guys from Andromeda, frequently mistaken for Scott Murphy and Mark Crowe of Sierra On-Line, are flexing their kooky sense of humor again in this fast-paced, topsy-turvy adventure taking place in the farcical science fiction world peopled by bizarre characters like the resentful aliens known as the monochrome boys; the stiff-lipped Sequel Police who are out to put an end to Roger and any forthcoming sequels; and the sexy Latex Babes who love to hear Roger scream in sheer agony. And if that doesn't wag your tail, prepare to flip burgers at Monolith Burgers, wear women's clothing,

and pilot spacepods throughout the galaxy. Where else can you do all this but in *Space Quest IV*?! And as the Andromeda boys would say: *May the farce be with you ...*

WALK-THROUGH

XENON

After the introduction, you'll find yourself on the streets of Xenon. Begin the adventure by walking east. Get the rope. Walk two screens west and you'll reach a disabled surface transport vehicle (skimmer).



The wandering cyborg.

Hint: *Avoid the wandering cyborg. Although he's as blind as a bat, his shriek will alert the security droid. You can escape the cyborg, but not the security droid.*

Click the hand cursor on the skimmer, then on the glove box. Remove the PocketPal laptop computer. Leave this scene by walking north. When you encounter a corroding battle vehicle, look in the hole and you'll see a bottle of unstable ordnance. DO NOT take the ordnance: It's very unstable and will explode the second you attempt to leave the streets of Xenon. Walk north until you reach the old bank (the green building). Duck into the foyer. Click the rope on the sidewalk and wait for the pink rabbit. When it appears, click the mouse button to snare the hare. From the bank, walk two screens east and one screen south. Open the center sewer grate. Enter the sanitation office. Get the empty jar from the desk. Look under the old-fashioned desk blotter. Save the game. To enter the sewer, click on the hatch located along the west wall. Walk around the sewer until you see green slime oozing from one of the vents. Using the jar you found on the desk, carefully collect some slime. DO NOT touch the slime. After filling the jar with slime, hurry to the west side of the sewer. Click the hand cursor on the ladder.

Wait patiently for the police to exit the spaceship, then click the walk cursor on the spaceship. Walk one screen west. Click on the landing-gear compartment

SPACE QUEST IV

and enjoy the flight to the Super Computer landing bay.

When you reach the landing bay, save the game. Then walk one screen west. Wait for a second pod to appear, then click the hand cursor on it. Refer to pp. 8-9 of the *Spacepiston Magazine* to pass the off-disk copy protection. Copy the six green symbols (above the keypad). These are the coordinates for Xenon—you'll need them later in the game.

Hint: Copy the six green symbols.

Enter any six symbols and strike the *ENT* button. Repeat this procedure and you're on your way to Estros.

ESTROS



Welcome to Estros. Exit the pod by pushing the red button on the left door. To avoid being caught by the Sequel Police (yes, they're here, too), immediately walk west and approach the rock formation. Be careful not to fall off the edge. Wait until you see a giant shadow being cast from above. Walk back to the

pod and travel down the stone stairway. After your unexpected journey, search the police officer.

Hint: To reveal a partial destination coordinate, click on the inventory icon. Then click the hand cursor on the piece of gum wrapped in paper.

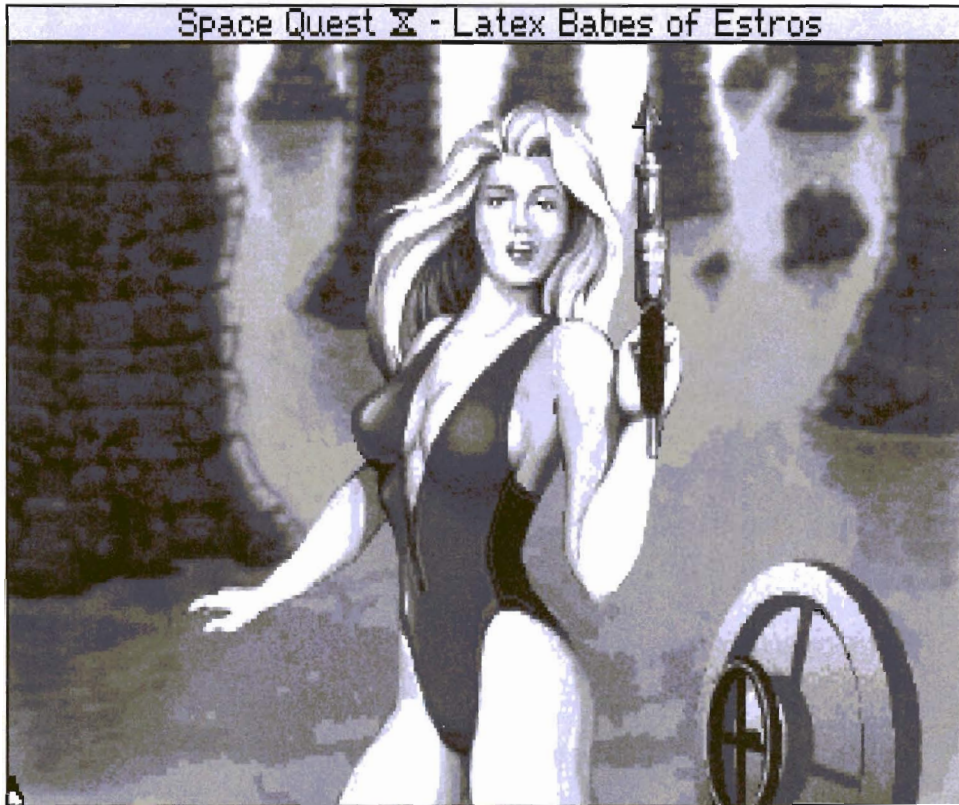

WOW! What a weapon!

Walk through the hole located in the southeast corner of the nest and say hello to the shapely Latex Babes. And what should you do when you encounter beautiful women packing guns? Save the game, dude!

Click on the hatch to enter the submarine. After the animation sequence, you'll encounter your worst nightmare—the EpiRip 357! Fortunately, a giant sea slug makes an appearance, thus saving you from a hair-raising encounter. Unfortunately, however, the slug wants to eat you for dinner. To escape the sea slug, click on the red button when its tentacles reach your legs. This will fire the same laser that removed the lower portion of your pants. Click on the nearest air tank and throw it into the slug's mouth.

After defeating the sea slug, the forgiving Latex Babes will take you to their favorite hangout, Galaxy Galleria: the largest, hippest shopping center west of the galaxy.

GALAXY GALLERIA



Instantly the Babes spot a sale and they're off. Won't they be surprised after they realize they dropped their AutoBucks Teller Machine card? Get the card. Now, considering the fact that you don't have any shoes and you're

missing the bottom half of your pants, it'd be advisable to purchase new clothing at Big and Tall. Go to the far walkway and travel west. Enter Big and Tall. Talk to the clerk—he'll give you what you need. Pay for your new clothing. Since you're in dire need of cash, travel to Monolith Burgers. Ask about a job. After getting fired, your ex-boss will toss a cigar butt onto the walkway. Get the cigar butt.

Find the teller machine. Use the ATM card. If it doesn't work (and at this point it won't), go to the women's clothing store. Talk to the clerk. Pay for the merchandise. Travel back to the teller machine and *clean house*.

Travel to MY favorite store, the Software Store. Locate the bargain bin. Using the hand cursor, move the boxes until you find the (cough, cough) hint book for *Space Quest IV*. Purchase the hint book by clicking the look cursor on it. Travel west. Enter Radio Shock. Talk to the robot and familiarize yourself with the interface. Don't buy anything at this time: Later in the game you'll need to return here and purchase a PocketPal adapter.

Travel to the Arcade and look for the game entitled Ms. Astro Chicken (it's along the west wall). After playing a game or two, get your original clothes from the dressing room in the women's clothing store. Travel back to the Arcade. Save the game. Enter through the east entranceway and walk to the back of the store. (Be prepared to run from the Sequel Police.) After the Sequel Police arrive, leave the store and enter the Skate-O-Rama. Float north, then east (be sure to travel one screen north). Continue floating east. Exit the Skate-O-Rama.

Cross the first walkway and travel west. Enter the Arcade. Enter the Sequel Police's time pod. Copy down the coordinates. To find the time coordinates for your next destination, you'll need the following items:

- The SQ4 hint book
- The bubble gum wrapped in paper

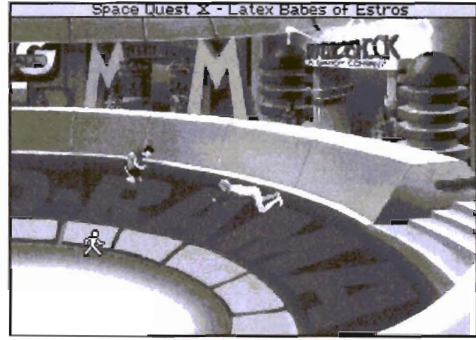

Click on the inventory icon and use the hand cursor on the hint book. Find the following question:

- I'm in the stupid time pod. Where else can I go?*

Click the pen on the fourth clue and copy down the first three symbols of the time coordinates. Click on the inventory icon and use the hand cursor on the bubble gum wrapped in paper. There you'll find the three symbols necessary to complete the time coordinates. Enter these symbols into the coordinate panel. I'll see you at Ulence Flats.

ULENCE FLATS

Exit the pod and travel south. Enter the bar and talk to the monochrome boys. To get back at them for throwing you out of the bar, kick over their sand bikes. Now what are you waiting for? Run for your life!

After eluding the monochrome boys, save the game. From Tiny's Used Spaceships, walk east. Be prepared to dodge a monochrome boy. To avoid him, click the mouse button just before he strikes you. Enter the bar. Get the book of matches. Travel to the time pod (watch out for the monochrome boy). Enter the pod and punch in the coordinates for Xenon.

THE SUPER COMPUTER

Exit the time pod. Walk two screens east. To open the door leading to the Super Computer room, pour the green slime on the locking mechanism. Click the hand cursor on the door to open it.

SPACE QUEST IV

From within the tunnel, click on the inventory icon. Use the book of matches on the cigar butt. Click the cigar butt on Roger: The smoke will illuminate the laser beams. Click the eye cursor on the keypad. To get through this corridor, enter the correct angles to align the laser beams in a vertical position. The correct angles (from their initial positions) are

- 1-5-6
- 0-2-4
- 1-0-8

Walk west. Enter the Super Computer room. Look at the nearest terminal box (the little gray box along the railing). Look closely at the plug. Make a sketch of this plug, since it varies in each game. Travel back to the time pod. Enter the coordinates for Galaxy Galleria. When you're back at the mall, travel to Radio Shock. Use the touch screen interface to communicate with the robot. Select the following categories:

- Catalog*
- Electronic Gadgets*
- Continue*



Press *Continue* until you find the PocketPal Connector. Push *Order*, then select the correct connector.

Travel back to the pod. Enter the coordinates for Xenon. Exit the pod. Walk two screens east. Before entering the Super Computer, for the second time click on the inventory icon and look at the pink rabbit. Remove the “lifelong” battery and place it in the PocketPal. Also attach the connector to the PocketPal. Click the hand cursor on the hint book. Turn to page 7 and find the question that begins

- I'm in a strange room inside the Super Computer...*

Use the pen on the fourth clue and you'll find a code. The game version I played displayed the following code:

❑ 69-65-84-76-69

Save the game. Enter the Super Computer. Plug the PocketPal computer into the nearest terminal and it'll display the location of the security droid. Avoid the droid at all costs. To get through the catwalk maze, begin at the tunnel door. Walk one screen north and one screen west. Travel down the left staircase. Wait for the droid to leave this screen. Travel up the staircase. Walk one screen east, one screen south, then west until you reach the Programming Chamber. To open the door, enter the code from the hint book. Walk into the computer room and you'll see a large blue screen. Click the cursor on the droid icon and drag it over the toilet. Click again to flush (terminate) that program. Now you're safe from the security droid. Do the same with the brain icon.

Hint: Don't flush the SQ4 icon. If you do, you'll return to the DOS prompt.

Click on the toilet to leave the computer scene. Save the game. To find Roger Jr. (starting from the Programming Chamber), walk three screens east, one screen north, and one screen west. Clamber down the staircase. Walk west until you reach the glass elevator. Travel to the third level. Walk one screen north, one screen east, then north.

Walk to the edge of the platform and a catwalk will appear. Cross the catwalk. Use the mouse button to fight Roger Jr. (Sludge Vohaul). When he's in the light, climb down the ladder, being careful not to fall off the edge. Upon your return, you'll have a diskette in inventory. Click the diskette on the disk drive. Push the following buttons to win the game:

- ❑ *Disk Upload*
- ❑ *Beam Upload*
- ❑ *Beam Download*

Congratulations! You've saved Roger Jr. from the evil Sludge Vohaul.

LOCATION OF OBJECTS

- ATM Card Galaxy Galleria
- Batteries Pink Rabbit
- Book of Matches Bar (Ulence Flats)
- Bubble Gum/Paper Police Officer (Estros)
- Cash ATM Machine (Galleria)
- Cigar Butt Walkway (Galleria)
- Diskette Sludge Vohaul
- Empty Jar Sanitation Office (Xenon)
- Hint Book Software Store (Galleria)
- Men's Clothing Big and Tall (Galleria)
- Pink Rabbit Old Bank (Xenon)
- PocketPal Adapter Radio Shock (Galleria)
- PocketPal Laptop Skimmer (Xenon)
- Rope Streets of Xenon
- Slime Sewer (Xenon)
- Women's Clothing Women's Clothing Store (Galleria)

MAPS

XENON

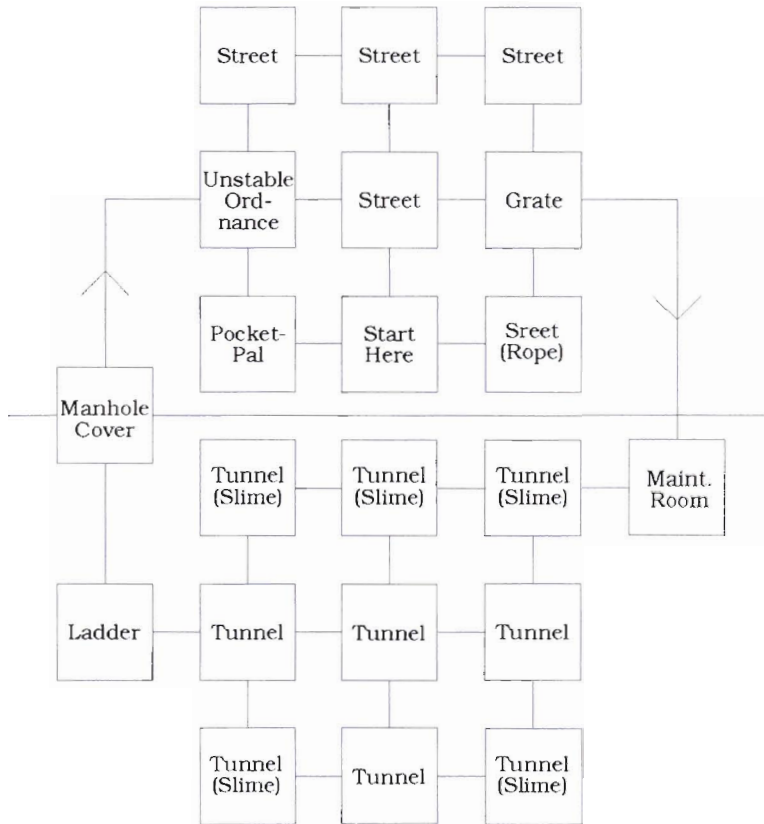

ESTROS BUTTES AREA

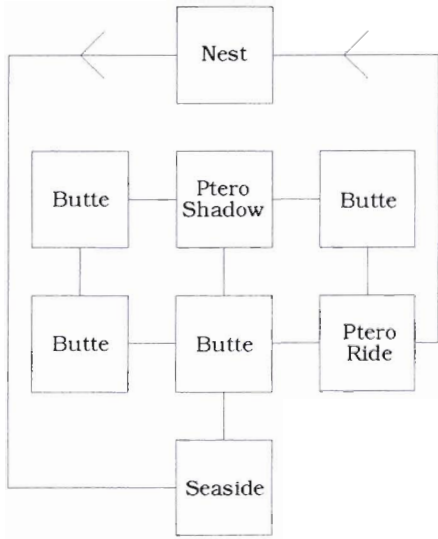

ULENCE FLATS

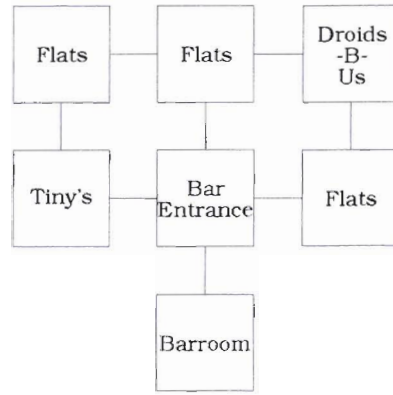

GALAXY GALLERIA MALL

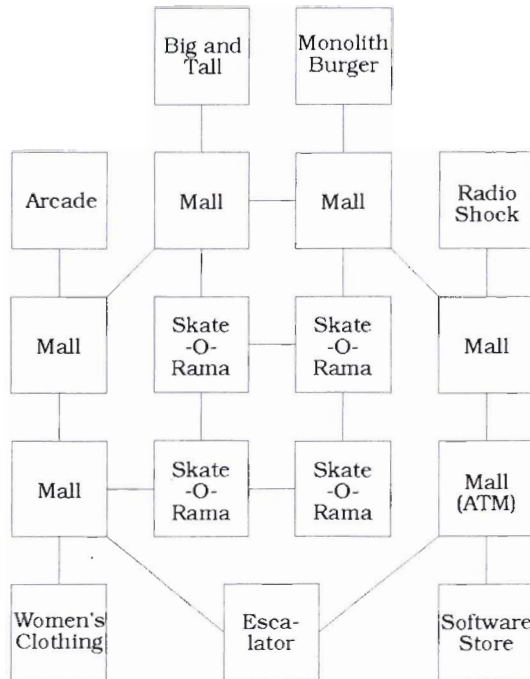

SUPER COMPUTER

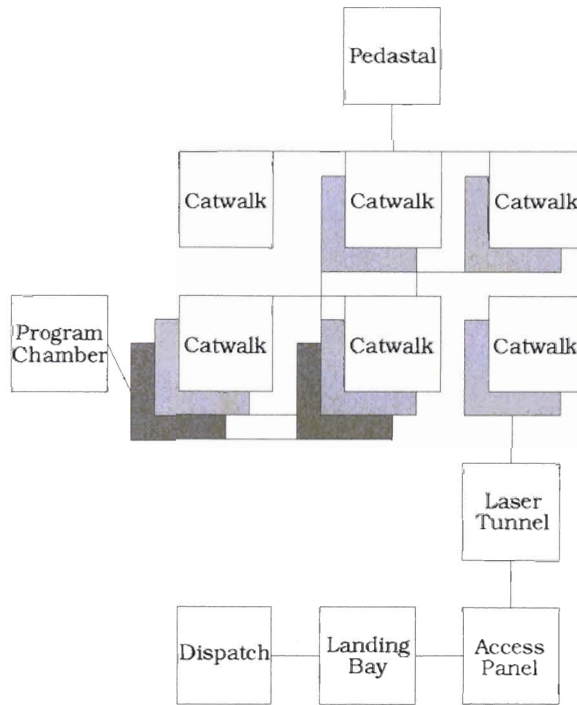

SECTION 2

SPACE QUEST V

GRAPHICS: ★★★

STORY LINE: ★★

ARCADE: ★★

INTERFACE: ★★★★★

DIALOGUE: ★★

AUDIO: ★★

ANIMATION: ★★★

LENGTH: ★★

OVERALL ANALYSIS: ★★★

SYSTEMS

- MS-DOS IBM-PC/Tandy & Compatibles
- Macintosh (May '93)

FEATURES

- Awesome 3-D animation, scintillating 256-color artwork, and Asteroids! Asteroids! Asteroids!*
- The smooth shrink-wrap packaging included at no charge with every game!*
- A breathtaking original score and digitized sounds so real you'll think you're on Xenon.*

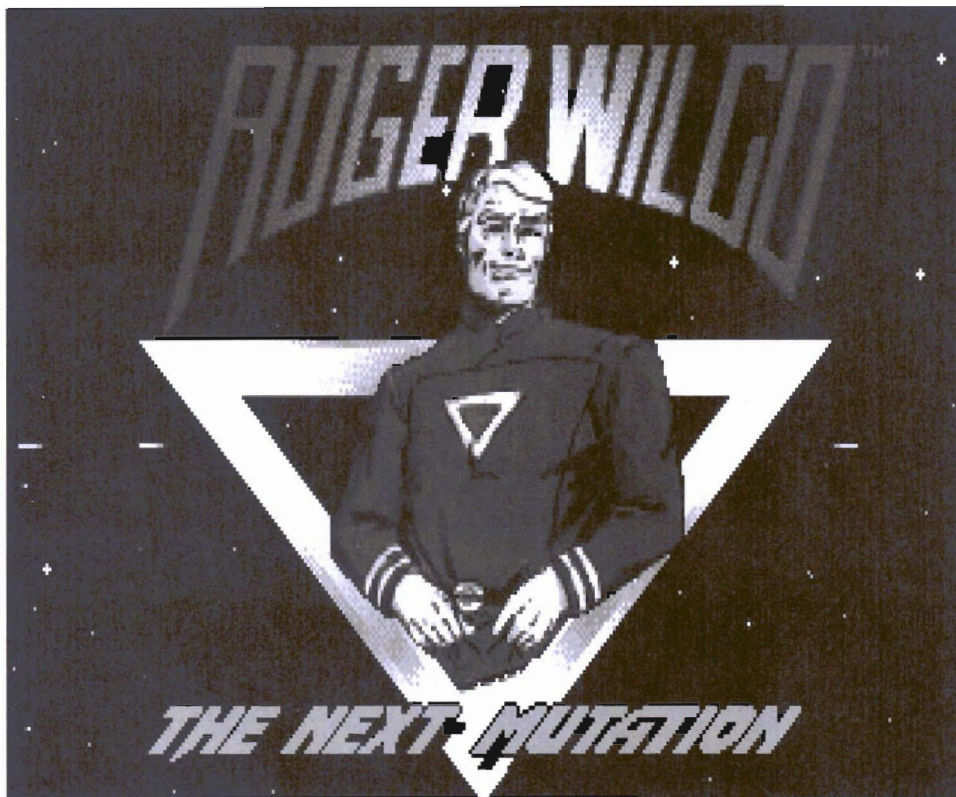

SCENARIO

Mark Crowe of Sierra On-Line soloed as the designer of this latest cosmic adventure, *Space Quest V: Roger Wilco, The Next Mutation*. As in the earlier chapters, you play the role of the universe's favorite janitor, Roger Wilco. After bamboozling your way through the StarCon Space Academy, you take control of your very own garbage scow (and for you trigger-happy hackers, yes, the scow has laser guns). Your goal is to sweep the universe clean of debris while seeking the antidote for the primordial soup that's turning the galaxy's inhabitants into a mutant menace. As you rampage through the cosmos, you'll deal with such inconveniences as an acid-piddling hugger, a metal witch with hooter-shooters, and a horde of grotesque mutants heinous enough to turn even the cool dude Rog into a slime-sucking sap-head.

WALK-THROUGH

STARCON SPACE ACADEMY

After the simulation, walk three screens south. Enter the classroom. Since Roger could never pass the StarCon Aptitude Test on his own, he decides to cheat:

❑ E-E-E-E-E-E-E-D-D-E

After class, walk one screen south. Open the broom closet and take the Scrub-O-Matic and the safety cones. To enter the rotunda, walk one screen south and one screen east. Walk onto the anti-gravity lift transport. Place the cones along the outer perimeter of the StarCon Crest. Click the Scrub-O-Matic on the StarCon Crest. Double-click the hand cursor on the Scrub-O-Matic. Guide the scrubber over the dirty portions of the Crest. When the Crest is completely clean, it'll sparkle and you'll hear a beep tone. Leave the rotunda. Walk one screen south and check the test results by clicking the eye cursor on the bulletin board.

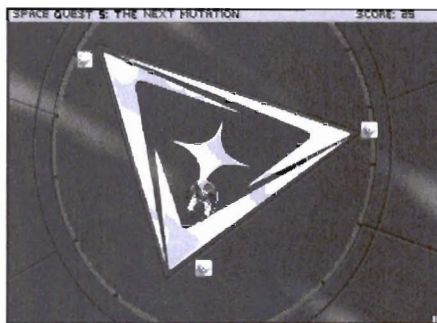

GANGULARIS

Have a seat in the Captain's chair. Command Flo to hail StarCon. Next command Droole to lay in a course. Enter the coordinates for Gangularis (you'll find the coordinates on pp. 17-18 of the *Galactic Inquirer* included with the game). Command Droole to travel at *lite speed*. When you reach your destination, command Droole to travel at *regular speed*.



Command Droole to *activate the RRS*. Exit the bridge by first clicking the hand cursor on the exit icon, then on the door behind the Captain's chair. From within

the engineering section of the *Eureka*, open the refuse compartment located along the east wall. Locate your chief engineer's tool box and take the following items:

- Laser cutting torch
- Spare fuse
- Hole punch
- Roll of anti-acid tablets



Enter the bridge by clicking the hand cursor on the north door. After Cliff contacts you via the intercom, exit the bridge and enter the engineering section of the *Eureka*. Reenter the bridge, sit in the Captain's chair, then enter the engineering section for the second time. Click the hand cursor on the west door leading to the transporter room, and walk around the room until the alien creature appears. Once Spike's in your inventory, place him and the anti-acid tablets in the Habitude (right side of screen). Walk to the bridge. I'll see you on planet Peeyu.

PEEYU

Lay in a course for Peeyu. Command Droole to travel at *lite speed*. When you arrive at your destination, command Droole to travel at *regular speed*. Also, if you haven't already done so, command Droole to *activate the RRS*.

KIZ URAZGUBI

After arriving at KU, you'll receive a disturbing message from a womanoid. To beam down to the planet, leave the bridge and enter the transporter room. Walk onto the teleport platform—located in the center of the room—and click the talk cursor on the computer along the north wall.

ESCAPE FROM THE ANNIHILATOR ANDROID

After beaming down to the planet, save the game. Then hustle beneath the waterfall and walk north. Walk one screen east and you'll reach a large, hollow log. Before crossing the chasm via the hollow log, walk north to the end of the tree limb. The limb will break and you'll tumble down to the beam site. Get the tree limb and retrace your steps back to the hollow log. Crawl through the log to

SPACE QUEST V

reach the other side. Use the stick to obtain a hanging fruit. Once you have the fruit, walk west (crossing the chasm), then southwest. Enter the center cave. Walk beneath the waterfall to reach the left cave entrance. Jump across the chasm onto the rock outcropping. Scale the cliff to reach the boulder. Use the stick to pry the



boulder loose. After the boulder strikes the Annihilator Android, retrace your steps to the bottom of the cliff (beam site). Then travel back to the hollow log. Hide inside the log until the metal witch appears. Throw the vaguely banana-like fruit at her. Crawl out of the log (west) and get the round metallic object (womanoid head). Return to the beam site and you'll automatically transport back aboard the *Eureka*. Well, Bucko, so far so good. Hang in there, buddy.

When you're back aboard the *Eureka*, leave the transporter room and you'll realize that you've forgotten to give Cliffy the womanoid's metal head. Therefore, reenter the transporter room and Cliffy will give you a left-over part from WD40, the Annihilator Android. Head back to the command post and talk to Droole (don't use the command icon). Ask him where to go for shore leave. Lay in the course for the Space Bar and, if I haven't had too much hooch (hick!), I'll see if I can help you once you get there.

THE SPACE BAR

What galaxy would be complete without a space bar? Not ours, that's for sure! Upon arriving at the Space Bar, enter standard orbit and beam on down. Save the game. Have a seat with your crew at the table along the west wall. While you're enjoying some R&R, a pushy salesman named Nelo Jones will approach you with a very annoying sales pitch. Give him the cold shoulder and he'll give you his business card

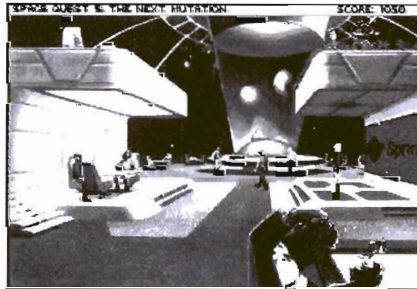

and a sample package of space monkeys. After the battleship-like arcade sequence and Cliffy's arrest, look at the business card and the package of space

monkeys. Have a seat at your table and place the space monkeys into your drink. This'll create a space monkey population explosion. Quickly walk onto the transporter platform (east side of screen) and get Spike from the Habitude. Beam back down to the Space Bar and walk one screen east. Wait for the guards to leave, then click the hand cursor on the control panel to shut off the force field. Walk north and locate Cliffy's holding cell. Click Spike on the cell bars and his acid droppings will melt through the thick metal bars.

KLOROX II

Welcome to Klorox II. Before being washed-up, save the game. Enter standard orbit and command Flo to hail the planet and StarCon. Depress the orange console button and command WD40 to scan the planet, scan for ships, and ask for her—er, *its* recommendation.

Hint: Don't press the red button—it activates the self-destruct sequence.

Beam down to the planet. Save the game. Enter the center building. Click on the small computer located in the center of the screen. When the mutant attacks, avoid his drool by tilting your head left and right. Plan to restore the game a few times until you get the hang of it. After escaping the grueling drool droppings, get the small piece of paper that the mutant dropped. Look at the paper and you'll find a code. Click the hand cursor on the computer and enter the code that was on the piece of paper:

❑ 80869

Walk back to the beam site, then walk one screen west (be sure to remain on the crest of the cliff). Look at the canister and you'll see the following coordinates:

❑ 41666

Walk back to the beam site and use the PCD (Personal Communication Device) to beam aboard the *Eureka*. Travel to the planet known as Thrakus.

THRAKUS

After arriving at Thrakus and entering standard orbit, contact WD40 (via the orange console button) and have her scan the planet, scan for ships, and offer her recommendations. Command Flo to hail the planet. Exit the bridge and activate the lift to the pod bay by pressing the red button (the button is located in the engineering department along the east wall). Step onto the lift. Take the oxygen tank from the cabinet behind the Star Roamer EVA Pod. Also, get the rebreather mask from the compartment located next to the pressure suits. Click the hand cursor on the pedestal control panel. Click on the orange button to open the elevator door. Enter the transporter room and walk onto the transporter platform. Click the rebreather mask on Roger and you'll automatically beam down to the planet.

Approach the space pod and click the hand cursor on its hull. Peer inside the pod and grab the frock. Click on the red flashing light. Walk one screen west and save the game. Now walk as far west as you can go. After being wrestled to the ground by Beatrice and almost losing your drawers, click the frock on Bea. Now quickly click the PCD on Roger. Wait for Beatrice



to toss you a vine. Climb the vine and you'll automatically beam aboard the *Eureka*. After you escape from the slime-sucking mutants, Beatrice will give you a distributor cap. Unfortunately, Bea was struck by one of their weapons and is now becoming a mutant herself. To heal her, find the red button (next to the Habitube) which releases the Cryo Chamber. Click the hand cursor on the Cryo Chamber to open it. Place Beatrice into the chamber, then look at the chamber. When you have a close-up view of Bea, click the eye cursor on the lower left portion of the screen. You should now see the controls. Click the eye cursor below the *Defrost* button to see the recipes and cooking times. Now, to Cryofreeze Beatrice, enter the number *10* and depress the *Start* button. This will place Beatrice in a state of hibernation. Head back to the command post and wait for the *Goliath*. When she spots you and actually dares to fire at you, command Droole to enter the asteroid field—it's your only escape.

CLIFFY'S RESCUE

Cliffy's got himself in another bind, and it's up to you, Bucko, to save him. But before saving Cliffy, you may want to save the game. Hustle to the pod bay. Rotate the pod using the appropriate switch on the pedestal console. Enter the pod. Save the game again.

Hint: Perform the following procedures rapidly.



Keep a close eye on your fuel and oxygen supply while maneuvering the pod toward the red dot on the radar screen (yup, that red dot is none other than Cliffy himself). Be sure to take it easy on the throttle, as it eats up fuel at an enormous rate. When you see Cliffy through the view port,

extend the mechanical arm. Maneuver the pod so that Cliffy's chest aligns with the claw of the extended arm. If the pod's in the correct position, a light will flash telling you that the target is within range. That's your cue to open the claw and grab Cliffy. Now close the claw and pilot the pod back to the *Eureka* (green dot). When you're back on the bridge, ask Droole what the chances are to get through this. Then enter the coordinates for KU.

THE CLOAKING DEVICE

After beaming down to KU, click the leftover part from WD40 on Roger to lower the anti-gravity lift of the cloaked spacecraft. Save the game, then walk onto the lift. Click the hand cursor on the panel located along the east wall. Open the top latch, then the bottom latch. Use the trial-and-error method to open the four outer panels by turning the knobs, then clicking on the panels (it's not that tough). Take

SPACE QUEST V

the cloaking device and vamoose. Enter the coordinates for the Genetix Research station (you found them on the soup can on Klorox II):

☐ 41666

GENETIX RESEARCH STATION

Enter standard orbit and have WD40 scan the planet. Then beam on down—just watch out for that fly in the transporter. After your genetic alteration (transforming you into a fly), buzz one screen west.

Hint: *Steer clear of the water and any Venus flytraps or Putrinias.*

Locate and fly through the electronic card key lock mechanism (left side of screen). Walk beneath the light beams and note which ones activate the hammers of the locking mechanism. Buzz into the Genetic Research Laboratory and land on the computer in the southeast corner of the room. Select *Systems*, then walk on *Envirodome 3*. Click the button labeled *Security*, then initiate all three camera views. Before leaving the computer, click on the remaining choices available on the main menu.

Buzz through the key card mechanism, then fly one screen east (stay away from Cliffy—he'll squash you like a, well, bug). Buzz over the communicator until a frog leaps out of the water. Land on the communicator and depress the red button. Talk to Flo and she'll relay your condition to Cliffy. Now it's safe to land on your chief engineer and *bug* him about his little mistake. After conversing with Cliffy, fly one screen north and you'll reach the trash bin. Click the fly cursor on Roger's body and Cliffy will change him back to normal. Follow Cliffy to the hidden doorway (next to the key card slot). Use the hole punch to punch five holes into the business card (you did take the hole punch from Cliffy's toolbox as I suggested earlier, didn't you?). Punch four holes in the outer perimeter of the card, and one in the center. You must align the punch precisely within the squares—otherwise you won't leave a hole.

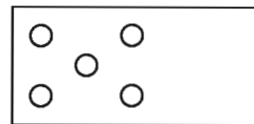

Enter the lab and open the panel along the north wall (below the large monitor). Take the liquid nitrogen canisters. Leave the lab. Beam aboard the *Eureka*. After Spike goes crazy, click on the last dialogue response. Look at the Cryo Chamber, then at the control panel. Enter the number *10* to *Defrost* the Ambassador. Open the chamber and place Beatrice onto the transporter. Now talk to WD40, then enter the bridge. Talk to Droole and to Flo. Enter the coordinates for Gingivitis.

THE *GOLIATH*

As you approach Gingivitis, WD40 will scan the area and spot the *Goliath* (gulp). Contact Cliffy via the green console button, and have him cloak the ship. Leave the bridge and enter the transporter room (lab). Use the eye cursor on the holographic image of the *Goliath* to locate a safe point of entry. Before using the pod to reach the *Goliath*, be sure to have the laser cutting torch in inventory (it's in Cliffy's toolbox). When you reach the *Goliath*, click the hand cursor on the

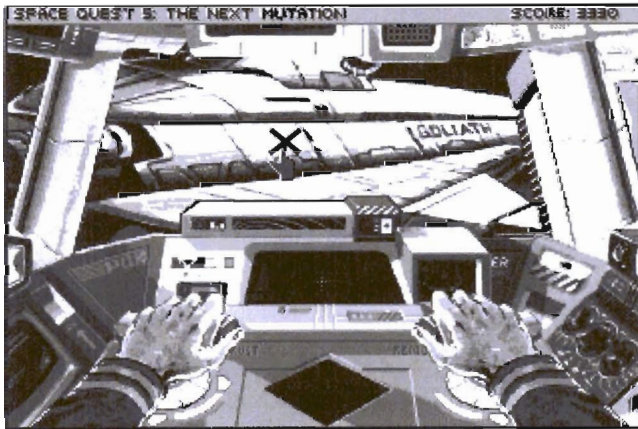

section of the hull that's below the talk icon of the menu bar and in line with the stenciled name *Goliath* (at the *X* on the illustration). Open the door of the EVA pod and use the laser cutting torch to gain entry into the *Goliath*. Now save the game, then hustle to the center control panel

before the mutant appears (the mutant won't see you as long as you're near the control panel). Click the hand cursor on the control panel. Click the eye cursor on the device until a window appears stating that this must be the place where Beatrice liberated the distributor cap. Place the distributor cap onto the base of the drive unit. Save the game. Wait for the mutant guard to make his rounds in the drive bay, then you can exit through the north doorway. Click the hand cursor on the grate to enter the maintenance tunnels. Your objective is to reach Level 2 and find the switch that turns off the *Goliath*'s shields. Use the following path while saving the game *before* entering the elevator shafts:

SPACE QUEST V

- ❑ Level 8: North, East, North, North
- ❑ Level 6: South, West, North, North, East, North, North
- ❑ Level 4: South, West, North, West, North, West, North, North
- ❑ Level 2: South, South, West, South, East, South

Flip the switch to turn off the shields and you'll be captured by Quirk—way to go, Bucko. Wait until all the mutants are on the transporter pad and the doors have closed. Then click the talk cursor on Cliffy. Use response No. 1 with Flo and command Droole to fire the lasers at the Quirkoid Blob. Now command Droole

to activate the RRS. Engage the self-destruct sequence by pressing the red button, then clicking the hand cursor on the egg. Dart into the transporter room and free Beatrice from the chamber. Attempt to transport to the *Goliath* and the machine will blow a fuse. Enter the engineering section of the *Eureka*, then climb into the service tunnel located along the east wall. Remove the fuse labeled in red and replace it with the fuse you took from Cliffy's toolbox. Jump over the blob into the transporter room and beam on outta there—oh, and Rog: Don't forget Spike.

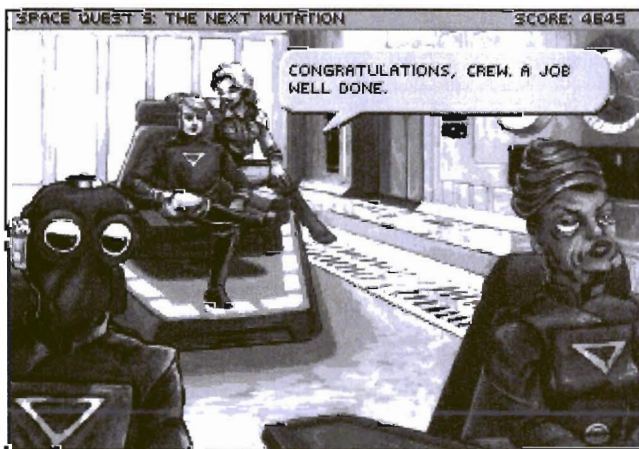
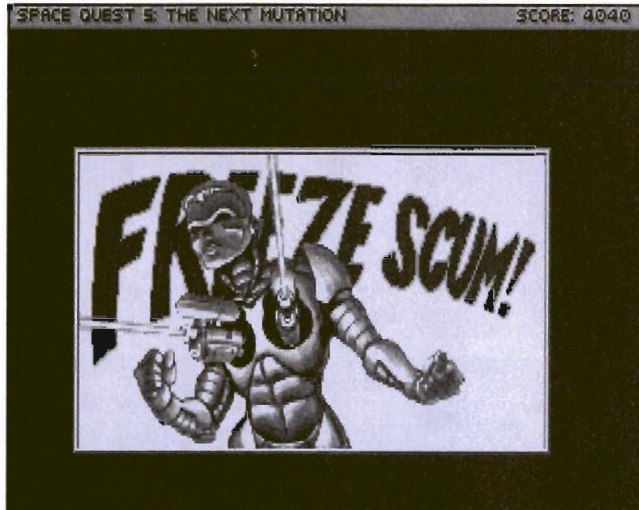

LOCATION OF OBJECTS

- Alcoholic Beverage Space Bar
- Anti-acid Tablets Cliffy's Toolbox (*Eureka*)
- Banana-like Fruit Kiz Urazgubi
- Business Card Nelo Jones (Space Bar)
- Cloaking Device WD40's Spacecraft (KU)
- Coordinates for Genetix Soup Can (Klorox II)
- Distributor Cap Beatrice (*Eureka*)
- Frock Escape Pod (Thrakus)
- Hole Punch Cliffy's Toolbox (*Eureka*)
- Laser Cutting Torch Cliffy's Toolbox (*Eureka*)
- Left-over Part From WD40 From Cliffy (*Eureka*)
- Liquid Nitrogen Lab (Genetix)
- Oxygen Tank Pod Bay (*Eureka*)
- Piece of Paper Klorox II
- Rebreather Mask Pod Bay (*Eureka*)
- Safety Cones Broom Closet (StarCon Academy)
- Scrub-O-Matic Broom Closet (StarCon Academy)
- Space Monkeys Nelo Jones (Space Bar)
- Spare Fuse Cliffy's Toolbox (*Eureka*)
- Spike Refuse Compartment (*Eureka*)
- Tree Limb Kiz Urazgubi
- Womanoid Head Kiz Urazgubi

MAPS

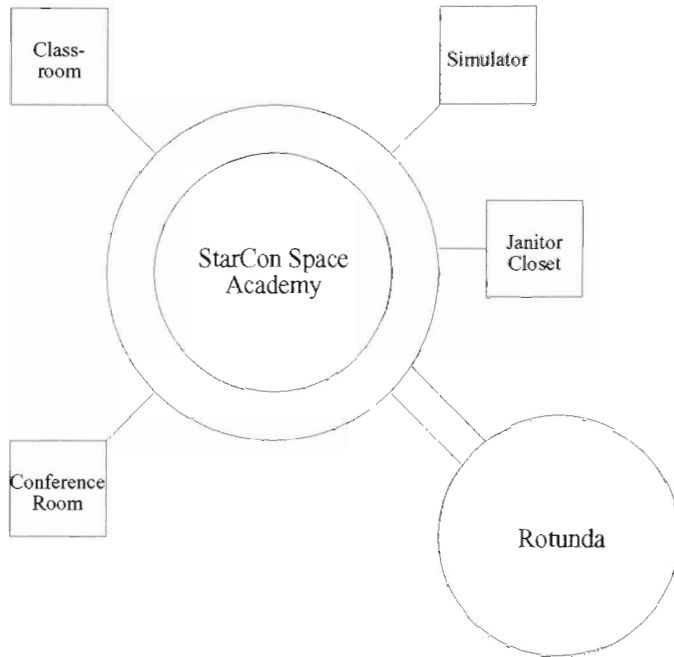

EUREKA

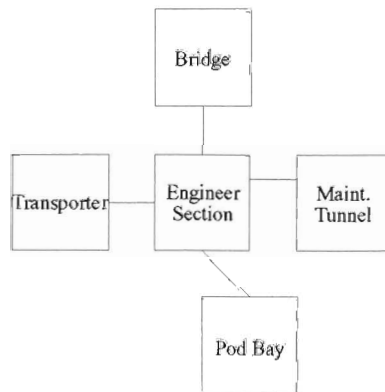

CHAPTER 9

WILLY BEAMISH

GRAPHICS: ★★★

STORY LINE: ★★

ARCADE: ★

INTERFACE: ★★★★★

DIALOGUE: ★★

AUDIO: ★★

ANIMATION: ★★★★★

LENGTH: ★★★★★

OVERALL ANALYSIS: ★★★★★

SYSTEMS

- MS-DOS IBM-PC/Tandy & Compatibles
- Amiga
- Macintosh
- Sega CD-ROM

FEATURES

- A seriously mental cast of characters.*
- An easy-to-use point-and-click interface.*
- Traditional cell animation.*
- Hand-painted backgrounds.*
- Truly wicked puzzles and an outrageous original soundtrack.*



SCENARIO

Your name is Willy Beamish and you're a trouble-making nine-year-old facing neurotic yuppie parents, a baby-sitter from hell, a ghostly grandfather watching your every move, and—worst of all—a tag-along little sister. Your avocation is to get enough practice so you can win the Nintari Championship. And, speaking of contests, wouldn't it be great if your pet frog Horny finally beat Turbofrog in the frog-jumping contest!?

Jeff Tunnell (creator of *Heart of China* and *Rise of the Dragon*) brings together animation talents from *The Simpsons*, *Johnny Quest*, and *The Little Mermaid* to create a seriously warped adventure that took more than 40 cartoonists and animators to create. Since this game targets youngsters (or, in my case, the young at heart) the interface must be a simple one. And it is—the cursor will automatically change when placed over an object of importance. No more cycling through cursors with this interface! The installation procedure is completely effortless because Dynamix included a program called *Smart Start*. This program automatically determines your system's graphic capabilities, sound board type (if any), input device(s), and the speed of your machine. A word of advice: While playing the role of Willy, you may have an indignant urge to be rude to those who treat you bad (and I don't blame you). But you must stifle your temperament and remain cordial—if the Trouble Meter boils to a dangerously high level, pack your bags for Military School, dude!

WALK-THROUGH

DAY 1: CARBUNCLE SCHOOL

The game begins in English class. When Ms. Glass (the ancient teacher) asks Willy a question, use the following responses:

❑ 2-3

While Ms. Glass is writing something on the blackboard, move the cursor over Willy's desk (the cursor will change into a solid red arrow) and click the mouse button. Inside the desk you'll find some very useful items.

Being the cool dude that you are, you quickly devise a plan to get out of class. First use the white crayon on the ringed block of wood. Then place both crayons and the hall pass in inventory. When Ms. Glass falls asleep, vamoose. Sneak through the east doorway and tip-toe to the bathroom. When Coach Beltz stops you, use response No. 1, then show him the fake hall pass. Enter the bathroom and you'll meet Spider, the school bully (yikes!). To avoid getting your head bashed in, give Spider the GameBuddy from inventory (backpack).

THE BEAMISH HOME

Question: *You're standing at the front door of the Beamish home and you see your report card in the mail slot: Should you take the report card and hide it from your parents, or should you leave it be?*

Answer: *If you want to see the inside of a military school, then by all means take the report card. Otherwise, leave it be.*

Enter the house. Duffy, your mutt . . . I mean dog, will be begging you to take him for a walk. What a pain in the butt this fleabag is. Oh well—deal with him by choosing response No. 1. Upon your return, check the answering machine for any incriminating messages (be sure to click on it more than once). From the foyer, walk north into the kitchen. Talk to Sheila using response No. 1. The next scene will be of the backyard. While pushing Brianna on the swing, don't send her

THE ADVENTURES OF WILLY BEAMISH

to the moon: Instead choose response No. 2. The next scene will take place in the kitchen: Sheila will ask you to slice some vegetables. Don't cut your thumb! If you do, don't cuss—zip your lips and hustle to the upstairs bathroom (being careful not to get any blood stains on Mom's carpeting). Open the medicine cabinet. Retrieve the first-aid kit and open it. I know iodine stings, but you don't want an infection, do you? Apply the iodine, then place the bandage over the wound.

While you're upstairs, enter Willy's bedroom and get the jar of flies (Horny loves to eat flies). Click on the deluxe Nintari game. After the game, explore the Beamish home until Sheila calls you to dinner. Hustle to the dining room. If you take too much time getting there (after Sheila has called you) the Trouble Meter will rise to a dangerously high level.

During dinner, Gordon will read your (not so good) report card. For punishment, he'll give your Nintari key to Tiffany for safe keeping. Without this key, you can't practice Nintari. Before getting the key back, you'll need to do a few things first: After feeding the dog, leave the dining room. Enter the living room by walking west. Talk to Gordon and he'll ask you to mow the lawn. Agree to his request—you need the money. After completing the chore, go upstairs and enter Tiffany's room. Snatch her diary from the dresser. Now bribe her by clicking the diary on Tiffany. Use response No. 1. She'll trade you the Nintari key for the diary.

Note: Sometime during the previous sequences, Sheila will ask you to get the conditioner for Tiffany. Agree to her request by entering the bathroom and tossing Tiffany the red bottle located on the counter. Just don't touch the Nintari key!

Exit Tiffany's bedroom and enter Brianna's bedroom (it's located across from Willy's). Help Brianna and the Trouble Meter will decline slightly. Enter Willy's bedroom and click the key on the Nintari game. You must play at least one game to win the tournament. When the Nintari game is over, enter the attic and engineer Gordon's train set. DO NOT crash the trains.

Soon Sheila will tell you it's bedtime. Don't delay unless you want the Trouble Meter to rise. Once you're in bed, Day 1 will end.

DAY 2: THE TREE FORT

Begin the new day by feeding Brianna and Duffy. Now you'll need to earn some more money. Agree to wash Gordon's truck. After washing the truck, check the answering machine for messages.

Leave the Beamish home and travel to the tree fort (it's located on the left side of the neighborhood). Get the magazine and place it in inventory. Talk to Perry, then to Dana. Choose response No. 2. When she asks if you want to get a pizza, move the cursor to the left side of the tree fort (an *EXIT* sign will appear). Click the mouse button to leave the tree fort.

THE PIZZERIA

Once you're inside the pizzeria, a photographer will ask if you'd like a photograph taken of you and your two friends. Agree to his request by choosing response No. 2.

A bad habit of Willy's is to relieve some pressure in a public place, then to deny it. Well, the pizzeria is no exception. When Spider gets a whiff of Willy, choose response No. 1. While in the bathroom, take the *No Smoking* sign. When Spider appears, give him the magazine (which you found in the tree fort). After the explosion, you'll automatically arrive at the tree fort. Talk to Dana, then leave the fort. When you arrive at the frog-jumping practice grid, get Horny from your backpack and place him on the grid. To make him jump, click the cursor on him. Feed Horny some flies and maybe he'll jump farther. If that doesn't work, buy some Slam Dunk Cola from the vendor and give Horny a swig.

THE FERRY TOKEN AND THE T-SHIRT

Travel to East Frumpton (top-right of the screen), then go to Olde Towne. Walk to the fountain and take only ONE (1) ferry token. If you take more than one, the police officer (who's watching you closely) won't like it and will send you to that school with the funny name. After you have the ferry token, travel to OK T-Shirt Kiosk. Look at the lottery machine and press the coin return. Get the lottery ticket, then talk to Roof Westenheimer, the clerk of OK T-Shirt Kiosk. Give her the photograph and she'll transfer the picture onto a T-shirt. Once you're back at the Beamish home, travel throughout the house until Sheila calls you to the foyer to meet the baby-sitter from hell. **SAVE THE GAME!**

THE BABY-SITTER FROM HELL

After being introduced to the baby-sitter from hell, save the game. Then follow her into the kitchen and ask if dinner is ready. Walk into the dining room. To your horror, the macaroni that you're eating isn't pasta at all, but rather slimy little worms . . . yuck!

Brianna will throw her plate at the baby-sitter, making the sitter mad enough to change into an evil bat (how did she do that?). Since this puzzle must be solved in a certain amount of time, save the game again. To defeat the baby-sitter from hell, begin by running upstairs. Enter Brianna's bedroom. Take the mouse from the cat. Dart back downstairs and enter the living room. Hide behind the couch, then throw the mouse on the coffee table. When the bat lands on the mouse, click the right mouse button until you see the cross hairs. Place the crosshairs over the bat and click the left mouse button.

After defeating the baby-sitter from hell, you'll awaken to realize it was only a nightmare. What a way to end Day 2 ...

DAY 3: WEST FRUMPTON

Begin Day 3 by taking Duffy for a walk. Leave the Beamish home and see if any of your buddies are at the tree fort. If Dana and Perry are there, talk to Perry. He'll tell you about the fire ants. Get the jar of fire ants and place it in inventory.

To convince Dana to enter the frog-jumping contest, give her the T-shirt you purchased at OK T-Shirt Kiosk. After she agrees, you'll automatically travel to the frog-jumping practice area. Leave the practice area and travel to East Frumpton. Walk to the fountain and you should see Tiffany (as you never have seen her before). Get on the ferry by giving the guard the token. Travel to Tootsweet Corporation and get an entry blank for the frog-jumping contest.

Since the ferry's stuck on a sludge bar (leaving you stranded in West Frumpton), you have time to familiarize yourself with the city. You can go to the Golden Bowl Bar, the Plumber's Union Local 409, and the Sludge Works.

THE GANG

At 19:00 hours (you can check, *and change*, the time by clicking on the inventory window) travel to the Golden Bowl. There you'll encounter a rival gang. You

must move very fast to escape this gang. First, throw the smoke bomb (which you received from the Chinese tourists) at the gang—this'll slow them down. Second, using the wrench Ray gave you, open the fire hydrant and douse the gang. Now run for your life! Hustle to the Tootsweet building and you'll find the Chinese tourists. Talk to them using response No. 1. Since the Chinese tourists are actually Ninjas in disguise—and you were kind enough to take their picture earlier in the game—they'll help you defeat the rival gang.

DAY 4: THE FROG-JUMPING CONTEST

Travel to the tree fort. Talk to Dana. Travel to East Frumpton, then Olde Towne. Get on the ferry. Travel to Tootsweet. Before giving the judge the entry form, place the jar of flies in front of Turbofrog. He'll eat them and get very tired. This will help Horny win the contest. **DO NOT** give Horny any Slam Dunk Cola. If you do, you'll be disqualified from the competition. Save the game. Give the judge the entry form. After the contest, Horny will hop into the Tootsweet building. You'd better follow him before he gets lost. Unfortunately, the security guard busts you. To escape from the guard, click on the inventory window and combine the Nintari key with the chain. Click the key/chain assembly on the security guard to hypnotize him. The correct hypnotic phrase can be found in the game documentation under the article entitled



Dr. Jeckle's at Home Hypnosis Course

When the security guard's under your spell, split.

THE GOLDEN BOWL BAR

To get inside the Golden Bowl, you'll need to distract Ray, the bouncer. To do this, go back to the dock and climb on your new jet-ski. Before taking it for a spin, however, click the right mouse button until you have the magnifying glass cursor. Click the magnifying glass on the jet-ski and get the radio/cassette

THE ADVENTURES OF WILLY BEAMISH

recorder from the dashboard. Now travel to the Plumber's Union. Do you see the window that's slightly ajar? It leads to Louis's office. Open the window and enter the office. Suddenly, Louis will come barging in. Grab the plunger and throw it in Louis's face. This'll give you just enough time to get the security pass from the desk and flee the office.

Enter the phone booth. Get the cassette recorder from inventory and place it on the shelf beneath the phone. Place the phone receiver atop the tape recorder and push the *Record* button. Call Alyssa by dialing the following number:

❑ 432-7446

After recording Alyssa's message, dial the Golden Bowl:

❑ 342-3403

When you get Ray on the phone, push the button labeled *Playback* and the recorder will play Alyssa's message. This'll distract Ray, allowing you to enter the Golden Bowl bar. Unfortunately, the bartender doesn't want minors in his establishment. To get on Burt's good side, give him the lottery ticket and he'll allow you to stay awhile. Before leaving the Golden Bowl, grab a nudie calendar from the bar. Use your jet-ski to travel to Humpford Mansion.

HUMPFORD MANSION

Welcome to Humpford Mansion, the home of Leona and Louis. In the foyer you'll meet Arthur, the parrot. To get past Arthur, you must be very careful what you say to him. If you ruffle his feathers, he'll squawk very loudly—informing Leona and Louis of your presence. Try using the following responses when conversing with Arthur:

❑ 1-2-1-2

Enter the dining room by walking east. Take the bronze chalice from the table and place it in inventory. Now take the quilted table cloth. Click the magnifying glass



cursor on Leona and Louis, who are in the next room, and listen to their conversation (don't enter the living room). Go back to the foyer and place the tablecloth beneath the suit of armor. Click on the armor and it'll collapse onto the table cloth. Get the helmet and the map. Save the game.

THE FROG CONVEYER

To save the frogs, throw the bronze chalice at Chef Childish. Quickly sneak into the kitchen and grab the skillet from the stove. Pour the hot butter on the floor directly behind Chef Childish. Slide the large kettle closer to the chef, then go back to the entranceway of the kitchen. Jump onto the frog conveyer and it'll swing you around the kitchen, dropping you directly in front of Chef Childish. Shocked by your presence, Chef Childish will slip on the hot butter and land in the kettle. Stifle her screams by placing the helmet over her head.

To free the frogs, push the right button located on the conveyer control panel. When you leave the kitchen, you'll be caught by Leona and Louis. Fortunately, the frogs will free you from the underwater torture chest. Now get on your new jet-ski and skim the waves as you travel to West Frumpton.

FRUMPTON SLUDGE WORKS

To get past the striking union workers, give them what they like best—the nudie calendar. Give the security guard the security pass. Although Frank will allow you to pass the security office, his better judgement forces him to sound the alarm—so you must move very quickly.

Once inside the plant, run down the catwalk by clicking on the control panel. To operate the catwalk, use the control panel. The correct color combination can be found in the corner of the blueprint you found in the suit of armor. The procedure to operate the catwalk follows:

- Lift the cover of the on/off switch.
- Turn on the controls.
- Push the brown button.
- Push the pink button.
- Push the green button.
- Push the pink button.

THE ADVENTURES OF WILLY BEAMISH

Once you have the green light, and the guards are crossing the catwalk, flip the long lever. This will cause the left catwalk to retract and the right catwalk to extend. Exit this scene by traveling east. At the end of the catwalk, you'll find yet another control panel. To operate this panel, flip the lever to the *ON* position. Then type in the word:

❑ *AIR*

When the guards appear, press *ENTER* and they'll be blown off the catwalk. Type in the following word and press *ENTER*:

❑ *TRAM*

When you find yourself on a moving conveyor, wait until Stanley throws his hat at you—then duck. Get his hat from the end of the conveyor and click the right mouse until the cursor changes into crosshairs. Carefully align the crosshairs over Stanley and click the left mouse button to throw the hat at him. If your aim is that of a sharpshooter, you'll knock Stanley unconscious. After he falls off the end of the conveyor, jump onto the red piston. Enter the tram car.

You can get through the tunnels one of two ways—by using the blueprint you found in the suit of armor, or by following my instructions. If you've chosen to follow my instructions, begin at *Grand Junction* and go straight ahead until you reach *Conjunction Junction*. Turn right. When you reach *Compunction Junction* take a left. Go forward until you reach *Petticoat Junction*, then turn left.

To free Gordon from the giant sludge toilet, click the Yo-Yo on Willy. Next click the right mouse button to change the cursor into crosshairs. When Leona and Louis begin laughing at you, throw the Yo-Yo at them. If your aim and timing are perfect, they'll fall into the giant toilet bowl. Oh, and Willy—don't forget to flush!

LOCATION OF OBJECTS

- Bandage First-aid Kit (Bathroom)
- Bronze Chalice Dining Room (Humpford Mansion)
- Cassette Recorder Jet-ski
- Crayons Willy's Desk (Carbuncle School)
- Diary Tiffany's Bedroom
- Entry Form Tootsweet Corporation
- Ferry Token Fountain (Olde Town)
- Hall Pass Willy's Desk (Carbuncle School)
- Helmet Suit of armor (Humpford Mansion)
- Iodine First-aid Kit (bathroom)
- Jar of Fire Ants Tree Fort
- Jar of Flies Willy's Bedroom
- Jet-ski First Prize (Frog-jumping Contest)
- Lottery Ticket Lottery Machine (Olde Town)
- Magazine Tree Fort
- Map Suit of Armor (Humpford Mansion)
- Money Performing Gordon's Chores
- Mouse Brianna's Bedroom
- Nintari Key Tiffany
- No Smoking Sign Bathroom (Pizzeria)
- Nudie Calendar Golden Bowl Bar
- Photograph Pizzeria
- Quilted Table Cloth Dining Room (Humpford Mansion)
- Security Pass Louis's Office (Plumbers' Union)
- Slam Dunk Cola Vendor (Frog-jumping Grid)
- Smoke Bomb Chinese Tourists (West Frumpton)
- T-shirt OK T-Shirt Kiosk (Olde Town)
- Wrench Golden Bowl Bar (Ray the Bouncer)

MAPS

BEAMISH HOME

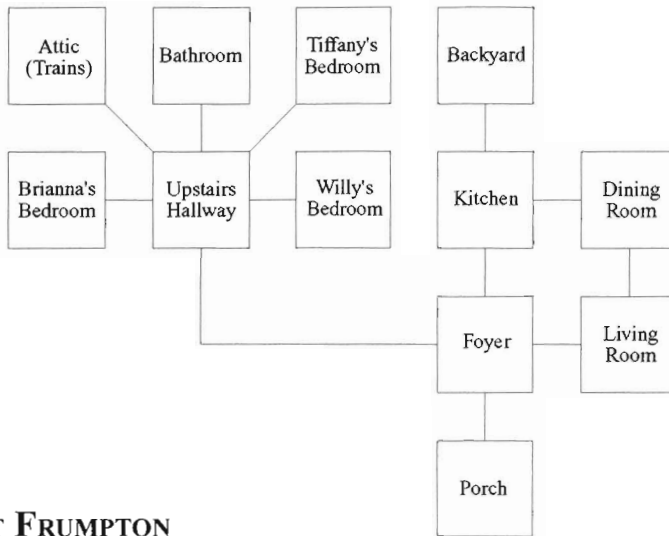

EAST FRUMPTON

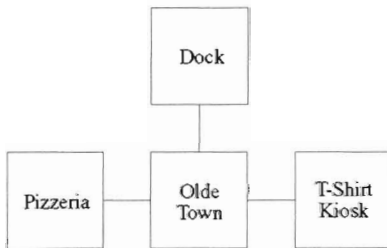

WEST FRUMPTON

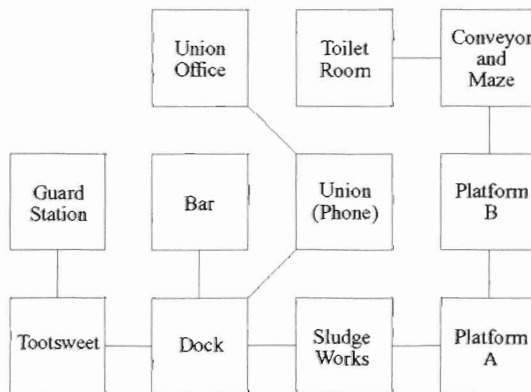

CHAPTER 10

DARK SEED

GRAPHICS:	☆☆☆☆	STORY LINE:	☆☆☆☆
ARCADE:	N/A	INTERFACE:	☆☆☆☆
DIALOGUE:	☆☆	AUDIO:	☆☆☆
ANIMATION:	☆☆☆	LENGTH:	☆☆☆☆

OVERALL ANALYSIS: ☆☆☆☆

SYSTEMS

- MS-DOS IBM-PC/Tandy & Compatibles
- Amiga
- Atari

FEATURES

- Stunning full-color, high-resolution graphics.*
- Hauntingly realistic voices and sound effects.*
- Movie-like storyline with twists.*
- No typing—easy point-and-click.*
- Exciting real-time animation.*
- Explore more than 75 locations.*
- Original soundtrack.*
- Terrifying nightmare sequences.*



SCENARIO

A mind-blowing, ingenious masterpiece—a medley of art and animation! *Dark Seed* by Cyberdreams is a hallucinatory adventure weaving you in and out of reality. Combining a sophisticated storyline with vivid digitized graphics gives *Dark Seed* instant prominence in the computer gaming industry. To fully appreciate this game, you should be aware of its technical background: *Dark Seed* incorporates the stygian artwork of H.R. Giger. Giger’s work brilliantly synthesizes humans and machines (or should that be machines with humans?). Fans of Emerson, Lake and Palmer and Danzig will recognize Giger’s work from album covers he painted for their *Brain Salad Surgery* and *Danzig II: Lucifuge*, respectively. Giger, an Academy Award winner, also painted the creature that stirred many a nightmare—that creature was, of course, the *Alien*.

Dark Seed took more than six “man years” to create, plus an astounding investment of more than \$500,000. As a result, you can expect a superior game that uses digitized speech and actual video of live actors—the characterization’s among the best I’ve seen in both proportion and gesticulation.

Enough technical mumbo-jumbo—let’s focus on the story itself. You play the role of Mike Dawson (which, ironically, is the name of the person who designed the game—programmer’s prerogative, I guess). As Mike Dawson, you’ll encounter two worlds:

- ❑ The real world
- ❑ The dark world, or “dark side”

The real world includes Mike’s sanity, his large house, a creepy cemetery, and a town complete with a library, Sheriff’s office, Barber shop, and general store. The dark world is somewhat similar to the real world except it uses Giger’s futuristic landscapes, which really make your hair stand on end. Prepare to travel back and forth between these two worlds as you try to destroy the mystical dark side. Although the media seems to have had a difficult time putting a stamp on this game, you really should leave the judging to yourself.

Thumbs-up to Giger and the entire Cyberdreams team for bringing this masterpiece to life. Let’s all encourage them to release a sequel—or two!

BEFORE YOU BEGIN

This is a very elaborate science-fiction game that should only be tackled by an experienced adventurer. If you're a novice, I strongly suggest trying a few easier games before entering *Dark Seed*. There are two major reasons why this game's so difficult.

First, you're on a very strict time limit: If you don't complete all the tasks required to complete the game in the time available, you'll die after the third day.

Second, if you forget (or simply can't find) an object early in the game, the game will continue—without giving you any type of warning that you may have missed something.

Without having this manual nearby, plan on spending many hours—even weeks—trying to complete *Dark Seed*.

Hint: The game clock is sometimes difficult to read. When checking the time, don't confuse a three for a five, or vice-versa.



WALK-THROUGH

DAY 1

After Mike's rude awakening, he'll have a splitting headache. To relieve the pain, enter the bathroom by walking through the right doorway. Get a handful of aspirin from the medicine cabinet. Take a shower.

***Hint:** Don't bother looking under all the rugs, behind all the paintings, and within all the cabinets—you won't find a thing!*

Enter the guest bedroom. Locate the trench coat. Click the exclamation cursor on it twice. When you see a bulge, get the library card. To look at the library card, click the question-mark cursor on the appropriate icon. The card belongs to the book entitled

The Lord of the Rings

Leave the guest bedroom by walking through the center doorway. Since there's a strict time limit in this game, it would be quite helpful if you were carrying a watch. The watch is hidden in the attic. Enter the attic by climbing the ladder from the upstairs hallway. Click the hand cursor (several times) on the handle of the gray trunk. After moving the trunk as far as it will go, get the watch. Wind the watch.

Leave the attic and wait for the doorbell: It'll ring at 10 o'clock sharp. Answer the door and look inside the package. Walk one screen west to enter the study. You'll find two things in the study:

- A blueprint
- A secret passageway

Get the blueprint. Look at the blueprint. Notice the secret passageway leading

DARK SEED

from the study to the bedroom. To access this passageway, click the hand cursor on the east wall. Enter the secret passageway. OPEN THE PASSAGEWAY DOOR.

Hint: You must keep both secret passage doors open during the entire game—this is extremely important.

Climb the ladder. Get the rope. OPEN THE PASSAGEWAY DOOR. Leave the bedroom through the doorway nearest the bed. Travel to the attic. Walk onto the balcony and click the rope on the gargoyle. Climb down the rope. Enter the garage. Get the crowbar from the vehicle's trunk and the gardening gloves from (where else but?) the glove box. Try the radio and the horn.

Leave the garage. Climb up the rope. Enter the attic. Pry open the gray trunk with the crowbar. Get the old diary. Read the diary. Go downstairs and enter the living room. Look at the large mirror—note the sign. You may also investigate the kitchen and the wine cellar, but you won't find anything there this early in the game. In fact, the kitchen holds no clues at all. Leave the house via the front door. Read the newspaper. Walk east to reach town.

Welcome to Woodland Hills, a small, quiet town where all the shops (including the police department) close precisely at six o'clock. Enter Klug's Food Market and give the clerk some money. Click the hand cursor on the cheap bottle of Scotch located near the rear of the store. Besides a couple of bottles of Scotch (you'll need to purchase another bottle later in the game), there's nothing else you'll need from this store. After purchasing the bottle of Scotch, Delbert will appear and introduce himself. He'll give you his business card and ask you to meet him tomorrow. Look at the business card. Leave the store and walk east.

Forget about the Barber Shop—you'll never get inside. Continue walking east. Enter the library. Click the library card on Sue (the librarian). The book you're looking for has a green binding and is located in aisle C. Walk through the north doorway. Enter aisle C. Get the note from the green book. Read the note. The last complete sentence contains the code to open the mausoleum. Before leaving the library, get the bobby-pin located on the floor in front of the librarian's desk—you never know when a lock will need picking. Travel back

to the house. If it's still early in the day (before 6 p.m.), you can visit the cemetery by walking west. Enter the cemetery and find the mausoleum. To open the door, press the sigils in the following order:

❑ Left-Top-Right

Find Joe Tuttle's urn. Get the clock key from the urn. Leave the cemetery and head on home.

Note: If you run out of time on the first day, you can complete most of these tasks on Day 2.

Enter the house. If the phone's ringing, answer it (the only phone in the house is located upstairs in the master bedroom). If it isn't too late in the day, you can travel back to the library.

To get the book (which was put on reserve for you), click the hand cursor on Sue, the librarian. The message in the book will refer to the car's radio. Travel to the house. Use the key on the clock and you'll find the name

❑ *John McKeekan*

You'll need to dig up the grave with this name on the second day of the game. Check the time: If it's before 10 p.m., feel free to roam throughout the house. If you wish to go to sleep early, you can do so by clicking the hand cursor on the bed, or by pressing the *T* key to advance the time in one-hour intervals.

DAY 2

Take some aspirin and a shower. Go into the garage and turn on the car's radio. The radio message will tell you to leave some doors open before crossing over to the dark side. This message is referring to the secret passageway doors in the house. Make sure both doors are open during the entire game. If you enter or exit the secret passageway, the door will automatically close behind you. Therefore

you must open it again.

Note: Keep a close eye on the time during Day 2: You must meet Delbert at 6 p.m. sharp.

Enter the foyer and wait for the delivery man—he'll arrive at 10 o'clock. Open the front door and click the hand cursor on the package. It will contain a broken shard. Before visiting the dark side (via the mirror), you must have completed all the tasks mentioned in the *Day 1* section. If all the tasks have been completed, it's time to explore the mysterious dark side.

With both secret passage doors open, enter the living room. Click the shard on the mirror. Save the game. Enter the dark side by stepping into the mirror.

To understand the dark side, think of it as a crude reproduction of the normal side: You exit the living room of the normal side home and enter the living room of the dark side home. The general layout of the house is reproduced in the dark side. Don't let the contents of the rooms (in the dark side) confuse you—as they did me. Concentrate on the general structure of the house and the layout of the land. Then compare that with the layout on the normal side. You'll be surprised at how similar they really are. From the dark side living room travel through the center doorway and you'll be in the dark side foyer. (Notice how the skulls resemble the staircase of the normal side.) The door at the end of the skull staircase is the front door of the dark side house. You'll need to open this door. To do this, find the lever that opens it. From within the dark side foyer, walk west into the study. Look at the holographic image of the biological experiment. Take note of the person's name on the bottom of the image—isn't that your name!?

Walk one screen east, one screen north, then west (if any of these doors are closed,



you must go back to the normal side and open them). By now you should be standing on a round exterior balcony. You may take the binoculars, but they aren't necessary to complete the game. The lever to open the front door is located between the two large doors. Wear the gloves, as there are many volts running through that lever.

Retrace your steps until you reach the dark side foyer (where the skull staircase is located). Walk through the front doorway. Walk as far west as you can go. Enter the alien structure. Get the shovel. Check the time, make sure it's well before 6 p.m. (you wouldn't want to miss Delbert). Leave the dark side. If you still have some time, listen to the car's radio.

Wait for Delbert at the entrance to the garage. If you have time to kill, you can press the *T*key to advance the game time in one-hour intervals. When Delbert appears, follow him into the grove. Give Delbert the bottle of cheap Scotch. Get the stick. Save the game. Hustle to the cemetery (you must move very quickly, since you have to be home before the clock strikes 10). Follow the path into the cemetery. Dig up the last grave bearing the following name:

□ *J. McKeekan*

Get the note. Read the note. Head on home. To your surprise, the cops arrest you and throw you in the slammer (this is a normal gaming procedure). The reason they arrested you is because the police are under the control of the aliens and they now know that you've visited the dark side.

From within the jail cell, you must again move very quickly. Hide the watch, bobby-pin, gloves, and money under the pillow (don't worry—you'll get them back when you visit the dark side jail cell). Get the tin cup. Clang the cup on the cell bars. Give the officer the *Get Out of Jail Free* card Delbert gave you. Go home and get some rest—it's been a long day.

DAY 3

Take some aspirin and a shower. Travel to town. Enter the police department. Steal the gun. Travel to the house. Enter the dark side. Exit through the front doorway of the dark side home.

Walk east—in the direction of the dark side police department. Throw the

DARK SEED

stick into the abyss to get past the dog-like creature. Cross the abyss. Enter the dark side police department. Since you stole the gun from the normal side, the alien won't have one with which to shoot you. If you didn't steal the gun, the game will end.

From within the jail cell, retrieve your belongings from beneath the pillow. Use the bobby-pin to pick the lock of the cell door (you may need to do this twice). Once you're in the jailhouse corridor, an alien will beckon you. Click the exclamation-point cursor on the alien to find out what he wants. Sargo will offer you the gift of invisibility if you give him freedom. Agree to his request by giving him the bobby-pin. In return, he'll give you an invisibility ring.

Leave the dark side police department and walk east until you reach the dark side library (archive chamber). Click on the invisibility ring. When Mike begins to flash, he's invisible and can walk past the alien guard. From inside the great archive chamber, click the hand cursor on the large console located near the east side of the room. Look at the viewer. After the Keeper of the Scrolls has given you some clues, leave the dark side as fast as you can.

Check inventory and notice that the Keeper of the Scrolls has given you a microfiche card. You can view this card in the library. Exit the house via the rope. **DO NOT EXIT THROUGH THE FRONT DOORWAY.** If you do, you'll be arrested and the game will end.

Before reaching the library, enter the food market and purchase another bottle of Scotch. Travel to the library. Enter the east room. Turn on the microfiche viewer. Click the microfiche card on the viewer. Read the next clue:

❑ *Find a loose stone in the wine cellar*

Travel to the house. Walk through the kitchen, down the stairs, and into the wine cellar. Near the center of the room you'll find a loose flagstone. Get the stone and the car keys beneath it. Go directly to the garage (via the rope) and pour the Scotch into the gas tank. Save the game. Start the car. When the engine's running, you're on the strictest time limit of the entire game.

Quickly enter the dark side. Travel in the direction of the cemetery (west). Enter the alien structure. Continue north until you reach the organic computer. At the lower center of the organic computer you'll see the heart of the power nexus (it looks like a television screen). Get the loose rock from inventory and

energize it by placing it into the heart of the power nexus. Hurry back to the front of the dark side house. Enter the small opening located slightly to the west of the front door. From within the control center, locate the lever and turn on the power sequence while wearing the gloves. If nothing happens, you wasted too much time after starting the car. Remember, a car doesn't run long on only a pint of fuel. Restore the game and try again.

After starting the power sequence, leave the dark side. Exit your house through the front doorway—don't worry, the cop will be gone. Get the package. Open the package. Get the axe handle. Combine the axe handle with the energized rock and you'll have a powerful weapon that can be used to break the mirror.

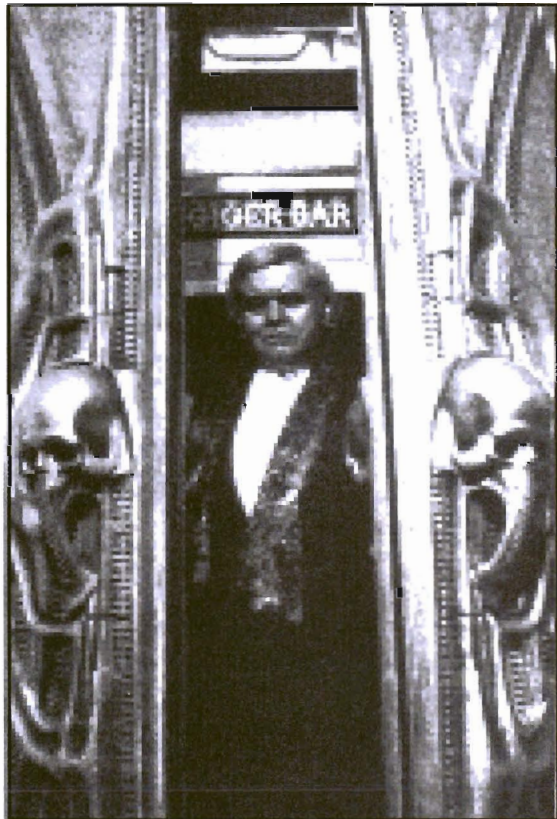

H.R. Giger

LOCATION OF OBJECTS

- Aspirin Bathroom (Medicine Cabinet)
- Axe Handle Delivery Man (Day 3)
- Binoculars Observatory (Not Needed)
- Blueprint Study
- Bobby-pin Library
- Bottles of Scotch Klug's Food Market
- Broken Shard Delivery Man (Day 2)
- Business Card Delbert (Klug's Food Market)
- Car Keys Wine Cellar
- Clock Key Joe Tuttle's Urn (Cemetery)
- Crowbar Trunk of Car
- Flagstone Wine Cellar
- Gardening Gloves Glove Box of Car
- Gun Police Department
- Invisibility Belt Alien (Dark Side Jail Corridor)
- Library Card Trench coat (Spare Bedroom)
- Microfiche Card Keeper of the Scrolls (Dark Side)
- Note J. McKeekan's Grave
- Old Diary Trunk in Attic
- Rope Secret Passageway
- Shovel Dark Side
- Stick Delbert's Backyard
- Stone Cellar
- Tin Cup Jail Cell
- Watch Under Trunk (Attic)

MAPS

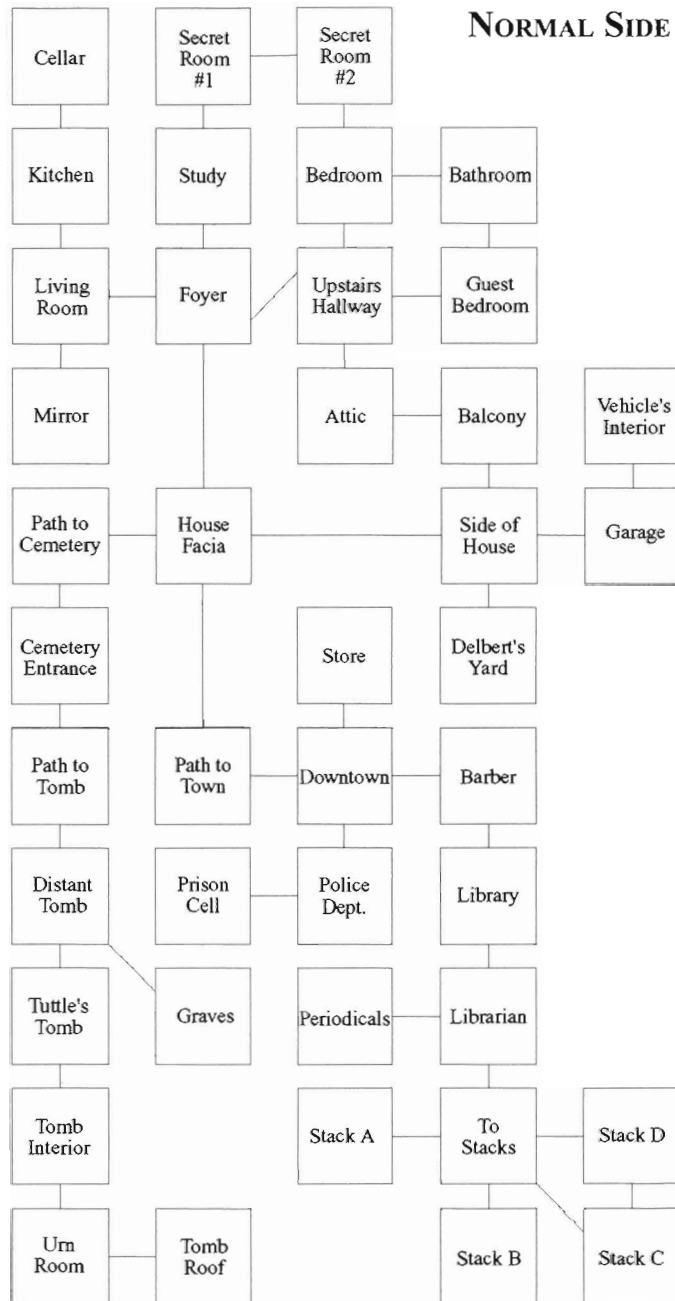

DARK SIDE

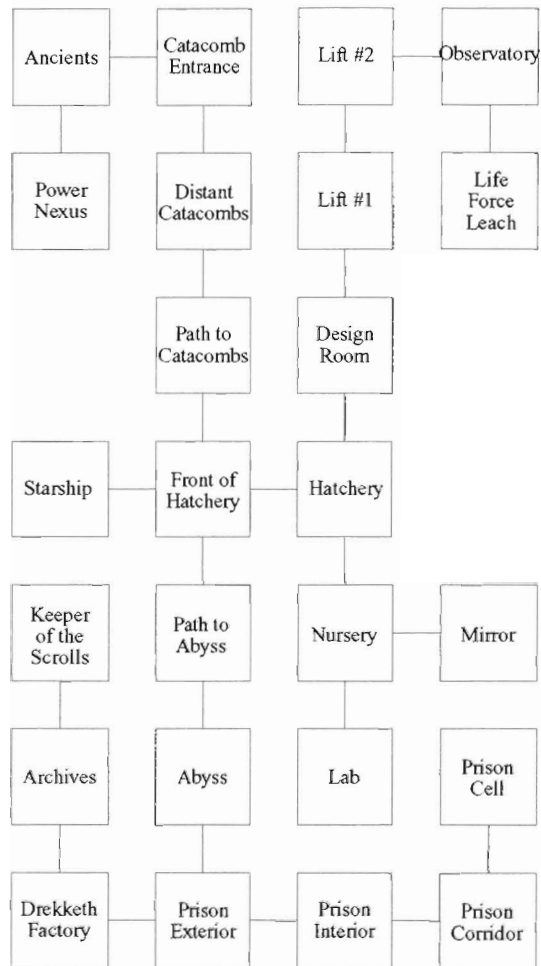

CHAPTER 11

MIXED-UP FAIRY TALES

GRAPHICS: ★★★

STORY LINE: ★★★★★

ARCADE: N/A

INTERFACE: ★★★★★

DIALOGUE: ★★

AUDIO: ★★★★★

ANIMATION: ★★

LENGTH: ★

OVERALL ANALYSIS: ★★★

SYSTEMS

- ❑ MS-DOS IBM-PC/Tandy & Compatibles

FEATURES

- ❑ *An easy-to-use, no-typing interface makes adventures fun even for the youngest reader.*
- ❑ *Mini-Quests feature five different fairy tales: Jack and the Beanstalk, Bremen Town Musicians, Cinderella, Beauty and the Beast, and Snow White.*
- ❑ *Randomly placed objects make each story fun to play over and over again.*
- ❑ *The stereo soundtrack introduces children to the world's great composers—Bach, Beethoven, Mozart, Vivaldi, and many others.*
- ❑ *Includes a beautiful coloring book, crayons, and an illustrated storybook.*
- ❑ *Up to 20 children can save games by name, making it ideal for families, classrooms, and play groups.*



SCENARIO

Bookwyrms' Mixed-Up Fairy Tales by Lori Cole of Sierra On-Line allows our children to interact with their favorite fairy tales, including Cinderella, Snow White, Jack and the Beanstalk, and many others. Using only two cursors, the interface is very simple. And to prevent confusion caused by a massive inventory, only one item can be carried at any given time. If you have a soundboard installed in your system, you'll enjoy the magnificently prepared musical score playing many classical themes.

WALK-THROUGH

BEAUTY AND THE BEAST

After a short animated sequence, leave Bookwurm's home by walking south. Walk north to the crossroads. Then follow the sign pointing toward town. Once in town, walk one screen west and you'll have the pleasure of meeting Belle. Talk to her. Click on the Fairy Tale icon and select



Beauty and the Beast

From Belle's house, leave town by walking east. Find Belle's father by traveling to the Beast's lair located in the southern section of the map. Talk to Belle's father. He'll ask you to find a rose. Walk past the gate and enter the maze. To get the rose, click the hand cursor on it. Give the rose to Belle's father. The ugly beast will now come forth. (And he's very upset because you've picked a rose from his garden!) He'll demand to see Belle. To find her, walk to the bridge. Talk to Belle. Escort her to the Beast's lair. She'll agree to marry him, thus breaking the evil spell.

Note: *The location of objects is randomly generated. If a certain object can't be found, talk to Bookwurm—he'll steer you in the right direction.*

BREMEN TOWN MUSICIANS

Your first puzzle is to find the rooster. I found the feathered friend near the bridge. Once you find him, click on the Fairy Tale icon and select

Bremen Town Musicians

MIXED-UP FAIRY TALES

The rooster will ask you to take him to the crossroads. To get there from the bridge, walk one screen east, then one screen north. Now you must find a cat somewhere in the forest. Walk one screen south and talk to Bookwurm: He'll disclose the general location of the feline. I found the cat hiding in a tree one screen south of the bridge. Once you find the cat and talk to her several times, you'll realize that she was frightened by Bookend—the little troublemaker! After she agrees to go with you, take her to the crossroads (one screen north of Bookwurm's house).

The rooster will now ask you to find a dog named Scot. Ask Bookwurm where to look. I found Scot near Bookend's cave. Take Scot to the crossroads and the rooster will have yet another request—find a donkey. To find the donkey (from the bridge), walk one screen south, then one screen west. Untie the donkey. Take him to the crossroads and enjoy the short animated sequence.

CINDERELLA

Travel to town, then walk one screen north. When you see a weeping woman sitting on a bench, you've found Cinderella. Talk to her. Click on the Fairy Tale icon and select

Cinderella



Cinderella needs a pumpkin to get to the dance. And guess what? You're the one who must find it. Leave town and travel to Bookwurm's house. Ask him where the pumpkin is. Give the pumpkin to Cinderella. After she leaves, walk

one screen west and you'll witness Bookend stealing Cinderella's slipper. Chase Bookend. Eventually he'll drop the slipper and you can return it to Prince Charming.

JACK AND THE BEANSTALK

To find Jack, begin at Cinderella's house and walk one screen east. Talk to Jack. Click on the Fairy Tale icon and select the following choice:

 Jack and the Beanstalk

Jack will ask you to find his Magic Beans. If you have trouble finding the beans, ask your ol' buddy Bookwurm. Return the beans to Jack and he'll plant them. After the beanstalk grows, Jack will climb it. Since you can't climb over the wall, you'll need to reach the beanstalk another way. First, leave town. Then walk around the outer perimeter of the town's wall. From the crossroads, follow the sign that reads *Bremen*, then walk north.

Jack will be ranting and raving about a giant who's chasing him. To kill the Giant, Jack must cut down the beanstalk. Go find Jack an axe.

SNOW WHITE

Comb the forest and you're bound to run into Snow White. Talk to her. Click on the Fairy Tale icon and choose the following:

 Snow White

To find the Dwarf home, click on the map icon and look in the southwest corner of the map. Escort Snow White to the Dwarf home. Visit Bookwurm and he'll tell you that Snow White needs your help. After finding Snow White, the Dwarfs will ask you to find Prince Silver. I found the Prince (tied to a tree) one screen south of Bookwurm's house. Talk to the Prince. Untie him and take him to see Snow White. With his kiss, she'll awaken from the evil spell.



CHAPTER 12

KING'S QUEST V

GRAPHICS:	☆☆☆☆	STORY LINE:	☆☆☆
ARCADE:	N/A	INTERFACE:	☆☆☆☆
DIALOGUE:	☆☆☆	AUDIO:	☆☆☆
ANIMATION:	☆☆☆☆	LENGTH:	☆☆☆☆

OVERALL ANALYSIS: ☆☆☆☆☆

SYSTEMS

- MS-DOS IBM-PC/Tandy & Compatibles
- Amiga
- Macintosh
- VIS CD-ROM

FEATURES

- A rich, complex story with highly developed characters.*
- The most beautiful and detailed graphics ever seen in a Sierra 3-D adventure game.*
- Delightful original stereo soundtrack.*
- No typing required. A simple new interface permits complex game interactions without typed input.*



SCENARIO

One peaceful day in May, you, Sir Graham, decide to take a jaunty stroll into the realm of a gloomy forest, only to witness the entire castle of the Royal Family of Daventry vanish into thin air. Bound by allegiance, you set forth undaunted to seek the answers behind the mystery of the missing castle. This enchanted quest by Roberta Williams, entitled *King's Quest V: Absence Makes the Heart go Yonder*, truly has a heart of its own. It combines full-screen, kaleidoscopic graphics with the pulse of whimsical music, pumping the fantasy into a vein of mini-adventures. Your adventuring skills will determine whether or not you'll encounter one of the 39 different ways you can die. Selected as "Adventure Game of the Year" by *Computer Gaming World* and "Best Fantasy Role-Playing/Adventure Program of 1990" by

the Software Publishers Association, *KQ5* is one of the hottest adventure games on the market. In addition, *KQ5* uses Sierra's new, highly advanced point-and-click icon interface. This interface allows you to cycle through the cursors using the right mouse button or by moving the current cursor to the top of the screen. During the introduction (which is more than 10 minutes in length) do *not* issue any keystrokes or depress the mouse buttons. If you do, the introduction will recycle itself—so, just sit back, grab a handful of heavily buttered popcorn, and enjoy the colorful animated introduction.



Cedric, the talking owl.

WALK-THROUGH

PART 1: SERENIA

Begin your journey by following Cedric's advice—travel to Serenia by walking two screens south. Enter the alleyway. Look inside the old wooden barrel. Get the fish. Enter either shop. Return to the main street and get the lost coin (located in the alleyway). Leave Serenia by traveling west. Continue walking west until you reach the Baker Brother's Bake House.



Enter the bake house and purchase a custard pie with the silver coin you found in the alleyway. Leave the bakery. Walk along the path until you're directly behind the bake shop. Talk to the sulking Prince. Walk one screen south, then walk west (past the Swarthy Hog Inn). When you encounter a bear attacking a beehive, get the fish from inventory and toss it to the bear. Queen Beatrice will offer you a luscious honeycomb from her hive. Get the honeycomb. Also, get the stick located near the foot of the tree. Walk one screen north and you'll see a dog attacking an ant hill. Throw the stick to the dog. For your gallant effort, King

Antony the Great will offer you his help. Travel to the haystack just east of the Swarthy Hog Inn. Click the hand cursor on the haystack and (with the help of the ants) you'll find a golden needle. Now it's time to venture into the desert by walking west. Save the game before, during, and after the desert expedition.



THE DESERT

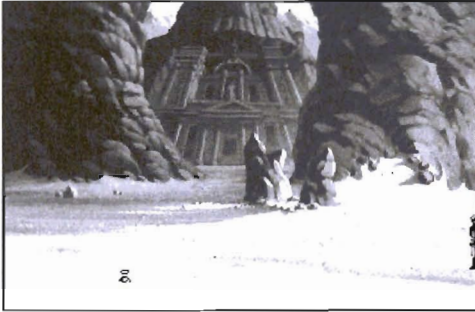

Enter the desert by walking west. Continue walking west until you reach an oasis. Take a drink by clicking the hand cursor on the water. Do this every time you reach an oasis. Also, it may be wise to save the game at every watering hole—just in case you get lost within the vast desert. After reaching the first oasis, walk due north

until you encounter a wall of rocks (if you get lost, refer to the map at the end of this section). Walk west to reach the temple's entrance. Get a drink of water. When you hear hoofbeats, hide behind the rocks near the watering hole. Watch the bandits carefully. Pay special attention to the way they open the temple door. After the bandits leave, try opening the door by clicking the hand cursor on it. Get a drink of water. Travel three screens south and two screens west. From this oasis, walk east until you reach the skeleton. Get the old shoe. Walk south until you reach yet another oasis. Take a drink of water. Walk four screens west, then head due south until you reach the bandit's hideout. Enter the first tent and quietly get the staff (be sure to keep a safe distance from the sleeping bandit—you wouldn't want to wake him). Exit the tent. Get a drink of water from the large clay jar near the campfire. (A campfire? In the desert?) Walk west, then north to reach yet another oasis. Take a swig of water. Travel two screens west, then north until you reach the temple. Take another drink of water. Approach the temple door. Save the game. Open the door with the staff. Now you only have time to get the following two items—so don't dilly-dally:

- The gold coin
- The brass bottle

After retrieving the bottle and the coin, exit the temple (don't open the bottle). Get another drink of water. Walk two screens south, then west until you reach another oasis. After quenching your thirst, you can leave the desert by traveling due east.

THE GYPSY, WILLOW, WITCH, AND GNOME



From the beehive, walk north and you'll reach the gypsies. Approach the covered wagon and give the man a gold coin. Madame Mushka will give you a fortune, along with a magic amulet. Leave this scene by walking east. Talk to the weeping willow: Find out why she's so sad. Leave this scene by traveling east. Welcome to the witch's forest. Before you dare to enter, click

the amulet on Graham. Take a deep breath, then walk north into the dark forest. When you reach the fork, go left. Follow the path until you spot the wicked witch. Since you're wearing the amulet, her powers are rendered useless. Give her the brass bottle (which you found in the desert temple) and witness her greed beget her own demise. Walk behind the large tree containing a door. Enter the witch's house. Use the game documentation to pass the off-disk copy protection. Open the trunk and get the spinning wheel. Use the eye cursor to locate the incense burner. Use the hand cursor to retrieve the golden key from inside the burner. Finally, locate the table and open the drawer. Get the pouch. Look inside the pouch. Exit the witch's house.

After crossing the bony bridge, travel east. Follow the curvy path until you reach the tree with a small door. From inventory, get the golden key and open the tree door. There you'll find the Princess's golden heart. Now try to leave the forest. If you can't find your way out (and believe me, you won't) go back to the



witch's house and travel one screen west. Click the honeycomb on the path. Place an emerald on the honeycomb. An elf will appear and snatch the beryl. Drop all three emeralds. Once you catch the elf, he'll lead you out of the forest (he'll also give you a very special pair of shoes). From the entrance to the witch's forest, travel west. Click the



golden heart on the willow tree and a beautiful Princess will appear. She'll discard her harp. Get the harp. Walk one screen west. Get the tambourine. To reach the village of the gnomes, walk one screen south, then east. Speak to the youngest gnome. Give his father the spinning wheel. For your kindness,

he'll give you a marionette. From the village of the gnomes, walk two screens east. When you encounter a venomous viper, click the tambourine on him. But don't take the east path yet—you need to go to town first. To reach town from your present location, walk due south. Enter the tailor shop. Click the hand cursor on the blue cloak. Exchange the golden needle for the cloak. Enter the toy shop. Give the toymaker the marionette. In return, he'll give you a sleigh. Enter the shoe shop and give the shoemaker the pair of special shoes. He'll give you a cobbler's hammer. That's about all you can do in downtown Serenia. Head back to the bake house by traveling west. Save the game. Throw the old shoe at the



cat. Enter the bake house and you'll be captured. Not to worry—the rat will free you. Get the rope. Use the cobbler's hammer on the door lock. Enter the kitchen and find the cupboard. Open the cupboard and get the leg of lamb. Exit the kitchen through the west doorway.

PART 2: THE SNOWY MOUNTAINSIDE

From the Swarthy Hog Inn, walk north (past the small barn and behind the haystack). Travel three screens east and you'll reach a snowy mountainside. Since it's very cold here, wear the cloak. Follow the path until it ends. Save the

game.

Use the rope to lasso the rock (don't lasso the tree limb). After the copy-protection sequence, climb the rope by clicking the hand cursor on it. Give Graham the leg of lamb. To join Cedric, you must cross the boulders. But be very careful—some boulders are too weak to support Graham's weight. Stay off the two southernmost boulders. Walk across the fallen log. After the wolf seizes Cedric, use the sleigh to get down the cliff. When you encounter a shivering eagle, give him what's left of the leg of lamb and he'll help you later in the game.

Before entering Queen Icebella's castle, slow down the game by adjusting the appropriate lever. Save the game, then enter the castle. When Queen Icebella orders her wolves to kill you, play the harp and she'll spare your life—for a price. She'll order you to defeat the mighty Yeti. With the game still running in slow speed, walk to the mouth of the cave and get ready for action. When you see Yeti, throw the custard pie at him. He'll stumble and fall off the edge of the cliff. Enter the cave. Use the cobbler's hammer to loosen the crystal. Take the crystal to Queen Icebella as proof of your victory.

When you're on a confusing, windy path, walk near Cedric. Notice the pool of water directly behind him. Next to the pool is an opening in the cliff. Climb through that opening and you'll be captured by a giant bird. From within her nest, get the golden locket, then wait for the eagle to rescue you.

PART 3: HARPIES ISLAND

On the beach you'll find a rusty iron bar. Walk north to reach the boat. Before you make sail to Harpies Island, you must fix an unforeseen leak. Click on the inventory icon and retrieve the softened lump of beeswax. Click the beeswax on the boat. Save the game. When you're ready to shove off, click the hand cursor on the boat. To avoid the sea creature, travel one screen south, then due east.

Welcome to the island of the harpies. To avoid these flesh-eating weirdos, play the harp while they speak. A fight will break out, giving you plenty of time to escape. Before leaving this scene, get the fish hook buried in the grass.

Hint: Don't walk north. If you do, you'd better know how to fly.

Travel west and you'll find poor, injured Cedric. Click the hand cursor on him. Walk west to return to the boat. Before leaving the isle, find and take the conch shell. Save the game. Click the hand cursor on the boat. Make sail due west and you'll land on the beach near a makeshift house.

THE HERMIT

Approach the makeshift house. Knock on the door. Ring the ship's bell. If you're trying to communicate with the hermit but he can't hear you, give him the conch shell. Follow the hermit inside the makeshift house and wait for him to cure Cedric with poultices. After Cedric has been cured, the hermit will summon a beautiful mermaid named Pearl. She'll lead you to Mordack's island.

PART 4: MORDACK'S ISLAND

Welcome to your final destination, Mordack's island. Unfortunately, there's no escaping this place—especially since you, the Captain, shattered your boat into a million slivers by ramming the hull into the rocks.

If you haven't already done so, save the game. Get the dead fish from the beach. Walk north (up the winding staircase). When you reach the dragon statues, get Yeti's crystal and click it on Graham: This will protect him from the laser eyes. At the castle's entrance, locate the stairway near the left side of the screen. Use this staircase to enter the edifice. Pry open the rusted grate with the heavy metal bar. Click the hand cursor on the opening of the labyrinth. Weave your way through the labyrinth until you find a large beast (dink). Give the tamborine to the dink. He'll dance a funny dance, then drop a hairpin. Get the hairpin. Travel through the maze until you find the exit door. Use the hairpin to pick the lock. From within the pantry, get the dried peas from the cupboard. Walk north into the kitchen. Talk to the lovely lady scrubbing the kitchen floor. Give her the golden locket. Leave the kitchen through the east doorway. Walk directly past the pipe organ (resisting any temptation to play it). Enter the dining room. Walk around the dining area until you're captured by a blue security beast. After being locked inside a dark, dingy holding cell, locate the mouse hole. Use the fish hook to snag the moldy cheese. After you have the cheese, Princess Cassima will rescue you (if you gave her the locket earlier in the game). Click the hand cursor

KING'S QUEST V

on the large opening in the wall to exit the cell. Weave your way through the labyrinth until you find the exit door. Enter the pantry. Walk into the kitchen. Thank Princess Cassima for rescuing you from the cell. Walk east until you reach the dining room. When the blue beast attacks you, throw the dried peas at him. This will cause him to trip and fall. Continue with your quest by walking south. Walk through the southwest doorway. From the foyer, clamber up the staircase. Enter Mordack's bedroom by walking west. Travel south, into his study. Find the large tome (book) laying on Mordack's desk. Click the hand cursor on the tome to learn the four spells necessary to defeat Mordack. The spells are

- Tiger spell
- Mongoose spell
- Rabbit spell
- Rain-cloud spell

Wait patiently (in the study) for Mordack to appear in the bedroom. After he goes to sleep, snatch his magic wand from the nightstand. Be careful not to wake Mordack—the consequences would be very severe. Leave the bedroom by traveling east. Continue traveling east until you reach the laboratory. Walk up the spiral staircase. Walk as far east as you can go. There you'll find a large machine. Place both wands (Mordack's and Crispin's) into the machine. Place the moldy cheese into the machine. The machine will then drain most of the power from Mordack's wand and place it into Crispin's wand. Get Crispin's wand! Mordack will suddenly appear in the laboratory. He'll consecutively change into the following four items:

- Flying beast
- Dragon
- Cobra
- Ring of Fire

To defeat Mordack, click the magic wand on him (when he changes into the flying beast) and choose the tiger spell. When he changes into a dragon, use the rabbit spell. When he changes into a cobra, use the Mongoose spell. And finally, when he changes into a ring of fire, use the Johnny Cash spell—er, I mean the rain-cloud spell.

LOCATION OF OBJECTS

- Blue Cloak Tailor Shop
- Brass Bottle Temple (Desert)
- Cobbler's Hammer Shoemaker
- Coin Alleyway (Serenia)
- Conch Shell Harpies Island
- Crystal Yeti's Cave
- Custard Pie Baker Brother's Bake House
- Dead Fish Mordack's Island
- Dried Peas Pantry (Mordack's Island)
- Emeralds Table Drawer (Witch's House)
- Fish Alleyway (Serenia) / Beach
- Fishhook Harpies Island
- Gold Coin Temple (Desert)
- Golden Key Incense Burner (Witch's House)
- Golden Locket Giant Bird Nest
- Golden Needle Haystack
- Harp Willow Tree
- Hairpin Dink in Labyrinth
- Honeycomb Queen Beatrice
- Leg of Lamb Kitchen (Bake House)
- Magic Amulet Madame Mushka
- Marionette Gnomes
- Moldy Cheese Holding Cell (Mordack's Island)
- Mordack's Magic Wand Mordack's Bedroom
- Old Shoe Skeleton (Desert)
- Rope Bake House (after being captured)
- Rusty Iron Bar Beach
- Shoes Elf (Witch's Forest)
- Snow Sled Toymaker
- Spinning Wheel Witch's House
- Staff Bandit's Hideout (Desert)
- Stick Foot of Tree (Beehive)
- Tamborine Gypsy's Campsite

MAPS

SERENIA

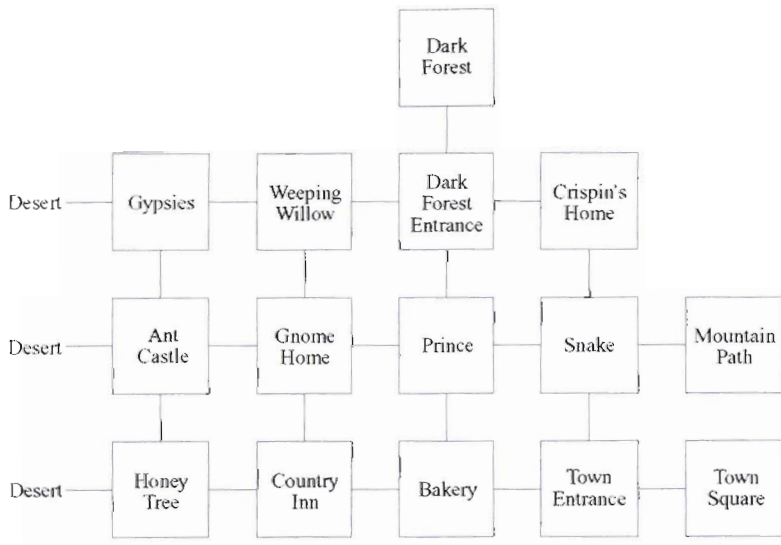

DARK FOREST

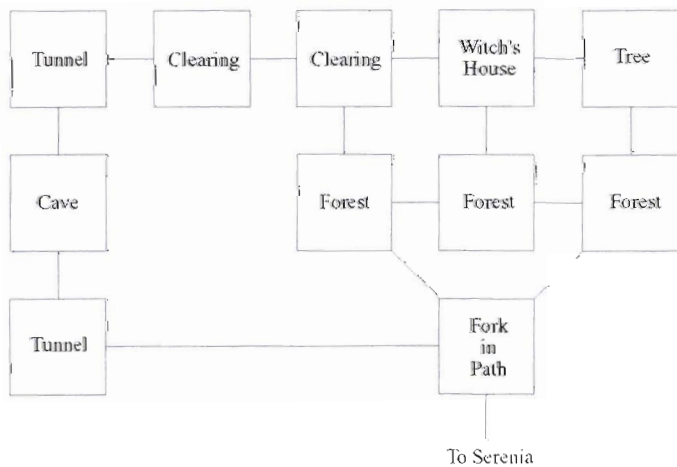

GREAT MOUNTAINS

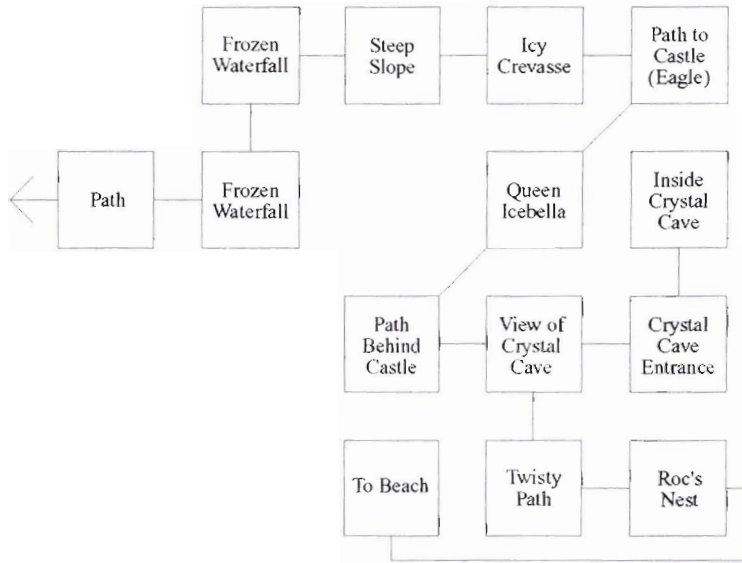

BEACH AND OCEAN

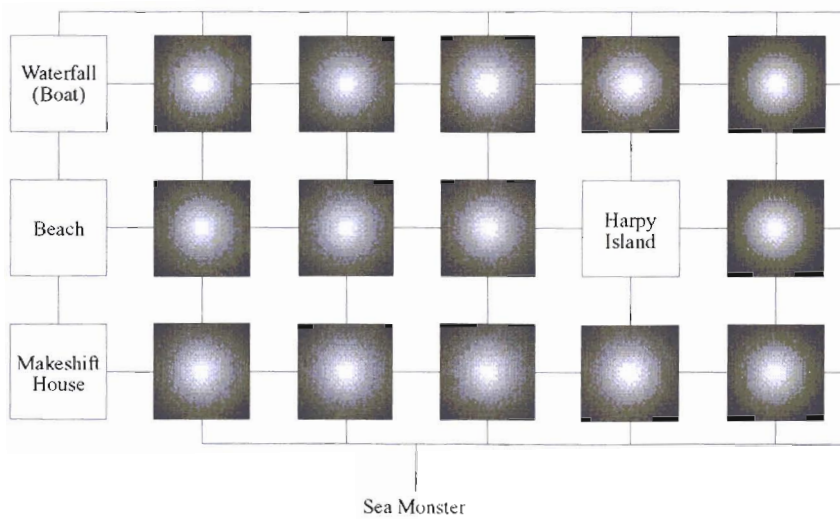

MORDACK'S ISLAND

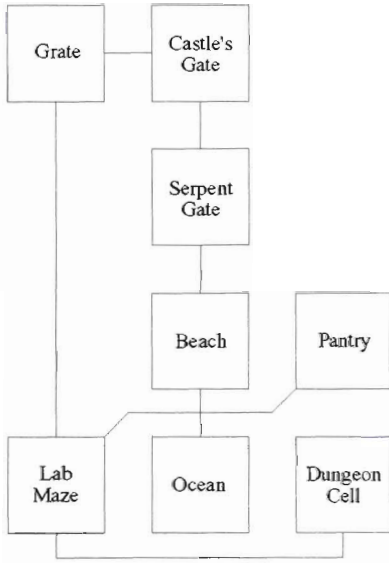

MORDACK'S CASTLE

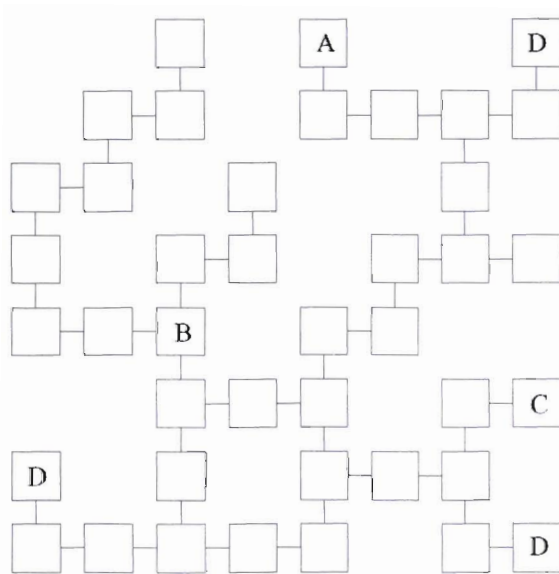
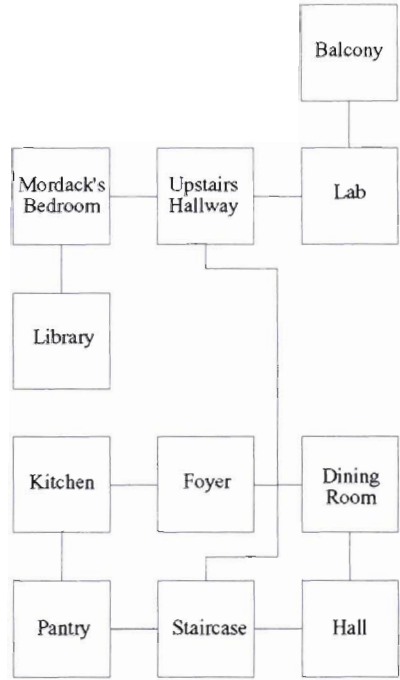

LABYRINTH

- A= Door
- B= Hole
- C= Cell
- D= Dink

SECTION 2

KING'S QUEST VI

GRAPHICS:	☆☆☆☆	STORY LINE:	☆☆
ARCADE:	N/A	INTERFACE:	☆☆☆☆
DIALOGUE:	☆☆	AUDIO:	☆☆☆
ANIMATION:	☆☆☆☆	LENGTH:	☆☆☆☆
OVERALL ANALYSIS: ☆☆☆☆			

SYSTEMS

- MS-DOS IBM-PC/Tandy & Compatibles
- Amiga
- Macintosh
- CD-ROM

FEATURES

- More flexible game design allows you to overcome obstacles in almost any order.*
- More puzzles and a greater variety of challenges than any other King's Quest episode.*
- Multiple paths and different endings. Nearly half of the game action is optional.*
- A cast of costumed, video-captured live actors brings the adventure to life.*
- More than two hours of original music.*



SCENARIO

Continue this award-winning saga by tackling Roberta Williams's latest adventure, *King's Quest VI: Heir Today, Gone Tomorrow*. *KQ6* flaunts nonpareil mastery of technology, such as the art of scaling (when the main character shrinks as he or she walks away from the viewer). Furthermore, the opening animation sequence presents a unique 3-D rendering using a flying camera technique that's just fantastic on a 486 50-MHz system using CD-ROM. But wait—there's more. Sierra On-Line has changed its gaming strategy: Now you can get from point A to point B, with less frustration (although Sierra has left a few loopholes that can snag even the most avid adventurer). And to accommodate everyone's abilities, the game is easy—yet difficult. If you're an experienced adventurer, the game will adjust accordingly and take you through a lengthier, more sophisticated ending. If you're a novice, *KQ6* automatically shifts into novice mode, taking you through an entirely different, more simplistic ending. In addition, the many inconspicuous jokes and puns strategically scattered throughout the story will have you chuckling aloud (if a game doesn't make you laugh, is it really a game?).

WALK-THROUGH

ISLE OF THE CROWN

Embark on your quest by examining the entire area. Find and take Alexander's royal insignia ring. Move the large plank to reveal a treasure box. Open the box by clicking the hand cursor on it. Get the copper coin. Walk one screen north and you'll encounter a fork in the road. To reach town, take the left branch.



After conversing with the old beggar peddling lamps, enter the Pawn Shoppe. Talk to the merchant. Examine the items on the counter. Give the merchant the copper coin that you found in the treasure box. Get the mechanical nightingale from the counter. Exit the pawn shop.

Search the large round pot (next to the staircase leading to the pawn shop). Enter Ali's bookstore. Talk to the owner. Search the many rows of books (right side of screen) until you find a poem. Get the poem (fallen page). Attempt to converse with the man in the black robe. You'll soon realize, however, that you're only wasting your time with this guy. So, if you haven't already done so, have a seat in the big red chair. Then get the bargain book near the entrance door. You can now exit the bookstore. Walk one screen north and one screen west.

Hint: *Ignore the youngster swimming in the ocean (he may be a genie in disguise). If you oblige his request, you'll die.*

Enter the ship's cabin. Talk to the ferryman. Get the rabbit's foot from the table. Exit the ship and find the Castle of the Crown (to reach the castle, begin at the docks; walk one screen north, one screen east, one screen south, and one screen east). Talk to the guardsman twice, then show him your insignia ring. If you're

persistent, he WILL allow you passage into the castle. After your tryst with Captain Saladin and Vizier Alhazred, travel back to town. Enter the Pawn Shoppe and take a mint from the blue glass jar located on the edge of the counter. Exit the pawn shop and enter the bookstore. Talk to the man sitting in the red chair (Jollo). Show him the insignia ring and he'll give you pertinent information about Cassima. After he leaves the store, look at the leather-bound book on the counter. Click the hand cursor on the spell book and the merchant will tell you that he'll barter the spell book for a rare book. At this time, exit the bookstore and enter the pawn shop. Talk to the merchant, then give him the insignia ring in exchange for the magic map. Leave the pawn shop and walk to the beach. Use the magic map to travel to the Isle of the Sacred Mountain.

Hint: The magic map only works when you're near sea water.

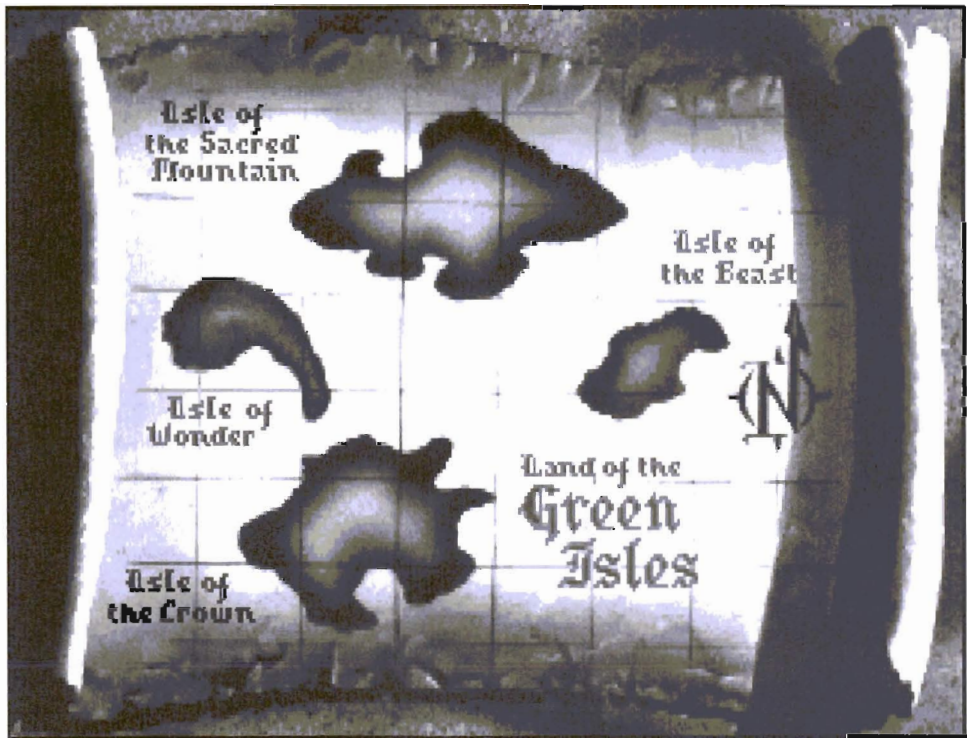

ISLE OF THE SACRED MOUNTAIN: VISIT 1

Being the experienced adventurer that you are, you've already picked up the flower (note the pungent odor) and the black horse feather from the beach. You may even have noticed the etching in the cliff's face. But before trying to climb the cliff, there are some things you must do first, like visiting another isle. Use the magic map to travel to the Isle of Wonder.

ISLE OF WONDER: THE OYSTERS

Welcome to the Isle of Wonder: a perfect place to SAVE THE GAME. Now follow these instructions precisely. Look at the oysters. Talk to the insomniac oyster. (Have you read the bargain book you found in the bookstore? If not, read it now.) Click the bargain book on the oyster. When the oyster's mouth (shell) is open, snatch the pearl.

Have you noticed the red, snake-like object floating in the water? Walk slightly east (remaining near the seashore). Wait for the letters to float into reach, then grab the incomplete sentence.

Hint: Don't walk north or east—if you do, you'll die.

Now use the magic map to travel to the Isle of the Crown.

ISLE OF THE CROWN: VISIT 2

Enter the pawn shop. Give the merchant the pearl in exchange for the insignia ring. Exit the pawn shop. Search the large pot near the staircase and you'll find a bottle of invisible ink. Walk to the big tree (fork in the road). Click the eye cursor on the *real* nightingale. Lure Sing Sing to a lower branch by utilizing the mechanical nightingale. Give Sing Sing the insignia ring. When the bird returns, pick up the red ribbon. Look at the ribbon. Click the hand cursor on the ribbon and you'll discover a strand of black hair. Give Sing Sing the love poem and she'll return with a note from Cassima. Get the note. Before traveling to the Isle of Wonder, be sure to have the following items in inventory:

- Invisible ink (large pot in front of pawn shop)
- Flower of odor (Isle of the Sacred Mountain)
- Rabbit's foot (ship)
- Mint (pawn shop)
- Mechanical nightingale (pawn shop)

ISLE OF WONDER: ISLE GUARDS

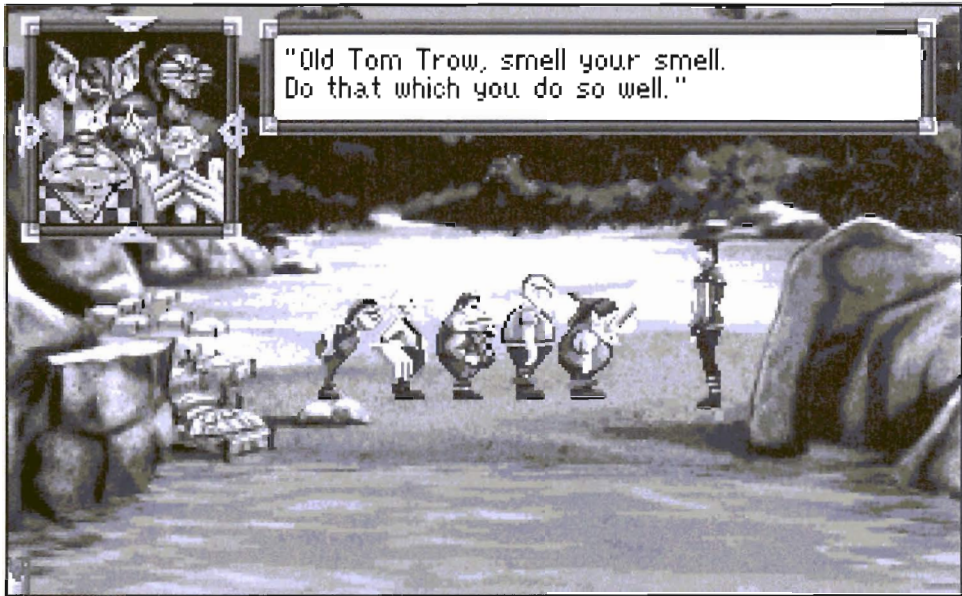

Save the game. From the seashore, walk north. The following procedure explains how to outwit the guards:

- Use the flower to deceive the first guard.
- Use the mechanical nightingale on the second guard.
- Use the mint on the third guard.
- Use the rabbit's foot on guard four.
- Use the invisible ink on Alexander to deceive the fifth guard.

After you elude the guards, they won't return—but there are other dangers lurking about.

KING'S QUEST VI

Walk one screen north. Click the hand cursor on the cat-tails. Get some milkweed from the foot of the dogwood tree. Walk one screen west. Talk to the tomato vines. Get the rotten tomato. Look at the hole in the wall (right side of screen). Click on the double doors. Talk to the Knights.

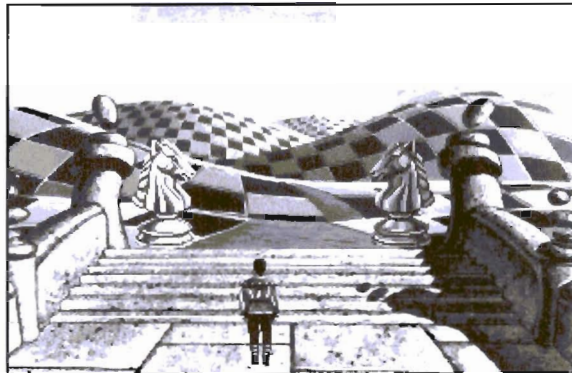

Get the red scarf from the red Queen. Walk three screens south, one screen east. Look at the spiderweb and note the piece of paper. Pull the loose thread located near the bottom of the web, then quickly grab the piece of paper. The paper contains the answer to a puzzle that you'll encounter later in the game.

Click the hand cursor on the stack of books (center of screen). After conversing with the caterpillar, walk back to the mystical garden and grab a cold head of lettuce (the lettuce melts rapidly, so keep on your toes). Travel to the Isle of the Beast.

ISLE OF THE BEAST: VISIT 1

Look at the odd creature dangling from the tree branch (hanging participle). Talk to him. Give him the partial sentence. After he agrees to travel with you, walk one screen north.

Throw the *cold* head of lettuce into the water to cool the boiling pond. Cross the pond and get the old hunter's lamp. Walk north until you reach a stone barrier (note the archer).

Hint: *Don't walk past the stone barrier.*

Get the brick, then leave the isle. Travel to the Isle of Wonder and give the miniature dragon/possum (hanging participle) to the caterpillar. In return, he'll give you a rare book. Do you remember who requested a rare book? Travel to the Isle of the Crown and give the rare book to the bookseller. In return, he'll give

you a spell book. Read all three (3) spells in the spell book.

Hint: To turn the spell book's pages, move the cursor until it changes into an arrow.

Exit the bookstore and read the sign on the wall near the archway. Enter the pawn shop. Exchange the mechanical nightingale for the flute. Travel to the Isle of Wonder.

ISLE OF WONDER: VISIT 3



Walk one screen north, one screen west. Get the teacup from the chair. Play the flute for the wall flowers. Retrieve the hole in the wall. Give the bottle of milk to the baby's tears plants. Gather some tears in the hunter's lamp. Travel to the Isle of the Sacred Mountain.

ISLE OF THE SACRED MOUNTAIN: THE CLIFF

Examine the etching in the face of the cliff. The answer to the riddle can be found on page 33 of the game documentation (copy-protection). Spell the four-letter word by clicking on the appropriate letters of the etching (start from the top and work downward).

After solving the first riddle, save the game. Carefully climb the protruding boulders to reach the second puzzle. Look at the etching. The answer to the second puzzle is

❑ SOAR

KING'S QUEST VI

On pp. 30-31 of the game documentation you'll find the codes for the corresponding symbols. The answer to the third riddle can be found on p. 33 of the game documentation (begin with button number four). The fourth answer is

❑ DOQG

Use the decoder on pp. 30-31 of the game documentation to locate the letter symbols. The fifth answer can be found on p. 33 of the game documentation. When you reach the top of the cliff, avoid eating the nightshade—unless, of course, you have an infatuation with death. Walk north, ignoring the old woman, and you'll meet the mighty Winged Ones.

After conversing with the Winged Ones, travel to the Isle of the Crown and



swap the flute for the tinderbox. Now travel back to the Isle of the Sacred Mountain. Save the game, then scale the cliff.

ISLE OF THE SACRED MOUNTAIN: THE CATACOMBS

After entering the catacombs, walk three screens north, one screen west. To cross the spike maze, refer to map at the end of this section, or use the path below:

- Rose
- Rose
- Rose
- Scythe
- Crown
- Dove
- Skull and Crossbones



Leave the spike maze by walking one screen north. Get the shield from the west wall (the shield will protect you from the stone archer on the Isle of the Beast). Walk three screens north, two screens west. Get the gold coins from the skeleton. Walk two screens east, one screen south, and one screen east.

By now you should be in a room containing large, revolving gears. These gears, by the way, are turning shafts which are attached to pulleys which are attached to chains which are attached to counterweights which are attached to more chains which are attached to a moving ceiling slab. And the ceiling is moving in your direction! If you don't react quickly, the slab will squash your chances of winning. To incapacitate the mechanism, use the brick to jam the gears.

From the gear room, walk two screens east, one screen north, and one screen east. Prepare to tumble through a trap floor and land in the depths of the catacombs. After this occurs, use the tinderbox for light. Walk five screens west, two screens south, and one screen east. Place the hole in the wall on the east wall. Look through the hole in the wall and you'll witness the minotaur opening a secret passageway. Now walk one screen west, two screens north, five screens east, four screens south, three screens west, and two screens north (whew). Click the hand cursor on the tapestry. Before entering the secret room, save the game. Enter the secret room and approach the minotaur. Before he charges you, click the red scarf on Alexander (O'Lay). If you defeat the minotaur, Lady Celeste will reward you with a dagger. The Winged Ones will abide by their promise by taking you to the Oracle. After obtaining sacred water from the Oracle, travel to the Land of the Green Isles.

KING'S QUEST VI

LAND OF THE GREEN ISLES: VISIT 1

Upon landing on the isle and saving the game, walk one screen west. Get the wooden-handled scythe hanging against the bearskin. Get a lump of coal. Walk one screen south and travel to the Isle of the Beast.

Hint: Don't investigate the sound of the beating drums.

ISLE OF THE BEAST: VISIT 2

Walk two screens north and click the wooden shield on Alexander. This will protect him from the stone archer. Walk toward the gazebo. Use the scythe to pass through the rose hedges. Meet the Beast. After uttering a very familiar story, the Beast will give you his family ring. Walk one screen south and get a white rose from the rose hedges. Travel to the Isle of the Crown. Mosey through town and you'll encounter Beauty attending to her rose hedges. Talk to her, then give her the white rose and the Beast's family ring. After the predictable union, you'll obtain the Beast's mirror and Beauty's clothing. Now read the second spell in the spell book:



Make Rain

To make this potion, add the sacred water to the baby's tears in the hunter's lamp. Then place the lamp under the fountain to obtain flying water.

ISLE OF WONDER: VISIT 4

For the fourth time, travel to the Isle of Wonder. Walk one screen north, one screen west. Get the bottle from the coffee table. Drink the unknown substance to learn of its effects. Click the hand cursor on the double doors. Give the white Queen the lump of coal. In return, she'll give you a spoiled egg (sulfur). Walk two screens south and dip the teacup into the mushy swamp. Talk to the bump

on the log. Give the rotten tomato to the bump. Use the teacup to gather some swamp ooze from the bump. Now travel to the Isle of the Sacred Mountain.

Hint: *Be sure you have the tinderbox prior to traveling to the Isle of the Sacred Mountain.*

ISLE OF THE SACRED MOUNTAIN: PEPPERMINT

Carefully scale the treacherous cliff. When you reach the crest, click the hand cursor on the small cave next to the nightshade (be careful not to click on the poisonous nightshade). Use the tinderbox for light. Walk east until you find the peppermint leaves. Get some peppermint.

Note: *I've encountered two different endings to this saga. The first is the easiest, but if you use it you'll miss a major portion of the game's puzzles and graphical screens.*

ENDING 1

If you've decided on Ending 1, travel to the Isle of the Crown and enter the pawn shop. Exchange the tinderbox for the mechanical nightingale. Journey to the castle. To deceive the guards, enter the little hut and change into Beauty's clothing. Save the game, then enter the castle.

Clamber up the left staircase. Wait until the guards begin walking AWAY from you, then dart into the center alcove. Quickly click the hand cursor on the pillar to avoid being spotted by the guards. After the guards have passed, enter the hallway and place the mechanical nightingale on the floor (red carpet). Again, hide behind the pillar. When the guards leave the hallway, look at the portrait. Click the hand cursor on the portrait to remove it from the nail. Get the nail. Enter the hallway and open the west door. Use the nail to pick the lock of the storage trunk. Get the letter. Look in the ebony box. Read the piece of paper:

❑ ZEBU

KING'S QUEST VI

Exit the vizier's room. Replace the nail and the portrait. Enter the hallway and walk north, then east. Talk to the north door (Cassima). To give Cassima the dagger, slip it under the door. Walk one screen west. Enter the center alcove and hide behind the pillar to avoid the guards. Go downstairs and give Captain Saladin the letter that you found in the vizier's trunk.

Enter the Throne Room. Talk to Cassima (genie). Show her the mirror. Follow the vizier. When the genie appears, offer him the peppermint. To defeat the vizier, click the hand cursor on the sword behind Alexander. Click the sword on the vizier twice. Congratulations! You've completed *KQ6*. Now play again, but this time use the spells in the magic book to win.

ENDING 2

Did you find the human skull in the catacombs? If not, travel to the Isle of the Sacred Mountain and enter the catacombs. Walk two screens north, two screens east, and one screen north. Get the human skull. Retrace your steps and carefully climb down the cliff.

Click the spell book on Alexander. *Cast* the *Make Rain* spell. Then travel to the Land of the Green Isles. After escaping the wicked flames, fill the human skull with hot embers. Travel back to the Isle of the Sacred Mountain. Scale the cliff and you'll encounter the mighty winged horse. Look at the spell book. Find the following spell:

☐ *Charming a Creature of the Night*

Place the rotten egg into the skull of embers. Next, place the strand of hair (which you found in the red ribbon) into the skull. *Cast* the spell.

REALM OF THE DEAD

Save the game. Talk to the two restless spirits wandering aimlessly among the Realm of the Dead. They'll give you a ticket to the Underworld (not to be confused with *Ultima Underworld*). Walk one screen east. Talk to the weeping spirit. She'll tell you about her lost son, then present you with a handkerchief.

Hint: *Avoid coming in contact with any spirits. If you touch them, you'll become one of them.*

To reach the entranceway to the Underworld, walk north. Save the game. Walk toward the large bones on the left side of screen (note the key the first skeleton is carrying). To get the key, click the hand cursor on the bones. The skeleton will dance to your music and drop the key. Pick up the skeleton key. Give the ticket to the uniformed skeleton. After entering the Underworld, find the body on the path. Look at the body. Get the black gauntlet. Continue along the path until you reach the River Styx. Collect some water in the teacup. Look at Charon. Give him the two coins (that you found in the catacombs) as fare for passage.

After crossing the River Styx, click the hand cursor on the wooden gate (don't get too close or you'll die). Talk to the gate. The answer to the gate's riddle was printed on the piece of paper that you found entangled in the spiderweb on the Isle of Wonder. The answer is

❑ LOVE

Save the game, then approach the Lord of the Dead. When he asks you to kiss his hand, deny his request. Talk to the Lord, then challenge him by using the gauntlet. To make the Lord cry, click the Beast's mirror of truth on him. Now, to get into the castle, you must use magic: the *Magic Paint* spell, to be exact. But first visit the pawn shop and exchange the tinderbox for the painter's brush.

Are you wondering which lantern to buy from the peddler? You can find the answer by entering the pawn shop and drinking the potion labeled

❑ DRINK ME

Exit the pawn shop and give the hunter's lamp to the street peddler in exchange for the blue lamp (second from the end). Now you can travel to the castle.

Walk to the west side of the edifice. To get into the castle, create the *Magic Paint* spell potion by placing the black horse feather into the teacup (which already contains swamp ooze and water from the River Styx). Now use the painter's brush on the side of the castle. *Cast* the spell. Save the game, then enter

KING'S QUEST VI

the castle.

Locate the dungeon where the young boy's weeping spirit is held. Talk to him. Give him the handkerchief and he'll tell you about a secret entranceway behind the man of steel (suit of armor). Leave the dungeon and walk north, then east. Pull the left arm of the suit of armor. Enter the secret passageway. Peer through the chink in the wall. Walk up the staircase. Look through the other chink in the wall and you'll see Cassima. Talk to Cassima, then offer her the dagger. Walk west (while following the secret passageway) and peer through any chinks you encounter. When you reach the end of the passageway, click the hand cursor on the vague outline of a door.

Open vizier's storage trunk with the skeleton key. Get the letter. Open the ebony box and read the note. Retrace your steps until you reach the castle's hallway. Walk west, then south. To open the door along the west wall, talk to the door. The password is

❑ ALI ZEBU

Remove the velvet drapery from the table and look at the four items. This is all you can do in this room. Exit vizier's storage room. Walk north, then two screens east. Open the door along the east wall. Talk to Jollo. Give him the lamp you received from the street peddler. Exit Jollo's room and wait patiently for the wedding music. Ascend the staircase (across from Jollo's room) and click the hand cursor on the door.

When you're confronted by Captain Saladin, give him the letter that you found in vizier's storage trunk. Enter the Throne Room and talk to Cassima (genie). Follow Alhazred. Click the lamp on Alexander BEFORE Shamir casts his spell. To defeat Alhazred, get the sword from the north wall and click it on Alhazred twice. Congratulations: You survived another award-winning saga from Sierra On-Line.



LOCATION OF OBJECTS

- Baby's Tears Isle of Wonder
- Bargain Book Book Shop (Isle of the Crown)
- Beast's Ring Isle of the Beast
- Beauty's Clothing Isle of the Beast
- Black Horse Hair Isle of the Sacred Mountain
- Brick Isle of the Beast
- Copper Coin Beach (Isle of the Crown)
- Dagger Lady Celeste (Catacombs)
- Drink Me Potion Isle of the Crown
- Flower Isle of the Sacred Mountain
- Flute Pawn Shop (Isle of the Crown)
- Flying Water Isle of the Beast
- Gauntlet Body (Underworld)
- Genie Lamp (replica) Street Peddler (Isle of the Crown)
- Gold Coins Catacombs (Isle/Sacred Mountain)
- Handkerchief Realm of the Dead
- Head of Lettuce Isle of Wonder
- Hole in the Wall Isle of Wonder
- Hunter's Lamp Isle of the Beast
- Incomplete Sentence Beach (Isle of Wonder)
- Invisible Ink Pot Outside Pawn Shop (Crown)
- Letter Vizier's Trunk (Castle)
- Love Poem Book Shop (Isle of the Crown)
- Lump of Coal Land of the Green Isles
- Magic Map Pawn Shop (Isle of the Crown)
- Mechanical Nightingale Pawn Shop (Isle of the Crown)
- Milkweed Isle of Wonder
- Mint Pawn Shop (Isle of the Crown)
- Mirror Isle of the Beast
- Nail Castle (Isle of the Crown)
- Note from Cassima Sing Sing (Isle of the Crown)
- Odd Creature Isle of the Beast

KING'S QUEST VI

- Painter's Brush Pawn Shop (Isle of the Crown)
- Pearl Oyster (Isle of Wonder)
- Peppermint Leaves Cave (Isle of the Sacred Mountain)
- Piece of Paper Spiderweb (Isle of Wonder)
- Rabbit's Foot Ship's Cabin (Isle of the Crown)
- Rare Book Caterpillar (Isle of Wonder)
- Red Ribbon Sing Sing (Isle of the Crown)
- Red Scarf Queen (Isle of Wonder)
- Royal Insignia Ring Beach (Isle of the Crown)
- Sacred Water Oracle (Isle/Sacred Mountain)
- Scythe Land of the Green Isles
- Skeleton Key Realm of the Dead
- Skull Catacombs (Isle/Sacred Mountain)
- Spell Book Bookstore (Isle of the Crown)
- Spoiled Egg Queen (Isle of Wonder)
- Strand of Hair Red Ribbon (Sing Sing)
- Swamp Ooze Isle of Wonder
- Sword Castle (Isle of the Crown)
- Teacup Isle of Wonder
- Ticket to Underworld Realm of the Dead
- Tinderbox Pawn Shop (Isle of the Crown)
- Tomato (rotten) Isle of Wonder
- Water from River Styx Underworld
- White Rose Isle of the Beast
- Wooden Shield Catacombs (Isle/Sacred Mountain)

MAPS

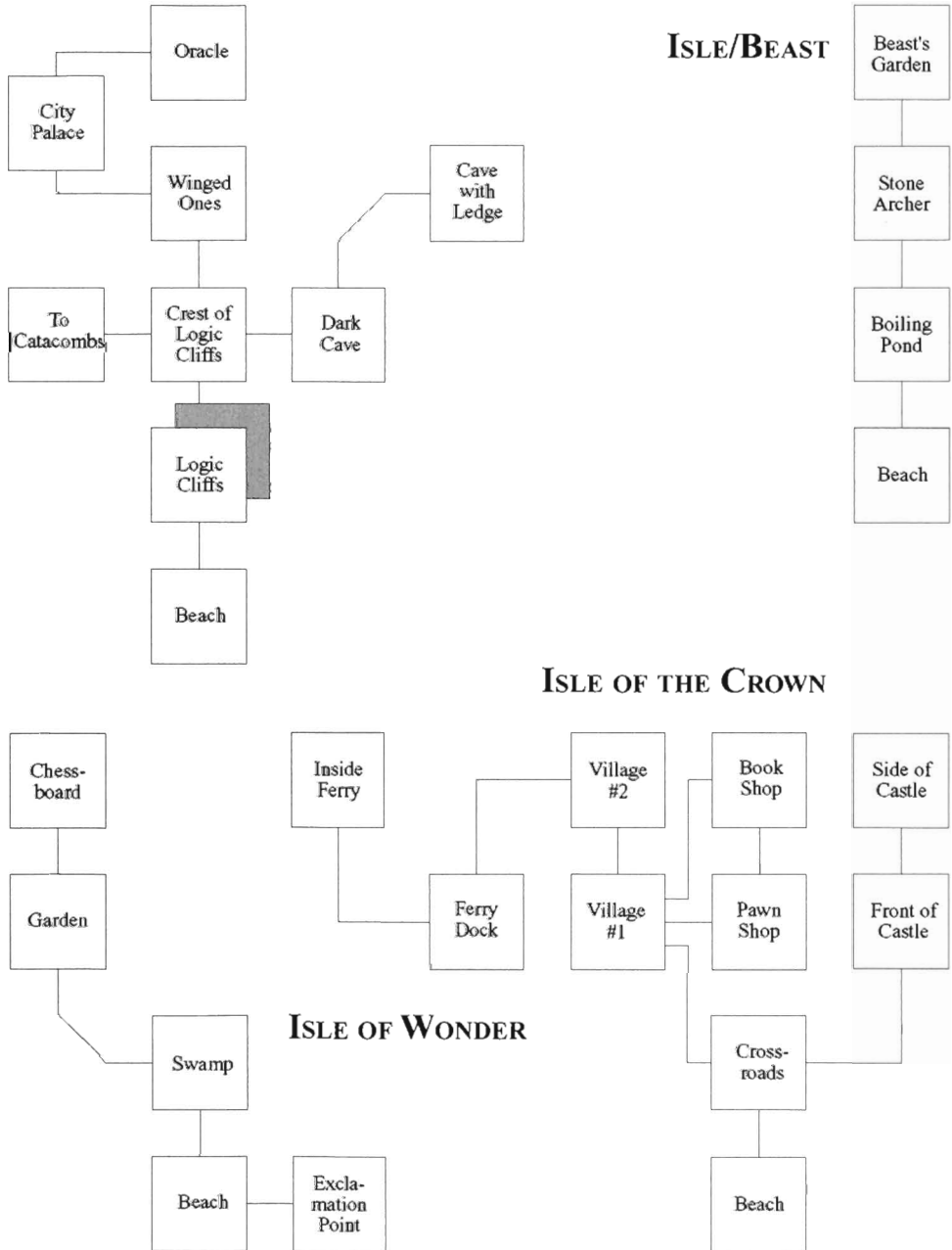

KING'S QUEST VI

CATACOMBS LEVEL 1

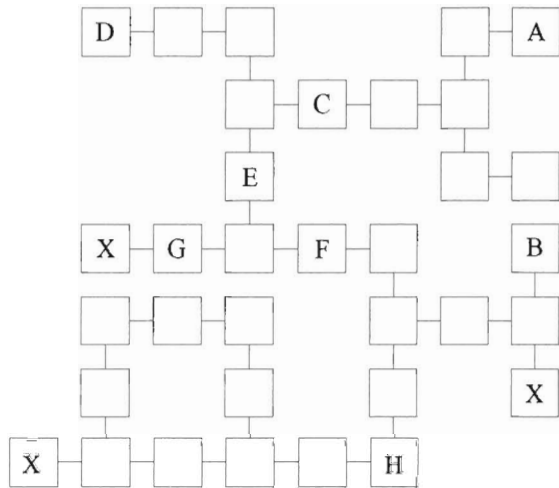

- A= Pit to Level 2
- B= Skulls
- C= Ceiling Trap
- D= Deadman's Coins
- E= Shield
- F= Spike Maze
- G= Genie (Lady Celeste)
- H= Start
- X= Death

CATACOMBS LEVEL 2

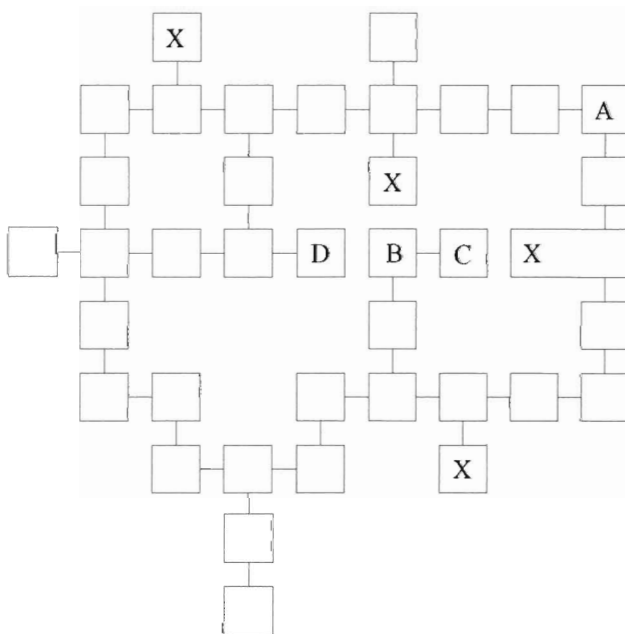

- A= Start
- B= Lair Entrance
- C= Minotaur's Lair
- D= Spy Room
- X= Death

SPIKE MAZE

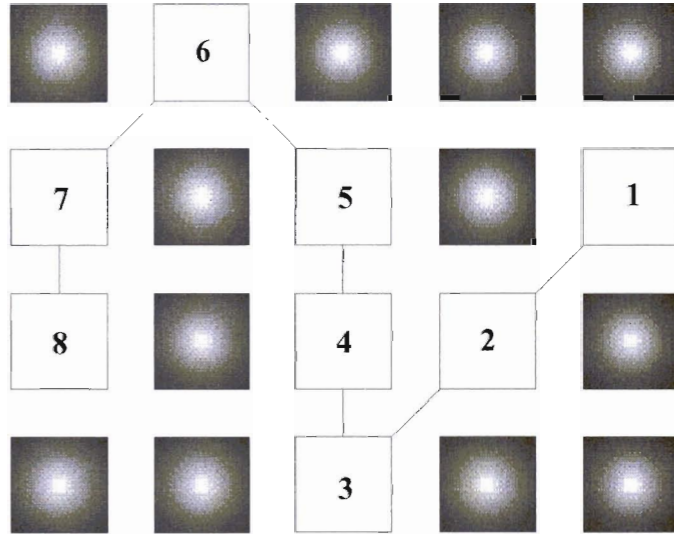

CASTLE OF THE CROWN
(BASEMENT)

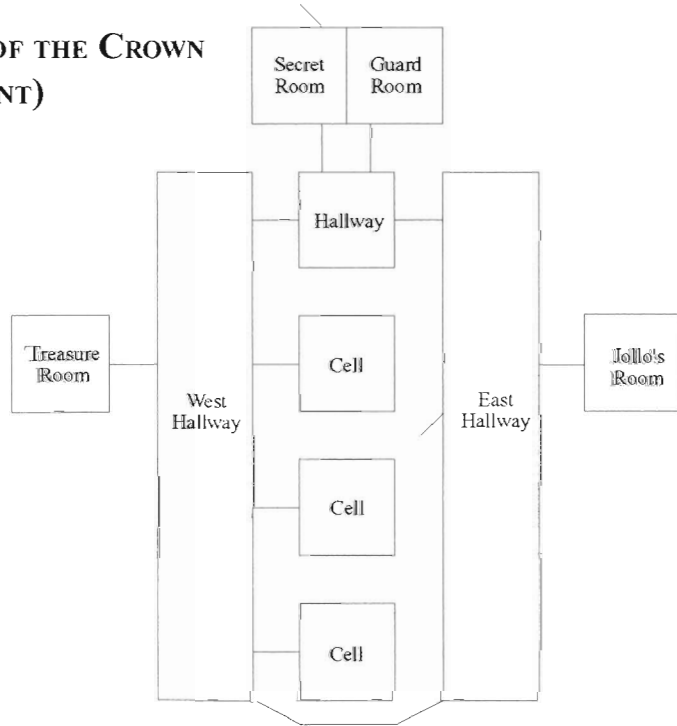

**CASTLE OF THE CROWN
(MAIN FLOOR)**

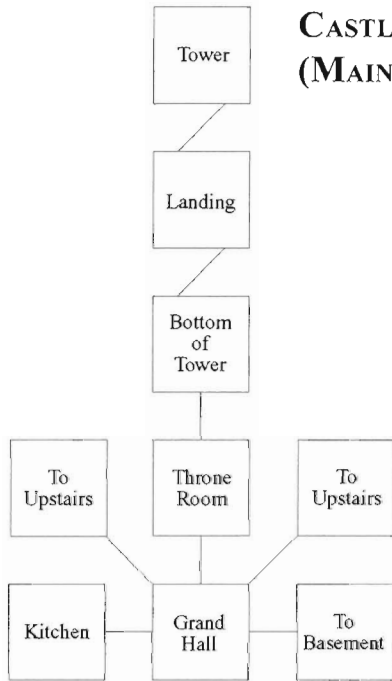

**CASTLE OF THE CROWN
(SECOND FLOOR)**

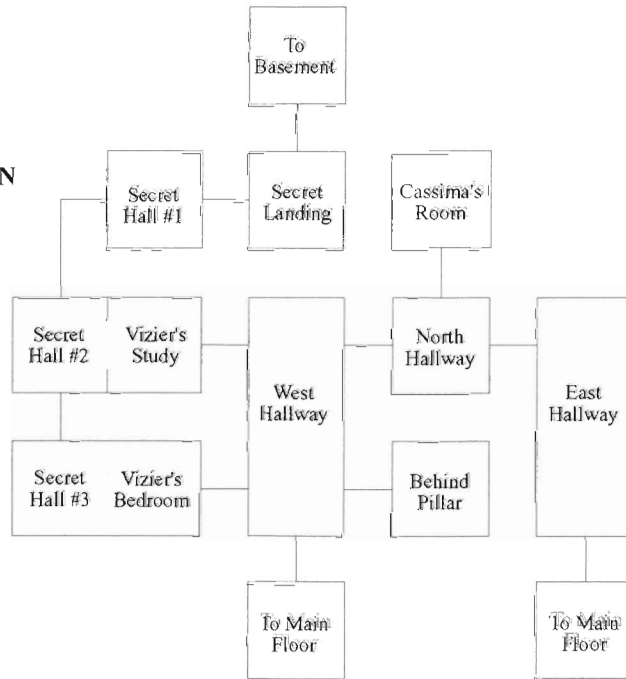

CHAPTER 13

LES MANLEY IN: LOST IN L.A.

GRAPHICS: ☆☆☆

STORY LINE: ☆☆☆

ARCADE: N/A

INTERFACE: ☆☆☆

DIALOGUE: ☆☆☆

AUDIO: ☆☆☆

ANIMATION: ☆☆☆

LENGTH: ☆☆☆

OVERALL ANALYSIS: ☆☆☆

SYSTEMS

- MS-DOS IBM-PC/Tandy & Compatibles

FEATURES

- 256-color VGA.
- Live video footage of real actors and actresses.
- Cool animation and character scaling.
- Real Southern California locations.
- Rockin' L.A. soundtrack with total music and sound support.



SCENARIO

Les Manley in: Lost in L.A., designed by Steve Cartwright of Accolade, takes place in the heart of Southern California. You assume the role of a nerdy looking fellow named Les "The Chutzpa" Manley who has been invited to California by his

friend Helmut Bean (the smallest man in the world). But when Les arrives, Bean is nowhere to be found. Eventually Les learns that someone is kidnapping the hippest celebrities in Hollywood. As Les, you must comb the sands of Venice Beach, scour the streets of Sunset and Vine, intermingle with yuppies on Hollywood Boulevard, and flirt with luscious California babes in your search for the Beanster. During your journey, you'll see actual digitized pictures of real people (some of whom appeared in *Playboy*) and bit-map graphics to enhance viewing pleasure. Only the close-up views are of digitized characters, however; the overall view is still the conventional handpainted backgrounds, using oils on canvas. The interface is almost too easy: Accolade has chosen to place the icon menu at the bottom of the screen (instead of the more commonly used top-screen menu bar as in Sierra games). In addition, this interface changes the cursor for you automatically—eliminating the need to cycle through half-a-dozen cursors. Let's go: It's time to join Les Manley and meet some gorgeous California babes, out-of-work actors, and headstrong rock stars as you seek Helmut Bean.



WALK-THROUGH

ACT 1: VENICE BEACH

Welcome to Venice Beach, California. Begin your quest by walking one screen west. Find the newsbox and open it. Read the newspaper. Walk one screen west and you'll find Lance the lifeguard. Talk to Lance using response No. 1. After a meaningless conversation, use the response regarding the eclipse. When the eclipse occurs, grab Lance's bandanna. Then Lance will suggest that you speak to the female weight lifters. To find them (from the beach), walk two screens east and one screen south. Talk to the shapely women. Get as much information from them as possible. Eventually, they'll suggest that you talk to their friend Rock, the cop. To find Rock, walk one screen east. When you see the full-screen map, click on Hollywood Boulevard. From the wax museum, walk west. There you'll encounter Rock directing invisible traffic. Begin the conversation with the following response:



Is your name Rock?

Use the appropriate responses thereafter. Locate the tourists Eb and Clora (they're standing on the southwest corner of the intersection). Talk to them. Eventually, they'll realize that you know Helmut Bean, which makes your autograph a worthy prize. Use the response that begins



Sure ...

The tourists will give you a map identical to the one you already have. From the intersection, walk one screen east and one screen south. Click on Sunset and Vine.

SUNSET AND VINE

After arriving at Sunset and Vine, walk one screen east. Talk to the peddler standing in the alleyway. Give him the map (which you received from the tourists). In return, he'll give you a cellular phone. To get to the map screen, walk east. Travel to Rodeo Drive.

RODEO DRIVE

Locate the bird in the bush. Click the question-mark cursor on it and it will poop on the windshield of the sports car. Use your handy K mart credit card to scrape up the bird droppings. Travel west until you get to the map screen, then click on Hollywood Boulevard.

PEACECHILD AND THE PHOTO BOOTH

From the wax museum, walk east. Standing on the corner you'll see Blade. Talk to him. Give him the cellular phone (which you received from the peddler). Ask Blade to give you the password for the LAPD database. Walk across the street and enter Murry's Hotel. Talk to Murry. Ask him about Blade and you'll find out that Blade's real name is Peacechild (tee-hee). Look under Murry's arm when he shows you the way out. Did you see the ticket? Reenter the hotel. Ask Murry about the ticket. Be persistent and he'll give it to you, along with a film cartridge. Exit the hotel. Talk to Blade—I mean Peacechild. He'll tell you about The Boyz.



After conversing with Peacechild, walk south and you'll arrive at Club Mud. Talk to Bob The Barker. Give him the ticket Murry gave you. Unfortunately, the show is full and you'll need to return later. From Club Mud, walk east. Click on Hollywood Boulevard. From the wax museum, walk west. Enter the purple photo booth located behind Rock. Give the beautiful clerk (Rainbow) the film. Get

your picture taken with

❑ Lafonda Turner

Exit the photo booth. Feel free to enter the photo booth anytime during game play: Rainbow sure is easy on the eyes.

LOU'S PAWN EMPORIUM

Walk south until you reach Lou's Pawn Emporium. Who's that blocking the entranceway? Why, it's The Boyz. Do you remember what Peacechild told you about The Boyz? They aren't as tough as they look. Talk to them. Ask about all. Give them the bandanna. Enter the pawn shop. Look at the computer on the top shelf. Talk to Lou and you'll realize that he isn't very smart—and he doesn't even know what a computer is. Since you don't have any money, you'll need to exchange something for the computer. Lou is a big fan of Lafonda Turner. And you just happen to have a photograph of her. Lou will gladly trade the computer for the picture.

THE MUD WRESTLING SHOW

Are you ready for the mud wrestling show? I hope so, because it's time to hustle on over there. Do you remember how to get there? From the pawn shop, walk east until you see Peacechild, then travel south. Give Bob the ticket. Save the game before the show (you may want to watch it twice). After the show, you'll find yourself in a hotel room. Ask the young women for a DOS disk. To your surprise, they'll have one. Get the diskette. Boot up the computer, then hack away by using the password Blade gave you:



❑ Elvis

After gaining access into the LAPD database, travel to Paramounds Studio. To get there from Murry's Hotel, travel east. Click on Paramounds Studio.

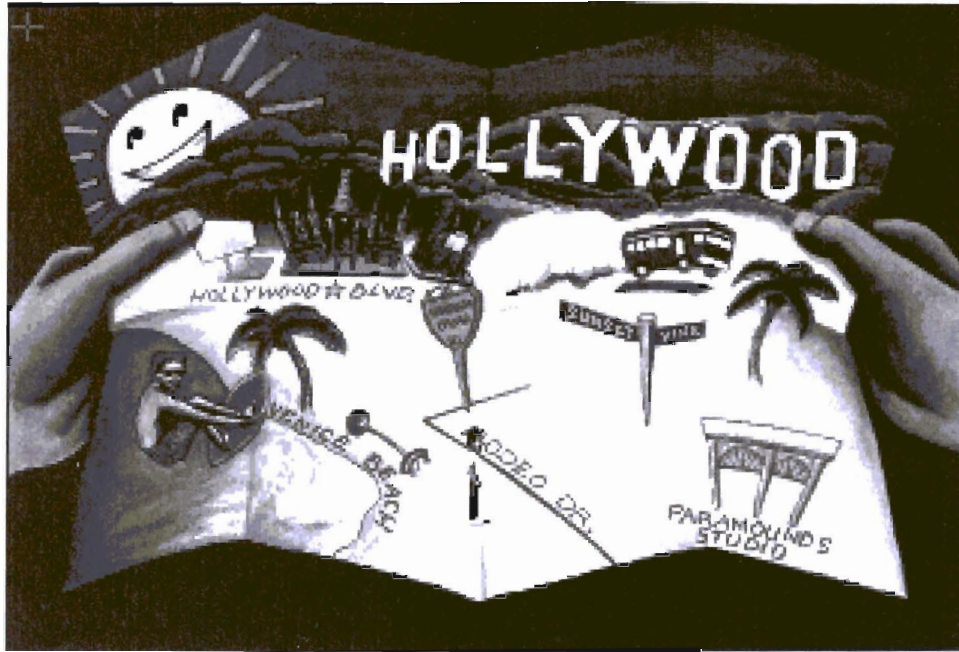

PARAMOUNTS STUDIO

When you reach the studio, you'll be stopped by a guard. Talk to him. Tell him that you must see Maladonna. If you sound convincing, he'll allow you entry. After passing the copy-protection sequence, enter the second stage door on the right. Look at the rowboat. If you take a closer look, you'll notice a tiny hole in the hull. Plug the hole with the bird droppings that you found at Rodeo Drive. Once the hole is plugged, climb into the rowboat. When you reach Camp Blood, open the cabin door. Oh no—you just infuriated Jason Myers. Well, try talking to him using the following response:

☐ *Freddy's scarier*

That will really make Jason mad—mad enough to chop you in half. Don't worry, you didn't die; it was only a special effect. Did you notice the secret door where the producer briefly appeared? That's your escape route. Before leaving, take Jason's axe.

ACT 2: THE PORTFOLIO

Begin the second act by traveling to Sunset and Vine. Enter Tony Leoni's Agency. Tell him that you're inquiring about an agent. He'll tell you that without a portfolio you'll never get an agent. Leave Tony's office and walk east (down Vine Avenue). Enter Luther Blue Studios. He'll be disgusted by your appearance and suggest plastic surgery (gulp). Just what you need, an *ugly* photographer telling *you* to get a face-lift. What's next, new clothing? Travel to Rodeo Drive. Directly across from the red sports car is Dr. Nick Nikopoulos's office. Enter Les Plastique. Look at the pictures of the stars who had major work done (or undone, whatever the case may be). Talk to the doctor. Use the following responses:

- Luther...*
- Are there any options?*

After receiving your new nose, travel to Sunset and Vine. Get your portfolio from Luther the photographer. Visit Tony. He'll tell you that you need new clothing (grunt). Travel to Rodeo Drive. From the scene with the sports car, walk one screen east. Enter Les Boutique. Talk to the clerk. Tell her you just want to look around. Walk over to the rack of clothes and Maladonna will enter the store. Listen closely to what she says. After a short animated sequence, you'll find yourself doing lunch with Abe Goldstein. Talk to Abe, but *do not* accept his offer. If you do, the game will end. After denying his offer, you'll be invited to the Hollywood party. At the party, move the cursor around the screen until you locate Abe, Les, and Maladonna. Accuse either of them of the crime and they'll begin to argue. After a very lengthy argument, follow the white limousine to the Hollywood Wax Museum. Save the game.

ACT 3: THE HOLLYWOOD WAX MUSEUM

The climax of the game takes place in the Hollywood Wax Museum. Open the door using Jason's axe. Walk east. Get the torch. Locate the two waxy women. Use the hand cursor on either woman and some wax will rub off on your fingertips. Find Helmut—his display is just to the right of the wax women. Place the torch next to Helmut.

Hint: *You must place the torch next to Helmut BEFORE looking at him.*

After a short animated sequence, game control will change to Helmut. As Helmut, you must save Les from the evil Mad Wax. Begin by taking the torch. Walk to the west end of the museum. Use the torch to melt Conan's grip around the sword. Get the sword. Cut the loincloth off Tarzan. Travel back to Helmut's display stand. Scrape off some wax using the sword. Click the wax on the Alien's acid drool. Helmut will automatically shape the wax into a cup in which to hold the acid. Walk one screen west. Locate the Sarcophagus (west of the organ). Use the sword to pry it open. Enter the secret room. Use the loincloth as a parachute. Float down to the lower level. Use the acid drool to melt the restraining metal straps. Game control will now return to Les. When the Killer Zombie Bimbos appear, click the K mart credit card on them. The next scene will be of the bell tower. Open the trap door. When talking to Mad Wax, use the following response:

❑ *Let's cut a deal*

Use the K mart credit card on Mad Wax. He'll produce a gun. Click on the bell rope and Helmut will free himself. Before he pulls the rope, place the wax in Les's ears to protect them from the loud gong of the bell. When the bell rings, Mad Wax will drop the weapon. Attempt to get the gun. Helmut will position himself behind Mad Wax.



Use the hand cursor to push Mad Wax into the atrium of the Bell tower and he'll tumble to his death.

LOCATION OF OBJECTS

- Acid Drool Alien (Wax Museum)
- Axe Camp Blood
- Bandanna Lance (Venice Beach)
- Bird Droppings Windshield of Sports Car
- Cellular Phone Peddler (Sunset and Vine)
- Club Mud Ticket Murry
- Computer Lou's Pawn Emporium
- DOS Diskette Women in Hotel Room
- Film Cartridge Murry
- Loincloth Wax Museum
- Map Tourists (Hollywood Boulevard)
- Newspaper Venice Beach
- Nose Les Plastique
- Photograph Purple Photo Booth
- Portfolio Luther Blue Studios
- Sword Wax Museum
- Torch Wax Museum
- Wax Women (Wax Museum)

MAPS

RODEO DRIVE

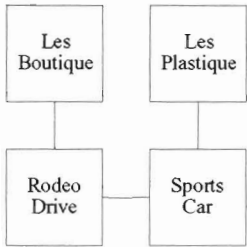

SUNSET & VINE

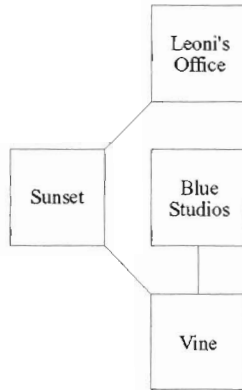

VENICE BEACH

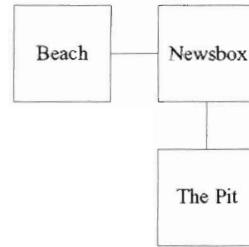

HOLLYWOOD BLVD.

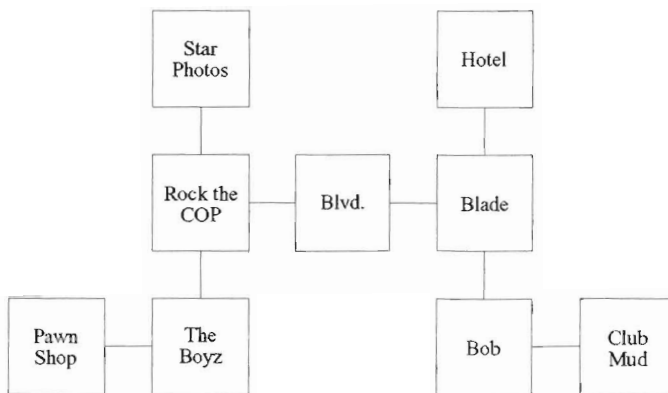

WAX MUSEUM

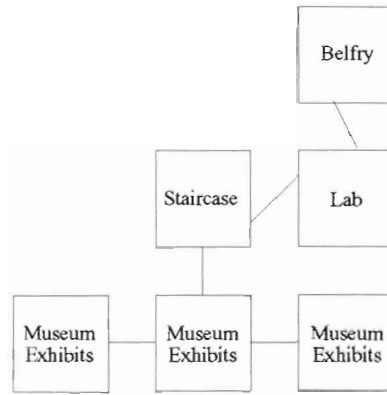

PARAMOUNDS STUDIO

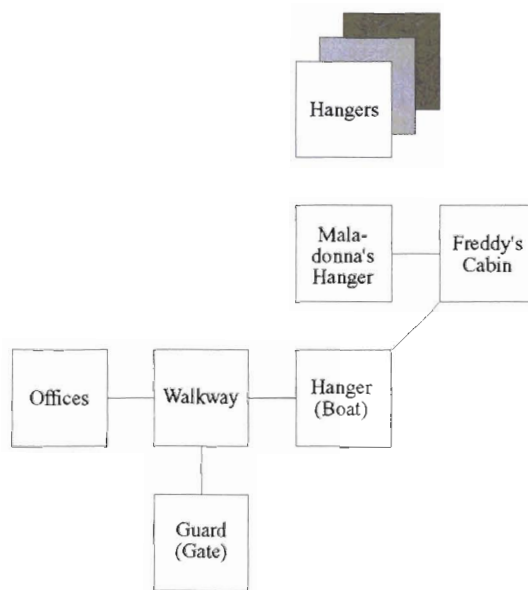

CHAPTER 14

QUEST FOR GLORY III

GRAPHICS:	☆☆☆☆	STORY LINE:	☆
ARCADE:	☆☆	INTERFACE:	☆☆☆☆
DIALOGUE:	☆	AUDIO:	☆☆
ANIMATION:	☆☆☆	LENGTH:	☆☆
OVERALL ANALYSIS: ☆☆☆			

SYSTEMS

- MS-DOS IBM-PC/Tandy & Compatibles

FEATURES

- Hand-painted, digitized art.*
- Video-captured animation.*
- Multiple solutions depending on character abilities.*
- No-typing interface.*
- Full music-card support.*
- Sophisticated conversation and combat systems.*
- Start fresh or import your hero from Quest for Glory I or II.*
- No prior experience with Quest for Glory needed.*
- Choose your character type and modify his skills and talents.*
- Every decision you make builds your Hero . . . and shapes your destiny.*
- Overcome obstacles with might, magic, and cunning.*



SCENARIO

From creators Lori and Corey Cole of Sierra On-Line comes another saga in the *Quest for Glory* series: *Wages of War*. Team up with Uhura and Rakeesh the Liontaur as you try to cut to the core of the evil that's reaching to the very heart of fear itself. *QG3* allows you to import your character from the earlier chapters. This allows you to begin the game with a slight character advantage. If you've never experienced *Quest for Glory* before, you're probably not aware of the fact that you can choose to play as a fearless fighter, a

wily thief, or a mysterious magician. Each calling will lead you down an individualized plot branch where the path varies, requiring different solutions to solve the game. Combining character-building, physical combat, and magic with Sierra's unparalleled flare for style, *Wages of War* is one adventure/role-playing game that should be conquered by every gaming enthusiast.

WALK-THROUGH

TARNA

Speak with Rakeesh by clicking the talk cursor on your character, then on Rakeesh. Ask him about all. Talk to Kreesha and ask her about all. Exit the magic workroom by walking west, then north. Examine inventory. Look at the note and remember the name of the addressee.

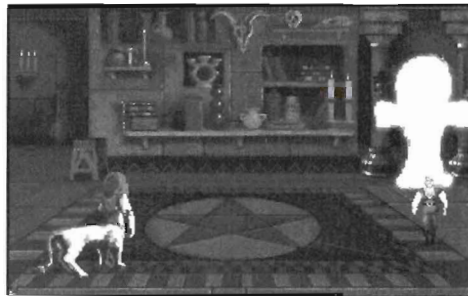

BAZAAR

Before you can purchase any items in the bazaar, you'll need to exchange your currency for Dinars (Royals are not welcome in Tarna). From the entrance to the magic workroom, walk two screens west. There you'll witness a dispute. Walk east and you'll be summoned to the Hall of Judgment. Once there, talk to Rajah. Ask about all. After the judgment, enter the Temple of Sekhmet (highest of all doors). Walk to the center of the room. Attempt to exit the Temple and the statue will order you to find the Gem of the Guardian. Travel to the bazaar by walking two screens west of the Temple of Sekhmet.

Approach the money changer. Greet him by clicking the talk cursor on your character. Talk to the money changer. Ask about all. Exchange your Dinars for Royals. Just north of the money changer is the leather worker. Greet him and ask about all. Purchase five zebra skins and a waterskin by either clicking the talk cursor on your character or by clicking the money pouch on the merchant. Walk one screen south. Talk to the weapons seller. Purchase a fine spear and a fine dagger. Talk to the junk dealers, Pop and Dummy. Purchase a tinder box. Directly south of the junk dealers is the honey merchant.

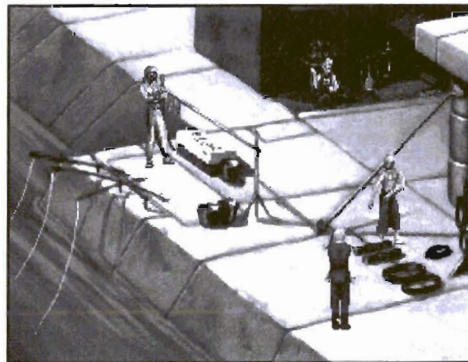

Talk to him. Ask about all. Purchase a flask of honey. Now walk one screen south. Talk to the lady peddling beads. Purchase a string of beads. Walk one screen south. Talk to the catlike creature. Ask Shallah about all. Give her the note from inventory. Click the money pouch on Shallah and she'll give you a wood carving. Find the meat seller. Talk to him. Purchase some meat. Be sure to bargain with the meat seller, as he WILL go down in price. Locate the merchant selling clothing. Talk to her and purchase a fine robe. Exit the bazaar. Enter the Apothecary. Have a seat on the cushion. Talk to Salim Nafs. Ask about all. Attempt to purchase the Dispel potion and Salim will tell you that he needs the following ingredients:

- Water from the Pool of Peace
- Gift from the Heart of the World
- Fruit from a venomous vine

Purchase a bottle of cure pills and a bottle of healing pills. Exit the Apothecary. Enter Kreesha's magic workroom. Talk to her. Ask about all. Exit the workroom and enter the Welcome Inn (west building). Sit at a table, then talk to the Welcome Woman. If you think she's attractive, you can flirt with her by clicking the talk cursor on your character, then on the flirt icon. Order a meal. Before going to your room, look at the advertisement board along the north wall. Enter your room via the staircase and sleep the night away. Come next morning, save the game and search the Savanna for venomous vines.



VENOMOUS VINES

Before exploring the Savanna, have a meal at the Welcome Inn (this saves on food rations). If you have cure pills, you can exit the Inn and leave Tarna by walking one screen east (past the magic workroom). Talk to the Liontaur guards.

QUEST FOR GLORY III

Ask about all, then leave Tarna.

Hint: *If nightfall approaches, you must camp for the night. While viewing the map screen, click on the sleep cursor and select the appropriate dialogue responses. Always make a campfire using the tinder box on the pile of firewood. This will keep away the night creatures. Come next morning, be sure to extinguish the campfire by clicking the hand cursor on it.*

Use the eye cursor to locate the interesting-looking rock formation (southeast quadrant of map). Travel there and walk into the vines. Brandish your sword to hack your way free. Walk one screen north, then travel back to the rock formation. Wait until a meerbat gets entangled in the vines. Walk into the vines. Use the sword on the vines. Exit this screen, then return for a third time. Get the fruit and the glowing gem from the ring of stones the meerbat created. Now eat some poison cure pills from the blue bottle (you purchased them from the Apothecary).

Hint: *Eat some poison cure pills.*

Travel to Tarna for the meeting of judgment. If you don't make in time, don't despair—you'll travel there automatically.

THE JUDGMENT

When it comes time for the meeting of judgment, travel to Tarna. When the dialogue selection box appears, choose *Yes*. Now you'll travel to the Simbani Village. Once there, save the game.



POOL OF PEACE

After your journey to the Simbani village, exit the hut and leave the village by walking south. Walk to the small lake (Pool of Peace).

Note: Be sure to slay any creatures you encounter along the way. Also, search their bodies after defeating them.

Drink some water from the pool. Click the waterskin on the pool. Pet the cheetah. Leave the Pool of Peace and travel to the big tree (east).

THE BIG TREE



Find the path at the foot of the big tree. Follow this path until you reach the cavern (east of the waterfall). When the glowing sphere covers your body, click the talk cursor on your character. Ask about *Gift* and *Gem*. Take only one (1) beryl. If you take more than one, the game will end. Leave the cave and follow the path up the tree.

Enter the cave just above the waterfall. Look at the spiral platform. Place the waterskin (filled with water from the Pool of Peace) on the platform and you'll obtain the Gift from the Heart of the World (the final ingredient to make the dispel potion). Travel back to the Pool of Peace and refill the waterskin. Check the game time. If it's getting late, sleep at the Pool of Peace for the night. Travel to Tarna and give the Dispel potion ingredients to the Apothecary:

- Magic water from the Pool of Peace
- Gift from the Heart of the World
- Venomous vine fruit

Unfortunately, it will take him a while to make the Dispel potion. Therefore, exit

QUEST FOR GLORY III

the Apothecary, save the game, and enter the Temple of Sekhmet.

TEMPLE OF SEKHMET

Are you ready to be judged? If you received the Gem of the Guardian from the orb at the big tree, you can enter the Temple of Sekhmet. Save the game prior to entering the Temple. Choose the following items and responses:

- Sword
- 4
- Yin-Yang symbol
- 1
- Ring
- 2



Exit the Temple and have a meal at the Welcome Inn. Sleep there for the night. Come next morning, purchase a meal and get the Dispel potion from the Apothecary. Now check your food rations, then travel to the Simbani Village.

THE SIMBANI VILLAGE

After arriving at the village, walk east and you'll see the wrestling bridge. Click the hand cursor on the wooden cross-beam. Click the hand cursor on the rope to climb onto the wrestling bridge. When Uhura appears, ask about all. Again, click on the rope. Do this over and over until you finally make it across. If nightfall arrives before you make it across the wrestling bridge, get some rest and try again in the morning. After making it across the wrestling bridge, walk two screens west. Click on the spears. To test your skill at spear-throwing, click the spear point on the bull's-eye. Go back to the wrestling bridge and practice some more.

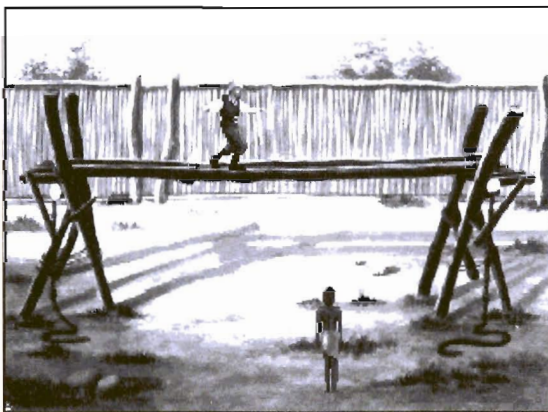

Hint: Talk to Laibon (center hut) sometime during your stay at the Simbani Village. Just don't touch that drum!

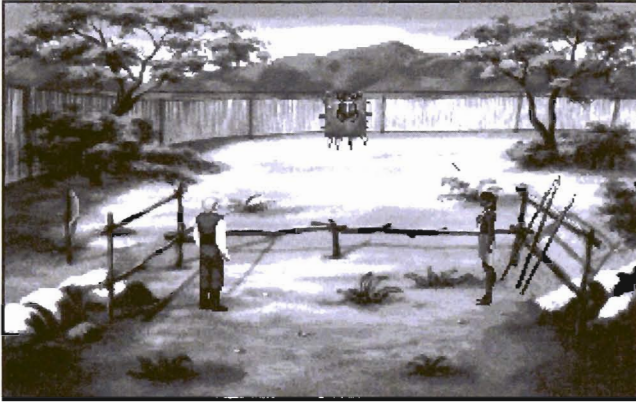

After you get bored with spear-throwing and the wrestling bridge, you can play the game of Awari. From the center of the village, walk north. Click on the Awari game board and follow the onscreen instructions. Now go back to the wrestling bridge and practice until Uhura

offers to give you a lesson. Accept her offer by clicking the talk cursor on your character. Then practice spear-throwing until Uhura offers her assistance. Only after you've defeated Uhura on the wrestling bridge and at spear-throwing will the game progress. Plan on spending a lot of time trying to complete this annoying, time-consuming sequence. After accepting Uhura's challenge (at spear-throwing), walk to the cage by the Awari game. Notice the prisoner. Look at the Leopardman in the cage. Attempt to talk to the prisoner. Talk to the guard. Use the Dispel potion on the prisoner to repel the evil curse. Look at the attractive young woman (prisoner).

Have you slain a dinosaur yet? If so, did you take his horn? If you have the animal's bony outgrowth, talk to Laibon: Tell him about the dinosaur by clicking the talk cursor on your character. If you don't have a dinosaur horn, leave Simbani and venture throughout the Savanna in search of a dinosaur.

SIMBANI INITIATION

The contest begins after you give the dinosaur horn to Laibon. You can't defeat your opponent at the running contest, but you can outsmart him at the other events.

QUEST FOR GLORY III

TWISTED TREE PUZZLE

After Yesufu retrieves the ring, DO NOT repeat his technique. Instead, grab the vine from the tree. Tie the vine onto a spear. Throw the spear at the ring and retrieve it by pulling on the vine.

THORN RING PUZZLE AND THE CONTEST CLIMAX

Again, you must outwit Yesufu. Did you notice the log lying near the thorns? Click the hand cursor on the log and it will roll over the thorns. Click the hand cursor on the log a second time to enter the circle. Pick up the ring.

As you hustle to the finish line, Yesufu will get his leg stuck in a deep hole. When this happens, you have the option to help him or continue on with the race alone. I strongly suggest clicking the hand cursor on Yesufu to help him. Save the game before the spear-throwing contest. Do your best to defeat Yesufu. If you lose, restore the game and try again. The wrestling bridge contest happens automatically, so sit back and enjoy. After winning the contest, you'll enter Laibon's hut. When Laibon expects a reply from you, ask him to hold a peace conference.

Hint: Ask Laibon to hold a peace conference.

THE PRISONER

After winning the Simbani initiation, you must purchase the prisoner. Begin by reentering Laibon's hut. Tell him about the prisoner. Ask him what the bride price is:

- 1 fine robe
- 1 fine spear
- 5 zebra skins



Being the faithful reader that you are, you already have these items in inventory. If not, travel to Tarna and purchase them. With the bride price items in hand, enter Laibon's hut and click the zebra skins on him. Exit his hut and visit the prisoner. Talk to Uhura. Ask her about the gifts. Walk south, then walk back to where the

prisoner's being held. Give your wife (prisoner) the following items:

- Wooden leopard
- String of beads
- Fine dagger

Open the cage and say goodbye to your new wife as she disappears into the Savanna. Not to worry—you'll meet up with her later in the game.

THE MAGIC VILLAGE

After freeing the prisoner, leave the Simbani Village and travel to the jungle (east). Sometime during your journey through the dark jungle you'll sense someone watching you. After receiving this dialogue window, click the talk cursor on your character and choose:

- Call Out*

After Johari appears, tell her that you want to be friends. Then tell her about the magic drum. Ask her about everything and she'll escort you to her village. After reaching the Magic Village, click the hand cursor on Johari twice. Enjoy the Change ritual. When given a chance, give the Drum of Magic to Johari's father. When it's your turn to speak, tell him about peace. In return, he'll give you the Sword of Death.

THE MONKEY VILLAGE

Leave the Simbani Village and travel to the jungle (east). Since the village is more than a one day's journey, you must set up camp for the night. When you do, you'll have the pleasure of meeting an earth pig. Talk to him. Ask about all. To get rid of Arne, tell him *goodbye*. Continue combing the jungle. Eventually, you'll encounter the monkey known as Manu. Talk to Manu. Ask about all—especially the *village*. Agree to his request (he'll help you find the Lost Village). Upon your arrival, you must figure out a way to climb the tree. Talk to Manu. Ask about all. Ask Manu about the *swingline* and he'll toss it to you. Once you're in the Monkey Village, talk to Manu again. Ask about the Lost City. Then click on the following responses:

QUEST FOR GLORY III

- Convince Manu*
- Persuade Manu*
- Argue with Manu*
- Beg Manu*

To cross the waterfall, pick up the vine behind Manu. Tell Manu about the Vine Rope.

THE LOST CITY

Save the game. Leave Tarna and travel east. Talk to Manu, then enter the village. Locate the relief carving of the Egyptian god, Anubis. Place the Fire Opal in the eye of the carving. Enter the opening. Slide the *Skill* lever to its lowest position. Click the hand cursor on the far door. Defeat the Demon. Enter the back room. Defeat the Liontaur. Do your best to defeat your demon counterpart. After defeating the stone gargoyle, throw the Spear of Death at the Demon Wizard. Click the hand cursor on the stone gargoyle. Use the gargoyle as a bridge. DO NOT touch the orb or you'll die. Push the orb with your shield.

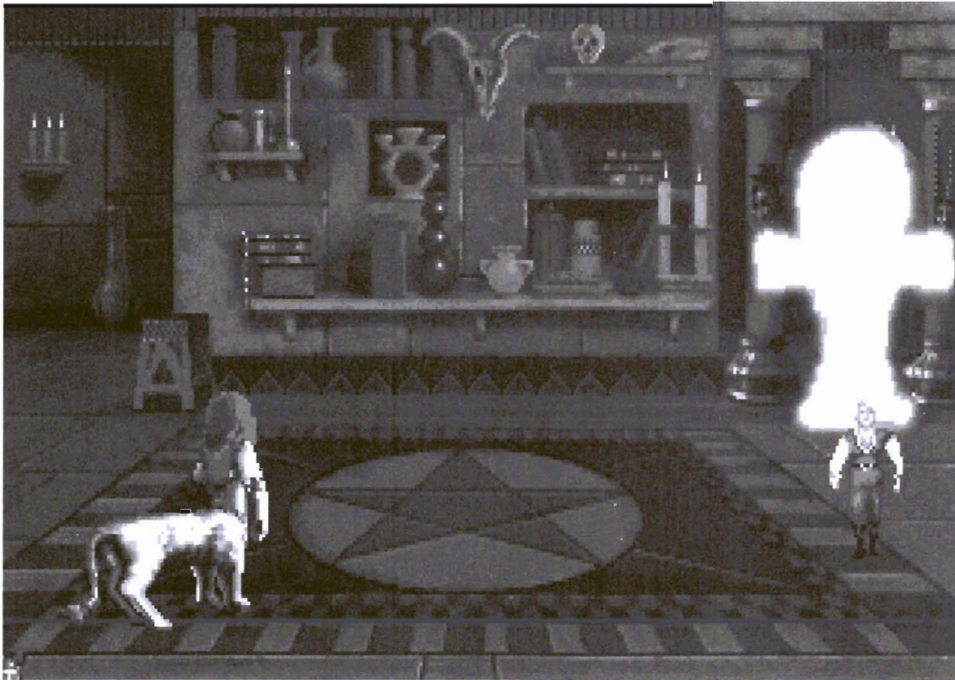

LOCATION OF OBJECTS

- Cure Pills Apothecary
- Dinars Already in Inventory
- Dispel Potion Apothecary
- Drum of Magic Laibon
- Fine Dagger Weapons Seller
- Fine Robe Cloth Merchant
- Fine Spear Weapons Seller
- Flask of Honey Honey Merchant
- Food Rations Meat Seller
- Glowing Gem Savanna (Meerbat)
- Healing Pills Apothecary
- Horn Dinosaur (Savanna)
- Magic Gem Cave (Heart of the World)
- Note Already in Inventory
- Royals Money Changer
- Shield Already in Inventory
- String of Beads Bead Merchant
- Sword Already in Inventory
- Sword of Death Johari's Father
- Tinderbox Junk Dealers
- Venomous Vine Fruit Savanna (Meerbat)
- Waterskin Leather Worker
- Wood Carving Shallah
- Zebra Skins Leather Worker

MAPS

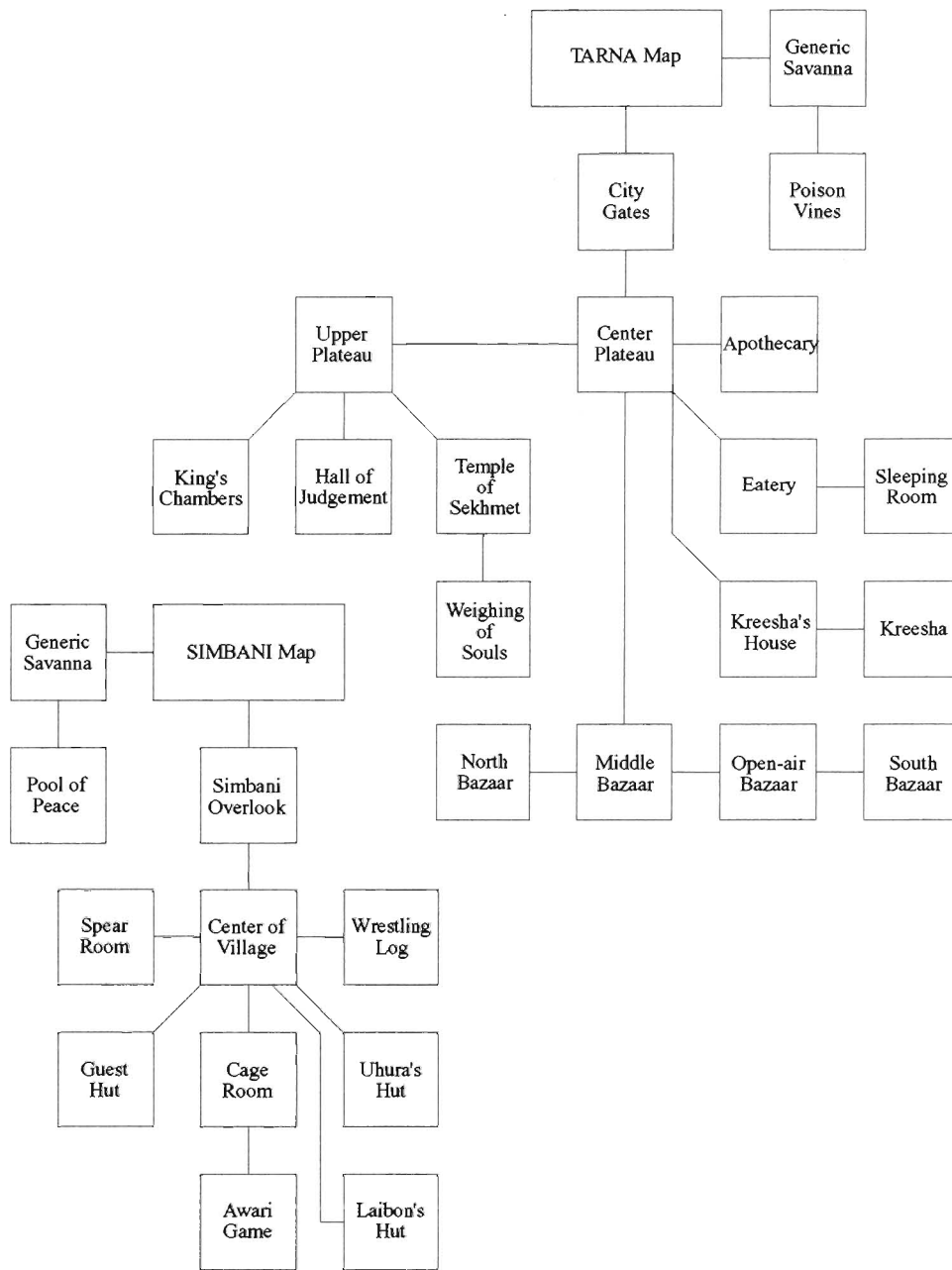

CHAPTER 15

MARTIAN MEMORANDUM

GRAPHICS:	☆☆☆	STORY LINE:	☆☆
ARCADE:	N/A	INTERFACE:	☆☆
DIALOGUE:	☆☆	AUDIO:	☆☆☆
ANIMATION:	☆☆	LENGTH:	☆☆☆
OVERALL ANALYSIS: ☆☆☆			

SYSTEMS

- MS-DOS IBM-PC/Tandy & Compatibles

FEATURES

- The first-ever multimedia entertainment product.*
- More than 24 megs of sound and graphics excitement compressed to just over 7 meg*
- Fully animated talking characters.*
- Intriguing story line.*
- In-depth character development.*
- On-demand hint screens.*
- Rich musical score—digitized sound effects.*
- Supports all major soundboards.*
- The most vivid, lifelike graphics ever seen.*
- A humorous, thrilling adventure with a knockout ending!*

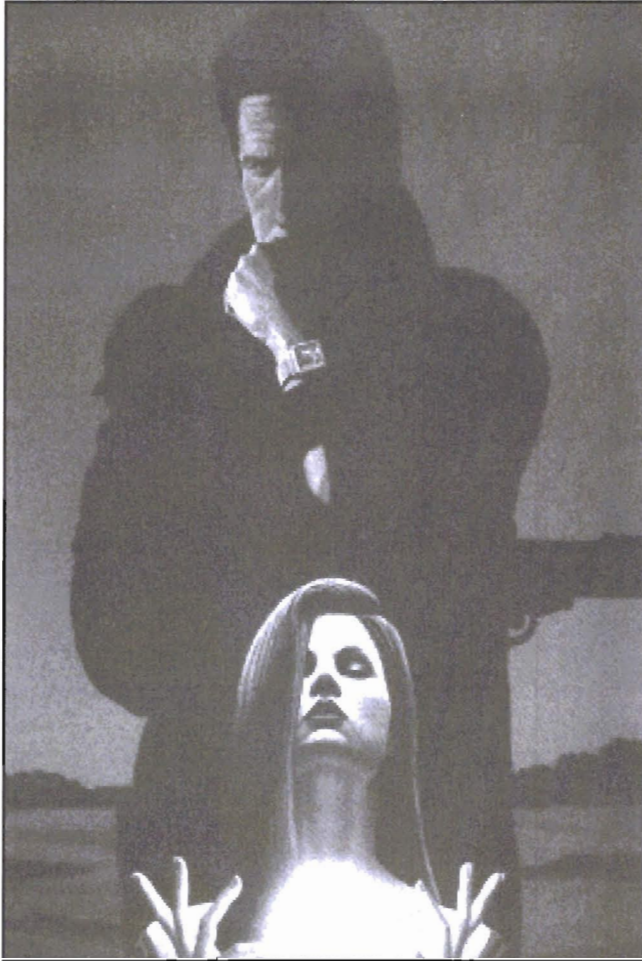

SCENARIO

Martian Memorandum by Access Software is an exhilarating sequel that should be tackled head-on by every hardboiled adventurer! You assume the role of a gumshoe P.I. named Tex Murphy. Hired by Marshall Alexander to seek his kidnapped daughter, you'll scour the streets of San Francisco, then teleport to Martian colonies. During your perilous quest, you must interact with dozens of shady characters, some of whom may aid in solving your case. *Martian Memorandum* takes advantage of full-motion video images. And, to

intensify naturalism, digitized voices spring from the mouths of the actors in a barrage of expressional tones. Among the conventional icons, MM includes a *Travel* icon. At first, there are only a few locations that you can travel to using this icon. After you pontificate with others, however (gaining location clues), the travel list will grow dramatically. The more clues you obtain, the larger the travel list becomes. If the hints in this book suggest traveling to a specific location that's not on your travel list, you must speak to the character who'll give you the clue to that location. Therefore, follow my instructions precisely; otherwise, many locations may not be present on your travel list.

WALK-THROUGH

TEX'S OFFICE

The game begins in Tex's office. Get the mail (you'll find some cash in one of the envelopes). Look at the facsimile. Get the gun hanging on the east wall. On one of the chairs, you'll find the comlink unit. Retrieve the camera located next to the fax machine. Get the lens from the desk and the ammo from the shelf. You'll also find a lock-pick kit on these shelves. Now travel to Terraform.

TERRAFORM

Talk to Rhonda Foxworth, Mr. Alexander's executive assistant, using dialogue response No. 1. Enter the office and talk to Marshall. After he gives you your assignment, walk back into the lobby and enter the ladies restroom by clicking on the switch to the right of the door. From within the bathroom, move the towel and you'll find an earring. Offer Rhonda the earring and use response No. 1. Travel to Alexis's home.

ALEXIS'S HOME

Get the note from the floor. Have you noticed that the right side of the bedspread seems a bit lumpy? If you look beneath it you'll find a card file box. Open the box. Look inside the box. Being a good P.I., did you remember to replace the bedspread? Move the switch on the control panel next to the bed. You may look in the closet and in the desk (by moving the corresponding buttons), but you won't find a thing. Now travel to Jocques Sparrow's place.

JOCQUES SPARROW AND ROCKWELL BACHE

Be very careful what you say to Jocques. In order to get Jocques to answer your questions, use the following responses:

3-1-1-1-1

Ask Jocques about everything. Travel to Rockwell Bache and ask him about all. Save the game. Travel to the Plaza Hotel.

Hint: *Every time you have the opportunity to ask someone questions, always ask about everything on the list. This is very important and is required to advance in the game.*

PLAZA HOTEL, CHANTAL, MAC, AND GUY

From within the lobby of the Plaza Hotel, enter the gift shop by walking east.

Hint: *Don't walk west until you first enter the gift shop.*

Grab the rose. Click the cash on the clerk. Walk two screens west. My, my, doesn't Rhonda look beautiful! Offer her the rose, then use the following responses:

☐ 1-1-2-3-1-2-1

Ask Rhonda about all. Travel back to see Jocques Sparrow. Offer him some cash and he'll give you a roll of film. After traveling to Tex's office, use the camera on the tripod. Use the film in the camera. Before you can take a picture, you must raise the window blinds by moving the switch located next to the filing cabinet. Look through the camera lens. Move the camera to the second-story window (toward the east side of the building). When you see a woman dancing, get ready to snap a picture. When a man appears, snap a few pictures. Exit the camera scene. Take the photographs from the floor. Travel to Chantal Vargas. Use the following responses when conversing with Chantal:

☐ 2-2

Offer Chantal the photos and ask her about all. Now travel to Mac Malden's place and use the following dialogue responses:

☐ 2-2-1-1-2

Travel back to see Jocques Sparrow and ask him about Rick Logan and Galactic Pictures. Travel to Tex's office and use the comlink to contact Stacy. Ask Stacy about everything, especially Andretti, Galactic Pictures, and Nora Desmond Alexander. Travel to Galactic Pictures. Then travel to Guy "Dogface" Callabero's place. Ask him about everything on the list, especially Angelo Andretti. He'll give you an Andretti film—just what Mac Malden needs to close his case. Travel to Mac Malden's place. Offer him the Andretti film, then ask him about all. Travel to Johnny Fedora's domain.

JOHNNY FEDORA

Walk east while avoiding the dog and the red bubbling puddle of radioactive seltzer. Continue walking east until you reach the shed. Open the door. Get the aluminum ladder. Open the small compartment located between the rusted truck and the shed. Get the acid-proof boots. Use the boots. Now you can safely walk across the puddle of seltzer. Walk to the boxcar. Use the ladder to climb on the roof of the boxcar. Climb through the hole. Once inside the boxcar, get the butter knife from the dresser, then look at the newspapers. Open the dresser drawers and take the cat food. Move the east dresser and open the tear in the lead shielding. Try opening the safe in the wall. After being zapped by 220 volts, open the front door and exit the boxcar. Climb the ladder and use the cat food on the cat. Climb down the ladder and walk to the shack. Open the door. Move the lever to turn off the generator. Enter the boxcar. Open the safe and examine the contents. Anytime now you should receive a message from Stacy. And the news isn't good: Marshall has been brutally murdered. Travel to the murder scene.

MURDER SCENE

After arriving at the murder scene, talk to Mac Malden. Talk to the photographer. Get the keys lying next to the murder victim. Look at the graffiti written in blood. Look at the bucket below the graffiti. Move the bucket and you'll find a bloody dagger. Get the dagger and use it on Mac. Walk over to the body and move the



MARTIAN MEMORANDUM

blanket. Look at the body and at the blood. Now travel to Terraform.

THE SAFE AND RICK LOGAN

After arriving at Terraform, enter Alexander's office and move the left painting. Open the safe using the keys you found at the murder scene. Look at the receipts. Open the desk, then travel to Rick Logan's place. Save the game before attempting the following very difficult arcade sequence.

Hint: Save the game periodically throughout this sequence.

Walk east and prepare to dodge a falling log. Although this log is the size of half a tree, and probably weighs more than a ton, simply slip it into your back pocket. Continue walking east and you'll reach a pool of quicksand. To cross the quicksand, you'll need to step on the correct rocks. Numbering the rocks from left to right, top to bottom, use the following sequence:

□ 2-5-6-9-10-13-16-15-14-17

Save the game every time you reach a rock that doesn't sink. Continue walking east until you reach a pit. Be very careful not to venture too far, since this pit is elaborately camouflaged. Use the heavy log to cross the pit. Enter the shed and get the shovel located at the east side of the room. Move the white privacy screen. Get the key from Rick Logan's neck. Look at the purple chest. Use the key to open it. Look at the contents in the chest. Walk to the west end of the shed. Move the couch. Search the stove. Finally, using your weapon, kill the viper set as a trap in the wooden wall cabinet. Look at the message in the cabinet, then exit the hut. Look at the mound next to the pit. Use the shovel on the mound. Look at the box, then open it. There you'll find an advertisement for Martian Aerobics Academy. Go back to the path entrance. Travel to the smugglers' base.

SMUGGLERS' BASE

Look at everything. Grab some rocks. Throw a rock at the jug to distract the guard. Walk through the wall opening and enter the pyramid. Hide behind the crate located along the west wall. After the guard makes his rounds, quickly take

the food and water from the table. Also, grab the remote control. Use the remote control to open the crate. Walk over to the crate and climb inside. After reaching the red planet, travel to the power plant.

THE POWER PLANT

Walk to the west end of the room and move the red button. Enter the office and retrieve the card key from the white lab coat hanging along the east wall. Talk to Ferris Collett and ask him about everything. Leave Ferris's office and walk to the SXC Security Maintenance System machine. Use the card key in the machine's slot. Enter the restricted area. Save the game. Walk around the trap door and get the monkey wrench. Walk to the east side of the trap door and use the monkey wrench on the magnet. Click on the magnet the instant the trap door opens. Do this several times. Eventually, the magnet will lift you to the upper platform. Walk through the east doorway and you'll notice a crate. Look at it and you'll find some Allen wrenches and an awesome hover board. Open the door. Go to the door. Leave the restricted area. Travel to Dr. Lawrence Barkley's place.

DR. LAWRENCE BARKLEY

Look at the statue. Look at the shelves and locate the brown Kevlar "Identifier" box (facial kit). Get the box and Dr. Barkley will enter the office. Talk to Barkley, then click on the travel icon. A message from Mac Malden will appear on the comlink concerning the DNA tests. After the message, travel to Lowell Percival's place. He'll tell you that he wants something from Castro's safe. Travel to the Aerobics Academy.

AEROBICS ACADEMY AND JANE MANSFIELD

After reaching the Aerobics Academy, locate Jane. Talk to her and ask her about everything. Walk beyond the counter and look at the purse. Open the purse and you'll find Jane's home address. Travel to Jane's house. When you're in Jane's living room, move the control box located on the table. This will turn on the big-screen TV. Look at the screen. Look at the clothes and the shoes. Open the closet (located along the far wall). Look at the bag. Move the pillows and look at the note. Get the note and travel back to the Aerobics Academy. Talk to Jane and ask her about everything. Travel to Bradley Ericson's place. Ask about all (obtaining glasses). Now travel to the Casino.

MARTIAN MEMORANDUM

THE CASINO

Try opening the Casino doors. Unfortunately, you'll need a password to get inside. Enter the alleyway next to the Casino and move the red rag. Get the broken flashlight, then move the board that's leaning against the east wall. Look at the graffiti—note the password:

❑ Bombshell

Leave the alleyway. After opening the Casino doors, walk over to the right staircase and you'll find a card. Get the card. Open the restroom door (located next to the right staircase). Go to the restroom. Notice which stall the man has just exited. Open the stall door and get the blueprints. Go back into the lobby and walk east. Open the office door and use the following responses when conversing with Big Dick:

❑ 1-1-2

Now you must move very quickly. Get the computer access card from the desk. Look at the light above the portrait. Move the light. Go to the secret passageway. Save the game. Look at the alarm control unit, then use the hover board to float between the laser beams (you may find that using the arrow keys, rather than the mouse, will make it easier to dodge the laser beams). After dodging the deadly beams, use the safe card key in the slot of the machine. Quickly use the facial kit on the scanner. Look at everything in the safe. Get the Martian Memorandum, the cash, and the markers. Go back to Big Dick's office and open the vent. Go to the vent. Crawl through the ductwork following the directions on the blueprint (you must get from one shaded area to the other). After weaving your way through the ventilation system, leave the Casino and travel to Lowell Percival. Ask him about all. Travel back to the Casino. Wait for Rocky to enter the alleyway. Follow him, then quickly hide behind the rubble located along the west wall. Immediately after Rocky opens the secret passageway, enter it before the door closes. Talk to Larry and he'll give you an amulet. Now you can leave the alley and travel to Michelle Bloodworth's place. Ask her (him) about all, then travel to the remote outpost.

REMOTE OUTPOST AND THE FINALE

Begin by helping the injured man. Move the I-Beam. Talk to the injured man. Save the game (when someone tells you about a booby-trap, you'd better save the game). Open the door made of heavy steel bars. Get the rebreather. Walk over to the box. Open the box. Get the martian interlock access card, then quickly get the jet-pack. To ignite it, use it on the fire. Travel to the temple. Save the game. Enter the temple and look at everything. Move the right mirror (only once), then move the left mirror. When you move the extinguisher, the guard will fire his laser pistol at you. Fortunately, the beam will be reflected off the mirrors. Walk to the Priestess. Talk to her. Ask Deacon about everything. Leave the temple and travel to the colonists' camp. Next to the child's sand pail you'll find a glass tube filled with HCl₂ acid. Get the acid, then walk west. Move the tail fin of the heat-seeking missile and take the tuning fork. Travel to Bradley Ericson's place and ask him about Cooper Bradbury. You may ask him anything else that you wish. Travel to the cave. Walk east until you reach a door. Use the interlock key to open the door. Look at Marshall's daughter. Talk to her. Move the vent and try escaping through the tunnel. If that doesn't work, move the clothes located in the closet along the east wall. Get the closet rod and use it on the cement near the door. To remove the metal plate, use the HCl₂ acid on it. To open the door, move the button. Now quickly remove the bolt from the top of the chamber. Then talk to Alexis using the following responses:

☐ 1-2-1

Carefully take her bra, then use the bolt on the control panel located near the floor. Again talk to Alexis using the following responses:

☐ 1-1

Walk over to the stone and use the tuning fork on the containment chamber. Get the stone, then go to the tube car.

LOCATION OF OBJECTS

- Acid-proof Boots Compartment (Johnny Fedora)
- Advertisement Box (Rick Logan's Place)
- Allen Wrenches Power Plant
- Aluminum Ladder Shed (Johnny Fedora's Place)
- Ammunition Tex's Office
- Andretti Film Guy Callabero
- Bloody Dagger Murder Scene
- Blueprints Bathroom (Casino)
- Bolt Holding Chamber
- Bra Alexis
- Broken Flashlight Alley (Casino)
- Butter Knife Boxcar
- Camera Tex's Office
- Card Casino
- Card Key Power Plant
- Cash Tex's Office
- Cat Food Boxcar
- Closet Rod Bedroom
- Comlink Tex's Office
- Computer Access Card Big Dick's Office
- Earring Bathroom (Terraform)
- Facial Kit Dr. Lawrence Barkley's Office
- Film Jocques Sparrow
- Food Smugglers' Base
- Glasses Bradley Ericson
- Gun Tex's Office
- HCl2 Colonists' Camp
- Hover Board Power Plant
- Jet-pack Remote Outpost
- Key Rick Logan
- Keys Murder Scene
- Lens Tex's Office

MARTIAN MEMORANDUM

- Lock-pick Kit Tex's Office
- Log Rick Logan's Place
- Markers Safe (Big Dick's)
- Martian Access Card Remote Outpost
- Martian Memorandum Safe (Big Dick's)
- Message Wall Cabinet (Rick Logan's Place)
- Monkey Wrench Power Plant
- Note 1 Alexis's Home
- Note 2 Under Pillow (Mansfield Home)
- Photographs Tex's Office
- Rebreather Remote Outpost
- Receipts Safe (Terraform)
- Remote Control Smugglers' Base
- Rose Gift Shop (Plaza Hotel)
- Shovel Shed (Rick Logan's Place)
- Tuning Fork Colonists' Camp
- Water Smugglers' Base

CHAPTER 16

THE DAGGER OF AMON RA

GRAPHICS:	☆☆☆	STORY LINE:	☆
ARCADE:	N/A	INTERFACE:	☆☆☆☆
DIALOGUE:	☆☆	AUDIO:	☆☆
ANIMATION:	☆☆	LENGTH:	☆☆☆☆
OVERALL ANALYSIS: ☆☆☆			

SYSTEMS

- MS-DOS IBM-PC/Tandy & Compatibles

FEATURES

- Hand-painted, digitized backgrounds inspired by the art of the era.*
- Realistic video-captured and artistically enhanced animation.*
- Deep puzzles with multiple solutions.*
- An intricate and multilayered storyline; several different endings possible.*
- An original stereo soundtrack evocative of the 1920s.*
- An intuitive, no-typing, point-and-click interface.*



SCENARIO

Laura Bow in: The Dagger of Amon Ra is a thrilling murder mystery created by Roberta Williams of Sierra On-Line. (Williams is best known for *The Colonel's Bequest* and the infamous *King's Quest* series.) *The Dagger of Amon Ra* takes place in the large, dangerous city of New York. The year is 1926. You play the role of Laura Bow, a rookie reporter for the New York Register News Tribune. Your first assignment begins easy enough, but then explodes into uncertainty when you get locked inside an imposing museum after a brutal murder. Be prepared to find hidden passageways and concealed rooms while trying to unearth clues that reveal long-lost secrets—and you must do all this before the cold-blooded murderer gets his or her claws on you.

WALK-THROUGH

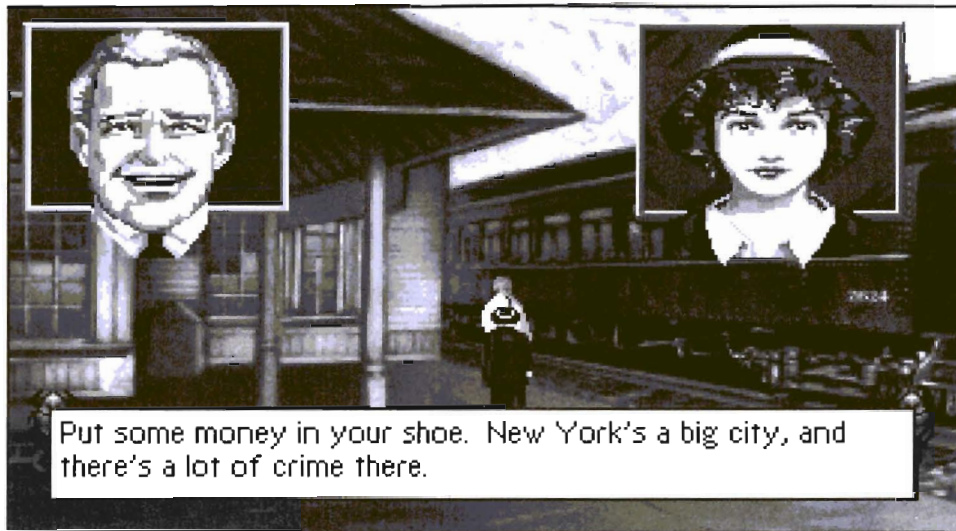

ACT 1: LAURA BOW; A NOSE FOR NEWS

After watching the entire introduction sequence and passing the off-disk copy protection, you'll find yourself in the Tribune building. Welcome to your new job as a reporter for the New York Register News Tribune (Tribune for short). Begin the day by finding the key to your desk. Sit in the chair and look under the lower right-hand corner of the blotter: There you'll find the desk key. Unlock the drawer and get the press pass. Ask Crodfoller about everything in your notebook, especially about the burglary. To do this, click the ask cursor on Crodfoller, then click on the section of the notebook that you wish to ask about. After asking him about the burglary, he'll tell you to talk to Ziggy at the speakeasy—your first lead. But before leaving the Tribune building, there are two things you should do:

- Get the baseball from the trash can
- Read the bulletin board

Leave the building by walking south. Walk to the Police Department (located across the street). Be sure to look both ways before crossing the busy street.

Hint: You must look both ways prior to crossing any street. If you disregard this step, kiss your freckles goodbye.



Before entering the Police Department, look at the bum. Click the hand cursor on him (notice the newspaper). Enter the building and talk to the Desk Sergeant, Dennis O'Flaherty. Try talking to the Detective by clicking the hand cursor on the door at the far end

of the room. Leave the Police Department. Look at the newspaper. There you'll find a valuable coupon for a free sandwich from Luigi's. Take the coupon. Cross the street and locate the man selling corned beef sandwiches. Give Luigi the coupon and place the free sandwich in inventory. Cross the street and enter the Police Department. Give the corned beef sandwich to Sergeant O'Flaherty and he'll be happy to answer any of your questions. Ask him about everything in your notebook, especially the speakeasy. He'll tell you that the password is

Charleston

Leave the Police Department and hail a taxi by clicking the hand cursor on the taxi sign. Show the driver your press pass and he'll ask you for a destination. Using the notebook, highlight (click on)

12th Street Docks

Talk to Steve. Ask him about *Dr. Pippin Carter* and *Dr. Archibald Carrington*. Hail a taxi and travel to the speakeasy. Knock on the side door, then use the following response:

THE DAGGER OF AMON RA

WAIT! I know the secret word!

Under the *Misc.* section of the notebook, you'll find the password *Charleston*. Click on the password and you'll be allowed to enter the speakeasy. Locate Ziggy—he's sitting alone at the first table on the east side of the room. When he asks who sent you, use the following response:



Crodfoler T. Rhubarb

Get as much information from Ziggy as possible. Ask him about every item listed in your notebook. Leave the speakeasy and cross the street. Talk to the kids burning ants with a magnifying glass. Continue talking to them until they tell you of their hobbies. Trade the baseball for the magnifying glass. Hail a taxi. Unfortunately, the taxi that arrives is in dire need of interior cleaning. When the cabby expects a response, use the following reply:

No, sir. I LOVE sitting in filth. Will you take me for a ride?

When he asks for a destination, click on

Leyendecker Museum

Before arriving at the museum, sift through the rubbish and you'll find a laundry claim ticket. This ticket is necessary to complete Act 1. After arriving at the museum, check the front entrance door (it'll be locked). Click the hand cursor on the taxi and travel to Lo Fat's Laundry. Give Lo the claim ticket and he'll give you an evening gown. Walk across the street and enter the speakeasy. Locate the Women's Lounge and talk to the flapper. Ask her about Countess W-C. Change into the evening gown by clicking it on Laura. Leave the speakeasy. This concludes Act 1.

ACT 2: SUSPECTS ON PARADE

Act 2 begins at the museum's entrance. To get inside, you'll need to give the guard your press pass. Get a glass from the buffet table. Walk near the people standing before the bust of Pharaoh Rameses II and listen to their conversation. Repeat this procedure with other groups. After eavesdropping on a few conversations, find Countess Lavinia and ask her about the burglary and Dr. Archibald Carrington. Eavesdrop some more, then enter the Gift Shoppe located toward the east side of the room. Look at the display case behind the cash register: There you'll find many daggers. Using the magnifying glass, look at each dagger. Eventually you'll find the original Dagger of Amon Ra (the one that doesn't have any writing on the blade). If you're having difficulties locating it, try looking at the daggers at the far north end of the display case. When the guard appears, you'll know that you've found the correct dagger. Eavesdrop some more. Look closely at the two urns at either end of the rotunda. Use the magnifying glass on the urns. Enter the archway along the north wall. Again, the guard will stop you. He'll ask you to join the rest of the guests in the rotunda. Continue to eavesdrop until Steve Dorian appears and strikes up a conversation with you. Eavesdrop until you've heard all 14 conversations. Then walk through the archway along the north wall. Enter the room containing dinosaur displays. Walk west and the guard will ask you to leave. From the



Skeleton Room, walk east into the Pterodactyl portion of the Dinosaur Exhibition. Walk through the north doorway and you'll see a Tyrannosaurus Rex. Push the button on the panel in front of the display to hear Rex talk. Find the bone display. Take the bone. Exit this room. Walk through the west doorway. From within the Suit of

THE DAGGER OF AMON RA

Armor Room, walk due north until you see a wooden door to your left. Try opening the door. If it's locked, continue walking north. From the Ancient Egypt Exhibit (the room with the mummified corpse), walk west. Look closely at the Rosetta Stone (along the west wall) using the magnifying glass. On the floor in front of the mummy coffins you'll find a gold ankh medallion. Use the magnifying glass



to look at the ankh, then place it in inventory. Look at the red liquid using the magnifying glass, then open the third mummy coffin. Oh no—Dr. Pippin Carter has been murdered! Examine his body with the eye cursor and the magnifying glass. Make sure you find the note pad located in his breast pocket. This concludes Act 2.

ACT 3: ON THE CUTTING EDGE

Begin by taking a deep breath—Act 3 is a tough act to complete.

When you're ready, walk through the archway along the north wall. From the room with the dinosaur skeletons, walk east, then west into the room containing the suits of armor. Walk two screens north and you'll be in the Ancient Egypt Exhibit Room. If you haven't already done so, look closely at the Rosetta Stone located along the west wall. Use the

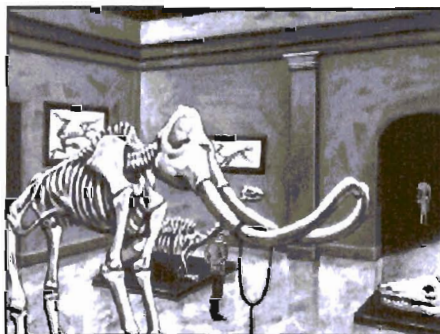

magnifying glass to view the hieroglyphics. Check your notebook—just to be sure you've viewed the hieroglyphics correctly.

Hint: *Whenever you encounter others roaming throughout the museum, be sure to ask them as many questions as you can.*



Leave the Ancient Egypt Exhibition room and retrace your steps to the room with the skeletons. Walk west into the Old Masters Gallery. Walk south into the room with the *Thinker* statue and you'll hear voices coming

from Yvette's office. Use the drinking glass on the door to overhear their conversation. Do this every time you hear voices coming from the blind side of closed doors. After eavesdropping on their entire conversation, walk south and you'll enter Dr. Olympia Myklos's office. Look at the snake oil. Search the area around the two cages (along the east wall). Eventually you'll find a cloth covering an object. Remove the cloth and you'll find the other half of the Rosetta Stone. Read the hieroglyphics using the magnifying glass. Leave Olympia's office and enter Yvette's office. Look in the trash can. Remove the sheet of carbon paper. Hold the carbon paper up to desk lamp to read it. Look at the desk lamp, then turn it off. Walk through the east doorway and you'll enter President Carrington's office. Listen to any voices coming from Yvette's office. Look at the fireplace. Get a lump of charcoal. Look at the items on the desk, especially the phone list. Look at the name:

B. Sayff KL-0527

The last four digits are the combination to the wall safe (located behind the picture above the fireplace). Open the safe by clicking on the following numbers:

0527

Read the former President's personal diary using the magnifying glass. Leave Carrington's office. Unscrew the bulb from the desk lamp.

Hint: *If the bulb is too hot to unscrew, leave Yvette's office momentarily. On your return, the bulb will have cooled.*

Leave Yvette's office and click the hand cursor on the head of the *Thinker*—this will open a secret door leading to a staircase. Walk through the east archway and you'll see the stairway. Replace the burned-out bulb to avoid falling to your death. Once downstairs, find the alcove located along the west wall. Break the glass using the display bone. If the guard appears, repeat this procedure until you get the lantern. Enter Heimlich's office by walking through the north doorway. Locate the mousetrap and trip it with the bone. Get the cheese. Leave Heimlich's office and enter the Alcoholic Preservation Lab by walking through the east doorway. Eavesdrop if you can, then find the following vat:

❑ VAT 13

Click the hand cursor on the ladder and you'll find the stolen Dagger of Amon Ra. Now walk through the doorway at the far end of the room. Leave the lab and go back upstairs. From the room with the *Thinker*, walk through the west archway into the Old Masters Gallery, and find the painting entitled

❑ *A Heartwarming Story*

The painting is located on the east wall above the bench. Look closely at the painting and you'll see a portion of it sparkle. Use the magnifying glass on the sparkle several times and you'll find a key. To get the key, pry it loose with the Dagger of Amon Ra. This key opens a trunk located in the Mammalogy Lab. You can't open the trunk until later in the game, however. Once you have the skeleton key, go back downstairs via the secret stairway. Enter the lab. Enter Ernie's office. If he's there, or the door's locked, go back upstairs and enter the Pterodactyl Exhibition room. Examine the dead body and you'll realize that it was brutally decapitated. To find the head, walk west (into the room with the suits of armor), then south. Look at the gray head on the wall and you'll know the victim was none other than Ziggy himself. Go back to Yvette's office and look

at the bloody paper cutter. From Yvette's office, enter President Carrington's office and you'll find another dead body. Examine the body that *appears* to be Carrington himself. Look at the clock, then at the letters on the desk written in blood. The initials are

❑ C.P.

The initials stand for *Crime and Punishment*. Look for the book with this title and you'll find a police file on Watney Little. After closer examination of all the evidence, leave Carrington's office and travel to the lower level using the secret staircase. Enter Heimlich's office and look at the books. Look for a book written by Wolf Heimlich himself. Leave Heimlich's office and enter the lab. Enter Ernie's office by walking through the east doorway. Get the wire cutters from the toolbox and the snake lasso from beneath the desk. Push the large button on the wall behind Ernie's desk to open a secret passageway in the Mammalogy Lab. Leave Ernie's office and go back upstairs.

Travel to the Pterodactyl Exhibition room and click the eye cursor on Ziggy's body. Using the wire cutters, snip a piece of wire that formerly suspended the Pterodactyl. Walk into the Ancient Egypt Exhibition room and you'll encounter Dr. Smith. Ask him about the ankh, Egyptology, and Rameses Najeer. Travel downstairs and enter Heimlich's office. Search this room until you hear an intercom message from Olympia. Now turn on the lantern and walk to the northeast corner of the office. Click the hand cursor on the lowest display of medals and a secret passageway will appear (always ignite the lantern *before* entering any secret passageway).

Push the buttons on the intercom until you've overheard two conversations. Depending on the game time, you may have some extra time to venture throughout the museum. If the game time has progressed to a certain point, you can travel downstairs and enter the Mammalogy Lab at the far north end of the Alcoholic Preservation Lab. If the door isn't locked, save the game. Once inside the Mammalogy Lab, locate the bottle labeled

❑ *Dr. Moribund's Guaranteed Snake Oil*

Place the snake oil in inventory. Walk to the cold storage locker and open the

THE DAGGER OF AMON RA

topmost compartment. Get a slab of meat and place it in inventory. Using the skeleton key (which you found in the painting in the Old Masters Gallery) open the trunk and throw the slab of meat inside. Use the magnifying glass to examine the skeleton. Get the gold pocket watch. Open it and read the inscription, then place it in inventory. Close the trunk (and the cold-storage locker) and leave the lab via the secret passageway. Go back upstairs. Enter Olympia's office by walking one screen south from the *Thinker*. Light the lantern. Click the hand cursor on the right horn of the skull. This is the third secret passageway. Travel back to the room containing the suits of armor and look closely at the armor located near the center of the room. There you'll find another dead body. Go back to Ernie's office. Now feel free to roam throughout the museum until 2 a.m. If the game time has reached 2 a.m., go into the room containing the dinosaur skeletons and you'll find yet another dead body (sheesh, they're dropping like flies around here). Examine the body closely and you'll find some incriminating hairs. Place these hairs in inventory, then examine the corpse's mouth with the magnifying glass. Walk west and Act 3 will end.

ACT 4: MUSEUM OF THE DEAD

Act 4 begins in the room with the *Thinker*. Enter Yvette's office. Communicate with her. Exit the office and you'll encounter Steve and Olympia. Steve will automatically enter Yvette's office. Listen to Steve and Yvette's conversation by placing the glass against the office door. Now go downstairs and enter the lab.

Remain in the lab until the game clock strikes 3 a.m., then enter Yvette's office. There you'll notice that a struggle has taken place. Get the lady's shoe and examine the red hairs and the shed of clothing fabric. Leave Yvette's office and enter the Old Masters Gallery by walking through the west archway. Do you notice anything awkward? Examine the (new) statue. Shatter it using the bone. Examine the body and take the bifocals containing a fingerprint. Also take the red hairs. Enter the room with the dinosaur skeletons by walking north. Walk east into the Pterodactyl Exhibit. Then walk west into the room containing the suits of armor. Next to the dog you'll see a boot. It sure looks like Steve's boot, doesn't it? Get the boot and travel back to the *Thinker*. After a short animated sequence, save the game, then enter Olympia's office. When you see the cobra, you must act quickly and correctly. If you move too slowly or make a wrong move, the

cobra will strike and the game will end. To repel the snake, use the snake oil three times. While the viper is cornered, grab it using the snake lasso that you found in Ernie's office. To place the snake into the cage, click the lasso on it.

Hint: DO NOT look at the dead body! You must refill the bottle of snake oil before examining the corpse.

Now you must refill the bottle of snake oil. The snake oil is located in the Alcoholic Preservation Lab. After entering the lab, look at the container on the left-hand table (the oily substance). Click the empty bottle of snake oil on this container to refill it. You may need to click the bottle on the container a few times before it's completely refilled. Once the bottle is full, travel to Olympia's office and examine the dead body. Look closely at the ankles and you'll see a snake bite. Find the smelling salts located under her coat. After examining the body, leave Olympia's office and Act 5 will begin.

ACT 5: REX TAKES A BITE OUT OF CRIME

Act 5 begins in the room with the dinosaur skeletons. And guess what? The person chasing you is the murderer! Run east and quickly shut the door behind you. Wrap the wire around the doorknobs—this will slow down the murderer. Run west and close the door. Bar it with the board, then run north. When you see a wooden door and a chair, use the chair to open the transom above the door. This will trick the murderer into thinking that you've climbed into the storage room. Run north into the Ancient Egypt Exhibition room, then run west. Quickly hide in the left mummy coffin to elude the murderer.

Leave the Ancient Egypt Exhibition room and enter the storage room. To block the entrance door, move the (hanging) crate in front of the doorway and cut the cable with the wire cutters. Move the crate, located at the northeast corner of the room, and you'll find a utility elevator. Enter the elevator and click on the lever. Exit the elevator and you'll be in the mummy storage room. Find the small mummy named Pu and prop him up against the door. Find the lid of the mummy case containing Pharaoh Mackenzietep. If you look at the top of the lid, you'll

THE DAGGER OF AMON RA

see a snake. To open the lid, use the lasso on the snake, then click the hand cursor on the lid. Welcome to the Sun Worshiper's Room. To pass the test, you must answer their questions using hieroglyphics. You have these hieroglyphics in your notebook because you examined both halves of the Rosetta Stone with the magnifying glass. The answers follow:

- WOMB
- TOMB

Spell these words using the notebook. When you arrive in the furnace room, you'll need to perform three things rather quickly. Therefore, this would be an opportune time to save the game. Perform the following procedure precisely:

- Remove the coal from Steve's face by clicking the hand cursor on it.
- Revive Steve with the smelling salts.
- Give Steve his boot before he stands.

To exit the furnace room, click the hand cursor on the large, ornately carved stone. Before entering the tunnel, ignite the lantern. Inside the tunnel you'll encounter a nest of king cobras and a pack of rats. To repel the cobras, use the snake oil. To rid the tunnel of the rats, throw the cheese through the first opening. Exit the tunnel via the second opening. If you exit through the first opening, you'll become toast, since this is the flue leading from the furnace. After passing through Rex's mouth, push the button to make him talk.

ACT 6: THE CORONER'S INQUEST

To successfully complete the game, you'll need to answer the Coroner's questions correctly and have the following items in inventory:

- Dagger of Amon Ra
- Yvette's shoe
- Wire cutters
- Ankh medallion
- Wart hog hair

- Pippin's note pad
- Bifocals
- Watney's police file
- Pocket watch
- Red hair
- Carbon paper
- Grapes

Below are the Coroner's questions and the correct answers:

- Who murdered Dr. Pippin Carter?*
Detective Hanrahan O'Riley
Cover another crime
- Who murdered Lawrence 'Ziggy' Ziegfeld?*
Detective Hanrahan O'Riley
Cover another crime
- Who murdered Ernie Leach?*
Detective Hanrahan O'Riley
Cover another crime
- Who murdered Yvette Delacroix?*
Detective Hanrahan O'Riley
Revenge
- Who murdered Countess Lavinia Waldorf-Carlton?*
Detective Hanrahan O'Riley
Cover another crime
- Who was the skeleton found in the steamer tank?*
Dr. Carrington III
- Who murdered Dr. Archibald Carrington III?*
Watney Little
- Who impersonated Dr. Archibald Carrington III?*
Watney Little
- Who murdered Watney Little?*
Detective Hanrahan O'Riley
Cover another crime

THE DAGGER OF AMON RA

- ❑ *Who actually stole the Dagger of Amon Ra from the Ancient Egypt exhibit?*
Watney Little
- ❑ *Who manipulated Watney Little into stealing the Dagger of Amon Ra?*
Detective Hanrahan O'Riley
- ❑ *Who was the woman involved in stealing paintings from the Old Masters Gallery?*
Countess Waldorf-Carlton
- ❑ *Who was the man involved in stealing paintings from the Old Masters Gallery?*
Watney Little
- ❑ *Who was the middleman who provided forged paintings for Countess and sold the real ones for her?*
Lawrence 'Ziggy' Ziegfeld
- ❑ *Who is the High Priest of the Amon Ra Sun Worshipers?*
Rameses Najeer
- ❑ *Which museum employee runs a 'fencing' operation as a sideline business?*
Ernie Leach

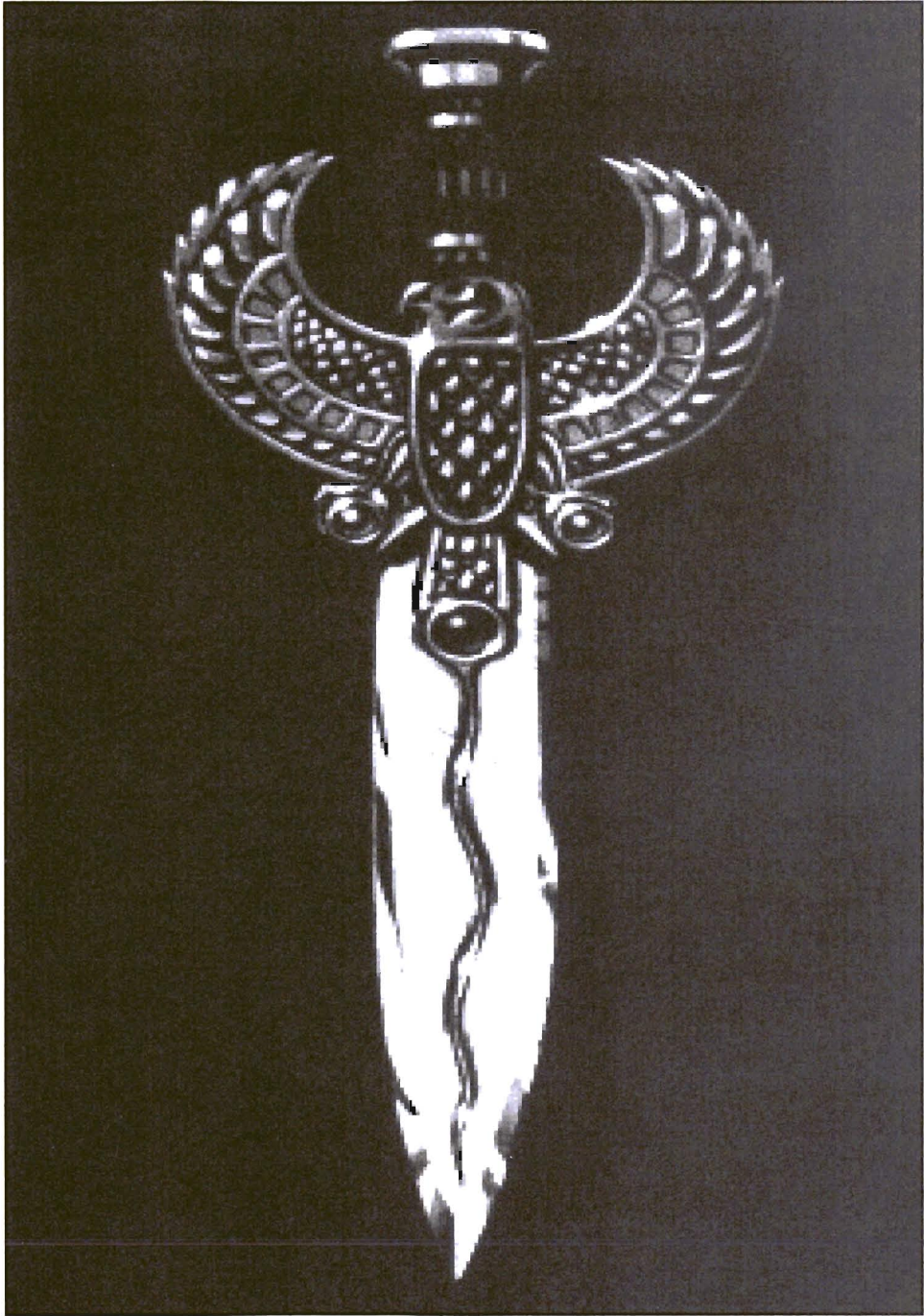

Dagger of Amon Ra

LOCATION OF OBJECTS

- Baseball Trash Bin (Tribune Building)
- Bifocals Dead Body
- Bone Bone Display (Museum)
- Boot Suit of Armor Exhibit
- Bulb Lamp (Yvette's Office)
- Carbon Paper Trash Bin (Yvette's Office)
- Charcoal Fireplace (Carrington's Office)
- Cheese Mousetrap (Heimlich's Office)
- Corned Beef Sandwich Luigi
- Coupon Newspaper
- Dagger of Amon Ra Vat 13
- Desk Key Under Blotter (Tribune Building)
- Evening Gown Lo Fat's Laundry
- Glass Buffet Table (Museum)
- Gold Ankh Medallion Ancient Egypt Exhibit
- Gold Pocket Watch Trunk
- Hair Dead Body
- Lady's Shoe Yvette's Office
- Lantern Alcove
- Laundry Claim Ticket Filthy Taxi
- Magnifying Glass Children
- Meat Cold-storage Locker
- Newspaper Bum
- Note Pad Dr. Pippin Carter
- Police File Book (*Crime and Punishment*)
- Press Pass Desk (Tribune Building)
- Red Hairs Dead Body
- Shed of Clothing Yvette's Office
- Skeleton Key Painting (*A Heartwarming Story*)
- Smelling Salts Dead Body
- Snake Lasso Ernie's Office
- Snake Oil Mammalogy Lab
- Wire Pterodactyl Exhibition Room
- Wire Cutters Ernie's Office

MAPS

LEYENDECKER MAIN LEVEL

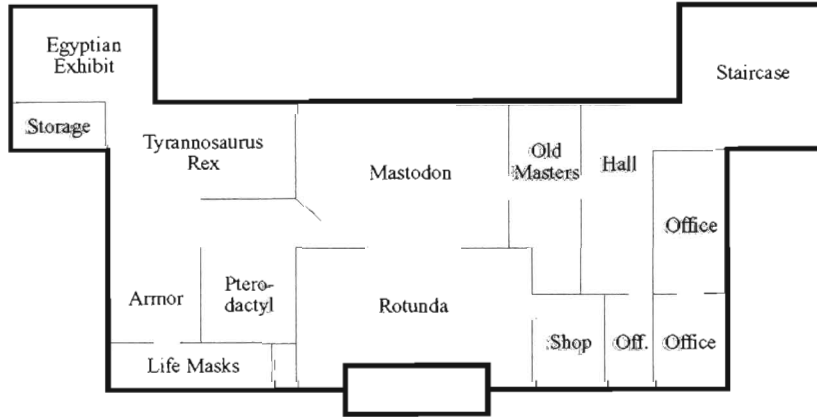

LEYENDECKER BASEMENT

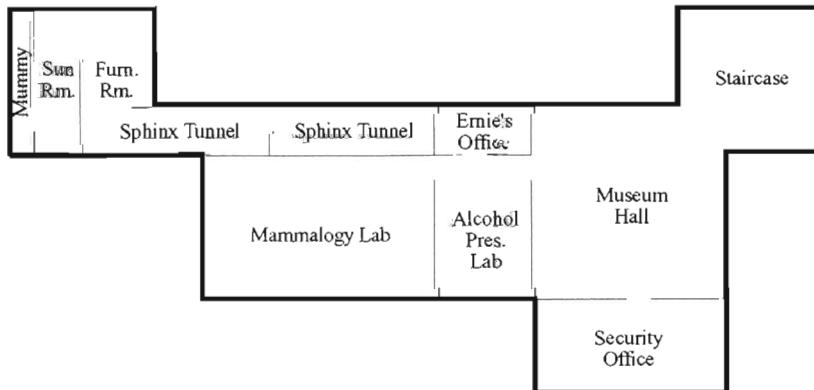

CHAPTER 17

POLICE QUEST 3

GRAPHICS:	☆☆☆☆	STORY LINE:	☆☆☆☆
ARCADE:	☆☆	INTERFACE:	☆☆☆☆
DIALOGUE:	☆☆☆☆	AUDIO:	☆☆☆
ANIMATION:	☆☆☆☆	LENGTH:	☆☆☆☆
OVERALL ANALYSIS: ☆☆☆☆			

SYSTEMS

- MS-DOS IBM-PC/Tandy & Compatibles
- Amiga
- Macintosh

FEATURES

- Video-captured human actors with lifelike action sequences and realistic sound effects.*
- A searing, music-card compatible stereo soundtrack by Jan Hammer of Miami Vice soundtrack fame.*
- Hand-painted, digitized color scenes and graphics.*
- Point-and-click, hands-on, no-typing interface.*
- Real scenarios. Exciting animation puts you in the driver's seat.*
- Real cases. Follow a dangerous and puzzling trail of vicious and brutal cult killings.*
- Real drama. There's been a fatal freeway traffic accident and you've been called to investigate.*
- Real action. Hit the dirt! The criminals are ruthless and will try to gun you down.*

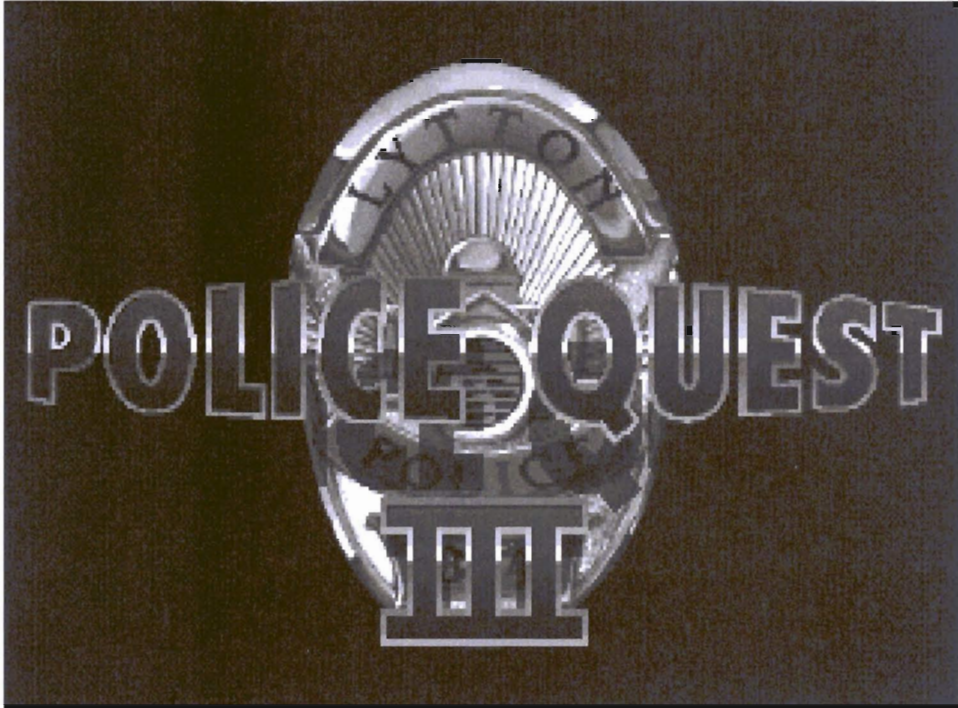

SCENARIO

*Yankee 3. Please respond to an 11-44 at 4th and Elm, 4th and Elm. Code 1.
Yankee 3, 10-4. En route.*

Late one night the scanner crackles with some shocking news: Your wife was viciously stabbed! As you painfully watch your love spurn the passionless fingers of death, your rage builds into a single obsession—bust the scumbags who attempted to murder your beloved wife. *Police Quest 3* was designed by Jim Walls, a retired California Highway Patrol Officer. While Mr. Walls was recuperating from injuries incurred in an actual police shoot-out, Ken Williams, President of Sierra On-Line, asked him to translate his career experiences into a complex, accurate computer adventure. Thus was born the *Police Quest* series, which contains actual events that occurred during Walls's career. Thumbs-up to Mr. Walls and the entire Sierra family for bringing this exciting series to life.

WALK-THROUGH

DAY 1: THE LYTTON POLICE DEPARTMENT

The game begins on the second floor of the police department. Enter Sonny's office and examine the In/Out basket. Get the complaint form filed against Officer Morales. Leave the office and walk south, then east. Enter the Briefing Room. Talk to Officer Morales about the complaint filed against her.

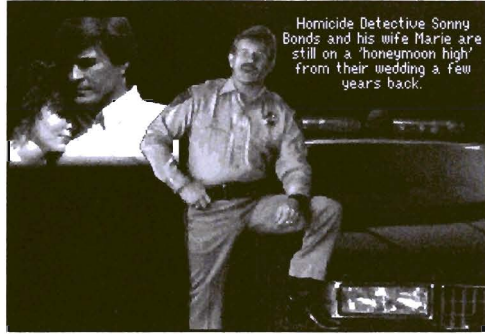

Being the Sergeant, you must conduct the meeting. Do this by getting the clipboard hanging on the left side of the podium. After the meeting, go back to your office and interview Officer Morales. When the decision dialogue box appears, choose

SUSTAINED

Leave the office and enter the elevator by clicking the hand cursor on the elevator button. Select level one. Enter the locker room and locate your locker. The combination can be found on the inside cover of the game documentation (copy-protection). After opening the locker, take the following items:

- Flashlight
- Notebook
- PR/24 Nightstick

Leave the locker room and find the storage closet located next to the fire extinguisher. Open the closet door and take the batteries and some road flares. Go back to your office and get the requisition form from the In/Out basket. This form is required to obtain a computer



access card. Take this form to the computer room located on the third floor. Give the form to Mike Downs, the head technician. Get the access card. Explore the police department. When paged, use the phone on your desk to call dispatch.

ASPEN FALLS

It's time to hit the road in search of lawbreakers. To reach the parking lot, use the elevator and select the ground floor. Enter the police car by clicking the hand cursor on the driver's-side door. Note the time in the upper left-hand corner.

Hint: *When issuing citations, write down the game time.*

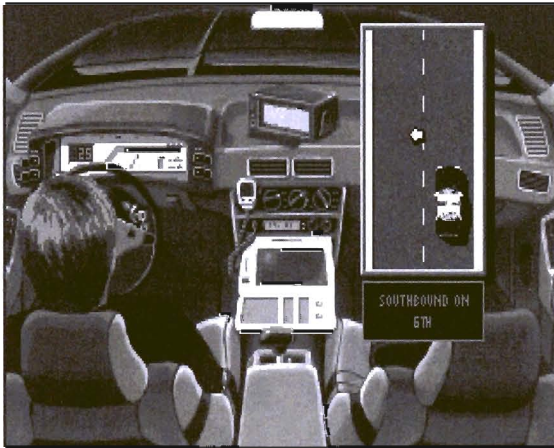

To operate the squad car, move the cursor over the window containing the bird's-eye view of your vehicle. To accelerate, click the cursor in front of the vehicle. To brake, click the cursor behind the vehicle. If you want to turn, click the cursor on the appropriate side of the vehicle. You can judge your speed by the digital speedometer above the steering column.

Hint: *Take turns slowly. Remember, the squad car doesn't handle like a Corvette! If you take a turn too quickly, you'll crash and your career will be short-lived.*

Travel to Aspen Falls Recreational Area (refer to the map at the end of this section). You'll know when you reach your destination by a small window that reads

POLICE QUEST 3

❑ *Aspen Falls*

Stop the vehicle and turn off the ignition. Exit the squad car by clicking the walk cursor on the driver's-side door.

Hint: You can only exit the vehicle at the proper locations.

Talk to the woman holding the child. Walk east and prepare for your first arrest. After encountering the deranged man, click the hand cursor on him and he'll throw your badge into the lake, then jump in himself. After this occurs, search his clothes. Take his driver's license and his keys. Throw his keys into the lake.

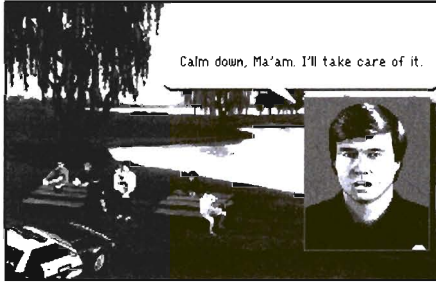

When he wades from the water, click the nightstick on him, then cuff him. Approach the squad car. Frisk the suspect (by clicking the hand cursor on him) and you'll find a knife. Place the suspect into the patrol car. After entering the vehicle, look at his driver's license and write down the DL number:

❑ 789612

Turn on the mobile computer by clicking the hand cursor on the red button. Choose *DRIVER'SID* and enter Forbes's D.L. number. Now travel to the station and throw this creep in the slammer.

Once you're back at the station, place your weapon in an empty gun locker. Walk through the automatic doors leading to Prisoner Booking and the jail. Give Officer Smith the suspect's knife and his driver's license. Click the hand cursor on the door and Officer Smith will ask you to enter a violation code. On page 4 of the game documentation you'll find the codes required to pass the off-disk copy protection. In this case, use the penal code for

❑ *Possession of a concealed weapon*

Before going back on patrol, remember to get your handcuffs from the drawer and your weapon from the locker.

INCIDENT ON HIGHWAY 41

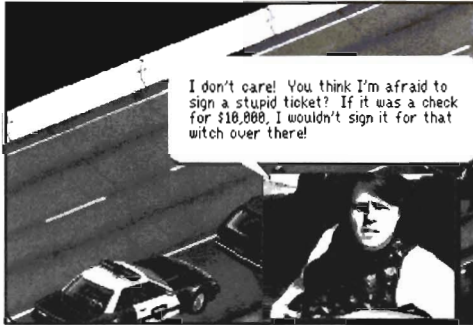

To reach the incident on Highway 41, travel south on 6th Avenue. Turn right on Lilly Street, then right again on 4th Avenue. Merge onto Highway 41 (traveling east) and eventually you'll reach the incident. Exit the vehicle and click the walk cursor on the PASSENGER SIDE door of the station wagon. This will prevent you from being struck by oncoming traffic. Talk to friendly Officer Morales, then talk to the driver of the station wagon. Talk to Morales again. When the decision dialogue box appears, choose the following icon:

- SIGNATURE*

Enter the squad car and continue patrolling Highway 41. During your patrol, you'll encounter three separate offenders:

- A low rider
- A speeder
- A drunk driver

The paragraphs that follow explain how to deal with these offenders.

THE LOW RIDER

If you encounter a slow-moving vehicle in the left-hand lane, you've found the low rider. Remain approximately one car-length behind him as you turn on the lights and siren. Eventually he'll pull over. Note the time! Click the eye cursor on the vehicle, then on the license plate. Write down the license number:

- 22776

POLICE QUEST 3

Walk to the passenger side of the suspect's vehicle. Request his driver's license and vehicle registration. Walk back to the squad car. Enter his D.L. number and registration number into the computer. After the computer clears him, issue a ticket by inserting his D.L. into the slot next to the CRT. Choose *FORM 900*. Enter the time when you first pulled him over and the correct vehicle code for

❑ *Driving too slow in a fast lane*

You'll find this code on p. 4 of the game documentation. Get the ticket from the computer. Give the ticket to the perpetrator and get back on patrol.

THE SPEEDER

If the speeding car is black, DO NOT attempt to pull it over—I repeat, DO NOT pull it over! It's an unmarked police car and you wouldn't want to foil its pursuit. If the car's white, however, hit the flashing lights and siren and step on the gas. Note the game time. After pulling over the speeder, exit your vehicle and look at his license plate number:

❑ 34567

To avoid being struck by oncoming traffic, walk around the passenger side of the speeder's car. Talk to the driver. Go back to your squad car. Enter his license plate number and D.L. number into the mobile computer. Insert the driver's license into the computer and select *FORM 900*. Enter the time in Military format, then the vehicle code for speeding. You'll find the vehicle code on p. 4 of the game documentation. Remove the ticket from the computer and present it to the speeder.

THE WEAVER

Eventually you'll encounter a car weaving all over the road. When you confront such a vehicle, turn on your flashing lights and siren. After the suspect pulls over, look at his plate:

❑ 01923

Approach the suspect's vehicle. Talk to the perpetrator several times. Give him the Field Sobriety Test by moving your finger across the screen (from the extreme right to the extreme left). Frisk the drunk, then cuff him. Click the hand cursor on the passenger door of the squad car, then on the driver's-side door. Run his plate on the computer, then cart him off to jail.

Place your weapon in an unoccupied locker. Enter the police station. Remove the handcuffs and give the perpetrator a breath test using the Gas Chromatograph located on the table near the east side of the room. To operate the Gas Chromatograph, you must first turn it on by clicking the hand cursor on the red button. Click the hand cursor on the hose and watch the numbers rise. Click the hand cursor on the printout to exit this scene. Have the suspect empty his pockets by clicking the hand cursor on the drawer beneath Officer Smith. Click the hand cursor on the north door. Book him using the appropriate vehicle code located on p. 4 of the game documentation. Enter the code for

❑ *Driving under the influence of intoxicants*

THE ASSAULT AT OAK TREE MALL

After busting the drunken driver, you'll see a short animated sequence. Then you'll be paged by dispatch. Get your gun from the locker. Hustle to your office and call dispatch. You'll be requested to respond to an assault at the 300 block of east Rose.

After arriving at Oak Tree Mall, take the gold chain from Marie's hand and travel with her to the hospital. When you're allowed to see her, click the eye cursor on her to get a closer view. Talk to Marie, then leave the hospital. Talk to the reporter and he'll give you his business card. From the inventory window, place the batteries (which you took from the storage locker) into the flashlight. Click the flashlight on Sonny and search the ground near Marie's vehicle. Get the Bronze Star. Look at the Bronze Star. Click the hand cursor on the squad car and an exhausting Day 1 will come to an end.

DAY 2: HOMICIDE

Get Marie's music box from the shelf of the wardrobe chest. To exit the bedroom,

POLICE QUEST 3

walk south. Enter the homicide office (2nd level). The Captain will assign you to Marie's case. He'll also give you a similar stabbing case number. Write these two case numbers down:

- 199144—Marie's case number
- 199137—case number of a similar stabbing

Use the computer (in the homicide office) by slipping your computer access card into the appropriate slot. When you see the computer screen, choose the following icons:

- HOMICIDE*
- SERIAL #*

Enter the serial number engraved on the back of the Bronze Star. That serial number is

- 09987

The screen will display the following information:

- U.S. Army Bronze Star*
Awarded to Samuel Britt, Infantry
for meritorious Service during WWII

Samuel Britt murder victim
See case number #199124



Review the case number. Also review both cases the Captain gave you. Note the location and time of each murder. When you've finished with the computer, talk to Officer Hanks (he's reading a newspaper). Remember the reporter you spoke with at the crime scene? It's time to give him a call. You'll find his phone number on the business card:

- 555-0707

Bring the gold chain and the Bronze Star to the Evidence Lockup and the Lab Analysis room. This room is located next to the jail. Talk to Officer Martha Gibbs. Place the Bronze Star and the gold chain into the drawer. When Officer Gibbs asks you for a case number, give her Marie's case number:

❑ 199144

Travel to the hospital. Buy a rose at the Flower Shop. Talk to the receptionist to find out what room Marie is in:

❑ 307

Enter Marie's room. Click the eye cursor on Marie. Give her the rose and the music box. Try speaking to her. Give her a kiss before leaving. It's time to call it a day.

DAY 3: THE BAG LADY

Check the In/Out basket on your desk in the homicide office. You'll find a note stating that a certain Carla Reed phoned about an article she saw in the newspaper. The address given is of an old warehouse.

Hint: *The warehouse will NOT appear in a window. Therefore, when you think you're in the general vicinity, try exiting the vehicle. If you can't exit the vehicle, drive a bit farther and try again. Eventually you'll find the old warehouse.*

After finding the old warehouse, clamber up the staircase and talk to the bag lady (she's asleep under the newspapers). Click your wallet on her to identify yourself as a police officer. Use the handcuffs on the shopping cart and she'll agree to go with you to the police station. Enter the homicide office. Talk to Carla. Give Carla the lunch bag located on the desk directly behind yours. Talk to Carla again. Turn

POLICE QUEST 3

on the computer and choose the following functions:

- TOOLS*
- DRAWING COMPOSITE*

Click through the features until Carla says they all look okay. Then select

- SEARCH*

The computer will display three suspects that match the drawing composite. Carla will then give you positive identification. When she does, read about the suspect. Turn off the computer and talk to Carla: She'll want to go back home. After taking her to the warehouse, remember to remove the handcuffs from the shopping cart.

DAY 4: THE TRIAL

Okay, you've made it to the fourth day of the game and you're wondering how to get the ball rolling: Check the In/Out basket on your desk and you'll find a subpoena. Before heading to the Courthouse, travel to the third floor and get the tracking device from the loaner cabinet next to Mike's desk. Go to the squad car. Get the speedometer-calibration chart from the glove-box. Travel to the Courthouse. Enter the Courthouse proper. Talk to the Deputy District Attorney. When asked for the calibration chart, click it on the District Attorney. If you've entered the correct time on the ticket, you should win the case. Leave the Courthouse and Officer Morales will ask you to stop at the mall so she can make a phone call. The minute Officer Morales leaves the vehicle, take the key from her purse and exit the vehicle. Locate Zak, the keymaker. Have him make a duplicate key. Return the original key before Morales returns.

THE MURDER

Investigate the murder in the alley of the 300 block of west Rose. Once on the scene, open the trunk of your vehicle and remove the following items:

- Scraper
- Envelopes
- Toothpicks

Examine the dead body. Lift the victim's shirt and click your notebook on the pentagram carved deep into his chest. Look at his fingernails. Use a toothpick to get some hair and skin samples. Click the hand cursor on the victim's pockets to retrieve his driver's license. Click the eye cursor on the rear of the abandoned vehicle. To get a paint transfer sample, use the scraper. Return all unused items to the trunk of the squad car and travel to the police station. Enter the homicide office. Check the In/Out basket. Read the note. Before visiting Marie, create a new file for the murder scene. Turn on the computer by inserting the computer access card and selecting the following functions:

- HOMICIDE*
- NEW FILE*

Turn off the computer and book the evidence using the case number you've just created:

- 199145

Enter the Booking Room. Place the evidence in the drawer. After all the evidence has been booked (under the new file number), travel to the hospital and visit your beloved wife. Look at the chart hanging at the foot of her bed. Check the setting of the IV. If the setting is incorrect, immediately summon a nurse by pressing the red button located on the wall above the headboard. After talking to the nurse and the doctor, show Marie how much you love her by giving her a kiss, then head on home and get some shut-eye.

DAY 5: ALL POINTS BULLETIN

Read the bulletin board, then use the computer to check the evidence analysis. Note the make and year of the automobile that matches the paint samples. Call dispatch and request an all-points bulletin on this vehicle. Use the computer and

POLICE QUEST 3

note the locations of the three murders and Marie's attempted murder:

- ❑ 199124 - 392 S. 6th
- ❑ 199137 - 280 W. Palm
- ❑ 199144 - 341 E. Rose
- ❑ 199145 - 376 W. Rose

Hint: *You must complete the next procedure correctly to progress in the game.*

Using the homicide computer, select *TOOLS*, then *CITYMAP*. Plot the locations on the road map by selecting *PLOT CRIMES*. Connect the crime locations using the drawing program and you'll see an incomplete pentagram. The fifth corner of the pentagram is the location of the next possible murder. This location is between 8th and 9th Avenues on Palm. If you've correctly plotted the murders, the game will inform you by a window. If you don't receive this window, try again. After creating the pentagram, power down the computer and open Officer Morales's desk using the duplicate key. Write down her locker combination—you'll need it later in the game:

- ❑ 386

Go to the Criminal Psychologist's office located directly across from the Briefing Room. Read Pat Morales's file. Leave the office. Travel to the location of the next possible murder:

- ❑ 250 E. Palm

THE OLD NUGGET SALOON

Get the scraper and evidence envelopes from the trunk of the unmarked squad car. Look at the suspect's vehicle. Scrape some paint from the rear quarter panel. Replace the scraper and any empty envelopes. Plant the tracking device under the suspect's vehicle. Save the game, then enter the saloon. Wait for the second

billiard player to appear. Click the eye cursor on him. Click the talk cursor on him and prepare to be shot at. *After* he displays a weapon, shoot to kill—just don't shoot prematurely. After the suspect has fled, get into the unmarked squad car. Turn on the flashing lights and the siren. Turn on the tracker located atop the dashboard. Follow the blip on the tracker. Travel down Highway 41 until you reach the accident scene.

THE ACCIDENT SCENE

Place road flares (which you took from the police storage locker) along the accident scene. Examine the victim and take the keys from the ignition. Search the victim. Talk to the paramedics. Open the trunk using the keys you removed from the ignition. Look at the packets of cocaine. Remember that there are five (5) packets in all. Leave the accident scene and travel to the station. Enter the homicide office and read the note in the In/Out basket. Book the evidence. Visit Marie and give her a kiss. This concludes Day 5.

DAY 6: THE CRACK HOUSE

Welcome to Day 6, the final day of the game. While in the homicide office, talk to the Captain. Travel to the first level. Talk to Mr. Stumps, the janitor. Enter the men's locker room. Create a diversion by placing a roll of toilet paper in the toilet. When the stall begins to flood, leave the locker room and tell the janitor about the flooding problem. Enter the women's locker room and find Officer Morales's locker. Open the locker using the combination you found in her desk (386). Note the packets of cocaine in her locker. Don't take them or Officer Morales will become suspicious. Rather, click your notebook on the packets. Leave the locker room and report your findings to the Captain. Travel to the coroner's office. Open the manila envelope and you'll find the following items:

- Cult ring
- Cult book
- Marie's locket

While waiting for the coroner, feast your curiosity by examining the bodies

POLICE QUEST 3

stored in the metal drawers. When the coroner appears, talk to him and he'll give you a news clipping. Drive to the hospital and check Marie's status. Give Marie the locket, then talk to her. Finally, give Marie a kiss and leave the hospital.

THE BURNING HOUSE

Get some envelopes and the scraper from the trunk of the unmarked police car. Talk to the fire chief. Enter the house. Find the photograph beneath a mound of burnt refuse. Look at the photograph and note the address: 522 Palm. Walk north into the alter room. Use the scraper to get a hair-and-blood sample. Replace the unused items in the trunk and leave the scene. When Officer Morales requests that you stop at the mall, exit the vehicle. Enter the Army Recruiter's office. Talk to the recruiter. Identify yourself by clicking your wallet on him. Show him the photograph of Michael and Jessie Bains. After the recruiter checks his database, take the printout of Bains's military record. Go back to the station and give this printout to the Criminal Psychologist.

Travel to the crack house at 522 Palm Avenue. Knock on the door. As expected, you won't get any response. Get a search warrant by driving to the courthouse and showing the judge the photograph. Travel back to the crack house. Unfortunately, even with a search warrant you won't be able to get in. Go back to the station and book the following items in as evidence:

- The sample of blood and hair.
- The photograph of Jessie and Michael Bains.
- The cult ring.
- The cult handbook

Drive to the courthouse and request the Ram Unit. Grab the judicial order from the judge's desk. Travel back to the crack house and draw your weapon. To do this, click the gun on Sonny. After the ram breaks down the door, enter the house. If someone shoots at you, return fire immediately. If someone surrenders, cuff 'em, then exit the crack house. Get the police dog. Follow Spike into the crack house. Under the cushion you'll find a remote control. Point the remote at the television set and press the button No. 8. This will open the fireplace. Enter the secret room with caution—there'll be someone waiting for you.

LOCATION OF OBJECTS

<input type="checkbox"/>	Bains's Profile	Criminal Psychologist
<input type="checkbox"/>	Batteries	Storage Locker
<input type="checkbox"/>	Bronze Star	Assault Scene
<input type="checkbox"/>	Business Card	Reporter (Assault Scene)
<input type="checkbox"/>	Calibration Chart	Glove Box (Patrol Car)
<input type="checkbox"/>	Car Keys	Accident Scene
<input type="checkbox"/>	Complaint Form	In/Out Basket
<input type="checkbox"/>	Computer Access Card	Mike Downs
<input type="checkbox"/>	Cult Book	Manila Envelope
<input type="checkbox"/>	Cult Ring	Manila Envelope
<input type="checkbox"/>	Doctor's Chart	Footboard of Marie's Bed
<input type="checkbox"/>	Driver's License	Murder Scene
<input type="checkbox"/>	Duplicate Key	Zak
<input type="checkbox"/>	Evidence Envelopes	Vehicle Trunk
<input type="checkbox"/>	Flares	Storage Locker
<input type="checkbox"/>	Flashlight	Sonny's Locker
<input type="checkbox"/>	Gold Chain	Marie
<input type="checkbox"/>	Hair Samples	Murder Scene
<input type="checkbox"/>	Judicial Order	Courthouse
<input type="checkbox"/>	Key	Morales's Purse
<input type="checkbox"/>	Knife	Deranged Suspect
<input type="checkbox"/>	Marie's Locket	Manila Envelope
<input type="checkbox"/>	Military Record	Army Recruiting Office
<input type="checkbox"/>	Music Box	Bedroom
<input type="checkbox"/>	Nightstick	Sonny's Locker
<input type="checkbox"/>	Notebook	Sonny's Locker
<input type="checkbox"/>	Nut's Keys	Nut's Clothing
<input type="checkbox"/>	Nut's Knife	Nut's Underwear
<input type="checkbox"/>	Nut's License	Nut's Clothing
<input type="checkbox"/>	Paint Transfer Sample	Murder Scene
<input type="checkbox"/>	Photograph	Burning House
<input type="checkbox"/>	Reminder Note	In/Out Basket
<input type="checkbox"/>	Remote Control	Crack House

POLICE QUEST 3

- Rose Flower Shop
- Scraper Vehicle Trunk
- Search Warrant Judge Simpson's Chamber
- Skin Samples Murder Scene
- Subpoena In/Out Basket
- Toothpicks Vehicle Trunk
- Tracking Device Loaner Cabinet (Third Floor)

MAPS

POLICE STATION (1ST FLOOR)

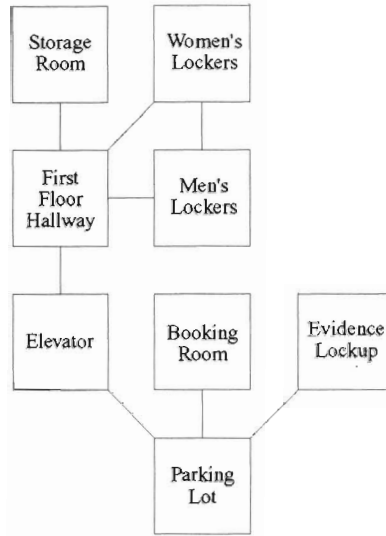

POLICE STATION (2ND & 3RD FLOORS)

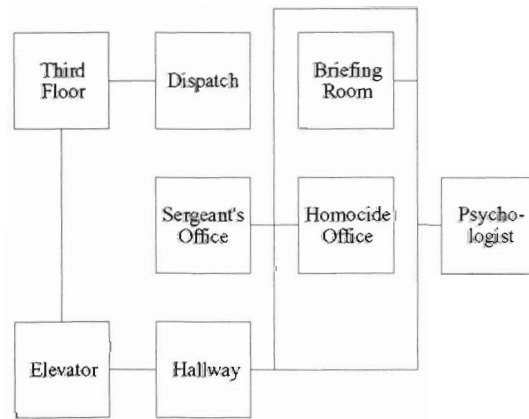

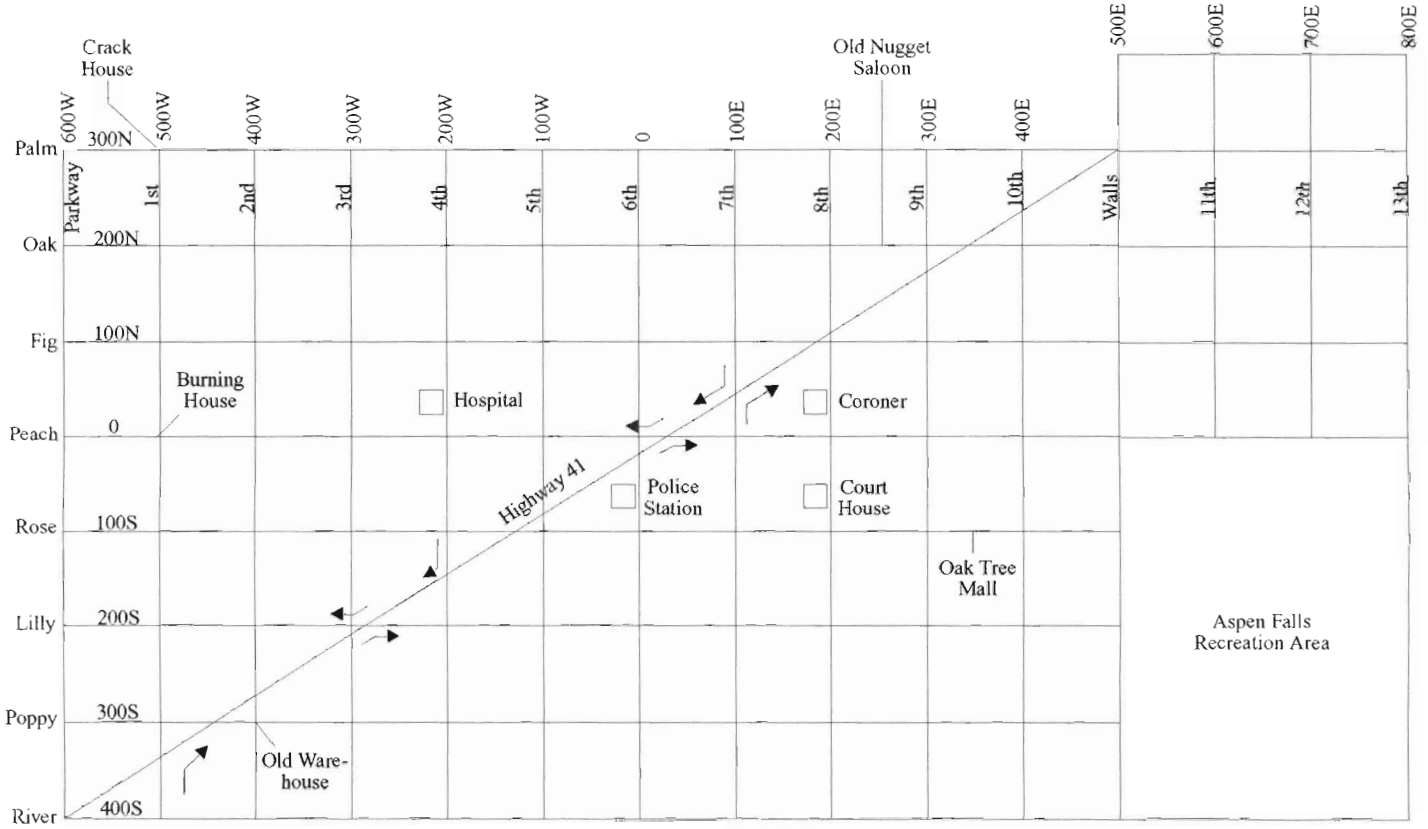

LYTTON

CHAPTER 18

INDIANA JONES

GRAPHICS:	☆☆☆☆	STORY LINE:	☆☆☆☆
ARCADE:	☆☆	INTERFACE:	☆☆☆
DIALOGUE:	☆☆☆☆	AUDIO:	☆☆☆
ANIMATION:	☆☆☆☆	LENGTH:	☆☆☆☆
OVERALL ANALYSIS: ☆☆☆☆			

SYSTEMS

- MS-DOS IBM-PC/Tandy & Compatibles
- Amiga
- Macintosh

FEATURES

- Point-'n-click your way through fistfights, puzzles, balloon rides, car chases, and Indy one-liners.*
- Hear LucasArts' exclusive iMUSE create a musical score that follows your every move.*
- Explore more than 200 spectacular locations.*
- Play and replay—three unique challenging paths to vanquish the Reich.*
- Play bumper cars with Gestapo kidnappers.*
- Repair an ancient doomsday machine . . . carefully.*
- Soar across the vast Sahara in search of mysterious ruins.*
- Capture a Nazi sub and find Atlantis's secret airlock.*
- Hot-foot it across a sizzling lava pit.*



SCENARIO

Every serious adventurer craves a game with a multitude of memorable scenes. *Indiana Jones and the Fate of Atlantis* by Hal Barwood of LucasArts truly indulges this appetite by including well over 200 vividly colored screens. The year is 1939 and you play the role of Indiana Jones (Harrison Ford). Your obsession is to uncover ancient artifacts and visit archeological dig sites to uncover the mysterious land of Atlantis. Prepare to capture and pilot a Nazi sub, soar across the Sahara in a hot-air balloon, and weave your way through a perilous labyrinth as you and your faithful (but reluctant) assistant, Sophia Hapgood, search for the Nazi agents who are trying to get their hands on a weapon more dangerous than the atom bomb. So tilt your hat forward, scratch your scruffy beard, and join Sophia as you try to unleash the deadly secret of the undersea village Atlantis.

WALK-THROUGH

BEFORE THE PATHS DIVERGE

Press Esc or click both mouse buttons to bypass the credits. From the opening scene, walk to the peculiar statue at the west end of the room. After falling through the trap door, click on the rope near the gaping hole. From within the library, click on the bookshelf located along the west wall.



Click on the cat figurines until you find the real feline. After falling down the coal chute, click on the lockers. In one of the lockers you'll find the mysterious statue (it will be in the last locker you choose).

NEW YORK CITY

Okay, you need to get into the theater and warn Sophia about the Nazis. Start by taking a newspaper. Walk around the building until you reach the side door. Now you have two options:

- Move the crates to gain access to the fire escape
- Fight the door attendant

***Note:** If you choose to fight the door attendant, you must strike the F key to invoke the numeric keypad for the fighting sequence. Also, Num Lock must be set to off.*

From within the theater, talk to the stagehand using the following responses:

- 2-3-1-1



Note: Due to random generation, the dialogue responses may vary.

Give the stagehand the newspaper and he'll walk away from the controls. To get Sophia's attention, push the left lever, then the right lever. Push the small red button. Use the following responses with Sophia:

❑ 3-4-4-1-2-1

ICELAND, THE AZORES, AND TIKAL

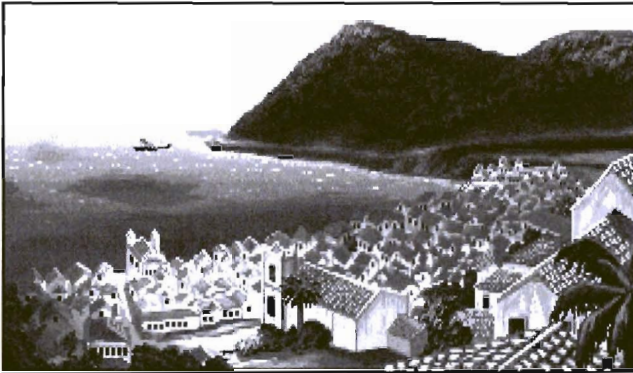

Your first visit to Iceland will result in gaining some clues for other destinations. Enter the old dig site and talk to Dr. Bjorn Heimdall using the following responses:

❑ 3-3-1-2-2-3-3-4

Heimdall will give you the names of two men who may aid in your quest, Costa and Sternhart. Visit Costa first. To get there, *USE* the truck, then click on The Azores icon. Knock on the door of the Costa home. Use the following responses with Costa:

❑ 1-3-4-1

After Costa slams the door in your face, talk to Sophia. Ask her to talk to Costa using the following dialogue responses:

❑ 1-1-2-1-1-1-1-1-1

Travel to Tikal. Walk east to enter the jungle. When you see the jungle rodent,

chase after it until it stops near the center path. Use the whip on the rodent. This will frighten the beast, forcing it to run toward the tree containing the snake. Use the tree to cross the canyon. To locate Charles Sternhart, walk to the temple. When he appears, use the following responses:

1-1-1-1-2-1-1-4

Talk to the parrot and ask about *Title*. The parrot will give you the correct title needed to enter the temple

Hermocrates

Approach the temple. When Sternhart appears, tell him you know the title and he'll allow you to enter the temple. Look at the animal head and the spiral designs. One of those designs has been etched deeper than the rest. You'll need kerosene to loosen this stone. A kerosene lamp hangs at the souvenir shop. Unfortunately, Sternhart doesn't want to part with it. To get the kerosene lamp, talk to Sophia and have her distract the doctor. Quickly sneak out of the temple and grab the kerosene lamp (*open* the lamp before using it on the spiral design). Pull the spiral design and place it in the animal head located along the west wall. Hey, doesn't that look like an elephant? Pull the elephant's trunk and the tomb will open.

Before leaving Tikal, get the shiny bead from the corpse. Close the tomb door. Travel back to Iceland and get the eel sculpture by placing the orichalcum bead into the eel's mouth. Use the truck to travel to the airport. Click on The Azores icon. Give the eel sculpture to Costa and he'll tell you that the Lost Dialogue of Plato can be found in the Ward collection at Barnett College in New York.

BARNETT COLLEGE

Before exploring the college for the Lost Dialogue of Plato, walk across the street and enter Indy's office. Open the icebox and retrieve the jar of mayonnaise. Enter the college and go upstairs.

Hint: If the staircase is blocked, you haven't completed all the puzzles necessary to continue.

The book you're looking for can be found at one of the following locations:

- Inside the fallen bookcase.
- Inside the wax cat.
- Inside the dusty chest behind the crate in the totem pole room.

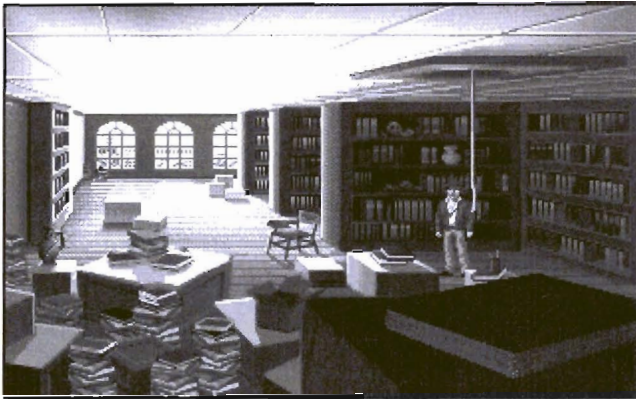

Get the wad of gum from the school desk in the library. Climb up the rope and find the arrowhead. Use the mayonnaise on the totem pole. Pull the totem pole until it rests beneath the hole in the ceiling. Climb the totem pole and find the urn. Open the urn. Among the ashes you'll

find a dusty key. You may open the chest after removing the candlestick, but you won't find a thing. Venture down to the basement. Get the dirty rag located on the crate near the stairs. Get a lump of coal. Use the gum to climb the slippery coal chute. Pick up the wax cat, then look at the fallen books. If they're from the Ward collection, you'll find the Lost Dialogue of Plato in the fallen bookcase. Use the arrowhead with the dirty rag to construct a crude screwdriver. Remove the screws from the back of the bookcase.

If the book isn't there, try placing the wax cat into the furnace. If you still haven't found the book, go to the totem pole room and push the large crate. Use the dusty key (which you found in the urn) to open the chest. After finding the Lost Dialogue of Plato, read every page marked with a paper clip (you'll be asked about it later). Leave Barnett College and enter Indy's office.

Now comes the part where you need to choose a path. Save the game (*F1*)

before proceeding any further. When communicating with Sophia, use the following responses:

- 2-1-1-1-2-3-2-2

The following example shows the three paths in random order:

- So it'll be rough. That is the way I like it.* (Action)
- I'd rather tackle this together with you.* (Team)
- I'd rather think my way through.* (Wits)



TEAM PATH: ALGIERS AND MONTE CARLO

So you think you can put up with Sophia? Well be forewarned—she's a real pain in the neck! Grin and bear it while traveling to Algiers. Once in town, walk as far west as you can go. Enter the back alley. Get the hanging mask and attempt to leave without paying for it. When the storekeeper stops you, use response No. 2 and he'll give you the mask for free. Leave Algiers and travel to Monte Carlo. When conversing with Sophia, use the following responses:

INDIANA JONES

❑ 4-2-1-1-2-3

After Sophia enters the hotel, find Alain Trottier. Trottier has gray hair and is wearing a brown suit. When you spot him, quickly move the cursor over Trottier and click the right mouse button. Use the following responses:

❑ 2-2-3-3

Answer Trottier's question correctly (the answer can be found in the *Lost Dialogue of Plato*) and he'll follow you into the hotel room. Choose response No. 2 with Sophia. As she performs the seance, grab the bed sheet and the flashlight (the flashlight's in the cabinet). Turn off the lights by pulling the circuit breaker. Combine the bed sheet, flashlight, and the mask to spook Trottier. Get the stone disk. Travel to Algiers and talk to the beggar using the following responses:

❑ 1-1-1

Enter the alley and walk to the souvenir shop. Talk to the shopkeeper (Omar) using the following responses:

❑ 1-1-3-1-3-2-1

Tell Omar the camels have died. Trade the mask for the red fez. Try giving the red fez to the grocer for a squab-on-a-stick. If he doesn't want the fez, go back to the souvenir shop and trade the fez for another item (bar of soap). Before giving the squab to the beggar, talk to the knife-thrower. Offer him your assistance and he'll tell you that his assistant must be a woman (show business, you know). Try convincing Sophia to assist the knife-thrower. Unfortunately, she'll want nothing to do with him. So give her a little push.

With the squab-on-a-stick and the bloody knife in inventory, approach the beggar and offer him food for a balloon ticket. To reach the balloon, use the staircase located directly behind the beggar. Give the balloon man the ticket. Enter the basket. Once you're aloft, cut the rope with the bloody knife. To maneuver the balloon, click on either *Vent hydrogen* or *Drop ballast* to change direction. To land, click continuously on *Vent hydrogen*. Land at a few nomad camps

and ask about the map, they (the nomads) will steer you in the direction of the dig site.

THE DIG SITE (TEAM PATH)

After a harsh landing, walk one screen west. Sophia will fall into a deep pit (I warned you about Sophia). After this happens, walk to the truck and examine the engine: It's missing a spark plug and the distributor cap. Climb down the ladder to enter the dark room. Adjust the brightness control knob (on your monitor) to its brightest position. This will make it easier to locate the objects necessary to start the generator.

Find the hose, then the clay jar. Walk back to the truck and siphon some gasoline. To do this, click the hose on the gas tank, then click the clay jar on the hose. When the jar is full, pick up the hose and travel back to the dark room. Walk over to the generator and remove the metal cap from the gas filler pipe. Pour in the gasoline. Click the on/off switch. After the lights go on, locate the ship rib and the wooden peg. Walk to the east wall and you'll notice that it appears to be crumbling. Use the sharp ship rib to access the mural. Do you see the tiny hole in the mural? Place the wooden peg in the hole. Place the Sunstone on the peg. Look at the Sunstone. Rotate the stone until the *setting sun* is on top. Press the peg and the secret door will open. If it fails to open, try a different setting.

After freeing Sophia, pick up the Sunstone and open the generator. Turn off the generator. Reach inside and you'll find a ceramic thing (spark plug). Get the spark plug, then leave the dark room. Place the spark plug and the distributor cap (which Sophia found) in the truck's engine. Use the truck to travel to Crete.

CRETE (TEAM PATH)

From the docks, walk west until you reach a suspension bridge. Cross the bridge. Walk west until you see the transit (surveyor's instrument). Place it in inventory, then search the ruins for a mural. After finding the mural, note the locations of the bull's head and the bull's tail—these are the locations where you must place the transit. Search the nearby rock piles to reveal the statues. Use the transit on one of the statues. Align the transit with the large bull horn as portrayed on the mural. If you've properly set and adjusted the transit, a dotted line will appear. Move the transit to the next statue and align it with the other large horn. After correctly aligning the transit with both large horns, an *X* will appear in the sand. Use the ship rib to dig up the Moonstone. Leave the ruins by walking east.

Welcome to the Labyrinth. To open the secret door, place the Sunstone and the Moonstone on the stone pedestal. The correct setting can be found in the Lost Dialogue of Plato on the pages marked by the third paper clip. Before entering the Labyrinth, pick up the stones.

THE LABYRINTH (TEAM PATH)

Save the game. Remove two of the head statues from the platform. Walk through the doorway. To get the third head, use the whip on it. Walk up the staircase and through the center doorway. Walk one screen east, one screen west. Welcome to the Minotaur statue room. Look at the statue's head—it appears to be loose. To remove the head, use the whip on it. Walk onto the platform that the statue head fell on. Surprise—it's an elevator.

Look at Sternhart's body. Take the staff and the third stone, the Worldstone. Also, read the note clutched in Sternhart's left hand. Before leaving the lower level, open yet another door. Walk through the north doorway and notice the hole above the door. Unfortunately, this hole is too small for you to fit through, so you'll need to convince Sophia to crawl into that bug-infested hole. Try using the following responses with Sophia:

❑ 2-3-2-3

Before entering the unexplored section of the lower Labyrinth, you'll need to find a lead-lined gold box. If you enter this section now, you'll only walk in circles. If I've convinced you to leave the lower level, you may be asking yourself:

❑ "How am I going to get back to the upper level?"

Look closely at the waterfall: There you'll find a hidden chain. You can climb this chain, but don't expect Sophia to follow. When you're back in the statue room, walk through the west doorway, being careful not to step on the elevator platform. Place the three statue heads on the platform to open the closed door. Walk up the staircase and through the center doorway. Walk one screen east and use the staff on the chock; this will free the counterweight. Leave this room by walking west, then north. Travel down the staircase and through the east

doorway. Continue through the rooms until you reach the colossal head statue.

To activate the elevator, look closely at the mouth of the statue—there you'll find a cleft. Use the staff in the cleft to trigger the elevator. Grab the gold box and the beads of orichalcum. Place the beads into the gold box and close it—otherwise, the orichalcum locator will detect only your own beads.

Travel to the lower section of the Labyrinth. Walk through the doorway that Sophia had unlocked earlier (the one with the hole). Use the fish on the string. Since Sophia's necklace uses orichalcum, it will affect the outcome of the locator. You must convince Sophia to place her necklace into the gold box. Use the following responses to convince Sophia to part with her precious bead:

❑ 3-3-1-1-1

After finding the secret passageway, use your handy ship rib to dig up the rubble. The next scene will be of a giant room containing a scale model of a city. Could it be a model of Atlantis? Use the stones on the peg, located in the center of the model, to open *one* of the closed doors. After passing through the open doorway, Kerner the Nazi will appear. Give him the stones by using the following responses:

❑ 2-1

To exit the locked room, find the section of wall that appears to be crumbling. Use the ship rib to remove the loose rocks.

THE SUBMARINE (TEAM PATH)

When you're on the deck of the Nazi U-boat, locate the hatch just above the decal of the boxing fish. When the Captain appears, use response No. 1. After defeating the Captain, enter the conning tower and pull the large yellow lever. Talk into the intercom using response No. 1. Go to the lower deck. Walk one screen west. Get some bread and some cold cuts, then combine these items to make a sandwich. Don't eat the sandwich, since you'll need it later in the game. Look on the shelf and you'll find a porcelain beer stein. Get the stein. Walk to the large, bronze-colored lever labeled

❑ *AUSGESCHNITZEL*

Push this lever and you'll have complete control of the submarine's speed. Move the lever to the lowest position to stop the ship. Exit the underwater scene. Push the switch located just to the left of the bronze lever. Exit the underwater scene. Walk west until you reach a trap door. Go to the lower level and walk two screens east. Gather the spilled battery acid using the beer stein. Continue walking east until you see Sophia next to a vent. Talk to Sophia (through the vent) using the following responses:

❑ 3-2

Go to the aft section and climb the ladder. Walk east until you reach the ladder leading to the room where Sophia's being held. Before attacking the guard, get the plunger. When the guard spots you, tell him that his future looks *pail*. After Sophia knocks the guard unconscious, climb the ladder. Walk east until you're standing directly above Kerner. Locate the nearest trap door and climb down the ladder. Locate the strongbox. Inside this box are the stone disks and a key. To get into the strongbox, use the battery acid on it. Take the stone disks and the key. Go back to the room where you left Sophia. Use the key to unlock the emergency rudder control. Push the wheel, then exit the underwater scene. Travel to the conning tower. Use the plunger in the broken lever and prepare to pilot a German U-boat. Pilot the sub toward the small black airlock of Atlantis, then back it in. Clues are continued in the section entitled *The Airlock*.

WITS PATH: ALGIERS AND MONTE CARLO

Travel to Monte Carlo and talk to Trottier (gaining his business card). Travel to Algiers. Walk west until you find the back alley. Take the north path to reach the souvenir shop. Approach the storekeeper and use the following dialogue responses:

❑ 1-1-3

Give the servant Trottier's business card, then follow him into the streets. Since the

population's enormous and everyone's wearing white, the servant's impossible to follow. But did you notice the man in the red fez? If you can obtain this fez and give it to the servant, you may be able to follow him. To get the fez, follow the man (in the red fez) until he reaches the market. Use the following responses:

❑ 4-3-1-3-1-2

Once you have the red fez, give it to the servant. Ask for another meeting with Mr. Al-Jabber and the servant will travel to Omar's house. Follow the servant closely: He's sneaky, but not impossible to follow. Eventually he'll lead you to Omar's house.

Enter the house and wait for Paul (the servant) to leave. Then enter the closet and Omar will follow you. Quickly close the closet door. While ignoring Omar's remarks, take both statues and the pole. Use the pole on the hanging cloth to get the map of the desert. Use the camel to leave the Al-Jabber home. Don't think that the desert is a safe place to be—there are many nomad police searching for full-bellied outlaws like yourself. If you happen to encounter one of these men, bribe them with the statues you stole from Omar's house. As you comb the desert, you'll encounter many nomad camps. Visit these friendly camps and ask about the map; the nomads will steer you in the correct direction.

THE DIG SITE (WITS PATH)

From the scene with the camel, walk one screen west. Forget about the camel—he's long gone. If you don't believe me, look for yourself. Fortunately, there's a truck at the abandoned dig site. Open the hood and examine the engine. You'll notice that a spark plug and the battery are missing. Open the driver's-side door and read the note. Climb down the ladder and enter the dark room. Adjust the brightness control knob on your monitor to its brightest setting. Locate the hose and the clay jar. Use these items to siphon gasoline from the truck's gas tank. When you're back in the dark room, walk over to the metal thing (generator). Remove the gas cap from the gas filler pipe. Pour in the gasoline. Push the on/off switch. Get the ship rib and place it in inventory. Walk over to the painting and push the stone disk. After the secret compartment opens, remove the statue. Travel back to the generator and open it. Turn off the generator and reach inside: There you'll find a ceramic thing (spark plug). Install the spark plug into the

INDIANA JONES

truck's engine. Use the orichalcum bead in the statue. Use the statue on the spark plugs and you're off to Monte Carlo. Locate Trottier and warn him about the telegram. Try the following responses:

❑ 1-2

Hint: Trottier may walk away in disbelief—be persistent.

After the Nazi agents capture Trottier, it's up to you to rescue him. Hop into your car and ram the Nazis' vehicle several times. Eventually you'll damage their vehicle and they'll be forced to flee on foot. Talk kindly to Trottier. He'll tell you where he threw the stone disk (the location's different in each game).

Take to the streets in search of the intersection Trottier mentioned. When you find it, look in the sewage drain. Open the drain and you'll find the Sunstone. Travel back to the hotel. Use the taxi to get to the airport. I'll see you in Thera.

THERA (WITS PATH)

Welcome to Thera. Talk to the port authority using the following responses:

❑ 3-2-2-1

Walk over to the crate and look closely at it:

❑ *One Standard Observation Balloon Bladder*

Try opening the crate. The port authority will tell you that an invoice is needed to claim the balloon. Before searching for the invoice, take the fish net. Walk one screen west, then north. Walk toward the mountains. Find the archeological dig site. Look at the open crate. Close the crate. Get the invoice for the balloon. Enter the cave. Walk through the west doorway and get the entrenching tool. Open the entrenching tool and you'll find a note from Sophia. Notice the open door directly behind you. Close it and the secret panel will open. Place the Sunstone on the peg. Set the stone and push the peg. Open the door and take the inscription

(if the door failed to open, try a different stone setting). Before leaving this room, take the Sunstone. To pass through the blocked doorway, use the entrenching tool. Travel back to the dock. Try to take the large basket. When the port authority resists, give him the inscription. Get the large basket. Now claim your balloon.

Combine the fish net, the basket, and the balloon. Travel to the natural gas fissure at the archeological dig site. Use the hose with the balloon. Fill the balloon with natural gas. Use the balloon to locate, and land on, the U-boat.

THE SUBMARINE (WITS PATH)

Open the hatch and climb into the conning tower. Use the ladder to reach the lower level. Walk west to the aft section and pass the guard wearing a green uniform. Get some bread and cold cuts. Combine these items to make a sandwich. Offer the sandwich to the guard. When he leaves his post, open the lockers and retrieve the Moonstone and the torpedo instructions. After the sub changes course, walk to the forward section and take the clothesline. Walk east and take the oily rag. Walk to the aft section and find the controls for the torpedoes. Use the torpedo instructions on the controls. Use the oily rag on the bundle of tangled wires. Push the launch lever to start a fire.

Quickly walk to the forward section. Use the torpedo instructions on the control panel. Tie the clothesline to the launch lever. Open the torpedo tube. Climb into the torpedo tube, plug your nose, and pull the clothesline.

THE LABYRINTH (WITS PATH)

Remove two head statues from the platform. Walk through the doorway. To get the third head, use the whip on it. Clamber up the staircase and through the center doorway. Walk one screen east, one screen west. Look at the statue's head. To remove the head, use the whip. Walk onto the platform that the statue head fell on.

Look at the dead body. Take the staff, wool scarf, and the third stone—the Worldstone. Also read the note clutched in Sternhart's left hand. Climb the chain behind the waterfall. From the statue room, walk through the west doorway. Place the three statue heads on the platform to open the closed door. Walk up the staircase and through the center doorway. Walk one screen east. Use the staff on the chock—this will free the counterweight. Leave this room by walking west, then north. Walk down the staircase and through the east doorway. Continue

through the rooms until you reach the colossal head statue. To activate the elevator, look closely at the mouth of the statue—there you'll find a cleft. Use the staff in the cleft to trigger the elevator. Grab the gold box and the beads of orichalcum. Place the beads into the gold box and close it—otherwise, the orichalcum locator (explained later) will detect only your own beads. After finding the microtaur, place the statue into the open hatch. Use an orichalcum bead in the statue to power up the microtaur. Follow the machine as it digs a tunnel.

The next scene will be of a giant room containing a scale model of a city. Use the stones on the peg, located in the center of the model, to open *one* of the closed doors. Walk behind the waterfall and through the east doorway. Place the orichalcum beads into the gold box and close it. To construct the orichalcum locator, combine the clothesline with the rubber comb, then statically charge the comb using the wool scarf. Use the charged comb and you'll find some orichalcum beads under the decaying bones. Place these beads into the gold box. Leave this room and use the charged comb in the room with the waterfall. Use the entrenching tool to locate the hidden doorway. Before operating the subway car, pick up the orichalcum bead lying near your feet. Place this bead into the mouth of the subway car. See *The Airlock* for additional clues.

ACTION PATH: ALGIERS AND MONTE CARLO

If you've chosen the action path, travel to Monte Carlo and locate Trottier—he has gray hair and is wearing a brown suit. Answer his question correctly and he'll give you his business card. If you don't know the answer to his query, read the *Lost Dialogue of Plato*. After acquiring Trottier's business card, travel to Algiers.

Welcome to Algiers. Walk west. Take the north path to reach the souvenir shop. Approach the storekeeper and use the following dialogue responses:

❑ 1-1-3

Give the servant Trottier's business card. When he leaves his store, follow him into the city streets. Since he's wearing a red fez, he'll be easy to spot among the vast crowd. Follow him closely—he's sneaky, but not impossible to follow.

Eventually he'll lead you to Omar's house. Enter the house and approach the guard. After you defeat the guard and Omar has left, take both statues and the pole. Use the pole on the hanging cloth. Get the map of the desert. Use the camel to leave the Al-Jabber home. While combing the desert, defeat any nomad police you encounter. Visit the friendly nomad camps and ask about the map. The nomads will steer you in the direction of the dig site.

THE DIG SITE (ACTION PATH)

Walk to the truck and examine the engine. Unfortunately, the carburetor has been stolen, rendering the vehicle useless. Climb down the ladder and enter the dark room. Adjust the brightness control knob (located on your monitor) to its brightest position. Locate the generator and activate it by pushing the on/off switch. Get the clay jar, the ship rib, and the wooden peg. Walk to the painting on the west side of the room. Push the stone disk. When the secret compartment opens, get the Sunstone.

Have you noticed that the east wall appears to be crumbling? Use the sharp ship rib to access the mural. Place the wooden peg in the hole. Place the Sunstone on the wooden peg. Look at the stone. Rotate the stone until the *setting sun* is on top, then press the peg and the secret door should open. If the door failed to open, try a different stone setting. Walk through the secret opening and you'll be spotted by a Nazi guard. Try using the following responses with the Nazi guard:

❑ 1-2-1-2

If that doesn't work, *use* the whip on the guard. After defeating the Nazi, locate the rope ladder leading to the hot-air balloon. Maneuver the balloon over the ocean and you'll automatically travel to Crete.

CRETE (ACTION PATH)

See *Crete (Team Path)*.

THE LABYRINTH (ACTION PATH)

Refer to *The Labyrinth (Wits Path)* for general clues in the labyrinth. After solving those puzzles, walk into the room with the stone slab covering the doorway—this room is located one screen east of the room containing the

Minotaur statue. To open the door, push on it several times. Eventually it will give way. To cross the gaping hole, use the whip on the stone outcropping. Walk through the northernmost doorway. Hide behind the first stone slab. Push the slab on the guard. Walk north and you'll encounter Franz. Defeat Franz with your fists, then walk up the staircase. Enter the rooms in a clockwise manner while defeating anyone that crosses your path. Eventually you'll reach a balcony. Look down at Anton. Notice the stalactite at the east end of the balcony. Push it and it will crush Anton. Get the stalactite. Travel east until you find the large boulder. Use the ship rib to dislodge the boulder from its holding position. The ship rib will break and the boulder will tumble in the wrong direction, blocking the doorway.

After giving Arnold a song title that he likes, walk to the doorway (where the boulder's lodged) and use the stalactite. This time the boulder will travel in the correct direction, landing on Arnold. Look at Arnold and you'll find some orichalcum beads and a fish on a string (orichalcum detector). Place the orichalcum beads into the gold box and close it. To locate Sophia, use the fish on a string and it will point to the pit. When you finally have Sophia's attention, use the whip to free her. She'll give you the third stone disk. Enter the map room by walking west. Use the stones on the peg to open *one* of the closed doors. I'll see you in Thera.

THERA (ACTION PATH)

Welcome to Thera. Begin by using response No. 1 with Sophia. Walk west, then head toward the mountains. Locate Kerner's jeep. Directly in front of his vehicle is a tire repair kit. Get the repair kit, then travel back to the docks. Talk to the Captain. Find the location of Atlantis in the Lost Dialogue of Plato. Subtract 100 from the distance given. The location of Atlantis is

❑ 18 miles southwest of Thera

After reaching your destination, open the storage locker and use the tire repair kit on the punctured diving suit. Connect the air-hose to the suit and turn on the air compressor. Use the suit and have Sophia *hoist* you into the water. After a short animated sequence, you'll be many leagues below sea level—without an air supply. Save the game, then search for the airlock leading to Atlantis.

THE AIRLOCK

Another dark room (grunt). Being the faithful reader you are, you already know how to deal with dark rooms (by adjusting the brightness control knob of the monitor). Locate the wood thing (ladder) and place it in inventory. Walk east and locate the stone rubble—a perfect place to put the ladder. Climb the ladder and find the stone cabinet. Get the light wand. Place an orichalcum bead into the wand. Take the ladder. Walk to the sentry statue and place the stone disks on the spindle. Set the stones as you have throughout the game. But before pressing the spindle, turn each stone 180 degrees. When the mouth of the sentry statue opens, you've entered the correct stone combination. To open the door, place an orichalcum bead in the mouth of the sentry statue.

Hint: *Before leaving the airlock, take the stone disks and the ladder.*

THE OUTER RING

If you think this is just another maze puzzle needing to be solved, you're right—and wrong. You do need to get through the maze. You must visit the rooms within the maze and solve each room's puzzles before you'll be allowed to continue. Since the game shuffles the locations of the rooms, you'll need to find them on your own. Once you find a room, the name of that room will appear in place of the question mark.

Hint: *While in the outer circle, you DO NOT have to manually maneuver through the maze. Just click the cursor on the location you wish to visit and your character will automatically take the shortest route.*

Travel from room to room (defeat a Nazi guard to gain his food rations). If you see a grate, open it and crawl through the ventilation system—it may lead to another room. As you journey from room to room, obtain the following items:

INDIANA JONES

- Bronze gear
- Statue of a fish head
- Eel sculpture
- Tin cup
- Bronze spoke wheel
- Human rib cage

The bronze gear and the spoke wheel can be found in the rooms containing robot parts. The statue of the fish head and the eel sculpture can be found in one of the rooms in the outer circle. The tin cup can be obtained from the statue room (use the ladder to cross the gaping hole). The rib cage can be found at the subway (the subway can be reached by traveling along the outermost path).

Among the many rooms you'll visit, one will contain an air vent leading to the dungeon where Sophia's being held. If you're at the vent next to the sentry statue, place an orichalcum bead into the statue's mouth and it'll kill the guard.

CRAB CENTRAL

If you have the following items, you're ready to catch a crab:

- Human rib cage
- A sandwich or Bratwurst

Place the bait into the rib cage and submerge the device into the pool of water. When you hear a snap, retrieve the caged crab.

THE LAVA ROOM

If you have the statue head of a fish and the tin cup from the statue room, you can visit the lava room. Place the tin cup on the pedestal. Place the statue head on the plaque. Remove the cup of hot lava.

THE MACHINE ROOM

If you have the hot cup of lava and the bronze wheel, you can visit the machine room. Place the spoke wheel on the sprocket. Pour the hot lava into the funnel. Get the beads from the dish—and don't forget to take the spoke wheel.

THE SENTRY ROOM AND THE DUNGEON

Do you have the eel sculpture? If so, place an orichalcum bead into the eel's eye and toss it into the water. The heat from the eel will vaporize the water, thus allowing the mechanism to open the door. Drop an orichalcum bead into the mouth of the fish statue and the double doors will open. Before entering the canal, visit the dungeon. There you'll find Sophia—who, by the way, is looking better than ever. Get the statue part from the sentry statue. (Before you can free Sophia, you must conquer the canal.)

THE CANAL

To make friends with the octopus, give him the crab in the trap (rib cage). To cross the canal, just walk to it. Climb aboard the crab-like raft. Place an orichalcum bead into the crab's mouth and float west. To open the first gate, place the Sunstone on the spindle. To open the next gate, use the Moonstone, and so on. When you reach the room with the doorway, float to the landing. Climb the staircase along the east wall. Get the crescent-shaped gear from the cupboard, then close the cupboard to reveal a mural. Walk back to the crab-like raft. Open the gate with the Worldstone. Enter the archway and look at the sentry statue (doomsday machine).

To repair the doomsday machine, connect the chain to the bronze loop attached to the door. Use the ladder on the sentry statue to reach the chest plate. Push the chest plate and examine the mechanism. You'll need five machine parts to complete repairs. Use the following instructions to repair the sentry statue:

- Place the spoke wheel on the center peg.
- Place the silver part on the center peg.
- Place the crescent-shaped part on the right two pegs.
- Place the small gear on the upper-left peg.
- Place the orichalcum bead in the center hole.

After the robot's arm moves forward, connect the chain to the bronze loop. Retract the robot arm by moving the small gear to the lower-left peg. Place another orichalcum bead in the center hole. Before entering the inner circle, get the hinge pin and the ladder, then go back to the dungeon and free Sophia.

THE DUNGEON

To free Sophia, you first must solve all the puzzles in the canal. Also, an orichalcum bead must be placed into the statue's mouth (from behind the vent) to kill the guard. Once these procedures have been performed, give Sophia the hinge pin. Pick up the gate. Tell Sophia you have a plan: She should use the hinge pin to brace the gate. After freeing Sophia, pick up the gate and take the hinge pin.

INNER RING

Follow Sophia into her humble abode. Walk west, past the lava pit. Walk up the staircase and take the scepter. Look at Sophia. Place an orichalcum bead in the mouth of the medallion. After it heats up, Sophia will remove it from her neck. Use the gold box on the necklace, then toss it into the lava pit. Leave this room and find the room with the giant hulking machine. To operate it, place the hinge pin in the left slot. Place the scepter in the right slot. Place an orichalcum bead in the mouth of the figurine. Push both levers and prepare yourself for one hell of a ride. When you find yourself on an endless loop, pick up the hinge pin from the left slot and place it in the center slot. Push the center lever. Pull the right lever twice.

THE LAVA PIT

The object is to get to the lowest level, then cross the lava pit. Venture through the rooms. When Indy says "Whoops," you're on the right path. As you travel from room to room, look at the large mural on the far wall. Note the location of the sun, the moon, and the volcano. When crossing the lava pit, watch out for the small eruptions. Save the game. Use the trial-and-error method to cross the lava pit (don't worry, it isn't that tough). Walk east and you'll reach a shining city. Place the stones on the spindle and rotate them to mimic the giant mural. After Kerner appears, use the following responses to win the game:

❑ 3-3-1-2-2-2-1-1-1-1-2-1-4-3-2-1

LOCATION OF OBJECTS

- Arrowhead Barnett College
- Balloon Bladder Thera
- Balloon Ticket Beggar
- Bar of Soap Omar
- Basket Thera
- Battery Acid U-boat
- Bed Sheet Hotel Room
- Bloody Knife Knife Thrower
- Bread U-boat
- Bronze Gear Labyrinth
- Bronze Spoke Wheel .. Labyrinth
- Business Card Trotter
- Camel Omar's Home
- Clay Jar Dark Room No. 1
- Clothesline U-boat
- Coal Coal Chute (Barnett College)
- Cold Cuts U-boat
- Comb Sternhart
- Crab Crab Central (Rib Cage)
- Crescent-shaped Gear Canal
- Desert Map Omar's Home
- Dirty Rag Crate (Coal Chute)
- Distributor Cap Sophia
- Diving Suit Storage Locker (Fishing Boat)
- Dusty Key Urn (Barnett College)
- Eel Sculpture No. 1 Iceland
- Eel Sculpture No. 2 Labyrinth
- Entrenching Tool Thera
- Fish Net Thera
- Flashlight Cabinet (Hotel Room)
- Gold Box Labyrinth
- Gum School Desk (Barnett College)
- Hinge Pin Sentry Statue
- Hose Dark Room No. 1
- Human Rib Cage Labyrinth
- Inscription Thera
- Invoice Closed Crate (Thera)
- Kerosene Lamp Souvenir Shop (Temple)
- Key (rudder control) U-boat
- Ladder Dark Room No. 2
- Lava Lava Room (Tin Cup / Spoke Wheel)
- Light Wand ... Dark Room No. 2
- Lost Dialogue of Plato Barnett College
- Mask ... Souvenir Shop (Algiers)
- Mayonnaise Icebox (Indy's Office)
- Moonstone Ruins / U-boat
- Mysterious Statue Barnett College
- Newspaper New York
- Oily Rag U-boat
- Orichalcum Beads Labyrinth
- Plunger U-boat
- Pole Omar's Home
- Red Fez Omar / Servant
- Scarf Sternhart
- Scepter Inner Ring

INDIANA JONES

- Shiny Bead Tomb (Temple)
- Ship Rib Dark Room No. 1
- Spark Plug Generator
- Squab-on-a-Stick Grocer
- Staff Sternhart
- Stalactite Labyrinth
- Statue Heads Labyrinth
- Statue of Fish Head Outer Circle
- Statue Part Dungeon
- Statues Omar's Home
- Stein U-boat
- Sunstone Hotel Room / Drain
- Tin Cup Labyrinth
- Tire Repair Kit Thera
- Torpedo Instructions U-boat
- Transit Ruins (Crete)
- Wooden Peg Dark Room No. 1
- Worldstone Sternhart

MAPS

TEAM PATH

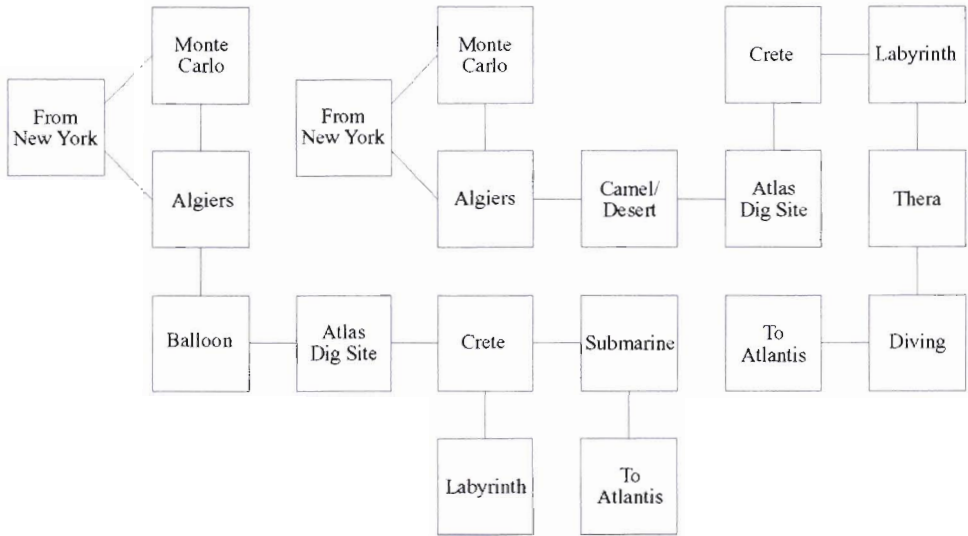

FISTS PATH

WITS PATH

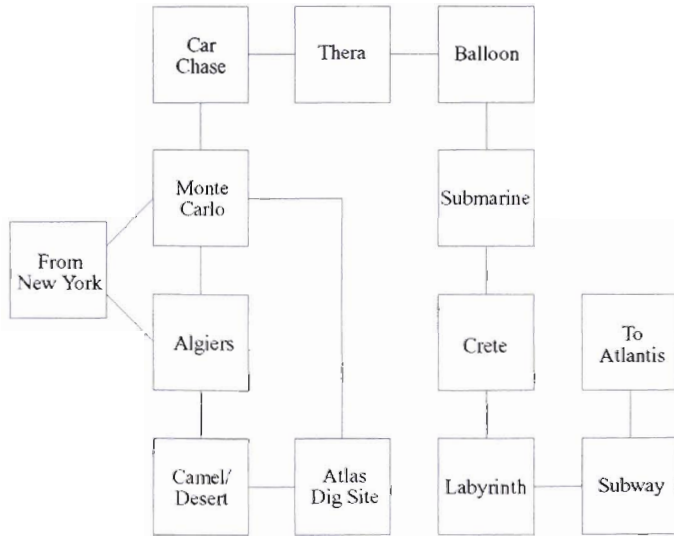

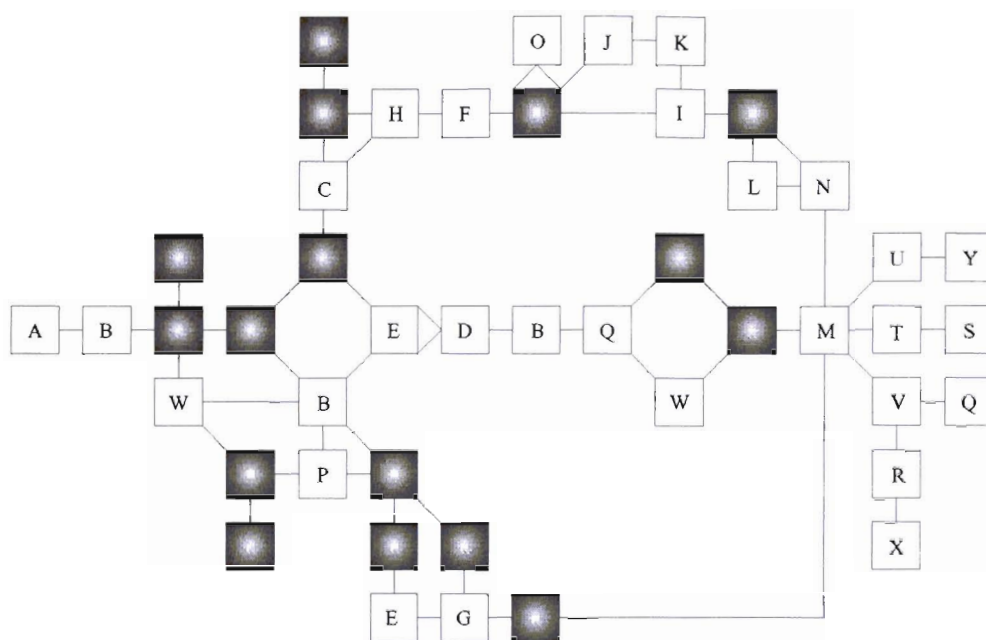

LABYRINTH

- | | |
|----------------|-------------------------|
| A= From Crete | N= Singing Arnold |
| B= Bronze Gate | O= Otto |
| C= Chasm | P= Pond |
| D= Corpse | Q= Orichalcum |
| E= Elevator | R= Rapid Transit |
| F= Franz | S= Submarine |
| G= Gold Box | T= Team Path |
| H= Hans | U= Fists Path |
| I= Anton | V= Wits Path |
| J= Kurt | W= Waterslide/Waterfall |
| K= Karl | X= To Atlantis |
| L= Boulder | Y= To Thera |
| M= Map Room | |

CHAPTER 19

THE LEGEND OF KYRANDIA

GRAPHICS:	☆☆☆	STORY LINE:	☆☆
ARCADE:	N/A	INTERFACE:	☆☆☆
DIALOGUE:	☆☆	AUDIO:	☆☆
ANIMATION:	☆☆☆	LENGTH:	☆☆☆
OVERALL ANALYSIS: ☆☆☆			

SYSTEMS

- MS-DOS IBM-PC/Tandy & Compatibles
- Macintosh

FEATURES

- More than 100 brilliantly rendered scenes.*
- Captivating soundtrack.*
- Fluid and realistic animation.*
- Four chapters of progressively more challenging quests.*
- Elegant point-and-click interface makes Kyrandia simple to master and a joy to play.*

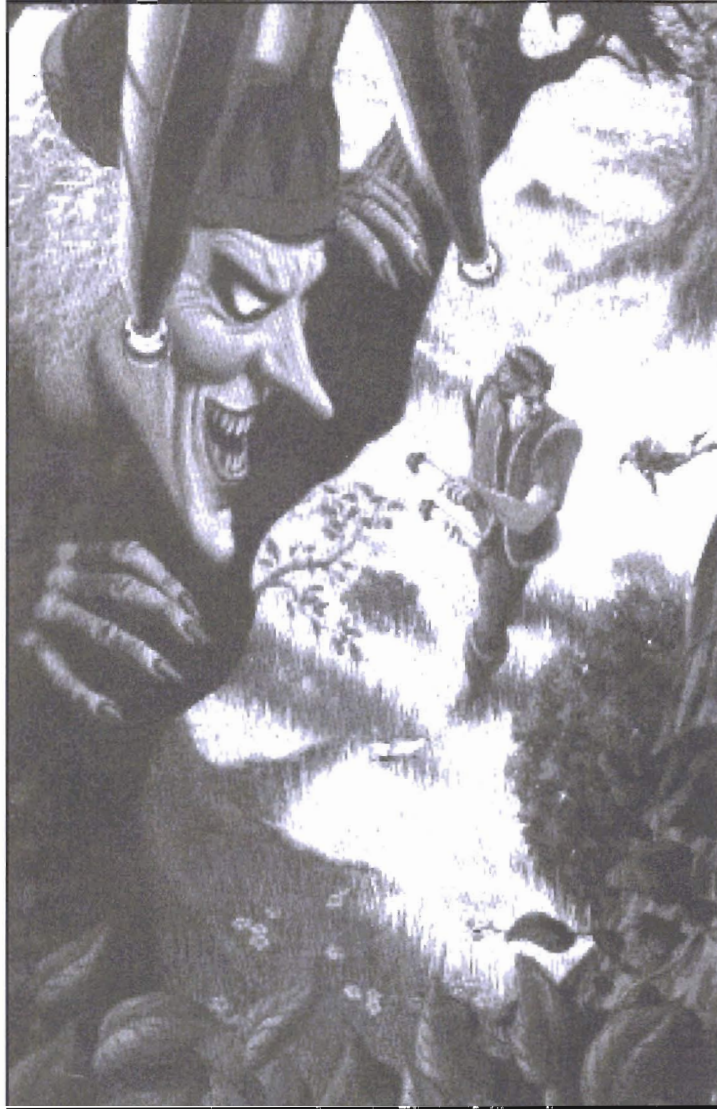

SCENARIO

The Legend of Kyrandia, first in the *Fables and Fiends* series, was created by Westwood Studios and is distributed by Virgin Games. Slightly similar to Sierra's ever-popular *King's Quest* series, *Kyrandia* is a celestial adventure that takes you into a magical land where rubies grow on trees, altars glisten with magic, and tiny forest sprites linger. You're the chosen Prince who must protect the Order of Royal Mystics from falling into

the evil clutches of the usurper Malcolm. Divided into four chapter-like episodes, *Kyrandia* increases in difficulty as the game progresses. The possibility of death exists, but not as eminently as in a Sierra game. Although this game allows you to advance without having the appropriate items in inventory, it's quite easy to backtrack (if you utilize my maps, that is). If you're a die-hard *King's Quest* fan, you'll undoubtedly enjoy the jocose chapters of *Kyrandia*.

WALK-THROUGH

CHAPTER ONE: BRANDON'S HOME

The game begins in Brandon's home. Get the apple from the purple vase. Eat the apple. Place the apple core in the purple vase. Get the note from the desk and place it in inventory. Get Grandfather's saw and place it in inventory. Also get the Garnet. Now exit the tree house.

THE WEEPING WILLOW TREE

Walk two screens east and take a teardrop. Walk east and get the Peridot. Walk four screens west. Place the teardrop into the indentation of the willow tree. When little Merith appears, chase him from screen to screen. When you lose sight of him, walk north and get the marble.

THE FOREST ALTAR AND THE TEMPLE

From where you found the marble, walk one screen east and you'll find the forest altar. Pick a lavender rose and place it in inventory. Place the marble on the altar. Walk one screen west, one screen south, five screens west, and one screen north. Enter the Temple of Kyrandia. Talk to Brynn. Give Brynn the note. Read the note. Give Brynn the lavender rose. Take the silver rose and exit the temple. Travel back to the forest altar (Amulet) by walking one screen south, five screens east, one screen north, and one screen east. Place the silver rose on the altar.

THE BROKEN BRIDGE

From the altar, walk one screen west, then south until you reach a cavernous opening. Pick up any gems that you encounter along the way. Enter the cave and talk to Herman. Give Herman the saw. While he's busy fixing the bridge, venture throughout the forest. Upon your return, the bridge will be fixed. Cross the bridge. This concludes Chapter One.



CHAPTER TWO: THE QUILL AND THE CARDINAL

After crossing the bridge, walk due west. Enter the strange-looking hut. Once inside Darm's abode, talk to him. He'll ask you to find a quill (feather).

Note: Because of random generation, the items may be at locations other than the ones indicated here.

Exit the hut, then walk one screen south and one screen west. Get the walnut. Look at the cardinal: His wing was injured by Malcolm's evil magic. Before you can heal the cardinal, you must find (and plant) the following:

- An acorn
- A walnut
- A pine cone

To find the acorn, begin at the scene with the cardinal and walk three screens west. Take the acorn. Walk one screen south and one screen east. Here you should find a pine cone. To plant these seeds, you must find a deep hole. The hole's located one screen south, two screens east, and one screen south from where you found the pine cone. Place the acorn, the walnut, and the pine cone into the deep hole.

The Pseudobushi Hugiflora (whatever that is) will grant you the magical power of healing (yellow jewel). Before healing the cardinal, visit the malicious Malcolm himself. Walk east until you reach the Serpent's Grotto. Enter the cavernous opening and Malcolm will appear. When Malcolm hurls a knife at you, quickly throw it back—if you hesitate, you'll die. Now heal the cardinal by walking two screens west, one screen north, one screen west, and one screen north. Talk to the old man, then walk one screen north and one screen east. To heal your feathered friend, click on the yellow jewel (located at the lower-right portion of the screen). Get the feather and travel back to Darm's abode by walking one screen west and one screen north. Give the feather to Darm and take the magic scroll. Darm will give you another puzzle to solve: find his birthstones and place them, in order, into a golden platter. Exit Darm's hut.

THE BIRTHSTONE PUZZLE

To find the Sunstone, begin at Darm's hut and walk one screen south, one screen east, one screen south, and one screen east. Click on the bubbling spring and place the Sunstone in inventory. Take a Tulip.

Hint: Pick a tulip: It'll come in handy later in the game.

Travel three screens west and two screens north. Pluck a ruby from the tree. After being bitten by a venomous viper, cure Brandon by clicking on the magic jewel for healing. Explore the forest (including Timbermist) and locate an Aquamarine gem and a Sapphire. Once these stones are obtained, travel to the marble altar containing a golden dish. Place the following gems into the dish consecutively:

- Sunstone
- Aquamarine
- Sapphire
- Ruby

Get the flute and play it twice. Travel back to Darm's abode. Talk to Darm and he'll tell you about the deep channels of the labyrinth.

SERPENT'S GROTTO

Exit Darm's hut and travel to Serpent's Grotto (one screen south, one screen east, one screen south, one screen east, two screens south, and one screen east). Toot the flute to crack the wall of solid ice. Before entering the labyrinth, save the game.

CHAPTER THREE: THE LABYRINTH

Enter the labyrinth and walk four screens east. To get through the labyrinth, you must make use of the fireberries. Place these special light-producing berries into the rooms needing illumination. Once placed on the ground, the berries will burn

THE LEGEND OF KYRANDIA

indefinitely. If carried in Brandon's inventory, however, they'll burn out after three screens (you may want to save the game at every fireberry bush, or refer to the map at the end of this chapter). As you venture through the labyrinth, you must find the following items:

- Five rocks
- A gold coin
- An iron key

The rocks and the gold coin can be found in one of the rooms in the labyrinth. The iron key is located at the subterranean, volcanic river (refer to the map at the end of this chapter). Use the magic scroll to cool the volcanic river.

Hint: Don't attempt to cross the river before using the magic scroll.

When you have the items mentioned above, place (throw) the rocks onto the counterweight platter near the entrance of the labyrinth. Exit the labyrinth. Locate the ancient well in Timbermist. Throw the coin into the well and place the Moonstone in inventory. Before reentering the labyrinth, you must have the following items in inventory:

- Tulip
- Sapphire
- Topaz
- Garnet
- Moonstone
- Magic scroll
- Iron key

Enter the labyrinth and travel to the Pantheon of Moonlight. Place the Moonstone in the opening of the pedestal. Click on the Will-O-Wisp jewel and float through the labyrinth until you reach the Chasm of Everfall. Float across the chasm, then float east to conclude Chapter 3.

CHAPTER FOUR: ZANTHIA'S LABORATORY

Get the apple and walk two screens east. After a log knocks you unconscious, you'll awaken in Zanthia's laboratory. Place the empty flask in inventory. Exit Zanthia's place.

THE ENCHANTED FOUNTAIN

From the laboratory, walk two screens west and you'll find the Enchanted Fountain. Malcolm, the court jester, will remove one of the crystal balls, thus rendering the magic fountain useless. You must find the crystal ball and restore the magic of the fountain.

To find the crystal ball (beginning at the fountain), walk two screens west, two screens south, one screen west, and two screens north. Extinguish the flames using the magic scroll. Get the crystal ball. Retrace your steps to the Enchanted Fountain and place the crystal ball on the empty pedestal. Use the flask to gather some magic water. Travel east to reach Zanthia's laboratory. Give Zanthia the magic water and she'll ask you to find some freshly picked blueberries. Get the empty flask and exit Zanthia's place. Walk west until you reach the fountain. Fill the flask with magic water. Drink the magic water and the blue jewel will glow.

THE BLUEBERRIES AND THE ORCHIDS

To find the blueberry bush (from the Enchanted Fountain), walk two screens west, two screens south, one screen west, one screen north, three screens west, and one screen north. Pluck some blueberries. Retrace your steps back to the Enchanted Fountain. Walk east to reach Zanthia's place.

Before attempting to concoct the magic potions, you'll need a couple of orchids. To find the orchid plant, exit Zanthia's (via the trap door beneath the lumpy rug) and walk three screens east, then north until you reach the tropical lagoon. Pick two (2) orchids. If you don't have enough room in inventory for the orchids, drop the flute—you no longer need it. Retrace your steps back to Zanthia's laboratory.

THE POTIONS

To create the magic potions, follow these instructions precisely:

- ❑ Place the tulip and the Topaz into the cauldron. Fill an empty flask with the yellow potion.
- ❑ Place the Sapphire and the blueberries into the cauldron. Fill an empty flask with the blue potion.
- ❑ Place the Garnet and one (1) orchid into the cauldron. Fill two (2) empty flasks with the red potion.

Hint: If you need empty flasks, exit, then reenter Zanthia's laboratory. An empty flask will appear each time you do this.

Once you have these potions, you can exit Zanthia's laboratory via the trap door. To reach the Crystals of Alchemy, walk three screens east, four screens south, three screens west, and one screen north. Place the yellow potion in one of the Crystal's indentations. Place the red potion in the other imprint. Get the orange (flying) potion. Repeat this procedure using the blue and red potions. Get the purple (shrinking) potion. Retrace your steps back to Zanthia's laboratory. Exit Zanthia's abode through the front doorway. Walk west until you reach the Enchanted Fountain. Walk one screen west and one screen south.

THE ROYAL CHALICE

To get the chalice, click on the blue jewel. Unfortunately, a little forest creature will snatch the chalice right out of your hands. Follow him by walking one screen east. Notice the small door in the tree. To get inside, drink the purple (shrinking) potion. Give the apple to the little creature. Exit the tiny dwelling and get the chalice from behind the large tree.

THE TROPICAL LAGOON

It's time to leave the forest. Travel to Zanthia's laboratory by walking one screen north and two screens east. Open the trap door. Walk three screens east, then north until you reach the tropical lagoon. If you have an orchid in inventory, step onto the platform and drink the orange (flying) potion. I'll be waiting for you on

the Dark Island.

THE DARK ISLAND

Welcome to the Dark Island, home of Castle Kyrandia. Follow the path by traveling east. Place an orchid on your parents' grave. After pontificating with your dead mother, the red (invisibility) jewel will glow. You now have all the magic needed to defeat the court jester, Malcolm.

CASTLE KYRANDIA

Walk east, then north until you reach a high bluff. Approach the castle gates. Click on the red (invisibility) jewel. Place the iron key (which you found in the labyrinth) into the keyhole. Enter the castle. Save the game.

THE REVOLVING FIREPLACE

From within the foyer, walk one screen west, then north until you reach a small study with an evil-looking fireplace. Approach the fireplace. To your surprise, it revolves. Notice the Royal Crown on the blind side of the fireplace.

Enter the dank dungeon passageway. Walk two screens west, one screen north, one screen west, two screens north, then due east. Click on the blue jewel to disable the force-field. Walk one screen north and one screen west. Remove the loose flagstone and take the key. Retrace your steps back to the study.

To get the Royal Crown, you'll need to *open* the fireplace without ending up on the other side. To accomplish this, you must move the books in the correct order. Look at the first letter of each title. Move the appropriate books to spell the word

❑ OPEN

If you move the wrong books, you must move them back to their original positions—otherwise, the fireplace won't turn. Get the Royal Crown and exit the study. To reach the foyer, walk one screen south and one screen east.

THE KEYS TO THE ROYAL FOYER

You'll need two keys to open the doors leading to the Royal Foyer. You already

THE LEGEND OF KYRANDIA

found the first key under the loose flagstone in the dungeon. So let's find the second key. Beginning at the foyer, clamber up the staircase. Then walk one screen west, one screen north, and one screen west. When you encounter Herman (who appears to be a bit under the weather), click on the yellow jewel to heal him. Walk past Herman (west). To reveal the key, you must play the bells in the correct order. Get the gong and strike the bells as follows:

- Green
- White
- Gold
- Silver

After the painting moves, get the key and place it in inventory. Exit the bedroom.

THE ROYAL SCEPTER

To find the Royal Scepter (from the bedroom), walk one screen south, one screen east, and one screen south. From the foyer, walk one screen east, two screens north, and one screen east. Get the Royal Scepter located along the east wall.

THE ROYAL FOYER

To reach the lower level of the Great Hall, start at the kitchen and walk one screen west, one screen south, and one screen west. Approach the double doors located along the north wall. Open the doors using both keys and enter the Royal Foyer. Save the game. Place the Royal Scepter on the first pedestal containing a red pillow. Place the Royal Crown on the center pedestal. And finally, place the Royal Chalice on the third pedestal.

THE CHAMBER OF THE KYRAGEM

Immediately walk in front of the mirror located along the east wall. Malcolm will enter the chamber and prepare to cast the stone spell at you. When he does, click on the red (invisibility) jewel. The spell will reflect off the mirror, striking Malcolm. Congratulations—you've survived *Kyrandia*.

LOCATION OF OBJECTS

- Acorn Random Location in Forest
- Apple Brandon's Home
- Blueberries Blueberry Bush in Forest
- Crystal Ball Behind Flames in Forest
- Empty Flasks Zanthia's Laboratory
- Fireberries Labyrinth
- Flute Golden Bowl
- Gems Random Locations in Forest
- Gold Coin Labyrinth
- Iron Key Subterranean Volcanic River
- Keys to Royal Chamber Dungeon Passageway/Bell Room
- Lavender Rose Forest Altar
- Magic Scroll Darm
- Magic Water Enchanted Fountain
- Marble Merith
- Moonstone Ancient Well
- Note Brandon's Home
- Orchids Tropical Lagoon
- Pine Cone Random Location in Forest
- Potions Zanthia's Laboratory
- Quill (feather) Cardinal
- Rocks Labyrinth
- Royal Chalice Little Forest Creature
- Royal Crown Evil Fireplace
- Royal Scepter Kitchen
- Ruby Tree
- Saw Brandon's Home
- Silver Rose Brynn (Temple)
- Sunstone Bubbling Spring
- Teardrop Two screens east of Weeping Willow
- Tulip Bubbling Spring
- Walnut Random Location in Forest

MAPS

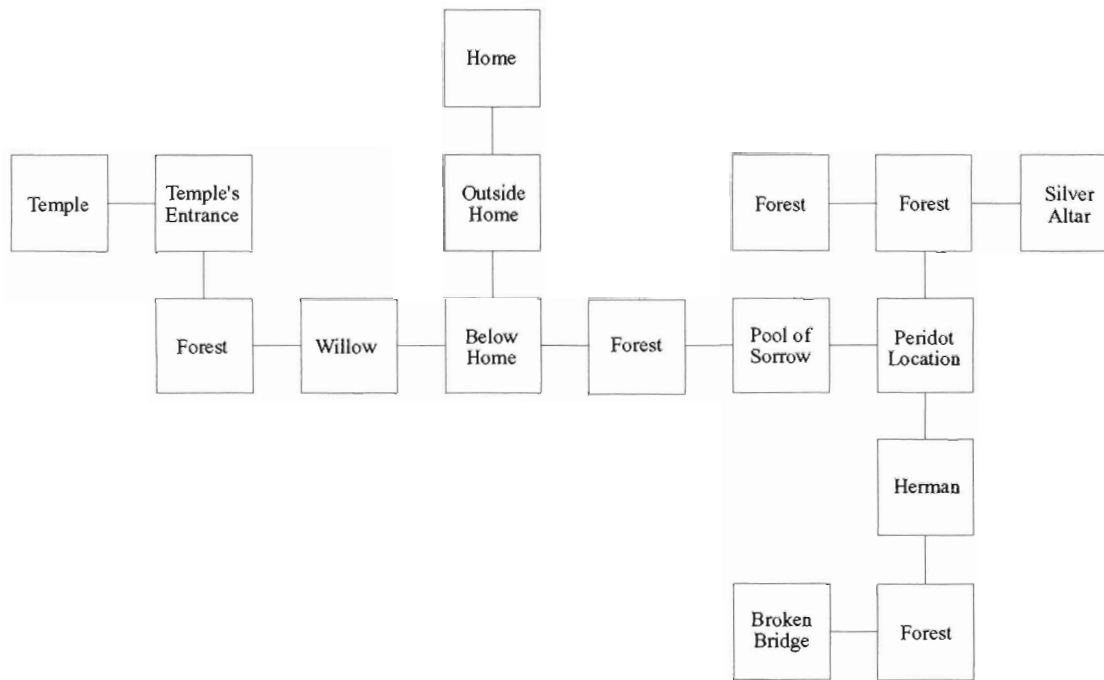

CHAPTER ONE

CHAPTER TWO (TIMBERMIST)

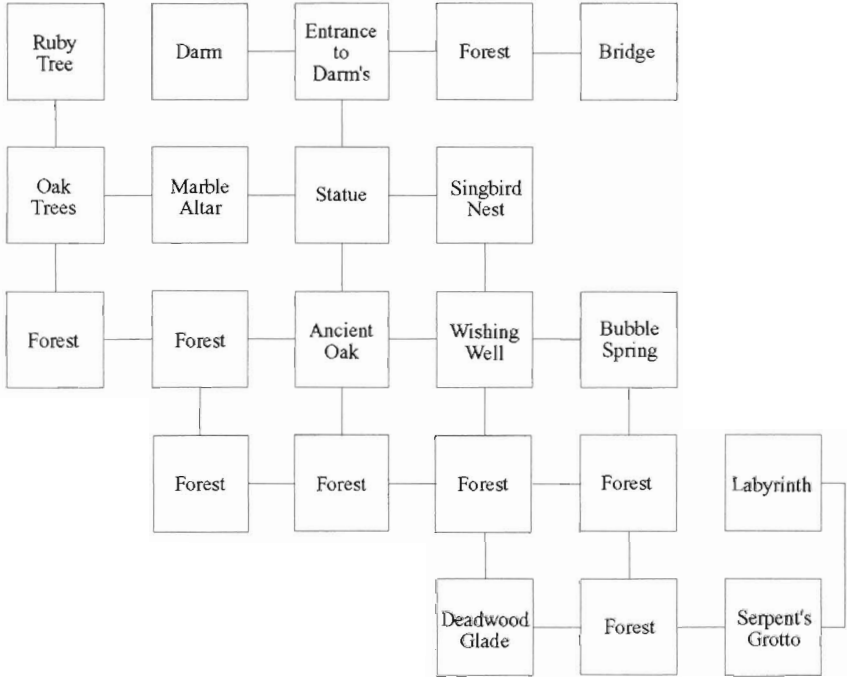

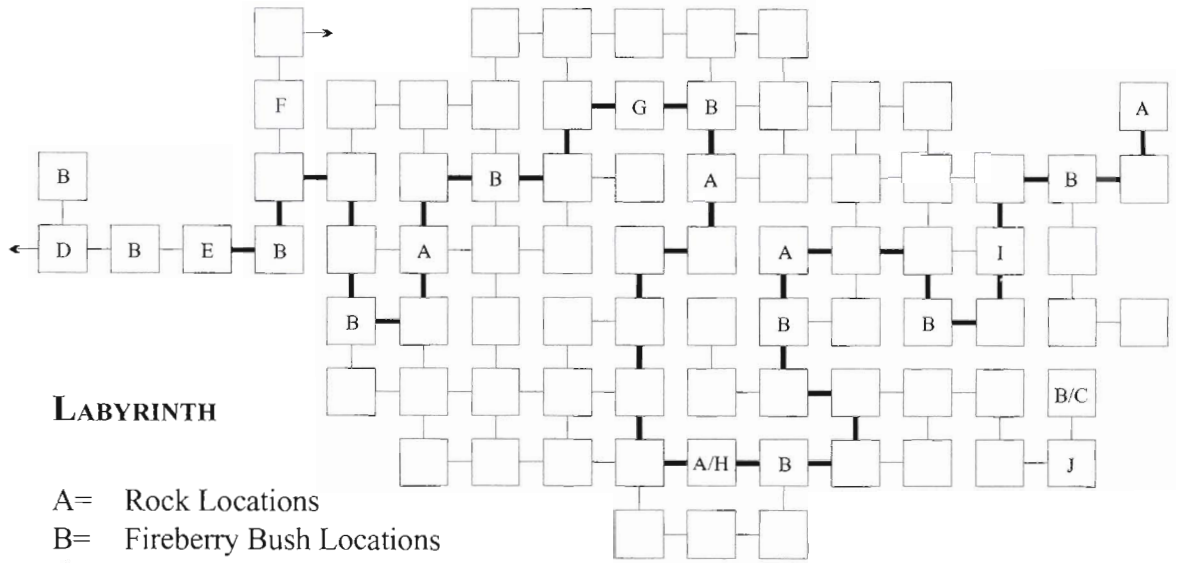

LABYRINTH

- A= Rock Locations
- B= Fireberry Bush Locations
- C= Key
- D= Mineral Pool
- E= Iron Gate
- F= Chasm of Everfall
- G= Pantheon of Moonlight
- H= Cavern of Twilight
- I= Emerald Cave
- J= Volcanic River

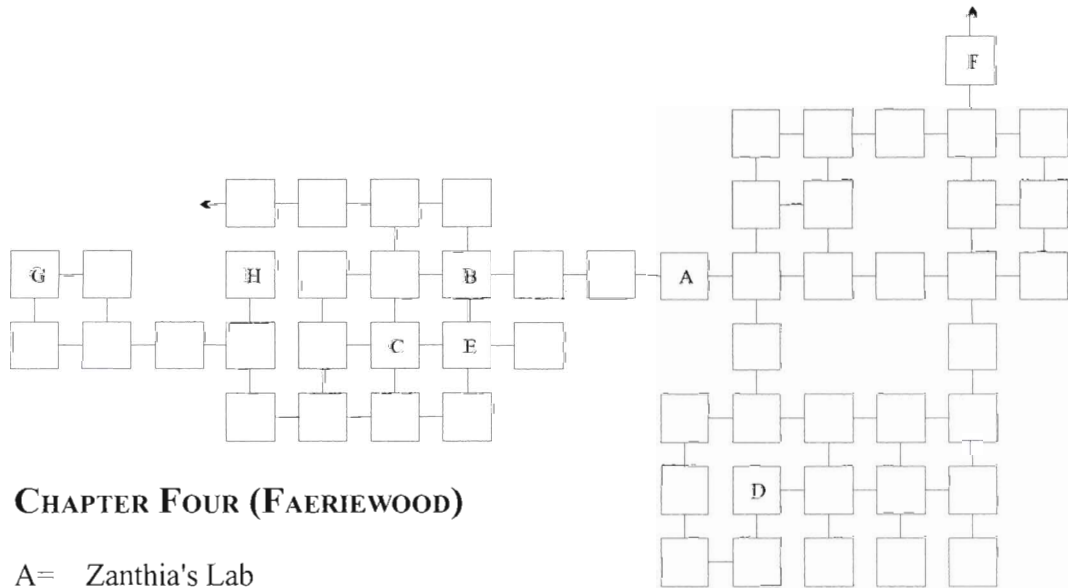

CHAPTER FOUR (FAERIEWOOD)

- A= Zanthia's Lab
- B= Magic Fountain
- C= Chalice
- D= Crystals
- E= Faun's House
- F= Lagoon
- G= Waterfall
- H= Flaming Tree

CASTLE (MAIN LEVEL)

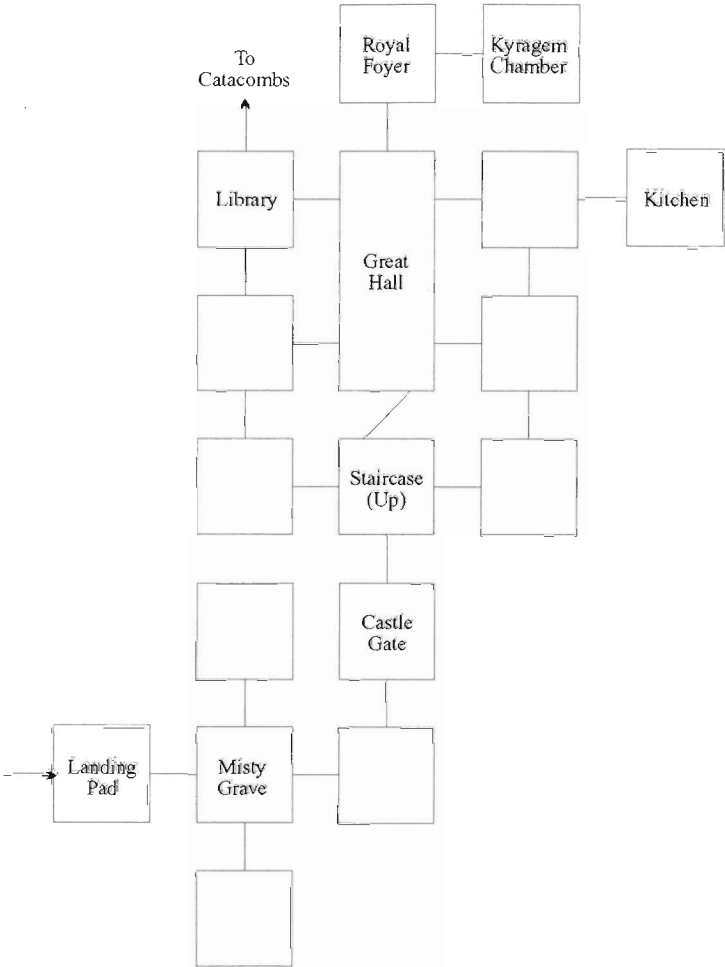

CASTLE (UPPER LEVEL)

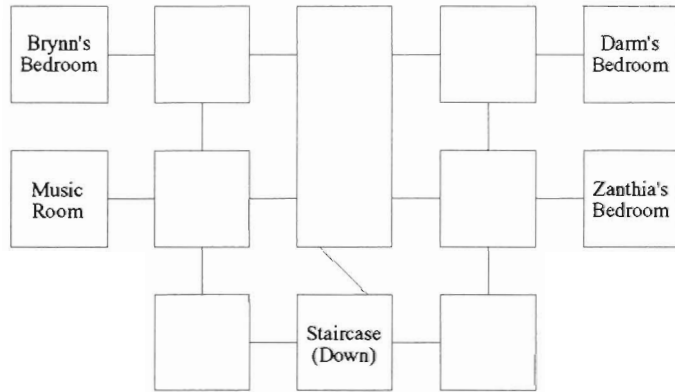

CATACOMBS

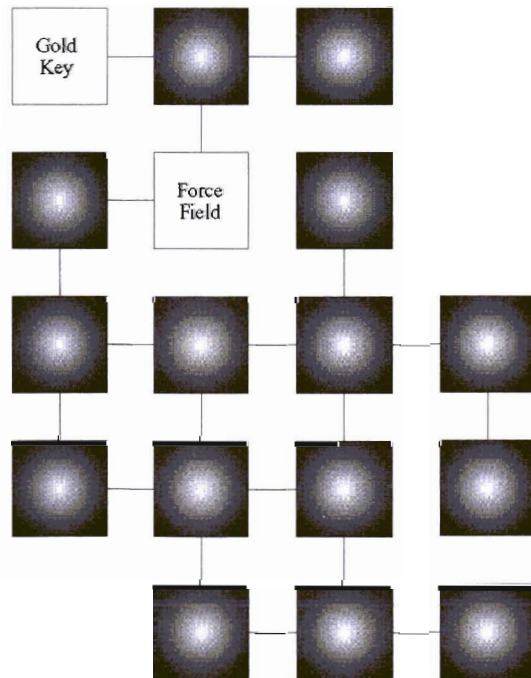

CHAPTER 20

MONKEY ISLAND 2

GRAPHICS:	☆☆☆	STORY LINE:	☆
ARCADE:	☆	INTERFACE:	☆☆☆
DIALOGUE:	☆☆	AUDIO:	☆☆
ANIMATION:	☆☆	LENGTH:	☆☆☆
OVERALL ANALYSIS: ☆☆☆			

SYSTEMS

- MS-DOS IBM-PC/Tandy & Compatibles
- Amiga
- Macintosh

FEATURES

- 256-color scanned art. More than 6.4 million pixels!*
- Ja, interactive reggae music, mon!*
- Laugh so hard milk will come out of your nose.*
- Optional easy mode for beginners and magazine reviewers.*
- Void where prohibited.*

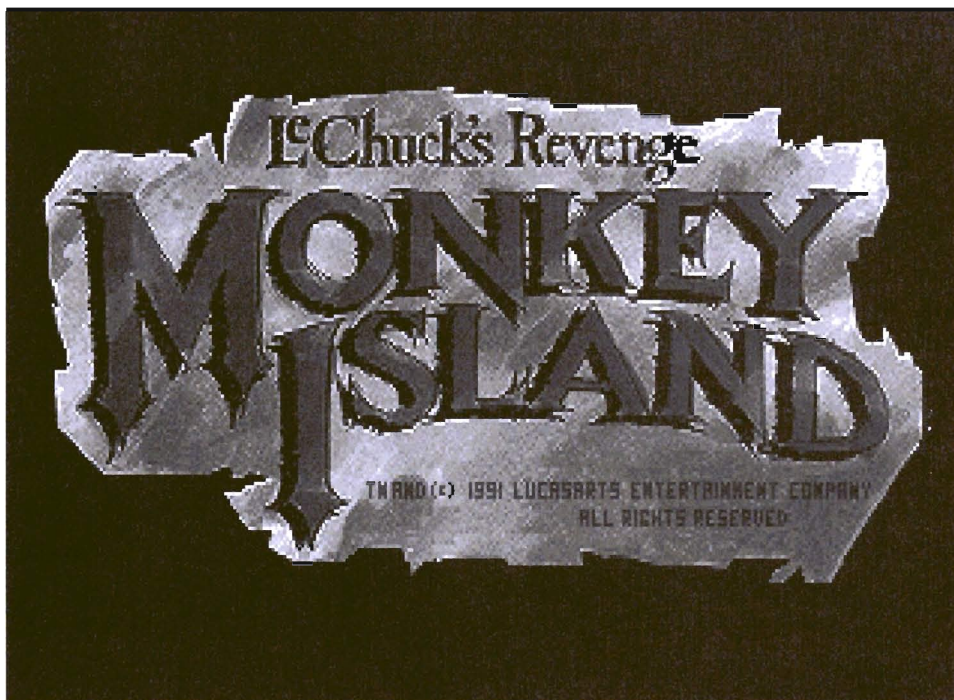

SCENARIO

Ahoy, matey. Climb aboard me vessel so we may set sail to the cay known as Monkey Island. Aye, passage will be but a gold nugget or a jug of spiced rum. So hurry now, my humble deckhand—I mean friend—we must shove off and seek the Ghost Pirate LeChuck and filch the magic treasure of Big Whoop. Designed by Ron Gilbert of LucasFilm Games, *Monkey Island 2: LeChuck's Revenge* is a fatuous sequel in which you assume the role of Guybrush Threepwood. As Guybrush, you'll be digging up abject graves embodied by pirates of yesteryear, testing your propelling skills in a spitting contest, and hightailing it from isle to isle in search of the magic treasure. The scenes are nicely done but somehow lack the visual splendor found in a Sierra, Virgin, or Origin game. The interface is similar to that used in *Indiana Jones: The* commands are listed in the lower-left corner of the screen and inventory is positioned opposite the commands. Because of the interface, full-screen graphics don't exist in this adventure. Since no one dies in *Monkey Island 2*, the need to constantly save the game is eliminated.

WALK-THROUGH

PART I: THE LARGO EMBARGO

Begin the adventure by finding the items necessary to create a voodoo doll of LaGrande. The ingredients you must find follow:

- Toupee
- Human bone
- Spit
- Pearly white bra



Before entering the town of Woodtick, take the shovel from the sign. Cross the bridge by walking west and say hello to Largo LaGrande. Use the following responses with LaGrande:

- 1-2

Walk west and enter the second doorway (Cartographer). Walk to the pile of papers located in the southeast corner of the room. Take the paper. Talk to the cartographer using the following responses:

- 2-2-1-1-3-1-1-2-3-2-2-1-1-1-1-3 (whew)

Wait patiently for Wally B. Feed to remove his monocle. Take the monocle from the desk. Approach the southernmost ship and enter the tavern (via the hatch). Talk to the bartender using response No. 1. When Largo appears and vulgarly spits on the wall, use the paper to collect the slimy green spittle. Enter the tavern's kitchen by climbing through the open window. Get the knife from the table, then exit the kitchen. Walk west to reach the hotel's lobby. Use the knife to cut the alligator's leash (rope). After the innkeeper leaves, look at the bowl on the floor. Get the cheese squiggles from the bowl. Look at the guest book. Walk up the



staircase and enter the hotel room (west door). Get the toupee from the dresser. Leave town by walking east. Travel to the cemetery. Walk to the graves located on the crest of the hill. Using the shovel, dig up the grave marked

□ Marco Largo LaGrande

Get the human bone. Leave the cemetery and head toward the beach. Get the stick, then travel to Woodtick. Go to the laundry ship and look at the bucket below the Men of Low Moral Fiber (pirates). Attempt to pick it up, then use response No. 1. Leave town and travel to the swamp. Fill the bucket with mud and travel back to town. Enter the hotel room and close the door. Place the bucket of mud on the door and hide behind the dressing screen. After the bucket falls on Largo, follow him to the laundry ship. Go back to the hotel room and close the door. On the back of the door you'll find a laundry claim ticket. Get the ticket and give it to the pirate at the laundry ship. Get the pearly white bra, then leave town. Travel to the swamp. Climb into the coffin and row two screens east, then row toward the shack. Once inside the fortune-teller's hut, get the string from the table. Walk east and talk to the fortune teller using the following responses:

□ 1-1-1-1

Give her the toupee, the spittle, the human bone, and the pearly white bra. When you have the voodoo doll in your possession, use the coffin to cross the swamp. Walk to town and enter the hotel room. After being kicked out by Largo, reenter the room and use the needles on the voodoo doll. Go back to the laundry ship and open the box below the Men of Low Moral Fiber. Use the stick on the box. Use the string on the stick. Place the cheese squiggles into the box. When the rat goes for the cheese, pull the rope to capture him. Open the box and retrieve the trapped rat. Enter the tavern's kitchen (via the open window) and place the rat into the

MONKEY ISLAND 2

pot of vichyssoise. Enter the tavern and ask the barkeeper about the stew. When offered a job, ask how much it pays. Take the job, then exit the kitchen through the window. Venture to the southern peninsula. Walk to the houseboat. Give the monocle to Captain Dread and charter the boat.

PART II: FOUR MAP PIECES

While aboard the *Jolly Rasto*, grab the parrot chow. Enter the cabin and use response No. 1 with the Captain. Tell him you want to travel to Phatt Island. When the Goon asks if you're Threepwood, use the following responses:



3-2-2

When you meet the Governor, use the following responses:

3-2-5-1-1-1-2-3-4

From within the jail cell, pull the mattress and get the stick. Use the stick on the leg bone of the skeleton. Take the bone and give it to the dog. Pick up the small key and use it on the cell door. Walk to the desk. Get the manila—and the *gorilla*—envelope. Examine the envelopes. Walk to the door and look at the posters. Walk to the east alleyway (next to the library). After the townsman wins some cash, follow him into the next alley. Right-click on the green door. Ask for the next winning number. To pass his hand test, use the trial-and-error method. If his hand code seems impossible to pass, try the following responses:

3-1-2-1

Write down the winning number. Walk to the wharf, then enter the first alley.

Talk to the dealer using the following responses:

2-1

Use the winning number to get an invitation to Governor Marley's Mardi Gras Party. Leave the alley and walk to the pier. Talk to the fisherman using the following responses:

1-1-3-4-1-1-3-5-1

You won't be able to catch a fish here, so enter the library. Look at the card catalog (you'll need to use it later in the game). Leave Phatt Island and tell the Captain that you want to travel to Booty Island. Talk to the old man. Enter the Costume Shop. Talk to the shopkeeper using the following responses:

1-2-1-1-1-3

Give the invitation to the shopkeeper and he'll give you a costume. Leave the Costume Shop and talk to the lady wearing the large hat (Captain Kate Capsize). Use the following responses with Kate:

1-1-4

Leave town and travel to the guard house on the bridge crossing. Give the guard the invitation. Walk along the path and cross the stream via the fallen tree. Open the door and enter the mansion. Get the map from above the fireplace (west wall). Look at the map. Exit the mansion and talk to Elaine using the following responses:

1-3-2-2-3

Go upstairs and get the oar from above the bed. Exit the mansion. Use the knife on the map piece. Exit the mansion again and walk to the side of the edifice. Push the garbage can. When the chef yells at you, walk around the mansion and pick up the dog. Go back and push the trash can. This time the chef will chase you

MONKEY ISLAND 2

completely around the mansion. Quickly enter the kitchen and take the fish. Travel to Phatt Island and give the fish to the fisherman. In return, he'll give you his fishing pole. Journey to Booty Island and walk to the cliff (where the map piece landed). Click on the south portion of the screen. Do you see what I see? It's the map piece! Attempt to retrieve it using the fishing pole and a pesky bird will grab the map from the hook.

Follow the bird to the big tree. Place the oar into the hole next to the plank. Step on the plank, then on the oar. After the oar breaks, get the broken oar and take it to the woodsmith (Scabb Island). Give the oar to the woodsmith and he'll fix it for you. Go back to the big tree and use the reinforced oar in the hole next to the plank. Climb on the plank, then on the oar. Get the plank and place it into the next hole. Repeat this procedure with the oar. Continue this feat until you reach the top of the tree. Enter the lookout tower and take the telescope. Enter the tree house and use the dog on the pile of papers. Get the map piece. Leave the tree house and walk down the path. Finally, travel to Ville de la Booty.

SECOND MAP PIECE

Locate the antique dealer (his shop is north of the cannon). Pick up the well-polished old saw. Travel to Scabb Island and saw off the peg leg of the Man with Low Moral Fiber (laundry ship). Visit the woodsmith and read the sign in his shop. Get the hammer and some nails. Now it's time to get the key that unlocks the crypt. Travel to Booty Island and visit Stan's Previously Owned Coffins. Talk to Stan using the following responses:

❑ 1-1

When Stan sits in the Cadillac Coffin, attempt to nail it shut (using the hammer and nails). Ask for another demonstration, then nail the lid shut. Get the golden key hanging on the far wall. Use the bell. Exit the store. Before you can use the crypt key, you must find the name of the correct coffin. Begin by traveling to the Governor's Mansion on the island of Phatt. Open the gate and approach the mansion. Open the front door and enter the foyer. Use the following responses with the guard:

❑ 2-2

After the guard leaves, go upstairs and locate the book entitled *Famous Pirate Quotations* (it's on the bed). If you haven't already read the book the fortune teller gave you, read it now. Then use that book on the book of quotations. Look at the book. Remember Rapp Scallion's quote:

- Violets are blue, roses are red ...
We're coming aboard. Prepare to eat lead.*

Travel to Scabb Island and enter the cemetery. Use the crypt key to unlock the crypt. Enter the crypt and look for the coffin containing Scallion's quote. Open the coffin and pick up the ashes. Travel to the swamp and use the coffin to reach the fortune teller. Pick up the jar labeled:

- Ash-2-Life*

Use response No. 1 with the fortune teller. Travel to Phatt Island and enter the library. Talk to the librarian using the following responses:

- 1-1-2-1-4-3-2-1-1

Walk to the card catalog and open the drawer labeled:

- PQR*

Locate the index card labeled *Recipes* and find the book entitled *The Joy of Hex*. Use the following responses:

- 3-1

Talk to the librarian using the following responses:

- 1-1-1

Exit the library and travel to Scabb Island. Approach the fortune teller and use response No. 1. After she gives you the potion, travel to the cemetery and enter

MONKEY ISLAND 2

the crypt. Look at Rapp's coffin. Use the bottle of *Ash-2-Life* on the ashes. Use the following responses with Rapp:

❑ 1-1-5-4-2

To turn off the gas, travel to the beach. Walk to the shack and open the door. Enter the shack. Use the knobs. Exit the shack and return to the crypt. Look at Rapp's coffin. Use the potion and response No. 2. He'll give you the second map piece.

THIRD MAP PIECE

Leave the crypt and travel to the town of Woodtick. Enter the tavern through the hatch. Talk to the barkeeper using the following responses:

❑ 1-1-1-1-1-2-1-3-2

After you have all three drinks, mix the yellow drink with the blue drink. This will give you a green drink that will aid in the spitting contest. But before you go a-spittin', enter the antique store and purchase the ship's horn. Use the horn. Exit the shop and use the horn near the cannon. Enter the spitting contest by talking to the Spitmaster. After losing the contest, blow the ship's horn. When the Spitmaster leaves the scene, quickly pick up (and move) the marker flags. Use the straw on the green drink. Reenter the contest. Wait for the wind to blow the woman's red scarf, then spit. Congratulations—you've just won a spit plaque.

Give the spit plaque to the antique dealer and use the first response throughout the entire conversation. Look at the third map piece on the counter (the antique dealer will give you the map piece if you bring him the figurehead from the sunken ship *Mad Monkey*). To find the coordinates of the *Mad Monkey*, travel to the library on Phatt Island. Use the card catalog to look up *Shipwrecks*, then *Disasters*. Get the book entitled *Great Shipwrecks of Our Century* from the librarian. Use the following responses with the librarian:

❑ 1-1-1

Look at the book and note the coordinates of the *Mad Monkey*:

❑ 34N 89W

Walk to Dread's ship and travel to Booty Island. Talk to Captain Kate using the following responses:

❑ 2-2-1

After chartering the glass-bottom boat, move the cursor until you plot the correct coordinates. Upon your arrival, plug your nose and dive into the ocean. Retrieve the figurehead and pick up the anchor. Give the monkey head to the antique dealer and he'll give you the third map piece. Only one more to go ...

FOURTH MAP PIECE

While at the antique dealer, try to pick up the mirror the parrot's gazing into. Purchase the Beware of Parrot sign. Place the parrot-chow bag on the hook. Now you can purchase the mirror.

To open the waterfall's secret passageway, you'll need a monkey. Remember the monkey playing the piano at the tavern? Travel to Scabb Island and enter the tavern via the hatch. Attempt to pick up the monkey. If that doesn't work, place the banana on the metronome. Pick up the monkey, JoJo, and exit the tavern. Travel to Phatt Island. Place the leaflet (which you received from Captain Kate) over Guybrush's wanted poster. Walk to Dread's ship. After Kate gets arrested, enter the jail and take the *vanilla* envelope from the first shelf. Open the envelope and you'll find a bottle of nonalcoholic near-grog. Leave the jail and walk to the path. Go to the waterfall and follow the east path. Walk to the pump. Use JoJo (the monkey) on the pump. Walk back to the waterfall and you'll find a secret passageway. After entering the passage, walk three screens west. Walk to the cottage. Before entering the cottage, open the shutters of the left window. Enter the cottage and use the following dialogue responses with the pirate:

❑ 5-4

After the pirate gives you a mug of grog, place the mirror into the empty mirror frame. Use the stool. After getting drunk, reenter the cottage. After the pirate

MONKEY ISLAND 2

gives you another mug of grog, use the mug on the tree located at the left side of the room. Quickly fill your mug with near-grog. After the pirate passes-out, exit the cottage. Place the telescope in the hands of the grotesque statue. Follow the beam of light. Push the brick that's in the path of the beam of light. Just watch out for the butt slide ...

What's that in the skeleton's hand? Why, it's the fourth map piece! Get the map piece and look at it. Exit through the hole in the west wall. Travel to the wharf and enter the library. Walk to the west side of the room and open the model lighthouse. Pick up the model lighthouse lens. Exit the library. Now give the four map pieces and the lens to the cartographer on Scabb Island. He'll ask you to retrieve his love potions from the International House of Mojo (the fortune teller). Do as he asks. On your return, you'll notice that the cartographer is missing. Note the writing on the table. Travel to the swamp and open the crate. Use the crate.

PART III: LECHUCK'S FORTRESS

After a lengthy crate ride, you'll notice a juju bag in inventory. Open it and you'll find the following items:

- Matches
- Love bomb

Travel east until you reach a staircase. Walk up the staircase and look at the *sign-o-splinters*. Enter the back tunnel by walking east. To get through the labyrinth, use the spit-encrusted paper from inventory. Push, and enter, the following bone doorways:

- Hand/Rib/Hip
- Arm/Head/Rib
- Leg (*feet*) /Hip/Arm
- Head/Rib/Hip

Look at the huge door. Push the center of the door and walk through the doggy doorway. Attempt to pick up the voodoo key. After being captured and lectured

by LeChuck, use the straw on the red drink. Spit at the northeast shield. Eventually you'll extinguish the candle flame. To illuminate the dark room, light a match. Oh no, *dynamite!* I hope you didn't light a match ...

PART IV: DINKY ISLAND

Welcome to Dinky Island. Begin by gathering the following items:

- Bottle (beneath the Welcome sign)
- Crowbar (below still)
- Martini glass (below still)

Open the barrel and get the cracker. Give the cracker to Polly the parrot and he'll give you your first destination clue:

- From the pond, walk due east until you reach a green dinosaur.

Talk to Herman Toothrot using the following responses:

- 2-1-2-3

Walk west to reach the jungle entrance. Enter the jungle, then walk northeast. Get the rope from the box. Open the box with the crowbar. Pick up the dynamite. Walk southwest, then walk one screen west. Continue along the path until you see a bag hanging from a tree limb. Attempt to pick up the bag. Use the empty bottle on the tree. Use the broken bottle on the hanging bag. Get the fallen box. Look at the box of cracker mix. Travel back to the beach. Get some water using the Martini glass. Use seawater in the still. Use the cracker mix with the distilled water. Give the crackers to the parrot and he'll give you the directions to reach the big X:

- Walk north from the green dinosaur until you see a pile of rocks.
- From the rocks, walk east.

After finding the big X, use the shovel to dig a hole. Now use the matches on the

MONKEY ISLAND 2

dynamite. Place the lit dynamite into the hole. After the explosion, combine the rope with the crowbar. Use the crowbar/rope device on the twisted metal rods (above the treasure chest). The next scene will look painfully familiar to you. When you arrive in the dark room, move the cursor around the screen until you find the light switch. Use the switch. Use the following responses when conversing with LeChuck:

3-2-3-3-1-3

Find the room containing the Grog machine. Use the coin return. When LeChuck reaches for the coin, close your eyes and grab his underwear. Travel through the corridors until you find the first-aid station. Open the medical drawer and take the syringe. Get the skull on the right. And, finally, look inside the white trash can and get the *stuff* (surgical gloves). Walk to the storage room and open the boxes. Get the balloon and a voodoo doll. Find the elevator and push the call button. Enter the elevator. After being *voodoo'd*, reenter the elevator. When LeChuck appears, use the lever. Pick up the beard and open the door. Look at the poster, then close the door. Read the sign on the back of door. Enter the elevator and use the lever. Wait for LeChuck, then give him the white hanky. Now you must quickly construct a voodoo doll from the items in inventory. Do you remember how the fortune teller did it? Place the following items into the juju bag:

- Beard
- Skull
- Underwear
- Voodoo doll
- White hanky

When LeChuck attacks you, use the syringe on the voodoo doll. Follow LeChuck, then use the following responses to win the game:

2-3-4-2-2-1-1-3-4



LOCATION OF OBJECTS

- Ash-2-Life Fortune Teller
- Ashes Rapp's Coffin
- Balloon Storage Room
- Banana Jail Cell (Phatt Island)
- Beard LeChuck
- Bottle Dinky Island
- Bucket Laundry Ship
- Cheese Squiggles Alligator Bowl
- Costume Costume Shop
- Cracker Barrel (Dinky Island)
- Cracker Mix Dinky Island
- Crowbar Dinky Island
- Dog Kitchen Entrance
- Drinks Tavern
- Dynamite Box in Jungle (Dinky Island)
- Figurehead Ocean
- Fish Kitchen
- Fishing Pole Fisherman
- Generic Voodoo Doll Storage Room
- Golden Key Stan's Coffins
- Gorilla Folder Jail Cell
- Hammer Woodsmith
- Horn Antique Dealer
- Human Bone Marco Largo LaGrande Grave
- Invitation Dealer (Alley)
- Knife Kitchen
- Laundry Claim Ticket Hotel Room (On Door)
- Leaflet Captain Kate
- Manila Folder Jail Cell
- Map Piece No. 1 Fireplace
- Map Piece No. 2 Rapp
- Map Piece No. 3 Antique Dealer

MONKEY ISLAND 2

- Map Piece No. 4 Skeleton (Pirate's cottage)
- Martini Glass Dinky Island
- Mirror Antique Dealer
- Monkey Tavern
- Monocle Cartographer
- Nails Woodsmith
- Needles Fortune Teller
- Oar Above Bed
- Paper Cartographer
- Parrot Chow *Jolly Rasto*
- Parrot Sign Antique Dealer
- Pearly white Bra Laundry Ship
- Rat Laundry Ship
- Recipe Card Catalog (Library)
- Rope Box in Jungle (Dinky Island)
- Saw Antique Dealer
- Shovel Sign (Entrance to Woodtick)
- Skull First-aid Station
- Small Key Dog (Jail Cell)
- Spittle Tavern
- Spit Plaque Spitting Contest
- Stick Beach/Jail Cell
- String Fortune Teller
- Surgical Gloves First-aid Station
- Syringe First-aid Station
- Telescope Tree Fort
- Toupee Hotel Room
- Underwear LeChuck
- Vanilla Envelope Jail Cell
- Voodoo Doll Fortune Teller

MAPS

BOOTY ISLAND

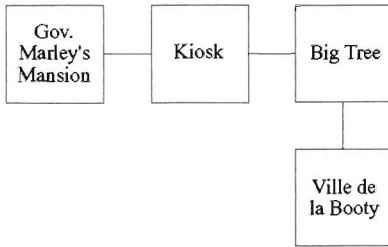

PHATT ISLAND

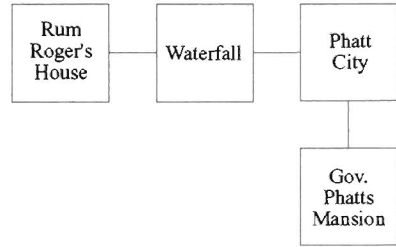

SCABB ISLAND

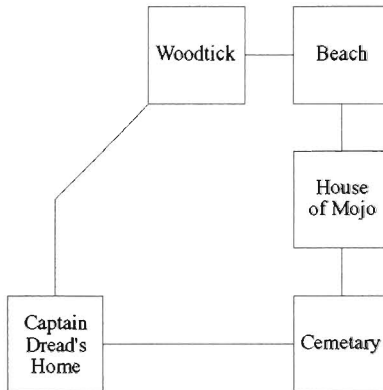

DINKY ISLAND UNDERGROUND

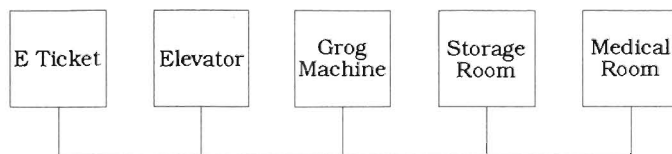

CHAPTER 21

ALONE IN THE DARK

GRAPHICS:	☆☆	STORY LINE:	☆☆
ARCADE:	☆☆☆	INTERFACE:	☆
DIALOGUE:	☆	AUDIO:	☆☆☆☆
ANIMATION:	☆☆☆☆	LENGTH:	☆☆☆
OVERALL ANALYSIS: ☆☆☆			

SYSTEMS

- MS-DOS IBM-PC/Tandy & Compatibles
- Macintosh
- Amiga (Winter 1993)

FEATURES

- Learning how to deal with the hideous, hidden monsters is all part of the frightful fun.*
- Designed with an action format, this is the first full-screen 3-D adventure game for the PC.*
- Depending on your location in the room, you'll view the action from up to nine different angles.*
- Down in the creepy catacombs, Derceto is dark and sinister. Unfortunately, this is where your quest must ultimately lead.*
- 3-D real-time animation.*
- Electrifying music and sound effects.*
- 256 vivid colors.*
- More than 50 hours of gameplay.*

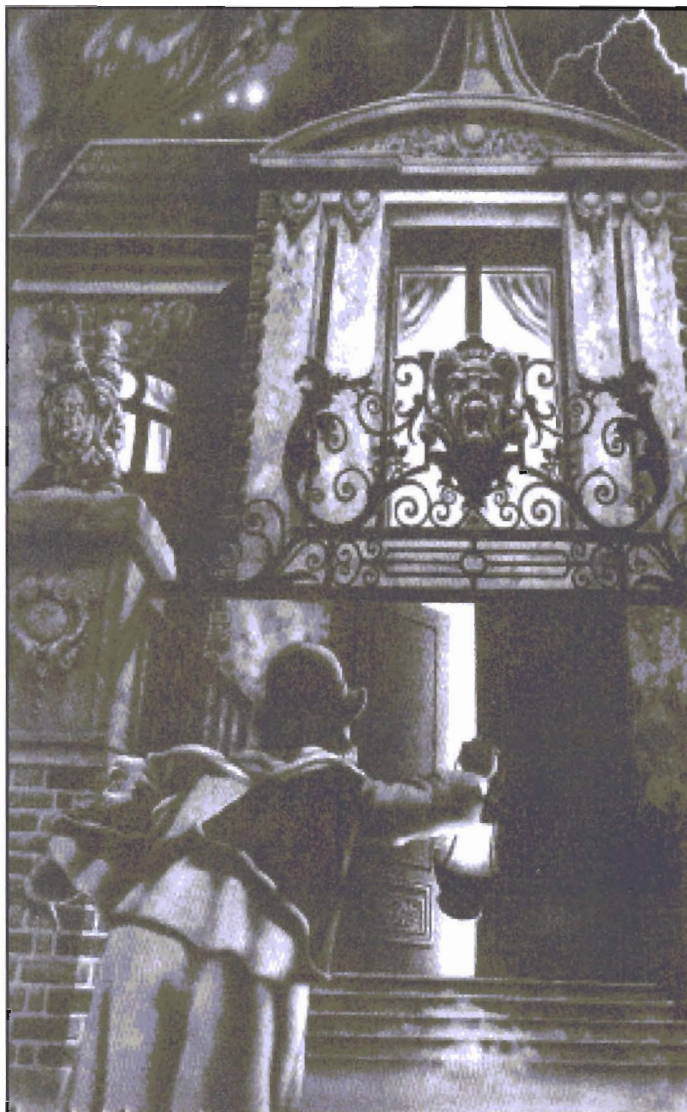

SCENARIO

Inspired by the work of H.P. Lovecraft and created by the French developers Infogrames and I.Motion (a new publishing partnership with Interplay), *Alone in the Dark* combines new technology with the animator's oldest friend; the polygon. The synergy of this system provides the viewer with superior animation—but there's a catch: The detail of the characters is slightly unrefined.

After maneuvering *blockhead* around the attic, however, I was immediately overwhelmed by his lifelike gesticulation:

The way he crouched before firing the shotgun, then forcefully pumped another load into the chamber; the way he fluidly opened doors, cabinets, and chests; and the smoothness of the combat sequences. As you rove from room to room, you'll see up to nine different camera views, making this virtual adventure very movie-like. Although *Alone in the Dark* has no mouse support, I found the keypad interface tolerable.

WALK-THROUGH

THE ATTIC

After choosing your character, the quest begins in the attic of the Derceto Mansion. Quickly obtain the following items:

- A lamp
- An Indian cover
- A rifle



The lamp rests on the table. The Indian cover is in the orange wardrobe. The rifle can be found in the chest. There's a book on the bookshelves and a note pinned to the piano, but these two items aren't necessary to complete the game. If a ghoul appears, defeat it using your fists (or feet, if you're Bruce Lee). Just save your ammo for later in the game. Leave the attic through the doorway near the barrels and the rocking horse.

Hint: Save the game after every successful move!

THE SECOND FLOOR

Since this game uses many different "camera angles," the N, S, E, W routine is history. I'll be referring to the maps at the end of this chapter to guide you through this game. In the storage room, take the bow and the oil can. *Reload* the lantern and *throw* the empty oil can. Open the door and save the game. DO NOT walk down the hallway, as the floor is weak and will collapse. Enter bedroom No. 1 and close the door behind you (this will keep out the ghoul). Take the chest's key from within the rolltop desk. Use the key on the chest and take the old cavalry saber. Open the door and *fight* the ghoul. Enter the sitting room of bedroom No. 2. Quickly close the door behind you. Walk into the adjoining room and take the

vase from the nightstand. Defeat the winged creature. Throw the vase and get the dresser's key. Unlock the dresser, using the key, and take both mirrors. Save the game, since these mirrors will crack if you get into another fight. Exit bedroom No. 2 and enter the bathroom. Take the first-aid kit and open it. Take the flask of healing potion and throw away the empty box.

***Hint:** The healing potion will restore some of your health points. But, if at all possible, try saving it for later.*

Open the door at the end of the hallway. To get past the winged creatures, place a mirror on each of the statues. I'll see you downstairs.

THE FIRST FLOOR: THE SUIT OF ARMOR

To get the sword from the suit of armor, you'll need to find a heavy statue you can hurl at it. The heavy statue is located in the dark bedroom on the first floor. You can wander aimlessly about the dark bedroom until you bump into the statue, or you can get the matchbook (from the drawers in the kitchen) to light the lantern. Once you've acquired the heavy statue, throw it at the suit of armor and retrieve the sword.

THE PURPLE BATHROOM MONSTER

You can't defeat the purple monster—but you do need to get the jug and the first-aid kit. Save the game before entering the bathroom. Quickly grab the jug from the floor, then search the closet. Take the first-aid kit and get the heck out of there.

THE MASTER GALLERY

To get through the Master Gallery, you'll need the bow (found in the storage area on the second floor), the Indian cover (found in the attic), and the arrows (found below the statue in the Atrium). Drape the Indian cover over the painting with the man holding a hatchet. Walk down the hallway until the painting on the far wall can be seen. Nock an arrow, take aim, and launch it at the painting.

THE LIBRARY

Have you found the fake book in Jeremy's study? If so, save the game, then use the lantern. Enter the library and place the lantern on the floor. Run to your character's left (avoiding the purple monster). When you reach an indentation in the bookcase, search the area and you'll find a trigger. Place the fake book in the trigger and the secret panel will open. Enter the secret room and take the talisman and the first dagger (curved blade). Use this dagger to kill the purple monster.

THE SITTING ROOM

Did you notice the apparition sitting in the chair? Don't get too close to it or you'll perish. The only item you require from this room is the gramophone.

THE GROUND FLOOR: THE KITCHEN

In the kitchen you'll find many useful items: a key that opens the cellar door, a biscuit box with healing qualities, a loaded revolver (in the shoe box beneath the coal pile), a matchbook, water to fill the jug, a pot of soup, and an oil can.

THE CELLAR

The cellar's key is located in the kitchen's storage room. After entering the cellar, get the bullets from the table while avoiding the deadly rats.

THE DINING HALL

To keep from getting killed by the ghouls, you must feed them. In the kitchen you'll find a pot of soup. Place the soup on the dining room table and wait for all the ghouls to be seated. Now you can safely enter and exit this room at leisure.

THE SMOKE ROOM

Do you keep dying in the smoke room? If so, did you take the jug from the bathroom with the purple monster and fill it with water in the kitchen? If you have the jug of water, stand near the ashtray and use the jug on the ashtray. Take the lighter. To unlock the adjoining secret room, you need the key hidden behind the grandfather clock in Jeremy's study. Enter the secret room and take the record.

THE PIRATE

To defeat the pirate, you'll need the sword from the suit of armor. Save the game before attempting to slay him. The trick to killing the pirate is quite simple: Wield the sword (while inching forward) to get him cornered, then hack away. After defeating the pirate, take the key that unlocks the dance hall.

THE DANCE HALL

To solve the dance hall puzzle, you need the gramophone from the sitting room and the record from the secret room in the smoke room. Unlock the doors using the pirate's key. Use the record to make the apparitions dance. Walk to the fireplace (while avoiding the ghosts) and snatch the key from the mantle. Leave the dance hall as quickly as possible.



TO GET BELOW THE HOUSE

To get below the house, you must locate, and open, the trap door in the secret room in the smoke room (the same room where you found the record, *Dance of Death*). To open the trap door, use the old cavalry saber on the coat of arms. If the blade breaks, pick up the broken saber blade and place it in the trigger. Put the saber handle in the trigger. Save the game. I'll be waiting for you in the realm below the Derceto Mansion.

THE UNDERWORLD

Save, save, save! Now, if you have the following items, you may proceed into the underworld:

ALONE IN THE DARK

- Treasure chest key (dance hall)
- Bullets (cellar)
- Full oil lamp (attic)
- Talisman (secret room in library)
- Lighter (smoke room)
- Revolver (kitchen, beneath coal pile)
- Flask (first-aid kit)
- Rifle (not required but recommended)

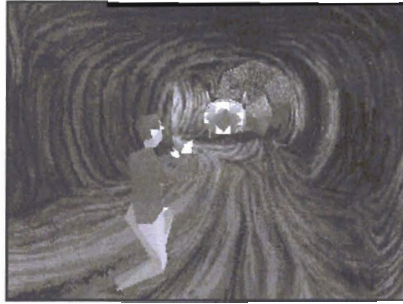

THE FALLING BRIDGE

To get across the falling bridge, you must run. Don't tell me you weren't aware of the fact that your character can run! To make him or her run, double-click the up-arrow key.

THE GIANT WORM

Follow the passageway until you encounter a giant worm—then run for your life! When you encounter a pesky cave dweller, shoot it with the rifle (or revolver) and continue your hasty escape from the giant worm. When you're face-to-face with *whale-bait*, stop dead in your tracks, turn, and retrace your steps. When you reach the end of the tunnel, turn right (if you see a fork in the tunnel, go west) and you'll reach a pool of water. Jump onto the jutting platform and follow it around the embankment until you reach the bridge. Jump over the bridge, then jump to the upper ledge. Kill the giant spider using either weapon.

THE STONE PLATFORMS

Save the game, then shoot the bird. Leap from pillar to pillar while saving the game after each successful jump. Continue along the path and you'll reach the bridge maze (avoid traveling south, since a giant spider inhabits the southern section of the underworld).

THE BRIDGE MAZE

To reach the pirate's treasure chest, approach the right platform and use the trial-and-error method to reach the other side (don't worry, it's not that tough). You may shoot the bird or avoid it as you weave across the maze. Use the key (which

you found in the dance hall) to open the treasure chest. Take the gem, then push the boulder behind the chest. Follow the tunnel until you reach the labyrinth.

THE LABYRINTH

Save the game, then use the lantern. If you took a plunge earlier in the game, the lantern will be wet and you'll need to use the lighter to ignite it. To get through the labyrinth, walk one screen west, then continue west until you can go no further. Travel one screen south, then southeast until you reach a new screen. Then walk to the southeast portion of the labyrinth and you'll find a stone door. Place the gem into the door to open it.

THE TREE ALTAR

Save the game, then wade through the water (avoiding the swamp thing and the fireballs) toward the large tree altar. When you reach it, take the hook and quickly place the talisman onto the altar. Throw the *lit* lantern at the tree. Now run for your life! Use the hook to open the door along the west wall of the altar room. To reach the front door of the house, find the secret passageway leading to the cellar, or simply retrace your steps until you reach the front door. Exit the house and enjoy the final animated sequence.



LOCATION OF OBJECTS

- Arrows Statue (Atrium)
- Biscuit Box Kitchen
- Bow Storage Room (2nd Floor)
- Bullets Cellar
- Dagger Secret Library Room
- Fake Book Jeremy's Study
- First-aid Kits Bathrooms
- Flasks First-aid Kits
- Gem Treasure Chest
- Gramophone Sitting Room
- Heavy Statue Dark Bedroom
- Hook Tree Altar
- Indian Cover Attic
- Jug Bathroom (1st Floor)
- Key to Cellar Kitchen
- Key to Chest in Bedroom No. 1 Roll-top Desk (Bedroom No. 1)
- Key to Dance Hall Pirate
- Key to Dresser in Bedroom No. 2 Vase (Bedroom No. 2)
- Key to Secret Smoke Room Behind Clock (Study)
- Key to Treasure Chest Dance Hall
- Lamp Attic
- Lighter Smoke Room
- Matchbook Kitchen
- Mirrors Dresser (Bedroom No. 2)
- Oil Cans Storage Room (2nd Floor)/Kitchen
- Old Cavalry Saber Chest (Bedroom No. 1)
- Pot of Soup Kitchen
- Revolver Kitchen (Under Coal)
- Record Secret Room (Study)
- Rifle Attic
- Sword Suit of Armor
- Talisman Secret Room (Library)
- Vase Nightstand (Bedroom No. 2)
- Water Kitchen

MAPS

SECOND FLOOR

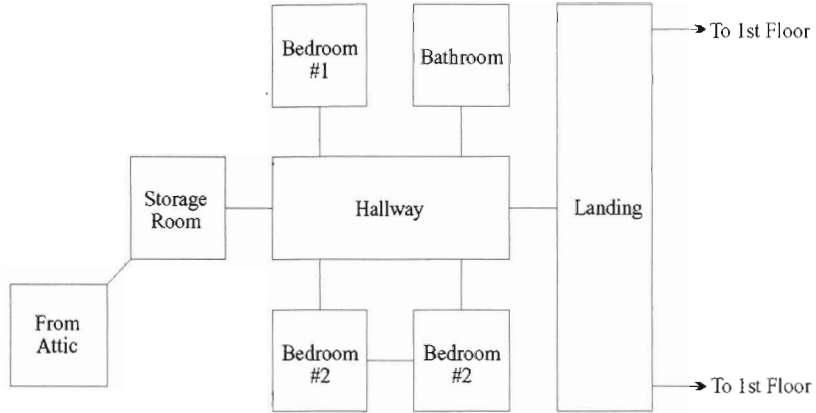

FIRST FLOOR

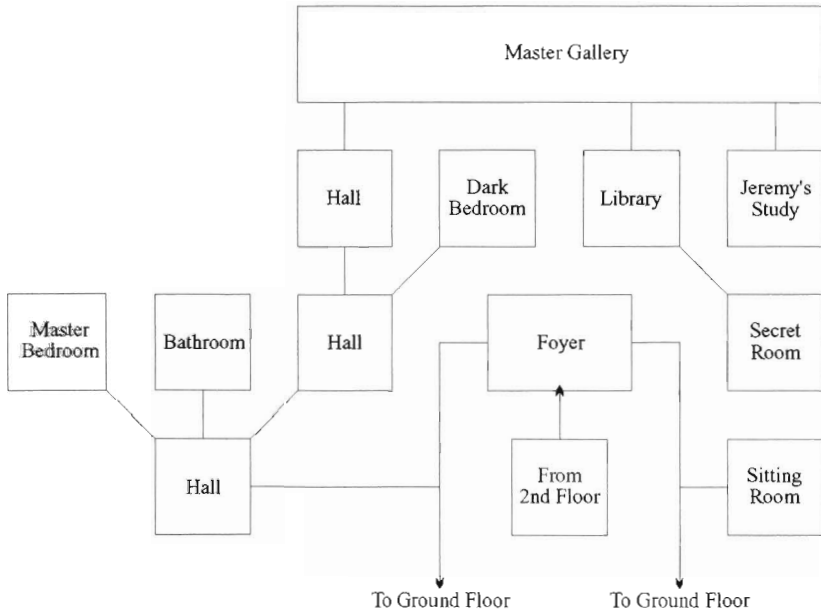

GROUND FLOOR

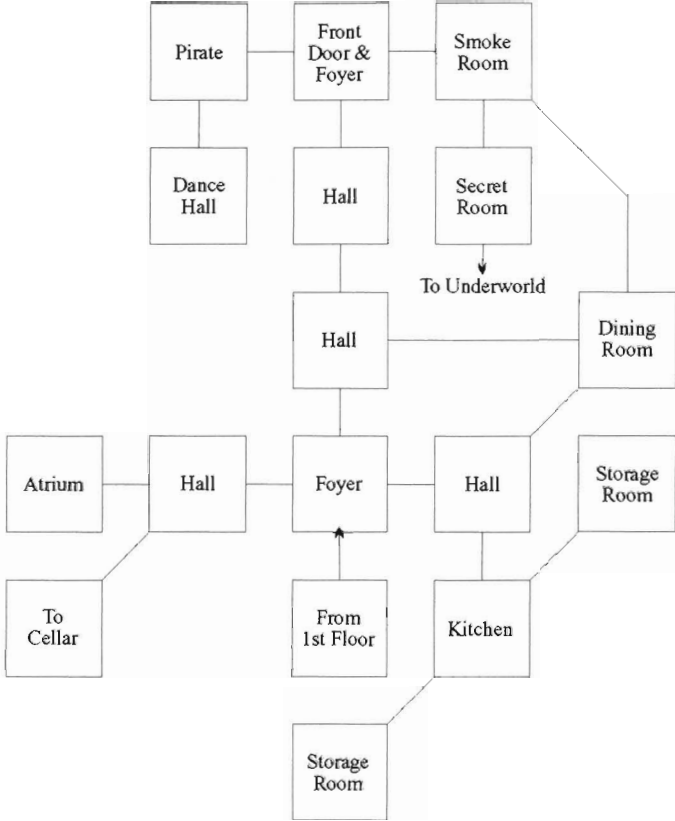

CHAPTER 22

THE LOST FILES OF SHERLOCK HOLMES

GRAPHICS:	☆☆☆☆	STORY LINE:	☆☆☆☆
ARCADE:	N/A	INTERFACE:	☆☆☆
DIALOGUE:	☆☆☆	AUDIO:	☆☆☆
ANIMATION:	☆☆☆☆	LENGTH:	☆☆☆☆
OVERALL ANALYSIS: ☆☆☆☆			

SYSTEMS

- MS-DOS IBM-PC/Tandy & Compatibles

FEATURES

- Explore dozens of authentic Victorian-era London locations, from Scotland Yard to Covent Garden.
- Interact with dozens of unique characters, each with their own personalities, characteristics, and alibis.
- Use the detailed overhead map of 1888 London to identify your next sleuthing destination.
- Refer to Dr. Watson's journal for a detailed record of your investigation.
- Call on your trusty band of Baker Street irregulars.
- Use your laboratory at 221B Baker Street to analyze clues.
- Intuitive point-and-click interface.
- Beautifully rendered 256-color VGA graphics.
- Classically scored soundtrack with more than 30 original themes.
- Digitized voice & sound effects (soundboard required).
- Deep and complex, providing many hours of challenging fun.

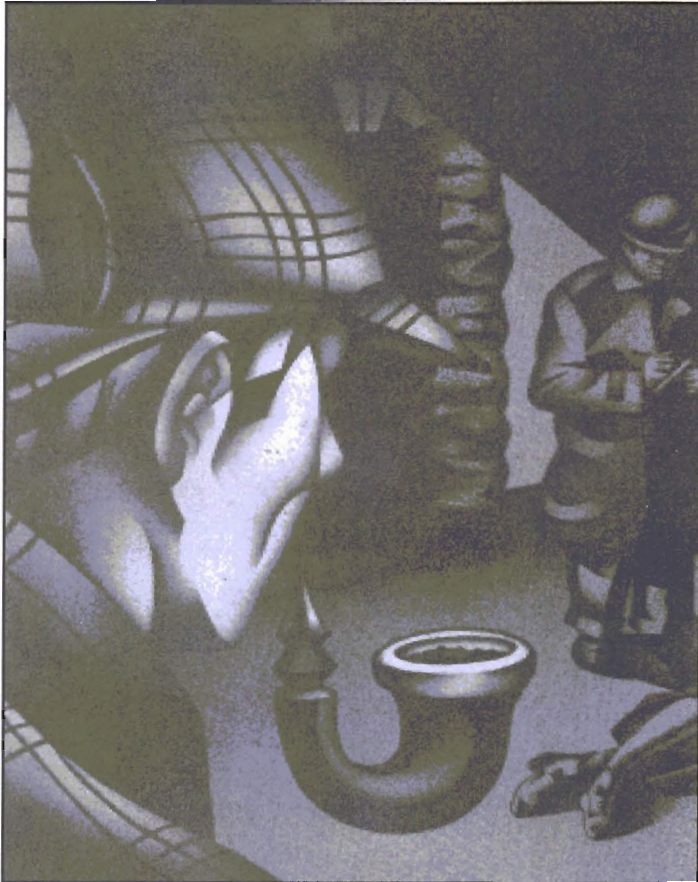

SCENARIO

An aspiring young actress has been viciously murdered behind the Regency Theatre. It appears to be the baneful doings of none other than Jack the Ripper. Inspector Lestrade brooded over the situation, then dutifully sought the help of London's best detective, Sherlock Holmes. From the combined effort of Mythos Software and Electronic Arts comes this graphical masterpiece,

which instantly propels your imagination into another era. And, with the use of a unique color palette, you actually feel as if you were in 19th-century London. From the opening scene (Cloudburst in London) to the stunning finale, the grandeur of mass animation saturates this adventure: The characters move constantly; every candle flame flickers, casting eerie shadows; and each raindrop that falls ripples a puddle. Such lavish animation demands a fast machine. Be sure you have a 386 or faster processor before purchasing this intriguing murder mystery.



WALK-THROUGH

PART ONE

Begin this mystery by checking inventory. Read the message from G. Lestrade and examine the business cards. Exit the inventory menu and talk to Dr. Watson using response No. 2. Read Watson's journal, then familiarize yourself with this room. Look at the bullet holes, the violin, the sheet music, Watson's desk, the lab table, and the Gasogene.



Now you can travel to the murder scene by first clicking the hand cursor on the door, then walking one screen east. When the map screen appears, click the hand cursor on the purple face (alley) and you'll automatically travel to the murder scene.

THE MURDER SCENE

Look at the corpse. Find, and look at, the abrasions, scratches, knife wounds, and white powdery residue. Take the white powdery residue and examine it using the inventory icon. Talk to Dr. Watson using response No. 1. Pick up the cigarette butts, the iron bar, and the battered piece of paper (playbill). Use the inventory icon to examine these items.



Talk to Inspector Lestrade using the following dialogue responses:

- 1-1-3

THE LOST FILES OF SHERLOCK HOLMES

Talk to the constable using response No. 2. Look at the hat (east side of screen), then talk to the Inspector using the following responses:

❑ 2-1

THE THEATER

Enter the theater via the backstage door. Walk to the east side of the room and examine the flowers. Take a flower and the handwritten card. Talk to Henry Carruthers using the following responses:

❑ 1-3-1-1-1-1

Have you noticed the sparkling gold spring beneath the wardrobe? Give this spring to Carruthers. Talk to Sheila Parker, then talk to Dr. Watson using response No. 4. After Watson gives Sheila a sedative, talk to her using the following responses:

❑ 1-2-2

Look at, then pick up, the perfume bottle from the makeup table. Look at the oily stain on the door (upper-right corner). Note the two-inch black hair. Search the rest of the room, then travel to Sarah Carroway's Flat.

SARAH CARROWAY'S FLAT

Talk to Watson using the following responses:

❑ 2-2-1-1

Open the umbrella and you'll find a small brass key. Look at the key, then pick it up. Open the brass caps of the bed posts. Open the teapot and gaze inside; note that the tea was brewed in the last 24 hours. Locate the sweater in the laundry basket. Remove the sweater from the basket and you'll notice an insignia from the Kensington Rugby Club. Read the journal, then travel to 221B Baker Street.

THE ANALYSIS

Let's analyze the powdery white substance and the flower. Not to worry—you don't have to be a rocket scientist to accomplish this. Begin by using the flower on the lab table, then use the flower on the microscope. Use the matches on the oil-wick burner. Use the flower on the flask and Holmes will automatically add nitric acid and silver nitrate to the warm-water bath. The dye used in the flower was an iodine-based substance. Exit the lab table scene. Use the powdery white substance on the lab table. Use the powder on the test tube and Holmes will automatically add sulfuric acid. Use the matches to light the burner, then use the powdery substance on the test tube. After Holmes adds zinc, a dark film will gather on the test tube—an indication of arsenic. Exit this scene, then leave the sitting room. Talk to Wiggins (young boy) using the following responses:

❑ 1-2

Give the flower to Wiggins. Now, before the Southwark Morgue icon will appear on the map screen, you must travel back to the murder scene. Once that's been completed, you can travel to the morgue.

SOUTHWARK MORGUE & SCOTLAND YARD

Welcome to Southwark Morgue. Begin by talking to the coroner using response No. 1. Attempt to pick up the key from the table and the coroner will inform you that you'll need proper authorization to take the key. To get authorization, begin by talking to Inspector Gregson. He'll tell you to talk to Lestrade at Scotland Yard. Travel to Scotland Yard. Talk to the constable. Try opening the door. Unfortunately, you won't be able to get into Scotland Yard without Inspector Gregson. So travel back to the morgue and look at the dead bodies. Talk to the Inspector using response No. 2. Once you're inside Scotland Yard, talk to the duty officer using the following responses:

❑ 1-1

Talk to Watson using response No. 2. He'll remind you of the blind apple vendor who has helped you in the past. Click the hand cursor on the door to exit Scotland Yard. Talk to the vendor using response No. 2. Click the hand cursor on the door

THE LOST FILES OF SHERLOCK HOLMES

and talk to the duty officer using the following responses:

❑ 1-2

When Inspector Lestrade approaches you, talk to him using response No. 1. He'll order Sergeant Duncan (the duty officer) to write a pass you must give to the Medical Examiner. To obtain this pass, talk to the duty officer. Travel back to the morgue and talk to the coroner using response No. 1. Pick up the large key and travel to the alley. Click the hand cursor on the backstage door. Use the large key to unlock it. Use the brass key on the chest of drawers and take the opera tickets. When Watson asks you a question, respond with choice No. 2. After Henry Carruthers gives you pertinent information about Miss Carroway's sister, travel to the opera house.

THE OPERA HOUSE

Talk to the manager using the first response during the entire conversation. Talk to the usher, then give him the opera tickets. Now give the tickets to the balcony usher and walk up the staircase. Talk to Mrs. Worthington. Give her the opera tickets and use the following dialogue responses:

❑ 1-1-1-1-2

She'll give you a note. Give this note to Fred Epstein, the manager, and he'll escort you to Carroway's dressing room. Unfortunately, he won't let you touch a thing in this room. Therefore click the hand cursor on the dressing room door. When you're back in the lobby, Watson will have an idea of how he can distract Fred Epstein. Talk to the manager to get back into the dressing room, then talk to Dr. Watson using response No. 2. After Watson and the manager have left, open the dresser drawer and quickly remove the contents (key ring) from the center drawer. Close the drawer and exit the dressing room. Travel to Belle's Parfumerie.

BELLE'S PARFUMERIE & SOUTH KENSINGTON FIELD

Use the inventory icon to view the perfume bottle you took from the makeup table in the theater. Talk to Belle using the following responses:

- 1-2-3-3-1

Talk to Belle again:

- 1-1-4



When Belle enters the back room, talk to the cleaning lady using response No. 1. Leave Belle's Parfumerie and travel to South Kensington Field. Talk to the coach several times. When he questions you about the brand of cigarettes that James smokes, use response No. 3 (Senior Service). Talk to James Sanders, then give him the perfume that you found on the makeup table in the theater's dressing room. Travel to Eaton Dormitory and talk to Mr. Sanders until you automatically leave the dormitory. Travel to 221B Baker Street. If Wiggins hasn't returned from the errand that you sent him on earlier in the game, walk one screen east, then return to 221B Baker Street. Talk to Wiggins using response No. 2. Next, talk to Jonas, the newsstand operator, using response No. 2. Talk to Wiggins again using response No. 2 and he'll give you a newspaper. Go back to Eaton Dormitory and talk to Sanders using response No. 2. Give Sanders the newspaper and use the following responses:

- 1-1-1-1

ST. BERNARD'S PUBLIC HOUSE

Once Sanders is convinced, travel to St. Bernard's Public House. Talk to the spectator using the following responses:

- 1-1

Talk to Nobby Charleton using the following responses:

- 1-1-2-1

Talk to the bartender using the following responses:

THE LOST FILES OF SHERLOCK HOLMES

❑ 5-1-3-1-1

Talk to Jack Mahoney (he's wearing a yellow suit) until you can choose response No. 2. Leave the bar and travel to Antonio Caruso's Flat. Talk to Antonio using the following responses:

❑ 1-1-3-1-2

Search the room. Look at the photograph on the table and the trophy on the mantel. Go to Anna Carroway's Flat and use the door knocker twice. Also, use the bell pull twice. To open the door, unlock it using the key ring. Look at the silver platter on the center table. Pick up a calling card from the silver platter. Click on the inventory icon to view the calling card. Walk upstairs and talk to the cleaning lady. Talk to Watson using response No. 1. Go back downstairs and move the plant nearest the staircase. Go upstairs and talk to the housekeeper. Tell her that you accidentally spilled some dirt on the rug. After she leaves, move the statue in the corner of the room. Look at the pedestal. Pick up the book (diary). Use the inventory icon to read the diary. Replace the statue and travel to the Law Offices of Mr. J. Farthington. Talk to Jacob using all the following responses:

❑ 1-1-1-1-1

Go to 221B Baker Street and talk to Wiggins. Convince him to give you his gyroscope. Once you have the gyroscope, you can travel to the Picnic Site & Playground. To lure the solitary boy closer to the fence, use the gyroscope on him. After conversing with the boy, give him the gyroscope. Did you notice that he placed his cap on the fence post? Pick up the cap and look at it using the inventory icon. Now you can travel to Eddington's Equestrian Shop. Talk to the counterman using response No. 1. Look at the coat of arms hanging on the north wall. After realizing that they are fakes, the counterman will tell you that the boy's cap was purchased by Lord Brumwell.

COVENT GARDEN

Travel to Covent Garden. Talk to the young flower girl, then move the wire basket of flowers from the barrel. Pick up the wire basket and use it on the barrel.

Open the door and enter the pub. Pick up the feather. Look at the picture with black bunting on the bar. Look at the picture of an elephant and rider hanging behind the bar. Talk to the publican using response No. 3. Look at the dart board. If you're in the mood for a game of darts, talk to the staggering drunk using response No. 2. After the arcade sequence, exit the pub and walk behind the flower girl. Travel to Bradley's Tobacco shop.

BRADLEY'S TOBACCO SHOP

Talk to the shopkeeper using the following responses:

❑ 1-1-1

Move the cigar crate and talk to the shopkeeper using response No. 2. Move the cigar crate across the room. Repeat this procedure with the remaining two crates. Stack the third crate atop the others. Climb the crates and look at the moose head. Pick up the moose head and you'll find the address of the taxidermy. Travel to Oxford Taxidermy.

OXFORD TAXIDERMISTRY

Talk to Lars using the following responses:

❑ 1-1-1-2-1

Pick up the smock. Look at the knife on the table. Pick up the knife. Talk to Lars again using the following responses:

❑ 2-2

Talk to Watson using response No. 2.

OLD SHERMAN'S

Travel to Old Sherman's. Talk to Sherman, then use the leash on the dog, Toby. When you reach the docks, open the shed door (left side of screen). Pick up the hammer and the strong rope. Move the right barrel. Climb onto the barrel and pick up the pail from the window sill. Move the barrel back to its original

THE LOST FILES OF SHERLOCK HOLMES

location. Pick up the blue rag. Use the pail on The Thames (water). Use the rag on the pail, then use the wet rag on the window. Look through the window, then talk to Watson using response No. 1. Use the hammer on the door. After encountering the two suspects, travel to Bow Street Police Court.

PART TWO: BOW STREET POLICE COURT

From within the Bow Street Police Court, talk to the guard using response No. 2. Travel to Scotland Yard and talk to the duty officer using response No. 2. Travel back to Bow Street Police Court and give the pass to the guard. Talk to the prisoner, George Blackwood, using the following dialogue responses:

❑ 1-1-1-1

Travel to Jaimeson's Buying and Selling.

JAIMESON'S BUYING AND SELLING EMPORIUM

Talk to the owner, Nigel Jaimeson, using the following responses:

❑ 1-3-1-1

Travel to Moorehead and Gardner Detective Agency.

MOOREHEAD & GARDNER DETECTIVE AGENCY

Talk to the receptionist using the following responses:

❑ 1-1-1-2

THE LONDON ZOOLOGICAL GARDENS

Travel to The London Zoological Gardens and talk to the constable, then open the gate. Walk one screen east and talk to Inspector Gregson using the following responses:

❑ 1-1-1

Talk to Constable Callaghan, then examine the body. Look at the slash wounds and his broken leg. Talk to the Inspector again using response No. 2. Look at the sign next to the door. Open the door and talk to Hollingston using the following responses:

❑ 1-1-1

Walk back to the elephant cage and follow the signs to the lion cage. Talk to Watson, then look at the shiny object in the lion's cage (later in the game you'll be allowed to get the shiny object). Walk two screens south, then travel to Simon Kingsley's Flat.

SIMON KINGSLEY'S FLAT

Talk to Simon using the following responses:

❑ 1-1

Look at the picture next to the door, then talk to Kingsley again using response No. 2. Look at the boots next to the fireplace. Talk to Kingsley a third time using the following responses:

❑ 3-1-2-1

Travel to The London Zoological Gardens and walk to the lion cage. Pick up the shiny object (watch). Use the inventory icon to examine the watch. Use the inventory icon again to read the piece of paper found in the watch. Travel to Moorehead and Gardner Detective Agency. Look at the portrait of Queen Victoria, then examine the framed photo (right side of screen). Talk to the receptionist using the following responses:

❑ 1-1

Pick up the old typewriter and enjoy the short animated sequence.

PART THREE

Travel to Bow Street Police Court and talk to the guard using the following responses:

❑ 1-2

Give him the pass and talk to the prisoner, Robert Hunt, using all responses. Travel back to M&G Detective Agency and talk to the receptionist using response No. 2. Open the door to the inner office. Move the comfy chair and pick up the piece of paper. Look at the paper. Move the books on the bottom shelf to reveal a wall safe. Use the piece of paper on the safe. Inside the safe you'll find a pendant. Look at the pendant and you'll find a note. Read the note, close the safe, replace the books, and move the comfy chair back to its original location. Travel to Lord Brumwell's Mansion. Move the bell pull. While in the foyer, look at the cigarette butts in the ashtray. Follow Lady Brumwell, then talk to her using the following responses:

❑ 2-2

Open the double doors and talk to Lord Brumwell. To get out of the locked room, first move the left Persian sword hanging above the fireplace. Next open the large painting, then open the unlocked safe. Pick up the safe's contents (small brass key). Use this key to unlock the double doors. Leave the mansion and you'll see a short animated sequence. Leave 221B Baker Street and travel to Robert Hunt's flat. Open the small book on the nightstand. Look at the book, then pick up the bookmark (claim ticket). Open the chest at the foot of the bed. Use the iron bar on the chest to reveal a hidden compartment. Pick up the document and examine it. Travel to Jaimeson's Buying and Selling. Give the pawn ticket to the owner and he'll give you a box of Tarot cards. Look at the cards. Travel to Covent Garden and walk into the passage (left side of screen). Move the left candle. Look at the strong box. Use the ornate key to unlock the drawer of the writer's desk. Open the drawer and pick up the silver key. This key will unlock the strong box. Inside you'll find a folded piece of parchment. Pick up the parchment and examine it. Finally, travel to Savoy Street Pier and look into the window. Use the iron bar to open the door and enjoy the final animated sequence.

LOCATION OF OBJECTS

- Blue Rag Docks
- Calling Card Caruso's Flat
- Cap Solitary Boy
- Cigarette Butts Murder Scene
- Claim Ticket Hunt's Flat
- Diary Caruso's Flat
- Document Hunt's Flat
- Dog Old Sherman's
- Feather Pub
- Flower Theater
- Gold Spring Theater
- Gyroscope Wiggin's
- Hammer Docks (Shed)
- Handwritten Card Theater
- Iron Bar Murder Scene
- Key Ring Dressing Room
- Knife Oxford Taxidermy
- Large Key Morgue
- Leash Old Sherman's
- Matches Lab Table
- Newspaper Wiggin's
- Nitric Acid Lab Table
- Note Mrs. Worthington
- Opera Tickets Theater
- Pail Docks (Window Sill)
- Parchment Covent Garden
- Pass Duty Officer
- Pendant Safe (Detective Agency)
- Perfume Bottle No. 1 Theater
- Perfume Bottle No. 2 Belle's Parfumerie
- Piece of Paper Detective Agency
- Playbill Murder Scene

THE LOST FILES OF SHERLOCK HOLMES

- Silver Key Covent Garden
- Silver Nitrate Lab Table
- Small Brass Key No. 1 Umbrella (Carroway's Flat)
- Small Brass Key No. 2 Safe (Brumwell's)
- Smock Oxford Taxidermy
- Strong Rope Docks (Shed)
- Sulfuric Acid Lab Table
- Tarot Cards Jaimeson's
- Watch Lion Cage
- White Powder Murder Scene
- Wire Basket Covent Garden
- Zinc Lab Table

CHAPTER 23

REX NEBULAR

GRAPHICS:	☆☆☆	STORY LINE:	☆☆
ARCADE:	N/A	INTERFACE:	☆☆☆
DIALOGUE:	☆☆	AUDIO:	☆☆
ANIMATION:	☆☆☆☆	LENGTH:	☆☆☆
OVERALL ANALYSIS: ☆☆☆			

SYSTEMS

- MS-DOS IBM-PC/Tandy & Compatibles

FEATURES

- Mind-expanding state-of-the-art graphics that combine drawn, digitized, 3-D rendered, and rotoscoped art!*
- A multitude of mind-bending puzzles!*
- Enticing skill levels for players from novice to genius!*
- Impossible-to-put-down manual written by award-winning game designer Steve Meretzky!*



SCENARIO

The people at MicroProse Software have ventured forth from their staple product line—consisting mainly of simulations—into the adventuring world with *Rex Nebular: And the Cosmic Gender Bender*. This science-fiction quest takes you, a promiscuous space-cowboy known as Rex Nebular, on a seemingly endless journey to dozens of cosmic locations. You begin on the redoubtable starship the *Slippery Pig*. But when a vessel piloted by wrathful Amazon women nearly blasts you into space junk, you're forced to crash land on an strange planet inhabited entirely by alien vixens. Your quest quickly descends into uncertainty when you teleport to other strange worlds like a male-dominated, underground complex known as Machopolis. The interface boasts rotoscoped animation of the objects in inventory—the icons do, however, take up one-third of the viewing screen. *Rex* also gives you the option to adjust the proficiency level from novice to expert. When set to *Novice* and your character encounters a death sequence, the game automatically restores itself—thus making it less arduous to play. Rumors have surfaced that a sequel's already in the works. And the sequel is said to outperform its predecessor in both animation and graphics—I can't wait!

WALK-THROUGH

Note: The following hints are for the Expert proficiency setting.

THE SLIPPERY PIG

After the 10-minute introduction, you'll find yourself on the bridge of the *Slippery Pig*. Look at the view screen (don't miss this step if you're in *naughty* mode). Examine the rest of the cockpit, then walk to the life-support section of the ship. Approach the refrigerator and take the burger. Take the binoculars hanging next to the *nudie* poster. Walk into the engineering room. Take the brown rebreather from the floor behind the workbench. Take the timer module from the workbench. Attempt to take the tasty turkey, then leave the engineering room and ascend the ladder to reach the airlock. Swim one screen east and one screen south. Take the dead fish. Now put the burger in the dead fish. Swim one screen east and throw the *stuffed* fish at the small hole next to the underwater cavernous opening. Swim through the tunnel. Once ashore, walk through the cave entrance. Walk one screen north and one screen west. Enter the Witch Doctor's hut and take the poison darts from the table. Exit the hut and walk one screen west. After the monkey swipes your binoculars, walk one screen west. Talk to the native woman using the following responses:

☐ 2-1-2-3

After performing to your utmost potential, take one twinkifruit and exit the hut. Walk four screens east and take the plant stalk next to the palm tree. This stalk can be used as a

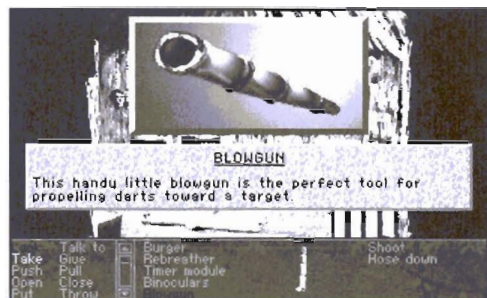

REX NEBULAR

blowgun. Talk to the monkey in the palm tree. Load the blowgun with the poison darts, then propel a dart in his direction. Retrieve your binoculars. Now you must defeat the wrathful man eater. Do this by walking one screen west. Take the pile of leaves and place them over the open pit. Place the twinkifruit on the leaves.

Walk two screens north and grab two (2) bones. Climb the ladder of the lookout tower and use the binoculars to observe the stranger in the distance.

Hint: Write down the coordinates! They're different in every game.

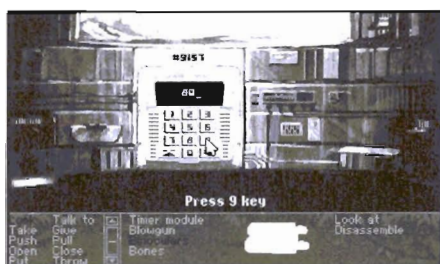

After jotting down the randomly generated coordinates to the underground complex, walk one screen south, then one screen north. Enter the teleporter. Punch in the correct coordinates, then strike the key with the smiling face (lower-right quadrant of keypad).

THE UNDERGROUND COMPLEX

After Lt. Xina escorts you to your very own holding cell, you'll hear a strange voice coming from one of the other cells. Talk to the west wall (prisoner) using the following responses:

1-1-2-1-3-3-1-1-1

When you're on a gurney in the medical facility, talk to the intern using the following dialogue responses:

1-1-2-1-2-1-1-1-2-1-1-1

Immediately after the intern leaves the room, grab the scalpel from the instrument tray. Wait for Dr. Slache to interview you and use the following responses:

2-2-1

When you're back in the holding cell, pry open the air vent using the scalpel. Climb into the ventilation system. Crawl west until you reach the security station. Open the grate, then sit at the desk. Press the red button (on the left monitor) twice. This will disable the cell's laser beams. After a brief animated sequence, walk two screens west and step onto the platform of the Gender Bender.

After your horrifying sex change, walk one screen east and two screens north. Take the guard's detached arm and place it on the scanner. Retrieve your belongings. Before leaving this room, take the tape player near the left side of the screen. Walk one screen north (through doorway) and take the credit card chip from the dead guard. Walk four screens south and enter the barroom. Sit on the middle stool and eavesdrop on the conversation between the repair woman and the bartender. Follow the path of the flashing arrows and take the repair list from the repair woman's back pocket. Read the repair list. Talk to the bartender using the following responses:

2-3

To pay for the distilled tribble juice vodka, use the credit card chip (response No. 2). Before leaving the bar, take the credit card chip. Exit the barroom and walk one screen south, two screens east, and one screen north. You should now be in the medical examination room. Attempt to retrieve the tape player from the dead body. You'll soon realize, however, that you can't take the player—but you can get the audiocassette. Put the audiocassette in *your* tape player and activate it. Walk three screens west and take the security card from the bloody cell. Walk three screens west and two screens south. Put the security card in the card slot of the Armory. Enter the Armory and take the target module from the chest. Exit the Armory. Walk one screen east and place the security card in the card slot of the storage room. Enter the storage room. Take the charge cases from the cardboard box (left side of screen). Exit the storage room and enter the laboratory (first door to the right of the storage room). Find and take the following items:

- Flask of petrox
- Flask of lecithin
- Flask of formaldehyde

REX NEBULAR

Use the following instructions to concoct an explosive charge:

- Dollop of formaldehyde
- Dash of lecithin
- Splash of alcohol
- Drop of petrox

Hint: Activate the tape player.

Carefully place the charge cases into the explosives (kettle). Exit the lab and walk two screens west, four screens north. Enter the teleporter. If your gender's female, enter the coordinates for Terra Androgen. If you've forgotten the coordinates, refer to the repair list. If the Gender Bender has worn off, you must transform back into a female before traveling to Terra Androgen.

When you're near the weather station, walk three screens south, three screens west, and one screen north. Talk to the native woman using the following responses:

- 2-3-3

Take the chicken on the spit. Walk back to the teleporter and enter the coordinates for the underground complex. Use the Gender Bender to change back into a male. Go back to the teleporter and use the repair list to find the coordinates for Machopolis. (If you see a skeleton on a railing, you've found Machopolis.)

MACHOPOLIS

From the teleporter on Machopolis, walk one screen west and enter the vehicle. Activate the controls by clicking the cursor on the view screen. A 3-D map of the underground complex will appear. The red box is your current location. To the right of the map are three buttons. Press either arrow button to select a destination. Press the teak-colored button to activate the car. Now push the black arrow button twice and the address should read:

- 14 Powertool Ave.

Activate the car by pressing the teak-colored button and enjoy the ride to the Sandbar Restaurant. Enter the restaurant and take the fishing pole from the back wall. Walk behind the counter and open the cash register. Take the padlock key. Exit the Sandbar Restaurant. Forget about Polly's Pleasure Dome—you'll *never* get inside. Enter the vehicle and activate the controls. Travel to the following address:

❑ *14 Dresset Crossing*

Enter Bruce's humble abode. Walk one screen east and take the compact case from the vanity. I know you've found Bruce's safe—and, being the master adventurer that you are, you've probably tried like heck to get it open. But you can't open it this early in the game, so travel to the following location:

❑ *226 Biceps Way*

Enter the laboratory and what do you see? Why, it's a giant laser cannon! That cannon, by the way, is your ticket to opening the safe in Bruce's home. To activate the laser, pull the red lever (left side of cannon). Place the compact case on the bull's-eye to *reflect* the laser beam—sending it through the ceiling and into Bruce's living room. But before you go safe-cracking, you'll need another mirror and a few other items. Exit the laboratory and enter my favorite store—the software store. Take the penlight from the counter. Travel to the following location:

❑ *Maintenance Access*

Use the padlock key you found in the cash register at the Sandbar Restaurant to unlock the control box. This will lower the dthingy to the street. Use your vehicle to travel to the following location:

❑ *818 Widepipe Lane*

Save the game! To get past the rabid dog, throw a bone over the fence.

Hint: *If you don't have any bones, two can be found next to the lookout tower on the surface of Terra Androgena. Two more bones can be found at 34 ½ Lonely Way (upper level).*

Immediately after the dog disappears, enter Abdul's Service Station. Once inside, that pesky mutt will leap through the broken window. Throw a bone at the *danger zone* below the vehicle. When the dog attacks the bone, press the button (left side of garage) to lower the lift. Once the mutt is mincemeat, find and take the polycement tube from the toolbox. Take the rearview mirror from the storage box. Now it's time to open the safe in Bruce's home. Travel to the following location:

❑ *14 Dressed Crossing*

Use the rearview mirror to deflect the laser beam. Open the safe and get the door key. Travel to the following location:

❑ *4 Monument Street*

Using the door key, *unlock* the entrance door to Buckluster Video. Take the phone handset from the cradle. Disassemble the handset. Disassemble the penlight. Place the Durafail cells into the handset. Put the phone handset on the phone cradle—this will charge the dead batteries. Exit the video store, then reenter it. Take the phone handset and disassemble it. Make sure the batteries are fully charged. Exit the video store and WALK toward the back alley. Talk to the hermit using the following responses:

❑ 2-2-3-4-4-4-4-4

He'll give you a fake I.D. card in exchange for four fully charged batteries. Travel to the following location:

❑ *14 ½ Lonely Way*

Put the fake I.D. card in the card slot of the elevator. Note the three cement pylons along the platform. Disassemble the fishing pole (you found the pole at the Sandbar Restaurant) and tie the fishing line to the hook of the smallest pylon. Walk one screen east and take the real I.D. card from the pile of bones.

Hint: DO NOT use this teleporter—unless, of course, you want to end up like that poor fellow scattered about the pavement.

Enter the vehicle and travel to the following location:

14 Powertool Avenue

Take the fishing line and tie it to the boat. Now travel to the following location:

City Periphery: City Security

Put the real I.D. card in the card slot near the huge overhead door. Take the detonators from the white cardboard box. Travel to the following location:

City Periphery: North Sea Window

Now you must assemble a timebomb. To do this, put the detonators on the charge cases; put the timer on the bombs. Now place the timebomb on the viewport. Travel to the following location:

34 ½ Lonely Way

Put the I.D. card in the card slot of the elevator. Walk behind the cement pylons and wait for the explosion. After the city floods, pull the fishing line to retrieve the boat.

THE VASE

To evade the one-eyed sea monster, place the bomb into the chicken. Throw the

REX NEBULAR

chicken/bomb device at the sea monster. Steer toward the north building. Before docking, take the floating bottle and fill it halfway with seawater. Enter the building. Put the half-full bottle on the pedestal containing the purple vase. Enter the teleporter and key in the coordinates to the airfield (the coordinates can be found on the repair list).

THE AIRFIELD

Look at the control panel. Press the start button (No. 2). Press the top-right (green) button. Exit the panel scene. Walk through the east doorway and approach the damaged ship. Take the shield modulator and the remote. Walk one screen east and enter the spaceship. Look at the cracked windshield. Put the polycement on the crack. Look at the service panel. Install the shield modulator and the target module. Exit the service panel scene. Activate the remote control, then pull the throttle. Enjoy the final animated sequence.

CHEAT MODE

Note: The following hints must be used with caution. USE THEM AT YOUR OWN RISK!

The “cheat mode” is intended for experienced programmers only. Certain key-combinations can produce unpredictable results. Therefore, use them with extreme caution. To activate the cheat mode, save the game, then strike the following keys respectively:

☐ Ctrl-W I D E P I P E

The following codes (among others) are available in cheat mode:

TELEPORT

- Ctrl-T
- Slippery Pig* 101, 102, 103
- Underwater 104-109
- Cave 110, 111
- Isle (South) 212
- Isle (East) 203, 208, 209
- Isle (North) 201, 202
- Isle (West) 205, 207, 210, 211
- Witch Doctor 214
- Twinkles 215
- Air Vent 313
- Cells 307, 357
- Guard Station 311, 361
- Gender Bender 316
- Intersection 354
- Vault Room 352
- Teleporter Room 351
- Scanner 401, 407
- Bar 402
- Armory 408
- Storage Room 410
- Laboratory 411
- Teleporter 413
- Restaurant 511, 512
- Software 506, 507, 508
- Elevator 513
- Bruce's Home 601-603
- Seaview 604
- Abdul's Place 607, 608
- Buckluster 609, 610
- Hermit 611
- Williams's 612

- Sea Monster 703
- Bottle 704
- Penthouse 705/706
- Control Room 801
- Pad One 802
- Pad Two 803
- Spaceship 804

DETERMINING ROOM

NUMBER

- Ctrl-P

MOVE OBJECTS

- Ctrl-O

CHANGE GLOBAL FLAGS

- Ctrl-Z (*USE WITH EXTREME CAUTION!*)

LOCATION OF OBJECTS

- Audiocassette Medical Facility
- Batteries Phone Handset, Penlight
- Binoculars *Slippery Pig*
- Bones Near Lookout Tower
- Bottle North Sea
- Burger Refrigerator, *Slippery Pig*
- Charge Cases Storage Room (Underground Complex)
- Chicken Native Woman
- Compact Case Vanity (Bruce's Home)
- Credit Card Chip Underground Complex (Dead Guard)
- Dead Fish Crash Site
- Detached Arm Underground Complex
- Detonators City Security
- Door Key Safe (Bruce's Home)
- Fake I.D. Card Hermit (Back Alley)
- Fishing Line Fishing Pole
- Fishing Pole Sandbar Restaurant
- Formaldehyde Laboratory (Underground Complex)
- Lecithin Laboratory (Underground Complex)
- Padlock Key Cash Register (Sandbar Restaurant)
- Penlight Software Store
- Petrox Laboratory (Underground Complex)
- Phone Handset Buckluster Video
- Pile of Leaves Next to Deep Pit
- Plant Stalk (blowgun) Palm Tree (Monkey's Hideout)
- Poison Darts Witch Doctor's Hut
- Polycement Abdul's Service Station
- Real I.D. Card Pile of Bones (14 ½ Lonely Way)
- Rearview Mirror Abdul's Service Station
- Rebreather *Slippery Pig*

- Remote Control Damaged Ship (Airfield)
- Repair List Repair Woman's Back Pocket (Bar)
- Scalpel Instrument Tray (Medical Facility)
- Security Card Bloody Cell (Underground Complex)
- Shield Modulator Damaged Ship (Airfield)
- Tape Player Underground Complex
- Target Module Armory (Underground Complex)
- Timer Module *Slippery Pig*
- Twinkifruit Native Woman's Hut
- Vase Pedestal (North Sea Building)
- Vodka Bar (Underground Complex)

CHAPTER 25

AMAZON

GRAPHICS:	☆☆	STORY LINE:	☆
ARCADE:	☆	INTERFACE:	☆☆
DIALOGUE:	☆	AUDIO:	☆☆
ANIMATION:	☆☆	LENGTH:	☆☆☆
OVERALL ANALYSIS: ☆☆☆			

SYSTEMS

- MS-DOS IBM-PC/Tandy & Compatibles

FEATURES

- Amazon can be played in both standard VGA and Super VGA mode.
- In Super VGA mode, the Inventory Screen is always displayed, showing all the items at your disposal and giving you quick access in the middle of fast-paced action.
- Multiple windows give you a more comprehensive view of the game and each chapter sequence, as well as the ability to toggle back to previous scenes for information you may have missed earlier.

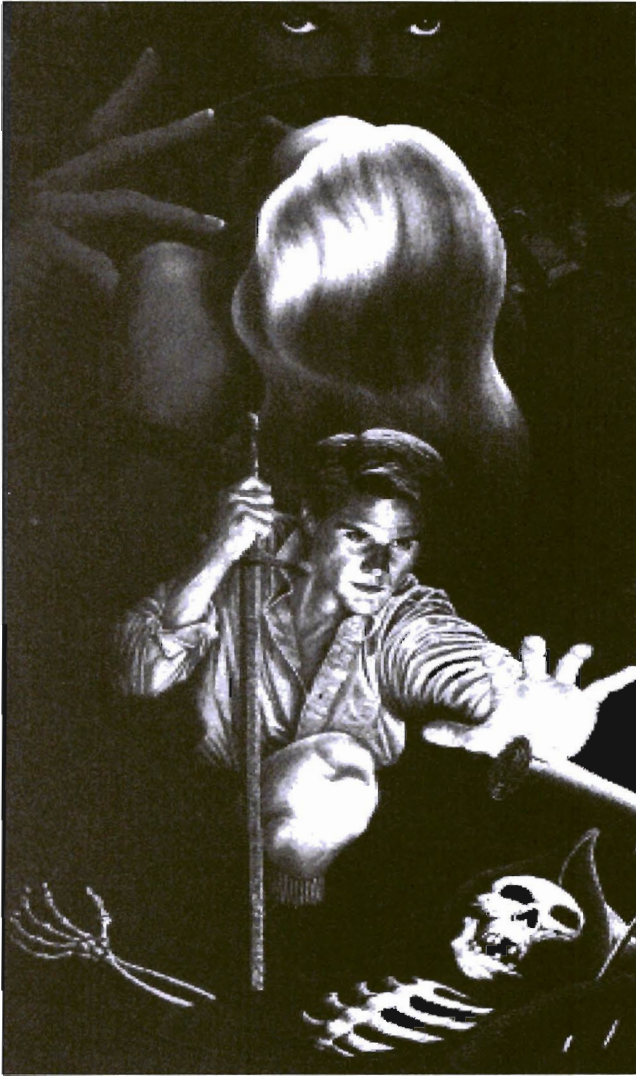

SCENARIO

Amazon: Guardians of Eden is a campy adventure released by Access Software. You play the role of Jason Roberts, a recent college graduate, who sets forth on an expedition to the Cimmerian heart of the Amazon Basin. A desperate, daft message immediately alters Jason's plans—sending him on a perilous quest to a land where legends come to life, danger lurks behind every corner, and every sought-after treasure lies shrouded in mysticism. *Amazon* allows you to view the playing field in SVGA (after installing a VESA BIOS extension). Although SVGA mode may sound great, in this case it lessens gaming enjoyment because of the squint-

eyed size of the main action screen (it's about half the size of the standard VGA viewing window). Although *Amazon* does include mouse support, I've found that the main characters are sometimes very difficult to maneuver—even requiring the use of the keypad. Furthermore, since this adventure is “time-sensitive”—requiring unknown (or should I say *unjust*?) arcade-like responses in the timeframe available—plan to restore often.

WALK-THROUGH

CHAPTER 1

Enter the Allister Research Center. The first door on the right leads to Jason's laboratory. After entering the lab, open the rat cage and place the rodent in inventory. Open the center cabinet and take the bottle of alcohol. After pushing the button on the intercom, you can exit the lab.

Get the rat from inventory and click it on the receptionist. After her hasty departure, walk west (past the desk) and open the mahogany key case. Take the left and center keys from the bottom row. Enter Allen Roberts's lab. Open Dr. Roberts's journal (red book on west counter). Look at the journal. Now open the book containing medicinal cures (red book next to projector). Read the book. Pull down the movie screen. Pick up the movie (from center counter) and place it in the movie projector. Turn on the projector.

Hint: Remember the title of the movie—“*Wild Women of Wongo.*”

Turn off the projector. Use the display case key to unlock the display case. Take the sulfur-based compound (jungle potion), then exit the lab. Walk west to reach the end of the corridor. Enter Thornick's office. After a short animated sequence, you'll automatically travel to Jason's apartment. Look at the package near the door. Next to the tape player you'll find a letter opener. Use the letter opener to open the package. Look at the contents of the package (letter) and Chapter 1 will end.

CHAPTER 2

Begin Chapter 2 by picking up the key from the package. Then exit this screen. Again you'll find yourself in the parking lot of the research center. Walk behind the green vehicle and use Flich's car keys to open the trunk. Pick up the crowbar and the bolt cutters. Now enter the building. Walk west and enter Allen's

laboratory. Use the cabinet key (which you took from the package) to unlock the center cabinet. Pick up the reel-to-reel audio tape and place it in inventory. Did you notice the dart next to the dart board? Take the dart and the blowgun from atop the display case. Exit the lab.

Walk east to exit the building. Now use Jason's car keys on the red car. After a short animated sequence, you'll arrive at Jason's ransacked apartment. Catch your breath and use the reel-to-reel audio tape on the tape player. Click the red button and you'll acquire the combination to a safe. Locate the Little Orphan Annie Decoder Ring (glistening dot) near the armrest of the overturned chair. Pick up the ring and read the dialogue window carefully. Exit the apartment and you'll automatically travel back to the parking lot of the Allister Research Center.

Enter Allen's lab. Move the dart board and you'll find a safe. Use the combination from inventory to unlock the safe. Grab the loot, then exit the laboratory. Walk east and enter Jason's lab. Click on the inventory icon and drag the jungle potion over the alcohol. Place the beaker on the Bunsen burner. Turn the knob to ignite the Bunsen burner. When the potion turns green, turn off the Bunsen burner and take the beaker. Click on the inventory icon and drag the dart over the green potion and you'll have a *dipped dart*. Exit the lab.

Walk west and enter the security vault via the double doors. Climb up the tree stump and click on the inventory icon. Drag the dart over the blowgun. Click the loaded blowgun on the pacing (male) guard when his back's facing you.

Hint: *The following sequence is time-sensitive.*

Clamber down the tree stump and run to the garbage can. Quickly use the bolt cutters to cut the chain. Grab the key (next to the pair of pants), then run to the stone guard house. Walk toward the oxidized iron plate doors. Use the guard's key to unlock the steel doors and Chapter 2 will end.

CHAPTER 3

Begin Chapter 3, oddly enough, by leaving the security vault. To rid this place of the security robot, B.O.B., you'll need a disguise. And what better disguise is there than a garbage can!? Get the garbage can and enter the security vault. After B.O.B. leaves, pull the red lever. A panel will slide open, revealing four drawers. Use the crowbar to open the lower-right drawer. There you'll find a roll of microfilm, a piece of a map, and an ancient compass. After placing these items in inventory, use the arrow keys (on the keypad) to exit this screen.

Walk east, past the library, and you'll reach a coat rack. Take the right hanger and exit the building. Walk to the driver's-side door of the blue-and-white car. Use the coat hanger to jimmy open the door. When a window of the dashboard appears, turn on the vehicle's lights by pulling the left knob. Close the car door. Enter the building and walk west. Talk to the librarian using response No. 1. When she leaves, you'll have access to the microfilm viewer. Place the microfilm on the square between the knobs (arrows). Click on the left arrow button to scroll through the microfilm. After reading about the ancient emeralds, exit this screen and use Jason's car keys on the red-and-white car. I'll see you in Cuzco.

CHAPTER 4

Welcome to Cuzco. Begin by opening the tanker-truck's door and you'll see an object tumble to the ground. Get the cigarette pack. Walk to the rear of the truck and take the jerry can. Next to the bicycle (leaning against the observation tower) you'll find a bicycle pump. Take the pump, then enter the Puerto Cuzco (yellow building). Talk to the ticket agent using the following responses:

❑ 1-1-1 *Offer*

Click on the inventory icon and give Jose Cortez some cash. In return, he'll give you a card that you must give to the bartender at the Green Monkey. Enter the bar and talk to the bartender. Give him the card by clicking on the offer icon. Talk to the pilots (sitting at the table) and you'll automatically find yourself aboard an airplane. Examine the cargo until the pilot steps through the door.

CHAPTER 5

So far so good. Now, when the pilot barges in (waving a gun at you), use the following responses:

- 1-2-2

When the pilot says *I'm waiting*, open the latch of the chicken coupe. Now take the parachute and tie it to the cabin door. To land the airplane, use the following sequence:

- Pull back the wheel
- Move the flap lever (to the right of the wheel)
- Pull the throttle

Save the game, then hustle through this time-sensitive sequence. Open the center crate and remove the rubber raft. Click on the inventory icon and combine the bicycle pump with the rubber raft. Now quickly place the raft in the river. This concludes Chapter 5.

CHAPTER 6

After a short animated sequence, you'll find yourself in Rio Blanco. Use the arrow keys to walk toward the pepper cart. Steal some peppers. Walk into the Cantina (brown building). Approach the bar and talk to the female cook. When she turns her back, get the paring knife from atop the counter. Click on the inventory icon and combine the knife and the peppers: This will give you *chopped peppers*. Wait for the cook to turn her back, then place the chopped peppers on the plate of food. Exit the Cantina, then immediately reenter the restaurant. Walk to the first table and (when the cook's back is turned) snatch the enchilada and the coins (tip). Walk to the second table and (when the cook's back is turned) grab the lighter. Exit the Cantina. Walk to the hotel (red building). Open the door and enter the foyer. Pick up the rat trap from the staircase. Combine the enchilada with the rat trap. Place the baited trap on the staircase. After trapping the rat, grab the wallet from the rat hole. Place a peso into the coin slot of the telephone. Pick up the receiver and click on the dial. After the phone

AMAZON

rings three times, break the connection.

Hint: *After the telephone rings three times, break the connection.*

Exit the hotel and walk toward the shoreline. Get the small wooden pole. Walk to the trading post and purchase the following items:

- Paddle
- Barbasco root
- Ammunition
- Machete
- 12-foot fishing throw net

Enter the Cantina and wait for Maya to appear. Talk to her using the following dialogue responses:

- 2-3-3-2

Exit the Cantina. Get the ladder (it's leaning against the Cantina). Place it against the west wall of the hotel. Climb the ladder. Using the small pole, knock down the sign above the arguing men. After climbing down the ladder, the peasant boy will give you a gold nugget. Save the game, then climb into the canoe.

CHAPTER 7

Save the game, then follow these directions precisely:

- Give Allen the ammunition.
- Move the heavy piece of corrugated iron.
- Move the heavy beech-wood log (bottom-left of screen).
- Switch character roles to Maya.
- As Maya, take the jungle vine.
- Walk across bridge to break.
- Repair break with jungle vine.

After Maya crosses the bridge, character control will automatically return to Jason. Walk across the bridge and enjoy the short animated sequence. Talk to the Captain using the following responses:

- 1-1-1 *Offer*

Give the Captain the cigarettes and the gold nugget. This concludes Chapter 7.

CHAPTER 8

Start this chapter by placing the poison root (which you purchased at the trading post) into the river to kill the piranhas. Now wait for the guard in red to disappear behind the cabin of the ship. Quickly walk east and pick up a hollow reed. Wade into the river. After the guard in red reaches the blind side of the cabin, climb aboard the *Amazon Queen*. Take the fishing pole from the deck. Peer into the porthole of the Captain's cabin. Locate the key ring and retrieve it using the fishing pole. Click on the exit icon. Walk west, then north. To elude the guard, hide behind the crates. From inventory, get the *Amazon Queen* keys. Walk to the mate's cabin and quickly unlock the door. Enter the cabin and you'll find Maya bound and gagged. Before freeing her, move the zinc-coated iron bar (to bar the cabin door). Get the greasy rag. Open the medicine cabinet and take the bottle of 190-proof cane rum. Now you can free Maya by cutting the ropes with the knife. Open the porthole, then click on the inventory icon. Construct a molotov cocktail by combining the following items in order:

- Greasy rag
- Bottle of rum
- Lighter

Throw the molotov cocktail through the open porthole and wait for the Captain to yell *Fire on deck!* Quickly remove the iron bar and open the cabin door. After a short animated sequence, you'll approach several thatched huts.

Hint: *The following sequence is time-sensitive.*

Okay, you must find a way to heal the young Indian boy. Begin by having Jason move the rock near the fork in the river. Quickly pick up the worm before it slithers into the water. Walk to the west hut and pick up the ladle. Approach the river and use the throw net to catch the floating crate. Now combine the fishing pole and the worm. Click the fishing pole on the river and you'll catch a green fish. Switch character roles to Maya. Walk north, then east (over bridge) and get the green-and-red jungle plant. Cross the bridge and walk west toward the large black cauldron. Place the following ingredients into the cauldron:

- Jungle plant
- Fish
- Jerry can

To heat the contents, place the cauldron over the campfire. Use the ladle on the cauldron. Click the filled ladle on the sick Indian boy and Chapter 8 will end.

CHAPTER 9

Begin the new chapter by saving the game. Now use the arrow keys to maneuver the canoe while avoiding the boulders. You'll notice that the river forks at several locations. Follow the procedure below to get through the river puzzle:

- Left-Right-Right-Left (Down-Up-Up-Down)

Save the game during the previous procedure: You'll need to restore often—*much too often!* After weaving your way through this annoying arcade sequence, you'll have the pleasure of meeting Hans Stroheim, the archaeologist. When he expects a response, click on the offer icon and give him the map and the compass. Hans will tell you to find the "Eyes of the Jaguar" at the region of the jungle known as Sitio Maldito. Walk west and pick up the sturdy wooden plank. Place the plank on the large boulder in the center of the screen. Change character control to Maya and have her stand on the west end of the plank. Change character control back to Jason and have him climb the tree stump. After a short animated sequence, have Maya climb the vine (be careful not to fall off the

platform). Attached to the platform you'll see a thick, green tree vine. Click on this vine and Maya will swing to the east platform. Drop the rope to Jason. Have Jason climb the rope. Return control to Maya and walk to the east end of the platform. Have Maya enter the basket. Change control to Jason. Pull the rope to raise the basket (Maya) to the utmost platform. Have Maya exit the basket.

CHAPTER 10

Enter the hut. Get the key from around the ancient conquistador's neck. Use the key to unlock the wooden chest. Pick up the scroll and read it. Use the machete to hack through the thick, gnarled pile of vines and leaves. Use the machete on the breast plate of the warrior skeleton. Take the green emerald and exit the hut. After a short animated sequence, you'll return to Hans Stroheim's hut. He'll give you the directions to the massacre scene. And again you endure another annoying arcade sequence:

❑ Right-Left-Left-Right (Up-Down-Down-Up)

CHAPTER 11

After placing Maya in control, walk to Daniel Holbrook's tent. Open the tent flap and pick up the jerry can. Walk to the rear of the jeep and click the jerry can on the gas tank. Click the hand cursor on the gas cap. Walk to the front of the jeep and unwind the winch cable by simply clicking on it. Walk to the dead body leaning against Holbrook's tent. Next to the body you'll find a chain. Get the chain. Walk to the fallen log and click the chain on the log. Change control to Jason and walk to the dead body of Don Emschwiller. Pry the keys from his stiff hand. Walk to the vehicle and click the key on the jeep. Venture to the front of the jeep and click on the operating lever for the Ramsey winch. Switch control to Maya. Move the tarp to uncover a wooden Coca-Cola transport case. Open the case and gingerly extract the explosives. Walk to the watertight aluminum case (center of screen). Open it and remove the Geiger Mueller Radiation Counter. Use the Geiger counter to locate the arrowhead (it's within the twisted jungle vegetation behind jeep). Move the bush and take the arrowhead. Click on the exit

icon and you're back in that confounded canoe:

- Right-Right-Right-Left-Right (Up-Up-Up-Down-Up)

CHAPTER 12

From the waterfall, follow the bloody path. Move the tree limb to reveal a secret door. Use the arrowhead on the door carving. After entering the covered bridge, walk to the second pillar while avoiding the arrows. Wait for the Colonel to yell, "Kill them all!" Then click on the inventory icon and combine the lighter with the dynamite. Drop the lit explosives near the second pillar and run north. The bridge will explode, killing the Colonel and his men. This concludes Chapter 12.

CHAPTER 13

Save the game. From within the pit, walk over to the boots and take the shoelaces. Pick up the broken spear. Use the knife to cut the vine flower dangling from above. This will cause sap to drip from the vine. Quickly move the turtle shell to the east end of the room. Climb on the turtle shell and snatch the torch. Click on the inventory icon and combine the following items to kill the ant:

- Shoe laces
- Broken spear
- Knife

LOCATION OF OBJECTS

- Alcohol Jason's Lab
- Ammunition Trading Post
- Ancient Compass Security Vault
- Arrowhead In Bush Behind Jeep (Campsite)
- Barbasco Root Trading Post
- Bicycle Pump Next to Bicycle (Cuzco)
- Blowgun Allen's Lab
- Bolt Cutters Fritch's Car
- Bottle of Rum Mate's Cabin
- Broken Spear Pit
- Chain Dead Body (Holbrook's Tent)
- Cigarette Pack Tanker Truck
- Coat Hanger Corridor, Allister Research Center
- Coins Cantina
- Crowbar Fritch's Car
- Dart Allen's Lab
- Decoder Ring Jason's Apartment
- Emerald Conquistador (Tree Hut)
- Enchilada Cantina
- Explosives Under Tarp (Campsite)
- Fish River at Thatched Huts
- Fishing Pole Deck of the *Amazon Queen*
- Floating Crate River at Thatched Huts
- Garbage Can Guard Station
- Geiger Counter Box (Campsite)
- Gold Nugget Peasant Boy (Rio Blanco)
- Greasy Rag Mate's Cabin
- Guard Key Guard at Security Vault
- Hollow Reed Near Shoreline
- Jerry Can (1) Tanker Truck
- Jerry Can (2) Tent (Thatched Huts)
- Jungle Plant Thatched Huts

AMAZON

- Jungle Potion Allen's Lab (Display Case)
- Key Ring Captain's Cabin
- Keys (Cabinet) Package (Jason's Apartment)
- Keys (Display case) Mahogany Key Case
- Keys (Flich's car) Mahogany Key Case
- Ladder Cantina
- Ladle Thatched Huts
- Letter Opener Jason's Apartment
- Lighter Cantina
- Machete Trading Post
- Map Piece Security Vault
- Microfilm Security Vault
- Money Safe in Allen's Lab
- Paddle Trading Post
- Parachute Cargo Area of Airplane
- Paring Knife Cantina
- Peppers Pepper Cart (Cuzco)
- Rat Jason's Lab
- Rat Trap Hotel (Cuzco)
- Red Card Jose Cortez
- Reel-to-Reel (Audio) Cabinet (Allen's Lab)
- Safe Combination Tape Player (Jason's Apartment)
- Scroll Wooden Chest (Tree Hut)
- Shoelaces Boots in Pit
- Throw Net Trading Post
- Torch Pit
- Wallet (peso) Hotel in Cuzco (Inside Rat Hole)
- Wooden Plank Sitio Maldito
- Wooden Pole Shoreline (Rio Blanco)
- Worm Under Rock (Thatched Huts)

CHAPTER 25

ULTIMA UNDERWORLD

GRAPHICS:	☆☆☆☆	STORY LINE:	☆☆☆☆
ARCADE:	☆☆☆	INTERFACE:	☆☆☆☆
DIALOGUE:	☆☆	AUDIO:	☆☆☆
ANIMATION:	☆☆☆☆	LENGTH:	☆☆☆☆
OVERALL ANALYSIS: ☆☆☆☆			

SYSTEMS

- MS-DOS IBM-PC/Tandy & Compatibles

FEATURES

- A true 3-D Environment!*
- Unparalleled dungeon excitement!*
- Thrilling combat and magic!*
- Automapping!*
- State-of-the-art sound and graphics!*



SCENARIO

Origin's *Ultima Underworld: The Stygian Abyss* is a role-playing/adventure masterpiece! You assume the role of the almighty Avatar, noblest of all heroes, who's sent deep into the finging channels of Britannia's glum underworld. Your objective is to find and rescue the beautiful damsel Arial, who was unjustly kidnapped by the Trolls. As you weave through nearly 25 miles of winding passages on eight separate levels, you'll encounter lugubrious Lizardmen, gargantuan gazers, charring fire elements, poisonous giant rats, winged imps, slimy acid slugs, and the hellbent headless. Barter for necessities with friendly abyss dwellers and they may aid in your

quest. The true 3-D environment is breathtaking, and the interface is very sophisticated, yet simple to use. If you're a diehard adventurer who has never stepped forth into a role-playing arena such as *Ultima Underworld*, you're not only depriving yourself of a new and fantastic realm but also underestimating your capacity for heroism. If you really want to prove your heroism, I command you to enter *The Stygian Abyss!*

WALK-THROUGH

LEVEL 1



Screen from UU2

After shedding some light with the torch found in the nearby sack, search the labyrinth for food, another light source, and a suitable weapon. Then find the red key and the rune bag.

Hint: *Organize inventory in such a manner that you have a backpack for miscellaneous items; your food in a separate sack; and additional sacks for keys, scrolls, etc.*

In order to acquire an extra life, you must find the Silver Sapling shrub. After planting this seed, you'll be resurrected should you encounter an untimely death. Venture through the tunnels in search of Bragit. Talk to him using the following dialogue responses:

☐ 2-1-1-2-1-1-2

Leap over the chasm (at *C* on the map of Level 1) and venture north to reach the Outcasts' area. Use the red key to unlock the door. Speak to Hagbard and Gulik. Hustle to the Silver Sapling Room. The secret door (at *V* on the map of Level 1) is located along the room's east side. Beyond this door is the Shrine and the platform where the Shrine door trigger is located. Save the game. Jump to the trigger platform and push the button. Continue your leaps to the platform leading to the Shrine. Enter the Shrine and read the wall plaques. Talk to the Ankh and chant several Mantras. Exit the Shrine, plug your nose, and dive into the underworld stream. Swim east until you reach a platform. Climb out of the water and locate the gray key (break down the door using a second-hand weapon). Be sure to kill any acid slugs that may get in your way. Once you have the gray key, venture north and peer into the orb. Now it's time to find Drog—his humble abode is only accessible via the underwater canal. After Drog opens the portcullis, find Lanugo and obtain the abhorrent recipe for Rotworm Stew:

- One dead Rotworm
- A bottle of port (Level 2)
- A green mushroom
- A mixing bowl

Search the passages for Vernix. Once you find him, flatter him and you'll gain the grave knowledge of the abyss. Now find Eb—you must get past him to enter the gray goblins' domain. After gaining passage, speak to Retichall, the Queen, using the following responses:

- 1-1

She'll allow you to talk to King Ketchaval. After chatting with the King, locate the jail cell just south of Ketchaval's cubicle. Read the note, then tuck the pole safely in inventory. It has come time, Sir Avatar, to test your fighting skills. You must find, and defeat, the giant spider known in these parts as Navrey Night-Eyes. Then, and only then, can you gather its wondrous spider thread. After slaying the fiend, and getting a handful of giant-spider's thread in inventory, travel back to the gray goblins' area and talk to Jaacar. You'll learn about the noxious privy (at *P* on the map of Level 1) that allows access to Level 2.

LEVEL 2

After descending to the second level, swim south and climb onto the ramp. Search the channels for Brawnclan. After he allows you passage into the mountainfolks' area, enter the Throne Room. Speak to Goldthirst and offer to slay the gazer. Of course, being the impatient Avatar that you are, you realize that there are more important things to do than slay a measly gazer, so you choose to give Goldthirst some gold. In return, he gives you a password (Deco Morono). After drooling over his hoard and defeating inclinations toward theft, it's time to obtain the antique flute. But before you can get the flute, you must seize the key to unlock the door guarding this desperately needed instrument. The key to the Flute Room is hidden in a channel due north of the mine entranceway (at *B* on the map of Level 2). And—wouldn't you know it—a giant spider is guarding the key. Slay the spider and take the key. Before hustling to the Flute Room (at *J* on the map of Level 2), enter the mines and find Shak. From him you'll learn that two of Sir Cabirus's eight talismans still exist: the Shield of Valor and the Sword Caliburn. Unfortunately, the Sword Caliburn has been broken into two pieces and their locations are unknown. After having Shak repair any damaged weapons, leave his domain and obtain the Ancient Flute. Just south of Goldthirst, you'll find the staircase leading to the next level.

Hint: *If you decide to retrieve Ironwit's blueprints, you'll obtain a flask of flying potion. Begin by obtaining the key at K while remaining on the yellow brick road. Get the flask of green flying potion at P. Finally, using the flying potion, get the blueprint and return it to its rightful owner.*

LEVEL 3

Welcome to Level 3, the region of the labyrinth inhabited by the Lizardmen. To enter their domain, locate the wall plaque (while being careful not to touch the poisonous plants) and you'll find the combination to open the door:

❑ Left-Right-Center

With plenty of food rations tucked away in your inventory sack, find the Lizardman called Sseetharee; he's the jailor guarding the human Murgo. Murgo understands the Lizardmen lingo, but he's a mute and can only sign. By offering Sseetharee food, he'll release Murgo (be forewarned, however—this guy's starving).

THE LIZARDMEN TONGUE

<i>bica</i>	hello, goodbye
<i>'click</i>	no
<i>'click-iriass</i>	Sir Cabirus
<i>eppa</i>	visit
<i>isili</i>	me
<i>kri'kla</i>	lurker
<i>ossli</i>	enough
<i>sel'a</i>	give
<i>sor'click</i>	stranger
<i>sorr</i>	enemy
<i>sorra</i>	steal
<i>sseth</i>	yes
<i>sstresh</i>	help
<i>Thepa</i>	lizardmen
<i>thes'click</i>	hate
<i>thesh</i>	like
<i>thit</i>	need
<i>tosa</i>	you
<i>Urgo</i>	Murgo
<i>yeshor'click</i>	friend
<i>yethe</i>	kill
<i>zekka</i>	food

If you're still having trouble understanding the lingo, use the following dialogue responses when conversing with Sseetharee:

❑ 1-4-1-1-1-3-(2)

If you've satisfied Sseetharee's hunger, he'll free Murgo. Talk to Murgo and tell him to steal food no more—later in the game he'll repay you for your kindness.

Dive into the murky water and swim to the northernmost platform (near *L* on the map of Level 3). Enter the first door and walk to the end of the tunnel. After being teleported to another path, find and speak to the pitiable soul Zak using the following responses:

□ 1-2-2-1-1-1-1-1

Grab the scroll, then wander further into the abyss until you find Ishtass (at *I* on the map of Level 3). Agree to find the mortal remains of the Lizardman sage Ossika. To get to the remains, venture east, then north. From atop the bridge, dive into the water and swim south. Climb onto the platform (at *G* on the map of the third level). Take the ragged scroll and the book. Return the scroll to Ishtass and he'll reward you with a sack full of goodies. To obtain the almighty blade of the Sword Caliburn (at *B* on the map of Level 3), you must find the secret door (at *J* on the map of Level 3) that leads to a lever that drains the pond (at *H* on the map of Level 3). When you reach the general area, move the vines to uncover the door. With the mighty blade in inventory, travel to the staircase leading to Level 4.



LEVEL 4

After arriving on the fourth level, seek the halls for the troll, Sethar Strongarm (*S*). After learning that it's Sethar who desires Rotworm Stew, use Lanugo's recipe to whip up a batch of the putrid substance. For tickling Sethar's taste buds, he'll present you with some dragon scales. Now search the bleak halls for the region inhabited by the Knights of the Crux Ansata. Speak to one of the following knights:

- Doris
- Kyle
- Meredith
- Cecil

After being invited to join their knightly order, speak to Sir Dorna Ironfist in a humble tone:

- 1-1-3-1-1-1-2-1-2-2

To test your skills, Sir Dorna will send you on a quest: find and return the Writ of Lorne. The Writ of Lorne is located in the troll's Treasure Room (*T*). To gain entry into this room, give Rawstag a red ruby.

Return to Sir Dorna and a greater task he'll give: find and return a golden plate. This plate is hidden behind a secret door (*W*) deep within a maze on this level. There's more to this task than meets the eye, however:

Rodrick—a knight never before defeated—must be slain by the almighty Avatar. Before attempting to slay Rodrick, talk to Trisch and he'll tell you that a madman, resembling Zak, has stolen the Taper of Sacrifice, one of Sir Cabirus's eight talismans. Find Ree and you'll learn about the Golem located on Level 6.

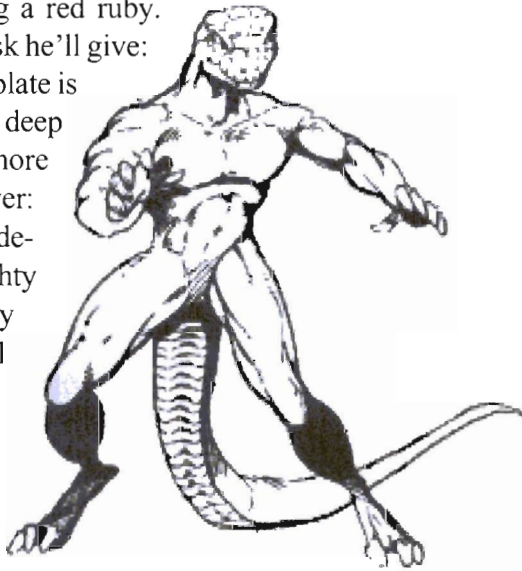

Find the gemwright, Derek, and he'll tell you that he requires a quality gem cutter. Journey to the gravestones (*G*) and observe the color dots—they represent the *left* and *right* levers that open a door deeper in the abyss. Enter the Shrine (*X*). Read the scrolls and chant several Mantras. Are you ready to defeat Rodrick? I hope so, because it's time to acquire the key that's in his possession. Travel to the Cabirus's Hall (*C*). Speak to Biden (*E*), then save the game. If your vitality flask is full, enter the hall and slay Rodrick. Take his key (it opens the door leading to the maze). Weave through the maze (veering south) and open the secret door (*W*). The next door must be opened using the code on the gravestones:

❑ L-R-R-L-L-R

With the gold plate in inventory, return to Dorna and you'll be fully knighted and given the Standard of Honor. Offer Sir Dorna the gold plate and he'll unlock the knight's armory (*P*). Help yourself to some excellent gear, then enter Level 5 via the staircase near Linnet (*L*).

LEVEL 5

Though you may want to dash up to the third level and confront Zak, that would be wasted action. Locate the ghoul named Marrowsuck (*0*). If you give Marrowsuck a piece of spider thread and a handful of dragon scales, he'll manufacture a pair of dragonskin boots. Once you have the lava-retardant boots, find Shanklick (*B*). Talk to him using the following responses:

❑ 1-2-2-1-1

From him you'll receive pertinent clues about the heft of the Sword Caliburn. Now locate Anjor (*A*) and he'll give you a chunk of zanium. The combination to the mine chamber can be obtained from Kneenibble (*K*). He'll demand 10 fish for this information. If you have a fishing pole, find the nearest pool of water and catch his request. The combination to enter the teleport chamber (*Q*) follows:

❑ 7-2-6

ULTIMA UNDERWORLD

Enter the mines and collect a minimum of eighty (80) zanium granites. Then find the sign that leads to the mine's exit. Bring the chunks of zanium to Anjor and he'll reward you with a large gold nugget. It has come time to travel to the third level and question Zak about the Taper of Sacrifice. Barter food for his taper. Now travel to the second level. Give Shak the broken sword and for 20 gold pieces he'll repair it. During the time it takes Shak to repair the sword, slay the gazer and report your defeat to Goldthirst (use a rock hammer to pass the boulders blocking the path to the gazer). Goldthirst will reward you with the Gem Cutter of Coulnes. Present Goldthirst with the gold nugget and he'll give you a magical, jeweled axe. With a minimum of 20 gold pieces tucked away in inventory, pay Shak for his duties and retrieve the Sword Caliburn. Descend to Level 4 and give Derek the gem cutter. Descend to Level 5 and, following Derek's instructions, solve the Ring of Humility puzzle. To do this, enter the Ring Room (*E*), then stay as far away from the middle of the room as possible.

Hint: *Remain as close to the outer walls as possible.*

Now click on the levers in the following order:

- Northwest
- Southeast
- Northeast
- Southwest

Walk to the center of the room and take the Ring of Humility. Exit the Ring Room and find Eyesnack (*B*). Have him teach you the repertoire *Mardin's Song of Wonder* on the ancient flute.

LEVEL 6

Locate the mage, Dr. Owl (*A*). Since you helped Murgo earlier in the game, Dr. Owl will give you pertinent information about the Wine of Compassion (*W*). If you ask, Dr. Owl will give you a *Flam* rune. Travel to the checkerboard room (east of the meeting hall of the Academy) and lift the southeastern floor tile. With

the Wine of Compassion safely tucked away in inventory, find the mage, Bronus (B). He'll give you a book of magic that you must return to Morlock (M).

Hint: *Don't open the magic book or it will explode.*

After Morlock receives his spell book, reply using the following response:

. . . *I slew no such beast*

Now it's time to gain the Book of Honesty. Locate, and open, the secret door at V. Jump over the chasm and retrieve the book at E. Find Nilpont and learn about the Golem. Slay the Golem (G) and you'll gain possession of the Shield of Valor. Now seek the mage Gralwart (H). He'll help you locate the most powerful rune, Vas. To get this rune, travel to the Banner Room (U). Walk into the wall between the banners and you'll teleport to The Pit (P). Collect all the emeralds, then jump *twice* to the upper level of The Pit. Visit the four corners and toss an emerald on each pedestal. Jump to the lower section of The Pit and push the gray button. Get the Vas stone, then push the orange button to exit The Pit. Find the mage named Fyrgen (F). He'll tell you about mystical dreams caused by sniffing incense. Before attempting this procedure, talk to the mage, Louvnon (L). After talking to both Louvnon and Fyrgen, locate three chunks of incense at (J). Using a torch, light the first chunk and use it. Repeat this procedure with the other two chunks of incense and you'll inherit the *INSAHN* mantra. Chant this mantra at several Shrines (on several different levels) and you'll be guided to the Cup of Wonder (at C on the map of Level 3).

Hint: *If you wish, you may head directly to Level 3.*

After swimming to the room where the Cup of Wonder is hidden, play Mardin's Song of Wonder (using the ancient flute) and you'll find the chalice. Using the

ULTIMA UNDERWORLD

keyboard, type in the following notes of the lively tune:

❑ 3-5-4-2-3-7-8-7-5

LEVEL 7

If you have a rock hammer and all eight of the following talismans, you can descend to Level 7:

- ❑ Sword of Justice
- ❑ Ring of Humility
- ❑ Cup of Wonder
- ❑ Shield of Valor
- ❑ Wine of Compassion
- ❑ Standard of Honor
- ❑ Taper of Sacrifice
- ❑ Book of Honesty



Talk to the injured warrior, Cardon, and you'll learn of the medallion located at *R*. Retrieve the medallion (by leaping over a chasm) and use it to pass the goblin guards. Find and talk to Naruto (*N*). Naruto will tell you about a crucial key. Go north, then east. Slay the giant spider and take the key. Travel to Tyball's prison (*P*). Once trapped, you can bribe the goblin to open the west portcullis by offering him food, gold, and the flute. Talk to the prisoners, beginning with Fintor (*F*). He'll tell you about the mines and the material that Tyball's orb is made of. After talking to Kallistan (*L*), give him the following password:

❑ DECO MORONO

He'll give you a crystal splinter that'll allow you to enter the tombs. To get out of the prison, talk to the prisoner named Dantes (*D*). He'll gladly give you a clue about the secret passageway located in his cell. Use this passage. Travel east,

jump over two chasms, and follow the hallway around the jail. Open the secret door near the north bridge (near tapestry) and follow the tunnel until it ends at another secret door. Open the secret door and continue south. Locate the secret tomb entrance that can only be opened with the crystal splinter in inventory (to open the secret door, just walk into it). Enter the first tomb on the left. Locate the secret door along the east wall. Follow the path until you find another secret door on the north wall. Weave your way through the hallway until you reach a stream of lava. Leap across the lava and use the key to unlock the upper door. Use the staircase to reach Level 8, then the other staircase to enter the Treasury (*H*). Talk to the imp and he'll allow you to take the magic crown (the correct crown contains a tiny white jewel). When this crown is worn, you'll see the yellow brick road leading to Tyball. Travel back to the seventh level and use the staircase at *M* to enter the mines. Gather several orb rocks. Exit the mines and travel to the southeast portion of the map. On your way, find the key beneath a skull at *K*.

THE MAZE OF TYBALL

After breaking down two doors and crossing a bridge, you should be at the entrance to Tyball's maze. Place the magic crown on the Avatar's head and save the game. Now follow the yellow brick road until it ends at a door. Open the door and prepare to battle Tyball. First, smash Tyball's Orb using the orb rocks you collected in the mines. This will allow you to use magic on the seventh level. Speak to Tyball and learn of his scheme. Using all your might, kill Tyball and take his keys. Using Tyball's keys, you can free Ariel. By now, your vitality flask must be nearing a level of concern. Replenish your strength by eating some food and taking a nap. While you sleep, Garamon will visit your dreams and ask you to properly bury his bones (this can be done later in the game).

THE TRI-KEY

Travel back to Tyball's prison (*P*) and use Tyball's keys to gain access to the most secure cells. Talk to the prisoners beginning with Smonden (*I*). After he gives you a key, talk to Gurstang (*O*) and you'll be given a password (*Folanae*). This password gives you access to the Key of Truth. Talk to Bolinard (*B*) and obtain a crude drawing of the fighter Tom. Locate the staircase (northwest quadrant of the map) leading directly to Level 3. Obtain the Key of Courage (at *K* on the map of Level 3). After returning Tom's picture to Judy (at *J* on the map of Level 5),

ULTIMA UNDERWORLD

take the Key of Love. Descend to Level 6 and give the password to Illomo (at *I* on the map of Level 6). In the library (*Q*), find the book entitled:

Folanae Fanlo

Take this book to a shrine and chant the second word in the book's title. When the Key of Truth appears, grab it. Combine the following keys to create the Key of Infinity:

- Key of Courage
- Key of Love
- Key of Truth

LEVEL 8

Find Carasso (*C*); he'll provide you with a key and the location of the remains of Garamon (the key opens the way to a chamber known as the Chamber of Virtue). After gathering Garamon's remains, travel to Level 5 and bury them at Garamon's grave (at *N* on the map of Level 5). When the spirit of Garamon appears, mention *volcano* and *talismans*. The spirit of Garamon will give you a suggestion on how to defeat the Slasher of Veils. Now it's time to descend to Level 8. Use the Key of Infinity to gain access to the Chamber of Virtue (*D*). Throw all eight talismans into the mouth of the volcano, then hustle down the green path and exit through the green Moongate to safety.

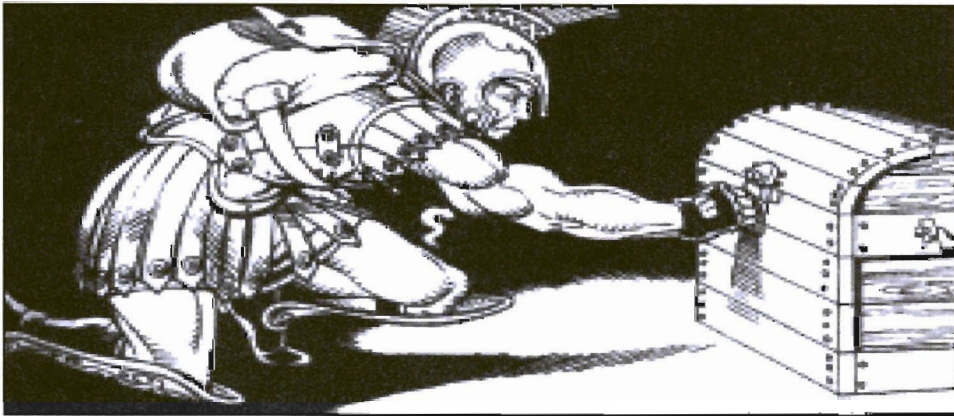

SPELLS

<input type="checkbox"/> Armageddon	VKC
<input type="checkbox"/> Curse	AS
<input type="checkbox"/> Jump	UP
<input type="checkbox"/> Monster Summoning	KM
<input type="checkbox"/> Sheet Lightning	VOG
<input type="checkbox"/> Smite Undead	ACM
<input type="checkbox"/> Thicker Skin	IS
<input type="checkbox"/> Walk on Water	YP

MANTRAS

<input type="checkbox"/> Acrobat	FAL
<input type="checkbox"/> Appraise	HUNN
<input type="checkbox"/> Attack	RA
<input type="checkbox"/> Attack Skills	SUMM RA
<input type="checkbox"/> Axe	GAR
<input type="checkbox"/> Casting	SOL
<input type="checkbox"/> Charm	UN
<input type="checkbox"/> Cup of Wonder	INSAHN
<input type="checkbox"/> Defense	ANRA
<input type="checkbox"/> Key of Truth	FANLO
<input type="checkbox"/> Lore	LAHN
<input type="checkbox"/> Mace	KOH
<input type="checkbox"/> Magic Skills	MU AHM
<input type="checkbox"/> Mana	IMU
<input type="checkbox"/> Missile	FAHM
<input type="checkbox"/> Pick Lock	AAM
<input type="checkbox"/> Repair	LON
<input type="checkbox"/> Search	LU
<input type="checkbox"/> Sneak	MUL
<input type="checkbox"/> Swimming	ONO
<input type="checkbox"/> Sword	AMO
<input type="checkbox"/> Track	SAHF
<input type="checkbox"/> Traps	ROMM
<input type="checkbox"/> Unarmed	ORA

MAPS

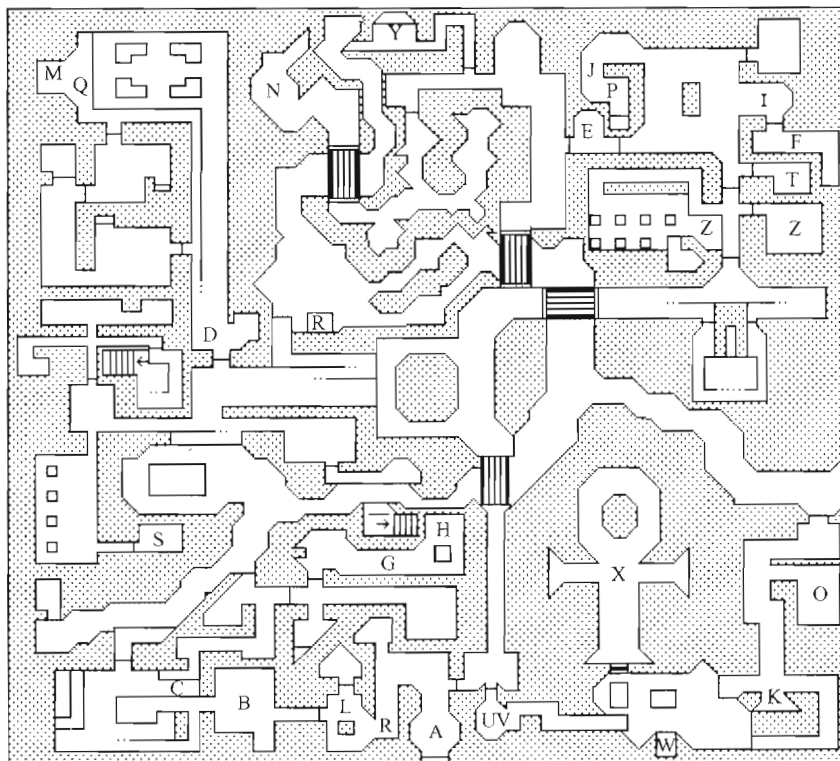

LEVEL ONE

A= Start	N= Navrey Night-Eyes
B= Bragit	O= Orb
C= Chasm	P= Privy
D= Drog	Q= Lanugo
E= Eb	R= Runestones
F= Ketchaval	S= Spell Scroll
G= Gulik	T= Prison
H= Hagbard	U= Silver Sapling
I= Retchall	V= Shrine Door
J= Jaacar	W= Shrine Door Trigger
K= Key	X= Shrine
L= Loot	Y= Healing Fountain
M= Vernix	Z= Platforms & Dials

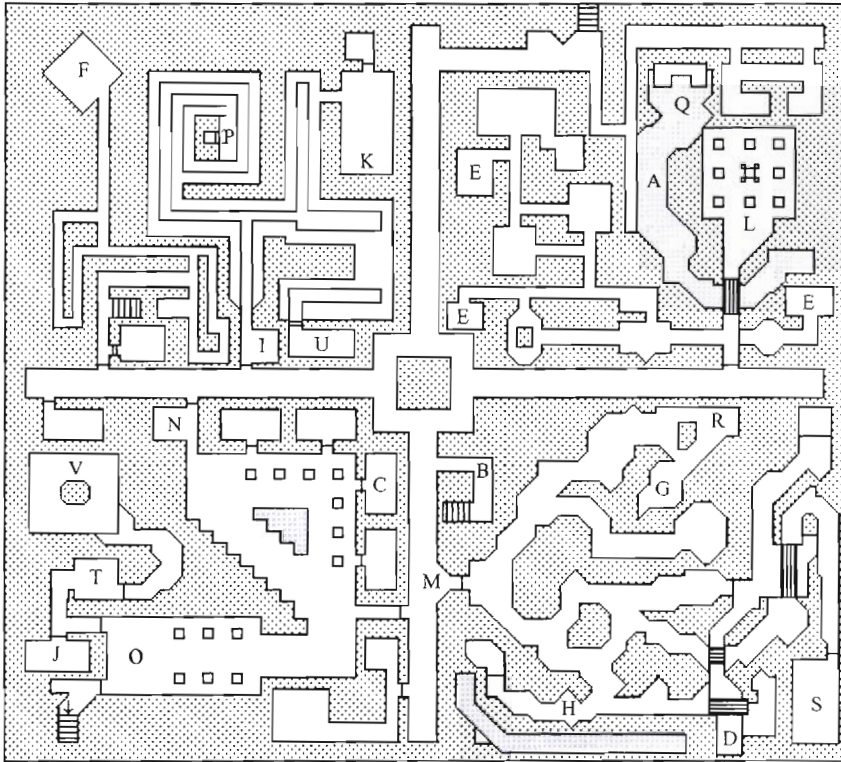

LEVEL TWO

- | | |
|-----------------------|---------------------|
| A= Privy Outlet | N= Brawnclan |
| B= Spider & Key | O= Goldthirst |
| C= Corby | P= Flying Potion |
| D= Drain (to level 3) | Q= Healing Fountain |
| E= Mantra Scroll | R= Runestones |
| F= Shrine | S= Shak |
| G= Gazer | T= Steeltoe |
| H= Hewstone | |
| I= Ironwit | |
| J= Antique Flute | |
| K= Key | |
| L= Loot | |
| M= Mine Entry | |

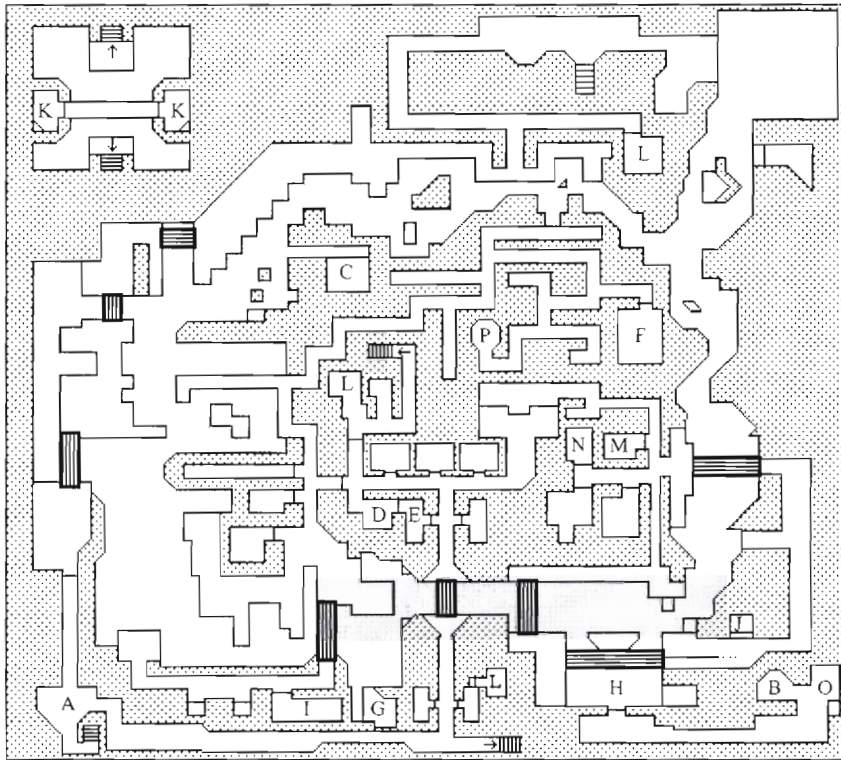

LEVEL THREE

- A= Plaque
- B= Blade of Caliburn
- C= Cup of Wonder
- D= Sseetharee
- E= Jail
- F= Zak
- G= Ossika's Bones
- H= Pond
- I= Ishtass
- J= Lever
- K= Keys
- L= Loot
- M= Mantra Scroll
- N= Spell Scroll
- O= Shrine
- P= Runestones

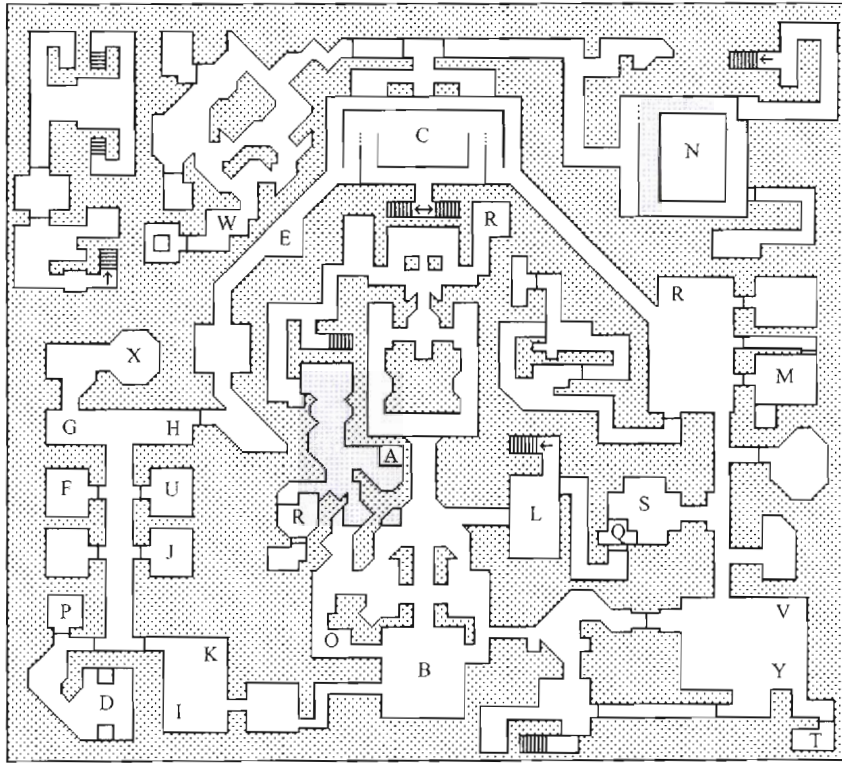

LEVEL FOUR

- | | |
|-----------------------------|---------------------|
| A= Alcove | N= Dials Room |
| B= Battle Site | O= Oradinar |
| C= Cabirus's Hall (Rodrick) | P= Knights' Armory |
| D= Doma Ironfist | Q= Loot |
| E= Biden | R= Runestones |
| F= Feznor | S= Sethar |
| G= Gravestones | T= Troll's Treasure |
| H= Ree | U= Trisch |
| I= Doris | V= Lakshi |
| J= Derek | W= Secret Door |
| K= Kyle | X= Shrine |
| L= Linnet | Y= Rawstag |
| M= Lever Room | |

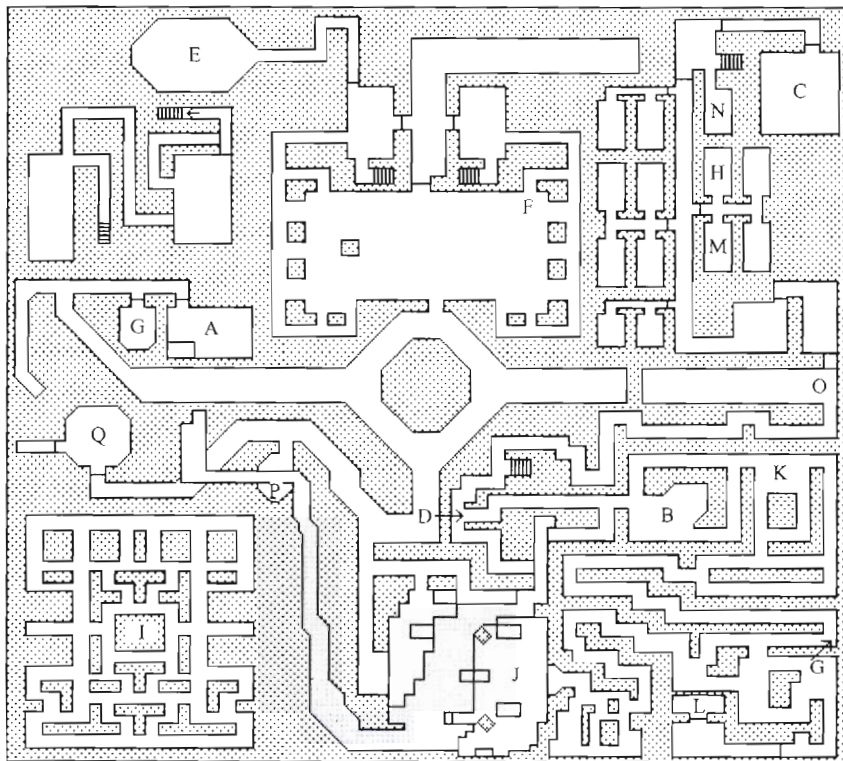

LEVEL FIVE

- A= Anjor & Shrine
- B= Shanklick & Eyesnack
- C= Cabirus's Grave
- D= Marrowsuck
- E= Ring of Humility
- F= Bard's Remains
- G= Ghost with Loot
- H= Haft of Caliburn
- I= Mines
- J= Judy
- K= Kneeknibble
- L= Loot
- M= Mantra Scroll
- N= Garamon's Grave
- O= Secret Door
- P= Spell Scroll
- Q= Teleport Chamber

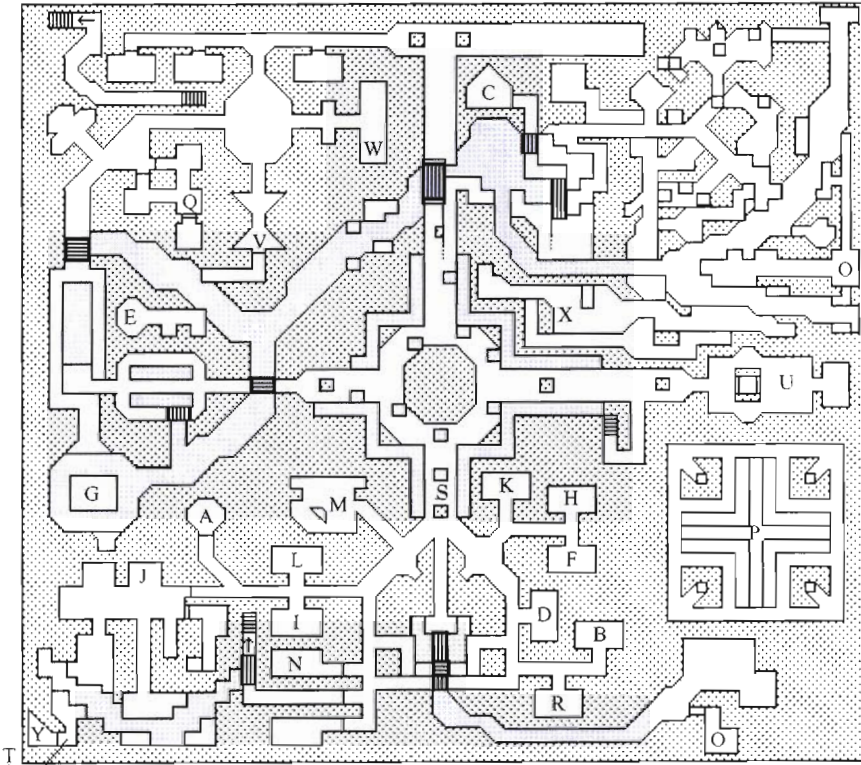

LEVEL SIX

- | | |
|--------------------|-----------------------|
| A= Dr. Owl | N= Nilpont |
| B= Bronus | O= Loot |
| C= Book | P= The Pit |
| D= Delanrey | Q= Library |
| E= Book of Honesty | R= Ranthru |
| F= Fyrgen | S= Shenilor |
| G= Golem | T= Talking Door |
| H= Gralwart | U= Banners |
| I= Illomo | V= Secret Door |
| J= Incense | W= Wine of Compassion |
| K= Dominus | X= Mantra Scroll |
| L= Louvnon | Y= Runestones |
| M= Morlock | |

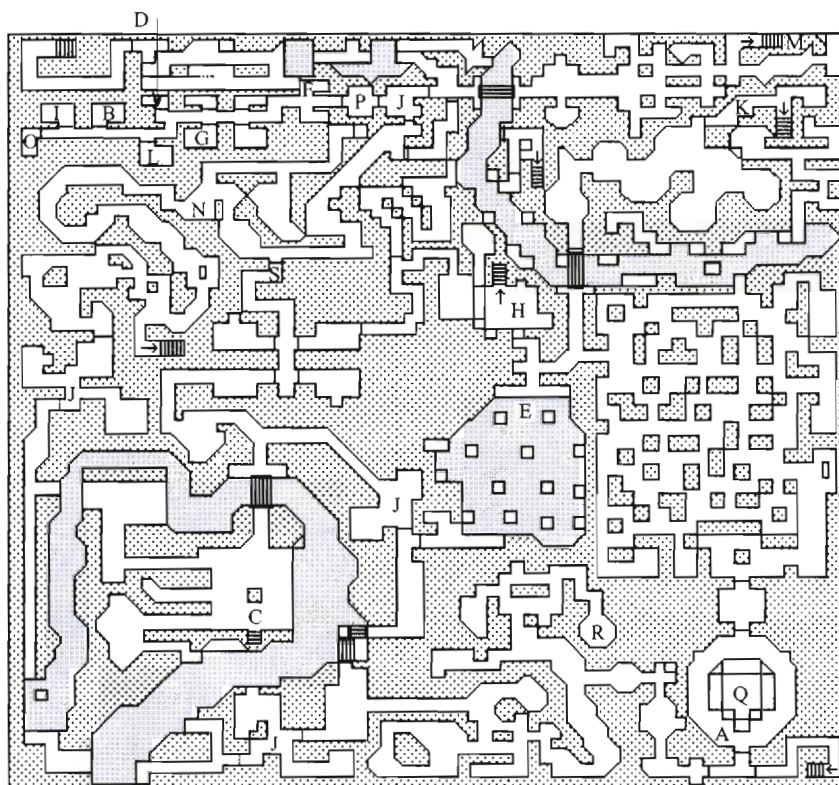

LEVEL SEVEN

- | | |
|-----------------------|----------------------|
| A= Arial | N= Naruto |
| B= Bolinard | O= Gurstang |
| C= Cardon | P= Tyball's Prison |
| D= Dantes | Q= Tyball |
| E= Door | R= Medallion |
| F= Fintor | S= Secret Shard Door |
| G= Griffle | |
| H= Treasury | |
| I= Smonden | |
| J= Tyball's Guards | |
| K= Key to Door at (E) | |
| L= Kallistan | |
| M= Mine Entrance | |

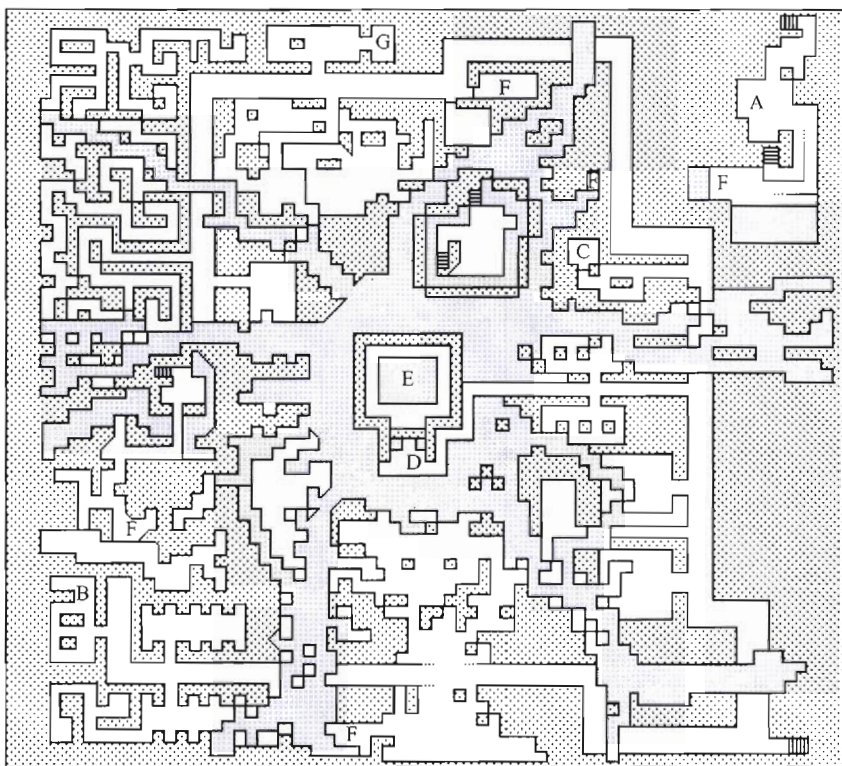

LEVEL EIGHT

- A= Vein of Ore
- B= Bones
- C= Caraaso
- D= Chamber of Virtue
- E= Volcano
- F= Magic Item
- G= Shrine

SECTION 2

ULTIMA UNDERWORLD 2

GRAPHICS:	☆☆☆☆	STORY LINE:	☆☆☆
ARCADE:	☆☆☆	INTERFACE:	☆☆☆☆
DIALOGUE:	☆☆	AUDIO:	☆☆☆
ANIMATION:	☆☆☆☆	LENGTH:	☆☆☆☆
OVERALL ANALYSIS: ☆☆☆☆			

SYSTEMS

- MS-DOS IBM-PC/Tandy & Compatibles

FEATURES

- Eight new worlds to explore—from fantastic castles to ice caverns, towers and alien realms.*
- An expanded, more panoramic 3-D view window—30 percent larger than before!*
- Larger, higher-resolution creature graphics with additional frames of animation for smoother, more lifelike movement.*
- New trap and puzzle types featuring animated, multi-level obstacles, moving terrain, pressure-sensitive triggers, and more!*
- Detailed, close-up portraits of scores of characters whose attitudes and actions vary based on your decisions.*
- New magical spells of unimaginable power—attack around corners with *Deadly Seeker*; bowl your enemies over with *Shockwave*; create deadly artifacts with *Poison Weapon*!*
- Treacherous new terrain features with slippery ice and dangerous currents designed to challenge even the most experienced dungeon-delver.*



SCENARIO

To commemorate the rescue of Ariel a year ago, you, the almighty Avatar, have been invited to celebrate in Lord British's castle. During the revelry, the Guardian strikes again, encasing the entire castle in a gigantic blackrock gem. The Guardian's ultimatum: proclaim him ruler or starve while his sycophants conquer the tract. *Ultima Underworld II: Labyrinth of Worlds* by Origin boasts a new viewing screen that's 30 percent larger than the one used in its predecessor. The levels of the stygian abyss have grown into entire magical kingdoms, each with multiple levels. And the kingdom dwellers have been created in higher-resolution graphics with added frames to enhance animation. (A note to those of you who have purchased an early copy of *UU2*—you may need the patch disk to solve two major problems: servant/plot hang; sleeping with the moonstone on your cursor, dreaming the Ethereal Void, and dropping the stone.) Should you encounter these quirks, contact Customer Service and have them mail you the patch disk containing three zip files: `uw2.exe`, `data\cnv.arc`, and `data\strings.pak`. After the patch is installed, you should be able to continue the game without having to start over.

WALK-THROUGH

BRITANNIA: LEVEL 1

Welcome back, almighty Avatar. Begin this quest by building inventory—many useful items can be found in your room. Grab everything you think you'll need. The north wall hides a secret door. Enter the secret room and grab the rune bag and all the runes.

***Hint:** Organize inventory in such a manner that you have a backpack for miscellaneous items; your food in a separate sack; and additional sacks for keys, scrolls, etc.*

Search the castle for the Throne Room (use the game's automap if you have trouble locating it). Speak to Lord British. Find Nystul's room. In the closet you'll find Nystul's lab and some runes and potions. Be sure to talk to Dupre; he'll give you the key to the sewers. Now return to your quarters and walk through the secret doorway. After pulling the wall lever, walk north through the doorway, then head west (left). Use the key that Dupre gave you to unlock the closed door. Descend the stairs to Level 3.

SEWERS: LEVEL 3

Welcome to the slimy sewers. Slay any and all vermin you happen to encounter (just stay away from the fearless headless living in the northern passages). Search the sewers for a man named Fissif. Dispatch him to jail after reminding him that the sewers are no place for a man to live. Now head north to find the room with the moving floor. Enter the north (left) portcullis. Pull the chain that toggles the south portcullis. Weave south through the passages to find the hole leading to Level 4.



SEWERS: LEVEL 4

Plenty of good stuff can be had here, so keep a watchful eye. Swim across the lake to the center isle. Locate the ladder that descends to Level 5.

SEWERS: LEVEL 5

This passage will lead you to the blackrock gem. Explore this level (the waterfalls hide many secret passages), then return to the blackrock gem. Notice the facet (on the gem) that's aglow. Walk into it and you'll be transported to another world.

PRISON TOWER: LEVEL 1

After teleporting from Level 5, you'll land in the basement of the prison tower. Empty the first barrel and take the supply voucher. Clamber up the staircase.

PRISON TOWER: LEVEL 2

When the guard questions your presence, show him the voucher. Then walk through the portcullis (the security doors are designed so that only one door may open at a time). Travel to Level 4.

PRISON TOWER: LEVEL 4

Talk to Janar. Walk into the kitchen area and talk to Felix. Agree to kill Freemis and he'll offer you a cornucopia. Go to Level 5.

PRISON TOWER: LEVEL 5

Locate the armory. When you meet the goblin who's having trouble concocting the fraznium gauntlets, tell him to coat the regular gauntlets with the fraznium. This will make him very happy—and since he's in such a cheerful mode, ask to borrow a pair of gauntlets. Wear the gauntlets and proceed to Level 6.

PRISON TOWER: LEVEL 6

Find the Captain's Quarters. When he greets you, don't reveal your true identity. Offer to question Bishop.

Hint: Remember the randomly generated code word: It's extremely important.

Ask the guard-captain for his keys—tell him that you're following the Guardian's orders. He'll give you another code word you must relate to Janar (to obtain keys). After he grants you a spare pair of gauntlets, return to Level 4.

PRISON TOWER: LEVEL 4, VISIT 2

Obtain the keys from Janar, then return to Level 6.

PRISON TOWER: LEVEL 6, VISIT 2

Open the locked door and you'll find Garg. Be cordial to him and he'll slay the Goblins. Enter the Captain's Quarters and get the small black gem. Search these parts for useful inventory items, then ascend to Level 8.

PRISON TOWER: LEVEL 8

Open the first cell to your left. Talk to Milenus. Locate Bishop behind the force field. Talk to him, then offer him the spare pair of frazanium gauntlets. Return to Level 4.

PRISON TOWER: LEVEL 4, VISIT 3

Track down Felix and he'll give you a spell box. Each time the box is opened, it will provide you with food rations. Return to the basement and walk through the blackrock wall. Return to Castle Britannia. Talk to everyone you meet, then take a nap. After revitalizing your mana and vitality flasks, request that Nystul treat the gem you have in inventory. Once that's been completed, Nystul will instruct you to use the small gem on the large blackrock gem. Return to the large blackrock gem (in sewers) and use the small gem on the large one: This will cause another facet to glow. Walk into the gem until you teleport to Killorn Keep.

KILLORN KEEP: LEVEL 1

Meander around the halls in search of the mess hall. Speak to Lobar, Ogri, and Kintara. Get the fire-resistant boots from Kintara. Now locate Mystell. After answering her questions, give her the information you learned from Kintara. Also, pretend to do her dirty work. Locate and become friends with Altara. Mention the name *Bishop* and she'll offer you a dagger. Leave Killorn Keep and travel to Level four of Britannia.

BRITANNIA: LEVEL 4

To the southwest you'll encounter a bridge—swim beneath it, then climb up the staircase. Jump over the bench, climb the staircase, and follow the path into the lava. Enter the lava room and kill the imp using Altara's dagger. Travel back to the cavern and find the spider den. Snatch a spider egg, then return to the portal gem. Walk into the gem until you find the ice caves.

ICE CAVES: LEVEL 1

Travel northwest until you find the remains of a party of explorers. From there, walk south until you find a descending staircase. In the passage just east of the staircase are the remains of a fallen champion. Return to the stairs and descend to Level 2.

**ICE CAVES: LEVEL 2**

After emerging from the staircase, take the first dirt passage on your right. Speak to the mindless Mopko, then get some rest. When you awake, walk southwest until you reach a small strip of dirt. Just beyond the dirt is a slick patch of ice. On the far end of the ice is the small black gem you seek. There are two ways to get the gem: grab it as you slide by, or use your bedroll to sleep—when you awake,

ULTIMA UNDERWORLD II

you'll have better control of your direction on the slippery ice patch. Once you have the gem, return to Mopko, then walk due east to reach Anodunos Dam. Ascend the staircase.

ICE CAVES: LEVEL 3

After killing the ice golem, take his key. Open the door and walk across the bridge. Move the switch and the lever to reveal another passage. Venture along this passageway until you reach the river. Cross the river, then jump over the chasm. You should now be at the controls to the maze. Make sure the switch, the lever, and the chain are in the up position. Also, the button must be set in the out position. Now you can walk through the force field. Follow the maze until you find a key. Return to the maze controls. Pull the lever and the switch in a downward motion. Push the button. Walk through the force field and unlock the door. Pull the chain, then return to where you killed the ice golem. Descend the staircase.

ICE CAVES: LEVEL 4

Locate Anodunos and will find Bernice, the floating ghost. After conversing with her, head northwest and you'll find a set of stairs leading to Level 5.

ICE CAVES: LEVEL 5

After ascending to Level 5, cross the bridge and locate Alorik's lab. There's a hidden switch on the east wall that activates a secret door. Now it's time to head back to Castle Britannia.

BACK TO BRITANNIA

On your return to Britannia, you'll learn that Lady Tory has been murdered. Talk to everyone and be sure to have Nystul treat the gem you took from the ice caves. Now get some rest. After your nap, return to the blackrock gem and use the small gem on the big one. Walk into the gem until you find Talorus.

TALORUS: LEVEL 1

After you arrive at Talorus, locate the Historian: He'll tell you about their world. Walk west to find Futurian. Take the information crystal, numbered *MY4*, from

the chamber behind the Futurian. Find the Bliy Skup Chamber. Kill the Bliy Skup Ductosnore. Now find the room containing the slick purple hole. Jump into the hole and you'll descend to Level 2.

TALORUS: LEVEL 2

Locate the large lava room. Then walk north and you'll find the information crystal (located on the waste disposal ramp) that the Futurian told you about. Travel south and locate the room with the Vorz Ductosnore. Take the Delgnizator from the far wall, then return to the Bliy Skup Chamber. Place the *EOY* crystal in the purple hopper. Place the *MY4* crystal in the yellow hopper. Place the Delgnizator on the center blue circle. Pull the chain located in the corner of the room. Leave this room and find the amethyst rod (it's located in the room with flashing floor squares). Now return to the Historian and he'll transport you to the small blackrock gem. Travel back to the large blackrock gem, then walk into it to reach Killorn Keep.

KILLORN KEEP: LEVEL 1

Find Altara and give her the black pearl, the egg shell, and the amethyst rod. In return, she'll give you a scepter that you must tap on the ground in the places that the Guardian has shown his power by performing major magic. Now travel to the kitchen and find the stairs leading to the basement.

KILLORN KEEP: LEVEL 2

Locate the flowery plants. Eat one of them, then sleep: The plant will cause you to dream of the Shrine of Spirituality. Find the blackrock gem and throw it through the pillars. When you awake, search all the rooms until you find a secret door. Beyond this secret door is a passage that leads to a magical trap. To disarm the trap, throw the candles. Step on the red marble floor and slay the headless. Grab the small blackrock gem and return to Castle Britannia. Have Nystul treat the gems, then return to the portal gem and use the small gems on the big gem. Walk into the portal gem until you find the Scintillus Academy.

SCINTILLUS ACADEMY: LEVEL 1

Open the secret door and talk to the reluctant sole, Elster. Enter the test area and

ULTIMA UNDERWORLD II

take the gold coffer. Place the coffer on the floor's center pressure plate; this will open the right portcullis. Follow this passage until you're teleported to the next stage of the test.

SCINTILLUS ACADEMY: LEVEL 2

Slide into the river and it will take you to a stone area. Climb the stone walkway. Slide northeast and find the wall containing a button. After depressing the button, return to the stone area and slide north to the portcullis. Walk through the portcullis and slide to the end of the cavern to reach the final gate. Cross the oscillating columns to reach an unseen door.

SCINTILLUS ACADEMY: LEVEL 3

Pick up the wand from the floor. Jump north to the middle pillar. Jump on the west pillar. Use the wand on the button located on the wall. Jump two pillars east. Use the wand on the button. Now jump north, north, west, and north. Then walk into the teleporter.

SCINTILLUS ACADEMY: LEVEL 4

The next section of the test can be solved by finding the two keys located in the northwest and southwest corners of the maze. The maze's exit is located in the northeast corner of the room.

SCINTILLUS ACADEMY: LEVEL 5

First locate the pole. Then move the three switches to the up position using the pole (don't get too close to the switches or you'll change the position of the other switches). When the switches are all in the up position, the south door will open. After passing through the doorway, jump over the pit and get the key. Return to the main room and open the north door. Use the key on the portcullis.

SCINTILLUS ACADEMY: LEVEL 6

Step on the yellow plates, then get the key from the center of the room. This key unlocks the northwest door. Walk through the northwest doorway and refer to the map on the following page:

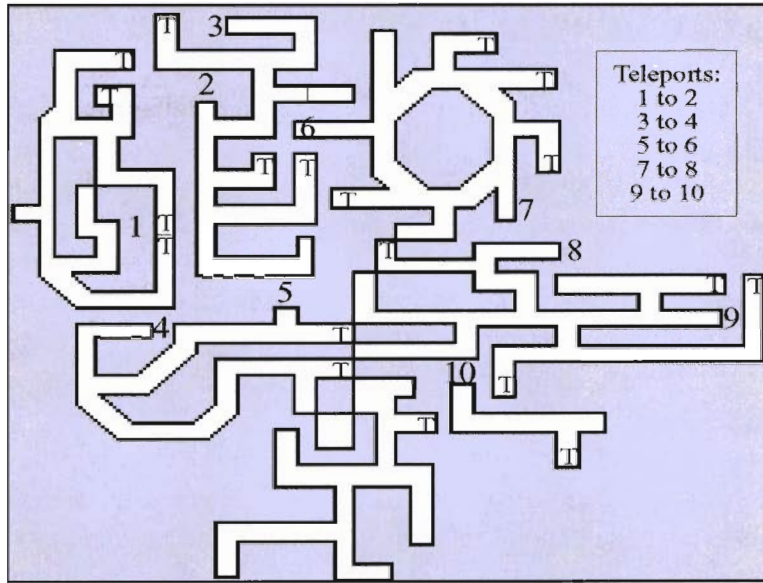

SCINTILLUS ACADEMY: LEVEL 7

Dive into the murky water and swim to the alcove located along the north wall. Get the key. Return to the entrance of Level 7, then refer to the following map:

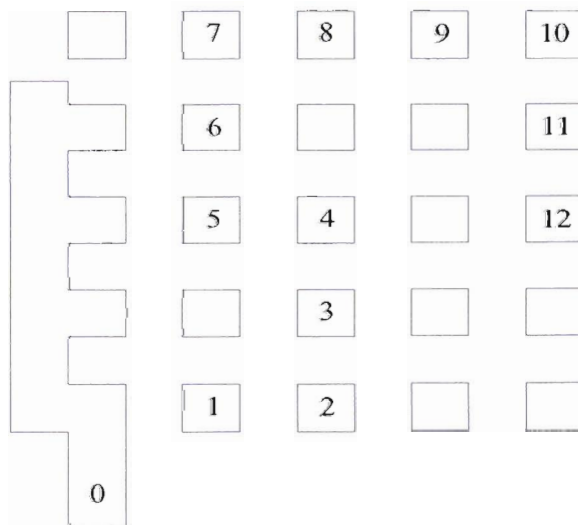

SCINTILLUS ACADEMY: LEVEL 8

Welcome to the final stage of the test. To solve this puzzle, number the rooms in a clockwise manner, beginning with the room containing a red floor:

□ 1: 3 / 2: 5 / 3: 2 / 4: 9

This brings you to the end of the test. Now find the room with the pentagram. Get the gem, then tap Altara's scepter on the floor. Search the other rooms to find the key (hidden behind a bed) that unlocks the vault.

SCINTILLUS ACADEMY: SECURE VAULT

Use the key you found on Level 8 to unlock the secure vault. Use a magic arrow or some other means to disturb the Rune of Stasis from a safe distance. Next use telekinesis to push the button. Enter the water maze and locate the switch that toggles the door. After entering through the first doorway, you'll come across another door. To open this door, walk left (through the illusionary walls) until you come to a switch. Flip the switch and return to the second door on the ledge of three pits. You can either fly over the pits or jump into the pit. If you decide to jump into the pit, walk through the red moongate and you'll end up in a fiery area. You'll need to pull the chain behind the left door and retrieve the key from behind the right door: This will get you into the middle door. Behind one of the doors is the moongate. This moongate will transport you to a pool. Follow the path veering left. When the path veers right, keep going straight while ignoring the walls. This will take you to the outer vault. Open the chest and get the treasure. Locate the other fake wall leading to the inner vault and walk through the force field. Search the floor and take the treasure containing a *Vas* rune, a *Tym* rune, and an axe of fire doom. Make your way back to the portal gem and teleport to the Pits of Carnage.

PITS OF CARNAGE: LEVEL 1

Welcome to the Pits of Carnage. If you earn Dorstag's respect in the arenas, he'll agree to fight you one-on-one. Otherwise you'll have to fight all of his friends (gulp!). If you don't want to fight him, you may descend to Level 3.

PITS OF CARNAGE: LEVEL 3

Find the troll, Blog. If you let him win several games of Rock, he'll help you obtain the gem. Demand the gem from Dorstag.

PITS OF CARNAGE: LEVEL 1, VISIT 2

Being the almighty Avatar, you must find and kill Zaria. Once this has been done, get her Bastik Oil. Now find the room to the north and use Altara's scepter. Return to Castle Britannia. Your next goal is to use Altara's scepter on the four worlds you've already visited. Go to the top level of the Prison Tower and use the scepter in Bishop's cell. Find the key in the basement of Killorn Keep, then travel to the barracks. Find the secret door in the southeast corner of the room. Defeat the guard. Use the key on the door and tap the scepter on the floor. Travel to Talorus and use the scepter in the Bliy Skup Chamber. Find the Anodunos (in ice caves). Enter the fountain and use the scepter. Also, while you're in the ice caves, go to the second level and find the filanium mud flats. Throw the Bastil Oil in the mud, then walk in the mud. Return to the portal gem and find the Ethereal Void.

ETHEREAL VOID

***Hint:** You must have a flask of iron flesh potion, or be of a high enough circle to cast iron flesh, to proceed.*

The Ethreal Void consists of the Shrine of Spirituality and dozens of glowing paths. On the paths are moongates that transport you to different places in the Ethreal Void. To complete the final goal in the Void you must complete four tasks: the purple plane, the red plane, the blue plane, and the yellow plane. You may complete them in any order. After completing the tasks in a plane, you'll be dropped onto a pyramid composed of large cubes. When you step on a cube it will change color. You must step on all the cubes to change the pyramid into a specific color—and you must do this for each of the four color planes. After changing the pyramid to the first chosen color of a plane, you must walk through the white moongate.

ULTIMA UNDERWORLD II

BLUE PLANE

Follow the blue path until you reach the checkerboard area. Here you'll meet Prinx. And guess what? This goon wants some eyeballs (eyeballs can be obtained by slaying a brain creature). Follow the undulating bridge. Walk to the far side of the path and leap to the jump circle. Once you pass through the golden moongate, turn the pyramid blue and walk through the white moongate.

PURPLE PLANE

Follow the purple path until you enter the purple zone. Here you'll meet Blog. Run toward the frictionless ramp that takes you to a purple stream flowing uphill. Follow the arrows and use the jump circles to leap to the frictionless slide (this will take you past the Guardian). Follow the right wall. After killing the stickmen, you'll find the golden moongate. Turn the pyramid purple. But before entering the white moongate, walk to the top of the black path and you'll find a purple moongate. Enter this moongate and you'll find a Djinn bottle containing a trapped air-daemon. Enter the white moongate.

YELLOW PLANE

At the start of the yellow maze you'll see an orb. Gaze into the orb and you'll see the maze's final destination. After entering the golden moongate, turn the entire pyramid yellow. Walk through the white moongate.

RED PLANE

Follow the red path until you reach a moongate. Before entering the moongate, if your magic spells are plentiful cast the flameproof spell. Walk through moongate and locate the fiery room. Now travel through the skull-lined doorway and into the moongate behind the destroyer-daemon. Continue through the tunnel laced with daemons until you reach the third section (the swamp). No need to kill the despoilers or haunts—they aren't hostile. Avoid the lava as you approach the golden moongate. Turn the pyramid red, then enter the white moongate. After successfully turning the pyramid to all four colors, it will fade to orange. Turn the pyramid completely orange and a golden moongate will appear. Enter the moongate and use Altara's scepter. Get the blackrock gem. The white moongate will lead you to the Sigil of Binding.

SIGIL OF BINDING

After placing the Djinn bottle in the pentagram, smash it to smithereens and you'll receive the air-daemon. Return to the portal gem and kill the soldiers. Walk into the gem and teleport to Killorn Keep. Find the barracks and Mors Gotha. Steal her spell book and return to Britannia. Give the spell book to Nystul and have him treat the gem. Return to the portal gem and use the small gem on the big gem. Walk into the gem and find the Tomb of Praecor Loth.

THE TOMB OF PRAECOR LOTH: LEVEL 1

Level one consists of a hub with eight spokes: a piece of the map lies at the end of each spoke. At the end of the northeast spoke is a secret door. Find it and you'll find one of the map pieces. In the east spoke is a fire elemental that has a map piece in his possession. Kill the nearly immortal elemental to obtain the map piece. In the southeast spoke is a pool of water with three platforms and a portcullis. To trigger the portcullis, place a heavy weight on the pressure plate of the southwest platform. In the south spoke is the Honor Guard—just sneak past them and grab the map piece. In the southwest spoke is a panel of switches—you need to set the switches in the down position. Labeling the switches from one to five, the answer is:

❑ 5-4-3-1-2

Go to the western spoke and kill the metal golem to get the map piece. The northwestern spoke is clogged by boulders; use a rock hammer to break the rocks. Get the blackrock gem and use Altara's scepter. In the north spoke, pass the spiders and follow the path. Push the button and a map piece will appear at the end of the hall. Take the stairs to the second level.

THE TOMB OF PRAECOR LOTH: LEVEL 2

Enter the room at the end of the corridor and speak to Helena. Beyond the portcullis lies the stairs to the third level.

THE TOMB OF PRAECOR LOTH: LEVEL 3

Speak to Silenus, then use your map pieces to reach Level 4.

THE TOMB OF PRAECOR LOTH: LEVEL 4

Pull the chain, then speak to Morphius. To open the south door, use either Silunius's key or the open spell. Walk down the hall. Talk to Lord Umbria, then kill him. Find the hallway leading west. When you reach the pillars, refer to the map below:

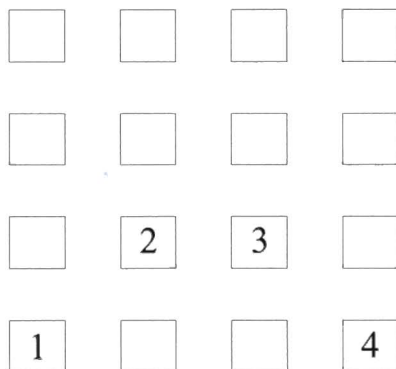

Gaze into the orb, then knock over the candles. Now, when you find Lethe, either kill him or sneak past him. Take the first passage on the left. Open the door and slash your way past the beasts. Open the door along the far wall and pull the chain. Retrace your steps, then head north. Cross the lava pit and talk to Praecor Loth. You must convince him that he truly is dead and that he's been deceived—only then will he give you the horn needed to defeat the Guardian. Return to Britannia, give the small gems to Nystul, and have him treat them. Take them to the portal gem and use the small gems on the big gem. Return to Britannia. Visit Nystul—the answers to his questions follow:

- The Throne Room*
- Four*

Mors Gotha will then burst into the room. Kill Mors Gotha. Once she's dead, go to the Throne room and blow the horn to shatter the gem encasing the castle.



CHAPTER 26

SPELLCASTING 301

GRAPHICS:	☆	STORY LINE:	☆☆
ARCADE:	☆	INTERFACE:	☆
DIALOGUE:	☆	AUDIO:	☆☆☆
ANIMATION:	☆	LENGTH:	☆☆☆
OVERALL ANALYSIS: ☆☆			

SYSTEMS

- ❑ MS-DOS IBM-PC/Tandy & Compatibles

FEATURES

- ❑ *VESA-compatible Super VGA support.*
- ❑ *Richly detailed environment allows unlimited exploration.*
- ❑ *256-color VGA!*
- ❑ *Stunning original art, plus digitized "Girls of Spring Break."*
- ❑ *Pure entertainment—a bawdy adventure filled with hilarious fun! (Naughty and Nice modes).*
- ❑ *Awesome soundtrack—plays at all times and is synchronized with your game play.*
- ❑ *Hilarious digitized sound effects.*
- ❑ *New screen formats for talking with characters, playing casino games, and solving graphical puzzles.*

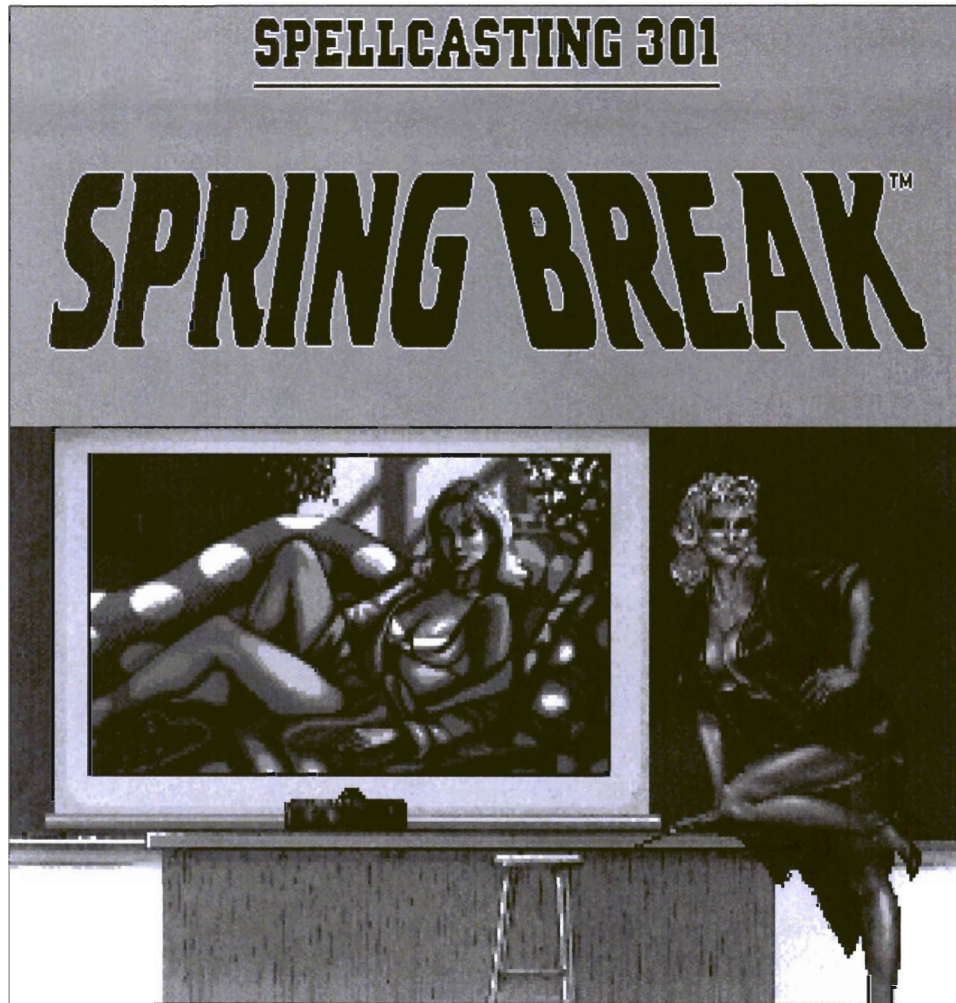

SCENARIO

Ernie Eaglebeak returns in Steve Meretzky's kooky third chapter, *Spellcasting 301: Spring Break*. Released by Legend Entertainment, this farcical adventure flares the nostrils with a scent of coconut oil, bulges the eyeballs with sizzling women, and titters the funny bone with badinage, jokes, and sight gags. Unfortunately, *301* evinces sparse full-screen graphics and animation. This dilemma stems from the nightmarish interface that has stamped this game a "text-adventure."

SPRING-THROUGH

THE MAGIC CARPET

Welcome to the beaches of Ft. Naughtytail. To begin your quest, type in the following:

- TAKE SPELL BOOK, LOOK AT SPRING BREAKERS, LOOK AT BEACH

When the hot babe appears, type in (or click on) the following:

- GREET WOMAN, CAST WOO SPELL, NAUGHTY, SCREW WOMAN

Sorry almighty spellcaster, the dream is over. Oh, well, back to life on campus.

- TAKE ALL, OUT, OUT, NORTHEAST, GET ON THE MAGIC CARPET, GREET FRED, GREET OLLIE, GREET IZZIE

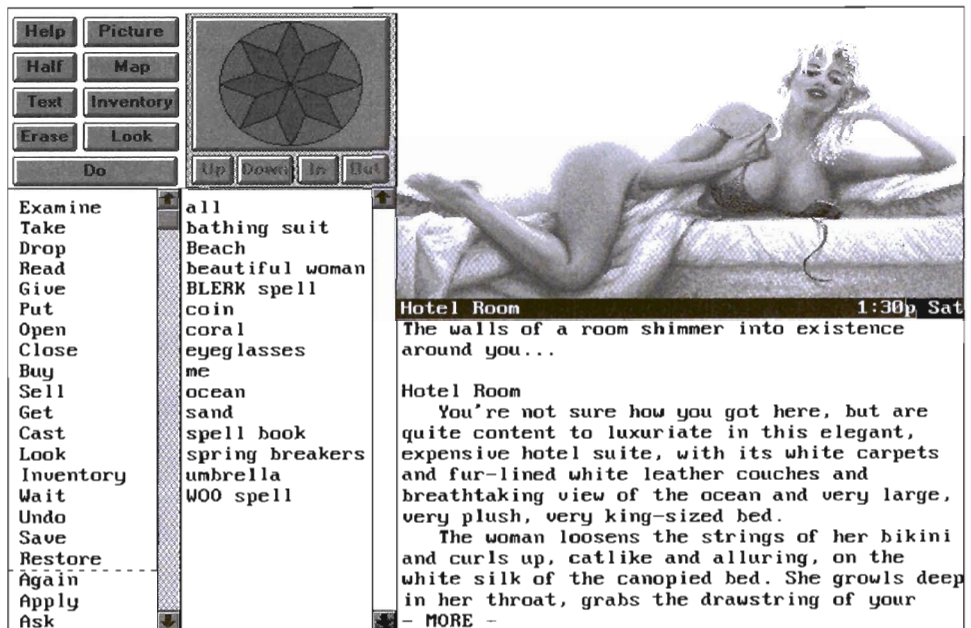

- THROW THE TRUNK, THROW THE LOTION CASE, THROW THE PORTABLE BAR, THROW THE SACK OF GOLD, THROW THE BEER KEG (in any order)

CHAPTER ONE: WORTH THE WAIT

- WALK NORTH, WALK WEST, GREET WOMEN

Examine the area until the Pharts and the Glys show up.

- GREET THE GLYS, LOOK AT THE GLYS, KICK THE GLYS, HIT THE GLYS

Eventually the Glys will challenge you to a weight-lifting contest.

- WATCH ACE LIFT WEIGHTS

When Ralph gets to the 100-pound barbell:

- CAST FRIMP SPELL ON THE BARBELL

When Ralph gets to the 200-pound barbell:

- CAST FRIMP SPELL ON THE BARBELL

When Ralph gets to the 300-pound barbell:

- CAST FRIMP SPELL ON THE BARBELL, LOOK AT RALPH, LOOK AT GLYS
- WALK EAST, GO TO 911, GET IN LINE, LOOK AT LINE, LOOK AT LINE, LOOK AT LINE, BUY TICKET (remember the ticket number)

Continue clicking until your ticket number is called:

- ❑ WALK INTO DOOR, TAKE SUITCASE, SCREW HILLARY, OUT, OPEN OTTO'S SUITCASE, OPEN RATANT BOX, EAST, NORTH EAST, NORTH, SELL SPARE TIRE AND TROPHY, BUY COLOR BOMB, SOUTH, NORTHEAST, PUT COLOR BOMB AND SPELL BOOK IN OTTO'S SUITCASE

Search the area (briefly) for the item(s) you jettisoned from the magic carpet.

- ❑ EAST, EAST, NORTH, TAKE HELLHOUND HAUNCH, SOUTH, SOUTH, TAKE SUCTION CUP GLOVES, SOUTHWEST, DROP HAUNCH, NORTHEAST, NORTH, WEST, WEST, SOUTHWEST, SOUTHWEST, SOUTH
- ❑ BUY UPPSSY SPELL, NORTH, NORTHEAST, NORTHEAST, OPEN UPPSSY BOX, CAST UPPSSY SPELL ON CASINO, SAVE, ENTER CASINO, PLAY RUELETTTO (winning at least \$64)
- ❑ NORTHWEST, SOUTHWEST, SOUTHWEST, SOUTHWEST, WEST, TAKE TWO-BY-FOURS, EAST, GIVE BREAD STICKS TO RAT, NORTHWEST, NORTH, GO TO ROOM xxxx (Moe's room)
- ❑ DROPTWO-BY-FOURS, DOWN, NORTH, NORTH, NORTH, NORTH, NORTH, NORTHWEST, WEST, CLIMB STAIRS, TAKE LIGHTBULB, DOWN, EAST, SOUTHEAST, SOUTH, SOUTH, SOUTH, GO TO ROOM xxxx (Ernie's room)
- ❑ TAKE SID'S BOOK BAG, OPEN BOOK BAG

Click until you get tired, then SLEEP.

CHAPTER TWO: LIFE OF THE PARTY

- ❑ TAKE ALL, PUT SUCTION GLOVES IN OTTO'S SUITCASE, PUT BREADSTICKS IN OTTO'S SUITCASE, UP, EAST, NORTHEAST, NORTH
- ❑ SELL SID'S BOOK BAG, SELL DEFLATED FLOAT, SELL TEXT BOOK, SELL NOSE SHIELD, SELL BREADSTICKS, SOUTH, SOUTH, BUY STUD FINDER (if you can't afford it, either find your sack of gold or win big bucks at the Casino)

SPELLCASTING 301

- NORTH, NORTHEAST, EAST, EAST, SOUTH, SOUTHWEST, WEST

Search the area for an item you jettisoned from the magic carpet.

- TAKE SPELL BOX, OPEN SPELL BOX, WEST

Choose *HARD*.

- Brown, yellow, black, white, yellow, blue, purple, green, black, red, brown, yellow, white, blue
- PUSH BUTTON, SOUTH, THROW COLOR BOMB, DOWN

If you have the lotion case:

- OPEN LOTION CASE, PUT LOTION CASE IN LEMON JUICE, TAKE CASE
- UP, NORTH, NORTH, NORTHEAST, NORTHEAST, NORTHEAST, NORTHEAST, NORTHEAST, SAVE, SOUTHEAST, PLAY RUELETTTO (win at least \$500)
- NORTHWEST, NORTHEAST, BUY KEY, SOUTHWEST, SOUTH WEST, SOUTHWEST, SOUTHWEST, SOUTHWEST, WEST, SIT, ORDER BISQUE, EAT BISQUE, CAST RATANT SPELL ON RATANT SPELL, CAST RATTAN SPELL ON CONCH
- TAKE SOGGY SEAHORSE, EAST, NORTHEAST, NORTH

Kill time until seven o'clock. When the bimbos appear:

- GIVE STUDFINDER TO BIMBOS, GO TO ROOM xxxx (Moe's room)
- GREET PHARTS, LOOK AT PHARTS, TALK TO PHARTS

When the bimbos appear:

- GREET BIMBOS, SCREW BIMBOS, DRINK PUNCH, EAT, EAT MUSHROOMS, TALK TO BIMBOS

After a short animated sequence, click until you get tired. Then SLEEP.

CHAPTER THREE: A MAN'S BEACH IS HIS CASTLE

- ❑ TAKE ALL, DOWN, EAST, NORTHEAST, NORTH, SELL STUDFINDER, SELL MUSHROOMS, SELL TWO-BY-FOURS, BUY PEAWEE BOX, OPEN BOX, SOUTH, SOUTH, BUY SHOVEL (it costs \$48)
- ❑ BUY HEX BOLT, NORTH, SOUTHWEST, WEST, WEST, GIVE SHOVEL TO SID, CAST PEAWEE SPELL ON SID

Kill time until 1 o'clock:

- ❑ TAKE SHOVEL FROM SID

After the contest:

- ❑ TAKE RATCHET, EAST, EAST, NORTHEAST, NORTH, SELL DENIM (if you have it), SELL SHOVEL, SOUTH, SOUTHWEST, NORTH, WEST, NORTH, SOUTHEAST, LOOK IN CANNON, TAKE PIMENTO MOSS, EAST, NORTH, NORTHWEST
- ❑ GIVE HEX BOLT TO WORKMAN, CAST UPPSSY SPELL ON RIGHTHAND RATCHET, GIVE RATCHET TO WORKMAN, TAKE RATCHET, NORTHEAST, TAKE MALE ROC PLUMAGE, PUT PIMENTO MOSS AND SPELL BOOK IN ROC NEST, TAKE SPELL BOOK
- ❑ NORTH, NORTH, WAKE THE BANKER, GIVE NUMBERED KEY TO BANKER, UNLOCK DEPOSIT BOX WITH KEY, OPEN DEPOSIT BOX, TAKE HISINFISA BOX, TAKE HUFINPUFA BOX, OPEN HISINFISA BOX, OPEN HUFINPUFA BOX
- ❑ SOUTH, NORTHEAST, GIVE LIGHTBULB TO SHOPKEEPER, SOUTHWEST, SOUTH, SOUTHWEST, SOUTHEAST, SOUTH, WEST, NORTHWEST, NORTHWEST, WEST, CLIMB STAIRS, GIVE LIGHTBULB TO SORCERER, TAKE TREATIST, DOWN

- ❑ EAST, SOUTHEAST, SOUTH, SOUTH, SOUTH, SOUTH, EAST, BUY ROC CALL (\$79), NORTH, NORTHEAST, NORTH, SELL TREATIST, SELL NUMBERED KEY, SELL RATCHET
- ❑ SOUTH, SOUTHEAST, BUY STRAWBERRY (\$6), NORTHWEST, SOUTHWEST, WEST, GO TO ROOM xxxx (Ernie's room)

Kill time until 10:30 p.m., then SLEEP.

CHAPTER FOUR: A SURE-FIRE FLOP

- ❑ TAKE ALL, UP, EAST, EAST, BUY PILL (\$30), WEST, WEST, NORTH

Kill time until 10:30 a.m.:

- ❑ GIVE PLUMAGE TO VINCE

Wait until the 2 Glys jump:

- ❑ BLOW ROC CALL

CHAPTER FIVE: BOTTOMS UP

- ❑ SOUTH, CAST UPPSSY SPELL ON BARS, NORTHWEST, NORTH EAST, NORTHEAST, NORTHEAST, EAST, CAST SPUNJ SPELL ON TREE ROOT, TAKE SWEET SEAHORSE, EAST, SOUTH, SOUTH

Search the area for an item you jettisoned from the magic carpet.

- ❑ NORTH, SOUTHWEST, WEST, SOUTH, DOWN, (if you have the lotion case: OPEN LOTION CASE, PUT LOTION CASE IN LEMON JUICE, TAKE CASE)
- ❑ UP, PUSH BUTTON, NORTH, NORTHEAST, NORTH, NORTH, NORTHEAST, NORTH, NORTHWEST, WEST, DROP ALL, SAVE,

WEST, GET BIGFINNO BOX, OPEN BIGFINNO BOX, SWIM, NORTH WEST, TAKE OYSTER, SOUTH, TAKE MEDALLION, NORTH, SOUTHWEST

Search the area for an item you jettisoned from the magic carpet.

- SOUTH, SOUTH, TAKE EGG, NORTH, GREET MERMAID, TAKE SCROLL, WEST, NORTH, NORTHEAST, SOUTHEAST, EAST, OPEN LOBSTER TRAP, DROP ALL IN LOBSTER TRAP, WEST, TAKE BERRY PLANT, EAST, EAT BERRY PLANT
- TAKE ALL, (check inventory), EAST, SOUTH, WEST, NORTHWEST, NORTHWEST, WEST, TAKE ALL, EAST, SOUTHEAST, SOUTH, SOUTH, SOUTH, SOUTH, SOUTH, WEST, SOUTH

After the Emcee announces Roxanne:

- GIVE SUCTION GLOVES TO ROXANNE

Kill time until 7:30 p.m. When the contest begins:

- CAST RATANT SPELL ON SPUNJ SPELL (mutating it to Spurj Spell), CAST SPURJ SPELL ON STRAWBERRY, CAST FOY SPELL ON STRAWBERRY, EXAMINE DRINK

Wait for the judge to tell you to begin guzzling:

- PUT ABSORPTION PILL IN DRINK, NORTH, NORTHEAST, NORTH EAST, NORTHEAST, NORTH, SELL BOOT, SOUTH, SOUTHWEST, EAST, BUY FALSIES, WEST, NORTHEAST, SOUTHEAST, BUY LAXATIVE
- OPEN OYSTER, NORTHWEST, SOUTH, GIVE PEARL TO SHOP KEEPER, NORTH, SOUTHWEST, WEST, GO TO ROOM xxxx (Ernie's room), SLEEP at 10:30 p.m.

CHAPTER SIX: BIG TEES

- TAKE ALL, UP, NORTH, NORTH, NORTH, NORTHWEST, WEST, CLIMB STAIRS, GIVE PEARL DUST TO SORCERER, DOWN, TAKE COLLAR, EAST, SOUTHEAST, SOUTH, SOUTHWEST, SOUTHWEST

Kill time until 10:45 a.m.:

- GIVE MY T-SHIRT TO ROXANNE, CAST UPPSSY SPELL ON ROXANNE, GIVE DRY FALSIES TO MONA

CHAPTER SEVEN: WHAT'S THE MATADOR?

- TAKE WATER JUG, NORTHEAST, EAST, EAST, NORTHEAST, NORTHEAST, NORTH, NORTHWEST, FILL WATER JUG, SOUTH EAST, SOUTH, SOUTHWEST, SOUTHEAST, BUY BREAD, NORTH WEST, SOUTHWEST, SOUTHWEST, SOUTH

Kill time until 5 p.m.:

- OPEN PLASTIC BOTTLE, CAST RATANT SPELL ON BIP SPELL

When the bull is in your face:

- CAST BIM SPELL ON BULL, PUT PLASTIC BOTTLE IN WATER TROUGH, WAVE RED CAPE, WAVE RED CAPE, NORTH, SOUTH WEST, CAST BIM SPELL ON ME, NORTHWEST, NORTH, EAST, SOUTHEAST

Kill time until 8:30 p.m.:

CHAPTER EIGHT: HAVE A BRAWL

- OPEN KITCHEMY BOX, CAST KITCHEMY SPELL ON LEAD PIPE, CAST RATANT SPELL ON KITCHEMY SPELL, CAST BOTCHEMY

SPELL ON BANANA PEEL, LOOK AT FIGHT, KISS LOLA

- ❑ NORTHWEST, WEST, CAST RATANT SPELL ON FRIMP SPELL, CAST FRUMP SPELL, NORTHWEST, NORTH, GO TO ROOM xxxx (Ernie's room), SLEEP

CHAPTER NINE: DO THE WAVE

- ❑ TAKE ALL, UP, GO TO ROOM xxxx (Fred's room), POUR WATER ON FRED, DOWN, NORTH, NORTH

Kill time until 10 a.m.:

- ❑ WEAR MEDALLION, SURF

CHAPTER TEN: BRONZE CHEER

- ❑ SOUTH, SOUTH, SOUTH, EAST, BUY RUST SPRAY, NORTH, NORTHEAST, NORTHEAST, EAST, EAST, SOUTH, SOUTHWEST, WEST, SOUTH, DOWN, OPEN CASE, PUT CASE IN LEMON JUICE, GET CASE, UP, NORTH, PUSH BUTTON, NORTH, NORTHEAST, NORTH, NORTH
- ❑ TAKE ABURN TUBE AND APPLY IT TO ME, GIVE CASE TO OLLIE, TAKE PEANUT BUTTER, EAST, EAST, NORTHEAST, NORTH, SELL CASE, SELL NUMBERED KEY, SELL WATER JUG, SOUTH, SOUTH WEST, BUY BREAD, NORTHWEST, NORTHEAST, EAST, EAST, SOUTH, SOUTH
- ❑ OPEN TREASURE CHEST, PUT COLLAR ON SEAL, TAKE SEAL, NORTH, NORTH, WEST, WEST, WEST, NORTHWEST, NORTH WEST, WEST, CLIMB STAIRS, GIVE SELA TO SORCERER, DOWN, EAST, SOUTHEAST, SOUTH, SOUTH, SOUTH, GO TO ROOM xxxx (Ernie's room), SLEEP

CHAPTER ELEVEN: VOLLEY OF THE DOLLS

- ❑ TAKE ALL, UP, SOUTH, SOUTH, WEST, WEST, WEST

Kill time until 9:30 a.m.:

Before the ball is served, CAST HISINFISA SPELL ON VOLLEY BALL. Before the Pharts serve, CAST THE HUFINPUFA ON VOLLEY BALL. When the ball goes over the net, CAST THE HISINFISA SPELL ON THE VOLLEY BALL. Repeat this procedure until the score is 3-0.

- ❑ EAST, EAST, EAST

Kill time until 12:30 p.m.:

- ❑ BLOW WHISTLE (several times), NORTH, NORTH, EAST

Kill time until 2:05 p.m.:

- ❑ GET KEY

CHAPTER TWELVE: DO THE RIOT THING



- ❑ NORTH, UNLOCK WOODEN DOOR WITH KEY, OPEN WOODEN DOOR, EAST, DESCEND STAIRS, TAKE LANTERN, TAKE SPELL BOX, CAST UPPSSY SPELL ON PILLARS, UP, WEST, SOUTH, TAKE BABY SQUID

CHAPTER THIRTEEN: A LOT OF BULL

- ❑ NORTHEAST, NORTHEAST, SPRAY RUST SPRAY ON BARS, NORTHWEST, NORTHEAST, NORTHEAST, NORTHEAST, EAST, EAST, NORTH, SAVE
- ❑ OPEN GESSIBUB BOX, CAST GESSIBUB ON LANTERN, LIGHT FLASHLIGHT, OPEN EGG, NORTH, EAST, EAST, GIVE BABY

SQUID TO GIANT SQUID, EAST, TAKE OKEEDOKEYYO BOX,
OPEN OKEEDOKEYYO BOX

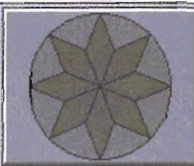
- ❑ EAST, EAST, NORTH, EAST, EAST, EAST, SOUTH, EAST, EAST,
PUT SWEET SEAHORSE IN BIRD BATH, NORTH, NORTH, NORTH,
WEST, SOUTH, WEST, CLIMB TREE, PUT FUZZY SEAHORSE IN
BIRD NEST, CLIMB DOWN TREE
- ❑ WEST, NORTH, NORTH, WEST, BLOW WHISTLE, CLIMB HUMAN
PYRAMID, PUT SOGGY SEAHORSE IN TUREEN, BLOW WHISTLE,
CLIMB DOWN, WEST, WEST, WEST, SOUTH, SOUTH, SOUTH, PUT
GOLDEN SEAHORSE IN POT, EAST, NORTH, EAST, EAST, SAVE,
SIT ON THRONE, CAST OKEEDOKEYYO SPELL ON BULL, LOOK
AT JUDGE, CAST RATANT SPELL ON GESSIBUB SPELL, CAST
DESSIBUB SPELL ON BULL, TAKE BULL'S HEAD, SOUTH

Help	Picture			
Half	Map			
Text	Inventory			
Erase	Look			
Do	Up			Down

Examine
Take
Drop
Read
Give
Put
Open
Close
Buy
Sell
Get
Cast
Look
Inventory
Wait
Undo
Save
Restore

Again
Apply
Ask

all
bathing suit
Beach
beautiful woman
BLERK spell
coin
coral
eyeglasses
me
ocean
sand
spell book
spring breakers
umbrella
WOO spell

Beach 1:25p Sat

>look
Beach
This is one of the incredibly lovely, sun-drenched beaches of Fort Naughtytail.
You see the world's most beautiful woman here.

>greet woman
The woman smiles and says, "Hi! I'm new in town, and I don't know anybody. Maybe we could go somewhere together! Unfortunately, being new in town, I have no idea where to go..."
Your spell book seems to glow and change.

>cast woo spell

MAPS

- 01= Point
- 02= Ball Game
- 03= Lighthouse
- 04= Band Stand
- 05= Restaraunt
- 06= Dead End
- 07= Mansion Grounds
- 08= Parlor
- 09= Middle of Jetty
- 10= Blather Beach
- 11= Resort Lobby
- 12= Redtide Drive
- 13= Sand Bar
- 14= End of Jetty
- 15= Snackside Beach
- 16= Pool Side
- 17= Hotel Lobby
- 18= Plaza
- 19= Arena
- 20= Hall of Fame
- 21= Police Station
- 22= Wharf
- 23= Fort
- 24= Aquarium
- 25= Boulevard
- 26= Souvenir Shop
- 27= End of Road
- 28= Stream Crossing
- 29= Surf Shop
- 30= Bank
- 31= Mining Town
- 32= Foot Hills
- 33= Fish Market
- 34= Village Center
- 35= Pawn Shop
- 36= Littered Street
- 37= Hardware Store
- 38= Prospector Shop
- 39= Groggery
- 40= Gambling House
- 41= Grocery
- 42= Windswept Road
- 43= Mouth of Cave
- 44= Crest of Cliff
- 45= Cliff Road
- 46= Cliff Bottom

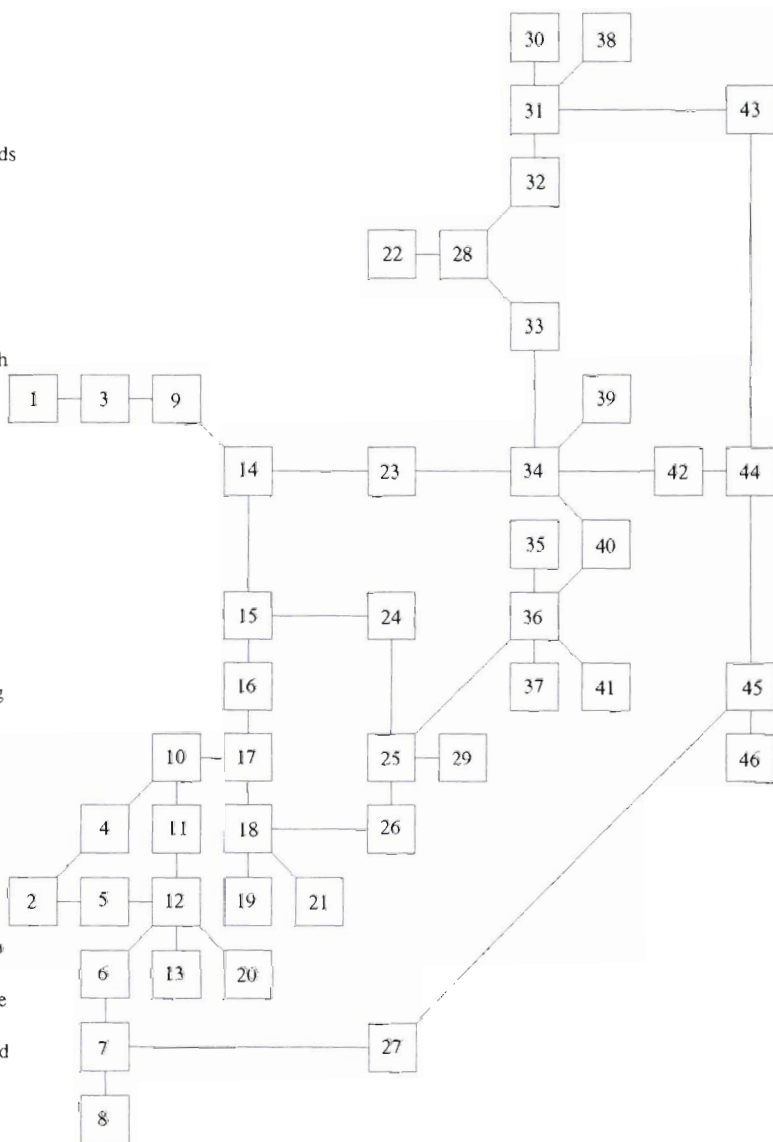

CHAPTER 27

RINGWORLD

GRAPHICS:	☆☆	STORY LINE:	☆
ARCADE:	☆	INTERFACE:	☆☆☆
DIALOGUE:	☆	AUDIO:	☆
ANIMATION:	☆☆	LENGTH:	☆☆
OVERALL ANALYSIS: ☆☆			

SYSTEMS

- MS-DOS IBM-PC/Tandy & Compatibles
- MCGA NOT SUPPORTED

FEATURES

- Truly interactive storyline where your input determines the outcome of the adventure.*
- Lifelike animation and scrolling in a realistic game environment.*
- Point-and-click interface with pop-up menus.*



SCENARIO

Ringworld: Revenge of the Patriarch by Tsunami Media is the cosmic sequel to Larry Niven's two novels (his first book, *Ringworld*, is included with this game). You assume the role of Quinn, a human mercenary who teams up with Louis Wu and the alien Kzin to put an end to the Puppeteers and their breeding experiments of unheard-of proportions. Unfortunately, *Ringworld* has many lengthy, animated sequences that dull game play because they keep the anxious adventurer waiting too long to get back to the action. In addition, this game may be too simplistic for the experienced gamer.

WALK-THROUGH

THE FAMILY CHMEEE HOME

Click the hand cursor on the laser beam (don't worry, it won't kill you). Show the signet ring to the formidable-looking Kzinti. When dialogue responses are required, use the following:

□ 1-1

Suddenly, an army of assassins will invade the home and kill Brother Harrach. Quickly get your stunner from inventory and blast the assassin. Take the infodisk from the dead assassin. Walk one screen south. Enter the flycycle behind the one Kzinti's in. Click on the *SLAVE* button. Exit that flycycle and climb into the first flycycle. Place the infodisk into the center slot of the console. Click on the *MESSAGE* button. After reading the information on the infodisk, press the button labeled *MASTER*. To operate the flycycle, simply press the right throttle (red flashing light).

THE STARCRAFT

Use response No. 2 with Seeker. When you reach the lander bay, stun the guards. After you meet Miranda Rees, use response No. 2. When you see Miranda disconnecting the fibers, use response No. 2, then stun her. After passing the copy-protection, Miranda will be in the AutoDoc. Use response No. 2. Place the infodisk into the slot above the arrow (right side of machine).

CANYON AREA

Use response No. 1 with Olochagach. Use response No. 1 with the Chief. Travel to the lander by walking one screen west. From the hatch area, walk one screen east, then west to enter the elevator. Take the elevator to level two. Locate the food replicator along the west wall. Click the hand cursor on it and select No. 5 (ale). Enter the storage room (east doorway). Take the first-aid kit. Exit the storage room and take the elevator to level one. Exit the lander. After your encounter with Ghalacha, take the rope, then leave her hut by walking east. Take the ladder leaning against the Chief's throne. Exit the hut. Place the ladder

RINGWORLD

between the two doorways. Climb the ladder and click the rope on the rock outcropping. Climb through the left hole.

Hint: Don't climb through the right hole or you'll become toast.

Look closely at the north wall (behind the altar) and you'll see a mural of the peg locations needed to pass the Tech test. Walk one screen south. Snatch the priest's necklace from the left pillar. Climb up the rope, then descend the ladder. Click the hand cursor on the Tech (lower-right corner of screen) and the Kzinti will return. Place the pegs on the Tech as displayed on the mural and place the priest's necklace in the center hole. If you're having troubles passing the Tech, refer to the following instructions:

- Place the moon peg in the top-left hole.
- Place the planet peg in the top-right hole.
- Place the shooting star peg in the lower-left hole.
- Place the north star peg in the lower-right hole.
- Place the priest's necklace in the center hole.

When you reach the silver egg (spacecraft), click the scanner comm unit on it.

STASIS BOX ONE

Talk to Seeker using the talk icon, then use response No. 1. Leave the lander, then save the game. Enter the cave and continue walking west until you're captured by the Flesheaters. After they throw you in the holding cell, use the first-aid kit (which you found in the storage room of the lander) on Seeker. Get the sharp bone fragment. Climb through the small hole located along the west wall (just below the ceiling). Walk one screen west. Cut the heavy cord using the sharp bone fragment. After freeing the bat, take a few steps east and you'll fall back into the holding cell. Click on the exit hole and the bat will appear. He'll give you a bottle of anti-pheromone. Click the bottle on Seeker. Leave the holding cell. After conversing with the bat, follow it by walking west. When you encounter the Flesheaters, stun them with your weapon. Talk to the bat. Click the hand cursor

on the pillar directly below the bat. Get the stasis box. Exit the Throne Room. Click the hand cursor on the boulder next to the pillar: This will allow Seeker to exit the holding cell. Once you're back on the lander, consult the ship's computer and click on the subject, *Stasis Field*. Talk to Miranda and she'll open the first stasis box.

STASIS BOX TWO

After the arcade sequence, and another lengthy (and somewhat annoying) animation sequence, reenter the lander. Use the elevator to reach level two. Enter the storage room and put on the pressure suit. Exit the lander via the airlock. Walk into the ocean. When you're back in the airlock, remove the pressure suit and travel to level one. Activate the flycycle by pushing the buttons on the control panel located just to the left of the elevator. When you reach the sky house, stun the Explorer. Take the jar from the table and click it on the cork in the barrel. Search through the books until you find a slip of paper with the following code:

❑ 2-4-3

Look in the transfer tube and take the key. The dolphin translator box is located below the stool. To access it, turn the stool twice to the right, four times to the left, and three times to the right. Click the key on the lock to open the box. Get the dolphin translator. Leave the sky house and you'll automatically travel back to the lander. Use the computer located on level one (near the southeast side of the room). After the probe's disassembled, take the mechanical arms. Leave the lander via the hatch. Give Skeenar the dolphin translator box, the jar filled with a green substance, and the mechanical arms. Take the stasis box.

STASIS BOX THREE

Speak to the green-skinned slave. After you have the slave's clothing, walk west to reach the city. After being escorted into the castle, talk to the overseer, then grab a handful of straw. Now walk one screen west, one screen east, and one screen south. Talk to the Kzinti telepath (obtaining the soiled tunic). Leave the dining hall and walk east to reach the entrance to the Patriarch's private chambers. Attempt to enter the chambers and the guard will stop you. Click the soiled tunic on the guard and he'll allow you to pass. Next to the bed is a candle

RINGWORLD

holder. Take a candle, then enter the closet by walking north. To open the secret compartment, click the hand cursor on the right feather of the column carving. Take the short sword. Exit the closet by walking south. Click the short sword on the right column. Take the headpiece. Place the straw on the bedspread and ignite it with the candle. Leave the bedroom and walk north onto the balcony. Use the scanner comm unit. After arriving at the canyon area, click the stasis field negator on the spacecraft. When you have the close-up view of the hull, click the hand cursor on the small, square panel. Click on the squares in the following order:

❑ 3-4-1-5-2-6

Click the helmet on the alien. Click the eye cursor on the hull. Click the magnetic key device on the upper panel. Click the stasis box on the energy source. Take the Tnuctipun anti-matter concentrator (silver orb). Remove the green modules from the slots. Click the neural wave nullifier on the alien. Click the hand cursor on the alien. When you're hovering near the Destroyer, click the green module on the lander to win the game.

CHAPTER 28

ERIC THE UNREADY

GRAPHICS:	☆☆	STORY LINE:	☆
ARCADE:	☆☆	INTERFACE:	☆
DIALOGUE:	☆☆	AUDIO:	☆☆☆
ANIMATION:	☆	LENGTH:	☆☆
OVERALL ANALYSIS: ☆☆			

SYSTEMS

- MS-DOS IBM-PC/Tandy & Compatibles

FEATURES

- New menu-driven system for conversing with characters.*
- Intriguing mix of interfaces creates a constantly changing graphical scene.*
- Breathtaking Fantasy Art.*
- 256-color VGA.*
- Awesome soundtrack.*

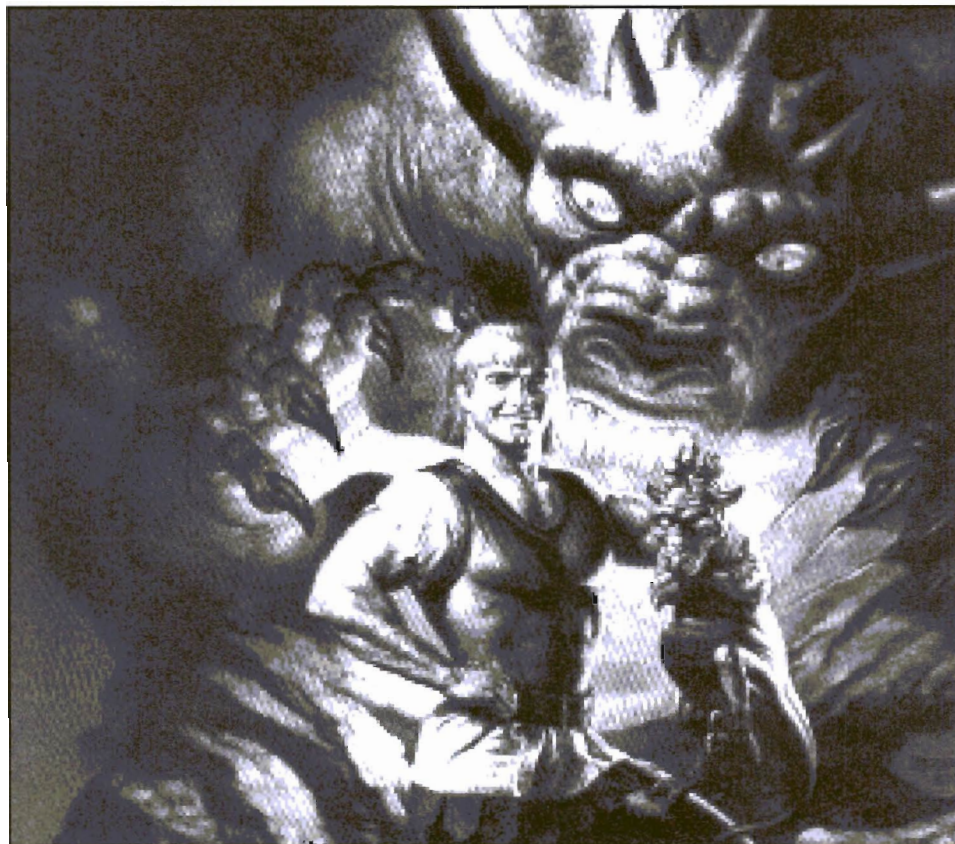

SCENARIO

Eric the Unready by Legend's Bob Bates is a farcical adventure lampooning everything from TV shows and movies to other adventure games. You assume the role of the clumsy knight, Eric T. Unready, who must leave a swath of destruction down an inane path to free the Princess Lorealle from the clutches of the wicked witch, Queen Morgana, and her lover, Sir Pectoral. Since this game uses an interface identical to that of the *Spellcasting* series, most of the graphical screens are small, filling only about one-fourth of the viewing screen, and contain only sparse animation. This interface, being the tedious nightmare that it is, targets esoteric gamers who enjoy perusing gobs of text. Therefore, don't be hoodwinked by the mouse support—you still need to cycle and search through hordes of verbs and nouns to interact with the game.

WALK-THROUGH

DAY 1: THE PIG AND THE PRIVY



To talk to any of the many characters in the story, double-click on them. Begin by talking to the farmer.

- ❑ WEST, OPEN MEDICINE CHEST, TAKE ROPE, TAKE FLASK, LOOK AT THE VIAL, TAKE THE VIAL, LOOK AT THE BOTTLE, TAKE HOG-WILD, EAST, NORTHEAST
- ❑ TAKE NEWSPAPER, READ NEWSPAPER, TIE ROPE TO THE HOOK, CLIMB THROUGH THE BENCH, GIVE HOG-WILD TO PIG, CLIMB UP ROPE, SOUTHWEST, KISS PIG, WEST

DAY 2: THE QUEST FOR LOREALLE

Advance the time by pressing Z twice.

ERIC THE UNREADY

- ❑ TAKE HELMET, TAKE CARD, EAST, TAKE NEWSPAPER, READ NEWSPAPER

After the Sergeant At Arms drags you to the Union Hall, advance the time by pressing Z five (5) times.

- ❑ WEST, WEST, GIVE THE CARD TO GIOVANNI

Refer to *Giovanni's Custom Fit Guide* to pass the copy protection.

- ❑ WEAR CLOAK, LOOK IN POCKET, EAST, SOUTH, PUT HELMET IN DUCKPOND, WEST, NORTH, NORTH, PUT BEAN IN THE GARDEN, PUT WATER ON BEAN, CLIMB THE BEANSTALK, SOUTH, SOUTH
- ❑ EAST, GIVE COIN TO BOBBIN, WEST, NORTH, NORTH, NORTH, TAKE KINDLING, SOUTH, SOUTH, SOUTH, EAST, PUT KINDLING IN FIREPLACE, WEST, NORTH, GIVE COIN TO PONCE, WEAR EARMUFFS

Advance the time by pressing Z twice.

- ❑ NORTH, NORTH, CLIMB THE STAIRS, Z, Z

When you reach the Village Green:

- ❑ EXAMINE BOOK, TAKE THE BANANA, THROW BANANA IN DUCK POND

DAY 3: THE NOT SO GREAT UNDERGROUND EMPIRE

- ❑ TAKE THE NEWSPAPER, READ NEWSPAPER, WEST, WEST, POUR FLOAT IN TREE ROOTS, WEST, MOVE THE BRANCHES, OPEN THE TRAP DOOR, CLIMB THE STAIRS

The screen will change to “all-text mode” for only one turn:

- ❑ OPEN MAILBOX, TAKE THE MAIL, LOOK AT THE BOARD, TAKE THE BOARD, WEST, NORTHEAST, SOUTHWEST, SOUTH, GIVE MAIL TO ED McDWARF, NORTH, EAST, OPEN DOOR WITH THE PICKAXE, ENTER THE HOLE, LOOK AT THE LIVING ROOM, OPEN THE TROPHY CASE, PUSH THE RUG, OPEN THE TRAP DOOR, OPEN THE TROPHY CASE, TAKE THE BEARD
- ❑ UP, TAKE THE PILE OF BONES, DOWN, WEST, WEST, KNEEL, WEAR BEARD, SOUTH, GIVE THE MAIL TO ED McDWARF, GIVE THE LICENSE TO ED McDWARF, STAND, TAKE OFF BEARD, WEST

If your memory is as good as that of your computer's, you'll have no problem winning the *Concentration* game. Play the game until you win the slingshot.

- ❑ SOUTHWEST, SOUTHEAST, NORTHEAST, BUY STARTER ROCK, PUT STARTER ROCK IN SLINGSHOT, SOUTHWEST, PUSH LEVER, GET IN THE SEAT, PUSH THE GREEN BUTTON, SHOOT THE LEVER, STAND, TAKE THE PITCHFORK, TIE THE BUNGEE CORD TO THE BRANCHES, JUMP, EAST, EAST, UP, UP, DROP HEAD REST, STAND ON HEADREST, PUSH SLAB

DAY 4: HOWARD JOHNSONS AND THE ATTACK TURTLES

- ❑ NORTH, TAKE THE NEWSPAPER, READ THE NEWSPAPER, EXAMINE BRUCE, EXAMINE MENU, Z, Z, Z, Z, EXAMINE THE COMMEMORATIVE BOOK, GIVE COUPON TO BRUCE, READ MENU

Take a break and have a few drinks. Be sure to order Mead Lite.

- ❑ SOUTH, WEST, WEST, LOOK AT THE BERRIES, LOOK AT THE RUNGS, NORTHWEST, LOOK AT SEAL, LOOK AT TURTLES, GIVE TORT-EASE TO TURTLES, EAST, TAKE BRANCH, WEST, UP, PUT BRANCH IN THE PITCH, DOWN, MELT SEAL WITH TORCH, TAKE BLOB OF WAX, PUT BLOB OF WAX ON RUSTY KEY, NORTH,

WEST, EAST, NORTH, GIVE BLOB OF WAX TO HOWARD JOHNSON, SOUTH, WEST, NORTHWEST, OPEN DOOR WITH SHINY KEY

Play *Wheel of Torture* until you win the crescent wrench.

DAY 5: THE DRAGON AND THE WHOOPEE CUSHION

- ❑ TAKE NEWSPAPER, READ NEWSPAPER, WEST, READ SCROLL, NORTH, SPIT, Z, Z, Z, INSULT BOY, Z, Z, Z, Z, Z, WEST, EXAMINE BOAR, GIVE APPLE TO CHEF, TAKE APRON, WEAR APRON, NORTHEAST, SHOOT THE TARGETS, AGAIN

Continue striking the targets until you win the chicken, the whoopee cushion, and the noisemaker.

- ❑ SOUTHWEST, EAST, EAST, INSULT THE JUDGES, MOON THE JUDGES, SIT ON WHOOPEE CUSHION, WEAR THE FOOL'S CAP, WEST, WEST, PLAY, TURN OVER BLUE SHELL, TALK TO MUSICIAN, EAST, CLIMB THE MAYPOLE, NORTH, WEST
- ❑ TAKE RUBBERBAND, TAKE LEECH, TAKE MARBLE, CLOSE THE SHADE, TAKE MARBLE, PUT THE RUBBERBAND ON THE VIPER, TAKE THE MARBLE, TIE BUNGEE CORD TO AARDVARK, TAKE THE MARBLE, STAND ON THE FLOORBOARD, TAKE THE MARBLE, EAST, READ THE SIGN, Z (until 11), Z, Z (until 12), Z, READ NOTE, NORTH
- ❑ TALK TO LILY, SOUTH, Z (until 1), Z, EXAMINE GLOVES, THROW LEECH TO THE JUGGLERS, WEAR GLOVES, SOUTH, CLIMB THE MAYPOLE, NORTH, GO TO DWESSING WOOM, GIVE BOA TO LILY, SOUTH, SOUTH, WEST, Z, Z, GIVE REED TO MUSICIAN, WEAR SUNGLASSES, PLAY

Using your trusty magic glasses, flip over the correct shell.

- ❑ EAST, NORTHEAST, GIVE WOODCUTS TO THE BARKER, SOUTH-WEST, SOUTH, WEST, SHOOT THE DRAGON'S _____

(In order to defeat the dragon, shoot the part of the dragon that corresponds to the part of you that he attacked.)

- ❑ TAKE DRAGON, TAKE THE STEAK

DAY 6: THE VIRGINS AND THE GODS

- ❑ TAKE THE NEWSPAPER, READ THE NEWSPAPER, MOON THE UNICORN, TAKE THE LEAF, DOWN, WEST, TAKE THE ROBE, WEAR THE ROBE, LOOK IN THE POCKET, READ SIGN, RING THE FOURTH BELL, READ THE NEWSPAPER TO THE GIRL, GIVE HANKY TO THE GIRL, Z, PUT LEAF IN HANKY, Z, NORTH
- ❑ GET IN VAT, WEAR RING, Z (until 10), Z, GIVE BOOK TO GIRL, Z, Z, Z, JUMP IN MOLOCHI, Z, Z, LOOK AT THE GOD, SOUTHWEST, LOOK AT PALACE, WEST, TAKE GOLDEN KEY, NORTH, SOUTH, EAST, ENTER THE PALACE, GIVE NOTE TO CLIO, Z, GIVE NOTE TO MORTY, EXAMINE TOKEN, Z, NORTH, TAKE NOTE, SOUTH, GIVE NOTE TO CLIO, Z, Z, Z
- ❑ GIVE NOTE TO MORTY, EAST, TAKE WOAD AND COSTUME, EAST, TALK TO REPAIRGOD, GIVE TUIT TO REPAIRGOD, PUT COIN IN SLOT, NORTH, Z, READ LIST

Order *Setting Up Sodom/Gomorrah: Priming the Fountain* from the list.

- ❑ SOUTH, SOUTH, GIVE BOOK TO RICHARD, READ BOOK, NORTH, EAST, LOOK AT MACHINE, PUSH CRANK, TAKE THE SLIMEWIG, WEST, READ THE BULLETIN BOARD, AGAIN, CALL 1-800-DOMINUS, (wait 40 minutes), WEST, NORTH, WEST, NORTH, TALK TO NORTH WIND, GIVE CAKE TO NORTH WIND, TAKE THE DRAGON, PULL DRAGON'S TAIL, BURN CANDLES WITH DRAGON, SOUTH

- ❑ TAKE THE GOLDEN KEY, EAST, NORTHEAST, GIVE NECTAR TO GOD, AGAIN, AGAIN, TAKE THE EGG, SOUTHWEST, DROP EGG, WEAR COSTUME, WEAR WOAD, GET ON THE EGG, EAT SLIME-WIG, TURN AROUND, TURN AROUND, SQUAWK, CLIMB THE STAIRS, OPEN LOCK WITH GOLDEN KEY, TAKE THE CROW BAR, LOOK AT CORK

DAY 7: SWAMP TREK

- ❑ TAKE NEWSPAPER, READ NEWSPAPER, GET ON RAFT, GIVE BERRIES TO ZULU, Z, Z, Z, LOOK AT WHIRLPOOL, AGAIN, OPEN CAGE, LOOK AT BOLT, TAKE BOLT, NORTHWEST

After piloting the raft to Milligan's Island:

- ❑ TAKE UMBRELLA, Z, TAKE BOTTLE, LOOK IN BOTTLE, TAKE MATCHBOOK, EXAMINE MATCHBOOK

After playing *Connect-the-Dots*:

- ❑ PUT MATCHBOOK IN BOTTLE, DROP BOTTLE, Z, Z, Z, Z, TAKE BOTTLE, LOOK IN BOTTLE, TAKE THE CERTIFICATE, READ THE CERTIFICATE, NORTHWEST

After piloting the raft to Treasure Island:

- ❑ READ SIGN, GET OFF THE RAFT, SIT ON RAFT

Pilot the raft to Monkey Island:

- ❑ TAKE COCONUT, YOOHOO, GIVE BANANA TO THE MONKEY, TAKE THE COCONUT, GET ON THE RAFT

Pilot the raft to Lilliput:

- PUT COCONUT ON CONVEYOR BELT, PUT UMBRELLA ON THE CONVEYOR BELT, LOOK AT THE LEVER, PULL THE LEVER
- PUT THE DRAGON ON THE CONVEYOR BELT, SIT ON RAFT

Pilot the raft to the iceberg:

- SIT ON RAFT, (steer toward Gnoll Island), GET OFF RAFT, EAST, PUT COCONUT IN GUILLOTINE, PUT UMBRELLA IN COCONUT, WEST, SIT ON RAFT, (steer toward Phantasy Island), GIVE DADDOO COCONUT

DAY 8: AND THEY ALL LIVED HAPPILY EVER AFTER?



TAKE THE NEWSPAPER, READ THE NEWSPAPER, TAKE TAR WITH PITCHFORK, TAKE THE CANDYGRAM, ATTACK THE BIRD WITH THE CROWBAR, PUT STEAK ON EYE, CUT LIGHTNING WITH BOLT CUTTERS, TURN MOON WITH WRENCH, TURN THE HOURGLASS, READ

BOOK, LOOK IN THE CRYSTAL BALL, READ BOOK, TAKE EYEBALLS, PUT EYEBALLS IN THE SKULL, HOOT

Choose IIIVX from the menu:

- GO TO PASSAGEWAY, WEST, TAKE BROOMSTICK, LOOK AT THE MAKEUP, TAKE THE MAKEUP, EAST, (wait until 10:50), PUT MAKEUP ON CHAIN, WEST, OPEN WINDOW, GET ON BROOMSTICK (remain on broomstick until you reach the crawlspace), AGAIN, OPEN TRAP DOOR, UP, Z (eight times), GIVE CANDYGRAM TO WITCH, LOOK AT LOREALLE, TAKE LOREALLE, OUT, BLOW WHISTLE, GET ON DUCK

CHAPTER 29

THE PROPHECY

GRAPHICS: ☆☆

STORY LINE: ☆☆

ARCADE: N/A

INTERFACE: ☆☆☆

DIALOGUE: ☆

AUDIO: ☆

ANIMATION: ☆☆

LENGTH: ☆☆☆

OVERALL ANALYSIS: ☆☆

SYSTEMS

- MS-DOS IBM-PC/Tandy & Compatibles
- CD-ROM (no release date)

FEATURES

- Smooth, fluid animation, digitized actors, astounding fantasy backgrounds, and full-motion video make this the most visually stunning adventure available!*



SCENARIO

The pernicious wizard Kraal plans to overtake the kingdom of Blue Rocks via the Great Eclipse—which happens in three short days. You, Sir Ween, are the Chosen One sent to woo fame by garnering the missing pieces of the Revuss of Time before the sky fades to eternal darkness. Coktel Vision (a division of Sierra and creators of *Inca*) has leapt into the adventuring world with a style of its own. Unlike the celestial adventures we've grown accustomed to, *The Prophecy* eliminates the freedom of sauntering by shackling you to a couple of screens until you find the key necessary to continue (thus making

a location of object list and maps unnecessary). Once you advance to the next level, you can't backtrack. Consequently, you must carve a memory slot often during game play. The playing field fills only two-thirds of the screen and the graphics are nice, but not mind-boggling. The animation is acceptable and the interface effortless. The intricate yet intelligently solvable puzzles make this quest extremely addictive.

WALK-THROUGH

THE LAB

Click on the crystal ball and you'll meet Petroy. Take the copper ball from the table and the tongs from the fireplace. Open the cupboard and grab the lard and the knife. Enter the lab via the north doorway. Shatter the skull using the gray key. Inside the skull you'll find a magic ring. After reading the book next to the skull, take the bottle of digitalis, the bag of seeds, and the tablet. Remove the picture from the back wall and hang it on the west hook. Click on the hideaway. Click the digitalis on the seeds. Click the seeds on the hideaway. Take the mold from the hideaway. Click the magical ring on the copper ball to transform it into a cauldron. Exit the laboratory and walk to the porch (west doorway). Take the straw from the railing. Use the tongs on the reed, then on the guardrail.

Hint: Be sure to take the reed before taking the guardrail (the strength of the rail will break the tongs).

Place the wood and the straw on the hearth. Use the knife on the reed. Use the flute on Ween. Use the strawberries on Urm. Accept Urm's gift of gold and grab the jar of jam. Use the flute on Ween again. Give Urm the jam. Now use Urm on the fireplace. Place the cauldron over the flames. Drop the gold into the cauldron. Pour the melted gold into the key mold. Use the golden key on the padlock in the lab. Take the half-statue, then click on the trap.

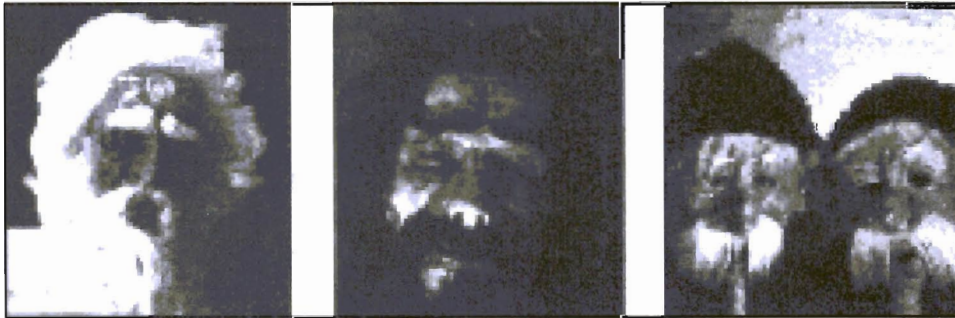

THE PRECIPICE

Take the tibia from the skeleton. Remove the planks blocking the mouth of the cave. Enter the cave and grab the rope. Change the cauldron into a copper ball by clicking the magic ring on the cauldron. Place the copper ball into the orbit of the skull in the cave. Take the moon stone, then remove the copper ball (notice that the trigger lever is stuck). Exit the cave and use the torch on the hearth (then place the torch in inventory for later use). Change the copper ball into a cauldron. Place the cauldron on the hearth. Put the lard in the cauldron. Take the cauldron into the cave. Click on the skull. Use the tibia on the skull's *opening*. Use the oil (melted lard) on the tibia and flip the lever. Leave the cave. Use the rope on the planks. Use the planks on the stone. I'll see you at the seal.

THE SEAL

Click on the upside-down skull and take the sun stone. Find the tibia, then click it on the spear. Use the tibia/spear on the curtain, then on the blackberries. Summon Urm using the flute and offer him the blackberries. Use Urm on the hole above the door. Use Urm's key to unlock the east door. Enter the chamber and use the sword on the statue head. Open the trap and collect *all* the acid in your cauldron. Click on the mechanism in the trap. Enter the following combinations (from their initial settings) to reveal two hideaways:

- Sword-Sun-Crown
- Sword-Moon-Crown

Take the effigy and the elixir from the hideaways. Exit the chamber and click on the borgol. Place the torch into the torch holder. Click on the seal. Use the acid on the seal. Place the sun stone into the left niche, followed by the moon stone. Place the effigy in the right niche and you're in!

THE PATH TO THE TEMPLE

Click on the path (bridge) and Kraal's messenger will appear. Take the feather and click it on the chest. Read the parchment, then grab the vials containing venom and pollen. Place the venom, the pollen, and the elixir into the cauldron. Click *Potion 1* on the monster and cross the bridge.

THE PROPHECY

THE ORIVOR

Use the sword on the rock. Place the cauldron over the hole. Click on the giant strawberry bush. Click on the hole nearest the water. Now click the orivor on the pile of gold. Grab your cauldron and head toward the temple's entrance.

THE TEMPLE ENTRANCE

Use the venom on the viper. Take the tiara. Use the torch to burn the brambles (thorns). Use the ring on the cauldron, then use the tiara on the copper ball: This will give you a pipe. Use the pipe on the wasp trap. Use the trap on the wasps.

THE DRAGON

Is the dragon obstructing your journey? Well, try changing him into a creature you've already slain—a wasp. Click on the lower parchment until your opponent has transformed into a wasp. Collect some cherries, then use the wasp trap on your opponent. Summon your buddy Urm, feed him, then use Urm on the wasp trap.

THE DOOR PUZZLE

After clicking on the borgol, place the tablet over the engraving. Click on the eye (east side of room). Ask Petroy to translate the writing on the tablet. Now you must open the door below the sword (if the tablet is blocking the door mechanism, click on the eye). To unlock the first door, click on the following icons:

Bow-Animal-Cauldron-Roast-Skull

Welcome to the second door-chamber. Begin by snatching the vial from the mechanism, then click on the following icons:

1-3-4-Skull

THE GUARDIAN

Place the fallen gargoyle on the ledge. Grab the coin from the enclave. Find the hammer and place it in inventory. Place the wood stack on the hearth. Remove

the loose stone from the north wall. Take the rag from the statue and use it to polish the statue's quartz eyeballs. Use the hammer on the statue's arm. Place the amphora on the hearth. Get the vial from inventory and place it on the enclave. Click on the fountain and remove the lichen. Place the lichen on the hearth. To activate the fountain, click on the fangs in the following order:

❑ 3-12-4-6-3

Moisten the rag. Use the venom on one of the statue's quartz eyeballs. Use the pipe on the quartz snake. After the snake bends the pipe into a coil, place the coil on the gargoyles. Use the pollen on the remaining eyeball and grab the flower. Place the flower on the hearth. Grab a handful of leaves and place them on the hearth—this will plug the leaks. Place the wet rag over the coil. Use the magnifying glass on the beam of light. Give the potion to the Guardian. Take the pipe and change it into a copper ball. Place the copper ball on the small statue, then click on the small statue.

THE SANCTUARY

Remove the glove from the statue, the necklace from the chalice, the mirrors from behind the tapestry, and the key from the vase. Use the glove to retrieve the heart guarded by the trap door spiders. Place the heart in the site of the statue. Click the chalice on the scales. Click on the tabernacle. Turn the head of the statue and enter the passage. Place the mirrors in the openings located on either side of the door. Unlock the door with the key you found in the vase.

TEMPLE GARDENS

Use the right door to enter the Temple Gardens (if you decide to enter via the left door, you're on your own). Find and take the bag. Use the bag on the snake, then pull the bond (to close bag). Use the snake on the mongoose. Take the root from the lower-left corner of the screen. Use the necklace on the copper ball to create a sword. Use the sword on the larch to gather resin in the root. Use the resin on the monsters. Change the sword into a pipe. Use the pipe on the water to redirect its flow. Place the pearls and the digitalis into the basin. Locate the femur and place it in the basin. Give this mixture to the greedy Queen, then cut the rope with the sword.

THE PROPHECY

THE WORM

Combine the following items to create a pickax: wood, the horn, and the tropical creeper (liana). Use the baton in the lower-left corner of the screen. Use the pickax near this location to reveal a spring of water. Fill the bowl with water and pour it over the mushrooms. Click on the eye of the skull. Use the pot to collect resin from the tree. Place the resin on the flower. When the bird attacks the bug, hurl a stone at it. Click on the eye of the skull and place the worm on the giant mushrooms.



SEA OF SERENITY

Click on the monster. Find and take a handful of strawberries. Pick up the flute and summon Urm. Give the gold to the monster, then grab the haversack. Use your sword to cut the bamboo, which can be used as a mast. Place the oar in the notch of the boat to create a makeshift rudder. Use the hammer on the ship ribs, then affix the ribs to the boat. Fill the wicker traps with coconuts and click them on the ship ribs. Use the net to catch a fish. Fillet the fish using your sword and offer the fish eggs to the spider. After the spider spins you a sail, save the game. Place the sail on the boat and head out to sea.

Hint: The following sequence is time-sensitive.

After squashing the bug, grab the floating bottle and remove the cork. Open the hatch by clicking the hammer on the padlock. Get the tar and use it on the cork. Use the cauldron to bail the water. Use the tar-covered cork to plug the hole. Secure the cork by striking it with the hammer.

VOLCANO ISLAND: THE OLD MAN

Get the key from the boat and use it to unlock the door. Grab the shovel and exit the hut. Use the shovel to dig as many holes as possible (the shovel will break

when you've uncovered all the buried treasures). Gather the objects and use your sword to open the oyster. Present these items to the greedy old man, including the coin you took from the enclave. Also summon Urm and give the old man Urm's gift of gold. Now use the sword to break the planks on either side of the hut—this'll give the old fart some fresh air. After the old man vanishes, use the sword to break the planks next to the pull ring (don't use the prankish pull ring).

NATURE FAIRY

Set the cauldron over the west hole. Click on the orivor and he'll give you a pendulum. Move the pendulum around the scene until it reveals the location of buried gold. Use the sword to uncover the gold bar. Present the gold to the orivor. In return, the orivor will give you some rope. Use the sword on the left branch, then on the branches to the right. Click the rope on the large branch to construct a bow. Click the bow on the walnut. Use your pipe to gather the feathers. Affix the feathers on the arrows to stabilize their flight. Nock an arrow and launch it at the walnut. Use the sword on the walnut to release the Nature Fairy.

THE OLD MAN: VISIT TWO

Take the purple feather and use it on the chest. Take the vials from the chest and grab a handful of strawberries. Click on the worm. Click the cane on the glass eye and the old man will reappear. Use the flute to summon Urm. Give Urm's gold to the old man. Pick some red currants and offer them to Urm. Use Urm on the old man. Now it's time to concoct some potions: Combine the venom and the pollen in the cauldron. Use this potion on the mushrooms and they'll grow. Take the truffle. Place the truffle and the venom into the cauldron to create the lucifery potion. Use this potion on the ruby. Combine the venom and the pollen in the cauldron and use it on the grass. Fill the cauldron with water and place it on the hearth (over flames). Place the camomile into the cauldron and you'll have some healing tea. Give the tea to the worm and he'll be cured. Click the worm on the mushrooms, then walk one screen west. Now place the truffle and the pollen into the cauldron and you'll have a batch of vitality potion. Use the vitality on the borgol. Click the pollen on the quartz. Click on the flower and remove the pistil. Give the pistil to the ant, then locate the three lost grains of sand and the axle. Use the sword on the bush to reveal a door. Place the truffle and the pollen into the cauldron. Use the vitality potion on the statue. Pull the lever, then walk one screen

THE PROPHECY

east. Click on the mechanism along the north wall. Fit the axle in the orifice. Pull the lever and take the key. Walk one screen west. Use the key on the lock. Place the venom, pollen, and the truffle into the cauldron. Use the change potion on the grill. Click the venom on the snakes. Use the lucifery potion (truffle plus venom) on the ruby. Fill the cauldron with water and extinguish the flames.

THE LAIR'S ENTRANCE

Welcome to the lair's entrance. The trick is to illuminate all the niches with fireflies before pulling the levers.

Hint: Don't pull the levers until all the niches have been illuminated!

Grab the bowl and place it in inventory. Click on the ornament, then use the sword on the hole. Keep digging until you find a ruby. Use the lucifery potion on the ruby. Remove the jewel from the ashes and pick up the flawed jewel from the floor. Now click on the right-front niche several times. When the creature spits glue at you, use the bowl to gather the adhesive. Use the vitality potion on the jewel. Use the sword on the crack (left side of screen). Grab the firefly. Use the glue on the firefly. Use the sticky firefly on an unlit niche and another jewel will appear. Repeat this procedure until all the niches are illuminated (mend the broken jewels using adhesive). Have you noticed the small hole in the right-rear niche? Place the copper ball into the hole, then click on the copper ball. If you need an extra jewel, place the twig (which you found in the right-front niche) into the opening just above the statue's hand. By pulling the levers in the niches, you'll illuminate the letters on the far wall. All the letters must be lit for you to continue. To do this, begin at the left-rear niche and pull the lever once. Continue counterclockwise pulling the second lever twice, and so on. When all the letters are aglow, use the bow to spell the name:

☐ KRAAL

KRAAL'S PRISON

Grab the nail from the west wall. Click on the locking mechanism and place the

nail at seven o'clock in the left panel. Click on the needle and the sixth bar will raise. There you'll find a pin. Place the nail at three o'clock in the left panel and the pin at nine o'clock in the right panel. Click on the needles and you're free.

THE REVUSS OF TIME

Slow down the pendulum by sliding the right lever all the way down, then all the way up. Repeat this procedure with the middle and the left lever, consecutively. Close the lever window and open the left niche by clicking on the following letters:

D-J-E-L

Remove the knife from the statue and use it on the bamboo twice (you'll find the bamboo on the floor near the center of the room). Summon Urm. Pick up the stone and place it in the hole of the carving. Click on the following letters:

A-Z-E-U-L-I-S-S-E

Combine the statues, then place the grains of sand into the Revuss of Time.

CHAPTER 30

INCA

GRAPHICS:	☆☆☆	STORY LINE:	☆☆
ARCADE:	☆☆☆	INTERFACE:	☆☆☆☆
DIALOGUE:	☆	AUDIO:	☆☆☆
ANIMATION:	☆☆☆	LENGTH:	☆☆
OVERALL ANALYSIS: ☆☆☆			

SYSTEMS

- MS-DOS IBM-PC/Tandy & Compatibles
- CD-ROM (June 1993)

FEATURES

- Motion picture-quality, video-captured actors and action.*
- Sensational new-age stereo soundtrack with authentic Inca instruments. (Played on radio stations throughout Europe.)*
- Easy-to-use interface gives you smooth, fast-panning screen motion with fast-action realism.*
- Intriguing and challenging puzzles of ancient Inca folklore.*
- Travel through time and space from ancient Peru to futuristic outer space star systems.*
- Exciting arcade sequences through winding outer space canyons, dungeon-like mazes, and even Spanish galleons in outer space.*



SCENARIO

Distributed by Sierra On-Line for Coktel Vision, *Inca* is an entirely new concept in computer gaming. The trilogy of puzzle-solving, mythical role-playing, and deep-space combat simulation catapults you through time and space. You assume the role of El Dorado, the golden champion of the lost Inca empire, guided by the spirit of Huayna Capac to rekindle the sun Inti and attempt to resurrect the mighty Incan empire. If you dislike arcade, you'd best shy away from *Inca*, since you must outwit the enemy by means of your arcade skill and the firepower of the Tumi fighter. (By arcade, I'm referring to those areas in the game requiring timing, reflexes, and visual skills.)

WALK-THROUGH

THE OPENING COMBAT SEQUENCE

After maneuvering the Tumi past the meteors, you'll be given a save code. In the game version I played, the code was:

- ❑ 58566548 (save code)

After entering the canyon, blast the enemy vessels before they reach the end of the canyon—just watch out for the mines they release behind them. If an enemy vessel's behind you, decrease your speed and allow it to pass.

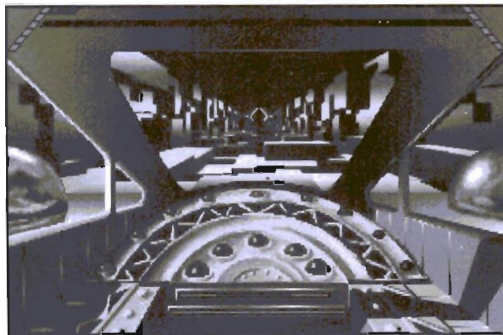

- ❑ 16126348 (save code)

THE SACRED JEWELS

Begin by clicking on the control cover. Then click twice on the right dial and once on the left dial. Remove the three Inti's stones. Click on the angular stones. Click on the large hole three times (setting the golden sun to the design resembling the carvings). Place the golden sun in the hole and the Inti's stones in the melting pots. Take the sacred tumi. Click on the door.

THE MAZE

Walk four screens north, two screens west, and one screen south while blasting any enemies that get in your way. Use the tumi on both knots, then on the bamboo. Take the gold coin and the bamboo. Approach the north wall, then click on it. Place the bamboo pieces in the notches. Click on the golden star. Click the tumi on the golden corn. Take the corn. Place the golden coin in the stamp. Now walk south and you'll reach the anti-chamber of the Founders of Huaca. Turn left and click on the golden panel. Take the third of a star. Click on the mark of a star

to close the panel. Turn two screens left. Click the star on the column. Remove the quipu, then click on the hook. Take the stone star and place it on the mark of a star beneath the golden panel. Place the ear of corn in the golden ball. Click on the arrows until you have one point on the top, two points on the bottom, five points on the left, and three points on the right.

MANCO CAPAC & MAMA OCLLO

Click on the floor. Click on the left statue and a red or blue ball will appear. Immediately after the ball appears, click on the right statue. The balls will combine to create an egg. After creating the first egg, you need to create another egg of the opposite color. Click on the left statue until the opposite-colored ball appears, then quickly click on the right statue. When both eggs are on the platform, click on the vase.

- 62146145 (save code)
- 85542384 (save code)
- 75546741 (save code)



THE HOLD

Click on the label, then on the barrel. Throw the cork at the rat. Pick up the golden cup. Combine the powder and the label. Place the rolled label next to the barrel. Plug the hole of the barrel with the cork. Pull the left chain twice. Reflect the light with the golden plate. Once you're free of the chains, search the barrels in the current room. Take the gold nuggets and the key from the barrels, then close the barrel lid. Enter the adjoining room and search the barrels.

Hint: *Don't open the west door. If you do, you'll perish.*

Take the precious stones and the key from the barrels. Use the key to open the cupboard to the left of the barrels. Take the toiletry bag and the hatchet. Close the cupboard and enter the adjoining room. Use the hatchet on the lid of the barrel containing gun powder. Place the lid in inventory. Place the toiletry bag on the ground and fill it with powder using the plate. Take the full bag into the adjoining

room. Open the east cupboard and place the toiletry bag on the plank. Take the cannon sponge. Enter the adjoining room and click the cannon sponge on the barrel containing gun powder. Click on the trap.

- 68566383 (save code)

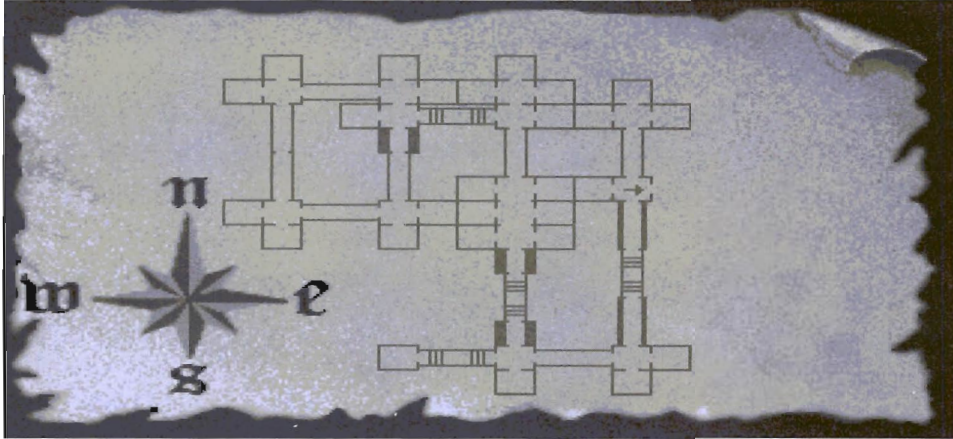

When you reach the double doors containing golden rings, click on the rings until a pair of golden arms appear. Take the candelabra and the crucifix. Place the gold and the precious stones in the golden hands.

THE CLOUD SCENE

Place the candelabra on the pedestal. Remove the center candle. Click the crucifix on the shell. Remove the censor from the shell and place it atop the pedestal. Fill the cup with holy water. Click the candle on the censor. Click the holy water on St. Peter and take his key. Click the key on the door. To solve the cube puzzle, click on the squares in the following order:

- Top-Bottom-Left-Right

- 25186742 (save code)
- 74146144 (save code)
- 14142142 (save code)
- 24564877 (save code)



TEMPLE DOOR

Click on the sun markings from top to bottom. Place the sacred eggs in inventory. Click on the lower-right plaque, then on the upper-left plaque. Quickly place the green egg in the flashing eye. Click on the lower-left and upper-right plaques. Place the red egg in the flashing eye. Push the two middle plaques and place the remaining egg in the flashing eye. Grab the golden dish and click it on the sun carvings from top to bottom.

THE LAVA PIT

Head west through the maze and you'll reach molten lava. Remove the Tumi's blades and place them in inventory. Slide the quarry stones until a beam of light appears. Place the golden sun on the stone. Take the crystal. Remove the golden sun and place the Tumi's blades on the stone. Place the crystal on the stone. The crystals in the upper-right corner of the screen will flash different colors. Jot down the colors, then refer to the code below:

- Blue = Yellow
- Red = Purple
- Green = Green

Click on the colored beams of light using the code above and rocks will fall from the ceiling with each correct entry.

Hint: Here's an example: If the randomly generated crystals change from red to blue, click on purple and yellow.

Continue this procedure until a door opens along the back wall. Walk through the maze in search of bamboo. Once you've found the bamboo, you can enter the dial room.

THE DIAL ROOM

The Dial Room is beyond the door containing bamboo. The trick is to move the stones so that only one remains in the bottom hole. Numbering the stones from

INCA

one to eight, where one is the bottom stone, the answer is:

5,7 3,5 8,6 2,8 5,7 7,1

Begin by moving stone No. 5 to space 7 (space 7 being the empty slot), stone 3 to space 5, and so on. Then click on the center dial until the remaining stone's on top. Click the sun stone on the sun indentation. Take the ruby and the disk.

HALL OF SEASONS

Refer to the following sequence to gain the title of Inca:

- Use the green jewel on the Supreme Star, turning the room green
 - Use the blue jewel on the Supreme Star
 - Use the bamboo on the alluvium
 - Use the red jewel on the Supreme Star
 - Use the green jewel on the Supreme Star until the room is blue
 - Use the bamboo on the water
 - Use the golden sun on the bamboo
 - Use the green jewel on the Supreme Star until the room is green
 - Use the red jewel on the Supreme Star
 - Use the green jewel on the Supreme Star, turning the room yellow
- 52118877 (save code)

Now prepare for the most difficult arcade sequence of the game.

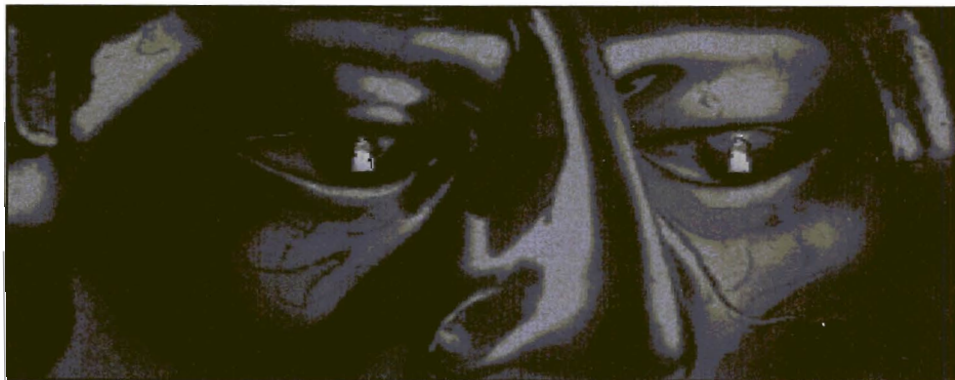

CHAPTER 31

GOBLIINS 2

GRAPHICS:	☆☆	STORY LINE:	☆
ARCADE:	☆☆	INTERFACE:	☆☆☆
DIALOGUE:	☆	AUDIO:	☆☆☆
ANIMATION:	☆☆☆☆	LENGTH:	☆☆☆
OVERALL ANALYSIS: ☆☆☆			

SYSTEMS

- MS-DOS IBM-PC/Tandy & Compatibles

FEATURES

- Simultaneous multi-character mouse control.*
- Highly animated characters with hilarious and often unpredictable personalities*
- Humorous sound effects and lively background music.*
- Seven brain-busting episodes, each with up to five interconnected scenes.*



SCENARIO

Two imps with serious attitude disorders are called out to rescue Prince Buffoon. These insipid goblins never die, and, if kept waiting too long, will show definite signs of impatience by whistling asinine tunes and performing extravagant aerobatics. *Goblins 2*, produced by Coktel Vision (a division of Sierra, creators of *Inca* and *The Prophecy*), provides a sequel to the fatuous first quest made up of single-screen puzzle-solving. The teamwork between you, Winkle, and Fingus is vital to game completion. Don't be fooled into thinking this game is made up of basal characteristics—if you can get through this adventure without the need of this book or any other outside assistance, I must knight thee King of Goblinitiy.

WALK-THROUGH

TOWN SQUARE

Maneuver Fingus near the bottle behind the old men. Click Winkle on the sausage, then have Fingus snatch the empty bottle.

THE FOUNTAIN

Use Fingus on the fountain while Winkle collects water in the bottle. Have Winkle use the bottle on the toad, then take the stone.

THE WIZARD'S HOME

Have Fingus use the stone on the mechanism. After Winkle joins Fingus, use Fingus on the rung and Winkle can climb on the roof. Use Fingus on the door and have him speak to the Wizard. Click Winkle on the chimney repeatedly—eventually he'll get in. On entry, have Winkle step on the animal's tail while Fingus snatches the matchbook from its mouth. Use the matches and then the bottle on the kettle. After the steam loosens the poster, click on the kettle (to extinguish the flames) and seize the spring key. Use the spring key on the cuckoo clock and have Winkle throw the stone at the big key. Use the big key to unlock the cellar door (near fountain) and take the bottle of wine.

TOWN SQUARE: VISIT 2

Use the full bottle of water on the flowers. Click a flower on the Notable and he'll fall asleep. Have Winkle step on the platform while Fingus activates the switch. With Winkle on the roof, he has access to the sausage.

THE GIANT

You need to procure an egg from the chicken. To get the embryonic form, have Winkle tickle the bird while Fingus clobbers it over the head with the sausage. To get past the hound, use the sausage on the pothole. While the dog is dazed, have Winkle sneak by. Now have Winkle climb into the tree hole and a burrow will appear. Use the matches on the woodpile and place the egg over the flames. Give the Giant a swig of wine and a sausage to fill his belly.

THE TRENCH

Deal with the metal guard first. Have Fingus enter the tower, then position Winkle next to the bomb. Use Fingus on the bomb and Winkle to ignite the fuse. Talk to Soka. To get the flying carpet, have Winkle enter the tower. Use Fingus on the bomb and Winkle to light the fuse. Have Fingus get another bomb. Use Winkle on the bomb and Fingus to light it. Step on the carpet.

SANDS OF TIME

Use Fingus and the stone to loosen the basketball. After the little brat filches the basketball, have Winkle enter the tyke's house (below clock). Make Fingus enter the upper-right house and catch the kid by the collar (timing's crucial). Once Fingus has possession of the ball, use the ball on the basketball player. When the player releases the ball, use Winkle on the basket and the ball will bounce off Winkle's head and into the Mayor's house. Talk to the Mayor, then to Tom. Before Tom will give you an hourglass, you must find a melody. Travel to Kael.

KAEL

Use the bottle on Kael. Have Fingus climb on Kael's hand. Maneuver Winkle over the rock near Kael's hand. Use Fingus on the branch. Repeat this procedure while switching characters. Once Fingus has the flower, use the flower on the stone. Click on the stone again and a bee will give Fingus honey. Have Fingus climb on the left rock and use Winkle on the stone. Use Fingus on the bee and it'll carry him to the tree branch. Have Winkle use the bottle on the nymph. Give the nymph the honey and it'll point to a mushroom. Have Winkle present this mushroom to Vivalzart.

VIVALZART

Have Winkle take a worm from the jar. Maneuver Fingus over the platform (directly below the vulture). Have Winkle push the switch to raise the platform. Now, while Fingus is dangling from the perch, have Winkle throw the worm at the vulture. Use the meat on the piranha. Get the bone, then talk to Vivalzart. Have Winkle place the mushroom into the machine (bowl) and have Fingus activate the machine. Maneuver Fingus atop the garbage can, then have Winkle give the bone to Vivalzart. Grab the elixir of kindness and the clothes pin. Using the bottle, have Winkle and Fingus drink the potion from the container.

THE MUSICIANS

Use Winkle on the headlight to obtain a drumstick. To construct a makeshift net, use the drumstick on the stocking cap. While Fingus is bouncing on the spring, use Winkle on the headlight to get the bicycle pump. Have Fingus climb into the left hole—this will place him above the saxophone player. Have Winkle use the pump on the saxophone player. Have Fingus catch the mosquito with the net. Now have Winkle use the mosquito on the headlight to make the drummer perform. Have Fingus catch the note using the net. Have Winkle climb atop the spring without activating it. Use Fingus on the spring. While both goblins are bouncing up and down, a door will open near the west side of the screen. Use Winkle on the hole and have Fingus place the clothes pin on the base of the hose. Position Fingus above the saxophone player and click Winkle on the guitar player. Catch the note using the net. Now have Fingus pump up the saxophone player using the bicycle pump. Have Winkle catch the final note of the melody. Place the melody in the middle house, on the lower level, and talk to Tom, obtaining the hourglass. Use the hourglass on the trench.

THE GUARDS

Get the mayonnaise. Place the mayonnaise next to Gromelon (below skull). Have Winkle stand near Gromelon's sword. Have Fingus climb on the platform (near skull), then jump onto the mayonnaise. While Gromelon is being doused by the mayonnaise, have Winkle snatch his sword. Use Winkle on Rustik and have Fingus snatch the gum from Stalopicus. Grab the mayonnaise, then use the gum on the cupboard to get the imprint.

THE FORGE

Give the imprint and the sword to the blacksmith. Take the stool and have Winkle use it on Otto. Then quickly click Fingus on the lance. Now you can have Fingus jump on the bellows. Get the key from the blacksmith. Have Winkle use the mayonnaise on Focus and, at the same time, have Fingus use the stool to get the meat from Focus. Grab the anvil and travel to the guards. Use the key on the cupboard and use both goblins on the cupboard—each will obtain a diving suit. Use the meat on Amidal to get his false teeth.

THE WELL

Use Winkle on the tunnel to reveal a secret door in the dinosaur. Have Winkle lift the hatchet while Fingus pushes the switch. Immediately after Fingus enters the tunnel, (to activate the dinosaur's jaws) have Winkle enter the dinosaur. While Schwarzy is hypnotized, quickly have Fingus use the stool on the hoist. Have Winkle use the false teeth to spook Schwarzy, then drop the anvil on him. Use the diving suits to enter the well.

THE SHIPWRECK & MERMAID

Have Winkle walk through the center door to knock the skull loose. Have Winkle climb atop the mast. Use Fingus on the lantern and have Winkle catch the lamp fish. Use the lamp fish in the northeast cave. Now travel to the mermaid scene. Have Fingus climb the staircase, near the octopus, and slip through the hole. Use Winkle on the shell and have Fingus catch it. Have Fingus enter the cavity (via the stool and sea horse) and allow Winkle to drop the shell on the glove. Use Winkle to retrieve the glove and the starfish (under shell). Have Fingus use the glove on the blob, then click Fingus on the bottle to obtain a parchment. Use the parchment on the octopus and he'll partially open the passageway. Use Winkle on the bottle and take the pearl. Give the pearl to the mermaid. Take the glove and the stool and return to the shipwreck. Position Fingus on top of the large oyster. Use Winkle on the lantern, then quickly use Winkle on the rudder: This will raise Fingus to the upper deck. Have Winkle open the chest using the starfish and have Fingus touch the statue, then grab the sword from the treasure chest (you may need to do this a few times). Use the sword on the skull and take the diamond. Present the diamond to the mermaid. Take the stool and vamoose.

THE STOREROOM

Click Fingus on the swordfish to get the salt shaker. Use Fingus on the cover of the pot and have Winkle pour salt on the *fellow*. Take the file from the pots. Have Winkle pull the left rope while Fingus holds onto the right rope: This will lift Fingus to Colibrius. Use the file on the chain. Get a thumbtack, then save the game. After obtaining the pepper from the Throne Room, position Fingus above the cook (near shelves). Have Winkle sprinkle pepper on the meatballs, then move Winkle behind the cook. When Oumkapok grabs the cook by the throat, make Winkle place a thumbtack on the crate the cook was sitting on. Quickly

have Fingus pour elixir of kindness on the meatball while it's airborne.

THE THRONE ROOM

To reach the cornice, have Winkle use the stool and make Fingus climb on Winkle's hands. Now use Fingus on the switch and Winkle on the small round door. To obtain Amoniak's crown, have Fingus pull the tongue while Winkle walks into the ear. To catch the first cockroach, use Winkle on the tongue while Fingus enters the ear. Use Winkle on the orifice and Fingus (wearing glove) on the right hole. Place the cockroach on the shelf of the hole and pour elixir of kindness over it. Capture another cockroach before heading toward the Armor Room.

THE ARMOR ROOM

Click on the loose stone (on tower), then click on the helmet twice. Use the crown on the king to restore him to full size. Take the feather from the crown. Dip the feather into the paint can. Click the cockroach on the hole. Now you must make the cockroach look like a ladybug. Do this by painting it with the brush (feather), sprinkling some pepper on it, and dousing it in kind elixir. Travel to the Throne Room and click on Prince Buffoon. Go to the Armor Room and use Buffoon on the machine to shrink the goblins.

THE DESK

After both goblins move the knife twice, have Fingus snatch the bookmark and use it as a candle wick. Use Winkle and the match to pry the skull's eye free. Use Buffoon on the eye and grab the glass shard. Have Fingus use the shard on the ray and place the wax into the seal. Use the imprint on the keyhole and the seed on the village of the map. The plant is your escape route.

KAEL: VISIT 2

Forget about the catapult until later in the game. Use Winkle on the hole to get the bean. Position Winkle slightly east of the stone and Fingus to the west of the stone. Save the game. Click Winkle on the stone, then give the bean to the mole. With lightning speed, click on Fingus to snatch the mole's cap. Have Winkle use the match on the apples and Fingus to catch the apple in the cap. Use Winkle and

GOBLINS 2

the apple on the hole. Devour a few mushrooms.

BUFFOON'S DREAM

This is a tough one! Use Fingus on the bowling pins while Winkle leaps from the star to capture the bowling ball. Place Winkle and the bowling ball on the left box lid. Use Fingus on the right flagstone. After the safety pin lands on the umbrella, get another bowling ball. Place the ball on the box lid and Winkle on the catapult. Use Fingus on the flagstone. Save the game, because the next sequence requires precise timing. Use Winkle on the feeler, then have him climb atop the bubble. Just before the bubble lands on the lid, have Fingus activate the flagstone. After Winkle has the safety pin, place another bowling ball on the lid and have Winkle stand on the catapult. Use Fingus on the flagstone. Now have Fingus stand on the flagstone at the rainbow's end and use Winkle on the upper flagstone. Use Winkle on the switch and, when Buffoon is in the bubble maker, click Fingus on the feeler. Have Winkle burst the bubble with the safety pin. When the scene changes to Kael, use Winkle on the switch while Buffoon is on the lower half of the catapult. When the key appears, click Fingus on the catapult. A door will appear at the rear of the screen.

THE GIANT

Using both goblins, move the stone to the third platform. Place Winkle on the lion head and use Fingus on the stone: Winkle will land on the Giant's right shoulder. Click on the head. Have the goblins hoist the stone to the second level. Place Winkle on the lion head and use Fingus on the stone. Click Winkle on the shoulder hole. Place Fingus on the lion head and click Winkle on the head. When Fingus is on the levitating rock, locate the rock's center of gravity (exclamation points). As Fingus jumps, the rock will descend, allowing Winkle to climb on it. Save the game. Click Winkle on the small rock and quickly have Fingus walk across Winkle's body. Use the file on the cage and grab the key. Travel to the plant via the travel icon and use the key on the door.

THE LAB

Use the fountain water on Buffoon. Have Winkle use the pencil on the blackboard three times. Get the sponge. Have Fingus use the pencil on the portrait, then have Winkle leap onto the armchair to seize the boomerang.

Position Fingus in the center of the room. Have Winkle use the mug on Tazaar. Have Fingus fling the boomerang toward the toothpick (before it bounces off the screen). Have Winkle use the toothpick on the skeleton. Use the sponge on the puddle. Use Winkle on the pipe and have Fingus use the wet sponge on the smoke.

AMONIAK

Hint: The following sequence is extremely time-sensitive.

Position Fingus over the right eyeball. Have Winkle jump from the upper-right platform (exclamation points). Grab the mouse. Have Winkle use the mouse on the mud, then walk on the crocodile. Immediately after Winkle lands on the upper platform, Amoniak will extend his arm. Have Winkle hurl the boomerang at the *teeth*, then have him jump off the platform (exclamation points). Once Buffoon is free, position Buffoon over the right eyeball. Place the wet sponge on the rock. Position Fingus near the rock. Have Winkle jump from the platform. And, as the water is dripping down the rock, have Fingus use the pencil on the rock. Use Winkle on the handle and you're home free.



CHAPTER 32

LOST SECRET OF THE RAINFOREST

GRAPHICS:	☆☆☆	STORY LINE:	☆☆☆☆
ARCADE:	N/A	INTERFACE:	☆☆☆☆
DIALOGUE:	☆☆☆	AUDIO:	☆☆☆
ANIMATION:	☆☆☆☆	LENGTH:	☆☆☆
OVERALL ANALYSIS: ☆☆☆☆			

SYSTEMS

- MS-DOS IBM-PC/Tandy & Compatibles

FEATURES

- An entertaining, educational, science learning adventure for kids ages 10 and up.*
- Created with the assistance of leading environmental organizations.*
- Extensive educational value covering botany, zoology, and anthropology.*
- On-screen "Ecoder" reveals, records, and prints out information about the plants, animals, and native peoples you discover.*
- You'll learn: forest life forms, native cultures, reading for meaning, problem-solving, logical thinking, and much more.*



SCENARIO

After rescuing the mighty whale Cetus from the deadly denizens of the deep, Adam's back and ready to save the earth—again. This time he treks through a wondrous milieu of dense jungles, ancient ruins, and mysterious bat caves deep within the delicate ecosystem of the South American rain forest. *Lost Secret of the Rainforest* by Sierra On-Line is a unique game that teaches children about our frail ecosystem in a fun and interesting way. With scientifically accurate information, the would-be taxonomist will acquire knowledge about dozens of endangered species, rare flora, and remote native cultures. Sierra has proven that learning can be fun! If you enjoy this adventure, be sure to check out *EcoQuest: The Search for Cetus*, also by Sierra.

WALK-THROUGH

CUSTOMS

Welcome to the rain forest. Begin by clicking on inventory and opening your U.S. passport. Click the *open* passport on the customs official. Look at the man holding a sign, then talk to him. Walk one screen east. Eavesdrop on the two men by clicking the hand cursor on the crates. Click on the net. When the bird-peddler appears, purchase the exotic creature. Walk one screen west and open the package. Walk one screen east and use the Ecoder on the launch, spewing gasoline into the river. Walk one screen west.

MORPHEUA AND ORPHEUS

After a short animated sequence, talk to Orpheus twice. Take the necklace. Use the Ecoder on everything in the scene. Clean up the debris using the garbage bag icon. Take the sticky leaf, then walk one screen east.

THE EMERGENT TREE

After using the Ecoder on everything, use the sticky leaf on Adam—this will repel the insects. Ascend the tree.

THE TOUCANS' NEST

Use the Ecoder, then talk to all three toucans. Also, be sure to talk to every creature you meet for additional game points. Walk one limb west and use the Ecoder. Talk to the darter (black bird). Pick a purple perfume flower. Walk one limb east, then one screen north. Use the Ecoder, then talk to the tree creatures. To extinguish the fire in the toucans' nest, you must reach—and click on—the second group of pitcher plants. To reach them, use the perfume flower on Adam. Walk one screen south and speak to the toucans. Walk two screens west via the upper tree limb.



THE VILLAGE

After using the Ecoder, grab the vine and the squashed fruit. Throw the fruit near the center of the screen and lasso the pig with the vine. Walk one screen east and place the wooden drum on the drum stand. Refer to the symbols on the hide to play the correct melody. Take the drum. Walk one screen west and one screen north. Enter the first path. Place the drum on the drum stand and play the same melody you played earlier. Take the drum.

**FOREST HEART**

After using the Ecoder on the seed pods, click the hand cursor on the gnarled roots. Take the fallen branch. Exit the room by walking west. Enter the second path and take the seed pods. Enter the third path and fill the bark cup with sap.

THE GROVE PEOPLE

Talk to the potter and you'll learn that her baby was stung by a bee. To cure the little tyke, walk two screens east and place the bark cup (full of pungent sap) and the seed pods on the shaman's medicine bench. Be sure to talk to the shaman several times. While you're here, give the drum to the little boy. Exit this scene, then return—the poultice will be ready. Give the poultice to the child and the potter will give you a clay pot. Talk to *all* the grove people. Enter the scene with the shaman's hut and use the vine to reach the other side of the river. Grab a handful of red berries and take the potter's lost necklace. Show the necklace to the potter, then give it to the weaver. Take the machete from the chief. Give the machete to Lazy Sumac and she'll give you some roots. Give the roots to Alichina, then hand her the pot (which the potter gave you) and she'll fill it with a sweet drink. To catch the butterfly, walk to the screen with the mud puddle. After the butterfly lands on the bush, place the sweet drink on the ground. Give the butterfly to the shaman, then enter the hut.

THE THATCHER

Sit before the thatcher. To get Quiri off the paint pot, use the sticky leaf to fix the

LOST SECRET OF THE RAINFOREST

leaky roof. Place the berries in the bowl. Refer to the game documentation to pass the off-disk copy protection sequence. Give the green bough (branch) to the thatcher and grab the golden blossom. Talk to the bat, then show her the amulet.

SLAUGHTER'S HUT

Click the hand cursor on the cage, then enter the bedroom. Click on the tiger's tail and grab the note. Take the fax transmission. Open the footlocker and grab the tennis racket. Take both bed sheets and the personal organizer. Use the organizer by depressing the button containing a key (the password can be found on the note):

RETHGUALS

The combination to the safe is:

582

After removing and examining the safe's contents (your stuff, a bird cage key, a wallet, a gold mask, and a letter), click on the tiger and use the bed sheets to escape. Save the game.

SLAUGHTER GROUNDS

The object is to complete the following tasks without getting caught by Gonzales. Hide behind the barrels as you approach the rickety platform. When Gonzales walks one screen east, climb the tower and immediately turn off the alarm.

Hint: Turn off the security system.

Take the suspenders and the Crudsucker. Use the suspenders on the dish to get down. Use the Crudsucker on the spilled grain. Hustle to the north barrel and walk one screen east while avoiding Gonzales. Wait for Gonzales to leave this screen, then remove the grain from the Crudsucker. Give the grain to the birds,

then use the small key on the left bird cage. Take the axe and use it on the large log to construct a canoe. Use the tennis racket as an oar.

THE BAT CAVE

Show the bat on the right the amulet. Grab the visas. Pass out the visas by first talking to the bats, then use the trial-and-error method, or the Ecoder. Give your visa to the bat and exit the bat cave.

GUARDIAN OF THE TEMPLE

Click on the stone rod and speak to Chiropterus. Pick up the Truth Stone and place it on the southwest tip of the jaguar's platform. After answering the jaguar's simple questions, grab the golden feather and walk north. When Paquita falls ill, seek help from Chiropterus. Use the whistle.



THE FLOODWATERS

Swim south and grab the fruit. Swim one screen north and talk to the howler monkey. Give him the fruit and he'll allow you to climb on the isle. Grab the piranha jawbone and swim one screen west and one screen south. Use the jaws to obtain a lily pad. Return to the howler monkey and give him the lily pad.

ROYAL ROOST

Give the golden feather to the harpy eagle.

THE HILLTOP

Use the garbage bag to clean up the debris. Take the magnifying glass found under a piece of garbage. Place the gold mask in the deep gouge. Place the pile of gold and the heavy round object (which is in your inventory) on the oddly shaped rock.

THE RUINS

To get to the room near the back of the ruins, click on inventory and use the magnifying glass on the intricately carved necklace. Then enter the right doorway and follow the outer path (walking behind the room). Follow this path until you walk behind the room again, and you're in. Two pictures must be created on the blocks of stone. Click on them while keeping an eye on the border. After creating both pictures, you'll obtain a golden crown, a tiny pot of gold dust, and a pair of ancient pipes. Use the footholds and the serpent's tail to open the door.

THE SERPENT

Use the stepping stones while avoiding the one on the left. Use the crown and the pipes on Adam to elude the serpent. Swim toward the isle.

THE FOUNTAIN

Remove the stone cup from the statue and place it on the fountain. Click on the small pillar and you'll be captured by the vines. Click the amulet on Adam. Click on the pillar again. Place the yellow blossom in the cup. Grab the Seedling of Forest Heart. After Slaughter arrives, place the cup of gold dust on the fountain. Blow the whistle to summon the bats. Give Paquita water from the fountain. After your journey, plant the seedling.



LOCATION OF OBJECTS

- Amulet Orpheus
- Ancient Pipes Ruins
- Axe Slaughter Grounds
- Bark Cup Forest Heart
- Bed Sheets Slaughter's Hut
- Bird Cage Key Slaughter's Safe
- Butterfly Mud Puddle
- Crudsucker Rickety Platform
- Ecoder Adam's Father
- Fallen Branch Forest Heart
- Fax Transmission Fax Machine (Slaughter's Hut)
- Fruit Floodwaters
- Gold Dust Ruins
- Gold Mask Slaughter's Safe
- Golden Blossom The Thatcher
- Golden Crown Ruins
- Golden Feather Jaguar
- Grain Spilled Bag (Slaughter Grounds)
- Intricately Carved Necklace The Weaver
- Letter Slaughter's Safe
- Lily Pad Floodwaters
- Machete The Chief
- Magnifying Glass Below Trash (Hilltop)
- Note Tiger's Mouth (Slaughter's Hut)
- Perfume Flower Emergent Tree
- Personal Organizer Slaughter's Hut (Below Bed sheets)
- Pile of Gold The Hilltop
- Piranha Jawbone Howler Monkey
- Potter's Necklace Across River
- Poultice Medicine Bench (Shaman's Hut)
- Red Berries Across River
- Roots Sumac

LOST SECRET OF THE RAINFOREST

- Sap Forest Heart
- Seed Pods Forest Heart
- Seedling of Forest Heart Fountain
- Squashed Fruit Mud Puddle
- Sticky Leaf Near Orpheus
- Stone Cup Fountain Statue
- Suspenders Rickety Platform
- Sweet Drink Alichina
- Tennis Racket Footlocker (Slaughter's Hut)
- Vine Mud Puddle
- Visas Bat Cage
- Whistle Chiropterus

CHAPTER 33

THE 7TH GUEST

GRAPHICS:	☆☆☆☆	STORY LINE:	☆☆☆☆
ARCADE:	N/A	INTERFACE:	☆☆☆☆
DIALOGUE:	☆☆☆☆	AUDIO:	☆☆☆☆
ANIMATION:	☆☆☆☆	LENGTH:	☆☆☆☆
OVERALL ANALYSIS: ☆☆☆☆			

SYSTEMS

- MS-DOS IBM-PC/Tandy & Compatibles
- CD-ROM & Soundcard required

FEATURES

- The first interactive drama in a terrifying real virtual environment, complete with live actors.*
- Old Man Stauff's bizarre puzzles to solve and games to play.*
- 22 rooms to explore in a fully 3-D haunted mansion with ghastly surprises lurking in every shadow.*



SCENARIO

On the crest of a hill stands The Stauf Mansion, an edifice haunted by six ghastly ghosts for as long as anyone can remember. Stauf, the evil toymaker, filled his mansion with intriguing puzzles and witty games for you to solve and enjoy. Trilobyte has ventured well beyond current technology in creating Matthew Costello's interactive drama *The 7th Guest*—the first CD-ROM-based interactive adventure game to incorporate 3-D graphics, speech, live video action, and Morph renderings (as seen in *Terminator 2*, *Star Trek 6*, and Michael Jackson's "Black or White" video). Prepare to promenade through 22 eerie rooms (all high-resolution), observe apparitions as they mysteriously appear and disappear, and tackle dozens of puzzles and games in this mind-blowing Interactive drama. *T7G* packs so much information it could fill more than 3000 conventional floppy disks! How'd they do it? By distributing the game on not just one but two compact discs (and if you pop disc No. 2 in your stereo CD player, you've got the entire musical score blaring through your home speakers). Also included with the game is a VHS tape entitled *The Making of The 7th Guest*. To sum it up, *T7G* is my favorite adventure game to date—and I've played hundreds! Therefore, I'm proud to rate it as my personal *Best Computer Game of the Year!* Your bottom jaw will strike the floor from the opening screen—I guarantee it!

WALK-THROUGH



TELESCOPE PUZZLE (LIBRARY)

The object of this puzzle is to click on the letters, beginning with the letter *T*, to spell a sentence.

Answer: *There is no possible way*

CAKE PUZZLE (DINING ROOM)

The object of this puzzle is to divide the cake into equal portions. Each portion must consist of two skulls, two tombstones, and one plain piece. See next page.

THE 7TH GUEST

□ Answer:

29	28	27	26	14	13
30	23	24	25	15	12
21	22	19	20	10	11
16	17	18	9	8	7
1	2	3	4	5	6

HEART MAZE (BEDROOM)

The object of this puzzle is to position the valves so that the blood has a clear path to the other side. To make the blood flow, click on the heart.

□ Answer:

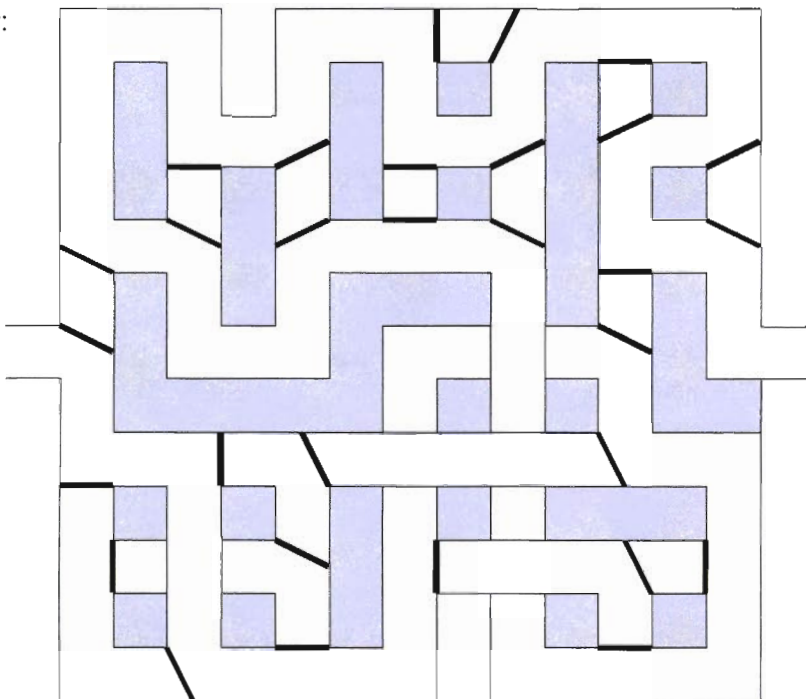

CHESSBOARD PUZZLE (GAME ROOM)

The object of this puzzle is to place eight Queens on the board. The catch: They must be positioned so that none of them can be captured using basic Queen moves.

Answer:

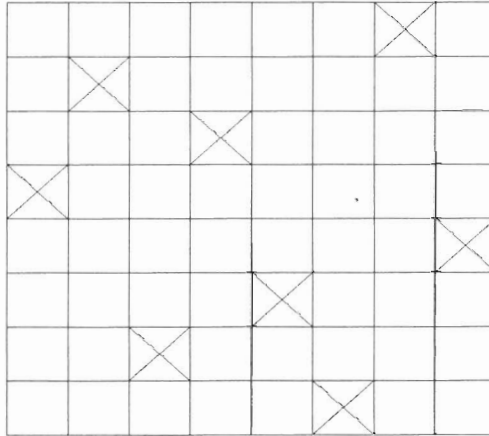
**THE BISHOP PUZZLE (BEDROOM)**

The object of this puzzle is to use standard Bishop moves to maneuver the white pieces to the black side and the black pieces to the white side.

Answer: To solve this puzzle, it's easiest to use the book on the table in the library three times (trust me on this one).

FLOWER PUZZLE (BEDROOM)

The object of this puzzle is to click on the lettered flowers to spell a sentence. Be sure to separate the words with asterisks.

Answer: *The*sky*is*ruddy*your*fate*is*bloody*

THE 7TH GUEST

STAINED GLASS PUZZLE (FOYER)

The object of this puzzle is to click on the purple circles so that seven spiders appear on the glass.

- Answer: NE-S/E-NW/SW-E/W-NE/N-SW/SE-W/N-SE

CAN PUZZLE (KITCHEN)

The object of this puzzle is to move the cans to spell a sentence.

Hint: Bashful nomad, craftily, agilely meet secretly near my underground vault.

- Answer: *Shy Gypsy Slyly Spryly Tryst By My Crypt*

GRATE PUZZLE (KITCHEN)

The object of this puzzle is to slide the grates until you have an opening.

- Answer:

1	2	3
4	5	6

3-6-5-4-1-2-3-6-5-4-1-2-5-4-1-2-5-4-1-2-3-6-5-4-1-2-5-4-1-2-3-6-5

THE MAZE

Continue due north until you reach the 10th junction, then go east. Go *past* the next junction to reach the *T*, then go east. When you reach the next junction, go east. When you reach the next junction, go east, then west. At the next junction go east. Go *past* the next junction then—at the next junction—go east, then west.

COFFIN PUZZLE (CRYPT)

Because the game shuffles the opening sequence, you must use the trial-and-error method to close all the lids. If you don't like the opening configuration, you can rescrumble the puzzle by clicking on the lower portion of the screen. Symmetry plays a key role in solving this puzzle.

KNIGHT PUZZLE (BATHROOM)

The object of this puzzle is to use basic Knight moves to maneuver the black pieces to the white side and the white pieces to the black side.

□ Answer:

A	B	C	D	E
F	G	H	I	J
K	L	M	N	O
P	Q	R	S	T
U	V	W	X	Y

B-I-L-S-H-O-D-G-N-C-J-M-X-Q-F-M-D-G-R-U-L-A-H-E-N-Y-R-K-V-M-T-I-L-W-P-G-D-M-X-Q-N-W-T-M

CARD PUZZLE (BEDROOM)

The object of this puzzle is to flip *all* the cards over.

□ Answer 1:

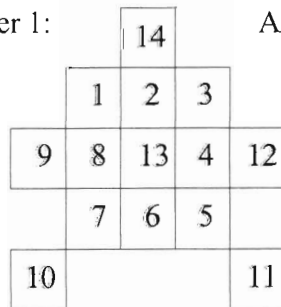

Answer 2:

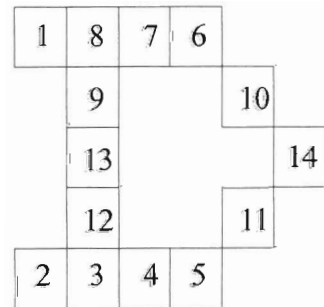

COIN PUZZLE (BEDROOM)

This puzzle is similar to the card puzzle; you must turn over *all* the coins.

□ Answer 1:

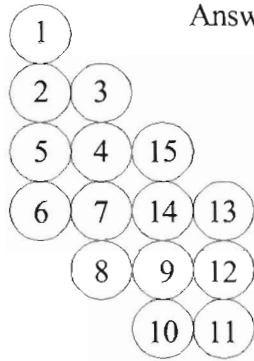

Answer 2:

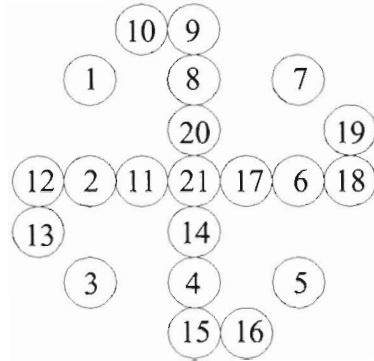

TILE PUZZLE (ALTAR)

The object of this puzzle still bewilders me, so my wife figured it out ...

□ Answer:

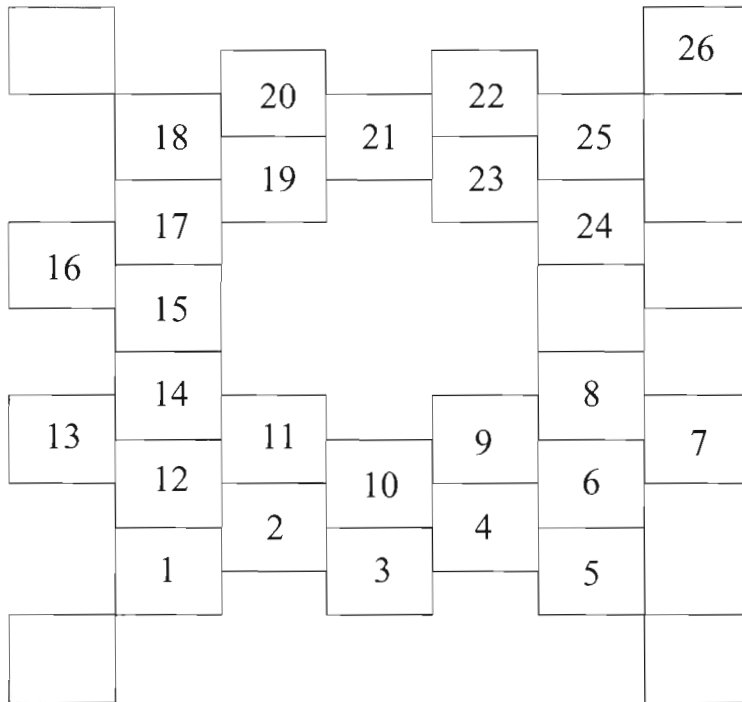

MICROSCOPE PUZZLE (LABORATORY)

Well folks, because of random generation you're on your own—except for some helpful hints. The object of this game is to outnumber the green “virus” blood cells with your blue “healthy” blood cells. Do so by placing a blue cell in an empty hole (if you jump over a hole, your cell won't replicate). To cure the virus, you must land next to as many green cells as possible. Once you land next to a green cell, your blue cell will multiply—overtaking the green cell(s). Therefore, try to land next to three green cells at all times. Good luck!

STAUFWAY PIANO PUZZLE (MUSIC ROOM)

After mysteriously transporting through the foyer floor, you'll find the music room. Memorize the notes, then play them back. Be forewarned, however: If you miss a single note, the puzzle will recycle itself and you must start over (grrr).

□ Answer: B/^B/F#/G/E/D#/E/F#/E/B/^B/^C/^B/A/G/F#/E/F#

MASTER GALLERY PUZZLE

Again, because of random generation, you're on your own. This one isn't too tough—you must create any of the three personalities of Stauf (i.e., red, green, flesh). The squares change adjacent squares, but not diagonal ones.

TOY PUZZLE (TOY ROOM)

Flip the letters to create three words.

□ Answer (from top, down): GET, BOY, TAD

PICTURE PUZZLE (PLAY ROOM)

Random generation again takes its toll. The easiest way to recreate the picture is to flip the squares so that all of them contain the *same* portion of the picture. Then, working from the bottom row up, create the picture.

KNIFE PUZZLE (DOOR TO ATTIC)

The object of this puzzle is to have only one knife remaining in the star. Click on a knife to make it jump over another knife, thus removing that knife.

Answer:

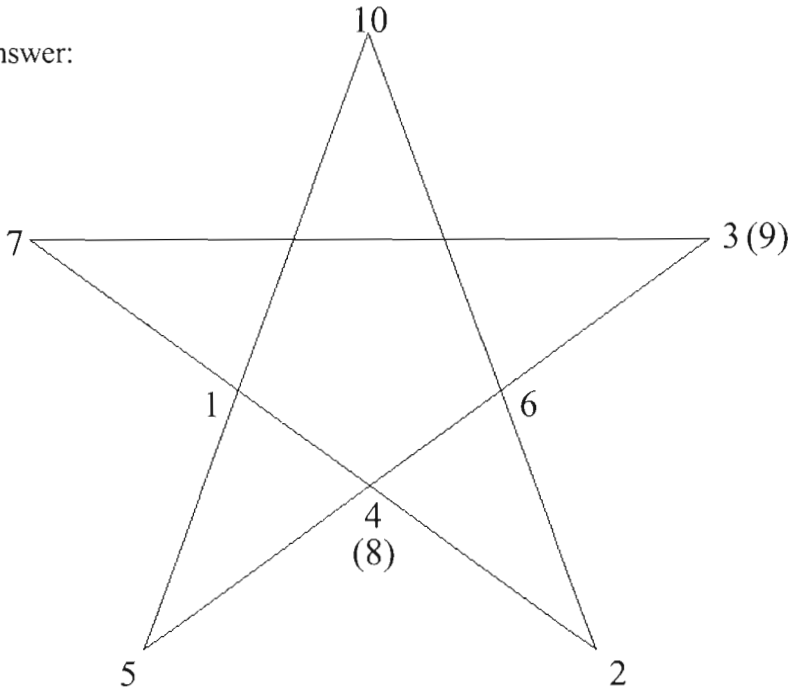

WINDOW PUZZLE (ATTIC)

- Answer No. 1: Click on the following windows:
 - Bottom row, No. 6
 - Second row from bottom, No. 6, No. 7
 - Third row from bottom, No. 7
 - Fourth row from bottom, No. 5

- Answer No. 2: Click on the following window:
 - Bottom row, No. 3

- Answer No. 3: Click on the following window:
 - Bottom row, No. 2

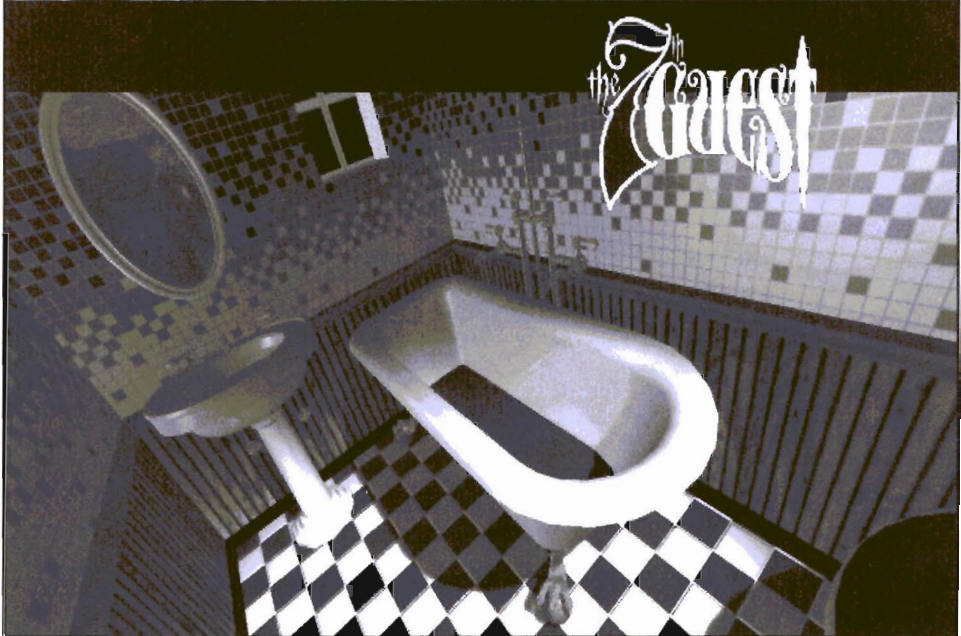

CHAPTER 34

FREDDY PHARKAS

GRAPHICS:	☆☆	STORY LINE:	☆
ARCADE:	☆☆	INTERFACE:	☆☆☆☆
DIALOGUE:	☆	AUDIO:	☆☆
ANIMATION:	☆☆	LENGTH:	☆
OVERALL ANALYSIS: ☆☆			

SYSTEMS

- MS-DOS IBM-PC/Tandy & Compatibles
- Macintosh (no release date given)

FEATURES

- Point-and-click your way through sagebrush, livestock, cacti, buzzards, and swinging saloon doors . . . just like at the movin' pitcher show!*
- Drink your own mistakes from an authentic, working, late 19th-century laboratory!*
- Unlock your hidden potential with your very own copy of The Home Medical Advisor (1881 Edition)!*
- Learn (and quickly forget) the real words to "The Ballad of Freddy Pharkas"!*



SCENARIO

Say, partner, ain't it 'bout time ya polish yer spurs, reload yer six-shooter, and saddle yer horse? The flea-bitten in-breds is 'bout to explode in Coarsegold. If'n ya ain't one heckuva gunslinger, you'd better hide yer hide or it'll be branded by lead fer sure. Now where wuz I? Oh yeah—seein' that ya play the role of Freddy Pharkas, the town's pharmacist (AKA the slickest gunslinger in the Old West), ya must decide whether or not to strap on the Colts, seein' that the once-thriving metropolis is quickly becoming a ghost town. Al Lowe, creator of the *Leisure Suit Larry* series, sprang another leak, which pooled into a new perversion called *Freddy Pharkas: Frontier Pharmacist*, a Sierra On-line adventure/arcade game.

WALK-THROUGH

ACT I: LIVING THE COARSEGOLD DREAM

Enter the saloon and take the whiskey glass from the doctor. After speaking to the saloon's occupants, enter Mom's Cafe and grab the empty bean can. Now enter Pharkas Pharmacy using the key in inventory. Save the game. Walk behind the counter and Penelope will appear:



She'll ask you to fill a prescription. Click the hand cursor on the back door, then on the laboratory shelves. Using the inventory window, examine Penelope's prescription. Refer to page 27 (21) of the game documentation (copy protection).

PENELOPE'S PRESCRIPTION: PEPTICLYMACINE TETAZOLE

Begin by placing the specified amount of Pepticlymacine Tetazole in the graduated cylinder. Place a medicine bottle on the table. Click the cylinder on the medicine bottle. Cork the bottle and give it to Penelope.

HELEN BACK'S PRESCRIPTION: QUINOTRAZATE

Place the specified amount of Bismuth Enterosalicyline into the graduated cylinder. Place the specified amount of Phenodol Oxytriglychlorate on the balance. Combine these ingredients in a beaker and stir the mixture using a clean glass rod. Dispose of the glass rod, then place the mixture into the pill machine. Place 21 pills into a medicine bottle, cork it, and give it to Helen.

MADAME OVAREE'S PRESCRIPTION: ESTROSTERANE

Place the specified amounts of Bimethylquinoline Crystal and Metyraphosphate on the balance. Grind the mixture in the mortar. Use the 5 gm. measuring spatula

to make six medicinal paper packets (5 gm. each). Place these packets in a prescription box and give it to Sadie.

SMITHIE'S PRESCRIPTION: PREPARATION G

This one's easy: You'll find a purple tube of Preparation G on the left-*front* shelving unit.

ACT II: THE PLOT SICKENS

Take a whiff (pewh). Boy, does the air stink! Save the game, since the next section is time-sensitive.

Hint: The following sequence is time-sensitive.



First, you must make a gas mask. And, being the faithful reader that you are, you already have the bean can from Mom's Cafe. Take the alley to reach the back of the saloon. Grab the Elixir and the ice pick. Run to Smithie's Blacksmith and grab the rope, the leather bridle, and an un-

used chunk of charcoal from the forge. Use the ice pick on the bean can. Place the charcoal into the bean can. Click the leather strap on the can, then use the makeshift gas mask periodically during this sequence. Now you must make the horses stop a-fartin'. Begin by entering the general store. Take the complimentary paper bag from the counter. Exit the store and walk one screen east. When the horse raises his tail, collect some purged pungent pressure in the paper bag (timing is crucial). Now you must diagnose the offensive odor to determine the proper treatment for flatulence.

FLATULENCE

Click the Elixir on the alcohol lamp. Light the lamp with a match. Move the gaseous spectroscope in front of the burner and click the bag of horse flatulence on the burner (pray that it doesn't explode). Match the results to those found on page 39 of the game documentation.

PHARKAS'S DEFLATULIZER: AMINOPHYLLIC CITRATE

Place the specified amount of Sodium Bicarbonate on the balance. Place the specified amount of Furachlordone into the graduated cylinder. Combine these chemicals in the beaker. Place the specified amount of water into the beaker (via the graduated cylinder). Now place 5 gm. of Magnesium Sulfate on the balance, then into the beaker. Stir the mixture with a glass rod. Pour the mixture into a medicine bottle and cork it. Click the Deflatulizer on the water trough located in front of Big & Tall.

THE STAMPEDE

To stop the stampede, buy a case of beer from the bartender at the saloon. Head down the alley and locate the church. Open the doors of the church, grab some wax, and click the look cursor on the right door. Take the key. Head west, crossing the rickety bridge. Open the beer bottles using the church key and pour the ale on the railroad tracks.

SRINI

After speaking to Srimi, get the ladder from the school playground and click it on the anthill.

WATER PURIFICATION TREATMENT

If you've walked past the water tower, you know that there's something very wrong with the town's water supply. Save the game, then head to your lab.

BISALICYLATE ANTITOXIDENE

Place the specified amount of Bismuth Subsalicylate and Orphenamethihydride into the test tube. Heat the mixture to a boil. Pour it into a medicine bottle and cork it shut. Now get the ladder from the anthill (and, if you haven't already done

so, get the rope from Smithie's). Save the game, because the following sequence is time-sensitive.

Hint: *The following sequence is time-sensitive.*

Was that Cedric who landed on the covered bridge? Well, there's no time to find out. While ignoring the owl, hustle over to the water tower and click the ladder on it. Click the boot cursor on the ladder to scale the first level. Click the hand cursor on the ladder, then click the ladder on the tank. After climbing partially up the ladder, open the inventory window and click the hand cursor on the rope—this will give you a lasso. Click the lasso on the top of the tank, then scale to the roof. Open the hatch and drop in the purifier.

THE FIRE

Save the game! Grab the bags of baking soda from the porch of the pharmacy. Click the baking soda on the seesaw. Use the swing while clicking on Freddy to swing higher. At the proper moment, click on the schoolhouse roof. Once Freddy's on the roof, have him jump on the seesaw.

HOW TO END ACT II

Go to Freddy's bedroom and grab the claim ticket from the dresser and the desk key from the nightstand. Open the trunk and take the gunslinging outfit. Exit the pharmacy and walk three screens west, one screen south. After eavesdropping on the conversation, enter the bawdyhouse and grab the French postcards from the table. Talk to the flappers and the sheep. Eventually Madame Ovaree will appear, thus ending Act II.

ACT III: GUNS & NEUROSES

Use the key (which you found in the nightstand) to unlock the desk near the laboratory. After unlocking the drawer, grab and read the letter. Exit the pharmacy and gingerly pick up the horse's by-product. Head over to the graveyard and use the shovel to dig up Philip D. Grave's grave. Click the hand

cursor on the grave to retrieve the safe deposit box key. Before leaving the graveyard, grab a handful of clay, then click the shovel on the grave. Travel to the bank and click the safe deposit box key on the clerk. Open the box and remove the revolvers and the red handkerchief. Now give the claim ticket (which you found in Freddy's dresser) to the barber and he'll give you a pair of boots.

ACQUIRING AMMO AND A GUN-CLEANING KIT

Get a cup of coffee from Mom's Cafe and give it to the sheriff. In return, he'll give you some ammo. You can also get a gun-cleaning kit from the sheriff—if, of course, you have an apple pie. To get the pie, place the horse's by-product (which you found lying in the street) on the floor of Mom's Cafe. Then quickly sneak around back and snatch the pie from the window sill. Give the pie to the sheriff and he'll give you a cleaning kit. Clean and load your weapons, then practice shooting the empty beer bottles near the graveyard.

THE SILVER EAR

Begin by grabbing Srimi's medallion from the north wall of the pharmacy. Enter the general store and talk to Willy. Click the medallion on Willy. Now exit and reenter the store. Get Willy's knife and click it on the wax you took from the church. Click the clay (which you took from the gravesite) on the wax ear. Go to the lab and light the alcohol lamp. Place the mold on the lamp. Place the crucible on the table. Place the medallion in the crucible. Melt the medallion by clicking the crucible on the alcohol lamp. Click the empty mold on the crucible, then click the hand cursor on the mold. Now you have a silver ear and you can change into your disguise.

ACT IV: SHOWDOWN AT THE HALLELUJAH CORRAL

Talk to Chester Field, then save the game. Confront Wheaton Hall in the saloon. Do this by clicking the look cursor on the poker table. When you see Hall's third hand, quickly click the hand cursor on it. When Freddy dives behind the table, shoot the bar's footrest—the bullet must ricochet off the footrest and strike the chandelier directly above Hall. Be sure to talk to Mr. Laffer before leaving the saloon via the back door.

THE GUNSLINGERS

To rid the town of the gunslingers, exit the saloon via the back door. Save the game. Now you must enter the barber shop through the back door. So start at the back of the saloon and walk one screen south, one screen east, then south (align Freddy with the water tower spout before walking south). Give the barber the postcards and, in return, he'll give you a bottle of laughing gas. Take the back road to reach the back of the saloon. Go up the stairs and place the nitrous oxide on the railing. Now, while avoiding the cowhands, enter the gazebo near the bawdyhouse. From inside the gazebo, you have a clear shot at the nitrous oxide (look for the red, white, and blue banners). After getting your ear shot off (which is unavoidable), use the handkerchief to stop the bleeding.

PENELOPE

After dropping your weapon by opening the inventory window and clicking the hand cursor on the guns, deflect Penelope's shot with the slate lying on the table next to Freddy. When Freddy's all tied up, click on him to knock over the chair. Get the silver ear and sharpen it on the floor. Use the silver ear to cut the ropes. Finally, grab the sword from the wall and kill Penelope.



LOCATION OF OBJECTS

- Ammo Sheriff
- Baking Soda Pharmacy Porch
- Bean Can Mom's Cafe
- Beer Saloon
- Boots Barber
- Charcoal Smithie's Blacksmith
- Claim Ticket Freddy's Dresser
- Clay Graveyard
- Elixir Behind Saloon
- French Postcards Bawdyhouse
- Gun-Cleaning Kit Sheriff
- Gunslinging Outfit Freddy's Trunk
- Handkerchief Safe Deposit Box
- Horse's By-product Street in Front of Pharmacy
- Ice pick Behind Saloon
- Key 1 Church Door
- Key 2 Freddy's Nightstand
- Key 3 Graveyard
- Knife Willy (General Store)
- Ladder School Playground
- Lasso Made From Rope
- Leather Bridle Smithie's Blacksmith
- Letter Freddy's Desk
- Medallion Pharmacy
- Nitrous Oxide Barber
- Paper Bag General Store
- Pie Behind Mom's Cafe
- Preparation G Front Left Counter (Pharmacy)
- Revolvers Safe Deposit Box
- Rope Smithie's Blacksmith
- Shovel Graveyard
- Wax Church
- Whiskey Glass Saloon

Official Hint Books from Legend Entertainment

Spellcasting 101 The Official Hint Book

Spellcasting 201 The Official Hint Book

Spellcasting 301 The Official Hint Book

_____ Spellcasting 101: Official Hint Book \$9.95 (0-87455-285-3)

_____ Spellcasting 201: Official Hint Book \$9.95 (1-880520-04-4)

_____ Spellcasting 301: Official Hint Book \$9.95 (0-87455-286-9)

_____ **Total**

_____ Tax (Residents of NC, NJ, and NY add appropriate sales tax.)

_____ Shipping and handling (U.S.: \$2.50; Canada: \$4.00;
Foreign: \$6.00 first book, \$1.00 each additional.)

_____ **Grand total**

_____ **Check or Money Order** _____ **MC** _____ **VISA**

Signature _____

(Required)

Acct. No. _____ Exp. Date _____

Name _____

Street Address _____

City _____ State _____ ZIP _____

Send this entire coupon to:

COMPUTE Books
c/o CCC
2500 McClellan Ave.
Pennsauken, NJ 08109

Please allow four to six weeks for delivery. Offer good while supplies last.

All orders must be paid in U.S. funds drawn on a U.S. bank.

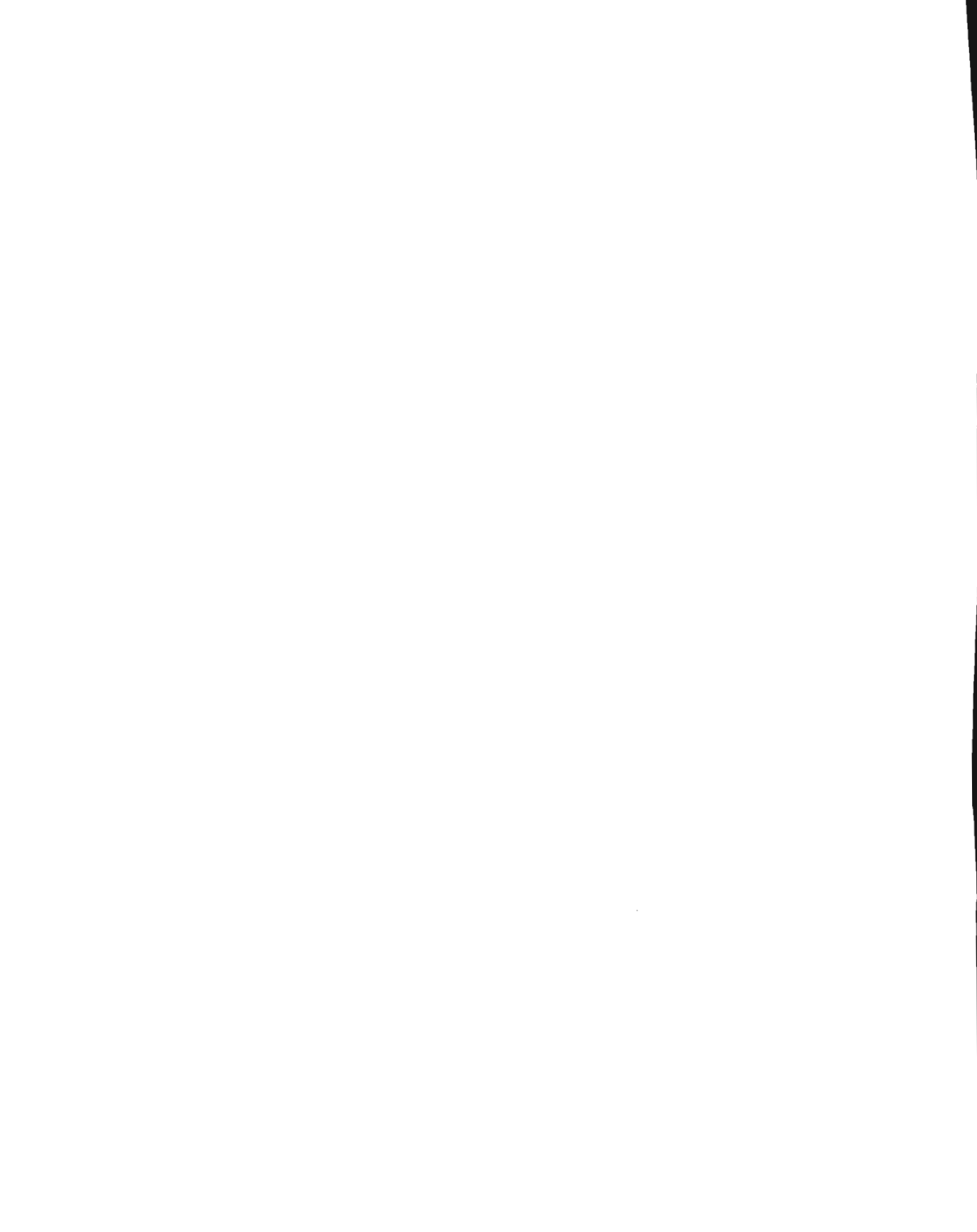

COMPUTE BOOKS HAS THE OFFICIAL GUIDES TO SIERRA® ADVENTURES

_____ The Official Guide to Roger Wilco Space Adventures, 2nd Ed \$16.95 (2818)

_____ The Official Book of Police Quest \$14.95 (2605)

_____ The Official Book of Leisure Suit Larry, 2nd Ed \$14.95 (2567)

_____ The Official Book of King's Quest, 3rd Ed \$16.95 (2745)

_____ **Total**

_____ Tax (Residents of NC, NJ, and NY add appropriate sales tax.)

_____ Shipping and handling (U.S.: \$2.50; Canada: \$4.00;
Foreign: \$6.00 first book, \$1.00 each additional.)

_____ **Grand total**

___ **Check or Money Order** ___ **MC** ___ **VISA**

Signature _____

(Required)

Acct. No. _____ Exp. Date _____

Name _____

Street Address _____

City _____ State _____ ZIP _____

Send this entire coupon to:

COMPUTE Books
c/o CCC
2500 McClellan Ave.
Pennsauken, NJ 08109

Please allow four to six weeks for delivery. Offer good while supplies last
All orders must be paid in U.S. funds drawn on a U.S. bank.

COMPUTE BOOKS HAS THE OFFICIAL GUIDES TO SID MEIER'S SIMULATIONS

_____ The Official Guide to Sid Meier's Railroad Tycoon \$12.95 (2443)

_____ The Official Guide to Sid Meier's Civilization \$14.95 (2591)

_____ **Total**

_____ Tax (Residents of NC, NJ, and NY add appropriate sales tax.)

_____ Shipping and handling (U.S.: \$2.50 ; Canada: \$4.00;
Foreign: \$6.00 first book, \$1.00 each additional.)

_____ **Grand total**

___ **Check or Money Order** ___ **MC** ___ **VISA**

Signature _____

(Required)

Acct. No. _____ Exp. Date _____

Name _____

Street Address _____

City _____ State _____ ZIP _____

Send this entire coupon to:

COMPUTE Books
c/o CCC
2500 McClellan Ave.
Pennsauken, NJ 08109

Please allow four to six weeks for delivery Offer good while supplies last.
All orders must be paid in U.S. funds drawn on a U.S. bank.

GET OVER 500 WINDOWS TIPS FROM COMPUTE'S 101 ESSENTIALS SERIES

101 Essential Word for Windows Tips (covers Word 2.0)
 101 Essential Windows Tips (covers Windows 3.0 and 3.1)
 101 Essential Access for Windows Tips (covers Access 1.0 & 1.1)
 101 Essential WordPerfect 5.2 for Windows Tips
 101 Essential Excel for Windows Tips (covers Excel 4.0)
 Total (Each book is \$9.95)
 Tax (Residents of NC, NJ, and NY add appropriate sales tax.)
 Shipping and handling (U.S: \$2.50; Canada: \$4.00;
Foreign: \$6.00 first book, \$1.00 each additional.)
 Grand total

Check or Money Order MC VISA

Signature _____

(Required)

Acct. No. _____ Exp. Date _____

Name _____

Street Address _____

City _____ State _____ ZIP _____

Send this entire coupon to:

COMPUTE Books
c/o CCC
2500 McClellan Ave.
Pennsauken, NJ 08109

Please allow four to six weeks for delivery. Offer good while supplies last.
All orders must be paid in U.S. funds drawn on a U.S. bank.

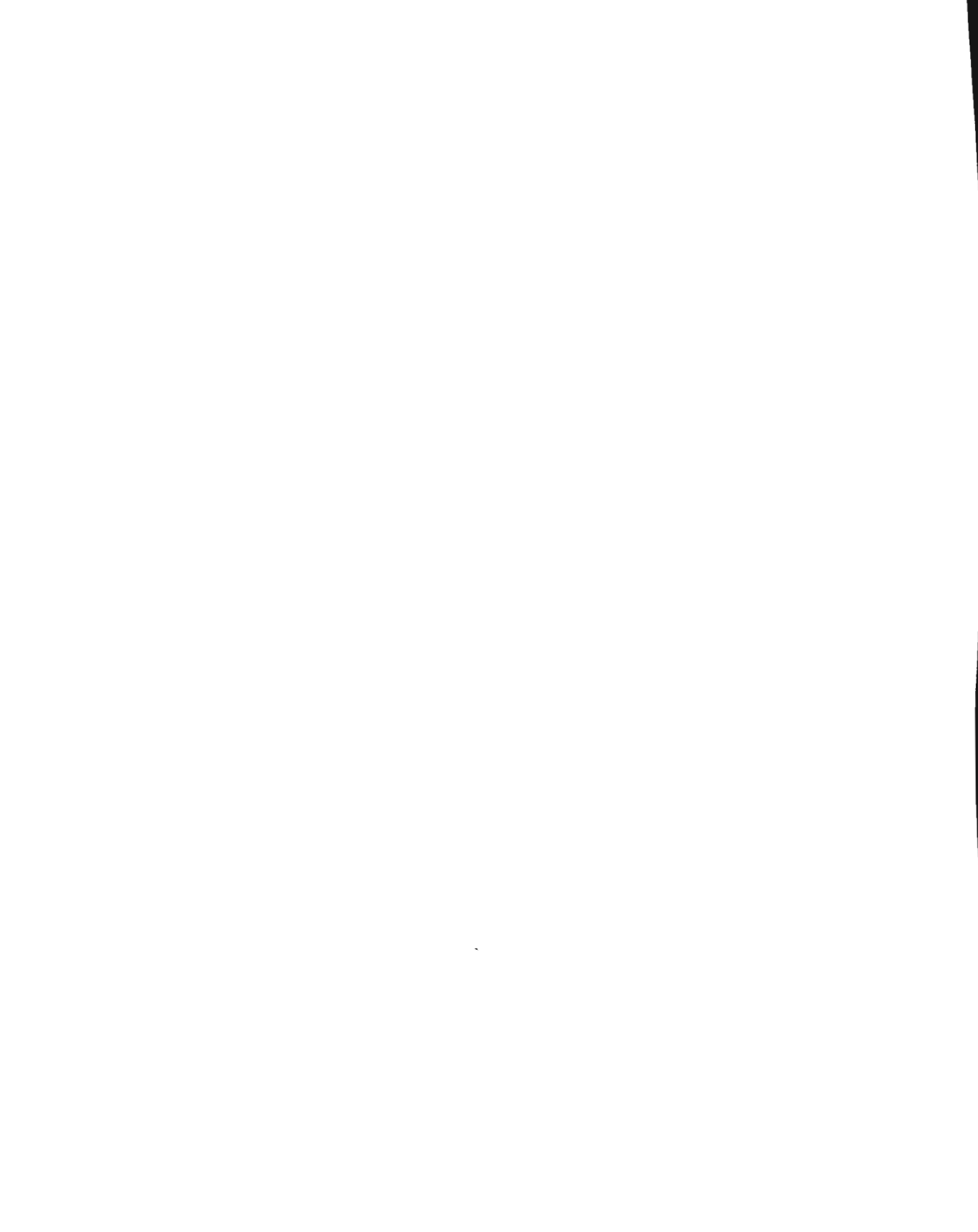

the ultimate guide to adventure games!

Help Roger Wilco save the galaxy in *Space Quest V*! Guide the noble Avatar past the Lizardmen as he attempts to rescue the beautiful Ariel in *Ultima Underworld*! Dodge Nazis as you uncover the secrets of a lost world in *Indiana Jones and the Fate of Atlantis*!

- Reveals thousands of secrets previously known only to the programmers (including *cheat modes*)
- Beautifully illustrated with more than 300 game snapshots, digitized images, and map illustrations
- An elaborate critique and scenario for each game
- Comments about special features and a system-availability list for every game
- Helpful strategies to enhance your gaming skills

A world of adventure awaits you in *COMPUTE'S Adventure Game Player's Handbook*, the ultimate tool for uncovering the secrets of 37 of the most popular computer adventure games available today, including hot new games like *The 7th Guest*, *Inca*, and *Freddy Pharkas: Frontier Pharmacist*. *COMPUTE'S Adventure Game Player's Handbook* gives you all the information you need to win, including specific hints, secret cheat modes, and detailed maps. With this book, you'll find your way out of frustrating dead-ends and start winning games!



Alone in the Dark
Amazon
Conquests of the Longbow
The Dagger of Amon Ra
Dark Seed
EcoQuest
Eric the Unready
Freddy Pharkas
Goblins 2
Heart of China
Inca
Indiana Jones
King's Quest V
King's Quest VI
Leather Goddesses
of Phobos 2
The Legend of Kyrandia
Leisure Suit Larry V
Les Manley in: Lost in L.A.
The Lost Files
of Sherlock Holmes
Lost Secret of the
Rainforest
Martian Memorandum
Mixed-Up Fairy Tales
Monkey Island 2
Police Quest 3
The Prophecy
Quest for Glory III
Rex Nebular
Ringworld
Rise of the Dragon
The 7th Quest
Space Quest IV
Space Quest V
Spellcasting 301
Star Trek
Ultima Underworld
Ultima Underworld 2
Willy Beamish