

ISSUE SE1 - 2014

Get printed copies
at themagpi.com

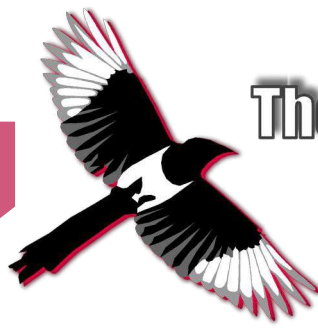

The MagPi™

A Magazine for Raspberry Pi Users

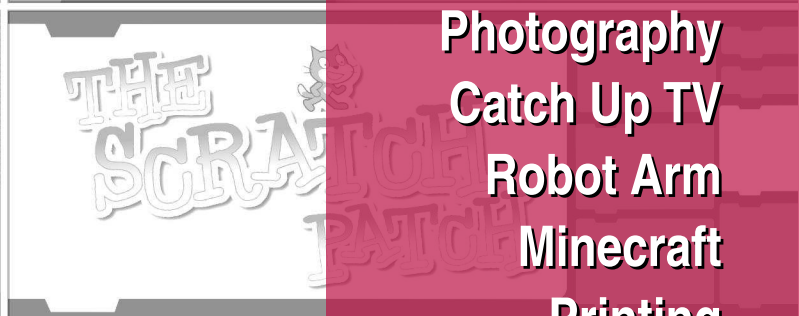
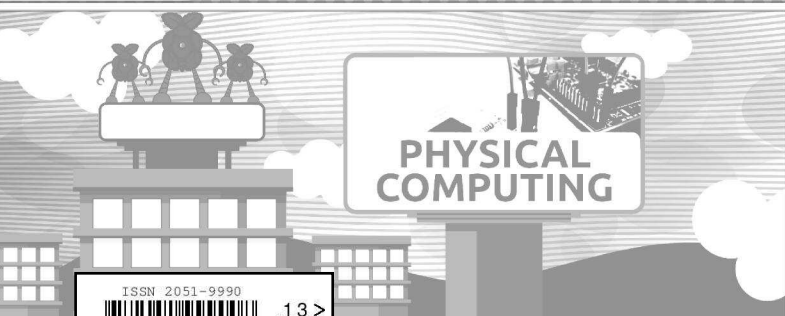
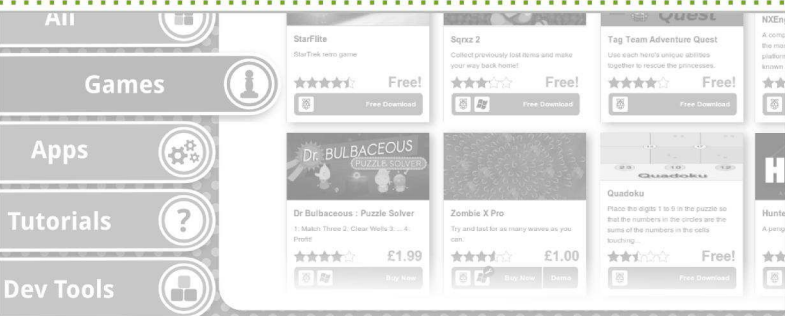
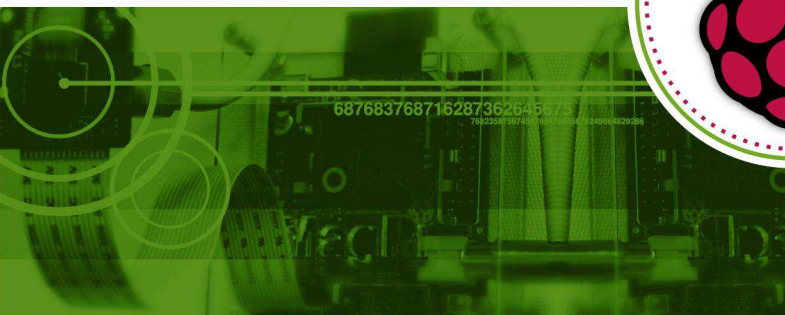
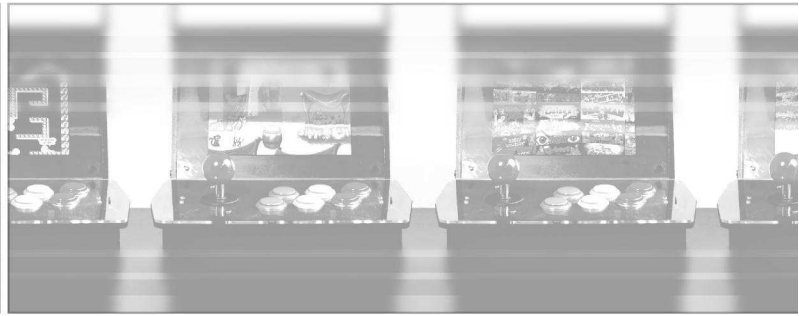
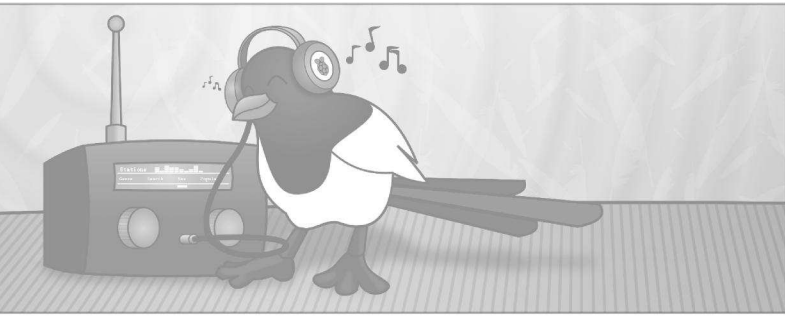

Internet Radio
Retro Gaming
Photography
Catch Up TV
Robot Arm
Minecraft
Printing
...and much more



Raspberry Pi is a trademark of The Raspberry Pi Foundation.
This magazine was created using a Raspberry Pi computer.



The MagPi™

<http://www.themagpi.com>



Welcome to this Special Edition issue of The MagPi - a whopping 132 pages of articles taken from the past 29 issues. This is not a "best of" issue... there are many, many other fantastic articles in every issue of The MagPi. Instead we consider this Special Edition a taster of what you can find in every issue of The MagPi, plus it is a great place to start if you have recently got a Raspberry Pi but are not sure what to do with it. Whether you are 9 or 92, there is going to be something here to interest you.

The Raspberry Pi is a very versatile computer that can be used to learn a variety of different programming languages, build simple or complicated electronics projects and even control autonomous vehicles. Getting to grips with the Raspberry Pi, in all of its possible applications, introduces many skills that are vital in industry and research. It is also a whole lot of fun for hobbyists!

This Special Edition contains some excellent Scratch and Python programming articles that are suitable for the complete beginner. They introduce concepts that can be expanded and implemented in other programming languages. There are also several hardware projects. We introduce you to the GPIO with simple buttons and LEDs, then explain how to control your garage door and a robot arm.

The Raspberry Pi camera is a popular addition to the Raspberry Pi and we have several articles that show you how to get the best out of this device. Media is another popular topic and we explain how the Raspberry Pi can be used to listen to internet radio, watch TV programmes plus how to 'get your groove on' with Sonic Pi.

Since the first issue of The MagPi appeared in May 2012, we have produced over 1,200 pages of content, created by 100+ different authors. There have also been over 50 volunteers who helped layout the magazine, tested the hardware and code plus proof read the text. Hundreds of hours of work goes into creating each issue of The MagPi, for your enjoyment and education... and it's free!

If you want to know when each issue of The MagPi is available, we invite you to join the 5,000+ other people who are following us on Facebook at <http://www.facebook.com/MagPiMagazine>.

We hope you enjoy this collection as much as we did putting it together. Thank you, from everyone at The MagPi.

The MagPi Team

Ash Stone - Chief Editor / Administration

Ian McAlpine - Issue Editor / Layout / Testing

W.H. Bell - Administration / Testing

Bryan Butler - Page Design / Graphics

Matt Judge - Website

Nick Hitch - Administration

Colin Deady - Testing / Proof Reading

Aaron Shaw - Administration

Dougie Lawson - Testing

Age-Jan (John) Stap - Testing

Tim Cox - Testing

Claire Price - Testing

Contents

- 4 BEGINNERS GUIDE**
Where can I get help? Answers to common questions
- 7 SCRATCH PROGRAMMING**
Racing game, Frogger, Simon, GPIO interfacing, fractals, encryption, projectile game, Mars lander
- 32 MINECRAFT**
Programming Minecraft, Minecraft and the GPIO, adding QR codes
- 44 AMY MATHER INTERVIEW**
The future of young hackers?
- 48 TV AND RADIO**
Use your Raspberry Pi to watch TV and listen to internet radio
- 58 GAMING**
Arcade emulation, using game controllers, Elite, Python game
- 76 PI STORE**
A look at the diverse range of applications in the Pi Store
- 80 PHYSICAL COMPUTING**
Introduction to the GPIO with buttons, switches and LEDs
- 88 HARDWARE PROJECTS**
Garage door interface, "Magic Wand", controlling a robot arm
- 100 PRINTING**
Connect your Raspberry Pi to a printer
- 104 RASPBERRY PI CAMERA**
How to use the Raspberry Pi camera plus time-lapse video
- 119 ALGOID**
Learn to program video games
- 124 SONIC PI**
Programming Christmas carols plus get your groove on with samples, synths and studio effects

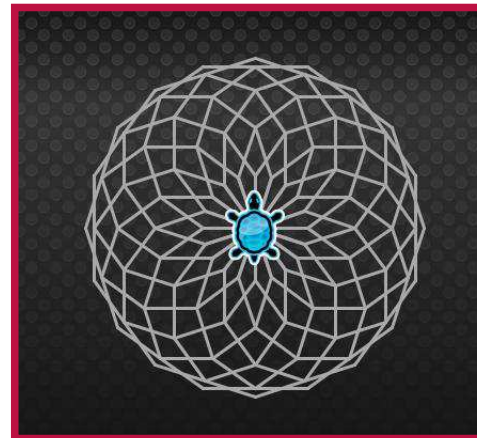
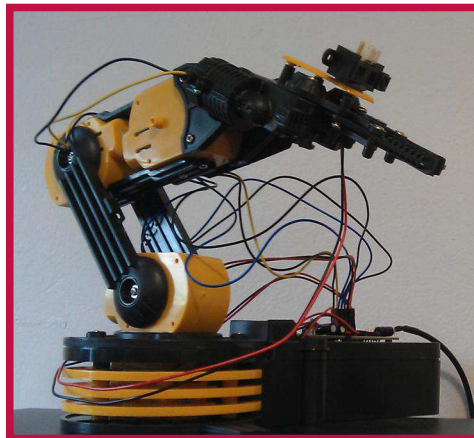

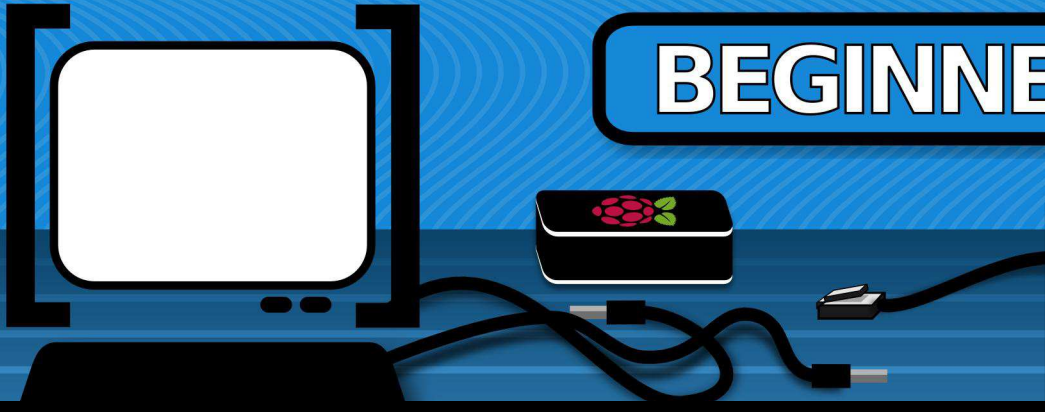

Adrian Harper
MagPi Writer

Where can I get help?

SKILL LEVEL : BEGINNER

There are numerous guides to getting started with a Raspberry Pi that cover the basics of setting up your new computer with the recommended Raspbian Wheezy operating system, running through `raspi-config` etc. However, most setup guides stop once the system boots into the windows style interface of LXDE.

I regularly encourage people to buy and use Raspberry Pis, especially if they have kids, but time and again I hear people asking "*Ok I'm at the desktop, what now?*", and "*How do I do such and such?*".

The official forums at raspberrypi.org are a great place to start looking for solutions to problems or questions that you might have, though they can be a bit daunting for a beginner. The search functions on the forum are excellent, so please take a few minutes to search the existing posts for answers to your questions before starting a new thread.

The web offers some exceptional free user guides that go into great detail to cover the installation of Raspbian Wheezy on an SD card from Windows, OSX and Linux. Engadget's Getting Started Guide is especially good - <http://engt.co/PZbUpT>. These guides offer help

with troubleshooting basic issues as well as providing ideas for that "*What now?*" moment when everything is running and you're staring at a large raspberry in the middle of the screen. The Raspberry Pi Guide on the Embedded Linux wiki is also recommended - <http://bit.ly/pJfgMr>.

Even with the user guides and forums, it is worth mentioning the solutions to a few of the most common questions asked by new Raspberry Pi owners:

I would like to connect x device to my Raspberry Pi. How can I be sure it is going to work?

Unless you like the challenge of writing drivers and figuring out why a piece of hardware connected to your computer does not function as it should, before buying any peripherals for your Raspberry Pi, check the list of verified peripherals on the Embedded Linux wiki - <http://bit.ly/Ae6JbF>.

Members of the Raspberry Pi community are extremely active in finding and documenting which devices work and which don't, so you don't have to!

How do I set my screen resolution when using a monitor connected by VGA / DVI?

With an HDMI connection the Raspberry Pi can detect and set the resolution correctly (in most cases) for the screen that is being used. For those of us that need to connect a monitor using an HDMI to DVI cable or an HDMI to VGA convertor box the resolution may need to be set manually.

While not being as intuitive as selecting a resolution from a preferences screen, a change can be easily made by editing a config file in the Terminal. To find the correct setting for your device, look up the resolution list on the Embedded Linux wiki - <http://bit.ly/1154mFm>.

It is normally easier to find the correct resolution in the second list that shows the screen size in pixels e.g. 1024 x 768.

```
These values are valid if
hdmi_group=2 (DMT)
hdmi_mode=13      800x600    120Hz
hdmi_mode=14      848x480    60Hz
hdmi_mode=15      1024x768   43Hz
hdmi_mode=16      1024x768   60Hz
hdmi_mode=17      1024x768   70Hz
hdmi_mode=18      1024x768   75Hz
```

Make a note of the `hdmi_mode=X` setting for the resolution you wish to apply.

Within terminal enter the following command:

```
sudo nano /boot/config.txt
```

This will open the configuration file in the Nano editor to allow you to make a change. Scroll down the file to the comment

```
# uncomment to force a specific
# HDMI mode (this will force VGA)
```

Remove the `#` to uncomment the two lines `hdmi_group` and `hdmi_mode` and then edit them to read:

```
hdmi_group=2
hdmi_mode=xx
```

where `xx` is the number of the resolution mode you wish to use. Following on from my example above, for a 1024 x 768 resolution, I would use the line `"hdmi_mode=16"`.

In this example, the relevant section of the `config.txt` file would look like:

```
hdmi_force_hotplug=1

# uncomment to force a specific
# HDMI mode (this will force VGA)
hdmi_group=2
hdmi_mode=16

# uncomment to force a HDMI mode
# rather than DVI. This can make
# audio work in
# DMT (computer monitor) modes
#hdmi_drive=2
```

After saving the file in Nano (CTRL + X, Y to confirm and Enter to overwrite) and rebooting ("sudo reboot") your Raspberry Pi should restart with the new resolution.

Note: If you select a resolution from the first list on the website, e.g. 720p 60Hz, you must set `hdmi_group` to 1.

Where there are multiple resolution settings with different refresh rates, e.g. 60Hz, 75Hz etc., you might need to experiment to find the most suitable setting.

Most computer monitors support refresh rates of 60 and 70 Hz; modern televisions are generally higher.

Why does the screen lock icon in the bottom right corner of the LXDE screen not work?

The basic Raspbian Wheezy image does not come pre-loaded with a screensaver; hence the lock not functioning and you not being able to find any screen saver preferences in the application menu.

Fixing the issue is easy enough; you just need to install the LXDE screen saver from the terminal by giving the command:

```
sudo apt-get install xscreensaver
```

Once installed, find and launch the screen saver preferences from your application menu. You should be immediately prompted that the screen saver daemon is not running. Click ok to launch it now.

Within the preferences dialog you can choose which screen saver the system will use, the idle time before it starts and if/when the system requires a password to unlock. As soon as the screen saver daemon is running the screen lock icon will function correctly.

What do I have to do to get my non UK keyboard to work correctly in LXDE?

Raspi-config does a good job of easily setting the keyboard layout correctly in the console, but those with non UK keyboard layouts often complain about their layout setting not working in LXDE.

The solution to this issue is quite simple as long you know the two letter country code and layout variant (if applicable). If you do not know this information you can find it easily from your system (assuming you have selected the correct keyboard settings in Raspi-config) by using the command:

```
cat /etc/default/keyboard
```

and checking the entries `XKBLAYOUT` and `XKBVARIANT`.

```
# KEYBOARD CONFIGURATION FILE

XKBMODEL="logicda"
XKBLAYOUT="ch"
XKBVARIANT="de_nodeadkeys"
XKBOPTIONS=""
```

With this information to hand, you can edit the LXDE autostart configuration file to add the line `@setxkbmap XX YY` where `XX` is the two letter country code and `YY` the keyboard variant. In my case I would edit the file by using the command:

```
sudo nano
/etc/xdg/lxsession/LXDE/autostart
```

Then in the Nano editor, append the following line to the end of the file:

```
@setxkbmap ch de_nodeadkeys
```

After saving the file in Nano and rebooting the keyboard layout should be correct within LXDE.

I hope that I have given you some pointers to get started with your Raspberry Pi and the encouragement to dig into the available community resources to resolve any small issues that you have.

For those looking for additional help I can highly recommend the following three books that are available in both print and digital formats:

- Raspberry Pi User Guide by Eben Upton and Gareth Halfacree - <http://goo.gl/44UTXR>
- Make:Projects - Getting Started with Raspberry Pi by Matt Richardson and Shawn Wallace - <http://goo.gl/mMU5ZP>
- Programming the Raspberry Pi: Getting Started with Python by Simon Monk - <http://amzn.to/WyPM97>

THE SCRATCH PATCH

RACING SCRATCH

Dodging arcade game



W. H. Bell

MagPi Writer

Crash, bang, wallop! Create a simple racing car game

SKILL LEVEL : BEGINNER

One way to start programming is to write simple video games. Scratch has several handy functions which speed up the construction of basic games. This article demonstrates how to produce a racing car dodging game. The game can be easily extended and the principles can be used when writing games using Python or C.

The idea of the game is to drive the car around several objects which scroll down the screen. The game ends if the car goes on the grass or touches one of the objects.



The first step to produce this game is to create or choose the sprites. The racing car was drawn with the Scratch sprite editor. To make the sprite symmetric, half was copied and then mirrored. Once the working car has been produced, go to the Costumes tab of the sprite and click on copy. Then click on Edit for the second sprite.

The second costume will be used for the broken car. The Scratch editor was used to make the car look broken. Before writing the script for the car, some objects are needed. In this case, the ball and the Lego piece were chosen from the Scratch sprite library. The library of sprites can be viewed by clicking on the folder icon, just below the stage.

```

when clicked
  forever
    if key left arrow pressed?
      change x by -5
    if key right arrow pressed?
      change x by 5
    if key up arrow pressed?
      change y by 5
    if key down arrow pressed?
      change y by -5
  
```

Racing car script

The racing car is controlled by a script which has three pieces. These three pieces run in parallel, which allows the program to check the conditions in each piece at the same time. The first block checks the keyboard. If the cursor keys are pressed, the car moves left, right, up or down the screen. The centre of the stage corresponds to $x=0$, $y=0$.

The second piece of the script checks to see if the car has touched the grey colour at the side of the road. This colour has to be the same as the colour used on the stage for the program to work. When the racing car touches the edge it says "Sois prudente!" (be careful!) for one second.

```

when clicked
  forever
    if touching color [grey]
      say Sois prudente! for 1 secs
  
```

```

when clicked
  go to x: 0 y: -100
  switch to costume costume1
  forever
    if touching color [green]
      switch to costume costume2
      stop all
    if touching Lego
      switch to costume costume2
      stop all
    if touching ballon
      switch to costume costume2
      stop all
  
```

The last part of the script checks to see if one of the game over conditions has been reached. There are three conditions which cause the game to finish; (1) the car touches the green grass colour, (2) the car touches a Lego brick sprite, or (3) the car touches a ballon (ball) sprite. In each case the racing car sprite is changed to costume2, which is the broken car. 'Stop all' then stops the game. This script block also resets the car position to the bottom of the screen when the game starts. $x=0$ is the middle of the screen in the horizontal direction and $y=-100$ is the bottom of the screen in the vertical direction.



Lego brick and ball

The lego brick and ball are controlled by the same program. To start writing the script for the Lego brick, click on the Lego brick sprite icon under the stage window. Then create the script given on the left of this page. When the script has been written, select all of it and click on copy. Then click on the ball and paste the script. For the ball, change the wait statement from 2.2 seconds to 3 seconds. As long as the two wait statements are not multiples of each other, the two objects will not arrive at the same time.

The script for the Lego brick and ball starts by hiding the sprite. The sprite is then put at the top of the screen, pointing down. The script then enters a loop. Each time the loop runs, the script waits and then shows the sprite. It is then moved to the top of the screen. The starting position is chosen at random, along the x-axis (horizontal plane). The sprite is then moved down the

screen by 5 units at a time, until it touches the bottom of the stage. When the sprite touches the bottom of the stage it is hidden and the outer loop moves it back to the top.

The stage

To complete the program, draw the stage image. Similar to the racing car, half of the stage was drawn, copied and mirrored. The green and grey colours used in the racing car script were used for the edge of the road and the grass.

Possible extensions

There are several ways this program could be made better. The lines in the middle of the road could be changed for another image to create the illusion of movement. Sounds could be added for when the car moves or crashes. Some burning rubber marks could be added when the car slows down. Instead of a Lego brick and ball, try creating some other cars or cars that drive from the bottom of the screen to the top.

This game could be used as the basis for other games. For example, vertical scrolling space invaders is quite similar. Try swapping the racing car stage picture for a star field. Then add in some weird and wacky alien vehicles, which come racing down or drop things on the heroic space ship.

THE SCRATCH PATCH

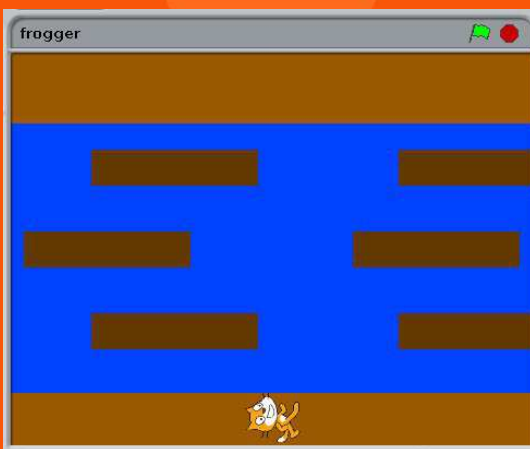

In this article we will make a very simple game in Scratch.

Even if you haven't made many games in Scratch before, you'll soon be Scratching with the best of them!

You can download this project from:
<http://scratch.mit.edu/projects/racypy/2668257>

The first thing to do is delete the cat sprite because we won't be using that. Right-click on it and choose "delete".

Next, we need to create a background. To do this, click on the white square in the "stage" area on the bottom right of the screen.

Then click on "backgrounds" in the centre panel and use the built-in paint application to make something like this.

Next you will need some sprites; one that looks something like a frog and six identical "logs". Click on the star and paint-brush in the "New Sprite" area, to create your sprites.

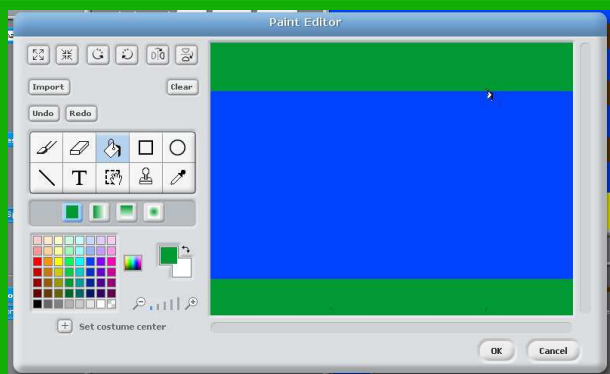

My attempt at drawing one was not very impressive!

```

when green flag clicked
  point in direction 0
  go to x: 0 y: -155
  forever
    if not touching color #000000?
      if not touching color #000000?
        stop all sounds
        play sound water$PLASH
        say Help! for 0.5 secs
        go to x: 0 y: -155
      if y position > 122
        play sound fanfare-1
        say Wow, I made it! for 2 secs
        stop all
  
```

```

when space key pressed
  if y position < 122
    play sound boing_x
    move 75 steps
  
```

```

when left arrow key pressed
  change x by -10
  
```

```

when right arrow key pressed
  change x by 10
  
```

```

when down arrow key pressed
  if not touching color #000000?
    move -75 steps
  
```

You'll need something like this script for your frog. The numbers referring to the positions of things may be different depending on how you drew the background. I've used some sounds I found online, but you could use the ones that come with Scratch - you'll need to import them first. Click on "Sounds" in the centre window.

Now you'll need six logs, each with a script. In the pictures, you can see the first pair of scripts. You'll need to experiment with changing the y coordinates for the other logs until you get them just right. Remember the frog moves by 75 steps each leap!

I hope you find this example helpful and go on to make some fun games yourself. As a challenge why not try to get the frog to ride along the logs?

Log script below. You need one for each log. In each script change the starting x and y coordinates and make the same change to the y coordinate in the second loop.

You want 3 rows of 2 logs. Rows 1 and 3 should move in the same direction. Can you get row 2 to move in the opposite direction?

```

when green flag clicked
  go to x: 0 y: -75
  repeat until x position > 280
    change x by 2
  forever
    go to x: -300 y: -75
    repeat until x position > 280
      change x by 2
  
```

THE SCRATCH PATCH

Make a "Simon" Memory Game!

This time we are going to use Scratch to make a memory game based on the classic toy: "Simon". If you've never heard of it, ask your parents (or grandparents!).

It's a simple game. Simon plays four notes and you have to repeat them in order. If you get it right, you get another sequence with more notes to remember - and it goes faster each time!



The original "Simon".

First, make four quarter-circle sprites. I did it by making a circle first and then selecting the bit I needed, discarding the rest. You'll need each one to have two "costumes": one a dark colour and one lighter (to look like a light is on!)

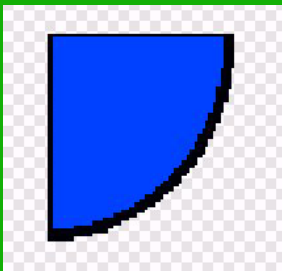

It's easy to make a second costume. After you have made your sprite, you'll see a tab called "costumes" in the center panel. Click on it and make a new costume.

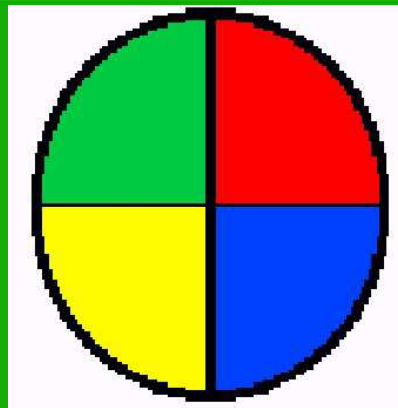

That's the hard bit done! Now we can write some scripts.

If you get stuck you can download the project from:

<http://scratch.mit.edu/projects/racypy/2695321>

The Scripts

These scripts control a sprite that is just a button with "New Game?" written on it.



```

when I receive play
  switch to costume costume1
  set Lives to 3
  set Score to 0
  set length to 4
  set time to .75
  set human_time to .5
  forever
    delete all of CPU_tones
    set human_player to False
    repeat length
      set tone to pick random 1 to 4
      add tone to CPU_tones
      broadcast tone and wait
    delete all of player_tones
    set human_player to True
    wait until length of player_tones = length of CPU_tones
    set human_player to False
    if CPU_tones = player_tones
      change Score by 1
      change length by 1
      set time to time * 0.9
    else
      say You made a mistake. for 1 secs
      change Lives by -1
      if Lives = 0
        broadcast new_game
        stop script
      else
        set temp to 1
        repeat length of CPU_tones
          broadcast item temp of CPU_tones and wait
          change temp by 1
    say Get Ready for 1 secs
  
```

This is the main script that controls the game! I gave it to the yellow segment sprite, but it doesn't really matter which sprite owns it.

```

when clicked
  broadcast new_game
  hide
  broadcast play

when I receive new_game
  show
  
```

Each segment sprite will need these scripts. You'll need to vary the numbers for the notes. I used: 60, 62, 65 and 67.

```

when Sprite1 clicked
  if human_player = true
    switch to costume costume2
    play note 60 for human_time beats
    add 1 to player_tones
    switch to costume costume1

when I receive 1
  switch to costume costume2
  play note 60 for time beats
  switch to costume costume1

when clicked
  switch to costume costume1
  
```

THE SCRATCH PATCH



Scratch Controlling GPIO

This article intends to make it as EASY AS PI to get up and running with GPIO in Scratch and allow your Raspberry Pi to control some lights and respond to switches and sensors.

Whilst the Raspberry Pi is a great tool for the creation of software, using languages such as Scratch, Python, C etc., the best way to make it really come alive and to add even more enjoyment to this cheap, credit card sized computer is to start playing around with hardware hacking and physical computing. This involves using the Raspberry Pi to control things like LEDs and respond to switches and sensors. More often than not it also includes knowledge and learning of both hardware and software in a very interesting practical environment - not just coding for the sake of coding but, for example, creating robots and programming them to do cool things!

This article is based on a post on the Cymplecy blog by Simon Walters, a primary school ICT teaching assistant and general Scratch guru! The latest details are at <http://simplesti.net/scratchgpio/>.

Minimum Requirements - a Raspberry Pi with Raspbian installed and a working internet connection, a breadboard, some Light Emitting Diodes (LEDs), some resistors and some wire connectors. Total cost £5-£10 (not including the Pi).

How to get a Raspberry Pi to control the GPIO Pins from Scratch

Your Raspberry Pi needs to be connected to the internet to install the software but internet is not needed to run Scratch GPIO. Copy the text below (starting at sudo and ending at gpio.sh) and paste that into an LX Terminal window and run it to download the installer:

```
sudo wget http://goo.gl/xzJlz7 -O isgh6.sh
```

And then type, and run: `sudo bash isgh6.sh`

This will install all the necessary extra software and some simple examples. (If you do not have internet on your Pi then put your SD card into a card reader and try using your browser to right-click and save the script direct to your SD card and then put it back into your Pi and run the second instruction)

Connecting Components Up

Extreme care should be taken when connecting hardware to the GPIO pins as it can damage your Pi - only do this if you're confident of your ability to follow these instructions correctly. At a minimum you should get a breadboard and use some female-male 0.1 leads (available from RS/CPC or your local Maplin). Check out some GPIO pin guides to make sure you know what pins do what.

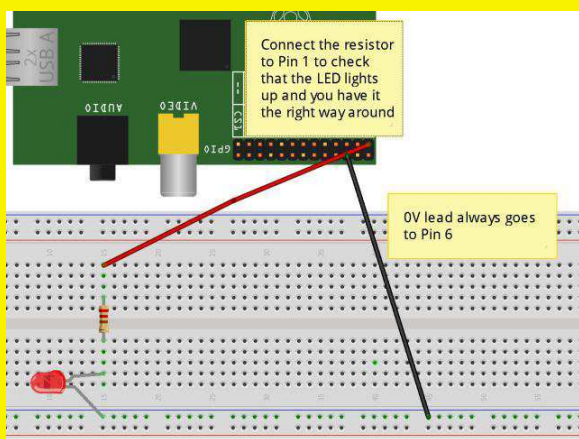

Figure 1 - LED Test

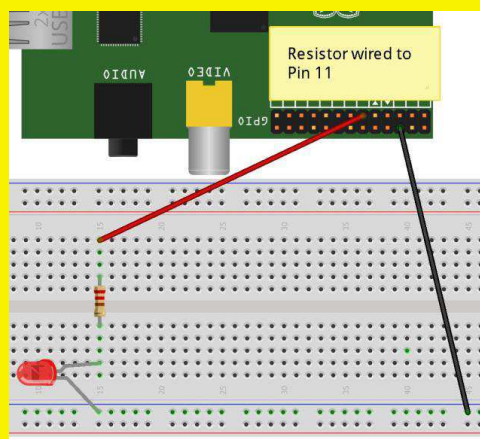

Figure 2 - GPIO Test

As in Figure 1 above, wire up Pin 1 (3.3V) to (at least) a 330ohm resistor - connect that resistor to the long lead (this is the positive lead) of an LED and then connect the other end of the LED to Pin 6 (Ground). This should cause the LED to light up. If it doesn't work try reversing your LED, as you probably have the polarities reversed. Once working, you can now move the red (or whatever colour you have used) lead from Pin 1 to Pin 11, as in Figure 2 above.

You should now run the special Scratch icon (Scratch GPIO) on your desktop. This is actually a completely normal version of Scratch, it just runs a little Python background program to allow Scratch to talk to the GPIO. If you have any Python programs accessing the GPIO running already this could cause your Pi to crash when opening Scratch GPIO. To avoid this, open an LX Terminal window and run: `sudo killall python`

To test out the GPIO control in Scratch, click File>Open and select blink11 from /home/pi/Scratch. Once the program has loaded, click on the Green Flag and your LED should now blink on for 1 second and off for 2 seconds - see troubleshooting on the Cymplecy blog if this doesn't happen.

Article by Simon Walters and Aaron Shaw

THE SCRATCH PATCH

The Julia Set

Over the next four pages we are going to use Scratch to draw some fractal patterns.

Gaston Julia, the French mathematician, did the early work on fractals which is why the patterns we will be creating are known as "Julia Sets". He was badly injured in World War One, which is why he wore a patch over the centre of his face.

The program to draw these patterns is actually quite simple! Let's start by deleting the cat sprite and making a new sprite with two tiny costumes.



Gaston Julia
(1893 - 1978)

Click on the paint new sprite button and then zoom in as far as possible. Erase what's there already and draw the smallest possible square (with the rectangle tool) and fill it in with red.

Call this costume "colour" and then make another one the same, except black, and call that "black".

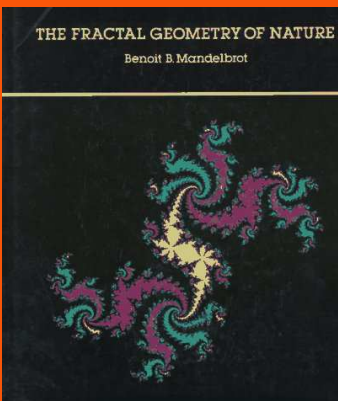
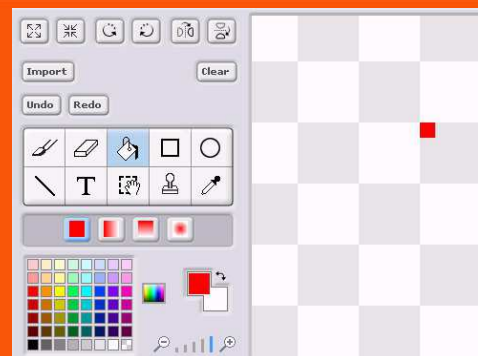

Mandelbrot continues Julia's work on fractals

In the 1970s the Polish mathematician Benoit B. Mandelbrot began to use computers to create images based on fractal mathematics. His book, "The Fractal Geometry of Nature", was very popular and introduced fractals to a much wider audience.

The Main Drawing Script

```

when I receive make_fractal
  set x to -200
  repeat until x = -180
    set y to -180
    repeat until y = 180
      set Z_Re to x * X_zoom
      set Z_Im to y * Y_zoom
      set ZI2 to Z_Im * Z_Im
      set ZR2 to Z_Re * Z_Re
      set Iterations to 0
      repeat until ZI2 + ZR2 > 4 or Iterations > Max_it
        set ZI to Z_Im * Z_Re
        set Z_Re to ZR2 - ZI2 + C_Real
        set Z_Im to 2 * ZI + C_Im
        set ZI2 to Z_Im * Z_Im
        set ZR2 to Z_Re * Z_Re
        change Iterations by 1
      go to x: x y: y
      if Iterations > Max_it
        switch to costume black
      else
        switch to costume colour
        set color effect to Iterations * Col_offset
      stamp
      change y by 1
    change x by 1
  stop script
  
```

This is the main script that draws the fractal image. It's crucial to create the variables correctly.

These variables MUST be **"For this sprite only"**: iterations, ZI, ZI2, ZR, ZR2, Z_Im, Z_Re, x, y.

These must be **"For all sprites"**:

C_Im, C_Real, Col_offset, Max_it, X_zoom, Y_zoom.

In the first few lines of the script, we set up which area of the screen this sprite will draw on.

This one does a strip 20 pixels wide: from $x = -200$ to $x = -180$.

When you have made this script you need to "duplicate" it 20 times.

Then change the values for x so that each sprite does another 20 pixels.

The last sprite should be in charge of $x = 180$ to $x = 200$.

This allows the program to draw to several parts of the screen at the same time which will speed things up a lot. I've gone with 20 "strips", you could try experimenting with other arrangements.

Here's an example of the type of images you will be able to create.

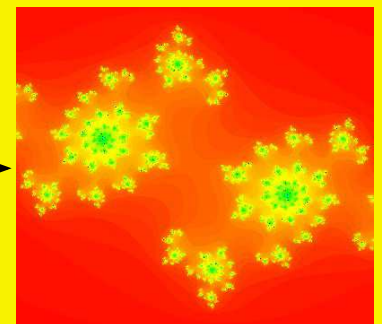

$$c = -0.7467 + 0.3515i$$

Scratch On!



***i* - the Imaginary Number**

The imaginary number, *i*, is the square root of -1.

The difficulty with *i* is that it is impossible to find a "normal" number that, when multiplied by itself, becomes -1.

Descartes did not like *i* and he gave it the name "imaginary number" as a kind of insult. However, after the work of Euler and Gauss, *i* quickly became an accepted part of mathematics.

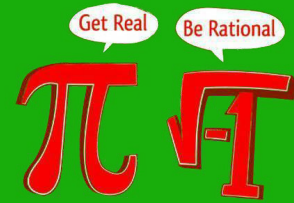

Complex Numbers

When we work with *i* we often use it as part of a "complex number". A complex number has a real part and an imaginary part.

$$C = a + bi$$

In this equation C is a complex number and it is made by adding the real part, a, to the imaginary part, b, multiplied by *i*.

The mathematics of the Julia set requires us to use complex numbers. When we make our fractal images you should picture the x axis of the screen as representing the real part of the complex number (a) and the y axis as showing us the value of the imaginary part (b).

Generating a Julia Set

As you will see on the next page, we give the program the values for the real and imaginary parts of C. Then the sprites visit every "pixel" in the region of the screen we are drawing on, treating it as a graph of the complex plane (this is what we call the visualisation of complex numbers that I explained above).

The current values for x and y are taken as the initial real and imaginary parts of Z (Z_Real and Z_Im). Then we iterate over a function:

$$z_1 = z^2 + c$$

If the value of the sum of the squares of the real and imaginary parts of z is more than 4, we consider that this location has "escaped" (if we carried on iterating, the number would get bigger and bigger) and we use the number of iterations completed so far to set the colour of the pixel.

If the values stay lower than 4 within the maximum iterations we have chosen the location is considered to be part of the Julia set and the pixel is coloured black.

The Wikipedia article on the Julia set is useful, if this (rather skimpy) explanation has not made the maths clear enough.

The Green Flag Script



This script is run when the green flag is clicked. You can give it to any of the sprites you've made (I'd suggest giving it to the first).

The most important thing is to enter the values of the real and imaginary part of C.

The colour image lower down on this page is known as "Douady's Rabbit" and has the following values for C:

Real: -0.123
Imaginary: 0.746

Next, you can specify the maximum number of iterations. I'd suggest you try about 20 at first. If you choose more you'll get a smoother range of shades in the picture but it will take longer to draw.

Setting the "zoom" allows you to focus in on a smaller area. A zoom of 1 is "normal size". You could see what happens when you enter 2 or 3 instead.

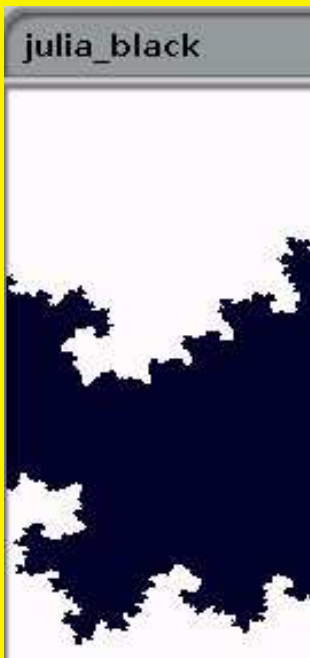

A monochrome image from an earlier version of the program.

Complex Numbers to try

If you search on-line for Julia set fractals you will find plenty of values for C to use in this program. Here are a few that I have used while testing this program:

Real: -0.4 Real: -0.8
Imaginary: 0.6 Imaginary: 0.156

Real: -0.1
Imaginary: 0.651

Real: -0.7467
Imaginary: 0.3515

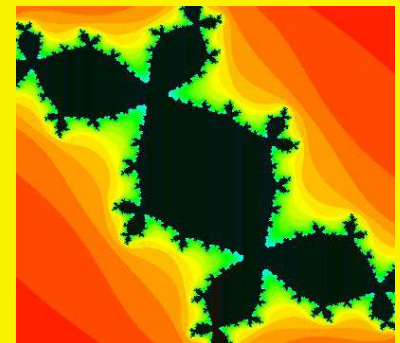

Douady's Rabbit

Download

If you get stuck, you can get the code here:

<http://tinyurl.com/gastonjulia/>

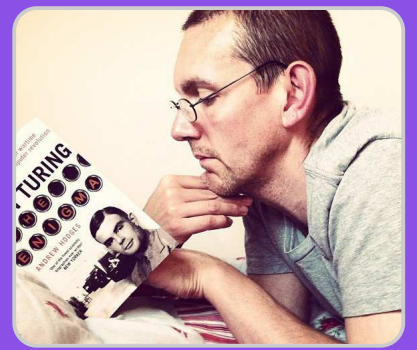

antiloquax
MagPi Writer

Pretty poor privacy

SKILL LEVEL : BEGINNER

This program shows you how to implement a "simple substitution" cipher with a reciprocal key. In a reciprocal key pairs of characters are mapped to each other. This makes life easier as we can use the same key to encipher and decipher messages. The resulting cipher texts are not too difficult to crack, but it's a start!

The first thing to do is make some sprites that will be the buttons we click to make things happen in our program (see the examples on the right).

To create a new sprite click the "paint new sprite" button just below the stage. You can delete the cat!

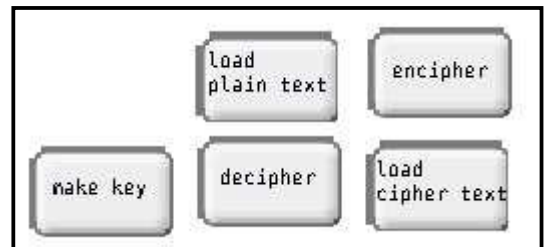

```

when Sprite4 clicked
delete all of plainAlpha
delete all of cipherAlpha
set alphabet to ABCDEFGHIJKLMNOPQRSTUVWXYZ~
set length to length of alphabet
set count to 1
repeat length
  add letter count of alphabet to plainAlpha
  change count by 1
repeat length
  set index to pick random 1 to length of plainAlpha
  add item index of plainAlpha to cipherAlpha
  delete index of plainAlpha
stop script
  
```

Here's the script that the "make key" button activates (the remaining scripts are on the following pages). To load a key you have already made, make the "cipherAlpha" list visible on the stage, then right-click it and "import" the key from the file in which it has been saved.

Alternatively, click the "make key" button. It's vital that your contact has a copy of your key so that he/she will be able to decipher your message. Right click "cipherAlpha" and choose "export" to save it to a text file for sharing.

Sprite 5 loads plain text from the "getText" list into a variable called "inputText". It puts in a "|" character to stand for line endings.

Sprite 6 loads cipher text you've imported into "getText". It ignores any spaces (these are put in to separate the cipher text into 5-character "words").

```

when Sprite5 clicked
  set length to length of getText
  set inputText to |
  set count to 1
  repeat until count > length
    set line to item count of getText
    set inputText to join join inputText line |
    change count by 1
  stop script
  
```

```

when Sprite6 clicked
  set length to length of getText
  set inputText to |
  set count to 1
  repeat until count > length
    set line to item count of getText
    set index to 1
    repeat until index > length of line
      set letter to letter index of line
      if not letter = |
        set inputText to join inputText letter
        change index by 1
      change count by 1
    stop script
  
```

```

when Sprite2 clicked
  broadcast cipher and wait
  set line to |
  set index to 1
  set count to 0
  delete all of textOut
  repeat length of outputText
    set letter to letter index of outputText
    if count = 24
      set line to join line letter
      add line to textOut
      set line to |
      set count to 0
    else
      set line to join line letter
      change count by 1
      if count mod 5 = 0
        set line to join line |
      change index by 1
    add line to textOut
  stop script
  
```

Sprite 2 is run when the "encipher" button is clicked and sprite 3 does the deciphering. Both call the cipher script before outputting the properly formatted text to the "textOut" list.

```

when Sprite3 clicked
  broadcast cipher and wait
  set line to |
  set index to 1
  delete all of textOut
  repeat length of outputText
    set letter to letter index of outputText
    if letter = |
      add line to textOut
      set line to |
    else
      if letter = -
        set line to join line |
      else
        set line to join line letter
      change index by 1
  
```

After calling the "cipher" block these scripts prepare the text for output. If we are preparing cipher text it is broken up into lines - each of which can have up to five, five-character cipher "words".

If we are preparing plain text any "|" symbols result in a newline being added, while a "~" is changed into a space.

The resulting text is then available in "textOut" and you can export to a text file if you wish.

This is the "cipher" script. It just goes through each character that is in "inputText". If the letter is a space, it changes it to a "~" before enciphering it. (If we are deciphering the dummy spaces will already have been removed).

It then looks through the key until it finds the letter. In the key letters are grouped in pairs. So if the index of the letter is an even number, the letter is replaced with the next letter in the list. Otherwise it is swapped for the letter before it.

```
when I receive Cipher
  set OutputText to 
  set Count to 1
  repeat length of inputText
    set letter to letter count of inputText
    if letter = 
      set letter to ~
    set Index to 1
    repeat until letter = item index of CipherAlpha
      change Index by 1
    if index mod 2 = 0
      set OutputText to join OutputText item index - 1 of CipherAlpha
    else
      set OutputText to join OutputText item index + 1 of CipherAlpha
    change Count by 1
  stop script
```



Scratch On!

In this example I've made the "inputText" variable visible so you can see that the message has been loaded.

```
getText
1 The process of preparing programs for a digital computer is especially attractive, not only because it can be economically and scientifically rewarding, but also because it can be an aesthetic experience much like composing poetry or music.
length: 1
```

The process of preparing programs for a digital computer

Here you can see the result of enciphering the opening sentence of Donald E. Knuth's classic book *The Art of Computer Programming*.

The cipher text is broken up into a series of lines, each line is one element in the list "textOut".

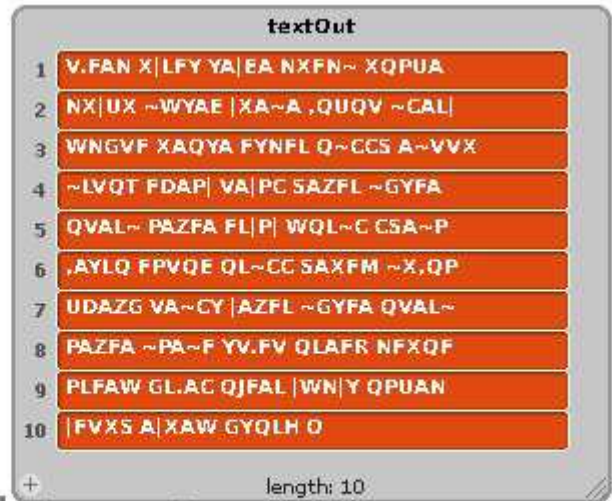

The process of preparing programs for a digital computer

V.FANX|LFYYA|EANXFN~XQPUANX|UX~WYAE|XA~A,QUQV~C

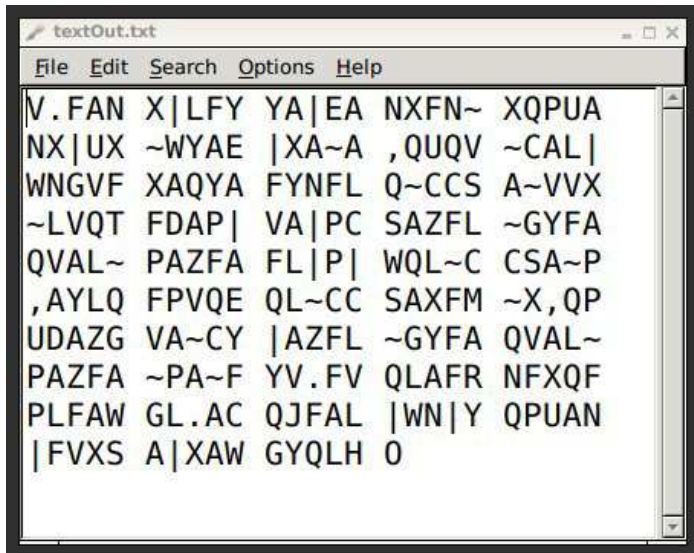

Here you can see what the message looks like after it has been exported and opened in leafpad.

If you get stuck, the program is available here:
<http://tinyurl.com/scratch-subs>

Here's the key I used in my example - in case you want to try deciphering the whole thing. Remember, it is a reciprocal key. Letters at odd numbered indices map to the next letter, while letters at even numbered indices map to the letter before. Scratch lists begin with index 1. So, 'K' is at index 3 and maps to 'J' at index 4. And 'J' maps back to 'K'.

O|KJTVFEIQ~ARX,DYSPN.HZBMWGUCL

If you are interested in learning more about cryptography, try this website:
www.simonsingh.net/The_Black_Chamber/



W. H. Bell

MagPi Writer

Physics of a cannon ball

SKILL LEVEL : BEGINNER

In this article we will create another simple arcade game. Similar to the racing car game, there is plenty of scope for expanding or modifying this game too.

The idea of the game is to try to hit the drum with the cannon ball. The cannon is controlled by the cursor keys and the spacebar, where the left and right keys change the angle of the cannon, the up and down control the initial speed of the ball and the spacebar fires the cannon.



There are three sprites in this program: the cannon, the cannon ball and the drum. The cannon was drawn using the rectangle tool. Different shades of grey were used to give the appearance of a round barrel. Then the picture was copied using the Copy button. The original picture was named ready and the copy was named fired. A muzzle flash was added to the fired costume.

The cannon ball is a marble taken from the Scratch library. The Drum is also from the Scratch library. Both of these sprites were resized to the correct size.

The gun carriage is part of the stage, where the cannon was positioned on top within the cannon script.

```

when clicked
  point in direction 59
  go to x: -174 y: -81
  switch to costume ready
  set fire to 0
  set start_velocity to 0
  set cannon_x to 0
  set cannon_y to 0
  set cannon_angle to 0
  set Score to 0
  forever
    if key left arrow pressed?
      turn 1 degrees
    if key right arrow pressed?
      turn 1 degrees
    if key up arrow pressed?
      set initial_speed to initial_speed + 0.2
    if key down arrow pressed? and initial_speed > 0
      set initial_speed to initial_speed - 0.2
    if key space pressed? and fire = 0
      switch to costume fired
      set fire to 1
      set cannon_x to x position of Cannon
      set cannon_y to y position of Cannon
      set cannon_angle to direction of Cannon
      wait 0.5 secs
      switch to costume ready
  
```

Cannon script

The cannon script starts by setting the position and costume of the cannon to the default. Then the script initialises all of the global variables with 0. The fire variable is used as a boolean, where 0 is false and 1 is true. The start_velocity is the initial velocity given to the cannon ball, when the ball is fired. The centre of the cannon is stored in the cannon_x and cannon_y variables. The cannon_angle is the angle in degrees, where zero implies that the cannon barrel is pointing straight up.

After the initialisation, the cannon reacts to either the cursor keys or the spacebar. Pressing the left and right cursor keys causes the cannon to rotate one degree to the left or one degree to the right. Pressing the up cursor key causes the initial speed given to the ball to be increased by 0.2, whereas pressing the down cursor key reduces the speed as long as it is greater than zero.

Pressing the spacebar will cause the cannon to fire if fire is also set to zero. The fire variable is used to prevent the cannon ball from being fired when the cannon ball is in flight. When the cannon is fired, the costume of the cannon is changed to show a flash. Then the fire variable is set to 1 and the global variables that describe the position of the cannon are set. After 0.5 seconds the flash is removed by resetting the costume.

Cannon ball scripts

The cannon ball has two scripts, one to hide the ball when the green flag is pressed and another to control the motion of the ball.

```
when space key pressed
hide
go to x: cannon_x y: cannon_y
point in direction cannon_angle
set velocity_x to initial_speed * cos of 90 - cannon_angle
set velocity_y to initial_speed * sin of 90 - cannon_angle
repeat until (touching color green ? or touching edge ? or touching Drum ?)
  change velocity_y by -0.05
  change x by velocity_x
  change y by velocity_y
  if (not touching color grey ? and touching color sky ?)
    show
set fire to 0
stop script
```

```
when green flag clicked
hide
stop script
```

When the spacebar is pressed the global variables `cannon_x`, `cannon_y` and `cannon_angle` are used to set the position of the ball and its initial velocity. Unlike other programming languages that use radians, Scratch uses degrees for the functions sine and cosine. The 90 degree offset is used to convert the angle of cannon, such that zero degrees corresponds to the cannon pointing horizontally to the right. The sine and cosine functions are then used to set the initial velocity components.

The cannon ball moves through the air until it touches either the colour green, the edge of the stage or the drum. While none of these conditions are met, the vertical velocity component is decremented by 0.05. This decrementation corresponds to the acceleration due to gravity. Next the current x and y components of the velocity are used to move the ball through the air. The speed with which the repeat-until loop executes corresponds to the time component.

The ball is hidden unless it has completely cleared the cannon barrel. This is achieved by checking if the ball is not touching grey and is touching the colour of the sky. Lastly, when the script finishes, the global variable `fire` is set to zero to allow the cannon to be fired again.

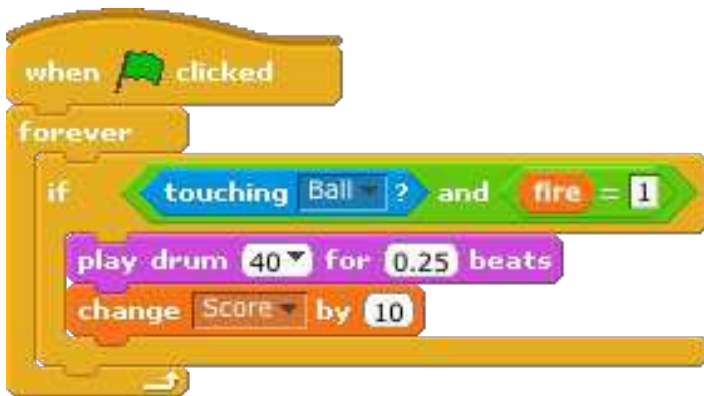

The drum script

There is one drum script, which is launched when the green flag is pressed. When the ball is launched, the global variable `fire` remains set to one until the ball touches down on the ground or the drum. Therefore, combining the `fire` variable requirement with touching the ball sprite implies that the program will enter the if statement once for one

cannon ball flight. Once the program has entered the if condition, the drum plays a simple sound and increments the global variable score by 10 points.

Rotating the cannon

In order for the cannon to be rotated around the centre of the cannon sprite, the `Set costume center` button should be clicked. Then put the crosshairs for both costumes at the middle of the sprite.

Projectile motion summary

The motion of a projectile can be split into vertical and horizontal components. Gravity acts in the vertical direction as a downward acceleration. In the program documented in this article, air resistance is neglected. Therefore, the horizontal velocity component is constant and the horizontal distance the projectile travels is found by multiplying the initial horizontal velocity by the time it is in the air. The time the projectile is in the air is determined as the difference between the start time and when the vertical position is equal to the ground. While the projectile is in flight, gravity continues to decrement the vertical velocity until the projectile hits the ground. If the initial vertical velocity component is small, it will not take long for gravity to bring the projectile down. Notice that within this simple program the vertical position is evaluated in two steps, rather than in one equation. There is one step to evaluate the change in velocity and another to update the horizontal position.

Possible extensions

The drum could be replaced with other objects that move around to make the game harder. There could be a time limit for the player to hit all of the targets with the cannon. The equation of motion used in this game does not include drag. Drag can be expressed as a constant force for a given velocity squared. The problem of estimating the drag could be made harder by introducing wind, which would cause the relative velocity of the ball with respect to the air to be higher.



W. H. Bell

MagPi Writer

Learning to land on Mars

SKILL LEVEL : BEGINNER

Adding natural physics processes to games can make them more real and thrilling to play. In the previous article, a simple projectile motion game was introduced. The game included gravity and initial velocity. These concepts can be used for other types of games too.

This month's game introduces the simulation of a spaceship landing on a remote planet, where the landing craft obeys the normal laws of physics. In this case, the Lander has rocket motors to change its direction.

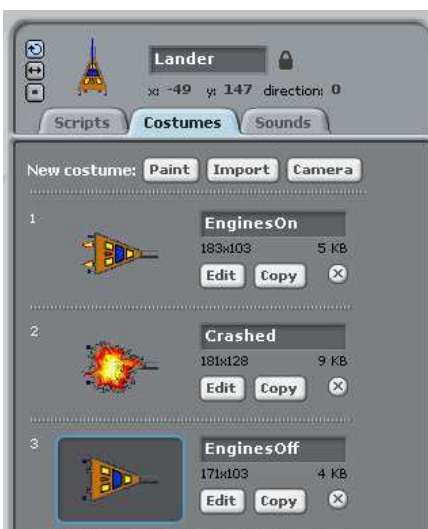

The idea of the game is to land the spacecraft on the landing pad. If the spacecraft lands on the surrounding ground, then it will explode. If the spacecraft does not touch down on the landing platform correctly, then it will explode too. The spacecraft must be travelling slowly when it touches down or it will be destroyed.

The Lander sprite has three costumes, to show the Lander with its engines on, when crashed, and when the engines are off. The costume with the engines off was copied and then modified to form the other costumes. The costumes were drawn on their sides, such that an angle of zero degrees corresponds to the spacecraft pointing straight upwards. (More details of the Scratch system of angles are given in Issue 17.)

The Stage

Two backgrounds were created for the Stage, where the size of the landing pad and the amount of surrounding red rock was chosen to be different. Once the background images had been drawn, the Lander sprite was resized to match landing pad by the right clicking the mouse on the Lander sprite. The colours used for the surrounding ground and the landing pad for the two backgrounds were chosen to be the same, to allow tests based on the colours of the sprite and the background. Then a simple script was written to select a random Stage background when the green flag is pressed.



Controlling the Lander

The Lander is controlled with the left and right arrow keys and the space bar. To prevent the controls from moving the lander when the game is not taking place, a local variable was created called flying. If the flying variable is set to one, then the controls will change the angle of the Lander sprite.

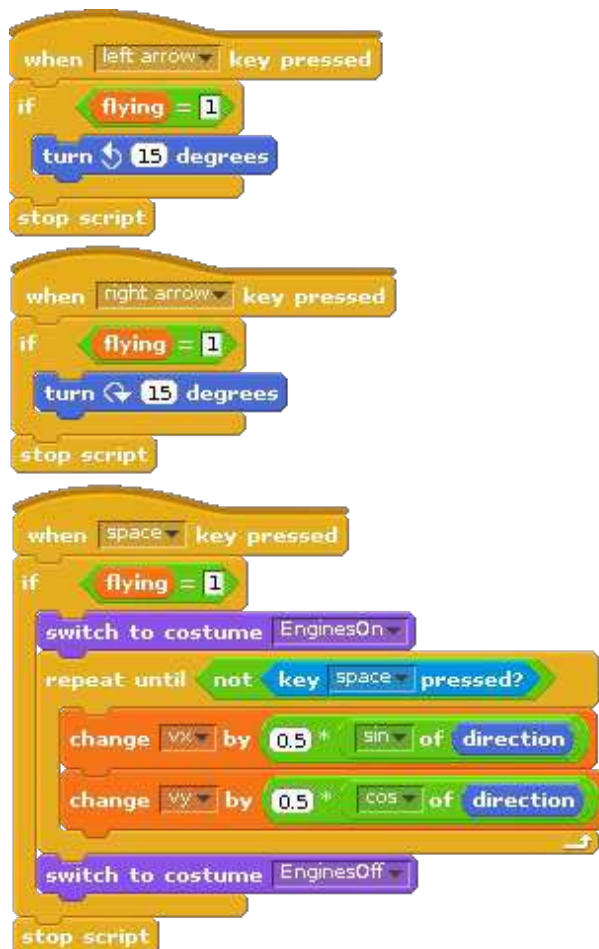

Tapping on the left arrow causes the Lander to turn 15 degrees to the left and tapping on the right arrow causes the lander to turn 15 degrees to the right.

The space bar is used to fire the thrusters, to slow down the Lander and manoeuvre it to the landing pad. When the space bar is pressed, the costume of the Lander changes to the version that shows the engines burning. The costume continues to show the engines burning, while the space bar is pressed. When the space bar is released, the costume changes back to show the engines as being off.

While the space bar is pressed the velocity of the Lander is increased, according to its current direction. The sine and cosine operators are used to calculate the increase of the x and y velocity components using the direction, where the velocity components are stored in local variables vx and vy respectively. The direction is zero, when the Lander points straight upwards, 180 when it points straight downwards, positive when it points to the right and negative when it points to the left.

The Lander in flight

```
when green flag clicked
  point in direction 0
  switch to costume EnginesOff
  go to x: pick random -120 to 120 y: 150
  set vx to 0
  set vy to 0
  set flying to 1
  repeat until flying = 0
    change vy by -0.02
    if color is touching red or color is touching red or color is touching red
      set flying to 0
      switch to costume Crashed
      say Crashed! for 2 secs
    else
      if color is touching grey
        set flying to 0
        if vy > -1 and direction = 0
          say Landed! for 2 secs
        else
          switch to costume Crashed
          say Crashed! for 2 secs
        else
          change x by vx
          change y by vy
  stop script
```

The Lander requires one more script block, to control the flight of the Lander and to check to see if it has crashed or landed. The script on the left performs this functionality.

When the green flag is pressed, the Lander is reset to point straight upwards, the engines are turned off and its position is chosen at random along the top of the screen. The local variables for the x and y velocity components and the flight status are also reset. The

main repeat until loop continues to run until the flying status has been reset to zero. The first step within the loop is to reduce the vertical velocity component by a small amount. This reduction of velocity is present to simulate the effect of gravity on the Lander. The next block within the loop checks to see if the Lander has touched the surrounding ground. If it has touched it, then the costume is changed to the

crashed version and the flying status is set to zero. If it has not touched the surrounding ground, then the program checks to see if the landing feet have touched the landing pad or not. If they have touched the landing pad, then the vertical velocity component and the direction of the Lander is checked. If the touch down is not successful, the Lander will be shown as crashed. If the landing is successful, then the Lander will say "Landed!". While the Lander is not in contact with the ground, the position of the Lander is updated using the velocity components. In this program, the speed of the loop regulates how fast time is passing in the simulation.

To make the game harder or easier, try changing the reduction of the vertical velocity in the loop (the effect of gravity) or try changing the effect of the thrusters. The lander could be given a limited amount of fuel, by counting the number of times the space bar is pressed.

The Raspberry Pi is helping millions of kids write their first

print 'hello world'

We'd like to thank you for
making cool projects,
spreading the word,

...and also for buying sweet, sweet swag

Your generous support helps us do more*

<http://swag.raspberrypi.org>

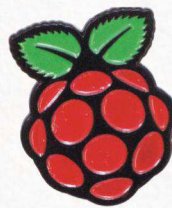

*Hello World is alright, but we've got to teach kids "20 GOTO 10" as well

MINECRAFT

PI EDITION

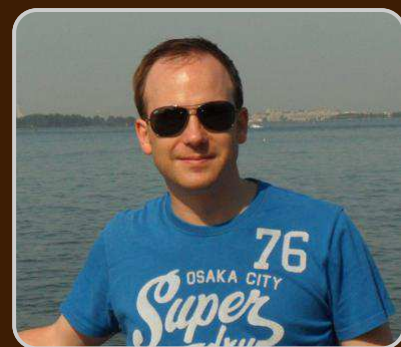

Martin O'Hanlon

Guest Writer

Minecraft: Pi Edition

SKILL LEVEL : INTERMEDIATE

The game

Minecraft is a game which has achieved monumental success - almost 30 million copies, across all its versions, have been sold; not bad for a game which doesn't really have a point! It is classified as an Indie Sandbox game. If it does have a point it is to make stuff (and people have really made stuff), from fully functioning computers to scale models of the Starship Enterprise to The MagPi bird!



Now Minecraft has come to the Raspberry Pi and the two best things about Minecraft: Pi Edition are it is free and comes with an API - two things you do not get with any other version of Minecraft (certainly not yet anyway).

Installing

If you have the latest version of Raspbian then Minecraft already comes preinstalled. If you do not have the latest Raspbian then let's get going by installing Minecraft and testing that it works.

Open an LXTerminal window and enter:

```
cd ~
wget https://s3.amazonaws.com/assets.minecra
ft.net/pi/minecraft-pi-0.1.1.tar.gz
tar -zxvf minecraft-pi-0.1.1.tar.gz
```

Make a note of /home/pi/mcpi/api/python as we will need that later. Test Minecraft with the following commands:

```
cd mcpi
./minecraft-pi
```

Playing Minecraft

The Raspberry Pi edition of Minecraft is a cut down version of the pocket edition and currently only offers one playing mode, Classic, which is all about exploring and building. Click 'create world' and start exploring and building.

You control your player with the mouse and keyboard:

Moving - the mouse changes where you look, while the arrow keys move you forward, backward, left and right.

Up and down - pressing space will make you jump while you are walking. Double tapping will start you flying. While you are flying, space will make you move up and shift will make you go down.

Inventory - you can cycle through your inventory using the mouse scroll wheel (or keys 1-8) and change the blocks in your immediate inventory (the strip along the bottom) by pressing E which brings up all the blocks you can use.

Destroy blocks - press (hold) the left mouse button.

Place blocks - press the right mouse button.

Back to menu - press escape.

The API

The API allows you to write programs which control, alter and interact with the Minecraft world - unlocking a whole load of Minecraft hacking. How about creating massive structures at the click of a button, a bridge which automatically appears under your feet allowing you to walk across massive chasms, a game of minesweeper or a huge clock?

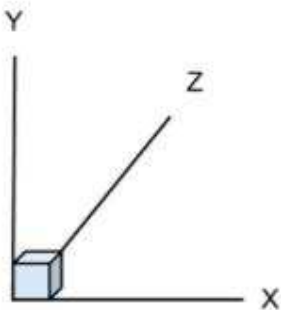

Minecraft is a world of cubes or blocks, all with a relative size of 1m x 1m x 1m. Every block has a position in the world of x,y,z. x and z are the horizontal positions and y is the vertical.

The API works by changing the 'server', which runs underneath the game, allowing you to interact with these blocks and the player, such as:

Get the player's position.

Change (or set) the player's position.

Get the type of **block**.

Change a **block**.

Change the **camera angle**.

Post messages to the player.

Libraries

You can interact with the server directly by sending a message to it, but the nice people at Mojang also provide libraries for Python and Java which simplify and standardise using the API. The libraries are installed along with the game in the `~/mcpi/api/java` and `~/mcpi/api/python` directories.

The following example is written in Python and uses Mojang's Python API library. The first task is to create a directory for your API program.

API example

1) Create directory

```
mkdir ~/minecraft-magpi
```

2) Open Idle (or your favourite editor) and create a program file called `minecraft-magpi.py` in the `~/minecraft-magpi` directory.

3) Next we import the `sys` package and add the API directory to the system path so that Python can find the Minecraft Python API packages. Note, please choose the correct path depending if you installed Minecraft or it came pre-installed:

```
#!/usr/bin/python
import sys
sys.path.insert(1, '/home/pi/mcpi/api/python')
sys.path.insert(1, '/opt/minecraft-pi/api/python')
```

We need to import 3 packages to connect to the Minecraft world, build blocks and introduce delays into our program:

```
import minecraft.minecraft as mine
import minecraft.block as block
import time
```

Next, we need to use the Minecraft class in the Python library to create a connection to the game's server. We will use this object to interact with the game and provide access to all the functions. When your program runs the following statement, Minecraft will have to be running and you will need to be in a game, otherwise you will get errors.

```
mc = mine.Minecraft.create()
```

Using our `minecraft` object, `mc`, we can then interact with the game and send the player a message. We will also put a delay in using the `time.sleep()` function otherwise the whole program will run too fast to see what is going on.

```
mc.postToChat("Hello Minecraft World")
time.sleep(5)
```



Using the program built so far, you can test to make sure everything is working. Load up Minecraft and create a world (or enter an existing one). Press ALT+TAB to switch to your editor. If you're using Idle select 'Run Module' from the Run menu. If all has been setup correctly you will see the "Hello Minecraft World" message in the game.

Interacting with the player is done through the `player` class of the `mc` object allowing us to find and change the position of the player. The next block of code finds the player's position using the `getPos()` command which returns an object of x,y,z coordinates. The `setPos()` command is then used to move the player 50 blocks up by adding 50 to the player's y coordinate. We then add a delay so there is enough time for your player to fall down to the ground!

```
playerPos = mc.player.getPos()
mc.player.setPos(playerPos.x, playerPos.y +
50, playerPos.z)
mc.postToChat("Don't look down")
time.sleep(5)
```

You can use the position of the player as a starting point for interacting with blocks. This way you can find out what block the player is standing on or place blocks around the player. There is however a challenge as the x,y,z coordinates returned by the `getPos()` function are decimals (aka floats) as the player can be in the middle of a block. To interact with blocks we need to use whole numbers (aka integers), so we need to use the function `getTilePos()` which returns the block (or tile) he's standing on.

The following code gets the player's tile position. It then calls the Minecraft API's `getBlock()` function to find out the type of block the player is standing on (by subtracting 1 from the y coordinate) before using `setBlock()` to create blocks of the same type the player is standing on around him. So if your player is standing on DIRT, he will end up with DIRT surrounding him, however if he is standing on STONE, STONE will appear.

```
playerTilePos = mc.player.getTilePos()
blockBelowPlayerType =
mc.getBlock(playerTilePos.x, playerTilePos.y -
1, playerTilePos.z)
mc.setBlock(playerTilePos.x + 1,
playerTilePos.y + 1, playerTilePos.z,
blockBelowPlayerType)
mc.setBlock(playerTilePos.x, playerTilePos.y
+ 1, playerTilePos.z + 1, blockBelowPlayerType)
mc.setBlock(playerTilePos.x - 1,
playerTilePos.y + 1, playerTilePos.z,
blockBelowPlayerType)
mc.setBlock(playerTilePos.x, playerTilePos.y
+ 1, playerTilePos.z - 1, blockBelowPlayerType)
mc.postToChat("Trapped you")
time.sleep(5)
```



We have now trapped our player within four blocks (providing he doesn't break out!). In order to set him free we need to remove a block. Removing blocks is done using `setBlock()`, but rather than making the block solid like WOOD or STONE we set it to AIR.

```
mc.setBlock(playerTilePos.x + 1,
playerTilePos.y + 1, playerTilePos.z,
block.AIR)
mc.postToChat("Be free")
time.sleep(5)
```

A full list of all the available blocks can be found in either the Minecraft API specification or in the `block.py` module in the Python API library `~/mcpi/api/python/mcpi/block.py`.

The API also allows you to set many blocks at a time, allowing you to create cuboids very quickly using the `setBlocks()` command. It works by specifying 2 sets of x,y,z coordinates between which it then fills the gap with a certain block you pass as the final parameter. The following code will create a diamond floor underneath our player 50 blocks (across) x 1 block (up) x 50 blocks (along), with our player in the middle (i.e. 25 behind and to the left, 25 in front and to the right).

```
mc.setBlocks(playerTilePos.x - 25,
playerTilePos.y - 1, playerTilePos.z - 25,
playerTilePos.x + 25, playerTilePos.y -1,
playerTilePos.z + 25, block.DIAMOND_BLOCK)
mc.postToChat("Now thats a big diamond
floor!")
```



To recap on the functions covered in this article:

postToChat(message) - communicate with the player(s) in the game.

getBlock(x, y, z) - get a block type for a specific position.

setBlock(x, y, z, blockType, blockData) - set (change) a block to a specific blockType.

setBlocks(x1, y1, z1, x2, y2, z2, blockType, blockData) - set lots of blocks all at the same time by providing 2 sets of co-ordinates (x, y, z) and fill the gap between with a blockType.

player.getPos() - get the precise position of a player.

player.setPos(x, y, z) - set (change) the players position.

player.getTilePos() - get the position of the block where the player currently is.

There are few other functions available in the API which should be explored. Using only the small number discussed in this article it is possible with some imagination and a small amount of programming knowledge to create some quite fantastic constructions, tools and utilities.

I love Minecraft. It is a tremendously creative game and with the Raspberry Pi edition's API it opens up new levels of creativity and will hopefully encourage more people to try their hand at programming.

Creating the Issue 11 cover from blocks to virtuality

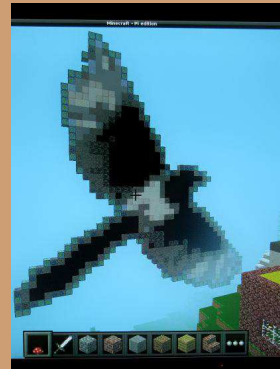

Ian McAlpine created the impressive Minecraft magpie on the cover of Issue 11. The MagPi asked Ian how he achieved this.

With the Minecraft API installed (see main article text) I decided I wanted to create a large copy of the magazine's logo that would be easily recognisable in the game world, using Python. This was my very first Python program. Coding the magpie rather than building manually gave me the freedom to place the magpie anywhere in the Minecraft world. The whole thing was very experimental, balancing effort in terms of pixelation while still retaining an obviously recognisable image.

Having identified that I was limited to eight shades of black/grey/white and four shades of blue in terms of Minecraft blocks, that partially determined the pixelation. Using Gimp on my Raspberry Pi, I pixelated The MagPi magpie image to 43x44 blocks. This seemed to be the right balance... but still meant manually mapping 1892 squares to Minecraft blocks! It could be made smaller but the pixelation would be more coarse and the magpie less recognisable.

In Python, the image is represented by a list of lists (i.e. a 2-dimensional array). Each cell in the array was given a character; 1-8 for black, white and shades of grey plus A-D for the shades of blue. 0 represented the "Air" block type. Five other variables were used; three for the x, y, z coordinates, one for the angle in the vertical plane (0, 90, 180 or 270 degrees) and a variable to indicate if the magpie should be plotted or deleted. A nested for-loop iterates through the 2-D array and plots the blocks.

Because some block types cannot be placed in free space, it is important that you build from the bottom up. When deleting (i.e. replacing all blocks with block type "Air") you need to delete from the top down. If you delete from the bottom up some bricks will fall before they can be deleted thus leaving a pile of rubble on the ground!

You should take a backup copy of your world before creating large structures like this as you will likely use the wrong coordinates. My 10 year old daughter Emily was very unhappy when I obliterated her village! Take a copy of the hidden `.minecraft` directory in your home directory (use `ls -A` to see all hidden files in a folder) plus also the `games` directory in the `mcp_i` directory.

MINECRAFT

PI EDITION



W. H. Bell

MagPi Writer

Interfacing Minecraft with PiFace Digital

SKILL LEVEL : INTERMEDIATE

Minecraft is a very popular game that has more recently been used as a teaching tool, to encourage programming. The Raspberry Pi version of Minecraft is available for free. The game is packaged with a Python application programmer interface (API), which allows interactions with players and blocks. An introduction to this API was given in the previous article. There are also additional teaching resources, such as Craig Richardson's "Python Programming for Raspberry Pi" book.

The interaction with Minecraft via the Python API is not limited to just software. Input/output (I/O) devices that are connected to a Raspberry Pi can react to, or produce events in Minecraft. This opens up a range of possibilities. For example, the garage door could open when the Minecraft player goes into the garage or the doorbell could be connected to a Minecraft chat message, etc. Since the Python API sends commands to the Minecraft server process over a network, the Raspberry Pi that is interacting with the Minecraft session could be in the garden monitoring the weather.

In this article, the Minecraft API is used with the PiFace Digital expansion board to create some traps around the selected player.

PiFace Digital

The PiFace Digital expansion board provides a safe way to connect digital devices to the Raspberry Pi, via buffered screw terminals.

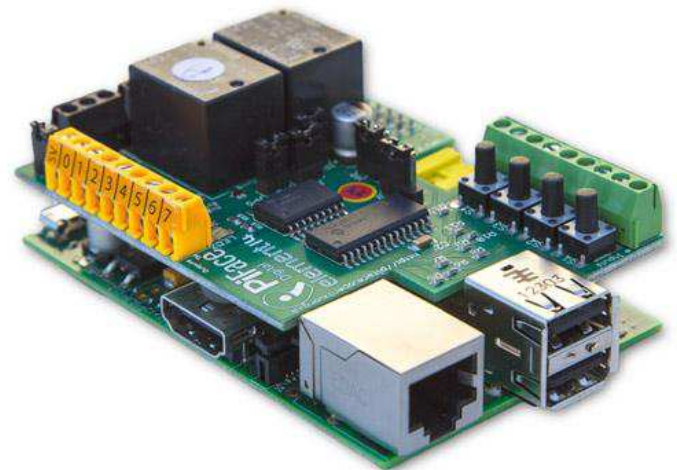

The board includes two relays that are suitable for low voltage applications, four switches, eight digital inputs, eight open collector outputs and eight LED indicators. The Raspberry Pi communicates with the PiFace via the SPI bus on the 26 pin header. There are Python and Scratch interfaces that are packaged for easy installation using the Debian package manager. More information on the PiFace can be found at: http://www.piface.org.uk/products/piface_digital/

PiFace Python interface

Starting from a recent Raspbian image, make sure that the Raspbian installation is up to date:

```
sudo apt-get update
sudo apt-get upgrade -y
```

Then start the raspi-config:

```
sudo raspi-config
```

Select the "Advanced Options" and choose "SPI". Then set the value to "Yes", select "Ok" and "Finish". (The Python library `python-pifacedigitalio` is already installed in the latest Raspbian image configuration.) PiFace example Python programs can be found in:

```
/usr/share/doc/python-pifacedigitalio/examples/
```

Installing Minecraft

If Minecraft is not already installed, then type:

```
cd $HOME
wget https://s3.amazonaws.com/assets.minecraft
.net/pi/minecraft-pi-0.1.1.tar.gz
tar zxvf minecraft-pi-0.1.1.tar.gz
```

```
import mcpi
from mcpi.block import *
import time

def sandTrap(mc):
    pos = mc.player.getTilePos()
    mc.setBlocks(pos.x-10, pos.y+15, pos.z-10, pos.x+10, pos.y+18, pos.z+10, SAND)
    mc.postToChat("Welcome to the beach!")

def volcanoTrap(mc):
    pos = mc.player.getTilePos()
    mc.postToChat("Warning.. volcano!")
    time.sleep(1)
    mc.setBlocks(pos.x, pos.y-50, pos.z, pos.x, pos.y-1, pos.z, LAVA)
    time.sleep(1)
    mc.setBlocks(pos.x-2, pos.y, pos.z-2, pos.x+2, pos.y+2, pos.z+2, LAVA)
    mc.postToChat("A bit too hot!")

def holeTrap(mc):
    pos = mc.player.getTilePos()
    mc.postToChat("Watch your feet!")
    time.sleep(1)
    mc.setBlocks(pos.x-2, pos.y-40, pos.z-2, pos.x+2, pos.y, pos.z+2, AIR)
```

Rather than copying the API files, the directory where the Python API is can be added to the `PYTHONPATH` variable. Use nano to edit the `.bashrc` file:

```
nano ~/.bashrc
```

Go to the end of the file and add:

```
# For Minecraft
MCPI_PY=$HOME/mcpi/api/python
if [[ -z $PYTHONPATH ]]; then
    export PYTHONPATH=$MCPI_PY
elif [[ $PYTHONPATH != *"$MCPI_PY"* ]]; then
    export PYTHONPATH="$PYTHONPATH:$MCPI_PY"
fi
unset MCPI_PY
```

Then save the file.

Minecraft traps

There are many actions that could be triggered by hardware input changes. In this article, some dramatic events that are centred on a given player are used.

Create a new file called `McTraps.py` in the present working directory. Add the Python code shown at the bottom of this page and save the file. Then open a second file called `mcControl.py` and add the Python code shown on page 38.

```

#!/usr/bin/env python
import mcpi
from mcpi.minecraft import Minecraft
import pifacedigitalio
from McTraps import *
import sys,time

class McControl:
    def __init__(self, ips):
        self.ips = []
        self.ips += ips

        # Open connections with the Minecraft sessions
        self.connections={}
        for ip in self.ips:
            try:
                #self.connections[ip] = Minecraft.create(ip)
                self.connections[ip] = None
            except:
                print("ERROR: cannot connect to Minecraft on %s" % ip)
                sys.exit(1)

        # Store the number of connections and initialise the current connection to be the first one
        self.connectionNumber = 0
        self.numberOfConnection = len(ips)

        # Setup an input event listener, one per switch on the PiFace
        pifacedigital = pifacedigitalio.PiFaceDigital()
        self.listener = pifacedigitalio.InputEventListener(chip=pifacedigital)
        for i in range(4):
            self.listener.register(i, pifacedigitalio.IODIR_ON, self.switchPressed)

    def listen(self):
        # Start listening to the PiFace
        self.listener.activate()
        print(">> Listening to PiFace")

    def shutdown(self):
        # Stop listening to the PiFace
        self.listener.deactivate()
        print(">> Listeners shutdown")

    def nextConnection(self):
        # Change to the connection associated with the next IP in the list.
        self.connectionNumber = self.connectionNumber + 1
        if self.connectionNumber >= self.numberOfConnection:
            self.connectionNumber = 0
        print(">> Using connection to %s" % self.ips[self.connectionNumber])

    def getConnection(self):
        # Return the connection associated with the selected IP
        if not self.ips[self.connectionNumber] in self.connections.keys():
            raise Exception("Error: no connection to %s" % self.ips[self.connectionNumber])
        return self.connections[self.ips[self.connectionNumber]]

    def switchPressed(self,event):
        # Handle switch press events:
        # (0) - If the first switch has been pressed, change to the next IP
        if event.pin_num == 0:
            self.nextConnection()
            return None

        # Get the current Minecraft connection
        mc = self.getConnection()

```

```

# (1-3) - Use the switch number to decide which trap to run
if event.pin_num == 1:
    print(">> Sand trap")
    sandTrap(mc)
elif event.pin_num == 2:
    print(">> Volcano trap")
    volcanoTrap(mc)
elif event.pin_num == 3:
    print(">> Hole trap")
    holeTrap(mc)
else:
    raise Exception("ERROR: pin number is out of range.")

if __name__ == "__main__":
    # If no command line options are provide, assume that the localhost is running Minecraft
    ips = []
    if len(sys.argv) == 1:
        ips += ["localhost"]
    else:
        ips += sys.argv[1:]

    # Start the MineCraft connections and PiFace listeners.
    # The listeners are shutdown went the program exits.
    mcControl = McControl(ips)
    try:
        mcControl.listen()
        while(1):
            time.sleep(1000)
    except KeyboardInterrupt:
        mcControl.shutdown()

```

Set the mcControl.py file as executable:

```
chmod 755 mcControl.py
```

Then use a new terminal window to start Minecraft, using the local Raspberry Pi:

```
cd mcpi
./minecraft-pi
```

Once Minecraft is running and a world has been created. Click on the tab key, to break the window focus. Then select the original terminal window and type:

```
./mcControl.py
```

By default, the program uses the localhost. To access one or more remote Minecraft games, type,

```
./mcControl.py 192.168.1.20 192.168.1.21
```

etc., where the IP addresses are the IP addresses of the Raspberry Pis running

Minecraft. The IP address of a Raspberry Pi can be found by typing,

```
ifconfig
```

in a terminal window.

Once the mcControl.py program is running, pressing switch 0 on the PiFace will cause the program to change the connection used for the tricks. This is useful when more than one Minecraft session is in the connection dictionary. Buttons 1, 2 and 3 run the sandTrap, volcanoTrap and holeTrap functions respectively.

To prevent a lot of CPU being used, the McControl class creates a InputEventListener object. This listener is then used to associate the switchPressed function with one of the four switches being pressed. Once the listener.activate() function has been called, the program continues to listen for PiFace switch changes until it is closed with CTRL-C.

MINECRAFT

PI EDITION



Dogie Lawson
MagPi Writer

Build QR Code structures inside Minecraft

SKILL LEVEL : BEGINNER

In this article I am going to show you how you can dynamically display QR codes inside Minecraft: Pi Edition. You can use these for many ideas - from displaying clues to puzzles in your Minecraft world to linking to websites. If you skipped them, I encourage you to read the other two Minecraft articles.

Getting started

If you have the latest version of Raspbian then Minecraft already comes preinstalled. If you do not have the latest Raspbian then let's get going by installing Minecraft and testing that it works.

Open an LXTerminal window and enter the following commands:

```
cd ~
wget https://s3.amazonaws.com/assets.minecraft.net/pi/minecraft-pi-0.1.1.tar.gz
tar -zxvf minecraft-pi-0.1.1.tar.gz
```

Make a note of `/home/pi/mcpi/api/python` as we will need that later. Test Minecraft with the following commands:

```
cd ~/mcpi
./minecraft-pi
```

You should get the familiar screen for Minecraft

and can build a new world. Have a play around and when you are done press `<TAB>` to get control of the cursor. We can switch to the LXTerminal window and close down Minecraft by pressing the `<CTRL>+<C>` keys together. We will come back to Minecraft later when we are ready to run the Python program that is going to build our structure in the virtual world.

Getting QR encoder and testing your first QR code

Although we could build our own QR code maker in Python, to keep things very simple and give us instant results we will use a ready built QR code generator called `qrencode`.

Open an LXTerminal and issue the following commands:

```
sudo apt-get install qrencode
qrencode -t ANSI "Hello World"
```

We have now got a QR code displaying in our LXTerminal window. You may need to stretch the window size so that the white borders at the top and bottom are visible. Get your smart phone and scan that QR code using any QR code app to prove that everything is working correctly.

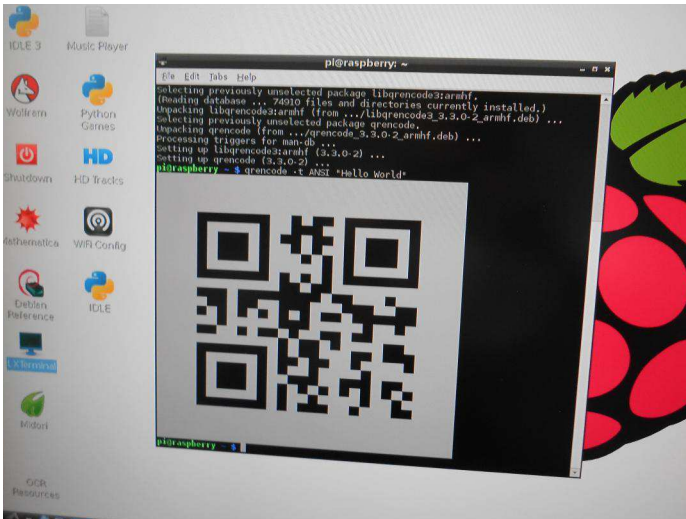

The qrencode program can generate QR codes in various formats. In our Python program we are going to generate an ASCII (plain text) format QR code and edit the output with the stream editor, sed. The qrencode program generates "##" for every black square and a space for every white square in the QR code, when we use the -t ASCII option.

Open an LXTerminal and issue the following complex command:

```
qrencode -t ASCII "Hello Minecraft" | \
sed 's/ / /g' | sed 's/##/#/g' > ~/mc.qr.txt
```

Note the two spaces in 's/ / /g'. We have now generated the data that will be the input for our Python program. Take a look at it with the cat command or use the Leafpad editor.

Glueing it all together

To build a QR code structure in Minecraft we are going to use the Python application programming interface (API). That allows us to control our Minecraft world with a program. For example, we can discover Steve's co-ordinates (Steve is the protagonist, i.e. your playable character) and we can teleport Steve from one location to another. We can also add or delete blocks in the world.

So, we have the data built from qrencode and sed and we have a method to read that data and

build some blocks in our Minecraft world. Let's look at the Python program to do this. The program is called mc.qr.py and I have stored it in a directory called python, inside the home directory.

First we import the sys package and add the API directory to the system path so that Python can find the Minecraft Python API packages. Note, please choose the correct path depending if you installed Minecraft or it came pre-installed:

```
#!/usr/bin/python
import sys
sys.path.insert(1, '/home/pi/mcpi/api/python')
#sys.path.insert(1, '/opt/minecraft-pi/api/python')
```

Now we can import the API packages to connect to the Minecraft world and build blocks:

```
import mcpi.minecraft as mine
import mcpi.block as block
```

Next we create a connection and get the current co-ordinates where Steve is standing:

```
mc = mine.Minecraft.create()
pPos = mc.player.getTilePos()
print "Player point:", pPos.x, pPos.y, pPos.z
```

Now move Steve (teleport him) twenty blocks back, forty blocks down and twenty blocks to his left and read his new position:

```
mc.player.setTilePos(pPos.x - 20, pPos.y - 40,
pPos.z - 20)
nPos = mc.player.getTilePos()
```

Open the input file generated by qrencode and read every line into an array:

```
qrc = open('mc.qr.txt', 'r')
arrayQR = []
for line in qrc:
    arrayQR.append(line)
qrc.close()
```

We then initialise the variables we use to position the blocks as we generate them in the Minecraft world:

```
print "Starting point:",nPos.x,nPos.y,nPos.z
x = nPos.x
y = nPos.y
z = nPos.z
```

The file generated by `qrencode` would come out upside down if we just worked from the first record to the last. So we need to read the last line first (to build the left hand line of blocks) and work backwards to the top (right hand line of blocks). Python has the `reversed()` function to read arrays from the last record to the first record. So each time round this FOR loop, the variable `i` is the line we are working on.

We set the starting position for the height of the block above Steve's position to the length of each record and work down while reading the line from left to right. Trust me, that gets the QR code turned through 90 degrees but it is not back to front. QR codes have the property that you can read them up, down, left or right (those three large squares in the corners tell the QR code reader how the code is oriented).

As we read the file, if the character is a space (white square) we build a block of snow (block id = 80) in the world. If the character is a hash (black square) we build a block of obsidian (block id = 49). You can find the block id codes on the Minecraft Wiki at http://minecraft.gamepedia.com/Data_values/Block_IDs:

```
for i in reversed(arrayQR):
    y = pPos.y + len(i)

    for j in range(0, len(i)):
        if (i[j] == " "):
            block = 80
        if (i[j] == "#"):
            block = 49
        y = y - 1
        mc.setBlock(x, y, z, block)
        x = x + 1
```

Finally we teleport Steve back to his original position:

```
mc.player.setPos(pPos.x, pPos.y, pPos.z)
```

Display the QR code in Minecraft

To get everything running we need to start Minecraft then when it is running we start our Python program. So we need two LXTerminal windows. In the first LXTerminal window enter the following commands:

```
cd ~/mcpi
./minecraft-pi
```

Login to your Minecraft world and find an area without too much terrain (we don't want trees blocking our view). Then press the `<ALT>+<TAB>` keys together to switch to the second LXterminal window. In that second window enter the following commands:

```
cd ~/python
chmod 755 ./mc.qr.py
./mc.qr.py
```

The screen will go blank because the last few blocks are built on top of Steve! When it is done drive round to find your QR code in the Minecraft world. I found I needed to build a tower of stone (or dirt) to get Steve positioned so that the QR code was square on and filled the top half of the screen without any keystoneing effects. I was then able to scan it with my smart phone.



I'd like to thank Konrad, my 14 year old son and Minecraft expert, for his patience and advice. I started building the code with diamond (block id = 57) but Konrad suggested using snow for better contrast.

Thanks to our maker friends for the best stuff from the corners of the earth*

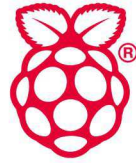

*and Sheffield

<http://shop.pimoroni.com>

海賊口ポ忍者さる
Made in Sheffield, UK
<http://pimoroni.com>



Use code "LANDLUBBER" during checkout for 10% off orders placed before January 31st, 2015!



GEMMA Wearables Kit



SparkFun Inventor's Kit

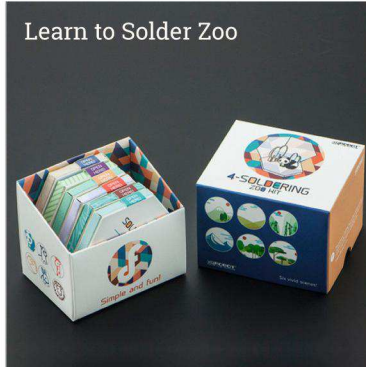

Learn to Solder Zoo



Display-o-tron 3000



Pirate Corkscrew

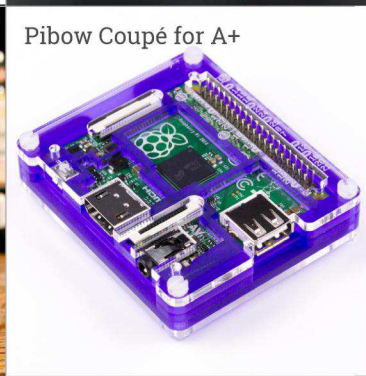

Pibow Coupé for A+

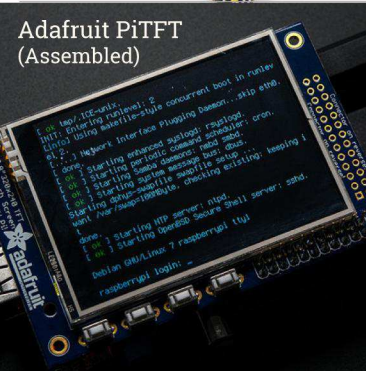

Adafruit PiTFT (Assembled)



Chirp Plant Watering Alarm

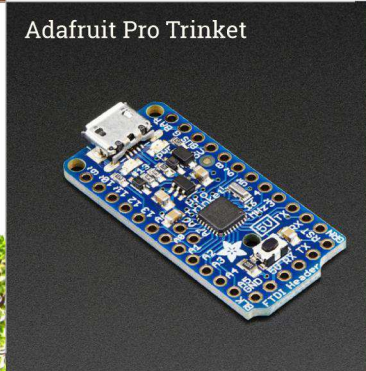

Adafruit Pro Trinket

HATs
Pibows
Widgets
Arduinos
Dead Trees

We now stock a massive range of shiny things!

More stuff to make your things than ever.

<http://shop.pimoroni.com>

海賊口ポ忍者さる
Made in Sheffield, UK
<http://pimoroni.com>





Amy Mather

The future of young hackers?



Adrian Harper
MagPi Writer

In the unlikely case that you haven't already seen the video and don't know the name Amy Mather, I would like to introduce you to a young lady who hosted, quite possibly, the highlight presentation of the 2013 Manchester Jamboree, and who certainly has a bright future ahead of her in computer science.

Amy's Game of Life presentation is available on YouTube (<http://tinyurl.com/amyjamboree>) and I would encourage you to watch the video first and then come back to read the remainder of this MagPi article.

After watching the first time I was astounded at Amy's confidence and ability and I had to watch it a second time. I couldn't help but think that Amy is a shining example of what all our kids could be if they are given the right resources, teaching and encouragement to experiment without fear.

[MagPi] Most people have watched your presentation and have been astonished by your achievements with the Raspberry Pi, what has been the feedback from that video?

[Amy] The feedback from the Jamboree video has been amazing, with people asking me to do more talks at other conferences, interviews such

as this and even a request to design a website! There have been so many lovely comments from people that I've never met - I'm really grateful to Alan O'Donohoe for giving me the opportunity to speak. I was so surprised when I was asked to talk alongside the likes of Steve Furber and Rob Bishop!

[MagPi] How did you first come across the Raspberry Pi?

[Amy] My Mum found out about the Raspberry Pi on Twitter and ordered one for me on the day of release. It took a few weeks to arrive but as soon as I got hold of it I took it to Ben Nuttall's first Manchester Raspberry Jam. There I improved upon my Scratch version of Pacman (<http://bit.ly/L51Ycg>) using a photograph of my face as the Pacman sprite plus I made a bat game for my little brother.

[MagPi] Before the Raspberry Pi came along, what was your experience with computers and electronics? Did you work with other platforms?

[Amy] After Alan's first Hack to the Future in February 2012 a very generous geek sent me an Arduino kit through the post. I had a school homework project to do at the time which was to make and label a volcano for geography, so I

decided to incorporate my Arduino into that! When it was finished I was asked to demonstrate it at MadLab in response to a 'call for makers' for the Manchester Mini Maker Faire that was being held a couple of months later. Around the same time I attended a Manchester Girl Geeks workshop that introduced me to Codecademy. I loved it so much that I went home and carried on... I've now got 50+ badges and have worked on CSS, JavaScript, Python, PHP and HTML5 courses.

[MagPi] Obviously you are quite the accomplished programmer now. What was your first project with the Raspberry Pi?

[Amy] My first project on the Raspberry Pi was a guessing game in Python. It used the 'random' library to choose a different number each time for the answer and you had to guess which number had been picked. It told you if your answer was too big or too small and deducted points each time you got it wrong. If you got one of the best scores then it asked you for your name and saved it to a high scores list.

[MagPi] No matter the country, there are often articles in the press about the poor IT and Computer Science teaching in schools. How have you found this to be in your case? Is there much interest in gaining a deeper knowledge of computer science with your friends and classmates?

[Amy] No, most of my friends at school use a bit of HTML to update their Tumblr blogs and have done Scratch, Alice and Dreamweaver in ICT lessons, but they don't really seem to want to take it any further. I think that if the Raspberry Pi and Arduino were incorporated into ICT lessons (e.g. introduction to Python from age 11), Textiles lessons (e.g. Arduino Lilypad) or Product Design / Resistant Materials lessons (e.g. robots) then that could show them that programming can actually help you create some pretty awesome stuff. Hopefully that would be enough to inspire them to start hacking and coding their own projects outside of school.

[MagPi] Are there Raspberry Pis available in your school already?

[Amy] No, unfortunately there aren't any Raspberry Pis in my school at all, but I'd like to change that ;)

[MagPi] What more can we do as a community to get more young people, both boys and girls, into computer science? How could our readers get involved?

[Amy] I think that we need to set up more community hackspaces, or places like MadLab, that welcome kids through their doors. Readers could set up these kid friendly spaces and run events specifically for under 18's like MadLab's CoderDojos or set up code clubs in their local primary schools (<http://bit.ly/HLRWwT>). Your local STEMnet team (<http://bit.ly/B0z2q>) could help with setting this up if you're unsure.

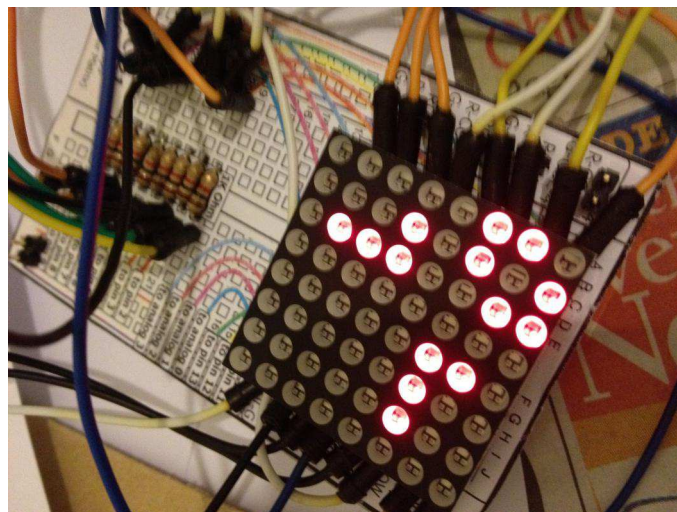

Raspberry Pi to Arduino to LED matrix. Amy is not limited to software hacking!

[MagPi] If you were able to influence the Raspberry Pi design team and introduce a new model, what changes would you bring to the table?

[Amy] I wonder if it would be a good idea to attach a 16x2 LCD screen to the board, so that once you've written your code for a project and it's on the Pi, you could then just plug in a keyboard and a terminal-like environment would come up on the LCD screen. This would mean

that you could run your code without having to plug in a monitor, making it easier to incorporate into projects. I would also like to see if the design team could introduce a new board that could be used in wearable electronics, along the lines of an Arduino LilyPad but even better! I like the fact that the LilyPad is washable, lightweight and can be easily attached to fabric with conductive thread. If they could improve upon this it would be great!

[MagPi] What are the best resources out there that you can recommend for young Raspberry Pi programmers, or people in general that are giving programming a go for the first time?

[Amy] Obviously, the MagPi magazines are a great resource :) but I think that the Super Scratch Book (<http://bit.ly/MVKOw8>) looks like a great book to help younger users of the Raspberry Pi. For older users Simon Monk's Python book (<http://bit.ly/VXJZrl>) provides a great introduction to the language. There are some very helpful resources online - I really like;

GeekGurlDiaries: <http://bit.ly/1088jKG>
Adafruit: <http://bit.ly/LEQbiB>
MakeZine: <http://bit.ly/13Xr44a>
Instructables: <http://bit.ly/4kLr49>
Arduino Tutorials: <http://bit.ly/vfm8A>

The Twitter feeds @mykidcancode and @codingforkids often have great links, too.

[MagPi] Conway's Game of Life can be quite daunting. What projects would you encourage new young programmers to begin with?

[Amy] Scratch (<http://bit.ly/y4Mw>) is probably the best place for young programmers to begin, but if you prefer working towards goals then Codecademy (<http://bit.ly/oDjwOj>) will probably be more helpful. On the Codecademy website you can choose to learn a particular language or work on a project e.g. one of the first games you'll make in the JavaScript course is Fizz Buzz. Alternatively, simple guessing games or rock-paper-scissors type games are a good place to start and there are plenty of internet forums

where you can search for help with any queries that you may have.

[MagPi] In your presentation you mentioned Madlab and Manchester Hackspace. Can you tell us a little about these resources and the benefits you get from going there?

[Amy] Without MadLab (<http://bit.ly/rrahU>) I wouldn't be talking to you today! They are AWESOME!!!! I've met so many great people there who are always willing to share their knowledge and teach me new things. At MadLab I have met: Mike Little, who was my mentor for YRS2012, Ben Nuttall who runs the Manchester Raspberry Jam (<http://bit.ly/YUE2yY>), Alan O'Donohoe who organised the Raspberry Jamboree, John Beckerson a senior curator from Manchester's Museum of Science and Industry who invited me to display at the Mini Maker Faire, Dr Lucie Green who is a space scientist, plus lots and lots of other very kind people who have taught me so much. I've also been to lots of workshops held by Manchester Girl Geeks (<http://bit.ly/PYsHEL>) and have started helping to teach at their workshops - there's just so much going on there! Bob Clough from HacMan (<http://bit.ly/jGLhtz>) showed me how to use Inkscape to control the laser cutter when I was making the case for my 'Conway's Game of Life on Pi'. All the people at the hackspace are happy to help people with any problems that they may have - I wish there was a MadLab/HacMan in every town to help other children discover their inner geek!



Amy shares her knowledge by teaching others.

[MagPi] Are there many other kids around your age going to the hack spaces on a regular basis? Can you tell us about the type of projects they are working on?

[Amy] At MadLab's U18 CoderDojo there's always lots of different activities going on. For example there's a MaKey MaKey kit which most of the younger children love making banana pianos with (<http://bit.ly/KkiMLO>), a Lego WeDo kit (<http://bit.ly/12wCqup>) and Bare Conductive inks were bought for the last event (<http://bit.ly/16r9C3>). The events are always fully booked and there are always volunteers around who can teach the children Scratch, Python, PHP, Minecraft plus a variety of other skills. At the last event, the Minecraft table all worked together making fireworks and they demonstrated their display at the end.

[MagPi] You already have access to some nice gadgets such as laser cutters and 3D printers. What technologies are on the horizon that excite you?

[Amy] I love the idea of conductive inks. I met Dr Kate Stone (<http://bit.ly/5y6TPI>) at the YRS Festival of Code last year and she showed me a pair of headphones that were made from paper, some electronic greetings cards that she'd made and also this jazz poster (<http://bit.ly/17YXxZA>). It was amazing to see what she'd achieved with the technology. My mum bought some of Bare Conductive's products at the Maker Faire UK recently and I can't wait to try out the conductive paint!

[MagPi] We're often asked by parents if their kids are old enough for a Raspberry Pi. Given your experience, what do you think is an ideal age for kids to be introduced to programming and do you think the tools available are adequate?

[Amy] I don't think that there is a minimum age; if a child can read and type, then they can learn to code!

[MagPi] As parents, what can we do, apart from buying a Raspberry Pi obviously, to spark our children's interest in computing?

[Amy] There are a couple of computing festivals in the UK - #Include in Warwickshire that is aimed at 11-13yr olds and Silicon Dreams in Leicestershire in July. Also, during the summer holiday in August, Young Rewired State (<http://bit.ly/eAtCMI>) is an event with centres throughout the country holding a week-long workshop, where children up to 18 years old spend 5 days working with mentors on a project, using openly available data sets. Then, at the weekend, all the teams meet up in Birmingham for the Festival of Code where they present their projects.

[MagPi] Finally, what new projects are you working on at the moment? Are you able to give us a sneak peek?

[Amy] I've been offered a touch screen and larger LED array which, when they arrive, I will add into my 'Game of Life on Pi' to show at the Manchester Mini Maker Faire this summer. Another idea is a 'T-Shirt of Life' which would be a T-shirt made from recycled materials with LEDs sewn on the front in a grid formation, which would display the Conway's Game of Life. What I'd really love to see though, is a Maker Faire exclusively for U18's - it could be called the Mini Makers Faire! It would be great if it were run like YRS with a week-long workshop beforehand using Hack Spaces and FabLabs with volunteer mentors and then at the weekend the children would present what they've made at the Mini Makers Faire. If anybody out there would like to help me do this, please get in touch!

Amy is a prime example of why we should be getting Raspberry Pis into the hands of as many kids as possible! It is young people like her that provide inspiration and drive to those within the Raspberry Pi Foundation, The MagPi, and the wider community, to keep doing what they're doing.

This certainly won't be the last time you hear of Amy in The MagPi. She is currently working on a number of articles for the magazine to help us encourage and challenge our younger readers.

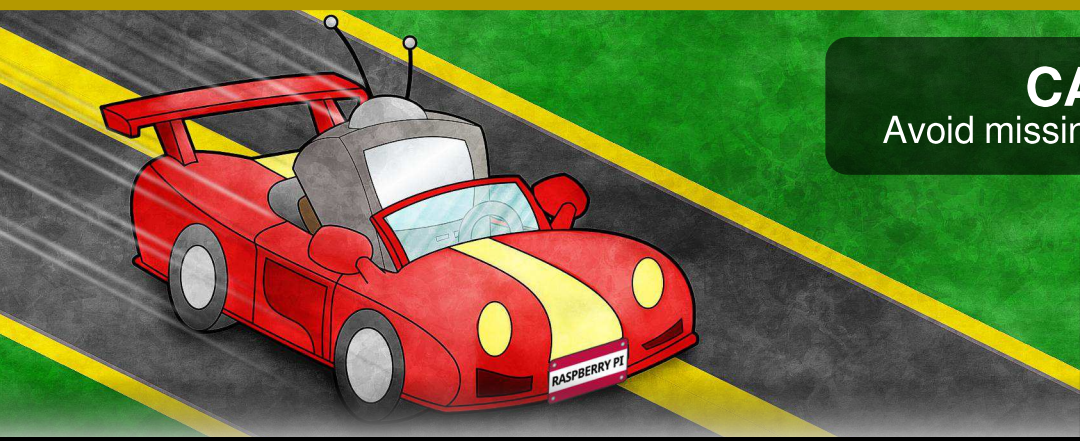

CATCH-UP TV

Avoid missing your favourite programme

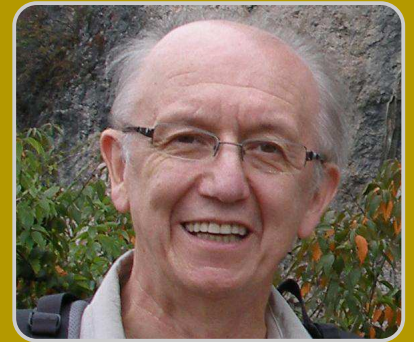

Geoff Harmer

Guest Writer

How to configure OpenELEC so you can watch TV programmes

SKILL LEVEL : BEGINNER

Do you want to watch TV programmes using your Raspberry Pi?

- No need to buy a smart TV to get your HDTV to connect to catch-up TV services such as BBC iPlayer and ITV Player in the UK, or CTV and Space and Bravo in Canada, or RTE1 and RTE2 in Ireland or Network10 in Australia.
- No need to have your Raspberry Pi keyboard and mouse and their cables spoiling the look of your HDTV.
- Use a Raspberry Pi with a Wi-fi USB dongle running OpenELEC - a compact, high performance Linux distribution that has XBMC media centre software installed - and then hide the Raspberry Pi behind the HDTV.
- Use a remote control app on your Android, iOS or Blackberry smartphone to control XBMC via your home Wi-fi so you can select and watch catch-up TV programmes on your HDTV.
- No Linux commands are needed to install or use OpenELEC with the Raspberry Pi.

My style of television watching over the last few years has switched from live viewing and recording, to predominantly using catch-up TV. Catch-up TV is particularly helpful when a missed programme gets a good review the next

day from friends or from TV reviews in newspapers or on the web.

I am going to show you how to install catch-up TV services using XBMC and the OpenELEC distribution on a Raspberry Pi to work with your HDTV. It takes about 60 minutes to set up and requires no use of Linux commands either!

Permanent components

- Any Raspberry Pi.
- Good quality 5V power adapter for the Raspberry Pi (minimum 700mA or greater).
- HDMI cable to connect the Raspberry Pi to your HDTV.
- Wi-fi nano USB dongle if you do not have easy access to a wired internet connection (the Wi-fi dongle from <http://www.thepihut.com> uses built-in drivers and does not require a powered USB hub).
- 8GB+ SD card loaded with the latest NOOBS software from <http://www.raspberrypi.org>.
- Android, iOS or Blackberry 10 device with a downloaded app to remotely control XBMC, e.g. XRMT for Blackberry 10 OS, or Official XBMC Remote for Android, or Official XBMC Remote for iOS.

Note: On a Model A/B the USB ports may not be able to supply enough current for certain Wi-fi dongles. This can result in video stuttering. If you have a good connection, the solution is to use a powered USB hub with a minimum 2A power supply, or use a Model A+/B+. Some hubs will also back power the Raspberry Pi so you only need one power supply. Check http://elinux.org/RPi_Powered_USB_Hubs for a list of good hubs.

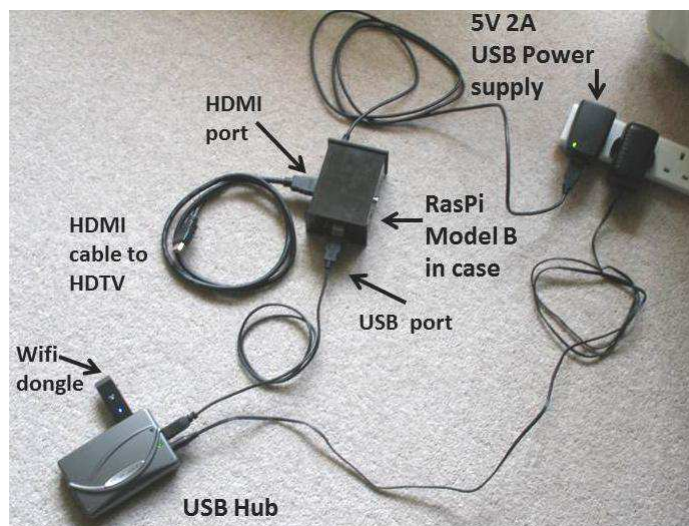

Installation instructions

Step 1. Get NOOBS

Copy the latest NOOBS distribution onto a 8GB+ SD card. When finished insert the SD card into the Raspberry Pi, plug in the Wi-fi USB dongle and use a HDMI cable to connect the Raspberry Pi to your HDTV. The first time you start NOOBS you will be asked to choose what operating system to install. Choose OpenELEC. This will take a few minutes to install, after which you can reboot your Raspberry Pi.

Step 2. XBMC and networks

Note: If you are using a Raspberry Pi Model A/A+ then for this section you will temporarily need to use a powered USB hub so you can connect both the Wi-fi dongle and a mouse.

After your Raspberry Pi has started, XBMC will present its main screen known as Confluence (blue bubbles background) followed by an initial

setup wizard. Here you choose your region, provide a friendly network name then choose from a list of available wireless connections. You will need to know your wireless connection name and security passphrase.

By default your network IP address and DNS servers will be automatically configured. However you may want to change the DNS servers to watch overseas programming using services like <http://www.unblock-us.com>, or you may want to change the IP address to use a static IP. If you want to change the network settings later, from the main screen select SYSTEM, OpenELEC and then click on Connections. Click on your connection and choose Edit from the pop-up menu.

A static IP address tends to be more reliable because it remains fixed and so the remote app on your smartphone will always connect. The IP address created using DHCP can vary depending on what other devices are connected to the broadband router.

Setting up a static IP (optional)

Choose to Edit your connection, as described above and click on IPv4. You will see the IP Address Method is currently set to DHCP. Click on this and change it to Manual. Now click on IP Address and enter an unused address within the range permitted by your broadband router e.g. 192.168.1.50. You can leave the Subnet Mask (e.g. 255.255.255.0) and Default Gateway (e.g. 192.168.1.254) at their default settings.

To change the DNS settings for your connection choose DNS servers. You will see options to enter IP addresses for up to three nameservers. By default these will already have the IP addresses of the DNS servers from your internet provider, but you can choose to use others. For example OpenDNS provides enhanced security using its own free to use DNS server IP addresses at <http://www.opendns.com>. [Ed: /

changed these to the Unblock-Us DNS servers so, as an ex-pat, I can still watch BBC iPlayer content in Canada].

At this point it is a good idea to click the Power button on the main screen and reboot the Raspberry Pi. When OpenELEC restarts you should have a working network connection.

Step 3. Other important XBMC features

1. Is the display too large for your screen or do you see a black border? To change the screen size select SYSTEM then Settings and click on Appearance. In the Skin section, change Zoom (up and down keys) to set an appropriate reduction.

2. Stop RSS feeds across the bottom of the Confluence screen. From the Confluence screen select SYSTEM then Settings and click on Appearance. In the Skin section click on Show RSS news feeds to turn it off.

3. To allow remote wireless control of XBMC select SYSTEM then Settings and click on Services. In the Webserver section click on Allow control of XBMC via HTTP to turn this option on. Note the default username is xbmc with no password. You can optionally change these. In the Remote control section click on Allow programs on other systems to control XBMC.

4. To ensure OpenELEC has your home workgroup from the main screen select SYSTEM then Settings and click on Services. In the SMB client section the Workgroup option is set to WORKGROUP by default. If your home network has its own workgroup name then you must change WORKGROUP to your home workgroup name. You can find out your home workgroup name from your Windows PC by opening the Control Panel, open the System and Security category then click on System. The workgroup is shown near the bottom.

Step 4. Install TV catch-up files

Add-ons need to be added to XBMC in order to use catch-up TV. Here are some examples that have been tested to work.

UK & Ireland:

BBC iPlayer

<http://code.google.com/p/xbmc-iplayerv2/>

ITV player

<http://code.google.com/p/xbmc-itv-player/downloads/list>

Channel 4 On Demand

<http://code.google.com/p/mossy-xbmc-repo/>

Irish TV

<http://code.google.com/p/mossy-xbmc-repo/>

Canada:

<https://github.com/irfancharania/canada.on.demand.repo>

Australia:

<http://code.google.com/p/xbmc-catchuptv-au/>

The Canadian add-in is particularly good as it covers 20 stations, but just like the BBC and ITV add-ins, it is region locked. Fortunately Australia's Network10 and Ireland's RTE stations appear to be freely available to all.

Using your PC, copy the latest zip files onto a USB memory stick without unzipping them. Now plug the USB memory stick into the USB port of your Raspberry Pi and power-up the Raspberry Pi. To install these add-ons, from the main menu select VIDEOS then Add-ons and click on Get More. At the top of the list click on .. (i.e. two dots). At the top of the next list again click on .. (i.e. two dots). Now click on Install from zip file. A new window will pop-up. Select your USB memory stick. If it is not visible remove it and insert it again.

Navigate to the first add-on you wish to install and click it. It gets installed at this point within about 30-40 seconds but it is not obvious. You will be returned to the Install from zip file menu and you may momentarily observe (bottom

right of the screen) that the new add-on has been installed. Check by returning to VIDEOS and selecting Add-ons and you should see the name of the add-on you just installed. If it is absent, wait a few minutes for it to appear and if it is still absent then reboot your Raspberry Pi. Repeat for each add-on, one at a time.

Step 5. XBMC remote control

Download and install the Official XBMC Remote app to your Android or iOS device, or install XRMT for your Blackberry 10 OS device.

As an example, here is how to configure XRMT on your Blackberry 10 OS device. Once installed open the app and click the three dots icon (bottom right) and select Add Server. For Server name enter `openelec` (lower case). For Server IP address enter the address that you set up for the Raspberry Pi in step 2 on page 49. Leave the Port code as `9090` then click the icon at bottom left.

Now scroll down from the top of the app, click on Settings and change the Auto connect by clicking on `openelec` below it. Close the settings screen. The app is now ready to use.

Once you have installed an XBMC remote app on your smartphone you are ready to control XBMC without a mouse or keyboard. Simply use the remote control app to navigate the XBMC Confluence screen, select VIDEOS and then select Add-ons. Your add-ons will be displayed. Simply click on an add-on such as iPlayer to run it. Enjoy the catch-up TV programmes.

Interesting extra facts and tips

HDMI connections

Are all the HDMI sockets on your TV in use with other devices such as a PVR, bluray player and games console? Not enough HDMI sockets on your TV for your Raspberry Pi? The solution is to use a 2-in/1-out HDMI switch (e.g. Belkin). Thus both the Raspberry Pi and the other device are

connected to the HDTV. The Belkin product has a button on it for selecting which of the 2 inputs to currently use.

XRMT connection issue

If you have been using a mouse to control XBMC, you may find that your Blackberry XRMT won't connect. Unplug the mouse and reboot the Raspberry Pi and then XRMT should connect.

Command line access

Do you want to access the OpenELEC operating system with Linux commands from your Windows PC? You can do this using a program called PuTTY. PuTTY uses the SSH protocol to connect to the Raspberry Pi. Download the latest version of PuTTY from <http://www.chiark.greenend.org.uk/~sgtatham/putty/download.html>.

You also need to set OpenELEC to allow a SSH connection. From the XBMC main screen select SYSTEM then OpenElec and click on Services. Select the SSH option and click to enable it. Reboot the Raspberry Pi. Once PuTTY is installed on your Windows PC simply run the file `putty.exe`. After the PuTTY screen has opened enter the IP address of your Raspberry Pi. Leave the Port as 22 and choose SSH as the connection type. Click on Open then enter the username and password. For OpenELEC the default username is `root` and the default password is `openelec`.

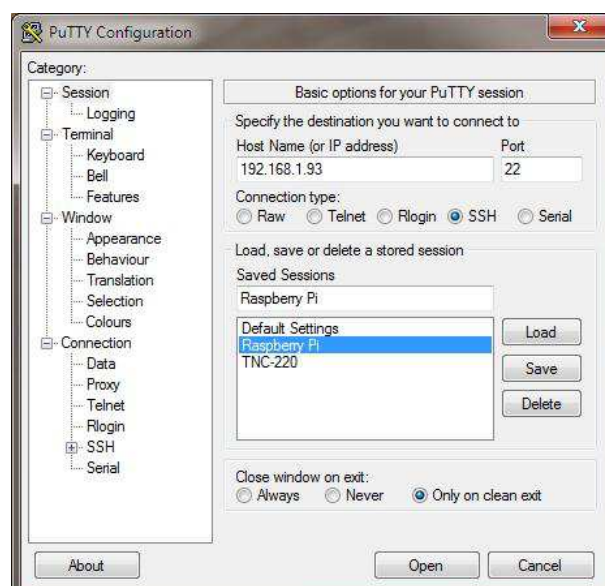



Discover new radio content across the world

SKILL LEVEL : INTERMEDIATE

A few years ago I hacked a network router to become an internet radio device by putting OpenWRT on it and adding a USB sound card. At that time this setup was the only way I could figure out how to make an intelligent box that connected to the internet at one end and output music at the other. That system, located in our kitchen, is still in use, but when we got a new stereo in the living room it was time to revisit the internet radio situation.

The Raspberry Pi has all the necessary hardware on board to enable wired or wireless internet connectivity, plus analogue and digital sound output. Having decided on the hardware, some research on the web resulted in the following strategy for the software.

- Use the music player daemon `mpd` for sound
- Control it with the music player controller software `mpc`
- Use `apache2` to serve a web interface with forms and `cgi-bin` functionality to select radio channels from the playlist
- Display what is currently playing
- Shutdown the Raspberry Pi gracefully via the web interface.

The last option proved to be tricky, but more on that later.

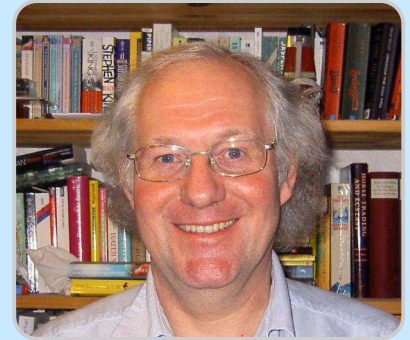

Volker Ziemann

Guest Writer

There is no hardware work involved in this approach, only some programming. The end result is a system that can be controlled from any computer, smartphone or tablet device with web access to the Raspberry Pi.

For the software approach I used Raspbian from the latest release of NOOBS. You can download this from <http://www.raspberrypi.org/downloads>. I assume that you already have your Raspberry Pi connected to your network, either by cable or wireless. If not, wired ethernet normally works out of the box, if you have a DHCP server on your network. Most routers offer this by default. If you have a wireless network (and a USB wireless network adapter for your Raspberry Pi) the easiest way to connect is to start the LXDE window interface by typing `startx` on the command line and then run `WiFi Config`, which you can find on the desktop.

Once you are connected to your network, you need to find out the IP address of your Raspberry Pi. From the command line, enter:

```
ifconfig
```

This will display the settings for each network adapter. Find the line that starts with `inet addr` and the four numbers that follow (e.g.

192.168.1.97) is the IP address of your Raspberry Pi. You will need this later when controlling the radio from your smartphone, etc. If you are connected by both cable and wireless, `ifconfig` will list two interfaces - `eth0` and `wlan0`. The IP address of either network interface will work for the internet radio.

Now we proceed by installing the required packages. From the command line, enter:

```
sudo apt-get update
sudo apt-get install mpd mpc apache2
```

Once installed, for good measure I suggest you shutdown then reboot the Raspberry Pi. If you do not use the HDMI cable for sound to your monitor then, while the system is shutdown, it is a good time to connect the Raspberry Pi to some active loudspeakers with a built in amplifier. Alternatively, you can connect it to the Aux/Line In input of your stereo amplifier. For this you might need a cable that has a 3.5mm jack connector attached to the Raspberry Pi audio output and RCA/phono connectors that are attached to the amplifier.

It is time to test the basic software functionality. The `mpd` program is a daemon (background process) that is started automatically at boot time. We interact with the daemon using the `mpc` program.

In order to play the radio stations we need to inform the Raspberry Pi about the channels. For this I prepared a small text file that contains the internet addresses of the radio stations I want to listen to, one station per line, with the URL and port number separated by a colon. Using either Leafpad in LXDE or `nano` from the command line, create a sample file with the following,

```
http://108.61.73.118:8030
http://109.123.116.202:8022
```

and save it as `playlist.txt` (the actual name does not matter - just pick any you prefer). We can now add our stations to the `mpc` playlist. From the command line, enter:

```
cat playlist.txt | mpc add
```

To check that the playlist was added, enter:

```
mpc playlist
```

This will list the stations by their URL, or by their name if they have been played.

Let's make some noise! To play the first station in the playlist enter,

```
mpc play 1
```

and to play the second station enter:

```
mpc play 2
```

Normally the `play` command connects to the radio station in less than two seconds and should result in some music. The first station is a classic rock station, "181.fm - The Eagle" while the second station is a classical music station, "Venice Classic Radio Italia". Look on the taskbar and notice how little CPU is being used (approximately 10%).

To display the current station plus the current artist and song being played, enter:

```
mpc current
```

To stop listening to internet radio, enter:

```
mpc stop
```

These are just the basic functions. For more details enter the following:

```
mpc help
man mpc
```

You can find a long list of internet radio stations at the following locations:

<http://www.listenlive.eu>,
<http://www.sky.fm>,
<http://www.internet-radio.com> and
<http://www.radio-locator.com>.

Check them out and listen to the diversity. To get the required URL look for the streaming file format as used by Winamp, iTunes, VLC and hardware players. This is typically a *.pls file. Download the *.pls file, open it in a text editor and view the URL. Add the URL of your favourite stations to the `playlist.txt` playlist file.

[Ed: Here are some stations from Canada, the Netherlands and the UK to get you started.]

```
http://pub7.sky.fm:80/sky_uptemposmoothjazz
http://pub6.sky.fm:80/sky_tophits
http://ice-the.musicradio.com:80/HeartLondonMP3
http://8573.live.streamtheworld.com/SKYRADIO_SC
http://8343.live.streamtheworld.com/CHQMFMAC_SC
```

At this point you could take a shortcut and install for example "mpdroid" on your Android device or "MPoD" on your iOS device and remotely control the mpd daemon on your Raspberry Pi. You would get some functionality, but miss out on the fun of learning some HTML and cgi-bin controls of your Raspberry Pi.

HTML

At this point the basic audio functionality is established and we need to add the control interface, which is provided by the apache2 server. Using the IP address of your Raspberry Pi that you determined earlier, using any computer on your local network, including the Raspberry Pi itself, start a web browser and enter the IP address of your Raspberry Pi into the address line. You should receive a message that says:

It works!

This is the default web page for this server.
The web server software is running but no content...

This means that your apache2 web server is running, which it should do automatically after installing it - if you followed the instructions.

The web server basically dishes out web pages which are located on the Raspberry Pi. The page you were just shown is actually a file named `index.html` that resides in the directory

`/var/www/` by default. You can change that location by altering the apache2 configuration files, but I have assumed you will use the default configuration that came with the installation, as I do. Note that you need root permission to put files there; use `sudo` before each command.

We need to replace the `index.html` file with another one that provides the internet radio interface. I will show you how in a minute, but here is a screenshot of what I ended up with.

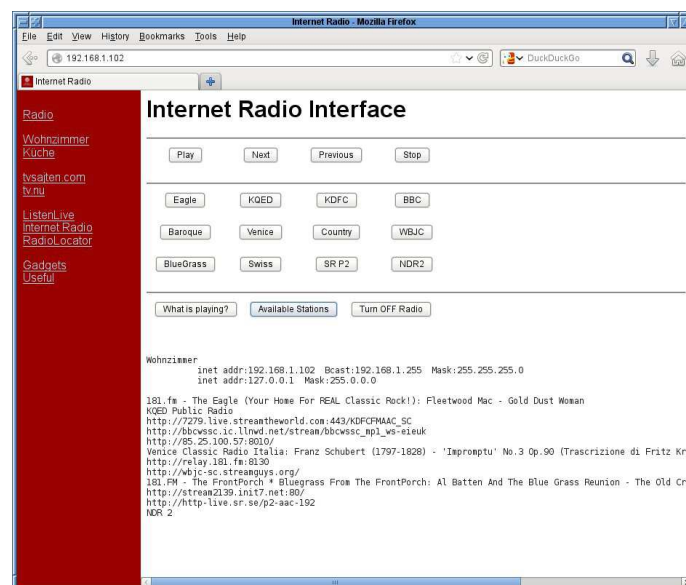

On the left hand side there is a red area with several useful links like the different internet radios scattered in my household, links to Swedish TV programmes, links to sites with internet radio stations and other useful things.

On the right hand side, in the upper half of the screen, there is the radio interface with buttons to start and stop listening plus move to the next or previous station. Below that there are twelve buttons for the twelve radio stations in my playlist file `playlist.txt`. The three buttons in the bottom row - "What is playing?", "Available Stations" and "Turn OFF Radio" - are self-explanatory.

Finally, below the buttons is a status area where the information from the button presses is displayed. In the above example I pressed the "Available Stations" button and the twelve links are displayed.

Having described the interface, we now turn to the implementation. To set up the main window we divide it into three parts; the left red sidebar, the button interface and the status display. I use HTML framesets. The `index.html` file that replaces the default one in `/var/www/` looks like:

```
<html>
<head>
  <title>Internet Radio</title>
</head>
<frameset cols="170,*" frameborder="0" framespacing="0"
  border="0">
  <frame src="indexlist.html" name="index">
  <frameset rows="50%,50%" frameborder="0"
    framespacing="0" border="0">
    <frame src="radio.html" name="main">
    <frame src="status.html" name="status">
  </frameset>
</frameset>
</html>
```

The head contains just the title information. Then there are two nested framesets. The first contains a frame with a file named `indexlist.html`, which contains the content in the red sidebar. The second frameset contains two frames, one for the radio interface, `radio.html`, and one for the status page, `status.html`. The frameset instructions contain specifications of the sub-division of the page. The first frameset sub-divides the page into two parts, where the red sidebar will be 170 pixels wide and the rest is given to the second frameset. The second frameset splits its allocated space evenly between two frames with the radio and the status. Note that the frames have names, which we will later use to direct output to the proper places.

The file `indexlist.html` file that describes the red sidebar on the left is shown here:

```
<html>
<body bgcolor=#990000 text=white link=white
  vlink=lightblue>
  <br>
  <a href="radio.html" target=main>Radio</a>
  <br>
  <br>
  <a href="http://192.168.xxx.xxx/" target=blank>Kitchen</a>
  <br>
  <a href="http://192.168.xxx.xxx/" target=blank>Living</a>
  <br>
  <br>
  <a href="http://www.listenlive.eu/" target=blank>
    ListenLive</a>
  <br>
  <a href="http://www.internet-radio.com/" target=blank>
    Internet Radio</a>
  <br>
  <a href="http://www.radio-locator.com/" target=blank>
    RadioLocator</a>
</body>
</html>
```

We see the usual header and body directives,

where the red background is defined. Then there is a list of HTML anchors with the links to the respective web pages. Note that the anchors have a target directive, which directs the browser when you click the link to either a new window with `target=blank`, or to a named frame with `target=main`. The main frame is the radio area. We will use this feature later to direct output to the status section of the page.

The status page is rather trivial. It just contains the opening and closing html and body directives and some dummy text. This will be overwritten dynamically later.

CGI-BIN

The file `radio.html` contains all the fun interactive stuff. This is where the interaction with the Raspberry Pi actually takes place. The interface is built as a horizontal table sandwiched between `<TR>` and `</TR>` tags. Each entry in the table is declared between the `<TD>` and `</TD>` tags. In between these tags a `<FORM>` is defined that executes an action on the Raspberry Pi, as defined by the instruction `action="cgi-bin/play.sh"`.

```
<html>
<head>
  <title>Internet Radio</title>
</head>
<body>
  <h1>Internet Radio Interface</h1>
  <hr>
  <table border="0">
    <tr>
      <td width=100 align=center>
        <form action="cgi-bin/play.sh" method="POST"
          target=status>
          <input type="submit" value="Play">
        </form>
      </td>
      :
    </tr>
  </table>
  <hr>
  <table border="0">
    <tr>
      <td width=100 align=center>
        <form action="cgi-bin/play.sh?1" method="POST"
          target=status>
          <input type="submit" value="Eagle">
        </form>
      </td>
      :
    </tr>
  </table>
</body>
</html>
```

This uses the POST method and directs the output of whatever the `play.sh` script produces to the status window. To execute the form we define a button through the `<INPUT>` tag which displays "Play" and submits the request to execute the `play.sh` script on the server. See the excerpt from the `radio.html` file on the previous page.

The `<TD>` block between the `<TR>` tags is repeated four times to produce four rows of buttons. In between there are four blocks with the `<TD>` tags and the enclosed form. Notice that I supply an argument to the `play.sh` script by appending a question mark and a number.

You may wonder what these scripts are and where they reside on the Raspberry Pi. When the `apache2` server is installed, a directory called `/usr/lib/cgi-bin` is automatically created and you just put the scripts in there. Note that you need root permission to put files there; use `sudo`.

Let's begin with the `stop.sh` script, because it is one of the simplest. Here is the content of the file `/usr/lib/cgi-bin/stop.sh`:

```
#!/bin/bash

echo "Content-type: text/plain"
echo
echo

/usr/bin/mpc stop
echo "Radio stopped..."
```

The first line with `#!/bin/bash` tells the operating system that the contents of this file should be treated as a sequence of bash commands, where bash is a common shell (or command interpreter) for Linux. The empty lines in the file are just for structuring and to 'guide the eye'. The three lines with `echo` tell the browser what content type to expect, plus two empty lines. The setup with the forms in the HTML causes the output to be piped to the status section of our web page.

The HTML interpreter of the browser that

receives that information is instructed by the lines that there is just plain text following and therefore the browser has an idea how to format it. The line with `/usr/bin/mpc stop` executes the `mpc stop` command on the Raspberry Pi and whatever output it generates ends up in the status window. The last `echo` command writes 'Radio stopped...' to the status window.

Finally we need to make the file executable:

```
sudo chmod +x /usr/lib/cgi-bin/stop.sh
```

This changes file permissions by adding the execute bit with `chmod +x`.

The script files for 'Next', 'Previous' and the buttons in the bottom row all work in the same fashion. First there's the `#!/bin/bash` line followed by the 'Content' stuff with the three `echo` commands. Then there is just whatever `mpc` commands are required, with the output piped to the status window.

Retrieving command line arguments

The only exception is the `play.sh` command because I pass arguments to it from the browser. You can see from the `radio.html` code on the previous page that I pass the station number from the playlist in the `FORM` tag with `action="cgi-bin/play.sh?1"`.

So how do we recover the string "1" when executing the file `play.sh`? The `FORM` tag with `cgi-bin` actually makes the arguments that follow the question mark available within the executing script, in the environment variable `${QUERY_STRING}`. Here is the content of `/usr/lib/cgi-bin/play.sh`:

```
#!/bin/bash
echo "Content-type: text/plain"
echo
echo
if [ -z ${QUERY_STRING} ]; then
    /usr/bin/mpc play
else
    /usr/bin/mpc play "${QUERY_STRING}"
fi
```

The script tests if `QUERY_STRING` is empty and, depending whether it is or not, executes the `mpc play` command with or without the argument. Note that `[]` is an alternate name for the `test` command (see `man []`). The `-z` option returns `True` if the length of `QUERY_STRING` is zero.

WARNING: Please note that I do not check the `QUERY_STRING` variable for illegal characters. A malicious user could hack your system in this way. I use my Raspberry Pi behind a router on a subnet only accessible by friendly users. Do not put the system on an unprotected network without adding additional validation.

Killerqueen

So far we have the basic functionality to control the `mpd` daemon via the `mpc` program using a web interface. All that remains is to turn the Raspberry Pi off using the web interface... and that proved to be tricky. Just pulling out the power cable works, but at the risk of corrupting the file system. It's also not very graceful! I wanted a button on the web interface that would cleanly shutdown the Raspberry Pi.

My initial attempts to directly call the shutdown command via `cgi-bin` did not work, so I resorted to a trick. From the web interface I create an empty file in the `/tmp` directory called `killerqueen` (remember that Queen song?). In the background I need another program that periodically checks the existence of the `/tmp/killerqueen` file and calls shutdown if it exists.

Here is the `shutdown.sh` script that creates the `/tmp/killerqueen` file if the button on the web interface is pressed:

```
#!/bin/bash
echo "Content-type: text/plain"
echo
echo

touch /tmp/killerqueen
echo "Shutting down..."
```

The file that periodically checks its existence every two seconds is called `killerqueen.sh` which I placed in the `/usr/local/bin` directory. It contains the following:

```
#!/bin/bash
rm -f /tmp/killerqueen
while [ True ]; do
    if [ -e /tmp/killerqueen ]; then
        echo "file exists, removing"
        rm -f /tmp/killerqueen
        /sbin/shutdown -h now
    fi
    sleep 2
done
```

After initially removing any forgotten `/tmp/killerqueen` file, it enters an infinite loop and checks the existence of the file. If it exists it removes the file and calls shutdown. Then the Raspberry Pi comes to a halt and after a few seconds you can turn the power off safely.

[Ed: If you have Raspberry Pi switches from companies like Pi Supply (UK) (<http://www.pi-supply.com>) or Mausberry Circuits (USA) (<http://www.mausberrycircuits.com>) then these will automatically power off your Raspberry Pi.]

What remains is to start the `killerqueen.sh` script automatically when the Raspberry Pi is booted. This is easily done by placing the line,

```
/usr/local/bin/killerqueen.sh &
```

in the file `/etc/init.d/rc.local`. This is executed at boot time and starts the `killerqueen.sh` script as a background task.

We have come quite a way in the process of turning the Raspberry Pi into an internet radio. We covered the `mpd` and `mpc` combination plus setting up a web server. We created simple forms with framesets and interacted with the Raspberry Pi via `cgi-bin` scripts.

Please be aware that this is not the only way to achieve this functionality, but for me it was both fun and instructive. All code is available from <http://ziemann.web.cern.ch/ziemann/gadget/rasp/iradio/raspiradio.tar.gz>.

HISTORIC ARCADE GAMES

MAME - Multiple Arcade Machine Emulator



Karl Welsh

Guest Writer

Retro gaming with MAME

SKILL LEVEL : INTERMEDIATE

When arcades ruled

I remember the first video games arriving in the late 1970's. Historically, amusement arcades were located at holiday destinations and filled with electro/mechanical games and pinball machines dating back to the 1950's and 60's.

Arcades changed with the introduction of the first commercially successful 'discrete logic' or 'digital' video game, Pong (Atari Inc: 1972), and then with second generation CPU powered machines: Space Invaders (Taito/Midway: 1978), Asteroids (Atari Inc.: 1979), Galaxian (Namco/Midway: 1979), Defender (Williams Electronics: 1980), Pac-Man (Namco/Midway: 1980) and Donkey Kong (Nintendo: 1981).

A behemoth of an industry was born. Arcade games began appearing everywhere. Dedicated arcades in towns and cities, game cabinets in petrol stations, supermarkets, restaurants, pubs/bars. I used to frequent a chip shop just because it had Centipede (Atari Inc: 1980).

At its peak in 1981, arcade games generated annual revenues of over \$5 billion in the USA (\$12.79 billion in 2013 dollars). In 1983, the USA endured 'The Video Game Crash'. Financial

markets lost faith in the 'passing fad' of video games. The 'Golden Age of Video Games' was over.

Retro gaming, emulation and MAME

Peter De Vries, an American editor, novelist and satirist wrote "Nostalgia isn't what it used to be", but I disagree. 'Old school' or 'retro gaming' has a substantial following and not just because of nostalgia, but due to the restrictive/primitive nature of the hardware. Many 'retro games' are defined by their elegant simplicity and gameplay. Atari Inc. co-founder Nolan Bushnell's quote that the perfect game is "Easy to learn, difficult to master" describes the classics from the 'Golden Age of Video Games'.

An emulator is hardware or software (or both) that duplicates the functions of one computer system (the guest) in another computer system (the host) which is different from the first one. The emulated behavior closely resembles the behavior of the real system (the guest). When running an emulator such as MAME (Multiple Arcade Machine Emulator), it may seem odd that some games may be slower on the Raspberry Pi. Despite the increase in processing power, 32bit ARM vs 8bit Z80/6502 or 16bit 68000 emulation is VERY processor intensive. A 'host' system

often has to be many times more powerful than its 'guest' system.

MAME was started in 1997 by the Italian programmer Nicola Salmoria, to emulate the hardware of arcade game systems. It was originally written for MS-DOS to emulate Pac-Man, Pengo (Sega: 1982), Crazy Climber (Nichibutsu: 1980), Lady Bug (Universal/Taito: 1981) and Rally X (Namco/Midway: 1980). It now supports over 10,000 ROMs (although not all are playable). With MAME you play the original game code of classic arcade games without the highly collectable and expensive original cabinets, or inserting any coins!

ROMs and samples

ROM files will be required to run specific games. There are some ROMs available for non-commercial use at <http://mamedev.org/roms/> MAME requires the correct ROM revision for individual versions of the core program. Luckily, it will display and name the missing ROM files, so just try another ROM revision.

Some early arcade games used additional discrete logic circuits for sound (Astro Blaster (Sega: 1981), Berzerk (Stern Electronics: 1980), Donkey Kong (certain sounds e.g. The 'Jump'), Gorf (Bally Midway: 1981) etc). MAME cannot emulate these so samples are required to run correctly.

Most games up to the mid/late 1980's are fine, but some require additional emulation processing due to additional custom processors in the original cabinet.

There is a list of some great games with the game name, MAME code, revision required and whether 'samples' are needed at:

<http://www.raspberrypi.org/phpBB3/viewtopic.php?f=78&t=29427>

To run many of these MAME ROMs a license is required:

<http://www.mamedev.org/devwiki/index.php?title=FAQ:ROMs>

Compiling AdvMAME

AdvMAME can be compiled on a 256MB or 512MB Raspberry Pi. These instructions have been tested with Raspbian Wheezy. Open a LXTerminal window from the menu. Then before continuing, make sure the Raspbian installation is up to date:

```
sudo apt-get update
sudo apt-get upgrade -y
```

Download AdvMAME version 0.106.0 (advancemame-0.106.0.tar.gz) from, <http://sourceforge.net/projects/advancemame/files/advancemame/0.106.0/>

This older version will produce better results on the Raspberry Pi. Newer MAME releases offer greater accuracy in emulation, but not optimisation of performance.

Compiling AdvMAME is resource intensive. Therefore, before compilation use:

```
sudo raspi-config
```

to disable LXDE on boot. This will allow the compilation to use the physical memory on top of the ARM chip, rather than accessing swap space on the SD card. With no overclocking, it will take around six hours to compile. Some overclocking will improve the performance of the emulator. Select the highest turbo overclocking mode that is stable on your Raspberry Pi. Compilation is possible with 64MB of RAM allocated to the GPU (default setting) on a 256MB Raspberry Pi. If more memory is allocated to the GPU, it will start to use the swap space a lot more and may fail to compile. After completing the configuration, exit raspi-config and reboot.

Login using your account and password. Install the dependencies libstdl1.2-dev and gcc-4.7:

```
sudo apt-get install -y libstdl1.2-dev \
gcc-4.7
```

The gcc-4.7 compiler is needed to compile

AdvMAME with the least additional effort. (It is only possible to use the standard system compiler if several of the AdvMAME source files are modified.) To use the gcc 4.7 compiler type:

```
export CC=gcc-4.7
export GCC=g++-4.7
```

Then unpack the AdvMAME source code, configure it and compile:

```
tar xvfz advancemame-0.106.0.tar.gz
cd advancemame-0.106.0
./configure
make
```

The compilation will take four and a half to six hours, depending on your overclocking setting. When the compilation has finished type:

```
sudo make install
```

This is optional, but is useful as it negates the need to change directory or set the PATH manually.

Configuring AdvMAME

AdvMAME should be run once to setup all the correct folders and configuration files. Type:

```
advmame
```

It will give you a message telling you that it has set up the default options. To start LXDE type:

```
startx
```

There should now be a hidden folder called `.advance` in your home directory (`/home/pi` by default). If you cannot see it, right-click your mouse and tick the 'Show Hidden' box.

Now download some ROMs. As an example, the Star Fire ROM can be downloaded from <http://mamedev.org/roms/starfire/starfire.zip>

Then either use the file manager or type,

```
mv starfire.zip ~/.advance/rom/
```

to move it into place. If the selected ROM has samples, put those in the 'samples' directory. There is no need to uncompress them!

Next, edit the following file,

```
nano .advance/advmame.rc
```

and add either,

```
device_video_clock 5 - 50 / 15.62 / 50 ;
5 - 50 / 15.73 / 60
```

(on one line) for HDMI output or,

```
device_video_clock 5 - 50 / 15.73 / 60
```

for composite output. Then change the lines,

```
display_resize mixed
display_artwork_backdrop yes
display_artwork_overlay yes
```

to,

```
display_resize fractional
display_artwork_backdrop no
display_artwork_overlay no
```

Save and close `advmame.rc`. MAME can be run from LXDE, but using the console will significantly increase the performance and provide a fullscreen display. Quit LXDE.

Running MAME

Now that MAME has been fully configured, type,

```
advmame Name_of_ROM
```

where `Name_of_ROM` is the name of the ROM rather than the game title. For example:

```
advmame starfire
```

To get started press left cursor key then the right

cursor key and repeat a second time. To play other games, download them and put the ROMs into the `.advanced/rom/` directory.

Controls

Control is with the cursor keys. The fire and jump buttons are generally **Left-Ctrl**, **Space** and **Left-Alt** respectively. Joysticks and gamepads can also be configured and used. All options for control settings, video, sound, DIP switches etc. are easily modified in the options menu and can be saved for general 'All Games' or individual games 'This Game'. Other controls are:

5 - Add Coins

1 - 1 Player

2 - 2 Players

TAB - Options Menu (use Cursor Keys and Enter)

ESCape - Exit

Other configuration options

MAME settings can be infinitely customised. The defaults in `advname.rc` are perfectly acceptable for several games, but there are a few exceptions:

1. The default `'display_color'` is `'auto'`. Vector games - Asteroids, Star Wars, etc. will suffer from an incorrect application error, so DON'T change `advname.rc`! In the Options Menu (TAB) navigate to Video, Color and change `'auto'` to `'bgr16'` then `'Save for this Game'`.

2. The default `'display_mode'` is `'auto'` and `'display_magnify'` is `'1'`. Certain games suffer from an incorrect application error in Aspect Ratio (e.g. Burger Time (Data East: 1982), I-Robot (Atari Inc: 1983) and Track & Field (Konami: 1983)). Again, DON'T change `advname.rc`! In the Options Menu (TAB) navigate to Video, Magnify and change `'1'` to `'2'` then `'Save for this Game'`.

3. Consider changing `'display_resizeeffect'` from `'auto'` to `'none'`. Personally, I'm not a fan of any of these in emulations and they will be applied when changing the magnification mode as

described above. However, they can be scrolled through in the video options menu. Experiment and see if you like any of them!

4. If you are old enough to remember amusement arcades, did the SAME game seem harder in different venues? Well, it probably WAS! Inside the cabinet are toggle DIP switches that could be set to change difficulty, lives, extras, etc. These are emulated in MAME and can be configured - options (TAB), DIP Switches.

Don't like the command line?

The Advance suite of software also includes a fully integrated front end for AdvMAME, AdvMENU,

<http://sourceforge.net/projects/advancemame/files/advancemenu/>

A front end is a GUI (Graphical User Interface), which alleviates the troublesome command line typing for emulator control and execution. The front end can also be helpful when your ROM collection gets larger, since it can become hard to remember all the MAME codes (or what ROMs are in the folder!). This can be installed using the exact same method as MAME itself. Then just run the executable `advmenu`.

Older versions, better performance

Older versions of AdvMAME can often give improved results, but require changes to the scripts to compile correctly on the Raspberr Pi. I suggest downloading 0.94.0, as it requires only a few script changes. First, modify `/advance/linux/vfb.c`. Change `'MAP_SHARED ! MAP_FIXED'` to `'MAP_SHARED'`, save and close and compile as above.

In 1999, Billy Mitchell achieved the first perfect PacMan score of 3,333,360 by eating every possible dot, power pellet, fruit and enemy!

Steve Wiebe beat Billy's 1982 Donkey Kong record. Many others have tried to get higher. Hank S Chien is currently the champion with 1,138,600 points.

CHOOSE YOUR WEAPON

Adding console game controllers



Connecting an XBOX360, PS3 or Wiimote controller to a Raspberry Pi

SKILL LEVEL : INTERMEDIATE



Mark Routledge

Guest Writer

Choose your Weapon

It is possible, and lots of fun, to use a variety of today's modern console controllers for your Raspberry Pi projects. They are quite easy to install, readily available and you get quite a bit of kit for your buck! This article describes how to setup a Raspberry Pi to use a Microsoft® XBOX 360 gamepad (wired and wireless), a Sony® PS3 gamepad and Nintendo® Wiimote.

For wireless devices you will need either the XBOX gamepad wireless adapter, or for the Wiimote and PS3 gamepad you can use an expensive bluetooth dongle. See http://www.elinux.org/RPi_USB_Bluetooth_adapters for a list of known working bluetooth dongles.

I have tested all the code on a Raspberry Pi Model B, as well as on the new Model B+ board.

Before installing any of the software ensure you are using a recent version of Raspbian and have updated your system. At the command line enter:

```
sudo apt-get update
sudo apt-get upgrade
```

To test all of the hardware, an easy piece of software to use on the Raspberry Pi is `jstest-gtk` and the standard `joystick` library.

Enter the following command to install the software:

```
sudo apt-get install jstest-gtk joystick
```

This program should now show up in your desktop ready for you to test. You will find the link under Menu → Other → joystick testing and configuration tool.

Once installed it should display your hardware for example: Connecting your hardware.

A brief note about using the bluetooth adapter. I have found these can be a little temperamental at times, so I strongly recommend connecting your dongle directly to the Raspberry Pi and connect any other hardware via a powered USB hub, e.g. the excellent Raspberry Pi Hub! The bluetooth dongle will work from a powered hub on a low level, but the bluetooth stack may not be able to see it.

Setting up the XBOX gamepad

First open up LXTerminal and install the required driver for the XBOX 360 gamepad. The same driver is used for both the wired gamepad and wireless gamepad, using the adapter. Enter:

```
sudo apt-get install xboxdrv
```

It is possible to now use the XBOX gamepad with a variety of Linux games by using:

```
sudo xboxdrv --silent
```

However, this does not really give you much control over what each axis / button does. You can use the joystick testing and configuration tool mentioned earlier but it can be difficult to get setup. Luckily it is possible to configure the XBOX gamepad in a variety of ways. Each configuration requires a setup (text) file which you provide when launching the gamepad and driver. Through this you can turn one of the analogue sticks into a mouse and the buttons into keypresses etc. This will make it usable with programs like Minecraft, Doom, Quake3 plus all known emulators. The possibilities are endless, and exciting.

Let us make a directory to store these setup files, which contain the button mappings. Enter:

```
cd ~
mkdir XBOX
cd XBOX
```

Create a configuration text file called `basic_config`. You can use any editor, but `nano` is quick and simple. Enter:

```
nano basic_config
```

Now enter the following mappings:

```
#-----
# This file is the Basic Definition of
# the controller, allowing a deadzone.
# It will run silently.
#-----
# Setup the DPad as buttons and triggers.
#
[xboxdrv]
silent=true
deadzone=6000
dpad-as-button=true
trigger-as-button=true
#
#-----
# Map the right analog stick as absolute
# values (x2 and y2) and the left analog
# stick as mouse relative (x1 and y1).
#
[ui-axismap]
```

```
x2=ABS_X
y2=ABS_Y
x1=REL_X:10
y1=REL_Y:-10
#
# -----
# Map the four coloured buttons a, b, x
# and y and set each one as a different
# key, or equivalent joystick button.
# In this case Left Shift, joystick
# buttons C and A and the key C.
# Map the triggers and bumpers in the
# same way; lt, rt, lb and rb.
# Map the DPad du, dl, dd, dr as WASD.
# Map the Back, Start and Guide (XBOX)
# buttons to Home, Escape and Enter.
#
[ui-buttonmap]
a=KEY_LEFTSHIFT
b=BTN_C
x=BTN_A
y=KEY_C
#
lb=KEY_LEFT
rb=KEY_RIGHT
lt=KEY_Z
rt=KEY_SPACE
#
dl=KEY_A
dr=KEY_D
du=KEY_W
dd=KEY_S
#
guide=KEY_HOME
back=KEY_ESC
start=KEY_ENTER
#----- EOF -----
```

Save and close the configuration file and exit from `nano` by pressing the `<Ctrl>+<X>` keys together, followed by the `<Y>` key then `<Enter>`.

Description of the XBOX config file

This file is the basic definition of the controller, allowing a deadzone. It will run silently, meaning it will not output additional information to the terminal.

The file sets up the DPad as buttons and triggers. The next few sections are used to map the right analogue stick as absolute values on the `x2` and `y2` axes and the left analogue stick as mouse relative values on the `x1` and `y1` axes.

It maps the four coloured buttons a, b, x and y and sets each one as a different key, or equivalent joystick button, in this case Left Shift, joystick buttons C and A, and the C key.

It also maps the triggers and bumpers (lt, rt, lb, rb) in the same way.

Finally it maps the DPad (du, dl, dd, dr) as the classic W, A, S, D keyboard setup. It also sets the Back, Start and Guide (XBOX) buttons to the Home, Escape and Enter keys respectively.

You can now physically plug in your XBOX gamepad or adapter if you have not already done so. I recommend connecting the gamepad or adapter for the XBOX 360 to a powered hub.

Do a quick list of USB devices to check that the gamepad or adapter has been detected. Enter:

```
lsusb
```

You should see an entry for the XBOX gamepad or adapter similar to,

```
Bus 001 Device 009: ID 045e:028e Microsoft Corp. Xbox 360 Controller
```

or,

```
Bus 001 Device 008: ID 045e:0719 Microsoft Corp. Xbox 360 Wireless Adapter
```

Finally call the basic configuration mapping using the `--config` switch with your configuration file:

```
sudo xboxdrv --config ~/XBOX/basic_config
```

You can run this command in the background by adding an `&` at the end of the command.

At this point you can either use the command,

```
sudo jstest /dev/input/js0
```

to test the gamepad from the command line or,

```
startx
```

and select the joystick testing and configuration tool.

For the wired gamepad you should be connected and up and running.

If you are using the wireless gamepad you will have to sync it to the adapter. This is done by pushing the Sync button on the adapter then pushing the Sync button on the gamepad.

Note: Even though the gamepad is connected, the XBOX pad quadrant light will continue to flash! There is no quick or easy way to turn off the pad once you have finished using it, other than temporarily removing the battery pack for a few seconds.

If you are keen to test your new setup in Python follow the excellent tutorial provided by Rhishi Despanda in The MagPi Issue 26, pages 12-13.

Setting up the PS3 gamepad

If you have the PS3 gamepad wired into a USB hub with the charging cable, the Raspberry Pi should detect the gamepad and work almost immediately. You may have to press the "PS" button to start though.

Alternatively you can use a bluetooth dongle. Again, connect the bluetooth dongle directly into one of the Raspberry Pi's USB ports, not via the USB hub. The following drivers and settings will only work with genuine PS3 gamepads. Cheap imports simply do not seem to work. Save your money and buy an official second hand PS3 gamepad!

Wired PS3 gamepad

To test a wired PS3 gamepad list the USB devices with the command:

```
lsusb
```

You should see something similar to:

```
Bus 001 Device 008: ID 054c:0268 Sony Corp. Batoh Device / PlayStation 3 Controller
```

Either test from the console with the command,

```
sudo jstest /dev/input/js0
```

or,

```
startx
```

and use the joystick testing and configuration tool.

Wireless PS3 gamepad

Install the required libraries to start bluetooth. This may seem like a lot, but it will save time and bother later. Enter:

```
sudo apt-get install bluez-utils
sudo apt-get install bluez-compat
sudo apt-get install bluez-hcidump
sudo apt-get install checkinstall
sudo apt-get install libusb-dev
sudo apt-get install libbluetooth-dev
```

Next download the drivers for pairing the bluetooth dongle to the PS3 gamepad. Enter:

```
sudo wget http://www.pabr.org/sixlinux/sixpair.c
gcc -o sixpair sixpair.c -lusb
```

Note: If this second command fails ensure that you have installed libusb-dev properly.

After this you should have a executable file called sixpair.

Check that your bluetooth dongle is detected by listing the USB devices with the command:

```
lsusb
```

You should see your adapter listed, for example:

```
Bus 001 Device 004: ID 0a12:0001 Cambridge Silicon Radio, Ltd Bluetooth Dongle (HCI mode)
```

Now connect your PS3 gamepad via a USB cable to the Raspberry Pi and use sudo to execute the sixpair file:

```
sudo ./sixpair
```

If you receive an error about hcitool then again make sure you installed all the above packages.

The program should list two MAC addresses, but they may not be the same. For example:

```
Current Bluetooth master:
00:15:83:0c:bf:eb
```

```
Setting master bd_addr to
00:1b:dc:0f:ed:b5
```

Run the command again and you should see:

```
Current Bluetooth master:
00:1b:dc:0f:ed:b5
```

```
Setting master bd_addr to
00:1b:dc:0f:ed:b5
```

You have successfully paired your controller with your bluetooth dongle. We now need to install the Sixaxis drivers required for the PS3 gamepad to work like a joystick.

Install the Sixaxis joystick manager

We will download the latest archive and compile it. To get the driver tarball (compressed file) enter the following command all on one line:

```
sudo wget http://sourceforge.net/projects/qtsixa/files/QtSixA%201.5.1/QtSixA-1.5.1-src.tar.gz
```

Expand the driver with the command:

```
tar xfvz QtSixA-1.5.1-src.tar.gz
```

Navigate into the driver directory:

```
cd QtSixA-1.5.1/sixad
```

Make the required driver for the Raspbian build:

```
sudo make
```

Make a directory to store different profiles for the PS3 gamepad with the command:

```
sudo mkdir -p ~/var/lib/sixad/profiles
```

Finally, install the required driver that you have just made. Enter:

```
sudo make install
sudo checkinstall
```

The last command automatically creates a package for you, so you can easily uninstall it later if you no longer need it or want to use a different system. To uninstall, enter the command:

```
sudo dpkg -r sixad
```

Now to test it, launch temporary a sixad daemon.

```
sudo sixad --start
```

If the gamepad is still plugged in, unplug it and then press the "PS" button on the Dualshock gamepad. If you feel a vibration then it works. Congratulations!

You may not feel a vibration, but it should display some sort of connection on the screen. For example, you should see something like:

```
sixad-bin[6860]: Connected Sony Computer
Entertainment Wireless Controller
(04:76:6E:F1:74:3E)
```



Note: On both the PS3 gamepads that I have tested, NEITHER vibrated! Although both are correctly detected using the joystick testing and configuration tool, one of the gamepads shows no signs of connection (no red flashing LEDs) while the other continuously flashes! Both are official "Dualshock 3" Sixaxis gamepads, but both are also second-hand and I cannot vouch for the working vibration as I do not have a PS3!

To make the sixad daemon run automatically every time you start the Raspberry Pi, enter the following command:

```
sudo update-rc.d sixad defaults
```

To end the connection with your gamepad once you are finished using it, run the following two commands:

```
sudo sixad -stop
sudo service bluetooth stop
```

This will free up your PS3 gamepad and it should return to sleep!

Nintendo Wiimote

You will need to use a bluetooth dongle. It is recommend to always plug the bluetooth dongle directly into one of the USB ports on the Raspberry Pi, not the USB hub!

Ensure that the bluetooth driver is correctly installed with the command:

```
sudo apt-get install bluetooth
```

To check the status of the bluetooth driver, enter the command:

```
sudo service bluetooth status
```

You should see something similar to:

```
[ ok ] bluetooth is running.
```

If you do not see this then enter the command:

```
sudo service bluetooth start
```

Now install the CWiiD, WMInput and WMGui packages. These are required to use a Wiimote:

```
sudo apt-get install python-cwiid
sudo apt-get install wminput wmgui
```

Run the hcitool to check the bluetooth adapter:

```
sudo hcitool dev
```

Start the Wiimote in detection mode by either

pressing the small red sync button or holding buttons 1 and 2 on the Wiimote until the lights flash. Now run the `hcitool scan` command to locate your bluetooth Wiimote. Enter:

```
sudo hcitool scan
```

After a short period of time it should list your Wiimote as a Nintendo RVL. For example, you should see something like:

```
Scanning ...
00:1D:BC:FB:79:F0      Nintendo RVL-CNT-01
```

Write down whatever was displayed as the MAC address for your Wiimote. We will use this later.

Universal input needs to be setup so it can be used by users other than 'root' users. We will edit the Wiimote rules using nano. Enter:

```
sudo nano /etc/udev/rules.d/wiimote.rules
```

Add the following line to the bottom of the file:

```
KERNEL=="uinput", MODE:=="0666"
```

Save and close the file by pressing <Ctrl>+<X> together, then press <Y> and <Enter>.

You need to reboot your Raspberry Pi for the changes to take effect. Enter the command:

```
sudo reboot
```

Wiimote configuration file

We have setup and detected all the hardware. We must now create a custom Wiimote configuration file using nano that maps the inputs from the Wiimote to buttons. Enter:

```
nano /home/pi/mywminput
```

Now enter the following mappings:

```
# -----
# Setup for standard Wiimote
Wiimote.A = BTN_A
# The trigger is button B.
Wiimote.B = BTN_B
# Setup the DPad
Wiimote.Dpad.X = -ABS_Y
```

```
Wiimote.Dpad.Y = ABS_X
# Setup the remaining buttons
Wiimote.Minus = BTN_SELECT
Wiimote.Plus = BTN_START
Wiimote.Home = BTN_MODE
Wiimote.1 = BTN_X
Wiimote.2 = BTN_Y
#----- EOF -----
```

Save and close the file by pressing <Ctrl>+<X> together, then press <Y> and <Enter>.

Finally it is time to test the Wiimote. Enter the following command on one line:

```
sudo wminput -d -c /home/pi/mywminput
<Wiimote address> &
```

Replace the <Wiimote address> with the MAC address we wrote down earlier.

The & at the end just means that this process will keep running in the background while you do other things... like play games!

Finally, test the Wiimote with the command:

```
sudo jstest /dev/input/js0
```

Game on!

Now that you have successfully got your controller working why not take it for a spin using one of the games previously mentioned, setup an excellent emulator like Picodrive or try some Linux games that can be easily installed. Try any of the following games for some light relief:

```
sudo apt-get install abuse blobwars
sudo apt-get install frozen-bubble geki3
sudo apt-get install hex-a-hop ltris
sudo apt-get install supertux triplane
sudo apt-get install xblast-tnt xracer
sudo apt-get install xscavenger
```

I intend to write a follow-up article where I will give examples of how to use each of these different devices from within Python and Linux.

For all this and **much more** please visit my Raspberry Pi documentation project at <http://goo.gl/EEQ5J> [Ed: I have added this page to my favourites!]

Fly your Cobra MkIII trading and combat craft in this classic game

SKILL LEVEL : BEGINNER



David Honess

Guest Writer

Unless you're around my age, or older, two things are probably true about you. One is that you have never played Elite and the other is that the logo below probably looks like it's for a garden centre! Fear not, I am going to let you in on all these strongly guarded secrets. After reading this you will be able to go up to older gamers and watch their jaws hit the floor when you hold your own in a conversation about a seminal game from the 1980s.



Back in 1987 Acorn Computers released the successor to the BBC Micro. It was called the Archimedes and it was tremendously popular. It had a new kind of processor called a RISC chip (Reduced Instruction Set Computer). Acorn Computers evolved over the years into what is now called ARM and you have an ARM processor in your Raspberry Pi. So you could say that the Raspberry Pi is the great-great-grandchild of the Archimedes? Up to you, but that mantle probably belongs to Acorn's earlier BBC Microcomputer.

Acorn made an operating system for their RISC chips called RISC OS which was a hugely popular, much loved, operating system. It is still being developed and in November 2012 RISC OS was released for the Raspberry Pi as an SD card image that you can download. If you're a fan of drag and drop OSES you will get on fine with it.



Elite was a seminal computer game that changed the entire landscape of gaming. Back in the early 1980s computer games were all about getting the highest score before your lives ran out. Elite was an open ended game that had no score, no levels and no bosses – just one enormous galaxy within which you could do whatever you wanted. This is what people call a “sandbox” game.

Elite originally came out in 1984 on the BBC Micro (above) and had wireframe graphics. By the time the Archimedes version was released in 1991 they had improved the graphics a fair bit. The Archimedes version of Elite is widely regarded as the best version of the original game, so in the instructions that follow I am going to explain firstly how to get the game running and secondly how to play it.

Our goal here is to run the Archimedes version of Elite on your Raspberry Pi. Unfortunately Arc Elite will not run natively on the Raspberry Pi because the Archimedes processor is 26 bit whereas the Pi processor is 32 bit. So we need to use an emulator. This is a program that will

basically fool the game into thinking it's running on a real Archimedes computer and thus will run normally. We will use ArcEm which gives you a fully functional Archimedes desktop environment to work in (within which we will run the game).

The first thing we need to do though is install and boot RISC OS. This was covered in Issue 9 of The MagPi (see <http://goo.gl/XsCqoL>). If you don't have a UK keyboard you'll want to change the keyboard setting. Double-click on the !Configure icon then click on the Keyboard icon. Change the keyboard to your locale.

A quick note about the RISC OS mouse. This had three buttons. Clicking the mouse wheel on your modern mouse will do the job of the middle mouse button (button 2). It's actually the middle click that gives you context menus similar to those that you have in Windows. We'll be using those later.

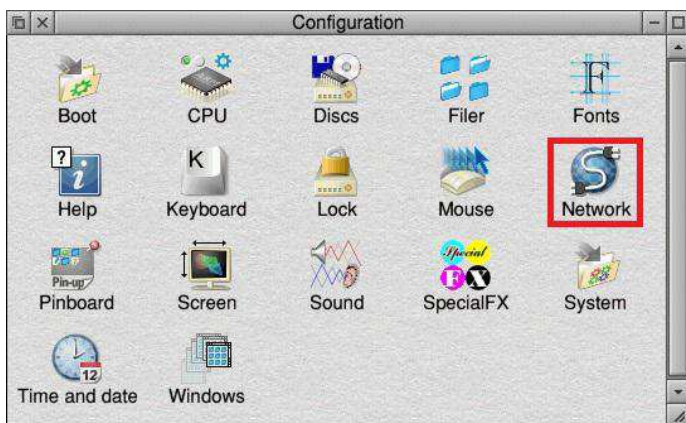

To download the necessary Archimedes emulator and files for Elite we will need to have an internet connection. Alternatively you can copy the files over from a USB memory stick. To configure network access, if it is not already working by default, double-left click on the desktop icon named !Configure and then double click the Network icon on the right. From here enable the TCP/IP protocol suite in Internet configuration:

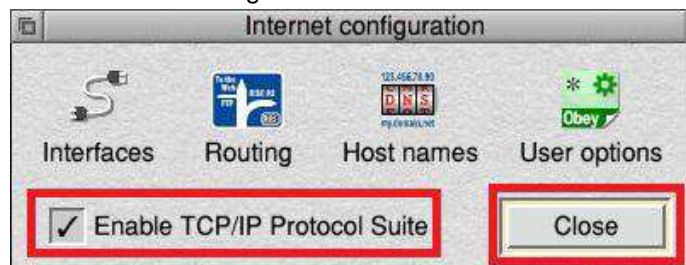

RISC OS behaves differently to Windows and Linux. When you double-click an application to start it (eg !NetSurf) it might seem that nothing has happened. But look in the bottom right-hand corner of the Icon Bar. Your application is running... just click on its icon to open it.

To obtain ArcEm load the !NetSurf browser, navigate to <http://arcem.sourceforge.net> and download the latest version via the "get it here" link. If you have trouble finding

it type the following into the address bar on !NetSurf: <http://sourceforge.net/projects/arcem/files/latest/download?source=files>. Make sure you download the RISC OS version and not the default Windows version!

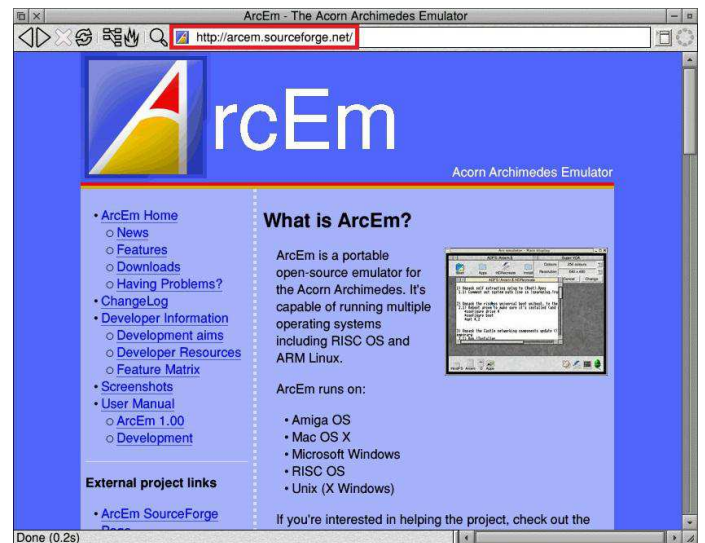

Note that !NetSurf may display an error saying Bad type. This is because it does not recognise the automatic download that the Sourceforge site tries to launch. Click on the direct link in Sourceforge and the download will start.

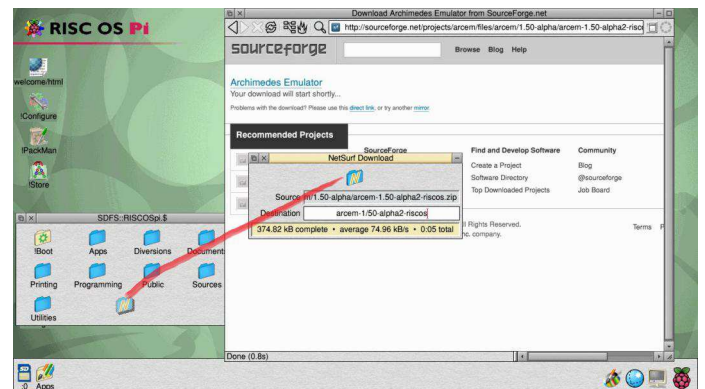

Tell RISC OS where you want the downloaded file to go by first double clicking the SD card icon in the bottom left, then use button 1 to drag the icon within the NetSurf Download box into the SD card window (as above).

The zig-zag on the downloaded file is because it is a Zip file (it has other files compressed inside it). With some of the download mirrors the file type is not set to Zip. You can tell when this happens because the download icon will be green with the word "Data" and not a folder with a zig-zag. To fix this move your mouse over the icon and click the middle mouse button (scroll wheel), choose "File 'arcem-1/50-riscos'" -> Set type -> then change Data to Zip (ie type Zip).

The next thing we need to do is create a new folder to unzip the emulator into. Middle click (mouse wheel) somewhere in the SD card folder and a context menu will appear.

Choose New Directory > (move the mouse over the arrow), type ArcEm into the box and double click the new ArcEm folder. An empty window will display, Double click on the Zip file and you will see two folders. Open the "Apps" folder then the "Misc" folder. You will see 3 files (!ArcEm, COPYING and hostfs). Select and drag these files into the ArcEm folder.

Before we can run the emulator we need to give it a ROM file. This is an image of the original Archimedes operating system that the emulator will boot up into. We will use RISC OS v3.10. Open !NetSurf, navigate to <http://home.tiscali.nl/~jandboer/> and download the file called ArchiEmu (5M). We now need to get the ROM file out of the zip file. Double click the archi.zip file. You will see an icon called !Boot. It's actually a program, so don't double click it - double clicking on programs runs them. Hold down the Shift key and then double click it. You'll see another window with a Resources folder. Double click the Resources folder to open it. Now hold down the Shift key and double click on !ArchiEmu. You'll see another window with an OS folder. Double click the OS folder and now you'll see the file we want. It's named ro310. Drag it into the SD card window.

We now need to change a few properties on this file so that our ArcEm program will recognise it. These can each be done by middle clicking (mouse wheel) on the ro310 file. First we must remove its access protection (File 'ro310' > Access > Unprotected), then set its file type to Data (File 'ro310' > Set type > type Data) and finally rename the file to ROM (File 'ro310' > Rename > type ROM in capitals).

Open the ArcEm folder again. Hold down the Shift key and double click the !ArcEm icon. That will show the ArcEm program files. Drag the ROM file here.

We can now run the emulator to see if it works. Double click the !ArcEm icon. The screen will go black for a moment and you will see the actual boot up sequence of the original Archimedes computer.



If the screen is a little stretched you can fix this by pressing F12 and a small command prompt will appear at the bottom of the screen. Type wimpmode 28 and press Enter twice. Now you should have a 4:3 screen ratio (640x480 at 256 colours).

You can make screen mode 28 permanent by setting it as

the default screen mode in the Archimedes configuration. First double click on the Apps icon in the bottom left and then double click !Configure. It will appear in the task area in the bottom right. Click on it and then click the screen icon. Set the Default screen mode setting to 28. You can click where the current number is and edit it as text.

In the bottom left corner of the screen you'll see an icon named HostFS. This corresponds to the hostfs folder back in Raspberry Pi land that you may have noticed before (see below). Anything you put in here can then be accessed by the emulated Archimedes. Guess what we need to put in here? The game!

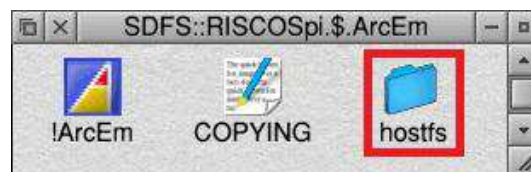

The emulator does not shut down very gracefully, if you middle click on the Acorn icon (bottom right) you can choose Exit from the context menu. But this just causes a hang. Until this bug is fixed you need to power cycle your Pi (turn it off for a second, then back on again). It is perfectly safe to do this.

When the Pi has rebooted open !NetSurf again and navigate to <http://www.iancgbell.clara.net/elite/arc/> The file we want is marked **Click here to download Arc Elite (419 Kbytes)**.

Drag the file into the SD card window, just like the other downloads we did, and you'll now see a file called **b5052410**. We need to change the type of this file to Zip so that we can extract the game. To do this middle click (mouse wheel) on the file and select File 'b5052410' > Set type and enter Zip.

Now we can extract the zip file into ArcEm's hostfs folder. Open the ArcEm folder again, then the hostfs folder. Double click the b5052410 zip file. You will now see the game files. Position the hostfs and b5052410 windows so that they are side by side (drag the title bar). Drag a box around all the game files and finally drag them all into the hostfs folder. You will then see a copying dialog box as shown below.

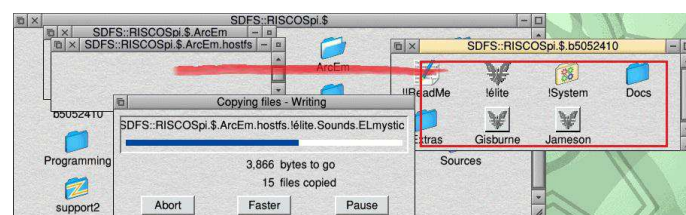

Run !ArcEm again and this time the game will be available. When you get to the Archimedes desktop, double click the HostFS icon and you should now see the game. Double click the icon named !elite to start the game. You will be

asked if you have a high resolution monitor, press Y. The game will appear in the bottom right corner as an icon and probably named Jameson (the default commander name). Click this and you can then start playing!

When in the game you can press F12 to go back to the desktop. If you middle click (mouse wheel) the Jameson task icon you can get access to an Elite Preferences menu where you can configure the game settings (see below). I would suggest turning down mouse sensitivity to 1, or disabling the mouse altogether and playing the game with keys. That way the mouse works when you're in the menus and you use keys for flight. There is also a save game menu you can access from here.

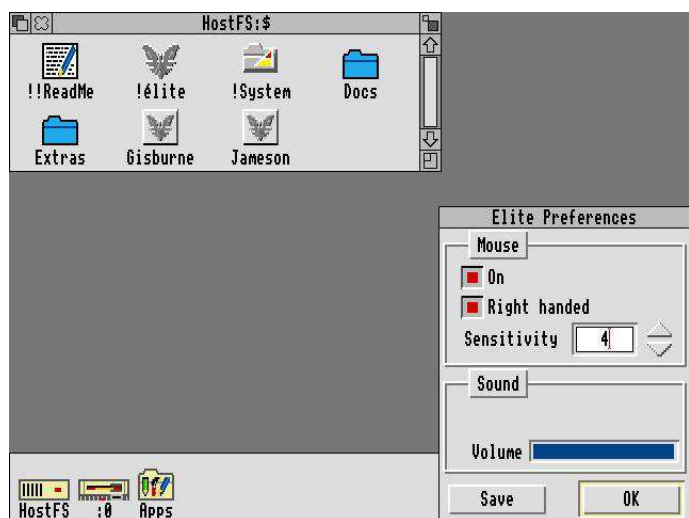

In the Docs folder (above) there are some documents that come with the game that you can read. The basic idea in Elite is that you start off with a really poor space ship and by trading goods, narcotics, radioactive material etc you can earn money to buy better stuff for your ship, or buy a whole new ship.



If you want to fly using the mouse, this is a skill in itself. I recommend you press the Caps Lock key to turn on an auto centering feature which makes it 100% easier. Mouse button 1 is the fire button while buttons 2 and 3 are for speed up and slow down respectively.

On the keyboard the flight keys are S, X for pitch and <, > for roll, ? and Space bar for speed up and slow down and A is fire. To jump to another star system, press F6, choose the planet you want and then press H (for hyperspace). This will give you a 10 second count down to your jump. Manually docking with space stations is especially hard. To help, here is a video of someone doing this on the BBC version of Elite: <http://youtu.be/X0czVxiEqNM>

The basic idea is that you need to find the space station, get yourself lined up with its letter box shaped entrance, then fly into it as straight as you can. If you get it wrong you're dead (the game is actually that brutal). Here is how I usually do it. After you do a hyperspace jump you'll see a planet somewhere near you. Head towards it and press J to jump. If another ship gets near you a message saying MASS LOCKED will appear - you can't fire your jump drive when something else is near you. If it's a pirate you'll need to fight. Often getting them to crash into your shields is enough to kill them. Keep heading towards the planet. It should get bigger as your approach.

If you look at the game screen shot to the left, you'll notice there is a square box with a green cross hair, just below the E in MISSILE. This is used to help you locate the space station. It will show as a white dot if the station is in front of you and a red dot if behind. Try and get the white dot in the centre of the cross hair. That then means you're flying directly towards the space station. When you get near it, start slowing down and get ready to do what you saw in the video above. Fly roughly near the station, slow right down, then point towards the centre of the planet, speed up again and fly towards it for a few seconds. Slow down again, now point yourself back to the station and you should now see the entrance is pointing towards you (the entrance always points at the centre of the planet). Speed up again to about 1/3 and head in for docking. You might need to repeat this manoeuvre a few times to get yourself properly lined up. When you're happy with your alignment, you can try and match your rotation with the rotation of the space station. What I tend to do is get quite close, wait for the letter box to be horizontal and then floor it through!

To really get into the Elite world, you can read "Elite: The Dark Wheel", a short novella by Robert Holdstock. It's available at www.iangcbell.clara.net/elite/dkwheel.htm.

Watch out for the Vipers, Commander Jameson!

The MagPi wishes to thank:

Ian Bell (www.iangcbell.clara.net/elite),
David Braben (www.frontier.co.uk),
3QD Developments Ltd (www.riscos.com),
Castle Technology Ltd,
and RISC OS Open Ltd (www.riscosopen.org)
for their support with this article.

```
class Factorial:
    def __init__(self,n):
        self.n = n
        self.fact = 0
        self.count = 0
    def next(self):
        if self.count > self.n:
            raise StopIteration
        self.fact *= self.count
        if self.fact < 1:
            self.fact = 1
        self.count += 1
        return self.fact
```

TEXT ADVENTURE

A Tim Hartnell game in Python



Martin Hodgson

Guest Writer

Stronghold of the Dwarven Lords

SKILL LEVEL : BEGINNER

Introduction

In the early 1980s, as early home computers boomed in popularity, a little programming knowledge was essential. My first computer was a Sinclair ZX81 with 1KB of memory. I used to dream of being able to afford a 16KB RAM expansion! To make the ZX81 do anything at all, you had to know a few BASIC commands. Thankfully, the computer's manual included a good introduction to BASIC programming. For those interested in more advanced programming, magazines like ZX Computing and Creative Computing included listings of BASIC programs. These were mostly games that could be typed in, played, saved and hacked to your hearts content. It was great fun and a fantastic way to learn how to program.

During the early '80s, the late Tim Hartnell was a prolific author of BASIC games and published many articles and over 30 books. Second-hand copies of his books are still readily available online and a few PDFs can be found on vintage computer fan websites.

Stronghold of the Dwarven Lords

Stronghold of The Dwarven Lords is a simple adventure game, from the 1984 book "Tim Hartnell's Giant Book of Computer Games". In my Python translation I try to stick as closely as possible to Tim's original BASIC version. The Python that follows is written in Python 3. Start by opening the Python IDLE3 shell., then press Ctrl+N to open a new window. I suggest typing the program in manually, just like we would have done 30 years ago. Try to work out how it works as you go along.

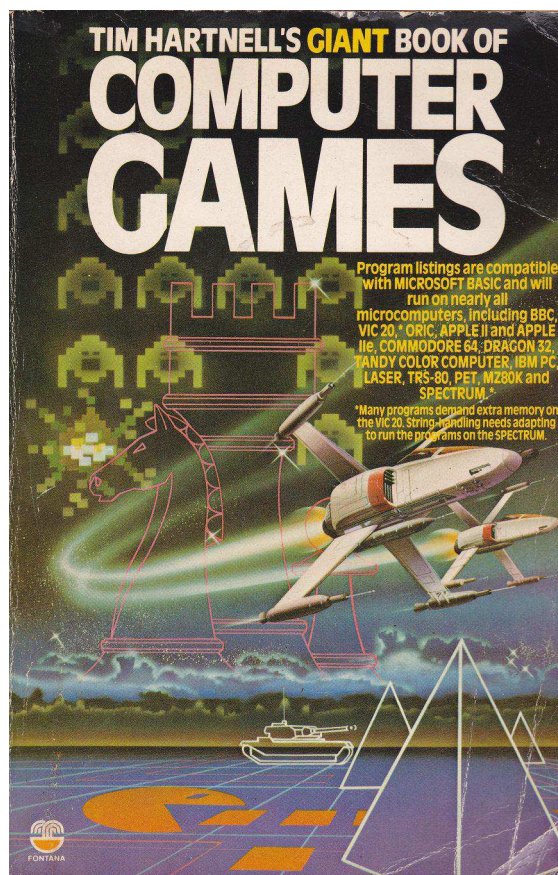

```

# STRONGHOLD OF THE DWARVEN LORDS v2.1
# Martin Hodgson - November 2013
# Translated from Tim Hartnell's original BASIC version...
# ...with a couple of updates. Now you can't walk through walls!

import random

# VARIABLES, LISTS
data1 = [2,2,2,3,2,4,2,5,2,6,2,7]
data2 = [3,7,4,7,5,7,5,6,5,5,5,4,5,3,6,3]
data3 = [7,3,7,4,7,5,7,6,7,7,7,8,7,9,9,8]
data4 = [9,9,10,8,10,7,10,6,10,5,10,4,8,8]
data5 = [10,3,11,3,12,3,13,3,14,3,14,2,7,10]
data6 = [6,10,5,10,4,10,3,10,2,10,2,11,2,12]
data7 = [2,13,2,14,6,11,6,12,6,13,6,14,7,12]
data8 = [14,12,8,12,8,14,9,12,9,13,9,14,10,12]
data9 = [11,9,11,10,11,11,11,11,12,12,9,13,9,13,10]
data10 = [13,11,13,12,13,13,13,14,14,14]
data = data1 + data2 + data3 + data4 + data5 + data6 + data7 + data8 + data9 + data10

# FUNCTIONS
def new_game(): # GOSUB 640 in original BASIC version
    global a, b, z, y, x, s, m, a, e, d
    print ("=====\n")
    input ("STRONGHOLD OF THE DWARVEN LORDS\nNew Game - Press Enter...")
    # Item zero and the zero at the beginning of each sub-list will be ignored...
    # ... as the BASIC program uses indices 1-15
    a = [[0], [0], [0], [0], [0], [0], [0], [0], [0], [0], [0], [0], [0], [0], [0]]
    b = random.randint(1, 3)
    z, y = 14, 14
    if b == 2:
        y = 2
    if b == 3:
        z = 2
    x, s = 1, 2
    for b in (range(1, 16)):
        for c in (range(1, 16)):
            a[b].append(x)
            if random.randint(1, 10) > 8:
                a[b][c] = s
            if c<2 or c>14 or b<2 or b>14:
                a[b][c] = x
    d, e = 2, 2
    for f in (range(0, 136, 2)):
        b = data[f]
        c = data[f+1]
        a[b][c] = s
    a[z][y] = s # Makes sure the gold isn't in a wall
    m = -15
    return

def show_map(): # GOSUB 480 'help' in original BASIC version
    global b, m
    print ("\n=====\n")
    print ("North")
    b = 15
    while b > 0:
        strng = ""
        for c in (range(1, 16)):
            if a[b][c] == x:
                strng += ("##")
            elif b == d and c == e:
                strng += "*"
            elif a[b][c] == s:
                strng += " "
        print (strng)

```

```

    b -= 1
    print ("South")
    m += 15
    a[d][e] = s
    # Here I've omitted two lines from the BASIC version:
    # 600 FOR J = 1 TO 2000:NEXT J - Makes the program pause.
    # 610 CLS - Clear screen. Not possible in Python Shell?

def move(): # Lines 50 to 410 - Main game script from BASIC version
    global m, d, e
    m += 1
    print ("\n===== \n")
    print ("STEP NUMBER", m)
    if a[d+1][e] == s:
        print ("NORTH: OPEN")
    elif a[d+1][e] == x:
        print ("NORTH: WALL")
    if a[d-1][e] == s:
        print ("SOUTH: OPEN")
    elif a[d-1][e] == x:
        print ("SOUTH: WALL")
    if a[d][e+1] == s:
        print ("EAST: OPEN")
    elif a[d][e+1] == x:
        print ("EAST: WALL")
    if a[d][e-1] == s:
        print ("WEST: OPEN")
    elif a[d][e-1] == x:
        print ("WEST: WALL")
    print ("THE DWARVEN SOURCE BEAM READS:", (100 * abs(z-d) + 10 * abs(y-e)))
    print ("Which direction do you want to move...")
    a_string = input ("N - north, S - south, E - east, W - west, H - help ? ")
    a_string = a_string.upper() # Convert lowercase to upper case
    if a_string == "H":
        show_map()
    elif a_string == "N":
        d += 1
    elif a_string == "S":
        d -= 1
    elif a_string == "E":
        e += 1
    elif a_string == "W":
        e -= 1
    else:
        print ("\nPardon? I don't understand...") # Inform the player that the command isn't recognised
    if z == d and y == e:
        win()
    if a[d][e] == x: # In the original you could walk through walls... Now you can't!
        print ("\nOuch! You just walked into a wall...")
        if a_string == "N":
            d -= 1
        elif a_string == "S":
            d += 1
        elif a_string == "E":
            e -= 1
        elif a_string == "W":
            e += 1

def win():
    print ("\nYou found the Dwarven riches in just", m, "steps!\n")
    show_map()
    # This feature has been added - The original version would just END.
    new_game()
    show_map()

```

```
# MAIN PROGRAM
new_game()
show_map()
while(1):
    move()
```

How to play

First, read the following introduction by Tim Hartnell, whose prose revealed his great enthusiasm for game programming...

STRONGHOLD OF THE DWARVEN LORDS

Deep beneath the earth you go, far into the Dwarven Heartland. Danger is on every side as you descend, but your greed draws you on. Searching through the dusty stacks of uncatalogued manuscripts in room 546B of the British Museum, you came across a faded and almost illegible map to a Dwarven hoard of gold. Since that day you have been obsessed with the idea of finding it.

As you go down into the labyrinth you realise that the Dwarven Lords, who secreted the gold here 7389 years ago, have long since become extinct. So the main danger you face is from the layout of the cavern system itself, rather than from Guards of the Stronghold.

In STRONGHOLD OF THE DWARVEN LORDS you are in a cavern which holds the gold. Each time you play this game, the gold can be in one of three places. The only information you get as to your progress is information provided by the Dwarven Source Beam which you found as you made your way into the cave system. This gives you feedback after each move as to the location of the gold, but you need to learn how to interpret the information it gives you before you'll be able to make much use of it.

When the game starts you are shown a map of the cavern system with your position indicated as an asterisk *. Your aim is to find the hidden gold with the minimum number of steps. Each turn you are given a brief description of your surroundings and must choose the direction to take next. Once the map scrolls off the screen you are only allowed to look at it again by choosing H for help. However, each time you ask for help you are penalised 15 steps.

How the program works

For those with a basic understanding of Python, you will see that the main parts of the program are structured as follows:

- At the beginning there are a few data lists of numbers that are combined together to make one big list.
- There are the functions: `new_game()`, `show_map()`, `move()` and `win()`.
- Then finally there is the main program, which calls the functions in order to initiate the first game.

Tim's original variable names are not very descriptive. For me this added to the fun of working out how the program works. My code only uses basic Python constructs. The `new_game()` function is probably the most complicated part of the program; it creates a list of 15 x 15-item 'sub-lists' that represents the map. This is done by first creating a grid that is designated as 'all wall', but with a few random spaces. Then more spaces are added according to the data list. Hopefully, this will become clearer as you type in the program and play the game.

Have fun finding Tim's gold!

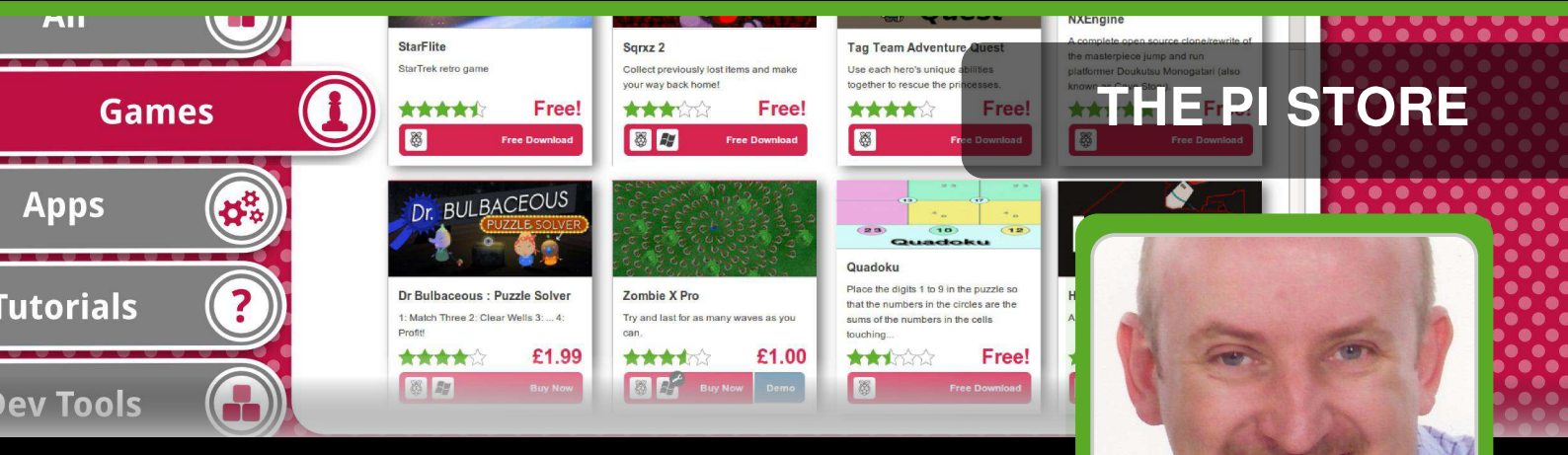

A look at the diverse range of applications in the Pi Store



SKILL LEVEL : BEGINNER

Two years ago the Pi Store was launched with just 24 titles. Today there are over 120 titles and the vast majority are free. The MagPi takes a look at some of the diverse content in the Pi Store, especially the non-free content, to help you determine what is worthy of your time and money.

Digital downloads

Apple was one of the first companies to encourage the mass adoption of digital downloads with its iTunes store for music and movies. This was later followed with the App store, the iBooks store and finally iTunes U for students. The App store was the only way you could get applications for Apple mobile devices and later it was extended to Apple's MacBook and iMac computers.

Amazon pioneered the digital download of books and today most major bookstores have digital download affiliations. Of course the instant gratification advantages of digital downloads were not lost on game console manufacturers with Microsoft, Sony and Nintendo all introducing digital download stores for their respective game consoles. Digital app stores are less prevalent for Windows based PCs with notable exceptions being game centric Steam and Origin.

Introducing the Pi Store

Ultimately all of the previously mentioned digital download stores have a commercial interest for the host company. But this was not the case for the Raspberry Pi Foundation when they launched the Pi Store. Instead of thinking how much money could be made, they saw all the advantages of having an app store dedicated to the Raspberry Pi:

- a place where developers of all ages can share their creations with the Raspberry Pi community.
- a place where complete beginners can install and remove great Raspberry Pi titles without having to go near a command line.
- a place where every Raspberry Pi user can discover new content for their computer.

Unfortunately some did not see this and criticised the Foundation for teaching kids capitalism! But is this any different from giving kids pocket money for doing chores? Having said that, there are currently 100+ apps and at the time of writing only eleven cost money... and you can buy them all and still have change from US\$20.00/£13.00.

The Pi Store content is divided into five categories; Games, Apps, Tutorials, Dev Tools

and Media. Before we explore each of these areas here are some navigation tips that will help you find the content you want.

In the Explore tab of the Pi Store there is an option to filter the content by status and also an option to specify the sort order. If you want to explore content which is still work-in-progress then change the status filter to In Progress. You can also set it to Show All to see all Pi Store content.

There are many sort options, but the most useful are Most Played, Newest First and Top Rated. Note that currently the Pi Store does not store these settings so the next time you open the Pi Store the status will likely be reset to Finished and the sort order will be reset to Price - Highest.

Several programs in the Pi Store do not run on LXDE and require a reboot before they start. Although there is a warning on the application page in the Pi Store, there is no final "Are you sure?" after you click on Launch. So make sure you have everything saved first.

Don't forget to tip!

When you receive good service you leave a tip. Almost everything in the Pi Store is free. If you enjoyed playing a game or found a title useful, consider showing your appreciation by leaving a tip for the developer. It's easy to do. In your library select the title you want to tip then click View Details. In the details page click Tip this Project to send \$1.00/£1.00 by default.



Games

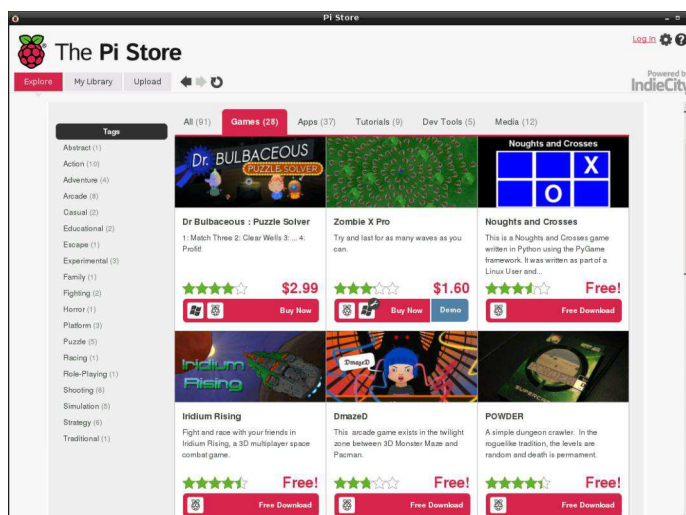

Unsurprisingly this is the largest category in the Pi Store. With 48 titles at the time of writing there is something for all gamers here.

In **Dr Bulbaceous : Puzzle Solver** (US\$2.99/£1.99) you drop different coloured objects and when 3 or more are touching they disappear. The goal is to clear the screen before the objects reach the top. Although I found the game too easy, kids will enjoy it. It is colourful and well implemented. Tip: To swap your current object for something more potent, press the Enter key. It looks like the mouse should work, but it didn't for me.

Martian Invaders (\$1.60/£1.00) is a retro space shooter that allows keyboard or joystick control.

DmazeD is a lot of fun. You search a maze for the key to the exit, but it is dark so you have a limited field of vision. Listen out for the monster that is also in the maze with you!

Another game I found myself thoroughly enjoying is **The Little Crane That Could**. Through dexterous use of your crane and its many movements you complete a series of increasingly difficult tasks.

Many folks of a certain age (like myself!) use their Raspberry Pi to relive the golden age of home computing and there is no shortage of games inspired from that decade. In the Pi Store these include **Abandoned Farmhouse**

Adventure and **King's Treasure** - classic text based adventures, **Chocolate Doom** - play all versions of Doom, **NXEngine** - a clone of the "Cave Story" platformer, **Star Flite** - a Star Trek retro game plus an emulator for the **Atari800**.

Other excellent games include **Freeciv** - an empire building strategy game, **Sqrxz 2**, **Sqrxz 3** and **Sqrxz 4** - platformers, the impressive **Open Arena** - first person shooter and **OpenTTD** - a simulation game based on Transport Tycoon Deluxe. Alas the promising **Iridium Rising** - a 3D space game, has been offline for over a year so you can ignore it.

The first commercial game on the Pi Store was **Storm In A Teacup**. It remains one of my favourite Raspberry Pi games, but unfortunately it was recently removed from the Pi Store. Hopefully it will be back soon.

Apps

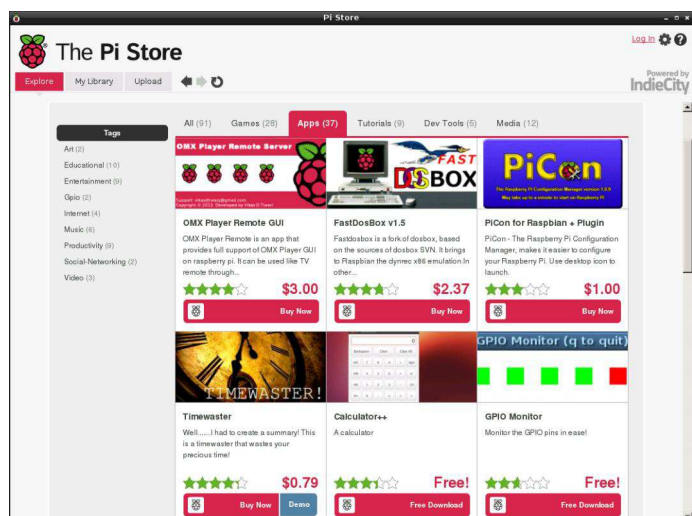

The second largest category in the Pi Store, there is an incredible selection of titles ranging from utilities to emulators to media programs to 'heavy-weight' applications. Examples of the latter are **Asterisk** - a PBX system and the brilliant **LibreOffice** - a Microsoft Office compatible and equivalent office suite.

Four of the eleven paid applications can be found here. **100 Tools Swiss File Knife** (US\$1.99/£1.99) provides 100 command line tools such as a simple FTP server, find/replace

text in files, treesize, split/join files, create/check md5 checksums, print coloured text to the terminal... and much, much more.

OMX Player Remote GUI (US\$3.00/ £1.80) provides a web UI that can be used on a smart phone or tablet device to control OMX Player running on the Raspberry Pi. Simply enter the given URL in your web browser, specify your media folder and then have full control of playlists, volume and all the usual media controls.

FastDosBox (US\$2.37/£1.35) is a fast 386 based PC emulator and is a great way to run 90's era DOS based games. Another similar program on the Pi Store is **RPix86**.

PiCon (US\$1.00/£0.60) is a very flexible configuration manager for hardware tweaking. It provides a GUI for overclocking every aspect of the Raspberry Pi, but for me its real strength is with its video configuration. Visually get the perfect monitor setup quickly and easily. No more black bars! Multiple presets can be saved so if you take your Raspberry Pi to different locations (e.g. school, Raspberry Jam, hackspace) you can get the best display configuration quickly without changing your 'home' settings.

I was not familiar with **XIX Music Player**, but it is pleasantly surprising and is definitely worth downloading. (Change the Status to "In Progress" to see this). I am using it to listen to internet radio (Absolute Radio from the UK, Hit FM from Belgium, MacJingle Heartbeat from Austria...) while I layout this article using Scribus and all running smoothly on the Raspberry Pi.

Staying with the music theme there are two music creation applications in the Pi Store. **Schism Tracker** is both a MOD file player and a music composition tool. Basic instructions explaining its operation are in issues 2, 12 and 13 of The MagPi.

With **PXDRUM** you will have a lot of fun creating

cool beats. You can simultaneously play eight different percussion instruments and change their sound by loading different drum kits. Start with one of the demo songs and get your groove on!

Tutorials

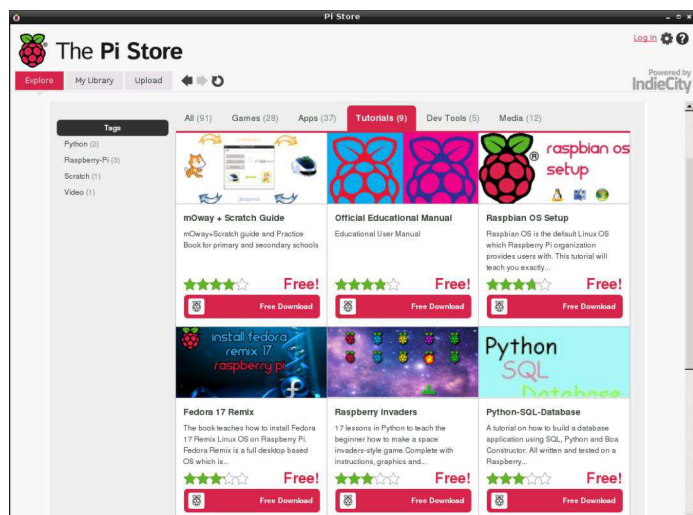

The Tutorials category contains several very useful guides including the **Official Raspberry Pi Educational User Manual**. Other guides include **Python-SQL-Database** - a tutorial on how to create database applications using SQL and Python plus **Raspberry Invaders** - a Python programming course with 17 lessons where you learn how to create a space invaders style game using Python.

Dev Tools

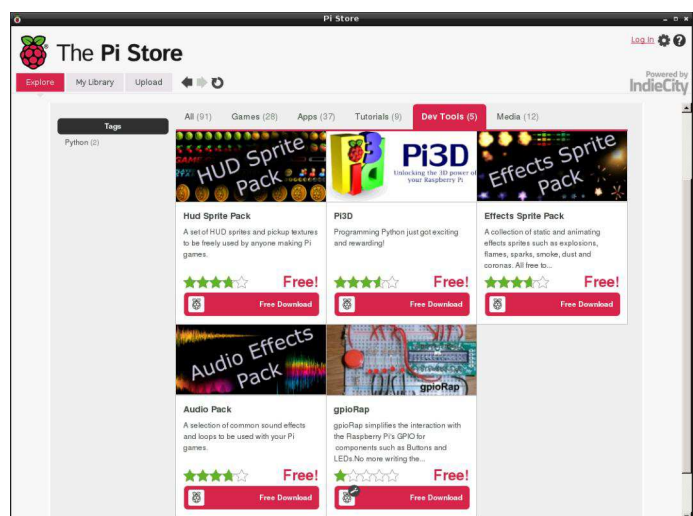

This is the smallest category in the Pi Store yet it contains useful collections such as **HUD Sprite Pack**, **Effects Sprite Pack** and **Audio Effects**

Pack for your Python and Scratch games plus **Michelle's Minetools** and **GLG Toolkit**... of course all free to use.

There is also the very excellent **Pi3D**, a Python module that simplifies developing 3D worlds and provides access to the power of the Raspberry Pi GPU. In addition to both 3D and 2D rendering, Pi3D can load textures, models, create fractal landscapes and offers vertex and fragment shaders. There are also 19 impressive demos.

Media

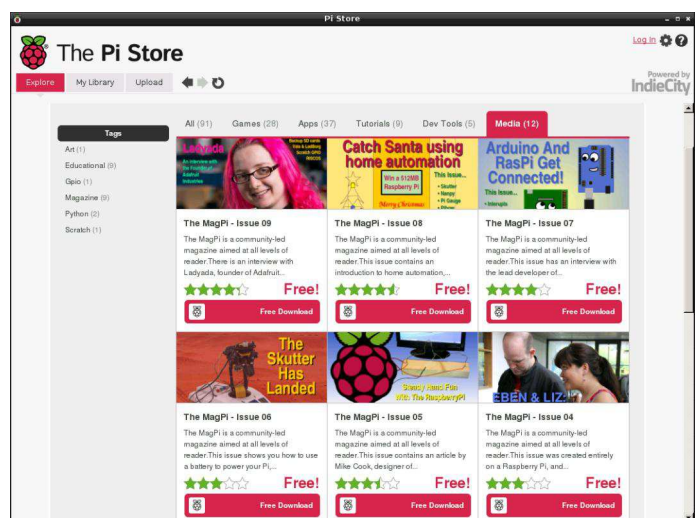

Last, but certainly not least, is the Media category. This is where you will find every issue of **The MagPi** - the first, and in my biased opinion the best, magazine for the Raspberry Pi... and of course it is free! There will typically be a short lag between The MagPi being released at the start of each month and it appearing in the Pi Store. That is because the Pi Store version is the same version that we use for creating the printed version of the magazine so we are doubly thorough with the quality control.

Conclusion

With over 4 million Raspberry Pis sold worldwide and the Pi Store being located on the desktop of Raspbian, it has the potential to be an incredible resource and the "go to" place for Raspberry Pi content. It is easy to upload so why not share your original programs or tutorials with others? The Pi Store is there for your benefit and the benefit of the community, so go use it.

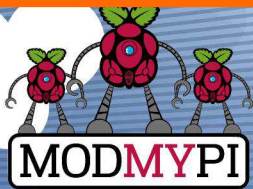

PHYSICAL COMPUTING



Jacob Marsh

ModMyPi

Buttons and switches with the Raspberry Pi

SKILL LEVEL : BEGINNER

Buttons and switches are a fundamental part of 'physical' computing. This beginner's tutorial is designed to teach the basics of physical operation and programming with the Raspberry Pi using a simple momentary switch setup.

The tutorial requires a few simple components that are available from ModMyPi (product codes in brackets):

- Medium Breadboard (BB2) – for laying out our components & circuit.
- Male to Female Jumper Wires (JW8) – for jumping between the Raspberry Pi & breadboard.
- PCB Mount Switch (TAC001) – a four point basic momentary switch.
- ModMyPi's Ridiculous Resistor Kit (RK995) – to protect your Pi & calibrate the float voltage.
- 10K Ω Resistor - (Brown, Black, Black, Red, Brown)
- 1K Ω Resistor - (Brown, Black, Black, Brown, Brown)
- Breadboard Jumper Wire Kit (140KI) – for easy jumping on the breadboard.

The circuit

The purpose of this circuit is to enable the Raspberry Pi to detect a change in voltage and run a program when the button (Switch 1) is pressed. This requires three GPIO pins on our Raspberry Pi: the first will provide a signal voltage of 3.3V (Vcc), the next will

ground the circuit (GND) and the third will be configured as an input (GPIO IN) to detect the voltage change.

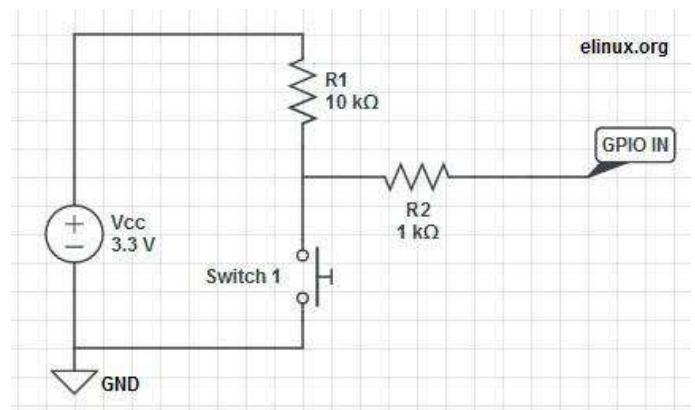

When a GPIO pin is set to input, it doesn't provide any power and consequently has no distinct voltage level; defined as 'floating'. We need the pin to be capable of judging the difference between a high and low voltage, however in a floating state it's liable to incorrectly detect states due to electrical noise. To enable the pin to see the difference between a high or low signal we must 'tie' that pin, calibrating it to a defined value; 3.3V in this case!

To tie the input pin, we connect it to the Vcc 3.3V pin, hence when Switch 1 is open, the current flows through GPIO IN and reads high. When Switch 1 is closed, we short the circuit and the current is pulled to GND; the input has 0V and reads low! The large R1 (10k Ω) resistor in this circuit ensures that only a

little current is drawn when the switch is pressed. If we don't use this resistor, we are essentially connecting Vcc directly to GND, which would allow a large current to flow, potentially damaging the Pi! To make the circuit even safer in case we get something wrong, we add the R2 (1kΩ) resistor to limit the current to and from GPIO IN.

The switch

Four point switches are wired in a very similar manner to two point switches. They're simply more versatile as you can have multiple isolated inputs into the same switching point. Checking the diagrams, pins 1 & 2 are always connected, as are pins 3 & 4. However, both pin pairs are disconnected from each other when the button is not pressed i.e. pins 1 & 2 are isolated from pins 3 & 4. When the button is pressed the two sides of the switch are linked and pins 1, 2, 3 & 4 are all connected!

In 'momentary' switches the circuit disconnects when pressure is removed from the button, as opposed to 'toggle' switches when one push connects and the next push disconnects the internal switch circuit.

Where does it all go?

WARNING. When hooking up to GPIO points on your Raspberry Pi care must be taken, as connecting the wrong points could permanently damage your Raspberry Pi. Please use a GPIO cheat-sheet, and double check everything before switching it on. I will denote each GPIO point by its name and physical location, for example GPIO P17 is actually located at pin 11, denoted: GPIO P17 [pin 11]. The irregularities are a result of the pin names being referenced by the on board chip rather than their physical location.

1. Connect the Raspberry Pi to the Ground Rail. Use a black jumper wire to connect GPIO GND [pin 6] on the Pi to the Negative rail on the breadboard – the rail on the edge of the board with the negative sign (-).

2. Connect the Raspberry Pi 3.3V to the Positive Rail.

Use a red jumper wire to connect GPIO 3.3V [pin 1] on the Pi to the Positive rail on the breadboard – the edge rail with the positive sign (+).

3. Plug in your switch. When breadboarding, make sure all of the legs are in separate rows. To achieve this, straddle the central channel on the breadboard.

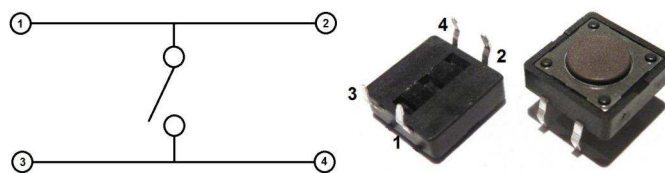

4. Add the 10kΩ resistor. Connect this from Switch pin 1 to the positive (+) rail of the breadboard. Orientation of standard film resistors is unimportant.

5. Connect the switch to Ground. Use a breadboard jumper wire to hook switch pin 3 to the ground (-) rail.

6. Connect the switch to the 1kΩ resistor. Add this resistor between switch pin 1 and the 10kΩ resistor and take it to a clear rail.

7. Connect the switch to the Signal Port. We'll be using GPIO P17 to detect the 3.3V signal when the switch is pressed. Simply hook up a jumper between GPIO P17 [pin 11] on the Raspberry Pi and the 1kΩ resistor rail.

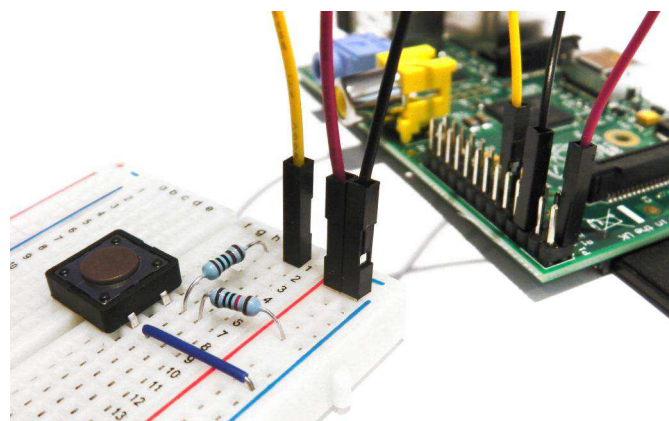

That's our circuit built! In the next article, we'll write a simple program in Python to run when we press the switch!

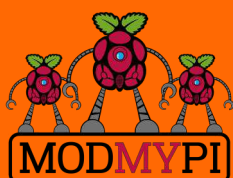

This article is
sponsored by
ModMyPi

All breakout boards and accessories used in this tutorial are available for worldwide shipping from the ModMyPi webshop at www.modmypi.com

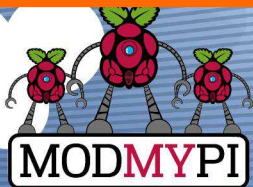

PHYSICAL COMPUTING



Jacob Marsh

ModMyPi

Buttons and switches with the Raspberry Pi - Part 2

SKILL LEVEL : BEGINNER

Buttons and switches are a fundamental part of physical computing. This beginners tutorial is designed to teach the basics of physical operation with the Raspberry Pi using a simple momentary switch setup. In the previous article, we discussed and built our switch circuit. In this part we will go through the steps of programming and interacting between the Raspberry Pi and our components. The coding part of this tutorial is in Python, a widely used general purpose language. It is also very readable, so we can break down and explain the function of each line of code. The purpose of our code will be to read the I/O pin when the switch is pressed!

Using a switch

If you have not already done so, start X by typing `startx` and load the program `IDLE3`. Since we are starting a new project, open up a new window `File > New Window`. Remember that Python is case sensitive and indentation is fundamental. Indentation, which is used to group statements, will occur automatically as you type commands so make sure you stick to the suggested layout. The first line of our code imports the Python library for accessing the GPIO.

```
import RPi.GPIO as GPIO
```

Next we need to set our GPIO pin numbering, as either the `BOARD` numbering or the `BCM` numbering. `BOARD` numbering refers to the physical pin numbering of the headers. `BCM` numbering refers to the channel numbers on the Broadcom chip. Either will do, but I personally prefer `BCM` numbering. If you're confused, use a [GPIO cheat sheet](#) to clarify which pin is which!

```
GPIO.setmode(GPIO.BCM)
```

Now you need to define the GPIO pins as either inputs or outputs. In part 1 we set `BCM Pin 17 / BOARD Pin 11 (GPIO P17 [Pin 11])` as our input pin. So our next line of code tells the GPIO library to set this pin as an input.

```
GPIO.setup(17, GPIO.IN)
```

In part 1 of the tutorial, the input pin was tied high by connecting it to our 3.3V pin. The purpose of our Python program is to check to see if the input pin has been brought low e.g. when the button has been pressed. To check the high/low status of the pin we are going to use a `True` or `False` statement within an infinite loop. We need to tie

our True statement to the high value of our input pin. To do so we need to create a new variable called `input_value` and set it to the current value of GPIO P17 [Pin 11].

```
while True:
    input_value = GPIO.input(17)
```

The next step is to add a condition that will print something when the button is pressed. For this we will use a False condition. The `input_value` is False when the button is pressed and the associated signal is pulled low. This can be checked with a simple Python `if` statement.

```
if input_value == False:
    print("Who pressed my button?")
```

When the button is pressed the program will now display the text, "Who pressed my button?". Feel free to change this to anything you want.

```
while input_value == False:
    input_value = GPIO.input(17)
```

The last two lines in the above code are very important, they create a loop that tells Python to keep checking the status of GPIO P17 [Pin 11] until it's no longer low (button released). Without this, the program would loop while the button is still being pressed meaning the message will be printed multiple times on the screen before you release the button. The final program should look like this in Python:

```
import RPi.GPIO as GPIO
GPIO.setmode(GPIO.BCM)
GPIO.setup(17, GPIO.IN)
while True:
    input_value = GPIO.input(17)
    if input_value == False:
        print("Who pressed my button?")
        while input_value == False:
            input_value = GPIO.input(17)
```

Save the file as `button.py`. In order to run the program open a new terminal window on the

Raspberry Pi and type the following command:

```
sudo python button.py
```

At first nothing will happen, but if you press the button the program will print the defined message. To exit a running Python script, simply press `<CTRL>+C` on the keyboard to terminate. If it hasn't worked don't worry. First check the circuit is connected correctly on the breadboard as defined in part 1, then check that the jumper wires are connected to the correct pins on the GPIO port. If it still fails to work, double check each line of the program is correct remembering that Python is case-sensitive and check that the indentation is correct. I find that typing the code out by hand will give better results than a simple copy/paste. This is a deceptively simple program that can be used for many purposes. The same code could be used to read when the pins of separate devices, such as a sensor or external micro-controller, have been pulled high or low.

Adding an LED

We will carry on using the same breadboard as before but we require a couple of extra components:

- An LED (light emitting diode), any colour you like.
- ModMyPi's Ridiculous Resistor Kit (RK995)
 - * 330Ω resistor - (Orange, Orange, Black, Black, Brown)

An output pin on the GPIO port can be set to either 0V (low) or 3.3V (high). Our expansion circuit will wire up an LED between an output pin and a ground pin on the Raspberry Pi's GPIO port. We'll be using Python to trigger our output pin high, causing a current to pass through the LED, lighting it up! We also add a 330Ω resistor to limit the current that is passed through the LED.

For this exercise we will connect the LED to GPIO P18 [Pin 12] which will be defined later in

our program as an output. We will use the same ground pin GPIO GND [Pin 6] as before, which is already connected to the negative rail (-) on our breadboard.

Building the Circuit

1. Connect GPIO output to breadboard. Use a green jumper wire to connect GPIO P18 [Pin12] on the Pi to an empty row on the breadboard.

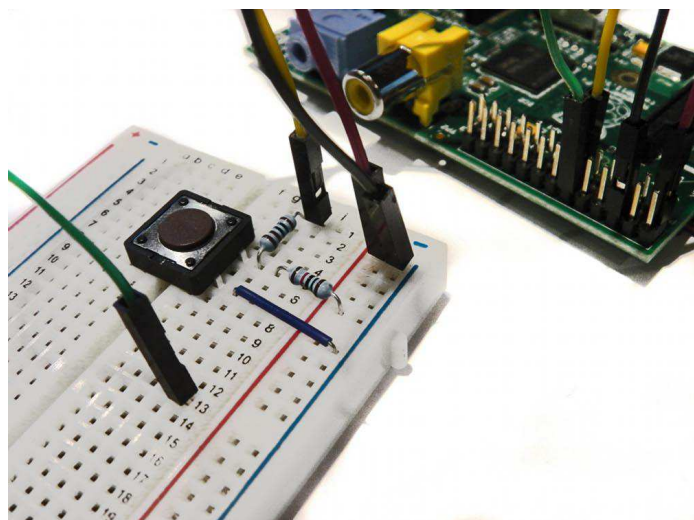

2. Add an LED. Insert the long leg (anode) of the LED into the same row as the green jumper wire and insert the shorter leg (cathode) into another empty row on the breadboard. Note: Make sure the LED is inserted the correct way round as it will only allow current to pass through it in one

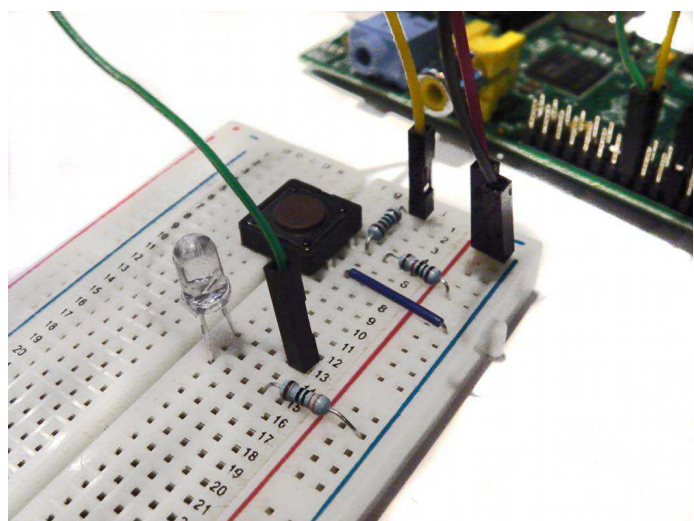

direction. If it's wrong it won't light up!

3. Add the 330Ω resistor. Connect the resistor between the cathode of the LED and the negative rail (-) on the breadboard. This protects our LED from burning out by way of too much current.

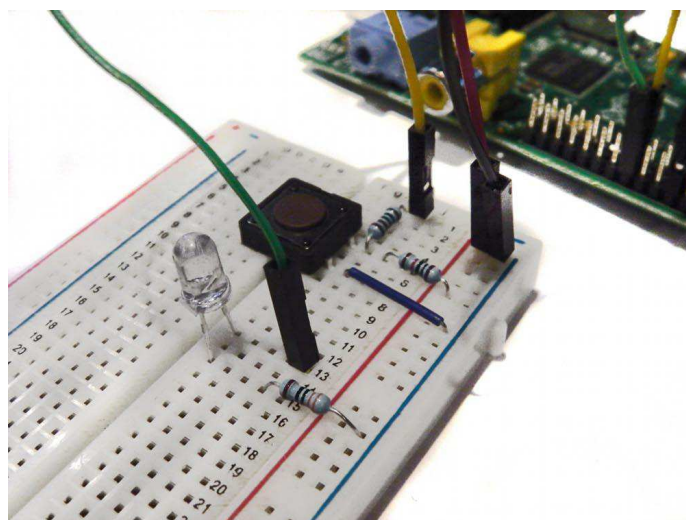

And that's our circuit built!

Next time

In the next article, we'll add a timer function to our script and a trigger function for our LED. As the script will be more complicated, it requires a proper clean-up function, so we'll code that in too!

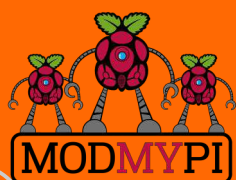
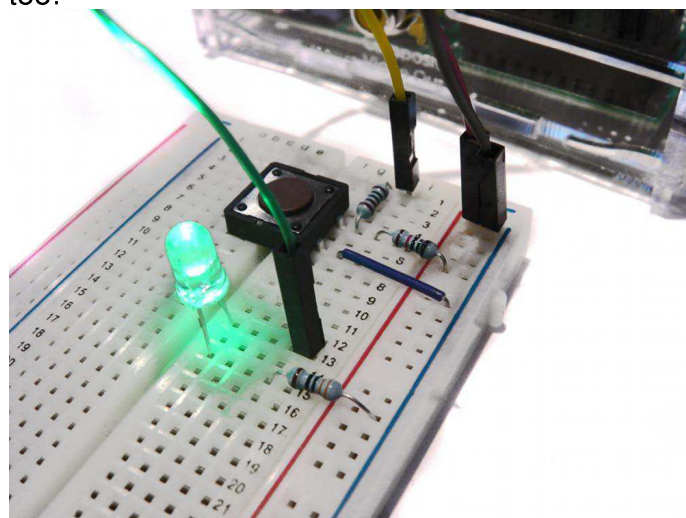

This article is
sponsored by
ModMyPi

All breakout boards and accessories used in this tutorial are available for worldwide shipping from the ModMyPi webshop at www.modmypi.com

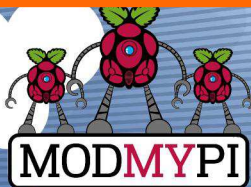

PHYSICAL COMPUTING



Jacob Marsh

ModMyPi

Buttons and switches with the Raspberry Pi - Part 3

SKILL LEVEL : BEGINNER

In the previous article we built a simple button circuit connected to our Raspberry Pi via the GPIO ports and programmed a Python script to execute a command when the button was pressed. We then expanded our circuit with an LED. In this tutorial, we will be expanding our script to include timer and trigger functions for our LED. As the script will be more complicated, it requires a proper clean-up function. Start by reading the previous two articles before trying this one!

Adding LED control code

Now that our LED expansion circuit has been built, we will add some code into our previous program. This additional code will make the LED flash on and off when the button is pressed. Start by booting your Raspberry Pi to the Raspbian GUI (startx). Then start IDLE3 and open the previous example program `button.py`. Save this file as `button_led.py` and open it.

Since we want the LED to flash on and off, we will need to add a time function to allow Python to understand the concept of time. We therefore need to import the time module, which allows various time related functionality to be used. Add another line of code underneath line 1:

```
import time
```

Next, we need to define GPIO P18 [Pin 12] as an output to

power our LED. Add this to our GPIO.setup section (line 4), below the input pin setup line:

```
GPIO.setup(18, GPIO.OUT)
```

Once GPIO P18 [Pin 12] has been set as an output, we can turn the LED on with the command `GPIO.output(18, True)`. This triggers the pin to high (3.3V). Since our LED is wired directly to this output pin, it sends a current through the LED that turns it on. The pin can also be triggered low (0V) to turn the LED off, by the command `GPIO.output(18, False)`.

Now we don't just want our LED to turn on and off, otherwise we would have simply wired it to the button and a power supply. We want the LED to do something interesting via our Raspberry Pi and Python code. For example, let us make it flash by turning it on and off multiple times with a single press of the button!

In order to turn the LED on and off multiple times we are going to use a for loop. We want the loop to be triggered when the button has been pressed. Therefore, it needs to be inserted within the if condition 'if input_value == False:', that we created in our original program. Add the following below the line 'print("Who pressed my button!")' (line 9), making sure the indentation is the same:

```
for x in range(0, 3):
```

Any code below this function will be repeated three times. Here the loop will run from 0 to 2, therefore running 3 times. Now we will add some code in the loop, such that the LED flashes on and off:

```
GPIO.output(18, True)
time.sleep(1)
GPIO.output(18, False)
time.sleep(1)
```

The LED is triggered on with the command `GPIO.output(18, True)`. However, since we do not want to immediately turn it back off, we use the function `time.sleep(1)` to sleep for one second. Then the LED is triggered off with the `GPIO.output(18, False)` command. We use the `time.sleep(1)` function again to wait before the LED is turned back on again.

The completed program should be of the form:

```
import RPi.GPIO as GPIO
import time
GPIO.setmode(GPIO.BCM)
GPIO.setup(17, GPIO.IN)
GPIO.setup(18, GPIO.OUT)
while True:
    input_value = GPIO.input(17)
    if input_value == False:
        print("Who pressed my button?")
        for x in range(0, 3):
            GPIO.output(18, True)
            time.sleep(1)
            GPIO.output(18, False)
            time.sleep(1)
        while input_value == False:
            input_value = GPIO.input(17)
```

Save the file and open a new terminal window. Then type the following command:

```
sudo python button_led.py
```

This time when we press the button a message will appear on the screen and the LED should also flash on and off three times!

To exit the program script, simply type `<CTRL>+C` on the keyboard to terminate it. If it hasn't worked do not worry. Do the same checks we did before. First, check the circuit is connected correctly on the breadboard. Then check that the jumper wires are connected to the correct pins on the

GPIO port. Double check the LED is wired the right way round. If the program still fails, double check each line of the program, remembering that Python is case-sensitive and correct indentation is needed.

If everything is working as expected, you can start playing around a bit with some of the variables. Try adjusting the speed the LED flashes by changing the value given to the `time.sleep()` function.

You can also change the number of times that the LED flashes by altering the number of times that the `for` loop is repeated. For example if you wanted the LED to flash 30 times, change the loop to `'for x in range(0, 30)'`.

Have a go playing around with both of these variables and see what happens!

Exiting a program cleanly

When a program is terminated due to an error, a keyboard interrupt (`<CTRL>+C`) or simply because it's come to an end, any GPIO ports that were in use will carry on doing what they were doing at the time of termination. Therefore, if you try to run the program again, a warning message will appear when the program tries to 'set' a pin that's already in use from the previous execution of the program. The program will probably run fine, but it is good practice to avoid these sorts of messages, especially as your programs become larger and more complex!

To help us exit a program cleanly we are going to use the command `GPIO.cleanup()`, which will reset all of the GPIO ports to their default values.

For some programs you could simply place the `GPIO.cleanup()` command at the end of your program. This will cause the GPIO ports to be reset when the program finishes. However, our program never ends by itself since it constantly loops to check if the button has been pressed. We will therefore use the `try` and `except` syntax, such that when our program is terminated by a keyboard interruption, the GPIO ports are reset automatically.

The following Python code is an example of how the `try` and `except` commands can be used together to exit a program cleanly.

```

# Place any variable definitions and
# GPIO set-ups here

try:

# Place your main block of code or
# loop here

except KeyboardInterrupt:
    GPIO.cleanup()

# Program will end and GPIO ports
# cleaned when you hit CTRL+C

finally:
    GPIO.cleanup()

```

Note that Python will ignore any text placed after hash tags (#) within a script. You may come across this a lot within Python, since it is a good way of annotating programs with notes.

After we have imported Python modules and setup our GPIO pins, we need to place the main block of our code within the try condition. This part will run as usual, except when a keyboard interruption occurs (<CTRL>+C). If an interruption occurs the GPIO ports will be reset when the program exits. The finally condition is included such that if our program is terminated by accident, if there is an error without using our defined keyboard function, then the GPIO ports will be cleaned before exit.

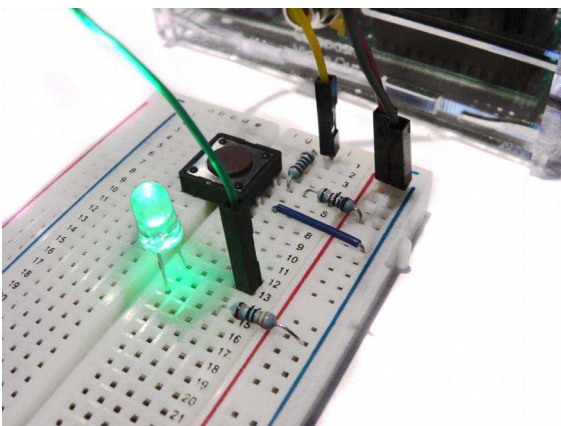

Open `button_led.py` in IDLE3 and save it as `button_cleanup.py`. Now we can add the code previously described into our script. The finished program

should have the form:

```

import RPi.GPIO as GPIO
import time
GPIO.setmode(GPIO.BCM)
GPIO.setup(17, GPIO.IN)
GPIO.setup(18, GPIO.OUT)
try:
    while True:
        input_value = GPIO.input(17)
        if input_value == False:
            print("Who pressed my button?")
            for x in range(0, 3):
                GPIO.output(18, True)
                time.sleep(1)
                GPIO.output(18, False)
                time.sleep(1)
            while input_value == False:
                input_value = GPIO.input(17)
except KeyboardInterrupt:
    GPIO.cleanup()
# Program will end and GPIO ports cleaned
# when you hit CTRL+C
finally:
    GPIO.cleanup()

```

Notice that only the loop part of the program is within the try condition. All our imports and GPIO set-ups are left at the top of the script. It is also important to make sure that all of your indentations are correct!

Save the file. Then run the program as before in a terminal window:

```
sudo python button_cleanup.py
```

The first time you run the file, you may see the warning message appear since the GPIO ports have not been reset yet. Exit the program by pressing <CTRL>+C. Then run the program again and hopefully this time no warning messages will appear!

This extra code may seem like a waste of time because the program still runs fine without it! However, when we are programming, we always want to try and be in control of everything that is going on. It is good practice to add this code, to reset the GPIO when the program is terminated.

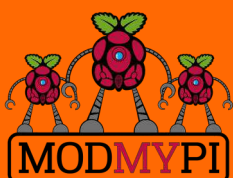

This article is
sponsored by
ModMyPi

All breakout boards and accessories used in this tutorial are available for worldwide shipping from the ModMyPi webshop at www.modmypi.com



Lewis Callaway

Guest Writer

Garage door automation with WebIOPi

SKILL LEVEL : BEGINNER

Introduction

Have you ever opened your garage door, but then forgot to shut it later? In this article I will show you how to open and close your garage door over the internet, using a Raspberry Pi, a relay and WebIOPi. There is even a webcam attached to the Raspberry Pi, such that you can visually confirm that the door is really closed.

Before you start

These instructions assume that sshd is running on Raspbian. For older images, you can enable sshd using:

```
sudo raspi-config
```

and then enable SSH via Advanced Options.

Parts needed

You will need the following parts:

- Raspberry Pi Model B
- 12V relay
- Adafruit Small-Size Perma-Proto breadboard
- female jumper wires
- regular hookup wire
- 1N4001 diode
- webcam that does not require a powered hub

The tools needed are a soldering iron, screwdriver, wire strippers and wire cutters.

[Ed: Check the specification of your garage door and choose a relay that is appropriate for the voltage and current. It may be necessary to use a transistor/FET driver with the relay.]

Installing WebIOPi

The framework we are going to use to control the relay is WebIOPi. *[Ed: WebIOPi was first introduced in issues 9 and 10 of The MagPi.]* To install this package, from the command line enter:

```
wget http://sourceforge.net/projects/webiopi/files/WebIOPi-0.7.0.tar.gz
tar xvzf WebIOPi-0.7.0.tar.gz
cd WebIOPi-0.7.0
sudo ./setup.sh
```

Then configure WebIOPi to start when the Raspberry Pi boots, and then reboot:

```
cd
sudo update-rc.d webiopi defaults
sudo reboot
```

Wait for a minute after rebooting the Raspberry Pi. Then open a web browser and enter the IP

address of the Raspberry Pi followed by the port number of WebIOPi which is 8000, e.g. <http://192.168.2.15:8000>.

When connecting to the Raspberry Pi using the web browser, a login screen will appear.

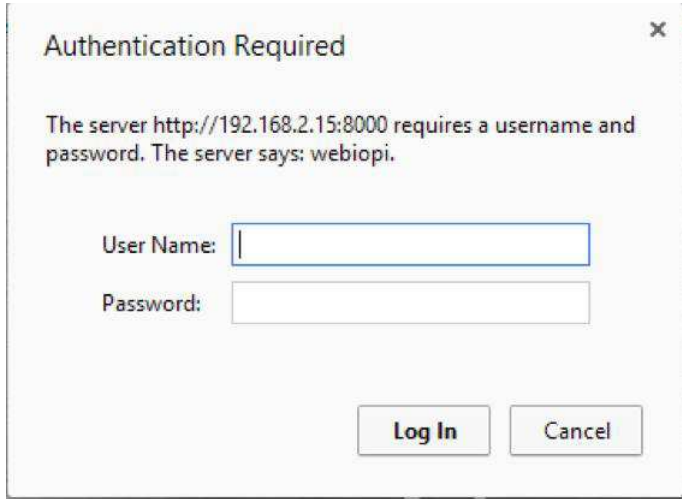

The default login is:

```
User Name: webiopi
Password: raspberry
```

The next screen shows a virtual representation of the Raspberry Pi's GPIO pins. The relay can be connected between a ground pin and a GPIO pin. To activate the relay, click on the corresponding button to set it as an OUTPUT instead of an INPUT. Now when the GPIO pin is selected, it will send a voltage to the relay connected to it.

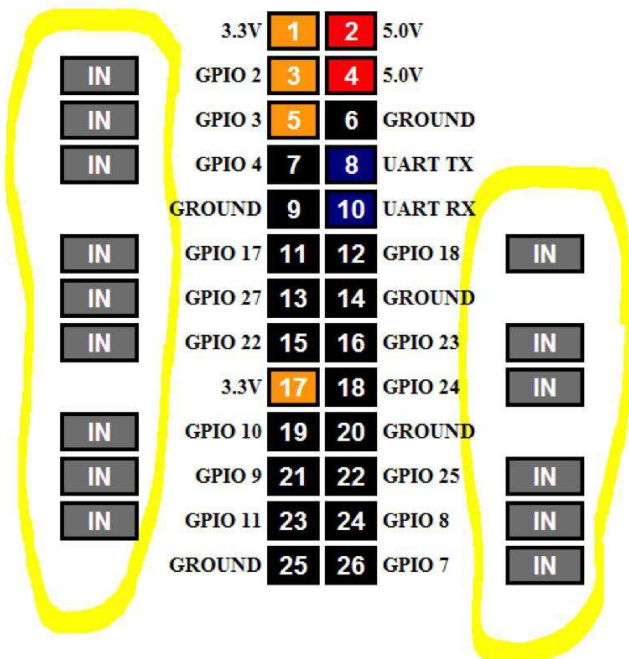

Configuration

To make the interface cleaner, WebIOPi can be configured to offer one button instead of many small ones.

Create folders to store the files:

```
mkdir -p garage/html
mkdir garage/python
```

The next step is to create a python file that helps the HTML file control the garage door opener.

```
nano garage/python/script.py
```

Now copy the code below into the new file.

```
import webiopi
GPIO = webiopi.GPIO
Garage = 17 # GPIO pin using BCM numbering
# setup function is automatically called at
# WebIOPi startup
def setup():
    # set the GPIO used by the light to output
    GPIO.setFunction(Garage, GPIO.OUT)

# loop function, repeatedly called by WebIOPi
def loop():
    # gives CPU some time before looping again
    webiopi.sleep(1)
```

Then press CTRL-X and then Y to save the file. WebIOPi will access this python script using an HTML page that contains the single button. Use nano to create a new HTML file,

```
nano garage/html/index.html
```

Then copy the HTML from the next page of this article into the file and save it.

```

<!DOCTYPE html PUBLIC "-//W3C//DTD HTML 4.01 Transitional//EN">
<html>
<head>
  <meta http-equiv="Content-Type" content="text/html; charset=UTF-8">
  <title>Garage Control</title>
  <script type="text/javascript" src="/webiopi.js"></script>
  <script type="text/javascript">
    webiopi().ready(function() {
      // Create a "Light" labeled button for GPIO 17
      var button = webiopi().createGPIOButton(17, "Garage");

      // Append button to HTML element with ID="controls" using jQuery
      $("#controls").append(button);

      // Refresh GPIO buttons
      // pass true to refresh repeatedly of false to refresh once
      webiopi().refreshGPIO(true);
    });
  </script>
  <style type="text/css">
    button {
      display: block;
      margin: 5px 5px 5px 5px;
      width: 1280px;
      height: 720px;
      font-size: 100pt;
      font-weight: bold;
      color: white;
    }

    #gpio17.LOW {
      background-color: Black;
    }
    #gpio17.HIGH {
      background-color: Yellow;
    }
  </style>
</head>
<body>
  <div id="controls" align="center"></div>
</body>
</html>

```

To use the Python script and new HTML file, modify the WebIOPi configuration file:

```
sudo nano /etc/webiopi/config
```

Find the [SCRIPTS] section and add the following line:

```
garage = /home/pi/garage/python/script.py
```

Then find the [HTTP] line and add the following

line:

```
doc-root = /home/pi/garage/html
```

Lastly, find the [REST] line and add the following lines:

```
gpio-export = 17
gpio-post-value = true
gpio-post-function = false
```

Then save the file and reboot the Raspberry Pi:

```
sudo reboot
```

Motion setup

The motion package can be used with a webcam, to check the garage door's status. While this article uses a USB webcam, the Raspberry Pi camera can also be used. There are specific instructions for using the motion package with the Raspberry Pi camera at: <http://rbnrpi.wordpress.com/project-list/setting-up-wireless-motion-detect-cam/>

To use UVC camera support, make sure the latest stable firmware is installed by updating the Raspbian installation:

```
sudo apt-get update; sudo apt-get upgrade -y
```

Then install the motion package:

```
sudo apt-get install motion
```

Next, open the configuration file in nano:

```
sudo nano /etc/motion/motion.conf
```

Change `daemon off`, to `daemon on`. This will cause motion to run as a daemon process that runs in the background. The default resolution of 320x240 is a reasonable choice. Change `webcam_localhost on` to `off`. This allows the camera feed to be viewed from another device, instead of just from the Raspberry Pi. Now save the file.

To simplify the setup, motion can be configured to start when the Raspberry Pi boots by editing:

```
sudo nano /etc/default/motion
```

In this file change,

```
start_motion_daemon = no
```

to:

```
start_motion_daemon = yes
```

Then save the file and reboot the Raspberry Pi:

```
sudo reboot
```

Now that motion has been configured, plug in a Debian Wheezy compatible webcam. The webcam should then stream video to your Raspberry Pi's IP Address followed by `:8081`.

Hardware

The hardware in this project consists of a relay that allows the Raspberry Pi to switch a garage door opener on or off. To hookup the relay to the garage door opener, a Perma-Proto PCB was used. The relay was soldered directly to the Perma-Proto PCB, together with all the wires. To prevent an electrical short the bottom of the PCB was covered with electrical tape after the components were soldered on. A 1N4001 diode was placed across the relay coil pins, to avoid damaging the Raspberry Pi GPIO pin. **This is not optional.** If the diode is not used, it will eventually destroy the Raspberry Pi!

Use the datasheet for your relay to determine the pinout. There is an example below of how a relay can be connected. In the example, the Raspberry Pi connects to the coil with a diode in between the control (red wire) and ground (black wire) pins. The garage door is connected to the normally open pin and relay switch pin (two grey wires).

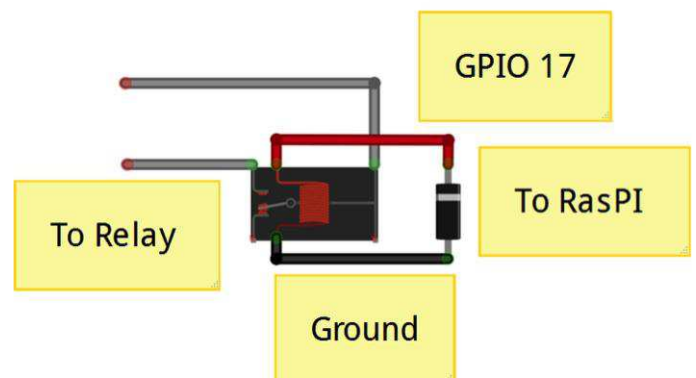

The coil on the relay should be connected to Ground and GPIO 17 on the Raspberry Pi using the female jumper wires.

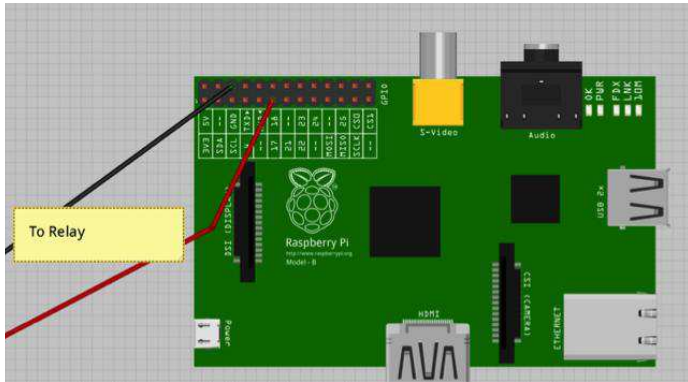

Soldering the Board

1. Cut and strip the two female jumper wires in half.

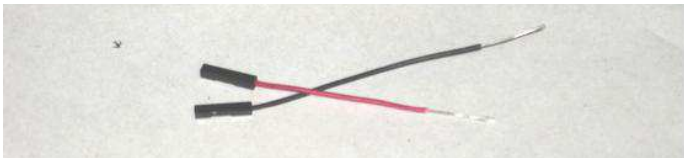

2. Solder the relay to the Perma-Proto board.

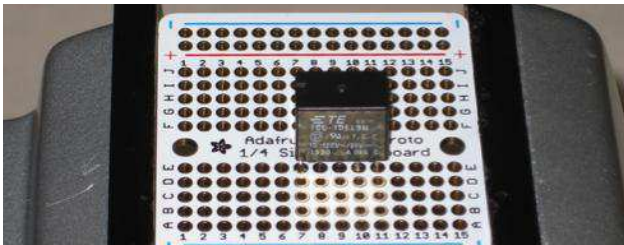

3. Next, solder the black female jumper wire to the coil on the relay and the red jumper wire to the coil on the relay. Then trim the excess wire from the bottom of the board.

4. To prevent the Raspberry Pi from being damaged, a 1N4001 diode is needed between the ground and control pins on the relay. The silver band on the diode needs to be connected to the control wire. Do not connect it to the ground.

5. Solder the wires that will connect to the garage door to the normally open pin and ground on the relay. Again, trim the excess wire after soldering.

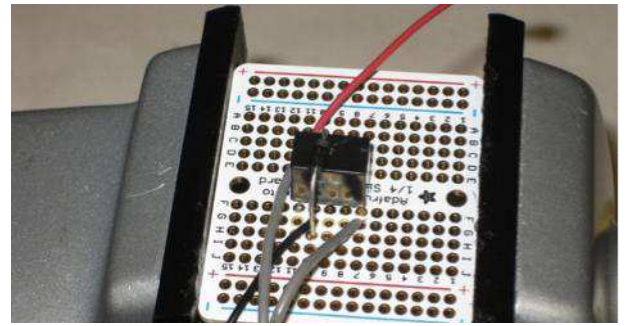

6. Lastly, cover the bottom of the board with electrical tape.

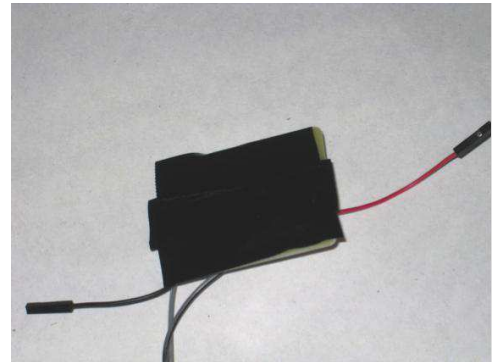

Once this is done, the PCB can be connected to the garage door opener.

Garage door opener connection

Be very careful when dealing with higher voltage circuits, such as a garage door opener. Before making any connections, make sure that the electrical power to the garage door is turned off. Then use a screwdriver to connect the wires from the relay to the garage door opener. If in doubt, consult the garage door opener manual, to check which wires to use.

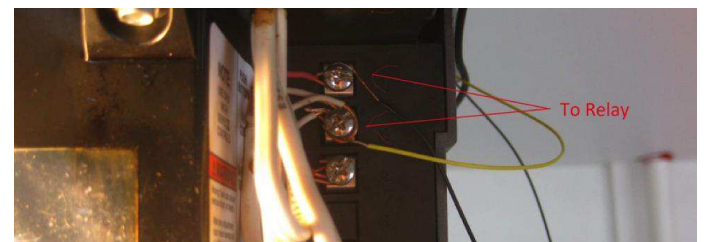

There is a video of the system working at: <https://www.youtube.com/watch?v=3glWnjPUQpl>

Information on accessing the Raspberry Pi outside the private local area network is given at: <http://www.wikihow.com/Set-Up-Port-Forwarding-on-a-Router>

Expand your Pi

Stackable Raspberry Pi expansion boards and accessories

ADC-DAC Pi

2x 12 bit analogue to digital channels and 2x 12 bit digital to analogue channels.

Serial Pi

RS232 serial communication board. Control your Raspberry Pi over RS232 or connect to external serial accessories.

ADC Pi

8 channel analogue to digital converter. I²C address selection allows you to add up to 32 analogue channels to your Raspberry Pi.

1 Wire Pi

1-Wire[®] to I²C host interface with ESD protection diode.

RTC Pi

Real-time clock with battery backup and 5V I²C level converter for adding external 5V I²C devices to your Raspberry Pi.

Servo Pi

16-channel, 12-bit PWM controller suitable for driving LEDs and radio control servos.

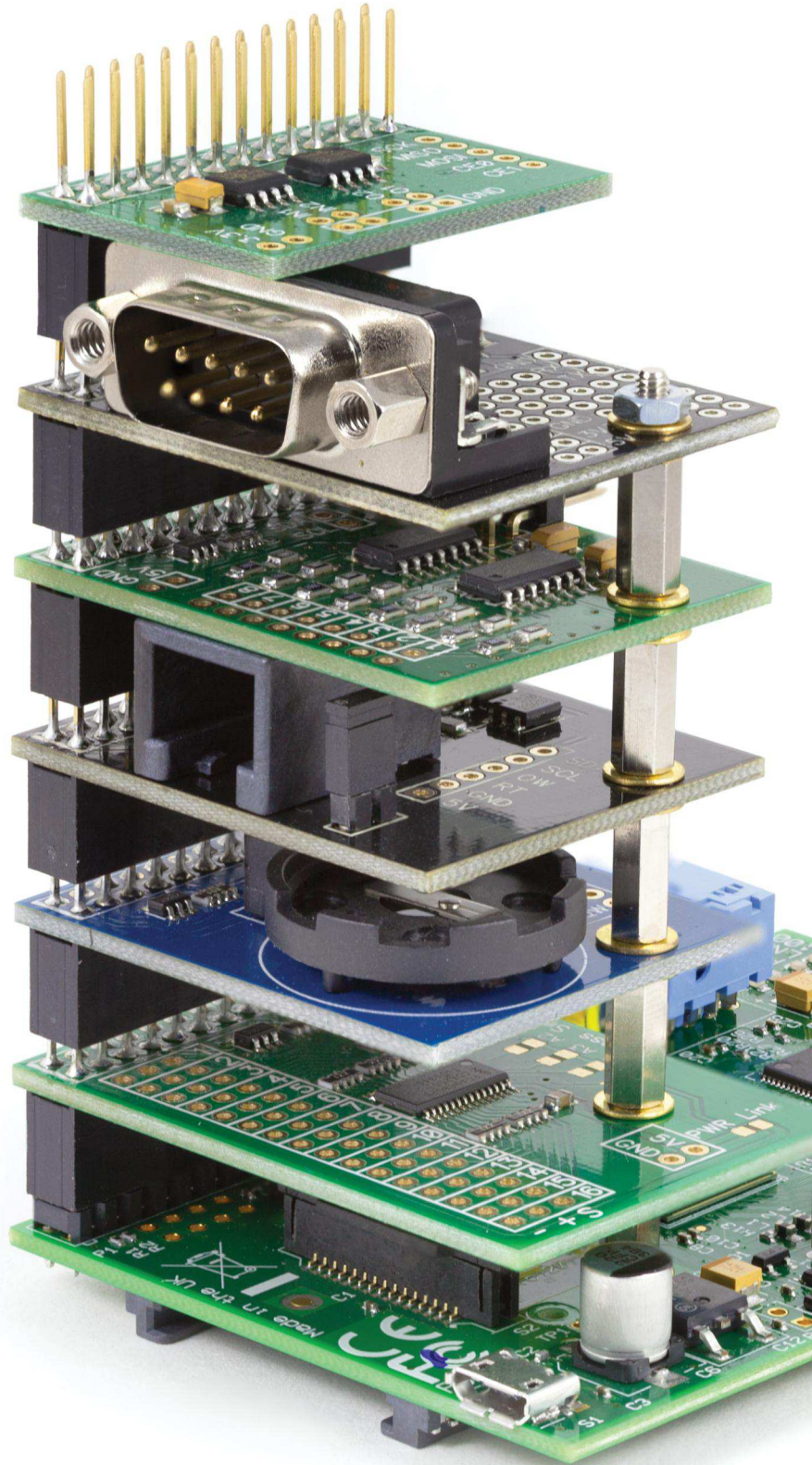



GPIO Rocks!



Michael Giles

Guest Writer

Build a magic wand with an accelerometer

SKILL LEVEL : INTERMEDIATE

Persistence of Vision displays create an image by quickly displaying one column of pixels at a time. When the device moves rapidly along a linear path the human eye can view the image as a whole as it is built up column by column. When I say rapid I mean rapid, at least one twenty-fifth of a second. At this speed an afterimage is seen in the retina and the viewer perceives the rapid succession of LED blinks as a full image.

Operation

The magic wand displays five columns of pixels for each specific letter in a user defined string. The accelerometer is used to determine which direction the wand is swinging to avoid displaying the string in reverse.



Project parts list

- 1x Raspberry Pi
- 1x Pi Prototyping kit (OpenElectrons.com)
- 1x LSM303 breakout (OpenElectrons.com)
- 1x SmartUPS (OpenElectrons.com)
- 1x PCF8574 chip, manufacturer part PCF8574ADW
- 1x 10uF through-hole capacitor, ESK106M050AC3AA
- 2x 82K through-hole resistors, 271-82K-RC
- 8x 4mm flat top red diff LEDs, HLMPM201

Obtaining parts

To build the circuit I used the Pi Prototyping Kit from OpenElectrons.com. It has multiple integrated circuit footprints and unwired through-holes for great prototyping flexibility.

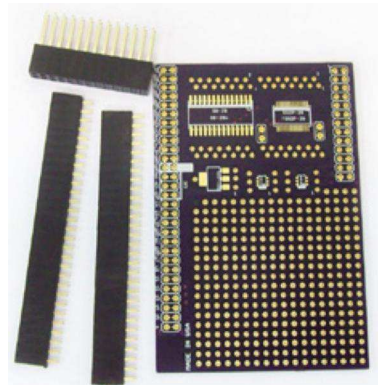

For the accelerometer I used the LSM303 breakout board, also from OpenElectrons.com.

Magic wand assembly

The circuit build for the magic wand required soldering of through-hole components as well as the surface mount

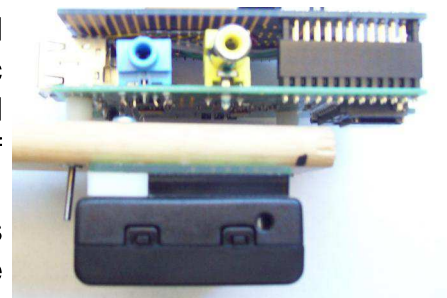

PCF8574 chip. The datasheet showed the In/Out ports of P0-P7 to which I connected the eight LEDs. In the first build I placed a bussed resistor array between the 5V power and the LEDs to limit the current, but when I tested I realized the lights were extremely difficult to see in the

daylight. I then shorted the resistor array and the LEDs became much more visible.

Connecting the LSM303 breakout was by far the simplest part. The Pi Prototyping board has two I²C female connections for a quick plug in for breakout boards.

The full schematic for the project is shown below.

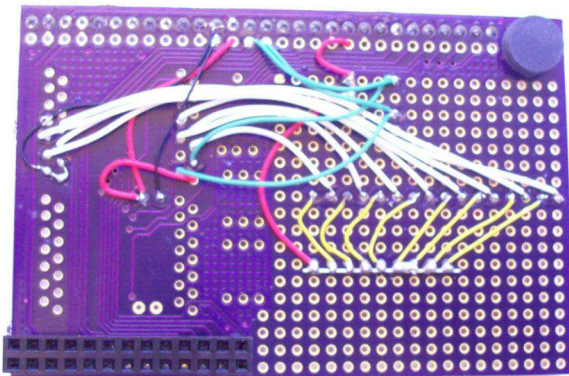
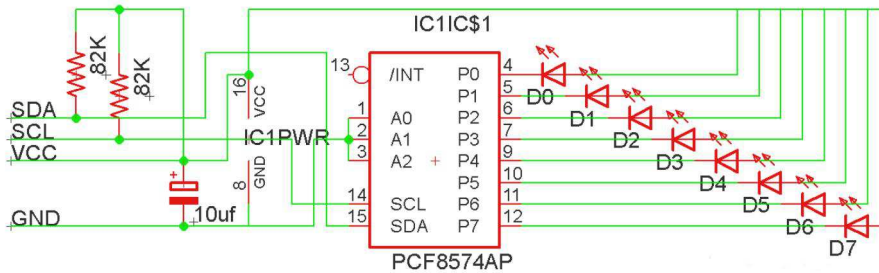

Apparatus assembly

In order to move the LEDs fast enough to see the image, I attached the Raspberry Pi along with the Pi Prototyping board to a long flat wooden stick using screws and spacers. Wood was used to avoid any shorting that may occur. On the back of the stick I attached the SmartUPS to power the Raspberry Pi and make my device more mobile. The SmartUPS is powered by three AA batteries and, though it has several functions, is only used for power in this project. On the other end of the wooden stick I drilled a hole and attached a rod to be used as a handle. This allowed me to easily swing the magic wand around in a circle.

Installing packages

For this program I used the OpenElectrons_LSM303 package installed using

the pip package manager. If you do not have pip you can get it by opening a terminal window and typing:

```
sudo easy_install pip
```

To install the OpenElectrons_LSM303 package type:

```
sudo pip install OpenElectrons_LSM303
```

This command will install the package as well as the OpenElectrons_i2c package needed for I²C functions.

Programming

In order to generate the ASCII characters, I first created a look up table. The table is just a dictionary in which each character is a list containing five hexadecimal values. Each value generates one vertical line of pixels. The example below shows the hexadecimal for the letters B, C and D. A full alphabet, with numbers and symbols can be downloaded in the Python sample programs available from:

<http://www.openelectrons.com/pages/63>

```
#5x7 ascii characters lookup table
lookuptable = {
    ...
    'B' : [0x7f,0x49,0x49,0x49,0x36],
    'C' : [0x3e,0x41,0x41,0x41,0x22],
    'D' : [0x7f,0x41,0x41,0x41,0x3e],
    ...
}
```

With the look up table created, I then started writing the program by importing any needed files and defining my variables. Note that only ACCEL is imported from the OpenElectrons_LSM303 file. Because the LSM303 chip contains a magnetometer, as well as an accelerometer, the library contains two separate classes. Also, notice the 'str' variable. This is the string the magic wand will display.

```
import time
import os, sys
```

```

from OpenElectrons_i2c import
    OpenElectrons_i2c
from OpenElectrons_LSM303 import ACCEL

test = 1
oe = OpenElectrons_i2c(0x38)
lsm = ACCEL()
str = "MagPi Rocks!!!"
length = len(str)
index = 0
test = 1
g = 9.81
t = .05
print str

```

The while loop starts by turning off the LEDs. Next it reads the accelerometer value along the X-axis then quickly reads the value again. With these two values a simplified calculation of acceleration can be performed.

```

while test == 1:
    #turn leds off
    oe.simpleWriteByte(0xff)
    #get first value
    array = lsm.readArray(lsm.ACCEL_X_Y_Z | 0x80, 6)
    aclraw = lsm.accl(array, 0)
    time.sleep(t)
    #get second value
    array = lsm.readArray(lsm.ACCEL_X_Y_Z | 0x80, 6)
    aclraw2 = lsm.accl(array, 0)
    #divide values to compensate for gravity
    #and subtract to find delta
    acl = (aclraw2/g) - (aclraw/g)
    #filter approximate still values
    if acl <= 30 and acl >= -30:
        acl = 0

```

The following if statement and while loop actually light the LEDs. The while loop accesses the look up table for every letter in the string one at time. This allows any message inserted into the 'str' variable to be displayed without any other changes in the program.

```

#if moving from right to left display string
if (acl) > 0:
    time.sleep(.15)
    while index < length:
        for number in lookuptable[str[index]]:
            oe.simpleWriteByte(~number)
            index = index + 1
        #turn off leds for a short time to
        #account for letter spacing

```

```

oe.simpleWriteByte(0xff)
time.sleep(.0015)
#reset string
index = 0

```

A link to the code in its entirety is shown below. Have fun creating images and messages with your own magic wand.

LSM303 Magnetometer

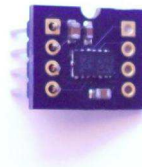

When creating your own magic wand you may come across various issues with certain wand designs. If the wand changes direction at any given time, you will encounter a rapid deceleration. This causes the static and dynamic accelerometer readings to clash, resulting in unwanted input data. If you are a mathematician or are extremely knowledgeable about advance physics concepts, this may be a fun project for you. But for everyone else, you may want to use the LSM303 magnetometer. The code has a few differences, but once you figure out the proper magnetic readings it is very easy. The magnetometer reads the Earth's magnetic field so readings will be different depending on direction and location.

Useful links

OpenElectrons.com full magic wand project kit and program:
<http://www.openelectrons.com/pages/63>

OpenElectrons.com SmartUPS:
<http://www.openelectrons.com/pages/33>

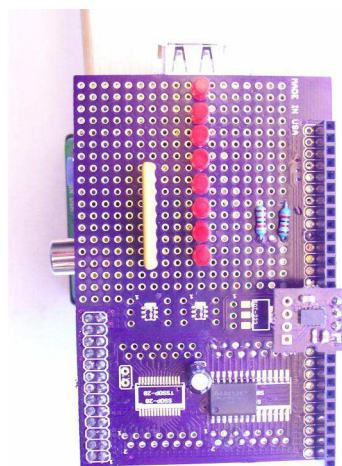

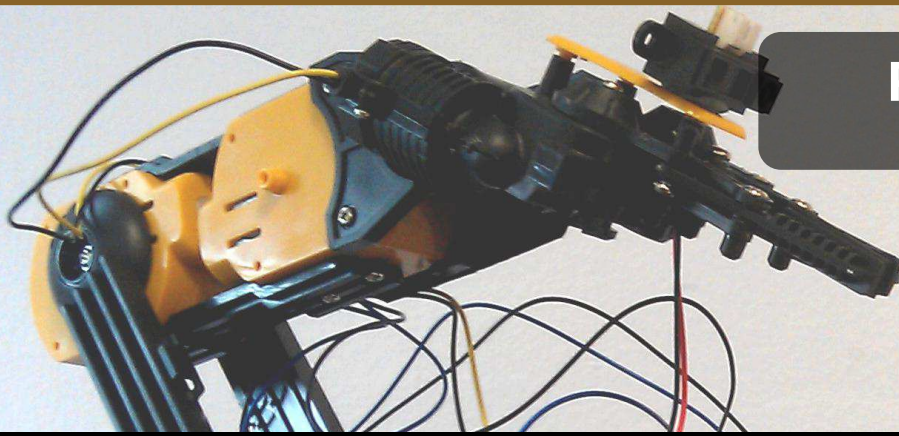

PYTHON CONTROL

Control using a Python script



Peter Lavelle

Guest Writer

Controlling the Maplin/OWIrobot robotic arm

SKILL LEVEL : BEGINNER

Introduction

This article expands on the work by Jamie Scott, et al in the Wikihow article at [http://www.wikihow.com/Use-a-USB-Robotic-Arm-with-a-Raspberry-Pi-\(Maplin\)](http://www.wikihow.com/Use-a-USB-Robotic-Arm-with-a-Raspberry-Pi-(Maplin)) and allows you to control the movement of the arm using a sequence of instructions read from a CSV (Comma Separated Variables) formatted file by a Python script.

This article assumes you are using the Raspbian distribution but you should also be able to get this working using the Occidentalis distribution from Adafruit. (More information about this distribution can be found at <http://learn.adafruit.com/adafruit-raspberry-pi-educational-linux-distro/overview>).

Configuring your Raspberry Pi

Before you can start using the script, there are a few things you will have to do to get your Raspberry Pi ready. The first thing you will need to do is add the user account you are using on the Raspberry Pi to the 'plugdev' group. Assuming you are using the default 'pi' user account, the command to do this will be:

```
sudo usermod -aG plugdev pi
```

The next step is to add a udev rule to allow the 'pi' user to send commands to the arm. To do this, create a file called `/etc/udev/rules.d/85-robotarm.rules` using the command,

```
sudo nano /etc/udev/rules.d/85-robotarm.rules
```

with the contents below:

```
SUBSYSTEM=="usb", ATTRS{idVendor}=="1267",  
ATTRS{idProduct}=="0000", ACTION=="add",  
GROUP="plugdev", MODE="0666"
```

To save the file, press Ctrl-X and then press 'Y' followed by Enter.

You'll then need to install the Python USB libraries. I found that the one from the Apt repository was slightly out of date, so I had to install the Apt version first and then upgrade it using the pip command. The command below will do this:

```
sudo apt-get install python-pip -y  
sudo pip install pyusb --upgrade
```

When the Python USB libraries have been installed, reboot your Raspberry Pi so that the changes to udev and the 'pi' user account take effect with the command:

```
sudo shutdown -r now
```

Connect the arm

When the Raspberry Pi has been rebooted, connect the arm to a free USB port and turn it on. A USB hub should not be needed here. To check that the Pi has successfully detected the arm, execute the command:

```
dmesg | grep usb | grep 1267
```

If the arm has been detected successfully you should see output similar to the line below:

```
[ 252.790554] usb 1-1.3: New USB device  
found, idVendor=1267, idProduct=0000
```

If you don't see the result above, turn off the arm using the power switch, unplug from the USB port, plug the arm back in and turn the power back on.

Getting the code

The scripts can be found on Github at <https://github.com/peterlavelle/maplinarm>

You can clone the repository directly on to your Pi if you have the Git client installed. Installing the Git client on Raspbian is as simple as running the command:

```
sudo apt-get install git-core
```

When you have the Git client installed, run the command,

```
git clone https://github.com/peterlavelle/  
maplinarm
```

to pull down a copy of the Python code. This command will clone the repository into a subdirectory called 'maplinarm' and should pull down the files listed below:

```
git clone https://github.com/peterlavelle/maplinarm  
Cloning into 'maplinarm'...  
remote: Counting objects: 35, done.  
remote: Compressing objects: 100% (23/23), done.  
remote: Total 35 (delta 8), reused 12 (delta 2)  
Unpacking objects: 100% (35/35), done.
```

```
cd maplinarm/  
ls  
commander.py  commands.csv  maplinrobot.py  
README.md
```

Making the scripts executable

Now we need to make the scripts executable by the Raspberry Pi. To do this, change into the directory you cloned the repository down to using the `cd` command and run the command `chmod 755 *.py`. This will give all files ending in '.py' executable permissions. You can double-check this with the command `ls -la *.py` and looking for the 'x' in the left-hand column of the output on each line. See example listing below:

```
-rwxrwxr-x  1 pete pete 1726 May 19 14:11 commander.py  
-rwxrwxr-x  1 pete pete 2388 May 19 14:11 maplinrobot.py
```

Programming the arm

Ok, now on to the good part. The script `commander.py` will read in commands from a CSV file passed to it as an argument.

There is an example file called 'commands.csv' in the Git repository to help you get started. So let's open this file up and take a look with the command:

```
nano commands.csv
```

Contents are included below for reference:

```
shoulder-up,1.00,1.00  
elbow-down,1.00,2.00  
base-clockwise,4.00,1.00  
shoulder-down,1.00,1.00  
grip-close,1.00,1.00  
base-anti-clockwise,4.00,2.00  
grip-open,1.00,1.00  
elbow-up,1.00,2.00
```

As you can see here, the basic format for each command is:

```
command,duration,pause
```

command - any valid command found in the `maplinrobot.py` script

duration - the time in seconds to execute the command for. Make sure all values are entered to two decimal places. e.g, for 1 second specify a value of 1.00 here.

pause - the time in seconds to wait before executing the next command in the sequence. Make sure all values are entered to two decimal places. e.g, for 1 second specify a value of 1.00 here.

The `commander.py` script will execute each line in the CSV file as a separate command for the duration you set and will wait for the number of seconds set in the pause value before moving on to the next command in the sequence.

Valid commands and a description for each can be found below:

base-anti-clockwise - Rotates the base anti-clockwise

base-clockwise - Rotates the base clockwise

shoulder-up - Raises the shoulder

shoulder-down - Lowers the shoulder

elbow-up - Raises the elbow

elbow-down - Lowers the elbow

wrist-up - Raises the wrist

wrist-down - Lowers the wrist

grip-open - Opens the grip

grip-close - Closes the grip

light-on - Turns on the LED in the grip

light-off - Turns the LED in the grip off

stop - Stops all movement of the arm

Try this out yourself by editing the 'commands.csv' file in the repository and replacing the contents with your own instructions to the arm.

Running your program

Running your program is as simple as running the command `./commander.py commands.csv` from the command line on your Raspberry Pi. The script will output each step of your program as it runs. You can find a sample output of my terminal below as an example run using the 'commands.csv' file in the repository:

```
./commander.py commands.csv
Running command 'shoulder-up' for a duration
of 1.000000 second(s) with a pause of 1.000000
second(s)
Sending command shoulder-up
```

The series of commands will then finish with:

```
Done.
```

```
All commands executed. Stopping the arm
```

That's it. If you have any ideas on how this could be improved or expanded (maybe by adding some sort of control logic to the commands file, for example) then feel free to contact me via the contact form on my blog at

<http://solderintheveins.co.uk/contact-me/>

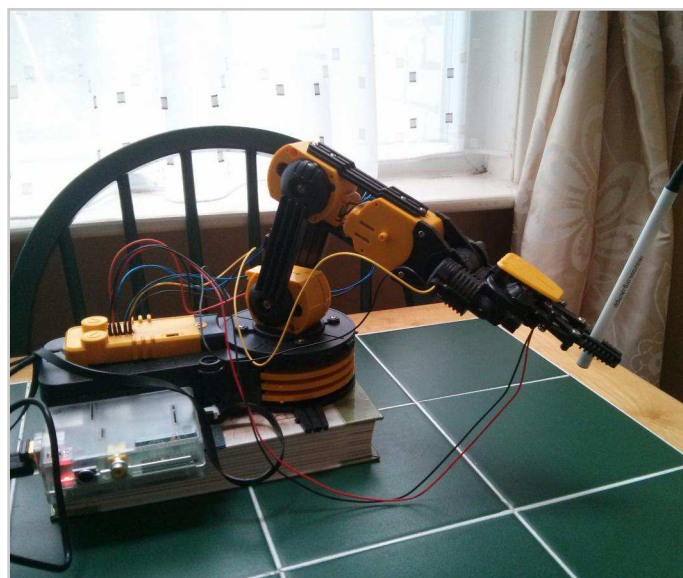

Where to buy?

In the UK the robot arm is available from Maplin (<http://www.maplin.co.uk> - code A37JN) or elsewhere from Robotikits (<http://www.owirobot.com> - codes OWI-535 and 535-USB).

PRINTING WITH CUPS



Stewart Watkiss

Guest Writer

1 - Configuring CUPS

SKILL LEVEL : BEGINNER

This is a two part tutorial on configuring printing on the Raspberry Pi. In this article I am going to explain some of the essentials of setting up printing and adding your printer in Raspbian. This could be useful for printing from your Raspberry Pi or to turn your USB printer into a network enabled printer. Next month we will look at how we can print from the command-line and from within your own Python programs.

The standard method of printing on Linux is with the Common Unix Printing System™ better known as CUPS. Developed by Apple Inc., CUPS is open source software using standards-based printing protocols.

The job of converting an application print request to something that your printer can understand is a memory hungry task. I therefore recommend using a 512MB model B for printing directly from the Raspberry Pi. Even with a 512MB Raspberry Pi you can still run into memory issues. If you have problems with printing then it is worth trying with as few applications running as possible, before looking at other causes.

First we need to install CUPS from the software repositories:

```
sudo apt-get install cups
```

CUPS uses the lpadmin group to determine who is authorised to administer the printers. To add a printer you will need to add your user to the lpadmin group:

```
sudo usermod -a -G lpadmin pi
```

We are now going to use the CUPS web based interface

which is provided by default. All the functionality is built into CUPS, so we do not need to worry about enabling a web server. Just point your browser at <http://127.0.0.1:631> and use your normal username and password when prompted during configuration or when administering the printers. Choose the Administration tab and then Add Printer.

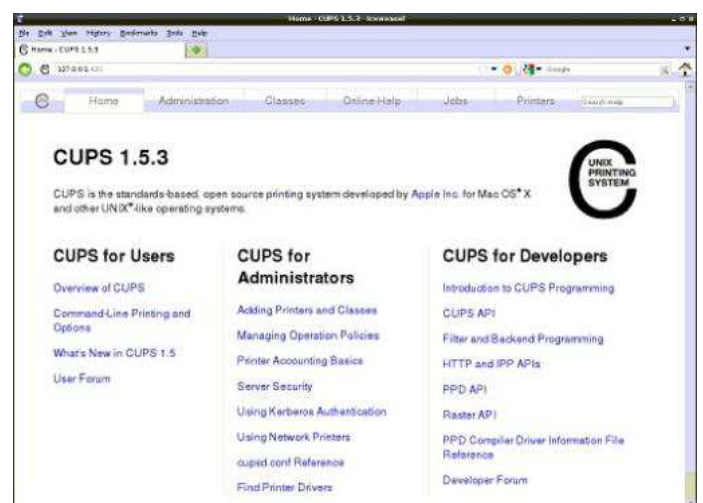

CUPS will search for printers that are physically connected to the Raspberry Pi or that it can see on the local network. In my case it found my network printer "Epson Stylus Photo PX720WD". You will also see some options for HP printers as these are often shown even if there are no HP printers connected.

After selecting the appropriate printer you can customise the name and location of the printers. These can normally be left at their defaults, although you could change the name to one that is easier to remember. If you are likely to be printing from the command line then it can also be useful to make the printer name shorter and avoid any spaces.

An option you may like to enable is “Share this printer” which can be used if you would like to use the Raspberry Pi as a print server for other computers. This will allow you to print to that printer from other computers on the same local network.

The next page will show available printer drivers and attempt to find the closest match. If you have a common printer then there is a good chance of finding an exact match, but if not then it may be possible to select a different printer with similar functionality. Some printer manufacturers do provide Linux drivers that could be installed instead, although it depends upon the manufacturer. If CUPS is not able to find a suitable match you should try the website of your printer manufacturer to see if they have any Linux drivers and follow their instructions.

After selecting an appropriate printer you can choose options for paper size and then the printer drivers will be installed. You can now view the printer through the Printers tab, where you can change any parameters and print a test page. I also suggest selecting the printer as the Server default printer through that page, as that will make it easier to print using the command line tools.

The printer should now be available in any printer enabled applications (e.g. office tools / web browsers) and printing should be similar to that implemented on other operating

systems. If you need any help then online help is included within the CUPS web page:
<http://127.0.0.1:631/help/>

On my Raspberry Pi I have installed AbiWord which is a lightweight word processor that runs well on the Raspberry Pi. You can see the standard print dialog in the screenshot. You can install AbiWord with:

```
sudo apt-get install abiword
```

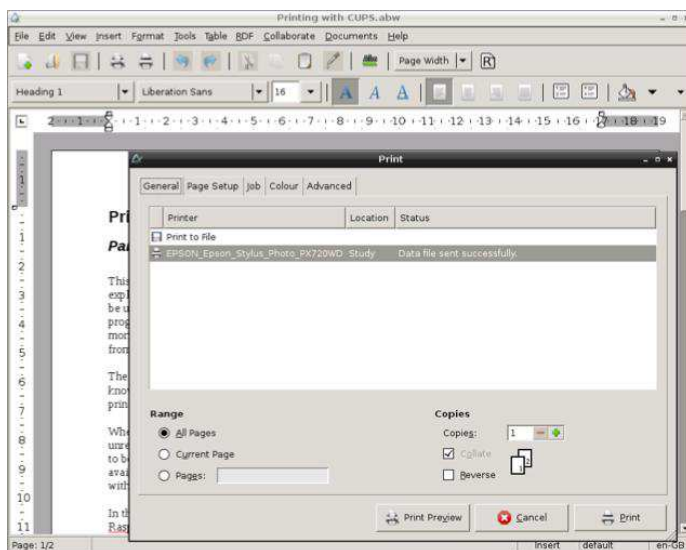

In the next article we will look at printing from the command line and how to print from your own Python applications.

Back In Time

Because most of the content that we publish in The MagPi is educational, it does not age as fast as content in traditional magazines.

To date we have now produced over 1,200 pages of Raspberry Pi goodness and, unless you have had a Raspberry Pi for some time, there is a good chance you do not know about all of the great articles that we have published in previous issues. This special edition represents only 10% of what we have published!

Here is a short list of just some of our earlier articles, with the issue numbers in parenthesis. You can download every issue of The MagPi for FREE from <http://www.themagpi.com> and the Pi Store.

Skutter - build a robot (1, 2, 3, 6, 8, 16)
Play and create computer music (2, 12, 13, 19, 23)
GPIO interfacing for beginners (17, 18, 19, 21, 23, 27)
Command line / Bash (2, 3, 4, 5, 10, 12, 16, 21, 23)
Customise the LXDE menu (4)
Pumpkin Pi - get ready for Halloween (6)
Arduino and Raspberry Pi (7, 8, 15, 16, 17, 28)
Home automation (8, 21)

SD card backup and storage (9, 10, 29)
RISCOS (9, 11, 13, 15)
Operating Systems (12)
BrickPi (17, 18, 23)
Project Curacao (18, 19, 20, 21, 24, 29)
Quadcopter (19, 20)
Environment monitoring (21, 23, 24, 29)
Raspberry Pi oscilloscope (24, 25, 26, 28)
Robotics (25, 26, 28, 29)
Mashberry - monitoring homebrew (26)
Git - mastering version control (27, 28, 29)

There have also been many tutorials for a variety of programming languages.

C (3, 4, 5, 6, 9, 13, 17)
C++ (7, 8, 10, 18, 23, 24, 27)
Python (1, 2, 3, 4, 5, 6, 7, 8, 9, 10, 13, 14, 29)
Scratch programming for kids (1, 3, 4, 5, 13, 17, 29)
Ada (6, 8)
SQL (8, 22)
Charm (10, 11, 14)
Java (14, 16, 25)
FUZE BASIC (25, 26, 27, 28, 29)



Stewart Watkiss

Guest Writer

2 - Printing from Python

SKILL LEVEL : INTERMEDIATE

In the last article we added CUPS printing onto the Raspberry Pi. Now that you have got your printer up and running we can look at how to print from within our own applications. We are going to be using the Python programming language, but we will also take a look at straightforward command line printing which can also be used for printing from other programming languages.

First we will look at printing from the command line. This can be useful within shell scripts or by making a system call within any programming language. The `lp` or `lpr` commands are used for command line printing. The names are an abbreviation of line-printer, although they are seldom used for printing to a true line-printer these days. Both commands work in a similar way but use different options. This is historical from the early days of UNIX. Both `lp` and `lpr` are available on Linux so you can use whichever you prefer.

The command to print a file to the default printer is:

```
lp <filename>
```

You can select a different printer or specify only certain pages using different command line options. You can find details at:

<http://www.cups.org/documentation.php/options.html>

Alternatively look at the help page on your own CUPS configuration page which we used in the previous article.

Unlike the original commands which could only handle text files, the `lp` and `lpr` commands installed through CUPS can handle other formats as well. When you use the commands with a PDF, postscript or image file then CUPS will convert the files using the printer drivers. We will be

using this feature later when we print a PDF file from a Python script.

In some programming languages and GUI toolkits (see box) it is possible to generate printer output using similar instructions to how you generate graphical content for the screen. This is the case in PyGTK, PyQt and WxPython; but while the GTK and Qt toolkits are commonly used with other programming languages they are less used and less well documented on Python. WxPython can be useful if you are using Wx toolkit already. The most common graphical toolkit on Python is Tkinter which has very limited support for printing.

GUI toolkit

A GUI toolkit provides a standard set of buttons, frames and other components to make creating graphical programs easier and with a consistent look and feel. Some include additional printer libraries that make it easy to convert the graphical screen output to a format ready for printing.

Instead of using toolkit support I have chosen to generate a PDF file using `xhtml2pdf` which is sent to the printer using a CUPS library called `PyCups`. This is easy to use and has the advantage that it doesn't need to be used in a graphical environment. Therefore it can be used from within a command line program or a daemon application running in the background.

First we will install some additional packages. The `python-cups` library provides the module that enables Python to communicate with the CUPS printers, `python-pip` will make installing `xhtml2pdf` easier and the `python-dev` libraries are needed to allow `pip` to install some of the libraries used by

xhtml2pdf. Install these using the normal apt-get install:

```
sudo apt-get install python-cups python-pip python-dev
```

Then install xhtml2pdf using pip:

```
sudo pip install xhtml2pdf
```

This last stage will take a while to run as it will download and compile some additional libraries.

You can now use xhtml2pdf on the command line to convert from an HTML page to a PDF file. You could try using a saved web page, but in many cases it will only partially work due to the common use of Javascript (which isn't rendered by xhtml2pdf). Instead I recommend creating the pages using standard HTML markup.

Below is a Python script which will list the available printers and then print to the first printer in the list. This is an example created to show how you can add printing capability to your own program. If you are including this in your own application then you should add additional error checking as well as functionality for the user to select the appropriate printer (if multiple printers are installed).

Line 4 imports the cups library and line 5 the xhtml2pdf library (note that it is imported as pisa which is the former name for the library and is how we will refer to it later).

Lines 11 to 14 generate some basic HTML formatted content. While you could include the usual HTML headers and head section, which you would normally include in an HTML page, I have just added the content of the body section which is sufficient for xhtml2pdf. We then use CreatePDF on line 16 to process the conversion and save the PDF to the file specified in the variable "filename".

I have included a very basic check for PDF errors at this point as invalid HTML could cause this to fail. This is only a generic error message which you may like to improve on in your own programs.

Line 19 is very important! The file needs to be closed so that the write completes and it's possible to read the file back in. Without this then nothing will print and in my case I spent a lot of time tearing my hair out trying to work out what was going wrong.

We create a connection to CUPS and use the getPrinters command to get a list of the available printers. I've deliberately included the print command on line 27 which is the standard Python command to print a line of text to stdout (screen). It is nothing to do with sending anything to the printer, so don't let that confuse you.

Finally on lines 29 and 30 we select the first printer and print the file using the printFile command.

When creating the script you need to create a name that doesn't conflict with any of the names of the library files imported. For instance do not call the script "cups" as that will conflict with the cups library. I used cupsprint.py during my testing.

This has shown one of the ways that you can add printing to your own Python application. This method has been chosen as it's easy to implement and can be used for command line and server applications as well as graphical applications. So over to you... what projects do you have that need to be able to print?

```
1. #!/usr/bin/env python
2. # Print a file to the printer
3.
4. import cups
5. from xhtml2pdf import pisa
6.
7. def main():
8.     # Filename for temp file
9.     filename = "/home/pi/print.pdf"
10.
11.     # generate content
12.     xhtml = "<h1>Test print</h1>\n"
13.     xhtml += "<h2>This is printed from
14.     within a Python application</h2>\n"
15.     xhtml += "<p style=\"color:red;\">
16.     Coloured red using css</p>\n"
17.
18.     pdf = pisa.CreatePDF(xhtml,
19.     file(filename, "w"))
20.     if not pdf.err:
21.         # Close PDF file - otherwise we can't
22.         read it
23.         pdf.dest.close()
24.
25.         # print the file using cups
26.         conn = cups.Connection()
27.         # Get a list of all printers
28.         printers = conn.getPrinters()
29.         for printer in printers:
30.             # Print name of printers to stdout
31.             (screen)
32.             print printer,
33.             printers[printer]["device-uri"]
34.             # get first printer from printer list
35.             printer_name = printers.keys()[0]
36.             conn.printFile(printer_name, filename,
37.             "Python_Status_print", {})
38.         else:
39.             print "Unable to create pdf file"
40.
41. if __name__=="__main__":
42.     main()
```

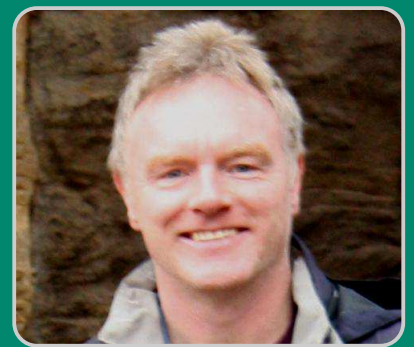

James Hughes

Guest Writer

The Raspberry Pi camera - Part 1

SKILL LEVEL : BEGINNER

The Raspberry Pi Foundation has launched their first peripheral, a 5MP camera. Priced at \$25, the same price as the Model A, it's a very small PCB on which is an Omnivision OV5647 camera module. It connects to either the Model A or Model B Raspberry Pi using a 15cm 15 way ribbon connector.

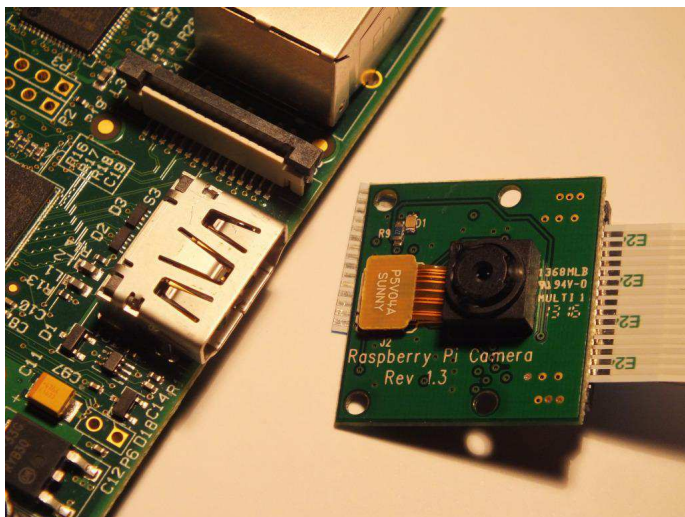

Over the course of this series I will take you through initial connection of the camera to your Raspberry Pi and will show you some of the basic commands used to take both still and video imagery. At the end, some of the more sophisticated features will also be explained. Not every option will be covered (new options are being added all the time so it's difficult to keep up) but hopefully this article will give enough information for you to be able to cover most

image taking tasks. First though, a description of how the camera module came to be...

History

From its first launch the Raspberry Pi has had a connector on it to attach a camera to the GPU (the VideoCore 4 Graphics Processing Unit on the Raspberry Pi). This connection uses the CSI-2 electrical protocol and is a standard used in most mobile phones. It is an extremely fast connection, which on the Raspberry Pi is capable of sending 1080p sized images (1920x1080x10bpp) at 30 frames per second, or lower resolution at even higher frame rates. It had always been intended at some point to release a camera module that could use this connection, as the ability to stream high speed video data through the GPU without any interaction with the ARM processor would always make the camera much more efficient than any USB attached webcam. It would also enable the use of the GPU's ability to encode H264 video or JPEG images in hardware.

It turns out that productising a tiny PCB like the camera board is not a quick task! The prototype was re-designed to remove some unnecessary components, but more importantly, to move the camera crystal, used for timing, to the PCB itself.

Electromagnetic compatibility (EMC) testing had shown that the 25Mhz clock provided by the GPU caused too much interference as it passed up the ribbon cable to the PCB. Adding a crystal to the PCB itself stopped this interference. A couple more board designs later, to help with production line manufacture and testing, and eventually, about a year after the first prototypes, the production board was ready.

Meanwhile, work had been ongoing to write a couple of applications to make use of the camera, to update the GPU firmware to support the camera and to improve the camera tuning as the basic tuning already in place had a number of obvious defects.

Camera tuning is a complex task, which has been covered on the Raspberry Pi website so I won't repeat it here. Suffice it to say, the end results are well worth the extra effort put in by David Plowman while at Broadcom. Thanks David.

So, with the history out of the way, let's take a look at getting your camera going.

Setting up

It's important to start with a warning. Cameras like these are static sensitive. You should earth yourself prior to handling the PCB (a sink tap/faucet or similar should suffice if you don't have an earthing strap).

There are only two connections to make, the ribbon cable needs to be attached to the camera PCB and the Raspberry Pi itself. You need to get it the right way round or the camera will not work. On the camera PCB, the blue backing on the cable should be away from the PCB, and on the Raspberry Pi it should be towards the ethernet connection (or where the ethernet connector would be if you are using a model A).

Although the connectors on the PCB and the Pi are different, they work in a similar way. On the Raspberry Pi you need to pull up the tabs on

each end of the connector.

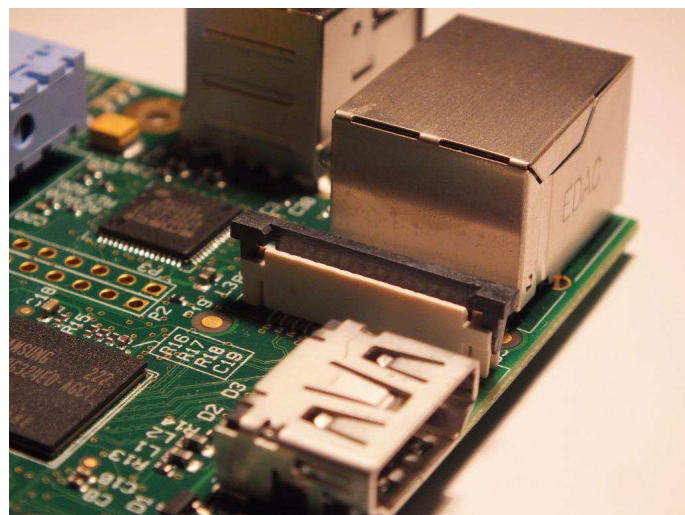

It should slide up easily, and be able to pivot around slightly. Fully insert the ribbon cable into the slot, ensuring it is straight, then gently press down the tabs to clip it into place. The camera PCB itself also requires you to pull the tabs away from the board, gently insert the cable, then push the tabs back.

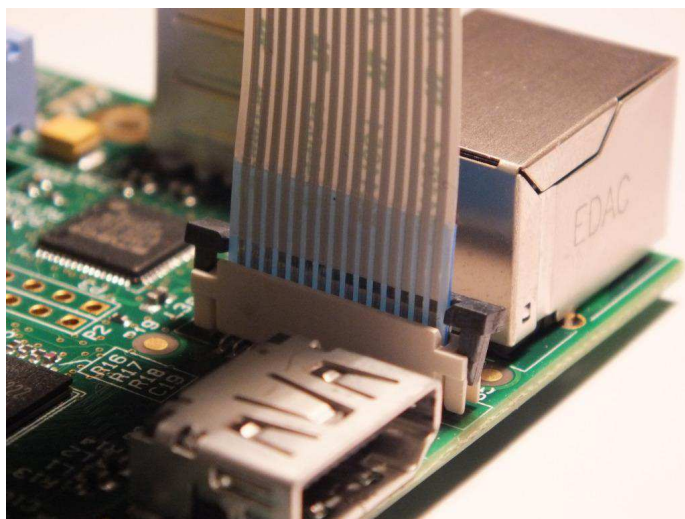

The PCB connector is a little more awkward than the one on the Pi itself. There is a video at <http://youtu.be/GlmeVqHQzsE> which shows the connections being made.

So, we now have the hardware all attached, we now need to make sure we have the correct software installed. As explained above, there are some command line apps to install, and a firmware upgrade with the camera driver and tuning to install. This process may not be necessary in future as newer distro's are

released which already contain the required files.

To update the firmware, libraries and applications, execute the following instructions on the command line:

```
sudo apt-get update
sudo apt-get upgrade
```

Now you need to enable camera support using the `raspi-config` program you will have used when you first set up your Raspberry Pi:

```
sudo raspi-config
```

Use the cursor keys to move to the camera option and select enable. When you exit `raspi-config` it will ask to reboot. The enable option will ensure that on reboot the correct GPU firmware will be running (with the camera driver and tuning), and the GPU memory split is sufficient to allow the camera to acquire enough memory to run correctly. Running a camera and associated encoder does take up a big chunk of memory, as

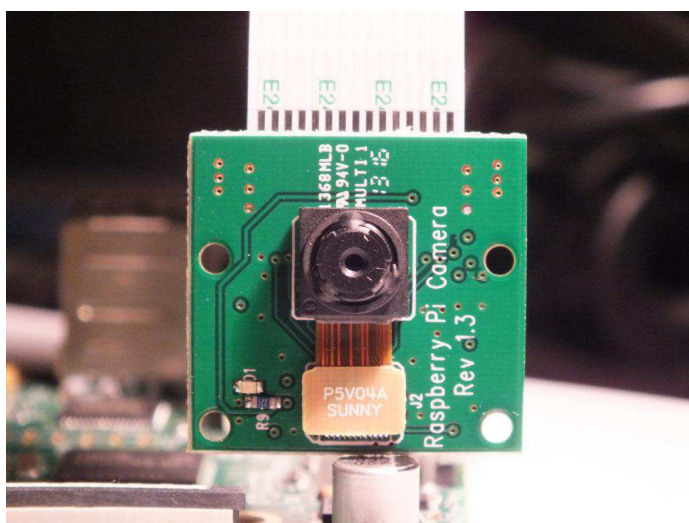

the images are large, and there needs to be at least two of them in memory at any time in order to provide a double (in some cases triple) buffer which prevents 'tearing' of images during display.

Checking it works

OK, we have connected the hardware and installed the software. Now we need to see if it is all working correctly! The quickest way is just to type in:

```
raspistill -t 5000
```

This runs the stills capture program for 5 seconds (or 5000 milliseconds. Note that all times used are in milliseconds). You should see the whole display replaced with a moving image of whatever the camera is looking at. If you don't see the preview appear, or there are error messages displayed, go straight to the Troubleshooting section at the end of this article.

So, what can it do?

As with any camera, it can work in two ways. We can capture still images, just like a camera, or we can capture video, like a camcorder. The two demo applications provided handle these tasks separately. Although it would be quite possible to combine them into one application, that makes the code more complicated and as demo code a lot of effort was put in to make it as easy to understand as possible. As an aside, the C language source code for the applications is publicly available from the Foundation's github repository. Anyone is welcome to play around with it and alter it for their particular purposes. The code is well commented and uses the Doxygen commenting scheme so you can produce HTML documentation directly from the source code.

So, on to the applications themselves. They are command line applications and do not need to be run from a desktop environment since the preview output from the apps is superimposed over the top of any desktop or console being used. Typing just the name of the application, or adding `--help` or `-?` to the command line will produce a list of all the available options. The list is quite long, so you may want to pipe the output into 'less' so you can scroll up and down to read it:

```
raspistill | less
raspivid | less
```

Basic options

Both applications use the `-t` option to specify the length of time in milliseconds they should continue running.

So “`raspistill -t 3000`” will run the camera for 3 seconds.

In the stills case, and if a filename is specified, the capture of the still will take place at the end of the time period. In the video case, and again if a filename is specified, the capture starts straight away and will be as long as the time period.

To specify the filename of the output file, you use the `-o` option. The following command runs the camera for 2 seconds and at the end of the period will take a still image, saving it to the file `image.jpg`:

```
raspistill -o image.jpg -t 2000
```

This command will do the same but will save a 2 second H264 video file called `video.h264`:

```
raspivid -o video.h264 -t 2000
```

You don't need to specify a filename for the output - if you don't then no capture is done, but the preview will still be run for the specified time. If you don't specify a time then 5 seconds is used as a default.

The following will take a picture after 5 seconds:

```
raspistill -o image.jpg
```

So we have made some files, but how do we see what they look like? Well, to view JPG images the FBI program is quite useful. You can install it quickly using:

```
sudo apt-get install fbi
```

Then you can easily display your JPG images, zoom in and out (use `-` and `+`) etc.

```
fbi image.jpg
```

To view video you can use the already installed `omxplayer`.

```
omxplayer video.h264
```

Preview options

You can specify whether you want the preview disabled (`-n`), or whether it is to appear full screen (`-f`) or in a window (`-p`). You can also specify what opacity (`-op`) the preview window is to have (so you can see the desktop underneath if necessary).

To display the preview in a window at position 100,100, width 500, height 400 and at 50% opacity (0-transparent to 255 -opaque), enter:

```
raspistill -p 100,100,500,400 -op 128 -o image.jpg
```

To disable preview completely, enter:

```
raspistill -n -o image.jpg
```

In the next article some of the more advanced features will be discussed!

Troubleshooting

If your camera is not working there are a number of things to check to ensure it is set up correctly.

- 1) Are the ribbon connectors all firmly seated and the right way round?
- 2) Is the camera module connector firmly attached to the camera PCB?
- 3) Have you run `sudo apt-get update`, `sudo apt-get upgrade`?
- 4) Have you run `raspi-config` and enabled the camera?

So, if things are still not working try the following:
Error : raspistill/raspivid not found. This probably means your update/upgrade failed in some way. Try it again.

Error : ENOMEM displayed. Camera is not starting up. Check all connections again.

Error : ENOSPC displayed. Camera is probably running out of GPU memory. Check `config.txt` in the `/boot/` folder. The `gpu_mem` option should be at least 128.

687683768716287362645675
76823587567488165476545678248864829285

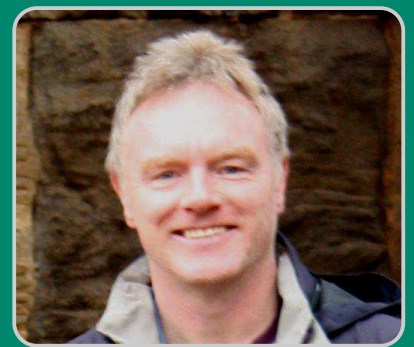

James Hughes

Guest Writer

The Raspberry Pi camera - Part 2

SKILL LEVEL : BEGINNER

Welcome back to part 2 of The MagPi mini series covering the fantastic Raspberry Pi camera module.

In part 1 we covered setting up your camera and its basic operation. In this issue we begin to introduce you to some of the advanced features that the module is capable of, allowing you to capture images like a professional.

the resolution of the resultant captures (either stills or video). But you can also change the quality of the JPG stills using `-q` (`--quality`) and the quality of the H264 encoding using `-b` (`--bitrate`). Both these formats use what is known as lossy compression, that is they throw away detail in order to compress the files. The more detail that is thrown away so the smaller the file. It's simply a tradeoff between quality and file size.

Some examples..

```
raspistill -w 640 -h 480 -q 10 -o smallpic.jpg
```

```
raspivid -w 640 -h 480 -b 500000 -o \
smallvid.h264
```



Prototype camera board (left) and final camera board (right)

Sizing options

Lets begin by looking at sizing options. You can easily specify the size of your captures using the `-w` (`--width`) and `-h` (`--height`) options. These do exactly what you might expect; they change

The bitrate option is measured in bits per second. So in the example above 500000 is 0.5Mbits/s. This is quite a low bitrate for 1080p video but good enough for the small image size requested here. Full HD recording (the default) is supported, which is 1920x1080 at 30 frames per second (abbreviated to 1080p30). This requires a higher bitrate to avoid odd compression artefacts. It is worth trying out various bitrates just to see how it affects the image quality. It is sometimes very surprising how low you can go before the video becomes unwatchable!

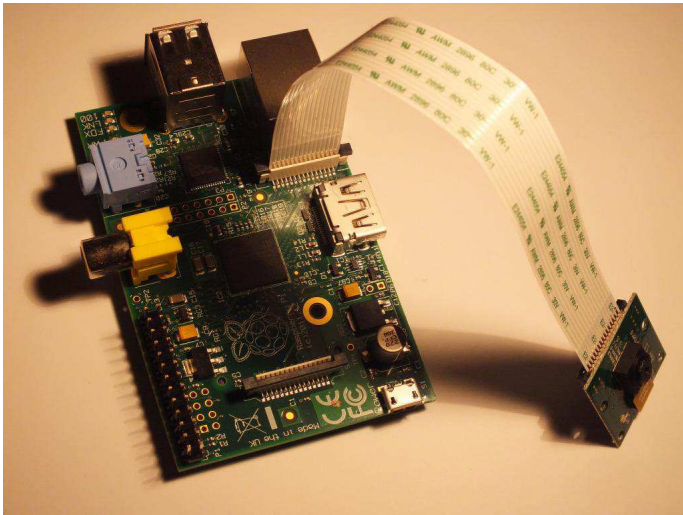

then all your pictures would be saved to the same filename, image.jpg. So you end up with just one picture! By adding a %d in your filename specifier, the image number is added to the filename at the place where the %d is. So our first example above would save a set of files as image1.jpg, image2.jpg... image10.jpg. In fact, the filename is generated using the same formatting as the C language printf statement, so you can do something like this,

```
raspistill -t 50000 -tl 5000 -o image%04d.jpg
```

which specifies the number will be formatted as 4 digits long and use preceding 0's to pad out those 4 digits, resulting in image0001.jpg, image0002.jpg... image0010.jpg being saved. See the printf format specifier documentation (man printf on a console command line) for more information.

Changing image parameters

Just like a compact camera, there are lots of options that can be applied to the images to change their effect, or the way they were taken. The following options are equally applicable to stills or video mode. Also note that some options may not be fully implemented at this stage and you may see no effect when using them. This is because the applications were written to the full Camera API (application programming interface) available, not necessarily what was actually implemented under that API. I'm only going to describe working features here. Feel free to try all the options to see the effect they provide and whether they actually do anything!

First, we have the basic image operations. These are sharpness (-sh [-100 to 100]), contrast (-co [-100 to 100]), brightness (-br [0 to 100]) and saturation (-sa [-100 to 100]). All these settings are commonly found on cameras or even LCD televisions. Try them out with different numbers to see what effect they have - here's a starting point:

```
raspistill -t 5000 -sh 100 -co 50 -br 25 \
-sa 50 -o image.jpg
```

```
raspivid -t 10000 -b 1000000 -o \
highcompression.h264
```

In fact the raspistill application allows us to save in 4 different file formats, although JPG is by far the fastest (and most common). The other formats supported are PNG, GIF and BMP. These are all lossless formats (no data is thrown away in order to decrease file size) and the file sizes are therefore much larger than JPG. They also take longer to save as there is no dedicated hardware acceleration in the GPU for them. You can select the type of file to output using the -e (--encoding) option:

```
raspistill -t 1000 -e png -o image.png
```

Timelapse mode

The raspistill app has a very useful feature called timelapse mode. Instead of just taking one picture, it takes a sequence of pictures at a specified interval (use -tl) until the timeout limit (-t) is reached. So, to take a picture every 5 seconds over a period of 50 seconds, use the following:

```
raspistill -t 50000 -tl 5000 -o image%d.jpg
```

The -t and -tl options are fairly obvious but what is that odd filename specification? Well, if you just specified something like:

```
raspistill -t 50000 -tl 5000 -o image.jpg
```

Image effects (-ifx) are quite fun. These apply interesting filters to the image like negative or emboss. Only one effect can be applied at a time. The full set of effects available are:

negative, solarise, sketch, denoise, emboss, oilpaint, hatch, gpen, pastel, watercolour, film, blur saturation, colourswap, washedout, posterise, colourpoint, colourbalance, cartoon.

```
raspistill -t 5000 -ifx negative -o image.jpg
```

The colour effects option (-colfx) is interesting. Internally, the image is represented using a YUV colour space. YUV represents colour using the luminance Y and blue-luminance and red-luminance differences, UV. The colour effects option allows you to specify the values we are going to use for U and V. This gives us a quick and easy way to do black and white images; we just need to set UV equally to the middle of the range, which is 128. So

```
raspistill -t 5000 --colfx 128:128 \
-o image.jpg
```

Other values for U and V give varying blue and red differences from the middle. Try some numbers!

The final image options I am going to talk about are more about how the picture is taken rather than what processes are applied to the image. These are metering mode (-mm) and automatic white balance mode (-awb).

Metering mode specifies what area of the incoming image is used for determining the brightness of the image. Internally, there is a target brightness that is required and the camera system adjusts the internal gain to hit that target. But to do that it needs to know what brightness the incoming image is so it can be boosted to the required level. The area of the image that is used to determine that incoming brightness is what is defined by the metering mode. There are two usefully distinct options: average and spot. Spot takes the very centre of the image and uses that while average uses the

whole image. So if you have a scene with a very bright point in the centre, using spot will almost certainly underexpose. In that case you should use average:

```
raspistill -t 5000 -mm average -o image.jpg
```

AWB stands for automatic white balance. This is a complicated subject, but in very simple terms it is the adjustment made to the image to compensate for different lighting conditions to make whites look white. For example, different types of office light produce different lighting

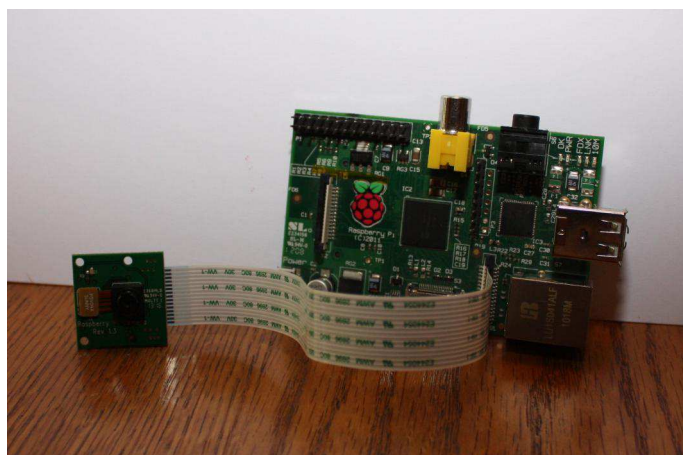

conditions and the system needs to compensate for those conditions so the white walls still look white in the photograph. By default the AWB selection is done automatically using Bayesian analysis of the scene to make an educated guess on the lighting conditions. However, you can specify the AWB approach being used depending on the scene being captured. The options are :

auto, sun, cloud, shade, tungsten, fluorescent, incandescent, flash, horizon.

So to set up the AWB for a room lit by tungsten filament bulbs you would use:

```
raspistill -t 5000 -awb tungsten -o image.jpg
```

Anything else?

We've covered many of the features available on the Raspberry Pi camera, but the best way to

find out about them is to play with the camera, adjust settings and see what happens. To help with this there is a demo mode available which runs through a lot of the options automatically. The following example runs for 1 minute, changing an effect every 500ms (½ second)

```
raspistill -d 500 -t 60000
```

One option not mentioned is the ability to output the image or video stream to stdout, so it can be piped to other applications (for example, network streaming). To do this, instead of specifying a filename for the -o option, you use the - (hyphen). The following example outputs the jpg data to stdout, where it is passed on to the file image.jpg. The effect is the same as specifying -o image.jpg.

```
raspistill -o - > image.jpg
```

Final words

As with everything Raspberry Pi, the camera is meant to be a learning experience. Many options are available for you to try out, some might be useful, some not so useful. Try them out, experiment, you cannot break it using any of the options!

The source code for the applications is publicly available and was written in a very straightforward fashion using C. There are lots of comments to make it easier for people to modify it to their own purposes.

Feel free to pile in, change stuff, see what it does. If you add a great new feature, make sure you post about it on the Raspberry Pi forums - you never know, it might make it into the official applications!

The MagPi print edition

Experience hundreds of pages of Raspberry Pi hardware projects, software tutorials, reviews of the latest expansion boards and interviews with the makers and creators involved.

Originally funded through Kickstarter, The MagPi printed bundles of Volumes 1, 2 and 3 bring all the information of this peer-reviewed magazine within arms reach.

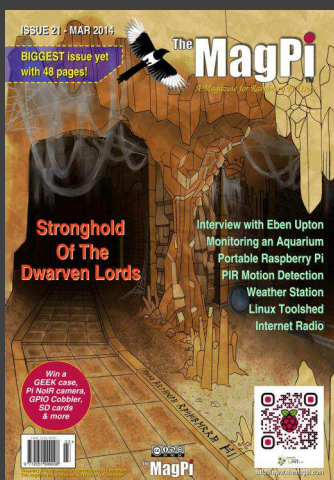

Volume 1: Issues 1 - 8
Volume 2: Issues 9 - 19
Volume 3: Issues 20 - 29

Available worldwide from these resellers:

swag.raspberrypi.org
www.modmypi.com
www.pi-supply.com
thepihut.com
www.adafruit.com (USA)
www.buyraspberrypi.com.au (Australia)



The MagPi is also available on special offer to schools for a limited time only:
www.themagpi.com/education



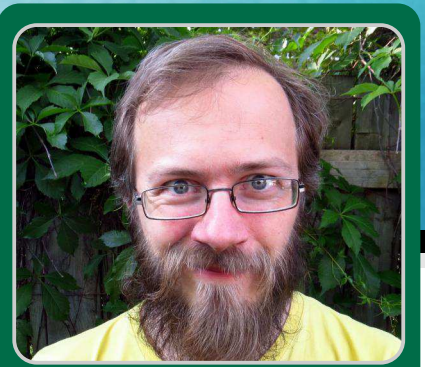
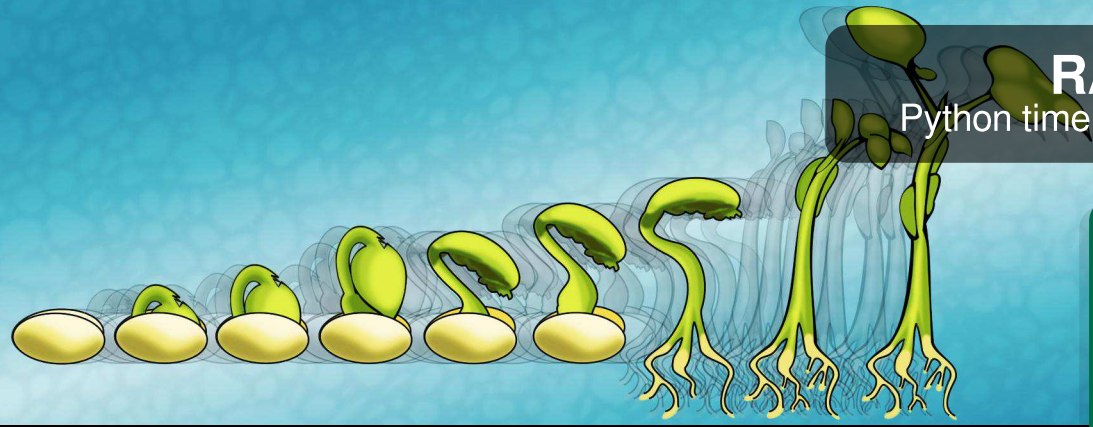

Tom Denton

Guest Writer

Create a time-lapse video with the Raspberry Pi camera

SKILL LEVEL : ADVANCED

On December 27th, 2013, a pair of Raspberry Pis with Raspberry Pi cameras were placed in a cottage in Ontario overlooking Georgian Bay. About four months later, they were found to have performed wonderfully, capturing over 40,000 photos at two minute increments. Although the shoot was planned for a few months, it was not expected to be as successful as it was. When the cameras were setup, the windows were quite frosted over. Therefore, the expected outcome was to see the back of an icy window. However, the windows stayed clear during the entire winter. The photographs taken captured ice forming and dissolving on the lake, deer passing like ghosts, magnificent storms and amazing sunrises. The images were compiled together to form the resulting time-lapse video given at:

<http://inventingsituations.net/winter-on-georgian-bay>

In this article, there are some code snippets that can be used to make a time-lapse video using Python and command line tools. In particular, the `raspistill` program is used to capture the images and the Python Image Library (PIL) and `mencoder` are used to create the final movie.

Setting up Raspberry Pi and camera

Follow <http://www.raspberrypi.org/help/camera-module-setup/> to connect a Raspberry Pi camera to a

Raspberry Pi. Then install the latest Raspbian image and type:

```
sudo raspi-config
```

Select:

```
expand the filesystem
enable camera
advanced option
memory split (minimum 128 for gpu)
enable boot to desktop/scratch
Console
finish
reboot
yes
```

This will enable the camera, use all of the SD card for the Linux installation, turn off the boot to X and allow the ARM processor to use the maximum amount of memory. Next, make sure that Raspbian is up to date and install the libraries and programs needed for this project:

```
sudo apt-get update
sudo apt-get upgrade -y
sudo apt-get install -y python-imaging \
python-zmq python-matplotlib mencoder \
imagemagick
sudo reboot
```

Taking photos with raspistill

The easiest way to use the Raspberry Pi camera is via the `raspistill` command. It has a time-lapse option, which many people have used to good effect. For an extremely long time lapse, finer control over the images taken proved to be better than the automatic settings. As a result, a Python script was written to take photographs at regular intervals. Calculations were used to make sure that the images were of consistent quality. Image quality consistency was maintained by the manipulation of shutter speed, ISO and post capture alteration.

The two options that control the brightness of an image are the shutter speed and the ISO (International Standards Organization) setting. The shutter speed controls how long the camera collects light to create an image, where a longer shutter speed will create brighter images but will be more likely to have motion blur if there is movement in the frame. On the Raspberry Pi, the slowest shutter speed available is about 2.5 seconds; longer speeds will cause the camera to hang and not take pictures until the Raspberry Pi is rebooted. To be safe, the maximum shutter speed was set to two seconds. Shutter speeds in `raspistill` are measured in microseconds. Therefore, a shutter speed of 1000000 implies one second.

The ISO setting controls the sensitivity of the sensor, within a range of 100 (low sensitivity) to 800 (high sensitivity). When the ISO setting is high, brighter images are taken, but they will also tend to be much more noisy.

The command `raspistill` can be used to take a photograph with a set shutter speed and ISO setting. The automatic settings should be avoided, apart from AWB (auto white balancing):

```
raspistill -awb auto -n -t 10 -ss 1000000 \  
-ISO 100 -o mypic.jpg
```

Python can be used to run `raspistill` by using a subprocess call:

```
import subprocess  
ss=1000000  
iso=100  
command='raspistill -n -t 10 '  
command+='-ss '+str(ss)  
command+=' -ISO '+str(iso)+' -o mypic.jpg'  
subprocess.call(command , shell=True)
```

The goal for the project was to keep images at about the same brightness over the course of a day. The brightness of each image was measured. Then the shutter speed and ISO setting were adjusted. Since fast movements are not important for time lapse pictures, the ISO was kept at 100 as much as possible to ensure high quality images.

Calculating the average brightness

The Python Imaging Library (PIL) is great for manipulating images in Python:

```
import Image  
im=Image.open('mypic.jpg')  
pixels=(im.size[0]*im.size[1])  
hist=im.convert('L').histogram()  
br=float(sum([i*hist[i] for i in  
range(256)]))/pixels  
print br
```

This example opens an image and uses the image's histogram to compute the average brightness of the image. For a greyscale image, there are 256 possible pixel values. The histogram counts how many pixels there are for each value. The average brightness of the images is calculated by adding up all of the pixel brightness values and dividing by the number of pixels.

Adjusting the shutter speed

To retain the same image brightness, as the light increases or decreases, either the shutter speed or the ISO setting should be adjusted. The brightness from the previous image can be used to adjust the shutter speed,

```
delta=128-br
```

```
ss=ss*(1 + delta/128)
```

where 128 is the target brightness and `ss` is the shutter speed in the previous Python example. To reduce flicker in the time lapse video, the average brightness from the last ten or twenty images was used.

Since the camera used had an infrared filter and the light level was low during the night, a brightness threshold was used to avoid storing images in very dark conditions.

Installing the scripts

To install the scripts, type:

```
git clone https://github.com/sdenton4/pipic
cd pipic
chmod 755 timelapse.py
chmod 755 deflicker.py
```

The time lapse program can be run with the default settings,

```
./timelapse.py
```

or the available options can be listed:

```
./timelapse.py -h
```

When the time lapse program runs, it writes the pictures into the `~/pictures` directory.

To start the time lapse program when the Raspberry Pi boots type,

```
sudo nano /etc/crontab
```

and add,

```
@reboot pi python /home/pi/timelapse.py
```

Then save the file and exit nano.

Making the movie file

After running the time lapse program for a long time, the photographs should be assembled into a movie.

This can be done very easily with `mencoder`:

```
mencoder "mf://*.jpg" -mf fps=18:type=jpg \
-ovc lavc -lavcopts \
vcodec=mpeg4:mbd=2:trell:vbitrate=3000 \
-vf scale=512:384 -oac copy -o movie.avi
```

This command uses all of the `.jpg` files in the present working directory and assembles them into a movie. A sound track can be added to the movie, using an existing audio file:

```
mencoder -ovc copy -audiofile MYMUSIC.mp3 \
-oac copy movie.avi -o movieWithMusic.avi
```

Post-processing

The movie can look a bit too grey. To create more contrast, PIL's image manipulation capabilities can be used. The greyscale histogram of a single image can be plotted using Python and `matplotlib`:

```
import Image
from matplotlib import pyplot as plt
im=Image.open('mypic.jpg')
hist=im.convert('L').histogram()
plt.plot(hist)
plt.savefig('myhist.png')
```

The `matplotlib` package can also be used to plot the histograms of many images at once:

```
import Image,glob
import numpy as np
from matplotlib import pyplot as plt
M=[]
for x in glob.glob('*.jpg'):
    im = Image.open(x)
    M += [im.convert('L').histogram()]
plt.pcolormesh(np.array(M))
plt.savefig('mymanyhist.png')
```

This example reads all of the `.jpg` files in the present working directory. In the resulting image each horizontal line of pixels is one image in the time lapse. The brightness of a pixel indicates how many pixels in the original image have a given intensity.

Some of the images captured were slightly grey. This implies that there is not very much contrast, because

most of the pixel values are clustered in the middle of the histogram. In these cases, there were no completely black pixels and only a few completely white pixels. The image at the bottom left of this page illustrates an example grey image.

To improve the balance, the image histogram can be used and stretched out to fill the whole range (from 0 to 255). The first step is to find the bounds a and b ,

```
pixels=im.size[0]*im.size[1]
a=0
count=0
while count<0.03*pixels:
    count+=hist[a]
    a+=1
b=255
count=0
while count<0.05*pixels:
    count+=hist[b]
    b-=1
```

where a and b are defined such that 97% of the pixels are brighter than a and 97% are darker than b . Now a and b can be used to stretch the histogram,

```
im3=Image.eval(im2, lambda x: (x-a)*255/(b-a))
```

where the `eval` function applies the function given within the parentheses to each pixel in the image and `Lambda` is an easy way to make a simple function.

For example, the following code snippet prints 12.

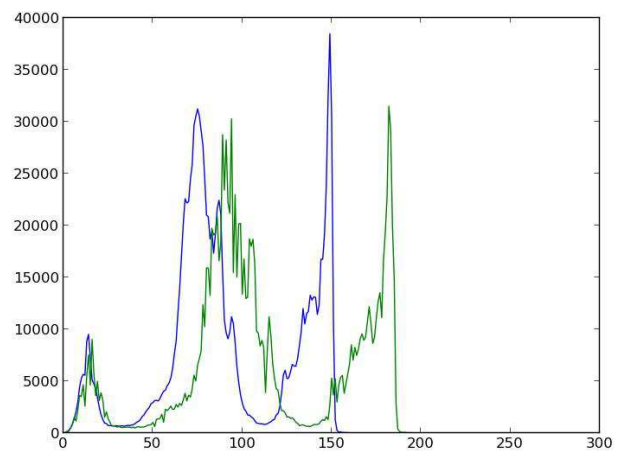

```
f=lambda x: x*3
print f(4)
```

The histograms above are for the original (green) and levelled image (blue). The histogram for the levelled image is quite spread out. It is also very jagged, because the stretching removes many possible pixel values. Fortunately, this is not very visible in the levelled image. In practice, the bounds ' a ' and ' b ' were based on a rolling average from nearby pictures, such that there were no dramatic changes. The final levelled image is shown at the bottom right of this page.

The techniques discussed in this section can be found in the `deflicker.py` script. Type,

```
./deflicker.py -h
```

for a list of available options. The script reads images that are in the present working directory.



Before

After



PI VISION A GUI for the Raspberry Pi camera

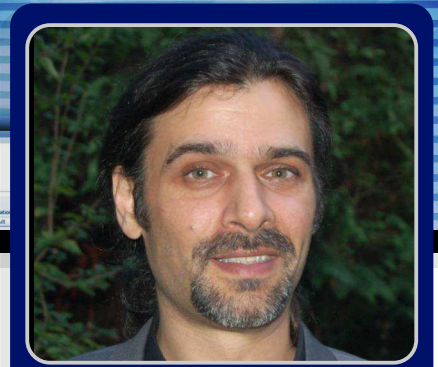

B. J. Rao

Guest Writer

Easily explore all the features of the Raspberry Pi camera

SKILL LEVEL : BEGINNER

Pi Vision is a graphical user interface (GUI) for the recently introduced Raspberry Pi camera. It allows you to control the camera's functions via its command-line applications. It also displays the commands sent. The project was written in Pascal and developed using Lazarus - a professional, free Pascal integrated development environment (IDE). It has been released as open source. Pi Vision makes it easy to control the camera plus it is also instructional and fun!

Building block

If I had to name one of the most interesting and inspiring gadgets to come out in recent years it would probably be the little Raspberry Pi. Its low cost, small foot print and the fact that it runs Linux makes it an obvious choice for all sorts of projects; a building block that sparks the imagination to do just about anything.

However, the idea that makes the Raspberry Pi so unique is that it was designed and introduced as an educational tool; something to familiarize ourselves with actual computing. Not just at a user level but at the programming and integration level as well. The recently introduced Raspberry Pi camera aligns itself with that same idea.

You probably have an i-something, a tablet device or

a smart phone and you likely work and play on a Windows, Mac or even a Linux machine. But the Raspberry Pi, in all its minimalism, maximizes on the means to allow people to get started with actual computing. So much so that the Raspberry Pi is becoming a form of expression - a means of allowing so many of us to transform our imagination into a more tangible and functional form.

Native camera

Like any camera the Raspberry Pi camera has a wide spectrum of uses. It also allows many parameters to be set. But it is important to mention that the Raspberry Pi camera is not like a typical webcam.

What's the difference? Well, like the Raspberry Pi it is an educational tool. The idea is to get started with the workings and functions of a digital camera - to learn what impact each setting has to the final image. What's more, its 5MP sensor takes great HD pictures and video.

The camera is operated through terminal commands. You send commands to control it via the command prompt. The two commands to control the camera are `raspistill` and `raspivid`. Enter each command without any parameters to see its help. Please read pages 104 to 111 for more details about these commands.

Using the command-line provides an understanding of how the camera is controlled. It allows you to configure commands in almost any combination you want. It also invites you to take the next step and create your own interface for it.

Capturing the interest

Most young kids, like my kids, love playing video games. Games are typically the first type of interaction with computers. But many will reach a point where they don't just want to "play" games - they also want to "make" them as well. At the very least they want to understand more about what goes on 'behind the screen'. But finding an entry point to basic computing is easier said than done.

Fortunately, the Raspberry Pi's camera is proving to be that entry point. It not only captures their interests but also seems to be maintaining it. My kids can now type in commands that do something simple but rewarding and which provide immediate visual feedback. The trick here is to get the kids to take pictures of themselves - usually while pulling funny faces. It is enough for them to type in another command and make another picture.

Pi Vision

Where does Pi Vision fit into all this? Pi Vision is a simple, open source application which attempts to leverage the entry point. The incentive of Pi Vision is to allow for easy use of the Raspberry Pi camera while also serving as an instructional tool.



Each time a picture or video is captured with Pi Vision it shows you what commands are sent to the

Raspberry Pi to control and operate the camera. This assists novice users in understanding the command structure. What's more, since Pi Vision is open source you can review and copy the code plus make changes to suit your needs and interests.

In the next section of this article you will find more details about the Pi Vision open source project. For now, assuming that you already have your Raspberry Pi camera setup and running, lets install Pi Vision.

Pi Vision runs on the Raspbian OS. Start the LXDE GUI with the terminal command `startx`. Download the Pi Vision software from <http://heywhatsthebigidea.net/?download=1021>. Right-click on the downloaded file and choose "Xarchiver". Click on the "Extract files" icon and check the option "Extract files with full path". This will create a new directory called `PiVision_RPi`.

Important! In order to run the Pi Vision application you need to first set permissions. Open the `PiVision_RPi` directory and right-click on the file `rpiCC` - the Pi Vision application. Select Properties and from the File Properties dialog select the Permissions tab. There is a small check-box which needs to be checked called "Make this file executable".

Double-click on the Pi Vision application. The start-up page of Pi Vision includes a button called "Test Camera Preview". This will start a 5 second 640 x 480 (VGA) camera preview in the upper left corner of your screen. Assuming that your camera is set up correctly and the preview is successful then you are now ready to start using your camera with Pi Vision.

You will notice that Pi Vision will display the commands sent in a text area in the upper region of the application. Go ahead and experiment with different settings in the Photo, Video and Settings sections to see the results. Later you can try sending the command instructions yourself. To do this take a photo or video and then select and copy the `raspistill` or `raspidvid` command in the text area. Open a terminal window by selecting the "Terminal" button at the lower right region of the application. Open the "Edit" menu and choose "Paste".

Open source

The language of choice for the Raspberry Pi is Python, and with good reason. Python offers simplicity, it is easy to understand and very easy to use. It subscribes to the novice developer, in particular, very well.

Other ways to create programs/applications are also available, but when it comes to Rapid Application Development (RAD) you will need something more advanced. For me the choice was Pascal - more specifically the Free Pascal Compiler (FPC) with the Lazarus IDE.

The Lazarus IDE is an open source development environment to aid writing applications using the Pascal language. It is very powerful and includes just about everything necessary to make really great applications very easily and with minimal effort.

Pascal is not the best language. There is no such thing as "best". The question is what does it take to satisfy the requirements and do it in a good, easy and effective way?

Pascal is a strongly typed language and offers important structured programming techniques. It was the teaching language of choice during the 80s and early 90s. Additionally, the Lazarus IDE and the FPC run on most systems; Windows, OSX, Linux and of course Raspbian. That means you can write code and develop applications for the Raspberry Pi using a powerful IDE which compiles to almost all platforms.

Not surprisingly, Pi Vision was written in Pascal using the Lazarus IDE. In fact the Lazarus IDE is part of the Raspbian OS repository. You can download and install it directly. But should you choose to do so please note that it will consume 0.5GB of storage space on your SD card.

First install Pascal by entering:

```
sudo apt-get install fpc
```

Then install Lazarus by entering:

```
sudo apt-get install lazarus
```

This can take some time to download and install. After it has completed you will find Lazarus in the "Programming" section of your LXDE application menu.

The Pi Vision project itself can be downloaded and then opened and built using Lazarus. Pi Vision is hosted on Github. Simply download the entire project, unpack it and open it using Lazarus. Full instructions can also be found inside the project.

It should be of interest to note that since you can also install Lazarus on many other operating systems such as Windows or Mac, you can open the Pi Vision project and run it on those systems as well. Obviously this would be only for review.

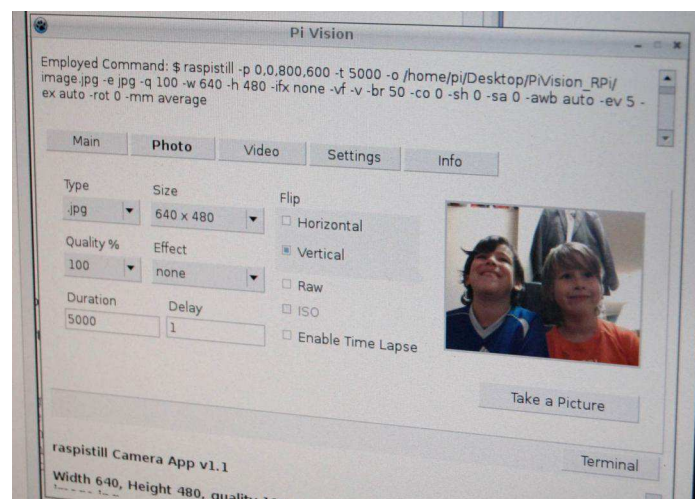

Links

Pi Vision

<http://heywhatsthebigidea.net/projects/pi-vision-a-raspberry-pi-camera-controller/>

Pi Vision Project Github Repository

<https://github.com/local-vision/Pi-Vision>

Lazarus Free Pascal Compiler

<http://www.lazarus.freepascal.org/>

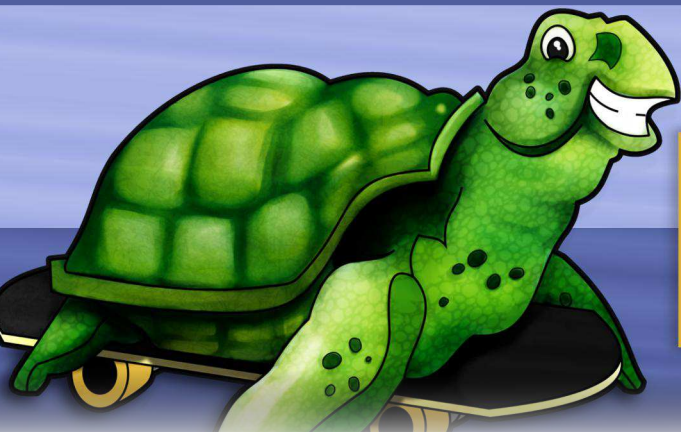

```
1 algo.go (100);  
2 algo.turnRight (90);  
3 algo.go (100);
```

ALGOID

Programming made simple and fun



Yann Caron

Guest Writer

Learning to program video games

SKILL LEVEL : BEGINNER

Two years ago my 10 year old son asked me, "Daddy, what is your job?". I replied that I write computer programs which give the computer some tasks. I didn't have to wait long for the second question. "Ok, but how do you tell the computer what it has to do? How does a program work?".

That was when I decided to write Algoïd to teach him what computer programming is and how to do it. Originally Algoïd was designed to run on the Android platform but recently I discovered the Raspberry Pi; this low cost, credit card sized computer exactly designed for education.

What is AlgoIDE? AlgoIDE is a combination of an integrated development environment (IDE) and its own language (AL) designed together to simplify the understanding of programming!

Principles

The AL language was developed with three ideas in mind:

1) Its apprenticeship should be as progressive and memorisable as possible.

Try to explain to a kid how the "for" loop works. You will discover you need to explain variables, conditions, boolean expressions and incrementation... all just to explain a simple loop!

Algoïd's syntax was designed to be as easy to memorise as possible. All its structure statements are written the same way (variables, functions, arrays, objects ...)

2) Its syntax should be as close as possible to industry standards.

Learning a language represents a large amount of time so the day the kid wants to use Java, Python or C++ they will not have to learn again unfamiliar syntax and another nuances.

3) Its semantic should not be limited to one or two paradigms.

When I was young I was very frustrated by the BASIC language. After having understood how imperative statements and procedures work, I was limited to them. To progress I had to learn another language and another syntax.

All things considered, AlgoIDE tries to simplify programming and its understanding. My first idea was to create a step by step execution mode. With two clicks the execution slows down and highlights appear in the source code on the line being executed. This is possible with the debugging mode. We will see later how it works. AlgoIDE also has the ability to view the variables in use on its scope viewer and has its own logger.

AlgoId quick tour

It is recommended to download the Java version of AlgoId from <http://download.algoId.net>. AlgoIDE is also available on the Pi Store at <http://store.raspberrypi.com/projects/algoId>. It is also available on the Google Play store at <https://play.google.com/store/apps/details?id=fr.cyann.algoId>.

Install it on your Raspberry Pi and launch it from the Desktop. From the Examples menu, choose `demo.al`. Click on the "Play" button and the demo script will run.

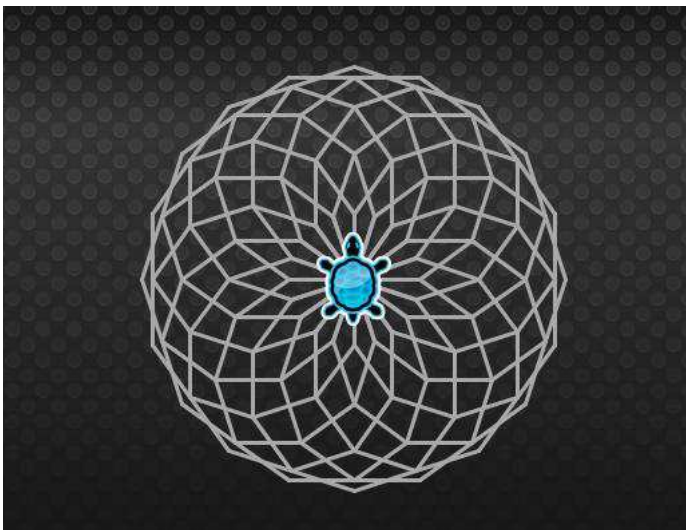

The program contains a function named `poly` and a loop that draws a rose window. Note that the function declaration is really special:

```
set poly = function (size, n) {  
  } ;
```

In AL everything is an expression. Example declarations are:

```
set size = 7;  
set o = object () {  
  } ;
```

In AlgoIDE, check the "Step by step" box and click the "Play" button again. Now you can understand where the program is at and what it is doing. The number at the right of the check box allows you to change the step by step speed.

Now uncheck step by step mode and check the "Debug mode" box. Click on the number 12 in the

source code margin. This will add a new breakpoint. Click on the "Play" button to run the program.

Three new buttons appear - run to the next breakpoint, run to the next line and run to the next token. The AlgoId debugger considers each token as an object path and expression calculation. This is perfect to understand the precedence order for example. Try each of the three new buttons.

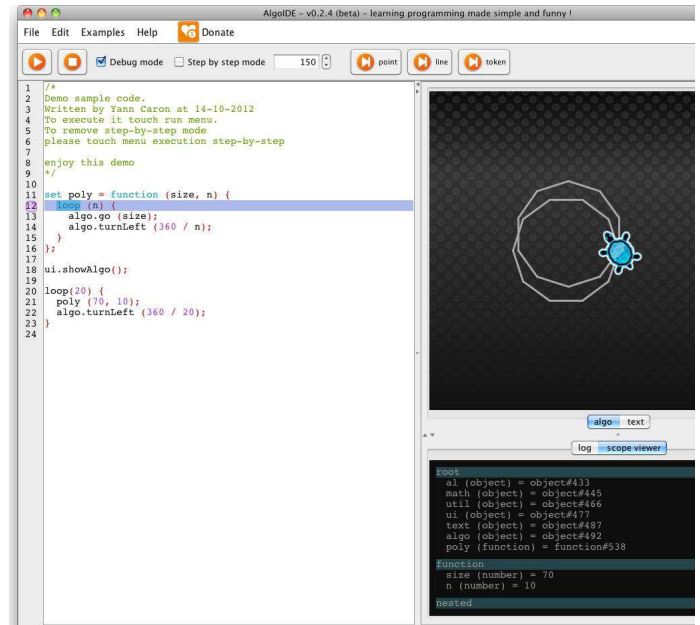

You can observe the current variables and their values in the Scope Viewer window. For example debug the binary tree program (Examples > fractal > binary tree.al) and set a breakpoint on line 12. Observe the value of `it` and `size` in the Scope Viewer with each iteration.

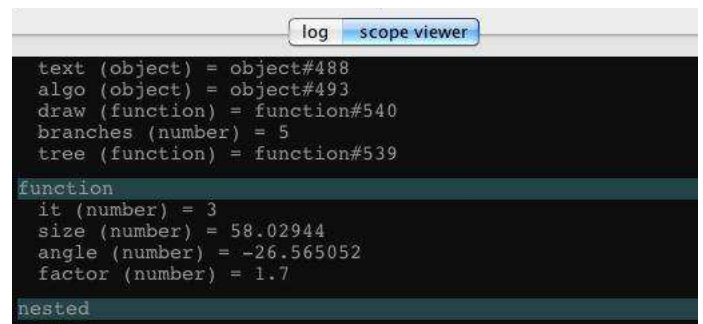

Documentation

To learn a language and how to program, the most important thing is documentation and sharing experiences. The <http://www.algoId.net> web site contains a complete language reference section and a continuously updated tutorial list. The tutorials

contain a lot of examples and progressive exercises to help explain each language statement and function.

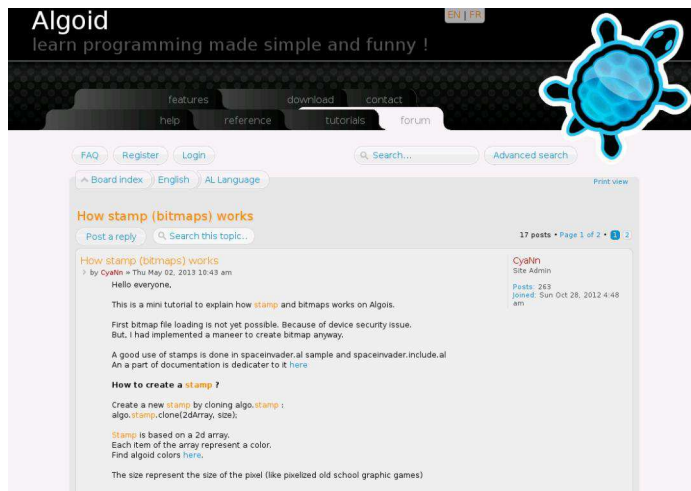

Algoird is also a community federated by the forum <http://forum.algoird.net>. It contains a lot of discussions, problem solutions and mini-tutorials.

Another way to learn programming is with other people! Some members have created a team to develop games on Algoird. When programs are interesting they are included in the next application release. Everyone can learn from one another. Everything in the Algoird environment is based on sharing source code and knowledge.

Teaching

Triangle Spiral

What are the modifications to do into code to obtain this following figure:

Solution:

```

1 // spiral
2 for (set i=0; i<450; i=i+10) {
3     algo.go (i);
4     algo.turnLeft (121);
5 }

```

Algoird is also designed for teachers. As Algoird is a free tool, all help is greatly appreciated for tutorial writing, documentation corrections, etc.

Algoird gives teachers the ability to write their own learning plugins. A tutorial and an article explaining how to do that is already available. Writing a plugin in Algoird is very simple. The teacher just needs to have some basic Java and Swing development knowledge.

Plugin development is divided in two steps:

- 1) Develop the library with objects and functions needed for the course.
- 2) If necessary, develop a new Java panel (view) and bind it with the library.

A complete range of tools are available to interact with the AL language. The tutorial provides a complete Java NetBeans project starter and documentation.

This is an example of the library development:

```

// show panel method
PluginUtils.addMethod(my, "show", new PluginUtils.Behaviour() {
    @Override
    public void visite(Block<RuntimeContext> t, RuntimeContext c) {
        appContext.getIDPanel().showPanel(myPanel.getName());
    }
});

// setter method
PluginUtils.addMethod(my, "setText", new PluginUtils.Behaviour() {
    @Override
    public void visite(Block<RuntimeContext> t, RuntimeContext c) {
        String text = PluginUtils.getParam(t, 0).getString(); // get the text param
        myPanel.setFieldText(text);
    }
}, "text");

// event method
PluginUtils.addMethod(my, "onClick", new PluginUtils.Behaviour() {
    @Override
    public void visite(Block<RuntimeContext> t, final RuntimeContext c) {
        final FunctionInstance f = PluginUtils.getParam(t, 0).getFunction(); // get
        // register to button action listener
        myPanel.addButtonActionListener(new ActionListener() {
            @Override
            public void actionPerformed(ActionEvent e) {
                // create callback parameter to send
                MutableVariant text = new MutableVariant(myPanel.getFieldText());
                // call callback with parameters (if necessary)
                PluginUtils.callFunction(appContext, c, f, text);
            }
        });
    }
}, "f");

```

This is the resulting the example panel:



Once complete, just copy the `<plugin>.jar` file to the `Algoird/plugin` folder and that's it!

With this feature a lot of improvements can be added to Algoird, like GPIO communications, a true 2D game engine (planned for future development), mathematical functions, etc. Everything you want to teach or command can be added with this powerful scripting language!

Video game development



One principle of Algod is to be fun, because when it is fun, learning becomes a pleasure. What is more fun than creating your own game?

The game above contains only 300 lines of source code and this include all the graphics and animated stars. You can play it from Examples > games > star battle.al.

Tutorials

In this simple tutorial, we will see how to animate a spaceship. Then features such as typing, stamps and events will be discussed.

The first steps of the program are to hide the turtle, create a spaceship and draw it.

```
algo.hide();

// ship
set ship = object () {

  // define its position
  set x = 0;
  set y = 150;

  // draw the ship
  set stamp = algo.stamp.clone (
    array {
      {-1, -1, -1, 10, -1, -1, -1},
      {-1, -1, -1, 10, -1, -1, -1},
      {-1, -1, 02, 10, 02, -1, -1},
```

```
      {10, -1, 02, 10, 02, -1, 10},
      {10, 02, 02, 10, 02, 02, 10},
      {10, 02, 10, -1, 10, 02, 10},
      {10, 02, 02, -1, 02, 02, 10},
      {10, -1, -1, -1, -1, -1, 10},
    }, 7
  );

  // draw it
  set draw = function () {
    algo.goTo (x, y);
    stamp.draw ();
  };
};
```

Note how objects are defined:

```
set ship = object () {};
```

In AL everything is an expression. An object is defined in the same way as a number or a string. Objects, functions and arrays are all declared using the same expression syntax:

```
set [name] = [something];
```

In the case of objects, parenthesis are used for inheritance and {} are used for members. Then to define members of an object, all you need to do is to define another expression within the object:

```
set o = object () {
  set attribute = 7;
  set method = function () {
    // do something
  };

  set nested = object () {
    set method = function () {
    };
  };
};
```

The semi-colons in this code are optional.

Note: In AL, objects are directly created with their declaration. An object can be used immediately after it is created. If some more objects of the same class are needed, it is possible to clone the initial object.

The next concept to introduce is a stamp. A stamp works by cloning (creating a new instance of an

existing object) of the `algo.stamp` object.

The syntax begins with `set`:

```
set stamp = algo.stamp.clone ();
```

A stamp contains two pieces of information: a two dimensional array of colours and the size of a pixel. In AL, an array is declared using the `array` keyword.

```
set a = array {1, 2, 3, 4};
```

A nested array does not require a keyword.

```
set a = array {1, {2, {3, 4}}, 5, {6, 7}}
```

This example represents a tree. It demonstrates how simple it is to define data structures in AL. The AL language is functional and uses the power of `map / filter / reduce`, similar to Python.

Numbers can be replaced by a function, or objects and array of functions, etc. Imagine the capabilities of this kind of flexibility.

Now the image needs to be drawn on the screen.

There are two steps to draw a stamp:

```
algo.goTo(x,y);  
stamp.draw();
```

If we draw the stamp again in another position, then AL will draw an additional ship. This will create two stamps on the screen. To create an animation, we will limit the number of simultaneous stamps on the screen.

```
algo.setStack (1); // only one stamp in stack
```

The object can now be animated with an event:

```
util.pulse (function () {  
  ship.draw();  
}, 40);
```

AL is a complete functional language. Functions can be passed as parameters and returned as results. Events are based on a callback mechanism. If a function is passed as a parameter, then it is only

called when necessary. In this case, every 40 milliseconds.

Up to this point, nothing is moving. To show some animation, let us modify the position each time like this:

```
util.pulse (function () {  
  ship.y--; // Update position  
  ship.draw();  
}, 40);
```

Now we will add the ability to move the ship according to the mouse position with the event `algo.onMove()`.

```
algo.onMove (function (x, y) {  
  ship.x = x;  
});
```

Note: The mouse coordinates are given in the `x` and `y` parameters of the callback function. Thus it is possible to connect the ship `x` and `y` coordinates to the mouse `x` and `y` coordinates.

That's it! Now you are able to move a stamp in Algold. This example can be used as the basis of a complete game.

The steps of the program are:

- 1) Define objects, their coordinates, their graphic stamp(s), their draw method etc.
- 2) Hide the turtle.
- 3) Determine how many stamps should be drawn simultaneously.
- 4) Create frame drawing with `util.pulse`.
- 5) Create behaviours with Algold's events like `onMove`, `onClick` (or `onTouch`, `onGravity` and other sensors on Android).

Conclusion

Algold is a great free tool, to learn or to teach programming. For further questions, suggestions or ideas, you can contact me at cyann74@gmail.com or try the forum at <http://forum.algold.net>.

Sonic π

SONIC PI AT CHRISTMAS

Learning to program with Sonic Pi

Good King Wenceslas



SKILL LEVEL : BEGINNER



Claire Price

MagPi Writer

Sonic Pi was developed by Sam Aaron and is an excellent, easy and creative way to learn programming, especially as Ruby is embedded. It uses the MIDI note numbering system to play sounds and this means you don't have to be a musical genius to make some music! A good MIDI reference table can be found at http://www.midikits.net/midi_analyser/midi_note_numbers_for_octaves.htm

Getting started

If you are using the latest version of NOOBS or Raspbian Wheezy then Sonic Pi should already be installed. If you do not see it on your Raspberry Pi desktop, you can find Sonic Pi under "Programming" in the main menu. However, if you have older versions of these you either need to download the latest image files or you could type in the following into your terminal:

```
sudo apt-get update
sudo apt-get install sonic-pi
```

It is important that you update Raspbian before downloading Sonic Pi otherwise Sonic Pi won't work.

To hear the sound generated, you will need

speakers or a pair headphones - assuming you can't get sound through your monitor/screen. Plug them into the sound jack port on your Raspberry Pi (see Model A/B diagram below).

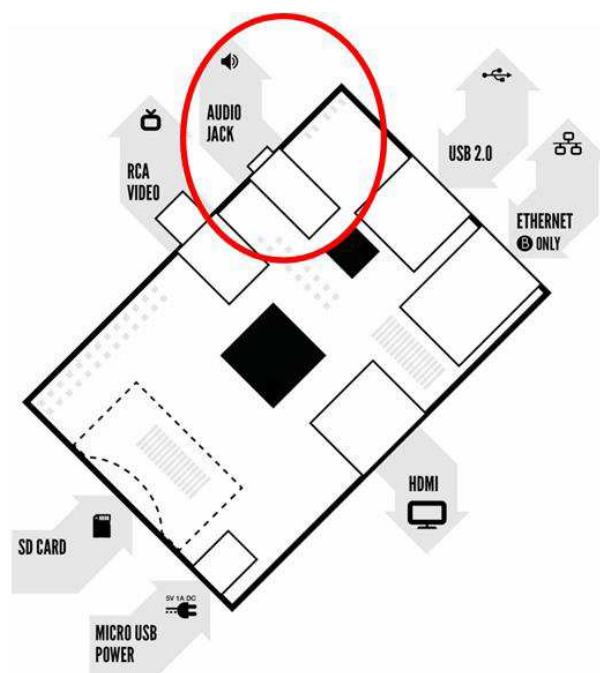

Now we have everything set up, let's make some music!

Making sounds

Open up Sonic Pi. You will see three panes (see screenshot on the next page).

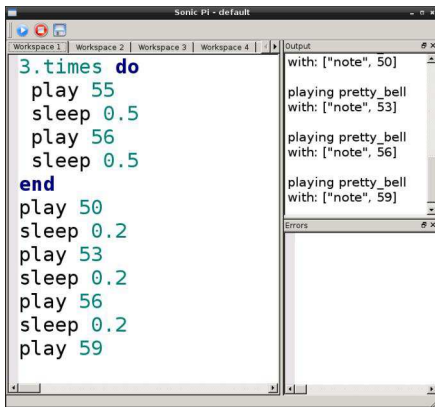

In the large pane type in:

```
play 48
```

By typing this we are telling the program you want to play MIDI note 48, which is the equivalent of playing a C on a piano. To hear it, we need to press Run. This is the triangle button at the top of the page. We should hear a note and in the output pane (which is found on the top right of the screen) we will see what is happening (i.e. note 48 is playing). If you make a mistake while typing in the code, don't worry. The bottom right hand pane will show you your mistake. Try typing in,

```
pjoy 48
```

and see what happens when you press Run.

To create a tune we need to play multiple notes. Let's type in the following:

```
play 48  
play 52  
play 55
```

Press Run. You will notice the three notes are played together. This is great if we want to play a number of notes at the same time, but no good if we want to play separate notes. So to make sure the notes play one after another we need to type `sleep` followed by the number of seconds we want to wait between notes. For instance, if we want a 1 second wait, we would type `sleep 1`.

Let's try putting this into what we have just written. Type in the following:

```
play 48  
sleep 1  
play 52  
sleep 0.5  
play 55
```

Press Run. Can you hear how changing the timings between the notes changes how the melody sounds?

Writing chords

We may want to introduce chords into our tunes. The easiest way to do this is to use the `play_chord` function:

```
play_chord [48,52,55]
```

This tells the program we want to play notes 48, 52 and 55 at the same time. By adding the `sleep` function after `play_chord` we can change the timings between notes (see previous section). Try this out by typing:

```
play_chord [48,52,55]  
sleep 1  
play 52
```

Using loops

If we wanted to repeat this section, we could rewrite everything we just typed or we could use a loop. This is achieved by using `times do`. By writing a number in front of `times do` we can get the program to repeat the section that many times. So if we write `2.times do` everything will be repeated twice. If we write `3.times do` everything will be repeated three times and so on. Adding `end` at the bottom of this section tells the program we only want to repeat this section.

```
2.times do  
  play 48  
  sleep 1  
  play 52  
  sleep 0.5  
end
```

Press Run. You should hear all the notes played twice in the loop.

Playing patterns

In our tune we may have a series of notes that require the same timing between each note, e.g.

```
play 48
sleep 1
play 52
sleep 1
play 55
sleep 1
```

There is nothing wrong with writing the code as in the example, but we could write it another way:

```
play_pattern_timed [48,52,55],[1]
```

This is a great way to write sequences as it is more concise and reduces the chance of error as you do not need to repeatedly type `play` and `sleep`. We can also use this format to shuffle, reverse and sort the notes we want to play.

By adding `.shuffle`, the program will play the notes in a random order:

```
play_pattern_timed [48,52,55].shuffle,[1]
```

Note the `.shuffle` comes after the notes. If it is placed after the `sleep` command, i.e. `[1]`, then the notes will be played in the exact order we have written them. Try it and see:

```
play_pattern_timed [48,52,55],[1].shuffle
```

We can also reverse the order of the notes we have asked the program to play by using `.reverse`

```
play_pattern_timed [48,52,55].reverse,[1]
```

Again if we put `.reverse` after the `[1]` the notes will be played in the order they have been typed.

We can also use `.sort` to order the pattern of notes we have written. This works particularly

well if we have written a sequence of notes in any sequence and then decide what we really want is for the notes to be played in numerical order. For instance, we might type,

```
play_pattern_timed [52,48,55],[1]
```

but what we actually want is for the notes to be played 48, 52, 55. By adding `.sort` this can be achieved:

```
play_pattern_timed [52,48,55].sort,[1]
```

Playing two tunes at once

When writing a tune we may want to have multiple melodies playing at the same time, like when someone is playing a piano with both their right and left hands. To do this we use `in_thread do`.

```
in_thread do
  play 48
  sleep 1
  play 52
  sleep 1
end

in_thread do
  2.times do
    play 55
    sleep 1
  end
end
```

The sections we want to use, we encapsulate in `in_thread do` and `end` so the program knows where to start and finish. The program will then play these two sections at the same time. We can also use other functions within the `in_thread do` too, in this case `2.times do`.

Changing the synth

`pretty_bell` is the default synth, but this can be changed. There are a number of different synth sounds to choose from. These are: `dull_bell`, `pretty_bell` (the default synth), `fm`, `beep` and `saw_beep`.

To change the synth, we use `with_synth` followed by the name of the synth we want to use (in quotation marks, “ ”), e.g.

```
with_synth "dull_bell"
```

Anything that follows this command will be played with this synth. Let's try it out:

```
with_synth "dull_bell"  
play 48
```

You can hear the note sounds very different even though the same note is being played. Try out the other synths and see which you prefer.

Now let's write a tune in Sonic Pi!

Good King Wenceslas

As it is the Christmas season, it seems like a good idea to start by writing a Christmas carol. Good King Wenceslas is a good carol to choose as we can use some of the functions we have discussed.

The first section of Good King Wenceslas is repeated twice so let's start with:

```
2.times do
```

A lot of this section is the same pattern, i.e. there is a sequence of notes to be played with the same timings so we can use `play_pattern_timed`. Remember the indents:

```
  play_pattern_timed [55,55,55,57,55,55],[0.5]  
  play 50  
  sleep 1  
  play_pattern_timed [52,50,52,54],[0.5]  
  play 55  
  sleep 1  
  play 55  
  sleep 1
```

Now we need to tell the program to only repeat this section so we type:

```
end
```

Now we can finish off the rest of the tune:

```
  play_pattern_timed [62,60,59,57,59,57],[0.5]  
  play 55  
  sleep 1  
  play_pattern_timed [52,50,52,54],[0.5]  
  play_pattern_timed [55,55],[1]  
  play_pattern_timed [50,50,52,54,55,55],[0.5]  
  play 57  
  sleep 1  
  play_pattern_timed [62,60,59,57],[0.5]  
  play_pattern_timed [55,60],[1]  
  play 55  
  sleep 2
```

So the finished tune should look something like this:

```
2.times do  
  play_pattern_timed [55,55,55,57,55,55],[0.5]  
  play 50  
  sleep 1  
  play_pattern_timed [52,50,52,54],[0.5]  
  play 55  
  sleep 1  
  play 55  
  sleep 1  
end  
play_pattern_timed [62,60,59,57,59,57],[0.5]  
play 55  
sleep 1  
play_pattern_timed [52,50,52,54],[0.5]  
play_pattern_timed [55,55],[1]  
play_pattern_timed [50,50,52,54,55,55],[0.5]  
play 57  
sleep 1  
play_pattern_timed [62,60,59,57],[0.5]  
play_pattern_timed [55,60],[1]  
play 55  
sleep 2
```

Congratulations you have written your first Christmas carol!

For more information on Sonic Pi see <http://sonic-pi.net/> and have fun creating your next tune!



Sonic π

SONIC PI 2.0

Get your groove on!



Samuel Aaron

Guest Writer

Discover new samples, synths, studio effects and Live Coding

SKILL LEVEL : BEGINNER

Live Coding

The laser beams sliced through the wafts of smoke as the subwoofer pumped bass deep into the bodies of the crowd. The atmosphere was ripe with a heady mix of synths and dancing. However something wasn't quite right in this nightclub. Projected in bright colours above the DJ booth was futuristic text, moving, dancing, flashing. This wasn't fancy visuals, it was merely a projection of a terminal containing Emacs. The occupants of the DJ booth weren't spinning disks, they were writing, editing and evaluating code. This was a Meta-eX (<http://meta-ex.com>) gig. The code was their musical interface and they were playing it live.

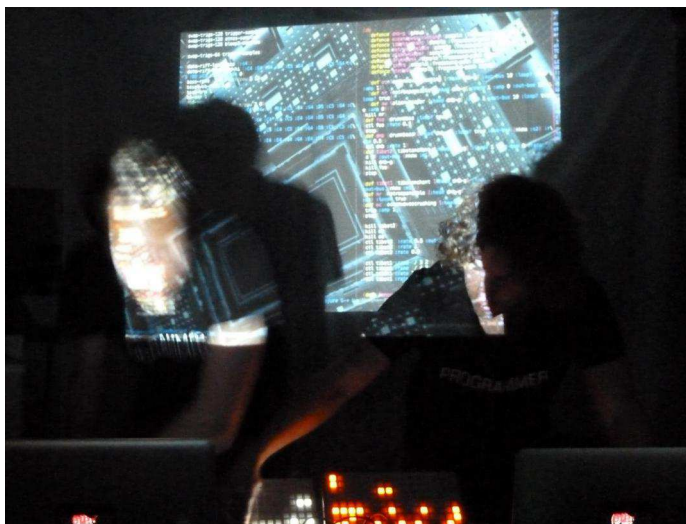

Coding music like this is a growing trend and is often described as Live Coding (<http://toplap.org>). One of the recent directions this approach to music making has taken is the Algorave (<http://algorave.com>) - events where artists code music for people to dance to.

However, you don't need to be in a nightclub to Live Code. As one half of Meta-eX and author of Sonic Pi, I designed version 2 to give you the power to Live Code music anywhere you can take your Raspberry Pi and a pair of headphones, or some speakers. Once you reach the end of this article, you'll be programming your own beats and modifying them live. Where you go afterwards will only be constrained by your imagination.

Getting Sonic Pi v2.0

For this article you will need version 2.0 of Sonic Pi. Sonic Pi is now included in the latest release of Raspbian. You should see the Sonic Pi icon on the Raspberry Pi desktop. If you are using an older release of Raspbian, you can update to Sonic Pi version 2.0 with:

```
sudo apt-get install sonic-pi
```

You can also open Sonic Pi by clicking on the main menu, and looking within Education -> Sonic Pi.

What's New?

Some of you may have already had a play around with Sonic Pi. Hopefully you all had fun making beeps of different pitches. You can take all the music coding skills you've learned with version 1 and apply it to version 2. For those of you that have yet to open Sonic Pi, now is definitely the time to give it a try. You'll be amazed with what you can do with it. Here's a quick list of the major new features:

- * Ships with over 20 synth sounds
- * Ability to play any wav or aiff sample file
- * Ships with over 70 samples
- * Extremely accurate timing
- * Support for over 10 studio effects: reverb, echo, distortion, etc.
- * Support for Live Coding: changing the code while it runs

Let's have a look at all of these features.

Playing a drum loop

Let's code up a simple drum loop. We can use the amen break to get us started. In the main code editor window of Sonic Pi, type the following and then hit the Run button:

```
sample :loop_amen
```

Boom! Instant drums! Go on, press it a few times. Have fun. I'll still be here when you've finished.

But that's not all. We can mess around with the sample. Try this:

```
sample :loop_amen, rate: 0.5
```

Oooh, half speed. Go on, try changing the rate. Try lower and higher numbers. What happens if you use a negative number?

What if we wanted to play the loop a few times over? One way to do this is to call sample a few times with some sleeps in between:

```
sample :loop_amen
sleep 1.753
sample :loop_amen
sleep 1.753
sample :loop_amen
```

However, this could get a bit annoying if you wanted to repeat it 10 times. So we have a nice way of saying that with code:

```
10.times do
  sample :loop_amen
  sleep 1.753
end
```

Of course, we can change the 10 to whatever number we want. Go on, try it! What if we want to loop forever? We simply say loop instead of 10.times. Also, I'm sure you're asking what the magic 1.753 represents and how I got it. Well, it is the length of the sample in seconds and I got it because I asked Sonic Pi:

```
puts sample_duration :loop_amen
```

And it told me 1.753310657596372 - I just shortended it to 1.753 to make it easier for you to type in. Now, the cool thing is, we can combine this code and add a variable for fun:

```
sample_to_loop = :loop_amen
sample_rate = 0.5

loop do
  sample sample_to_loop, rate: sample_rate
  sleep sample_duration sample_to_loop, rate:
sample_rate
end
```

Now, you can change the :loop_amen to any of the other loop samples (use the auto-complete to discover them). Change the rate too. Have fun!

For a complete list of available samples click the Help button.

Adding Effects

One of the most exciting features in version 2.0 of Sonic Pi is the support for studio effects such as reverb, echo and distortion. These are really easy to use. For example take the following sample trigger code:

```
sample :guit_e_fifths
```

To add some reverb to this, we simply need to wrap it with a `with_fx` block:

```
with_fx :reverb do
  sample :guit_e_fifths
end
```

To add some distortion, we can add more fx:

```
with_fx :reverb do
  with_fx :distortion do
    sample :guit_e_fifths
  end
end
```

Just like synths and samples, FX also supports parameters, so you can tinker with their settings:

```
with_fx :reverb, mix: 0.8 do
  with_fx :distortion, distort: 0.8 do
    sample :guit_e_fifths
  end
end
```

Of course, you can wrap FX blocks around any code. For example here's how you'd combine the `:ixi_techno` FX and our drum loop:

```
with_fx :ixi_techno do
  loop do
    sample :loop_amen
    sleep sample_duration :loop_amen
  end
end
```

For a complete list of FX and their parameters click the Help button.

Live Coding a Synth Loop

Now we've mastered the basics of triggering

samples, sleeping and looping, let's do the same with some synths and then jump head first into live coding territory:

```
loop do
  use_synth :tb303
  play 30, attack: 0, release: 0.3
  sleep 0.5
end
```

So, what do the numbers mean in this example? Well, you could stop it playing, change a number, then start it and see if you can hear the difference. However all that stopping and starting gets quite annoying. Let's make it possible to live code so you can instantly hear changes. We need to put our code into a named function which we loop:

```
define :play_my_synth do
  use_synth :tb303
  play 30, attack: 0, release: 0.3
  sleep 0.5
end

loop do
  play_my_synth
end
```

Now when you run this it will sound exactly the same as the simpler loop above. However, now we have given our code a name (in this case, `play_my_synth`) we can change the definition of our code while things run. Follow these steps:

1. Write the code above (both the define and loop blocks)
2. Press the Run button
3. Comment out the loop block (by adding `#` at the beginning of each line)
4. Change the definition of your function
5. Press the Run button again
6. Keep changing the definition and pressing Run!
7. Press Stop

For example, start with the code above. Hit Run. Comment out the loop block then change the `play` command to something different. Your code should look similar to this:

```

define :play_my_synth do
  use_synth :tb303
  play 45, attack: 0, release: 0.3, cutoff:
70
  sleep 0.5
end

# loop do
#   play_my_synth
# end

```

Then hit the Run button again. You should hear the note go higher. Try changing the attack, release and cutoff parameters. Listen to the effect they have. Notice that attack and release change the length of the note and that cutoff changes the 'brightness' of the sound. Try changing the synth too - fun values are :prophet, :dsaw and :supersaw. Press the Help button for a full list.

There are lots of other things we can do now, but unfortunately I'm running out of space in this article so I'll just throw a couple of ideas at you. First, we can try some randomisation. A really fun function is rrand. It will return a random value between two values. We can use this to make the cutoff bounce around for a really cool effect. Instead of passing a number like 70 to the cutoff value, try rrand(40, 120). Also, instead of only playing note 45, let's choose a value from a list of numbers. Try changing 45 to chord(:a3, :minor).choose. Your play line should look like this:

```

play chord(:a2, :minor).choose, attack: 0,
release: 0.3, cutoff: rrand(40, 120)

```

Now you can start experimenting with different chords and range values for cutoff. You can do something similar with the pan value too:

```

play chord(:a2, :minor).choose, attack: 0,
release: 0.3, cutoff: rrand(40, 120), pan:
rrand(-1, 1)

```

Now throw some FX in, mess around and just have fun! Here are some interesting starting points for you to play with. Change the code, mash it up, take it in a new direction and perform for your friends!

```

# Haunted Bells
loop do
  sample :perc_bell, rate: (rrand 0.125,1.5)
  sleep rrand(0.5, 2)
end

```

```

# FM Noise
use_synth :fm
loop do
  p = play chord(:Eb3, :minor).choose -
[0, 12, -12].choose, divisor: 0.01, div_slide:
rrand(1, 100), depth: rrand(0.1, 2), attack:
0.01, release: rrand(0.1, 5), amp: 0.5
  p.control divisor: rrand(0.001, 50)
  sleep [0.5, 1, 2].choose
end

```

```

# Driving Pulse
define :drums do
  sample :drum_heavy_kick, rate: 0.75
  sleep 0.5
  sample :drum_heavy_kick
  sleep 0.5
end
define :synths do
  use_synth :mod_pulse
  use_synth_defaults amp: 1, mod_range: 15,
attack: 0.03, release: 0.6, cutoff: 80,
pulse_width: 0.2, mod_rate: 4
  play 30
  sleep 0.25
  play 38
  sleep 0.25
end
in_thread(name: :t1){loop{drums}}
in_thread(name: :t2){loop{synths}}

```

```

#tron bike
loop do
  with_synth :dsaw do
    with_fx(:slicer,freq: [4,8].choose) do
      with_fx(:reverb,room: 0.5, mix: 0.3) do
        n1 = chord([:b1, :b2, :e1, :e2, :b3,
:e3].choose, :minor).choose
        n2 = chord([:b1, :b2, :e1, :e2, :b3,
:e3].choose, :minor).choose
        p = play n1, amp: 2, release: 8,
note_slide: 4, cutoff: 30, cutoff_slide: 4,
detune: rrand(0, 0.2)
        p.control note: n2, cutoff: rrand(80,
120)
      end
    end
  end
  sleep 8
end

```



Reader Feedback

You guys are doing good work. Continue!

Victor R

I just wanted to let you know that I really enjoyed Martin Hodgson's Python port of "Strongholds of the Dwarven Lords". I plan on sharing it with some of my middle school students.

Jason K

After taking the plunge and purchasing my very first Raspberry Pi, I stumbled upon your great magazine. As a complete novice to the world of the Raspberry Pi, The MagPi magazine is an excellent resource. The variety of articles, guides and project ideas are an inspiration. There really is something for everyone.

Caron J

I recently discovered your fantastic magazine, which brought back great memories of typing in code from magazines into my

VIC-20. I look forward to getting to know my little computer better through your magazine.

Lynn W

I really love The MagPi and hope that I get the skills and find the time to build something amazing that can be published as well.

Henner

Keep up the good work and make sure you keep the simple type in code each issue.

Allan

Cannot wait to get my printed copies. Printed versions are so much easier to use.

Roger

I really enjoy the magazine with my 10 year old daughter!

David

I just wanted you to know that I love your magazine. It is well laid out and highly informative. It is the perfect introduction for students

(and also hobbyists) to the wonderful world of Raspberry Pi. Believe me when I say, you are helping create the next generation of engineers, makers, hackers and artists.

David S

Your publication is outstanding! The variety of well composed articles in each issue are incredibly helpful. Please keep up the good work!

T Gomez

Great job in making possibly the most useful magazine I have ever read! I'm only 14 years old and your magazine has inspired me to start programming. Thanks!

J Forster

If you are interested in writing for The MagPi or would like to join the team in the production of the magazine, then please get in touch by emailing the editor at:

editor@themagpi.com

The MagPi is a trademark of The MagPi Ltd. Raspberry Pi is a trademark of the Raspberry Pi Foundation. The MagPi magazine is collaboratively produced by an independent group of Raspberry Pi owners, and is not affiliated in any way with the Raspberry Pi Foundation. It is prohibited to commercially produce this magazine without authorization from The MagPi Ltd. Printing for non commercial purposes is agreeable under the Creative Commons license below. The MagPi does not accept ownership or responsibility for the content or opinions expressed in any of the articles included in this issue. All articles are checked and tested before the release deadline is met but some faults may remain. The reader is responsible for all consequences, both to software and hardware, following the implementation of any of the advice or code printed. The MagPi does not claim to own any copyright licenses and all content of the articles are submitted with the responsibility lying with that of the article writer. This work is licensed under the Creative Commons Attribution-NonCommercial-ShareAlike 3.0 Unported License. To view a copy of this license, visit:

<http://creativecommons.org/licenses/by-nc-sa/3.0/>



Alternatively, send a letter to Creative Commons, 444 Castro Street, Suite 900, Mountain View, California, 94041, USA.