

OPERATING AND SERVICE MANUAL

WILLARD MODELS 87XX1 AND 89081

READ/WRITE TAPE TRANSPORTS

© 1971 BY WILLARD LABORATORIES, INC.,
4221 REDWOOD AVENUE, LOS ANGELES,
CALIFORNIA 90066

REPUBLISHED OCTOBER 1972 BY GTEIS-NOVAR
CORPORATION, 2400 CHARLESTON ROAD,
MOUNTAIN VIEW, CALIFORNIA 94040

FOREWORD

GTE Information Systems republishes this Operating and Service Manual by prior arrangement with Willard Laboratories Incorporated, Los Angeles, California.

The manual is republished in GTEIS-Novar Corporation's standard format and type style and with retouched and/or redrawn illustrations. The contents and technical accuracy are the same as the original manual.

Additional copies of this manual should be requested from Product Support, Publications, 2400 Charleston Road, Mountain View, California (94040).

TABLE OF CONTENTS

<u>SECTION</u>	<u>PARAGRAPH</u>	<u>PAGE</u>
1	GENERAL DESCRIPTION	1-1
	1.1 INTRODUCTION	1-1
	1.2 PHYSICAL DESCRIPTION	1-1
	1.3 FUNCTIONAL DESCRIPTION	1-1
	1.4 POWER REQUIREMENTS	1-2
	1.5 ELECTRICAL AND MECHANICAL SPECIFICATIONS	1-2
	1.6 INTERFACE SPECIFICATIONS	1-2
2	INSTALLATION AND INITIAL CHECKOUT	2-1
	2.1 INITIAL UNCRATING OF THE TRANSPORT	2-1
	2.2 POWER CONNECTION	2-1
	2.3 INITIAL CHECKOUT	2-1
	2.4 INTERFACE CONNECTIONS	2-3
	2.5 RACK MOUNTING THE TRANSPORT	2-4
3	OPERATION	3-1
	3.1 INTRODUCTION	3-1
	3.2 LOADING THE TAPE	3-1
	3.3 UNLOADING THE TAPE	3-1
	3.4 MANUAL CONTROLS	3-1
	3.4.1 POWER	3-1
	3.4.2 LOAD	3-1
	3.4.3 REWIND	3-2
	3.4.4 ON-LINE	3-2
	3.4.5 WRT EN (Write Enable)	3-3
	3.4.6 HI DEN (High Density) (Optional)	3-3
	3.4.7 FORWARD	3-3
	3.4.8 REVERSE	3-3
	3.4.9 RESET	3-3
	3.5 INTERFACE INPUTS	3-3
	3.5.1 Select (SEL)	3-4
	3.5.2 Forward Command (FWDC)	3-4
	3.5.3 Reverse Command (REVC)	3-4
	3.5.4 Rewind Command (RWC)	3-4
	3.5.5 Write Enable Command (WEC)	3-4
	3.5.6 Write Data Lines (WDP, WD0-7 for 9-Channel; WDP, WD2-7 for 7-Channel)	3-4
	3.5.7 Write Data Strobe (WDS)	3-5
	3.5.8 Write Amplifier Reset (WARS)	3-5
	3.5.9 Read Threshold (RTH)	3-5
	3.5.10 Off-Line (OFFC)	3-5
	3.5.11 High Density Select (HDS) (Optional)	3-5

TABLE OF CONTENTS (Continued)

<u>SECTION</u>	<u>PARAGRAPH</u>	<u>PAGE</u>
	3.6 INTERFACE OUTPUTS	3-6
	3.6.1 Ready (RDYI)	3-6
	3.6.2 Read Data (RDP, RD0-RD7, 9- Channel; RDP, RD2-RD7, 7-Channel)	3-6
	3.6.3 Read Data Strobe (RDS)	3-6
	3.6.4 On-Line (OLI)	3-6
	3.6.5 Load Point (LDP)	3-6
	3.6.6 End Of Tape (EOT)	3-6
	3.6.7 Rewinding (RWD)	3-6
	3.6.8 File Protect (FPI)	3-7
	3.6.9 High Density Indicator (HDI)	3-7
	3.7 INTERFACE TIMING	3-7
4	THEORY OF OPERATION	4-1
	4.1 INTRODUCTION	4-1
	4.2 CONTROL LOGIC	4-1
	4.2.1 Bring-To-Load Point	4-1
	4.2.2 Monitor Commands After Initial Loading Of Tape	4-5
	4.2.3 Rewind Command	4-7
	4.3 POWER SUPPLY	4-8
	4.4 SERVO AMPLIFIERS AND TAPE STORAGE SYSTEM	4-9
	4.4.1 Capstan Servo	4-9
	4.4.2 Reel Servos	4-9
	4.5 DATA ELECTRONICS	4-10
	4.5.1 Introduction	4-10
	4.5.2 Data Recording	4-10
	4.5.3 Circuit Description	4-12
	4.5.4 Dual Gap Option	4-15
5	MAINTENANCE	5-1
	5.1 INTRODUCTION	5-1
	5.2 FUSE REPLACEMENT	5-1
	5.3 TRANSPORT CLEANING	5-1
	5.4 ELECTRICAL ADJUSTMENTS	5-1
	5.4.1 +5V Regulator	5-2
	5.4.2 -5V Regulator	5-2
	5.4.3 BOT And EOT Amplifiers	5-2
	5.4.4 Ramp Timing	5-2
	5.4.5 Tape Speed	5-2
	5.4.6 Read Amplifier Gain	5-3
	5.4.7 Read Data Strobe Adjustment	5-3
	5.4.8 Write One/Shot Adjustments (Performed After 5.5.1)	5-3

TABLE OF CONTENTS (Continued)

<u>SECTION</u>	<u>PARAGRAPH</u>	<u>PAGE</u>
5.5	MECHANICAL ADJUSTMENTS	5-4
	5.5.1 Read Skew Adjustments	5-4
	5.5.2 Replacement Of The Precision Magnetic Head And Drive Assembly	5-6
	5.5.3 Reel Servo Belt Tension	5-6
	5.5.4 Tape Tension	5-6
	5.5.5 Reel Brake Adjustment	5-8
	5.5.6 Roller Guide Adjustment	5-8
	5.5.7 Write Enable Solenoid Assembly Adjustment	5-8
	5.5.8 Arm Limit Rubber Bumpers	5-9/5-10
APPENDIX A		
	Bill Of Material	A-2
	Spare Parts List	A-4
	Part Number Cross Reference	A-5
	Parts List For Power Supply Assembly 20-118, 20-341	A-7
	Parts List For PCB Assembly Control 20-163L	A-8
	Parts List For PCB Assembly Data A 20-355	A-10
	Power Fail Restart Option (WLI Part No. 20-309 and 20-344)	A-12
	Parts List For PCB Assembly - Power Fail Restart 20-309B	A-14

LIST OF FIGURES

<u>FIGURE</u>	<u>TITLE</u>	<u>PAGE</u>
1-1		Appendix
1-2	Interface Configuration	1-4
2-1	Wiring Diagram For Power	2-2
3-1	Tape Threading	3-2
3-2	Waveforms For Reading And Writing	3-8
4-1	Organization Of The Transport	4-2
4-2	Load Sequence Waveforms	4-4
4-3	Waveforms For Rewind To Load Point	4-8
4-4	Inter-Record Gap Format For 9 And 7 Tracks	4-11
4-5	File Gap Format For 9 And 7 Tracks	4-13
5-1	Skew Waveforms	5-5
5-2	Tape Tension Adjustment	5-7

LIST OF TABLES

<u>TABLE</u>	<u>TITLE</u>	<u>PAGE</u>
1-1	Specifications Summary	1-2
2-1	Power Connections	2-1
2-2	Interface Connections	2-4

SECTION I
GENERAL DESCRIPTION

1.1 INTRODUCTION

This manual provides operation and maintenance information for a Willard Laboratories series of synchronous tape transports. Those models which are described in this manual are given in Table 1-1.

1.1.1 These transports all have tape speeds of 12.5ips and can record in either 7 or 9 tracks, depending on the model. In the 7-track models, densities are available ranging from 556 or 800BPI. In the 9-track model, data recording is performed at 800BPI.

1.1.2 Data recording on all transports is IBM compatible. The recorded information may be completely recovered when played back on an IBM digital tape transport or its equivalent. In addition, these units are plug-for-plug compatible with many other industry transports.

1.2 PHYSICAL DESCRIPTION

Figure 1-1 (shown in the Appendix), the outline and installation drawing, shows the standard dimensions for these models. The units are designed to be mounted in a 19-inch EIA rack.

1.2.1 Two hinged printed circuit boards contain the data electronics and control circuitry. Interface signals are brought into and out of these circuit boards through three printed circuit edge connectors. Access to these connectors is from the rear.

1.2.2 A dust cover is provided to protect the magnetic tape, the read/write head, and capstan from any contaminants. Operational controls, mounted on a control panel, are accessible with the dust cover closed.

1.3 FUNCTIONAL DESCRIPTION

The transport may be broadly divided into the control section and the data electronics section. The control section consists of circuitry necessary to control starting and stopping of tape motion, while the data electronics consists of circuitry necessary to read and write information on tape.

1.3.1 A single capstan drive is used for controlling tape motion during read, write, and rewind modes. This capstan is controlled by a velocity servo which utilizes tachometer feedback information from the capstan motor to control tape speed. A ramp generator precisely controls acceleration and deceleration during starting and stopping.

1.3.2 Independent supply and take up reel motors in conjunction with buffer storage arms maintain constant tape tension during the relatively fast starts and stops of the capstan. The reel servo amplifiers sense the displacement of the storage arms by use of photoelectric sensors.

An error signal is then amplified and used to maintain the storage arms in their nominal operating position.

1.3.3 Control logic is provided to allow tape, once it has been loaded, to be brought manually to the load point, placed in forward motion, rewound, and unloaded. A reset button allows manual halting of any control command.

1.3.4 The logic allows external control of tape motion, reading, and writing. Photoelectric sensors are provided for detecting the beginning-of-tape (BOT) tab and the end-of-tape (EOT) tab. The BOT signal is used internally for control, while the EOT signal is transmitted as a level to the customer interface.

1.3.5 System interlocks are provided to protect the tape from damage due to component or power failure. A disc braking system prevents tape spillage after loss of power.

1.3.6 The data electronics accepts external data signals and write commands. These commands cause information to be recorded in Non Return to Zero format once the tape has been brought up to speed. Inter-Record Gaps (IRG'S) are provided by the customer controller. Data which is read back is presented to the interface along with a strobe signal to indicate that the data is available to be sampled.

1.4 POWER REQUIREMENTS

The transports operate directly from 115 or 230 volt AC ($\pm 10\%$), single phase, 48 to 440Hz power. For power consumption see Table 1-1.

1.5 ELECTRICAL AND MECHANICAL SPECIFICATIONS

Table 1-1 gives electrical and mechanical specifications for the units.

1.6 INTERFACE SPECIFICATIONS

Interface signals are standard DTL/TTL levels.

Table 1-1

SPECIFICATIONS SUMMARY

MODEL NO.	87581 and 89081
TAPE SPEED	12.5ips
DATA DENSITY (BPI)	800/500 and 800

Table 1-1 (Continued)

NUMBER OF TRACKS	7 (IBM) and 9 (SASCI)
START/STOP TIME	30.0 + 2.0MS
INSTANTANEOUS SPEED VARIATION	±3% maximum
VARIATION OF AVERAGE SPEED	±1% maximum
START DISTANCE	0.19 ± 0.02 inches
STOP DISTANCE	0.19 ± 0.02 inches
REWIND SPEED	125ips nominal
DYNAMIC SKEW	75 microinches maximum
STATIC SKEW	100 microinches maximum
REEL SIZE	Up to 8.5 diameter IBM compatible
RECORDING MODE	Non Return to Zero
HEAD TYPE	Single gap with full track erase
TAPE TENSION	8.0 ± 1/2 oz.
TAPE SPECIFICATIONS	0.5 inches wide, 1.5 mil thick, computer grade
ELECTRONICS	All silicon solid state
INTERFACE	DTL/TTL
WEIGHT	35 pounds
MOUNTING	Standard 19 inch rack mount
DIMENSIONS (INCHES)	
HEIGHT:	12.25 inches
WIDTH:	19.00 inches
DEPTH (TOTAL):	12.5 inches

Table 1-1 (Continued)

DEPTH (FROM MOUNTING SURFACE):	10.6 inches
POWER	115/230VAC, 48 to 440Hz, 100 volt amperes
OPERATING TEMPERATURE (ROOM AMBIENT)	40°F to 115°F
RELATIVE HUMIDITY	15 to 95% (non condensation)
ALTITUDE	0 to 20,000 feet
TRUE = LOW =	0 to 0.4V
FALSE = HIGH =	+2.5 to +5V

1.6.1 Wires disconnected from inputs are interpreted as false levels.

1.6.2 Figure 1-2 indicates interface information for use in transmitting signals to the transport or receiving signals from it.

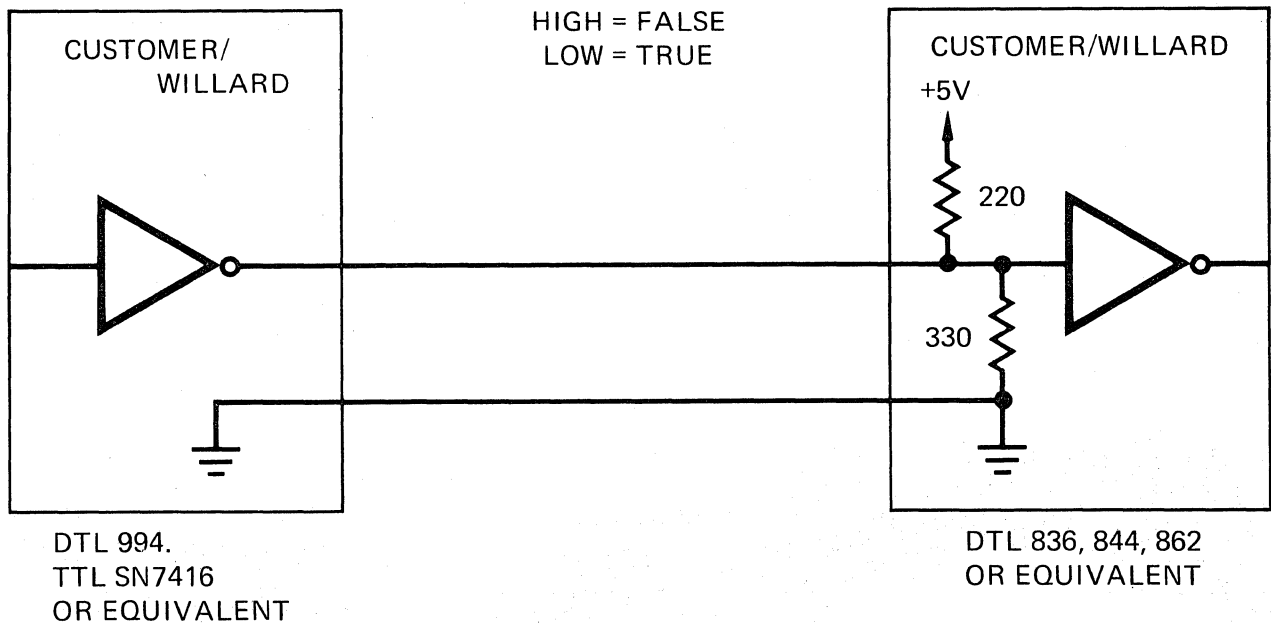

Figure 1-2. Interface Configuration

SECTION II
INSTALLATION AND INITIAL CHECKOUT

2.1 INITIAL UNCRATING OF THE TRANSPORT

The transport should be uncrated carefully so as to minimize the possibility of damage and to uncover any shipping damage or shortages. Begin uncrating by placing the container in the position indicated on the container. Carefully remove the transport along with its shipping frame from the container and verify the packing slip. Perform a visual inspection to ensure that all connectors and the plug-in relay are properly seated. The identification label on the back of the transport should be checked to verify that the unit is the correct model number and is set up for the proper line voltage.

2.2 POWER CONNECTION

If the actual line voltage at the installation is different from that shown on the transport, change the power transformer taps as shown in Table 2-1. A power cord is supplied for plugging into a polarized 115 volt outlet. For other power sockets, substitute the correct plug for the one supplied with the unit. A wiring diagram of the power transformer is shown in Figure 2-1.

Table 2-1

POWER CONNECTIONS

NOMINAL LINE VOLTAGE	LINE INPUT BETWEEN TAPS	CONNECT TAPS
115V	1 and 1	1 and 3 2 and 4
230V	1 and 4	2 and 3

2.3 INITIAL CHECKOUT

After the transport has been uncrated, test the transport controls prior to placing the unit in system operation.

- 2.3.1 The following paragraphs suggest a recommended procedure for verifying correct operation of the transport.
- 2.3.2 Connect the power cord and load the tape on the transport as described in paragraph 3.2.
- 2.3.3 Perform the steps outlined on the following pages to verify correct operation of each of the control buttons.

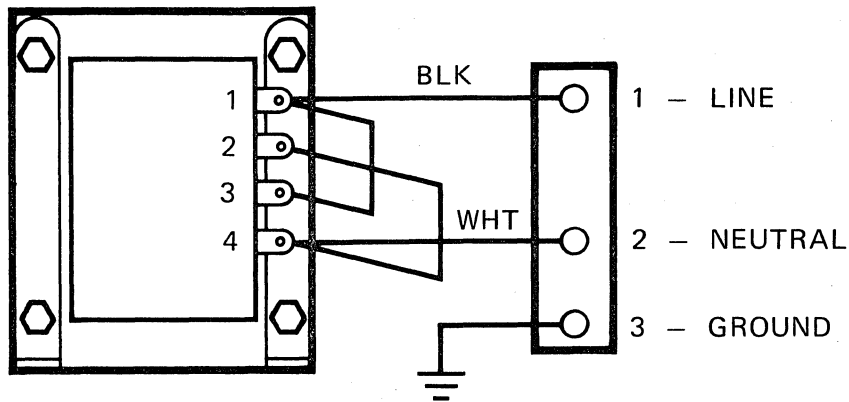

115 VAC

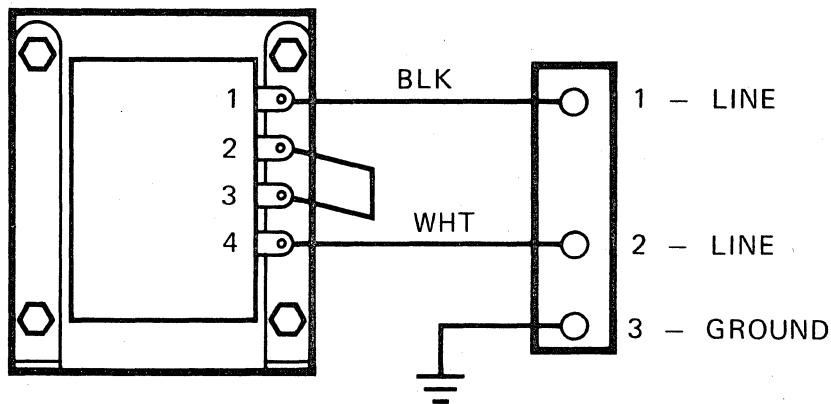

230 VAC

Figure 2-1. Wiring Diagram For Power

1. Depress the POWER switch to apply transport power.
2. Depress the LOAD switch to apply capstan-motor and reel-motor power.
3. Depress the LOAD switch momentarily a second time to initiate a load sequence. The tape will then move forward

until it reaches the BOT tab, and stops. The LOAD indicator lamp will light when the BOT tab reaches the photosensor and remain lighted as long as the tab is at the load point. No further action will result when the LOAD button is depressed.

4. Place the unit on-line by pressing the ON-LINE switch. Observe that the ON-LINE indicator lights. Place the unit off-line by pressing the RESET button and observe that this action extinguishes the ON-LINE lamp.
5. With the transport OFF-LINE, press the FORWARD button. The tape will begin to move forward, but no FORWARD lamp will light. Run several feet of tape onto the take-up reel and press the RESET button to stop the tape. Check that the FORWARD control has no effect if the transport is in the ON-LINE mode.
6. Press the REVERSE switch. The tape will begin to move in a reverse direction. Prior to the tape reaching the BOT tab, press the RESET button to stop the tape motion. Again press the REVERSE switch, but this time allow the BOT tab to reach the photosensor, causing tape motion to halt. Check that the REVERSE button has no effect if the transport is in the ON-LINE mode.
7. Press the FORWARD switch and allow several feet of tape to advance onto the take-up reel. Depress the RESET button, as before, to halt forward motion. Depress the REWIND button momentarily to initiate the rewind mode and light the REWIND indicator. The tape will rewind past the BOT tab, enter the load sequence, return to the BOT tab and stop with the LOAD indicator lighted.

If the REWIND button is momentarily depressed when the tape is at BOT, the LOAD indicator will be extinguished, the REWIND indicator will be lighted, and the tape will rewind until tape tension is lost. The tape may then be removed as described in paragraph 3.3.

2.4 INTERFACE CONNECTIONS

Customer interface equipment should be connected to the three transport edge connectors through a harness of twisted pair wires. These twisted pairs should have a maximum length of 20 feet and should be 22 or 24 gauge wire with at least 1 twist per inch. The three printed circuit edge connectors should be wired by the customer and strain relieved for flexibility. Table 2-2 gives the pin numbers for the interface signals.

2.5 RACK MOUNTING THE TRANSPORT

The tape transport may be rack mounted in a standard EIA rack. Figure 1-1 illustrates the location of rack mounting holes as well as dimensional information for installation. Use the following procedures for rack mounting the transport.

1. Place the transport on a flat surface with the reels facing forward.
2. Remove the three No. 10 cap screws holding the transport to the shipping frame.
3. Locate the socket wrench supplied with the transport. Place the transport in position in the rack and insert the two socket head screws in the access holes on the left of the transport. Do not yet tighten these screws.
4. Place the single screw in the right hand screw hole and tighten using the socket wrench.
5. Tighten the two screws on the right side using the socket wrench.

Table 2-2

INTERFACE CONNECTIONS

Transport Connector Mating Connector			36 Pin Etched PC Edge Connector 36 Pin Elco 00-6007-036-980-002	
SIGNAL PIN	GROUND PIN	INPUT/ OUTPUT	SIGNAL	
J1	C	3	Input	Forward Command (FWDC)
	D	4	Input	High Density Select (HDS) Optional
	E	5	Input	Reverse Command (REVC)
	H	7	Input	Rewind Command (RWC)
	J	8	Input	Select (SEL)
	K	9	Input	Write Enable Command (WEC)
	L	10	Input	Off-Line Command (OFFC)
	F	6	Output	High Density Indicator (HDI)
	M	11	Output	On-Line Indicator (OLI)
	N	12	Output	Rewinding (RWD)
	P	13	Output	File Protect Indicator (FPI)
	R	14	Output	At Load Point Indicator (LPI)

Table 2-2 (Continued)

Transport Connector Mating Connector		36 Pin Etched PC Edge Connector 36 Pin Elco 00-6007-036-980-002		
SIGNAL PIN	GROUND PIN	INPUT/ OUTPUT	SIGNAL	
	T	16	Output	Ready Indicator (RDYI)
	U	17	Output	End Of Tape (EOT)
J102	A	1	Input	Write Data Strobe (WDS)
	C	3	Input	Write Amplifier Reset (WARS)
	E	5	Input	Read Threshold (RTH)
	L	10	Input	Write Data Parity (WDP)
	M	11	Input	Write Data 0 (WD0) } Omit for 7-
	N	12	Input	Write Data 1 (WD1) } Channel Units
	P	13	Input	Write Data 2 (WD2)
	R	14	Input	Write Data 3 (WD3)
	S	15	Input	Write Data 4 (WD4)
	T	16	Input	Write Data 5 (WD5)
	U	17	Input	Write Data 6 (WD6)
	V	18	Input	Write Data 7 (WD7)
J103	2	B	Output	Read Data Strobe (RDS)
	1	A	Output	Read Data Parity (RDP)
	3	C	Output	Read Data 0 (RD0) } Omit for 7-
	4	D	Output	Read Data 1 (RD1) } Channel Units
	8	J	Output	Read Data 2 (RD2)
	9	K	Output	Read Data 3 (RD3)
	14	R	Output	Read Data 4 (RD4)
	15	S	Output	Read Data 5 (RD5)
	17	U	Output	Read Data 6 (RD6)
	18	V	Output	Read Data 7 (RD7)

SECTION III OPERATION

3.1 INTRODUCTION

In this section the manual operation of the unit is described and the functional interface signals are defined.

3.2 LOADING THE TAPE

To load tape on the transport, pull the lever on the supply reel hold down knob forward, place the reel of tape in position, and push the lever back flush to the reel. If it is desired to enable writing, place a write enable ring in the reel prior to mounting.

3.2.1 Thread the tape along the path shown in Figure 3-1. This path is also shown diagrammatically on a decal mounted on the front of the transport. A retaining strip on the take-up reel facilitates take up by allowing the tape to adhere to the reel.

3.2.2 Verify correct seating in the tape guides by manually rotating the supply hub. Once the seating has been checked, depress the POWER switch. Next, depress the LOAD switch, allowing tape tension to be applied to the arms. Examine the tape again for correct positioning. If the tape is not seated correctly, turn power off and reposition the tape. After the tape has been properly seated, press the LOAD switch a second time, causing the tape to move to the BOT. At this point close the dust cover and keep it closed during all subsequent tape operation.

3.3 UNLOADING THE TAPE

Begin unloading of a tape by placing the unit in off-line control. If the tape is positioned at some point after the BOT tab, depress the REWIND button. This action causes the tape to be rewound to the BOT point. REWIND button should be depressed a second time, causing tape to rewind until tape tension is lost. Open the dust cover and wind the tape onto the supply reel. To remove the supply reel pull the lever on the reel hold down knob forward and remove the reel from the hub.

3.4 MANUAL CONTROLS

The following is a description of the operation of the manual controls located on the control panel.

3.4.1 POWER

The POWER switch is an alternate action switch/indicator which turns on the power supplies but does not activate the transport.

3.4.2 LOAD

The LOAD switch is a momentary action switch/indicator. Depressing this switch for the first time after power has been applied to the

unit causes the servos to be energized, thus giving the tape tension. Depressing the switch for a second time causes the tape to move to the BOT point. The LOAD indicator is lighted when the BOT tab is positioned over the photoelectric sensor.

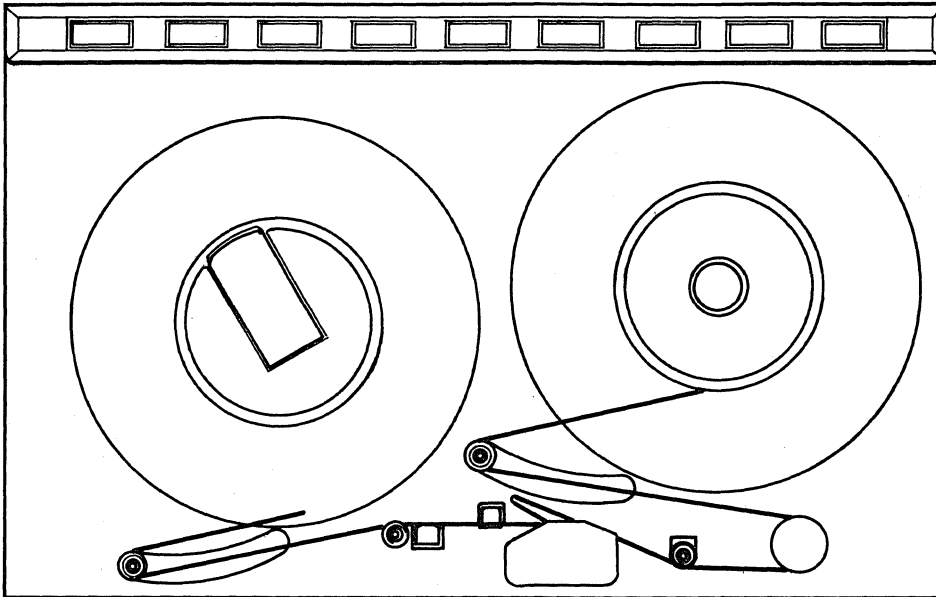

Figure 3-1. Tape Threading

3.4.3 REWIND

The REWIND switch is a momentary switch/indicator which may be used only when the unit is off-line. Depressing this switch causes the tape to rewind to the BOT point. Once the BOT point is reached, the tab will overshoot the sensor, move forward, and stop at the load point.

3.4.3.1 Depressing the REWIND switch when the tape is at the load point (BOT tab under photosensor) causes the tape to rewind until tension is lost.

3.4.4 ON-LINE

The ON-LINE switch is a momentary switch/indicator which is enabled after the tape has been brought through its initial load sequence. Depressing this switch causes the indicator lamp to light and places the transport in a state ready to receive external commands. Depressing the RESET SWITCH causes the lamp to be extinguished and the transport to revert to the off-line mode. The transport will also switch to the off-line mode if an external off-line command is given or if the tape tension is lost. In the off-line mode control commands are accepted only from the control panel switches.

3.4.5 WRT EN (Write Enable)

WRT EN is an indicator lamp which is lighted when a reel with a write enable ring is installed on the supply reel hub.

3.4.6 HI DEN (High Density) (Optional)

The HI DEN switch is an alternate action switch/indicator which is provided only in the 7-track transports where there is a choice of two different densities of recording. When the indicator is lighted, the higher of the two densities is selected; when the indicator is extinguished, the lower of the two densities is selected.

3.4.6.1 An optional feature of the 7-track transports allows the customer to use external high density commands. When this option is selected, a HI DEN indicator is provided with no corresponding control panel switch.

3.4.7 FORWARD

Forward motion of the tape results from depressing the momentary FORWARD switch. This switch is enabled only in the off-line mode of operation, and has no lamp associated with it. Motion will cease if the EOT tab is encountered or if the RESET switch is depressed.

3.4.8 REVERSE

Reverse motion of the tape results from depressing the momentary REVERSE switch. This switch is enabled only in the off-line mode of operation and has no lamp associated with it. Motion will cease if the BOT tab is encountered or if the RESET switch is depressed.

3.4.9 RESET

In the off-line mode of operation depressing the RESET switch will cause the transport to stop forward or reverse motion or stop rewinding. If the transport is in the on-line mode of operation, depressing the RESET switch will cause the unit to revert to the off-line mode.

3.4.9.1 The RESET switch has no effect on the WRT EN, the HI DEN, the LOAD, or the POWER switch.

3.5 INTERFACE INPUTS

The following is a description of the interface signals which must be supplied from the customer controller to the transport. All names correspond to the true level of 0 volts. Barred terms correspond to a false level, which is between +2V and +5V. All schematics show interface signal symbols prefaced with an "I" to indicate a signal transmitted to or from an interface.

3.5.1 Select (SEL)

This level, when true, enables all of the interface inputs in the transport, thus connecting the transport to the controller. All of the interface inputs are gated with the SELECT signal.

3.5.2 Forward Command (FWDC)

This level, when it is true, and the transport is READY, causes the tape to move forward at the specified velocity. A false level of this command causes tape motion to cease. The velocity profile is trapezoidal with nominally equal rise and fall times.

3.5.3 Reverse Command (REVC)

This level, when it is true, and the transport is READY, causes the tape to move in reverse at the specified velocity. A false level of this command causes tape motion to cease. The velocity profile is trapezoidal with nominally equal rise and fall times.

3.5.3.1 Reverse motion of the tape will terminate when the BOT tab is reached. If the tape is at the load point, a REVC true level will be ignored.

3.5.4 Rewind Command (RWC)

This is a pulse which, if the transport is READY, causes the tape to move in the reverse direction at 125ips. Upon reaching the BOT, the rewind ceases and the tape comes to rest at the BOT tab. Minimum width for the REWIND COMMAND is 2US.

3.5.4.1 The REWIND indicator will remain lighted until the tape comes to rest at the BOT.

3.5.5 Write Enable Command (WEC)

This signal is a level which must be true a minimum of 2US after the front edge of a FWDC or a REVC when a write mode is required. The front edge of the delayed FWDC or REVC is used to sample the WEC signal and set the transport to the write mode. If the read mode of operation is required, the WEC signal must be false for a minimum of 20US after the front edge of a FWDC or a REVC.

3.5.6 Write Data Lines (WDP, WD0-7 for 9-Channel; WDP, WD2-7 for 7-Channel)

These are levels which, when true, result in a flux transition (or logical "1") to be recorded at WRITE DATA STROBE (WDS) time. For recording to occur, the transport must be in the write mode of operation.

Data lines must be held steady for a period of 0.5US before and after the WDS pulse occurs.

3.5.7 Write Data Strobe (WDS)

This is a pulse of minimum width 2US, which is used as a clock to write data onto tape. One pulse is required for each character to be recorded. It is assumed that data lines have settled at least 0.5US before the trailing edge of this pulse occurs and will remain steady until 0.5US after the trailing edge of this pulse.

3.5.7.1 In 9-channel systems, an additional WDS pulse is required to write the Cyclic Redundancy Check Character (CRCC), four character spaces after the last data character.

3.5.8 Write Amplifier Reset (WARS)

This is a pulse of minimum width 2US which is used for writing the Longitudinal Redundancy Check Character (LRCC). In 7-track systems the front edge of the WARS pulse occurs, four character times after the trailing edge of the WDS associated with the last data character. In 9-track systems the front edge of the WARS pulse should occur eight character times after the WDS associated with the last data character.

3.5.9 Read Threshold (RTH)

This signal, used only in the 81 model transports (single gap-heads) selects one of two read amplifier threshold levels. A true level selects the higher threshold, while a false level selects the lower threshold. In the 82 model transports (read after write), the threshold level is automatically controlled by the write/read status of the transport. During writing the higher of the two levels is selected, while during reading the lower level is selected.

3.5.10 Off-Line (OFFC)

This is a level or pulse of minimum width 2US which causes the transport to be placed under manual control. An OFFC signal may be given during a rewind but it must be separated by at least 2US from a rewind command.

3.5.11 High Density Select (HDS) (Optional)

This is a level, used only in 7-track transports, whose true state causes the transport to operate in the higher density mode and causes the HI DEN indicator to be lighted.

3.6 INTERFACE OUTPUTS

The following is a description of the interface signals which are supplied from the transport to the customer controller. All names correspond to the true level of 0 volts. Barred terms correspond to a false level, which is between +2V and +5V. Interface outputs are gated with SELECT.

3.6.1 Ready (RDYI)

This is a level which is true only when all of the following conditions are true: tape tension is established, the initial load sequence has been completed, the transport is on-line, and no rewind is in progress.

3.6.2 Read Data (RDP, RD0-RD7, 9-Channel; RDP, RD2-RD7, 7-Channel)

These are the individual bits from each data channel assembled into one register. The data is ready to be sampled when the READ DATA STROBE occurs.

3.6.3 Read Data Strobe (RDS)

This is a pulse of minimum width 2US used to sample the read data lines. The trailing edge of the pulse should be used for sampling. The time between RDS pulses will vary considerably because of skew, bit crowding, and speed variations.

3.6.4 On-Line (OLI)

This is a level which is true when the transport is under remote control. When it is false, the transport is under local control.

3.6.5 Load Point (LDP)

This is a level which is true when the BOT tab is under the photosensor. The signal goes false after the tab leaves the photosensor area.

3.6.6 End Of Tape (EOT)

This is a level which, when true, indicates that the EOT tab is under the photosensor.

3.6.7 Rewinding (RWD)

This is a level which is true when the tape is rewinding or in the load sequence which follows rewinding.

3.6.8 File Protect (FPI)

This is a level which is true when power has been applied to the transport, and a reel of tape, without a write enable ring installed, has been installed on the transport.

3.6.9 High Density Indicator (HDI)

This is a level which is true whenever the high density mode has been selected. This selection may be accomplished by either an external HDS signal or the local HI DEN switch, depending on which option is selected.

3.7 INTERFACE TIMING

Figure 3-2 shows interface waveforms used for reading and writing.

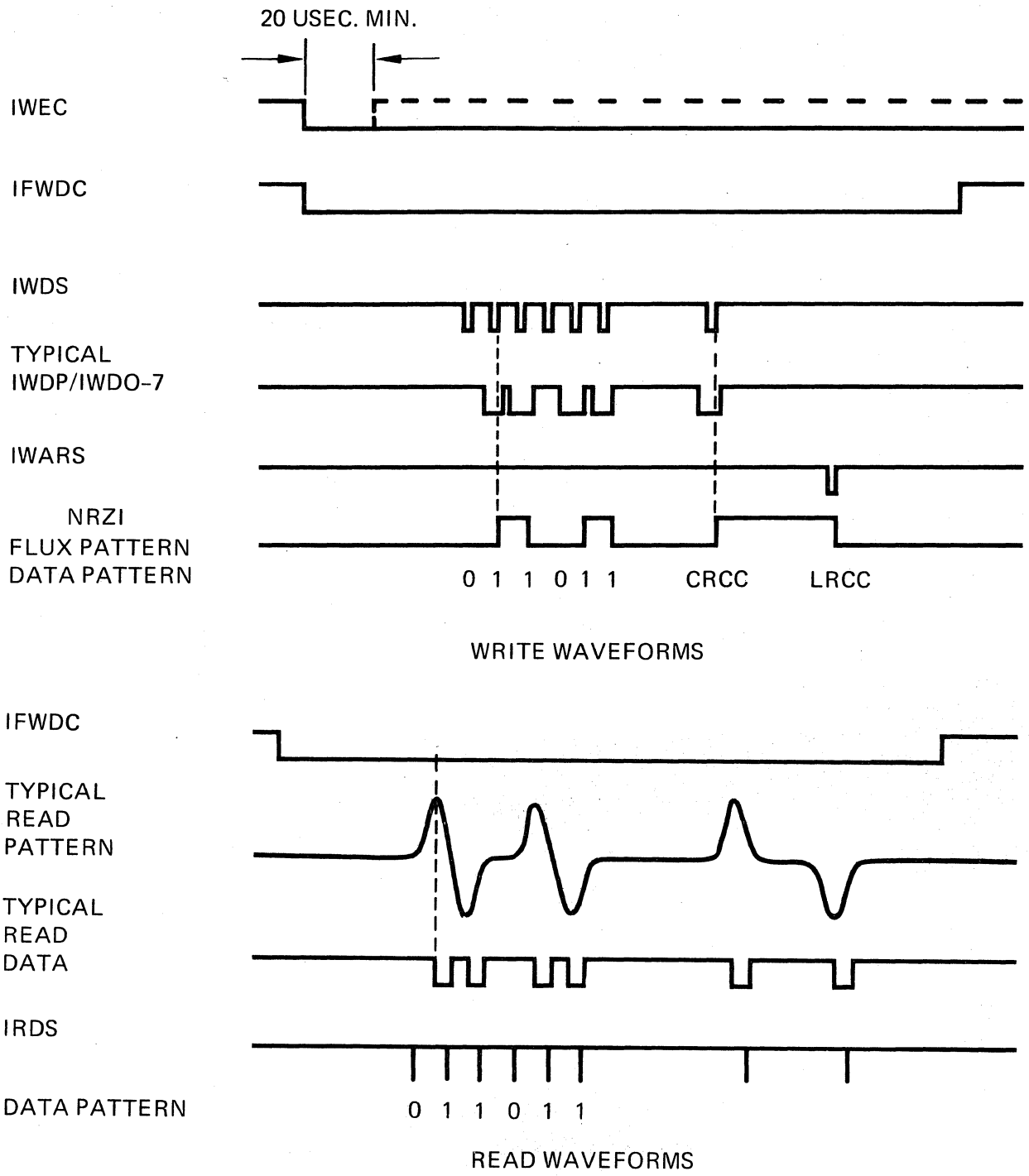

Figure 3-2. Waveforms For Reading And Writing

SECTION IV

THEORY OF OPERATION

4.1 INTRODUCTION

This section explains the operating theory of the various transport components. The transport is subdivided, for purposes of analysis, into the following subassemblies:

1. Control Logic
2. Power Supply
3. Capstan Drive, Tape Storage and Reel Servos
4. Data Electronics and Magnetic Read/Write Heads

4.1.1 Figure 4-1 shows the organization of the transport in terms of the two PC boards and the interconnected subassemblies. The first of the two PC boards contains the control logic, the capstan and reel servo amplifiers, the voltage regulators, the interlock relay, lamp drivers, and photo-tab sense amplifiers. Interconnecting plugs on the board connect the board circuitry with the control panel lamps and switches, the motors, the tension arm position sensors, the limit sensors, and the unregulated supplies. A printed circuit edge connector is used for transmitting control signals to and from the interface.

4.1.2 The second board, containing data electronics, is concerned only with reading and writing of data. Data to be written enters the board through one of two edge connectors. It is transmitted to the head through a connector or connectors located on the board. Data which is read from the tape and detected, is transmitted to the interface through a second edge connector.

4.1.3 DC power and certain control signals are transmitted between the boards. Both boards are individually hinged, greatly facilitating accessibility for service.

4.2 CONTROL LOGIC

This section describes the logical control circuitry which regulates tape motion. Operation of tape motion controls will be described by detailing the following operations: Bring-to-load point, tape motion commands after initial loading, rewind command, and unloading of tape. Frequent reference will be made to the Control Electronics schematics, located in the Appendix.

4.2.1 Bring-To-Load Point

The sequence of bringing to the load point will be considered both for the case when power is turned on with the tape loaded prior to the BOT tab, and with the tape loaded at some point after the BOT tab. The sequence for each case will be considered by detailing the logical operation occurring

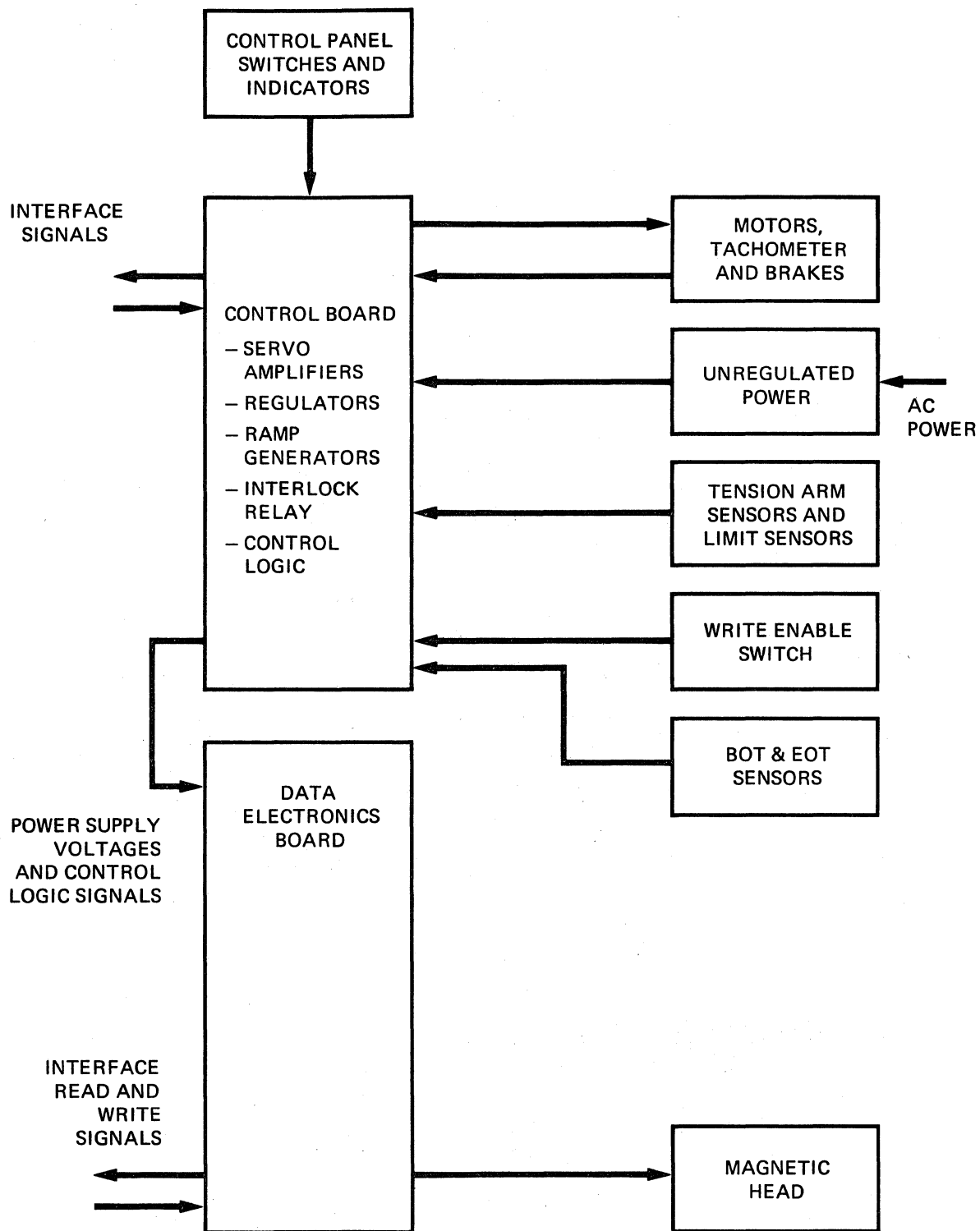

Figure 4-1. Organization Of The Transport

when each of the appropriate control switches is depressed. Figure 4-2 gives the load sequence waveforms.

4.2.1.1 Depress POWER Switch

Depressing the POWER switch applies AC line voltage to the power supplies. Power supply voltages are applied to all circuitry, but the interlock relay is not energized. Therefore the servo amplifiers are not connected to the motors. Consequently, at this point, no tape motion is possible.

4.2.1.2 Depress LOAD Switch The First Time

The normally open contact from the load switch is connected to the cathode of CR108. In this condition the base of Q109 is held at approximately +5V through R147 and K1-D, Q110 is held off, and relay K1 is not energized. When the LOAD switch is depressed, the base of Q109 is momentarily held at about one diode drop above ground, Q110 is turned on, and relay K1 and the brake solenoids are energized. Energizing K1-A, K1-B and K1-C causes the motors to be connected to the servo amplifiers. The tape is then given tension and the arms move into position. K1-D provides the interlock signal and write power.

4.2.1.2.1 If a write enable ring has been inserted in the supply reel, the write enable switch will be closed. Thus, when K1-D closes, +5V power is applied through R146 to the base of transistor Q108. This transistor energizes the write enable solenoid which holds the switch closed. This action results in WRT PWR being held high.

4.2.1.2.2 Right and left arm limit sensing is provided by two photoelectric transistors. When the arms are positioned, the photoelectric transistors are energized and present a low impedance to ground. Thus, the base of Q109 is held one diode drop above ground, and relay K1 is held energized, even though the cathode of CR108 was only momentarily grounded. If, at any time, either one of the arms should move outside the normal operating range so as to block light from its associated photoelectric transistor, relay K1 will be de-energized, thus removing power from the motors and applying the reel brakes.

4.2.1.3 Depress LOAD Switch A Second Time

Depressing the LOAD switch the first time does not effect the LOAD flip/flop U7B, because this flip/flop is held in the set condition until after relay K1 is energized. This set condition is a result of the signal NRESET (TP 56) being held low until INTERLOCK (TP 26) reaches a high level. Once relay K1 closes, INTERLOCK goes high, NRESET goes high and flip/flop U7B is no longer held in the set condition.

4.2.1.3.1 Depressing the LOAD switch the second time causes U7B to reset. This reset action means that the signal NLOAD goes low, which in turn forward biases diode CR101. This action enables the forward

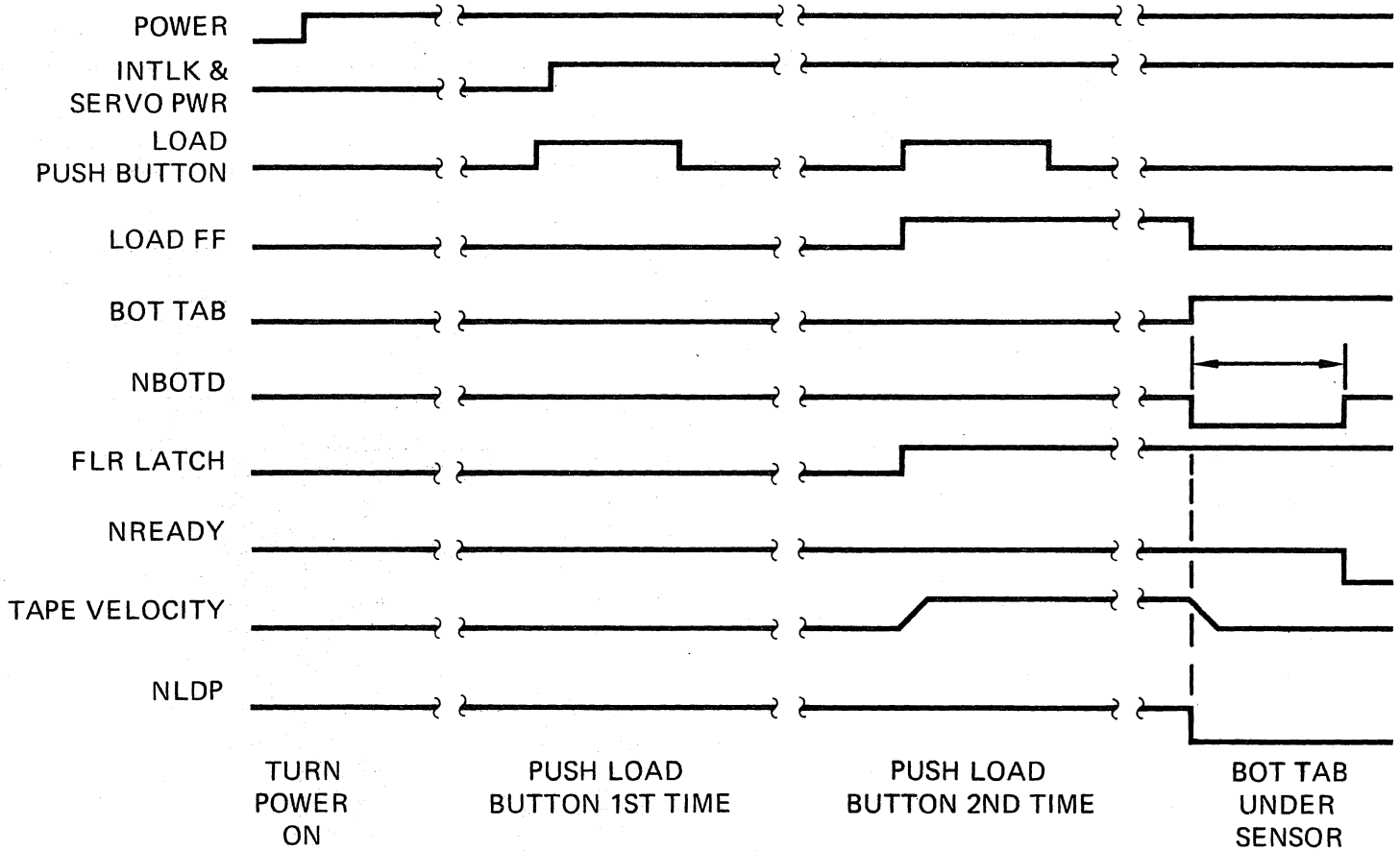

Figure 4-2. Load Sequence Waveforms

ramp generator which drives the capstan servo. If the tape is loaded at some point prior to BOT, it accelerates to its full speed and moves until it reaches the BOT sensor. When it reaches BOT, the BOT signal goes high. Hence, U6A pins 1, 2, 4 and 5 are all high, resulting in the LOAD flip/flop being set. This causes the tape to decelerate and come to rest under the BOT. If the tape was loaded at a point after BOT, depressing LOAD a second time will cause the tape to move forward and continue to move until physical end of tape is reached. It will not stop at EOT. To stop movement depress the reset button.

4.2.1.3.2 At this time U10A pins 3, 4 and 5 are all high (see remainder of section for explanation of why NBUSY AND FLR are high), causing NLDP to go low. This action causes the load lamp to be lighted. It will remain in a lighted condition until the tape moves away from BOT. The BOT tab is sensed by a photoelectric transistor whose output is transmitted through amplifier Q107 to a schmitt trigger, U20A. When BOT is reached, the signal BOT (U20 pin 13) goes high. This action triggers a 100MS one/shot, U20B. This signal, labeled NBOTD, returns to a low level at the end of the 100MS period, causing U14A pin 10 to go high. Thus, U14A pin 8, the NRDY signal, goes low as a result of all inputs to this gate being high. Later it will be shown that the NRDY signal is one part of the ROS level, which indicates when the transport is ready, on-line, and selected.

4.2.1.3.3 The FLR latch, formed by the gates U13A and U13B, is set when the LOAD flip/flop is reset. After the initial load sequence, the FLR signal will go high. The inverse signal, NFLR, is transmitted to U4D pin 12 and used to prevent the LOAD switch from having any further effect on operation.

4.2.2 Motion Commands After Initial Loading Of Tape

In this section the logical commands required to place the transport on-line and operate it from external commands will be discussed. In addition, a description will be given of operation of the transport off-line from the control panel switches.

4.2.2.1 Depress ON-LINE Control

If the ON-LINE switch is momentarily depressed, the on-line flip/flop, U16A is reset, causing the on-line indicator to be lighted. In this condition, the transport is on-line and therefore cannot be influenced by depressing any control panel motion command switches. To place the unit back in the off-line status, the RESET switch should be depressed. If jumper T is present, the unit may be placed on-line only after the load sequence has been completed (FLR is high).

4.2.2.1.1 The unit may be placed off-line by the signal OFFC, but may be placed on-line only by the control panel switch. If the OFFC signal is brought low, and if SEL is high (see section 4.2.2.2), then the ON-LINE flip/flop is set, and the unit is placed off-line.

4.2.2.2 The ROS Signal (Ready, On-Line, and Selected)

An important control signal in the unit is ROS, which indicates when the transport is ready, on-line, and selected. The signal formed at U3A pin 12 will go to a high level when RDY, OLN, and SEL are all at a high level. Operation of the OLN signal has been previously described. An explanation will now be given of the formation of the RDY and SEL terms.

4.2.2.2.1 The RDY signal gives an indication that the unit has gone through its load sequence and is not in the rewind mode. The inverse signal, NRDY, is formed at U14A pin 8 and goes low when all four inputs to the gate are high. The SEL and SELA signals may assume different states depending on the status of the ISEL and NOLN signals and which optional jumpers are used. If jumper W is present, SEL goes high if the unit is both selected and on-line. If jumper W is not present, SEL goes high when the unit is selected. When jumper V is used along with jumper W, both SEL and SELA go high when the unit is both selected and on-line. If jumper V is omitted, SELA is always high. The SELA signal is gated with all control signals which are transmitted external to the control board. Once the ROS signal has gone high, then the unit may receive external commands.

4.2.2.3 Operation From External Commands

If the ROS signal is high, the receipt of an external forward or reverse command (FWDC or REVC) will cause tape motion. In the case of a FWDC command, point (A) is brought low, thus starting the forward ramp generator. In the case of a REVC command, point (B) is brought high, thus enabling the reverse ramp generator. During reverse motion, the sensing of the BOT tab will cause reverse motion to stop. However, the NBOTD one/shot, U20B, will be triggered only if BOT is sensed during reverse motion. No automatic halt feature is provided when the EOT is sensed during forward motion. If it is desired to halt on EOT, the FWDC signal must be brought high by the controller when the IEOT signal goes low.

4.2.2.3.1 A forward or a reverse command will cause the MOTION signal (U4A pin 6) to go high. After a delay of approximately 10US, as determined by R107 and C101, U5A pin 8 goes high. This signal is differentiated by C102 and R108 and used to clock the write enable flip/flop, U7A. This flip/flop will be reset if the WRITE ENABLE COMMAND (IWEC) is low. Otherwise it will remain set. This flip/flop will remain set if the unit is not ready or not on-line, as controlled by U3C pin 4 and U3D pin 2.

4.2.2.3.2 Density selection is controlled by an external command or an external pushbutton, if included. For 9-channel transports there is one density, and therefore no selection is provided. In this case jumper U1-U2 is included, causing NHID to be permanently low and IHDI to be low when the transport is selected. For 7-channel transports two densities are available. For external density selection in these transports jumper U1-U3 is included, but jumper U1-U2 is omitted. As an alternative, high density selection may be performed with an alternate action pushbutton, in

which case jumper X is included and external selection through U1-U3 is usually omitted. Whenever NHID is low, the high density lamp is lighted.

4.2.2.3.3 If writing is to be performed, a write enable ring must be placed in the reel prior to placing it on the transport. With this ring in place, the signal WRT PWR goes high after the LOAD switch is depressed for the first time (see paragraph 4.2.1.2). With this signal high, U8D pin 10 is brought low, thus enabling the write enable lamp driver. In addition, the file protect signal (IFPI) goes high when the unit is selected.

4.2.2.4 Operation From The Control Panel

When the transport is placed in the off-line mode, it is ready to receive commands from the control panel switches. If the transport is both ready and off-line, U2A pin 5 is high. Depressing the FORWARD switch will cause U2A pin 6 to go low, provided that the unit is not at the end of tape (NEOT low), and it is not moving in the reverse direction (NREV low). When U2A pin 6 goes low, CR102 is forward biased and the forward ramp begins. In addition, U1A pin 12 goes low, thus causing the unit to latch up in the forward direction until EOT is sensed. Similarly, when the REVERSE switch is depressed, U2B pin 8 goes low and U1C pin 6 goes high. This action causes the reverse motion ramp to be energized. If the unit is in forward motion (NFWD low) or it is at the beginning of tape (NBOT low), reverse motion is halted.

4.2.3 Rewind Command

The rewind command will be considered, first for the case of the tape not at the load point and, secondly, for the tape at the load point.

4.2.3.1 Tape Not At The Load Point

When either an external or manual rewind command is given, the tape rewinds to the load point. It does so by moving backwards to the BOT tab at the rewind speed, overshooting the BOT, and then moving forward to the load point. Figure 4-3 shows the waveforms associated with this movement.

4.2.3.1.1 The rewind command causes the RWA output of flip/flop U11A to go high. This action causes the rewind ramp to begin. The rewind will continue until the BOT tab is encountered, causing RWB to go high and the one/shot, U20B, to fire.

4.2.3.1.2 Once the tape has overshoot BOT, and NBOT has gone low, the LOAD flip/flop will be reset from the clocking action of U4C pin 8. The LOAD signal going high causes the forward motion ramp generator to turn on. The tape then accelerates up to speed and moves until BOT is sensed again, the RWB and LOAD flip/flops are again set, and the 110MS BOTD one/shot fires. At the end of this 110MS period the NRDY signal will go low, indicating that the unit is again in a ready state.

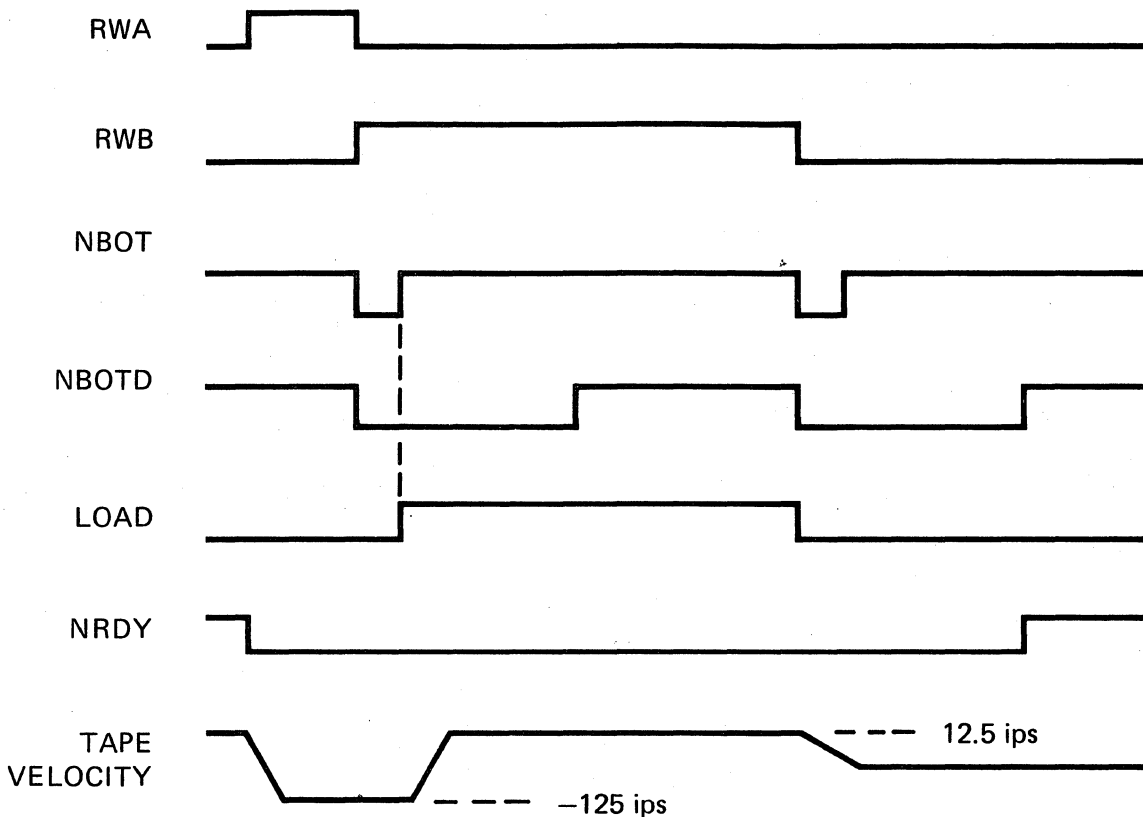

Figure 4-3. Waveforms For Rewind To Load Point

4.2.3.2 Tape At The Load Point - Unloading Of Tape

If the rewind switch is depressed when the tape is at the BOT point, it will begin the sequence just previously outlined. However, since BOT will not be encountered during rewind, neither RWB nor LOAD ever go high. Hence, the tape rewinds until tape tension is lost. An external rewind command will have no effect if the tape is already at BOT. Therefore, it is impossible to unload tape from an external command.

4.3 POWER SUPPLY

The power supply consists of two unregulated voltages, +14V and -14V, two regulated voltages, +5V and -5V, and an unregulated auxiliary voltage of approximately -15V. Depressing the POWER switch applies AC

power to the transformer primary and lights the neon lamp. The secondary voltage is rectified with bridge CR1 and filtered with C1 and C2 to form the two unregulated voltages. The auxiliary voltage is also unregulated and is formed with rectifiers CR10 and CR11 and capacitor C22. An auxiliary voltage is necessary so as to provide quick turn off for relay K1 and brakes 1 and 2 in the event of a power failure.

4.3.1 Regulator U21, used along with power transistor Q1, forms the +5V. The -5V source is derived from the +5V through op amp U22 and power transistors Q2 and Q21. SCR Q20 senses the +5V supply for over-voltage. If something should cause this voltage to increase to about +7.5V, the SCR will fire, thus shorting out the +14V supply until the fuse blows.

4.4 SERVO AMPLIFIERS AND TAPE STORAGE SYSTEM

In this section the capstan servo amplifier system and the reel servo amplifier system will be described.

4.4.1 Capstan Servo

The capstan servo amplifier consists of a motor tachometer combination along with an amplifier and ramp generators. Relay K1 is used to short across the motors in the event power is lost, providing dynamic braking.

4.4.1.1 The ramp generator consists of U23A, U23B, Q3, Q4, Q19 and associated circuitry. When point (A) is brought to 0V, transistor Q3 turns on, and U23B begins the forward motion ramp from 0 to -5V. Conversely, when point (B) is brought high, Q19 turns on, and U23B begins the reverse motion ramp from 0 to +5V. Potentiometer R19 controls the slope of the ramps, while potentiometer R53 balances the two ramps so that forward and reverse motion are equal.

4.4.1.2 The output of the ramp generator is brought through a voltage divider to the servo amplifier. It is summed with the tachometer feedback signal in operational amplifier U22A. Speed is controlled by potentiometer R21.

4.4.1.3 When a rewind command is given, point (C) is brought high, Q9 is turned off, Q10 is turned on, and the rewind ramp begins. The rewind voltage is transmitted from the emitter of Q10 to R30 and summed with the tachometer feedback in U22A. CR9, R52 and CR8 limit the maximum rewind speed to remain within the capability of the reel servos.

4.4.2 Reel Servos

Right and left reel servo amplifiers U24A and U24B are used to position the tension arms so as to maintain an approximately constant tape tension. These servo systems work by sensing tension arm angular position with a photosensitive potentiometer which produces a voltage output in ratio

to the arm position. The output of the sensors is amplified and drives the reel motors which in turn drive the left and right tape reels through pulleys. These reels cause the tape to tension such that the tension arm spring torque balances the reel motor torque when the arms are centered. During the fast rewind a compensating voltage is applied to U24A through R35 and R38 and to U24B through R42 and R46. This compensation helps keep the arms centered during the fast rewind.

4.4.2.1 Photoelectric transistors sense when tape tension is lost and cause relay K1 to be disabled. This action causes power to be removed from the motors and the brakes.

4.5 DATA ELECTRONICS

4.5.1 Introduction

Information is recorded in the Non Return to Zero mode. In this system a "1" on the information line causes a change in direction in the magnetization flux. Figure 3-2 indicates the waveforms which occur during writing and reading.

4.5.1.1 Since each "1" bit is recording as a flux transition and a "0" bit by no transition, the read electronics must determine when a flux change occurred. This determination is made by amplifying the read back signal and detecting where its peak occurred. When the read electronics has determined that a transition or no transition occurred for all channels, a strobe pulse is transmitted to the interface telling it to sample the data.

4.5.2 Data Recording

To record data a forward command (IFWDC) is first given in order to accelerate the tape to the prescribed velocity. In addition the write enable command (IWEC) input line must be true, the transport must be on-line, and the SELECT (ISEL) input line must be true. After a time determined by the inter-record gap, the WRITE DATA inputs and the WRITE DATA STROBE (WDS) are supplied to the data electronics.

4.5.2.1 The WDS signal is used to clock flip/flops whose J and K inputs are derived from the WRITE DATA signals. These signals cause the flip/flops to change state if the data is a "1" but remain in the previous state if the data input is a "0". These flip/flops then drive the write driver transistors.

4.5.2.2 At the end of each record, parity check characters have to be recorded and an inter-record gap inserted. Figure 4-4 shows the IBM inter-record gap format for 9 and 7 track systems. As is shown in this Figure, a 9-track system requires both a CRCC and a LRCC character. The CRCC is supplied by the customer interface and occurs 4 character times after the last data character. The LRCC, when required, occurs 4 character times after the CRCC and is derived by applying a WRITE

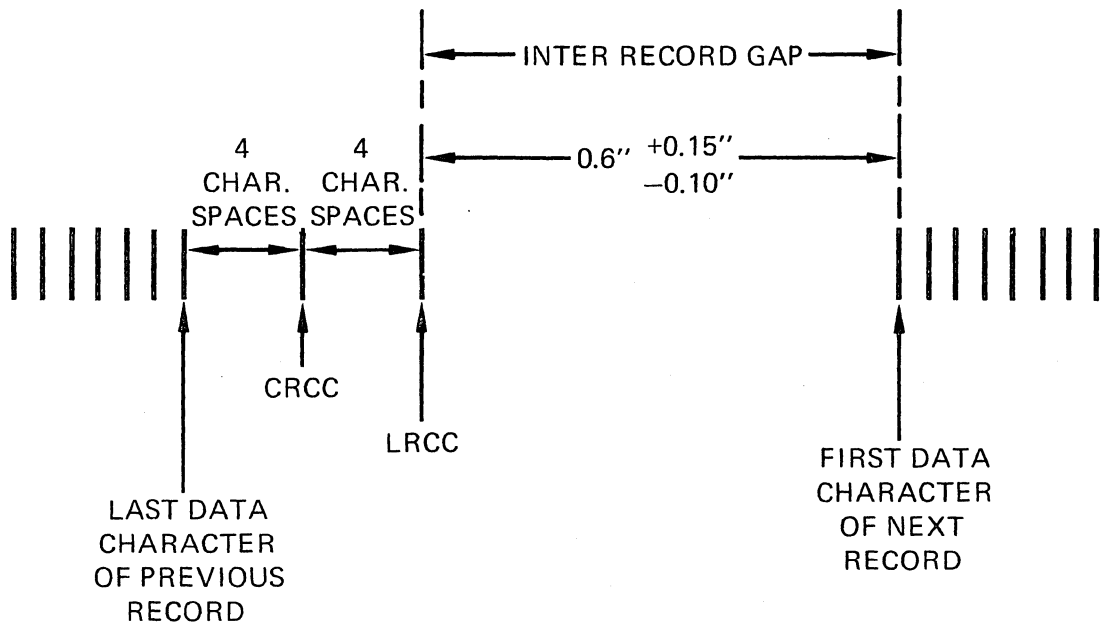

9-TRACK

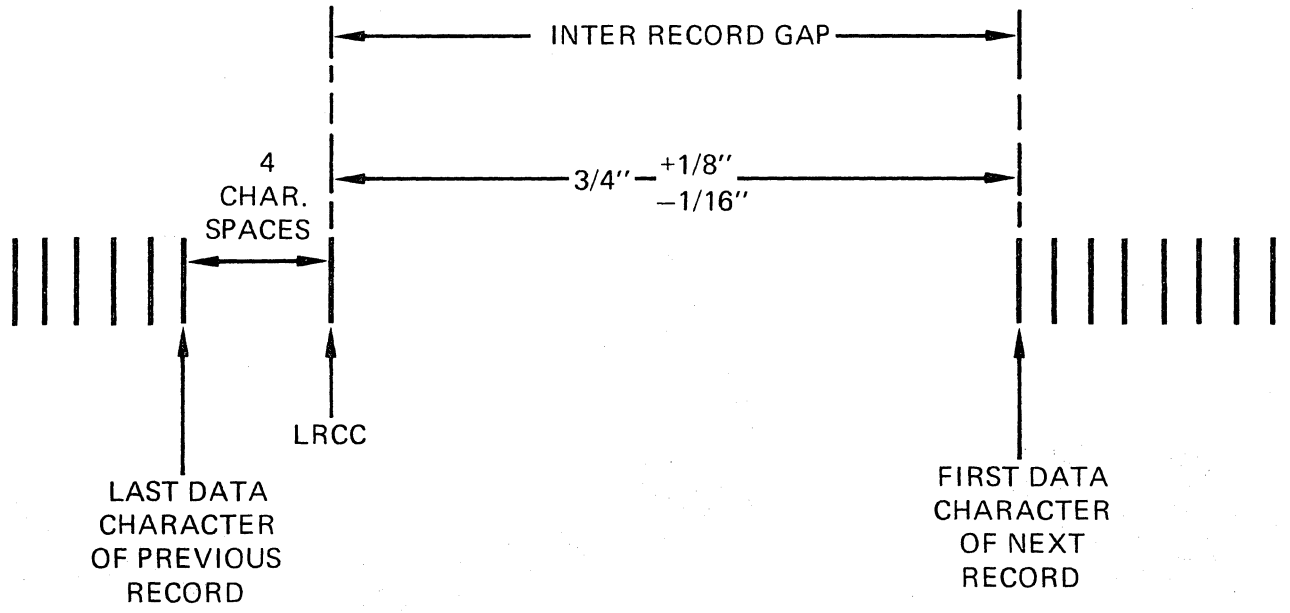

7-TRACK

Figure 4-4. Inter-Record Gap Format For 9 And 7 Tracks

AMPLIFIER RESET (IWARS) signal to the data electronics. This reset signal will cause all write flip/flops to reset. The result is that an LRCC signal will be written in such a way that the total number of flux transitions on any track is even.

4.5.2.3 After the LRCC has been written, the FWDC goes false and the tape decelerates to a stop. An inter-record gap will occur between the LRCC and the first character of the next block. This gap consists of the stop deceleration time, the start acceleration time for the succeeding record, and a time, T, determined by the interface. This time T is the delay between the FWDC going true and the first WDS.

4.5.2.4 If it is desired to separate files of information on tape, a File Gap is used. A file gap is a special character recorded followed by an LRCC. Figure 4-5 shows file mark recording for 9 and 7 track systems. To record a file mark, an FWDC is first given. After the tape is up to speed, a file mark is written, defined as follows: a file mark for a 7-track system consists of a "1" in data bits 4, 5, 6 and 7; a file mark for a 9-track system consists of a "1" mark in bits 3, 6 and 7. After the file mark is recorded, an LRCC is written 4 character times later in the 7 track system and 8 character times later in the 9 track system.

4.5.3 Circuit Description

The data electronics circuit description will be made with reference to Channel 1. Channels 2 through 9 are identical to number 1. Component designation refer to schematic 20-355 (20-182 for read after write version) shown in the Appendix.

4.5.3.1 Writing

Writing is performed by switching ON transistor 1Q1 or 1Q2, thus allowing current to flow in one half or the other half of the center tapped head winding. Write current magnitude is defined by 1R5 and 1R6.

4.5.3.1.1 Recording is performed in the NRZI mode. Thus, a 1 is recorded by changing the direction of current flow in the head winding. Flip/flop U12 enables write transistor 1Q1, or 1Q2, depending on whether the Q or \bar{Q} output of U12 is at the logical "0" level. For a logical "one" data input, the J and K inputs of U12 are held high, allowing the clock to switch the flip/flop to its opposite state. For a logical "zero" data input, the J and K inputs of U12 are held low, preventing U12 from changing state when a clock pulse arrives.

4.5.3.1.2 Clocking is accomplished by applying a WRITE DATA STROBE (IWDS) signal. The IWDS signal is inverted and transmitted to the clock inputs of all flip/flops. The data input signals come through the interface and are terminated by resistors 1R1 and 1R2. The data is inverted through U5 and transmitted to the J and K inputs of flip/flop U12.

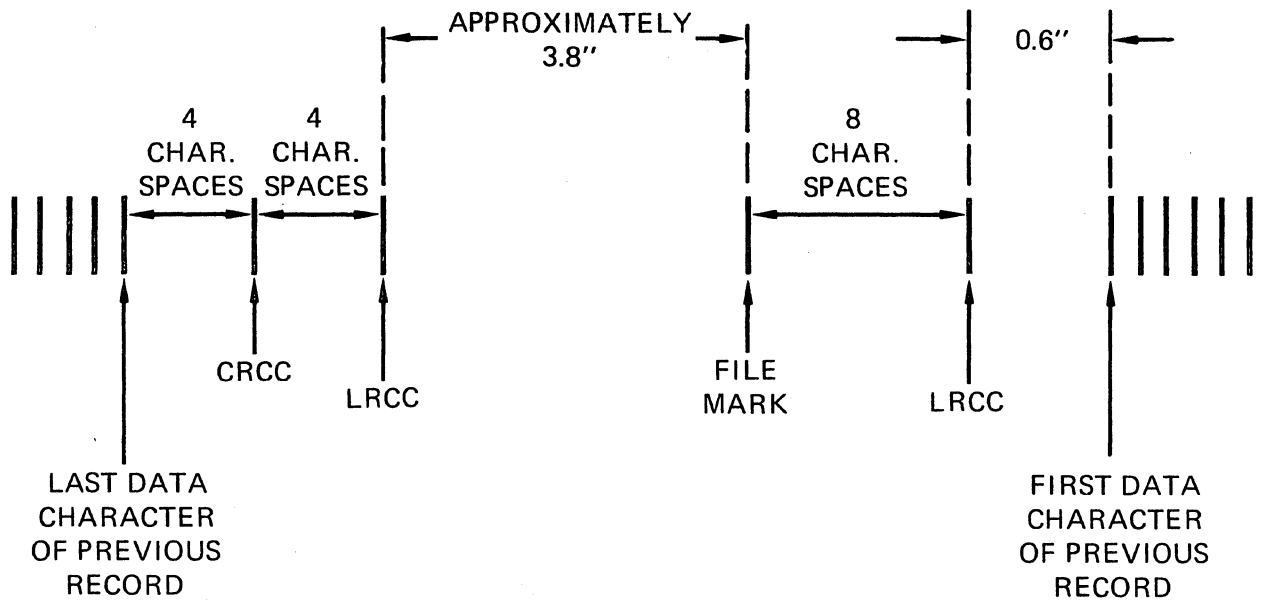

9-TRACK

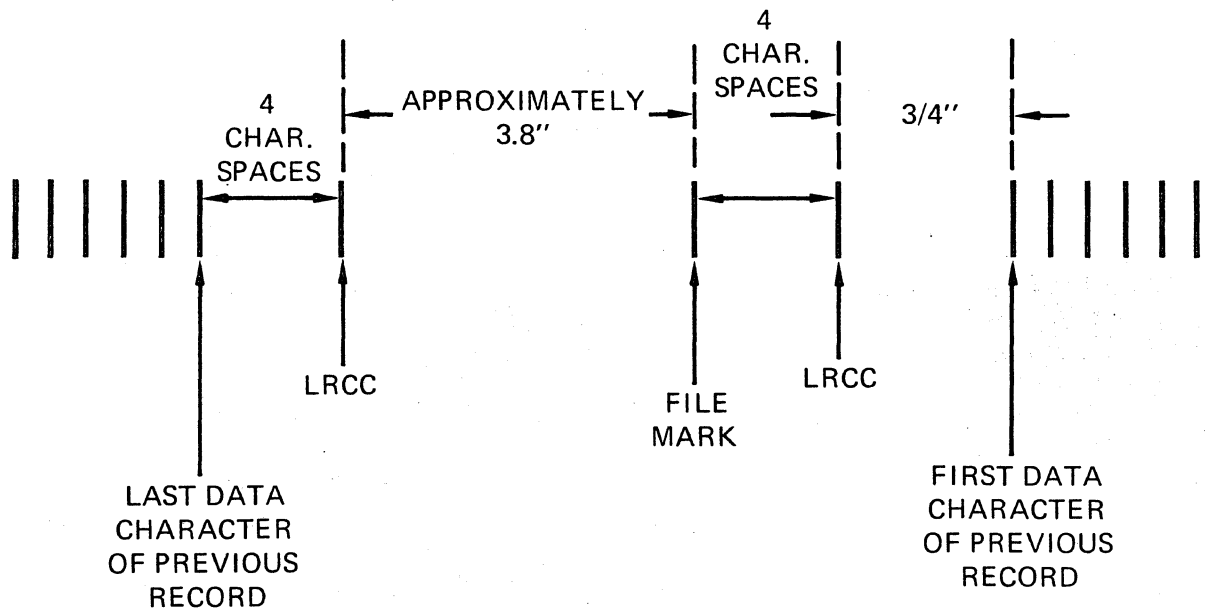

7-TRACK

Figure 4-5. File Gap Format For 9 And 7 Tracks

4.5.3.1.3 Certain control signals are used to enable writing. The NWRT signal enables and disables the write flip/flops. When NWRT is high, the set and clear inputs to the write flip/flops are held low. Thus both the Q and \bar{Q} outputs are held high, and therefore 1Q1 and 1Q2 are held OFF. Hence, no writing may be accomplished when NWRT is high. When NWRT is brought low, the set input to the flip/flops is brought high, while the clear input is brought high after a delay determined by R8 and C1. Thus, the flip/flops are left in the reset state. Lowering NWRT also turns ON transistor Q1, allowing erase current to flow.

4.5.3.1.4 Five volt power to write and erase is enabled by WRT POWER. To enable WRT POWER, a Write Enable ring must be installed in the reel. Without this ring, no power is available to allow write or erase current to flow in the drive transistors.

4.5.3.1.5 The MOTION signal prevents the write flip/flops from changing status unless the tape is in motion. When this signal is low, all flip/flops are held reset. However the erase transistors Q1 and 1Q2 may still be enabled. When MOTION is changed to a high level, normal writing may proceed.

4.5.3.1.6 The WRITE AMPLIFIER RESET signal (IWARS) is used to record the LRC character at the end of a record. During normal write operations the IWARS signal is held high. When this signal is switched low, all write flip/flops are reset, thus causing a "1" to be recorded in those channels whose flip/flops were set.

4.5.3.2 Reading

During reading the write and erase transistors are held OFF by the NWRT signal, as described previously. The read signal is therefore transmitted only to operational amplifier U17. Feedback resistors 1R9 and 1R10 along with 1R7 establish the gain of this amplifier at DC. This gain is such that, in the absence of an input signal, the output of U17 is held at approximately 0 volts. Capacitor 1C1 provides a low impedance shunt at the readback frequencies, so that the AC gain of U17 is determined by 1R11, 1R12, and 1R13 along with 1R7. Resistor 1R12 is a potentiometer which is adjusted so that the output of U17 is about 12V P-P during read back. Diodes 1CR1, 1CR2, 1CR3 and 1CR4 are used to prevent saturation of U17 during write operation. The read signal is too low a level to forward bias 1CR1 and 1CR2.

4.5.3.2.1 The output of U17 is transmitted to an inverter, U22. Full wave rectification is provided by 1CR5, 1CR6 and 1R17. The voltage at which the diodes conduct is controlled by the voltage appearing at the emitter of Q2. This voltage is set at one of two levels, depending on the logic state of IRTH. If IRTH is low, the emitter voltage of Q2 goes to a DC level of approximately 2.7V, or about 45% of the read signal peak; if IRTH is high, the emitter of Q2 goes to a DC level of approximately 1.4V, or about 24% of the read signal peak.

4.5.3.2.2 The rectified signal is transmitted to an emitter follower which drives a peak detector, U22. The peak detector is a differentiator whose output swing is limited by diodes 1CR7, 1CR8, 1CR9, and 1CR10. (When the incoming signal changes from positive to negative the output of the differentiator will swing from negative to positive.) This swing will cause transistor 1Q4 to saturate. The outputs of 1Q4 through 9Q4 are summed together through 100K resistors to a test point, TP8. Examination of TP8 gives some indication of the relative skew.

4.5.3.2.3 The negative going output from 1Q4 forms a clock pulse for U32. This clock pulse resets the flip/flop. The \bar{Q} output is inverted through U34 and is the output data to the interface.

4.5.3.2.4 The flip/flop Q outputs from all 9 channels are ORED together in gate U31. The first data bit to arrive resets its flip/flop which in turn causes the output of U31 to go high. The output U31 going high causes one one/shot U2 to trigger. When U2 times out, U32 resets, causing a 2US pulse to be generated by C5, R25, and R26. This pulse, the READ DATA STROBE (IRDS), indicates to the interface that the data is available to be sampled.

4.5.3.2.5 When U32 is reset, it not only generates the RDS signal as described previously, but a reset signal is also derived. U32 pin 8 going low causes U1 pin 8 to go high. A delay of greater than 2US is generated by R23 and C4, after which U34 pin 4 goes low. This action causes flip/flops U32, U33, U35, U37, and U38 to be set. The circuitry is now ready to receive the next set of data.

4.5.3.2.6 The duration of the one/shot time is determined by which of the two one/shots contained in integrated circuit U2 is selected. If a 9-channel transport is used, or if the higher density is selected in a 7-channel transport, timing is controlled by R30, R29, and C7. If the lower density in a 7-channel transport is chosen, R27, R28, and C6 determine the one/shot time.

4.5.3.2.7 The 7-channel version of this board is formed by omitting two of the nine channels.

4.5.4 Dual Gap Option

In the dual gap option a dual gap head is provided which has separate coils for reading and writing. When this type of head is selected, certain modifications to the data electronics are required.

4.5.4.1 The major change over the single gap case is the addition of deskew one/shots, U7 through U11. With the inclusion of these one/shots, the WRITE DATA STROBE (WDS) is no longer transmitted directly to the write flip/flop clock inputs. Instead, the WDS signal triggers the one/shots which in turn drive the clock inputs of the write flip/flops. Hence, a variable delay is provided which allows independent adjustment for each channel of the time between the WDS and the turn on of a write transistor. The method of adjusting these one/shots is included in Section V.

4.5.4.2 Two other important changes over the single gap case are included.

First, diodes 1CR1 - 9CR1, 1CR2 - 9CR2, 1CR3 - 9CR3, and 1CR4 - 9CR4 are no longer required. These diodes were protecting the read amplifier from write current transients. Secondly, the read threshold is no longer selected by external control. During writing, the high threshold is selected; during reading but not writing, the low threshold is selected. This is accomplished by the connection of U4 pin 6 to U42 pin 9.

SECTION V
MAINTENANCE

5.1 INTRODUCTION

This section contains information necessary to perform electrical and mechanical adjustments to the unit. Drawings necessary for electrical adjustment or troubleshooting are contained in the Appendix.

5.2 FUSE REPLACEMENT

Two fuses are mounted on the unregulated power supply cover. The line fuse is a 2.5A slow blow, while the 14V fuse is rated at 6A. An additional 6A fuse is used in the 18 Volt supply for the 25ips models.

5.3 TRANSPORT CLEANING

Clean the transport in the following five areas: the head and associated guides, the capstan, the roller guides, the take-up hub, and the tape cleaner. These areas of the unit are to be cleaned with a non-abrasive lint-free cloth or cotton. The cleaning agent must be XYLENE. As an alternate, isopropyl alcohol may be used.

5.3.1 The following precautionary notes must be observed when cleaning:

1. When cleaning the head or head guides do not use any rough or abrasive cloth. Do not use any cleaning agent other than XYLENE. Any other solvent, such as carbon tetrachloride may result in damage to head lamination adhesive.
2. The guides must not be soaked with excessive solvents. Excess solvent may reach the guide bearings, breaking down bearing lubricant.
3. Do not use excessive solvent on the take-up hub retention strip. Excessive solvent may damage the strip.

5.3.2 To clean the tape cleaner, remove the red plug from the front of the cleaner, clean with a cotton swab, and replace the red plug. To clean the capstan use a cotton swab moistened with XYLENE and remove all dirt and oxide. The roller guides are to be cleaned with a lint free cloth or cotton swab moistened in isopropyl alcohol. The guide surfaces must be cleaned so that all dirt and oxide are removed.

5.4 ELECTRICAL ADJUSTMENTS

The following adjustments refer to components shown on drawings 20-162 or 20-358 (20-182 for read after write version) and control schematic, located in the Appendix.

5.4.1 +5V Regulator

The +5 volts should be adjusted by using a very accurate voltmeter between TP5 and ground on the control board. Potentiometer R1 should be adjusted until the voltage reads 5.1 ± 0.05 volts. This voltage must be adjusted prior to making any speed adjustments.

5.4.2 -5V Regulator

The regulator tracks the +5V regulator but has no independent adjustment. To assure that this regulator is operating properly, place a voltmeter between TP7 and ground. This voltage should read $5.1 \pm 0.1V$. If it does not, and the +5V has been properly adjusted, the circuit should be examined for defective components.

5.4.3 BOT And EOT Amplifiers

When the tape is loaded, but neither the EOT nor the BOT tab is under its photo-sense, the voltages at TP73 (BOT) and TP71 (EOT) must read +3.0 volts minimum. This minimum level is set by adjusting R121 and R118, respectively. If either tab is under its particular photosense transistor, the voltage at its corresponding amplifier test point must read +0.4 volts maximum.

5.4.4 Ramp Timing

The ramp generator controls the acceleration and deceleration times for forward and reverse motion. Ramp timing is varied by adjusting R19 on the control board. To adjust this time, apply a low frequency (5Hz) squarewave to the FWDC input. Observe the ramp time at TP11 and adjust R19 until the time is 28MS. Once this pot is set, and tape speed has been noted, both the rise and fall ramps for FWDC and REVC should be approximately equal.

5.4.5 Tape Speed

Two potentiometers are used for controlling tape speed. The first, R21, controls the absolute tape speed; the second pot, R53, controls the balance between forward and reverse speeds.

5.4.5.1 To adjust speed, load the transport with an all "1's" master tape. Connect an electronic counter to any of the data channels (1TP6 - 9TP6).

5.4.5.2 An iterative process is used for adjusting forward and reverse speeds. First, run the transport in the forward direction with the master tape, and adjust R21 until the counter reads the specified frequency (e. g., 10KHz for 800BPI and 12.5ips). Next, run the tape in the reverse direction and record the frequency, Fr. Take the difference, f between this recorded frequency and the specified frequency. Adjust R53 until the reverse

frequency is X^* . Repeat the entire process by again adjusting the forward speed for the specified frequency and again adjusting the reverse speed for X^* . After two to three repetitions of this process, the speed should be within the required accuracy.

5.4.5.3 A rough estimate of forward and reverse speeds may be obtained by placing the unit under a fluorescent light and observing the strobe disk which is mounted on the capstan cover. The spokes of the strobe disk should have approximately equal movement in the forward and the reverse direction.

5.4.6 Read Amplifier Gain

The read amplifiers on the data board are each independently adjusted by means of the single turn pots 1R12 through 9R12. The gain should be adjusted by using an all "1's" tape, previously recorded on the unit to be adjusted. Adjust each of the amplifiers so that the output is an approximately sinusoidal voltage of magnitude 12 ± 0.25 volts peak-to-peak.

5.4.7 Read Data Strobe Adjustment

To adjust the read data strobe read a tape which has been recorded at the lowest density available on that transport. The time between the occurrence of the first channel of data information and the read data strobe is adjusted by use of potentiometers R30 and R28. To make this adjustment place the trigger channel of a dual trace scope at TP14 and monitor TP10. For a 9-channel transport adjust the delay between the voltage going high at TP14 and the end of the read strobe at TP12 (positive going edge) using R20.

5.4.7.1 For a 7-channel transport first select the higher of the two densities and adjust the delay time using R30 and then select the lower of the two densities and adjust its delay time using R28. These delay times should be measured as described previously and have a value given in US by T^{**} .

5.4.8 Write One/Shot Adjustments (Performed After 5.5.1)

The write one/shots, used only on the read after write units, are used to compensate for skew introduced due to writing.

$$*X = Fr + \frac{f}{2}$$

$$**T = \frac{10^6}{2SD}$$

where D is the recording density in bits per inch,
and S is the speed in inches per second.

5.4.8.1 To adjust these one/shots first adjust all write one/shot potentiometers 1R27 through 9R27, to minimum resistance. Secondly, determine during read which channel arrives first. To make this determination, place one channel of a dual trace oscilloscope at TP14. Place the second channel of the oscilloscope successively at 1TP5 through 9TP5. Measure the time difference between the two traces of the oscilloscope to determine which channel consistently arrives first. After this measurement has been made, the write one/shot associated with the channel which arrives first should not be moved during succeeding adjustments.

5.4.8.2 The adjustments of the other channels is performed by observing the skew waveform at TP8. The waveform will roughly approximate that shown in the lower part of Figure 5-1. While the transport is both reading and writing, adjust the one/shot pots, 1R27 through 9R27, to try and make the waveform at TP8 approximate that shown at the top portion of Figure 5-1.

5.5 MECHANICAL ADJUSTMENTS

5.5.1 Read Skew Adjustments

This adjustment is not required unless a head is replaced or damage to the head has occurred. Under these circumstances the procedure outlined below should be followed. First, an 800BPI master tape should be loaded on the transport, and the unit should be given a forward command. The read skew waveform at TP8 should be observed with an oscilloscope. If read skew compensation is required, the waveform will appear similar to that shown in Figure 5-1A. A properly adjusted unit will have a 5 volt to 0 volt fall time of less than 14MS for the 12.5ips transport.

5.5.1.1 Move the tape off of the head guide cap toward the spring loaded guide ring first on the right hand guide and secondly on the left hand guide. If moving the tape on the left hand improved the skew, the right hand guide should be shimmed out, and vice versa.

5.5.1.2 To insert the shims first remove the guide retaining screw and remove the guide. Place onto the screw the proper number of one-half of a thousandth (WL Part No. 00-082) shims. The proper number of shims is calculated as follows: Determine the spacing between characters on the tape according to the expression,

$$S = \frac{1}{\text{Density}}$$

5.5.1.3 For example, the spacing at 800BPI is 1250Uinches. If, as an example, skew measurements at TP8 show the magnitude of skew to be 1/6th of the period of the waveform, then the skew is approximately 208US. A ratio of about 10 to 1 should be used in determining the number of shims to be used at the guides. Thus, in the above example, shimming should move

the guide 2080Uinches, or 5 500-Uinch shims should be used. Note that these calculations are approximate because of the difference in distance between the right guide and the head and the left guide and the head. A certain amount of experimentation is required to arrive at the final number of shims required.

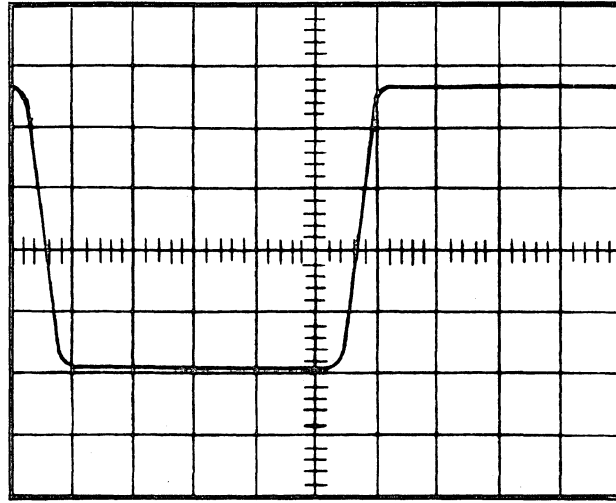

(A) IDEAL SKEW WAVEFORM

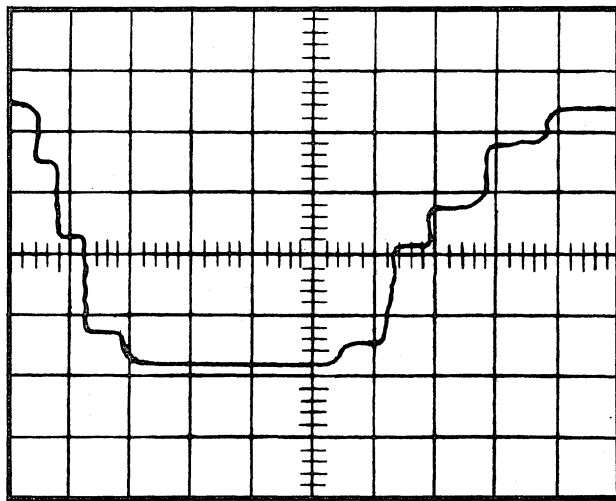

(B) POOR SKEW WAVEFORM

Figure 5-1. Skew Waveforms

5.5.2 Replacement Of The Precision Magnetic Head And Drive Assembly

The magnetic head requires replacement if it or the cable is defective or if the head has worn considerably. As a rule of thumb, head wear is considered excessive if the worn section of the head crown is greater than 0.010 inch below the unworn section. Also, the head should be replaced if deep grooves appear on the crown of the head.

5.5.2.1 The entire precision magnetic head and drive assembly may be replaced easily without any requirement for head deskew adjustments. To replace this assembly first remove the head connector and cable clamp from the data electronics board. Remove the three cap screws holding the precision plate to the mounting plate. Remove the precision plate, while carefully bringing the head through the hole in the mounting plate. Position the new precision plate and head assembly in place and replace the three cap screws. The head will now be in correct position with no further mechanical adjustments required.

5.5.2.2 As an alternative, the head itself may be replaced, thus requiring shimming for deskew adjustment. To replace the head, remove the head cover if supplied, and unplug the cable connector from the data board. Disconnect the cable clamp. Next remove the screws that hold the head in place and bring the connector through the hole in the mounting plate. Bring the connector of the new cable through the same hole and attach it to its mating section, on the data board. Fasten the new head in place with two mounting screws. Attach the cable clamp.

5.5.3 Reel Servo Belt Tension

The belts which connect the reel hubs to the servo motors must be adjusted to a proper tension. This tension must be sufficient to prevent belt teeth from skipping but not so great that overloading occurs.

5.5.3.1 Measure tension by deflecting the belt midway between the motor shaft and the reel hub with a force of approximately 7 oz. This deflection may be performed by pushing on the belt with a force gauge. Measure the distance that the belt deflects from its rest position. This distance must be approximately 0.30".

5.5.4 Tape Tension

Tape tension is measured at each of the arms with a force gauge. This tension must measure $8 \pm 1/4$ oz. If it does not, loosen the cap screw which holds the angle bracket that is providing spring tension. Rotate the angle bracket until the force reads 8 oz. on the gauge and retighten the screw. Refer to Figure 5-2 for proper measurement of tape tension.

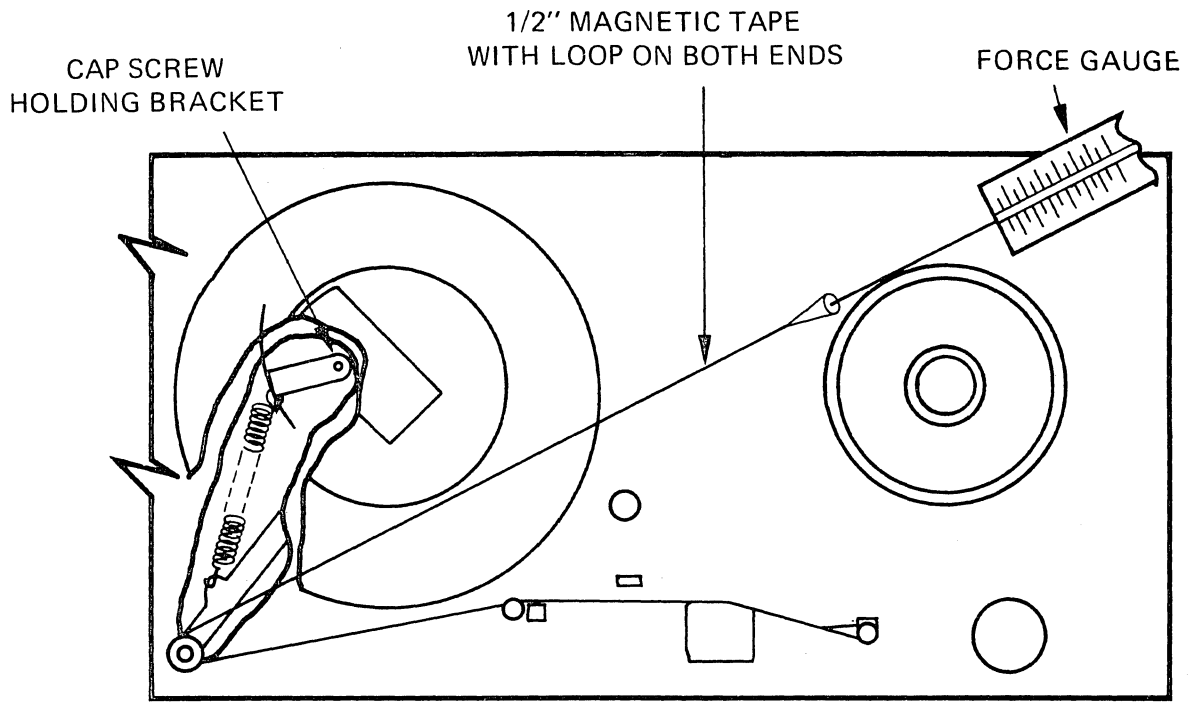

(A) SUPPLY REEL

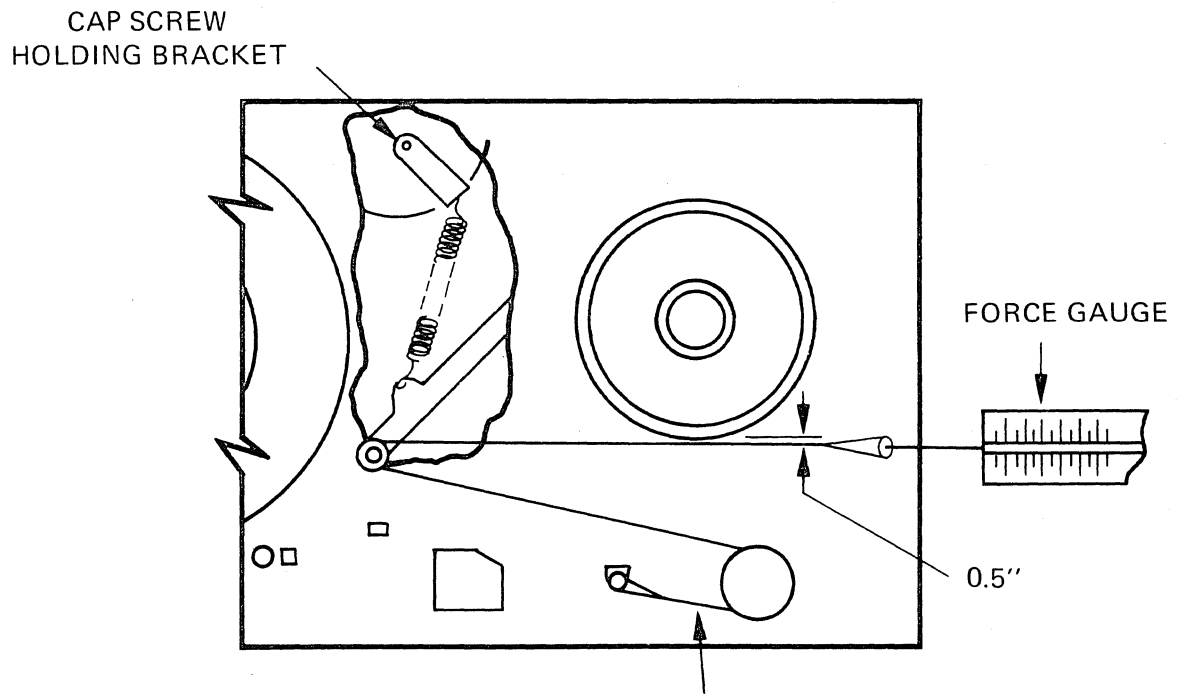

(B) TAKE-UP REEL

Figure 5-2. Tape Tension Adjustment

5.5.5 Reel Brake Adjustment

The reel brakes must be adjusted so as to provide a minimum of movement upon release. Begin this adjustment by depressing the POWER switch and depressing the LOAD switch once. This action causes the reel brake solenoids to be energized. In this position each of the brake shoes must be in close proximity to the metal washer bonded on the belt pulley but must not be touching. If the shoes and washer are too close, rubbing will occur during tape movement; if they are too far apart, the braking action will take too long, resulting in tape spillage. (Clearance should be .010 to .020".)

5.5.5.1 If it appears that the brakes are not properly adjusted loosen the two cap screws which hold the solenoid for the respective brake, that needs adjustment, and move the solenoid slightly inward or outward as required. Tighten screws and test the transport to ensure proper adjustment has been obtained.

5.5.6 Roller Guide Adjustment

Take up roller guide controls tape movement on and off of the capstan. It requires adjustment only under unusual circumstances, such as when the motor assembly is changed. To perform this adjustment, cycle the transport with an external controller so that the unit moves repeatedly forward and then reverse. Observe the spacing between the outer edge of the capstan and the edge of the tape. If this distance is quite different when the tape moves forward from the distance observed when the tape moves in reverse, then an adjustment of the take up roller guide is required. This adjustment is performed by shimming in or out the roller guide until the distance specified above is approximately equal in the forward and reverse direction. The shims are inserted by removing the cap screw holding the guide, inserting or deleting shims (use WL Part No. 00-083) and then replacing the guide and screw. A certain amount of experimentation is required to determine the exact number of shims required. If no shims are available the entire arm may be moved in or out by loosening the screw holding the arm to the shaft. Care must be exercised to avoid rotating arm with respect to the shaft.

5.5.7 Write Enable Solenoid Assembly Adjustment

The write enable solenoid assembly is designed to detect the presence of a write enable ring in the tape reel. A spring mounted pin extruding through a hole in the mounting surface is pushed back through its hole by the write enable ring. When it is pushed back, this pin causes normally open contacts of the write enable switch to close. After the LOAD switch is depressed for the first time, the write enable solenoid latches the write enable switch close, causing the pin to retract even further. If no write enable ring is present, the pin remains extruding through the hole in the mounting surface. Adjustments should ensure that first, if no write enable ring is present, the pin does not rub against the reel; and secondly, if a write enable ring is present, the pin retracts to its proper position.

5.5.7.1 Begin the adjustment by measuring the distance that the pin extrudes above the tape reel mounting surface of the reel hold down assembly. This distance must be 0.06". If it is not, adjust the pin locking nut until the proper distance is obtained. The second adjustment involves proper positioning of the write enable solenoid on the mounting bracket. This adjustment must be performed if it is determined that pin retraction is either too far or not far enough. To move the position of the solenoid, use an angle wrench to loosen the two cap screws holding the solenoid to its bracket. When energized, the distance between the plunger nut and the rear of the mounting plate shall be 0.13 ± 0.01 ". Retighten the cap screws.

5.5.8 Arm Limit Rubber Bumpers

Rubber bumpers are provided to cushion the tension arms when they move to their limits. Without these rubber bumpers the tension arms would hit against the mounting frame when tape tension is lost.

5.5.8.1 These bumpers must be examined periodically to determine if they have worn excessively. If so, they should be either rotated or changed. Rotation involves simply loosening the screw that holds the bumper in place, rotating it until the worn section is not facing the arm, and retightening the screw. To replace the bumper, remove the screw, washers and spacer and replace with a new bumper (WL Part No. 00-074).



APPENDIX A

WILLARD LABS. INC.

BILL OF MATERIAL

TITLE TRANSPORT ASSY. MOD. 89081S.				B/M NO. 20-340	
COMPILED BY: DATE		CHECKED BY: DATE		APPROVED BY: DATE	
S. LEE 11/30/71				RELEASE/CHANGE DATE ISSUE	
NEXT ASSY.		IST USED ON		DWG. SIZE	
				SHEET <u>1</u> OF <u>1</u>	
PART NO.	DESCRIPTION	QTY.	CODE	REMARKS	
1 20-320	TRANSPORT ASSY-BASIC	1	A	SEE ITEM 7	
2 20-346	ELECTRONICS CONTROL ASSY	1	A	9 TRACK WITH PWR FAIL OPTION	
3 20-355	PCB ASSY- DATA "A"	1	A	20-160 MAY BE USED	
4 20-364	WRITE ENABLE SW. ASSY	1	A		
5 20-246	MAG. HEAD & DRIVE ASSY	1	A		
6 20-337	CONTROL PANEL ASSY	1	A	NO PWR & HI DENS. SW.	
7 20-341	POWER SUPPLY ASSY	1	A	REPLACES 20-118 OF ASSY 20-320	
8 20-342	HARNESS ASSY	1	A		
9 20-309	PCB ASSY-PWR FAIL RESTART	1	A		
10					
11					
12					
13					
14					
15					
16					
17					
18					
19					
20					
21					
22					
23					
24					
25					

CODE: D - DETAIL PART WITH NO B/M A - ASSY. WITH B/M
 R - REFERENCE DOC. S - SHIP SEPARATE

WILLARD LABS. INC.

BILL OF MATERIAL

TITLE TRANSPORT ASSY. MOD. 87581S			B/M NO. 20-370				
COMPILED BY: S. LEE	DATE: 2/18/72	CHECKED BY:	DATE:	APPROVED BY:	DATE:	RELEASE/CHANGE DATE	ISSUE
NEXT ASSY.		IST USED ON		DWG. SIZE	SHEET 1 OF 1		

PART NO.	DESCRIPTION	QTY.	CODE	REMARKS
1 20-320	TRANSPORT ASSY-BASIC	1	A	SEE ITEM 7
2 20-333	ELECTRONICS CONTROL ASSY	1	A	7 TRACK WITH PWR FAIL OPTION
3 20-355	PCB ASSY- DATA "A"	1	A	20-160 MAY BE USED
4 20-36 ^b	WRITE ENABLE SW. ASSY	1	A	
5 20-244	MAG. HEAD & DRIVE ASSY	1	A	
6 20-337	CONTROL PANEL ASSY	1	A	NO PWR & HI DENS. SW.
7 20-341	POWER SUPPLY ASSY	1	A	REPLACES 20-118 OF ASSY 20-320
8 20-342	HARNESS ASSY	1	A	
9 20-309	PCB ASSY-PWR FAIL RESTART	1	A	
10 20-368	CONNECTOR-HI&LO DENS SWITCHING	1	A	
11				
12				
13				
14				
15				
16				
17				
18				
19				
20				
21				
22				
23				
24				
25				

CODE: D- DETAIL PART WITH NO B/M A- ASSY. WITH B/M
 R- REFERENCE DOC. S- SHIP SEPARATE

SPARE PARTS LIST

PART NO.	ITEM
20-375	Tape Guide Assembly
20-141	Photo Sense Assembly
20-106	Position Sensor Assembly
20-111	Roller Guide Assembly
20-140	Capstan
20-131	Tape Cleaner Assembly
20-331	Door Assembly
20-194	Write Enable Switch
00-167	Belt Pulley
	Magnetic Head
00-001	9-Track Single Stack R/W/E
00-007	9-Track Dual Stack R/W/E
00-008	7-Track Dual Stack R/W/E
00-009	7-Track Single Stack R/W/E
	Control Panel Assembly
00-101	Power Switch, PB
00-102	Load Switch, PB
00-103	Rewind Switch, PB
00-104	On-Line Switch, PB
00-105	WRT EN Switch, PB
00-106	HI DENS Switch, PB
00-107	Forward Switch, PB
00-108	Reverse Switch, PB
00-109	Reset Switch, PB
20-355	PCB Assembly Data A (Replaces 20-160)
20-341	Power Supply Assembly
	Electronic Control Assembly
20-333	For 7-Track Dual Density (Model 87581S)
20-346	For 9-Track (Model 89081S)
	NOTE: 20-333 and 20-346 differ in jumper installation only. (See schematic diagram 20-163.)
20-244	Magnetic Head and Tape Drive Assembly 7-Track, Single Gap
20-247	Magnetic Head and Tape Drive Assembly 9-Track, Dual Gap
20-309	PCB Assembly - Power Fail Restart

PART NUMBER CROSS REFERENCE

WILLARD LABS. PART NUMBER	MANUFACTURER (OR EQUIVALENT)	DESCRIPTION OR PART NUMBER
Capacitors, Disc		
00-136	Sprague	Series 5GA $\pm 20\%$, 500V
00-189	Sprague	Series TG $\pm 20\%$, 100V
Capacitors, Electrolytic		
00-052	STM	21C 15HC223, 22000UF, 15VDC
00-053	Sprague	TL, 39D, 601D, 1000UF, 25VDC
00-137	Sprague	500D, 6VDC
00-138	Cornell-Dubilier	Type NLW, 12VDC
Capacitors, Mylar Film		
00-139	Temple	Type FU $\pm 10\%$, 50VDC
00-140	Temple	Type FU $\pm 10\%$, 100VDC
Capacitors, Solid-Tantalum		
00-145	Kemet	Series E $\pm 20\%$, 10VDC
00-146	Kemet	Series E $\pm 20\%$, 15VDC
00-147	Kemet	Series E $\pm 20\%$, 20VDC
Diodes		
00-021	GE	1N4154, Silicon
Diodes, Rectifier		
00-051 ρ	Motorola	MDA 952-1
00-045	Motorola	1N4001
00-185	Motorola	1N4720 (plastic case)
Diodes, Zener		
00-046	Motorola	1N5225, 3.0V $\pm 10\%$, .5W
00-047	Motorola	1N5231, 5.1V $\pm 10\%$, .5W
00-048	Motorola	1N5235, 6.8V $\pm 10\%$, .5W
00-173	Motorola	1N5239, 9.1V $\pm 10\%$, 15W

PART NUMBER CROSS REFERENCE (Continued)

WILLARD LABS. PART NUMBER	MANUFACTURER (OR EQUIVALENT)	DESCRIPTION OR PART NUMBER
IC'S		
00-010	T. I.	SN7476N, TTL, Dual FF
00-011	Motorola	MC853P, DTL, Dual J-K FF
00-012	Motorola	MC836P, Hex Inverter
00-013	Motorola	MC844P, DTL, Dual 4-In
		Power AND Gates
00-014	Motorola	MC437P, Dual Op Ampl.
00-015	Motorola	MC862P, DTL, Triple 3-In
		AND Gates
00-016	T. I.	SN7416N, Hex Inverter
		Buffers/Drivers
00-017	T. I.	SN74123N, Dual One/Shot
00-018	Signetics	N5558V, Dual Op Ampl.
00-036	Motorola	MC846P, DTL, Quad, 2-In
		AND Gates
00-037	Motorola	MC830P, DTL, Dual 4-In
		AND Gates
00-038	Motorola	MC858P, DTL, Quad, 2-In
		AND Power Gates
00-039	Fairchild	UA723C, Voltage Regulator
		Dip.
00-180	Motorola	MC856P, DTL, Dual J-K FF
Relay		
00-034	Potter Brumfield	R10-E1-X4-V185-12VDC. 4
		Pole, Form C, 5 Amp, 12VDC,
		185 Ohm, Plug-In
Resistor, Carbon		
Composition		
00-026	Allen-Bradley	RC07 ±5%, 1/4W
Resistor, Metal		
Film		
00-022	Corning	RN60D ±1%, 1/4W
Resistor, Variable		
Multi-Turn		
00-024	Spectrol	41-2-1-XXX, Cermet 15 turn

PART NUMBER CROSS REFERENCE (Continued)

WILLARD LABS. PART NUMBER	MANUFACTURER (OR EQUIVALENT)	DESCRIPTION OR PART NUMBER
Single Turn		
00-023	Spectorl	53-1-1-XXX, Cermet
Transistors		
00-019	Motorola	2N4123. Si., NPN
00-020	Motorola	2N4125. Si., PNP
00-040	Motorola	MJE1090. PNP Power Darlington
00-041	Motorola	2N3053. Si., NPN Power, TO-5 Case
00-042	RCA	2N4037. Si., PNP Power, TO-5 Case
00-043	Motorola	2N3055. Si., NPN Power, TO-3 Case
00-044	Motorola	MJE3055. Si., NPN Power, Plastic
00-049	Motorola	2N4441, Plastic, Silicon Controlled Rectifier
00-164	RCA	2N5323, Si., PNP
Fuses		
00-084	Bussman or	3AG - Slo Blow
00-085	Little Fuse	3AG - Fast Blow

PARTS LIST FOR POWER SUPPLY ASSEMBLY 20-118, 20-341

REFERENCE DESIGNATION	PART NUMBER
C1, C2	00-52-22000
C22	00-53-1000
CR1	00-051
CR10, CR11	00-185
F1	00-084-2.5A
F2	00-085-6A
T1	00-002

PARTS LIST FOR PCB ASSEMBLY CONTROL 20-163L

REFERENCE DESIGNATION	PART NUMBER
C3, C21, C23	00-136-100PF
C4, C5	00-138-100MF
C6, C16, C17, C107 - C116	00-146-3.3MF
C7	00-139-.22MF
C8, C9, C18, C19	00-147-6.8MF
C10	00-140-.047MF
C11, C106	00-145-22MF
C12 - C15	00-145-4.7MF
C21, C23, C117, C118, C119, C120	00-136-750PF
C24	00-189-.005MF
C20, C102	00-140-.022MF
C101	00-140-.01MF
C103, C104	00-140-.001MF
C105	00-145-10MF
CR2	00-048
CR3 - CR8, CR101 - CR104, CR106 - CR108	00-021
CR9	00-047
CR105, CR109	00-045
CR110	00-046
K1	00-034
Q1, Q7, Q8, Q12, Q18	00-043
Q2, Q14, Q16	00-044
Q3, Q19, Q101 - Q105	00-020
Q4, Q9, Q10, Q106, Q107, Q109	00-019
Q5, Q11, Q15, Q108	00-041
Q6, Q13, Q21	00-042
Q17	00-164
Q20	00-049
Q110	00-040
R1, R118, R121	00-024-5K
R3, R5, R13, R14, R15, R24	00-022-10K
R4	00-026-47
R6, R27, R28, R40, R41, R48, R49, R50	00-026-100
R7, R9, R10, R12, R52, R120, R123, R149	00-026-1K
R8, R11, R18, R29	00-026-2K
R16, R33	00-026-3.3K
R17, R35, R42	00-026-330K
R19	00-024-100K
R20	00-022-100K

PARTS LIST FOR PCB ASSEMBLY CONTROL 20-163L (Continued)

REFERENCE DESIGNATION	PART NUMBER
R21, R124	00-024-1K
R22, R23	00-022-40.2K
R25	00-022-5.49K
R26	00-026-270K
R30	00-026-6.8K
R32	00-026-100K
R34, R38, R43, R46, R126	00-026-33K
R31	00-026-12K
R39, R47	00-026-180K
R51	00-026-20K
R53	00-023-500
R54	00-022-560
R55	00-022-1.62K
R101, R102, R108, R127, R134, R139, R147	00-026-4.7K
R103, R105, R107, R109, R111, R113, R115, R117, R119, R122, R128, R130, R132, R135, R137, R140, R145	00-026-220
R104, R106, R110, R114, R129, R133, R136, R144, R146	00-026-330
R112, R116, R131, R138, R141, R52	00-026-1.5K
R150, R151	00-026-2.2K
R125, R142	00-026-6.2K
U1, U4, U13	00-036
U2, U6, U14	00-037
U3, U5, U9, U12, U15, U17	00-012
U7, U11, U16	00-011
U8, U18	00-038
U10, U19	00-015
U20	00-017
U21	00-039
U22, U23, U24	00-018

PARTS LIST FOR PCB ASSEMBLY DATA A 20-355

REFERENCE DESIGNATION	PART NUMBER
C1, C4	00-140-.0047MF
C2, C8 - C10, C14 - C19, C32, C33	00-146-3.3MF
1C1 - 9C1	00-145-22MF
C5	00-140-.0022MF
C6	00-140-.033MF
C7	00-140-.022MF
C20 - C31, C34	00-147-6.8MF
1C2 - 9C2	00-136-68PF
1C3 - 9C3	00-140-.01MF
1C4 - 9C4	00-140-.0068MF
1C7 - 9C7	00-140-.001MF
CR1 - CR5, 1CR1 - 1CR11 thru 9CR1 - 9CR11	00-021
Q1, 1Q1 - 9Q1, 1Q2 - 9Q2	00-020
Q2, Q3, 1Q3 - 9Q3, 1Q4 - 9Q4	00-019
R1, R5, R16, 1R1 - 9R1, 1R5 - 9R5, 1R6 - 9R6	00-026-220
R2, R6, R11, R17, 1R2 - 9R2	00-026-330
R3, 1R3 - 9R3, 1R4 - 9R4	00-026-1.8K
R4, R21, R22, R26	00-026-3.3K
R7	00-026-390
R8	00-026-270
R9, R20, R24, R33, 1R19 - 9R19, 1R23 - 9R23, 1R29 - 9R29, 1R30 - 9R30	00-026-1K
R10	00-026-22
R12	00-026-470
R13	00-022-1K
R14	00-022-1.74K
R15	00-022-1.15K
R23	00-026-150
R25, R31, R32	00-026-2.2K
R27, R29	00-022-4.99K
R28	00-024-50K
R30	00-024-20K
1R7 - 9R7, 1R8 - 9R8	00-022-1.62K
1R9 - 9R9	00-026-27K
1R10 - 9R10	00-026-8.2K
1R11 - 9R11	00-022-178K
1R12 - 9R12	00-023-5K
1R13 - 9R13	00-022-34.8K
1R14 - 9R14, 1R15 - 9R15	00-022-10K

PARTS LIST FOR PCB ASSEMBLY DATA A 20-355 (Continued)

REFERENCE DESIGNATION	PART NUMBER
1R16 - 9R16, 1R22 - 9R22	00-026-4.7K
1R17 - 9R17	00-026-12K
1R18 - 9R18	00-026-3.9K
1R20 - 9R20, 1R24 - 9R24	00-026-100K
1R21 - 9R21	00-026-1MEG
U1, U5, U6	00-012
U2	00-017
U3	00-015
U4, U31	00-013
U12 - U16	00-181
U17 - U21	00-014
U22 - U30	00-018
U32, U33, U35, U37, U38	00-180
U34, U36	00-016

POWER FAIL RESTART OPTION
(WLI Part No. 20-309 and 20-344)
FOR
WILLARD LABORATORIES, INC. TAPE TRANSPORTS

THEORY OF OPERATION

The power fail restart option provides a safe means of restarting a WLI tape transport after power failure without the need of operator attendance.

Reference is made to the attached schematic (20-311). Figure 1 shows the block diagram of the circuit.

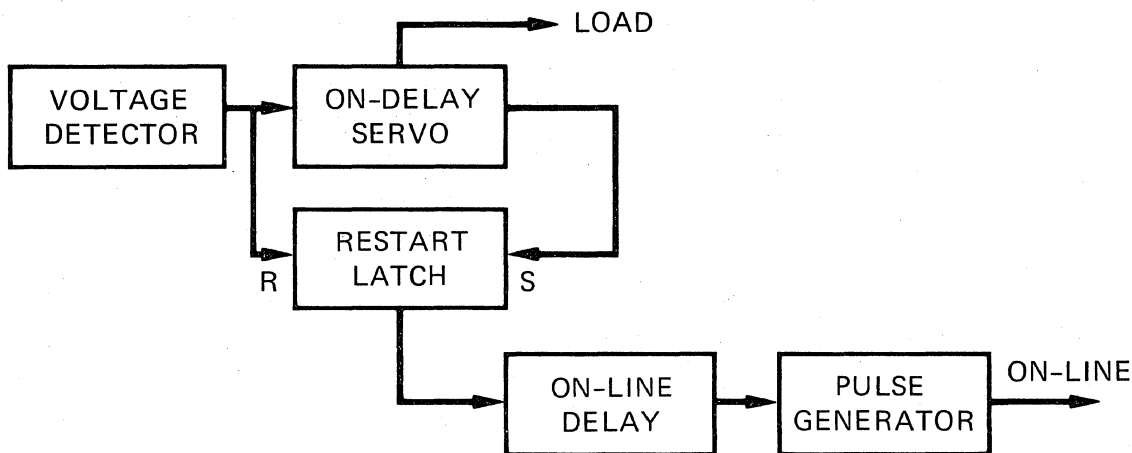

Figure 1

The voltage detector monitors the servo voltage (+14V - TPO4) and the relay and brake solenoid supply (-14VS - TB2-1). After the +14V supply reaches a level ensuring proper servo operation, the U1-A output goes to "0V" initiating a load operation (TP50).

CR5 and R7 provide compensation for the drop in servo voltage when the relay actuates the servo motors. After elapses of a time delay, generated by C2/R3, a latch (U1-B and U1-C) is set provided the relay (TP26) was actuated. This in turn causes the output of U1-A to go to +5V thereby terminating the load operation.

The latch will remain in the Set state until the servo supply voltage drops below a safe operation level causing the latch to be reset and thus permitting another load cycle. For a short power failure the latch will be reset by the -14VS which is sensed by V3-C and its input network. The -14VS supply is designed to decay very rapidly to zero to ensure, that the relay and brake solenoids are deactivated. U3-A and U3-B and R8 provide Hysterests. Turn-on of the unit occurs with a power input of 102VAC (typ.). If the input voltage drops below 95VAC (typ.), the unit will be turned on again if the voltage goes above 102VAC. The output of the latch triggers the on-line delay circuit (R4/C3). At the end of this delay a negative going pulse is generated, (C4/R5) which turns on the "On-Line" flip/flop.

In the case where tape tension can not be established (tape not threaded or no tape), the tape hubs will rotate approximately one revolution and then stop. A manual load operation may then follow. An optional switch (S1) may be provided to permit disabling the power fail restart circuitry.

Interconnections are made through the following connectors:

P104 (+14V)	to TP4 (yellow) on the Control PCBA
P126 (Relay)	to TP26 (blue) on the Control PCBA
P150 (Load)	to TP59 (green) on the Control PCBA
P105	to J05 (On-Line) on the Control PCBA
J105	to Control Panel On-Line Switch
P101, P102	to TB2-1 and solenoid L2-2 (black) on the power supply

The PCBA is mounted on the Power Supply cover and held in place by two screws.

PARTS LIST FOR PCB ASSEMBLY -
POWER FAIL RESTART 20-309B

REFERENCE DESIGNATION	PART NUMBER
C1	00-137-250MF
C2, C3	00-137-100MF
C4, C6, C7	00-140-0.047MF
C5, C8	00-147-6.8MF
CR1	00-173
CR2, CR3, CR4, CR5, CR6	00-021
CR7	00-048
U1	00-036
U2, U3	00-012
R1, R2, R7	00-026-620
R3, R4, R11	00-026-220
R5	00-026-4.7K
R6	00-026-1.2K
R8	00-026-2K
R9	00-022-2K
R10	00-022-750

REVISIONS				
REV	ENRCH	CHG BY	APPD BY	DATE
C	-	2-18-71		

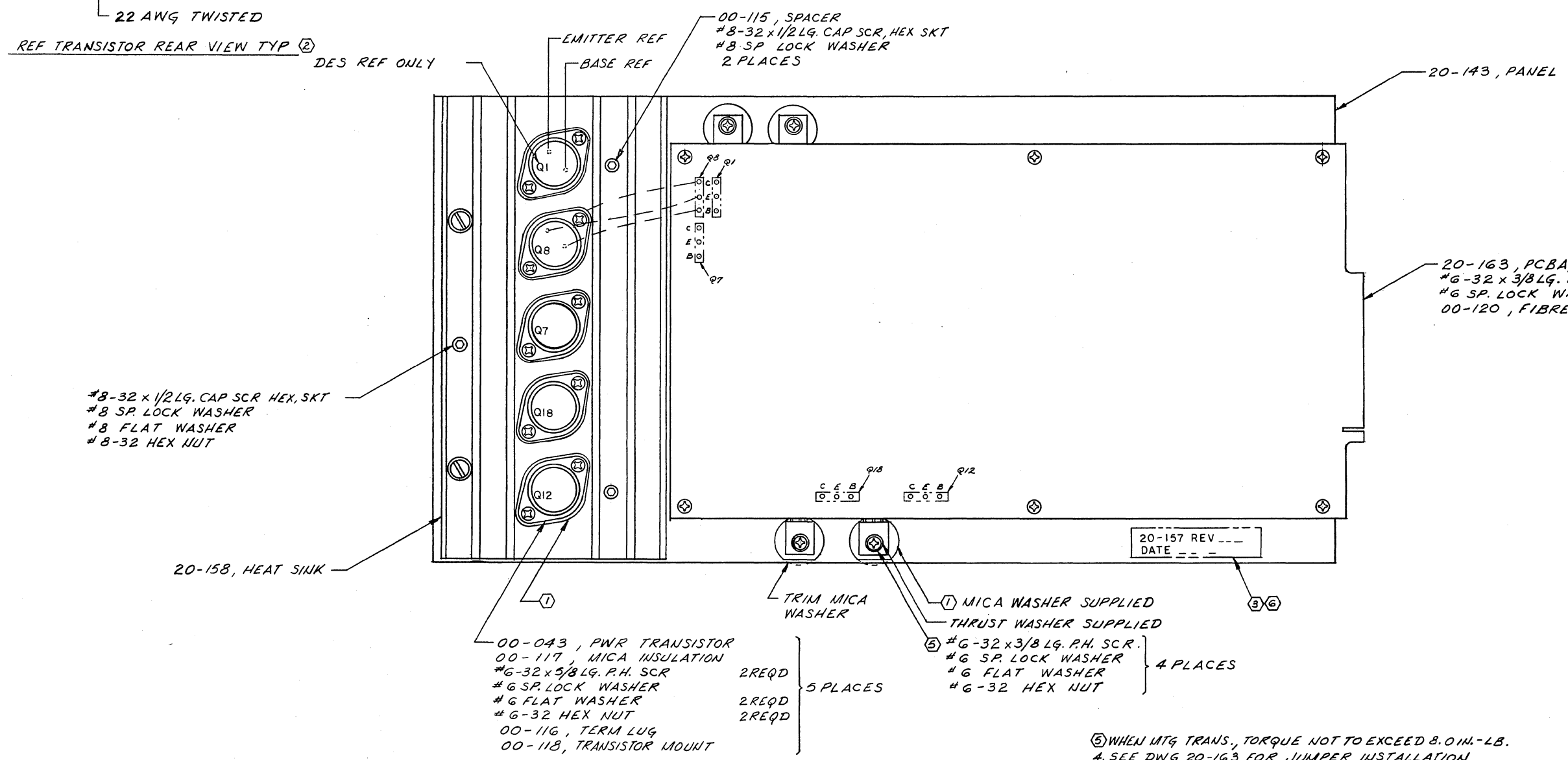
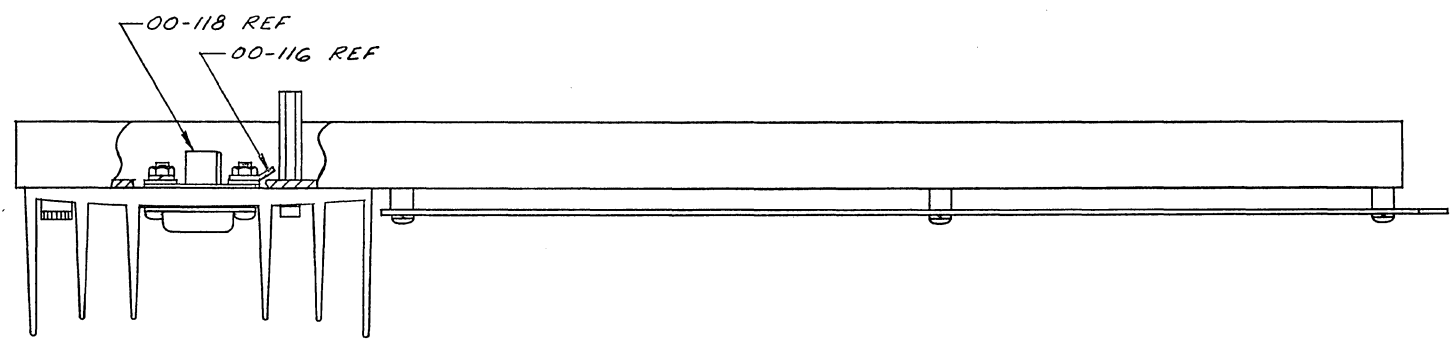
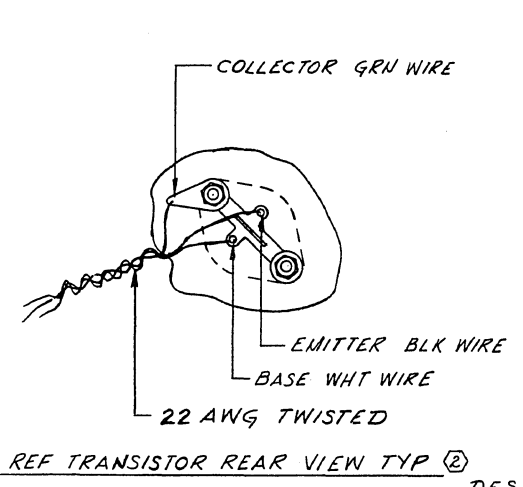

- 00-043, PWR TRANSISTOR
- 00-117, MICA INSULATION
- #6-32 x 3/8 LG. P.H. SCR 2REQD
- #6 SP. LOCK WASHER
- #6 FLAT WASHER 2REQD
- #6-32 HEX NUT 2REQD
- 00-116, TERM LUG
- 00-118, TRANSISTOR MOUNT

- MICA WASHER SUPPLIED
- THRUST WASHER SUPPLIED
- #6-32 x 3/8 LG. P.H. SCR.
- #6 SP. LOCK WASHER
- #6 FLAT WASHER
- #6-32 HEX NUT

7. REF ELECT. CONT. SCHEMATIC NO. 20-165.
8. FOR FINAL PART IDENTIFICATION REMOVE TAG AND RUBBER STAMP ASSY NO., REV. LETTER APPROX. WHERE SHOWN (REF DWG 20-248, 20-249)

5. WHEN MTG TRANS., TORQUE NOT TO EXCEED 8.0 IN.-LB.
4. SEE DWG 20-163 FOR JUMPER INSTALLATION
3. FOR PART IDENTIFICATION OF SUB-ASSY APPLY REMOVABLE TAG.
2. WIRE Q1, Q7, Q8, Q12, Q18 ON HEAT SINK TO MATCHING AREA ON PCBA.
1. APPLY THERMAL COMPOUND #58F470 ON BOTH SIDES OF MICA WASHER PRIOR TO INSTALLATION.
NOTES:

SEE B/M FOR PARTS

TOLERANCES UNLESS NOTED			
DECIMAL	ENR'D BY:	SCALE	DRAWN BY 2-2
FRACTIONAL	TITLE	DATE	APPROVED BY
ANGULAR	DATE	PROJECT: 007	20-157 C
		U/A: 20-248	

CODE IDENT NO
34358

00-033 PIN, FEMALE

RUBBER STAMP ASSY NO. WITH REV LTR
.12 HIGH

00-119 CAPTIVE SCR 2 REQD

PN20-357 ASSY 20-

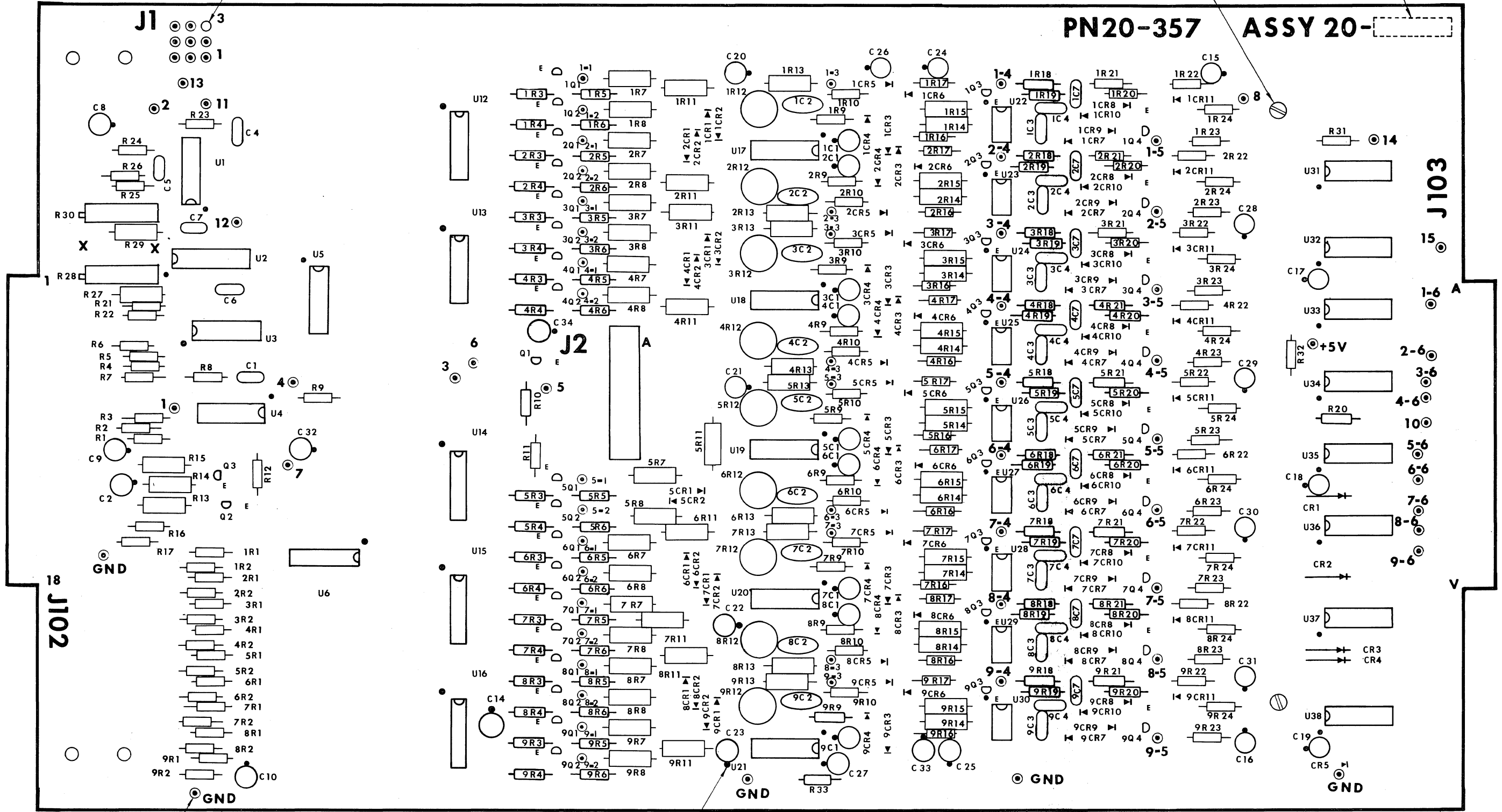

18
J102

J103

INDICATES PLUS (+) SIDE TYP.

00-032 PIN, MALE 82 REQD

1. SEE NEXT ASSY B/M FOR PARTS.
NOTES:

ITEM NUMBER	PART NUMBER	QTY.	NAME OR DESCRIPTION	MANUFACTURER OR MATERIAL	MFG. PART NO. OR MATERIAL SPEC.	NOTES
			UNLESS OTHERWISE SPECIFIED: 1. LINEAR DIMENSIONS IN INCHES 2. SHARP EDGES 300 MAX. 3. MACHINED SURFACE ROUGHNESS 63 MICRO-INCHES R.M.S. 4. DIMENSIONS APPLY BEFORE PLATING 5. MACHINED SURFACES SHALL BE A & B IN ALL PLANES .001 INCH DIAMETERS WITHIN .005 T.I.R. 6. ANGULAR TOLERANCES ± 0°-30° 7. LINEAR TOLERANCES: A ± .02; XXX ± .005; XXXX ± .0005			
20-356	REF					
20-355	REF					
NEXT ASSEMBLY			QTY. FOR NEXT ASSY.			
<p>THE TECHNICAL DATA AND THE DESIGN DISCLOSED HEREIN ARE THE EXCLUSIVE PROPERTY OF PRODUCERS SERVICE CORP. OR CERTAIN PROPRIETARY RIGHTS OF OTHERS AND ARE NOT TO BE REPRODUCED OR DISCLOSED TO OTHERS WITHOUT THE WRITTEN CONSENT OF PRODUCERS SERVICE CORPORATION.</p>						
				FINISH:		
				SCALE:	2/1	
				DATE:	7-5-72	
				DRAWN:	S. Kue	
				CHECKED:		
				ENGINEER:		
				PROJ. APPLV.:		
					<p>PRODUCERS SERVICE CORPORATION A SUBSIDIARY OF BOOTH COMPUTER CORP. GLENDALE, CALIFORNIA 91201</p>	
					PCB ASSY-DATA A	DWG. NO. 20-371
					DO NOT SCALE DRAWING	SHEET / OF /

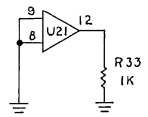
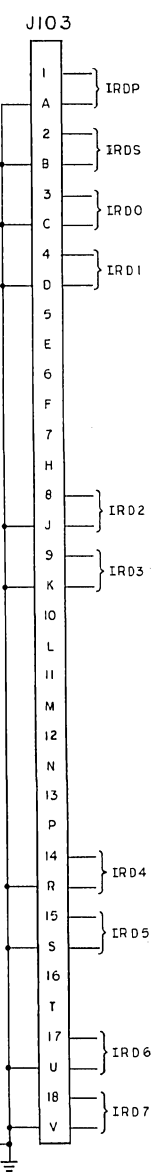
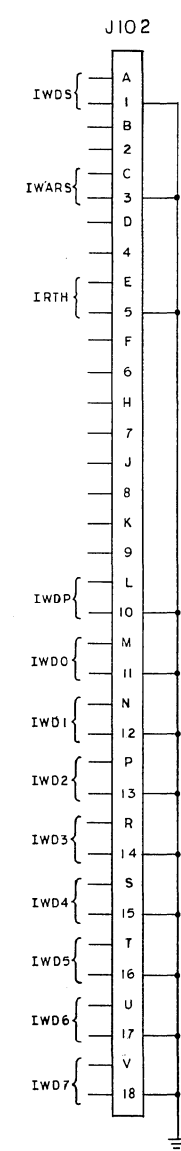
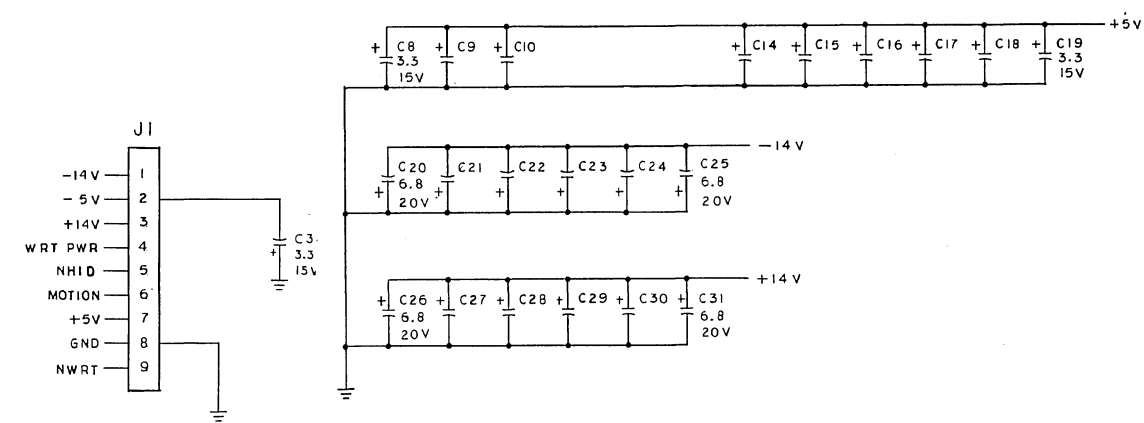

REF DESIGNATION		
LAST USED	NOT USED	
9C7	C34	C11-C13, IC6-9C6 C3, IC5-9C5
9CR11	CR5	
9Q4	Q3	
9R24	R33	R18,19
	U38	U7-U11
	J2	
9TP6	TP14	TP9

VERSION TABLE (6)		
REF. DES.	VALUES	
	20-355	20-356
C6	.033	.015
C7	.022	.01
IR11-9R11	178K	91K
IC1-9C1	22uF	10uF
IC4-9C4	.0068	.0033
IC3-9C3	.01	.005
IC7-9C7	.001	.0005

- (6) SEE VERSION TABLE FOR VALUES.
 5. FOR ASSY SEE DWG. 20-371
 4. U12 THRU U16 ARE 00-181, U32,33
 35,37,38 ARE 00-180, U1,5,6 ARE
 00-012, U4 & U31 ARE 00-013
 U17 THRU U21 ARE 00-014, U3 IS 00-015,
 U34 & U36 ARE 00-016, U2 IS 00-017,
 U22 THRU U30 ARE 00-018
 3. ALL CAPACITORS IN MICROFARADS
 2. ALL DIODES ARE 00-021
 1. ALL RESISTORS IN OHMS 1/4 W, 5%
 NOTES: UNLESS OTHERWISE SPECIFIED

WILLARD LABS, INC.

APPROVED	CHK'D BY: E.A.
BY:	2-16-71
SCHEMATIC	
DATA BOARD A	
PROJECT: 007	DWG NO. 20-358 A

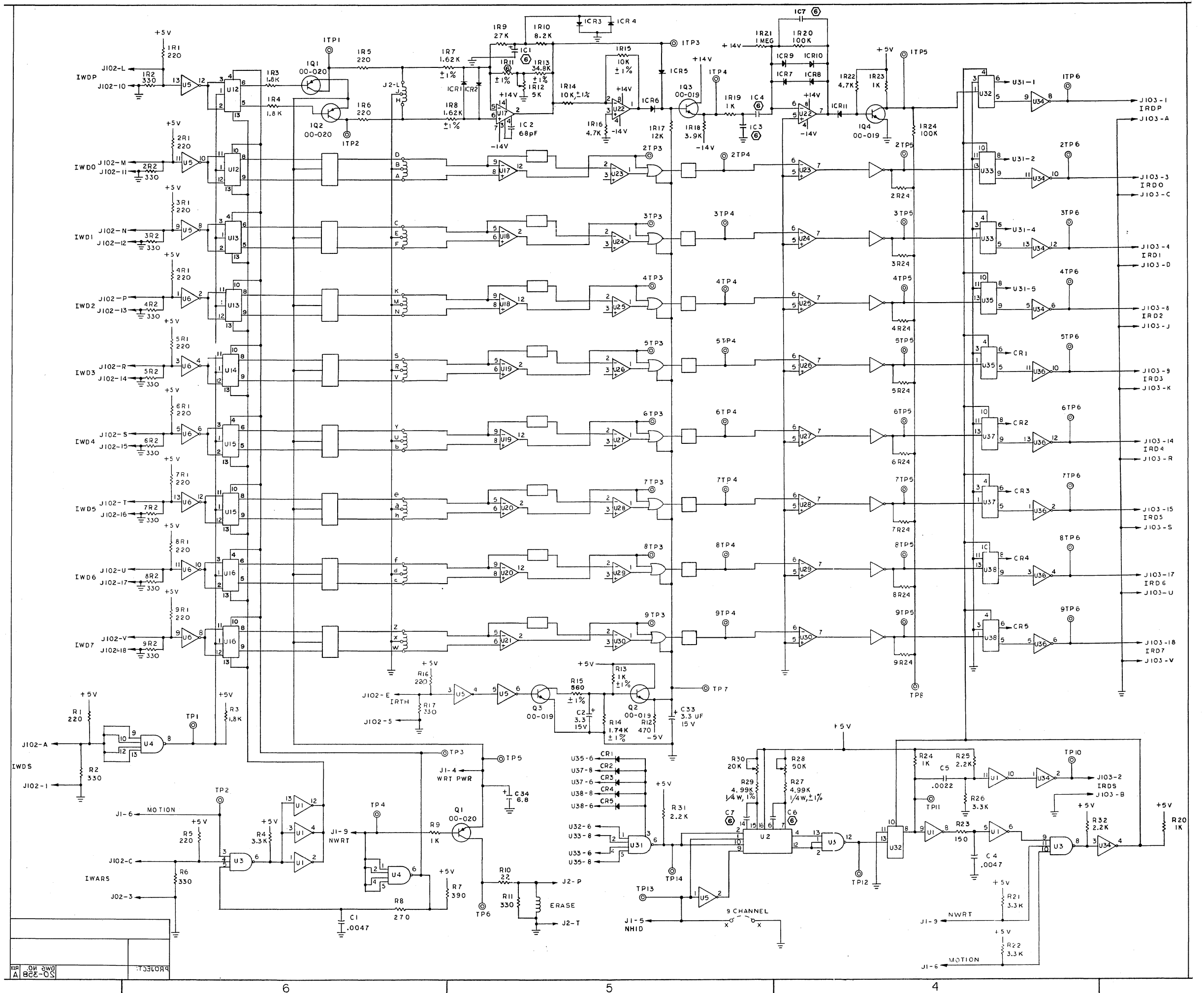

REV. 04 04/01
 A 802-05

REVISION			
REV	DATE	BY	APP'D
G	100043		
REDRAWN WITH CHANGES SILKSCREEN ADDED			
H	100109	S. Lee	12 71
J	100133	S. Lee	5 72
K	100134	S. Lee	5 72
L	100137	S. Lee	5 72

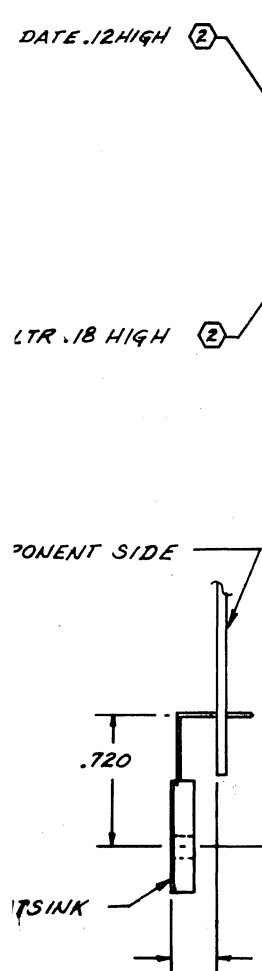
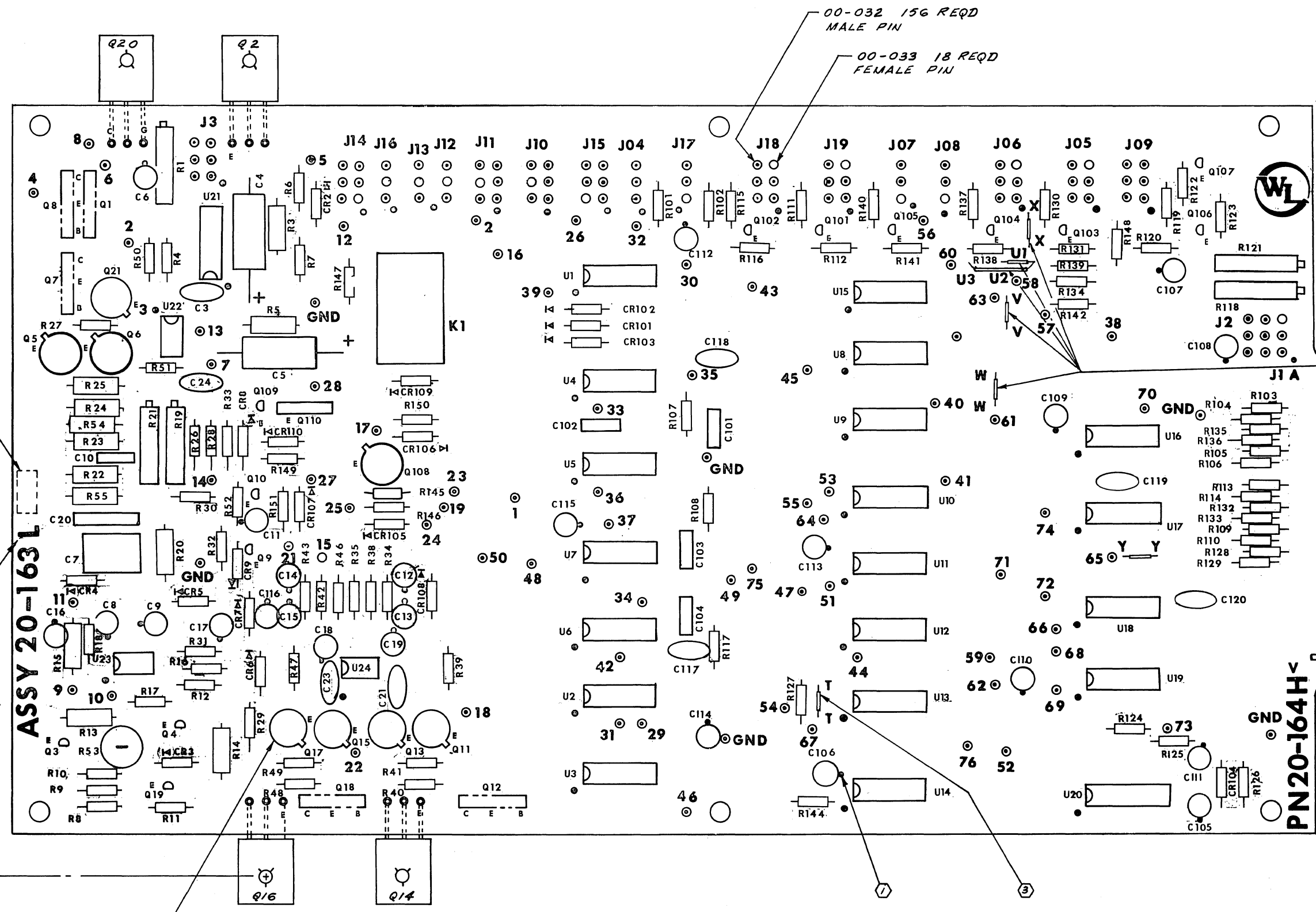

ASSY 20-163L

PN20-164H

ASSY NO.	JUMPER						
	T	V	W	X	Y	R	U1-U2/U1-U3
20-248 (DUAL DENS.)	X	X	X	X	X	X	
20-249 (9 TRACK)	X	X	X		X	X	X
20-346 (3 TRACK)		X	X		X	X	X

TYP INSTALLATION FOR Q2, Q14, Q16 & Q20

00-121, TRANSISTOR MFG. PAD 8 PLACES (Q5, Q6, Q11, Q13, Q15, Q17, Q21 & Q108)

4. REF SCHEMATIC NO. 20-165
 ③ SEE VERSION TABLE FOR INSTALLATION OF JUMPER "THRU" Y."
 ② RUBBER STAMP REVISION LETTER, ASSY DATE APPROX AS SHOWN.
 ① DOT ON CAPACITOR INDICATES PLUS (+) SIDE.
- NOTES:

SEE B/M FOR PARTS

<p>WILLARD LABORATORIES, Inc. 15 REDWOOD AVENUE SAN ANTONIO, TEXAS 78206</p>	<p>WILLARD LABORATORIES, Inc. 15 REDWOOD AVENUE SAN ANTONIO, TEXAS 78206</p>	<p>PCB ASSY - CONTROL</p>
<p>SIZE: D CODE IDENT NO: 34358 DRAWING NO: 20-163</p>	<p>REV: 1</p>	<p>SCALE: 2:1 SHEET: 1 OF 1</p>

REVISIONS			
REV	DATE	BY	REASON
A			
B			
C			
D			
E			
F			
G			

SH 1 ADDED C24, TP2, AND GND TO JIG-3.
 SH 2 REMOVED U10, JUMPER E, TP17 AND WRT FROM J1-5.
 SH 3 ADDED TO J10 10V.
 SH 4 ADDED C17/C18.
 SH 5 JUMPER K1-B HAS R14,8 ABOVE CHANGES PER ECO100097

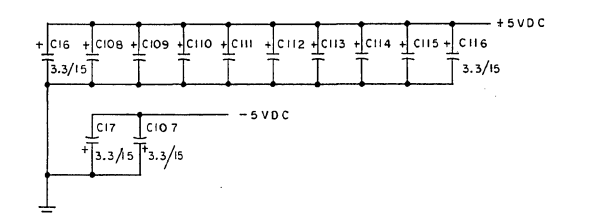
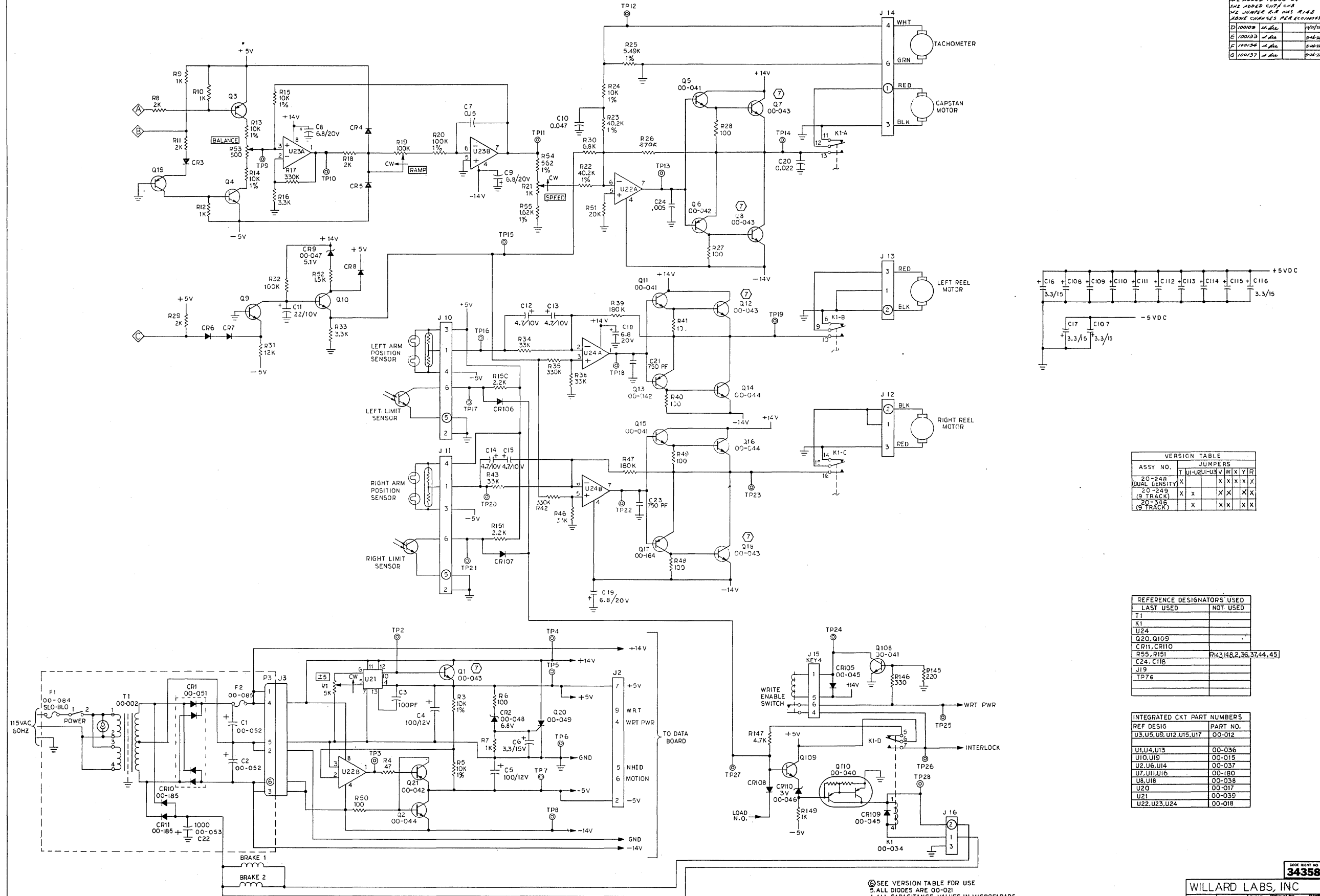

ASSY NO.	JUMPERS									
	T	U	U2	U3	U3	W	X	Y	Z	R
20-248	X					X	X	X	X	X
20-249	X	X				X	X	X	X	X
20-249 (9 TRACK)	X	X				X	X	X	X	X
20-246 (9 TRACK)	X					X	X	X	X	X

REFERENCE DESIGNATORS USED	
LAST USED	NOT USED
T1	
K1	
U24	
Q20, Q109	
CR11, CR110	
R55, R151	R143, 148, 2, 36, 37, 44, 45
C24, C118	
J19	
TP76	

INTEGRATED CKT PART NUMBERS	
REF DESIG	PART NO.
U3, U5, U9, U12, U15, U17	00-012
U1, U4, U13	00-036
U10, U19	00-015
U2, U6, U14	00-037
U7, U11, U16	00-180
U8, U18	00-038
U20	00-017
U21	00-039
U22, U23, U24	00-018

SEE VERSION TABLE FOR USE
 5. ALL DIODES ARE 00-021
 4. ALL CAPACITANCE VALUES IN MICROFARADS
 3. ALL RESISTORS ARE 1/4 WATT, ±5% VALUES IN OHMS
 2. ALL PNP TRANSISTORS ARE 00-020
 1. ALL NPN TRANSISTORS ARE 00-019
 NOTE: UNLESS OTHERWISE SPECIFIED

FOR ASSEMBLY DRAWINGS SEE 20-157 & 20-118
 TRANSISTOR MOUNTED ON HEAT SINK

WILLARD LABS, INC
 34358
 PROJ 007 JEF JEF 2/23/71
 TITLE SCHEMATIC CONTROL ELECTRONICS
 DRAWING NO. 20-16.5
 SHEET 1 OF 2

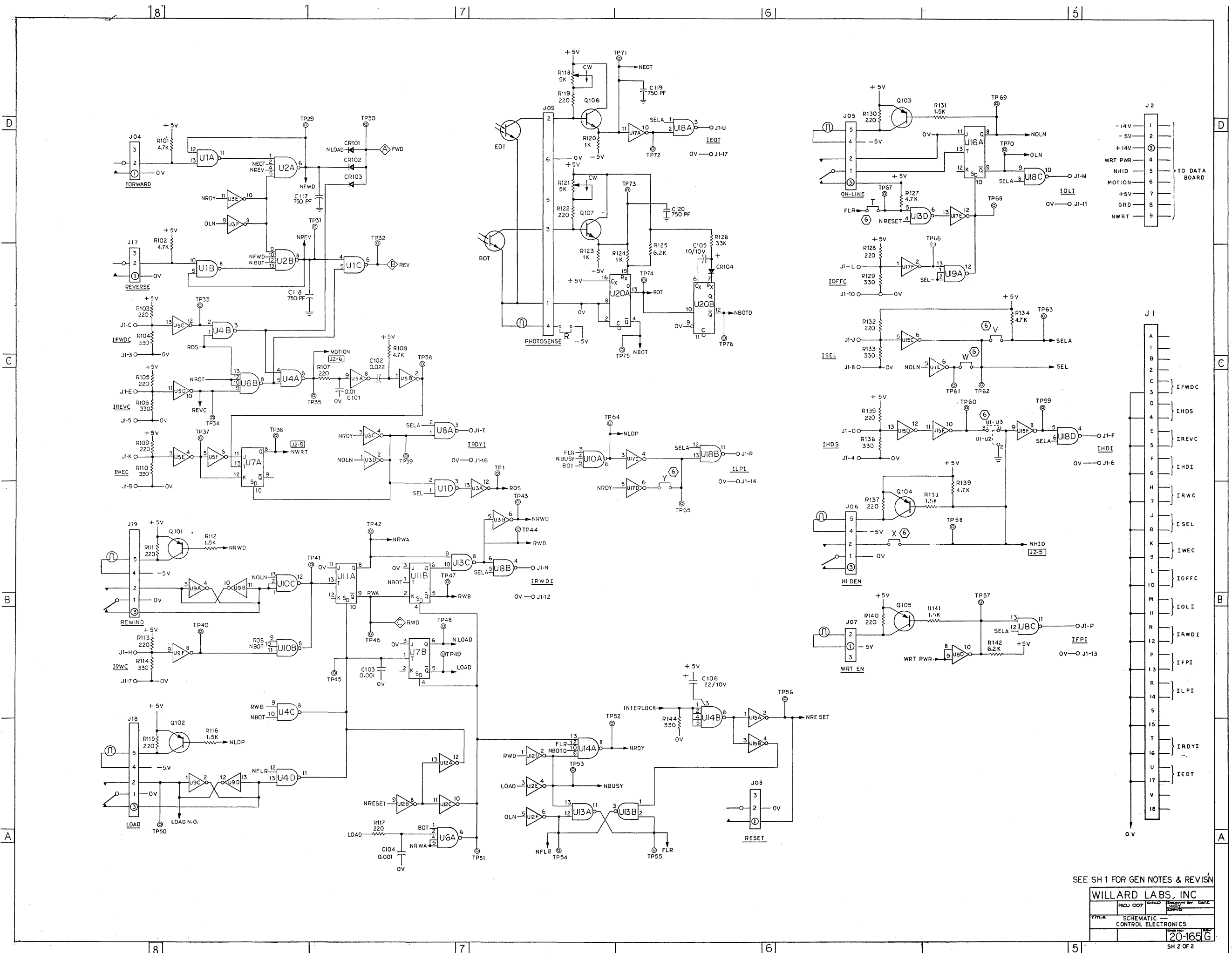

SEE SH 1 FOR GEN NOTES & REVISION

WILLARD LABS. INC	
PROJ. COO	DESIGNED BY DATE
FILE	SCHEMATIC
CONTROL ELECTRONICS	
20-1656	