

TEXAS INSTRUMENTS

Improving Man's Effectiveness Through Electronics

Model 960B/980B Computer Maintenance Manual Power Supply

MANUAL NO. 942773-9703
ORIGINAL ISSUE 1 SEPTEMBER 1974
REVISED AND REISSUED 1 FEBRUARY 1977
INCLUDES
CHANGE 1 1 MAY 1978

Digital Systems Division



The information and/or drawings set forth in this document and all rights in and to inventions disclosed herein and patents which might be granted thereon disclosing or employing the materials, methods, techniques or apparatus described herein, are the exclusive property of Texas Instruments Incorporated.

LIST OF EFFECTIVE PAGES

INSERT LATEST CHANGED PAGES DESTROY SUPERSEDED PAGES

Note: The portion of the text affected by the changes is indicated by a vertical bar in the outer margins of the page.

Model 960B/980B Computer Maintenance Manual: Power Supply (942773-9703)

Original Issue	1	September 1974
Change 1	1	September 1975 (ECN 393167)
Change 2	1	February 1976 (ECN 409318)
Revised and Reissued	1	February 1977 (ECN 419666)
Change 1	1	May 1978 (ECN 419829)

Total number of pages in this publication is 144 consisting of the following:

PAGE NO.	CHANGE NO.	PAGE NO.	CHANGE NO.	PAGE NO.	CHANGE NO.
Cover	1	4-12 - 4-18	1	6-1 - 6-70	1
Effective Pages	1	4-19 - 4-21	0	Alphabetical Index Div.	0
iii - v	0	4-22 - 4-26	1	Index-1 - Index-4	0
1-0 - 1-4	0	5-1 - 5-5	0	User's Response	1
2-1	1	5-6 - 5-7	1	Business Reply	1
2-2 - 2-4	0	5-8	0	Cover Blank	0
3-1 - 3-2	0	5-9 - 5-10	1	Cover	0
4-1 - 4-9	0	5-11	0		
4-10	1	5-12	1		
4-11	0	5-13 - 5-26	0		



TABLE OF CONTENTS

Paragraph	Title	Page
SECTION I. INTRODUCTION		
1.1	Scope of Manual	1-1
1.2	Description of Power Supply	1-1
1.3	Power Supply Specifications	1-1
1.4	Battery	1-1
SECTION II. INSTALLATION		
2.1	Power Supply Installation	2-1
2.2	Power Supply Removal	2-2
SECTION III. OPERATION		
3.1	General	3-1
3.2	Power Supply Controls	3-1
SECTION IV. THEORY OF OPERATION		
4.1	General Theory	4-1
4.1.1	Regulation	4-1
4.1.2	Sequencing and Control	4-4
4.1.3	Overvoltage Protection	4-5
4.1.4	Overcurrent Protection	4-6
4.1.5	Battery Charging	4-7
4.2	Detailed Theory	4-8
4.2.1	+5V MAIN Regulator and Control	4-8
4.2.2	Memory, Auxiliary, and Reference Regulator	4-18
4.2.3	± 15 Volt Regulator	4-23
4.2.4	Rectifier, Filter, and Output	4-23
4.3	Logic Control Signals	4-24
SECTION V. MAINTENANCE		
5.1	Introduction	5-1
5.2	Preventive Maintenance	5-1
5.2.1	Clean Air Filter	5-1
5.2.2	Battery Check	5-2
5.3	Test Equipment	5-5
5.4	Trouble Analysis	5-5
5.5	Signal Waveforms	5-16



TABLE OF CONTENTS (Continued)

Paragraph	Title	Page
-----------	-------	------

SECTION VI. DRAWINGS

LIST OF ILLUSTRATIONS

Figure	Title	Page
1-1	Model 960B and 980B Computer Power Supply	1-0
2-1	Power Supply Position Within Chassis	2-3
3-1	Power Supply Rear Panel Controls	3-1
4-1	Series Regulator Circuit Diagram	4-1
4-2	Switching Regulator Circuit Diagram	4-2
4-3	Switching Regulator Waveforms	4-3
4-4	Overvoltage Protection and Power Distribution Functional Diagram	4-5
4-5	Current Limiting Circuitry for Series Regulators . . .	4-6
4-6	Current Limiting Circuit for Switching Regulator . . .	4-7
4-7	Battery Charging System	4-8
4-8	Power Supply Block Diagram	4-9
4-9	Switching Regulator Waveforms	4-11
4-10	Commutating Diode Waveform - No Load	4-12
4-11	Turn-On Sequence Timing	4-15
4-12	Turn-Off Sequence Timing	4-15
5-1	Battery Test Chart	5-4
5-2	Waveform 1	5-17
5-3	Waveform 2	5-18
5-4	Waveform 3	5-19
5-5	Waveform 4	5-20
5-6	Waveform 5	5-21
5-7	Waveform 6	5-22
5-8	Waveform 7	5-23
5-9	Waveform 8	5-24
5-10	Waveform 9	5-25
5-11	Waveform 10	5-26



LIST OF TABLES

Table	Title	Page
1-1	Physical and Environmental Characteristics	1-2
1-2	Input Power Characteristics	1-2
1-3	Output Power Characteristics	1-3
1-4	Overvoltage Protection Tolerances	1-3
3-1	Power Supply Controls	3-1
4-1	Overvoltage Sensor Trigger Levels	4-5
4-2	All Regulator Up Sensor Levels	4-16
5-1	Test Equipment for Power Supply Maintenance	5-5
5-2	Failure Types	5-7
5-3	Failure Location	5-9

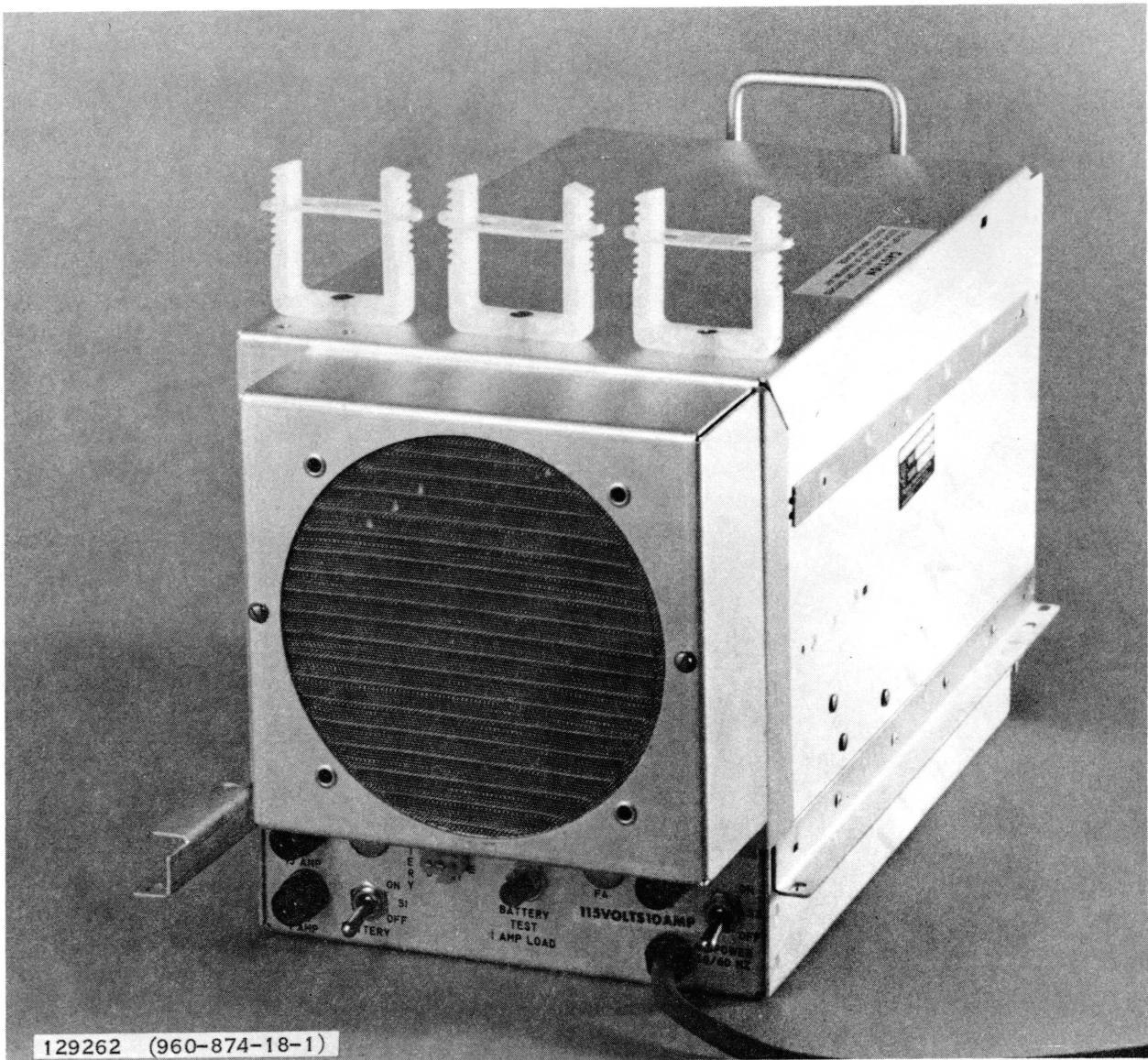

Figure 1-1. Model 960B and 980B Computer Power Supply



SECTION I

INTRODUCTION

1.1 SCOPE OF MANUAL

This manual contains the information needed to install, operate and maintain the power supply (figure 1-1) for the Texas Instruments Model 960B and 980B Computers. It includes a description of the power supply, its operating characteristics, installation and removal instructions, and operating instructions for the power supply controls. Also included are the principles of the power supply's operation, procedures for preventive maintenance and trouble analysis, assembly and electrical drawings, and parts lists.

1.2 DESCRIPTION OF POWER SUPPLY

The power supply provides electrical power to the computer system. It also contains the system cooling fan. The power supply chassis acts as an air plenum and provides air metering to printed circuit cards in the system.

The power supply provides six regulated outputs and one unregulated output. Regulated dc outputs from the power supply are +5V, -5V, +5V standby (STBY), 12V, +15V and -15V. The unregulated output from the power supply is ± 35 V ac. The ± 35 V ac is used for external rectification, filtering, and regulation. The rectified, filtered, and regulated outputs are the dc voltage levels required for computer operation.

1.3 POWER SUPPLY SPECIFICATIONS

The power supply is a self-contained unit which connects to the computer backplane. Physical and environmental characteristics of the power supply are listed in table 1-1. The power supply requires a 3-wire ac input power source with a frequency tolerance of 47 to 63 Hz. The voltage alternatives are 100 V +15%, -10%, one-phase; 115 V $\pm 10\%$, one-phase; 200 V +15%, -10%, two-phase; and 230 V $\pm 10\%$, two-phase. The maximum required input current is 6 amperes for a fully equipped computer operating on 100 V ac input power. The power supply input power requirements are listed in table 1-2, and output power characteristics are listed in table 1-3.

In addition to providing power to the computer, the power supply moves cooling air through the system. The power supply is thermally protected and all regulators except the ± 15 V regulator are short-circuit protected. Overvoltage protection tolerances are listed in table 1-4.

1.4 BATTERY

An optional, externally mounted battery is connected to the power supply through a connector on the rear of the power supply. This battery maintains the -5V, the +5V STBY and +12V outputs in the event of a primary power failure.



Table 1-1. Physical and Environmental Characteristics

Characteristic	Specification
Height	9.2 inches
Depth	18.0 inches
Width	8.2 inches
Weight	36.5 pounds
Operating temperature (air entering unit)	0°C to 50°C at sea level and 60 Hz* 0°C to 45°C at sea level and 50 Hz*
Storage temperature	-55°C to 70°C
Humidity:	
Storage	0% to 95% relative humidity
Operating	0% to 95% relative humidity, noncondensing
Altitude	0 to 10,000 feet
Shock:	
Operating	1 G
Shipping	30 G to shipping carton

*Upper operating temperature. Derate by 2°C for each 2500 feet of altitude. Derate 5°C for 50 Hz operation.

Table 1-2. Input Power Characteristics

Characteristic	Specification
Voltage	100 V +15%, -10% 115 V ±10% 200 V +15%, -10% 230 V ±10%
Frequency	47 to 63 Hz
Current	6 amp maximum at 100 V



Table 1-3. Output Power Characteristics

Nominal Voltage (volts)	Voltage Tolerance (percent)	AC Operation Full Load Current (amperes)	Battery Operating Current (32K Memory Protect) (milliamperes)
-5	±5	0.05	17
+5 MAIN	±2	30.0	Off
+5 STBY	±3	3.0	30
+12 MEM	±3	2.0	250
±15	±5	0.35	Off

Table 1-4. Overvoltage Protection Tolerances

Nominal Voltage (volts)	Lower Trip Limit (volts)	Upper Trip Limit (volts)
-5	-5.6	-7.0
+5 MAIN	+5.4	+6.3
+5 STBY	+5.6	+6.5
+12 MEM	+12.6	+13.5
±15	None	None

Standby power is much lower than normal operating power and only refreshes computer memory. Two 4.5 ampere-hour, 12-volt, spill-proof, lead-acid or jelled electrolyte batteries supply standby power. A battery charger within the power supply can charge a discharged battery to 80 percent of capacity in 20 hours and to 100 percent of capacity in 48 hours. Standby power duration depends on battery age, ambient temperature, and quantity of memory. A voltage-controlled latch lights the POWER LOSS indicator on the computer control console if the battery is low enough to cause possible loss of memory in standby operation. A weak battery can be detected in the normal mode by pushing the BATTERY TEST switch.



SECTION II INSTALLATION

2.1 POWER SUPPLY INSTALLATION

Perform the following steps to install the power supply in the computer chassis.

WARNING

Failure to observe the following three steps before installing power supply may result in personal injury and/or damage to the equipment.

1. Ensure that the power cord is not connected to an ac power source.
2. Set Power switch and BATTERY switch on the rear of the power supply to the OFF position.
3. Ensure that no foreign objects are in the power supply connector on the computer backplane.
4. Place the power supply into the computer chassis in the area indicated in figure 2-1, and ensure that the printed circuit card at the front of the power supply mates with the backplane connector.

CAUTION

Failure to properly secure the power supply in the computer chassis will cause damage to the backplane connector when the computer is moved.

5. Secure the power supply to the computer chassis using five 10 - 32 x 3/8 mounting screws.
6. If the battery option is included in the computer, connect the battery cable to the BATTERY connector on the rear of the power supply.
7. Remove all circuit boards from the computer chassis.
8. Connect the power cord of the power supply to an ac power source that matches the input requirements of the power supply as indicated in Section I of this manual.
9. Set Power switch to ON; set BATTERY switch to ON.
10. Use a voltmeter to check the output voltages on the computer backplane. Voltages must be within tolerances specified in Section I of this manual.



11. If voltages are within tolerance, set Power and BATTERY switches to OFF, reinstall circuit boards in computer chassis, and return switches to ON. If voltages are not within tolerance, correct problem before operating computer.
12. If POWER LOSS indicator lights after power-up, actuate the RESET switch on the control console to extinguish it.
13. Press the BATTERY TEST switch on the rear of the power supply. POWER LOSS indicator should not light. If POWER LOSS indicator lights, confirm that the battery cable is properly connected to the power supply, actuate RESET on the control console and press BATTERY TEST again. If POWER LOSS indicator still lights, recharge or replace battery pack.

2.2 POWER SUPPLY REMOVAL

Perform the following procedure to remove the power supply from the computer chassis.

1. Set the power switch to OFF.
2. Set the BATTERY switch to OFF.
3. Disconnect the battery pack cable from rear of power supply (if battery option installed).
4. Unplug the power cord from the power receptacle.
5. Remove five screws that fasten the power supply to the chassis.
6. Carefully lift the power supply up and out of the chassis.

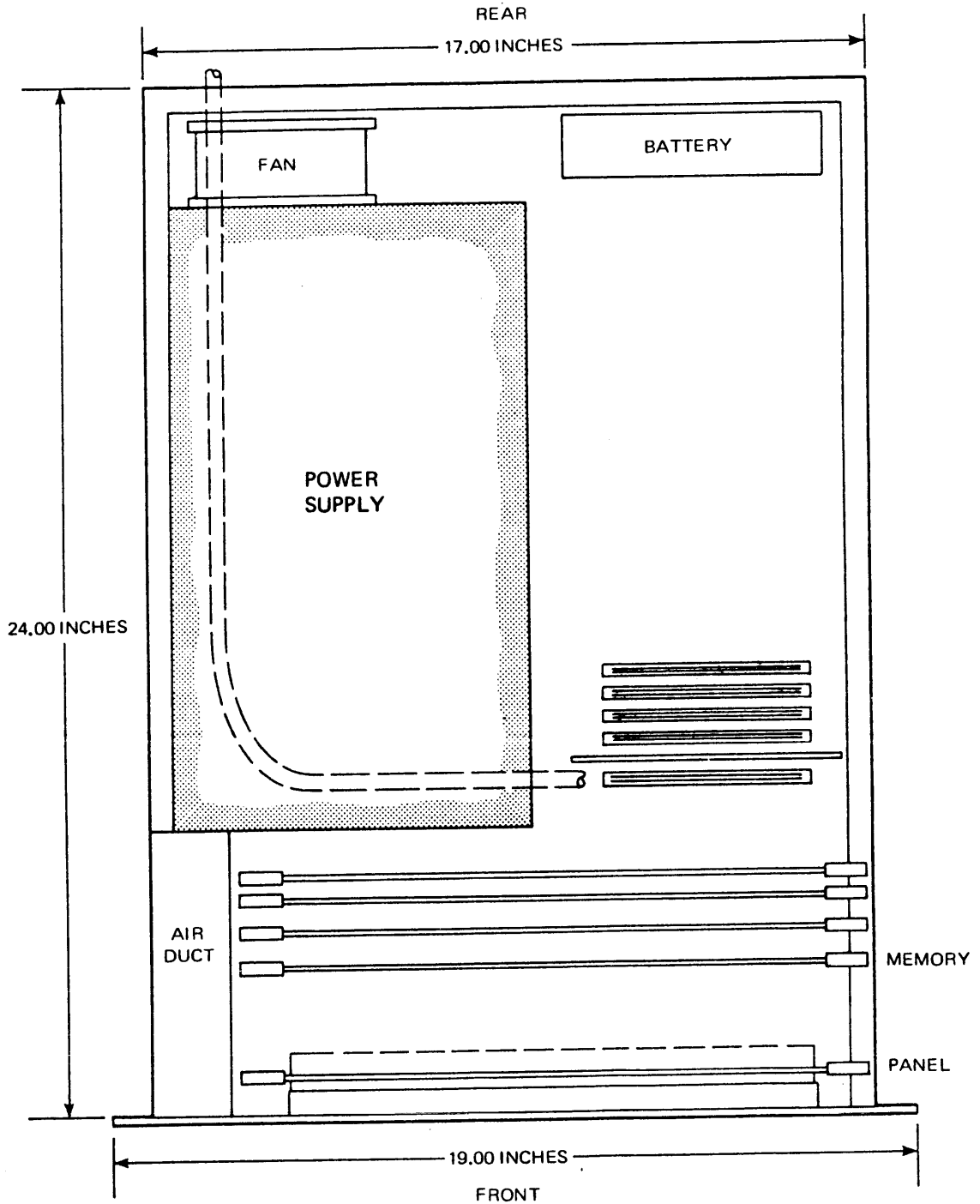

(A) 129263

Figure 2-1. Power Supply Position Within Chassis



SECTION III OPERATION

3.1 GENERAL

This section describes the function of the controls and indicators for the computer power supply. Instructions for initial power-up of a new power supply are found in Section II of this manual. Section V of this manual contains operator preventive maintenance procedures, as well as repair and fault isolation instructions.

3.2 POWER SUPPLY CONTROLS

Figure 3-1 illustrates the controls on the rear panel of the computer power supply. Table 3-1 defines the function of each of the controls.

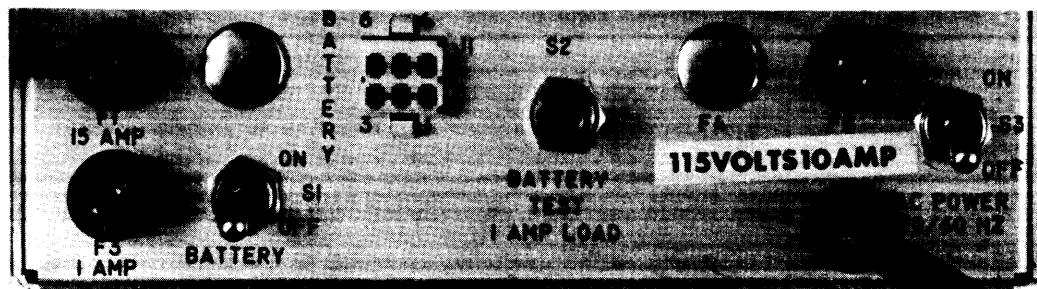

129264 (960-874-18-2)

Figure 3-1. Power Supply Rear Panel Controls

Table 3-1. Power Supply Controls

Nomenclature	Device	Function
F1	Fuse, 15 amp	Protects high voltage secondary windings of the transformer from overload.
F3	Fuse, 1 amp	Protects battery from an excessive charging or discharging current.
F5	Fuse, 10 amp @ 100 or 115 Vac 5 amp @ 200 or 230 Vac	Protects the primary ac power circuit.



Table 3-1. Power Supply Controls (Continued)

Nomenclature	Device	Function
F4	Fuse, 5 amp	Protects primary ac power circuit. This fuse is included in 200 and 230 Vac units only.
J1	Connector, male	Electrical connection between power supply and battery.
BATTERY (S1)	Toggle switch	When set to ON, enables the optional battery to supply power to memory in the event of a primary power failure, and to receive a charge from the power supply when primary power is on. When set to OFF, this switch disables battery operation and charging.
BATTERY TEST (S2)	Pushbutton	When pressed, this pushbutton applies a 1 amp load to the battery to test its operation. If the battery fails the test (when Power switch is set to ON), the POWER LOSS indicator on the computer control console will light.
Power (S3)	Toggle switch	When set to ON, this switch applies ac electrical power to the power supply. When set to OFF, this switch disables power supply operation by removing primary ac power.



SECTION IV THEORY OF OPERATION

4.1 GENERAL THEORY

Major functions of the power supply circuits include: regulation, sequencing and control, overvoltage protection, overcurrent protection, and battery charging. Each of these functions is described in separate paragraphs which follow.

4.1.1 REGULATION

Two basic types of regulators are used to generate voltages in the power supply. The two types of regulators are series and switching regulators. All voltages except the +5V MAIN are generated by series type regulators. For efficiency, a switching regulator is used for the +5V MAIN 30-ampere regulator.

A basic series regulator circuit diagram is illustrated in figure 4-1. Pass transistor Q1 is connected in series with the load. Conduction of the pass transistor is controlled by an amplifier with an output that is derived by nulling feedback voltage V_F with reference voltage V_R . Since the amplifier input impedance is high, R_1 and R_2 form a voltage divider across output voltage V_0 . Feedback voltage V_F is then the product of V_0 and the ratio of R_2 to the sum of R_1 and R_2 . Since V_F is nulled against V_R , V_0 is the function of V_R as follows:

$$V_0 = \frac{R_1 + R_2}{R_2} V_R = \left(1 + \frac{R_1}{R_2}\right) V_R$$

For the case where R_2 is eliminated (i. e., $R_2 = \infty$) $V_0 = V_R$.

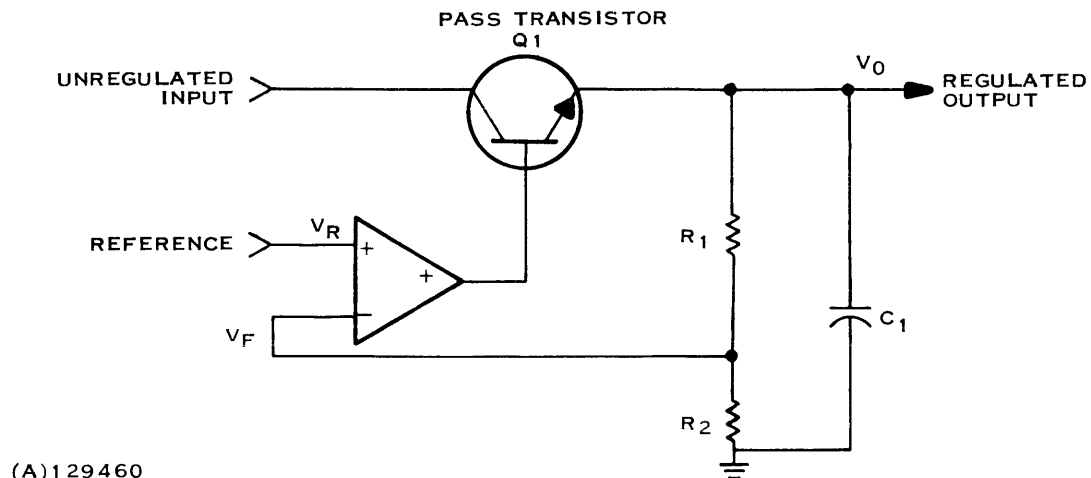

Figure 4-1. Series Regulator Circuit Diagram



As the load changes, the amplifier increases or decreases the drive (base current) to the pass transistor to maintain the required output voltage.

A basic switching regulator circuit diagram is illustrated in figure 4-2. In this circuit, the pass transistor is also connected in series with the load. Regulation of the output voltage is accomplished by switching the transistor on and off. The on-off duty cycle of the pass transistor is controlled by the difference (error signal) between the inverting and non-inverting inputs of the voltage comparator. A triangular synchronizing signal is superimposed on the reference voltage at the non-inverting input. This synchronizing signal establishes the switching frequency consistent within the constraints of the switching losses. The output voltage is applied to the inverting input of the comparator. When the output voltage is less than the voltage at the non-inverting input of the comparator, the duration of the on-time pulse increases. The pass transistor then conducts for a longer period of time; therefore, the output voltage rises. As the output rises, the error signal becomes smaller and the duration of the on-time pulse decreases. The pass transistor then conducts for a shorter period of time resulting in an output voltage decrease. A filter consisting of an inductor-capacitor (L1 and C1) network and a commutating diode (CR1) is connected between the pass transistor and the load to obtain a smooth direct current output.

Typical switching regulator waveforms are illustrated in figure 4-3. The triangular synchronizing signal is shown combined with the reference signal

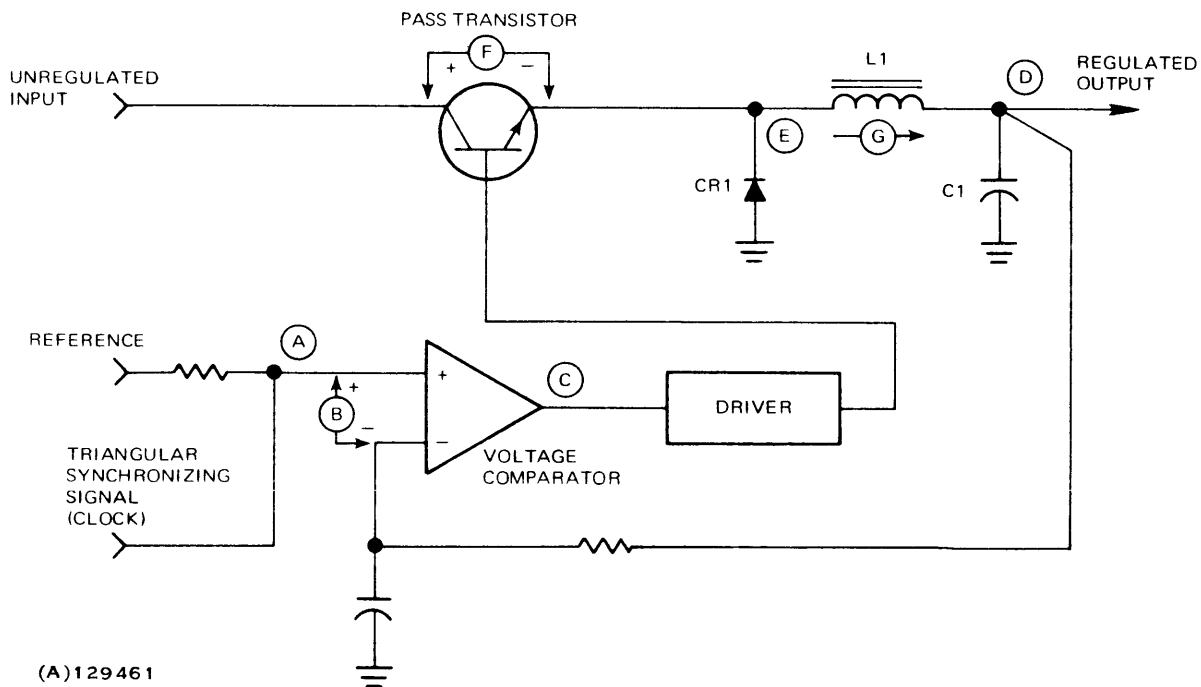

(A)129461

Figure 4-2. Switching Regulator Circuit Diagram

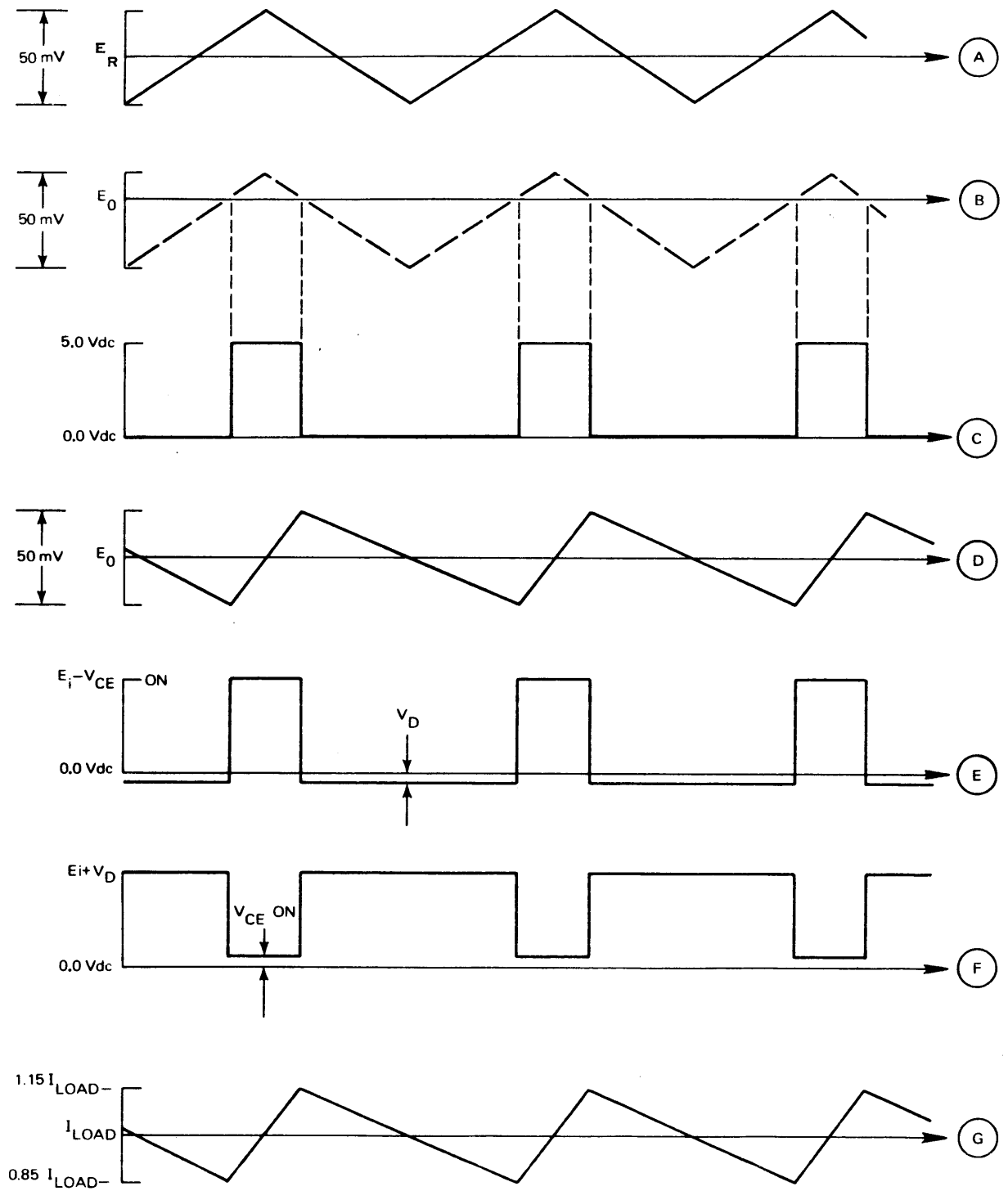

(A)129462

Figure 4-3. Switching Regulator Waveforms



E_R (figure 4-3, reference A). The dc output, E_0 that appears at the inverting input is shown (figure 4-3, reference B) with respect to the signal at the non-inverting input of the comparator. When the inverting input decreases below the non-inverting input, the output of the comparator goes high (figure 4-3, reference C) and causes the driver to turn on the pass transistor. During this part of the cycle, CR1 is back-biased by the input voltage minus the on-voltage of the transistor (figure 4-3, reference E). The voltage across choke L1 is the difference between the output voltage and the input voltage minus the transistor on-voltage. This causes the current through the choke to increase linearly with time (figure 4-3, reference G). When the output voltage is more positive than the signal at the non-inverting input, the comparator output goes low. The pass transistor is thereby turned off and stops conducting. Since the current through an inductor cannot change instantaneously, current is supplied through diode CR1. The output side of the inductor is held at the output voltage. The other side of the inductor tries to swing negative but is clamped to a diode drop below ground. This voltage polarity change, across the inductor, causes current through the inductor to decrease linearly. The current continues to decrease until the comparator senses the output voltage is too low and turns on the pass transistor. The output ripple is shown with respect to E_0 in figure 4-3, reference D.

4.1.2 SEQUENCING AND CONTROL

The power supply has a complex sequencing and control system. Two sequenced signals are control signals for the computer. These signals are MRESET- and POFF. The MASTER RESET (MRESET-) signal stays a logic zero until all voltages stabilize. When stabilization is achieved, this signal becomes a logic one. The POFF pulse is generated when loss of ac power occurs. Typically, the POFF pulse occurs 16 to 18 milliseconds after ac power is lost. The pulse can be generated between 6.0 milliseconds and 30 milliseconds after ac power is lost. The length of time is determined by the line voltage and load currents.

During the turn-on sequence, all voltages except +5V MAIN come up as soon as ac power is up. An ON-DELAY signal prevents +5V MAIN from coming up. When the ON DELAY- signal goes high, the 60 kHz clock is present, and MRESET- is low, the +5V REF is enabled and starts to ramp up. The +5V REF continues to ramp up to +5V unless an overload occurs. If there is an overload, +5V REF is disabled, and the overload latch is enabled. The ac power must be turned off and then on to enable the +5V REF again.

If an overload condition does not exist, all regulators come up and MRESET- goes high. The +5V MAIN is maintained if the ac power remains on, the 60 kHz clock is present, and all regulator voltages are up.

The Memory Power Loss is a control signal (MPLOSS-). This control signal line is pulled to ground when the battery voltage falls below the value necessary to guarantee maintenance of standby power. The circuit that controls



this function is a latch that must be reset once it is latched. This signal drives a Memory Power Loss indicator in the computer. This control is also used in testing battery under power-up conditions for capability of maintaining standby power.

4.1.3 OVERVOLTAGE PROTECTION

The power supply regulated voltages are protected from overvoltage by crowbar circuits. Table 4-1 lists the overvoltage sensor trigger levels.

Table 4-1. Overvoltage Sensor Trigger Levels

Overvoltage Sensor	Trigger Point	
	Minimum	Maximum
-5V	-5.6 Vdc	-7.0 Vdc
+5V MAIN	+5.4 Vdc	+6.3 Vdc
+5V STBY	+5.6 Vdc	+6.5 Vdc
+12V	+12.6 Vdc	+13.5 Vdc

Figure 4-4 shows the overvoltage protection and power distribution system. As can be seen on all but the +5V MAIN, the output voltage of the regulators

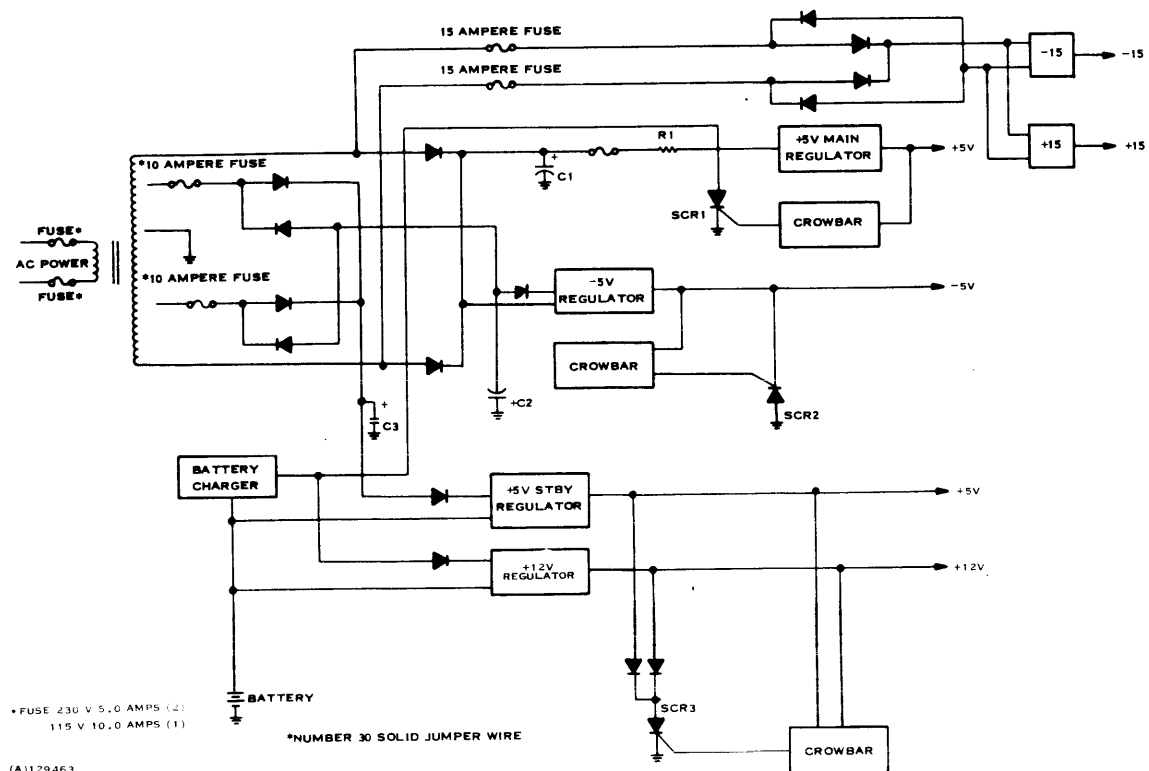

Figure 4-4. Overvoltage Protection and Power Distribution Functional Diagram



is crowbarred. All crowbarred regulators are current limited to prevent burnup. The +5V MAIN is crowbarred by removing the input from the +5V MAIN regulator. Rectifier SCR1 is fired to discharge C1 through R1. This places a heavy but not damaging load on the transformer for not more than 100 milliseconds, the maximum time it takes the 15-ampere fuse to blow.

Outputs of the +5V STBY and the +12V regulators are crowbarred together when one or more of these outputs become too high. The reason these regulators may be crowbarred together is that when any one output is lost, the memory contents are lost or altered.

4.1.4 OVERCURRENT PROTECTION

All regulators are provided with a current limit feature; therefore, each regulator is protected against short circuit or overload conditions.

Current limiting is achieved by sensing current through a resistor in series with the load. A functional diagram of a typical current limited circuit is illustrated in figure 4-5. When the voltage across current sensing resistor R1 becomes large enough to turn on transistor Q1, current is taken away from the base drive of the pass transistor(s). Since the driver supplies less drive to the pass transistor, the pass transistor conducts less, and current limiting is achieved.

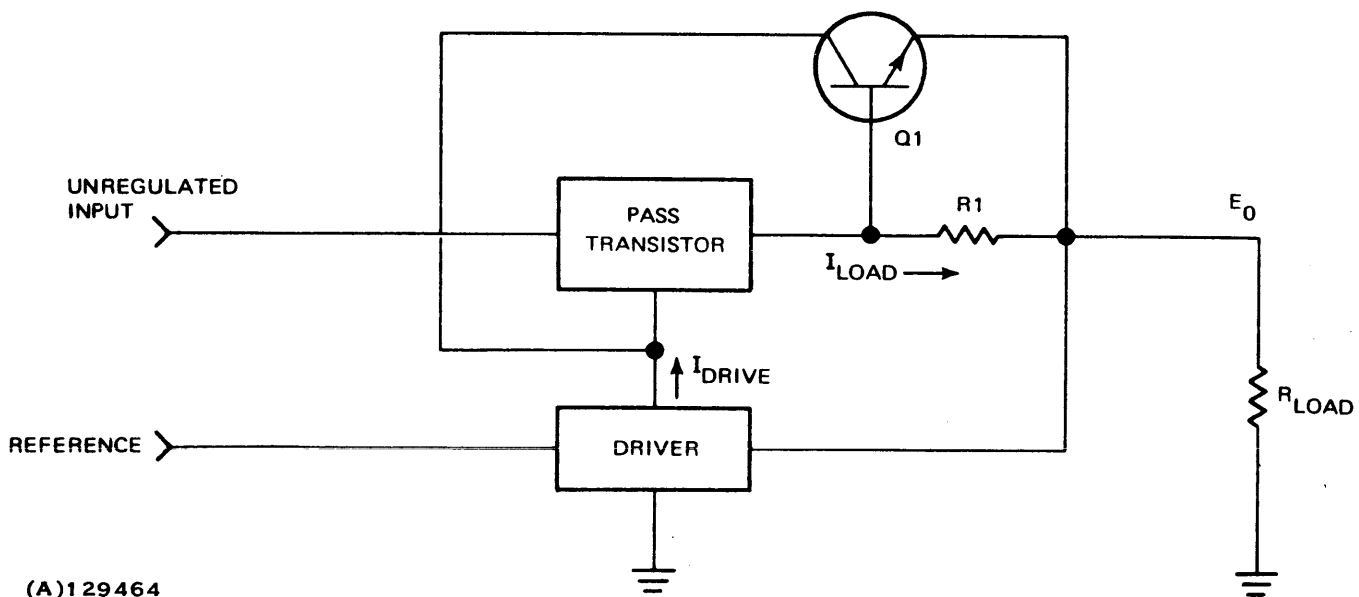

Figure 4-5. Current Limiting Circuitry for Series Regulators



For the +5V MAIN regulator, current limiting is achieved by a similar method (see figure 4-6). The current is sensed by establishing the dc voltage drop across the resistance of L1. As dc current through L1 reaches the value at which the limit is set, the output of the difference amplifier increases linearly. At the predetermined current limit, the output of the difference amplifier is equal to a diode drop above the reference voltage. The voltage comparator responds as though output voltage E_0 is too high and this causes the on-time duty cycle to decrease. When the on-time duty cycle decreases, the delivered current decreases.

4.1.5 BATTERY CHARGING

The power supply contains a circuit for maintaining the battery in a charged condition during normal operation. This circuit ensures that the battery is recharged after discharge. This circuit continually supplies the small current required for normal operation.

The battery is a sealed, jelled electrolyte, lead-acid type. A simplified battery-charging circuit for this type of battery is shown in figure 4-7. The bias voltage that causes conduction in Q2 is developed across Zener diode CR1. A typical Zener voltage for CR1 is 6.2 volts. Transistors Q2 and Q3 form a differential amplifier, with the current through Q2 controlling Q4, which in turn controls pass transistor Q1. Variable resistor R3 is used to adjust the charging voltage.

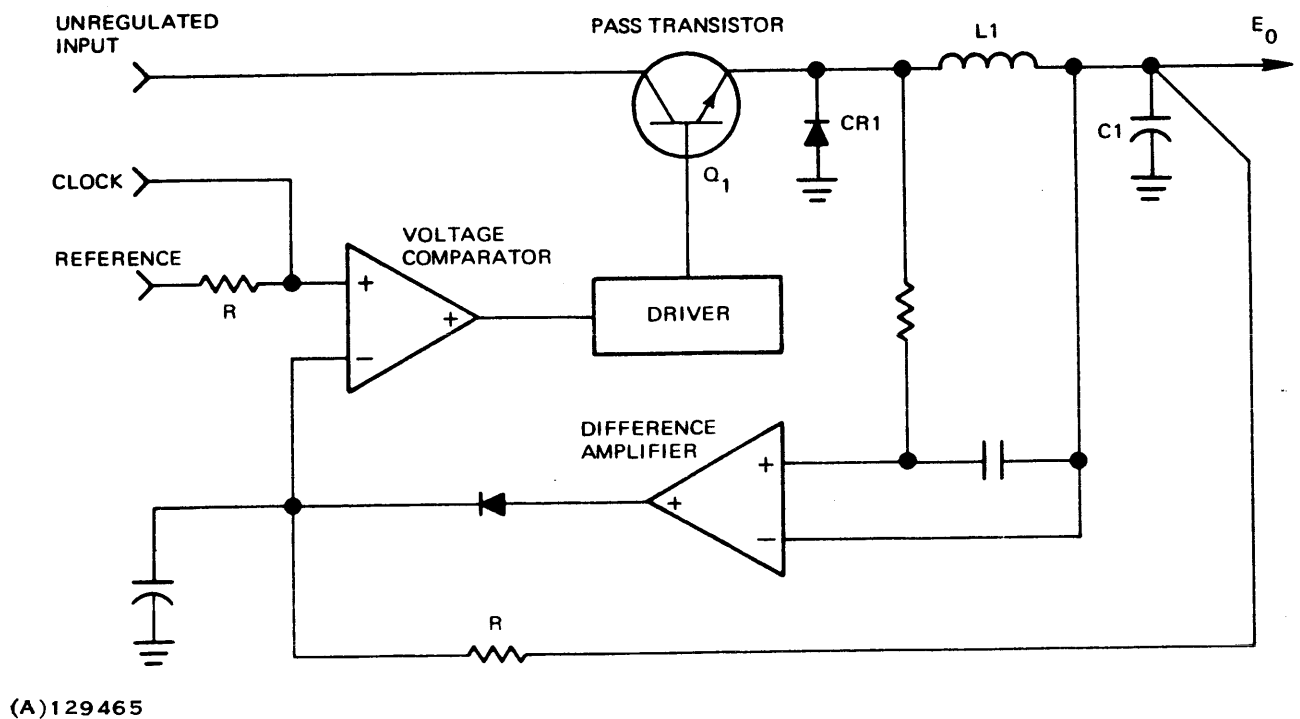
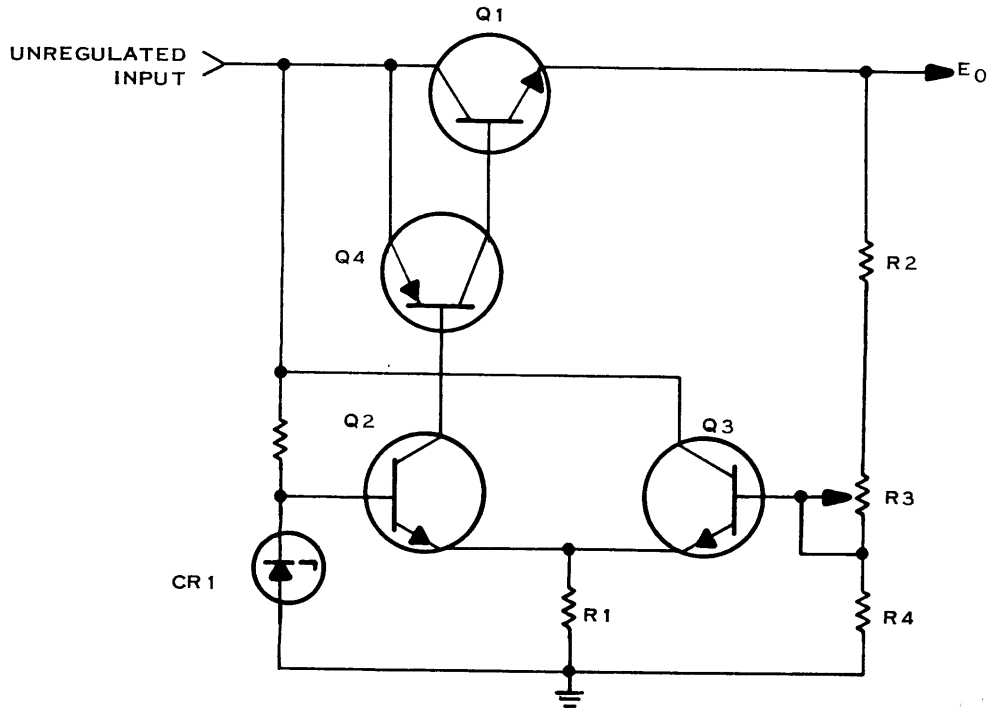

Figure 4-6. Current Limiting Circuit for Switching Regulator



(A)129466

Figure 4-7. Battery Charging System

The charging voltage, E_0 , is developed across R_2 , R_3 and R_4 . If the voltage is too high, the emitter-base voltage of Q_3 will be greater than normal. This causes greater conduction through Q_3 , drawing current from Q_2 . The reduced current through Q_2 , which is also the drive current to Q_1 , decreases the output current Q_1 delivers to the load, therefore decreasing the output voltage.

A block diagram of the principal circuits of the 960B/980B power supply is shown in figure 4-8.

4.2 DETAILED THEORY

Significant circuits in the power supply are described in detail in this section. Details of the regulators, control circuits, overvoltage circuits, overcurrent circuits, auxiliary regulators, and battery charger are covered in this section. Emphasis is given to how the circuits work together.

4.2.1 +5V MAIN REGULATOR AND CONTROL

The +5V MAIN regulator and control board contains the +5V MAIN regulator and overvoltage protector, the clock, ac DETECT circuit, ON-DELAY circuit, reference enable circuit, overload detect circuit, master reset circuit, and power-off circuit. Each of these circuits (Reference TI drawing 943691) is described in a separate paragraph which follows.

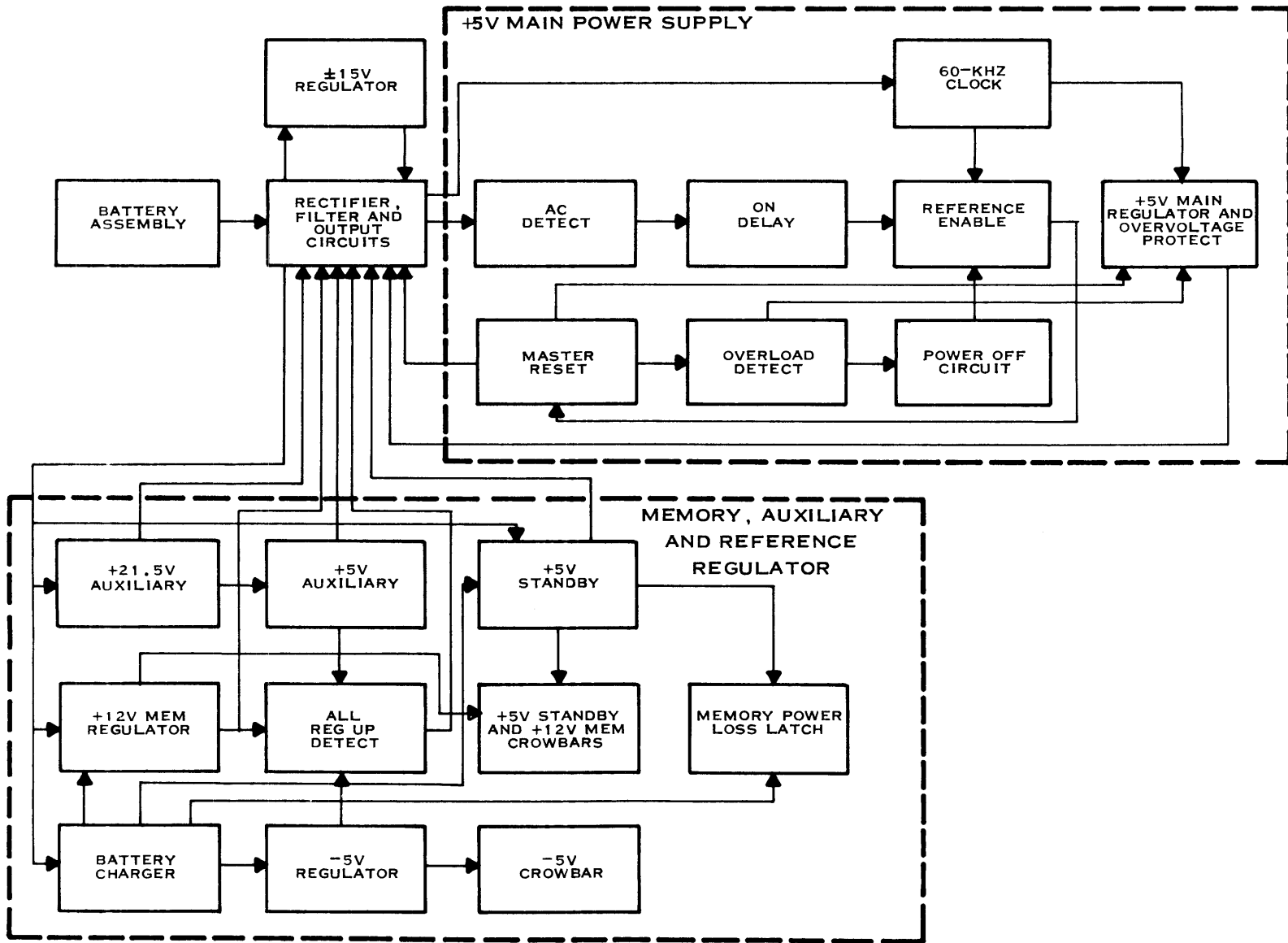

(A)129467

Figure 4-8. Power Supply Block Diagram



4.2.1.1 +5V MAIN REGULATOR AND OVERVOLTAGE PROTECT. The +5V MAIN regulator is a switching regulator. This regulator utilizes one comparator and two switching transistor circuits.

The reference signal (+5V) is fed to the non-inverting input of comparator AR1. Superimposed on this signal is a triangular synchronizing signal. The triangular synchronizing signal is developed by integrating the 60 kHz clock. Components R52 and C21 provide the integration. The resulting triangular signal has an amplitude of approximately 50 millivolts peak-to-peak and is ac coupled through C20 to AR1 pin 2.

The regulator output is remotely sensed on the CPU computer backplane. The +5V SENSE line is fed back to the inverting input, pin 3, of AR1 and is filtered by C22. This signal is compared to the signal at the non-inverting input. When it is less than the signal at the non-inverting input, the output of the comparator goes high. See figure 4-9.

Comparator AR1 is a differential comparator with an open collector output. Resistor R71 is provided as a pullup resistor to the +5V AUX line. The output at pin 7 of AR1 is connected to two open collector input AND gates (U6C, U6D). The other inputs to the two AND gates are connected to $\phi 1$ and $\phi 2$, respectively. $\phi 1$ and $\phi 2$ are the outputs of flip-flop U5B. This flip-flop divides the 60 kHz clock in half. $\phi 1$ and $\phi 2$ serve to alternately enable one switching circuit and then the other.

Since each switching circuit operates the same, only one circuit is described. When the comparator output is a logic one and $\phi 1$ is a logic one, the output at pin 11 of U6D is high (≈ 4.7 Vdc). Transistor Q20 is then turned on and the emitter voltage is about 4.1 Vdc. This produces a Q20 collector current of about 143 milliamps. This current is divided between the base of Q17 and base emitter resistor R38 to cause Q17 to conduct.

When Q17 conducts, Q17 collector current is divided between the base of Q16 and base emitter resistor R39 to turn on Q16. Transistor Q16 is held out of saturation by CR9 and CR10. For Q16 to be saturated, Q16 collector-emitter voltage must be equal to or less than the base-emitter voltage. The three diodes clamp Q16 base voltage to the base voltage of Q17. The base voltage of Q17 is a diode drop below the collector voltage of Q16; therefore, Q16 remains unsaturated.

When Q16 is turned on, a voltage is developed across L2. This voltage is the difference voltage between the output voltage (+5 Vdc) and the supply voltage (+35 Vdc) minus the transistor on voltage (≈ 2 Vdc) or 28 Vdc. The voltage that is developed establishes a linear increase of current in relation to time. This increased current through L2 causes the voltage across the output capacitor on the rectifier, filter and output voltage to increase. When the dc output voltage becomes larger than the voltage at the non-inverting input of AR1, the comparator output goes low and the signal at pin 11 of U6D goes low. This condition turns off Q20 and removes drive from Q17 and Q16; therefore, the pass transistor is cut off.

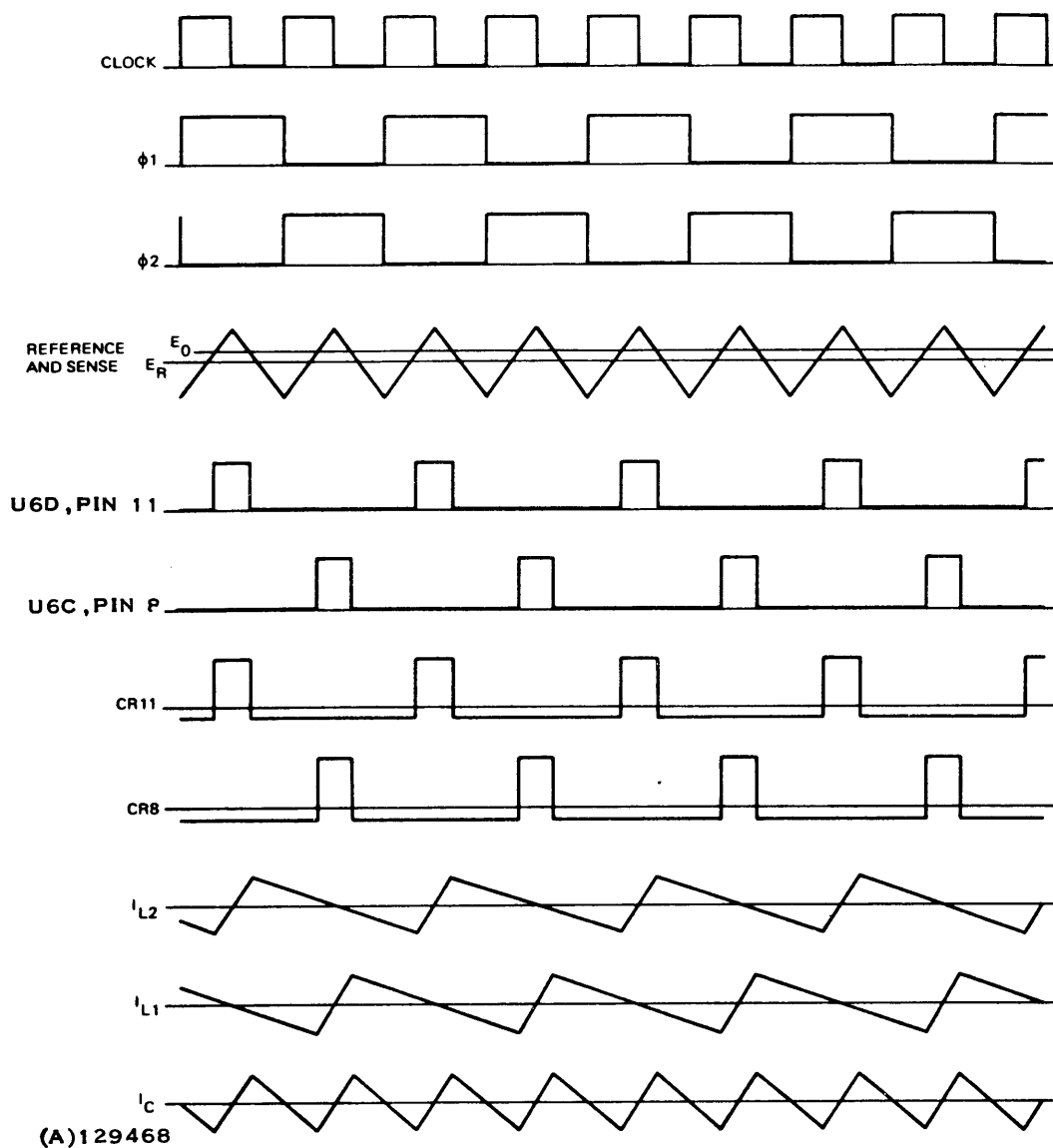

Figure 4-9. Switching Regulator Waveforms

When Q16 turns off, the voltage across the inductor changes polarity. As the voltage on the diode side of L2 crosses zero and becomes negative, CR11 is turned on and conducts. Therefore, the voltage on the diode side of L2 is clamped to the on voltage of CR11 or approximately -1.4 volts. The polarity change across L2 results in a linear current decrease through L2. This condition results in a voltage decrease across the output capacitor.

As the dc output voltage decreases to less than the voltage at the non-inverting input of the comparator, the comparator output goes high. By this time, $\phi 1$ is low and $\phi 2$ is high. The output at pin 8 of U6C is high to turn on Q15. This condition provides drive for the remaining switching circuit. Waveforms for the two switching circuits are shown in figure 4-9.



A damping network consisting of a capacitor in series with two parallel resistors is placed across each commutating diode to eliminate spikes and ringing. Figure 4-10 shows the diode voltage waveform for the case of no external load.

Currents through L1 and L2 are summed into the output capacitor as shown in figure 4-9. This ripple current, I_C , is approximately two amperes peak-to-peak. The output ripple voltage which is the product of this current and the output capacitor equivalent series resistance, should be less than 50 millivolts peak-to-peak.

Current limiting is provided for each half of the switching regulator. Duality is required because of the possibility of one half of the regulator failing and the other half trying to supply all of the current. This would cause a failure in the good regulator half, also. Since both current limiters are identical, only one is explained.

Current is sensed by detecting the voltage drop across the inductor. The dc inductor resistance is 18 milliohms. This resistance varies with temperature such that for a given current through the inductor, the voltage across it varies with temperature. This voltage to temperature variance is taken into account with respect to current limiting. Resistors R43 and R44 form a divider between the diode side of L2 and ground. Thus, the voltage at the junction of R43 and R44 is at +5V when current limiting begins. If the dc current through L2 increases, the voltage across it increases as does the voltage at the junction of R43 and R44.

The voltage difference at the junction of R43 and R44 and the output voltage is the input to the comparator (AR2). This output is coupled through CR15 and R24 to the inverting input of comparator AR1. When the output of AR2 switches, the comparator reacts as if the regulator output voltage is too high and reduces the on-time duty cycle of the regulators.

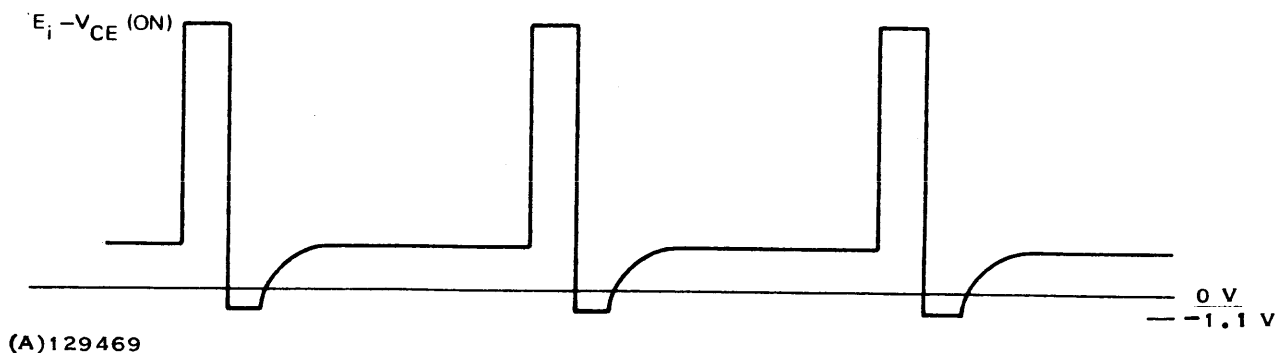

Figure 4-10. Commutating Diode Waveform - No Load



Other components have a definite effect on the operation of the current limiter. Capacitor C17 filters the ac voltage swing on the diode side of L2. This filtering keeps the current limiter from falsely limiting. It may appear that C17 has the wrong polarity. This is not true, however, as the voltage on the negative side of C17 is less than or equal to the voltage on the positive side during normal operation. Only during current limiting conditions is it reversed biased and then by not more than approximately 5.0 millivolts.

The two current limiters possess an OR function such that either or both cause the comparator to decrease the on-time duty cycle.

The +5V crowbar uses Q13 and CR12 as active elements to sense an over-voltage condition. Components R48 and CR12 are connected in series between the +5V SENSE and SENSE GROUND lines. Zener diode CR12 has a nominal voltage of +5.6 volts at 20 milliamperes. The voltage across R48 and CR12 is normally +5 volts so very little current is passed through R48. Therefore, the voltage across R48 is approximately zero. This condition keeps Q13 cut off. As the output voltage increases, the voltage across R48 approaches 0.6 volt to turn on Q13. Transistor Q13 supplies current necessary to turn on the SCR on the rectifier filter and output board. The SCR crowbars the input voltage to the +5V regulator. When the input to the +5V regulator is crowbarred, current cannot be supplied to the output capacitor and the output voltage decreases due to the load. C19 acts to filter the noise. Resistor R47 acts as a current limiter to keep from damaging Q13.

4.2.1.2 60 kHz CLOCK. The 60 kHz clock is generated by an astable multivibrator using Q11 and Q12 as active elements. The frequency is controlled by two RC networks consisting of R30, C9 and R29, C10. The output of the multivibrator is buffered by U6A. This improves the rise time to the clock waveform.

The 60 kHz clock performs three functions:

- a. Triangular synchronizing waveform generation.
- b. Regulator phase signals $\phi 1$ and $\phi 2$ generation.
- c. Clock must be present to achieve +5V REF ramp up. (Reference paragraph 4.2.1.5, Reference Enable Circuit.)

4.2.1.3 AC DETECT. The ac detection circuit provides control for numerous functions in the power supply. These functions include:

- a. Power failure detect.
- b. Start ON DELAY.



When the average voltage at pins 57 and 58 of the +5V MAIN board reaches approximately 24 Vdc, the voltage at the junction of R2 and R3 is approximately 17.5 Vdc. This condition causes approximately 0.5 milliamperes to flow through R3, S1, CR1, and R4. This 0.5 milliamperes turns on Q1 to pull the collector down to zero. The AC ON- signal on the collector of Q1 is used to control the preceding functions.

The AC ON- signal remains low all the time the voltage at pins 57 and 58 is above 24 Vdc. If ac power is lost, the voltage on the +33V line (pins 57 and 58) decreases faster than the voltage on the +35V line. The reason for this is the storage capacity of C3 on the rectifier filter and output board. Typically, AC ON- will go high at about 16 to 18 milliseconds after ac power is lost. It could be as low as 6 milliseconds for minimum line and maximum load conditions or as high as 30 milliseconds for maximum line and minimum load conditions.

Thermistor R81 and associated circuitry protects the power supply from over-heating. If the heatsink temperature rises to about 185° F, the thermistor will reduce in resistance to the point of causing comparator AR2 output to switch; effecting a power supply shutdown. A normal power off cycle will occur with appropriate MRESET- and POF \bar{F} signals. Since the power supply fan is still running, the heatsink will cool down and the power supply will come back on in a normal manner.

4.2.1.4 ON DELAY. The on delay circuit contains logic necessary to delay the reference enable circuit and sufficient logic to allow the storage capacitor to become fully charged. It also resets the overload latch. When ac power comes on, and AC ON- goes low, Q2 is turned off. Its collector voltage rises as C2 is charged through R7. When C2 is charged to approximately 12.6 volts, CR2 is at its nominal zener voltage. The base emitter junction of Q3 is forward-biased by 0.6 Vdc, and Q3 is saturated. This condition pulls the base of Q4 low to turn Q4 off. When Q4 turns off, the collector (ON DELAY-) goes to +4.3 volts. This condition is caused by the pullup resistor R10. There is a test jack J1 on the card for monitoring this signal. Capacitor C2 takes about 500 milliseconds to charge to 12.6 Vdc. This half-second delay is necessary to make sure ac power is up and to allow the auxiliary voltages to stabilize.

If the AC ON- signal goes high, Q2 is turned on and C2 is discharged through Q2. Transistor Q3 is turned off and Q4 is turned on; therefore, the ON DELAY- goes low. This condition initiates POF \bar{F} pulse generation. Figures 4-11 and 4-12 illustrate the timing sequence.

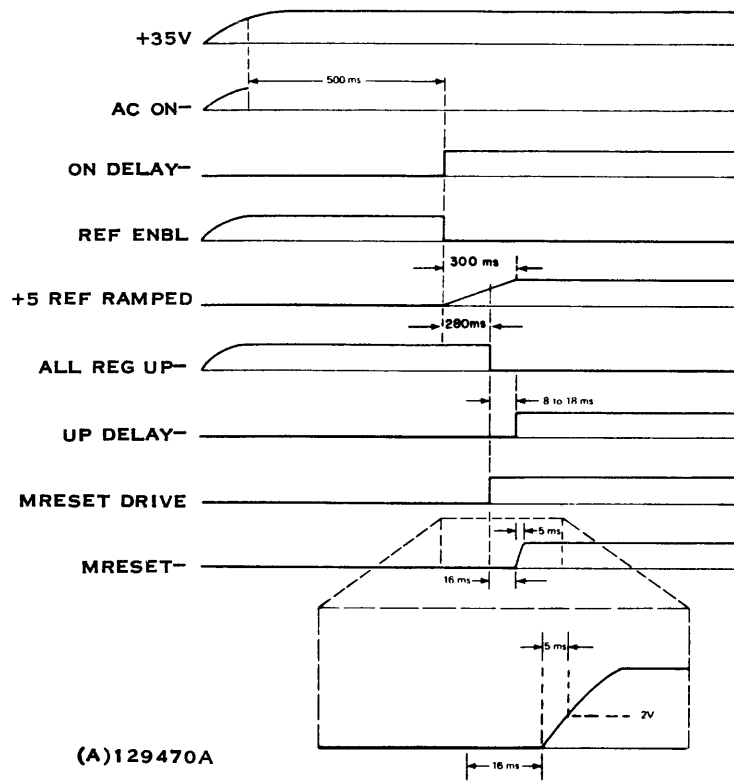

Figure 4-11. Turn-On Sequence Timing

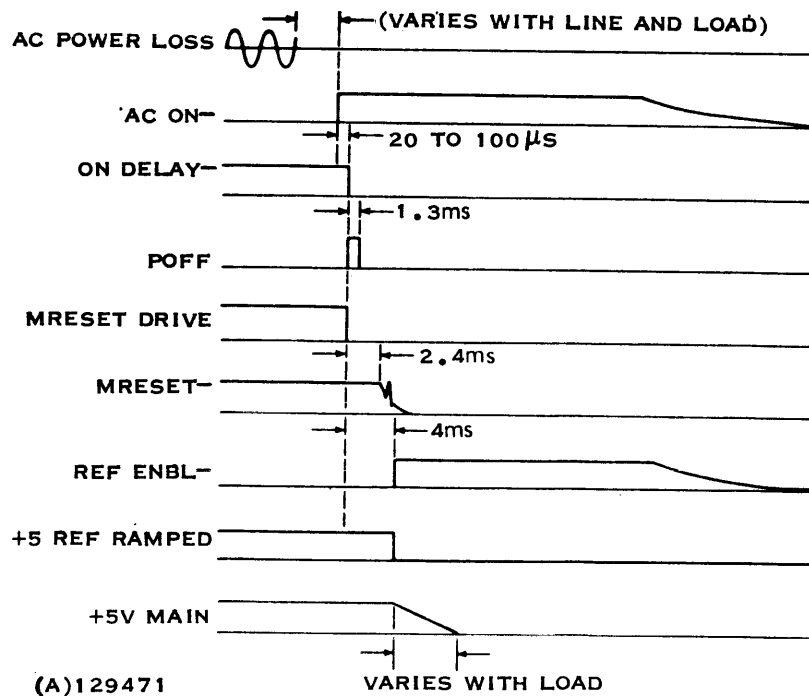

Figure 4-12. Turn-Off Sequence Timing



4.2.15 REFERENCE ENABLE. The reference enable circuit enables the +5V REF to be ramped up or disabled. To shut off the +5V MAIN, the reference is disabled immediately. The mainframe of the reference enable circuit is -UID and Q5.

If either pin 12 or pin 13 of U1D is low, the output at pin 11 is high. This output is called REF ENBL-. When it goes from high to low, Q5 turns off allowing C6 to charge from +35V through R17 and R18. Transistor Q6 acts as an emitter follower. The Q6 output (+5 REF RAMPED) follows the voltage ramp at C6 by six-tenths of a volt. When the voltage at the base of Q6 reaches +5 Vdc, Q6 becomes an inverted transistor switch. As the voltage at C6 rises to 5.6 Vdc, Q6 becomes saturated and the emitter voltage is very near the collector voltage.

The reference is disabled when pin 12 or pin 13 of U1D goes low. This condition allows the output at pin 11 to go high and turns on Q5. This almost immediately turns Q6 off. Resistor R17 provides current limiting to prevent Q5 damage. Pin 9 of U1C goes low when an overload occurs. Pin 13 goes low when the Q output (pin 5) of U5A goes high. This occurs if PRESET (pin 4) is low or if PRESET is high, and D line (pin 2) is high and the CLOCK (pin 3) goes from low to high.

4.2.1.6 OVERLOAD DETECT. The overload detect circuit consists of a bistable latch and a two-input NAND gate. The output of the overload latch is normally high. The overload latch is reset by ON DELAY- when it changes from high to low. For the overload latch to be tripped (i. e., OVERLOAD- goes low), both pins 4 and 5 of U3B must be high.

During the turn-on sequence U3B pin 4 (ALL REG UP-) is initially high and pin 5 of U3B (UP DELAY-) is low as illustrated in figure 4-11. After the +5V MAIN gets up and all other voltages are up, ALL REG UP- goes low. Eight to eighteen milliseconds after this occurs, the UP DELAY- goes high. After this occurs, when a regulator goes below a predetermined level (see table 4-2), ALL REG UP- goes high and the overload latch is tripped. This shuts down the +5V MAIN by making REF ENBL- go high.

Table 4-2. All Regulator Up Sensor Levels

Regulated Voltage	Trip Level
+5V MAIN	+4.7 V \pm 0.03 V
-5V	-4.2 V \pm 0.2 V
+5 STBY	+4.7 V \pm 0.03 V
+12V MEM	11.4 \pm 0.2 V



ALL REG UP- is high when the +5 REF is being ramped up. If the +5 SENSE does not follow the +5 REF RAMPED signal by less than 0.6 volt, Q8 is turned on. This pulls the collector of Q8 up to turn on Q9. The collector of Q9 is pulled to ground. UP DELAY- goes high. Since ALL REG UP- is high and UP DELAY- goes high, the overload latch is tripped. This shuts down the +5V MAIN. The ac power must be turned off and back on to reset the latch.

If there is not an overload condition during +5 REF RAMPED, the +5V MAIN comes up. The voltage across C6 continues to ramp up until clamped by CR3 and the base-emitter diode of Q7 to +5 REF. This turns on Q7 which pulls the base of Q9 up to 0.6 volt. Transistor Q9 is turned on and UP DELAY- goes high. This makes the overload latch ready under power up conditions.

4.2.1.7 MASTER RESET. The master reset circuit generates the MRESET- signal. This signal is used for power supply and computer control.

After ALL REG UP- goes low (U3A - 1, 2) and ON DELAY- goes high (U1B - 5), the output of U1B (pin 6) goes low. This allows C5 to discharge through R14 and the base of Q19. When the base current of Q19 is low enough for Q19 to start coming out of saturation, the feedback action of Q10 and associated components cause Q19 to turn off and MRESET- to go high.

During a power off cycle, ALL REG UP going false causes the output of U1B (pin 6) to turn off. This allows C5 to charge through R13. CR18 is to ensure that the voltage rating of U1B output is not exceeded. As C5 charges, Q19 turns on and Q10 turns off providing feedback action. During battery operation, MRESET is held low by battery base current provided through CR5.

4.2.1.8 POWER OFF. The POFF pulse is generated by one shot U2. Under normal operating conditions, MRESET- is high. This condition makes the input at pin 5 of U2 high. When loss of ac power or a thermal cutout occurs, ON DELAY- goes low causing pin 3 of U2 to go low. There is a delay; therefore, pin 5 of U3 remains high while pin 3 goes low. The one shot is fired and POFF goes high for about 1.3 milliseconds. On-time of the POFF pulse is determined by R11 and C4.

4.2.1.9 TURN-ON SEQUENCE. Turn-on sequence waveforms are shown in figure 4-11. When the ac power comes on, the +35V line and the +33V line increase from zero to their respective values. Also, the auxiliary and reference voltages begin to assume their values. All regulators except +5V MAIN come up unless the power supply is operating in the battery mode. If this is the case, other regulated voltages may already be up depending on the charge left in the battery.



As soon as the voltage across C1 becomes 17.5 Vdc, AC ON- goes low. This starts the ON DELAY- which lasts for about 500 milliseconds. When ON DELAY- goes to zero, it resets the overload latch. Therefore, OVERLOAD- is high. Pins 10 and 9 of U4C are also high; therefore, the input to the D line of the flip-flop is low. The Q output of U5A is preset to a high condition by the ON DELAY-. At this time, pins 12 and 13 of U1D are high and pin 11 is high. This signal is REF ENBL-. When ON DELAY- goes high, the Q output of U5A assumes the signal on the D line when the clock changes from a high state to a low state. A high state now appears at pin 13 of U1D causing the signal at pin 11 of U1D to go low. REF ENBL- goes low to enable the reference.

4.2.1.10 TURN-OFF SEQUENCE. Figure 4-12 illustrates the turn-off sequence waveforms. As soon as the voltage on C1 decreases below +17.5 volts, the ac detect circuit senses ac power loss. The AC ON- signal goes high. The storage capacity of the capacitor on the +35V line is large; therefore, it stays up long enough for all shut-off sequence procedures to occur even for heavy loads.

The ON DELAY- goes low about 20 to 100 microseconds after AC ON- goes high. This initiates the POFF pulse. MRESET- goes low about 2.4 milliseconds after the start of the POFF pulse. About 4.0 milliseconds after the start of the POFF pulse, the +5V MAIN starts to decay.

The turn-off sequence is also initiated for thermal cutout. Thermal cutout occurs when the heatsink temperature rises above an acceptable level.

If turn-off occurs due to regulator overload, (ALL REG UP- going high) the above sequence is bypassed and the reference is disabled without delay.

4.2.2 MEMORY, AUXILIARY, AND REFERENCE REGULATOR

The memory, auxiliary, and reference regulator board contains the +5V STBY and +12V MEM regulators, -5V regulator, +5V REF, auxiliary regulators, battery charger, ALL REG UP detect circuit, memory power loss latch, and overvoltage protectors for all regulated voltages except +5V MAIN. Each of these functions is discussed in a separate paragraph which follows. (Refer to TI drawing number 943695.) This board also contains the ±15V regulator, discussed in paragraph 4.2.3.



4.2.2.1 +5V STANDBY AND +12V MEMORY REGULATORS. The +5V standby (STBY) and +12V memory (MEM) regulators are similar. The +5V STBY regulator is described in detail. Only the differences between the +5V STBY and the +12V MEM regulator are discussed for the +12V MEM regulator.

The +5V STBY regulator depends on AR1, which is an integrated circuit voltage regulator. AR1 supplies drive current to Q13, which in turn supplies drive to Q12. Q12 supplies drive to Q11 in the normal power-on mode. Feedback to AR1 is supplied through the resistor group R23, R98 and R24. R98 allows voltage adjustment of the regulator output. Resistors R22, R20 and R21 set the regulator current limit and foldback current limit.

In the standby mode, the +9V line goes to zero and the standby power is supplied from the battery.

The +12V MEM regulator operates in the same manner as the +5V STBY. The circuits are identical except for component values.

4.2.2.2 -5V REGULATOR. The -5V regulator uses a multivibrator, consisting of transistors Q20 and Q23 and components CR10, C10, CR13 and C11, to drive transistors Q24 and Q35, which act as switches. When Q24 is turned on, C15 is charged to near the battery voltage. Q24 is then switched off, and Q35 turns on, dumping the charge on C15 into C16, giving a negative output voltage to the zener-controlled emitter follower regulator composed of Q45 and CR27. The -5V output is obtained at the emitter of Q45.

4.2.2.3 +5V REFERENCE AND +5V STBY/+12V MEM CROWBAR REFERENCE POINT. The +5V REF begins with the +21.5V AUX regulator. Components R28 and CR8, a temperature-compensated reference diode, form a pre-regulator for 6.2 volts ± 5 percent. Potentiometer R29 and resistor R30 are connected across this pre-regulator. The wiper of R29 is connected to the non-inverting input of AR2. AR2 is connected as a times one non-inverting amplifier. The AR2 output is +5V REF and is adjusted by moving the wiper along R29.

The +5V REF is used as a reference for the +21.5V AUX regulator, the +5V AUX regulator, and the +5V MAIN regulator.

The +21.5V AUX line and the BAT+ line, a dual power source, are connected to a pre-regulator by diodes CR15 and CR16, respectively. The pre-regulator consists of R48 and CR17. CR17 is a low-voltage avalanche diode. Potentiometer R63 and resistor R64 are connected across the pre-regulator. The R63 wiper is the output for the +5V STBY/+12V MEM crowbar reference point. This reference is designed for very low current operation for use during standby operation.

The crowbar reference point provides reference for the crowbar circuit for the +5V STBY and +12V MEM regulators.



4.2.2.4 AUXILIARY REGULATORS. Auxiliary voltages are generated in the power supply for operation of the supply.

The +21.5V AUX regulator is similar to other regulators in the power supply that use a difference pair of transistors as an amplifier. A reference is first established by R3 and CR1. This reference voltage is approximately +4.3 volts and is fed to the base of Q4 through CR2. As the voltage of the +21.5V regulator comes up the +5V REF comes on. This reference is fed to the base of Q4 through resistor R6. This voltage back-biases CR2 and the reference formed by R3 and CR1 is no longer necessary.

Transistors Q4 and Q5 form the difference pair for the +21.5V regulator. The output voltage is fed back to the base of Q5 by resistive dividers R16 and R17. When the output voltage is at +21.5 volts, the voltage at the base of Q5 should be at +5 volts. Resistor R7 sets the current to the difference pair. This current is approximately 6 milliamperes. When the bases of Q4 and Q5 are at the same voltage, the collector current of each transistor is approximately equal. If the output decreases below +21.5 volts, the base of Q5 decreases below +5 volts. This decrease causes an increase of Q4 collector current and a decrease of Q5 collector current. Therefore, more drive current is available to Q2. Thus, more drive is available to pass transistor Q3; therefore, Q3 conduction increases and the output voltage increases until the base of Q5 returns to +5 volts. When the output increases, the opposite effect occurs; i. e., Q4 current decreases, Q5 current increases, and less drive is available to Q3 to reduce Q3 conduction. Thus, the output voltage decreases until the base of Q5 returns to +5 volts.

The +5V AUX regulator input is +21.5 volts. This regulator uses the +5 REF as a reference. The +5V AUX regulator uses a technique similar to the difference pair method. Diode CR12 acts as the other transistor of the pair. Resistor R51 sets the current to Q19 and CR12 to 6 milliamperes. When the output is low, Q19 conduction increases and CR12 conduction decreases. This condition supplies more drive to the two parallel pass transistors, Q17 and Q18. The conduction of Q17 and Q18 increases so the output voltage rises to the desired level. If the output voltage rises too high, CR12 conduction increases and Q19 conducts less; therefore, the pass transistors conduct less and the output voltage decreases to +5 volts.

The two pass transistors of the +5V AUX regulator are designed to share current by use of effective emitter resistors R35, R36, R37 and R38. These emitter resistors also protect the pass transistors in case the output is shorted.

4.2.2.5 BATTERY CHARGER. The battery charger operation begins with a bias voltage being developed at the cathode of CR3. This reference is



fed through R12 to the base of Q9. R26, R92 and R27 form a voltage divider between the output from pass transistor Q7 and ground. The base of Q10 is connected to this divider. Potentiometer R92 allows adjustment of the voltage applied to the base of Q10. This voltage may be varied to be from 22 to 37 percent of the output voltage. Transistors Q9 and Q10 form a difference pair with available current set by the reference and R19. Current from Q9 drives Q8 and thus, Q7, the pass transistor. The output current passes through CR9. Diode CR9 prevents battery current from returning into the charger during standby operation. Current limiting is provided by Q6 and parallel resistors R8 and R9. A low battery is normally charged with the regulator in current limit (0.6 ampere) until the battery reaches the regulator output voltage. After this, the output voltage is constant and the current decays approximately exponentially to a very small value. This decay is due to the internal characteristics of the battery.

4.2.2.6 ALL REGULATORS UP DETECT. The all regulators up detect circuit senses the output voltages from the regulators (with the exception of the internal $\pm 15V$ regulator). The output of this detect circuit is called ALL REG UP-. As implied by the output signature, the output level is low when all regulators are up. If one or more regulators go low after all have been up, the ALL REG UP- line goes high as noted in table 4-2. When the ALL REG UP- goes high, the +5V MAIN is shut down immediately.

There is a voltage divider between the +21.5V line and the +5V REF line consisting of R57 and R58. This divider sets the base voltage for Q26. There is also a divider between the +5V REF and ground. This divider consists of R59 and R60 which set the base voltage for Q27.

Assuming that all regulators are up, transistors Q26 and Q27 are biased on by the voltage dividers composed of R57, R58, R59 and R60. The emitters of Q26 and Q27 are a diode drop above their respective bases. Since the output voltages are up, diodes CR14, CR20 and CR21 are back-biased. As a result of Q27 being on, Q36 is turned on. The collector of Q36 (ALL REG UP-) is pulled to ground. When Q27 is turned off, the ALL REG UP- signal goes high. Transistor Q27 is turned off when the available current at the emitter is cut off. For example, the base of Q28 normally sits at +0.2 volt. When the -5V line goes to -4.2 volts, the base of Q28 rises to 0.6 volt. Thus, Q28 is turned on to divert current that is normally available to Q27. Hence, Q27 is cut off. If the +5V SENSE line drops to +4.7 volts, CR21 is forward biased to divert current from Q27. Likewise, if +5V STBY drops to +4.7 volts, CR20 is forward biased to divert current from Q27. When the +12V MEM line drops to 11.5 V, CR14 is forward biased to turn off Q26 and Q27. Therefore, any or all of these regulated voltages are capable of tripping the all regulators up detect circuit.

4.2.2.7 MEMORY POWER LOSS LATCH. The memory power loss latch consists of a detector, bistable latch, indicator drive, and reset circuit.



The memory power loss detector performs two functions: to detect memory power loss and to detect low battery voltage during ac power up conditions. The detector consists of difference pair Q21 and Q22. The base of Q21 is connected to the +5V STBY through R46. The base of Q22 is connected to a resistor divider from the positive battery line to ground. The divider consists of R65 and R66. Transistor Q22 conducts when the base of Q22 is equal to or less than the base of Q21. This condition enables the detect circuit to trigger the latch for battery voltages of +20.1 volts.

■ When Q22 starts to conduct, the voltage across R50 rises until Q32 is turned on. This condition sets the latch consisting of Q33 and Q34. Transistors Q33 and Q34 are connected to function as a silicon controlled rectifier (SCR).

When Q32 is turned on, Q32 collector pulls the base of Q34 to ground. Thus, Q34 and Q33 cease to conduct and are turned off. When the battery voltage comes back up, Q22 is turned off. Likewise, Q32 is turned off. Transistors Q33 and Q34 remain cut off; therefore, Q40 is biased off allowing the collector to rise until Q41 is turned on. Thus, the Q41 collector is pulled to ground to drive a light-emitting diode on the computer front panel. With the light-emitting diode (LED) turned on, the user of the computer knows that the battery has fallen below the value necessary to maintain voltages for the memory.

A RESET switch is located on the computer. When this switch is pressed, the RESETSW- goes to ground and Q42 is turned on to pull the Q34 collector down to +2 volts. Current for Q42 is supplied through R76 to turn on Q33. When Q33 is turned on its collector current flows into the base of Q34 and resistor R77, turning on Q34. The SCR connected transistors are therefore turned on. Transistor Q40 conducts and pulls the base of Q41 to ground to turn off Q41 causing the LED on the computer front panel to turn off.

During ac on operation, the battery capacity is tested by loading the battery with a one-ampere load. If the battery voltage falls below +20.1 volts, the power loss latch is set. A switch on the rear of the power supply chassis provides this load.

■ 4.2.2.8 BATTERY SAVE CIRCUIT. The Battery Save Circuit turns off the battery by means of a transistor switch (Q43) whenever battery voltage is less than approximately 21.5V. The MEMORY PROTECT LOSS (MP LOSS) latch is set simultaneously, giving the operator an indication that the battery has been turned off and memory is lost. When AC power is restored the battery save latch is reset.



A voltage comparator (Q21 and Q22) compares battery voltage and approximately 21.5V. The circuit uses +5 STBY voltage for reference. When the battery voltage is below 21.5V, Q32 sets both the MP LOSS latch (Q33 and Q34) and the battery save latch (Q38 and Q39). These latches are supplied directly from the battery, thus maintaining their state during battery save operation. The battery save latch operates a transistor switch (Q45 and Q43) to turn off the battery from the regulator circuitry. When AC power is reapplied, +5 REF resets the battery save latch, turning the battery on. The MP LOSS latch remains latched until reset from the front panel.

4.2.2.9 OVERVOLTAGE PROTECTION. Overvoltage protection for the memory, auxiliary, and reference regulator uses a crowbar type circuit to pull the regulator voltages down. One crowbar is provided for the -5V regulator. Another is provided for the +5V STBY and +12V regulators. If either of these voltages is too high, then the crowbar reacts on both voltages.

The -5V crowbar uses CR32 and R87 to sense overvoltage. When the -5V swings more negative, CR32 zener action occurs. At approximately -5.6 volts output, the voltage across R87 is approximately 0.6 volt turning on Q44. The voltage across R89 rises and turns on the SCR, CR33, pulling the -5V output down to the SCR on voltage. Power must be turned off and then on to turn off the SCR.

The crowbar for the +5 STBY and +12 MEM regulator is provided by a single SCR which can be triggered by either of two trigger circuits. Each trigger circuit (one for +5 STBY and one for +12 MEM) consists of a reference zener diode(s) and a trigger transistor. When the supply voltage exceeds the reference voltage +.6V, the SCR turns on, forcing the output to zero. Power must be turned off and then on to turn the SCR off again.

4.2.3 ±15 VOLT REGULATOR

The ±15 volt regulator circuit, located on the Memory, Auxiliary and Reference Regulator Board, contains the input rectifiers, filters and regulator circuits required to produce +15 Vdc and -15 Vdc outputs. Three-terminal regulator AR4 generates the +15 volt output, while three-terminal regulator AR5 produces the -15 volt output. Each regulator is both thermally and short-circuit protected. Components Q46, CR38, CR39 and R95 reduce the input voltage to AR4 to prevent the input voltage from exceeding the voltage breakdown limits of AR4. Components Q47, CR40, CR41 and R94 reduce the input voltage to AR5.

4.2.4 RECTIFIER, FILTER, AND OUTPUT

The rectifier, filter, and output board contains rectifiers and filters for the basic unregulated power supply voltages. This board has connections for the transformer secondary windings plus connections for the battery. (Circuitry is illustrated in TI drawing 943684). This board contains interconnections between two other power supply cards. One of its main functions is to act as a plug for the power supply. This printed circuit card, mounted in the power



supply chassis, plugs into the computer backplane. All regulator outputs and control signals are delivered to the computer through this card. The output capacitor as well as the crowbar system for the +5V MAIN is contained on this card.

4.3 LOGIC CONTROL SIGNALS

The logic control signals used in the power supply are summarized in this paragraph.

- AC ON- This signal is low when ac input power is applied to the power supply. It is used for detection of power failure and starting the ON DELAY logic circuit.
- ALL REG UP- This signal goes low after the +5 MAIN voltage is up and all other regulated voltages are up. It goes high if a regulator voltage falls below a predetermined level. The All Regulators Up Detect circuit senses the output voltages from the regulators, except the $\pm 15V$ regulator.
- MPLOSS- This control signal is pulled to ground when the battery voltage falls below the value necessary to guarantee maintenance of standby power.
- MRESET- This signal, the master reset signal, remains at logic zero until all voltages stabilize. It becomes logic one when they have stabilized, and is at logic one under normal operating conditions.
- ON DELAY- This signal prevents the +5V MAIN voltage from coming up during the turn-on sequence. It goes low if ac power is lost or a thermal cutout occurs. It resets the overload latch when it goes to zero.
- OVERLOAD- This signal indicates the condition of the overload latch.
- POFF This pulse is generated when ac power is lost. The pulse typically occurs 16 to 18 milliseconds after power loss. It is initiated by MRESET DRIVE.
- REF ENBL- When this signal, the reference enable signal, goes high, it shuts down the +5V MAIN voltage.
- RESETSW- This signal goes low when the RESET switch is pressed and extinguishes the PLOSS indicator.



UPDELAY-

This signal goes high 8 to 18 milliseconds after ALL REG UP- goes low. After this occurs, the over-load latch will be tripped when a regulated voltage falls below a predetermined level.



SECTION V MAINTENANCE

5.1 INTRODUCTION

This section contains preventive maintenance procedures and instructions for checkout, inspection, test, and repair of the power supply. These instructions include test routines that isolate malfunctions to the circuit level. Drawings in Section VI of this manual aid in locating parts that have failed within the power supply. If unable to locate the source of trouble in the power supply, remove the power supply from the computer as specified in Section II of this manual, and return it to the factory for servicing by factory-trained technicians.

5.2 PREVENTIVE MAINTENANCE

A conscientiously applied program of preventive maintenance will help extend equipment lifetime and achieve maximum equipment performance. Preventive maintenance for the power supply includes periodic cleaning of the air filter at the rear of the power supply and regular performance of a battery test to ensure that the battery option is operating properly. The following paragraphs describe these procedures.

5.2.1 CLEAN AIR FILTER

The power supply fan supplies cooling air not only to the power supply, but to the entire computer chassis. A filter at the rear of the power supply removes particles from the air before the air circulates throughout the computer. If the filter element becomes blocked with dust and lint, the volume of air moved through the computer is greatly reduced. This reduction in air flow can cause damage to the power supply or computer components due to overheating. Therefore, regular cleaning of the filter element is essential to proper computer operation. Frequency of cleaning is determined by individual site conditions.

5.2.1.1 POWER ON. If the power supply is operating, clean the air filter using a vacuum cleaner to remove most of the dust and lint from the filter.

5.2.1.2 POWER OFF. If the unit can be powered down, a more thorough cleaning of the filter is possible. Perform the following procedure to clean the filter.

**WARNING**

Do not remove filter element while fan blade is rotating. Failure to observe this warning could result in personal injury or damage to the fan assembly.

1. Set the Power switch on the power supply to OFF and wait for the fan blades to stop rotating.
2. Remove filter element from power supply assembly.
3. Clean filter element in tap water and dry thoroughly.
4. Replace filter element in power supply.
5. Return Power switch to the ON position.

5.2.2 BATTERY CHECK

If the computer is equipped with the optional battery pack, this battery should be checked regularly to ensure that memory will not be lost in the event of a primary power failure. Two separate tests check the operation and condition of the battery. The internal check detects a low battery voltage condition. The external check determines the exact level of battery voltage as a measure of the battery condition. If the battery has been recently discharged by a long-term power failure, charge the battery for a minimum of 12 hours before performing either battery check.

5.2.2.1 INTERNAL BATTERY CHECK. The power supply contains a circuit for detecting low battery voltage while ac power is on. Perform the following steps to exercise this test option:

CAUTION

Do not perform this check if memory contents are valuable. Memory will be lost if battery fails this test.

1. Ensure that the Power and BATTERY switches are in the ON position.
2. Press and hold the BATTERY TEST pushbutton for one minute, and then release the pushbutton.
3. If the POWER LOSS indicator on the control console lights, the battery is not capable of maintaining memory during a power loss situation. Ensure that the battery has not recently been discharged, and then perform the battery charger check procedure in this section of the manual.



4. If POWER LOSS indicator on the control console does not light, the battery has sufficient power to maintain memory during a power loss situation.

5.2.2.2 EXTERNAL BATTERY CHECK. Use a digital voltmeter to measure the voltage as indicated. Perform the following steps to determine the condition of the battery.

1. Ensure that the Power and BATTERY switches are in the ON position.
2. Connect voltmeter probes through the rear of plug P1 (from the battery pack) to contacts 3 and 5. The voltage level should be 27.4 ± 0.6 volts. An excessive reading indicates overcharging; a low reading indicates that the battery is being charged, that it has a bad cell, or that the charger will not charge it to full capacity.
3. If the voltage reading deviates from the specified value, ensure that the battery has not recently been discharged, and then perform the battery charger check procedure in this section of the manual. If the voltage reading is as specified, proceed to step 4.
4. Two options are provided to test the battery under load: one with the BATTERY switch in the ON position, the other with the BATTERY switch in the OFF position. Figure 5-1 illustrates the decision path and requirements for each option. Note that if the BATTERY switch is ON, memory is lost if the battery fails the test; if the BATTERY switch is OFF, memory is lost if primary power fails during the test. Select the position of the BATTERY switch that meets the requirements of the situation.
5. Connect voltmeter probes to the two terminals of one of the batteries in the pack.
6. Press and hold the BATTERY TEST switch for one minute.
7. The voltage reading of the battery should be 13.7 ± 0.3 volts.
8. Repeat steps 5 through 7 for the other battery in the pack.

Battery life is limited. After three years a battery retains only 70 percent of its rated capacity, and only 40 percent after five years. Replace batteries as required to maintain the desired level of memory protection.

5.2.2.3 BATTERY CHARGER CHECK. If the battery checks indicate that the battery is weak, perform the following check of the battery charging circuit before deciding to replace the battery.

1. Ensure that the Power and BATTERY switches are in the ON position.
2. Remove P1 from connector J1 at the rear of the power supply.

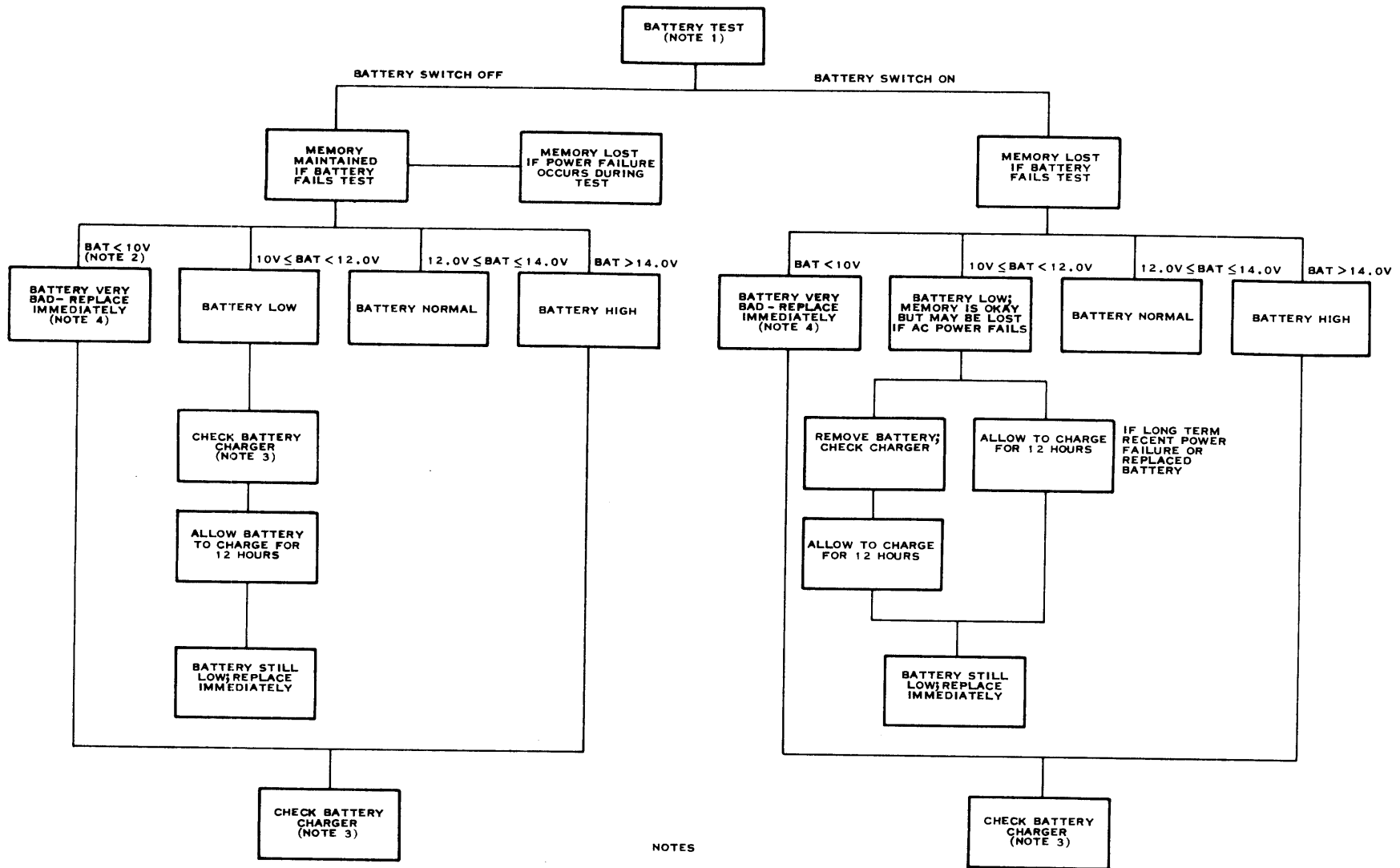

NOTES

- 1. < LESS THAN, ≤ LESS THAN OR EQUAL TO, > GREATER THAN, BAT INDICATES BATTERY VOLTAGE
- 2. VOLTAGE READINGS ARE FOR EACH BATTERY
- 3. CHARGER OUTPUT CAN BE OBTAINED ON PINS 3(+) AND 5(-) OF J1 ON THE POWER SUPPLY CHASSIS WITH THE BATTERY SWITCH CLOSED AND BATTERY DISCONNECTED.
- 4. UNLESS RECENT LONG TERM POWER FAILURE

Figure 5-1. Battery Test Chart

(B) 129297



3. Use a digital voltmeter to measure the voltage across pins 3 and 5 of connector J1. The voltage should be 27.4 ± 0.6 volts.
4. If the voltage reading deviates from the specified range, perform fault isolation procedures in this section to locate the problem area.
5. If the voltage reading is within tolerance and previous battery checks were out of tolerance, replace battery.
6. Reconnect plug P1 to connector J1 at rear of power supply.

5.3 TEST EQUIPMENT

A list of recommended test equipment is provided in table 5-1. Applicable Texas Instruments electrical and mechanical drawings are in Section VI of this manual.

Table 5-1. Test Equipment for Power Supply Maintenance

Item	Specification
Oscilloscope	Tektronix, Type 551 or Equivalent
Dual Trace Preamplifier	Tektronix, Type 1A1 or Equivalent
X1 Probe	Tektronix, Type P6011 or Equivalent
X10 Probe (2)	Tektronix, Type P6012 or Equivalent
Digital Voltmeter	Hewlett/Packard 3440A or Equivalent
Volt-Ohm Meter	Triplett Model 630-NA or Equivalent
Extender Card	Texas Instruments Part No. 226853-0001

5.4 TROUBLE ANALYSIS

This section contains information for locating trouble in the power supply. Circuit diagrams are included in Section VI as an aid for locating parts that have failed.

Before the trouble analysis procedures are implemented, be certain to review the caution notes listed below.

CAUTION

- The power supply should be removed from the computer mainframe for all trouble analysis. Performing trouble analysis while the power supply is connected to the computer can cause damage to other system components. If power supply trouble analysis is to be performed in the computer mainframe, remove all computer PC cards to prevent possible damage to the cards.



NOTE

To allow the power supply to come up when the +5V MAIN board is removed from the CPU chassis, jumpers must be installed as follows:

1. Across R32
 2. Across R33
 3. From negative end of C11 (local common ground) to R32 (ground).
- The ac power is exposed when the power supply cover is removed. Turn the ac power OFF at the source before removing the power supply cover. Disconnect the fan, located on this cover, from the ac terminals. Do not operate the power supply at rated load when the power supply cover is removed because of the lack of sufficient cooling air.
 - Regulator cards are keyed to prevent incorrect insertion. Do not insert or remove printed circuit cards until power to the power supply is turned off. Before proceeding, visually inspect the power supply. Check that both cards fit properly.
 - When using the extender card, be sure that the cards are installed properly. Confirm that the two cards are in the proper locations. (The +5V main card goes into the top printed circuit card slot and component sides of both regulator boards face the transformer.)
 - Insulate all clip leads and test probes to prevent accidental shorting of components.
 - The power supply output plug (rectifier, filter, and output board) contains ± 35 Vac. Pins 21 and 22 contain +35 Vac and pins 19 and 20 contain -35 Vac. These points are exposed on the computer backplane and on the rectifier, filter, and output board when the supply is unplugged. Serious shock may result from contact with either of these points.



The first step during power supply trouble analysis is to determine the general type or location of the failure (see table 5-2). The next step is to determine which card or assembly has failed and then locate the failed circuit or component. (See table 5-3.)

Table 5-2. Failure Types

Symptom	Fault(s)	Trouble Location (Reference: Table 5-3)
Power supply blows secondary or primary fuses	<ul style="list-style-type: none"> a. Rectifier shorted b. SCR shorted c. Filter capacitor shorted d. +5V MAIN crowbar failure e. +5 MAIN regulator failure f. Logic network failure 	Steps 1 through 9
Power supply blows primary fuses	<ul style="list-style-type: none"> a. Fan shorted b. Transformer shorted 	Steps 10 and 12
Power supply does not sequence on		
1. +5V MAIN does not come up at all	<ul style="list-style-type: none"> a. Line voltage low b. +35V low or missing c. Auxiliary or reference voltage missing d. AC DETECT failure e. ON DELAY failure f. 60 kHz clock failure g. Reference enable failure h. Logic network failure 	Steps 13 through 19
2. +5V MAIN comes up part way and is shut down	<ul style="list-style-type: none"> a. +5V MAIN overloaded b. Overcurrent limit failure c. +5V MAIN failure d. Logic network failure 	Steps 20 through 26
3. +5V MAIN comes up all the way and is shut down	<ul style="list-style-type: none"> a. Overload on any regulator b. Standby crowbar fired c. Overload on -5V d. Logic network failure 	Steps 27 through 33



Table 5-2. Failure Types (Continued)

Symptom	Fault(s)	Trouble Location (Reference: Table 5-3)
4. +5V comes up and stays but MRESET- not generated	a. MRESET circuit failure b. Logic network failure	Steps 34 through 36
Power supply does not sequence off	a. Overload latch set b. ALL REG UP failure c. MRESET- failure d. REF ENBL- failure e. POFF failure f. Logic network failure	Steps 37 through 42
Power supply sequences off with ac power on	a. Low line voltage b. Thermal cutout c. Logic network failure	Steps 43 and 44
Power supply overvoltage protection failure	a. SCR failure b. SCR drive failure	Step 45
+5V MAIN has excessive ripple	a. Output capacitor loose or failure b. Inductor failure c. Commutating diode failure d. Logic network failure	Steps 46 through 48
+5V MAIN does not regulate	a. Regulator failure b. Output capacitor loose or failure c. Commutating diode failure d. Inductor failure e. +5V reference failure f. Logic network failure	Steps 49 through 52
Regulator output will not adjust	a. Regulator card failure b. Reference failure	Steps 53 and 54
Battery charger over- or undervoltage	a. Regulator failure b. Sense diode failure	Steps 55 and 56
Battery fuse blows	a. Battery circuit shorted b. Battery charger failure	Steps 57 and 58



Table 5-3. Failure Location

Step	Procedure										
1	With power supply turned OFF and unplugged, remove the +5V main regulator and control (+5V MAIN) board and the memory, auxiliary, and reference regulator (MARR) board.										
2	Check rectifier, filter, and output (RFO) board for shorted rectifiers, CR1 and CR2. Confirm that SCR1 or C3 are not shorted. Replace any shorted components.										
3	Check +35V line on each regulator board for shorts.										
4	Check +5V MAIN board to see if Q13 is shorted or if CR12 is shorted or leaky. Replace if necessary.										
5	Check to see if C5 on RFO board is loose or open. Reconnect it if necessary.										
6	Check Q14 and Q16 on the +5V MAIN board for shorts. Replace if necessary.										
7	Connect clip lead across C6 on +5V MAIN board. This disables +5REF RAMP. Plug MARR board into the power supply and an extender into +5V main slot. Plug +5V MAIN board into extender.										
8	<p>Connect power cord to proper ac outlet and turn power supply ON. Using an ac coupled oscilloscope to monitor outputs for oscillations, check the +5V MAIN board for +21.5V AUX, +5V AUX, -4.3V, and +5 REF. These voltages are to be measured with respect to the logic common (LC) with a digital voltmeter and are located at following points on +5V MAIN board:</p> <table data-bbox="617 1339 1312 1518"> <tbody> <tr> <td>+21.5V AUX</td> <td>Pins 45 and 46</td> </tr> <tr> <td>+5V AUX</td> <td>Pins 43 and 44</td> </tr> <tr> <td>+5V REF</td> <td>Pins 47 and 48</td> </tr> <tr> <td>-4.3V</td> <td>Anode of CR18</td> </tr> <tr> <td>LC</td> <td>Pins 49, 50, 51, and 52</td> </tr> </tbody> </table>	+21.5V AUX	Pins 45 and 46	+5V AUX	Pins 43 and 44	+5V REF	Pins 47 and 48	-4.3V	Anode of CR18	LC	Pins 49, 50, 51, and 52
+21.5V AUX	Pins 45 and 46										
+5V AUX	Pins 43 and 44										
+5V REF	Pins 47 and 48										
-4.3V	Anode of CR18										
LC	Pins 49, 50, 51, and 52										
9	Turn power OFF; remove +5V MAIN board. Remove clip lead across C6. Lift emitter side of R57 and R58. Connect clip lead between logic common and collector of Q7 (can is in electrical contact with collector). Reinsert +5V MAIN board and turn ON power supply. Signal at base of Q15 and Q20 is a square wave with an amplitude of approximately 4.7V and period between 30 and 35 microseconds. Turn power OFF. Remove +5V MAIN board and reinstall R57 and R58. Remove clip lead between logic common and collector of Q7.										



Table 5-3. Failure Location (Continued)

Step	Procedure
9 (cont)	If clip lead is not removed, +5V main regulator will have only the overcurrent limit as an overload protector during normal operation.
10	Turn OFF power supply and remove supply from computer. Disconnect power supply from ac source. Remove cover and disconnect fan. Reconnect power supply and turn power supply ON. If fuses do not blow, fan is shorted. Check fan wires. Replace fuses or fan if necessary.
11	Step 11 deleted.
12	With power supply turned off and disconnected from ac source, unplug P2 and P3 from RFO board. Remove two secondary fuses, A1F1 and A1F2, from the power supply chassis. P3 should then be taped to prevent shorting. Connect power supply to ac source and turn ac power ON. If primary fuses are blown, transformer is shorted. Replace fuses or transformer if necessary.
13	If +5V MAIN fails to come up when power supply, ac power, is turned ON or ac power is restored, check ac voltage. If ac voltage is lower than 103 Vac, memory may still be retained provided power supply is in standby mode (battery connected and switch ON). When ac voltage is corrected, power supply should sequence on.
14	Turn OFF power supply, ac power, and battery switch. Remove power supply from computer and disconnect from ac power source. Remove +5V MAIN board and place board on an extender. Place extender and card into +5V main slot. Reconnect power supply to ac source. Turn ON ac power and battery switch. Check +35V line (pin 79 or 80) on the +5V MAIN board. Line should be above +30 V.
15	Check voltages specified in step 8 of this procedure.
16	Confirm that ac detect circuit is working. Pin 55 or 56 (AC ON-) should go to logic zero and stay there as long as ac power is up.



Table 5-3. Failure Location (Continued)

Step	Procedure
17	Confirm that ON DELAY- stays at a logic zero for 500 milliseconds \pm 50 milliseconds after AC ON- goes low. ON DELAY- should then go to a logic one and stay there until ac power is turned OFF or lost. This signal may be measured at test point J1 on the +5V MAIN board.
18	Check U5A pin 3 on the +5V MAIN board and confirm that the 60 kHz clock is there (reference 16.7 microseconds nominal period).
19	Check Q5 base on +5V MAIN board. Base should be approximately +0.6 V until ON DELAY- goes to a logic one. Then the base of Q5 should go to less than +0.4 V, after ON DELAY- goes low.
20	If the +5V MAIN comes up part way and is shut down, it would appear that +5V main output is overloaded or +5V main regulator is faulty. Check the computer backplane and computer cards for shorts on the +5V main line. Next, check the +5V main output and output capacitor (C5 on RFO board) with power OFF for a short. Turn on the ac power and check voltages specified in step 8. Repair shorts or replace output capacitor if necessary.
21	Check the output of AR2 and AR3 (pin 6 of each) on the +5V MAIN board. Observe that neither output exceeds the reference ramped signal on the emitter of Q6 by more than a diode drop (\sim 0.6 V) when the +5 REF RAMP signal is ramping up.
22	Check to see if there is a 32-millivolt peak-to-peak triangular waveform on AR1 pin 2 of the +5V MAIN board. The signal should have a period of about 16.7 microseconds (ignore the fine spikes).
23	Check the output at AR1 pin 7 on the +5V MAIN board. The output should switch from a logic zero to a logic one at a frequency of 60 kHz while the +5 REF RAMP is ramping up. The duty cycle should be greater than zero.
24	Check U6C pin 9 and U6D pin 13 on the +5V MAIN board. There should be a 30 kHz square wave on each of these while the +5 REF RAMP is ramping up. These two signals should also be 180 degrees out of phase.



Table 5-3. Failure Location (Continued)

Step	Procedure						
	<div style="text-align: center; border: 1px dashed black; padding: 5px; width: fit-content; margin: 0 auto;"> CAUTION </div> <p>The points in Step 25 are at +35 V. Isolation is essential; otherwise, equipment may be damaged.</p>						
25	<p>Isolate the oscilloscope from line ground. Connect probe and ground lead across R37, then R38. The signal across both resistors should have a 0.6 V amplitude and frequency of 30 kHz while the +5 REF RAMP is ramping up. The duty cycle should be greater than zero, but less than fifty percent.</p>						
26	<p>Check pass transistors Q14, Q16, Q17 and Q18 for open or shorted circuits. Replace faulty transistors.</p>						
27	<p>If the +5V MAIN comes all the way up and then is shut off after approximately 8 to 18 milliseconds, an overload condition is indicated. On the computer backplane, check the +12V and +5V STBY outputs. These voltages are measured with respect to logic common (LC) and can be located as follows:</p> <table style="margin-left: auto; margin-right: auto;"> <tr> <td style="padding-right: 40px;">+12V</td> <td>Pins 3, 4, 5, and 6</td> </tr> <tr> <td>+5V STBY</td> <td>Pins 7, 8, 9, and 10</td> </tr> <tr> <td>LC</td> <td>Pins 1 and 2</td> </tr> </table>	+12V	Pins 3, 4, 5, and 6	+5V STBY	Pins 7, 8, 9, and 10	LC	Pins 1 and 2
+12V	Pins 3, 4, 5, and 6						
+5V STBY	Pins 7, 8, 9, and 10						
LC	Pins 1 and 2						
	<p>If the preceding voltages are all low ($\sim +1.5$ V), the standby crowbar has been fired. The BATTERY switch must be turned OFF to delatch the crowbar. The power supply should now sequence on when the power supply, ac power, and BATTERY switch are turned on, respectively.</p>						
28	<p>If any of the preceding voltages were low but not crowbarred, the input power should be turned OFF and the power supply should be disconnected from the ac power source. Turn the BATTERY switch OFF and remove the power supply from the computer backplane. Check the backpanel for a short on the regulator outputs. Place the MARR board on an extender and plug the extender into the power supply. Check the standby regulator outputs for shorts. Repair shorts if necessary.</p>						



Table 5-3. Failure Location (Continued)

Step	Procedure												
29	<p>Check the following voltages on the MARR board after ac power is turned ON. These voltages should be measured with respect to logic common.</p> <table data-bbox="617 462 1185 682"> <tr> <td>+21.5V AUX</td> <td>Pins 45 and 46</td> </tr> <tr> <td>+5V AUX</td> <td>Pins 43 and 44</td> </tr> <tr> <td>BAT+</td> <td>Pines 67 and 68</td> </tr> <tr> <td>-4.3V</td> <td>Anode of CR27</td> </tr> <tr> <td>+35V</td> <td>Pins 77 and 78</td> </tr> <tr> <td>+9V</td> <td>Pins 65 and 66</td> </tr> </table>	+21.5V AUX	Pins 45 and 46	+5V AUX	Pins 43 and 44	BAT+	Pines 67 and 68	-4.3V	Anode of CR27	+35V	Pins 77 and 78	+9V	Pins 65 and 66
+21.5V AUX	Pins 45 and 46												
+5V AUX	Pins 43 and 44												
BAT+	Pines 67 and 68												
-4.3V	Anode of CR27												
+35V	Pins 77 and 78												
+9V	Pins 65 and 66												
30	<p>Check the pass transistors of the bad regulator or regulators to see if the transistors are open or shorted. Replace transistors if necessary.</p>												
31	<p>Check the -5V output for an overload (pins 71 and 72).</p>												
32	<p>Check pins 61 and 62 of the MARR for -9V. The voltage should exceed -8.0 V.</p>												
33	<p>Check transistor Q45. Replace it if it is open or shorted.</p>												
34	<p>If the +5V MAIN comes up and stays up but the MRESET- signal is not generated, check the output of AR4 pin 6. The output should be 5 volts or lower after the ALL REG UP- line goes low (pin 53 or 54).</p>												
35	<p>Check Q19 for shorts.</p>												
36	<p>Check Q10 for shorts.</p>												
37	<p>The power supply does not sequence off properly when:</p> <ol data-bbox="487 1354 1445 1533" style="list-style-type: none"> The MRESET- signal is not generated. The POFF signal is not generated. REF ENABLE is not disabled, or is disabled before the POFF pulse or MRESET- is generated. 												
38	<p>If the +5V MAIN shuts down the same time as the turn-off sequence is initiated, the power supply has or has had an overload condition. The overload latch is set and can be reset only by turning ac power off and back on again.</p>												
39	<p>Check the ALL REG UP- line (pins 53 and 54) on the +5V board. This line should go to a logic zero when all the regulators are up and go to a one when the +5V MAIN or one of the other voltages go below a predetermined level. (See table 4-2.)</p>												



Table 5-3. Failure Location (Continued)

Step	Procedure																				
40	When ac power is lost, the output at U7C pin 6 on the +5V MAIN card should go to a logic zero. The collector of Q10 should rise to the +35V line. The output of AR4 (pin 7) should go high. MRESET- should go to a logic zero.																				
41	The REF ENBL- signal (base of Q5 on the +5V MAIN board) should go to +0.6 V when MRESET- goes low.																				
42	If the POFF pulse is not generated, check U3 on the +5V MAIN board. Pin 5 should remain at a logic one until after pins 3 and 4 go to a logic zero. Pin 6 should remain a zero until pins 3 and 4 go to zero. Pin 6 should then go to a one for approximately 1.2 milliseconds.																				
43	If the power supply sequences off with ac power ON, check for low line voltage. The line voltage should be above 103 Vac, 47 to 63 Hz.																				
44	If the line voltage is 103 Vac or greater, a thermal cutout may have occurred. Wait until the heatsink has had sufficient time to cool. Check the ambient temperature to see that specifications have not been exceeded.																				
45	Isolate the overvoltage. Check the respective SCR and drive circuit for failures. Check the following components for improper operation and replace if needed:																				
Component and Location																					
<u>Voltage</u>	<table border="1" style="width: 100%; border-collapse: collapse;"> <thead> <tr> <th style="width: 15%;"></th> <th style="width: 20%;">RFO</th> <th style="width: 20%;">+5 MAIN</th> <th style="width: 45%;">MARR</th> </tr> </thead> <tbody> <tr> <td>+5 MAIN</td> <td>SCR1</td> <td>Q13, Q21, CR12</td> <td>---</td> </tr> <tr> <td>+5 STBY</td> <td>-</td> <td>-</td> <td>Q30, Q31, Q37, Q39, CR30</td> </tr> <tr> <td>+12V MEM</td> <td>-</td> <td>-</td> <td>Q29, Q30, Q37, Q39, CR30</td> </tr> <tr> <td>-5V</td> <td>-</td> <td>-</td> <td>Q44, CR32, CR33</td> </tr> </tbody> </table>		RFO	+5 MAIN	MARR	+5 MAIN	SCR1	Q13, Q21, CR12	---	+5 STBY	-	-	Q30, Q31, Q37, Q39, CR30	+12V MEM	-	-	Q29, Q30, Q37, Q39, CR30	-5V	-	-	Q44, CR32, CR33
	RFO	+5 MAIN	MARR																		
+5 MAIN	SCR1	Q13, Q21, CR12	---																		
+5 STBY	-	-	Q30, Q31, Q37, Q39, CR30																		
+12V MEM	-	-	Q29, Q30, Q37, Q39, CR30																		
-5V	-	-	Q44, CR32, CR33																		
<p>If trouble is not located by resistive measurements, remove power supply from computer and turn the supply on. Use an external supply current limited to 100 milliamperes or less. Set the voltage of this supply to the test voltage. Observing the correct polarity on the supply, temporarily connect the supply to the output voltage under test. Slowly increase the external supply voltage until the power supply crowbars this output or the maximum overvoltage sensor level is exceeded. (See table 4-1.)</p>																					



Table 5-3. Failure Location (Continued)

Step	Procedure												
46	Check output capacitor C5 on the RFO board. If capacitor is loose or faulty, the +5V ripple limits may be exceeded. Replace capacitor if necessary.												
47	Check inductors L1 and L2 on the +5V board. If one or both of these are cracked, have shorted windings, or have an open circuit, the +5V MAIN will have excessive ripple. Replace inductors if necessary.												
48	Check commutating diodes CR8 and CR11 on the +5V MAIN board for proper operation.												
49	Check voltages as specified in Step 8.												
50	Check the triangular synchronizing signal as specified in Step 22.												
51	Check AR3 and AR2 outputs on +5V MAIN board. Observe that neither is more than a diode drop above the +5V REF; i. e., less than +5.6 V each.												
52	Check the output capacitor as specified in Step 46. Check inductors as specified in Step 47. Check commutating diodes as specified in Step 48.												
53	<p>If a regulator output is the incorrect value, a problem probably exists in the reference. All voltage references are developed on the MARR board. See the chart below for the output voltage and adjustment.</p> <table data-bbox="454 1268 1461 1604"> <thead> <tr> <th data-bbox="454 1310 1169 1352"><u>Voltage</u></th> <th data-bbox="1169 1268 1461 1352"><u>Adjustment Potentiometer</u></th> </tr> </thead> <tbody> <tr> <td data-bbox="454 1373 1169 1415">+5V MAIN (dependent on +5V REF)</td> <td data-bbox="1169 1373 1461 1415">R29</td> </tr> <tr> <td data-bbox="454 1415 1169 1457">-5V</td> <td data-bbox="1169 1415 1461 1457">-</td> </tr> <tr> <td data-bbox="454 1457 1169 1499">+5V STBY</td> <td data-bbox="1169 1457 1461 1499">R98</td> </tr> <tr> <td data-bbox="454 1499 1169 1541">+12V MEM</td> <td data-bbox="1169 1499 1461 1541">R99</td> </tr> <tr> <td data-bbox="454 1541 1169 1583">BAT. CHARGER</td> <td data-bbox="1169 1541 1461 1583">R92</td> </tr> </tbody> </table>	<u>Voltage</u>	<u>Adjustment Potentiometer</u>	+5V MAIN (dependent on +5V REF)	R29	-5V	-	+5V STBY	R98	+12V MEM	R99	BAT. CHARGER	R92
<u>Voltage</u>	<u>Adjustment Potentiometer</u>												
+5V MAIN (dependent on +5V REF)	R29												
-5V	-												
+5V STBY	R98												
+12V MEM	R99												
BAT. CHARGER	R92												
54	If the reference is adjusted properly and the output is the wrong value, the trouble lies in the respective regulator. A check should be made of the respective drive and pass transistors for the failed regulator.												



Table 5-3. Failure Location (Continued)

Step	Procedure
55	The battery charger output should be as listed in table 4-3. The output is adjusted by potentiometer R92 on the MARR board. The voltage should be carefully set to prevent battery damage.
56	If the battery charger fails to regulate, check diode CR3 on the MARR board. The voltage across this diode should be about 6.2 V. If this diode fails to isolate the problem, check the pass and drive transistors.
57	With ac power OFF, battery removed, and battery switch ON, check for a short between pin 1 of F3 on the power supply chassis and pin 5 of J1 on the chassis. If a short does exist, turn BATTERY switch OFF and repeat the preceding measurement to isolate the problem to either the battery charger output or the battery test switch and load resistor. Replace faulty components.
58	Check the battery for a failure (faulty cell or cells) while the battery switch is OFF. Check by measuring the voltage across each battery while the load switch is depressed for one minute. The voltage in either case should be greater than +11.5 V. Disconnect the battery and measure charger output on battery connector J1 pins 3(+) and 5(-) with ac power ON and BATTERY switch ON. The voltage should read 27.4 ± 0.6 . Depress the BATTERY TEST switch. The voltage should decrease to approximately 15 V. If the voltage does not decrease as specified, check the 25-ohm resistor R1 on the chassis. If R1 is not faulty, then the battery charger current limit has failed.

5.5 SIGNAL WAVEFORMS

The following waveforms illustrate critical points in the +5V MAIN switching regulator. These waveforms are shown with reference to the 60 kHz clock. All reference designations refer to the +5V MAIN regulator and control board unless specified otherwise.

Waveforms were measured with a Type 551 Tektronix Oscilloscope and a Type 1A1 Tektronix Plug-in Preamplifier. A similar configuration is recommended when attempting to duplicate these waveforms.

A list of pertinent information appears adjacent to each waveform. This information includes signal waveform nomenclature and/or location and correct oscilloscope control settings.



NOTE

Special test methods must be implemented when measuring output ripple. A normal ground lead on an oscilloscope probe will pick up stray noise that will appear to exceed the ripple specifications. Accurate measurements are made by use of an oscilloscope probe tip containing a grounding pin or with a length of coax modified for use as a probe.

a. Waveform 1 (figure 5-2)

Upper Trace: U5B, pin 11. Vertical sensitivity is 5 volts/cm.

Lower Trace: Cathode of CR8. Vertical sensitivity is 10 volts/cm.

Horizontal Sweep: 10 microseconds/cm

Trigger: Upper +

Test Conditions: No load on 5 volts/main

Reference Drawing: 943691

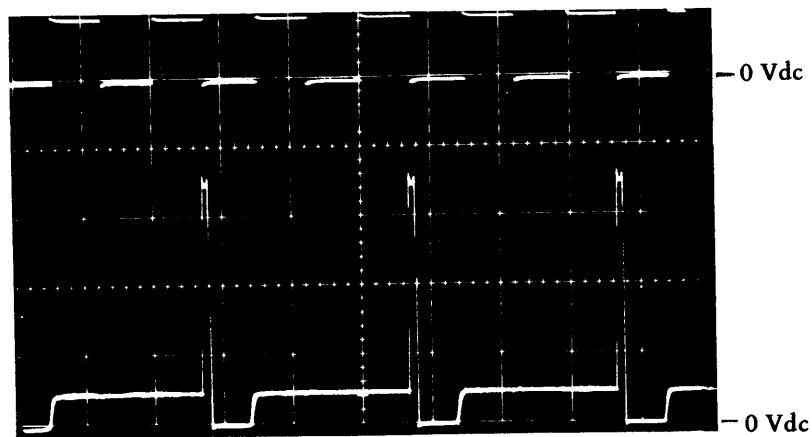

Figure 5-2. Waveform 1



b. Waveform 2 (figure 5-3)

Upper Trace: U5B, pin 11. Vertical sensitivity is 5 volts/cm.

Lower Trace: Cathode of CR8. Vertical sensitivity is 10 volts/cm.

Horizontal Sweep: 10 microseconds/cm

Trigger: Upper +

Test Conditions: 10 ampere load on 5 volt/main

Reference Drawing: 943691

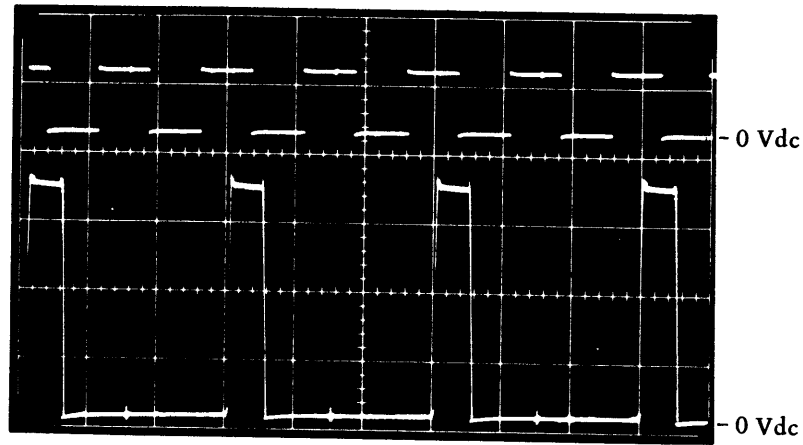

Figure 5-3. Waveform 2



c. Waveform 3 (figure 5-4)

Upper Trace: U5B, pin 11. Vertical sensitivity is 5 volts/cm.

Lower Trace: Cathode of CR8. Vertical sensitivity is 10 volts/cm.

Horizontal Sweep: 10 microseconds/cm

Trigger: Upper +

Test Conditions: 20 ampere load on 5 volt/main

Reference Drawing: 943691

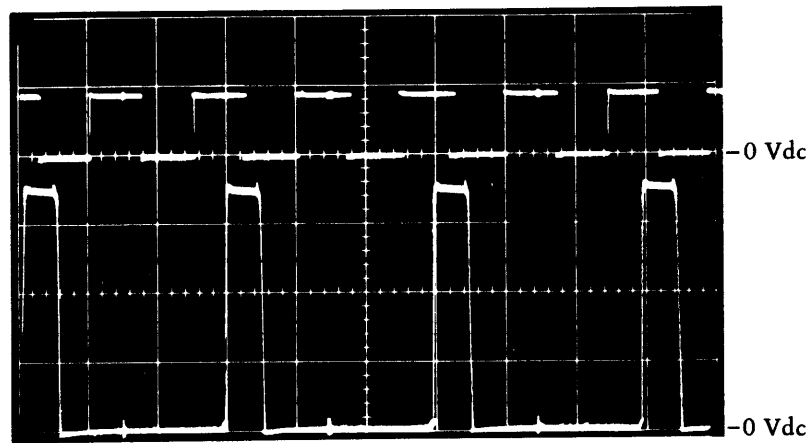

Figure 5-4. Waveform 3



d. Waveform 4 (figure 5-5)

Upper Trace: U5B, pin 11. Vertical sensitivity is 5 volts/cm.

Lower Trace: Cathode of CR8. Vertical sensitivity is
10 volts/cm.

Horizontal Sweep: 10 microseconds/cm

Trigger: Upper +

Test Conditions: 30 ampere load on 5 volt/main

Reference Drawing: 943691

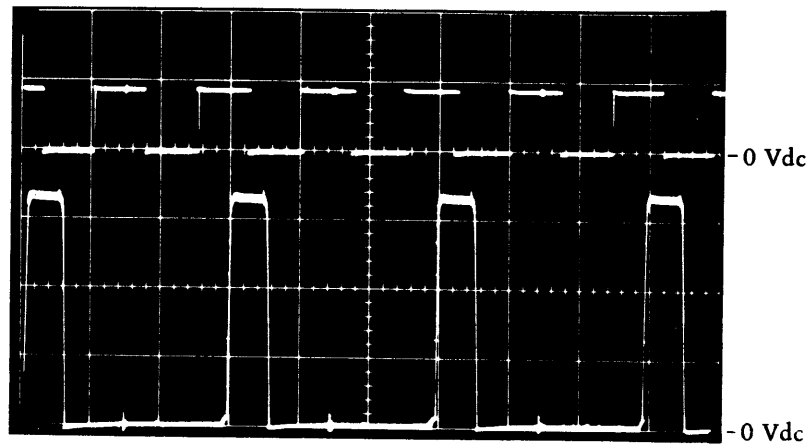

Figure 5-5. Waveform 4



e. Waveform 5 (figure 5-6)

Upper Trace: U5B, pin 11. Vertical sensitivity is 5 volts/cm.

Lower Trace: AR1, pin 2. Vertical sensitivity is 50 millivolts/cm ac coupled.

Horizontal Sweep: 5 microseconds/cm

Trigger: Upper +

Test Conditions: 30 ampere load on 5 volt/main

Reference Drawing: 943691

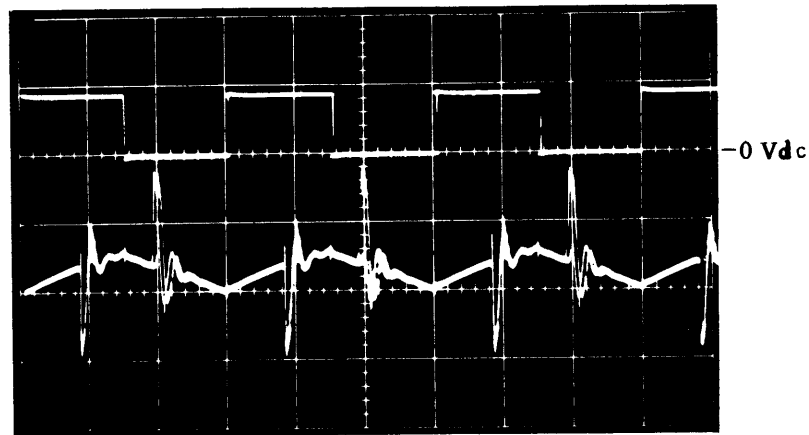

Figure 5-6. Waveform 5



f. Waveform 6 (figure 5-7)

Upper Trace: AR1, pin 2. Vertical sensitivity is 50 millivolts/cm ac coupled.

Lower Trace: AR1, pin 7. Vertical sensitivity is 2 volts/cm.

Horizontal Sweep: 5 microseconds/cm

Trigger: Lower +

Test Conditions: 30 ampere load on 5 volt/main

Reference Drawing: 943691

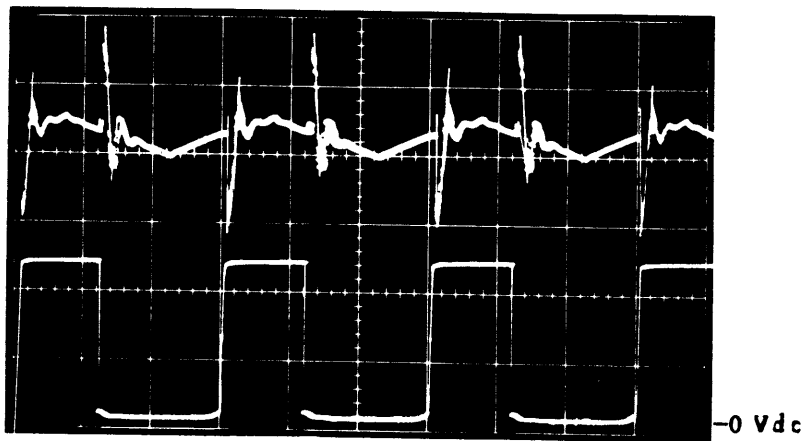

Figure 5-7. Waveform 6



i. Waveform 9 (figure 5-10)

Upper Trace: XA2, pin 7. Vertical sensitivity is 50 millivolts/
cm ac coupled.

Horizontal Sweep: 10 microseconds/cm

Trigger: Upper +

Test Conditions: 30 ampere load on 5 volt/main

Reference Drawing: 943691

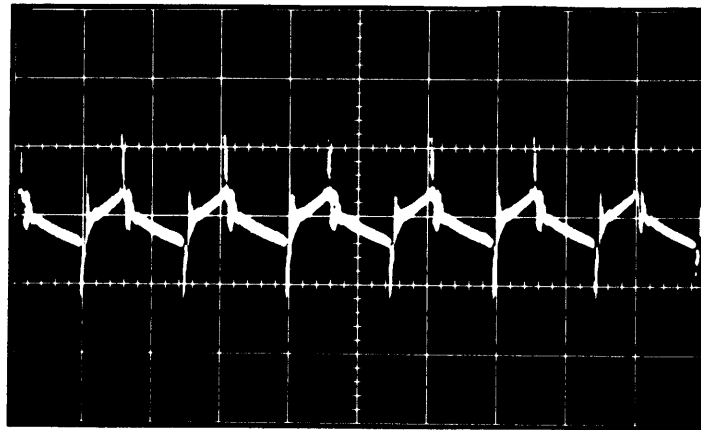

Figure 5-10. Waveform 9



j. Waveform 10 (figure 5-11)

Upper Trace: XA2, pins 57 and 58. Vertical sensitivity is 10 volts/cm.

Horizontal Sweep: 2 milliseconds/cm

Trigger: Line +

Test Conditions: 30 ampere load on 5 volt/main

Reference Drawing: 943691

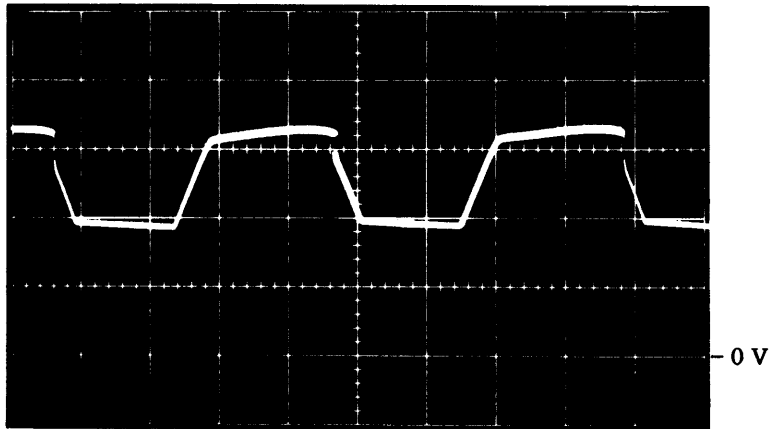

Figure 5-11. Waveform 10



SECTION VI
DRAWINGS

This section contains the electrical and assembly drawings required to properly service and maintain the power supply. The drawings included in this section are listed below with their titles and the page numbers on which they begin.

<u>Description</u>	<u>Drawing No.</u>	<u>Page No.</u>
Power Supply - LM Assembly Drawing	943679	6-3 6-19
Wire List, Power Supply, 960B/980B	943681	6-23
Power Supply Chassis Assembly, Schematic Diagram	943684	6-27
Rectifier, Filter and Output Card - LM Assembly Drawing	943685	6-31 6-39
+5 Volt Main Regulator and Control Card - LM Assembly Drawing	943689	6-43 6-53
+5 Volt Main Regulator and Control, Schematic Diagram	943691	6-57
Memory, Auxiliary, and Reference Regulator - LM Assembly Drawing	943692	6-61 6-77
Memory, Auxiliary, and Reference Regulator, Schematic Diagram	943695	6-81

Change 1

6-3

Digital Systems Division



TEXAS INSTRUMENTS
INCORPORATED

DATE 09/21/77

LIST OF MATERIAL

PAGE 1 of

PART NUMBER	REV
LM0943675-0001	U

PRINT ITEM NUMBER	QUANTITY PER ASSEMBLY	UNIT OF ISSUE	DWG. SIZE	PART NUMBER	DESCRIPTION	VENDOR PART NUMBER	
0001	0001.000	EA		0960731-0004	HOUSING, CPU-POWER SUPPLY		
0002	0001.000	EA		0226720-0001	PANEL, COVER 01+00+05		
0003	0001.000	EA		0226736-0001	ROD, ALIGNING 01+00+03		
0004	0001.000	EA		0943753-0001	COVER		
0005	0001.000	EA		0973572-0001	TRANSFORMER, A.C. PWR 115V/230V-100V/200V		
0006	0001.000	EA		0943685-0001	CARD ASSY, RECTIFIER, FILTER AND OUTPUT		
0006A					A1		
0007	0001.000	EA		0943689-0001	CARD ASSY, PWB, +5V MAIN REG & CONTRL		
0007A					A2		
0008	0001.000	EA		0943692-0001	CARD ASSY, MEM AUX & REF REG		
0008A					A3		
0009	0001.000	EA		0539760-0002	SWITCH, DPST 15A 125/250V .25 QIK CGNN	MIC -12TS95-2	
0009A					S3		
0010	0001.000	EA		0975270-0005	TERMINAL BLOCK 5 POSITION PUSH-ON TERMS.		
0010A					TB1		
0011	0001.000	EA		0973621-0001	DECAL, 115 VOLTS 10 AMPS		
0013	0003.000	EA		0232092-0003	HOLDER FUSE MKP-HH	BUS -FKP-HH	
0014	0001.000	EA		0416434-0203	FUSE 2.0 A 250V 3AG	LIT - 312002	
0014A					F3		
0015	0001.000	EA		0088035-0005	CORD-GROUND PRNG PLUG POWER SERVICE	BEL - 17407	
DRAFTSMAN		DATE	CKD. DRAFTSMAN	DATE	DESIGN ENGINEER	DATE	TITLE
			<i>A.R. Perry</i>	9-23-77			POWER SUPPLY ASSY-CPU, 115V
APPD. MFG		DATE	APPD. PROJECT ENGINEER	DATE	RELEASED	DATE	PROJECT NO.
							7500
						PART NUMBER	REV
						LM0943675-0001	U

T.I. 13849



942773-9703



TEXAS INSTRUMENTS
INCORPORATED

DATE 09/21/77

LIST OF MATERIAL

PAGE 2 of

PART NUMBER	REV
LM0943679-0001	U

PRINT ITEM NUMBER	QUANTITY PER ASSEMBLY	UNIT OF ISSUE	DWG. SIZE	PART NUMBER	DESCRIPTION	VENDOR PART NUMBER	
0016	00001.000	EA		0235590-0075	SWITCH PB SPST (N.O.) 1 AMP 125V POS. FEEL	GRY -30-17R (N.O.)	
0016A					S2		
0017	00001.000	EA		0539760-0001	SWITCH SPST 15A 125-250 VAC .250	MIC -11TS95-2	
0017A					S1		
0018	00001.000	EA		0231253-0083	CONNECTOR 6P WHT PLUG 480083-1	AMP -480083	
0018A					J1		
0019	00001.000	EA		0231253-0084	CONNECTOR 6P WHT CAP 480084-1	AMP -480084-1	
0019A					P2		
0020	00008.000	EA		0232142-0003	CONTACT #18-#22 WIRE	AMP -42859-1	
0021	00015.000	EA		0235833-0211	TERMINAL RECP PRE-INS BLUE TIN PLTD BRAS	AMP -42332-4 TAPE F	
0022	00005.000	EA		0235837-0045	TERMINAL RCPT FASTON 22-18 TIN PLD BRASS	AMP -42599-4 TAPE F	
0023	00001.000	EA		0539361-0001	RES 25.00 OHM 25W 5%	DHM -TYPE 020GC	
0023A					R1		
0024	00001.000	EA		0232036-1000	HANDLE AL 1/4 OD 3"CTR SATIN FINISH	SMI -1622	
0026	REF	EA		0943684-9901	DIAG, SCHEMATIC, CHASSIS ASSY-CPU		
0027	REF	EA		0943682-9901	TEST PROCEDURE, POWER SUPPLY		
0028	REF	EA		0943681-9901	WIRE LIST, POWER SUPPLY		
0029	00001.000	EA		0226798-0001	FAN, AXIAL		
0029A					B1		
0031	00001.000	EA		0172410-0001	NAMEPLATE-PART/SERIAL NO		
DRAFTSMAN		DATE	CKD. DRAFTSMAN	DATE	DESIGN ENGINEER	DATE	TITLE
APPD.-MFG.		DATE	APPD. PROJECT ENGINEER	DATE	RELEASED	DATE	PROJECT NO.
						PART NUMBER	REV
						LM0943679-0001	U

T.I. 13849

Change 1

6-4

Digital Systems Division

942773-9703



TEXAS INSTRUMENTS
INCORPORATED

DATE 09/21/77

LIST OF MATERIAL

PAGE 3 of

PART NUMBER	REV
LM0943679-0001	U

PRINT ITEM NUMBER	QUANTITY PER ASSEMBLY	UNIT OF ISSUE	DWG. SIZE	PART NUMBER	DESCRIPTION	VENDOR PART NUMBER	
0032	0000.750	FT		0411634-2600	SLEEVE,PVC .263 DIA .020 WALL	QPL - MIL-I-631D	
0033	00001.000	EA		0083714-0003	GROMMET 1/4 I.D. 1042	WAL - 7034	
0034	00003.000	EA		0231103-0000	CLAMP 2C1-150	DAK - 2C1-150	
0035	00001.000	EA		0454990-0025	BUSHING,STR RLF-.325-.36 WIRE .625 DIA		
0036	00001.000	EA		0972838-0005	FILTER,AC		
0036A					FL1		
0037	00002.000	EA		0972988-0013	SCREW 4-40 X .250 PAN HEAD CRES		
0038	00001.000	EA		0972988-0030	SCREW 6-32 X .500 PAN HEAD CRES		
0039	00010.000	EA		0972988-0027	SCREW 6-32 X .312 PAN HEAD CRES		
0041	00006.000	EA		0972988-0026	SCREW 6-32 X .250 PAN HEAD CRES		
0042	00002.000	EA		0972990-0023	SCREW 6-32 X .250 FLT HEAD CRES		
0043	00002.000	EA		0972988-0045	SCREW 8-32 X .500 PAN HEAD CRES		
0045	00003.000	EA		0972992-0011	SCREW 10-32 .500 FLT HEAD CRES		
0046	00004.000	EA		0416622-0013	WASHER #6 FLAT	QPL - AN960C6L	
0047	00002.000	EA		0411101-0057	LOCKWASHER # 4 EXTERNAL TOOTH CRES	QPL - MS35335-57	
0048	00020.000	EA		0411101-0058	LOCKWASHER #6 EXTERNAL TOOTH CRES	QPL - MS35335-58	
0049	00004.000	EA		0539708-0003	NUT 10-32X1/2 LOCK CAD PLT STL	MGN - 22SFAU-1032	
0051	00002.000	EA		0411115-0044	NUT,4-40 HEXAGON CRES STEEL	MS - 35649-244	
0052	00006.000	EA		0416453-0022	NUT,PLAIN 6-32 UNC-2B HEX CRES,SMALL	QPL - NAS671C6	
0053	00001.000	EA		0416453-0024	NUT,#10 HEX SMALL PATTERN		
DRAFTSMAN		DATE	CKD. DRAFTSMAN	DATE	DESIGN ENGINEER	DATE	TITLE
							POWER SUPPLY ASSY-CPU, 115V
APPD. MFG		DATE	APPD. PROJECT ENGINEER	DATE	RELEASED	DATE	PROJECT NO.
						PART NUMBER	REV
						LM0943679-0001	U

T.I. 13849

Change 1

6-5

Digital Systems Division

942773-9703

Change 1

6-6

Digital Systems Division



TEXAS INSTRUMENTS
INCORPORATED

DATE 09/21/77

LIST OF MATERIAL

PAGE 4 of

PART NUMBER	REV
LM0943679-0001	U

PRINT ITEM NUMBER	QUANTITY PER ASSEMBLY	UNIT OF ISSUE	DWG. SIZE	PART NUMBER	DESCRIPTION	VENDOR PART NUMBER	
0054	AR	EA		0235182-0002	LOCTITE SEALANT GRADE 242	LJC --242	
0055	00002.000	EA		0411104-0137	WASHER #8 LOCKSPLIT	QPL - MS35338-137	
0056	00001.000	EA		0772995-0004	FUSE 10 AMP SLOW BLOW 1/4X1-1/4 IN	BUS -MDA10.0	
0056A					F5		
0058	00004.400	FT		0538347-4099	WIRE HOOKUP B-20 AWG 19 STR BK/WH	JUD - HH0118	
0059	00004.900	FT		0538347-4299	WIRE HOOKUP B-20 AWG 19 STR RD/WH	JUD - HH0118	
0060	00001.600	FT		0538347-4399	WIRE HOOKUP B-20 AWG 19 STR OR/WH	JUD - HH0118	
0061	00002.300	FT		0538347-4499	WIRE HOOKUP B-20 AWG 19 STR YL/WH	JUD - HH0118	
0062	00002.000	FT		0417682-9099	WIRE HOOKUP 16 AWG TYPE B INS BK/WH	JUD - HH0205	
0064	00001.300	FT		0417682-9999	WIRE HOOKUP 16 AWG TYPE B INS WHITE	JUD - HH0205	
0065	00004.000	EA		0232143-3000	INSERT CONN PLASTIC POLARIZING	ELC -60-6300-42-18	
0067	00001.000	EA		0232354-0003	LUG #10 RING TONGUE VINYL INS AWG 22-16	AMP -31884	
0067A					E4		
0069	00001.000	EA		0416622-0033	WASHER #10 FLAT	QPL - AN560C10L	
0070	00001.000	EA		0411101-0060	LOCKWASHER #10 EXTERNAL TOOTH CRES	---	
0071	00004.200	FT		0417682-0599	WIRE HOOKUP 14 AWG TYPE B INS GN/WH	JUD - HH1201	
0072	00001.000	EA		0054186-0014	FUSE 15 A 125V 3AB ANTI VIBRATION	LIT - 314015	
0072A					F1		
0074	00003.000	EA		0410894-0044	LOCKWASHER 7/16 INTERNAL TOOTH CRES	SHA - 1722-01	
0076	00004.000	EA		0158532-0006	SPACER- 9/16 LG TAPPED 6-32		
DRAFTSMAN		DATE	CKD. DRAFTSMAN	DATE	DESIGN ENGINEER	DATE	TITLE
APPD. MFG.		DATE	APPD. PROJECT ENGINEER	DATE	RELEASED	DATE	PROJECT NO.
						POWER SUPPLY ASSY-CPU, 115V	
						PART NUMBER	REV
						LM0943679-0001	U

T.I. 13849



942773-9703

Change 1

6-7

Digital Systems Division



TEXAS INSTRUMENTS
INCORPORATED

DATE 09/21/77

LIST OF MATERIAL

PAGE 5 of

PART NUMBER	REV
LM0943679-0001	U

PRINT ITEM NUMBER	QUANTITY PER ASSEMBLY	UNIT OF ISSUE	DWG. SIZE	PART NUMBER	DESCRIPTION	VENDOR PART NUMBER	
0077	00001.000	EA		0966576-0001	LABEL, CAUTION-PRINTED ADHESIVE		
0079	00001.000	EA		0418212-0040	STRAP, TIEDOWN, ADJUSTABLE, PLASTIC	QPL - MS3367-4-9	
0081	00002.000	EA		0410958-0003	PLUG, PROTECTIVE, DUST	GCN - H310-F	
0082	00001.000	EA		0972990-0028	SCREW 6-32 X .625 FLT HEAD CRES		
0085	00001.000	EA		0943863-9701	MANUAL, MAINT VOL V-960B/980B		
0086	00001.000	EA		0943750-0001	FILTER ELEMENT		
0087	00002.000	EA		0418170-0012	SCREW, SELF TAP, 4-40X3/8		
0088	00002.000	EA		0235837-1000	TERMINAL LUG FASTEN INSUL AWG 22-18	AMP - 60572-3 TAPE M	
0089	AR	FT		0417177-0179	SLEEVE, PVC .187 DIA BLACK .025 WALL	QPL - MIL-1-23053/2	
0090	00001.000	EA		0943764-0001	BOX FILTER		
0091	00002.000	EA		0972990-0016	SCREW 4-40 X .500 FLT HEAD CRES		
0092	00004.000	EA		0943822-0001	WASHER, FLAT		
DRAFTSMAN		DATE	CKD. DRAFTSMAN	DATE	DESIGN ENGINEER	DATE	TITLE
							POWER SUPPLY ASSY-CPU, 115V
APPD. MFG.		DATE	APPD. PROJECT ENGINEER	DATE	RELEASED	DATE	PROJECT NO.
						PART NUMBER	REV
						LM0943679-0001	U



942773-9703



TEXAS INSTRUMENTS
INCORPORATED

DATE 09/21/77

LIST OF MATERIAL

PAGE 1 of

PART NUMBER	REV
LM0943675-0002	U

PRINT ITEM NUMBER	QUANTITY PER ASSEMBLY	UNIT OF ISSUE	DWG. SIZE	PART NUMBER	DESCRIPTION	VENDOR PART NUMBER
0001	00001.000	EA		0943679-0001	POWER SUPPLY ASSY-CPU, 115V	
0002	00001.000	EA		0943733-0003	KIT, 960B/980B P/S VOLTAGE CONVERSION	

DRAFTSMAN	DATE	CKD. DRAFTSMAN	DATE	DESIGN ENGINEER	DATE	TITLE
						POWER SUPPLY ASSY-CPU, 100V
APPD. MFG.	DATE	APPD. PROJECT ENGINEER	DATE	RELEASED	DATE	PROJECT NO.

PART NUMBER	REV
LM0943675-0002	U

T.I. 13849

Change 1

6-8

Digital Systems Division

942773-9703

Change 1

6-9

Digital Systems Division



TEXAS INSTRUMENTS
INCORPORATED

DATE 09/21/77

LIST OF MATERIAL

PAGE 1 of

PART NUMBER REV
LM0943679-0003 U

PRINT ITEM NUMBER	QUANTITY PER ASSEMBLY	UNIT OF ISSUE	DWG. SIZE	PART NUMBER	DESCRIPTION	VENDOR PART NUMBER
0001	00001.000	EA		0943679-0001	POWER SUPPLY ASSY-CPU, 115V	
0002	00001.000	EA		0943733-0001	KIT, 960B/980B P/S VOLTAGE CONVERSION	

DRAFTSMAN	DATE	CKD. DRAFTSMAN	DATE	DESIGN ENGINEER	DATE	TITLE
						POWER SUPPLY ASSY-CPU, 230V
APPD.-MFG	DATE	APPD. PROJECT ENGINEER	DATE	RELEASED	DATE	PROJECT NO.

	PART NUMBER	REV
	LM0943679-0003	U

T.I. 13849



942773-9703



TEXAS INSTRUMENTS
INCORPORATED

DATE 09/21/77

LIST OF MATERIAL

PAGE 1 of

PART NUMBER	REV
LM943679-0004	U

PRINT ITEM NUMBER	QUANTITY PER ASSEMBLY	UNIT OF ISSUE	DWG. SIZE	PART NUMBER	DESCRIPTION	VENDOR PART NUMBER
0001	00001.000	EA		0943679-0001	POWER SUPPLY ASSY-CPU, 115V	
0002	00001.000	EA		0943733-0002	KIT, 960B/980B P/S VOLTAGE CONVERSION	

DRAFTSMAN	DATE	CKD. DRAFTSMAN	DATE	DESIGN ENGINEER	DATE	TITLE
						POWER SUPPLY ASSY-CPU, 200V
APPD. MFG	DATE	APPD. PROJECT ENGINEER	DATE	RELEASED	DATE	PROJECT NO.

PART NUMBER	REV
LM943679-0004	U

TI 13849

Change 1

6-10

Digital Systems Division

942773-9703

Change 1

6-11

Digital Systems Division



TEXAS INSTRUMENTS
INCORPORATED

DATE 09/21/77

LIST OF MATERIAL

PAGE 1 of

PART NUMBER	REV
LM943679-0005	L

PRINT ITEM NUMBER	QUANTITY PER ASSEMBLY	UNIT OF ISSUE	DWG. SIZE	PART NUMBER	DESCRIPTION	VENDOR PART NUMBER	
0001	00001.000	EA		0960731-0002	HOUSING, I/O EXPANDER		
0002	00001.000	EA		0226720-0001	PANEL, COVER 01+00+05		
0003	00001.000	EA		0226736-0001	ROD, ALIGNING 01+00+03		
0004	00001.000	EA		0943753-0001	COVER		
0005	00001.000	EA		0973572-0001	TRANSFORMER, A.C. PWR 115V/230V-100V/200V		
0005A					T1		
0006	00001.000	EA		0943685-0001	CARD ASSY, RECTIFIER, FILTER AND OUTPUT		
0006A					A1		
0007	00001.000	EA		0943689-0001	CARD ASSY, PWB, +5V MAIN REG & CONTROL		
0007A					A2		
0008	00001.000	EA		0943692-0002	CARD ASSY, MEM AUX & REF REG		
0008A					A3		
0009	00001.000	EA		0539760-0002	SWITCH, DPST 15A 125/250V .25 QIK CONN	MIC -12TS95-2	
0009A					S3		
0010	00001.000	EA		0975270-0005	TERMINAL BLOCK 5 POSITION PUSH-ON TERMS.		
0010A					TB1		
0011	00001.000	EA		0973621-0001	DECAL, 115 VOLTS 10 AMPS		
0013	00002.000	EA		0232052-0003	HOLDER FUSE MKP-MH	BUS -MKP-MH	
0015	00001.000	EA		0088035-0005	CORD-GROUND PRONG PLUG POWER SERVICE	BEL - 17407	
0019	00001.000	EA		0231253-0084	CONNECTOR 6P WHT CAP 480084-1	AMP -480084-1	
DRAFTSMAN		DATE	CKD. DRAFTSMAN	DATE	DESIGN ENGINEER	DATE	TITLE
							POWER SUPPLY ASSY - I/O, 115V
APPD. MFG.		DATE	APPD. PROJECT ENGINEER	DATE	RELEASED	DATE	PROJECT NO.
						PART NUMBER	REV
						LM943679-0005	U



942773-9703



TEXAS INSTRUMENTS
INCORPORATED

DATE 09/21/77

LIST OF MATERIAL

PAGE 2 of

PART NUMBER	REV
LM0943675-0005	U

PRINT ITEM NUMBER	QUANTITY PER ASSEMBLY	UNIT OF ISSUE	DWG. SIZE	PART NUMBER	DESCRIPTION	VENDOR PART NUMBER	
0019A					P2		
0020	00004.000	EA		0232142-0003	CONTACT #18-#22 WIRE	AMP -42859-1	
0021	00014.000	EA		0235833-0211	TERMINAL RECP PRE-INS BLUE TIN PLTD BRAS	AMP -42332-4 TAPE F	
0022	00005.000	EA		0235837-0045	TERMINAL RCPT FASTON 22-18 TIN PLD BRASS	AMP -42599-4 TAPE F	
0024	00001.000	EA		0232036-1000	HANDLE AL 1/4 OD 3"CTR SATIN FINISH	SMI -1622	
0026	REF	EA		0943684-9901	DIAG, SCHEMATIC, CHASSIS ASSY-CPU		
0027	REF	EA		0943682-9901	TEST PROCEDURE, POWER SUPPLY		
0028	REF	EA		0943734-9901	WIRE LIST, POWER SUPPLY, I/O ASSEMBLY		
0029	00001.000	EA		0226798-0001	FAN, AXIAL		
0029A					B1		
0031	00001.000	EA		0172410-0001	NAMEPLATE-PART/SERIAL NO		
0032	00000.750	FT		0411634-2600	SLEEVE, PVC .263 DIA .020 WALL	GPL - MIL-I-6510	
0033	00001.000	EA		0083714-0003	GROMMET 1/4 I.D. 1042	WAL - 7034	
0034	00003.000	EA		0231101-0000	CLAMP 2C1-75	DAK -2C1-75	
0035	00001.000	EA		0230211-0007	BUSHING STRT-THRU .325/.360 .125CHAS THK	MEY -SK-6P3-4	
0036	00001.000	EA		0972838-0005	FILTER, AC		
0036A					FL1		
0038	00001.000	EA		0972988-0030	SCREW 6-32 X .500 PAN HEAD CRES		
0039	00010.000	EA		0972988-0027	SCREW 6-32 X .312 PAN HEAD CRES		
0041	00006.000	EA		0972988-0026	SCREW 6-32 X .250 PAN HEAD CRES		
DRAFTSMAN		DATE	CKD. DRAFTSMAN	DATE	DESIGN ENGINEER	DATE	TITLE
APPD. MFG		DATE	APPD. PROJECT ENGINEER	DATE	RELEASED	DATE	PROJECT NO.
							POWER SUPPLY ASSY - I/O, 115V
						PART NUMBER	REV
						LM0943675-0005	U

T.I. 13849

Change 1

6-12

Digital Systems Division

942773-9703

Change 1

6-13

Digital Systems Division



TEXAS INSTRUMENTS
INCORPORATED

DATE 09/21/77

LIST OF MATERIAL

PAGE 3 of

PART NUMBER
LM0943679-0005 REV
U

PRINT ITEM NUMBER	QUANTITY PER ASSEMBLY	UNIT OF ISSUE	DWG. SIZE	PART NUMBER	DESCRIPTION	VENDOR PART NUMBER	
0042	00002.000	EA		0972990-0023	SCREW 6-32 X .250 FLT HEAD CRES		
0043	00002.000	EA		0972988-0045	SCREW 8-32 X .500 PAN HEAD CRES		
0046	00004.000	EA		0416622-0013	WASHER #6 FLAT	GPL - AN960C6L	
0047	00002.000	EA		0411101-0057	LOCKWASHER # 4 EXTERNAL TOOTH CRES	QPL - MS35335-57	
0048	00020.000	EA		0411101-0058	LOCKWASHER #6 EXTERNAL TOOTH CRES	QPL - MS35335-58	
0049	00003.000	EA		0539708-0003	NUT 10-32X1/2 LOCK CAD PLT STL	MGN -22SFAU-1032	
0052	00006.000	EA		0416453-0022	NUT,PLAIN 6-32 UNC-28 HEX CRES,SMALL	GPL - NAS67106	
0053	00001.000	EA		0416453-0024	NUT,#10 HEX SMALL PATTERN		
0054	AR	EA		0235182-0002	LOCTITE SEALENT GRADE 242	LOC --242	
0055	00002.000	EA		0411104-0137	WASHER #8 LOCKSPLIT	QPL - MS35338-137	
0056	00001.000	EA		0772995-0004	FUSE 10 AMP SLOW BLOW 1/4X1-1/4 IN	BUS -MCA10.0	
0056A					F4		
0058	AR	FT		0538347-4099	WIRE HOOKUP B-20 AWG 19 STR BK/WH	JUD - HH0118	
0062	00002.000	FT		0417682-9099	WIRE HOOKUP 16 AWG TYPE B INS BK/WH	JUD - HF0205	
0064	00001.300	FT		0417682-9999	WIRE HOOKUP 16 AWG TYPE B INS WHITE	JUD - HH0205	
0065	00004.000	EA		0232143-3000	INSERT CONN PLASTIC POLARIZING	ELL -60-6300-42-18	
0067	00001.000	EA		0232354-0003	LUG #10 RING TONGUE VINYL INS AWG 22-16	AMP -31884	
0067A					E4		
0069	00001.000	EA		0416622-0033	WASHER #10 FLAT	QPL - AN960C10L	
0070	00001.000	EA		0411101-0060	LOCKWASHER #10 EXTERNAL TOOTH CRES	---	
DRAFTSMAN		DATE	CKD. DRAFTSMAN	DATE	DESIGN ENGINEER	DATE	TITLE
APPD.-MFG		DATE	APPD. PROJECT ENGINEER	DATE	RELEASED	DATE	PROJECT NO.
						POWER SUPPLY ASSY - 1/0,115V	
						PART NUMBER	REV
						LM0943679-0005	U

T.I. 13849



942773-9703



TEXAS INSTRUMENTS
INCORPORATED

DATE 09/21/77

LIST OF MATERIAL

PAGE 4 of

PART NUMBER	REV
LM0943675-0005	U

PRINT ITEM NUMBER	QUANTITY PER ASSEMBLY	UNIT OF ISSUE	DWG. SIZE	PART NUMBER	DESCRIPTION	VENDOR PART NUMBER	
0071	00004.200	FT		0417682-0599	WIRE HOOKUP 14 AWG TYPE B INS GN/WH	JUD - HM1201	
0072	00001.000	EA		0054186-0014	FUSE 15 A 125V 3AB ANTI VIBRATION	LIT - 314015	
0072A					F1		
0074	00001.000	EA		0410894-0044	LOCKWASHER 7/16 INTERNAL TOOTH CRES	SHA - 1722-01	
0076	00004.000	EA		0158532-0006	SPACER- 9/16 LG TAPPED 6-32		
0077	00001.000	EA		0966576-0001	LABEL, CAUTION-PRINTED ADHESIVE		
0080	00001.000	EA		0966674-0001	PLATE, AIR FLOW RESTRICTION		
0081	00003.000	EA		0410958-0003	PLUG, PROTECTIVE, DUST	GCN --H310-F	
0082	00001.000	EA		0972990-0028	SCREW 6-32 X .625 FLT HEAD CRES		
0085	REF	EA		0943863-9701	MANUAL, MAINT VCL V-9608/9808		
0086	00001.000	EA		0943750-0001	FILTER ELEMENT		
0087	00002.000	EA		0418170-0012	SCREW, SELF TAP, 4-40X3/8		
0088	00002.000	EA		0235837-1000	TERMINAL LUG FASTGN INSUL AWG 22-18	AMP -60972-3 TAPE M	
0089	AR	FT		0417177-0179	SLEEVE, PVC .187 DIA BLACK .025 WALL	GPL - MIL-1-23053/2	
0090	00001.000	EA		0943764-0001	BOX FILTER		
0091	00005.000	EA		0972990-0016	SCREW 4-40 X .500 FLT HEAD CRES		
0092	00004.000	EA		0943822-0001	WASHER, FLAT		
DRAFTSMAN		DATE	CKD. DRAFTSMAN	DATE	DESIGN ENGINEER	DATE	TITLE
APPD. MFG.		DATE	APPD. PROJECT ENGINEER	DATE	RELEASED	DATE	PROJECT NO.
							PART NUMBER
							LM0943675-0005
							REV
							U

T.I. 13849

Change 1

6-14

Digital Systems Division

942773-9703

Change 1

6-15

Digital Systems Division



TEXAS INSTRUMENTS
INCORPORATED

DATE 09/21/77

LIST OF MATERIAL

PAGE 1 of

PART NUMBER	REV
LM0943679-0006	U

PRINT ITEM NUMBER	QUANTITY PER ASSEMBLY	UNIT OF ISSUE	DWG. SIZE	PART NUMBER	DESCRIPTION	VENDOR PART NUMBER
0001	0001.000	EA		0943679-0005	POWER SUPPLY ASSY - I/O, 115V	
0002	C0001.000	EA		0943733-0001	KIT, 960B/980B P/S VOLTAGE CONVERSION	

DRAFTSMAN	DATE	CKD. DRAFTSMAN	DATE	DESIGN ENGINEER	DATE	TITLE
						POWER SUPPLY, I/O, 230V
APPD.-MFG	DATE	APPD. PROJECT ENGINEER	DATE	RELEASED	DATE	PROJECT NO.

PART NUMBER	REV
LM0943679-0006	U



942773-9703



942773-9703



TEXAS INSTRUMENTS
INCORPORATED

DATE 09/21/77

LIST OF MATERIAL

PAGE 1 of

PART NUMBER	REV
LM0943679-0007	U

PRINT ITEM NUMBER	QUANTITY PER ASSEMBLY	UNIT OF ISSUE	DWG. SIZE	PART NUMBER	DESCRIPTION	VENDOR PART NUMBER
0001	00001.000	EA		0943679-0005	POWER SUPPLY ASSY - I/O, 115V	
0002	00001.000	EA		0943733-0J02	KIT, 9608/9808 P/S VOLTAGE CONVERSION	

DRAFTSMAN	DATE	CKD. DRAFTSMAN	DATE	DESIGN ENGINEER	DATE	TITLE
						POWER SUPPLY, I/O, 200V
APPD. MFG.	DATE	APPD. PROJECT ENGINEER	DATE	RELEASED	DATE	PROJECT NO.

PART NUMBER	REV
LM0943679-0007	U

T.I. 13849

Change 1

6-16

Digital Systems Division

Change 1

6-17/6-18

Digital Systems Division



TEXAS INSTRUMENTS
INCORPORATED

DATE 09/21/77

LIST OF MATERIAL

PAGE 1 of

PART NUMBER	REV
LM0943675-0008	U

PRINT ITEM NUMBER	QUANTITY PER ASSEMBLY	UNIT OF ISSUE	DWG. SIZE	PART NUMBER	DESCRIPTION	VENDOR PART NUMBER
0001	00001.000	EA		0943679-0005	POWER SUPPLY ASSY - I/C,115V	
0002	00001.000	EA		0943733-0003	KIT, 9608/9808 P/S VOLTAGE CONVERSION	

DRAFTSMAN	DATE	CKD. DRAFTSMAN	DATE	DESIGN ENGINEER	DATE	TITLE
						POWER SUPPLY, I/O,100V
APPD. MFG	DATE	APPD. PROJECT ENGINEER	DATE	RELEASED	DATE	PROJECT NO.

PART NUMBER	REV
LM0943675-0008	U

T.I. 13849



942773-9703

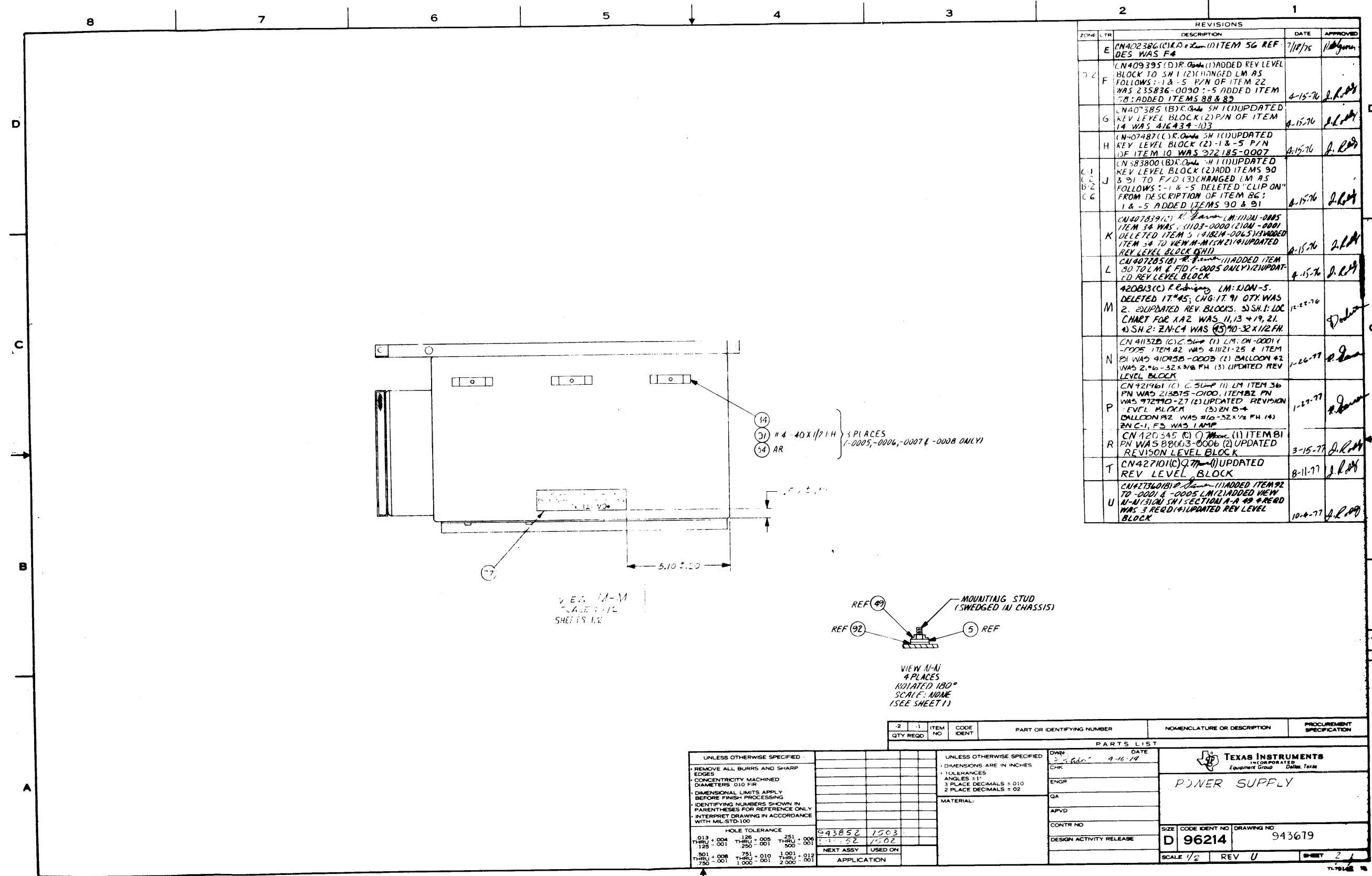

REVISIONS				
ZONE	LTR	DESCRIPTION	DATE	APPROVED
	E	CN402386 (C) R. O. O. (1) ITEM 56 REF DES WAS F4	7/10/75	J. R. O.
	F	CN409395 (D) R. O. O. (1) ADDED REV LEVEL BLOCK TO SH 1 (2) CHANGED LM AS FOLLOWS: -1 & -5 P/N OF ITEM 22 WAS 235836-0090; -5 ADDED ITEM 78; ADDED ITEMS 88 & 89	4-15-76	J. R. O.
	G	CN407385 (B) R. O. O. SH 1 (1) UPDATED REV LEVEL BLOCK (2) P/N OF ITEM 14 WAS 416434-103	4-15-76	J. R. O.
	H	CN407487 (C) R. O. O. SH 1 (1) UPDATED REV LEVEL BLOCK (2) -1 & -5 P/N OF ITEM 10 WAS 372185-0007	4-15-76	J. R. O.
C-1 C-2 B-2 C-6	J	CN583800 (B) R. O. O. SH 1 (1) UPDATED REV LEVEL BLOCK (2) ADD ITEMS 90 & 91 TO F/D (3) CHANGED LM AS FOLLOWS: -1 & -5 DELETED "CLIP ON" FROM DESCRIPTION OF ITEM 86; -1 & -5 ADDED ITEMS 90 & 91	4-15-76	J. R. O.
	K	CN407839 (C) R. O. O. LM: NON-005 ITEM 34 WAS 1103-0000 (2) LM-0001 DELETED ITEM 5, 14, 18, 21, 24, 25, 26, 27, 28, 29, 30, 31, 32, 33, 34, 35, 36, 37, 38, 39, 40, 41, 42, 43, 44, 45, 46, 47, 48, 49, 50, 51, 52, 53, 54, 55, 56, 57, 58, 59, 60, 61, 62, 63, 64, 65, 66, 67, 68, 69, 70, 71, 72, 73, 74, 75, 76, 77, 78, 79, 80, 81, 82, 83, 84, 85, 86, 87, 88, 89, 90, 91, 92, 93, 94, 95, 96, 97, 98, 99, 100	4-15-76	J. R. O.
	L	CN407205 (B) R. O. O. (1) ADDED ITEM 50 TO LM & F/D (-0005 ONLY) (2) UPDATED REV LEVEL BLOCK	4-15-76	J. R. O.
	M	420B13 (C) R. O. O. LM: NON-5. DELETED 17, 45; CHG: 17, 91 DTY WAS 2. 2) UPDATED REV BLOCKS. 3) SH 1: LOC CHART FOR 1A2 WAS 11, 13 + 19, 21. 4) SH 2: ZN: C4 WAS (5) 10-32 X 1/2 FH.	12-22-76	J. R. O.
	N	CN411320 (C) R. O. O. (1) LM: CN-0001 (-0005) ITEM 42 WAS 41121-25 & ITEM 21 WAS 410958-0003 (2) BALLOON #2 WAS 2" 10-32 X 3/8 FH (3) UPDATED REV LEVEL BLOCK	1-26-77	J. R. O.
	P	CN421961 (C) R. O. O. (1) LM ITEM 36 PN WAS 213015-0100, ITEM 22 PN WAS 972710-27 (2) UPDATED REVISION LEVEL BLOCK (3) ZN D-4 BALLOON #2 WAS #10-32 X 1/2 FH (4) ZN C-1, F3 WAS 1 AMP	1-27-77	J. R. O.
	R	CN120545 (C) R. O. O. (1) ITEM 81 PN WAS 88003-0006 (2) UPDATED REVISION LEVEL BLOCK	3-15-77	J. R. O.
	T	CN427101 (C) R. O. O. (1) UPDATED REV LEVEL BLOCK	8-11-77	J. R. O.
	U	CN427360 (B) R. O. O. (1) ADDED ITEM #2 TO -0001 & -0005 LM (2) ADDED VIEW A-A SECTION #4 & #9 (3) RECD WAS 3 RECD (4) UPDATED REV LEVEL BLOCK	10-4-77	J. R. O.

PARTS LIST				DATE		TEXAS INSTRUMENTS																		
QTY	REQD	ITEM NO	CODE IDENT	PART OR IDENTIFYING NUMBER	NOMENCLATURE OR DESCRIPTION	PROUREMENT SPECIFICATION	DATE																	
							4-16-74																	
UNLESS OTHERWISE SPECIFIED:				UNLESS OTHERWISE SPECIFIED:																				
<ul style="list-style-type: none"> REMOVE ALL BURRS AND SHARP EDGES CONCENTRICITY MACHINED DIAMETERS .010 FIR DIMENSIONAL LIMITS APPLY BEFORE FINISH PROCESSING IDENTIFYING NUMBERS SHOWN IN PARENTHESES FOR REFERENCE ONLY INTERPRET DRAWING IN ACCORDANCE WITH MIL-STD-100 				<ul style="list-style-type: none"> DIMENSIONS ARE IN INCHES TOLERANCES ANGLES ±1° 3 PLACE DECIMALS ± 0.10 2 PLACE DECIMALS ± 0.2 																				
<table border="1"> <tr> <th>HOLE TOLERANCE</th> <th>126</th> <th>251</th> </tr> <tr> <td>013 + .004</td> <td>THRU + .005</td> <td>THRU + .006</td> </tr> <tr> <td>125 + .001</td> <td>250 - .001</td> <td>500 - .001</td> </tr> </table>				HOLE TOLERANCE	126	251	013 + .004	THRU + .005	THRU + .006	125 + .001	250 - .001	500 - .001	<table border="1"> <tr> <td>943852</td> <td>7503</td> </tr> <tr> <td>52</td> <td>7502</td> </tr> <tr> <td>NEXT ASSY</td> <td>USED ON</td> </tr> <tr> <td>APPLICATION</td> <td></td> </tr> </table>				943852	7503	52	7502	NEXT ASSY	USED ON	APPLICATION	
HOLE TOLERANCE	126	251																						
013 + .004	THRU + .005	THRU + .006																						
125 + .001	250 - .001	500 - .001																						
943852	7503																							
52	7502																							
NEXT ASSY	USED ON																							
APPLICATION																								
<table border="1"> <tr> <th>SIZE</th> <th>CODE IDENT NO</th> <th>DRAWING NO</th> </tr> <tr> <td>D</td> <td>96214</td> <td>943679</td> </tr> </table>				SIZE	CODE IDENT NO	DRAWING NO	D	96214	943679	<table border="1"> <tr> <th>SCALE</th> <th>REV</th> <th>SHEET</th> </tr> <tr> <td>1/2</td> <td>U</td> <td>2</td> </tr> </table>				SCALE	REV	SHEET	1/2	U	2					
SIZE	CODE IDENT NO	DRAWING NO																						
D	96214	943679																						
SCALE	REV	SHEET																						
1/2	U	2																						



942773-9703

WIRE NO.	DESCRIPTION	TOTAL LENGTH	SIGNATURE	COMPONENT CONNECTION FOR START STATION	COMPONENT CONNECTION FOR FINISH STATION	REMARKS	NHA PL ITEM NO
1	NO 20 WHT/BLK IPVC	2"		J1-2	J1-4	INSTALL IT 20 ON BOTH ENDS	58
2	NO 20 WHT/BLK IPVC	18"	BAT-	J1-5	R1-1	INSTALL IT 20 AT J1 & P2	58
3	NO 20 WHT/BLK IPVC	25"	BAT-	A1P2-4	R1-1	50 AT R1	58
4	NO 20 WHT/R IPVC	7"	BAT+	J1-3	F3-2	INSTALL IT 20 AT J1 INSTALL IT 22 AT F3	59
5	NO 20 WHT/O IPVC	3"		F3-1	S1-1	INSTALL IT 22 AT F3 INSTALL IT 21 AT S1	60
6	NO 20 WHT/O IPVC	4"		S2-1	S1-1		60
7	NO 20 WHT/Y IPVC	21"	BAT LOAD+	S2-2	R1-2	INSTALL IT 50 AT R1	61
8	NO 20 WHT/R IPVC	27"	BAT + SW	S1-2	A1P2-5	INSTALL IT 20 AT P2 INSTALL IT 22 AT S1	59
9	XFMR WIRE BK		PRI- 115	T1-BK	TB1-1		5
10	XFMR WIRE BK/R		PRI- 115	T1-BK/R	TB1-1		5
11	XFMR WIRE G		PRI- 100	T1-G	TB1-2		5
12	XFMR WIRE G/R		PRI- 100	T1-G/R	TB1-4		5
13	XFMR WIRE BRN		PRI-LO	T1-BRN	TB1-5		5
14	XFMR WIRE BRN/R		PRI-LO	T1-BRN/R	TB1-5		5
15	XFMR WIRE G		SEC HV HI	T1-G	A1-J8		5
16	XFMR WIRE G		SEC HV LO	T1-G	A1-J9		5
17	XFMR WIRE R		SEC LV HI	T1-R	A1P2-3		5
18	XFMR WIRE R		SEC LV LO	T1-R	A1P2-6		5
19	XFMR WIRE WHT		SEC CT	T1-WHT	A1J3		5
20	PWR CORD BK		AC HI	BK	F5-2	INSTALL IT 21	15

SCALE	SIZE	CODE IDENT NO	DRAWING NO
A	A	96214	943681
REVISION	A		
SHEET	2		

Change 1

6-22

Digital Systems Division

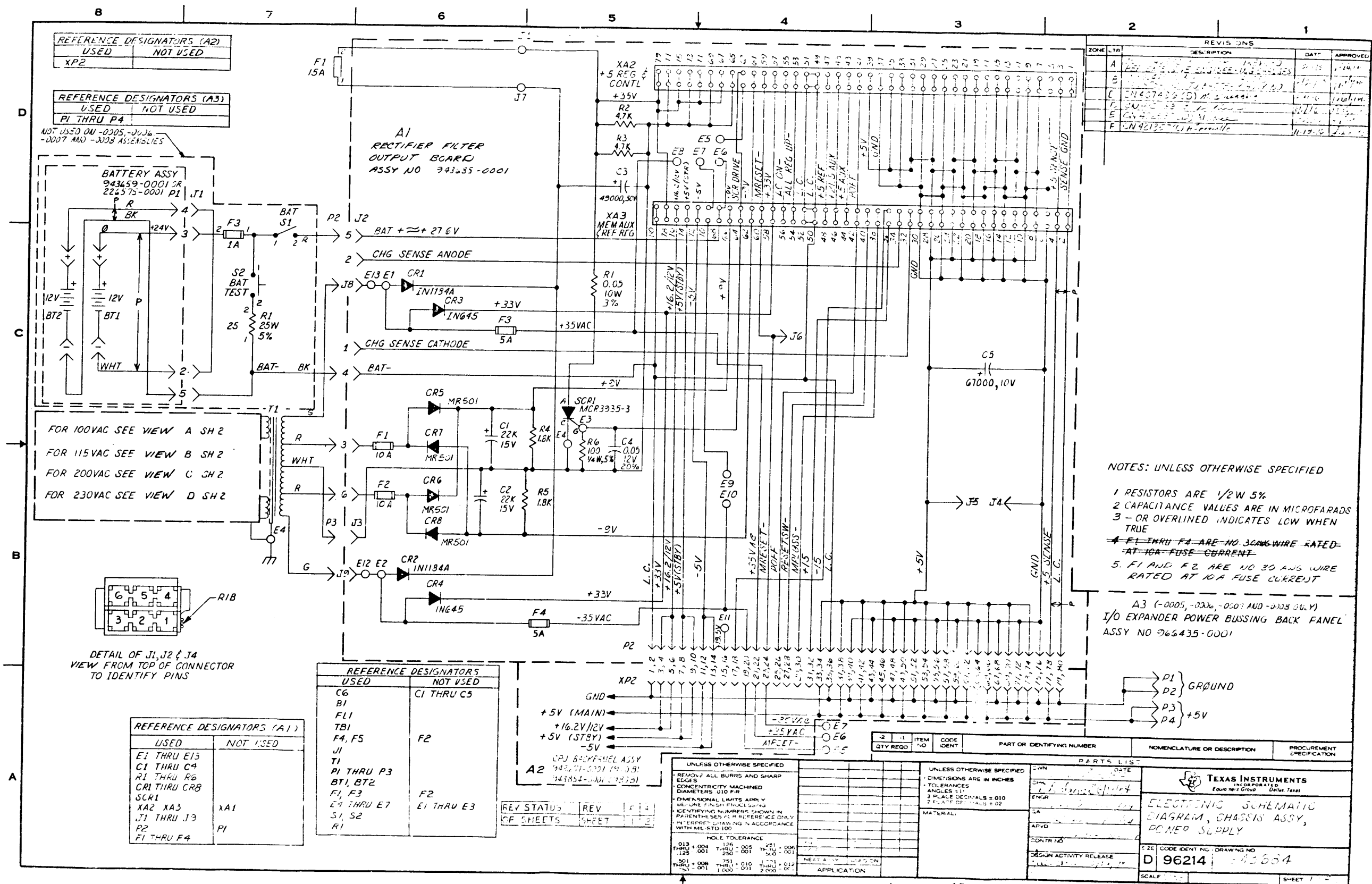

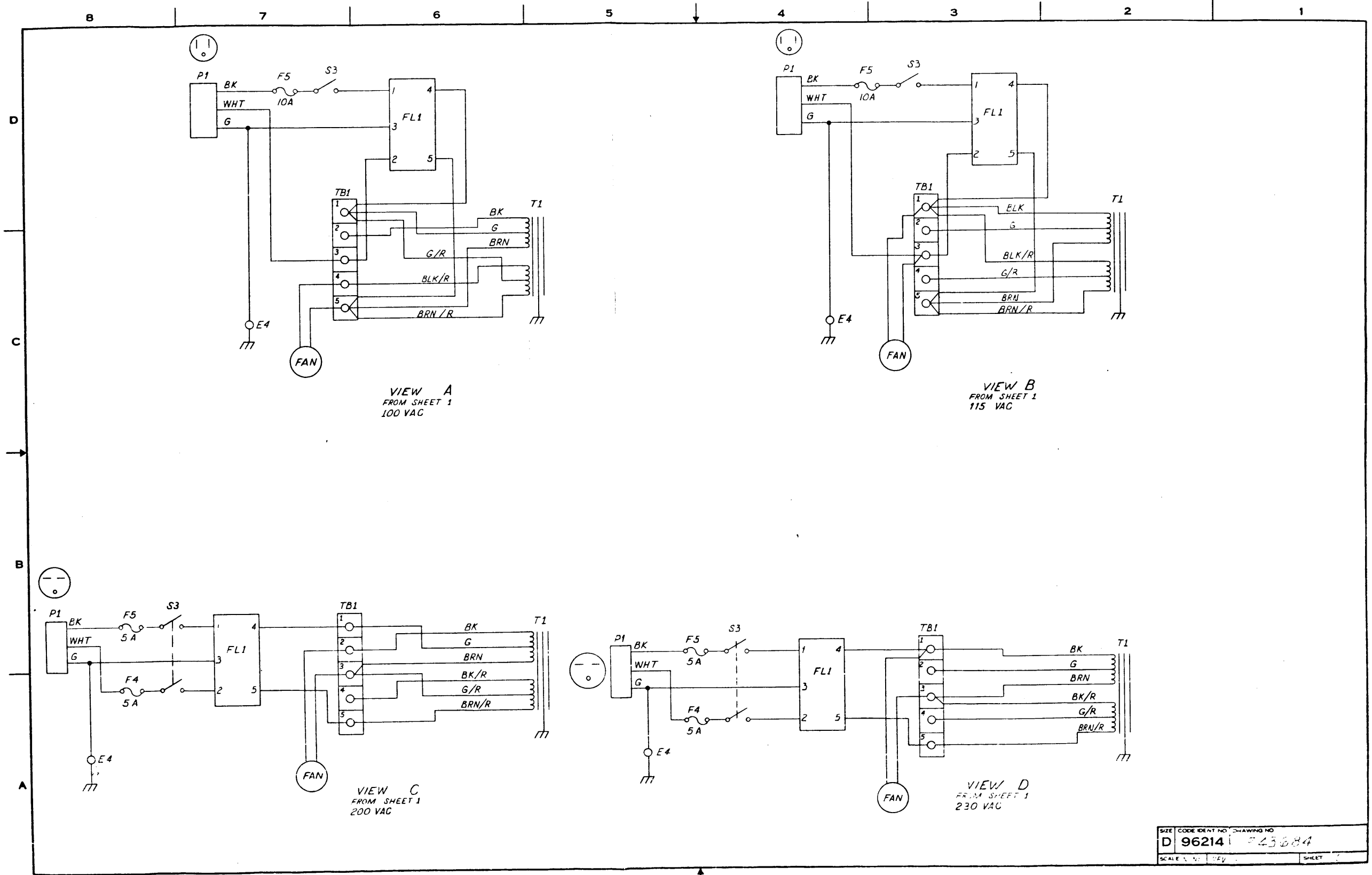

SIZE	CODE IDENT NO.	DRAWING NO.
D	96214	743684
SCALE	REV.	SHEET

Change 1

6-27

Digital Systems Division



TEXAS INSTRUMENTS
INCORPORATED

DATE 12/17/77

LIST of MATERIAL

PAGE 1 of

PART NUMBER	REV
LM 0943685-0001	AD

PRINT ITEM NUMBER	QUANTITY PER ASSEMBLY	UNIT OF ISSUE	DWG. SIZE	PART NUMBER	DESCRIPTION	VENDOR PART NUMBER	
0001	00001.000	EA		0943686-0001	PWB, RECTIFIER FILTER AND OUTPUT		
0002	REF	EA		0943684-9901	DIAG, SCHEMATIC, CHASSIS ASSY-CPU		
0003	REF	EA		0943688-9901	TEST PROCEDURE, REF-CARD		
0006	00002.000	EA		0231257-0009	CONNECTOR PC 80 PIN	FLC -00-6313080699	
0006A					XA2 XA3		
0007	00001.000	EA		0231254-0300	CONNECTOR HOUSING NYLON 6 CONTACTS	AMP -1-480333-1	
0007A					J2		
0008	00006.000	EA		0231553-0005	CONTACT PC SOLDER DIP	AMP -60905-1	
0009	00008.000	EA		0235837-1700	TERMINAL TAB EASTON .032 THICK BRASS	AMP -61570-1	
0009A					J1 J3 J4 J5 J6 J7 J8 J9		
0010	00001.000	EA		0231097-0008	CLAMP VR-8	MAL -VVR	
0011	00001.000	EA		0536026-0003	CLAMP, CAPICATOR		
0012	00003.000	EA		0972988-0028	SCREW 6-32 X .375 PAN HEAD CRCS		
0013	00006.000	EA		0972988-0027	SCREW 6-32 X .312 PAN HEAD CRCS		
0014	00013.000	EA		0411101-0058	LOCKWASHER #6 EXTERNAL TOOTH CRCS	GPL - MS35335-58	
0015	00008.000	EA		0972986-0008	SCREW 10-32 .375 PAN HEAD CRCS		
0016	00008.000	EA		0411101-0060	LOCKWASHER #10 EXTERNAL TOOTH CRCS	---	
0017	00004.000	EA		0416453-0022	NUT, PLAIN 6-32 UNC-28 HEX CRCS, SMALL	GPL - NAS67106	
0019	00006.000	EA		0411027-0805	WASHER, FLAT, .156ID X .312 OD X .035THK		
0021	00001.000	EA		0226733-0001	STIFFENER-CARD	01+00+04	
DRAFTSMAN		DATE	CKD. DRAFTSMAN	DATE	DESIGN ENGINEER	DATE	TITLE
			<i>J. R. Robb</i>	12-13-77			CARD ASSY, RECTIFIER, FILTER AND OUTPUT
APPD. MFG.		DATE	APPD. PROJECT ENGINEER	DATE	RELEASED	DATE	PROJECT NO.
							8100
						PART NUMBER	REV
						LM 0943685-0001	AD

T.I. 13849



942773-9703



TEXAS INSTRUMENTS
INCORPORATED

DATE 12/12/77

LIST OF MATERIAL

PAGE 2 of

LM	PART NUMBER 0943685-0001	REV AD
-----------	-----------------------------	-----------

PRINT ITEM NUMBER	QUANTITY PER ASSEMBLY	UNIT OF ISSUE	DWG. SIZE	PART NUMBER	DESCRIPTION	VENDOR PART NUMBER	
0022	00001.000	EA		0226732-0001	INSULATOR, CARD STIFFENER		
0025	AK	FT		0535978-0058	WIKE ELEC., SOLID, "KYNAR" INSUL #30 AWG		
0025A					F1 F2		
0026	00001.000	EA		0230590-9000	CAP .05 MF 12 V 20. % CER TRANSCAP	ERI -5635-000-Y5F05	
0026A					C3		
0027	00002.000	EA		0530734-0008	CAPACITOR 22000.MF 15V +75 -10%	SPR -360223G015AC2A	
0027A					C1 C2		
0029	00001.000	EA		0230983-0490	CAP 49000. MF 50V 75/-10	SAN -DCM493U050DE2B	
0029A					C3		
0030	00001.000	EA		0230983-0670	CAP 67000. MF 10V 75/-10	SAN -DCM673UG10RC2B	
0030A					C5		
0032	00002.000	EA		0539468-0003	DIODE, IN4003 JAMP 200PIV RECTIFIER	TI - IN4003	
0032A					CR3 CR4		
0033	00004.000	EA		0972164-0001	DIODE, MR501		
0033A					CR5 CR6 CR7 CR8		
0034	00002.000	EA		0231713-0001	DIODE IN1184A	WES -1N1184A	
0034A					CR1 CR2		
0035	00001.000	EA		0226721-0001	BRACKET-DIODE MTG 01+00+05		
0036	00002.000	EA		0996521-0014	INSULATOR GRAY .009 THERMALLY COND	055285-7403-09FR-25	
0037	00003.000	EA		0411101-0061	LOCKWASHER 1/4 EXTERNAL TOOTH CRES	OPL - MS35335-61	
DRAFTSMAN		DATE	CKD. DRAFTSMAN	DATE	DESIGN ENGINEER	DATE	TITLE
							CARD ASSY, RECTIFIER, FILTER AND OUTPUT
APPD.-MFG.		DATE	APPD. PROJECT ENGINEER	DATE	RELEASED	DATE	PROJECT NO.
						PART NUMBER	REV
						LM 0943685-0001	AD

T.I. 13849

Change 1

6-28

Digital Systems Division

942773-9703

Change 1

6-29

Digital Systems Division



TEXAS INSTRUMENTS
INCORPORATED

DATE 12/12/77

LIST OF MATERIAL

PAGE 3 of

LM 0943685-0001	PART NUMBER	REV
		AD

PRINT ITEM NUMBER	QUANTITY PER ASSEMBLY	UNIT OF ISSUE	DWG. SIZE	PART NUMBER	DESCRIPTION	VENDOR PART NUMBER	
0038	00003.000	EA		0411010-0003	NUT, JAM, HEXAGON	QPL - AN316-C4R	
0039	00001.000	EA		0232934-0050	RECTIFIER PNP SCR 35A W/HARDWARE	MOT - 2N3896	
0039A					SCR1		
0040	AK	FT		0410499-0009	INSULATION, SLEEVING #16 NATURAL	QPL - MIL-I-22129	
0041	AK	FT		0411400-0018	WIRE, BARE TINNED, 18AWG, COPPER BUS	IWP - 18-630	
0042	00000.500	FT		0538592-4999	WIRE #20 AWG SOLID WHITE TYPE ETFE	- 422759/XX-20	
0043	00001.000	EA		0972946-0041	RES FIX 100 OHM 5% .25 W CARBON FILM	ROH - R-25	
0043A					R6		
0044	00001.000	EA		0972687-0001	RES FIX 0.10 OHMS 10 WATT 5%		
0044A					R1		
0045	00002.000	EA		0972947-0071	RES FIX 1.8K OHM 5% .5 W CARBON FILM	ROH - R-50	
0045A					R4, R5		
0046	00010.000	EA		0085936-0012	EYELET .089 DIA PFL OD X .250 LG FLANGE	HSH - #SF-33	
0047	00001.000	EA		0972632-0012	STRAP, TIE DOWN, ADJUSTABLE, PLASTIC	PND - SSC-4H	
0048	AK	FT		0236528-0000	WIRE 22 AWG 1 COND WHITE TEFLON SOLID		
0049	AK	FT		0410499-0008	INSULATION SLEEVING, TEFLON #18 NATURAL	QPL - 81349	
0050	00002.000	EA		0537399-0012	FUSE 5AMP .014 OHM	LIT - 276005	
0050A					F3 F4		
0051	00008.000	EA		0234933-0000	FIVET PGP 1/8 DIA X 1/8 GRIP AL.	MIL - AN AJ4285	
0052	AK	QT		0415804-0005	SEALING COMPOUND, ANAEROBIC-BLUE GRADE C		
DRAFTSMAN		DATE	CKD. DRAFTSMAN	DATE	DESIGN ENGINEER	DATE	TITLE
							CARD ASSY, RECTIFIER, FILTER AND OUTPUT
APPD.-MFG		DATE	APPD. PROJECT ENGINEER	DATE	RELEASED	DATE	PROJECT NO.
						PART NUMBER	REV
						LM 0943685-0001	AD

T.I. 13849



942773-9703



TEXAS INSTRUMENTS
INCORPORATED

DATE 12/12/77

LIST OF MATERIAL

PAGE 4 of

LM 0943685-0001	PART NUMBER	REV
		AD

PRINT ITEM NUMBER	QUANTITY PER ASSEMBLY	UNIT OF ISSUE	DWG. SIZE	PART NUMBER	DESCRIPTION	VENDOR PART NUMBER
0053	AR	TU		0415804-0011	SURFACE PRIMER, COMPOUND GRADE T YELLOW	
0054	00002.000	EA		0972947-0081	RES FIX 4.7K OHM 5% .5 W CARBON FILM	ROH - R-50
0054A					R2, R3	
0055	00000.800	FT		0417682-9299	WIRE HOOKUP 16 AWG TYPE B INS RD/WH	JUD - HH0205
0056	00000.600	FT		0417682-9099	WIRE HOOKUP 16 AWG TYPE B INS BK/WH	JUD - HH0205
0057	00002.000	EA		0411116-0104	NUT, PLAIN HEX, #10	
0058	00004.000	EA		0232354-0004	LUG #10 RING TONGUE VINYL INS AWG 22-16	AMP -31889 ON TAPE
0059	00001.000	EA		0972632-0001	STRAP, TIE DOWN, CABLE-NON-STD, 0-1-1/4 D.	

DRAFTSMAN	DATE	CKD. DRAFTSMAN	DATE	DESIGN ENGINEER	DATE	TITLE
						CARD ASSY, RECTIFIER, FILTER AND OUTPUT
APPD. MFG.	DATE	APPD. PROJECT ENGINEER	DATE	RELEASED	DATE	PROJECT NO.

LM 0943685-0001	PART NUMBER	REV
		AD

T.I. 13849

Change 1

6-30

Digital Systems Division

942773-9703

Change 1

6-31

Digital Systems Division



TEXAS INSTRUMENTS
INCORPORATED

DATE 12/12/77

LIST OF MATERIAL

PAGE 1 of

LM PART NUMBER 0943685-0002 REV AD

PRINT ITEM NUMBER	QUANTITY PER ASSEMBLY	UNIT OF ISSUE	DWG. SIZE	PART NUMBER	DESCRIPTION	VENDOR PART NUMBER	
0001	00001.000	EA		0943686-0001	PWB, RECTIFIER FILTER AND OUTPUT		
0002	REF	FA		0943684-9901	DIAG, SCHEMATIC, CHASSIS ASSY-CPU		
0003	REF	FA		0943688-9901	TEST PROCEDURE, KFO-CARD		
0006	00002.000	EA		0231257-0009	CONNECTOR PC 80 PIN	ELC -00-6313080699	
0006A					XA2 XA3		
0007	00001.000	EA		0231254-0300	CONNECTOR HOUSING NYLON 6 CONTACTS	AMP -1-480333-1	
0007A					J2		
0008	00006.000	EA		0231553-0005	CONTACT PC SOLDER DIP	AMP -60905-1	
0009	00008.000	EA		0235837-1700	TERMINAL TAB FASTON .032 THICK BRASS	AMP -61570-1	
0009A					J1 J3 J4 J5 J6 J7 J8 J9		
0010	00001.000	EA		0231097-0003	CLAMP VR-8	MAL -VR8	
0011	00001.000	EA		0536026-0003	CLAMP, CAPICATOR		
0012	00003.000	FA		0972988-0028	SCREW 6-32 X .375 PAN HEAD CRES		
0013	00006.000	EA		0972988-0027	SCREW 6-32 X .312 PAN HEAD CRES		
0014	00013.000	EA		0411101-0058	LOCKWASHER #6 EXTERNAL TOOTH CRES	QPL - MS35335-58	
0015	00008.000	EA		0972986-0008	SCREW 10-32 .375 PAN HEAD CRES		
0016	00008.000	EA		0411101-0060	LOCKWASHER #10 EXTERNAL TOOTH CRES	---	
0017	00004.000	FA		0411115-0064	NUT, PLAIN 6-32 UNC-2B HEX CRES	QPL - MS35649-264	
0019	00006.000	FA		0411027-0805	WASHER, FLAT, .15610 X .312 OD X .035THK		
0021	00001.000	EA		0226733-0001	STIFFENER-CARD	01+00+04	
DRAFTSMAN		DATE	CKD. DRAFTSMAN	DATE	DESIGN ENGINEER	DATE	TITLE
APPD.-MFG		DATE	APPD. PROJECT ENGINEER	DATE	RELEASED	DATE	PROJECT NO.
							LM PART NUMBER 0943685-0002 REV AD

T.I. 13849



942773-9703



TEXAS INSTRUMENTS
INCORPORATED

DATE 12/12/77

LIST OF MATERIAL

PAGE 2 of

PART NUMBER
LM 0943685-0002

REV
AD

PRINT ITEM NUMBER	QUANTITY PER ASSEMBLY	UNIT OF ISSUE	DWG SIZE	PART NUMBER	DESCRIPTION	VENDOR PART NUMBER	
0022	00001.000	FA		0226732-0001	INSULATOR, CARD STIFFENER		
0025	AK	FT		0535978-0058	WIRE FLEC., SOLID, "KYNAR" INSUL #30 AWG		
0025A					F1 F2		
0026	00001.000	FA		0230590-9000	CAP .05 MF 12 V 20. % CER TRANSCAP	FRI -5635-000-Y5F05	
0026A					C4		
0027	00002.000	FA		0530734-0008	CAPACITOR 22000.MF 15V +75 -10%	SPR -360223G015AC2A	
0027A					C1 C2		
0029	00001.000	EA		0230983-0490	CAP 49000. MF 50V 75/-10	SAN -00M4930050DF28	
0029A					C3		
0030	00001.000	EA		0230983-0670	CAP 67000. MF 10V 75/-10	SAN -00M6730010BC28	
0030A					C5		
0032	00002.000	FA		0539468-0003	DIODE, 1N4003 1AMP 200PIV RECTIFIER	TI - 1N4003	
0032A					CR3 CR4		
0033	00004.000	EA		0972164-0001	DIODE, MR501		
0033A					CR5 CR6 CR7 CR8		
0034	00002.000	FA		0231713-0001	DIODE 1N1184A	WES -1N1184A	
0034A					CR1 CR2		
0035	00001.000	EA		0226721-0001	BRACKET-DIODE MTG	01+00+05	
0036	00002.000	FA		0996521-0014	INSULATOR GRAY .009 THERMALLY COND	055285-7403-09FR-25	
0037	00003.000	EA		0411101-0061	LOCKWASHER 1/4 EXTERNAL TOOTH CRES	QPL - M535335-61	
DRAFTSMAN		DATE	CKD. DRAFTSMAN	DATE	DESIGN ENGINEER	DATE	TITLE
							CARD ASSY, RECTIFIER, FILTER AND OUTPUT
APPD.-MFG.		DATE	APPD. PROJECT ENGINEER	DATE	RELEASED	DATE	PROJECT NO.
						PART NUMBER	REV
						LM 0943685-0002	AD

T.I. 13849

Change 1

6-32

Digital Systems Division

942773-9703



TEXAS INSTRUMENTS
INCORPORATED

DATE 12/12/77

LIST OF MATERIAL

PAGE 3 of

PART NUMBER	REV
LM 0943685-0002	AD

PRINT ITEM NUMBER	QUANTITY PER ASSEMBLY	UNIT OF ISSUE	DWG. SIZE	PART NUMBER	DESCRIPTION	VENDOR PART NUMBER	
0038	00003.000	EA		0411010-0003	NUT,JAM,HEXAGON	QPL - AN316-C4R	
0039	00001.000	EA		0232934-0050	RECTIFIER PNP SCR 35A W/HARDWARE	MUT -2N3896	
0039A					SCR1		
0040	AR	FT		0410499-0009	INSULATION,SLEEVING #16 NATURAL	QPL - MIL-I-22129	
0041	AR	FT		0411400-0018	WIRE,BARE TINNED,18AWG, COPPER BUS	IWP -18-630	
0042	00000.500	FT		0538592-4999	WIRE #20 AWG SOLID WHITE TYPE ETFE	- M27759/XX-20	
0043	00001.000	EA		0972946-0041	PES FIX 100 OHM 5% .25 W CARBON FILM	ROH - R-25	
0043A					R6		
0044	00001.000	EA		0972687-0001	PES FIX 0.10 OHMS 10 WATT 5%		
0044A					R1		
0045	00002.000	EA		0972947-0071	PES FIX 1.8K OHM 5% .5 W CARBON FILM	ROH - R-50	
0045A					R4,R5		
0046	00010.000	EA		0085936-0012	EYELET .089 BARREL OD X .250 LG FLANGE	USH - #SE-38	
0047	00001.000	EA		0972632-0012	STRAP,TIEDOWN,ADJUSTABLE,PLASTIC	PND - SSC-4H	
0048	AR	FT		0236528-0000	WIRE 22 AWG 1 COND WHITE TEFLON SOLID		
0049	AR	FT		0410499-0006	INSULATION SLEEVING,TEFLON #18 NATURAL	QPL -81349	
0050	00002.000	EA		0537399-0012	FUSE 5AMP .014 OHM	LIT -276005	
0050A					F3 F4		
0051	00008.000	EA		0234933-0000	RIVET POP 1/8 DIA X 1/8 GRIP AL.	MIL -AN AD42ABS	
0052	AR	UT		0415804-0005	SEALING COMPOUND,ANAEROBIC-BLUE GRADE C		
DRAFTSMAN		DATE	CKD DRAFTSMAN	DATE	DESIGN ENGINEER	DATE	TITLE
							CARD ASSY,RECTIFIFR,FILTER AND OUTPUT
APPD.-MFG.		DATE	APPD. PROJECT ENGINEER	DATE	RELEASED	DATE	PROJECT NO.
						PART NUMBER	REV
						LM 0943685-0002	AD





TEXAS INSTRUMENTS
INCORPORATED

DATE 12/12/77

LIST OF MATERIAL

PAGE 4 of

LM	PART NUMBER 0943685-0002	REV AD
-----------	-----------------------------	-----------

PRINT ITEM NUMBER	QUANTITY PER ASSEMBLY	UNIT OF ISSUE	DWG. SIZE	PART NUMBER	DESCRIPTION	VENDOR PART NUMBER
0053	AR	TU		0415804-0011	SURFACE PRIMER, COMPOUND GRADE T YELLOW	
0054	00002.000	EA		0972947-0081	RES FIX 4.7K OHM 5% .5 W CARBON FILM	POH - R-50
0054A					K2, K3	
0055	00000.800	FT		0417682-9299	WIRE HOOKUP 16 AWG TYPE B INS RD/WH	JUD - HH0205
0056	00000.800	FT		0417682-9099	WIRE HOOKUP 16 AWG TYPE B INS BK/WH	JUD - HH0205
0057	00002.000	EA		0411116-0104	NUT, PLAIN HEX, #10	
0058	00004.000	EA		0232354-0004	LUG #10 KING TONGUE VINYL INS AWG 22-16	AMP -31889 ON TAPE
0059	00001.000	EA		0972637-0001	STRAP, TIE DOWN, CABLE-NON-STD, 0-1-1/4 D.	

DRAFTSMAN	DATE	CKD. DRAFTSMAN	DATE	DESIGN ENGINEER	DATE	TITLE
						CARD ASSY, RECTIFIER, FILTER AND OUTPUT
APPD. MFG.	DATE	APPD. PROJECT ENGINEER	DATE	RELEASED	DATE	PROJECT NO.

LM	PART NUMBER 0943685-0002	REV AD
-----------	-----------------------------	-----------

T.I. 13849

Change 1

6-34

Digital Systems Division

942773-9703



DESCRIPTION	TOTAL QUANTITY	START STATION	FINISH STATION	COMPONENT CONNECTION FOR START STATION	COMPONENT CONNECTION FOR FINISH STATION	REMARKS	NHA ITEM NO.
#22 INSUL BUS				E9	E10	-0001 ONLY	45
#22 INSUL BUS				E7	E8	-0001 ONLY	43
#22 INSUL BUS				E5	E6	-0001 ONLY	42
#20 INSUL BUS				E2	CR2-A	-0001 & -0002	40
#20 INSUL BUS				E12	CR2-A	-0001 & -0002	42
#20 INSUL BUS				E1	CR1-A	-0001 & -0002	42
#20 INSUL BUS				E13	CR1-A	-0001 & -0002	42
#22 INSUL BUS				E3	SCR1-G	-0001 & -0002	48
#18 AWG BUS				E4	SCR1-C	-0001 & -0002	41
#22 INSUL BUS				E9	E11	-0002 ONLY	48
#16 AWG RED/WHT				E14	C3-(+)	-0001 & -0002	55
#16 AWG BLK/WHT				E15	C3-(-)	-0001 & -0002	56

NOTES CONT

8 ITEM 49 SLEEVING MUST BE USED ON F1 & F2

NOTES CONT (E1)

4 SOLDER WIRE 34 USE 36, 37, 38, 39 TO SOLDER WIRE TO HEIGHT .12 DIA. BEND TAP IN 1/16" DIA. 1/16" DIA. SOLDER IN 1/16" DIA. ID.

5 ITEM 25 INSULATION IS OPTIONAL, HOWEVER ITEM 49 MUST BE USED ON #2, #3, #4 AND #5

7 SEAL PER PROCESS 3

NOTES:

1. MAXIMUM LEAD LENGTH FROM CONDUCTOR SIDE OF EARL IS .015

2. CLEANING COMPONENT LEADS ON R1 AND E4

3. ITEMS 10, 11, 27, 29, 30, 34 & 39 VENDOR SUPPLIED HARDWARE MAY BE USED FOR MOUNTING. EXT TOOTH LOCK WASHERS MUST BE USED WHERE CALLED FOR.

REVISIONS

ZONE	LTR	DESCRIPTION	DATE	APPROVED
	A	DELETED ITEM 49 TO FID -0001 LM AND -0002 LM (2) UPDATED REV LEVEL BLOCK	11/21/74	Religion
	B	DELETED ITEM 49 TO FID -0001 LM AND -0002 LM (2) UPDATED REV LEVEL BLOCK	3/5/75	Religion
	C	DELETED ITEM 49 TO FID -0001 LM AND -0002 LM (2) UPDATED REV LEVEL BLOCK	9/21/75	Religion
	D	DELETED ITEM 49 TO FID -0001 LM AND -0002 LM (2) UPDATED REV LEVEL BLOCK	6/19/75	Religion
	E	DELETED ITEM 49 TO FID -0001 LM AND -0002 LM (2) UPDATED REV LEVEL BLOCK	7/16/75	Religion
	F	DELETED ITEM 49 TO FID -0001 LM AND -0002 LM (2) UPDATED REV LEVEL BLOCK	8/19/75	Religion
	G	DELETED ITEM 49 TO FID -0001 LM AND -0002 LM (2) UPDATED REV LEVEL BLOCK	10/31/75	Religion
	H	DELETED ITEM 49 TO FID -0001 LM AND -0002 LM (2) UPDATED REV LEVEL BLOCK	10/31/75	Religion
	I	DELETED ITEM 49 TO FID -0001 LM AND -0002 LM (2) UPDATED REV LEVEL BLOCK	3/1/76	Religion
	J	DELETED ITEM 49 TO FID -0001 LM AND -0002 LM (2) UPDATED REV LEVEL BLOCK	7/16/76	Religion
	K	DELETED ITEM 49 TO FID -0001 LM AND -0002 LM (2) UPDATED REV LEVEL BLOCK	7/16/76	Religion
	L	DELETED ITEM 49 TO FID -0001 LM AND -0002 LM (2) UPDATED REV LEVEL BLOCK	7/16/76	Religion
	M	DELETED ITEM 49 TO FID -0001 LM AND -0002 LM (2) UPDATED REV LEVEL BLOCK	7/16/76	Religion
	N	DELETED ITEM 49 TO FID -0001 LM AND -0002 LM (2) UPDATED REV LEVEL BLOCK	7/16/76	Religion
	O	DELETED ITEM 49 TO FID -0001 LM AND -0002 LM (2) UPDATED REV LEVEL BLOCK	7/16/76	Religion
	P	DELETED ITEM 49 TO FID -0001 LM AND -0002 LM (2) UPDATED REV LEVEL BLOCK	7/16/76	Religion
	Q	DELETED ITEM 49 TO FID -0001 LM AND -0002 LM (2) UPDATED REV LEVEL BLOCK	7/16/76	Religion
	R	DELETED ITEM 49 TO FID -0001 LM AND -0002 LM (2) UPDATED REV LEVEL BLOCK	7/16/76	Religion
	S	DELETED ITEM 49 TO FID -0001 LM AND -0002 LM (2) UPDATED REV LEVEL BLOCK	7/16/76	Religion
	T	DELETED ITEM 49 TO FID -0001 LM AND -0002 LM (2) UPDATED REV LEVEL BLOCK	7/16/76	Religion
	U	DELETED ITEM 49 TO FID -0001 LM AND -0002 LM (2) UPDATED REV LEVEL BLOCK	7/16/76	Religion
	V	DELETED ITEM 49 TO FID -0001 LM AND -0002 LM (2) UPDATED REV LEVEL BLOCK	7/16/76	Religion
	W	DELETED ITEM 49 TO FID -0001 LM AND -0002 LM (2) UPDATED REV LEVEL BLOCK	7/16/76	Religion
	X	DELETED ITEM 49 TO FID -0001 LM AND -0002 LM (2) UPDATED REV LEVEL BLOCK	7/16/76	Religion
	Y	DELETED ITEM 49 TO FID -0001 LM AND -0002 LM (2) UPDATED REV LEVEL BLOCK	7/16/76	Religion

MARK APPROPRIATE LEAD AND REV LEVEL PER REV LEVEL BLOCK

SECTION C-C (R1, C5, C6, SP7, CR4)

SECTION A-A (STUD (ANODE) SHORT (GATE) PLATE ANODE)

VIEW D-D (J1, J7)

TEST PROCEDURE (943688-9901)

DIAGRAM	D	E	F	F	F	F	F	F	F
PWB	G	G	M	H	H	J	K	L	L
ASSEMBLY	T	U	V	W	Y	AA	AB	AC	AD

PROCESSES:

1. SOLDER PER F-127, METHOD I

2. MARK PER FIG. TYPE II CLASS 1, HEIGHT .09, COLOR BLACK

3. SEAL PER F-127

REV LEVEL BLOCK

CONT. EUMF A-5

TEST PROCEDURE (943688-9901)

DIAGRAM	D	E	F	F	F	F	F	F	F
PWB	G	G	M	H	H	J	K	L	L
ASSEMBLY	T	U	V	W	Y	AA	AB	AC	AD

PROCESSES:

1. SOLDER PER F-127, METHOD I

2. MARK PER FIG. TYPE II CLASS 1, HEIGHT .09, COLOR BLACK

3. SEAL PER F-127

REV LEVEL BLOCK

CONT. EUMF A-5

TEST PROCEDURE (943688-9901)

DIAGRAM	D	E	F	F	F	F	F	F	F
PWB	G	G	M	H	H	J	K	L	L
ASSEMBLY	T	U	V	W	Y	AA	AB	AC	AD

PROCESSES:

1. SOLDER PER F-127, METHOD I

2. MARK PER FIG. TYPE II CLASS 1, HEIGHT .09, COLOR BLACK

3. SEAL PER F-127

REV LEVEL BLOCK

CONT. EUMF A-5

TEST PROCEDURE (943688-9901)

DIAGRAM	D	E	F	F	F	F	F	F	F
PWB	G	G	M	H	H	J	K	L	L
ASSEMBLY	T	U	V	W	Y	AA	AB	AC	AD

PROCESSES:

1. SOLDER PER F-127, METHOD I

2. MARK PER FIG. TYPE II CLASS 1, HEIGHT .09, COLOR BLACK

3. SEAL PER F-127

REV LEVEL BLOCK

CONT. EUMF A-5

TEST PROCEDURE (943688-9901)

DIAGRAM	D	E	F	F	F	F	F	F	F
PWB	G	G	M	H	H	J	K	L	L
ASSEMBLY	T	U	V	W	Y	AA	AB	AC	AD

PROCESSES:

1. SOLDER PER F-127, METHOD I

2. MARK PER FIG. TYPE II CLASS 1, HEIGHT .09, COLOR BLACK

3. SEAL PER F-127

REV LEVEL BLOCK

CONT. EUMF A-5

REV	DATE	BY	AD	AD
1				
2				

QTY	REV	ITEM NO.	CODE IDENT	PART OR IDENTIFYING NUMBER	NOMENCLATURE OR DESCRIPTION	PROCUREMENT SPECIFICATION

UNLESS OTHERWISE SPECIFIED	UNLESS OTHERWISE SPECIFIED
REMOVE ALL BURRS AND SHARP EDGES	DIMENSIONS ARE IN INCHES
CONCENTRICITY MACHINED DIAMETERS .010 FIR	TOLERANCES
DIMENSIONAL LIMITS APPLY BEFORE FINISH PROCESSING	ANGLES ±1°
IDENTIFYING NUMBERS SHOWN IN PARENTHESES FOR REFERENCE ONLY	3 PLACE DECIMALS ±.010
INTERPRET DRAWING IN ACCORDANCE WITH MIL-STD-100	2 PLACE DECIMALS ±.02

HOLE TOLERANCE	APPLY TO
Ø13 +.004	THRU .001
125 +.005	THRU .001
251 +.006	THRU .001
Ø13 +.004	THRU .001
125 +.005	THRU .001
251 +.006	THRU .001

DATE	BY	REV
3/5/74	Religion	1
7/16/74	Religion	2
7/16/74	Religion	3
7/16/74	Religion	4
7/16/74	Religion	5
7/16/74	Religion	6
7/16/74	Religion	7
7/16/74	Religion	8
7/16/74	Religion	9
7/16/74	Religion	10
7/16/74	Religion	11
7/16/74	Religion	12
7/16/74	Religion	13
7/16/74	Religion	14
7/16/74	Religion	15
7/16/74	Religion	16
7/16/74	Religion	17
7/16/74	Religion	18
7/16/74	Religion	19
7/16/74	Religion	20
7/16/74	Religion	21
7/16/74	Religion	22
7/16/74	Religion	23
7/16/74	Religion	24
7/16/74	Religion	25
7/16/74	Religion	26
7/16/74	Religion	27
7/16/74	Religion	28
7/16/74	Religion	29
7/16/74	Religion	30
7/16/74	Religion	31
7/16/74	Religion	32

DESIGN ACTIVITY/RELEASE	DATE	BY
DESIGN	7/16/74	Religion
RELEASE	7/16/74	Religion

SIZE	CODE IDENT NO.	DRAWING NO.
D	96214	943685

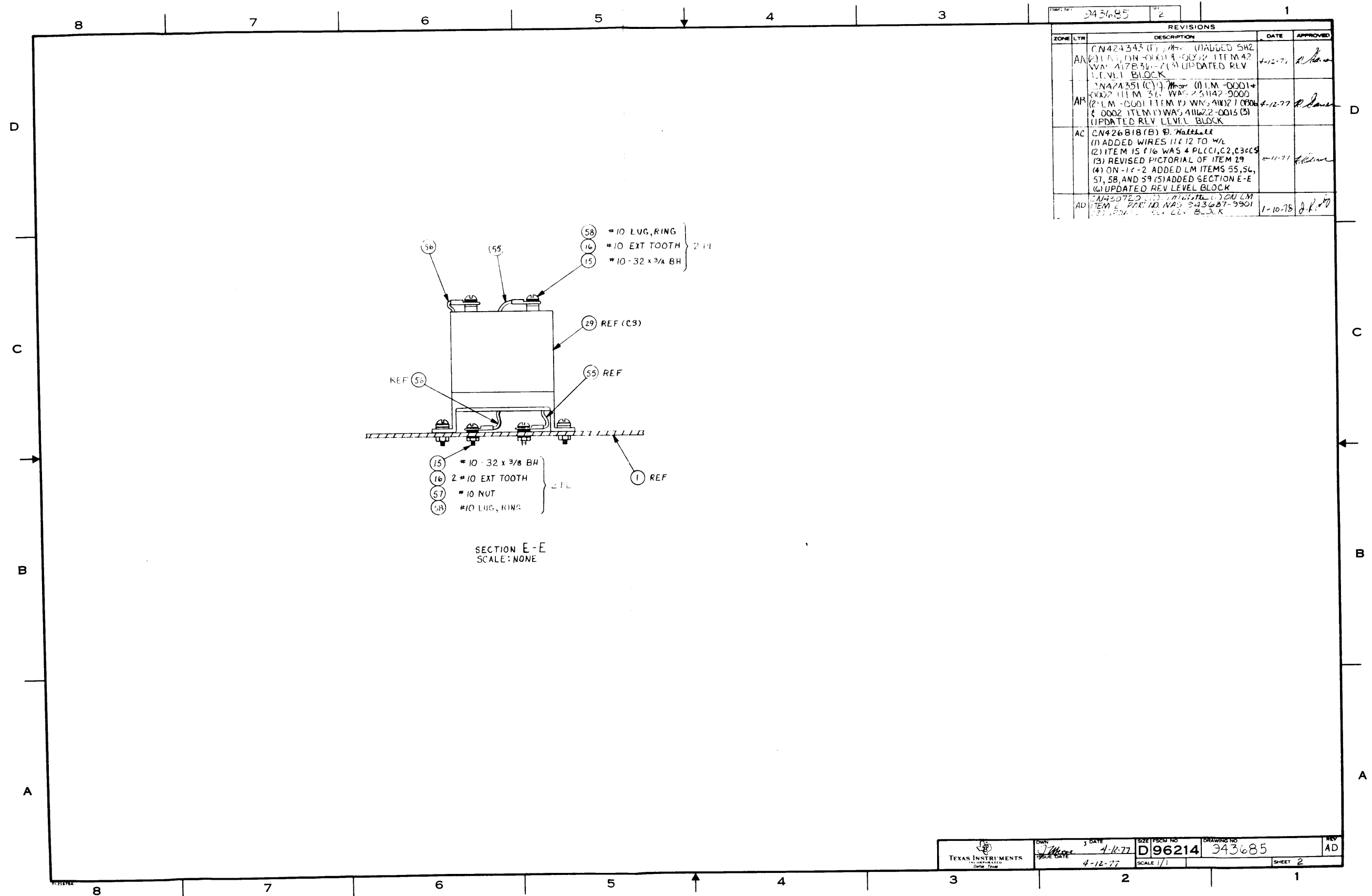

Change 1

6-37

Digital Systems Division



TEXAS INSTRUMENTS
INCORPORATED

DATE 12/22/77

LIST OF MATERIAL

PAGE 1 of

PART NUMBER	REV
LM 0943685-0001	W

PRINT ITEM NUMBER	QUANTITY PER ASSEMBLY	UNIT OF ISSUE	DWG. SIZE	PART NUMBER	DESCRIPTION	VENDOR PART NUMBER	
0001	00001.000	EA		0943690-0001	PWB, +5V MAIN REG & CGNT		
0002	REF	EA		0943691-9901	DIAG, SCHEM, +5V MAIN REG & CGNT		
0004	00001.000	EA		0226594-0001	HEATSINK-+5V MAIN REG & CONTROL 01+00+04		
0005	00015.000	EA		0185113-0001	X SPACER XST TC-18 CASE	* -	
0006	00003.000	EA		0184262-0001	PAD, MOUNTING, TO-5, 4 LEAD, RED	THR - 7717-5	
0007	AR	FT		0410499-0013	INSULATION, SLEEVING # 8 NATURAL	QPL - MIL-I 22129	
0008	AR	FT		0410499-0010	INSULATION SLEEVING, TEFLON #14 NATURAL	QPL - 81349	
0011	00002.000	EA		0419368-0002	HEATSINK, TRANSISTOR	WAK - NF-207	
0012	00001.000	EA		0972957-0001	TRANSISTOR, 2N930A NPN LOW CUR AMP, TO-18	MOT - 2N930A	
0012A					Q10		
0014	AR	FT		0411400-0016	WIRE, 16AWG, SOLID, UNINSULATED		
0015	AR	EA		0235182-0002	LOCTITE SEALANT GRADE 242	LOC --242	
0016	00002.000	EA		0234866-0100	RING O 7/32X11/32X1/16	P-K -2-009-N219-7	
0017	00002.000	EA		0416622-0033	WASHER #10 FLAT	QPL - AN960C10L	
0019	00002.000	EA		0226578-0001	REACTOR, 15 AMP		
0019A					L1 L2		
0020	00004.000	EA		0235057-0001	SCREW 6-32X9/16 BH SST		
0021	00004.000	EA		0411115-0044	NUT, 4-40 HEXAGCN CRES STEEL	MS -35649-244	
0022	00002.000	EA		0972988-0015	SCREW 4-40 X .375 PAN HEAD CRES		
0023	00010.000	EA		0411101-0057	LOCKWASHER # 4 EXTERNAL TOOTH CRES	QPL - MS35335-57	
DRAFTSMAN		DATE	CKD. DRAFTSMAN	DATE	DESIGN ENGINEER	DATE	TITLE
			<i>J. Rowe</i>	1-3-78			CARD ASSY, PWB, +5V MAIN REG & CONTROL
APPD. MFG.		DATE	APPD. PROJECT ENGINEER	DATE	RELEASED	DATE	PROJECT NO.
							7502
						PART NUMBER	REV
						LM 0943685-0001	W

T.I. 13849



942773-9703



TEXAS INSTRUMENTS
INCORPORATED

DATE 12/22/77

LIST OF MATERIAL

PAGE 2 of

PART NUMBER	REV
LM 0943689-0001	W

PRINT ITEM NUMBER	QUANTITY PER ASSEMBLY	UNIT OF ISSUE	DWG. SIZE	PART NUMBER	DESCRIPTION	VENDOR PART NUMBER	
0024	00002.000	EA		0996521-0006	INSULATOR GRAY .009 THERMALLY COND	J55285-7403-09FK-11	
0025	AR	EA		0231142-9000	CGMPOUND THERMACOTE, 2 OZ JAR NGN-TOXIC	THR -250	
0026	00002.000	EA		0972934-0014	DIODE, 1N759A 12.0 V 5% SIL VOLT REG	QPL - 1N759A	
0026A					CR1 CR2		
0027	00002.000	EA		0972124-0001	RECTIFIER, SILICON	RCA --D2540FR	
0027A					P/N 538043-0007 MAY BE		
0027B					SUBSTITUTED		
0027C					CR8 CR11		
0028	00001.000	EA		0972934-0006	DIODE, 1N751A 5.1 V 5% SIL VOLT REG	QPL - 1N751A	
0028A					CR18		
0029	00001.000	EA		0972934-0007	DIODE, 1N752A 5.6 V 5% SIL VOLT REG	QPL - 1N752A	
0029A					CR12		
0030	00002.000	EA		0236091-5300	XST 2N5302	TI -2N5302	
0030A					Q14 Q16		
0031	00009.000	EA		0972948-0002	TRANSISTOR, 2N2222A NPN GEN PURP SW TO-18	TI - 2N2222A	
0031A					Q1 Q2 Q3 Q4 Q5 Q6 Q9 Q11		
0031B					Q12		
0032	00004.000	EA		0972958-0002	TRANSISTOR, 2N2907A PNP GEN PURP SW TO-18	TI - 2N2907A	
0032A					Q7 Q8 Q13 Q21		
0033	00002.000	EA		0418288-0001	TRANSISTOR, 2N1711	QPL - 2N1711	
DRAFTSMAN		DATE	CRD. DRAFTSMAN	DATE	DESIGN ENGINEER	DATE	TITLE
							CARD ASSY, PWB, +5V MAIN REG & CONTROL
APPD. MFG.		DATE	APPD. PROJECT ENGINEER	DATE	RELEASED	DATE	PROJECT NO.
						PART NUMBER	REV
						LM 0943689-0001	W

T.I. 13849

Change 1

6-38

Digital Systems Division

942773-9703

Change 1

6-39

Digital Systems Division



TEXAS INSTRUMENTS
INCORPORATED

DATE 12/22/77

LIST OF MATERIAL

PAGE 3 of

PART NUMBER REV
LM 0943685-0001 h

PRINT ITEM NUMBER	QUANTITY PER ASSEMBLY	UNIT OF ISSUE	DWG. SIZE	PART NUMBER	DESCRIPTION	VENDOR PART NUMBER	
0033A					Q15 Q20		
0034	00002.000	EA		0236091-0015	XST- 2N3740	MOT -2N3740	
0034A					Q17 Q18		
0035	00001.000	EA		0972714-0001	THERMISTOR-GLASS FRCBE MTD, 200K OHM		
0035A					R81		
0036	00002.000	EA		0996521-0003	INSULATOR GRAY .009 THERMALLY COND	055285-7403-09FK-04	
0037	00002.000	EA		0235341-0000	SOCKET XST TO-3 CASE	EBY -9866-15-1	
0038	00002.000	EA		0222222-7400	NETWORK SN7400N	-SN7400N	
0038A					U3 U4		
0039	00001.000	EA		0222222-7403	NETWORK SN7403N		
0039A					L1		
0040	00001.000	EA		0222222-7409	NETWORK-SN7409N		
0040A					U6		
0041	00001.000	EA		0222222-7474	NETWORK SN7474N	-SN7474N	
0041A					U5		
0042	00001.000	EA		0222222-7121	NETWORK SN74121N		
0042A					U2		
0043	00001.000	EA		0972663-0001	NETWORK, LM339N		
0043A					AR2		
0044	00001.000	EA		0222225-2311	NETWORK LM311N, SN72311P	SEE - TI DRAWING	
DRAFTSMAN		DATE	CKD. DRAFTSMAN	DATE	DESIGN ENGINEER	DATE	TITLE
							CARD ASSY, PWB, +5V MAIN REG & CONTROL
APPD.-MFG.		DATE	APPD. PROJECT ENGINEER	DATE	RELEASED	DATE	PROJECT NO.
						PART NUMBER	REV
						LM 0943689-0001	h

T.I. 13849



942773-9703



TEXAS INSTRUMENTS
INCORPORATED

DATE 12/22/77

LIST OF MATERIAL

PAGE 4 of

PART NUMBER REV
LM 0943689-0001 W

PRINT ITEM NUMBER	QUANTITY PER ASSEMBLY	UNIT OF ISSUE	DWG. SIZE	PART NUMBER	DESCRIPTION	VENDOR PART NUMBER	
0044A					AR1		
0047	00002.000	EA		0411100-0074	LOCKWASHER 1/4 INTERNAL TOOTH CRES	QPL - MS35333-74	
0048	00002.000	EA		0411010-0003	NUT, JAM, HEXAGCN	QPL - AN316-C4R	
0049	00011.000	EA		0972932-0001	DIODE, 1N914B SWITCHING 75V PIV 75MA 4NS	TI - 1N914B	
0049A					CR3 CR4 CR5 CR13 CR14 CR27		
0049B					CR6 CR7 CR9 CR10 CR15		
0050	00002.000	EA		0418247-0033	CAP 15.00 MF 35V 10% SIZE C	MIL -CS138F156K	
0050A					C1 C5		
0051	00002.000	EA		0972929-0394	CAP FIX CERAMIC 680 PF 10 % 200 V	QPL -M39014/01-1394	
0051A					C9 C10		
0052	00001.000	EA		0539370-0501	RES FIX FILM 16.2K OHM 1% .25 WATT	QOR - NA55	
0052A					R67		
0053	00001.000	EA		0972965-0016	CAP FIX CERAMIC .022 MF 10% 100V	QPL - CK06BX223K	
0053A					C22		
0054	00004.000	EA		0532736-0002	CAP FIX CERAMIC .02 MF 20/80% 25 VOLT	QRL - 2DDU60E203ZAC	
0054A					C3 C7 C23 C39		
0055	00001.000	EA		0972965-0020	CAP FIX CERAMIC .047 MF 10% 100V	QPL - CK06BX473K	
0055A					C21		
0056	00002.000	EA		0419058-0001	CAPACITOR .033 MF 50V 20%	QRL -UK50-333	
0056A					C14 C16		
DRAFTSMAN		DATE	CKD DRAFTSMAN	DATE	DESIGN ENGINEER	DATE	TITLE
							CARD ASSY, PWB, +5V MAIN REG & CNTRL
APPD. MFG.		DATE	APPD. PROJECT ENGINEER	DATE	RELEASED	DATE	PROJECT NO.
						PART NUMBER REV	
						LM 0943689-0001	W

T.I. 13849

Change 1

6-40

Digital Systems Division

942773-9703

Change 1

6-4 1

Digital Systems Division



TEXAS INSTRUMENTS
INCORPORATED

DATE 12/22/77

LIST OF MATERIAL

PAGE 5 of

PART NUMBER
LM 0943685-0001 REV
w

PRINT ITEM NUMBER	QUANTITY PER ASSEMBLY	UNIT OF ISSUE	DWG SIZE	PART NUMBER	DESCRIPTION	VENDOR PART NUMBER		
0057	00006.000	EA		0534348-0001	CAP FIX CERAMIC .10 MF 20/80 & 10V	CRL - UK10-104		
0057A					C19 C20 C26 C27 C37 C38			
0059	00005.000	EA		0972924-0021	CAP FIX TANT SOLID 1.0 MFD 10 % 50 VOLT QPL	-M39003/1-2356		
0059A					C4 C8 C17 C18 C25			
0060	00002.000	EA		0972924-0019	CAP FIX TANT SOLID 22 MFD 10 % 35 VOLT QPL	-M39003/1-2306		
0060A					C2 C33			
0061	00001.000	EA		0972924-0011	CAP FIX TANT SOLID 68 MFD 10 % 15 VOLT QPL	-M39003/1-2274		
0061A					C11			
0062	00004.000	EA		0230895-1000	CAP 100.0 MF 50V	SPR -390-107-6050		
0062A					C13 C15 C34 C35			
0063	00002.000	EA		0972946-0096	RES FIX 20 K OHM 5 % .25 W CARBON FILM	RJH - R-25		
0063A					R18 R47			
0064	00001.000	EA		0972946-0040	RES FIX 91.0 OHM 5 % .25 W CARBON FILM	RJH - R-25		
0064A					R17			
0065	00001.000	EA		0972946-0066	RES FIX 1.1K OHM 5% .25 W CARBON FILM	RJH - R-25		
0065A					R1			
0067	00002.000	EA		0972947-0009	RES FIX 4.7 OHM 5 % .5 W CARBON FILM	RJH - R-50		
0067A					R36 R39			
0069	00005.000	EA		0972946-0027	RES FIX 27.0 OHM 5 % .25 W CARBON FILM	RJH - R-25		
0069A					R32 R37 R38 R33 R61			
DRAFTSMAN		DATE	CKD. DRAFTSMAN	DATE	DESIGN ENGINEER	DATE	TITLE	
							CARD ASSY, PWB, +5V MAIN REG & CNTRL	
APPD. MFG		DATE	APPD. PROJECT ENGINEER	DATE	RELEASED	DATE	PROJECT NO.	
							PART NUMBER	REV
							LM 0943685-0001	w

T.I. 13849



942773-9703



TEXAS INSTRUMENTS
INCORPORATED

DATE 12/22/77

LIST OF MATERIAL

PAGE 6 of

PART NUMBER
LM 0943689-0001 REV W

PRINT ITEM NUMBER	QUANTITY PER ASSEMBLY	UNIT OF ISSUE	DWG. SIZE	PART NUMBER	DESCRIPTION	VENDOR PART NUMBER	
0070	00002.000	EA		0539370-0222	RES FIX FILM 20.0 OHMS .25W 1%	COR --NA55	
0070A					R57 R58		
0071	00002.000	EA		0972946-0034	RES FIX 51.0 OHM 5 % .25 W.CARBON FILM	ROH - R-25	
0071A					R48 R60		
0072	00002.000	EA		0972947-0041	RES FIX 100 OHM 5% .5 W CARBON FILM	ROH - R-50	
0072A					R12 R69		
0073	00002.000	EA		0972946-0017	RES FIX 10.0 OHM 5 % .25 W.CARBON FILM	ROH - R-25	
0073A					R19 R42		
0074	00001.000	EA		0972946-0065	RES FIX 1.0K OHM 5% .25 W CARBON FILM	ROH - R-25	
0074A					R15		
0075	00004.000	EA		0972947-0057	RES FIX 470 OHM 5% .5 W CARBON FILM	ROH - R-50	
0075A					K34 R35 R40 R41		
0076	00007.000	EA		0972946-0057	RES FIX 470 OHM 5 % .25 W CARBON FILM	ROH - R-25	
0076A					R27 R28 R31 R71 R54 R55 R62		
0077	00001.000	EA		0972946-0079	RES FIX 3.9K OHM 5 % .25 W CARBON FILM	ROH - R-25	
0077A					R2		
0078	00002.000	EA		0972946-0063	RES FIX 820 OHM 5% .25 W CARBON FILM	ROH - R-25	
0078A					R16 R46		
0079	00002.000	EA		0972978-0075	RES FIX COMP 1.0 W 82 OHMS 5 %	QPL -RC32GB20JS	
0079A					R63 R64		
DRAFTSMAN		DATE	CKD. DRAFTSMAN	DATE	DESIGN ENGINEER	DATE	TITLE
							CARD ASSY, PWB, +5V MAIN REG & CONTRL
APPD -MFG.		DATE	APPD. PROJECT ENGINEER	DATE	RELEASED	DATE	PROJECT NO.
						PART NUMBER	REV
						LM 0943689-0001	W

T.I. 13849

Change 1

6-42

Digital Systems Division

942773-9703



TEXAS INSTRUMENTS
INCORPORATED

DATE 12/22/77

LIST OF MATERIAL

PAGE 7 of

PART NUMBER
LM 0943689-0001 REV W

PRINT ITEM NUMBER	QUANTITY PER ASSEMBLY	UNIT OF ISSUE	DWG. SIZE	PART NUMBER	DESCRIPTION	VENDOR PART NUMBER	
0080	00001.000	EA		0972946-0067	RES FIX 1.2K OHM 5% .25 W CARBON FILM	ROH - R-25	
0080A					R4		
0081	00001.000	EA		0539370-0408	RES FIX FILM 1.74K OHM 1% .25 WATT	COR - NA55	
0081A					R11		
0082	00005.000	EA		0972946-0073	RES FIX 2.2K OHM 5% .25 W CARBON FILM	ROH - R-25	
0082A					R14 R49 R24 R51 R74		
0084	00002.000	EA		0539370-0440	RES FIX FILM 4.32K OHM 1% .25 WATT	COR - NA55	
0084A					R43 R65		
0085	00009.000	EA		0972946-0081	RES FIX 4.7K OHM 5% .25 W CARBON FILM	ROH - R-25	
0085A					R8 R10 R56 R20 R72 R76 R78		
0085B					R79 R80		
0086	00005.000	EA		0972946-0089	RES FIX 10K OHM 5% .25 W CARBON FILM	ROH - R-25	
0086A					R3 R5 R6 R50 R75		
0087	00004.000	EA		0972946-0082	RES FIX 5.1K OHM 5% .25 W CARBON FILM	ROH - R-25	
0087A					R13 R52 R82 R83		
0089	00002.000	EA		0972946-0095	RES FIX 18K OHM 5% .25 W CARBON FILM	ROH - R-25	
0089A					R29 R30		
0090	00002.000	EA		0972946-0107	RES FIX 56 K OHM 5% .25 W CARBON FILM	ROH - R-25	
0090A					R7 R9		
0091	00001.000	EA		0972946-0111	RES FIX 82 K OHM 5% .25 W CARBON FILM	ROH - R-25	
DRAFTSMAN		DATE	CKD. DRAFTSMAN	DATE	DESIGN ENGINEER	DATE	TITLE
							CARD ASSY, PWB, +5V MAIN REG & CTRL
APPD. MFG.		DATE	APPD. PROJECT ENGINEER	DATE	RELEASED	DATE	PROJECT NO.
						PART NUMBER	REV
						LM 0943689-0001	W

T.I. 13849

Change 1

6-43

Digital Systems Division



942773-9703

Change 1

6-44

Digital Systems Division



TEXAS INSTRUMENTS
INCORPORATED

DATE 12/22/77

LIST OF MATERIAL

PAGE 8 of

PART NUMBER
LM 0943685-0001 REV **W**

PRINT ITEM NUMBER	QUANTITY PER ASSEMBLY	UNIT OF ISSUE	DWG. SIZE	PART NUMBER	DESCRIPTION	VENDOR PART NUMBER	
0091A					R53		
0093	00001.000	EA		0972946-0097	RES FIX 22 K OHM 5 % .25 W CARBON FILM	ROH - R-25	
0093A					R73		
0094	00001.000	EA		0232163-0000	JACK PRNTD CKT TIP HORIZONTAL 5 AMP RED	JUN -105-752	
0094A					TP1		
0096	00004.000	EA		0972988-0014	SCREW 4-40 X .312 PAN HEAD CRES		
0097	00002.000	EA		0235788-0050	TERMINAL LUG SOLDER STD.H .250X.020	ZIE -334	
0098	00004.000	EA		0411101-0058	LOCKWASHER #6 EXTERNAL TOOTH CRES	QPL - MS35335-58	
0101	00002.000	EA		0230543-3000	CAP. .0100 MF 100V + 80.-20%	ERI - 805-00025VU-1	
0101A					C24 C29		
0102	00002.000	EA		0539370-0546	RES FIX FILM 47.5K OHM 1% .25 WATT	COR - NA55	
0102A					R44 R45		
0104	AK	FT		0411400-0018	WIRE, BARE TINNED, 18AWG, COPPER BUS	TWP -18-630	
0106	00001.000	EA		0418356-2261	CAP FIX 100 MF 10V 10% TANTALUM SOLID	QPL -M39003/1-2261	
0106A					C6		
0107	00001.000	EA		0539370-0493	RES FIX FILM 13.3K OHM 1% .25 WATT	COR -NA55D-1G0PPM/C	
0107A					R68		
0111	00002.000	EA		0966547-0001	EXTRUSION, INSULATOR-HEAT SINK		
0112	AR	EA		0417630-0001	ADHESIVE, EPOXY 0151	HYS -EPGX1-PATCH KI	
0113	00001.000	EA		0972946-0041	RES FIX 100 OHM 5 % .25 W CARBON FILM	ROH - R-25	
DRAFTSMAN		DATE	CKD. DRAFTSMAN	DATE	DESIGN ENGINEER	DATE	TITLE
							CARD ASSY, PWB, +5V MAIN REG & CONTROL
APPD. MFG		DATE	APPD. PROJECT ENGINEER	DATE	RELEASED	DATE	PROJECT NO.
						PART NUMBER	REV
						LM 0943685-0001	W

T.I. 13849



942773-9703

Change 1

6-45/6-46

Digital Systems Division



TEXAS INSTRUMENTS
INCORPORATED

DATE 12/22/77

LIST OF MATERIAL

PAGE 9 of

PART NUMBER	REV
LM 0943689-0001	W

PRINT ITEM NUMBER	QUANTITY PER ASSEMBLY	UNIT OF ISSUE	DWG. SIZE	PART NUMBER	DESCRIPTION	VENDOR PART NUMBER	
0113A					R66		
0114	00001.000	EA		0972948-0001	TRANSISTOR, NPN, GEN. PURP. SW TO-5	TI - 2N2219A	
0114A					Q19		
0116	00001.000	EA		0539370-0426	RES FIX FILM 2.67K OHM 1% .25 WATT	CGR - NA55	
0116A					R70		
0117	00001.000	EA		0972946-0051	RES FIX 270 OHM 5% .25 W CARBON FILM	RQH - R-25	
0117A					R21		
0119	00002.000	EA		0972946-0075	RES FIX 2.7K OHM 5% .25 W CARBON FILM	RQH - R-25	
0119A					K22 R59		
0120	00001.000	EA		0972946-0055	RES FIX 390 OHM 5% .25 W CARBON FILM	RQH - R-25	
0120A					R23		
0123	00001.000	EA		0539370-0435	RES FIX FILM 3.32K OHM 1% .25 WATT	CGR - NA55	
0123A					R77		
0125	REF	EA		0943710-9901	UNIT TEST PROCEDURE, +5 MAIN ASSY		
0126	AR	EA		0417486-0004	COMPOUND SILICON RTV TRANSLUCENT	CGR - 3144	
0127	AR	FT		0411634-0300	SLEEVE, PVC, .034 DIA. BLACK	QPL - MIL-1-631	
0128	AK	FT		0417177-0004	INSUL SLVG, .125 ID ELEC-HT SHRINKABLE	SEE - DRAWING	
0129	00002.000	EA		0996521-0014	INSULATOR GRAY .009 THERMALLY COND	055285-7403-C5FR-25	
DRAFTSMAN		DATE	CKD. DRAFTSMAN	DATE	DESIGN ENGINEER	DATE	TITLE
							CARD ASSY, PWB, +5V MAIN REG & CNTRL
APPD. MFG		DATE	APPD. PROJECT ENGINEER	DATE	RELEASED	DATE	PROJECT NO.
						PART NUMBER	REV
						LM 0943689-0001	W

TI 13849



942773-9703

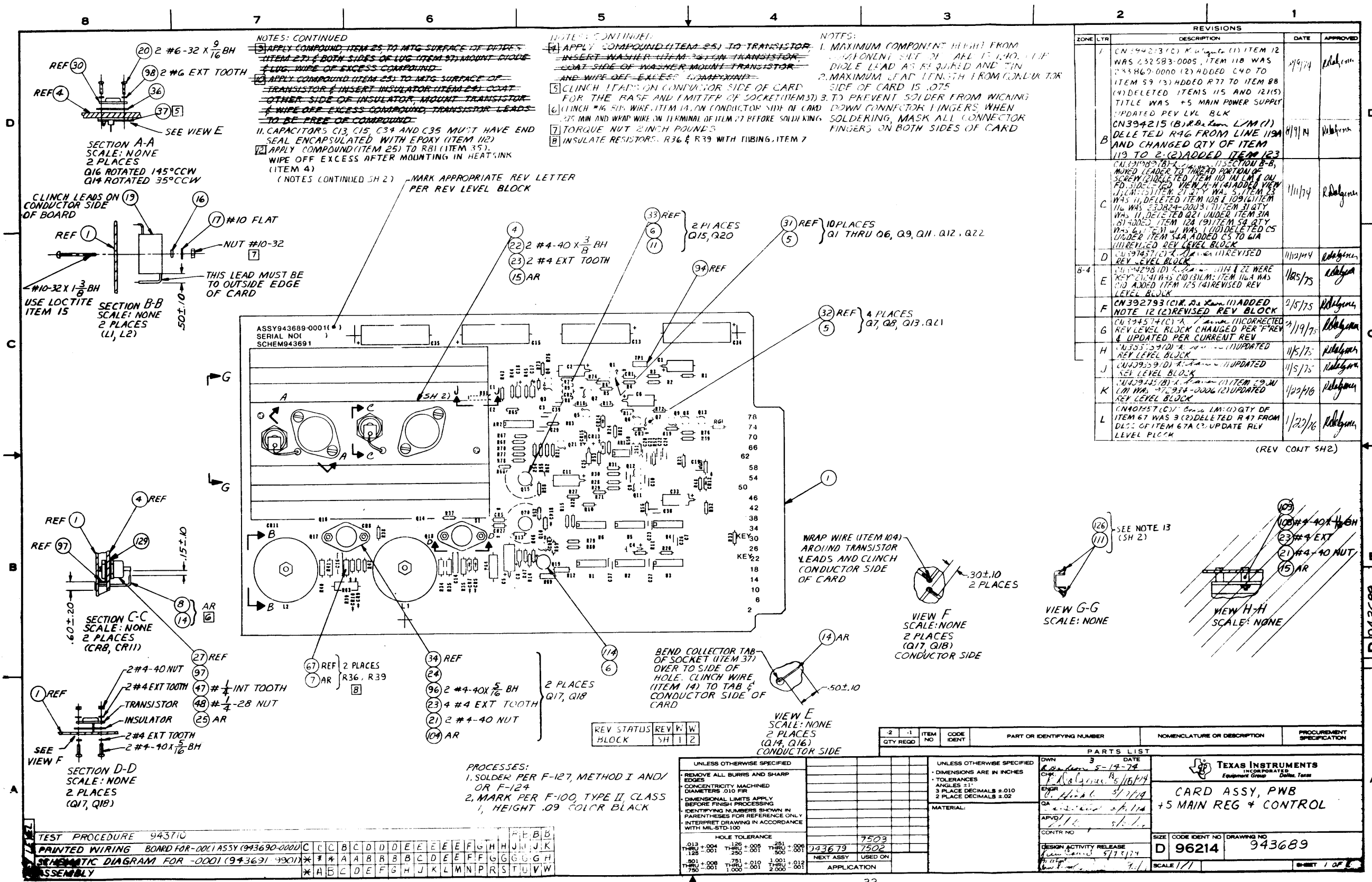

ZONE		REVISIONS		DATE	APPROVED
TR		DESCRIPTION			
	A	CN 394213 (C) K. R. L. (1) ITEM 12 WAS 232583-0005, ITEM 118 WAS 233869-0000 (2) ADDED C40 TO ITEM 59 (3) ADDED R77 TO ITEM 88 (4) DELETED ITEMS 115 AND 121 (5) TITLE WAS +5 MAIN POWER SUPPLY (UPDATED REV LVL BLK CN394215 (B) R. R. L. L/M (1) DELETED R46 FROM LINE 119A AND CHANGED QTY OF ITEM 119 TO 2 (2) ADDED ITEM 123		1/9/74	R. Holgren
	B	ADDED SECTION B-B, MOUNT LEADERS TO THREADED PORTION OF SCREEN (DELETED ITEM 110 IN L/M) ON FD. SIDE (DELETED VIEW H-H) ADDED VIEW J, L, M (5) ITEM 21 QTY WAS 5, ITEM 23 WAS 11, DELETED ITEM 108, 109 (6) ITEM 116 WAS 233869-0003 (7) ITEM 31 QTY WAS 11, DELETED Q21 UNDER ITEM 31A (8) ADDED ITEM 124 (9) ITEM 54 QTY WAS 6, ITEM 51 WAS 1 (10) DELETED C5 UNDER ITEM 34A, ADDED C5 TO 61A (UNREVISED REV LEVEL BLOCK		11/11/74	R. Holgren
	C	ADDED SECTION B-B, MOUNT LEADERS TO THREADED PORTION OF SCREEN (DELETED ITEM 110 IN L/M) ON FD. SIDE (DELETED VIEW H-H) ADDED VIEW J, L, M (5) ITEM 21 QTY WAS 5, ITEM 23 WAS 11, DELETED ITEM 108, 109 (6) ITEM 116 WAS 233869-0003 (7) ITEM 31 QTY WAS 11, DELETED Q21 UNDER ITEM 31A (8) ADDED ITEM 124 (9) ITEM 54 QTY WAS 6, ITEM 51 WAS 1 (10) DELETED C5 UNDER ITEM 34A, ADDED C5 TO 61A (UNREVISED REV LEVEL BLOCK		11/12/74	R. Holgren
	D	REV LEVEL BLOCK		11/21/74	R. Holgren
	E	CN 392798 (D) K. R. L. (1) 22 WERE KEPT, 21 WERE 20 (3) L/M: ITEM 114 WAS 110 ADDED ITEM 125 (4) REVISED REV LEVEL BLOCK		1/8/75	R. Holgren
	F	CN 392793 (C) K. R. L. (1) ADDED NOTE 12 (2) REVISED REV BLOCK		2/5/75	R. Holgren
	G	CN 394574 (C) K. R. L. (1) INCORRECTED REV LEVEL BLOCK CHANGED PER F REV & UPDATED PER CURRENT REV		2/19/75	R. Holgren
	H	CN 394574 (C) K. R. L. (1) REVISED REV LEVEL BLOCK		11/5/75	R. Holgren
	J	CN 409359 (D) K. R. L. (1) REVISED REV LEVEL BLOCK		11/5/75	R. Holgren
	K	CN 409359 (D) K. R. L. (1) REVISED REV LEVEL BLOCK		1/22/76	R. Holgren
	L	CN 409359 (D) K. R. L. (1) QTY OF ITEM 67 WAS 3 (2) DELETED R 47 FROM DLS: OF ITEM 67A (3) UPDATE REV LEVEL BLOCK		1/22/76	R. Holgren

D 943689

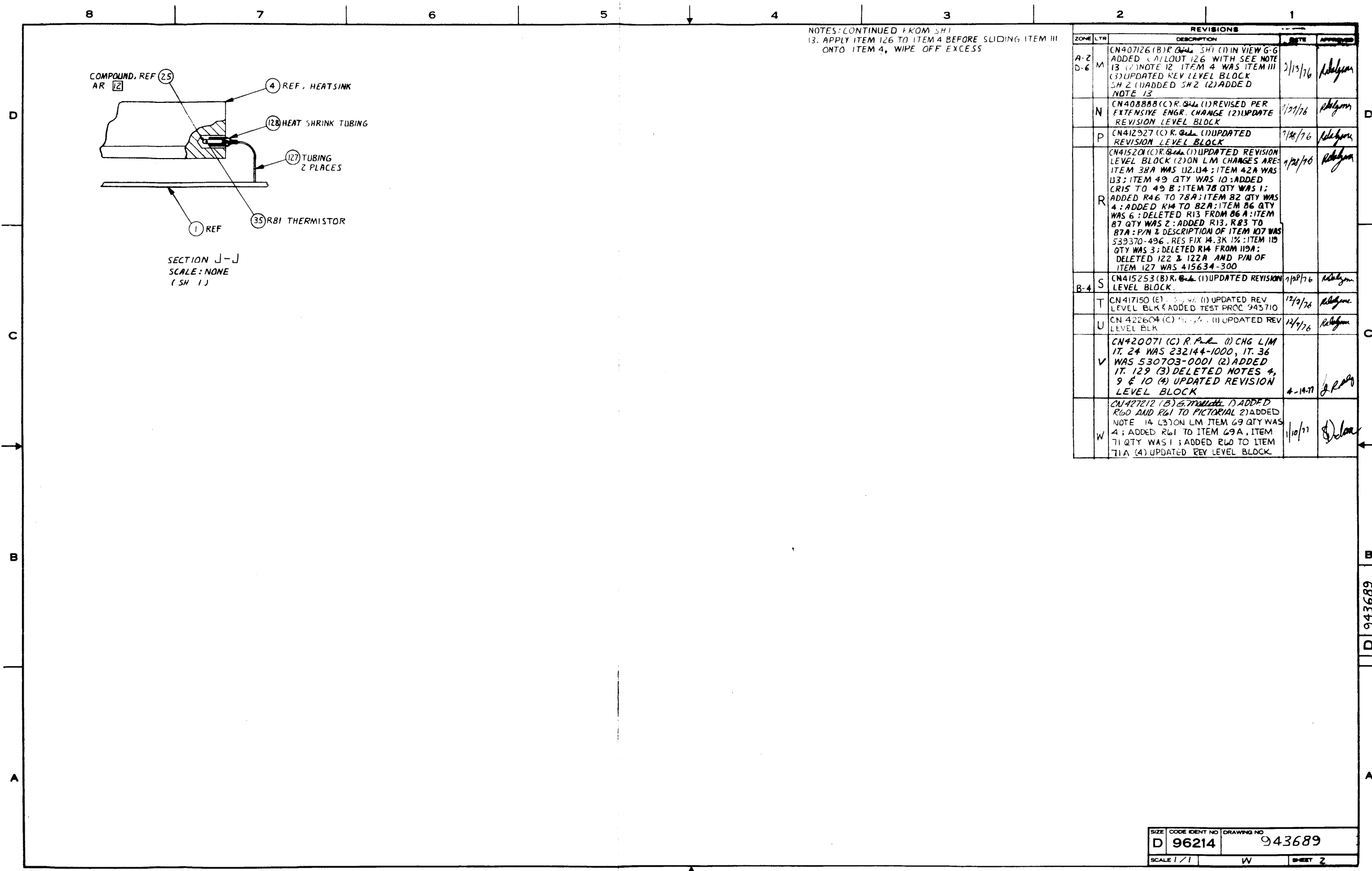

D 943689

SIZE	CODE IDENT NO	DRAWING NO
D	96214	943689
SCALE 1/1	W	SHEET 2

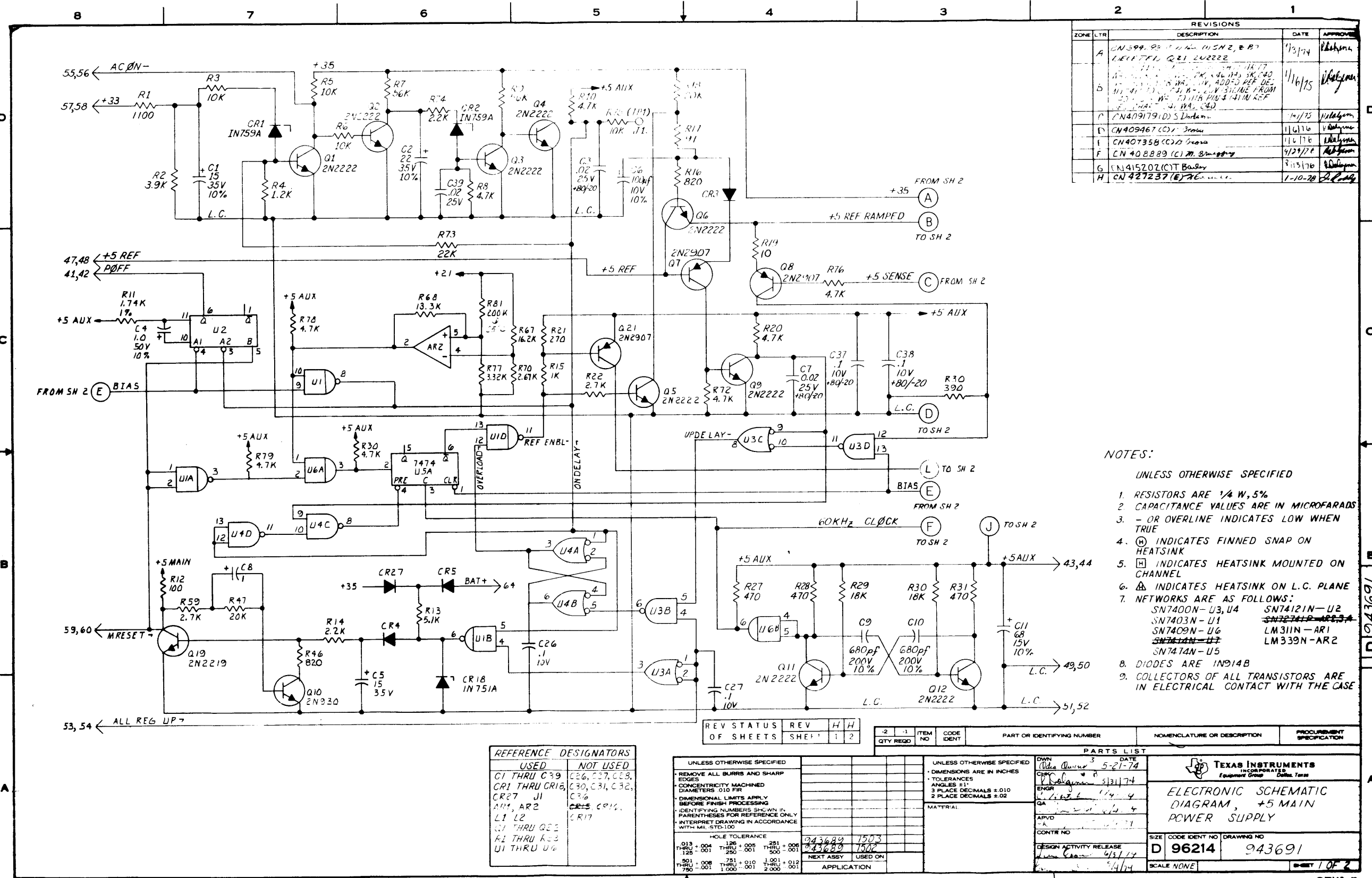

REVISIONS				
ZONE	LTR	DESCRIPTION	DATE	APPROVED
	A	EN 399.95 (1) SH 2, B B	11/17/74	W. H. H.
	B	EN 399.95 (1) SH 2, B B	11/17/74	W. H. H.
	C	EN 409179 (D) S. D. D.	11/17/74	W. H. H.
	D	EN 409467 (C) S. D. D.	11/17/74	W. H. H.
	E	EN 407358 (C) S. D. D.	11/17/74	W. H. H.
	F	EN 408889 (C) M. B. M.	4/29/75	W. H. H.
	G	EN 415202 (C) T. B. T.	3/15/76	W. H. H.
	H	EN 427237 (E) T. B. T.	1-10-78	W. H. H.

- NOTES:
- UNLESS OTHERWISE SPECIFIED
 - RESISTORS ARE 1/4 W, 5%
 - CAPACITANCE VALUES ARE IN MICROFARADS
 - OR OVERLINE INDICATES LOW WHEN TRUE
 - (A) INDICATES FINNED SNAP ON HEATSINK
 - (H) INDICATES HEATSINK MOUNTED ON CHANNEL
 - (B) INDICATES HEATSINK ON L.C. PLANE
 - NETWORKS ARE AS FOLLOWS:
 SN7400N - U3, U4
 SN7403N - U1
 SN7409N - U6
 SN7414N - U7
 SN7474N - U5
 - DIODES ARE IN914B
 - COLLECTORS OF ALL TRANSISTORS ARE IN ELECTRICAL CONTACT WITH THE CASE

REFERENCE DESIGNATORS	
USED	NOT USED
C1 THRU C39	C26, C27, C28, C30, C31, C32, C36
CR1 THRU CR18	CR15, CR16, CR17
Q1 THRU Q12	
R1 THRU R100	
U1 THRU U6	

REV	STATUS	REV	H	H	QTY	REQD	ITEM NO	CODE IDENT	PART OR IDENTIFYING NUMBER	NOMENCLATURE OR DESCRIPTION	PROCUREMENT SPECIFICATION
1	REVISED	1	1	2							

UNLESS OTHERWISE SPECIFIED		UNLESS OTHERWISE SPECIFIED	
REMOVE ALL BURRS AND SHARP EDGES	CONCENTRICITY MACHINED	DIMENSIONS ARE IN INCHES	TOLERANCES
DIMENSIONAL LIMITS APPLY BEFORE FINISH PROCESSING	IDENTIFYING NUMBERS SHOWN IN PARENTHESES FOR REFERENCE ONLY	ANGLES ±1°	3 PLACE DECIMALS ±.010
INTERPRET DRAWING IN ACCORDANCE WITH MIL-STD-100		2 PLACE DECIMALS ±.02	
HOLE TOLERANCE		MATERIAL	
.013 + .004 THRU .001	.126 + .005 THRU .001		
.251 + .006 THRU .001	.500 + .001 THRU .001		
.501 + .008 THRU .001	.751 + .010 THRU .001		
.751 + .010 THRU .001	1.001 + .012 THRU .001		
	2.000 + .001 THRU .001		

PARTS LIST		DATE	
OWN	5-21-74	DATE	5-21-74
ENGR	5/31/74	DATE	5/31/74
CA	5/31/74	DATE	5/31/74
APVD	5/31/74	DATE	5/31/74
CONTR NO		DATE	
DESIGN ACTIVITY RELEASE	4/11/74	DATE	4/11/74
APPROVED	4/11/74	DATE	4/11/74

SIZE	CODE IDENT NO	DRAWING NO
D	96214	943691

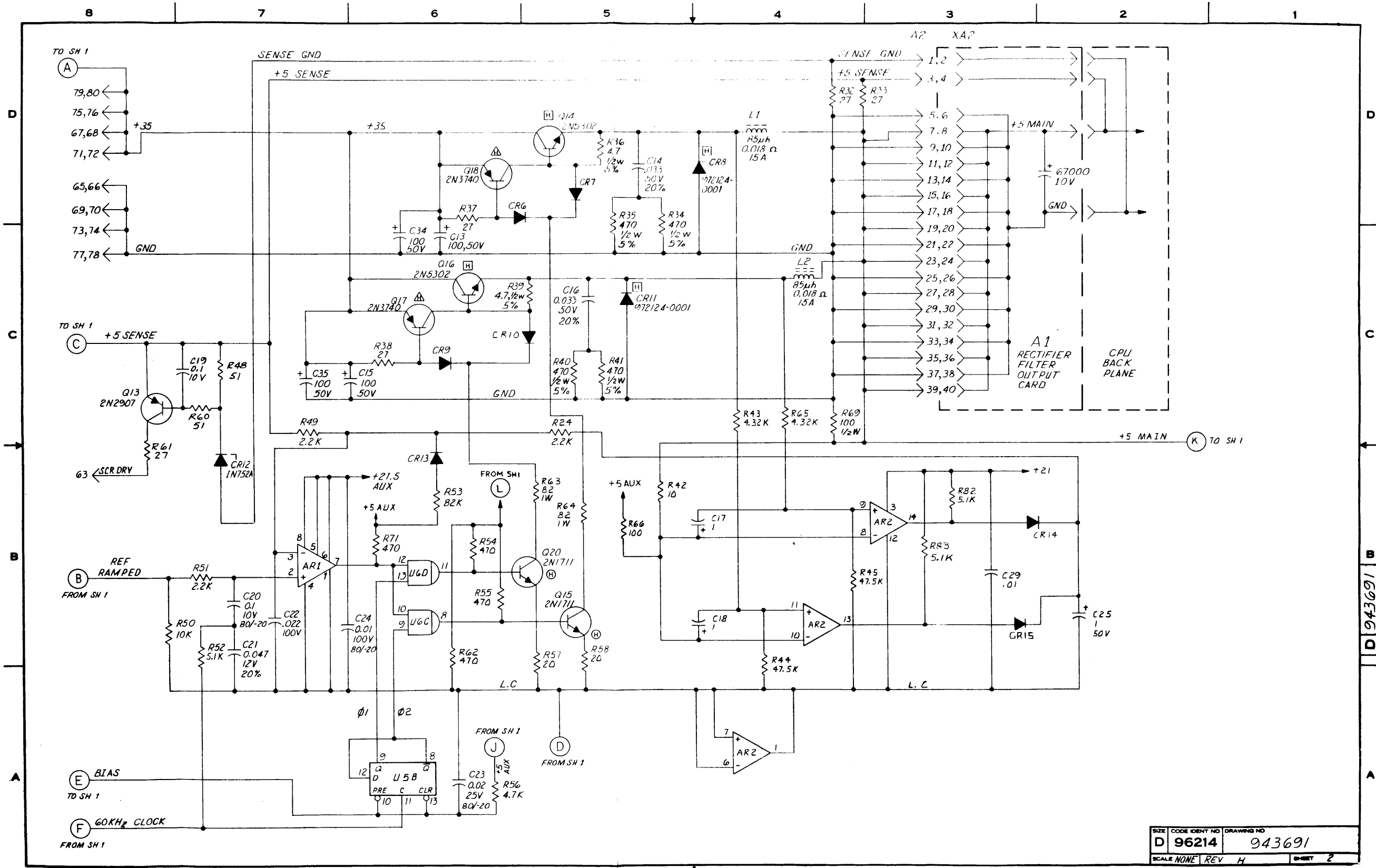

SIZE	CODE	IDENT NO	DRAWING NO
D	96214		943691
SCALE	NONE	REV	H
			SHEET 2

Change 1

6-5 1

Digital Systems Division



TEXAS INSTRUMENTS
INCORPORATED

DATE 09/22/77

LIST OF MATERIAL

PAGE 1 of

PART NUMBER
LM 0943652-0001 REV
AR

PRINT ITEM NUMBER	QUANTITY PER ASSEMBLY	UNIT OF ISSUE	DWG. SIZE	PART NUMBER	DESCRIPTION	VENDOR PART NUMBER	
0002	00015.000	EA		0185113-0001	X SPACER XST TO-18 CASE	* -	
0003	00007.000	EA		0184262-0001	PAD, MOUNTING, TO-5, 4 LEAD, RED	THR - 7717-5	
0004	00005.000	EA		0419368-0002	HEATSINK, TRANSISTOR	WAK - NF-207	
0005	00002.000	EA		0232144-1000	INSULATOR WASHER XST TO-66	TI - #10-21-023-022	
0006	00001.000	EA		0222224-2741	NETWORK SN72741P OPERATIONAL AMP	-SN72741P	
00064					AR2		
0007	00002.000	EA		0972546-0002	TRIAC, SILICON-12A TIC126A		
0007A					CR30 CR33		
0008	00005.000	EA		0972958-0001	TRANSISTOR, PNP, GEN. PURP. SW TO-5	TI - 2N2905A	
00084					Q2, Q8, Q17, Q18, Q24		
0009	00004.000	EA		0418600-0002	TRANSISTOR, 2N2605	WPL - 2N2605	
00094					Q21, Q22, Q33, Q38		
0010	00003.000	EA		0972959-0001	TRANSISTOR, 2N3055 NPN 70V 115M TO-3	TI - 2N3055	
0010A					Q3, Q7, Q11		
0011	00007.000	EA		0800523-0001	TRANSISTOR A5T2907 PNP SILICON	TI - A5T2907	
00114					Q1, Q6, Q26, Q27, Q29, Q30, Q44		
0012	00008.000	EA		0972957-0001	TRANSISTOR, 2N930A NPN LOW CUR AMP, TO-18	MOT - 2N930A	
00124					Q9, Q10, Q32, Q34, Q40, Q42, Q39,		
00129					Q45		
0013	00008.000	EA		0972057-0001	TRANSISTOR-A5T2222 NPN SILICON	TI - A5T2222	
DRAFTSMAN		DATE	CKD. DRAFTSMAN	DATE	DESIGN ENGINEER	DATE	TITLE
			<i>[Signature]</i>	9-23-77			CARD ASSY, MEM AUX & REF REG
APPD. MFG		DATE	APPD. PROJECT ENGINEER	DATE	RELEASED	DATE	PROJECT NO.
							7500
						PART NUMBER	REV
						LM 0943692-0001	AR

TI 13849



942773-9703

Change 1

6-52

Digital Systems Division



TEXAS INSTRUMENTS
INCORPORATED

DATE 09/22/77

LIST OF MATERIAL

PAGE 2 of .

PART NUMBER	REV
LM J943692-0001	AR

PRINT ITEM NUMBER	QUANTITY PER ASSEMBLY	UNIT OF ISSUE	DWG. SIZE	PART NUMBER	DESCRIPTION	VENDOR PART NUMBER	
0013A					Q4 Q5 Q19 Q28 Q31 Q36 Q37		
0013B					Q41		
0014	00002.000	EA		0236091-0015	XST- 2N3740	MOT -2N3740	
0014A					Q12,Q15		
0015	00001.000	EA		0972934-0008	DIODE,1N753A 6.2 V 5% SIL VOLT REG	QPL - 1N753A	
0015A					CR3		
0016	00001.000	EA		0972934-0006	DIODE,1N751A 5.1 V 5% SIL VOLT REG	QPL - 1N751A	
0016A					CR1		
0017	00002.000	EA		0972934-0007	DIODE,1N752A 5.6 V 5% SIL VOLT REG	QPL - 1N752A	
0017A					CR19,CR32		
0018	00002.000	EA		0972934-0014	DIODE,1N759A 12.0 V 5% SIL VOLT REG	QPL - 1N759A	
0018A					CR39,CR40		
0019	00003.000	EA		0972164-0001	DIODE,MR501		
0019A					CR9,CR28,CR29		
0020	00017.000	EA		0972932-0001	DIODE,1N914B SWITCHING 75V PIV 75MA 4NS	TI - 1N914B	
0020A					CR22 THRU CR25,CR31,CR41		
0020B					CR15,CR18,CR20,CR21,CR42		
0020C					CR2,CR7,CR10,CR12,CR13,CR14		
0021	00001.000	EA		0532736-0002	CAP FIX CERAMIC .02 MF 20/80% 25 VOLT	CRL - 200060E203ZAC	
0021A					C19		
DRAFTSMAN		DATE	CKD. DRAFTSMAN	DATE	DESIGN ENGINEER	DATE	TITLE
APPD. MFG.		DATE	APPD. PROJECT ENGINEER	DATE	RELEASED	DATE	PROJECT NO.
							CARD ASSY, MEM AUX & REF REG
						PART NUMBER	REV
						LM J943692-0001	AR

T.I. 13849



942773-9703

Change 1

6-53

Digital Systems Division



TEXAS INSTRUMENTS
INCORPORATED

DATE 09/22/77

LIST OF MATERIAL

PAGE 3 of

PART NUMBER
LM 0943692-0001 REV
AR

PRINT ITEM NUMBER	QUANTITY PER ASSEMBLY	UNIT OF ISSUE	DWG. SIZE	PART NUMBER	DESCRIPTION	VENDOR PART NUMBER	
0022	00010.000	EA		0534348-0001	CAP FIX CERAMIC .10 MF 2078J % 10V	CKL - UK10-104	
0022A					C2,C18,C22,C35,C36		
0022B					C13,C17,C20,C21,C30		
0023	00002.000	EA		0233096-0001	RES 1.0000 OHM .5 W 5.	AB -EB10G5	
0023A					R8 R9		
0024	00002.000	EA		0972946-0017	RES FIX 10.0 OHM 5 % .25 W CARBON FILM	ROH - R-25	
0024A					R5,R18		
0025	00001.000	EA		0233133-0001	RES 2.0000 OHM .5 W 5.	AB -EB20G5	
0025A					R1		
0026	00003.000	EA		0972946-0041	RES FIX 100 OHM 5 % .25 W CARBON FILM	ROH - R-25	
0026A					R15,R64,R100		
0027	00003.000	EA		0972946-0045	RES FIX 150 OHM 5 % .25 W CARBON FILM	ROH - R-25	
0027A					R25,R48,R87		
0029	00004.000	EA		0972947-0053	RES FIX 330 OHM 5% .5 W CARBON FILM	ROH - R-50	
0029A					R35 THRU R38		
0030	00004.000	EA		0972946-0061	RES FIX 680 OHM 5 % .25 W CARBON FILM	ROH - R-25	
0030A					R40,R41,R51,R7		
0031	00002.000	EA		0972946-0063	RES FIX 820 OHM 5% .25 W CARBON FILM	ROH - R-25	
0031A					R11,R89		
0032	00001.000	EA		0418161-0003	DIODE REFERENCE,6.2V 5% TEMP COMP	QPL - IN827JAN	
DRAFTSMAN		DATE	CKD. DRAFTSMAN	DATE	DESIGN ENGINEER	DATE	TITLE
							CARD ASSY, MEM AUX & REF REG
APPD.-MFG.		DATE	APPD. PROJECT ENGINEER	DATE	RELEASED	DATE	PROJECT NO.
						PART NUMBER	REV
						LM 0943692-0001	AR

T.I. 13849



942773-9703

Change 1

6-54

Digital Systems Division



TEXAS INSTRUMENTS
INCORPORATED

DATE 09/22/77

LIST OF MATERIAL

PAGE 4 of

PART NUMBER
LM 0943692-0001 REV
AR

PRINT ITEM NUMBER	QUANTITY PER ASSEMBLY	UNIT OF ISSUE	DWG. SIZE	PART NUMBER	DESCRIPTION	VENDOR PART NUMBER	
0032A					CR8		
0033	00004.000	EA		0972946-0065	RES FIX 1.0K OHM 5% .25 W CARBON FILM	ROH - R-25	
0033A					R2,R10,R31,R39		
0034	00002.000	EA		0539370-0412	RES FIX FILM 1.91K OHM 1% .25 WATT	COR - NA55	
0034A					R17,R70		
0035	00001.000	EA		0972946-0069	RES FIX 1.5K OHM 5% .25 W CARBON FILM	ROH - R-25	
0035A					R6		
0036	00002.000	EA		0539370-0416	RES FIX FILM 2.10K OHM 1% .25 WATT	COR - NA55	
0036A					K27,R71		
0037	00001.000	EA		0972946-0073	RES FIX 2.2K OHM 5% .25 W CARBON FILM	ROH - R-25	
0037A					R12		
0038	00003.000	EA		0972946-0077	RES FIX 3.3K OHM 5% .25 W CARBON FILM	ROH - R-25	
0038A					R19,R73,R82		
0039	00002.000	EA		0539370-0437	RES FIX FILM 3.48K OHM 1% .25 WATT	COR -NA55D-100PPM/C	
0039A					R30,R58		
0040	00003.000	EA		0972946-0081	RES FIX 4.7K OHM 5% .25 W CARBON FILM	ROH - R-25	
0040A					R55,R62,R81		
0041	00001.000	EA		0539370-0463	RES FIX FILM 6.49K OHM 1% .25 WATT	COR - NA55	
0041A					R26		
0042	00004.000	EA		0972946-0072	RES FIX 2.0K OHM 5% .25 W CARBON FILM	ROH - R-25	
DRAFTSMAN		DATE	CKD. DRAFTSMAN	DATE	DESIGN ENGINEER	DATE	TITLE
							CARD ASSY, MEM AUX & REF REG
APPD -MFG.		DATE	APPD. PROJECT ENGINEER	DATE	RELEASED	DATE	PROJECT NO.
						PART NUMBER	REV
						LM 0943692-0001	AR

T.I. 13849



942773-9703

Change 1

6-55

Digital Systems Division



TEXAS INSTRUMENTS
INCORPORATED

DATE 09/22/77

LIST OF MATERIAL

PAGE 3 of

PART NUMBER
LM 0943692-0001 REV
AR

PRINT ITEM NUMBER	QUANTITY PER ASSEMBLY	UNIT OF ISSUE	DWG. SIZE	PART NUMBER	DESCRIPTION	VENDOR PART NUMBER			
0042					R61,R103,R104,R28				
0043	00006.000	EA		0972946-0089	RES FIX 10K OHM 5% .25 W CARBON FILM	ROH - R-25			
0043A					R43,R54,R85,R80,R84,R88,				
0045	00001.000	EA		0972573-0001	TRANSISTOR,TIP125 PNP SILICON DARLINGTON	T1- -TIP 125			
0045A					Q43				
0046	00004.000	EA		0972946-0113	RES FIX 100K OHM 5% .25 W CARBON FILM	ROH - R-25			
0046A					R47,R52,R101,R102				
0047	00002.000	EA		0972946-0116	RES FIX 130K OHM 5% .25 W CARBON FILM	ROH - R-25			
0047A					R50,R69				
0048	00002.000	EA		0972946-0102	RES FIX 36 K OHM 5% .25 W CARBON FILM	ROH - R-25			
0048A					R74,R90				
0049	00004.000	EA		0972946-0122	RES FIX 240K OHM 5% .25 W CARBON FILM	ROH - R-25			
0049A					R76,R77,R78,R86				
0050	00001.000	EA		0972946-0128	RES FIX 430K OHM 5% .25 W CARBON FILM	ROH - R-25			
0050A					R46				
0051	00002.000	EA		0972946-0093	RES FIX 15K OHM 5% .25 W CARBON FILM	ROH - R-25			
0051A					R67,R72				
0052	00001.000	EA		0972946-0138	RES FIX 1.1M OHM 5% .25 W CARBON FILM	ROH - R-25			
0052A					R49				
0053	00001.000	EA		0972946-0139	RES FIX 1.2M OHM 5% .25 W CARBON FILM	ROH - R-25			
DRAFTSMAN		DATE	CKD. DRAFTSMAN	DATE	DESIGN ENGINEER	DATE	TITLE	CARD ASSY, MEM AUX & REF REG	
APPD. MFG		DATE	APPD. PROJECT ENGINEER	DATE	RELEASED	DATE	PROJECT NO.	PART NUMBER LM 0943692-0001 REV AR	

T.I. 13849



942773-9703



TEXAS INSTRUMENTS
INCORPORATED

DATE 09/22/77

LIST OF MATERIAL

PAGE 6 of

PART NUMBER
LM 0943692-0001 REV
AR

PRINT ITEM NUMBER	QUANTITY PER ASSEMBLY	UNIT OF ISSUE	DWG. SIZE	PART NUMBER	DESCRIPTION	VENDOR PART NUMBER	
0053A					R75		
0054	00001.000	EA		0539370-0462	RES FIX FILM 6.34K OHM 1% .25 WATT	CUR - NA55	
0054A					R16		
0055	00001.000	EA		0972947-0081	RES FIX 4.7K OHM 5% .5 W CARBON FILM	ROH - R-50	
0055A					R3		
0056	00001.000	EA		0972946-0125	RES FIX 330K OHM 5% .25 W CARBON FILM	ROH - R-25	
0056A					R66		
0057	00002.000	EA		0972946-0031	RES FIX 39.0 OHM 5% .25 W CARBON FILM	ROH - R-25	
0057A					R20,R33		
0058	00002.000	EA		0972946-0075	RES FIX 2.7K OHM 5% .25 W CARBON FILM	ROH - R-25	
0058A					R53,R79		
0059	00001.000	EA		0972946-0076	RES FIX 3.0K OHM 5% .25 W CARBON FILM	ROH - R-25	
0059A					R56		
0060	00001.000	EA		0972947-0024	RES FIX 20 OHM 5% .5 W CARBON FILM	ROH - R-50	
0060A					R68		
0062	00002.000	EA		0972947-0013	RES FIX 6.8 OHM 5% .5 W CARBON FILM	ROH - R-50	
0062A					R14,R32		
0064	00001.000	EA		0972942-0005	RES FIX 0.47 OHMS 5% 5 WATT WIREWOUND	RCL - T-5	
0064A					R42		
0065	00001.000	EA		0972942-0003	RES FIX 0.25 OHMS 5% 5 WATT WIREWOUND	IRC - AS-5	
DRAFTSMAN		DATE	CKD. DRAFTSMAN	DATE	DESIGN ENGINEER	DATE	TITLE
							CARD ASSY, MEM AUX & REF REG
APPD. MFG.		DATE	APPD. PROJECT ENGINEER	DATE	RELEASED	DATE	PROJECT NO.
						PART NUMBER	REV
						LM 0943692-0001	AR

T.I. 13849

Change 1

6-56

Digital Systems Division

942773-9703



TEXAS INSTRUMENTS
INCORPORATED

DATE 09/22/77

LIST OF MATERIAL

PAGE 7 of

PART NUMBER
LM J943692-0001 REV
AR

PRINT ITEM NUMBER	QUANTITY PER ASSEMBLY	UNIT OF ISSUE	DWG. SIZE	PART NUMBER	DESCRIPTION	VENDOR PART NUMBER	
0065A					R22		
0067	0001.000	EA		0972947-0055	RES FIX 390 OHM 5% .5 W CARBON FILM	ROH - R-50	
0067A					R34		
0070	0001.000	EA		0539371-0455	RES FIX FILM 5.36K OHM 1% .13 WATT	COR - NC4	
0070A					R57		
0071	0001.000	EA		0539370-0309	RES FIX FILM 162 OHM 1% .25 WATT	COR - NA55	
0071A					R59		
0072	0001.000	EA		0539370-0423	RES FIX FILM 2.49K OHM 1% .25 WATT	COR - NA55	
0072A					R60		
0074	0001.000	EA		0972946-0053	RES FIX 330 OHM 5% .25 W CARBON FILM	ROH - R-25	
0074A					R21		
0077	0002.000	EA		0972946-0058	RES FIX 510 OHM 5% .25 W CARBON FILM	ROH - R-25	
0077A					R13,R63		
0078	0001.000	EA		0972946-0051	RES FIX 270 OHM 5% .25 W CARBON FILM	ROH - R-25	
0078A					R83		
0080	0001.000	EA		0972947-0041	RES FIX 100 OHM 5% .5 W CARBON FILM	ROH - R-50	
0080A					R91		
0081	0001.000	EA		0972946-0137	RES FIX 1.0M OHM 5% .25 W CARBON FILM	ROH - R-25	
0081A					R65		
0082	0004.000	EA		0539795-0008	RES VAR CERMET 2.0 K OHMS 10% .75 WATT	BOU -3069P-1-202	
DRAFTSMAN		DATE	CKD. DRAFTSMAN	DATE	DESIGN ENGINEER	DATE	TITLE
							CARD ASSY, MEM AUX & REF REG
APPD.-MFG		DATE	APPD. PROJECT ENGINEER	DATE	RELEASED	DATE	PROJECT NO.
						PART NUMBER	REV
						LM J943692-0001	AR

T.I. 13849

Change 1

6-57

Digital Systems Division

942773-9703



TEXAS INSTRUMENTS
INCORPORATED

DATE 09/22/77

LIST OF MATERIAL

PAGE 8 of

PART NUMBER
LM 0943692-0001 REV
AR

PRINT ITEM NUMBER	QUANTITY PER ASSEMBLY	UNIT OF ISSUE	DWG. SIZE	PART NUMBER	DESCRIPTION	VENDOR PART NUMBER		
0082A					R29,R92,R98,R99			
0083	00001.000	EA		0972934-0006	DIODE,1N751A 5.1 V 5% SIL VOLT REG	QPL - 1N751A		
0083A					CR16			
0084	00001.000	EA		0972934-0010	DIODE,1N755A 7.5 V 5% SIL VOLT REG	QPL - 1N755A		
0084A					CR17			
0085	00001.000	EA		0972777-0002	TRANSISTOR-N-P-N POWER 2N3714	MOT - 2N3714		
0085A					Q14			
0086	00002.000	EA		0222224-0305	NETWORK LM305H OPERATIONAL AMP	-LM305H		
0086A					AR1,AR3			
0087	00001.000	EA		0972948-0001	TRANSISTOR, NPN, GEN. PURP. SW TO-5	TI - 2N2219A		
0087A					Q35			
0088	00002.000	EA		0972929-0373	CAP FIX CERAMIC 47.0 PF 10 % 200 V	QPL - M39014/10-137		
0088A					C3,C6			
0089	00004.000	EA		0972929-0391	CAP FIX CERAMIC 470 PF 10 % 200 V	QPL -M39014/01-139A		
0089A					C4,C9,C10,C11			
0090	00002.000	EA		0972924-0018	CAP FIX TANT SOLID 6.8 MFD 10 % 35 VOLT	QPL -M39003/1-2304		
0090A					C15 C16			
0091	00005.000	EA		0972924-0019	CAP FIX TANT SOLID 22 MFD 10 % 35 VOLT	QPL -M39003/1-2306		
0091A					C12,C27,C28,C33,C37			
0092	00001.000	EA		0972924-0007	CAP FIX TANT SOLID 120 MFD 10 % 10 VOLT	QPL -M39003/1-2205		
DRAFTSMAN		DATE	CKD DRAFTSMAN	DATE	DESIGN ENGINEER	DATE	TITLE	
APPD. MFG.		DATE	APPD. PROJECT ENGINEER	DATE	RELEASED	DATE	PROJECT NO.	
							PART NUMBER LM 0943692-0001	REV AR

TI 13849

Change 1

6-58

Digital Systems Division

942773-9703

Change 1

6-59

Digital Systems Division



TEXAS INSTRUMENTS
INCORPORATED

DATE 09/22/77

LIST OF MATERIAL

PAGE 9 of

PART NUMBER	REV
LM 0943692-0001	AR

PRINT ITEM NUMBER	QUANTITY PER ASSEMBLY	UNIT OF ISSUE	DWG. SIZE	PART NUMBER	DESCRIPTION	VENDOR PART NUMBER	
00923					C7		
0093	00002.000	EA		0230855-1000	CAP 100.0 MF 50V	SPK -390-107-0050	
0093A					C1,C5		
0094	00001.000	EA		0230917-0010	CAP 200.0 MF 25V 75/-10	SPR -300-20760250Hz	
0094A					C14		
0096	00008.000	EA		0235341-0000	SOCKET XST TO-3 CASE	EBY -9866-15-1	
0097	00002.000	EA		0412713-0001	DIODE, 1N1614		
0097A					CR4, CR5		
0100	00001.000	EA		0943694-0002	CHANNEL, HEATSINK		
0104	00001.000	EA		0943693-0001	PWB, MEM AUX & REF REG-CARD		
0107	00001.000	EA		0539373-0500	RES FIX FILM 15.8K OHM 1% .375 WATT	COR -NA60-100PPM/C	
0107A					R44		
0108	00001.000	EA		0539370-0421	RES FIX FILM 2.37K OHM 1% .25 WATT	CUR - NA55	
0108A					R45		
0109	00001.000	EA		0539370-0429	RES FIX FILM 2.87K OHM 1% .25 WATT	CUR - NA55	
0109A					R24		
0110	00001.000	EA		0539370-0464	RES FIX FILM 6.65K OHM 1% .25 WATT	CUR - NA55	
0110A					R23		
0111	REF	EA		0943695-9901	DIAG, SCHEM, MEM AUX & REF REG		
0112	00002.000	EA		0539468-0002	DIODE, 1N4002 1AMP 100PIV RECTIFIER	TI - IN4002	
DRAFTSMAN		DATE	CKD. DRAFTSMAN	DATE	DESIGN ENGINEER	DATE	TITLE
							CARD ASSY, MEM AUX & REF REG
APPD.-MFG		DATE	APPD. PROJECT ENGINEER	DATE	RELEASED	DATE	PROJECT NO.
						PART NUMBER	REV
						LM 0943692-0001	AR

TI 13849



942773-9703



TEXAS INSTRUMENTS
INCORPORATED

DATE 09/22/77

LIST OF MATERIAL

PAGE 10 of

PART NUMBER	REV
LM 0943692-0001	AK

PRINT ITEM NUMBER	QUANTITY PER ASSEMBLY	UNIT OF ISSUE	DWG. SIZE	PART NUMBER	DESCRIPTION	VENDOR PART NUMBER	
0112A					CR34,CR35		
0114	00001.000	EA		0972946-0103	RES FIX 39 K OHM 5 % .25 W CARBON FILM	ROH - R-25	
0114A					R93		
0115	00002.000	EA		0972947-0062	RES FIX 750 OHM 5% .5 W CARBON FILM	ROH - R-50	
0115A					R96 R97		
0116	00004.000	EA		0972924-0017	CAP FIX TANT SOLID 1.0 MFD 10 % 35 VOLT	SPR -1500105A9035A	
0116A					C8,C25,C26,C29		
0118	00001.000	EA		0507315-0010	CAP 700.00 MF 50V 18%	SPR -3907076056P4	
0118A					C24		
0119	00001.000	EA		0972872-0020	NETWORK,LM 340-15K VOLTAGE REGULATOR	- -	
0119A					AR4		
0120	00001.000	EA		0972872-0008	NETWORK,LM 320K-15 VOLTAGE REGULATOR	- -	
0120A					AR5		
0121	00001.000	EA		0972978-0105	RES FIX COMP 1.0 W 1.5 K OHMS 5 %	QPL -RC32G152JS	
0121A					R4		
0122	00008.000	EA		0996521-0003	INSULATOR GRAY .009 THERMALLY COND	055285-7403-09FK-04	
0123	00002.000	EA		0972115-0001	SOCKET TD-66	EBY - 9866-17-02	
0125	00020.000	EA		0411101-0058	LOCKWASHER #6 EXTERNAL TOOTH CRES	QPL - MS35335-58	
0126	00007.000	EA		0411101-0057	LOCKWASHER # 4 EXTERNAL TOOTH CRES	QPL - MS35335-57	
0127	00003.000	EA		0416453-0021	NUT,PLAIN,4-40 UNC-2B HEX,CRES,SMALL	QPL - NAS671-C4	
DRAFTSMAN		DATE	CKD. DRAFTSMAN	DATE	DESIGN ENGINEER	DATE	TITLE
					CARD ASSY, MEM AUX & REF REG		
APPD -MFG		DATE	APPD PROJECT ENGINEER	DATE	RELEASED	DATE	PROJECT NO.
						PART NUMBER	REV
						LM 0943692-0001	AK

T.I. 13849

Change 1

6-60

Digital Systems Division

942773-9703



TEXAS INSTRUMENTS
INCORPORATED

DATE 09/22/77

LIST OF MATERIAL

PAGE 11 of

PART NUMBER	REV
LM 0943692-0001	AR

PRINT ITEM NUMBER	QUANTITY PER ASSEMBLY	UNIT OF ISSUE	DWG. SIZE	PART NUMBER	DESCRIPTION	VENDOR PART NUMBER	
0128	00002.000	EA		0418356-2371	CAP, FIXED, 6.8 MF, 10%		
0128					C23, C32		
0129	00002.000	EA		0972947-0065	RES FIX 1.0K OHM 5% .5 W CARBON FILM	ROH - R-50	
0129					R94, R95		
0131	00020.000	EA		J235057-0001	SCREW 6-32X9/16 BH SST		
0133	REF	EA		0943711-9901	TEST PROC, CARD ASSY, MEM AUX & REF REG		
0134	00004.000	EA		0972988-0016	SCREW 4-40 X .438 PAN HEAD CRES		
0138	00004.000	EA		0085936-0004	EYELET-ROLLED FLANGE	US - SE-25	
0139	00006.000	EA		0085936-0012	EYELET .089 BARREL OD X .250 LG FLANGE	USH - SE-38	
0140	00001.000	EA		0972603-0001	TRANSISTOR TIP640 DARLINGTON, POWER NPN	TI - TIP640	
0140					Q46		
0141	00003.000	EA		0972988-0014	SCREW 4-40 X .312 PAN HEAD CRES		
0142	AR	FT		0411400-0018	WIRE, BARE TINNED, 18AWG, COPPER BUS	IWP - 18-630	
0143	00002.000	EA		0531264-0001	TRANSIPAD 8 LEAD		
0144	00000.500	FT		0538592-4999	WIRE #20 AWG SOLID WHITE TYPE ETFE	- M22759/XX-20-	
0145	00002.000	EA		0416453-0024	NUT, #10 HEX SMALL PATTERN		
0146	00002.000	EA		0411104-0138	WASHER #10 LOCKSPLIT	QPL - MS35338-138	
0147	00001.000	EA		0972786-0001	TRANSISTOR, TIP645 PNP SILICON DARL		
0147					Q47		
0148	00003.000	EA		0972955-0001	XSTR 2N2369A, NPN, HIGH SPEED SW, TO-18	MOT - 2N2369A	
DRAFTSMAN		DATE	CKD. DRAFTSMAN	DATE	DESIGN ENGINEER	DATE	TITLE
							CARD ASSY, MEM AUX & REF REG
APPD.-MFG.		DATE	APPD. PROJECT ENGINEER	DATE	RELEASED	DATE	PROJECT NO.
						PART NUMBER	REV
						LM 0943692-0001	AR

T.I. 13849

Change 1

6-6 1

Digital Systems Division



942773-9703



TEXAS INSTRUMENTS
INCORPORATED

DATE 09/22/77

LIST OF MATERIAL

PAGE 12 of

PART NUMBER	REV
LM 0943692-0001	AR

PRINT ITEM NUMBER	QUANTITY PER ASSEMBLY	UNIT OF ISSUE	DWG. SIZE	PART NUMBER	DESCRIPTION	VENDOR PART NUMBER	
0148A					Q20 Q23 Q25		
0149	00001.000	EA		0972372-0001	NETWORK, LM 320H-05 VOLTAGE REGULATUR	- -	
0149A					AR6		
0151	00002.000	EA		0972965-0024	CAP FIX CERAMIC .100 MF 10% 100V	QPL - CK068X104K	
0151A					C38, C31		
DRAFTSMAN		DATE	CKD DRAFTSMAN	DATE	DESIGN ENGINEER	DATE	TITLE
							CARD ASSY, MEM AUX & REF REG
APPD. MFG.		DATE	APPD. PROJECT ENGINEER	DATE	RELEASED	DATE	PROJECT NO.
						PART NUMBER	REV
						LM 0943692-0001	AR

T.I. 13849

Change 1

6-62

Digital Systems Division

942773-9703

Change 1

6-63

Digital Systems Division



TEXAS INSTRUMENTS
INCORPORATED

DATE 09/22/77

LIST OF MATERIAL

PAGE 1 of

LM 0943692-0002	PART NUMBER	REV
		AR

PRINT ITEM NUMBER	QUANTITY PER ASSEMBLY	UNIT OF ISSUE	DWG. SIZE	PART NUMBER	DESCRIPTION	VENDOR PART NUMBER
0003	00003.000	EA		J184262-0001	PAD, MOUNTING, TO-5, 4 LEAD, RED	THR - 7717-5
0004	00003.000	EA		J419368-0002	HEATSINK, TRANSISTOR	WAK - NF-207
0006	00001.000	EA		J222224-2741	NETWORK SN72741P OPERATIONAL AMP	-SN72741P
0006A					AR2	
0008	00003.000	EA		0972958-0001	TRANSISTOR, PNP, GEN. PURP. SW TO-5	TI - 2N2905A
0008A					Q2, Q17, Q18	
0010	00001.000	EA		0972959-0001	TRANSISTOR, 2N3055 NPN 70V 1.5N TO-3	TI - 2N3055
0010A					Q3	
0011	00003.000	EA		0800523-0001	TRANSISTOR A5T2907 PNP SILICON	TI- -A5T2907
0011A					Q1, Q27, Q26	
0013	00004.000	EA		0972057-0001	TRANSISTOR-A5T2222 NPN SILICON	TI- -A5T2222
0013A					Q4, Q5, Q19, Q36	
0016	00001.000	EA		0972934-0006	DIODE, 1N751A 5.1 V 5% SIL VOLT REG	WPL - 1N751A
0016A					CR1	
0020	00003.000	EA		0972932-0001	DIODE, 1N914B SWITCHING 75V PIV 75MA 4NS	TI - 1N914B
0020A					CR2 CR12 CR21	
0022	00002.000	EA		0534348-0001	CAP FIX CERAMIC .10 MF 20/80 % 10V	CRL - UK10-104
0022A					C17, C20	
0024	00001.000	EA		0972946-0017	RES FIX 10.0 OHM 5 % .25 W. CARBON FILM	RUH - R-25
0024A					R5	

DRAFTSMAN	DATE	CKD. DRAFTSMAN	DATE	DESIGN ENGINEER	DATE	TITLE		
						CARD ASSY, MEM AUX & REF REG		
APPD.-MFG.	DATE	APPD. PROJECT ENGINEER	DATE	RELEASED	DATE	PROJECT NO.		
							LM 0943692-0002	REV AR

T.I. 13849



942773-9703



TEXAS INSTRUMENTS
INCORPORATED

DATE 09/22/77

LIST OF MATERIAL

PAGE 2 of

PART NUMBER	REV
LM 0943692-0002	AR

PRINT ITEM NUMBER	QUANTITY PER ASSEMBLY	UNIT OF ISSUE	DWG. SIZE	PART NUMBER	DESCRIPTION	VENDOR PART NUMBER	
0025	00001.000	EA		0233133-0001	RES 2.0000 OHM .5 W 5. R1	AB -EB20G5	
0025A							
0026	00001.000	EA		0972946-0041	RES FIX 100 OHM 5 % .25 W CARBON FILM R15	ROH - R-25	
0026A							
0029	00004.000	EA		0972947-0053	RES FIX 330 OHM 5% .5 W CARBON FILM R35,R36,R37,R38	ROH - R-50	
0029A							
0030	00004.000	EA		0972946-0061	RES FIX 680 OHM 5 % .25 W CARBON FILM R40,R41,R51,R7	ROH - R-25	
0030A							
0032	00001.000	EA		0418161-0003	DIODE REFERENCE,6.2V 5% TEMP CCMP CR8	QPL - IN827JAN	
0032A							
0033	00002.000	EA		0972946-0065	RES FIX 1.0K OHM 5% .25 W CARBON FILM R2,R39	ROH - R-25	
0033A							
0034	00001.000	EA		0539370-0412	RES FIX FILM 1.91K OHM 1% .25 WATT R17	COR - NA55	
0034A							
0035	00001.000	EA		0972946-0069	RES FIX 1.5K OHM 5 % .25 W CARBON FILM R6	ROH - R-25	
0035A							
0039	00002.000	EA		0539370-0437	RES FIX FILM 3.48K OHM 1% .25 WATT R30 R58	COR -NA55D-100PPM/L	
0039A							
0040	00002.000	EA		0972946-0081	RES FIX 4.7K OHM 5 % .25 W CARBON FILM R62,R81	ROH - R-25	
0040A							
DRAFTSMAN		DATE	CKD. DRAFTSMAN	DATE	DESIGN ENGINEER	DATE	TITLE
							CARD ASSY, MEM AUX & REF REG
APPD. MFG.		DATE	APPD. PROJECT ENGINEER	DATE	RELEASED	DATE	PROJECT NO.
						PART NUMBER	REV
						LM 0943692-0002	AR

TI 13849

Change 1

6-64

Digital Systems Division

942773-9703

Change 1

6-65

Digital Systems Division



TEXAS INSTRUMENTS
INCORPORATED

DATE 09/22/77

LIST OF MATERIAL

PAGE 3 of

PART NUMBER	REV
LM 0943692-0002	AR

PRINT ITEM NUMBER	QUANTITY PER ASSEMBLY	UNIT OF ISSUE	DWG. SIZE	PART NUMBER	DESCRIPTION	VENDOR PART NUMBER	
0042	00002.000	EA		0972946-0072	RES FIX 2.5K OHM 5 % .25 W CARBON FILM R61,R28	ROH - R-25	
0042A							
0054	00001.000	EA		0539370-0462	RES FIX FILM 6.34K OHM 1% .25 WATT R16	COR - NA55	
0054A							
0055	00001.000	EA		0972947-0081	RES FIX 4.7K OHM 5% .5 W CARBON FILM R3	ROH - R-50	
0055A							
0070	00001.000	EA		0539371-0455	RES FIX FILM 5.36K OHM 1% .13 WATT R57	COR - NC4	
0070A							
0071	00001.000	EA		0539370-0309	RES FIX FILM 162 OHM 1% .25 WATT R59	COR - NA55	
0071A							
0072	00001.000	EA		0539370-0423	RES FIX FILM 2.49K OHM 1% .25 WATT R60	COR - NA55	
0072A							
0077	00001.000	EA		0972946-0058	RES FIX 510 OHM 5 % .25 W CARBON FILM R13	ROH - R-25	
0077A							
0078	00001.000	EA		0972946-0051	RES FIX 270 OHM 5 % .25 W CARBON FILM R83	ROH - R-25	
0078A							
0082	00001.000	EA		0539795-0008	RES VAR CERMET 2.0 K OHMS 10 % .75 WATT R29	BOU -3069P-1-202	
0082A							
0089	00001.000	EA		0972929-0391	CAP FIX CERAMIC 470 PF 10 % 200 V C4	QPL -M39014/J1-1391	
0089A							
DRAFTSMAN		DATE	CKD. DRAFTSMAN	DATE	DESIGN ENGINEER	DATE	TITLE
							CARD ASSY, MEM AUX & REF REG
APPD. MFG.		DATE	APPD. PROJECT ENGINEER	DATE	RELEASED	DATE	PROJECT NO.
						PART NUMBER	REV
						LM 0943692-0002	AR

T.I. 13849



942773-9703



TEXAS INSTRUMENTS
INCORPORATED

DATE 09/22/77

LIST OF MATERIAL

PAGE 4 of

PART NUMBER	REV
LM 0943692-0002	AR

PRINT ITEM NUMBER	QUANTITY PER ASSEMBLY	UNIT OF ISSUE	DWG. SIZE	PART NUMBER	DESCRIPTION	VENDOR PART NUMBER	
0593	00001.000	EA		0230855-1000	CAP 100.0 MF 50V	SPR -390-107-G050	
0093A					C1		
0094	00001.000	EA		0230917-0010	CAP 200.0 MF 25V 75/-10	SPR -300-207G025DH2	
0094A					C14		
0095	00001.000	EA		0235341-0000	SOCKET XST TO-3 CASE	EBY -9866-15-1	
0100	00001.000	EA		0943694-0002	CHANNEL, HEATSINK		
0104	00001.000	EA		0943693-0001	PWB, MEM AUX & REF REG-CARD		
0111	REF	EA		0943732-9901	DIAG SCHEM, MEM AUX & REF REG		
0122	00001.000	EA		0996521-0003	INSULATOR GRAY .009 THERMALLY COND	055285-7403-05FR-04	
0125	00002.000	EA		0411101-0058	LOCKWASHER #6 EXTERNAL TOOTH CRES	QPL - MS35335-58	
0126	00004.000	EA		0411101-0057	LOCKWASHER # 4 EXTERNAL TOOTH CRES	QPL - MS35335-57	
0128	00001.000	EA		0418356-2371	CAP, FIXED, 6.8 MF, 10%		
0128A					C23		
0131	00002.000	EA		0235057-0001	SCREW 6-32X9/16 BH SST		
0133	REF	EA		0943711-9901	TEST PROC, CARD ASSY, MEM AUX & REF REG		
0134	00004.000	EA		0972988-0016	SCREW 4-40 X .438 PAN HEAD CRES		
DRAFTSMAN		DATE	CKD. DRAFTSMAN	DATE	DESIGN ENGINEER	DATE	TITLE
							CARD ASSY, MEM AUX & REF REG
APPD. MFG.		DATE	APPD. PROJECT ENGINEER	DATE	RELEASED	DATE	PROJECT NO.
						PART NUMBER	REV
						LM 0943692-0002	AR

TI 13849

Change 1

6-66

Digital Systems Division

942773-9703

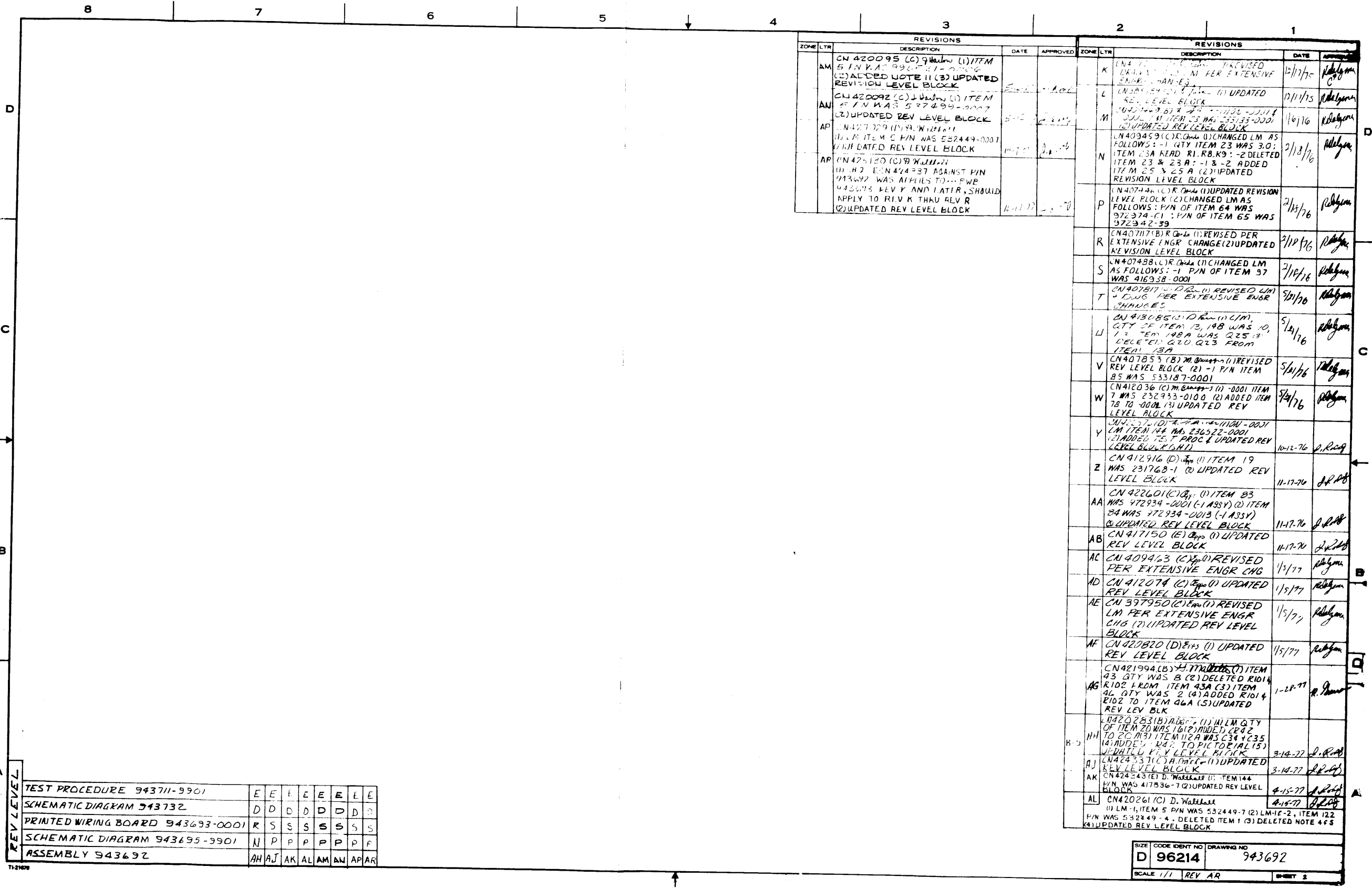

REVISIONS					REVISIONS				
ZONE	LTR	DESCRIPTION	DATE	APPROVED	ZONE	LTR	DESCRIPTION	DATE	APPROVED
AM		CN 420095 (C) 9th level (1) ITEM 5 P/N WAS 990-01-0000 (2) ADDED NOTE 11 (3) UPDATED REV LEVEL BLOCK	5-17-76	J.R. 209	K		CN 420095 (C) 9th level (1) ITEM 5 P/N WAS 990-01-0000 (2) ADDED NOTE 11 (3) UPDATED REV LEVEL BLOCK	5-17-76	J.R. 209
AN		CN 420092 (C) 1st level (1) ITEM 5 P/N WAS 527499-0007 (2) UPDATED REV LEVEL BLOCK	5-17-76	J.R. 209	L		CN 420092 (C) 1st level (1) ITEM 5 P/N WAS 527499-0007 (2) UPDATED REV LEVEL BLOCK	5-17-76	J.R. 209
AP		CN 420092 (C) 1st level (1) ITEM 5 P/N WAS 527499-0007 (2) UPDATED REV LEVEL BLOCK	5-17-76	J.R. 209	M		CN 420092 (C) 1st level (1) ITEM 5 P/N WAS 527499-0007 (2) UPDATED REV LEVEL BLOCK	5-17-76	J.R. 209
AP		CN 420120 (C) 9th level (1) ITEM 11 P/N WAS 532449-0001 (2) ADDED NOTE 11 (3) UPDATED REV LEVEL BLOCK	5-17-76	J.R. 209	N		CN 420120 (C) 9th level (1) ITEM 11 P/N WAS 532449-0001 (2) ADDED NOTE 11 (3) UPDATED REV LEVEL BLOCK	5-17-76	J.R. 209
AP		CN 420120 (C) 9th level (1) ITEM 11 P/N WAS 532449-0001 (2) ADDED NOTE 11 (3) UPDATED REV LEVEL BLOCK	5-17-76	J.R. 209	P		CN 420120 (C) 9th level (1) ITEM 11 P/N WAS 532449-0001 (2) ADDED NOTE 11 (3) UPDATED REV LEVEL BLOCK	5-17-76	J.R. 209
					R		CN 407117 (B) R Q-14 (1) REVISED PER EXTENSIVE ENGR CHANGE (2) UPDATED REV LEVEL BLOCK	2/12/76	R. 209
					S		CN 407498 (C) R Q-14 (1) CHANGED LM AS FOLLOWS: -1 P/N OF ITEM 97 WAS 416938-0001	2/12/76	R. 209
					T		CN 407817 (C) R Q-14 (1) REVISED LM AS FOLLOWS PER EXTENSIVE ENGR CHANGES	5/21/76	R. 209
					L		CN 413085 (C) R Q-14 (1) LM QTY OF ITEM 13, 198 WAS 10, 13 ITEM 148A WAS 25 13 DELETED Q20, Q23 FROM ITEM 13A	5/21/76	R. 209
					V		CN 407853 (B) R Q-14 (1) REVISED REV LEVEL BLOCK (2) -1 P/N ITEM 85 WAS 533187-0001	5/21/76	R. 209
					W		CN 412036 (C) R Q-14 (1) -0001 ITEM 7 WAS 232933-0100 (2) ADDED ITEM 78 TO -0001 (3) UPDATED REV LEVEL BLOCK	5/21/76	R. 209
					Y		CN 412036 (C) R Q-14 (1) -0001 ITEM 7 WAS 232933-0100 (2) ADDED ITEM 78 TO -0001 (3) UPDATED REV LEVEL BLOCK (4) 11	10-12-76	J.R. 209
					Z		CN 412916 (D) R Q-14 (1) ITEM 19 WAS 231768-1 (2) UPDATED REV LEVEL BLOCK	11-17-76	J.R. 209
					AA		CN 422601 (C) R Q-14 (1) ITEM 83 WAS 472934-0001 (-1 ASSY) (2) ITEM 84 WAS 472934-0013 (-1 ASSY) (3) UPDATED REV LEVEL BLOCK	11-17-76	J.R. 209
					AB		CN 417150 (E) R Q-14 (1) UPDATED REV LEVEL BLOCK	11-17-76	J.R. 209
					AC		CN 409463 (C) R Q-14 (1) REVISED PER EXTENSIVE ENGR CHG	1/5/77	R. 209
					AD		CN 412074 (C) R Q-14 (1) UPDATED REV LEVEL BLOCK	1/5/77	R. 209
					AE		CN 397950 (C) R Q-14 (1) REVISED LM PER EXTENSIVE ENGR CHG (2) UPDATED REV LEVEL BLOCK	1/5/77	R. 209
					AF		CN 420820 (D) R Q-14 (1) UPDATED REV LEVEL BLOCK	1/5/77	R. 209
					AG		CN 421994 (B) R Q-14 (1) ITEM 43 QTY WAS 8 (2) DELETED R101 & R102 FROM ITEM 43A (3) ITEM 44 QTY WAS 2 (4) ADDED R101 & R102 TO ITEM 46A (5) UPDATED REV LEVEL BLK	1-28-77	J.R. 209
					HH		CN 420283 (B) R Q-14 (1) ITEM QTY OF ITEM 20 WAS 16 (2) ADDED R102 TO 20 (3) ITEM 112A WAS C34 + C35 (4) ADDED R102 TO PICTORIAL (5) UPDATED REV LEVEL BLOCK	3-14-77	J.R. 209
					AJ		CN 424337 (C) R Q-14 (1) UPDATED REV LEVEL BLOCK	3-14-77	J.R. 209
					AK		CN 424337 (C) R Q-14 (1) ITEM 144 P/N WAS 417836-7 (2) UPDATED REV LEVEL BLOCK	4-15-77	J.R. 209
					AL		CN 420261 (C) D. WALLACE (1) LM -1, ITEM 5 P/N WAS 532449-7 (2) LM -1F-2, ITEM 122 P/N WAS 532449-4 - DELETED ITEM 1 (3) DELETED NOTE 4F5 (4) UPDATED REV LEVEL BLOCK	4-15-77	J.R. 209

REV LEVEL	TEST PROCEDURE 943711-9901	E	E	E	E	E	E	E	E
	SCHMATIC DIAGRAM 943732	D	D	D	D	D	D	D	D
	PRINTED WIRING BOARD 943693-0001	R	S	S	S	S	S	S	S
	SCHMATIC DIAGRAM 943695-9901	N	P	P	P	P	P	P	P
	ASSEMBLY 943692	AH	AJ	AK	AL	AM	AN	AP	AR

SIZE	CODE	IDENT NO	DRAWING NO
D	96214		943692
SCALE	1/1	REV	AR
			SHEET 2

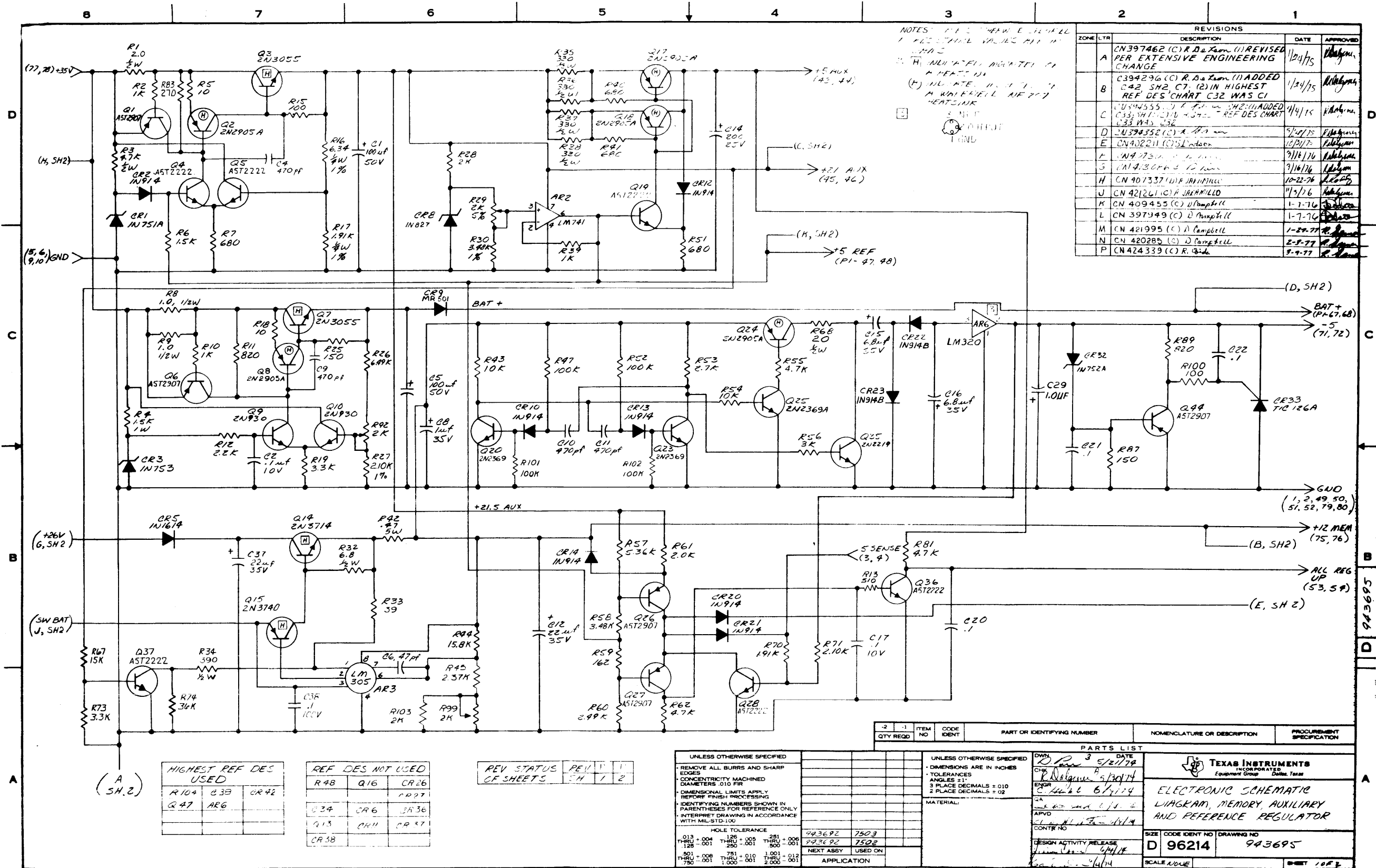

NOTES: 1. ALL DIMENSIONS ARE IN INCHES UNLESS OTHERWISE SPECIFIED.
 2. HOLE TOLERANCE: .010 INCHES.
 3. DIMENSIONS ARE IN INCHES UNLESS OTHERWISE SPECIFIED.
 4. TOLERANCES: ANGLES ±1°; 3 PLACE DECIMALS ±0.010; 2 PLACE DECIMALS ±0.02.

REVISIONS				
ZONE	LTR	DESCRIPTION	DATE	APPROVED
A		CN397462 (C) R. De Zorn (REVISED PER EXTENSIVE ENGINEERING CHANGE)	11/24/75	[Signature]
B		CN394296 (C) R. De Zorn (ADDED Q42, SH2, C7, (2) IN HIGHEST REF DES CHART C32 WAS C1)	11/24/75	[Signature]
C		CN394555 (C) R. De Zorn (ADDED C33, SH2, C7, (2) IN HIGHEST REF DES CHART C33 WAS C32)	11/24/75	[Signature]
D		CN394352 (C) R. De Zorn	5/12/75	[Signature]
E		CN402211 (C) J. De Zorn	10/21/75	[Signature]
F		CN402211 (C) J. De Zorn	9/16/76	[Signature]
G		CN402211 (C) J. De Zorn	3/16/76	[Signature]
H		CN401337 (C) J. De Zorn	10-22-76	[Signature]
I		CN421261 (C) J. De Zorn	11/3/76	[Signature]
J		CN409455 (C) J. De Zorn	1-1-76	[Signature]
K		CN397449 (C) J. De Zorn	1-7-76	[Signature]
L		CN421995 (C) J. De Zorn	1-24-77	[Signature]
M		CN420285 (C) J. De Zorn	2-3-77	[Signature]
N		CN424339 (C) R. De Zorn	3-9-77	[Signature]

HIGHEST REF DES USED			REF DES NOT USED		
R104	Q38	CR42	R48	Q16	CR26
Q47	ARG		Q34	CR6	CR36
			Q13	CR11	CR37
			CR38		

REV STATUS	REV	DATE
OF SHEETS	1	1
	2	2

UNLESS OTHERWISE SPECIFIED:
 REMOVE ALL BURRS AND SHARP EDGES
 CONCENTRICITY MACHINED DIAMETERS .010 FIR
 DIMENSIONAL LIMITS APPLY BEFORE FINISH PROCESSING
 IDENTIFYING NUMBERS SHOWN IN PARENTHESES FOR REFERENCE ONLY
 INTERPRET DRAWING IN ACCORDANCE WITH MIL-STD-100

HOLE TOLERANCE	APPLY	USED ON
.013 - .004	THRU	.001
.125 - .005	THRU	.001
.251 - .006	THRU	.001
.501 - .008	THRU	.010
.750 - .001	THRU	2.000 - .001

UNLESS OTHERWISE SPECIFIED:
 DIMENSIONS ARE IN INCHES
 TOLERANCES: ANGLES ±1°; 3 PLACE DECIMALS ±0.010; 2 PLACE DECIMALS ±0.02

ITEM NO	CODE IDENT	PART OR IDENTIFYING NUMBER	NOMENCLATURE OR DESCRIPTION	PROCUREMENT SPECIFICATION
943692	7503			
943692	7502			

TEXAS INSTRUMENTS
 INCORPORATED
 Equipment Group Dallas, Texas

ELECTRONIC SCHEMATIC
 DIAGRAM, MEMORY, AUXILIARY
 AND REFERENCE REGULATOR

SIZE CODE IDENT NO DRAWING NO
D 96214 943695

SCALE: NONE SHEET 1 OF 2

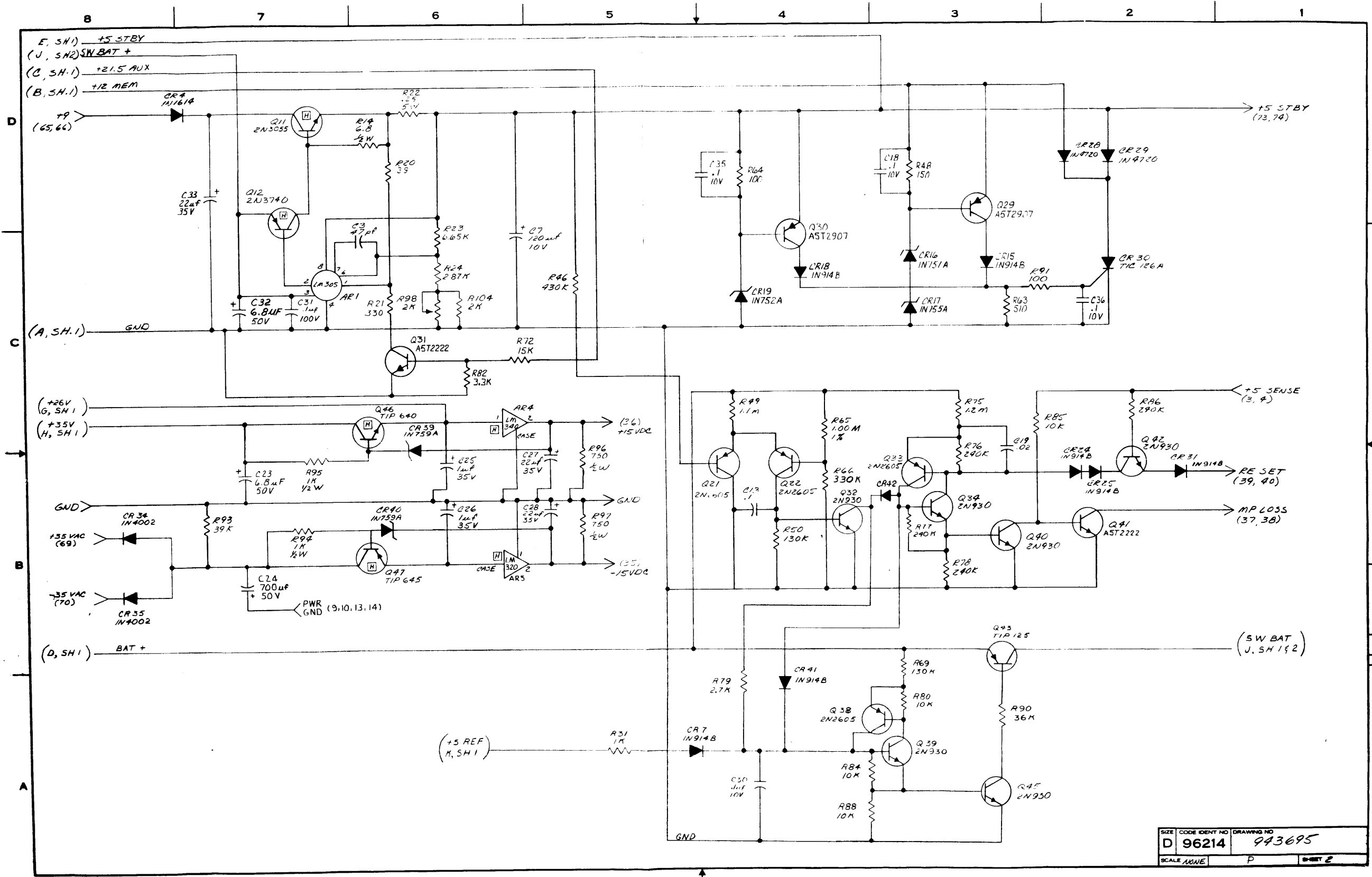

SIZE	CODE IDENT NO	DRAWING NO
D	96214	943695
SCALE	NONE	P



942773-9703

ALPHABETICAL INDEX



ALPHABETICAL INDEX

INTRODUCTION

The following index lists key words and concepts from the subject material of the manual together with the area(s) in the manual that supply major coverage of the listed concept. The numbers along the right side of the listing reference the following manual areas:

- Sections - References to Sections of the manual appear as “Section x” with the symbol x representing any numeric quantity.
- Appendixes - References to Appendixes of the manual appear as “Appendix y” with the symbol y representing any capital letter.
- Paragraphs - References to paragraphs of the manual appear as a series of alphanumeric or numeric characters punctuated with decimal points. Only the first character of the string may be a letter; all subsequent characters are numbers. The first character refers to the section or appendix of the manual in which the paragraph is found.
- Tables - References to tables in the manual are represented by the capital letter T followed immediately by another alphanumeric character (representing the section or appendix of the manual containing the table). The second character is followed by a dash (-) and a number:

Tx-yy

- Figures - References to figures in the manual are represented by the capital letter F followed immediately by another alphanumeric character (representing the section or appendix of the manual containing the figure). The second character is followed by a dash (-) and a number:

Fx-yy

- Other entries in the Index - References to other entries in the index are preceded by the word “See” followed by the referenced entry.



AC ON- Signal	4.2.1.3	Input Power Characteristics	T1-2
AC Detect	4.2.1.3	Internal Battery Check	5.2.2.1
All Reg Up- Signal	4.2.1.6, 1.2.2.6	Introduction, Maintenance	5.1
All Regulator Up Sensor Levels	T4-2	Logic Control Signals	4.3
All Regulators Up Detect	4.2.2.6	Main Regulator:	
Auxiliary Regulators	4.2.2, 4.2.2.4	Control, +5V	4.2.1
Auxiliary, and Reference Regulator, Memory	4.2.2	Overvoltage Protect, +5V	4.2.1.1
BAT+ Signal	4.2.2.3	+5V	4.2.1.1, 4.2.1
Battery	1.4	Maintenance:	
Charger	4.2.2.5	Introduction	5.1
Charger Check	5.2.2.3	Preventive	5.2
Charger Circuitry	4.2.2	Test Equipment for Power Supply	T5-1
Charging	4.1.5	Master Reset	4.2.1.7
Charging System	F4-7	Signal, MRESET-	4.2.1.7, 4.1.2
Check	5.2.2	Memory, Auxiliary, and Reference Regulator	4.2.2
Check, External	5.2.2.2	Memory Power Loss Latch	4.2.2.7
Check, Internal	5.2.2.1	Memory Power Loss Signal, MPLOSS-	4.1.2
Test Chart	F5-1	Memory Regulators, +5V Standby and +12V	4.2.2.1
Text Switch	1.4	Model 960B and 980B Computer Power Supply	F1-1
Block Diagram, Power Supply	F4-8	MPLOSS- Memory Power Loss Signal	4.1.2
Characteristics:		MRESET Drive Signal	4.2.1.8
Input Power	T1-2	MRESET- Master Reset	4.1.2, 4.2.1.7
Output Power	T1-3	On-Delay Signal	4.1.2, 4.2.1.4
Physical and Environmental	T1-1	On-Delay Circuit	4.2.1
Chart, Battery Test	F5-1	Operation General	3.1
Circuit Diagram, Switching Regulator	F4-2	Operation General Theory	4.1
Circuit for Switching Regulator, Current Limiting	F4-6	Output Power Characteristics	T1-3
Clean Air Filter	5.2.1	Output, Rectifier, Filter	4.2.4
Clock, 60-kHz	4.2.1.2	Overcurrent Protection	4.1.4
Commutating Diode Waveform-No Load	F4-10	Overload Detect	4.2.1.6
Computer Power Supply, Model 960B and 980B	F1-1	OVERLOAD- Signal	4.2.1.6
Controls, Power Supply	3.2, T3-1	Overvoltage Protect, +5V Main Regulator	4.2.1.1
Rear Panel	F3-1	Overvoltage Protection	4.1.3, 4.2.1, 4.2.2.8
Crowbar Circuits	4.1.3	Power Distribution Functional Diagram	F4.4
Crowbar Ref Point, +5V Reference and +5V STBY/ +12V MEM	4.2.2.3	Tolerances	T1-4
Current Limiting	4.1.4	Overvoltage Sensor Trigger Levels	T4-1
Circuit for Switching Regulator	F4-6	Physical and Environmental Characteristics	T1-1
Circuitry for Series Regulators	F4-5	POFF (Power Off) Signal	4.1.2, 4.2.1.8
Description of Power Supply	1.2	Power Characteristics:	
Detailed Theory Power Supply	4.2	Input	T1-2
Detect Circuit	4.2.1	Output	T1-3
Diagram:		Power Distribution Functional Diagram, Overvoltage Protection	F4.4
Overvoltage Protection and Power Distribution Functional	F4.4	Power Loss Indicator	1.4
Power Supply Block	F4-8	Power Off	4.2.1.8, 5.2.1.2
Switching Regulator Circuit	F4-2	Power On	5.2.1.1
Drawings	6.1	Power Supply:	
Environmental Characteristics, Physical	T1-1	Block Diagram	F4-8
External Battery Check	5.2.2.2	Controls	3.2, T3-1
Failure Location	T5-3	Description	1.2
Failure Types	T5-2	Detailed Theory	4.2
Functional Diagram, Overvoltage Protection and Power Distribution	F4-4	Maintenance, Test Equipment	T5-1
General Theory of Operation	4.1	Model 960B and 980B Computer	F1-1
		Position within Chassis	F2-1



Power Supply: (Continued)

Real Panel Controls	.F3-1
Removal	2.2
Specifications	1.3
Preventive Maintenance	5.2
Protection and Power Distribution Functional Diagram, Overvoltage	.F4-4
Protection:	
Overcurrent	4.1.4
Overvoltage	4.1.3
Tolerances, Overvoltage	.T1-4
Rectifier, Filter, and Output	4.2.4
REF ENBL- (Reference Enable) Signal	4.2.1.5
Reference Regulator, Memory, Auxiliary	4.2.2
Regulation	4.1.1
Regulator:	
Circuit Diagram, Switching	.F4-2
Phase Signal Generation	4.2.1.2
Waveforms, Switching	.F4-3
Regulators Up Detect, All	4.2.2.6
Removal, Power Supply	2.2
Reset Signal, MRESET- Master	4.2.1.7
Reset Switch	4.2.2.7
Reset, Master	4.1.2, 4.2.1.7
Scope-of-Manual	1.1
Sequencing and Control	4.1.2
Series Regulators, Current Limiting	
Circuitry	.F4-5
Signal Waveforms	5.5
Specifications, Power Supply	1.3
Switching Regulator:	
Circuit Diagram	.F4-2
Current Limiting Circuit	.F4-6
Waveforms	F4-3, F4-9
Test Equipment for Power Supply	
Maintenance	5.3, T5-1
Theory of Operation	4.1
Triangular Synchronizing Waveform	
Generation	4.2.1.2
Trouble Analysis	5.4
Turn-Off Sequence	4.2.1.10
Turn-On Sequence	4.2.1.9
Turn-On Sequence Timing	F4-12

Waveform:

1	.F5-2
2	.F5-3
3	.F5-4
4	.F5-5
5	.F5-6
6	.F5-7
7	.F5-8
8	.F5-9
9	F5-10
11	F5-11
Waveform-No Load, Commutating Diode	F4-10

Waveforms:

Signal	5.5
Waveforms, Switching Regulator	F4-3, F4-9

+5V:

Main	4.1.1
Main Regulator	4.2.1, 4.2.1.1
Main Regulator and Control	4.2.1
Main Regulator and Overvoltage	
Protect	4.2.1.1
Main Signal	4.1.2
Min Signal	4.2.1.6
Ramp Up	4.2.1.2, 4.2.1.5
Ref Signal	4.2.1.5, 4.2.2.3, 4.2.2.4
Reference and +5V STBY/ +12V MEM	
Crowbar Ref Point	4.2.2.3
Sense Signal	4.2.1.6
Standby and +12V Memory Regulators	4.2.2.1
STBY Signal	4.1.2, 4.2.2, 4.2.2.8
STBY/ +12V MEM Crowbar Ref Point, +5V Reference	4.2.2.3
-5V Crowbar	4.2.2.8
-5V Regulator	4.2.2, 4.2.2.2
60-kHz Clock	4.2.1.2
960B and 980B Computer Power Supply, Model	.F1-1
980B Computer Power Supply, Model 960B	.F1-1
+12V MEM:	
Crowbar Ref Point, +5V Reference and +5V STBY/	4.2.2.3
Regulators	4.2.2, 4.2.2.8
Regulators, +5V Standby	4.2.2.1
+21.5V AUX:	
Regulator	4.2.2.4
Signal	4.2.2.3

FOLD



NO POSTAGE
NECESSARY
IF MAILED
IN THE
UNITED STATES

BUSINESS REPLY MAIL
FIRST CLASS PERMIT NO. 7284 DALLAS, TX

POSTAGE WILL BE PAID BY ADDRESSEE

TEXAS INSTRUMENTS INCORPORATED
DIGITAL SYSTEMS GROUP

ATTN: TECHNICAL PUBLICATIONS
P.O. Box 2909 M/S 2146
Austin, Texas 78769



FOLD

**960B COMPUTER
SYSTEM
HARDWARE
MANUALS**

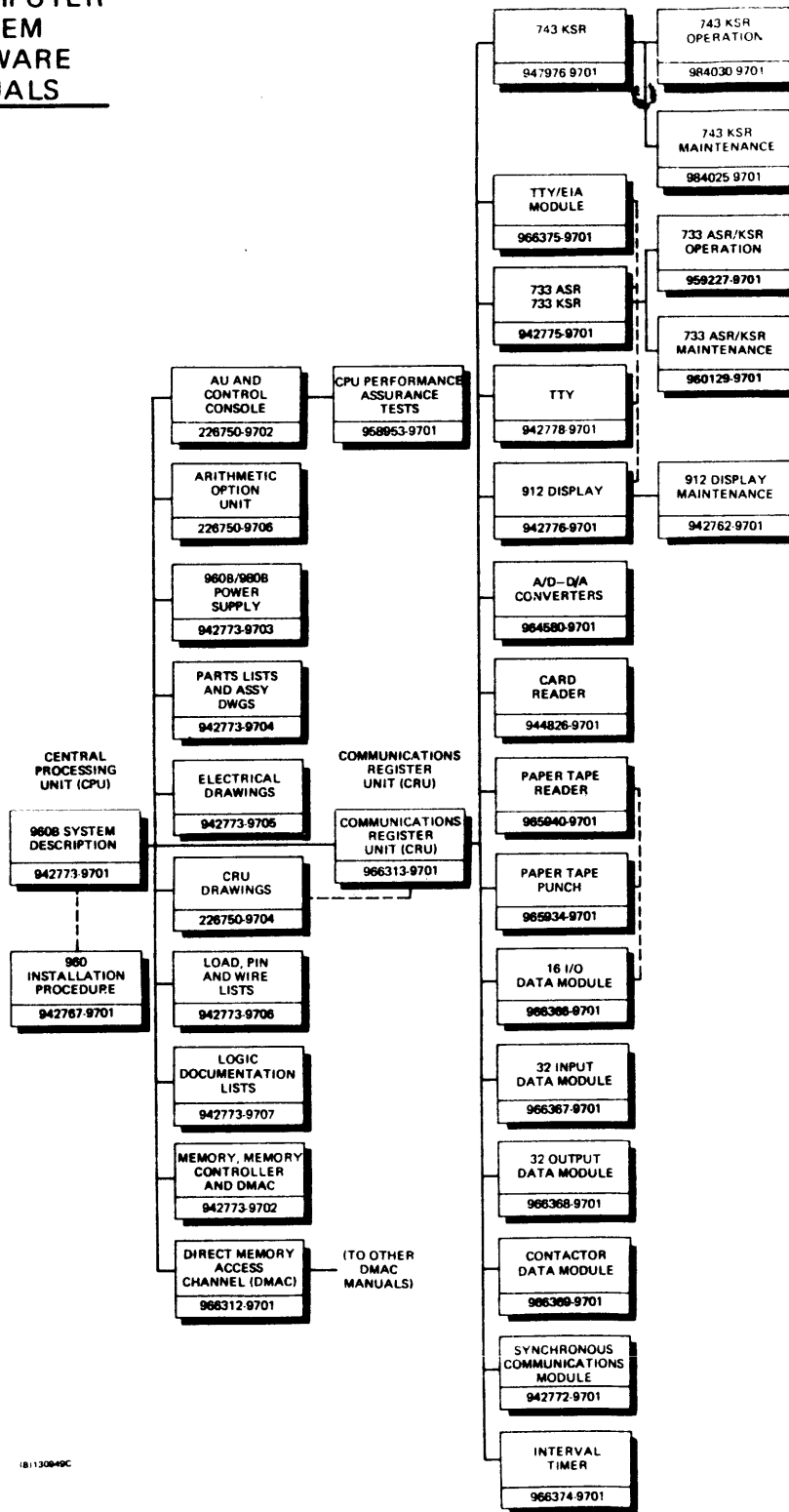

181130849C



TEXAS INSTRUMENTS
INCORPORATED

DIGITAL SYSTEMS DIVISION
POST OFFICE BOX 2909 • AUSTIN, TEXAS 78769