



**PLEASE CHECK FOR CHANGE INFORMATION
AT THE REAR OF THIS MANUAL.**

**4041 R04
UTILITY ROMPACK**

INSTRUCTION MANUAL

**Tektronix, Inc.
P.O. Box 500
Beaverton, Oregon 97077**

Serial Number _____

070-4699-00
Product Group 76

First Printing APR 1983
Revised JUL 1985

Copyright © 1983 Tektronix, Inc. All rights reserved.
Contents of this publication may not be reproduced in any
form without the written permission of Tektronix, Inc.

Products of Tektronix, Inc. and its subsidiaries are covered
by U.S. and foreign patents and/or pending patents.

TEKTRONIX, TEK, SCOPE-MOBILE, and  are
registered trademarks of Tektronix, Inc. TELEQUIPMENT
is a registered trademark of Tektronix U.K. Limited.

Printed in U.S.A. Specification and price change privileges
are reserved.

INSTRUMENT SERIAL NUMBERS

Each instrument has a serial number on a panel insert, tag,
or stamped on the chassis. The first number or letter
designates the country of manufacture. The last five digits
of the serial number are assigned sequentially and are
unique to each instrument. Those manufactured in the
United States have six unique digits. The country of
manufacture is identified as follows:

B000000	Tektronix, Inc., Beaverton, Oregon, USA
100000	Tektronix Guernsey, Ltd., Channel Islands
200000	Tektronix United Kingdom, Ltd., London
300000	Sony/Tektronix, Japan
700000	Tektronix Holland, NV, Heerenveen, The Netherlands

4041R04 UTILITY ROMPACK

TABLE OF CONTENTS

	PAGE
Section 1 GENERAL DESCRIPTION	
Product Overview	1-1
Specifications	1-2
Installation and Removal	1-3
Section 2 REPLACEABLE PARTS	2-1
Section 3 ENGLISH ERROR MESSAGES	3-1
Section 4 "RADIANS", "DEGREES", "GRADS", AND "RCALLS" ROMCALLS	4-1
Section 5 INTERVAL/TIME-OF-DAY TIMER DEVICES	5-1
Section 6 SOFT ROMPACK LOADER	6-1
Section 7 PROM FILE SYSTEM	7-1
Appendix A ERROR MESSAGES	A-1
Appendix B SYNTAX AND DESCRIPTIVE FORMS	B-1
Index	

ILLUSTRATIONS

FIGURE NO.		PAGE
1-1.	Location of Rom Carrier	1-3
1-2.	Rom Pack and Rom Carrier	1-4

SECTION 1

GENERAL DESCRIPTION

The 4041R04 Utility Rompack contains several features that enhance the 4041 System Controller. These features include:

1. One-line English error messages.
2. Four new romcalls: "Degrees", "Radians", "Grads", and "Rcalls".
3. Interval/time of day timer devices.
4. Soft rompack loader.
5. PROM file system program/data files.

The above features are contained in a single set of roms totaling 16k bytes. This set of roms can be placed in any available slot in the 4041 rompack carrier.

PRODUCT OVERVIEW

English Error Messages

This feature provides the user with a one-line English error message for all detectable errors in the standard 4041 BASIC language and in any 4041 rompacks.

"Degrees", "Radians", "Grads", and "Rcalls" Romcalls

The "Degrees", "Radians", and "Grads" romcalls are parameterless romcalls that set the current trigonometric units to degrees, radians, or grads, respectively.

The "Rcalls" romcall is a parameterless romcall that displays all romcalls associated with each rompack in the system on the system console device.

Interval/Time of Day Timer Devices

Three timer devices are added to the 4041 to enable BASIC programs to be interrupted upon expiration of specified intervals of time or at a specified time of day.

Soft Rompack Loader

The "Loadroms" romcall allows users to load any 4041 rompack into random-access memory. The romcall passes as parameters the stream specifications for each rompack to be loaded. Once the rompacks are loaded, they become available for use just as if they were loaded into the rom carrier.

PROM File System

The PROM file system adds an additional I/O device, called PROM0, to the 4041. The PROM0 device allows ASCII or Item files to be read from programmable ROMs (PROMs). PROM0 is a read-only device that supports all 4041 BASIC language features that access files for reading, such as the READ, INPUT, DIR, OPEN, CLOSE, and SET SYSDEV statements and the TYPE function.

The user builds file images for storage on DC-100 tapes with the Tektronix-supplied utility program "PRMBLD". These images are transferred to PROMs by means of another Tektronix-supplied utility program, "RMXFER".

General Description

SPECIFICATIONS



Power Requirements

The power requirements for rom packs are included in the base instrument power requirements for the 4041. These requirements are:

Input Power: 120 Watts maximum

Output Power: 80 Watts maximum

Line Voltage Limits:

130 V Range: 90—132 Volts

230 V Range: 180—250 Volts

Line Frequency: 48—66 Hz

Line Fuse:

Low Range: 2.5A fast blow

High Range: 1.6A slow blow

Temperature

Operating: 32 to 130°F (0 to 55°C)

Non-Operating: -40 to 165°F (-40 to 75°C)

Altitude

Operating: 15,000 ft (4.5 km)

Non-Operating: 50,000 ft (15 km)

Humidity

Operating: 95% max

Non-Operating: 95% max at 150°F (65°C)

Static Immunity

Installed: 15 kV

Non-Installed: No immunity.

4041 Rom packs are static-sensitive when not installed. DO NOT TOUCH THE ROM LEADS ON THE UNDERSIDE OF THE ROM CARRIERS WITH AN INSTRUMENT OR FINGER—YOU MAY DAMAGE THE ROM PACK.

Vibration

Less than 0.025 inch (0.64 mm) p-p amplitude.

Shock

50 G's

Packaged Transportation

Meets NSTA requirements for packaged shock and vibration.

EMI

Meets FCC Part 15, Subpart J, Class A requirements, and VDE 0871, Class B requirements.

Physical Specifications (with latchbar)

Length: 3.5 in. (8.89 cm)

Width: 1.05 in. (2.67 cm)

Height: 0.35 in. (0.89 cm)

Weight: 0.564 oz. (16.1 g)

Memory Requirements

The Utility Rompack uses 1500 bytes of random access memory, in addition to the random access memory required to soft-load roms.

INSTALLATION AND REMOVAL

NOTE

When the 4041 is turned on, it automatically starts a series of self-tests. Part of this self-testing determines whether any rom packs are installed and checks that they are functioning correctly. Therefore, rom packs must be installed before turning on the 4041. The system does not recognize any rom packs unless they are correctly installed before the 4041 is turned on.

Removing the Rom Carrier

CAUTION

Turn the 4041 power off before removing the rom carrier. Never remove the rom carrier while the power is on. Removal with the power on can cause power fluctuations that can damage rom chips.

The rom carrier is a tray located behind the grill on the front of the 4041 (Figure 1-1).

To remove the carrier (if it is already installed), first remove the grill. The grill has a horizontal coin slot at its top; pry out the grill using a coin in the cutout. Pull the carrier out of its compartment using the carrier's plastic strap.

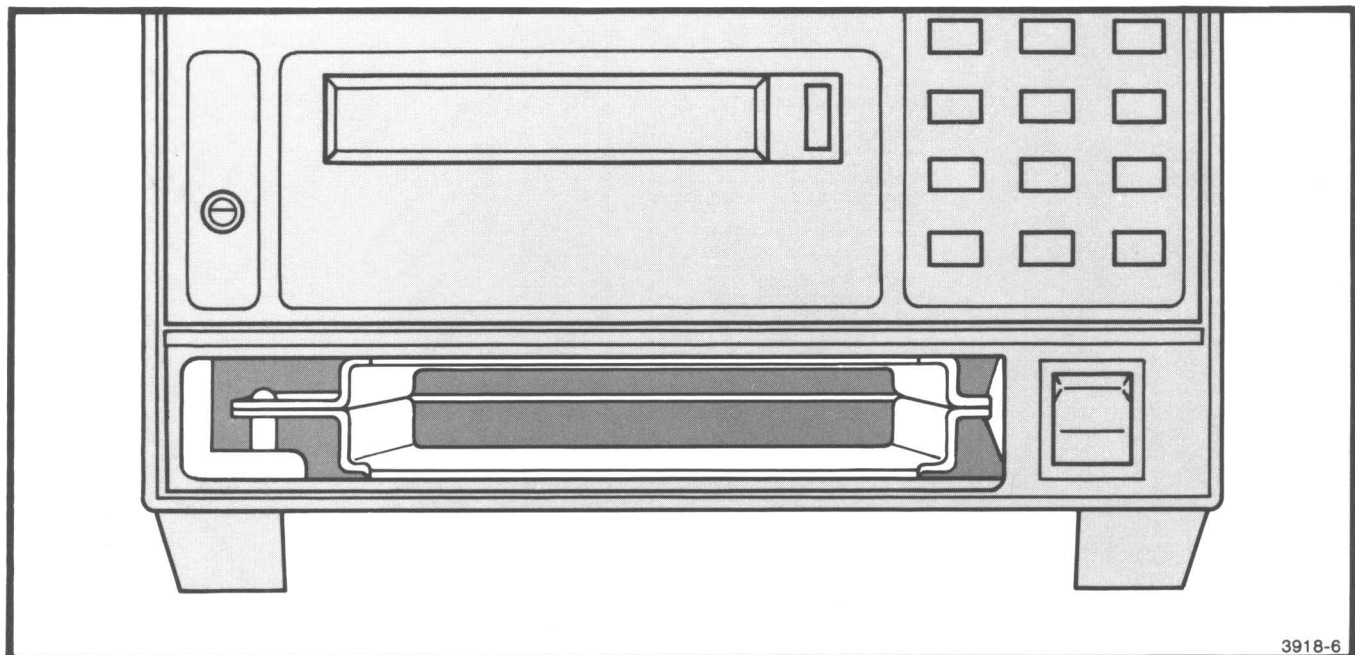

Figure 1-1. Location of ROM Carrier.

Putting the Rom Packs Into the Carrier

CAUTION

Do not touch the metal leads on the underside of the rom packs. The rom packs are static-sensitive and could be damaged by static charges from fingers or tools. Hold the rom packs by the plastic holders.

Figure 1-2 shows a rom pack and the rom carrier. The individual rom packs are placed into the carrier, and the carrier is slid into the compartment of the 4041.

The rom carrier holds up to six rom packs. The individual rom packs specify a particular slot in the carrier where they

must be placed. Match the numbers on the rom packs with the numbers on the carrier.

To insert rom packs into the rom carrier, place the rom pack right side up over the desired slot and gently press the pack into position. The rom packs are keyed and will only go in one way. When properly inserted, the top of the rom pack should be flush with the top of the rom carrier. Be gentle.

Removing Rom Packs from the Rom Carrier

Figure 1-2 also shows the underside of the rom carrier. To remove rom packs from the carrier, turn the carrier over. Gently press the two indentations over the rom pack that must be removed; the rom pack will pop out of the carrier.

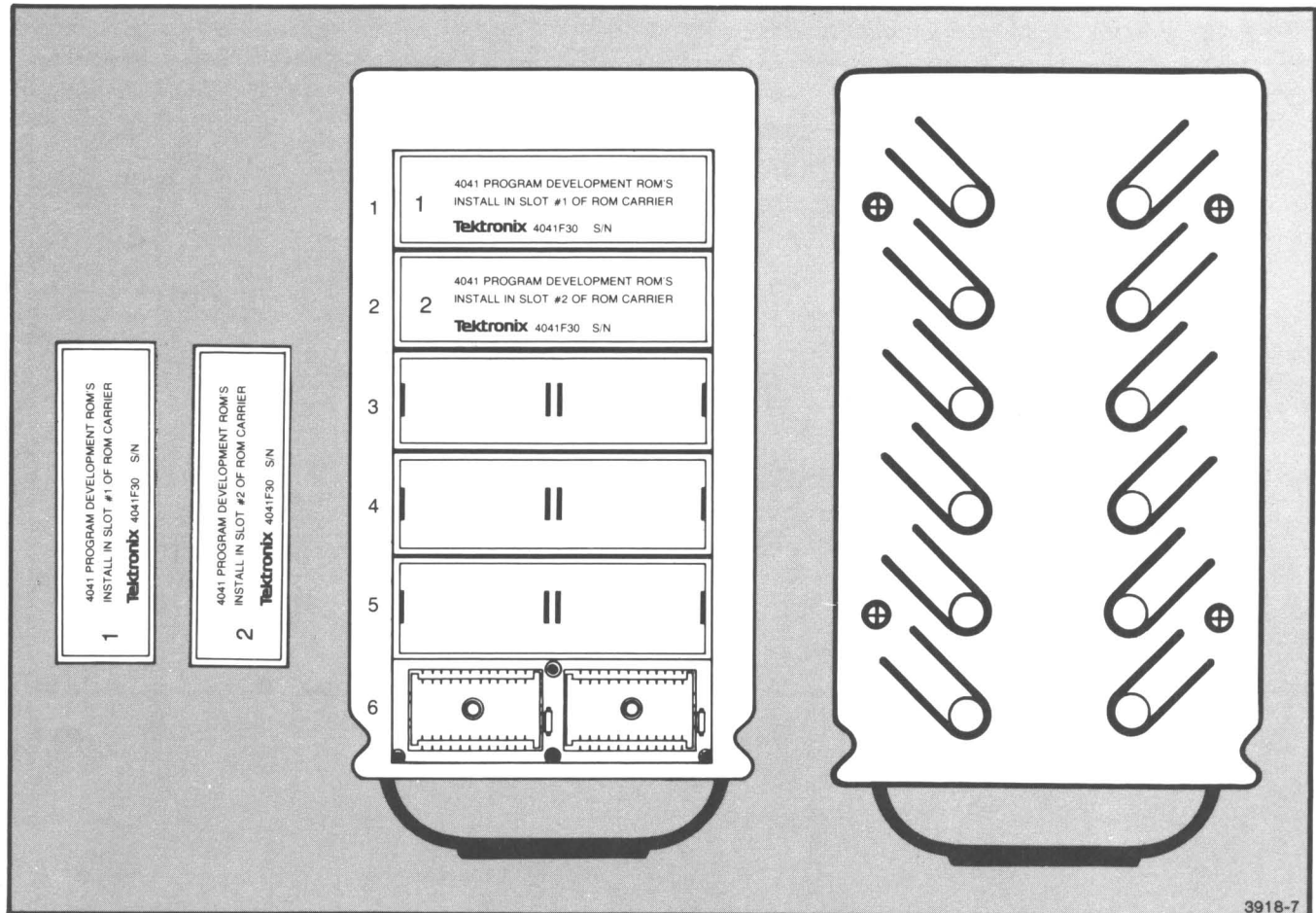

Figure 1-2. Rom Pack and Rom Carrier.

Putting the Rom Carrier Into the 4041

The rom carrier is placed in the compartment covered by the grill on the front panel of the 4041.



The 4041 power must be turned off before the rom carrier is installed. Inserting the rom carrier with the power on could cause power fluctuations that could damage the rom chips.

If the 4041's power is on, turn it off. Snap out the grill by prying at the coin slot at the top of the grill.

Slide the rom carrier into position in its compartment with the rom-pack-side up and the carrier handle last. Press the carrier firmly into place to securely seat the rom connectors. Make certain that the carrier is seated all the way in the compartment and is securely held in place.

Replace the front panel grill. The grill should easily snap back into place; if it does not, check that the rom carrier is inserted all the way. The grill's coin slot should be at the top.

Section 2 REPLACEABLE MECHANICAL PARTS

PARTS ORDERING INFORMATION

Replacement parts are available from or through your local Tektronix, Inc. Field Office or representative.

Changes to Tektronix instruments are sometimes made to accommodate improved components as they become available, and to give you the benefit of the latest circuit improvements developed in our engineering department. It is therefore important, when ordering parts, to include the following information in your order: Part number, instrument type or number, serial number, and modification number if applicable.

If a part you have ordered has been replaced with a new or improved part, your local Tektronix, Inc. Field Office or representative will contact you concerning any change in part number.

Change information, if any, is located at the rear of this manual.

SPECIAL NOTES AND SYMBOLS

X000 Part first added at this serial number
00X Part removed after this serial number

FIGURE AND INDEX NUMBERS

Items in this section are referenced by figure and index numbers to the illustrations.

INDENTATION SYSTEM

This mechanical parts list is indented to indicate item relationships. Following is an example of the indentation system used in the description column.

```

1 2 3 4 5           Name & Description
Assembly and/or Component
Attaching parts for Assembly and/or Component
    --- * ---
Detail Part of Assembly and/or Component
Attaching parts for Detail Part
    --- * ---
Parts of Detail Part
Attaching parts for Parts of Detail Part
    --- * ---
  
```

Attaching Parts always appear in the same indentation as the item it mounts, while the detail parts are indented to the right. Indented items are part of, and included with, the next higher indentation. The separation symbol --- * --- indicates the end of attaching parts.

Attaching parts must be purchased separately, unless otherwise specified.

ITEM NAME

In the Parts List, an Item Name is separated from the description by a colon (:). Because of space limitations, an Item Name may sometimes appear as incomplete. For further Item Name identification, the U.S. Federal Cataloging Handbook H6-1 can be utilized where possible.

ABBREVIATIONS

#	INCH	ELECTRN	ELECTRON	IN	INCH	SE	SINGLE END
ACTR	NUMBER SIZE	ELEC	ELECTRICAL	INCAND	INCANDESCENT	SECT	SECTION
ADPTR	ACTUATOR	ELCTLT	ELECTROLYTIC	INSUL	INSULATOR	SEMICON	SEMICONDUCTOR
ALIGN	ADAPTER	ELEM	ELEMENT	INTL	INTERNAL	SHLD	SHIELD
AL	ALIGNMENT	EPL	ELECTRICAL PARTS LIST	LPHLDR	LAMPHOLDER	SHLDR	SHOULDERED
ASSEM	ALUMINUM	EQPT	EQUIPMENT	MACH	MACHINE	SKT	SOCKET
ASSY	ASSEMBLED	EXT	EXTERNAL	MECH	MECHANICAL	SL	SLIDE
ATTEN	ASSEMBLY	FIL	FILLISTER HEAD	MTG	MOUNTING	SLFLKG	SELF-LOCKING
AWG	ATTENUATOR	FLEX	FLEXIBLE	NIP	NIPPLE	SLVNG	SLEEVEING
BD	AMERICAN WIRE GAGE	FLH	FLAT HEAD	NON WIRE	NOT WIRE WOUND	SPR	SPRING
BRKT	BOARD	FLTR	FILTER	OBD	ORDER BY DESCRIPTION	SQ	SQUARE
BRS	BRACKET	FR	FRAME or FRONT	OD	OUTSIDE DIAMETER	SST	STAINLESS STEEL
BRZ	BRASS	FSTNR	FASTENER	OVH	OVAL HEAD	STL	STEEL
BSHG	BRONZE	FT	FOOT	PH BRZ	PHOSPHOR BRONZE	SW	SWITCH
CAB	BUSHING	FXD	FIXED	PL	PLAIN or PLATE	T	TUBE
CAP	CABINET	GSKT	GASKET	PLSTC	PLASTIC	TERM	TERMINAL
CER	CAPACITOR	HDL	HANDLE	PN	PART NUMBER	THD	THREAD
CHAS	CERAMIC	HEX	HEXAGON	PNH	PAN HEAD	THK	THICK
CKT	CHASSIS	HEX HD	HEXAGONAL HEAD	PWR	POWER	TNSN	TENSION
COMP	CIRCUIT	HEX SOC	HEXAGONAL SOCKET	RCPT	RECEPTACLE	TPG	TAPPING
CONN	COMPOSITION	HLCP	HELICAL COMPRESSION	RES	RESISTOR	TRH	TRUSS HEAD
COV	CONNECTOR	HLEXT	HELICAL EXTENSION	RGD	RIGID	V	VOLTAGE
CPLG	COVER	HV	HIGH VOLTAGE	RLF	RELIEF	VAR	VARIABLE
CRT	COUPLING	IC	INTEGRATED CIRCUIT	RTNR	RETAINER	W/	WITH
DEG	CATHODE RAY TUBE	ID	INSIDE DIAMETER	SCH	SOCKET HEAD	WSHR	WASHER
DWR	DEGREE	IDENT	IDENTIFICATION	SCOPE	OSCILLOSCOPE	XFMR	TRANSFORMER
	DRAWER	IMPLR	IMPELLER	SCR	SCREW	XSTR	TRANSISTOR

REPLACEABLE MECHANICAL PARTS

CROSS INDEX—MFR. CODE NUMBER TO MANUFACTURER

Mfr. Code	Manufacturer	Address	City, State, Zip
80009	TEKTRONIX, INC.	P O BOX 500	BEAVERTON, OR 97077

REPLACEABLE MECHANICAL PARTS

Fig. & Index No.	Tektronix Part No.	Serial/Model No.		Qty	1 2 3 4 5	Name & Description	Mfr Code	Mfr Part Number
		Eff	Dscont					
1-1	119-1709-00	B010100	B019999	1		ROM CARRIER:W/ROM	80009	119-1709-00
	119-1709-01	B020000		1		ROM CARRIER:W/ROM	80009	119-1709-01
	-----			-		(U5;LOW NUMBERED SLOTS DESIGNATED UXX)		
	119-1710-00	B010100	B019999	1		ROM CARRIER:W/ROM	80009	119-1710-00
	119-1710-01	B020000		1		ROM CARRIER:W/ROM	80009	119-1710-01
	-----			-		(U10;HIGH NUMBERED SLOTS DESIGNATED UXXX)		
-2	105-08897-0			1		LCH BAR,CHIP CA:POLYPROPYLENE	80009	105-08897-00
-3	334-2602-00			1		MARKER,IDENT:4041 UTILITY ROM	80009	334-2602-00
STANDARD ACCESSORIES								
	070-4699-00			1		MANUAL,TECH:INSTRUCTION	80009	070-4699-00
	070-4700-00			1		MANUAL,TECH:REFERENCE	80009	070-4700-00

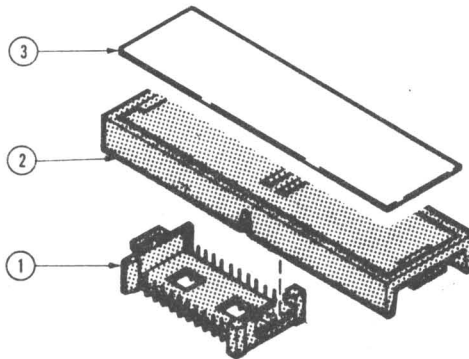

SECTION 3

ENGLISH ERROR MESSAGES

Whenever an error is detected, the 4041R04 Utilities Rom Pack appends a one-line English message that briefly describes the error to the standard error message that is returned.

An example of an error and the one line English message is as follows:

```
*Dir "Tape:"
*** ERROR # 842
Cartridge not in place
*
```

The user program can also obtain the English error message for any error by executing an "Errortxt" romcall.

The "Errortxt" romcall uses two parameters. The first parameter specifies the error number whose English error message is to be returned. The second parameter specifies the string variable into which the error message is to be returned.

If the error number passed does not match any of the standard error numbers, a null string is returned. Otherwise, the error message is returned in the string variable.

The error number passed must be in the range of an integer value (−32768 to +32767) or an error is generated.

The string returned by the romcall will have a maximum length of 128 characters or the dimensioned length of the string variable.

Example:

```
*ERRORTXT 812,Errstr$
*print errstr$
No listener on the bus.
```

The English error message associated with error 812 is returned in string variable Errstr\$.

SECTION 4

“RADIANS”, “DEGREES”, “GRADS”, AND “RCALLS” ROMCALLS

The following utility “Rcalls” are available to the user with the 4041R04 Utilities Rom:

- 1) RADIANS — sets the current trigonometric units to radians; equivalent to the SET ANGLE 0 statement.
- 2) DEGREES— sets the current trigonometric units to degrees; equivalent to the SET ANGLE 1 statement.
- 3) GRADS — sets the current trigonometric units to grads; equivalent to the SET ANGLE 2 statement.
- 4) RCALLS — lists all rompacks and romcalls available to the user on the system console device. Romcalls preceded by an asterisk (“*”) can be called without parameters.

The message returned by RCALLS designates parameterless romcalls by an asterisk (“*”). (A parameterless romcall is a romcall that can be executed by entering its name alone, without accompanying parameters.) These romcalls, when entered without parameters in immediate mode, always execute their function when the rompack to which they belong is installed. For example, typing the line

page

has different effects, depending on whether or not the 4041R01 Graphics Rompack is installed. If the Graphics rompack is not installed, typing “page” displays the value of the numeric variable named “page”. If the Graphics rompack is installed, typing “page” does not display the value of that variable; it clears the screen.

Note also that RCALLS displays the “invisible RCALL” form of the various romcalls. Thus, all romcalls that are longer than eight characters are shortened to exactly eight characters, and all romcalls that contain imbedded spaces have the spaces replaced by underscore characters.

The “RADIANS”, “DEGREES”, “GRADS”, and “RCALLS” romcalls take no parameters. If any are supplied, an error is generated.

Example:

Assuming a 4041 unit loaded with the Graphics and Utilities Roms, executing the program shown in Example 4-1 produces the output shown in Example 4-2.

```

100   A$="CURRENT TRIGONOMETRIC UNITS ARE "
110   RADIANS
120   Print a$;angle$(ask("angle"))
130   DEGREES
140   Print a$;angle$(ask("angle"))
150   GRADS
160   Print a$;angle$(ask("angle"))
180   RCALLS
190   End
300 Function angle$(x) local rad,deg,grad
310   Goto x+1 of rad,deg,grad
320 Rad:   angle$="RADIANS"
330   Return
340 Deg:   angle$="DEGREES"
350   Return
360 Grad:  angle$="GRADS"
370   Return
380   End
    
```

Example 4-1

“Radians”, “Degrees”, “Grads”, and “Rcalls” Romcalls

```
CURRENT TRIGONOMETRIC UNITS ARE RADIANS
CURRENT TRIGONOMETRIC UNITS ARE DEGREES
CURRENT TRIGONOMETRIC UNITS ARE GRADS
System Rcalls *=Immediate mode entry invokes function (does not display
                value of same-named variable, if one exists).

Rom=UTL1
    LOADROMS
    ERRORTXT
    * DEGREES
    * RADIANS
    * GRADS
    * RCALLS
    ROMCKSUM

Rom=GRPH
    MOVE
    DRAW
    * PAGE
    * HARDCOPY
    GTEXT
    RMOVE
    RDRAW
    * VIEWPORT
    * WINDOW
    * HOME
    GINIT
    ASK_LINE
    * COLOR
    ASK_COLO
    * LINSTYL
    ASK_WIND
    ASK_VIEW
    * TEXTSIZE
    ASK_TEXT
    GDEVICE
    POINTER
    GIN
```

Example 4-2

SECTION 5

INTERVAL/TIME OF DAY TIMER DEVICES

THE 4041R04 Utility Rompack provides three new I/O devices, named TIME0, TIME1, and TIME2, that can be individually set to interrupt 4041 BASIC program execution every n seconds or at a specified time of day.

Timer interrupts are performed by issuing a SET DRIVER statement and specifying an interval of time or a time of day. The timer device is then opened as a logical unit (with an OPEN statement), an SRQ handler is set up for the logical unit (with an ON SRQ statement), and then an SRQ is enabled for the logical unit opened (with an ENABLE SRQ statement).

Timer interrupts are set up by:

- 1) executing a SET DRIVER statement for the timer, specifying an interval of time or a time of day;
- 2) opening a logical unit for the timer device;
- 3) setting up an SRQ handler for the logical unit (using the ON SRQ statement);
- 4) enabling the SRQ interrupt for the timer device (using the ENABLE SRQ statement).

NOTE

While timer interrupts are set up using the ON SRQ and ENABLE SRQ statements, the devices do not affect the status of the GPIB's SRQ line.

Timer interrupts can be disabled at any time by means of the DISABLE SRQ statement, or can be reset with a new interval of time or time of day by means of a new SET DRIVER statement.

Each timer is independent of the others and may be set to interrupt at specified intervals or at any time of day.

Attempting to specify both an interval of time and a time of day within the same SET DRIVER statement results in an error.

If a timer has been enabled, it interrupts the BASIC program running when its interval of time or time of day is reached. If the timer has not been enabled, it simply increments the COUNT parameter and resets its interrupt condition.

Setting the Interval Timer: the INT Parameter

To set up a timer that will interrupt at intervals of time, execute a SET DRIVER statement specifying a value for the INT parameter.

For example, the following statement sets up device TIME0 to interrupt every 10 seconds:

```
Set driver "time0(int=10):"
```

The value specified by the INT parameter is the number of seconds, with a minimum of 1/100th of a second (10 milliseconds) and a maximum of $2^{31}-1$ seconds (about eight months).

Setting the Time-of-Day Timer: the TIM Parameter

To set up a timer that will interrupt at a given time of day, execute a SET DRIVER statement specifying a value for the TIM parameter.

For example, the following statement sets up device TIME1 to interrupt at 3:00 p.m. each day:

```
Set driver "time1(tim=""15:00"")"
```

Note the use of the double quotes to insert a quotation mark into the stream spec. Also note that the 4041 uses a 24-hour clock.

The time of day is any valid time of day specified in "hh:mm:ss".

NOTE

If a SET TIME statement is executed after a SET DRIVER statement that specifies a time-of-day, erroneous interrupt timing will occur. This is because the 4041 computes a difference between the time indicated by the TIM parameter and the current time in setting up the interrupt. Thus, if a SET TIME statement is executed, a new SET DRIVER statement setting up a time-of-day interrupt should also be executed.

Interval/Time-of-Day Timer Devices

Keeping Track of Timer Interrupts: the COU Parameter

Each timer begins its timing as soon as it is opened. If its interrupt condition occurs while it is disabled, the timer updates its COUnT parameter by 1, and resets its interrupt condition.

The current value of the COUnT parameter for a timer can be obtained by a BASIC program by executing an Ask\$("LU",n) function, where "n" is the logical unit number for the desired timer.

The value of the COU parameter tells how many interrupts have been "missed" while the timer was disabled (e.g., while it was servicing a previous interrupt, or after the logical unit was opened but before the interrupt condition was enabled).

For example, the following results of Ask\$("lu",n) functions:

```
TIME0(INT=1.00000E+1,TIM="",COU=4.00000E+0);  
TIME1(INT=0.00000E+0,TIM="10:24:45",COU=1.00000E+0);
```

indicate that four interrupts have been missed since Timer 0 was opened or last serviced, and that one interrupt has been missed since Timer 1 was opened or last serviced.

Example:

```
100 !  
110 !Set up two timers for BASIC program interrupts  
120 !  
130 Set driver "Time0(Interval=10.0):" !Interrupt every 10 seconds  
140 Set driver "Time1(Time=""14:22:12""): " !Interrupt at 14:22:12  
150 Open #1:"Time0:" !Open a logical unit for timer 0  
160 Open #2:"Time1:" !Open a logical unit for timer 1  
170 On Srq(1) then call Tensec !Set up interrupt handler for Time0  
180 On Srq(2) then call Wake_up !Set up interrupt handler for Time1  
190 Enable Srq(1),Srq(2) !Enable both Timers to interrupt  
:  
:  
500 Sub Tensec ! This routine is executed every ten seconds  
510 Print "Ten seconds have expired"  
520 Resume  
530 End  
600 Sub Wake_up  
610 Print "It is now 14:22:12" !Print current time of day  
620 Set driver "Time1(Time=""15:45:55""): " !New time of day interrupt  
630 Resume  
640 End
```

SECTION 6

SOFT ROMPACK LOADER

The soft rompack loader capability provided by the 4041R04 Utility Rompack to load rompacks from a device (such as a tape) into random access memory. Once the rompacks are loaded, they become available to the user, just as if they were loaded in the rom carrier.

Since the 4041 has a limited number of rom carrier slots, this method of adding rompacks increases the number of rompacks that a user may have on a single 4041. The trade-off for using this method is that some memory that would otherwise be available for user programs or data must be used to accommodate the rompack.

The method of loading rompacks is by means of the "Loadroms" romcall. This romcall takes as an argument the stream specification of a file to be loaded into memory; thus, the statement

```
Loadroms "nerp", "foo"
```

loads files "nerp", and "foo" from the SYSDEV device into memory, whereupon the corresponding rompacks become available to the user.

All soft rompack files are created by Tektronix and can be obtained by users who have the 4041R04 Utility Rompack.

When soft rompacks are loaded, the 4041 checks to make sure that at least 1024 bytes of user memory remain for programs and data. If loading the rompack would leave less than 1024 bytes of memory available, an error is generated.

Attempting to load a rompack that is already in the system results in an error.

SECTION 7

PROM FILE SYSTEM

The 4041R04 Utility Rompack's PROM file system provides a new I/O device that reads files from PROMs. The advantage to using this new I/O device is that files can be read considerably faster from PROMs than from other I/O devices, because no mechanical movement (as of tape or disks past read/write heads) is required.

The PROM file system allows the user to open or close files, read data or program lines from PROMs, execute the TYPE function on PROM-resident files, issue a directory request for device PROM0, and set PROM0 as the "SYSDEV" device.

PROM0 file parameters include the data format (ASCII or ITEM) and the EOM, EOH, EOA, and EOU characters. File names for PROM files can be up to 6 characters in length. The number of files is limited only by the PROM space available in the 4041. An example of a PROM directory is as follows:

File	Type	Size	Creation Date
AUTOLD	AS	1215	16-DEC-82 13:41:37
BACKUP	AS	1728	16-DEC-82 13:44:23
SQUISH	AS	2537	16-DEC-82 13:48:54
NEWRT	IT	3959	16-DEC-82 14:03:34

When the 4041 is powered up, it searches the rom carrier for a file or files stored in a PROM. If one is found, device PROM0 becomes a valid driver in the I/O system. In addition, if an "AUTOLD" file is found during this search, device PROM0 becomes the default SYSDEV device.

In addition, if an "AUTOLD" file is found during this search, device PROM0 becomes the default SYSDEV device. This allows a 4041 equipped with PROMs to be powered-on in the exact configuration desired, without the need for operator intervention (such as loading a tape or running an initialization program), since the PROM's "AUTOLD" file will be loaded and executed automatically at power-up.

Building PROM Files

Any user can create PROM files using the 4041 BASIC utility program "PRMBLD". This program prompts the user for all files residing on a DC-100 tape that are to be included in a set(s) of PROMs. The files are read and an "image" of the roms is built and saved on a DC-100 tape.

Once the rom image is saved, it can be transferred to the PROM(s) from tape using the 4041 BASIC Utility program "RMXFER".

Once the PROMs are programmed, they can be placed in any 4041 slot pair for future access by the PROM file system.

The PRMBLD and RMXFER programs are part of an optional accessory package that supports user-created PROM packs. Documentation included with that package gives complete details for use of these programs.

APPENDIX A

ERROR MESSAGES

1) ROMCALL ERRORS

These errors are detected when romcalls are executed. The error numbers shown have the rompack error base (which depends on the Utility rompack's slot position in the rom carrier) added to them when they are displayed.

- 1 = The "Loadroms" rcall was made without any parameters passed.
- 2 = The file ID field for a soft rompack file was incorrect. All soft rompack files created by Tektronix have a unique ID record, thus the file specified is either not a soft rompack or the first record is being read incorrect
- 3 = Insufficient memory space to load the specified soft rompack(s). An attempt has been made to load one or more soft rompacks that will consume too much of the available memory.
- 4 = Bad record detected while loading a soft rompack.
- 5 = Parameters passed for a romcall were incorrect or in the wrong order.
- 6 = Attempt to pass parameters for a romcall when none were expected.
- 7 = Attempt to load a rompack that is already present in the system, OR more than one stream-spec specified the same soft rompack.
- 8 = String passed for checksum was in error. The string passed for the checksum calculation was either not defined, less than 6 characters long, or was an odd length.

2) TIMER DEVICE ERRORS

- 1010 = Invalid timer request. An illegal I/O request was specified for the timer device.

- 1011 = Open request, with different LUN, while timer already open. An attempt was made to open a timer device while it was already open with a different logical unit.
- 1012 = Cannot specify both interval and time of day interrupt. A set driver for a timer device was made with both an interval of time delay and a time of day interrupt specified.
- 1013 = No interval value specified for a timer device. A set driver request was made with no interval setting specified or the value specified was rounded to zero.
- 1014 = Invalid time of day specified for time of day interrupt. The time of day specified was not in the range of 00:00:00 and 23:59:59.
- 1015 = Invalid interval of time specified for timer interrupt. The interval of time specified in a set driver was greater than 21,474,833 seconds.

3) PROM FILE DEVICE ERRORS

- 1030 = Illegal command request for the PROM device. An illegal I/O request was specified for the PROM device.
- 1031 = File specified in an OPEN statement could not be found.
- 1032 = File type specified in an OPEN statement was incorrect. An attempt was made to open an ASCII file with a format of ITEM or an ITEM file with a format of ASCII.
- 1033 = End of file detected. An input request was issued and end of file was detected.

APPENDIX B

SYNTAX AND DESCRIPTIVE FORMS

Syntax and Descriptive Forms:

```
[[line-no.] {RCALL "DEGREES"}
{DEGREES}
```

Syntax Form:

```
[[line-no.] {RCALL "ERRORTXT",} numexp, strvar
{ERRORTXT }
```

Descriptive Form:

```
[[line-no.] {RCALL "ERRORTXT",} error-number, English-error-message
{ERRORTXT }
```

Syntax and Descriptive Forms:

```
[[line-no.] {RCALL "GRADS"}
{GRADS}
```

Syntax Form:

```
[[line-no.] {RCALL "LOADROMS",} strexp[, strexp...]
{LOADROMS }
```

Descriptive Form:

```
[[line-no.] {RCALL "LOADROMS",} stream-spec[, stream-spec...]
{LOADROMS }
```

Syntax and Descriptive Forms:

```
[[line-no.] {RCALL "RADIANS"}
{RADIANS}
```

Syntax and Descriptive Forms:

```
[[line-no.] {RCALL "RCALLS"}
{RCALLS}
```

INDEX

COU Parameter, 5-2

DEGREES Romcall, 4-1

English Error Messages, 3-1

ERRORTXT Romcall, 3-1

GRADS Romcall, 4-1

INT Parameter, 5-1

Interval Timer Interrupts, 5-1

LOADROMS Romcall, 6-1

PROM File System, 7-1

PROM0 Device, 7-1

RADIANS Romcall, 4-1

Setting Up Timer Interrupts, 5-1

TIM Parameter, 5-1

TIME0 Device, 5-1

TIME1 Device, 5-1

Time-of-Day Timer Interrupts, 5-1