

ramtek

**System
Description
Manual**

**RM-9000
Graphic
Display
System**

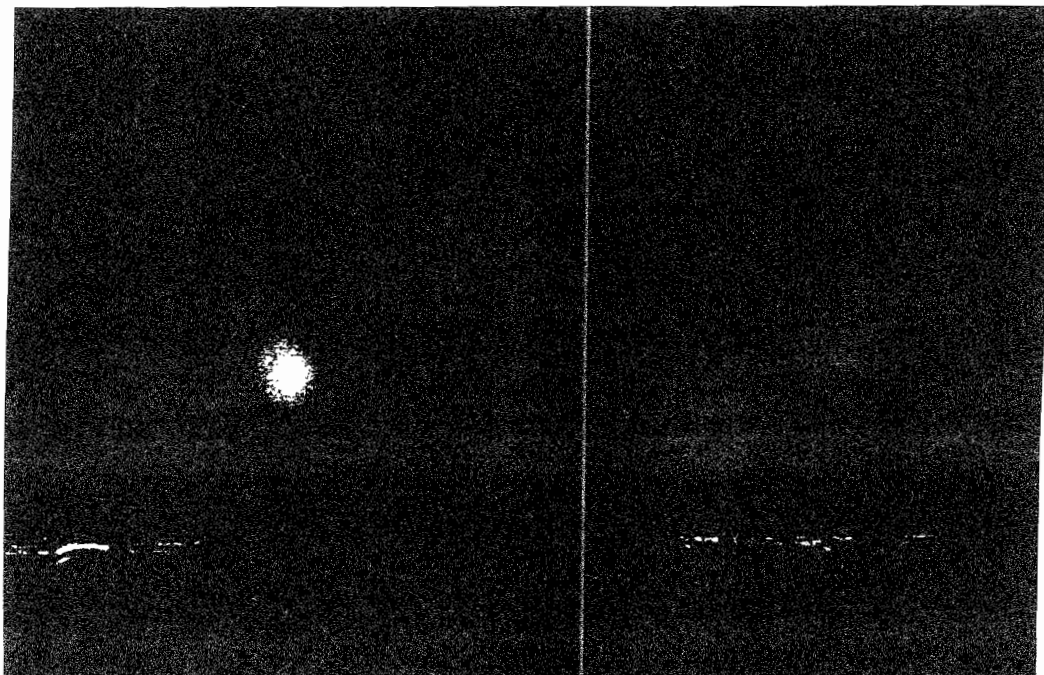



9000 SERIES GRAPHIC DISPLAY SYSTEM

SYSTEM DESCRIPTION MANUAL

RAMTEK CORPORATION
585 North Mary, Sunnyvale, CA 94086

Reprinted November 1977

CONTENTS

Section	Page
I. GENERAL INFORMATION	1-1
1-1 Introduction	1-1
1-2 Functional Description	1-3
II. SPECIFICATIONS	2-1
2-1 Functional Specifications	2-1
2-2 Programming Specifications	2-9
2-3 Physical Specifications	2-13
2-4 Environmental Specifications	2-13
2-5 Power Requirements	2-14
III. PERIPHERAL OPTIONS	3-1
3-1 Introduction	3-1
3-2 Cursor Description	3-1
3-3 Joystick Cursor Controller GC-106	3-1
3-4 Joystick Operation	3-3
3-5 Status Switch Operation	3-4
3-6 Channel Select Switches	3-5
3-7 Trackball - GC-104	3-5
3-8 Process Control Keyboard - GC-104	3-6

SECTION I GENERAL INFORMATION

1-1 INTRODUCTION

The Model RM-9100, 9200 and 9300 Raster Scan Graphic Display Systems are members of a compatible family of solid-state, digital television image generation systems which functionally differ only in spatial resolution. The key features are described as follows:

COMPATIBILITY

Each model is functionally identical and interprets an identical instruction set. Each is capable of generating multiple black and white (B/W), grey scale and/or color images which may be viewed upon commercially available television monitors.

MODULARITY

Modular design dictated system architecture in both hardware and firmware. The user need purchase only those features which are applicable for generating his particular display(s).

EXPANDABILITY

The modular architecture greatly simplifies field expansion of the system. Most options are plug-in modules and are easily installed. System obsolescence, because of new or modified requirements, is eliminated because systematic upgrading of the display system can occur as requirements change or grow. Expansion from B/W to grey scale or color, or to additional grey scale levels or Likewise, the various firmware options (graphics, etc.) may be installed.

FLEXIBILITY

The system was designed to fit the majority of applications with a basic model tailored by user selected off-the-shelf options. Received instructions are interpreted by a programmable microprocessor. The host computer/microprocessor interface to the frame buffer's refresh memory is at the pixel level. The frame buffer stores up to twelve bits per pixel and may be partitioned into multiple independent channels. Optional function tables provide for programmable definition of output intensity and/or color and priority. Cursor and overlay/underlay mixing is accomplished via PROM lookup, and the user may specify the PROM. All output signals are composite video. Where required, external

synchronization is achieved via an optional phase-locked loop. A variety of interactive peripherals are available and these are interfaced via the Display System and its microprocessor.

PROGRAMMABILITY

One of the greatest advantages of the system is the power of its instruction set. While a machine level capability is provided for diagnostic purposes, most user oriented instructions resemble typical compiler level statements. Because the language itself dictated hardware design, the system has been appropriately optimized. Because host communication is typically at a high level, programming costs are minimized while system throughput is maximized.

ADAPTABILITY

Because the instruction set is defined in firmware, the system is extraordinarily adaptable to specific applications requirements. Ramtek provides a general purpose operating system (in firmware) which defines the instruction set that is interpreted by the Display System. By loading user-defined subroutines or reprogramming this firmware, the user may augment, modify or completely redefine the instruction set of the Display System. For example, a special purpose (versus general purpose) instruction set and operating system might be developed by a user with very specific requirements. In this way throughput and overhead (in terms of local resources) could be optimized for a particular application. Because the microprocessor provides a source of local intelligence, the host computer and its interface can sometimes be eliminated altogether. For example, a mass storage device can be interfaced directly to the Display System and the firmware package can be reprogrammed to process this input versus the normal host generated graphic instructions. Control would typically be via a local keyboard and/or cursor controller, both of which can be provided by Ramtek. In this way, the system could be operated as a cost-effective "stand alone" display station. In addition to the Display System itself, Ramtek produces an In-Line Circuit Emulator (Model MM80) which provides an efficient mechanism for assembly and checkout of customized software/firmware packages. Options for the MM80 include a single-pass assembler, debugger, disassembler, PROM simulator and PROM programmer. Because of its inherent capability, the MM80 also doubles as a powerful diagnostic tool. By replacing the microprocessor chip with an interface connector, the user is able to exercise and troubleshoot both system hardware and firmware.

RELIABILITY

Best commercial practices have been implemented. Except for a few low production computer interfaces, the entire system (including backplane) is implemented in printed circuit. Only reliable, multiple sourced components are used. A rigorous quality assurance program which includes high temperature burn-in of each system is used in order to isolate and replace infant component failures.

MAINTAINABILITY

Because of the solid-state nature of the system, no special preventive maintenance measures are required. A coast-to-coast field service organization is available to our customers. Engineering drawings, a recommended spares list and optional diagnostics (in PROM) are available to our OEM customers who are serious about performing their own maintenance. Both hardware and software training classes are periodically offered at our plant in Sunnyvale, California.

1-2 FUNCTIONAL DESCRIPTION

Figure 1-1 functionally illustrates the Model RM-9100, 9200 and 9300 Display Systems. Following is a brief description of each system component:

COMPUTER INTERFACE

The computer interface interconnects the host processor and Display System internal processor bus. Provides for high speed (up to 660 KHz), bidirectional, 16 bit parallel communication between the host computer and Display System. Also implements four external interrupts. Typically implements or uses DMA capability in the host processor.

INTERNAL PROCESSOR BUS

Interconnects the computer interface, display generator, video generator, display processor, memory option card, serial link/cursor option and floppy disk interface option. Provides for high speed device-to-device communication. Implements nonprocessor DMA.

DISPLAY GENERATOR

Interconnects the internal processor bus and refresh memory for image generation and retrieval. Except for two dimensional font, raster and graphics data, this communication is in the form of a 16 bit word per pixel, with up to 12 bits being written in the Z axis while X and Y increment as prescribed by internal registers and logic in the display processor and display generator. Optimizes the display

processor interface with respect to its internal algorithms for generating character and graphics data. Character and raster data is written as an 8 bit byte with each byte describing up to eight consecutive pixels along a given line, whether horizontal or vertical. Graphics data is written via commanded movement of the current operating point, such as up or down and/or left or right. For font, raster and graphics data, color or intensity (Z axis) is assigned via specific registers which specify foreground and background color or intensity. Foreground/background reversal and writing mode (replacement versus additive) are specified via independent bits within a control register.

REFRESH MEMORY

The refresh memory interconnects the display generator and video generator and provides from 1-12 bits of storage for each picture element. Vertical resolution is 240, 256, 480 or 512 lines. Horizontal resolution is 320 or 640 elements. Access time is 1.5 μ s/pixel.

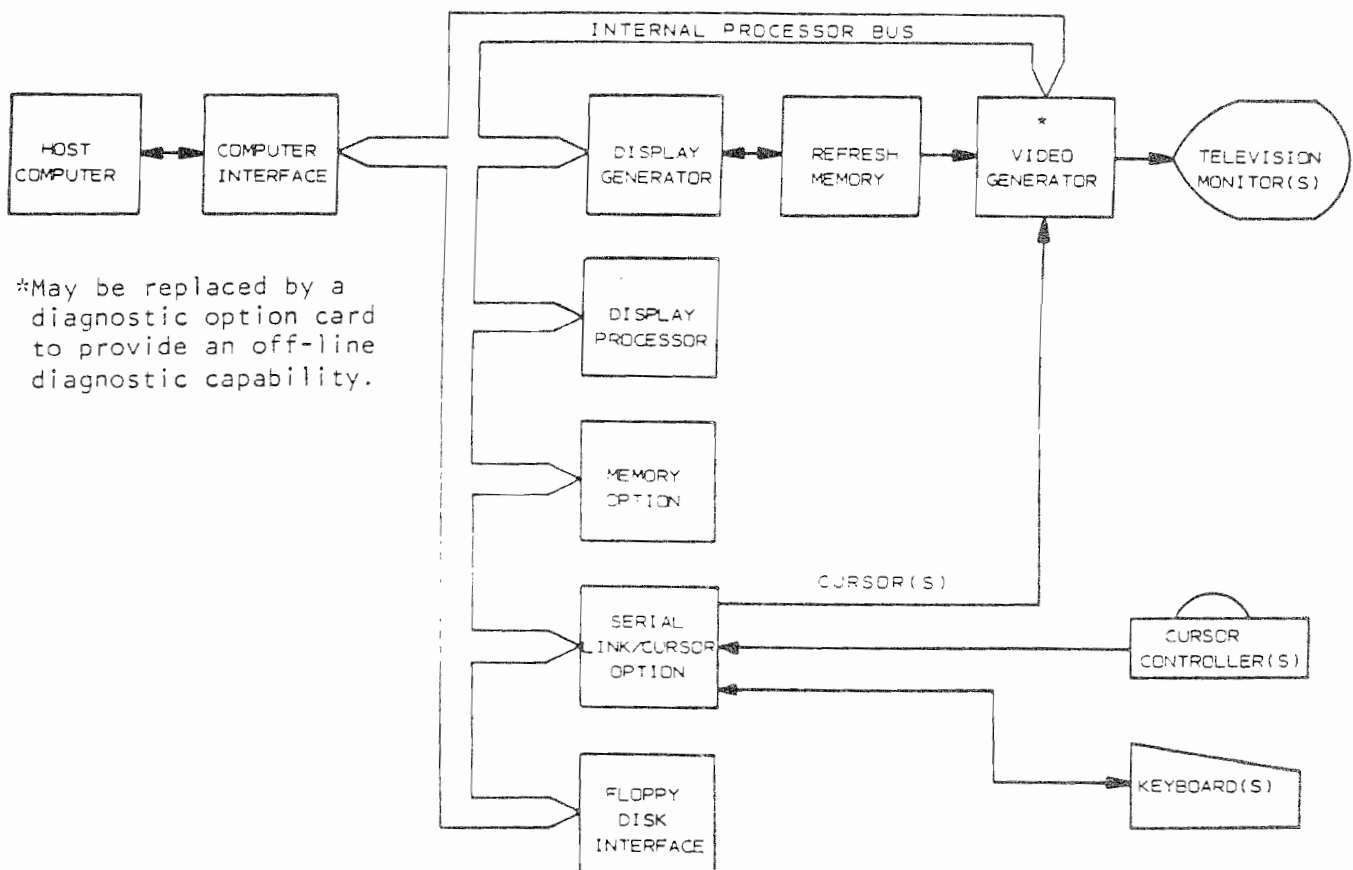

FIGURE 1-1. RM-9100, 9200, and 9300 Functional Block Diagram

VIDEO GENERATOR

Interconnects the refresh memories, cursor generators and television monitors. Mixes stored image, overlay and cursor data and generates RS-170 compatible composite video signals. Following is a description of the three basic video boards:

- a. RM-V1. Figure 1-2 functionally illustrates the RM-V1 video board which provides for 12 B/W channels, four 7 color (RGB) channels, three 16 level grey scale channels, one 256 level grey scale channel or one 4,096 color (RGB) channel. Includes 12 direct outputs plus three 4 bit DACs (or one 8 bit and one 4 bit DAC), four cursor channels and two overlay channels.

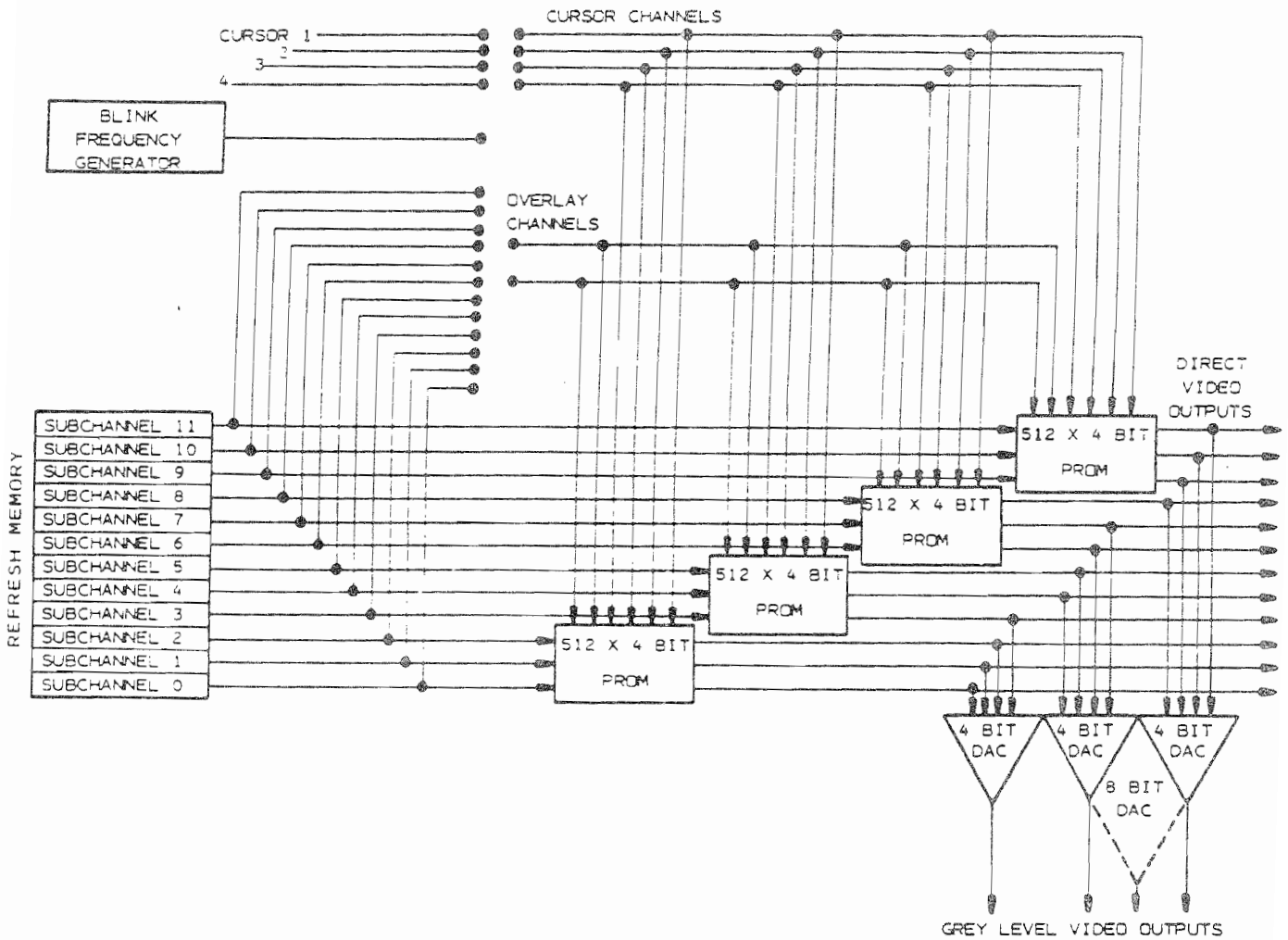

FIGURE 1-2. RM-V1 Functional Block Diagram

- b. RM-V2. Figure 1-3 functionally illustrates the RM-V2 video board which provides for host programmable pseudo color or grey scale translation to any of 4,096 colors or 256 grey scale levels. Includes one 1,024 word x 12 bit programmable function memory plus three 4 bit DACs, one 8 bit DAC (assignable before or after the function memory), two cursor channels and two overlay channels.

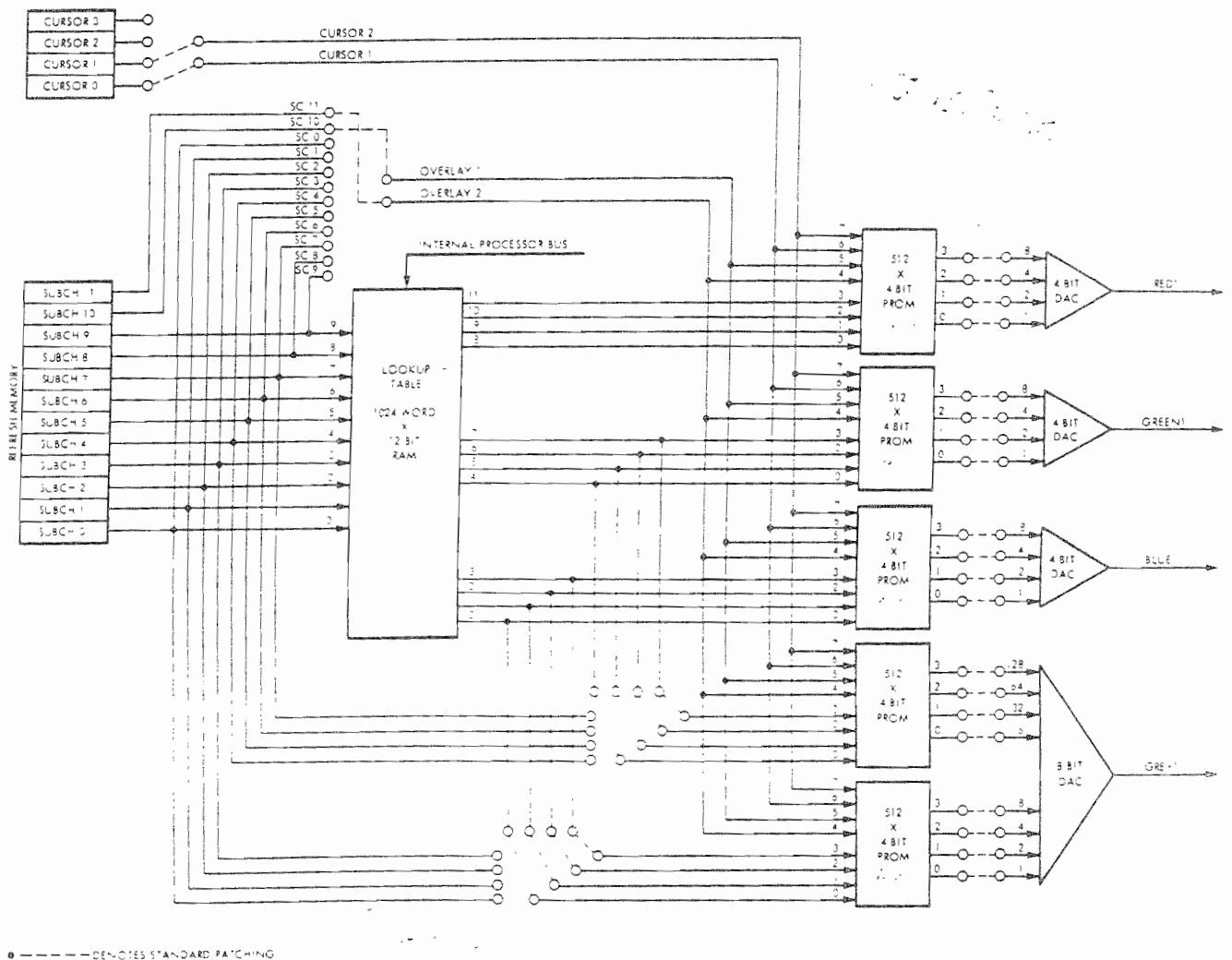

FIGURE 1-3. RM-V2 Functional Block Diagram

c. RM-V3. Figure 1-4 functionally illustrates the RM-V3 video board which provides automatic image density slicing per external specification of window center and range. Simultaneously generates any 32 of 256 customer specified colors (RGB) and grey scale levels, typically gamma corrected. Includes an 8080 microprocessor with associated RAM and ROM memory and a parallel interface for window specification, plus one 1,024 word x 5 bit dynamic function memory, two fixed 32 word x 8 bit function memories, one 8 bit DAC (for grey scale), two 3 bit DACs (for red and green) and one 2 bit DAC (for blue).

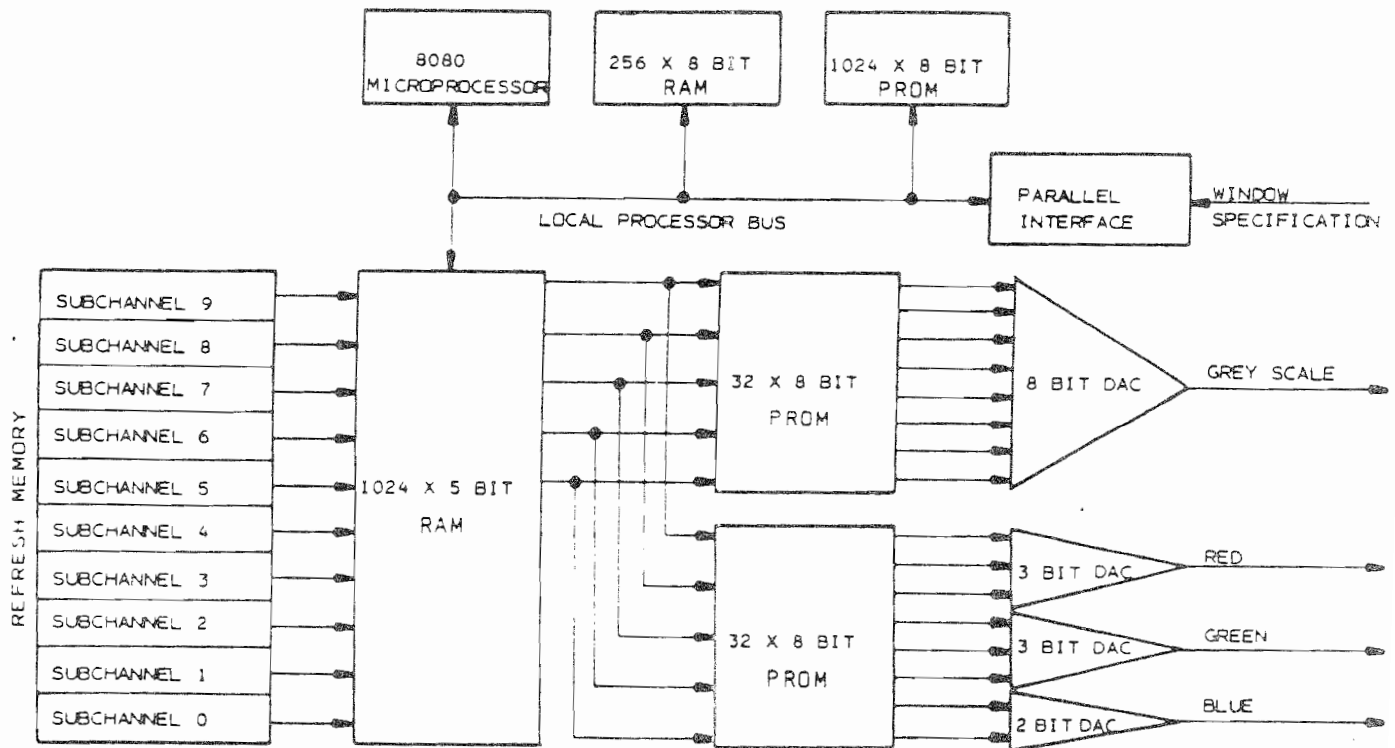

FIGURE 1-4. RM-V3 Functional Block Diagram

- d. RM-V6. Figure 1-5 functionally illustrates the RM-V6 video card which provides for two RGB video channels, each with up to 64 colors and an associated (but independent) multi-level, hard-copy output. Because video color and hard-copy intensity are assigned via customer-specified PROM lookup tables which are addressed by up to 6 refresh planes, cursor, and blink frequency, the user may define video and hard-copy output in terms of color and/or intensity for image, overlay, cursor and blink phase. e.g.: Given 4 refresh planes, the user might define 6 colors (including black) with dual intensity plus hardware blink from half to full intensity. The card processes up to 12 refresh planes into two 256 word x 8 bit PROM lookup tables, and includes two cursor channels, one blink frequency generator, and eight 2 bit digital-to-analog summing networks.

TELEVISION MONITOR

The television monitor(s) decodes the generated composite video signal(s) and displays the image by driving one or more cathode ray beams in raster fashion. The beams, when energized, excite phosphors painted upon the inner face of its picture tube. Tube refresh time is typically at 30 or 60 Hz.

DISPLAY PROCESSOR

Interprets command information and presides over the internal processor bus. Secondary functions include character generation and raster margining. Includes an 8080 microprocessor with 512 bytes of RAM and 2,048 bytes of ROM memory. Implements a basic instruction set which provides for imaging and text generation functions. Also optimizes function memory interface.

MEMORY OPTION CARD

Expands display processor internal memory by 8,192 bytes of RAM and implements an internal DMA adaptability. Also provides for an additional 14,336 bytes of PROM memory. Enables implementation of the following options:

- a. RM-GRA (graphic option). Generates end-point vectors, conics, plots and bar charts. Also writes raster data.
- b. RM-SCA (scaling option). Scales image and font data to a maximum ratio of 4:1 or 1:4.
- c. RM-LAF (logical and arithmetic functions option). Provides read-modify write functions for interactive processing of two images.
- d. RM-SCR (scroll option). Provides independent subchannel and windowed scroll.

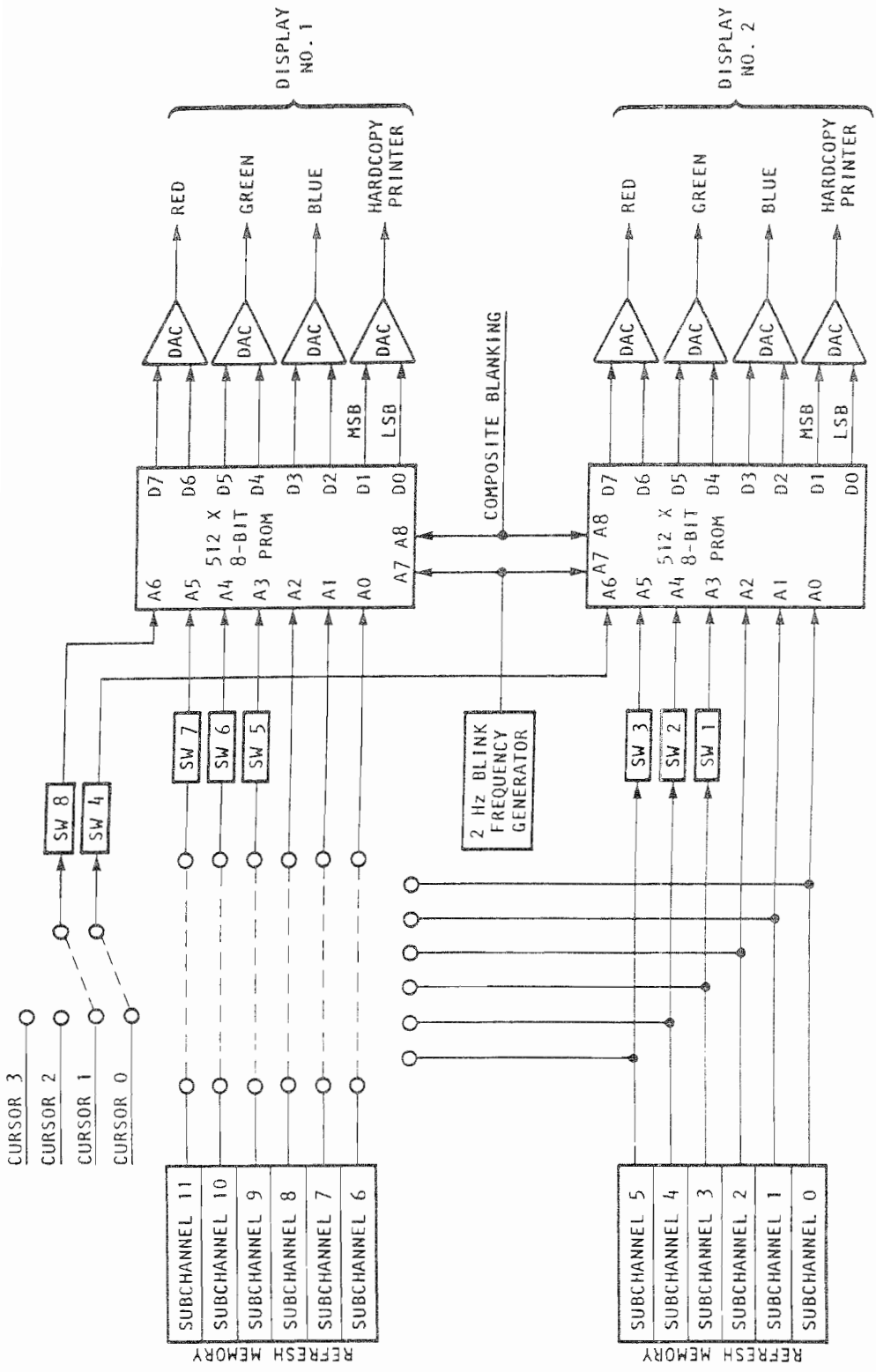

- SW 1, SW2, ETC, ARE 3-POSITION SWITCHES SELECTING EITHER LOGIC 0, LOGIC 1, OR DATA.
- - - - - - DENOTES STANDARD PATCHING.

FIGURE 1-5. Type 6 Video Generator for RM-9X00

- e. RM-STA (status management option). Provides programmable stack for temporary storage and subsequent retrieval of Display System status.
- f. RM-FNT (programmable font option). Provides for host definition of up to 128 characters. Font dimension and content is programmable up to a maximum of 8 elements by 12 lines.
- g. RM-SBR (user subroutine option). Provides a writable control store feature by enabling the host computer to load, retrieve and call (for execution) user-defined subroutines within the Display System. When called, these subroutines assume total system control, thereby enabling the user to define his own specific command set or graphic procedures. These subroutines are in the form of standard 8080 microprocessor object code and are called via a specific command. When complete, exit (to the Ramtek defined operating system) is effected by executing the 8080 Return (RET) instruction.
- h. RM-PER (interactive peripherals option). Provides interfacing logic for four keyboards, joysticks (or trackballs) and cursor generators.

SERIAL LINK/CURSOR OPTION

Provides two keyboard interfaces, two joystick (or trackball) interfaces with cursor steering logic, and two non-destructive cursor generators. If required, the cursor controller ports may be converted to keyboard ports. Thus, up to four keyboards may be interfaced to each serial link/cursor card. Each system controller provides for a maximum of two serial link/cursor cards.

FLOPPY DISC INTERFACE

Provides interface for a single floppy disc drive. This option is possible via addition of logic to the extended memory option board.

PROCESS CONTROL KEYBOARD

General purpose keyboard with 61 key alphanumeric set, 16 lighted function keys, 12 cursor control or special function keys and 12 numeric keys. Features two key rollover/n key lockout, auto repeat (10 Hz) and TTY mode.

CURSOR CONTROLLER

Rate controlled joystick or trackball controls cursor state (on, off, blink) and position. May be switch programmed to interrupt host computer upon operator demand, or whenever cursor position changes.

DIAGNOSTIC OPTION CARD

The diagnostic option card (RM-DOC) provides an off-line fault detection/isolation capability for the RM-9100, 9200 and 9300 display systems. When inserted into a

video generator card slot, the card enables various diagnostic test programs to be selected and executed via an interconnecting special function keyboard which is supplied as a part of the option. The results of the diagnostic tests are displayed on the television monitor(s). Wherever possible, these tests identify failing components or logic circuits. The option includes the logic card with additional PROM and RAM memory, a B/W video generator capable of displaying any subchannel, additional PROM and RAM memory with stored diagnostic firmware, and a 25-key special function keyboard.

SECTION II SPECIFICATIONS

2-1 FUNCTIONAL SPECIFICATIONS

The following data functionally specifies the Model RM-9100, 9200 and 9300 Graphic Display Systems:

REFRESH TECHNIQUE

The refresh technique employed is that of a classical raster scan display generator in that the generated image is stored in a frame buffer which is continuously scanned at the television raster rate.

FRAME BUFFER

The frame buffer stores up to 12 bits per picture element (pixel). Each bit is stored in a separate refresh memory plane. Any combination of the 12 possible planes may be accessed and written simultaneously. The individual planes may be utilized as multiple independent display channels.

RESOLUTION AND LINE RATES

Six possible selections of resolution are available. Table 2-1 lists the available resolutions and their associated television line rates. Note that a repeat field scan pattern (50 or 60 Hz refresh) is typically employed for the Model RM-9100 and 9200 Display Systems. This is done to eliminate flicker, caused by the fast decay rate of standard CRT phosphors. The Model RM-9300 requires a 25 or 30 Hz refresh frequency and a 2:1 interlaced scan pattern. Here, all even numbered lines (field A) are refreshed, then odd numbered lines (field B) are refreshed. Although somewhat complicated, this is done in order to minimize flicker.

REFRESH MEMORY

The refresh memory consists of 4K MOS dynamic RAMs. Each memory board stores up to six RM-9100 frames, three RM-9200 frames or three RM-9300 fields. Separate RM-9300 fields reside on separate memory boards. Access to any 12 bit cell of refresh memory is in 1.5 μ s. Refresh memory access is interleaved such that write cycles do not interfere with refresh read cycles and thus screen refresh.

DISPLAY PROCESSOR

The display processor consists of an 8080 microprocessor with 2,048 bytes of program memory (PROM) and 512 bytes of scratch pad memory (RAM). Instruction cycle time is approximately 350 ns. Higher frequency oscillators may be used and retrofitted as faster 8080 microprocessors become available.

TABLE 2-1. RM-9100, 9200, and 9300
Resolution and Line Rates

Model	Visible Elements	Visible Lines	Television Line Rate	Refresh Rate, Hz
RM-9100	320	240	524R	60
			525I	30
		256	558R	60
			559I	30
			624R	50
			625I	25
RM-9200	640	240	524R	60
			525I	30
		256	558R	60
			559I	30
			624R	50
			625I	25
RM-9300	640	480	525I	30
		512	559I	30
			625I	25

LEGEND: R = Repeat Field (50/60-Hz Refresh)
I = Interlace (25/30-Hz Refresh)

MEMORY EXPANSION

The 8080 microprocessor program memory may be expanded to 16,384 bytes and its scratch pad memory to 8,704 bytes via the addition of a plug-in memory option board, RM-MOC. This option also provides a microprocessor memory DMA capability.

INSTRUCTION DECODING

Instruction decoding is performed by the 8080 microprocessor. Because all instruction processing algorithms are permanently resident in firmware, the host processor is not required to determine the need for and load an appropriate algorithm for generation of particular graphic entities.

INSTRUCTION LEVEL

The most used instructions resemble typical compiler level statements. A machine level instruction set is also provided for diagnostic purposes, and for extremely sophisticated users who demand flexibility beyond that which is offered by the general purpose user oriented instruction set.

OPTIONAL INSTRUCTIONS AND ARGUMENTS

Firmware which implements a variety of optional instructions and arguments to existing instructions is available in PROM form. These PROMs may be installed in the field. Upon initialization, the basic firmware package recognizes the existence of each option and builds an appropriate vector table for quick decoding of all commands.

USER DEFINED COMMANDS

The instruction processing algorithms may be reprogrammed to augment, modify or completely replace the existing instruction set. Ramtek manufactures an 8080 In-Line Circuit Emulator, the Model MM80, to simplify this task.

BASIC CAPABILITY

In addition to a variety of generalized support functions, the basic firmware specifically supports image processing and character generation.

OPTIONAL CAPABILITY

Optional capability includes a graphics generator, scaling option, logical and arithmetic imaging functions, windowed and partitioned scroll option, status management option, programmable font option and interactive peripherals option.

IMAGING CAPABILITY

The basic system processes and stores up to 12 bits of three dimensional, digitized image data. The image data is received in an industry compatible word-per-pixel and bit-per-plane format, and is normally written directly into the refresh memory at rates of up to 660,000 pixels per second. During the time that image data is being received into refresh memory, the microprocessor serves only to perform the raster margining function (start a new line when the previous line is completed). Bit plane selection and pixel-to-pixel addressing is achieved in hardware. The image data is written into a prescribed rectangular area (or page) of refresh memory. Any of eight possible scan sequences may be selected, left-to-right/top-to-bottom, for example. The scaling option (RM-SCA) provides for up/down scaling of image data. When downward scaling is specified, average pixel values are computed and stored versus storing each n th pixel of each n th line, where n

represents the scaling ratio. When upward scaling is specified, each pixel is repeated n times on n lines. The logical and arithmetic functions option (RM-LAF) provides a mechanism for correlating separate images. For example, two images might be compared by subtracting one from the other. This is achieved by merely specifying an appropriate logical/arithmetic function when writing the second image to the display, and is implemented in firmware as a read-modify-write operation. As an example, the issued pixel might be subtracted from the corresponding stored pixel, and the difference would be stored versus the issued pixel itself. The various video generators provide for grey scale, color, pseudo color, automatic density slicing and contrast enhancement, and gamma correction of image data.

ALPHANUMERIC CAPABILITY

The basic system includes a character generator which decodes 64 USASCII character codes and generates the appropriate dot matrix symbols. The standard font size is five pixels by seven pixels within a seven pixel by nine pixel matrix. Row and column spacing is preset to seven pixels by nine pixels but is programmable. Sequential characters may be written from left-to-right, right-to-left, top-to-bottom or bottom-to-top, and may be rotated in 90 degree increments. Automatic margining is implemented such that a new line (or page) is started whenever a designated window boundary (margin) is crossed. A new line (or page) is also started whenever the USASCII carriage return symbol is decoded. A programmable font option (RM-FNT) provides for user definition (in real time) of up to 128 characters. For these characters, the matrix size is programmable up to a maximum size of eight pixels by twelve pixels. Characters may be up/down scaled by the scaling option (RM-SCA).

GRAPHICS CAPABILITY

The optional graphics generator (RM-GRA) draws end-point vectors, conics, plots and bar charts, and writes bit-per-element raster data into the refresh memory.

DYNAMIC CAPABILITY

Any rectangular area, even a single pixel, may be selectively erased and/or updated without affecting any other information in refresh memory. Graphic entities such as characters or vectors may be erased by inverting the background (BK) and writing mode (AD) control bits and repeating the original command list.

READBACK CAPABILITY

The host computer may retrieve stored images from the frame buffer's refresh

memory. Except for the direction of the data being transferred, the process duplicates that used for writing image data into the memory. Image data is retrieved from a specified rectangular area (or page) of refresh memory in a word-per-pixel and bit-per-plane format.

SCROLL CAPABILITY

There are two forms of scroll available. The first is a standard feature and allows the programmer to designate a coordinate value as the logical origin of the television raster. The image thus moves up or down and left or right simultaneously, and within 16.7 ms field time. The scroll is nondestructive in that data moving from the screen scrolls to the opposite edge of the screen. The second form of scroll is implemented as a firmware option (RM-SCR) and provides both windowing and partitioning. That is, only data within a prescribed rectangular area (or page) is scrolled, and only a prescribed combination of refresh memory planes are affected. Thus, multiple channels are supported because an associated set of memories can be scrolled without affecting the memory planes associated with other channels. The feature also provides for scrolling of images such as trend data behind a fixed grid overlay. This form of scroll is destructive in that data scrolling from the window is lost while the deserted area of the window is filled with the background color. Scroll is up, down, left or right and by a prescribed number of pixels. Scroll speed varies depending upon window size.

INTERACTIVE CAPABILITY

In addition to the display generator itself, Ramtek manufactures a line of keyboards, joysticks and trackballs which complete the man-machine interface. Up to four keyboards and four joysticks or trackballs may be interfaced to each display controller. The interface itself is important because it is via the Display System's microprocessor. Thus the local intelligence of the display processor can be applied to the problem of simplifying the man-machine interface, and without unnecessarily burdening the host processor. At the same time, the host processor's configuration is minimized because a single input/output port provides for both the display generator and its interactive peripherals.

RS-170 COMPATIBILITY

All video outputs conform to EIA Standard RS-170. All outputs are composite video. By generating composite video, it is unnecessary to run synchronization cabling, thus saving substantial costs on long cable runs. Because the video signals are RS-170 compatible, a variety of hard copy units and large screen projectors can be added to the system.

B/W CAPABILITY

Each display controller may generate up to 12 independent B/W channels. If the system is to be upgraded to grey scale or color at some future date, this may be easily accomplished by the addition of plug-in refresh memory.

GREY SCALE CAPABILITY

Each display controller may generate up to 256 grey levels, or multiple independent channels of a lesser number of grey levels such as three independent channels producing 16 grey levels each.

COLOR CAPABILITY

Each display controller may generate up to 4,096 colors, or multiple independent channels having a lesser number of colors such as four independent channels having seven colors each.

CURSOR CAPABILITY

Each display controller is capable of generating up to four nondestructive, crosshair cursors which may be steered via a cursor controller (joystick or trackball) without host processor intervention. The cursor controller may interrupt the host processor either each time the cursor moves (TRACK mode) or only upon operator request (ENTER function), and the host computer may read or write cursor location and status. The cursor target element is blanked in order to provide for accurate cursor positioning.

OVERLAY CAPABILITY

The RM-V1 and RM-V2 Video Generators provide for two independent overlay channels. Overlay channels are independent refresh memory plane outputs which are mixed with data channel outputs in order to form a composite image output to a single television monitor. Thus, either may be modified without affecting the other.

CURSOR AND OVERLAY MIXING

Cursor, overlay and data channel outputs are mixed via PROM lookup. Thus, individual cursor and overlay color or intensity can be specified by the user, and changed as the user's requirements change. Because data channel outputs are also subjected to the PROM lookup, color priorities may be established. For example, red might be given priority over green.

PSEUDO COLOR AND GREY SCALE TRANSLATION

Pseudo color and grey scale translation is performed by the RM-V2 Video Generator's function table. The function table is a 1,024 word x 12 bit RAM video

lookup table which is loaded via the host computer, and indexed by up to 10 bits of refresh memory. As each pixel is scanned from refresh memory, the corresponding word is retrieved from the function table and passed to the cursor/overlay mixers and digital-to-analog converters. For color translation, each 12 bit word is divided into three 4 bit binary fractions which, from left to right, describe the relative intensity of the primary colors (red, green and blue). For grey scale translation, the least significant 8 bits are treated as a single binary fraction which describes the output grey level intensity.

AUTOMATIC DENSITY SLICING

Automatic density slicing (or grey level windowing) is performed by the RM-V3 Video Generator's microprocessor and dynamic function table. The microprocessor and dynamic function table. The microprocessor processes an input window specification and generates a corresponding linear ramp in its function table such that all pixels having less intensity than the minimum window value are translated to black, and all pixels having greater intensity than the maximum window value are translated to white. The remaining (or selected) pixel values are translated to their respective grey levels based upon the calculated ramp stored in the function table. The input specification is received in parallel binary format as two values representing window center and range. The function table is a 1,024 x 5 bit RAM. Thus, up to 10 bits of image data can be processed and translated to 32 grey levels and colors simultaneously.

GAMMA CORRECTION

The RM-V3 Video Generator includes a 32 word x 8 bit PROM lookup table which translates the linear output of the dynamic function table to a 32 of 256 gamma corrected grey level output. The user may specify the gamma correction function at the time of order. Otherwise, a standard gamma correction curve will be implemented. In any case, the gamma correction function can be modified at a later date by simply replacing the PROM.

COLOR TRACKING

The RM-V3 Video Generator includes a second 32 word x 8 bit PROM lookup table which simultaneously translates the linear output of the dynamic function table to a 32 of 256 color output. Although color is not a current requirement of many users, it offers the advantage of showing a high contrast difference between relatively minor intensity differences, and thus can be a valuable diagnostic tool. The user may specify the output colors at the time of order, or may elect to accept

a standard color repertoire. In either case, the color assignments may be changed at a later date by simply replacing the PROM.

EXTERNAL SYNCHRONIZATION

The RM-9300 System Controller may externally synchronize to either the domestic (525) or European (625) television line rates. This option provides for external mixing of live or recorded television signals.

INTERFACING

Table 2-2 lists the computer interfaces which have been developed by Ramtek. In addition, certain computer mainframe manufacturers have developed Ramtek interfaces. Most are 16 bit parallel, bidirectional interfaces which typically use or implement direct memory access (DMA) in the host processor. Although typically limited by the host processor, bandwidth is up to 1.5 million words/second.

TABLE 2-2. Computer Interfaces

Model No.	Description	Prerequisite	Max. Cable Length, ft
RM-9000-40	General-purpose interface board.	RM-9000.	CPU-dependent
RM-9000-53	Data General Nova 1200 bidirectional interface.	Standard Nova programmed I/O channel with optional 4192 general-purpose I/O connector installed plus terminator for last I/O device.	6
RM-9000-51	DEC PDP-11 series bidirectional interface to DR-11C.	DEC PDP-11 DR-11C I/O board.	10
RM-9000-52	DEC PDP-11 series bidirectional interface to DR-11B.	DEC PDP-11 DR-11B I/O board.	10
RM-9000-56	Interdata 70/80 series bidirectional interface to programmed I/O multiplexer bus or SELH.	Interdata multiplexer bus or SELH.	15
RM-9000-59	Univac AN/UUK-7 bidirectional interface to Navy Type B NTDS FAST digital data interface (0 V, -3V logic levels). Usually a DMA interface. See Mil-Std-1397 (ships).	Navy Type B NTDS FAST digital data interface (I/O controller).	150 ^{**}
RM-9000-62	HP 2000 series bidirectional interface to HP microcircuit boards.	Two each HP microcircuit I/F kits No. 12566B.	10
RM-9000-63	Texas Instruments 980 series bidirectional interface to programmed I/O channel.	Ramtek logic is wired on a TI logic board (P/N 8EX112) that is plugged into any standard I/O bus connector.	15
RM-9000-64	Varian 620 and 75 series bidirectional interface to buffered I/O controller board.	Varian (BI0C) buffered I/O controller board (P/N E2832) and priority interrupt module (PIH) Model 620/i-16.	15
RM-9000-65	Data General Nova and Eclipse bidirectional interface.	4192 internal cable in customer's CPU.	35
RM-9000-12	Xerox Sigma series computer Model 7902 extended device subcontroller unidirectional interface to video system only.	Xerox Model 7902 extended device subchannel.	10

^{**}Actual cable is not provided; Ramtek provides connectors only.

2-2 PROGRAMMING SPECIFICATIONS

Table 2-3 lists the instruction repertoire of the Model RM-9100, 9200 and 9300 Graphic Display Systems. There are two distinctive categories of instructions and a variety of instruction formats.

TABLE 2-3. RM-9100, 9200, and 9300 Instruction Summary

Instruction Name	Mnemonic	Description
LOAD REGISTER	LOAD	Directly loads a display generator machine register.
READ REGISTER	READ	Directly reads a display generator machine register.
WRITE AUXILIARY MEMORY	WAM	Writes data to an auxiliary memory device.
READ AUXILIARY MEMORY .	RAM	Reads data from an auxiliary memory device.
RESET	RESET	Initializes the programmable stack and font, clears all serial ports and interrupts, and presets all complex format instruction arguments to known values.
INITIALIZE	INIT	Presets all complex format instruction arguments to known values.
NO-OPERATION	NOP	Performs no operation whatsoever.
SET PARAMETER	SET	Sets one or more complex format instruction arguments.
ERASE	ERS	Erases a rectangular area (page) of refresh memory.
WRITE IMAGE	WI	Writes three dimensional image data into a rectangular area (page) of the refresh memory.
READ IMAGE	RI	Retrieves three dimensional image data from a rectangular area (page) of the refresh memory.
WRITE TEXT	WT	Translates USASCII character codes to font data which is written into a rectangular area (page) of refresh memory.
WRITE RASTER	WR	Writes bit-per-element raster data into a rectangular area (page) of the refresh memory.
WRITE VECTOR	WV	Draws or erases a series of end-point vectors.
WRITE CONIC	WC	Draws (or erases) a prescribed conic.
WRITE PLOT	WP	Draws (or erases) a line plot, filled plot, or bar chart.
SCROLL X	SCPX	Performs a partitioned and windowed horizontal scroll.
SCROLL Y	SCPY	Performs a partitioned and windowed vertical scroll.
SAVE ENVIRONMENT	PUSH	Stores the current display system environment (including all 60 complex format instruction arguments) onto an internal processor stack.
RESTORE ENVIRONMENT ...	POP	Retrieves the last stored display system environment from the internal processor stack.
WRITE PROGRAMMABLE FONT	WPF	Writes bit-per-element font data into the character generators font buffer.
WRITE CURSOR STATE	WCS	Positions one of four cursors and establishes its state.
READ CURSOR STATUS	RCS	Retrieves the position and status of a particular cursor.
WRITE KEYBOARD	WKB	Writes a single character to a particular keyboard.
READ KEYBOARD	RKB	Reads the oldest buffered keystroke.
SENSE PERIPHERAL STATUS	SPS	Reads an internally maintained status word which identifies the locally interfaced peripheral devices which are contending for the host processors attention.

The machine instruction category provides for execution of machine-oriented functions such as directly loading or reading specific machine registers. These instructions are intended for diagnostic purposes and sophisticated users who demand speed or flexibility beyond that which is offered by the user-oriented instructions. Their use requires an intimate familiarity of the display generator, its architecture, registers, their format, and the specific hardware functions associated with each.

The user instruction category provides for execution of user-oriented functions such as write image, text, vector and plot. It is anticipated that most users will employ only this second, higher level instruction set. The design goals were simplicity, speed, power and flexibility. As a result, only a cursory knowledge of the Display System is required. Because the hardware design was dictated by, and optimized to process, the instruction set, the total system is inherently fast regardless of the fact that a microprocessor is used to interpret each instruction. This is accomplished by placing the microprocessor in an off-line state whenever possible, and allowing direct communication between the computer interface and display generator. The instruction set's power and flexibility can be realized by reviewing each instruction.

INSTRUCTION FORMATS

Figure 2-1 illustrates the standard instruction formats. The SHORT format instructions are a single 16 bit word in length and carry 8 bits of operand to the Display System. The IMMEDIATE format instructions are two 16 bit words in length and carry 8 bits of operand and 16 bits of data to the Display System. The COMPLEX format instructions are a variable number of 16 bit words in length and may carry both arguments and data to the Display System. These instructions are typically very powerful and are those most often used by the programmer. Those functions which are not suited to the above instruction formats are implemented as EXCEPTION format instructions. Each is implemented in a format best suited to the function being commanded.

ARGUMENTS

Table 2-4 lists the 16 possible arguments to the complex format instructions. Except for NOP, any of these instructions may set any combination of the possible arguments. The arguments are issued in ascending sequence. The OPERAND FLAG WORD specifies the presence of each argument. Interpretation is from right to left, that is, bit 2^0 flags argument 01 (SUBCHANNELS), bit 2^1 flags argument 02 (FOREGROUND), ..., and bit 2^{15} flags argument 16 (STARTPOINT). Each argument is one or more 16 bit words in length and describes a parameter which typically affects the operation of the instruction being decoded.

SHORT FORMAT



IMMEDIATE FORMAT

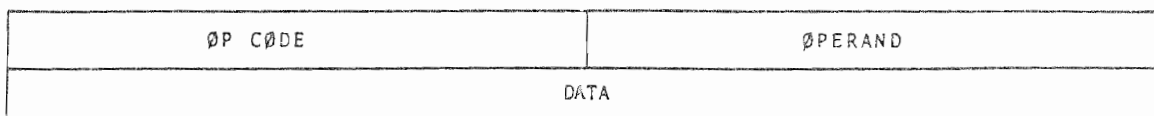

COMPLEX FORMAT

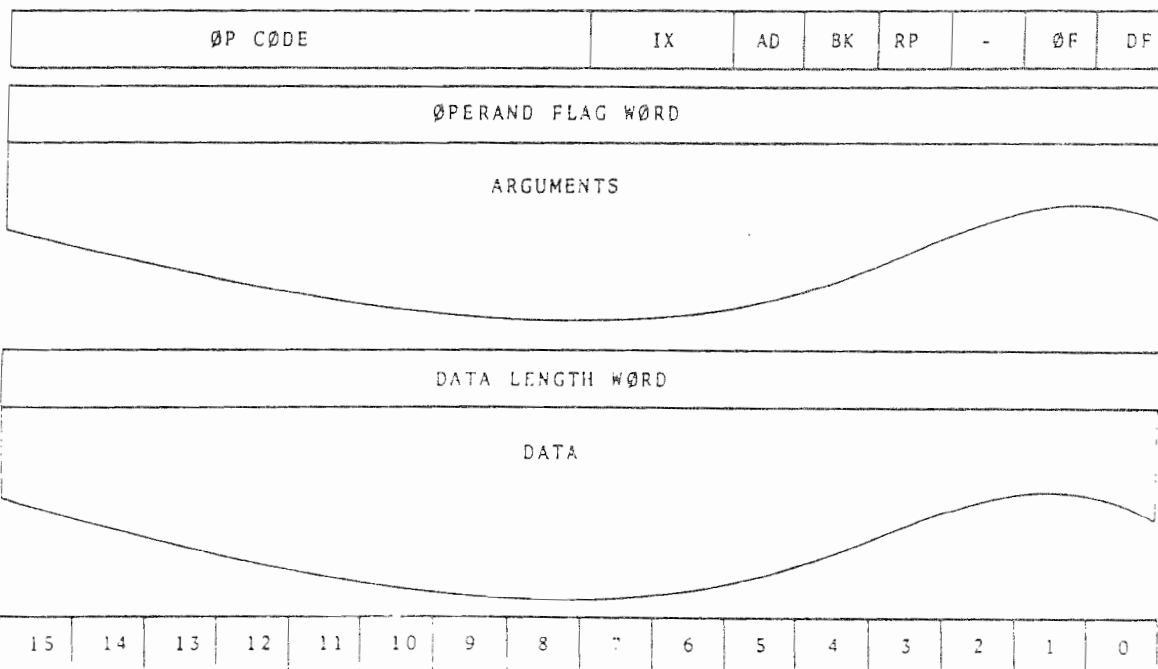

IX = Index (0 = absolute, 1 = index 1, 2 = index 2, 3 = relative)
 AD = Additive Write (0 = replacement, 1 = additive)
 BK = Reverse Background (0 = normal background, 1 = reversed background)
 RP = Reverse Packing (0 = left byte first, 1 = right byte first)
 ØF = Operand Flag (0 = no arguments exist, 1 = flagged arguments exist)
 DF = Data Flag (0 = no data exists, 1 = n data bytes exist)

FIGURE 2-1. RM-9100, 9200, and 9300 Instruction Formats

TABLE 2-4. Complex Format Instruction Arguments

No.	Name	Word Length	Description
01	SUBCHANNELS	01	Selects refresh memory bit planes to be affected.
02	BACKGROUND	01	Defines color or intensity for "one" state, two-dimensional data.
03	BACKGROUND	01	Defines color or intensity for "zero" state, two-dimensional data.
04	INDEX-1	02	Defines local refresh memory addressing origin.
05	INDEX-2	02	Defines local refresh memory addressing origin.
06	ORIGIN	02	Implements hardware scroll by assigning a particular refresh memory address as the origin of the TV raster.
07	WINDOW	04	Defines a rectangular area (or logical page) of refresh memory.
08	SCAN	01	Selects one of eight refresh memory scan sequences. Also selects character orientation and plot direction.
09	DIMENSION	02	Selects character matrix size and plot/bar segment width.
10	SPACING	02	Selects character and plot/bar segment spacing.
11	SCALE	01	Defines up/down scaling ratio up to 4:1 or 1:4.
12	FUNCTION	01	Selects one of eight logical or arithmetic imaging functions (OR, XOR, AND, SUM, DIFFERENCE, GREATEST VALUE, LEAST VALUE, or AVERAGE VALUE).
13	CONIC-EQUATION	12	Defines conical form for conics generator in terms of the equation $Ax^2 + By^2 + Cxy + Dx + Ey + F = 0$
14	BASE-LINE	01	Selects between line and filled plots. Also defines fixed-point base line for filled plots and bar charts.
15	SCROLL-COUNT	01	Defines scroll count (lines/elements) and directions.
16	START-POINT	02	Defines vector, conic, plot, bar chart, or irregular image, text, or raster data starting address.

DATA

Certain of the complex format instructions may carry data to the Display System, or retrieve data from the Display System. In either case, the DATA LENGTH WORD specifies the number of bytes to be transferred. Data format and interpretation varies from instruction to instruction. For example, for image data, each 16 bit word (2 bytes) is interpreted as a single pixel description. For raster data, each 8 bit byte is interpreted as a single-bit-per-element description of eight consecutive pixels. For text data, each byte is interpreted as a USASCII character code. For plot data, each 16 bit word (2 bytes) is interpreted as a plot point. Finally, for other graphics data, each 16 bit word pair (4 bytes) is interpreted as an end-point coordinate.

2-3 PHYSICAL SPECIFICATIONS

The following data specifies the physical characteristics of the Model RM-9100, 9200 and 9300 Graphic Display Systems:

DIMENSIONS

All systems are rail mountable in a standard 19 inch wide rack. The Model RM-9100 and 9200 require 8 3/4 inches of rack height. The Model RM-9300 requires 17 1/2 inches of rack height.

PRINTED CIRCUIT UTILIZATION

Except for certain low production computer interfaces and special video generators, the system (including backplane) is implemented in printed circuit.

CHASSIS LAYOUTS

Figures 2-2 and 2-3 illustrate the chassis layout for the Model RM-9100, 9200 and 9300 Graphic Display Systems. Each chassis provides receptacles for a computer interface board, controller board, memory option board, two serial link/cursor boards, a minimum of two video boards and two to eight memory boards (12 refresh planes). The Model 9300 chassis functionally differs from the Model 9100 and 9200 chassis in that up to four video boards can be accommodated.

2-4 ENVIRONMENTAL SPECIFICATIONS

The following data specifies the environmental characteristics of the Model RM-9100, 9200 and 9300 Graphic Display Systems:

TEMPERATURE

Operating temperature range is 0-50° C.

HUMIDITY

Humidity range is 0-95 percent, noncondensing.

2-5 POWER REQUIREMENTS

The power requirements are as follows:

LINE VOLTAGE

Line voltage requirements are 117 or 230 volts ± 10 percent.

LINE FREQUENCY

Line frequency requirements are 50/60 Hz ± 5 percent.

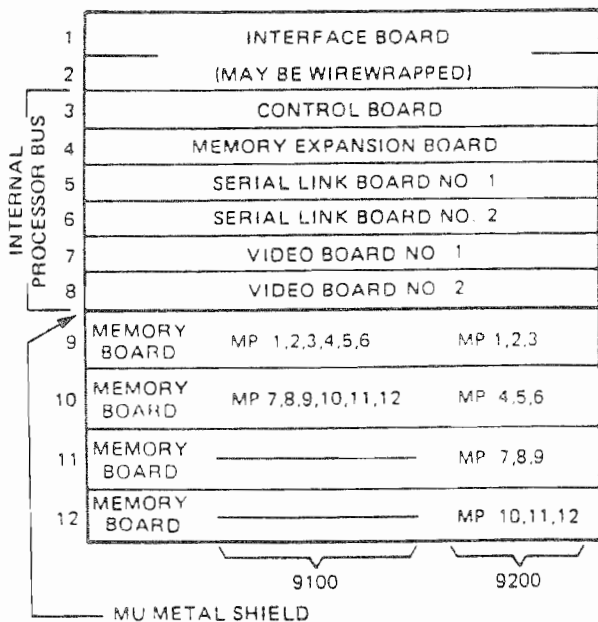
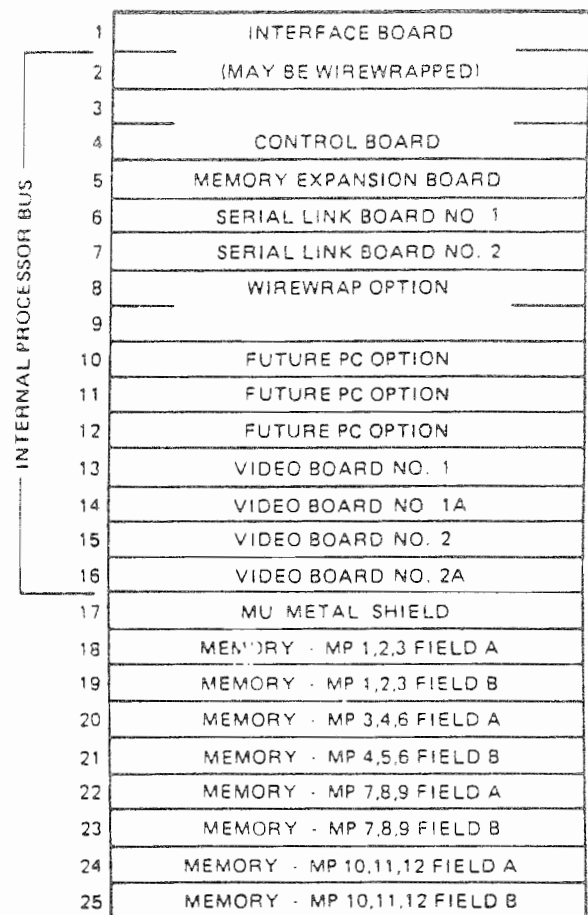

FIGURE 2-2. RM-9100 and 9200 Chassis Board Assignments



Notes: Slots 2 and 3 are also connected to the internal processor bus.
Field Clock = 0 for Field A.
Field Clock = 1 for Field B.

FIGURE 2-3. RM-9300 Chassis Board Assignment

SECTION III PERIPHERAL OPTIONS

3-1 INTRODUCTION

This section describes the peripheral options currently provided by Ramtek for the Models RM-9100, 9200 and 9300.

3-2 CURSOR DESCRIPTION

The Display Controller is capable of generating up to four cursors. The cursor appears as a cross (+) on the screen with the center element missing in the configurations and sizes shown in Figure 3-1. For the same size monitor, the cursor retains the same physical size regardless of the number of lines/elements or resolution of the system. Referring to Figure 3-1, the cursor shown in block "A" is representative of systems with 240 or 256 lines and 320 elements. The "B" block cursor is configured in systems of 240 or 256 lines and 640 elements. The "C" block illustrates cursor for 480 or 512 lines and 640 elements.

The cursor may be placed anywhere on the screen, including non-visible elements and lines in horizontal and vertical blanking. In other words, the cursor will not come to a stop at the edges of the visible portion of the screen, but will go beyond the edges and disappear into blanking. During CPU control of the cursor this is relatively unimportant as the CPU normally is programmed not to load data into non-visible elements. But under joystick or trackball control, the operator may guide the cursor into blanking. If the same direction is maintained, "rollover" will eventually occur and the cursor will reappear on the screen on the side opposite to that from which it disappeared, still maintaining the same direction.

3-3 JOYSTICK CURSOR CONTROLLER - GC-106

The joystick cursor controller is an interactive peripheral device used to position a cursor upon a video graphic display. The cursor controller consists of a joystick, four status switches (ENTER, TRACK, VISIBLE and BLINK), four channel select switches and a power switch. The controller interactively positions the cursor via the joystick, controls cursor status with the VISIBLE and BLINK status switches and informs the CPU of current coordinates and status by the ENTER and TRACK switches.

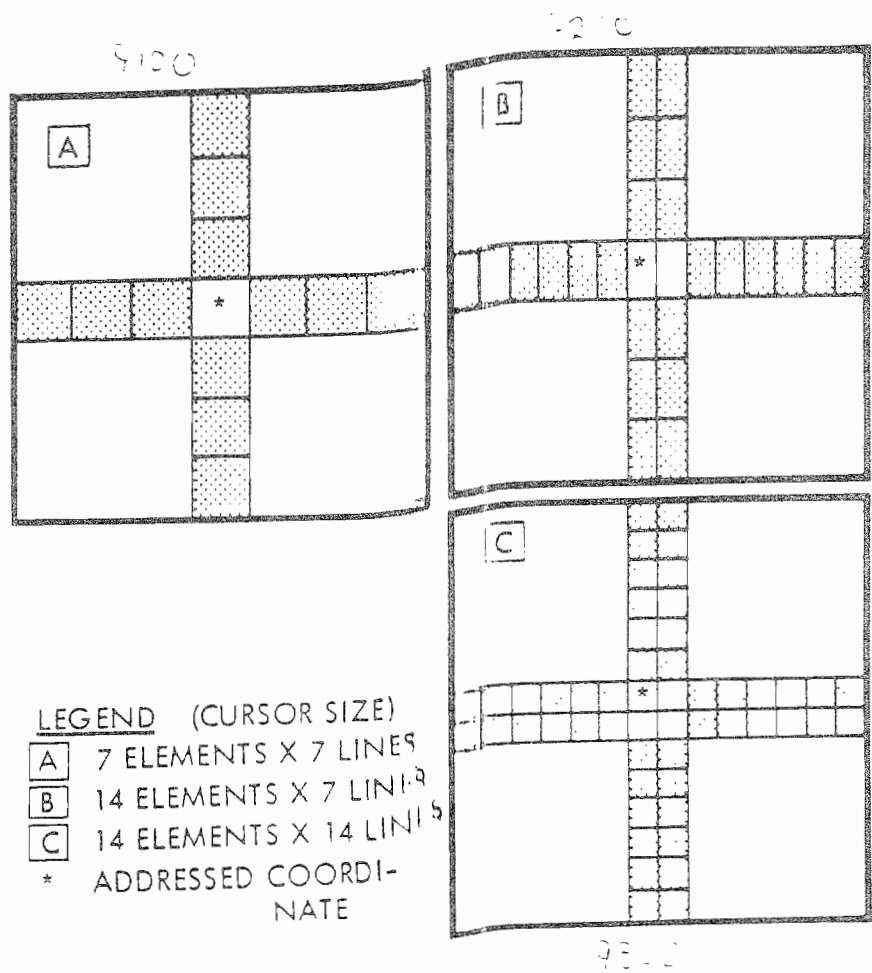

FIGURE 3-1. Cursor Configuration

The cursor controller interface with the serial link option. The cursor controller and trackball operate with the serial link option in an identical manner. Both use serial transmission lines to send data. The serial link option stores cursor coordinates and status while generating the cursor video image. The cursor controller does not store cursor coordinates, but issues increment/decrement commands to the serial link board which in turn update the cursor position on the screen. Since the amount of displacement of the joystick from the center position proportionately changes the rate of increment/decrement commands issued by the cursor controller, the further the joystick is displaced the faster the cursor moves on the screen. With a little practice, positioning of the cursor with the controller is simple, fast and more efficient than a trackball.

3-4 JOYSTICK OPERATION

The cursor controller is a directional rate device and not a positional control device. That is, when the joystick is moved in any direction from the center (at rest) position, the cursor begins to move slowly in the direction the joystick was displaced. The further the joystick is displaced from center, the faster the cursor moves in that direction. When the joystick is held in a constant position, the cursor moves across the screen at a constant rate. Release of the joystick returns it to the spring loaded position and stops cursor movement.

The joystick may be displaced at any single angle even though it feels easier to move the stick directly up, down, right or left. When viewed from the front, the position of the joystick corresponds exactly with the direction of the cursor movements as shown in Table 3-1.

TABLE 3-1. Joystick/Cursor Movement

Joystick Movement	Cursor Movement
Forward	Up
Backward	Down
Left	Left
Right	Right

The rate of cursor movement in any axis is infinitely variable from about 1 element/second when the stick is displaced $\approx 5^\circ$ deflection, to a maximum of traversing the screen from one edge to the other in about 3 seconds (full deflection). This mode of operation is used to move the cursor quickly from point to point.

A second mode of joystick operation allows one element cursor movement in any direction to easily and accurately position the cursor on a single screen element. To move the cursor one element only, the joystick is slightly displaced or "bumped". This action causes the cursor to move one element or line in the direction of joystick displacement. The cursor will not move any more elements until the stick is released and "bumped" again, or displaced further to start cursor movement as defined in the above mode.

This unique feature of the cursor controller allows the operator to be assured of moving the cursor one and only one element in any direction for ease in accurate positioning. The joystick displacement versus rate of cursor movement curve is not linear but exponential.

There is a small null zone around the center position of the joystick so that minimal displacements do not cause cursor movement. This prevents the cursor from "creeping" on the screen when the joystick is centered. The null zone also allows the cursor controller to be used without requiring trim adjustments of compensation for drift effects.

3-5 STATUS SWITCH OPERATION

Four status switches determine the status of the cursor on the screen and inform the CPU of current cursor coordinates. These switches are described as follows:

- a. VISIBLE. This alternate action switch turns the cursor ON or OFF. Cursor coordinates are not affected by the position of this switch.
- b. BLINK. The BLINK switch is an alternate action switch that, when ON, causes the cursor to blink at approximately a 1 Hz rate. When BLINK is OFF, the cursor remains steady on the screen. Cursor coordinates remain unaffected by the position of the BLINK switch.
- c. ENTER. ENTER is a momentary switch which causes current cursor coordinates and status to be sent to the CPU regardless of the position of any status switch or the position of the joystick. If the ENTER switch is held ON, the cursor controller ceases to function until the switch is released. As soon as the ENTER switch is released, the cursor controller resumes normal operation.
- d. TRACK. When ON, this alternate action switch causes every new coordinate to be entered into the CPU. Every movement of the cursor is defined to be a change in

coordinates. When the TRACK switch is OFF, the cursor still moves on the screen, but the coordinates are not issued to the CPU.

3-6 CHANNEL SELECT SWITCHES

Using the four channel select switches, the operator can control up to four cursors simultaneously with one cursor controller unit. These alternate action switches cause the output of the controller to be distributed to the output channel(s) selected by the switches. When a switch for any channel is ON, the output of the controller appears on the serial output for that channel. When the switch is OFF, the serial output for that channel goes to an idle or no transmission mode. Any combination of switches can be ON simultaneously including all ON or all OFF.

NOTE

CHANNEL SELECT SWITCHES SHOULD NEVER BE CHANGED WHILE MOVING THE CURSOR WITH THE JOYSTICK OR WHILE SWITCHING THE STATUS SWITCHES. SINCE THE CONTROLLER OPERATES WITH A SERIAL OUTPUT LINE, CHANGING THE CHANNEL SELECT SWITCHES WHILE THE UNIT IS TRANSMITTING MAY CAUSE UNPREDICTABLE RESULTS OF CURSOR MOVEMENT OR STATUS.

As long as the joystick is centered and the status switches are stationary, the channel select switches can be changed with no effects. Power does not need to be OFF to change the channel select switches.

3-7 TRACKBALL - GC-104

The Model GC-104-X Trackball is a self contained unit providing a serial output of a selectable baud rate. A character is sent whenever any of the control switches change and when the trackball is moved. The four changes of state which are switch controlled are BLINK, VISIBLE, ENTER and TRACK. These have been described previously in the joystick description. The baud rate is specified by the last digit of the model number as shown in Table 3-2.

TABLE 3-2. Trackball Baud Rate

Model	Baud Rate
GC-104-1	1200
GC-104-2	2400
GC-104-4	4800
GC-104-9	9600

At maximum (9600) baud rate the trackball sends up to 680 characters per second, enabling rapid movement of the cursor. A change in control state inhibits data. A data character (motion of the trackball) always includes the control bits, but only one direction per character either up, down, left or right.

3-8 PROCESS CONTROL KEYBOARD - GK-120

The GK-120 Process Control Keyboard contains the following items as standard:

- a. A 61 key typewriter keyboard that generates all 128 USASCII codes, including all alphanumeric, graphic and control characters. The keyboard features two key rollover/n key lockout operation. An auto-repeat feature of all keys is standard. Key arrangement is similar to the Model 37 teletype.
- b. Serial input and output options using a choice of EIA Standard RS-232C, TTY current loop, or short-line differential. Baud rates from 50 to 9600 baud; odd, even or no parity and one or two stop bits are selectable by the user.
- c. TTY mode operation allowing the keyboard to appear as a Model 33 teletype, generating a standard 93 character subset of USASCII. (Upper case alpha characters only).
- d. ON/OFF LINE switch allowing flexibility in the mode of operation of the keyboard.
- e. A 12 key cursor/function pad containing cursor up, down, right, left and home commands for computer controlled cursor. The remaining seven keys provide easily accessible function keys defined by the user.
- f. A convenient 12 key numeric pad containing 10 digits and 2 delimiter keys (. and ,).

This pad can be modified to provide 12 additional function keys defined by the user.

Optional features include 16 special function keys defined by the user with corresponding CPU controlled status lights. Up to 40 function keys can be provided, each assigned with two codes per key. All function keys generate eight bit codes above ASCII (Octal 200-377). An attention signal activated by the reception of the USASCII defined "Bell" code.

All codes are 8 bit data. The code assignments are shown in Table 33.

The alphanumeric section contains all functions including alphanumeric, control and graphic characters as defined by USASCII. Octal codes 000 through 177 are generated here.

If the numeric pad is selected, the codes issued are strictly the numeric and delimiter codes of the alphanumeric section. That is, when the keyboard is in the unshifted, uncontrolled mode, pressing the numeral "4" will issue the ASCII code for "4". When in the shifted mode, pressing "4" will also issue the ASCII code for "4".

TABLE 3-3. GK-120 Code Assignments

	0	1	2	3	4	5	6	7
00	NUL	SOH	STX	ETX	EOT	ENQ	ACK	BEL
01	BS	HT	LF	VT	FF	CR	SO	SI
02	DLE	DC1	DC2	DC3	DC4	NAK	SYN	ETB
03	CAN	EM	SUB	ESC	FS	GS	RS	US
04	SP	!	"	#	\$	%	&	'
05	()	*	+	,	-	.	/
06	0	1	2	3	4	5	6	7
07	8	9	:	;	<	=	>	?
10	@	A	B	C	D	E	F	G
11	H	I	J	K	L	M	N	O
12	P	Q	R	S	T	U	V	W
13	X	Y	Z	[\]	^	_
14	`	a	b	c	d	e	f	g
15	h	i	j	k	l	m	n	o
16	p	q	r	s	t	u	v	w
17	x	y	z	{		}	~	DEL

ASCII (octal)

Alphanumeric Section
 Numeric Pad



	0	1	2	3	4	5	6	7
20	f ₁	f ₂	f ₃	f ₄	f ₅	f ₆	f ₇	f ₈
21	f ₉	f ₁₀	f ₁₁	f ₁₂	f ₁₃	f ₁₄	f ₁₅	f ₁₆
22	f ₁₇	f ₁₈	f ₁₉	f ₂₀	f ₂₁	f ₂₂	f ₂₃	HOME
23	f ₂₅	f ₂₆	f ₂₇	f ₂₈	f ₂₉	f ₃₀	f ₃₁	f ₃₂
24	f ₃₃	f ₃₄	f ₃₅	f ₃₆	f ₃₇	f ₃₈	f ₃₉	f ₄₀
25								
26								
27								
30	f ₁	f ₂	f ₃	f ₄	f ₅	f ₆	f ₇	f ₈
31	f ₉	f ₁₀	f ₁₁	f ₁₂	f ₁₃	f ₁₄	f ₁₅	f ₁₆
32	f ₁₇	f ₁₈	f ₁₉	f ₂₀	f ₂₁	f ₂₂	f ₂₃	HOME
33	f ₂₅	f ₂₆	f ₂₇	f ₂₈	f ₂₉	f ₃₀	f ₃₁	f ₃₂
34	f ₃₃	f ₃₄	f ₃₅	f ₃₆	f ₃₇	f ₃₈	f ₃₉	f ₄₀
35								
36								
37								

NON-ASCII (octal)

Cursor Pad
 Function Pad
 Special Functions
 Status Lights

If the function pad replaces the numeric pad, all functions are defined by the user. The codes issued are above ASCII, Octal 200 and higher.

The cursor pad contains the five cursor controls: cursor up, down, right, left and home. Each key has two codes associated with it providing the ability for slow and fast computer controlled cursor. The remaining 7 keys in the cursor pad are defined by the user. The codes issued are above ASCII, Octal 200 and higher.

If the 16 special function keys are included on the keyboard, all functions are defined by the user. Note that each key is assigned with two codes. The codes are above ASCII, Octal 200 and higher.

Due to MOS encoding techniques, note that all codes are preassigned by Ramtek and are unalterable. However, the user is free to assign function meaning and keytop legends to all keys.

The shift and control keys determine the coded output of all keys. For example, consider the key labeled "A" where "-" indicates key not pressed, "x" indicates key is pressed.

Shift	Control	Function	Octal Code Output
-	-	a	141
x	-	A	101
-	x	SOH	1
x	x	SOH	1

The control key allows only ASCII defined control characters (Octal 000-040 and 177) and all codes not defined by ASCII (Octal 200-377) to be serially outputted. All other codes are inhibited from appearing at the serial outputs when the control key is pressed. This is equivalent to a key being mechanically locked out on a teletype. The shift key does not lockout any codes. As an example of the control key locking out the above indicated codes consider the key labeled with the numeral "3".

Shift	Control	Function	Octal Code Output
-	-	3	63
x	-	3	43
-	x	3	Not Outputted (Lockout Operation)

Compare this with the Key "A" operation to see the difference.

Notice that both the shift and control keys determine the coded output of the keys in the alphanumeric section, but for all other sections (cursor pad, numeric/function pad and special functions), the shift key has no effect. Only the control key will determine the coded output for the keys in these sections. There are two shift keys on the keyboard with one alternate action shift lock. Only one control key is provided.

Placing the keyboard in TTY mode causes the logic to suppress lower case alpha characters. When in TTY mode, the keyboard generates a 93 character subset of ASCII. Only the keys in the alphanumeric section are affected. The codes for all other sections of the keyboard (cursor pad, numeric/function pad and special function) remain unaffected by TTY mode.

In TTY mode, the codes are altered using the following rules.

a. ASCII

1. Octal codes 000 to 137: retain as is.
2. Octal codes 140 to 176: subtract Octal 40 to convert these codes to upper case characters. That is, convert 140 through 176 to 100 through 136.
3. Octal code 177 (delete): retain as is.

b. NON-ASCII Octal codes 200 to 377: retain as is.

This information is tabulated in Table 3-4.

Table 3-4 GK-120 TTY Mode Control

	0	1	2	3	4	5	6	7
00	NUL	SOH	STX	ETX	EOT	ENQ	ACK	BEL
01	BS	HT	LF	VT	FF	CR	SO	SI
02	DLE	DC1	DC2	DC3	DC4	NAK	SYN	ETB
03	CAN	EM	SUB	ESC	FS	GS	RS	US
04	SP	!	"	#	\$	%	&	'
05	()	*	+	,	-	.	/
06	0	1	2	3	4	5	6	7
07	8	9	:	;	<	=	>	?
10	@	A	B	C	D	E	F	G
11	H	I	J	K	L	M	N	O
12	P	Q	R	S	T	U	V	W
13	X	Y	Z	[\]	^	_
14	~	a	b	c	d	e	f	g
15	h	i	j	k	l	m	n	o
16	p	q	r	s	t	u	v	w
17	x	y	z	{		}	~	DEL

ASCII (Octal)

	0	1	2	3	4	5	6	7
20	f ₁	f ₂	f ₃	f ₄	f ₅	f ₆	f ₇	f ₈
21	f ₉	f ₁₀	f ₁₁	f ₁₂	f ₁₃	f ₁₄	f ₁₅	f ₁₆
22	f ₁₇	f ₁₈	f ₁₉	f ₂₀	f ₂₁	f ₂₂	f ₂₃	f ₂₄
23	f ₂₅	f ₂₆	f ₂₇	f ₂₈	f ₂₉	f ₃₀	f ₃₁	f ₃₂
24	f ₃₃	f ₃₄	f ₃₅	f ₃₆	f ₃₇	f ₃₈	f ₃₉	f ₄₀
25								
26								
27								
30	f ₁	f ₂	f ₃	f ₄	f ₅	f ₆	f ₇	f ₈
31	f ₉	f ₁₀	f ₁₁	f ₁₂	f ₁₃	f ₁₄	f ₁₅	f ₁₆
32	f ₁₇	f ₁₈	f ₁₉	f ₂₀	f ₂₁	f ₂₂	f ₂₃	f ₂₄
33	f ₂₅	f ₂₆	f ₂₇	f ₂₈	f ₂₉	f ₃₀	f ₃₁	f ₃₂
34	f ₃₃	f ₃₄	f ₃₅	f ₃₆	f ₃₇	f ₃₈	f ₃₉	f ₄₀
35								
36								
37								

Uncontrol

Control

NON-ASCII (Octal)

For TTY operation, subtract octal 040 from these indicated codes to obtain upper case alpha characters. (Convert octal 140 through 176 to octal 100 through 136.) Example: "a" converts to "A", "(" converts to "C".

The following example shows how TTY mode affects keyboard behavior. In the unshift, uncontrol state, when the operator presses the key "A", normally the code for small letter "a" is issued (Octal 141). However, in TTY mode the capital letter "A" is issued instead (Octal 101). This is shown as follows:

Shift	Control	Function	Octal Code Output
-	-	A	101
x	-	A	101
-	x	SOH	1
-	x	SOH	1

The auto repeat feature provides that any key, if held down continuously for longer than one second, will automatically repeat until the key is released. If more than one key is held down, only the first key struck will repeat. The output will not alternate between two keys. The time delay until any key begins to repeat is normally one second. The repeat rate is 10 characters per second for all keyboards, regardless of baud rate. The cursor keys have been defined with two codes per key allowing the ability to distinguish between slow and fast cursor commands. Both the time delay and repeat rate are hard-wired and are not under CPU control.

Two key rollover/n-key lockout is provided such that after a key closure is recognized by the keyboard logic and the appropriate code for that key is issued, all further key depressions are ignored. No further codes will be issued until the first key is released.

With n-key lockout, the following characteristics are to be expected:

- a. Lockout. If a key is depressed and not released, the code for that key is issued and the keyboard scan stops, locking out any recognition of further key depressions. Any other keys depressed and released will not be recognized. As soon as the original key is released, keyboard scan resumes until another key depression is found.
- b. 2-key rollover. 2-key rollover can be experienced with n-key lockout. Depress the first key and its code is issued, stopping keyboard scan. Press the second key and no code is issued. But now, still holding the second key down, release the first key (starting keyboard scan) and the second key will now be recognized and its code will be issued. Keyboard scan now stops again until the second key is released. This chain action can be continued indefinitely.

- c. Multiple depressions. If a key is depressed and held, its code will be issued. While continuing to hold the first key, if additional keys are depressed and held no further codes will be issued until the first key is released and the next code issued will be unpredictable. It depends upon which key is encountered first by the scanning mechanism and only that one code will be issued.
- d. Simultaneous depression. The first code issued is unpredictable. It depends upon the current position of the keyboard scan mechanism. Only one code will be issued.

The CPU can sound an attention signal by using the ASCII defined code for "bell" (BEL = Octal code 007). The signal will remain active for approximately one second after the keyboard reception of the "bell" code. If a continuous signal is required, the CPU can retrigger the attention device as many times as required. The signal can be retriggered at any point in its cycle, but the signal will only remain active for one second after the last "bell" code received. The attention signal is Mallory's SONALERT^C with a fixed frequency of 2,900 Hz.

Status lights, under CPU control, are provided by the LED's directly above the special function keys. The lights may be turned on or off by the CPU using the instruction format shown below. The operator has no control over the operation of the status lights.

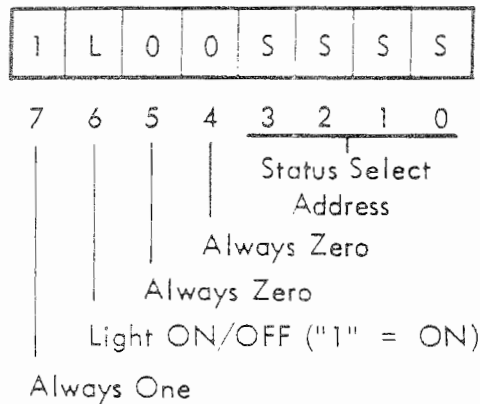

Facing the keyboard from the front, the status lights are addressed from 0 to 15 from left to right. Since the operation of the status lights is independent of the special function keys, the user may associate key functions with status lights or completely divorce the two.