

# MC68HC708MP16

## Data Sheet

**M68HC08**  
**Microcontrollers**

**Rev. 3.1**  
**MC68HC708MP16/D**  
**July 28, 2005**

*freescale.com*





## List of Sections

Section 1. General Description . . . . .	29
Section 2. Memory Map . . . . .	39
Section 3. Random-Access Memory (RAM) . . . . .	53
Section 4. EPROM/OTPROM . . . . .	55
Section 5. Configuration Register (CONFIG) . . . . .	59
Section 6. Central Processor Unit (CPU) . . . . .	63
Section 7. System Integration Module (SIM) . . . . .	81
Section 8. Clock Generator Module (CGM) . . . . .	103
Section 9. Pulse Width Modulator for Motor Control (PWMMC) . . . . .	129
Section 10. Monitor ROM (MON) . . . . .	191
Section 11. Timer Interface Module A (TIMA) . . . . .	201
Section 12. Timer Interface Module B (TIMB) . . . . .	225
Section 13. Serial Peripheral Interface Module (SPI) . . . . .	251
Section 14. Serial Communications Interface Module (SCI) . . . . .	283
Section 15. Input/Output (I/O) Ports . . . . .	317
Section 16. Computer Operating Properly (COP) . . . . .	333
Section 17. External Interrupt (IRQ) . . . . .	339

Section 18. Low-Voltage Inhibit (LVI) . . . . .	347
Section 19. Analog-to-Digital Converter (ADC) . . . . .	353
Section 20. Power-On Reset (POR) . . . . .	365
Section 21. Electrical Specifications . . . . .	367
Section 22. Mechanical Specifications . . . . .	379
Section 23. Ordering Information . . . . .	381
Glossary . . . . .	383

## Table of Contents

### Section 1. General Description

1.1	Contents . . . . .	29
1.2	Introduction . . . . .	30
1.3	Features . . . . .	30
1.4	MCU Block Diagram . . . . .	31
1.5	Pin Assignments . . . . .	33
1.5.1	Power Supply Pins ( $V_{DD}$ and $V_{SS}$ ) . . . . .	35
1.5.2	Oscillator Pins (OSC1 and OSC2) . . . . .	35
1.5.3	External Reset Pin ( $\overline{RST}$ ) . . . . .	35
1.5.4	External Interrupt Pin ( $\overline{IRQ1}/V_{PP}$ ) . . . . .	36
1.5.5	CGM Power Supply Pins ( $V_{DDA}$ and $V_{SSA}$ ) . . . . .	36
1.5.6	External Filter Capacitor Pin (CGMXFC) . . . . .	36
1.5.7	Analog Power Supply Pins ( $V_{DDAD}/V_{DDAREF}$ and $V_{SSAD}$ ) . . . . .	36
1.5.8	ADC Voltage Decoupling Capacitor Pin ( $V_{ADCAP}$ ) . . . . .	36
1.5.9	ADC Voltage Reference Low Pin ( $V_{REFL}$ ) . . . . .	37
1.5.10	Port A Input/Output (I/O) Pins (PTA7–PTA0) . . . . .	37
1.5.11	Port B I/O Pins (PTB7/ATD7–PTB0/ATD0) . . . . .	37
1.5.12	Port C I/O Pins (PTC6–PTC2 and PTC1/ATD9–PTC0/ATD8) . . . . .	37
1.5.13	Port D Input-Only Pins (PTD6/ $\overline{IS3}$ –PTD4/ $\overline{IS1}$ and PTD3/FAULT4–PTD0/FAULT1) . . . . .	37
1.5.14	PWM Pins (PWM6–PWM1) . . . . .	38
1.5.15	PWM Ground Pin (PWMGND) . . . . .	38
1.5.16	Port E I/O Pins (PTE7/TCH3B–PTE3/TCLKB and PTE2/TCH1A–PTE0/TCLKA) . . . . .	38
1.5.17	Port F I/O Pins (PTF5/TxD–PTF4/RxD and PTF3/MISO–PTF0/SPSCK) . . . . .	38

## Section 2. Memory Map

2.1	Contents . . . . .	39
2.2	Introduction . . . . .	39
2.3	Input/Output (I/O) Section . . . . .	41
2.4	Monitor ROM . . . . .	52

## Section 3. Random-Access Memory (RAM)

3.1	Contents . . . . .	53
3.2	Introduction . . . . .	53
3.3	Functional Description . . . . .	53

## Section 4. EPROM/OTPROM

4.1	Contents . . . . .	55
4.2	Introduction . . . . .	55
4.3	Functional Description . . . . .	55
4.4	EPROM/OTPROM Control Register . . . . .	56
4.5	EPROM/OTPROM Programming Sequence . . . . .	57

## Section 5. Configuration Register (CONFIG)

5.1	Contents . . . . .	59
5.2	Introduction . . . . .	59
5.3	Functional Description . . . . .	60

## Section 6. Central Processor Unit (CPU)

6.1	Contents . . . . .	63
6.2	Introduction . . . . .	63
6.3	Features . . . . .	64

6.4	CPU Registers	64
6.4.1	Accumulator (A)	65
6.4.2	Index Register (H:X)	66
6.4.3	Stack Pointer (SP)	67
6.4.4	Program Counter (PC)	68
6.4.5	Condition Code Register (CCR)	69
6.5	Arithmetic/Logic Unit (ALU)	71
6.6	Instruction Set Summary	72
6.7	Opcode Map	79

## Section 7. System Integration Module (SIM)

7.1	Contents	81
7.2	Introduction	82
7.3	SIM Bus Clock Control and Generation	85
7.3.1	Bus Timing	85
7.3.2	Clock Start-Up from POR or LVI Reset	85
7.3.3	Clocks in Wait Mode	86
7.4	Reset and System Initialization	86
7.4.1	External Pin Reset	87
7.4.2	Active Resets from Internal Sources	88
7.4.2.1	Power-On Reset	89
7.4.2.2	Computer Operating Properly (COP) Reset	90
7.4.2.3	Illegal Opcode Reset	90
7.4.2.4	Illegal Address Reset	90
7.4.2.5	Low-Voltage Inhibit (LVI) Reset	91
7.5	SIM Counter	91
7.5.1	SIM Counter During Power-On Reset	91
7.5.2	SIM Counter and Reset States	91
7.6	Exception Control	92
7.6.1	Interrupts	92
7.6.1.1	Hardware Interrupts	94
7.6.1.2	SWI Instruction	95
7.6.2	Reset	96
7.6.3	Status Flag Protection in Break Mode	96

7.7	Low-Power Mode	96
7.7.1	Wait Mode	97
7.7.2	SIM Break Status Register	99
7.7.3	SIM Reset Status Register	101
7.7.4	SIM Break Flag Control Register	102

## Section 8. Clock Generator Module (CGM)

8.1	Contents	103
8.2	Introduction	104
8.3	Features	104
8.4	Functional Description	105
8.4.1	Crystal Oscillator Circuit	105
8.4.2	Phase-Locked Loop Circuit (PLL)	107
8.4.2.1	PLL Circuits	107
8.4.2.2	Acquisition and Tracking Modes	109
8.4.2.3	Manual and Automatic PLL Bandwidth Modes	109
8.4.2.4	Programming the PLL	111
8.4.2.5	Special Programming Exceptions	112
8.4.3	Base Clock Selector Circuit	112
8.4.4	CGM External Connections	113
8.5	I/O Signals	114
8.5.1	Crystal Amplifier Input Pin (OSC1)	114
8.5.2	Crystal Amplifier Output Pin (OSC2)	114
8.5.3	External Filter Capacitor Pin (CGMXFC)	114
8.5.4	PLL Analog Power Pin ( $V_{DDA}$ )	115
8.5.5	Oscillator Enable Signal (SIMOSCEN)	115
8.5.6	Crystal Output Frequency Signal (CGMXCLK)	115
8.5.7	CGM Base Clock Output (CGMOUT)	115
8.5.8	CGM CPU Interrupt (CGMINT)	116
8.6	CGM Registers	116
8.6.1	PLL Control Register	117
8.6.2	PLL Bandwidth Control Register	119
8.6.3	PLL Programming Register	121
8.7	Interrupts	123
8.8	Wait Mode	123



8.9	CGM During Break Mode . . . . .	124
8.10	Acquisition/Lock Time Specifications . . . . .	124
8.10.1	Acquisition/Lock Time Definitions . . . . .	124
8.10.2	Parametric Influences on Reaction Time . . . . .	126
8.10.3	Choosing a Filter Capacitor . . . . .	127
8.10.4	Reaction Time Calculation . . . . .	127

## **Section 9. Pulse Width Modulator for Motor Control (PWMMC)**

9.1	Contents . . . . .	129
9.2	Introduction . . . . .	130
9.3	Features . . . . .	131
9.4	Timebase . . . . .	135
9.4.1	Resolution . . . . .	135
9.4.2	Prescaler . . . . .	137
9.5	PWM Generators . . . . .	137
9.5.1	Load Operation . . . . .	137
9.5.2	PWM Data Overflow and Underflow Conditions . . . . .	142
9.6	Output Control . . . . .	142
9.6.1	Selecting Six Independent PWMs or Three Complementary PWM Pairs . . . . .	142
9.6.2	Dead-Time Insertion . . . . .	144
9.6.3	Top/Bottom Correction . . . . .	149
9.6.3.1	Manual Correction . . . . .	152
9.6.3.2	Automatic Correction . . . . .	154
9.6.4	Output Polarity . . . . .	156
9.6.5	Output Port Control . . . . .	158
9.7	Fault Protection . . . . .	159
9.7.1	Fault Condition Input Pins . . . . .	164
9.7.1.1	Fault Pin Filter . . . . .	165
9.7.1.2	Automatic Mode . . . . .	165
9.7.1.3	Manual Mode . . . . .	166
9.7.2	Software Output Disable . . . . .	168
9.7.3	Output Port Control . . . . .	168

9.8	Initialization and the PWMEN Bit	169
9.9	PWM Operation in Wait Mode	171
9.10	PWM Operation in Break Mode	171
9.11	Control Logic Block	172
9.11.1	PWM Counter Registers	172
9.11.2	PWM Counter Modulo Registers	173
9.11.3	PWM X Value Registers	174
9.11.4	PWM Control Register 1	175
9.11.5	PWM Control Register 2	177
9.11.6	Dead-Time Write-Once Register	179
9.11.7	PWM Disable Mapping Write-Once Register	180
9.11.8	Fault Control Register	180
9.11.9	Fault Status Register	183
9.11.10	Fault Acknowledge Register	185
9.11.11	PWM Output Control Register	186
9.12	PWM Glossary	188

## Section 10. Monitor ROM (MON)

10.1	Contents	191
10.2	Introduction	191
10.3	Features	192
10.4	Functional Description	192
10.4.1	Entering Monitor Mode	194
10.4.2	Data Format	195
10.4.3	Echoing	196
10.4.4	Break Signal	196
10.4.5	Commands	197
10.4.6	Baud Rate	200

## Section 11. Timer Interface Module A (TIMA)

11.1	Contents	201
11.2	Introduction	202
11.3	Features	202
11.4	Functional Description	202
11.4.1	TIMA Counter Prescaler	205
11.4.2	Input Capture	205
11.4.3	Output Compare	205
11.4.3.1	Unbuffered Output Compare	206
11.4.3.2	Buffered Output Compare	207
11.4.4	Pulse Width Modulation (PWM)	207
11.4.4.1	Unbuffered PWM Signal Generation	209
11.4.4.2	Buffered PWM Signal Generation	210
11.4.4.3	PWM Initialization	210
11.5	Interrupts	212
11.6	Wait Mode	212
11.7	TIMA During Break Interrupts	213
11.8	I/O Signals	213
11.8.1	TIMA Clock Pin (PTE0/TCLKA)	213
11.8.2	TIMA Channel I/O Pins (PTE1/TCH0A:PTE2/TCH1A)	214
11.9	I/O Registers	214
11.9.1	TIMA Status and Control Register	215
11.9.2	TIMA Counter Registers	217
11.9.3	TIMA Counter Modulo Registers	218
11.9.4	TIMA Channel Status and Control Registers	219
11.9.5	TIMA Channel Registers	223

## Section 12. Timer Interface Module B (TIMB)

12.1	Contents	225
12.2	Introduction	226
12.3	Features	226

## Table of Contents

12.4	Functional Description	226
12.4.1	TIMB Counter Prescaler	230
12.4.2	Input Capture	230
12.4.3	Output Compare	230
12.4.3.1	Unbuffered Output Compare	230
12.4.3.2	Buffered Output Compare	231
12.4.4	Pulse Width Modulation (PWM)	232
12.4.4.1	Unbuffered PWM Signal Generation	233
12.4.4.2	Buffered PWM Signal Generation	234
12.4.4.3	PWM Initialization	235
12.5	Interrupts	237
12.6	Wait Mode	237
12.7	TIMB During Break Interrupts	238
12.8	I/O Signals	238
12.8.1	TIMB Clock Pin (PTE3/TCLKB)	238
12.8.2	TIMB Channel I/O Pins (PTE4/TCH0B:PTE7/TCH3B)	239
12.9	I/O Registers	239
12.9.1	TIMB Status and Control Register	240
12.9.2	TIMB Counter Registers	242
12.9.3	TIMB Counter Modulo Registers	243
12.9.4	TIMB Channel Status and Control Registers	244
12.9.5	TIMB Channel Registers	248

## Section 13. Serial Peripheral Interface Module (SPI)

13.1	Contents	251
13.2	Introduction	252
13.3	Features	252
13.4	Pin Name Conventions	253
13.5	Functional Description	254
13.5.1	Master Mode	255
13.5.2	Slave Mode	257

13.6	Transmission Formats	258
13.6.1	Clock Phase and Polarity Controls	258
13.6.2	Transmission Format When CPHA = 0	258
13.6.3	Transmission Format When CPHA = 1	260
13.6.4	Transmission Initiation Latency	261
13.7	Queuing Transmission Data	263
13.8	Error Conditions	264
13.8.1	Overflow Error	264
13.8.2	Mode Fault Error	267
13.9	Interrupts	269
13.10	Resetting the SPI	271
13.11	Low-Power Mode	272
13.12	SPI During Break Interrupts	272
13.13	I/O Signals	273
13.13.1	MISO (Master In/Slave Out)	273
13.13.2	MOSI (Master Out/Slave In)	274
13.13.3	SPSCK (Serial Clock)	274
13.13.4	$\overline{SS}$ (Slave Select)	274
13.13.5	CGND (Clock Ground)	276
13.14	I/O Registers	276
13.14.1	SPI Control Register	277
13.14.2	SPI Status and Control Register	279
13.14.3	SPI Data Register	282

## Section 14. Serial Communications Interface Module (SCI)

14.1	Contents	283
14.2	Introduction	284
14.3	Features	284

## Table of Contents

14.4	Functional Description	285
14.4.1	Data Format	288
14.4.2	Transmitter	288
14.4.2.1	Character Length	288
14.4.2.2	Character Transmission	289
14.4.2.3	Break Characters	291
14.4.2.4	Idle Characters	291
14.4.2.5	Inversion of Transmitted Output	292
14.4.2.6	Transmitter Interrupts	292
14.4.3	Receiver	293
14.4.3.1	Character Length	294
14.4.3.2	Character Reception	294
14.4.3.3	Data Sampling	294
14.4.3.4	Framing Errors	297
14.4.3.5	Receiver Wake-Up	297
14.4.3.6	Receiver Interrupts	298
14.4.3.7	Error Interrupts	298
14.5	Wait Mode	299
14.6	SCI During Break Module Interrupts	299
14.7	I/O Signals	300
14.7.1	PTF5/TxD (Transmit Data)	300
14.7.2	PTF4/RxD (Receive Data)	300
14.8	I/O Registers	300
14.8.1	SCI Control Register 1	301
14.8.2	SCI Control Register 2	304
14.8.3	SCI Control Register 3	307
14.8.4	SCI Status Register 1	309
14.8.5	SCI Status Register 2	313
14.8.6	SCI Data Register	314
14.8.7	SCI Baud Rate Register	314

## Section 15. Input/Output (I/O) Ports

15.1	Contents	317
15.2	Introduction	318

15.3	Port A	320
15.3.1	Port A Data Register	320
15.3.2	Data Direction Register A	320
15.4	Port B	322
15.4.1	Port B Data Register	322
15.4.2	Data Direction Register B	322
15.5	Port C	324
15.5.1	Port C Data Register	324
15.5.2	Data Direction Register C	325
15.6	Port D	326
15.7	Port E	328
15.7.1	Port E Data Register	328
15.7.2	Data Direction Register E	329
15.8	Port F	330
15.8.1	Port F Data Register	330
15.8.2	Data Direction Register F	331

## Section 16. Computer Operating Properly (COP)

16.1	Contents	333
16.2	Introduction	333
16.3	Functional Description	334
16.4	I/O Signals	335
16.4.1	CGMXCLK	335
16.4.2	COPCTL Write	335
16.4.3	Power-On Reset	335
16.4.4	Internal Reset	336
16.4.5	Reset Vector Fetch	336
16.4.6	COPD (COP Disable)	336
16.5	COP Control Register	336
16.6	Interrupts	337
16.7	Monitor Mode	337
16.8	Wait Mode	337
16.9	COP Module During Break Mode	337

## Section 17. External Interrupt (IRQ)

17.1	Contents	339
17.2	Introduction	339
17.3	Features	339
17.4	Functional Description	340
17.5	$\overline{\text{IRQ1}}/\text{V}_{\text{PP}}$ Pin	343
17.6	IRQ Module During Break Mode	344
17.7	IRQ Status and Control Register	345

## Section 18. Low-Voltage Inhibit (LVI)

18.1	Contents	347
18.2	Introduction	347
18.3	Features	347
18.4	Functional Description	348
18.4.1	Polled LVI Operation	349
18.4.2	Forced Reset Operation	349
18.4.3	False Reset Protection	349
18.5	LVI Status Register	350
18.6	LVI Interrupts	351
18.7	Wait Mode	351

## Section 19. Analog-to-Digital Converter (ADC)

19.1	Contents	353
19.2	Introduction	354
19.3	Features	354
19.4	Functional Description	354
19.4.1	ADC Port I/O Pins	356
19.4.2	Voltage Conversion	356
19.4.3	Conversion Time	356



19.4.4	Continous Conversion	357
19.4.5	Accuracy and Precision	357
19.5	Interrupts	357
19.6	Wait Mode	357
19.7	I/O Signals	358
19.7.1	ADC Analog Power Pin ( $V_{DDAD}$ )	358
19.7.2	ADC Analog Ground Pin ( $V_{SSAD}$ )	358
19.7.3	ADC Voltage Reference Pin ( $V_{DDAREF}$ )	358
19.7.4	ADC Voltage Decoupling Capacitor Pin ( $V_{ADCAP}$ )	358
19.7.5	ADC Voltage Reference Low Pin ( $V_{REFL}$ )	359
19.7.6	ADC Voltage In (ADVIN)	359
19.8	I/O Registers	359
19.8.1	ADC Status and Control Register	360
19.8.2	ADC Data Register	363
19.8.3	ADC Clock Register	363

## Section 20. Power-On Reset (POR)

20.1	Contents	365
20.2	Introduction	365
20.3	Functional Description	365

## Section 21. Electrical Specifications

21.1	Contents	367
21.2	Introduction	367
21.3	Absolute Maximum Ratings	368
21.4	Functional Operating Range	369
21.5	Thermal Characteristics	369
21.6	DC Electrical Characteristics	370
21.7	Control Timing	371
21.8	Serial Peripheral Interface Characteristics	372
21.9	Timer Interface Module Characteristics	375

21.10	Clock Generation Module Electrical Characteristics . . . . .	375
21.11	Analog-to-Digital Converter (ADC) Characteristics . . . . .	377
21.12	Memory Characteristics . . . . .	377

## Section 22. Mechanical Specifications

22.1	Contents . . . . .	379
22.2	Introduction . . . . .	379
22.3	Plastic Quad Flat Pack (QFP) . . . . .	380

## Section 23. Ordering Information

23.1	Contents . . . . .	381
23.2	Introduction . . . . .	381
23.3	MC Order Numbers . . . . .	381

## Glossary

## List of Figures

Figure	Title	Page
1-1	MCU Block Diagram . . . . .	32
1-2	SDIP Pin Assignments . . . . .	33
1-3	QFP Pin Assignments . . . . .	34
1-4	Power Supply Bypassing . . . . .	35
2-1	Memory Map . . . . .	40
2-2	Control, Status, and Data Registers . . . . .	42
4-1	EPROM/OTPROM Control Register (EPMCR) . . . . .	56
5-1	Configuration Register (CONFIG) . . . . .	60
6-1	CPU Registers . . . . .	65
6-2	Accumulator (A) . . . . .	65
6-3	Index Register (H:X) . . . . .	66
6-4	Stack Pointer (SP) . . . . .	67
6-5	Program Counter (PC) . . . . .	68
6-6	Condition Code Register (CCR) . . . . .	69
7-1	SIM Block Diagram . . . . .	83
7-2	SIM I/O Register Summary . . . . .	84
7-3	CGM Clock Signals . . . . .	85
7-4	External Reset Timing . . . . .	87
7-5	Internal Reset Timing . . . . .	88
7-6	Sources of Internal Reset . . . . .	88
7-7	POR Recovery . . . . .	89
7-8	Interrupt Entry . . . . .	92
7-9	Interrupt Processing . . . . .	93
7-10	Interrupt Recovery . . . . .	94
7-11	Interrupt Recognition Example . . . . .	95

Figure	Title	Page
7-12	Wait Mode Entry Timing . . . . .	97
7-13	Wait Recovery from Interrupt or Break. . . . .	98
7-14	Wait Recovery from Internal Reset . . . . .	98
7-15	SIM Break Status Register (SBSR) . . . . .	99
7-16	SIM Reset Status Register (SRSR) . . . . .	101
7-17	SIM Break Flag Control Register (SBFCR) . . . . .	102
8-1	CGM Block Diagram. . . . .	106
8-2	CGM I/O Register Summary . . . . .	107
8-3	CGM External Connections . . . . .	114
8-4	CGM I/O Register Summary . . . . .	116
8-5	PLL Control Register (PCTL) . . . . .	117
8-6	PLL Bandwidth Control Register (PBWC) . . . . .	119
8-7	PLL Programming Register (PPG) . . . . .	121
9-1	PWM Module Block Diagram . . . . .	131
9-2	PWMMC Register Summary . . . . .	132
9-3	Center-Aligned PWM (Positive Polarity) . . . . .	135
9-4	Edge-Aligned PWM (Positive Polarity) . . . . .	136
9-5	Reload Frequency Change . . . . .	138
9-6	PWM Interrupt Requests . . . . .	139
9-7	Center-Aligned PWM Value Loading . . . . .	140
9-8	Center-Aligned Loading of Modulus . . . . .	140
9-9	Edge-Aligned PWM Value Loading . . . . .	141
9-10	Edge-Aligned Modulus Loading . . . . .	141
9-11	Complementary Pairing . . . . .	143
9-12	Typical AC Motor Drive . . . . .	143
9-13	Dead-Time Generators. . . . .	145
9-14	Effects of Dead-Time Insertion. . . . .	147
9-15	Dead-Time at Duty Cycle Boundaries . . . . .	147
9-16	Dead-Time and Small Pulse Widths. . . . .	148
9-17	Current Convention . . . . .	149
9-18	Deadtime Distortion . . . . .	149
9-19	Sinusoidal Distortion of Load Voltage . . . . .	150
9-20	Internal Correction Logic when ISENS[1:0] = 0X . . . . .	152
9-21	Output Voltage Waveforms . . . . .	153

<b>Figure</b>	<b>Title</b>	<b>Page</b>
9-22	DTx bits . . . . .	154
9-23	Internal Correction Logic when ISENS[1:0] = 10 . . . . .	155
9-24	Internal Correction Logic when ISENS[1:0] = 11 . . . . .	155
9-25	Correction with Positive Current . . . . .	156
9-26	Correction with Negative Current . . . . .	156
9-27	PWM Polarity . . . . .	157
9-28	PWM Output Control Register (PWMOUT) . . . . .	158
9-29	Dead-Time Insertion During OUTCTL = 1 . . . . .	160
9-30	Dead-Time Insertion During OUTCTL = 1 . . . . .	160
9-31	PWM Disabling Scheme . . . . .	161
9-32	PWM Disabling Scheme . . . . .	162
9-33	PWM Disable Mapping Write-Once Register (DISMAP) . . . . .	163
9-34	PWM Disabling Decode Scheme . . . . .	164
9-35	PWM Disabling in Automatic Mode . . . . .	165
9-36	PWM Disabling in Manual Mode (Example 1) . . . . .	167
9-37	PWM Disabling in Manual Mode (Example 2) . . . . .	167
9-38	PWM Software Disable . . . . .	168
9-39	PWMEN and PWM Pins . . . . .	170
9-40	PWM Counter Registers (PCNTH:PCNTL) . . . . .	172
9-41	PWM Counter Modulo Registers (PDMODH:PMDL) . . . . .	173
9-42	PWM X Value Registers (PVALXH:PVALXL) . . . . .	174
9-43	PWM Control Register 1 (PCTL1) . . . . .	175
9-44	PWM Control Register 2 (PCTL2) . . . . .	177
9-45	Dead-Time Write-Once Register (DEADTM) . . . . .	179
9-46	PWM Disable Mapping Write-Once Register (DISMAP) . . . . .	180
9-47	Fault Control Register (FCR) . . . . .	180
9-48	Fault Status Register (FSR) . . . . .	183
9-49	Fault Acknowledge Register (FTACK) . . . . .	185
9-50	PWM Output Control Register (PWMOUT) . . . . .	186
9-51	PWM Clock Cycle and PWM Cycle Definitions . . . . .	188
9-52	PWM Load Cycle/Frequency Definition . . . . .	189
10-1	Monitor Mode Circuit . . . . .	193
10-2	Monitor Data Format . . . . .	195

## List of Figures

Figure	Title	Page
10-3	Sample Monitor Waveforms . . . . .	195
10-4	Read Transaction . . . . .	196
10-5	Break Transaction . . . . .	196
11-1	TIMA Block Diagram . . . . .	203
11-2	TIMA I/O Register Summary . . . . .	204
11-3	PWM Period and Pulse Width . . . . .	208
11-4	TIMA Status and Control Register (TASC) . . . . .	215
11-5	TIMA Counter Registers (TACNTH:TACNTL) . . . . .	217
11-6	TIMA Counter Modulo Registers (TAMODH:TAMODL) . . . . .	218
11-7	TIMA Channel Status and Control Registers (TASC0:TASC1) . . . . .	219
11-8	CHxMAX Latency . . . . .	222
11-9	TIMA Channel Registers (TACH0H/L:TACH1H/L) . . . . .	223
12-1	TIMB Block Diagram . . . . .	227
12-2	TIMB I/O Register Summary . . . . .	228
12-3	PWM Period and Pulse Width . . . . .	233
12-4	TIMB Status and Control Register (TBSC) . . . . .	240
12-5	TIMB Counter Registers (TBCNTH:TBCNTL) . . . . .	242
12-6	TIMB Counter Modulo Registers (TBMODH:TBMODL) . . . . .	243
12-7	TIMB Channel Status and Control Registers (TBSC0:TBSC3) . . . . .	244
12-8	CHxMAX Latency . . . . .	248
12-9	TIMB Channel Registers (TBCH0H/L:TBCH3H/L) . . . . .	248
13-1	SPI Module Block Diagram . . . . .	254
13-2	SPI I/O Register Summary . . . . .	255
13-3	Full-Duplex Master-Slave Connections . . . . .	256
13-4	Transmission Format (CPHA = 0) . . . . .	259
13-5	CPHA/ $\overline{SS}$ Timing . . . . .	259
13-6	Transmission Format (CPHA = 1) . . . . .	260
13-7	Transmission Start Delay (Master) . . . . .	262
13-8	SPRF/SPTC CPU Interrupt Timing . . . . .	263

<b>Figure</b>	<b>Title</b>	<b>Page</b>
13-9	Missed Read of Overflow Condition . . . . .	265
13-10	Clearing SPRF When OVRF Interrupt Is Not Enabled . . . . .	266
13-11	SPI Interrupt Request Generation . . . . .	270
13-12	CPHA/ $\overline{SS}$ Timing . . . . .	275
13-13	SPI Control Register (SPCR) . . . . .	277
13-14	SPI Status and Control Register (SPSCR) . . . . .	279
13-15	SPI Data Register (SPDR) . . . . .	282
14-1	SCI Module Block Diagram . . . . .	286
14-2	SCI I/O Register Summary . . . . .	287
14-3	SCI Data Formats . . . . .	288
14-4	SCI Transmitter . . . . .	290
14-5	SCI Receiver Block Diagram . . . . .	293
14-6	Receiver Data Sampling . . . . .	295
14-7	SCI Control Register 1 (SCC1) . . . . .	301
14-8	SCI Control Register 2 (SCC2) . . . . .	304
14-9	SCI Control Register 3 (SCC3) . . . . .	307
14-10	SCI Status Register 1 (SCS1) . . . . .	309
14-11	Flag Clearing Sequence . . . . .	312
14-12	SCI Status Register 2 (SCS2) . . . . .	313
14-13	SCI Data Register (SCDR) . . . . .	314
14-14	SCI Baud Rate Register (SCBR) . . . . .	314
15-1	I/O Port Register Summary . . . . .	318
15-2	Port A Data Register (PTA) . . . . .	320
15-3	Data Direction Register A (DDRA) . . . . .	320
15-4	Port A I/O Circuit . . . . .	321
15-5	Port B Data Register (PTB) . . . . .	322
15-6	Data Direction Register B (DDRB) . . . . .	322
15-7	Port B I/O Circuit . . . . .	323
15-8	Port C Data Register (PTC) . . . . .	324
15-9	Data Direction Register C (DDRC) . . . . .	325
15-10	Port C I/O Circuit . . . . .	325
15-11	Port D Data Register (PTD) . . . . .	326
15-12	Port D Input Circuit . . . . .	327
15-13	Port E Data Register (PTE) . . . . .	328

## List of Figures

Figure	Title	Page
15-14	Data Direction Register E (DDRE) . . . . .	329
15-15	Port E I/O Circuit . . . . .	329
15-16	Port F Data Register (PTF) . . . . .	330
15-17	Data Direct Register F (DDRF) . . . . .	331
15-18	Port F I/O Circuit. . . . .	332
16-1	COP Block Diagram . . . . .	334
16-2	COP I/O Register Summary . . . . .	334
16-3	COP Control Register (COPCTL). . . . .	336
17-1	IRQ Module Block Diagram . . . . .	340
17-2	IRQ I/O Register Summary . . . . .	340
17-3	IRQ Interrupt Flowchart . . . . .	342
17-4	IRQ Status and Control Register (ISCR) . . . . .	345
18-1	LVI Module Block Diagram. . . . .	348
18-2	LVI I/O Register Summary . . . . .	349
18-3	LVI Status Register (LVISR). . . . .	350
19-1	ADC Block Diagram . . . . .	355
19-2	ADC Status and Control Register (ADSCR). . . . .	360
19-3	ADC Data Register (ADR) . . . . .	363
19-4	ADC Clock Register (ADCLKR) . . . . .	363
20-1	POR Block Diagram . . . . .	366
21-1	SPI Master Timing . . . . .	373
21-2	SPI Slave Timing . . . . .	374
22-1	MC68HC708MP16FU (Case #840B-01) . . . . .	380



## List of Tables

Table	Title	Page
2-1	Vector Addresses .....	51
6-1	Instruction Set Summary .....	72
6-2	Opcode Map.....	80
7-1	Signal Name Conventions .....	84
7-2	PIN Bit Set Timing.....	87
8-1	VCO Frequency Multiplier (N) Selection .....	122
9-1	PWM Prescaler .....	137
9-2	PWM Reload Frequency .....	138
9-3	PWM Data Overflow and Underflow Conditions.....	142
9-4	Correction Method Selection .....	151
9-5	Top/Bottom Manual Correction .....	152
9-6	Top/Bottom Current-Sense Correction.....	154
9-7	OUTx Bits .....	158
9-8	Correction Methods.....	176
9-9	PWM Reload Frequency .....	178
9-10	PWM Prescaler .....	179
9-11	OUTx Bits .....	187
10-1	Mode Selection .....	194
10-2	Mode Differences .....	195
10-3	READ (Read Memory) Command.....	197
10-4	WRITE (Write Memory) Command .....	198
10-5	IREAD (Indexed Read) Command .....	198
10-6	IWRITE (Indexed Write) Command.....	199
10-7	READSP (Read Stack Pointer) Command.....	199

## List of Tables

Table	Title	Page
10-8	RUN (Run User Program) Command.....	200
10-9	Monitor Baud Rate Selection.....	200
11-1	Prescaler Selection .....	216
11-2	Mode, Edge, and Level Selection.....	221
12-1	Prescaler Selection .....	241
12-2	Mode, Edge, and Level Selection.....	247
13-1	Pin Name Conventions.....	253
13-2	SPI Interrupts .....	269
13-3	SPI Configuration .....	276
13-4	SPI Master Baud Rate Selection.....	281
14-1	Start Bit Verification.....	295
14-2	Data Bit Recovery .....	296
14-3	Stop Bit Recovery.....	296
14-4	Character Format Selection .....	303
14-5	SCI Baud Rate Prescaling.....	315
14-6	SCI Baud Rate Selection.....	315
14-7	SCI Baud Rate Selection Examples.....	316
15-1	Port A Pin Functions.....	321
15-2	Port B Pin Functions.....	323
15-3	Port C Pin Functions .....	326
15-4	Port D Pin Functions .....	327
15-5	Port E Pin Functions.....	330
15-6	Port F Pin Functions.....	332
18-1	LVIOUT Bit Indication.....	350
19-1	Mux Channel Select .....	362
19-2	ADC Clock Divide Ratio .....	364
21-1	Absolute Maximum Ratings.....	368
21-2	Operating Range .....	369

<b>Table</b>	<b>Title</b>	<b>Page</b>
21-3	Thermal Characteristics .....	369
21-4	DC Electrical Characteristics ( $V_{DD} = 5.0 \text{ Vdc} \pm 10\%$ ) .....	370
21-5	Control Timing ( $V_{DD} = 5.0 \text{ Vdc} \pm 10\%$ ).....	371
21-6	Serial Peripheral Interface (SPI) Timing ( $V_{DD} = 5.0 \text{ Vdc} \pm 10\%$ ) .....	372
21-7	TIM Timing .....	375
21-8	CGM Component Specifications .....	375
21-9	CGM Operating Conditions .....	375
21-10	CGM Acquisition/Lock Time Specifications.....	376
21-11	ADC Characteristics .....	377
21-12	Memory Characteristics.....	377
23-1	MC Order Numbers .....	383



## Section 1. General Description

### 1.1 Contents

1.2	Introduction	30
1.3	Features	30
1.4	MCU Block Diagram	31
1.5	Pin Assignments	33
1.5.1	Power Supply Pins ( $V_{DD}$ and $V_{SS}$ )	34
1.5.2	Oscillator Pins (OSC1 and OSC2)	34
1.5.3	External Reset Pin ( $\overline{RST}$ )	34
1.5.4	External Interrupt Pin ( $\overline{IRQ1}/V_{PP}$ )	35
1.5.5	CGM Power Supply Pins ( $V_{DDA}$ and $V_{SSA}$ )	35
1.5.6	External Filter Capacitor Pin (CGMXFC)	35
1.5.7	Analog Power Supply Pins ( $V_{DDAD}/V_{DDAREF}$ and $V_{SSAD}$ )	35
1.5.8	ADC Voltage Decoupling Capacitor Pin ( $V_{ADCAP}$ )	35
1.5.9	ADC Voltage Reference Low Pin (VREFL)	36
1.5.10	Port A Input/Output (I/O) Pins (PTA7–PTA0)	36
1.5.11	Port B I/O Pins (PTB7/ATD7–PTB0/ATD0)	36
1.5.12	Port C I/O Pins (PTC6–PTC2 and PTC1/ATD9–PTC0/ATD8)	36
1.5.13	Port D Input-Only Pins (PTD6/ $\overline{IS3}$ –PTD4/ $\overline{IS1}$ and PTD3/FAULT4–PTD0/FAULT1)	36
1.5.14	PWM Pins (PWM6–PWM1)	37
1.5.15	PWM Ground Pin (PWMGND)	37
1.5.16	Port E I/O Pins (PTE7/TCH3B–PTE3/TCLKB and PTE2/TCH1A–PTE0/TCLKA)	37
1.5.17	Port F I/O Pins (PTF5/TxD–PTF4/RxD and PTF3/MISO–PTF0/SPSCK)	37

## 1.2 Introduction

The MC68HC708MP16 is a member of the low-cost, high-performance M68HC08 Family of 8-bit microcontroller units (MCUs). The M68HC08 Family is based on the customer-specified integrated circuit (CSIC) design strategy. All MCUs in the family use the enhanced M68HC08 central processor unit (CPU08) and are available with a variety of modules, memory sizes and types, and package types.

## 1.3 Features

Features of the MC68HC708MP16 include:

- High-performance M68HC08 architecture
- Fully upward-compatible object code with M6805, M146805, and M68HC05 Families
- 8-MHz internal bus frequency
- 16 Kbytes of on-chip erasable programmable read-only memory (EPROM) or one-time programmable read-only memory (OTPROM)
- On-chip programming firmware for use with host personal computer
- EPROM/OTPROM data security<sup>1</sup>
- 512 bytes of on-chip RAM
- 12-bit, 6-channel center-aligned or edge-aligned pulse width modulator (PWMMC)
- 64-pin plastic quad flat pack (QFP)
- Serial peripheral interface module (SPI)
- Serial communications interface module (SCI)
- 16-bit, 2-channel timer interface module (TIMA)
- 16-bit, 4-channel timer interface module (TIMB)

---

1. No security feature is absolutely secure. However, Freescale's strategy is to make reading or copying the EPROM/OTPROM difficult for unauthorized users.

- Clock Generator module (CGM)
- Digitally filtered low-voltage inhibit (LVI45)
- 8-bit, 10-channel analog-to-digital convertor (ADC)
- System protection features:
  - Optional computer operating properly (COP) reset
  - Low-voltage detection with optional reset
  - Illegal opcode detection with optional reset
  - Illegal address detection with optional reset
  - Fault detection with optional PWM disabling
- Low-power design (fully static with wait mode)
- Master reset pin and power-on reset

Features of the CPU08 include:

- Enhanced HC05 programming model
- Extensive loop control functions
- 16 addressing modes (eight more than the HC05)
- 16-bit index register and stack pointer
- Memory-to-memory data transfers
- Fast  $8 \times 8$  multiply instruction
- Fast 16/8 divide instruction
- Binary-coded decimal (BCD) instructions
- Optimization for controller applications
- C language support

## 1.4 MCU Block Diagram

**Figure 1-1** shows the structure of the MC68HC708MP16.

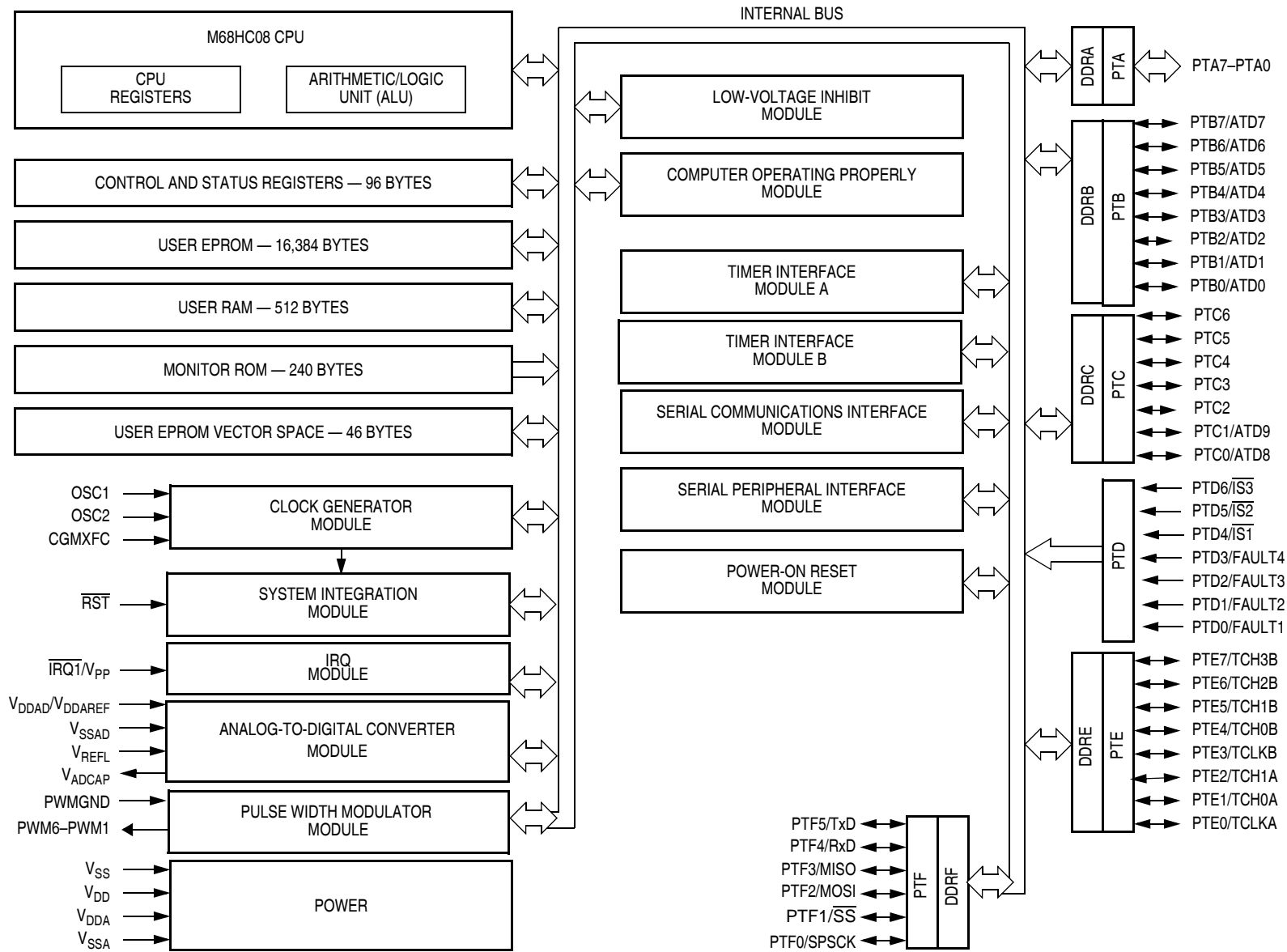


Figure 1-1. MCU Block Diagram



## 1.5 Pin Assignments

Figure 1-2 shows the QFP pin assignments.

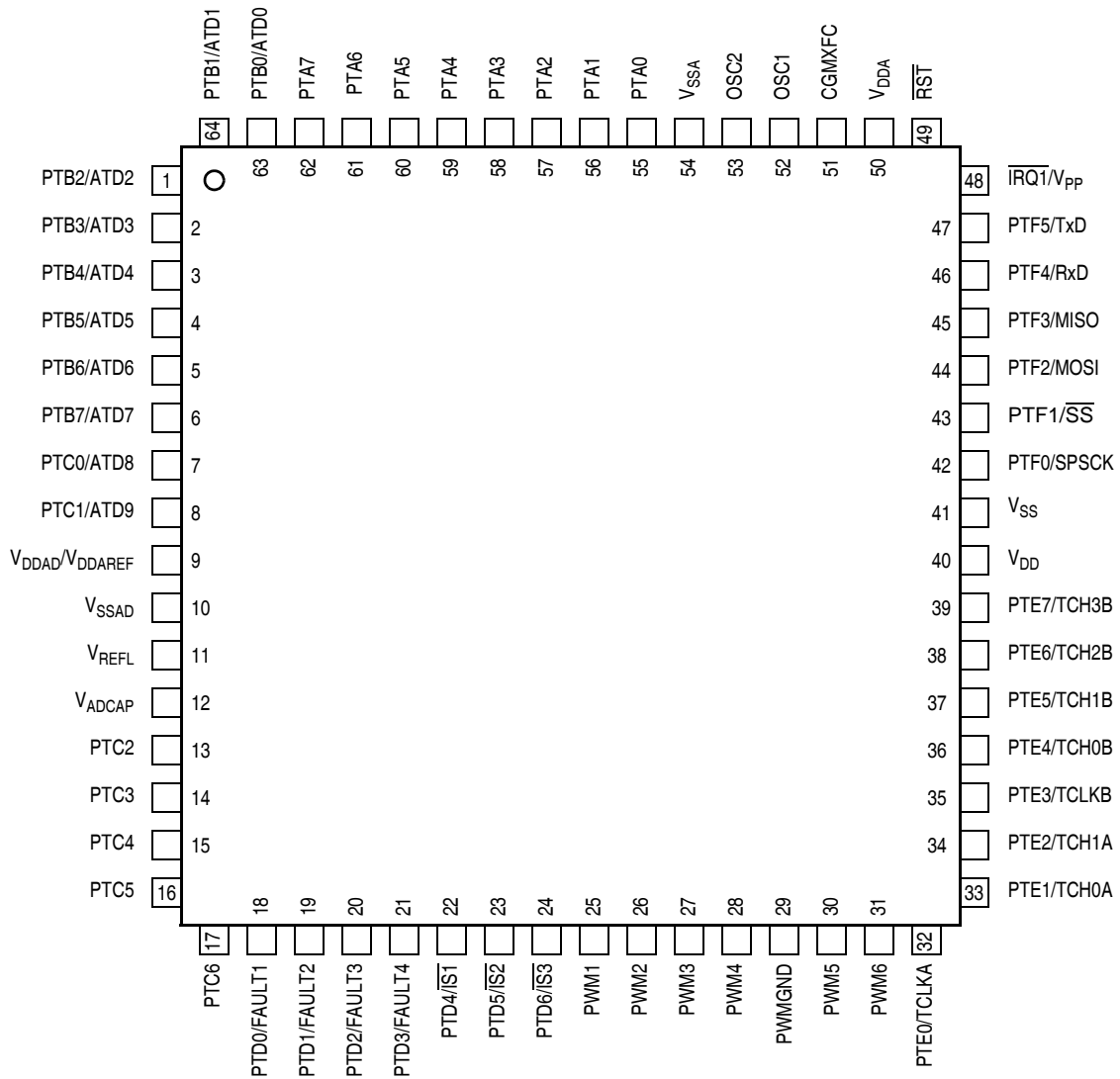


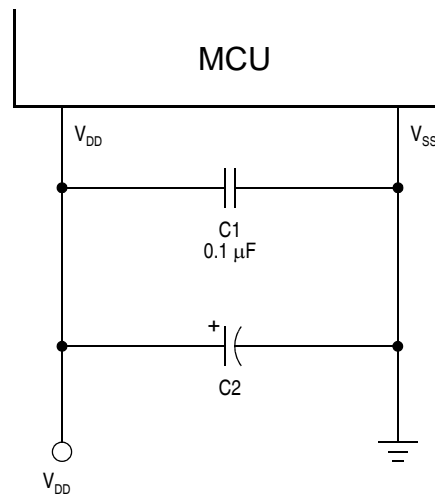
Figure 1-2. QFP Pin Assignments

## General Description

### 1.5.1 Power Supply Pins ( $V_{DD}$ and $V_{SS}$ )

$V_{DD}$  and  $V_{SS}$  are the power supply and ground pins. The MCU operates from a single power supply.

Fast signal transitions on MCU pins place high, short-duration current demands on the power supply. To prevent noise problems, take special care to provide power supply bypassing at the MCU as [Figure 1-3](#) shows. Place the C1 bypass capacitor as close to the MCU as possible. Use a high-frequency-response ceramic capacitor for C1. C2 is an optional bulk current bypass capacitor for use in applications that require the port pins to source high current levels.



Note: Component values shown represent typical applications.

**Figure 1-3. Power Supply Bypassing**

### 1.5.2 Oscillator Pins (OSC1 and OSC2)

The OSC1 and OSC2 pins are the connections for the on-chip oscillator circuit. (See [Section 8. Clock Generator Module \(CGM\)](#).)

### 1.5.3 External Reset Pin ( $\overline{RST}$ )

A logic 0 on the  $\overline{RST}$  pin forces the MCU to a known start-up state.  $\overline{RST}$  is bidirectional, allowing a reset of the entire system. It is driven low when

any internal reset source is asserted. (See [Section 7. System Integration Module \(SIM\)](#).)

#### 1.5.4 External Interrupt Pin ( $\overline{\text{IRQ1}}/V_{\text{PP}}$ )

$\overline{\text{IRQ1}}/V_{\text{PP}}$  is an asynchronous external interrupt pin. (See [Section 17. External Interrupt \(IRQ\)](#).)  $\overline{\text{IRQ1}}/V_{\text{PP}}$  is also the EPROM/OTPROM programming power pin. (See [Section 2. Memory Map](#).)

#### 1.5.5 CGM Power Supply Pins ( $V_{\text{DDA}}$ and $V_{\text{SSA}}$ )

$V_{\text{DDA}}$  and  $V_{\text{SSA}}$  are the power supply pins for the analog portion of the clock generator module (CGM). Decoupling of these pins should be as per the digital supply. (See [Section 8. Clock Generator Module \(CGM\)](#).)

#### 1.5.6 External Filter Capacitor Pin (CGMXFC)

CGMXFC is an external filter capacitor connection for the CGM. (See [Section 8. Clock Generator Module \(CGM\)](#).)

#### 1.5.7 Analog Power Supply Pins ( $V_{\text{DDAD}}/V_{\text{DDAREF}}$ and $V_{\text{SSAD}}$ )

$V_{\text{DDAD}}/V_{\text{DDAREF}}$  and  $V_{\text{SSAD}}$  are the power supply pins for the analog-to-digital converter. Decoupling of these pins should be as per the digital supply. (See [Section 19. Analog-to-Digital Converter \(ADC\)](#).)

#### 1.5.8 ADC Voltage Decoupling Capacitor Pin ( $V_{\text{ADCAP}}$ )

$V_{\text{ADCAP}}$  is one of two reference supplies and is generated from  $V_{\text{DDAREF}}$  with a value  $(V_{\text{DDAREF}})/2$ . Place a bypass capacitor on this pin to decouple noise. (See [Section 19. Analog-to-Digital Converter \(ADC\)](#).)

### 1.5.9 ADC Voltage Reference Low Pin ( $V_{REFL}$ )

$V_{REFL}$  is the lower reference supply for the ADC. Connect the  $V_{REFL}$  pin to the same voltage potential as  $V_{SSA}$ . (See [Section 19. Analog-to-Digital Converter \(ADC\)](#).)

### 1.5.10 Port A Input/Output (I/O) Pins (PTA7–PTA0)

PTA7–PTA0 are general-purpose bidirectional I/O port pins. (See [Section 15. Input/Output \(I/O\) Ports](#).)

### 1.5.11 Port B I/O Pins (PTB7/ATD7–PTB0/ATD0)

Port B is an 8-bit special function port that shares all eight pins with the analog-to-digital convertor (ADC). (See [Section 19. Analog-to-Digital Converter \(ADC\)](#) and [Section 15. Input/Output \(I/O\) Ports](#).)

### 1.5.12 Port C I/O Pins (PTC6–PTC2 and PTC1/ATD9–PTC0/ATD8)

PTC6–PTC2 are general-purpose bidirectional I/O port pins. (See [Section 15. Input/Output \(I/O\) Ports](#).) PTC1/ATD9–PTC0/ATD8 are special function port pins that are shared with the analog-to-digital convertor (ADC). (See [Section 19. Analog-to-Digital Converter \(ADC\)](#) and [Section 15. Input/Output \(I/O\) Ports](#).)

### 1.5.13 Port D Input-Only Pins (PTD6/ $\overline{IS3}$ –PTD4/ $\overline{IS1}$ and PTD3/FAULT4–PTD0/FAULT1)

PTD6/ $\overline{IS3}$ –PTD4/ $\overline{IS1}$  are special function input-only port pins that also serve as current sensing pins for the pulse width modulator module (PWMMC). PTD3/FAULT4–PTD0/FAULT1 are special function port pins that also serve as fault pins for the pulse width modulator module (PWMMC). (See [Section 9. Pulse Width Modulator for Motor Control \(PWMMC\)](#) and [Section 15. Input/Output \(I/O\) Ports](#).)

#### 1.5.14 PWM Pins (PWM6–PWM1)

PWM6–PWM1 are dedicated pins used for the outputs of the pulse width modulator module (PWMMC). These are high current pins capable of 20 mA sink ( $V_{OL} = 0.8 \text{ V}$ ) and 7 mA ( $V_{OH} = V_{DD} - 0.8 \text{ V}$ ) source. (See [Section 9. Pulse Width Modulator for Motor Control \(PWMMC\)](#) and [Section 21. Electrical Specifications](#).)

#### 1.5.15 PWM Ground Pin (PWMGND)

PWMGND is the ground pin for the pulse width modulator module (PWMMC). This dedicated ground pin is used as the ground for the six high current PWM pins. (See [Section 9. Pulse Width Modulator for Motor Control \(PWMMC\)](#).)

#### 1.5.16 Port E I/O Pins (PTE7/TCH3B–PTE3/TCLKB and PTE2/TCH1A–PTE0/TCLKA)

Port E is an 8-bit special function port that shares its pins with the two timer interface modules (TIMA and TIMB). (See [Section 11. Timer Interface Module A \(TIMA\)](#), [Section 12. Timer Interface Module B \(TIMB\)](#), and [Section 15. Input/Output \(I/O\) Ports](#).)

#### 1.5.17 Port F I/O Pins (PTF5/TxD–PTF4/RxD and PTF3/MISO–PTF0/SPSCK)

Port F is a 6-bit special function port that shares two of its pins with the serial communications interface module (SCI) and four of its pins with the serial peripheral interface module (SPI). (See [Section 13. Serial Peripheral Interface Module \(SPI\)](#), [Section 14. Serial Communications Interface Module \(SCI\)](#), and [Section 15. Input/Output \(I/O\) Ports](#).)



## Section 2. Memory Map

### 2.1 Contents

2.2	Introduction .....	39
2.3	Input/Output (I/O) Section .....	41
2.4	Monitor ROM .....	52

### 2.2 Introduction

The CPU08 can address 64 Kbytes of memory space. The memory map, shown in [Figure 2-1](#), includes:

- 16 Kbytes of EPROM or OTPROM
- 512 bytes of RAM
- 46 bytes of user-defined vectors
- 240 bytes of monitor ROM

# Memory Map

\$0000 ↓	I/O REGISTERS (96 BYTES)
\$004F ↓	RAM (512 BYTES)
\$024F ↓	UNIMPLEMENTED (48,048 BYTES)
\$BDFF ↓	EPROM (16,384 BYTES)
\$FE00	SIM BREAK STATUS REGISTER (SBSR)
\$FE01	SIM RESET STATUS REGISTER (SRSR)
\$FE02	RESERVED
\$FE03	SIM BREAK FLAG CONTROL REGISTER (SBFCR)
\$FE04	RESERVED
\$FE05	RESERVED
\$FE06	RESERVED
\$FE07	EPROM CONTROL REGISTER (EPMCR)
\$FE08	UNIMPLEMENTED
\$FE09	UNIMPLEMENTED
\$FE0A	UNIMPLEMENTED
\$FE0B	PLL CONTROL REGISTER
\$FE0C	PLL BANDWIDTH CONTROL REGISTER
\$FE0D	PLL PROGRAMMING AND CONTROL REGISTER
\$FE0E	UNIMPLEMENTED
\$FE0F	LVI STATUS REGISTER (LVISR)
\$FE10 ↓	MONITOR ROM (240 BYTES)
\$FEFF ↓	UNIMPLEMENTED (192 BYTES)
\$FFBF ↓	RESERVED (18 BYTES)
\$FFD1 ↓	VECTORS (46 BYTES)
\$FFFF	

**Figure 2-1. Memory Map**



## 2.3 Input/Output (I/O) Section

Addresses \$0000–\$004F, shown in [Figure 2-2](#), contain most of the control, status, and data registers. Additional I/O registers have these addresses:

- \$FE00 — SIM break status register, SBSR
- \$FE01 — SIM reset status register, SRSR
- \$FE03 — SIM break flag control register, SBFCR
- \$FE07 — EPROM control register, EPMCR
- \$FE0B — PLL control register
- \$FE0C — PLL bandwidth control register
- \$FE0D — PLL programming register
- \$FE0F — LVI status register, LVISR
- \$FFFF — COP control register, COPCTL

# Memory Map

Addr.	Name	Bit 7	6	5	4	3	2	1	Bit 0	
\$0000	Port A Data Register (PTA) See <a href="#">page 320</a> .	Read:	PTA7	PTA6	PTA5	PTA4	PTA3	PTA2	PTA1	PTA0
		Write:								
		Reset:	Unaffected by reset							
\$0001	Port B Data Register (PTB) See <a href="#">page 322</a> .	Read:	PTB7	PTB6	PTB5	PTB4	PTB3	PTB2	PTB1	PTB0
		Write:								
		Reset:	Unaffected by reset							
\$0002	Port C Data Register (PTC) See <a href="#">page 324</a> .	Read:	0	PTC6	PTC5	PTC4	PTC3	PTC2	PTC1	PTC0
		Write:								
		Reset:	Unaffected by reset							
\$0003	Port D Data Register (PTD) See <a href="#">page 326</a> .	Read:	0	PTD6	PTD5	PTD4	PTD3	PTD2	PTD1	PTD0
		Write:								
		Reset:	Unaffected by reset							
\$0004	Port E Data Register (PTE) See <a href="#">page 328</a> .	Read:	PTE7	PTE6	PTE5	PTE4	PTE3	PTE2	PTE1	PTE0
		Write:								
		Reset:	Unaffected by reset							
\$0005	Port F Data Register (PTF) See <a href="#">page 330</a> .	Read:	0	0	PTF5	PTF4	PTF3	PTF2	PTF1	PTF0
		Write:								
		Reset:	Unaffected by reset							
\$0006	Data Direction Register A (DDRA) See <a href="#">page 320</a> .	Read:	DDRA7	DDRA6	DDRA5	DDRA4	DDRA3	DDRA2	DDRA1	DDRA0
		Write:								
		Reset:	0	0	0	0	0	0	0	0
\$0007	Data Direction Register B (DDRB) See <a href="#">page 322</a> .	Read:	DDRB7	DDRB6	DDRB5	DDRB4	DDRB3	DDRB2	DDRB1	DDRB0
		Write:								
		Reset:	0	0	0	0	0	0	0	0
\$0008	Data Direction Register C (DDRC) See <a href="#">page 325</a> .	Read:	0	DDRC6	DDRC5	DDRC4	DDRC3	DDRC2	DDRC1	DDRC0
		Write:								
		Reset:	0	0	0	0	0	0	0	0
\$0009	Unimplemented	Read:								
		Write:								

X = Indeterminate    U = Unaffected     = Unimplemented    R = Reserved

**Figure 2-2. Control, Status, and Data Registers (Sheet 1 of 9)**

Addr.	Name	Bit 7	6	5	4	3	2	1	Bit 0	
\$000A	Data Direction Register E (DDRE) See page 329.	Read:	DDRE7	DDRE6	DDRE5	DDRE4	DDRE3	DDRE2	DDRE1	DDRE0
		Write:								
		Reset:	0	0	0	0	0	0	0	0
\$000B	Data Direction Register F (DDRF) See page 331.	Read:	0	0	DDRF5	DDRF4	DDRF3	DDRF2	DDRF1	DDRF0
		Write:								
		Reset:	0	0	0	0	0	0	0	0
\$000C	Timer A Status and Control Register (TASC) See page 215.	Read:	TOF	TOIE	TSTOP	0	0	PS2	PS1	PS0
		Write:	0			TRST				
		Reset:	0	0	1	0	0	0	0	0
\$000D	Timer A Counter Register High (TACNTH) See page 217.	Read:	Bit 15	14	13	12	11	10	9	Bit 8
		Write:								
		Reset:	0	0	0	0	0	0	0	0
\$000E	Timer A Counter Register Low (TACNTL) See page 217.	Read:	Bit 7	6	5	4	3	2	1	Bit 0
		Write:								
		Reset:	0	0	0	0	0	0	0	0
\$000F	Timer A Modulo Register High (TAMODH) See page 218.	Read:	Bit 15	14	13	12	11	10	9	Bit 8
		Write:								
		Reset:	1	1	1	1	1	1	1	1
\$0010	Timer A Modulo Register Low (TAMODL) See page 218.	Read:	Bit 7	6	5	4	3	2	1	Bit 0
		Write:								
		Reset:	1	1	1	1	1	1	1	1
\$0011	Timer A Channel 0 Status and Control Register (TASC0) See page 219.	Read:	CH0F	CH0IE	MS0B	MS0A	ELS0B	ELS0A	TOV0	CH0MAX
		Write:	0							
		Reset:	0	0	0	0	0	0	0	0
\$0012	Timer A Channel 0 Register High (TACH0H) See page 223.	Read:	Bit 15	14	13	12	11	10	9	Bit 8
		Write:								
		Reset:	Indeterminate after reset							
\$0013	Timer A Channel 0 Register Low (TACH0L) See page 223.	Read:	Bit 7	6	5	4	3	2	1	Bit 0
		Write:								
		Reset:	Indeterminate after reset							

X = Indeterminate    U = Unaffected     = Unimplemented    R = Reserved

**Figure 2-2. Control, Status, and Data Registers (Sheet 2 of 9)**

# Memory Map

Addr.	Name	Bit 7	6	5	4	3	2	1	Bit 0	
\$0014	Timer A Channel 1 Status and Control Register (TASC1) See page 223.	Read:	CH1F	CH1IE	0	MS1A	ELS1B	ELS1A	TOV1	CH1MAX
		Write:	0							
		Reset:	0	0	0	0	0	0	0	0
\$0015	Timer A Channel 1 Register High (TACH1H) See page 223.	Read:	Bit 15	14	13	12	11	10	9	Bit 8
		Write:								
		Reset:	Indeterminate after reset							
\$0016	Timer A Channel 1 Register Low (TACH1L) See page 223.	Read:	Bit 7	6	5	4	3	2	1	Bit 0
		Write:								
		Reset:	Indeterminate after reset							
\$0017	ADC Status and Control Register (ADSCR)	Read:	COCO/ IDMAS	AIEN	ADCO	ADCH4	ADCH3	ADCH2	ADCH1	ADCH0
		Write:								
		Reset:	0	0	0	0	0	0	0	0
\$0018	Unimplemented	Read:								
		Write:								
		Reset:								
\$0019	ADC Data Register (ADR) See page 363.	Read:	AD7	AD6	AD5	AD4	AD3	AD2	AD1	AD0
		Write:								
		Reset:	0	0	0	0	0	0	0	0
\$001A	ADC Clock Register (ADCLK) See page 363.	Read:	ADIV2	ADIV1	ADIV0	ADCLK	0	0	0	0
		Write:								
		Reset:	0	0	0	0	0	0	0	0
\$001B	SPI Control Register (SPCR) See page 277.	Read:	SPRIE	DMAS	SPMSTR	CPOL	CPHA	SPWOM	SPE	SPTIE
		Write:								
		Reset:	0	0	1	0	1	0	0	0
\$001C	SPI Status and Control Register (SPSCR) See page 279.	Read:	SPRF	ERRIE	OVRF	MODF	SPTIE	MODFEN	SPR1	SPR0
		Write:								
		Reset:	0	0	0	0	1	0	0	0
\$001D	SPI Data Register (SPDR) See page 282.	Read:	R7	R6	R5	R4	R3	R2	R1	R0
		Write:	T7	T6	T5	T4	T3	T2	T1	T0
		Reset:	Indeterminate after reset							

X = Indeterminate    U = Unaffected     = Unimplemented    R = Reserved

**Figure 2-2. Control, Status, and Data Registers (Sheet 3 of 9)**

Addr.	Name		Bit 7	6	5	4	3	2	1	Bit 0
\$001E	IRQ Status and Control Register (ISCR) See page 345.	Read:	0	0	0	0	IRQ1F	0	IMASK1	MODE1
		Write:						ACK1		
		Reset:	0	0	0	0	0	0	0	0
\$001F	Configuration Write-Once Register (CONFIG) See page 60.	Read:	EDGE	BOTNEG	TOPNEG	INDEP	LVIRST	LVIPWR	Bit 1	COPD
		Write:								
		Reset:	0	0	0	0	0	0	0	0
\$0020	PWM Control Register 1 (PCTL1) See page 175.	Read:	DISX	DISY	PWMINT	PWMF	ISENS1	ISENS0	LDOK	PWMEN
		Write:								
		Reset:	0	0	0	0	0	0	0	0
\$0021	PWM Control Register 2 (PCTL2) See page 177.	Read:	LDFQ1	LDFQ0	0	IPOL1	IPOL2	IPOL3	PRSC1	PRSC0
		Write:								
		Reset:	0	0	0	0	0	0	0	0
\$0022	Fault Control Register (FCR) See page 180.	Read:	FINT4	FMODE4	FINT3	FMODE3	FINT2	FMODE2	FINT1	FMODE1
		Write:								
		Reset:	0	0	0	0	0	0	0	0
\$0023	Fault Status Register (FSR) See page 183.	Read:	FPIN4	FFLAG4	FPIN3	FFLAG3	FPIN2	FFLAG2	FPIN1	FFLAG1
		Write:								
		Reset:	U	0	U	0	U	0	U	0
\$0024	Fault Acknowledge Register (FTACK) See page 185.	Read:	0	0	DT6	DT5	DT4	DT3	DT2	DT1
		Write:		FTACK4		FTACK3		FTACK2		FTACK1
		Reset:	0	0	0	0	0	0	0	0
\$0025	PWM Output Control (PWMOUT) See page 186.	Read:	0	OUTCTL	OUT6	OUT5	OUT4	OUT3	OUT2	OUT1
		Write:								
		Reset:	0	0	0	0	0	0	0	0
\$0026	PWM Counter Register High (PCNTH) See page 172.	Read:	0	0	0	0	11	10	9	Bit 8
		Write:								
		Reset:	0	0	0	0	0	0	0	0
\$0027	PWM Counter Register Low (PCNTL) See page 172.	Read:	Bit 7	6	5	4	3	2	1	Bit 0
		Write:								
		Reset:	0	0	0	0	0	0	0	0

X = Indeterminate    U = Unaffected     = Unimplemented    R = Reserved

Figure 2-2. Control, Status, and Data Registers (Sheet 4 of 9)

# Memory Map

Addr.	Name	Bit 7	6	5	4	3	2	1	Bit 0	
\$0028	PWM Counter Modulo Register High (PMODH) See <a href="#">page 173</a> .	Read:	0	0	0	0	11	10	9	Bit 8
		Write:								
		Reset:	0	0	0	0	X	X	X	X
\$0029	PWM Counter Modulo Register Low (PMODL) See <a href="#">page 173</a> .	Read:	Bit 7	6	5	4	3	2	1	Bit 0
		Write:								
		Reset:	X	X	X	X	X	X	X	X
\$002A	PWM 1 Value Register High (PVAL1H) See <a href="#">page 174</a> .	Read:	Bit 15	14	13	12	11	10	9	Bit 8
		Write:								
		Reset:	0	0	0	0	0	0	0	0
\$002B	PWM 1 Value Register Low (PVAL1L) See <a href="#">page 174</a> .	Read:	Bit 7	6	5	4	3	2	1	Bit 0
		Write:								
		Reset:	0	0	0	0	0	0	0	0
\$002C	PWM 2 Value Register High (PVAL2H) See <a href="#">page 174</a> .	Read:	Bit 15	14	13	12	11	10	9	Bit 8
		Write:								
		Reset:	0	0	0	0	0	0	0	0
\$002D	PWM 2 Value Register Low (PVAL2L) See <a href="#">page 174</a> .	Read:	Bit 7	6	5	4	3	2	1	Bit 0
		Write:								
		Reset:	0	0	0	0	0	0	0	0
\$002E	PWM 3 Value Register High (PVAL3H) See <a href="#">page 174</a> .	Read:	Bit 15	14	13	12	11	10	9	Bit 8
		Write:								
		Reset:	0	0	0	0	0	0	0	0
\$002F	PWM 3 Value Register Low (PVAL3L) See <a href="#">page 174</a> .	Read:	Bit 7	6	5	4	3	2	1	Bit 0
		Write:								
		Reset:	0	0	0	0	0	0	0	0
\$0030	PWM 4 Value Register High (PVAL4H) See <a href="#">page 174</a> .	Read:	Bit 15	14	13	12	11	10	9	Bit 8
		Write:								
		Reset:	0	0	0	0	0	0	0	0
\$0031	PWM 4 Value Register Low (PVAL4L) See <a href="#">page 174</a> .	Read:	Bit 7	6	5	4	3	2	1	Bit 0
		Write:								
		Reset:	0	0	0	0	0	0	0	0

X = Indeterminate    U = Unaffected     = Unimplemented    R = Reserved

**Figure 2-2. Control, Status, and Data Registers (Sheet 5 of 9)**

Addr.	Name	Bit 7	6	5	4	3	2	1	Bit 0	
\$0032	PWM 5 Value Register High (PVAL5H) See <a href="#">page 174</a> .	Read:	Bit 15	14	13	12	11	10	9	Bit 8
		Write:								
		Reset:	0	0	0	0	0	0	0	0
\$0033	PWM 5 Value Register Low (PVAL5L) See <a href="#">page 174</a> .	Read:	Bit 7	6	5	4	3	2	1	Bit 0
		Write:								
		Reset:	0	0	0	0	0	0	0	0
\$0034	PWM 6 Value Register High (PVAL6H) See <a href="#">page 174</a> .	Read:	Bit 15	14	13	12	11	10	9	Bit 8
		Write:								
		Reset:	0	0	0	0	0	0	0	0
\$0035	PWM 6 Value Register Low (PVAL6L) See <a href="#">page 174</a> .	Read:	Bit 7	6	5	4	3	2	1	Bit 0
		Write:								
		Reset:	0	0	0	0	0	0	0	0
\$0036	Dead Time Write-Once Register (DEADTM) See <a href="#">page 179</a> .	Read:	Bit 7	6	5	4	3	2	1	Bit 0
		Write:								
		Reset:	1	1	1	1	1	1	1	1
\$0037	PWM Disable Mapping Write- Once Register (DISMAP) See <a href="#">page 180</a> .	Read:	Bit 7	6	5	4	3	2	1	Bit 0
		Write:								
		Reset:	1	1	1	1	1	1	1	1
\$0038	SCI Control Register 1 (SCC1) See <a href="#">page 301</a> .	Read:	LOOPS	ENSCI	TXINV	M	WAKE	ILTY	PEN	PTY
		Write:								
		Reset:	0	0	0	0	0	0	0	0
\$0039	SCI Control Register 2 (SCC2) See <a href="#">page 304</a> .	Read:	SCTIE	TCIE	SCRIE	ILIE	TE	RE	RWU	SBK
		Write:								
		Reset:	0	0	0	0	0	0	0	0
\$003A	SCI Control Register 3 (SCC3) See <a href="#">page 307</a> .	Read:	R8	T8	0	0	ORIE	NEIE	FEIE	PEIE
		Write:								
		Reset:	U	U	0	0	0	0	0	0
\$003B	SCI Status Register 1 (SCS1) See <a href="#">page 309</a> .	Read:	SCTE	TC	SCRf	IDLE	OR	NF	FE	PE
		Write:								
		Reset:	1	1	0	0	0	0	0	0

X = Indeterminate    U = Unaffected     = Unimplemented    R = Reserved

Figure 2-2. Control, Status, and Data Registers (Sheet 6 of 9)

# Memory Map

Addr.	Name	Bit 7	6	5	4	3	2	1	Bit 0	
\$003C	SCI Status Register 2 (SCS2) See <a href="#">page 313</a> .	Read:						BKF	RPF	
		Write:								
		Reset:	0	0	0	0	0	0	0	0
\$003D	SCI Data Register (SCDR) See <a href="#">page 314</a> .	Read:	Bit 7	6	5	4	3	2	1	Bit 0
		Write:								
		Reset:	Unaffected by reset							
\$003E	SCI Baud Rate Register (SCBR) See <a href="#">page 314</a> .	Read:			SCP1	SCP0	R	SCR2	SCR1	SCR0
		Write:								
		Reset:	0	0	0	0	0	0	0	0
\$003F	Timer B Status and Control Register (TBSC) See <a href="#">page 240</a> .	Read:	TOF	TOIE	TSTOP	0	0	PS2	PS1	PS0
		Write:	0			TRST				
		Reset:	0	0	1	0	0	0	0	0
\$0040	Timer B Counter Register High (TBCNTH) See <a href="#">page 242</a> .	Read:	Bit 15	14	13	12	11	10	9	Bit 8
		Write:								
		Reset:	0	0	0	0	0	0	0	0
\$0041	Timer B Counter Register Low (TBCNTL) See <a href="#">page 242</a> .	Read:	Bit 7	6	5	4	3	2	1	Bit 0
		Write:								
		Reset:	0	0	0	0	0	0	0	0
\$0042	Timer B Counter Modulo Register High (TBMODH) See <a href="#">page 243</a> .	Read:	Bit 15	14	13	12	11	10	9	Bit 8
		Write:								
		Reset:	1	1	1	1	1	1	1	1
\$0043	Timer B Counter Modulo Register Low (TBMODL) See <a href="#">page 243</a> .	Read:	Bit 7	6	5	4	3	2	1	Bit 0
		Write:								
		Reset:	1	1	1	1	1	1	1	1
\$0044	Timer B Channel 0 Status and Control Register (TBSC0) See <a href="#">page 244</a> .	Read:	CH0F	CH0IE	MS0B	MS0A	ELS0B	ELS0A	TOV0	CH0MAX
		Write:	0							
		Reset:	0	0	0	0	0	0	0	0
\$0045	Timer B Channel 0 Register High (TBCH0H) See <a href="#">page 248</a> .	Read:	Bit 15	14	13	12	11	10	9	Bit 8
		Write:								
		Reset:	Indeterminate after reset							

X = Indeterminate    U = Unaffected     = Unimplemented    R = Reserved

**Figure 2-2. Control, Status, and Data Registers (Sheet 7 of 9)**



Addr.	Name	Bit 7	6	5	4	3	2	1	Bit 0	
\$0046	Timer B Channel 0 Register Low (TBCH0L) See <a href="#">page 248</a> .	Read:	Bit 7	6	5	4	3	2	1	Bit 0
		Write:	Bit 7	6	5	4	3	2	1	Bit 0
		Reset:	Indeterminate after reset							
\$0047	Timer B Channel 1 Status and Control Register (TBSC1) See <a href="#">page 244</a> .	Read:	CH1F	CH1IE	0	MS1A	ELS1B	ELS1A	TOV1	CH1MAX
		Write:	0		MS1A	ELS1B	ELS1A	TOV1	CH1MAX	
		Reset:	0	0	0	0	0	0	0	0
\$0048	Timer B Channel 1 Register High (TBCH1H) See <a href="#">page 248</a> .	Read:	Bit 15	14	13	12	11	10	9	Bit 8
		Write:	Bit 15	14	13	12	11	10	9	Bit 8
		Reset:	Indeterminate after reset							
\$0049	Timer B Channel 1 Register Low (TBCH1L) See <a href="#">page 248</a> .	Read:	Bit 7	6	5	4	3	2	1	Bit 0
		Write:	Bit 7	6	5	4	3	2	1	Bit 0
		Reset:	Indeterminate after reset							
\$004A	Timer B Channel 2 Status and Control Register (TBSC2) See <a href="#">page 244</a> .	Read:	CH2F	CH2IE	MS2B	MS2A	ELS2B	ELS2A	TOV2	CH2MAX
		Write:	0		MS2B	MS2A	ELS2B	ELS2A	TOV2	CH2MAX
		Reset:	0	0	0	0	0	0	0	0
\$004B	Timer B Channel 2 Register High (TBCH2H) See <a href="#">page 248</a> .	Read:	Bit 15	14	13	12	11	10	9	Bit 8
		Write:	Bit 15	14	13	12	11	10	9	Bit 8
		Reset:	Indeterminate after reset							
\$004C	Timer B Channel 2 Register Low (TBCH2L) See <a href="#">page 248</a> .	Read:	Bit 7	6	5	4	3	2	1	Bit 0
		Write:	Bit 7	6	5	4	3	2	1	Bit 0
		Reset:	Indeterminate after reset							
\$004D	Timer B Channel 3 Status and Control Register (TBSC3) See <a href="#">page 244</a> .	Read:	CH3F	CH3IE	0	MS3A	ELS3B	ELS3A	TOV3	CH3MAX
		Write:	0		MS3A	ELS3B	ELS3A	TOV3	CH3MAX	
		Reset:	0	0	0	0	0	0	0	0
\$004E	Timer B Channel 3 Register High (TBCH3H) See <a href="#">page 248</a> .	Read:	Bit 15	14	13	12	11	10	9	Bit 8
		Write:	Bit 15	14	13	12	11	10	9	Bit 8
		Reset:	Indeterminate after reset							
\$004F	Timer B Channel 3 Register Low (TBCH3L) See <a href="#">page 248</a> .	Read:	Bit 7	6	5	4	3	2	1	Bit 0
		Write:	Bit 7	6	5	4	3	2	1	Bit 0
		Reset:	Indeterminate after reset							

X = Indeterminate    U = Unaffected     = Unimplemented    R = Reserved

**Figure 2-2. Control, Status, and Data Registers (Sheet 8 of 9)**

# Memory Map

Addr.	Name	Bit 7	6	5	4	3	2	1	Bit 0	
\$FE00	SIM Break Status Register (SBSR) See <a href="#">page 99</a> .	Read:	R	R	R	R	R	SBSW	R	
		Write:						Note		
Note: Writing a logic 0 clears SBSW.		Reset:	0							
\$FE01	SIM Reset Status Register (SRSR) See <a href="#">page 101</a> .	Read:	POR	PIN	COP	ILOP	ILAD	0	LVI	0
		Write:								
		Reset:	1	0	0	0	0	0	0	
\$FE03	SIM Break Flag Control Register (SBFCR) See <a href="#">page 102</a> .	Read:	BCFE	R	R	R	R	R	R	
		Write:								
		Reset:	0							
\$FE07	EPROM Control Register (EPMCR) See <a href="#">page 56</a> .	Read:	0	0	0	0	0	ELAT	0	EPGM
		Write:								
		Reset:	0	0	0	0	0	0	0	
\$FE0B	PLL Control Register (PCTL) See <a href="#">page 117</a> .	Read:	PLLIE	PLLF	PLLON	BCS	1	1	1	1
		Write:								
		Reset:	0	0	1	0	1	1	1	1
\$FE0C	PLL Bandwidth Control Register (PBWC) See <a href="#">page 119</a> .	Read:	AUTO	LOCK	ACQ	XLD	0	0	0	0
		Write:								
		Reset:	0	0	0	0	0	0	0	0
\$FE0D	PLL Programming Register (PPG) See <a href="#">page 121</a> .	Read:	MUL7	MUL6	MUL5	MUL4	VRS7	VRS6	VRS5	VRS4
		Write:								
		Reset:	0	1	1	0	0	1	1	0
\$FE0F	LVI Status Register (LVISR) See <a href="#">page 350</a> .	Read:	LVIOUT	0	0	0	0	0	0	0
		Write:								
		Reset:	0	0	0	0	0	0	0	0
\$FFFF	COP Control Register (COPCTL) See <a href="#">page 336</a> .	Read:	Low byte of reset vector							
		Write:	Writing to \$FFFF clears COP counter							
		Reset:	Unaffected by reset							

X = Indeterminate    U = Unaffected     = Unimplemented    R = Reserved

**Figure 2-2. Control, Status, and Data Registers (Sheet 9 of 9)**

**Table 2-1** is a list of vector locations.

**Table 2-1. Vector Addresses**

Address	Vector
\$FFD2	SCI Transmit Vector (High)
\$FFD3	SCI Transmit Vector (Low)
\$FFD4	SCI Receive Vector (High)
\$FFD5	SCI Receive Vector (Low)
\$FFD6	SCI Error Vector (High)
\$FFD7	SCI Error Vector (Low)
\$FFD8	SPI Transmit Vector (High)
\$FFD9	SPI Transmit Vector (Low)
\$FFDA	SPI Receive Vector (High)
\$FFDB	SPI Receive Vector (Low)
\$FFDC	A/D Vector (High)
\$FFDD	A/D Vector (Low)
\$FFDE	TIM A Overflow Vector (High)
\$FFDF	TIM A Overflow Vector (Low)
\$FFE0	TIM A Channel 1 Vector (High)
\$FFE1	TIM A Channel 1 Vector (Low)
\$FFE2	TIM A Channel 0 Vector (High)
\$FFE3	TIM A Channel 0 Vector (Low)
\$FFE4	TIM B Overflow Vector (High)
\$FFE5	TIM B Overflow Vector (Low)
\$FFE6	TIM B Channel 3 Vector (High)
\$FFE7	TIM B Channel 3 Vector (Low)
\$FFE8	TIM B Channel 2 Vector (High)
\$FFE9	TIM B Channel 2 Vector (Low)
\$FFEA	TIM B Channel 1 Vector (High)
\$FFEB	TIM B Channel 1 Vector (Low)
\$FFEC	TIM B Channel 0 Vector (High)
\$FFED	TIM B Channel 0 Vector (Low)
\$FFEE	PWM Vector (High)
\$FFEF	PWM Vector (Low)

Low

Priority

**Table 2-1. Vector Addresses (Continued)**

Address	Vector
\$FFF0	FAULT 4 (High)
\$FFF1	FAULT 4 (Low)
\$FFF2	FAULT 3 (High)
\$FFF3	FAULT 3 (Low)
\$FFF4	FAULT 2 (High)
\$FFF5	FAULT 2 (Low)
\$FFF6	FAULT 1 (High)
\$FFF7	FAULT 1 (Low)
\$FFF8	PLL Vector (High)
\$FFF9	PLL Vector (Low)
\$FFFA	IRQ1 Vector (High)
\$FFFFB	IRQ1 Vector (Low)
\$FFFC	SWI Vector (High)
\$FFFD	SWI Vector (Low)
\$FFFE	Reset Vector (High)
\$FFFF	Reset Vector (Low)

## 2.4 Monitor ROM

The 240 bytes at addresses \$FE10–\$FEFF are reserved ROM addresses that contain the instructions for the monitor functions. (See [Section 10. Monitor ROM \(MON\)](#).)

## Section 3. Random-Access Memory (RAM)

### 3.1 Contents

3.2	Introduction . . . . .	53
3.3	Functional Description . . . . .	53

### 3.2 Introduction

This section describes the 512 bytes of RAM.

### 3.3 Functional Description

Addresses \$0050–\$024F are RAM locations. The location of the stack RAM is programmable. The 16-bit stack pointer allows the stack to be anywhere in the 64-Kbyte memory space.

**NOTE:** *For correct operation, the stack pointer must point only to RAM locations.*

Within page zero are 160 bytes of RAM. Because the location of the stack RAM is programmable, all page zero RAM locations can be used for I/O control and user data or code. When the stack pointer is moved from its reset location at \$00FF, direct addressing mode instructions can access efficiently all page zero RAM locations. Page zero RAM, therefore, provides ideal locations for frequently accessed global variables.

Before processing an interrupt, the CPU uses five bytes of the stack to save the contents of the CPU registers.

**NOTE:** *For M6805 compatibility, the H register is not stacked.*

## Random-Access Memory (RAM)

During a subroutine call, the CPU uses two bytes of the stack to store the return address. The stack pointer decrements during pushes and increments during pulls.

**NOTE:** *Be careful when using nested subroutines. The CPU may overwrite data in the RAM during a subroutine or during the interrupt stacking operation.*

## Section 4. EPROM/OTPROM

### 4.1 Contents

4.2	Introduction . . . . .	55
4.3	Functional Description . . . . .	55
4.4	EPROM/OTPROM Control Register . . . . .	56
4.5	EPROM/OTPROM Programming Sequence . . . . .	57

### 4.2 Introduction

This section describes the non-volatile memory (EPROM/OTPROM).

### 4.3 Functional Description

An MCU with a quartz window has 16 Kbytes of erasable, programmable ROM (EPROM). The quartz window allows EPROM erasure by using ultraviolet light. In an MCU without the quartz window, the EPROM cannot be erased and serves as 16 Kbytes of one-time programmable ROM (OTPROM). An unprogrammed or erased location reads as \$00. The following addresses are user EPROM/OTPROM locations:

- \$BE00–\$FDFF
- \$FFD2–\$FFFF (These locations are reserved for user-defined interrupt and reset vectors.)

Programming tools are available from Freescale. Contact your local Freescale representative for more information.

**NOTE:** *A security feature prevents viewing of the EPROM/OTPROM contents.*<sup>1</sup>

---


1. No security feature is absolutely secure. However, Freescale's strategy is to make reading or copying the EPROM/OTPROM difficult for unauthorized users.

## 4.4 EPROM/OTPROM Control Register

The EPROM control register controls EPROM/OTPROM programming.

Address: \$FE07

\$FE07	Bit 7	6	5	4	3	2	1	Bit 0
Read:	0	0	0	0	0	ELAT	0	EPGM
Write:								
Reset:	0	0	0	0	0	0	0	0

 = Unimplemented

**Figure 4-1. EPROM/OTPROM Control Register (EPMCR)**

### ELAT — EPROM/OTPROM Latch Control Bit

This read/write bit latches the address and data buses for programming the EPROM/OTPROM. Clearing ELAT also clears the EPGM bit. EPROM/OTPROM data cannot be read when ELAT is set.

- 1 = Buses configured for EPROM/OTPROM programming
- 0 = Buses configured for normal operation

### EPGM — EPROM/OTPROM Program Control Bit

This read/write bit applies the programming voltage from the  $\overline{\text{IRQ1}}/V_{PP}$  pin to the EPROM/OTPROM. To write to the EPGM bit, the ELAT bit must be set already. Reset clears the EPGM bit.

- 1 = EPROM/OTPROM programming power switched on
- 0 = EPROM/OTPROM programming power switched off



## 4.5 EPROM/OTPROM Programming Sequence

The unprogrammed state is a 0. Programming changes the state to a 1.

Use the following procedure to program a byte of EPROM/OTPROM:

1. Apply  $V_{DD} + V_{HI}$  to the  $\overline{IRQ1}/V_{PP}$  pin.
2. Set the ELAT bit.

**NOTE:** *Writing logic 1s to both the ELAT and EPGM bits with a single instruction sets only the ELAT bit. EPGM must be set by a separate instruction in the programming sequence.*

3. Write to any user EPROM/OTPROM address.

**NOTE:** *Writing to an invalid address prevents the programming voltage from being applied.*

4. Set the EPGM bit.
5. Wait for a time,  $t_{EPGM}$ .
6. Clear the ELAT and EPGM bits.

Setting the ELAT bit configures the address and data buses to latch data for programming the array. Only data written to a valid EPROM address will be latched. Attempts to read any other valid EPROM address after step 2 will read the latched data written in step 3. Further writes to valid EPROM addresses after the first write (step 3) are ignored.

The EPGM bit cannot be set if ELAT bit is cleared. This is to ensure proper programming sequence. If EPGM is set and a valid EPROM write occurred,  $V_{PP}$  will be applied to the user EPROM array. When the EPGM bit is cleared, the program voltage is removed from the array.



## Section 5. Configuration Register (CONFIG)

### 5.1 Contents

5.2	Introduction . . . . .	59
5.3	Functional Description . . . . .	60

### 5.2 Introduction

This section describes the configuration register (CONFIG). This register contains bits that configure the following options:

- Resets caused by the LVI module
- Power to the LVI module
- Computer operating properly module (COP)
- Top-side PWM polarity
- Bottom-side PWM polarity
- Edge-aligned versus center-aligned PWMs
- Six independent PWMs versus three complementary PWM pairs

## 5.3 Functional Description

The configuration register is a write-once register. Out of reset, the configuration register will read all 0s. Once the register is written, further writes will have no effect until a reset occurs.

**NOTE:** *If the LVI module and the LVI reset signal are enabled, a reset occurs when  $V_{DD}$  falls to a voltage,  $LVI_{TRIPF}$ , and remains at or below that level for at least nine consecutive CPU cycles. Once an LVI reset occurs, the MCU remains in reset until  $V_{DD}$  rises to a voltage,  $LVI_{TRIPR}$ .*

\$001F	Bit 7	6	5	4	3	2	1	Bit 0
Read:	EDGE	BOTNEG	TOPNEG	INDEP	LVIRST	LVIPWR	Bit 1	COPD
Write:								
Reset:	0	0	0	0	0	0	0	0

**Figure 5-1. Configuration Register (CONFIG)**

**EDGE** — Edge-Align Enable Bit

EDGE determines if the motor control PWM will operate in edge-aligned mode or center-aligned mode. (See [Section 9. Pulse Width Modulator for Motor Control \(PWMMC\)](#).)

1 = Edge-aligned mode enabled

0 = Center-aligned mode enabled

**BOTNEG** — Bottom-Side PWM Polarity Bit

BOTNEG determines if the bottom-side PWMs will have positive or negative polarity. (See [Section 9. Pulse Width Modulator for Motor Control \(PWMMC\)](#).)

1 = Negative polarity

0 = Positive polarity

**TOPNEG** — Top-Side PWM Polarity Bit

TOPNEG determines if the top-side PWMs will have positive or negative polarity. (See [Section 9. Pulse Width Modulator for Motor Control \(PWMMC\)](#).)

1 = Negative polarity

0 = Positive polarity

**INDEP** — Independent Mode Enable Bit

INDEP determines if the motor control PWMs will be six independent PWMs or three complementary PWM pairs. (See [Section 9. Pulse Width Modulator for Motor Control \(PWMMC\)](#).)

- 1 = Six independent PWMs
- 0 = Three complementary PWM pairs

**LVIPWR** — LVI Power Disable Bit

LVIPWR disables the LVI module. (See [Section 18. Low-Voltage Inhibit \(LVI\)](#).)

- 1 = LVI module power disabled
- 0 = LVI module power enabled

**LVIRST** — LVI Reset Disable Bit

LVIRST disables the reset signal from the LVI module. (See [Section 18. Low-Voltage Inhibit \(LVI\)](#).)

- 1 = LVI module resets disabled
- 0 = LVI module resets enabled

**COPD** — COP Disable Bit

COPD disables the COP module. (See [Section 16. Computer Operating Properly \(COP\)](#).)

- 1 = COP module disabled
- 0 = COP module enabled

## Configuration Register (CONFIG)

## Section 6. Central Processor Unit (CPU)

### 6.1 Contents

6.2	Introduction . . . . .	63
6.3	Features . . . . .	64
6.4	CPU Registers . . . . .	64
6.4.1	Accumulator (A) . . . . .	65
6.4.2	Index Register (H:X) . . . . .	66
6.4.3	Stack Pointer (SP) . . . . .	67
6.4.4	Program Counter (PC) . . . . .	68
6.4.5	Condition Code Register (CCR) . . . . .	69
6.5	Arithmetic/Logic Unit (ALU) . . . . .	71
6.6	Instruction Set Summary . . . . .	72
6.7	Opcode Map . . . . .	79

### 6.2 Introduction

This section describes the central processor unit (CPU08, Version A). The M68HC08 CPU is an enhanced and fully object-code-compatible version of the M68HC05 CPU. The *CPU08 Reference Manual* (Freescale document number CPU08RM/AD) contains a description of the CPU instruction set, addressing modes, and architecture.

## 6.3 Features

Features of the CPU include the following:

- Full upward, object-code compatibility with M68HC05 Family
- 16-bit stack pointer with stack manipulation instructions
- 16-bit index register with X-register manipulation instructions
- 8-MHz CPU internal bus frequency
- 64-Kbyte program/data memory space
- 16 addressing modes
- Memory-to-memory data moves without using accumulator
- Fast 8-bit by 8-bit multiply and 16-bit by 8-bit divide instructions
- Enhanced binary-coded decimal (BCD) data handling
- Modular architecture with expandable internal bus definition for extension of addressing range beyond 64 Kbytes
- Low-power wait mode

## 6.4 CPU Registers

**Figure 6-1** shows the five CPU registers. CPU registers are not part of the memory map.



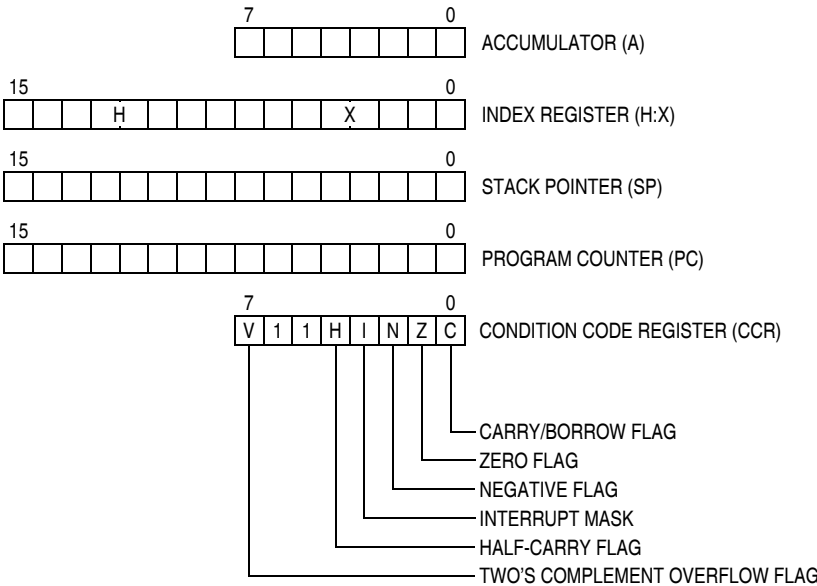


Figure 6-1. CPU Registers

6.4.1 Accumulator (A)

The accumulator is a general-purpose 8-bit register. The CPU uses the accumulator to hold operands and the results of arithmetic/logic operations.

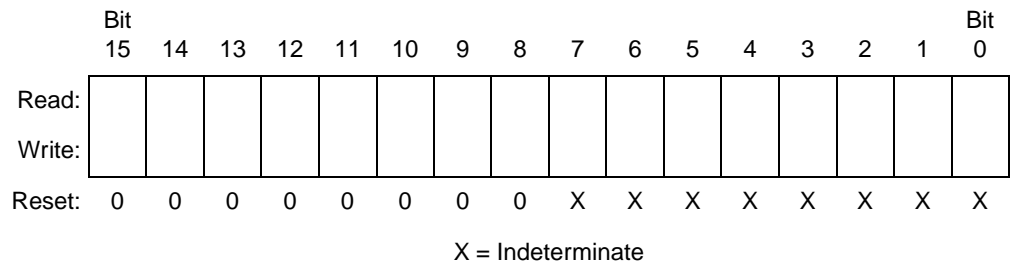


Figure 6-2. Accumulator (A)

## 6.4.2 Index Register (H:X)

The 16-bit index register allows indexed addressing of a 64-Kbyte memory space. H is the upper byte of the index register, and X is the lower byte. H:X is the concatenated 16-bit index register.

In the indexed addressing modes, the CPU uses the contents of the index register to determine the conditional address of the operand.



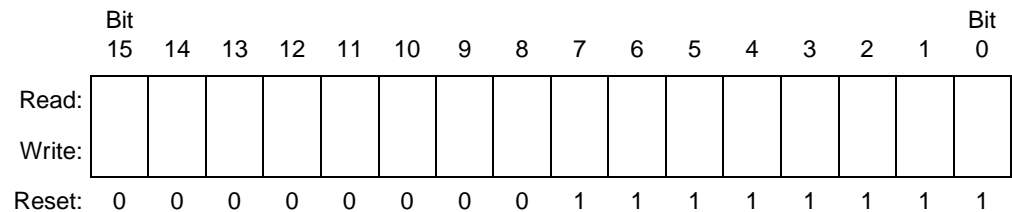
**Figure 6-3. Index Register (H:X)**

The index register can serve also as a temporary data storage location.

### 6.4.3 Stack Pointer (SP)

The stack pointer is a 16-bit register that contains the address of the next location on the stack. During a reset, the stack pointer is preset to \$00FF. The reset stack pointer (RSP) instruction sets the least significant byte to \$FF and does not affect the most significant byte. The stack pointer decrements as data is pushed onto the stack and increments as data is pulled from the stack.

In the stack pointer 8-bit offset and 16-bit offset addressing modes, the stack pointer can function as an index register to access data on the stack. The CPU uses the contents of the stack pointer to determine the conditional address of the operand.



**Figure 6-4. Stack Pointer (SP)**

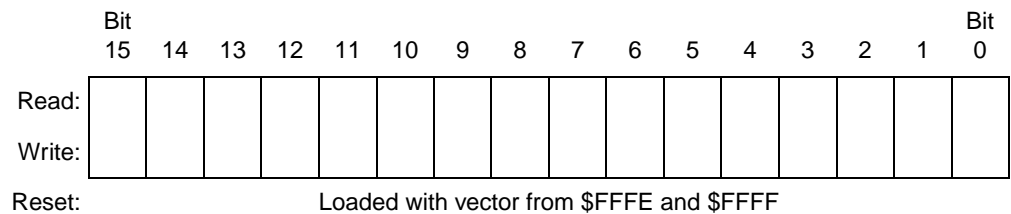
**NOTE:** *The location of the stack is arbitrary and may be relocated anywhere in RAM. Moving the SP out of page zero (\$0000 to \$00FF) frees direct address (page zero) space. For correct operation, the stack pointer must point only to RAM locations.*

## 6.4.4 Program Counter (PC)

The program counter is a 16-bit register that contains the address of the next instruction or operand to be fetched.

Normally, the program counter automatically increments to the next sequential memory location every time an instruction or operand is fetched. Jump, branch, and interrupt operations load the program counter with an address other than that of the next sequential location.

During reset, the program counter is loaded with the reset vector address located at \$FFFE and \$FFFF. The vector address is the address of the first instruction to be executed after exiting the reset state.



**Figure 6-5. Program Counter (PC)**

### 6.4.5 Condition Code Register (CCR)

The 8-bit condition code register contains the interrupt mask and five flags that indicate the results of the instruction just executed. Bits 6 and 5 are set permanently to logic one. The following paragraphs describe the functions of the condition code register.

	Bit 7	6	5	4	3	2	1	Bit 0
Read:	V	1	1	H	I	N	Z	C
Write:								
Reset:	X	1	1	X	1	X	X	X

X = Indeterminate

**Figure 6-6. Condition Code Register (CCR)**

#### V — Overflow Flag

The CPU sets the overflow flag when a two's complement overflow occurs. The signed branch instructions BGT, BGE, BLE, and BLT use the overflow flag.

1 = Overflow

0 = No overflow

#### H — Half-Carry Flag

The CPU sets the half-carry flag when a carry occurs between accumulator bits 3 and 4 during an ADD or ADC operation. The half-carry flag is required for binary-coded decimal (BCD) arithmetic operations. The DAA instruction uses the states of the H and C flags to determine the appropriate correction factor.

1 = Carry between bits 3 and 4

0 = No carry between bits 3 and 4

### I — Interrupt Mask

When the interrupt mask is set, all maskable CPU interrupts are disabled. CPU interrupts are enabled when the interrupt mask is cleared. When a CPU interrupt occurs, the interrupt mask is set automatically after the CPU registers are saved on the stack, but before the interrupt vector is fetched.

1 = Interrupts disabled

0 = Interrupts enabled

**NOTE:** *To maintain M6805 compatibility, the upper byte of the index register (H) is not stacked automatically. If the interrupt service routine modifies H, then the user must stack and unstack H using the PSHH and PULH instructions.*

After the I bit is cleared, the highest-priority interrupt request is serviced first.

A return from interrupt (RTI) instruction pulls the CPU registers from the stack and restores the interrupt mask from the stack. After any reset, the interrupt mask is set and can only be cleared by the clear interrupt mask software instruction (CLI).

### N — Negative Flag

The CPU sets the negative flag when an arithmetic operation, logic operation, or data manipulation produces a negative result, setting bit 7 of the result.

1 = Negative result

0 = Non-negative result

### Z — Zero Flag

The CPU sets the zero flag when an arithmetic operation, logic operation, or data manipulation produces a result of \$00.

1 = Zero result

0 = Non-zero result

**C — Carry/Borrow Flag**

The CPU sets the carry/borrow flag when an addition operation produces a carry out of bit 7 of the accumulator or when a subtraction operation requires a borrow. Some instructions — such as bit test and branch, shift, and rotate — also clear or set the carry/borrow flag.

1 = Carry out of bit 7

0 = No carry out of bit 7

**6.5 Arithmetic/Logic Unit (ALU)**

The ALU performs the arithmetic and logic operations defined by the instruction set.

Refer to the *CPU08 Reference Manual* (Freescale document number CPU08RM/AD) for a description of the instructions and addressing modes and more detail about CPU architecture.

## 6.6 Instruction Set Summary

Table 6-1 provides a summary of the M68HC08 instruction set.

Table 6-1. Instruction Set Summary

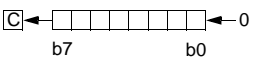
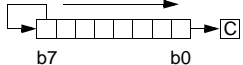
Source Form	Operation	Description	Effect on CCR						Address Mode	Opcode	Operand	Cycles
			V	H	I	N	Z	C				
ADC #opr ADC opr ADC opr,X ADC opr,X ADC ,X ADC opr,SP ADC opr,SP	Add with Carry	$A \leftarrow (A) + (M) + (C)$	↑	↑	-	↑	↑	↑	IMM DIR EXT IX2 IX1 IX SP1 SP2	A9 B9 C9 D9 E9 F9 9EE9 9ED9	ii dd hh ll ee ff ff F9 ff ee ff	2 3 4 4 3 2 4 5
ADD #opr ADD opr ADD opr ADD opr,X ADD opr,X ADD ,X ADD opr,SP ADD opr,SP	Add without Carry	$A \leftarrow (A) + (M)$	↑	↑	-	↑	↑	↑	IMM DIR EXT IX2 IX1 IX SP1 SP2	AB BB CB DB EB FB 9EEB 9EDB	ii dd hh ll ee ff ff FB ff ee ff	2 3 4 4 3 2 4 5
AIS #opr	Add Immediate Value (Signed) to SP	$SP \leftarrow (SP) + (16 \ll M)$	-	-	-	-	-	-	IMM	A7	ii	2
AIX #opr	Add Immediate Value (Signed) to H:X	$H:X \leftarrow (H:X) + (16 \ll M)$	-	-	-	-	-	-	IMM	AF	ii	2
AND #opr AND opr AND opr AND opr,X AND opr,X AND ,X AND opr,SP AND opr,SP	Logical AND	$A \leftarrow (A) \& (M)$	0	-	-	↑	↑	-	IMM DIR EXT IX2 IX1 IX SP1 SP2	A4 B4 C4 D4 E4 F4 9EE4 9ED4	ii dd hh ll ee ff ff F4 ff ee ff	2 3 4 4 3 2 4 5
ASL opr ASLA ASLX ASL opr,X ASL ,X ASL opr,SP	Arithmetic Shift Left (Same as LSL)		↑	-	-	↑	↑	↑	DIR INH INH IX1 IX SP1	38 48 58 68 78 9E68	dd ff ff	4 1 1 4 3 5
ASR opr ASRA ASRX ASR opr,X ASR opr,X ASR opr,SP	Arithmetic Shift Right		↑	-	-	↑	↑	↑	DIR INH INH IX1 IX SP1	37 47 57 67 77 9E67	dd ff ff	4 1 1 4 3 5
BCC rel	Branch if Carry Bit Clear	$PC \leftarrow (PC) + 2 + rel ? (C) = 0$	-	-	-	-	-	-	REL	24	rr	3



Table 6-1. Instruction Set Summary (Continued)

Source Form	Operation	Description	Effect on CCR						Address Mode	Opcode	Operand	Cycles
			V	H	I	N	Z	C				
BCLR <i>n, opr</i>	Clear Bit <i>n</i> in <i>M</i>	$M_n \leftarrow 0$	-	-	-	-	-	-	DIR (b0) DIR (b1) DIR (b2) DIR (b3) DIR (b4) DIR (b5) DIR (b6) DIR (b7)	11 13 15 17 19 1B 1D 1F	dd dd dd dd dd dd dd dd	4 4 4 4 4 4 4 4
BCS <i>rel</i>	Branch if Carry Bit Set (Same as BLO)	$PC \leftarrow (PC) + 2 + rel ? (C) = 1$	-	-	-	-	-	-	REL	25	rr	3
BEQ <i>rel</i>	Branch if Equal	$PC \leftarrow (PC) + 2 + rel ? (Z) = 1$	-	-	-	-	-	-	REL	27	rr	3
BGE <i>opr</i>	Branch if Greater Than or Equal To (Signed Operands)	$PC \leftarrow (PC) + 2 + rel ? (N \oplus V) = 0$	-	-	-	-	-	-	REL	90	rr	3
BGT <i>opr</i>	Branch if Greater Than (Signed Operands)	$PC \leftarrow (PC) + 2 + rel ? (Z)   (N \oplus V) = 0$	-	-	-	-	-	-	REL	92	rr	3
BHCC <i>rel</i>	Branch if Half Carry Bit Clear	$PC \leftarrow (PC) + 2 + rel ? (H) = 0$	-	-	-	-	-	-	REL	28	rr	3
BHCS <i>rel</i>	Branch if Half Carry Bit Set	$PC \leftarrow (PC) + 2 + rel ? (H) = 1$	-	-	-	-	-	-	REL	29	rr	3
BHI <i>rel</i>	Branch if Higher	$PC \leftarrow (PC) + 2 + rel ? (C)   (Z) = 0$	-	-	-	-	-	-	REL	22	rr	3
BHS <i>rel</i>	Branch if Higher or Same (Same as BCC)	$PC \leftarrow (PC) + 2 + rel ? (C) = 0$	-	-	-	-	-	-	REL	24	rr	3
BIH <i>rel</i>	Branch if $\overline{IRQ}$ Pin High	$PC \leftarrow (PC) + 2 + rel ? \overline{IRQ} = 1$	-	-	-	-	-	-	REL	2F	rr	3
BIL <i>rel</i>	Branch if $\overline{IRQ}$ Pin Low	$PC \leftarrow (PC) + 2 + rel ? \overline{IRQ} = 0$	-	-	-	-	-	-	REL	2E	rr	3
BIT # <i>opr</i> BIT <i>opr</i> BIT <i>opr</i> BIT <i>opr,X</i> BIT <i>opr,X</i> BIT <i>X</i> BIT <i>opr,SP</i> BIT <i>opr,SP</i>	Bit Test	(A) & (M)	0	-	-	↑	↑	-	IMM DIR EXT IX2 IX1 IX SP1 SP2	A5 B5 C5 D5 E5 F5 9EE5 9ED5	ii dd hh ll ee ff ff ff ff ee ff	2 3 4 4 3 2 4 5
BLE <i>opr</i>	Branch if Less Than or Equal To (Signed Operands)	$PC \leftarrow (PC) + 2 + rel ? (Z)   (N \oplus V) = 1$	-	-	-	-	-	-	REL	93	rr	3
BLO <i>rel</i>	Branch if Lower (Same as BCS)	$PC \leftarrow (PC) + 2 + rel ? (C) = 1$	-	-	-	-	-	-	REL	25	rr	3
BLS <i>rel</i>	Branch if Lower or Same	$PC \leftarrow (PC) + 2 + rel ? (C)   (Z) = 1$	-	-	-	-	-	-	REL	23	rr	3
BLT <i>opr</i>	Branch if Less Than (Signed Operands)	$PC \leftarrow (PC) + 2 + rel ? (N \oplus V) = 1$	-	-	-	-	-	-	REL	91	rr	3
BMC <i>rel</i>	Branch if Interrupt Mask Clear	$PC \leftarrow (PC) + 2 + rel ? (I) = 0$	-	-	-	-	-	-	REL	2C	rr	3
BMI <i>rel</i>	Branch if Minus	$PC \leftarrow (PC) + 2 + rel ? (N) = 1$	-	-	-	-	-	-	REL	2B	rr	3
BMS <i>rel</i>	Branch if Interrupt Mask Set	$PC \leftarrow (PC) + 2 + rel ? (I) = 1$	-	-	-	-	-	-	REL	2D	rr	3

## Table 6-1. Instruction Set Summary (Continued)

Source Form	Operation	Description	Effect on CCR						Address Mode	Opcode	Operand	Cycles
			V	H	I	N	Z	C				
BNE <i>rel</i>	Branch if Not Equal	$PC \leftarrow (PC) + 2 + rel ? (Z) = 0$	-	-	-	-	-	-	REL	26	rr	3
BPL <i>rel</i>	Branch if Plus	$PC \leftarrow (PC) + 2 + rel ? (N) = 0$	-	-	-	-	-	-	REL	2A	rr	3
BRA <i>rel</i>	Branch Always	$PC \leftarrow (PC) + 2 + rel$	-	-	-	-	-	-	REL	20	rr	3
BRCLR <i>n,opr,rel</i>	Branch if Bit <i>n</i> in M Clear	$PC \leftarrow (PC) + 3 + rel ? (Mn) = 0$	-	-	-	-	-	↓	DIR (b0) DIR (b1) DIR (b2) DIR (b3) DIR (b4) DIR (b5) DIR (b6) DIR (b7)	01 03 05 07 09 0B 0D 0F	dd rr dd rr dd rr dd rr dd rr dd rr dd rr dd rr	5 5 5 5 5 5 5 5
BRN <i>rel</i>	Branch Never	$PC \leftarrow (PC) + 2$	-	-	-	-	-	-	REL	21	rr	3
BRSET <i>n,opr,rel</i>	Branch if Bit <i>n</i> in M Set	$PC \leftarrow (PC) + 3 + rel ? (Mn) = 1$	-	-	-	-	-	↓	DIR (b0) DIR (b1) DIR (b2) DIR (b3) DIR (b4) DIR (b5) DIR (b6) DIR (b7)	00 02 04 06 08 0A 0C 0E	dd rr dd rr dd rr dd rr dd rr dd rr dd rr dd rr	5 5 5 5 5 5 5 5
BSET <i>n,opr</i>	Set Bit <i>n</i> in M	$Mn \leftarrow 1$	-	-	-	-	-	-	DIR (b0) DIR (b1) DIR (b2) DIR (b3) DIR (b4) DIR (b5) DIR (b6) DIR (b7)	10 12 14 16 18 1A 1C 1E	dd dd dd dd dd dd dd dd	4 4 4 4 4 4 4 4
BSR <i>rel</i>	Branch to Subroutine	$PC \leftarrow (PC) + 2$ ; push (PCL) $SP \leftarrow (SP) - 1$ ; push (PCH) $SP \leftarrow (SP) - 1$ $PC \leftarrow (PC) + rel$	-	-	-	-	-	-	REL	AD	rr	4
CBEQ <i>opr,rel</i> CBEQA # <i>opr,rel</i> CBEQX # <i>opr,rel</i> CBEQ <i>opr,X+,rel</i> CBEQ <i>X+,rel</i> CBEQ <i>opr,SP,rel</i>	Compare and Branch if Equal	$PC \leftarrow (PC) + 3 + rel ? (A) - (M) = \$00$ $PC \leftarrow (PC) + 3 + rel ? (A) - (M) = \$00$ $PC \leftarrow (PC) + 3 + rel ? (X) - (M) = \$00$ $PC \leftarrow (PC) + 3 + rel ? (A) - (M) = \$00$ $PC \leftarrow (PC) + 2 + rel ? (A) - (M) = \$00$ $PC \leftarrow (PC) + 4 + rel ? (A) - (M) = \$00$	-	-	-	-	-	-	DIR IMM IMM IX1+ IX+ SP1	31 41 51 61 71 9E61	dd rr ii rr ii rr ff rr rr ff rr	5 4 4 5 4 6
CLC	Clear Carry Bit	$C \leftarrow 0$	-	-	-	-	-	0	INH	98		1
CLI	Clear Interrupt Mask	$I \leftarrow 0$	-	-	0	-	-	-	INH	9A		2
CLR <i>opr</i> CLRA CLR X CLR H CLR <i>opr,X</i> CLR ,X CLR <i>opr,SP</i>	Clear	$M \leftarrow \$00$ $A \leftarrow \$00$ $X \leftarrow \$00$ $H \leftarrow \$00$ $M \leftarrow \$00$ $M \leftarrow \$00$ $M \leftarrow \$00$	0	-	-	0	1	-	DIR INH INH INH IX1 IX SP1	3F 4F 5F 8C 6F 7F 9E6F	dd    ff ff	3 1 1 1 3 2 4

**Table 6-1. Instruction Set Summary (Continued)**

Source Form	Operation	Description	Effect on CCR						Address Mode	Opcode	Operand	Cycles
			V	H	I	N	Z	C				
CMP #opr CMP opr CMP opr CMP opr,X CMP opr,X CMP ,X CMP opr,SP CMP opr,SP	Compare A with M	(A) – (M)	↓	–	–	↓	↓	↓	IMM DIR EXT IX2 IX1 IX SP1 SP2	A1 B1 C1 D1 E1 F1 9EE1 9ED1	ii dd hh ll ee ff ff ff ff ee ff	2 3 4 4 3 2 4 5
COM opr COMA COMX COM opr,X COM ,X COM opr,SP	Complement (One's Complement)	$M \leftarrow (\overline{M}) = \$FF - (M)$ $A \leftarrow (\overline{A}) = \$FF - (M)$ $X \leftarrow (\overline{X}) = \$FF - (M)$ $M \leftarrow (\overline{M}) = \$FF - (M)$ $M \leftarrow (\overline{M}) = \$FF - (M)$ $M \leftarrow (\overline{M}) = \$FF - (M)$	0	–	–	↓	↓	1	DIR INH INH IX1 IX SP1	33 43 53 63 73 9E63	dd ff ff ff	4 1 1 4 3 5
CPHX #opr CPHX opr	Compare H:X with M	(H:X) – (M:M + 1)	↓	–	–	↓	↓	↓	IMM DIR	65 75	ii ii+1 dd	3 4
CPX #opr CPX opr CPX opr CPX ,X CPX opr,X CPX opr,X CPX opr,SP CPX opr,SP	Compare X with M	(X) – (M)	↓	–	–	↓	↓	↓	IMM DIR EXT IX2 IX1 IX SP1 SP2	A3 B3 C3 D3 E3 F3 9EE3 9ED3	ii dd hh ll ee ff ff ff ff ee ff	2 3 4 4 3 2 4 5
DAA	Decimal Adjust A	(A) <sub>10</sub>	U	–	–	↓	↓	↓	INH	72		2
DBNZ opr,rel DBNZA rel DBNZX rel DBNZ opr,X,rel DBNZ X,rel DBNZ opr,SP,rel	Decrement and Branch if Not Zero	$A \leftarrow (A) - 1$ or $M \leftarrow (M) - 1$ or $X \leftarrow (X) - 1$ $PC \leftarrow (PC) + 3 + rel ? (result) \neq 0$ $PC \leftarrow (PC) + 2 + rel ? (result) \neq 0$ $PC \leftarrow (PC) + 2 + rel ? (result) \neq 0$ $PC \leftarrow (PC) + 3 + rel ? (result) \neq 0$ $PC \leftarrow (PC) + 2 + rel ? (result) \neq 0$ $PC \leftarrow (PC) + 4 + rel ? (result) \neq 0$	–	–	–	–	–	–	DIR INH INH IX1 IX SP1	3B 4B 5B 6B 7B 9E6B	dd rr rr rr ff rr rr ff rr	5 3 3 5 4 6
DEC opr DECA DECX DEC opr,X DEC ,X DEC opr,SP	Decrement	$M \leftarrow (M) - 1$ $A \leftarrow (A) - 1$ $X \leftarrow (X) - 1$ $M \leftarrow (M) - 1$ $M \leftarrow (M) - 1$ $M \leftarrow (M) - 1$	↓	–	–	↓	↓	–	DIR INH INH IX1 IX SP1	3A 4A 5A 6A 7A 9E6A	dd ff ff	4 1 1 4 3 5
DIV	Divide	$A \leftarrow (H:A)/(X)$ H ← Remainder	–	–	–	–	↓	↓	INH	52		7
EOR #opr EOR opr EOR opr EOR opr,X EOR opr,X EOR ,X EOR opr,SP EOR opr,SP	Exclusive OR M with A	$A \leftarrow (A \oplus M)$	0	–	–	↓	↓	–	IMM DIR EXT IX2 IX1 IX SP1 SP2	A8 B8 C8 D8 E8 F8 9EE8 9ED8	ii dd hh ll ee ff ff ff ff ee ff	2 3 4 4 4 3 2 4 5

## Table 6-1. Instruction Set Summary (Continued)

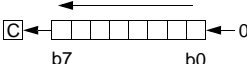
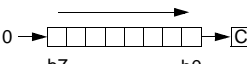
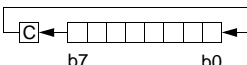
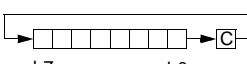
Source Form	Operation	Description	Effect on CCR					Address Mode	Opcode	Operand	Cycles	
			V	H	I	N	Z					C
INC <i>opr</i> INCA INCX INC <i>opr</i> ,X INC ,X INC <i>opr</i> ,SP	Increment	M ← (M) + 1 A ← (A) + 1 X ← (X) + 1 M ← (M) + 1 M ← (M) + 1 M ← (M) + 1	↓	-	-	↑	↑	-	DIR INH INH IX1 IX SP1	3C 4C 5C 6C 7C 9E6C	dd ff ff	4 1 1 4 3 5
JMP <i>opr</i> JMP <i>opr</i> JMP <i>opr</i> ,X JMP <i>opr</i> ,X JMP ,X	Jump	PC ← Jump Address	-	-	-	-	-	-	DIR EXT IX2 IX1 IX	BC CC DC EC FC	dd hh ll ee ff ff	2 3 4 3 2
JSR <i>opr</i> JSR <i>opr</i> JSR <i>opr</i> ,X JSR <i>opr</i> ,X JSR ,X	Jump to Subroutine	PC ← (PC) + <i>n</i> ( <i>n</i> = 1, 2, or 3) Push (PCL); SP ← (SP) - 1 Push (PCH); SP ← (SP) - 1 PC ← Unconditional Address	-	-	-	-	-	-	DIR EXT IX2 IX1 IX	BD CD DD ED FD	dd hh ll ee ff ff	4 5 6 5 4
LDA # <i>opr</i> LDA <i>opr</i> LDA <i>opr</i> LDA <i>opr</i> ,X LDA <i>opr</i> ,X LDA ,X LDA <i>opr</i> ,SP LDA <i>opr</i> ,SP	Load A from M	A ← (M)	0	-	-	↑	↑	-	IMM DIR EXT IX2 IX1 IX SP1 SP2	A6 B6 C6 D6 E6 F6 9EE6 9ED6	ii dd hh ll ee ff ff ff ff ee ff	2 3 4 4 3 2 4 5
LDHX # <i>opr</i> LDHX <i>opr</i>	Load H:X from M	H:X ← (M:M + 1)	0	-	-	↑	↑	-	IMM DIR	45 55	ii jj dd	3 4
LDX # <i>opr</i> LDX <i>opr</i> LDX <i>opr</i> LDX <i>opr</i> ,X LDX <i>opr</i> ,X LDX ,X LDX <i>opr</i> ,SP LDX <i>opr</i> ,SP	Load X from M	X ← (M)	0	-	-	↑	↑	-	IMM DIR EXT IX2 IX1 IX SP1 SP2	AE BE CE DE EE FE 9EEE 9EDE	ii dd hh ll ee ff ff ff ff ee ff	2 3 4 4 3 2 4 5
LSL <i>opr</i> LSLA LSLX LSL <i>opr</i> ,X LSL ,X LSL <i>opr</i> ,SP	Logical Shift Left (Same as ASL)		↑	-	-	↑	↑	↑	DIR INH INH IX1 IX SP1	38 48 58 68 78 9E68	dd ff ff	4 1 1 4 3 5
LSR <i>opr</i> LSRA LSRX LSR <i>opr</i> ,X LSR ,X LSR <i>opr</i> ,SP	Logical Shift Right		↑	-	-	0	↑	↑	DIR INH INH IX1 IX SP1	34 44 54 64 74 9E64	dd ff ff	4 1 1 4 3 5
MOV <i>opr</i> , <i>opr</i> MOV <i>opr</i> ,X+ MOV # <i>opr</i> , <i>opr</i> MOV X+, <i>opr</i>	Move	(M) <sub>Destination</sub> ← (M) <sub>Source</sub> H:X ← (H:X) + 1 (IX+D, DIX+)	0	-	-	↑	↑	-	DD DIX+ IMD IX+D	4E 5E 6E 7E	dd dd dd ii dd dd	5 4 4 4
MUL	Unsigned multiply	X:A ← (X) × (A)	-	0	-	-	-	0	INH	42		5

Table 6-1. Instruction Set Summary (Continued)

Source Form	Operation	Description	Effect on CCR					Address Mode	Opcode	Operand	Cycles	
			V	H	I	N	Z					C
NEG <i>opr</i> NEGA NEGX NEG <i>opr,X</i> NEG ,X NEG <i>opr,SP</i>	Negate (Two's Complement)	$M \leftarrow -(M) = \$00 - (M)$ $A \leftarrow -(A) = \$00 - (A)$ $X \leftarrow -(X) = \$00 - (X)$ $M \leftarrow -(M) = \$00 - (M)$ $M \leftarrow -(M) = \$00 - (M)$	↓	-	-	↑	↑	↑	DIR INH INH IX1 IX SP1	30 40 50 60 70 9E60	dd ff ff	4 1 1 4 3 5
NOP	No Operation	None	-	-	-	-	-	-	INH	9D		1
NSA	Nibble Swap A	$A \leftarrow (A[3:0]:A[7:4])$	-	-	-	-	-	-	INH	62		3
ORA # <i>opr</i> ORA <i>opr</i> ORA <i>opr</i> ORA <i>opr,X</i> ORA <i>opr,X</i> ORA ,X ORA <i>opr,SP</i> ORA <i>opr,SP</i>	Inclusive OR A and M	$A \leftarrow (A)   (M)$	0	-	-	↑	↑	-	IMM DIR EXT IX2 IX1 IX SP1 SP2	AA BA CA DA EA FA 9EEA 9EDA	ii dd hh ll ee ff ff ff ff ee ff	2 3 4 4 3 2 4 5
PSHA	Push A onto Stack	Push (A); $SP \leftarrow (SP) - 1$	-	-	-	-	-	-	INH	87		2
PSHH	Push H onto Stack	Push (H); $SP \leftarrow (SP) - 1$	-	-	-	-	-	-	INH	8B		2
PSHX	Push X onto Stack	Push (X); $SP \leftarrow (SP) - 1$	-	-	-	-	-	-	INH	89		2
PULA	Pull A from Stack	$SP \leftarrow (SP) + 1$ ; Pull (A)	-	-	-	-	-	-	INH	86		2
PULH	Pull H from Stack	$SP \leftarrow (SP) + 1$ ; Pull (H)	-	-	-	-	-	-	INH	8A		2
PULX	Pull X from Stack	$SP \leftarrow (SP) + 1$ ; Pull (X)	-	-	-	-	-	-	INH	88		2
ROL <i>opr</i> ROLA ROLX ROL <i>opr,X</i> ROL ,X ROL <i>opr,SP</i>	Rotate Left through Carry		↓	-	-	↑	↑	↑	DIR INH INH IX1 IX SP1	39 49 59 69 79 9E69	dd ff ff ff	4 1 1 4 3 5
ROR <i>opr</i> RORA RORX ROR <i>opr,X</i> ROR ,X ROR <i>opr,SP</i>	Rotate Right through Carry		↑	-	-	↑	↑	↑	DIR INH INH IX1 IX SP1	36 46 56 66 76 9E66	dd ff ff ff	4 1 1 4 3 5
RSP	Reset Stack Pointer	$SP \leftarrow \$FF$	-	-	-	-	-	-	INH	9C		1
RTI	Return from Interrupt	$SP \leftarrow (SP) + 1$ ; Pull (CCR) $SP \leftarrow (SP) + 1$ ; Pull (A) $SP \leftarrow (SP) + 1$ ; Pull (X) $SP \leftarrow (SP) + 1$ ; Pull (PCH) $SP \leftarrow (SP) + 1$ ; Pull (PCL)	↓	↑	↑	↑	↑	↑	INH	80		7
RTS	Return from Subroutine	$SP \leftarrow SP + 1$ ; Pull (PCH) $SP \leftarrow SP + 1$ ; Pull (PCL)	-	-	-	-	-	-	INH	81		4

## Table 6-1. Instruction Set Summary (Continued)

Source Form	Operation	Description	Effect on CCR						Address Mode	Opcode	Operand	Cycles					
			V	H	I	N	Z	C									
SBC #opr SBC opr SBC opr SBC opr,X SBC opr,X SBC ,X SBC opr,SP SBC opr,SP	Subtract with Carry	$A \leftarrow (A) - (M) - (C)$							IMM DIR EXT IX2 IX1 IX SP1 SP2	A2 B2 C2 D2 E2 F2 9EE2 9ED2	ii dd hh ll ee ff ff ff ff ff	2 3 4 4 3 2 4 5					
SEC			Set Carry Bit	$C \leftarrow 1$	-	-	-	-	1	INH	99		1				
SEI			Set Interrupt Mask	$I \leftarrow 1$	-	-	1	-	-	INH	9B		2				
STA opr STA opr STA opr,X STA opr,X STA ,X STA opr,SP STA opr,SP			Store A in M	$M \leftarrow (A)$							DIR EXT IX2 IX1 IX SP1 SP2	B7 C7 D7 E7 F7 9EE7 9ED7	dd hh ll ee ff ff ff ff ff	3 4 4 3 2 4 5			
STHX opr					Store H:X in M	$(M:M + 1) \leftarrow (H:X)$	0	-	-	↑	↑	DIR	35	dd	4		
STOP					Enable $\overline{IRQ}$ Pin; Stop Oscillator	$I \leftarrow 0$ ; Stop Oscillator	-	-	0	-	-	INH	8E		1		
STX opr STX opr STX opr,X STX opr,X STX ,X STX opr,SP STX opr,SP					Store X in M	$M \leftarrow (X)$							DIR EXT IX2 IX1 IX SP1 SP2	BF CF DF EF FF 9EEF 9EDF	dd hh ll ee ff ff ff ff ff	3 4 4 3 2 4 5	
SUB #opr SUB opr SUB opr SUB opr,X SUB opr,X SUB ,X SUB opr,SP SUB opr,SP							Subtract	$A \leftarrow (A) - (M)$							IMM DIR EXT IX2 IX1 IX SP1 SP2	A0 B0 C0 D0 E0 F0 9EE0 9ED0	ii dd hh ll ee ff ff ff ff ff
SWI	Software Interrupt	$PC \leftarrow (PC) + 1$ ; Push (PCL) $SP \leftarrow (SP) - 1$ ; Push (PCH) $SP \leftarrow (SP) - 1$ ; Push (X) $SP \leftarrow (SP) - 1$ ; Push (A) $SP \leftarrow (SP) - 1$ ; Push (CCR) $SP \leftarrow (SP) - 1$ ; $I \leftarrow 1$ PCH $\leftarrow$ Interrupt Vector High Byte PCL $\leftarrow$ Interrupt Vector Low Byte							-	-	1	-	-	INH	83		9
TAP	Transfer A to CCR	$CCR \leftarrow (A)$							↑	↑	↑	↑	↑	INH	84		2
TAX	Transfer A to X	$X \leftarrow (A)$	-	-					-	-	-	INH	97		1		
TPA	Transfer CCR to A	$A \leftarrow (CCR)$	-	-					-	-	-	INH	85		1		

Table 6-1. Instruction Set Summary (Continued)

Source Form	Operation	Description	Effect on CCR					Address Mode	Opcode	Operand	Cycles	
			V	H	I	N	Z					C
TST <i>opr</i> TSTA TSTX TST <i>opr,X</i> TST ,X TST <i>opr,SP</i>	Test for Negative or Zero	(A) – \$00 or (X) – \$00 or (M) – \$00	0	–	–	↑	↓	–	DIR INH INH IX1 IX SP1	3D 4D 5D 6D 7D 9E6D	dd ff ff	3 1 1 3 2 4
TSX	Transfer SP to H:X	H:X ← (SP) + 1	–	–	–	–	–	–	INH	95		2
TXA	Transfer X to A	A ← (X)	–	–	–	–	–	–	INH	9F		1
TXS	Transfer H:X to SP	(SP) ← (H:X) – 1	–	–	–	–	–	–	INH	94		2

A	Accumulator	<i>n</i>	Any bit
C	Carry/borrow bit	<i>opr</i>	Operand (one or two bytes)
CCR	Condition code register	PC	Program counter
dd	Direct address of operand	PCH	Program counter high byte
dd rr	Direct address of operand and relative offset of branch instruction	PCL	Program counter low byte
DD	Direct to direct addressing mode	REL	Relative addressing mode
DIR	Direct addressing mode	<i>rel</i>	Relative program counter offset byte
DIX+	Direct to indexed with post increment addressing mode	rr	Relative program counter offset byte
ee ff	High and low bytes of offset in indexed, 16-bit offset addressing	SP1	Stack pointer, 8-bit offset addressing mode
EXT	Extended addressing mode	SP2	Stack pointer 16-bit offset addressing mode
ff	Offset byte in indexed, 8-bit offset addressing	SP	Stack pointer
H	Half-carry bit	U	Undefined
H	Index register high byte	V	Overflow bit
hh ll	High and low bytes of operand address in extended addressing	X	Index register low byte
I	Interrupt mask	Z	Zero bit
ii	Immediate operand byte	&	Logical AND
IMD	Immediate source to direct destination addressing mode		Logical OR
IMM	Immediate addressing mode	⊕	Logical EXCLUSIVE OR
INH	Inherent addressing mode	( )	Contents of
IX	Indexed, no offset addressing mode	–( )	Negation (two's complement)
IX+	Indexed, no offset, post increment addressing mode	#	Immediate value
IX+D	Indexed with post increment to direct addressing mode	«	Sign extend
IX1	Indexed, 8-bit offset addressing mode	←	Loaded with
IX1+	Indexed, 8-bit offset, post increment addressing mode	?	If
IX2	Indexed, 16-bit offset addressing mode	:	Concatenated with
M	Memory location	↑	Set or cleared
N	Negative bit	–	Not affected

## 6.7 Opcode Map

See [Table 6-2](#).

**Table 6-2. Opcode Map**

MSB LSB	Bit Manipulation		Branch	Read-Modify-Write						Control			Register/Memory						
	DIR	DIR	REL	DIR	INH	INH	IX1	SP1	IX	INH	INH	IMM	DIR	EXT	IX2	SP2	IX1	SP1	IX
	0	1	2	3	4	5	6	9E6	7	8	9	A	B	C	D	9ED	E	9EE	F
0	BRSET0 3 DIR	BSET0 2 DIR	BRA 2 REL	NEG 2 DIR	NEGA 1 INH	NEGX 1 INH	NEG 2 IX1	NEG 3 SP1	NEG 3 IX	RTI 1 INH	BGE 2 REL	SUB 2 IMM	SUB 2 DIR	SUB 3 EXT	SUB 3 IX2	SUB 4 SP2	SUB 2 IX1	SUB 3 SP1	SUB 1 IX
1	BRCLR0 3 DIR	BCLR0 2 DIR	BRN 2 REL	CBEQ 3 DIR	CBEQA 3 IMM	CBEQX 3 IMM	CBEQ 3 IX1+	CBEQ 4 SP1	CBEQ 2 IX+	RTS 1 INH	BLT 2 REL	CMP 2 IMM	CMP 2 DIR	CMP 3 EXT	CMP 3 IX2	CMP 4 SP2	CMP 2 IX1	CMP 3 SP1	CMP 1 IX
2	BRSET1 3 DIR	BSET1 2 DIR	BHI 2 REL		MUL 1 INH	DIV 1 INH	NSA 1 INH		DAA 1 INH		BGT 2 REL	SBC 2 IMM	SBC 2 DIR	SBC 3 EXT	SBC 3 IX2	SBC 4 SP2	SBC 2 IX1	SBC 3 SP1	SBC 1 IX
3	BRCLR1 3 DIR	BCLR1 2 DIR	BLS 2 REL	COM 2 DIR	COMA 1 INH	COMX 1 INH	COM 2 IX1	COM 3 SP1	COM 3 IX	SWI 1 INH	BLE 2 REL	CPX 2 IMM	CPX 2 DIR	CPX 3 EXT	CPX 3 IX2	CPX 4 SP2	CPX 2 IX1	CPX 3 SP1	CPX 1 IX
4	BRSET2 3 DIR	BSET2 2 DIR	BCC 2 REL	LSR 2 DIR	LSRA 1 INH	LSRX 1 INH	LSR 2 IX1	LSR 3 SP1	LSR 1 IX	TAP 1 INH	TXS 1 INH	AND 2 IMM	AND 2 DIR	AND 3 EXT	AND 3 IX2	AND 4 SP2	AND 2 IX1	AND 3 SP1	AND 1 IX
5	BRCLR2 3 DIR	BCLR2 2 DIR	BCS 2 REL	STHX 2 DIR	LDHX 3 IMM	LDHX 2 DIR	CPHX 3 IMM		CPHX 2 DIR	TPA 1 INH	TSX 1 INH	BIT 2 IMM	BIT 2 DIR	BIT 3 EXT	BIT 3 IX2	BIT 4 SP2	BIT 2 IX1	BIT 3 SP1	BIT 1 IX
6	BRSET3 3 DIR	BSET3 2 DIR	BNE 2 REL	ROR 2 DIR	RORA 1 INH	RORX 1 INH	ROR 2 IX1	ROR 3 SP1	ROR 1 IX	PULA 1 INH		LDA 2 IMM	LDA 3 DIR	LDA 3 EXT	LDA 3 IX2	LDA 4 SP2	LDA 2 IX1	LDA 3 SP1	LDA 1 IX
7	BRCLR3 3 DIR	BCLR3 2 DIR	BEQ 2 REL	ASR 2 DIR	ASRA 1 INH	ASRX 1 INH	ASR 2 IX1	ASR 3 SP1	ASR 1 IX	PSHA 1 INH	TAX 1 INH	AIS 2 IMM	STA 2 DIR	STA 3 EXT	STA 3 IX2	STA 4 SP2	STA 2 IX1	STA 3 SP1	STA 1 IX
8	BRSET4 3 DIR	BSET4 2 DIR	BHCC 2 REL	LSL 2 DIR	LSLA 1 INH	LSLX 1 INH	LSL 2 IX1	LSL 3 SP1	LSL 1 IX	PULX 1 INH	CLC 1 INH	EOR 2 IMM	EOR 2 DIR	EOR 3 EXT	EOR 3 IX2	EOR 4 SP2	EOR 2 IX1	EOR 3 SP1	EOR 1 IX
9	BRCLR4 3 DIR	BCLR4 2 DIR	BHCS 2 REL	ROL 2 DIR	ROLA 1 INH	ROLX 1 INH	ROL 2 IX1	ROL 3 SP1	ROL 1 IX	PSHX 1 INH	SEC 1 INH	ADC 2 IMM	ADC 2 DIR	ADC 3 EXT	ADC 3 IX2	ADC 4 SP2	ADC 2 IX1	ADC 3 SP1	ADC 1 IX
A	BRSET5 3 DIR	BSET5 2 DIR	BPL 2 REL	DEC 2 DIR	DECA 1 INH	DECX 1 INH	DEC 2 IX1	DEC 3 SP1	DEC 1 IX	PULH 1 INH	CLI 1 INH	ORA 2 IMM	ORA 2 DIR	ORA 3 EXT	ORA 3 IX2	ORA 4 SP2	ORA 2 IX1	ORA 3 SP1	ORA 1 IX
B	BRCLR5 3 DIR	BCLR5 2 DIR	BMI 2 REL	DBNZ 3 DIR	DBNZA 2 INH	DBNZX 2 INH	DBNZ 3 IX1	DBNZ 4 SP1	DBNZ 2 IX	PSHH 1 INH	SEI 1 INH	ADD 2 IMM	ADD 2 DIR	ADD 3 EXT	ADD 3 IX2	ADD 4 SP2	ADD 2 IX1	ADD 3 SP1	ADD 1 IX
C	BRSET6 3 DIR	BSET6 2 DIR	BMC 2 REL	INC 2 DIR	INCA 1 INH	INCX 1 INH	INC 2 IX1	INC 3 SP1	INC 1 IX	CLRH 1 INH	RSP 1 INH		JMP 2 DIR	JMP 3 EXT	JMP 3 IX2		JMP 2 IX1		JMP 1 IX
D	BRCLR6 3 DIR	BCLR6 2 DIR	BMS 2 REL	TST 2 DIR	TSTA 1 INH	TSTX 1 INH	TST 2 IX1	TST 3 SP1	TST 1 IX		NOP 1 INH	BSR 2 REL	JSR 2 DIR	JSR 3 EXT	JSR 3 IX2		JSR 2 IX1		JSR 1 IX
E	BRSET7 3 DIR	BSET7 2 DIR	BIL 2 REL		MOV 3 DD	MOV 4 DIX+	MOV 3 IMD		MOV 2 IX+D	STOP 1 INH	*	LDX 2 IMM	LDX 2 DIR	LDX 3 EXT	LDX 3 IX2	LDX 4 SP2	LDX 2 IX1	LDX 3 SP1	LDX 1 IX
F	BRCLR7 3 DIR	BCLR7 2 DIR	BIH 2 REL	CLR 2 DIR	CLRA 1 INH	CLR 1 INH	CLR 2 IX1	CLR 3 SP1	CLR 1 IX	WAIT 1 INH	TXA 1 INH	AIX 2 IMM	STX 2 DIR	STX 3 EXT	STX 3 IX2	STX 4 SP2	STX 2 IX1	STX 3 SP1	STX 1 IX

INH Inherent  
 IMM Immediate  
 DIR Direct  
 EXT Extended  
 DD Direct-Direct  
 IX+D Indexed-Direct  
 REL Relative  
 IX Indexed, No Offset  
 IX1 Indexed, 8-Bit Offset  
 IX2 Indexed, 16-Bit Offset  
 IMM Immediate-Direct  
 DIX+ Direct-Indexed  
 SP1 Stack Pointer, 8-Bit Offset  
 SP2 Stack Pointer, 16-Bit Offset  
 IX+ Indexed, No Offset with Post Increment  
 IX1+ Indexed, 1-Byte Offset with Post Increment

\*Pre-byte for stack pointer indexed instructions

Low Byte of Opcode in Hexadecimal

MSB LSB	0
0	BRSET0 3 DIR

High Byte of Opcode in Hexadecimal  
 Cycles  
 Opcode Mnemonic  
 Number of Bytes / Addressing Mode



## Section 7. System Integration Module (SIM)

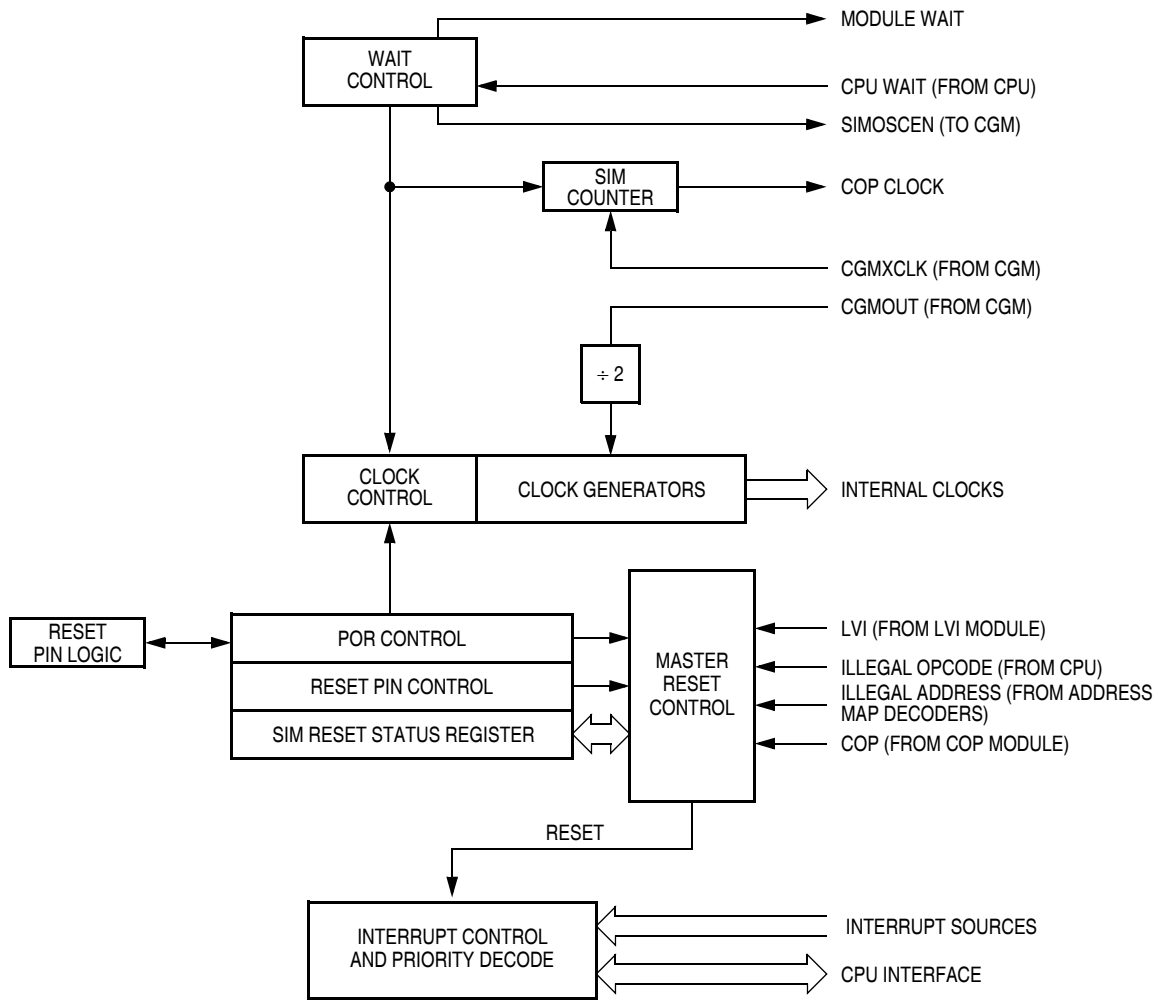
### 7.1 Contents

7.2	Introduction . . . . .	82
7.3	SIM Bus Clock Control and Generation . . . . .	85
7.3.1	Bus Timing . . . . .	85
7.3.2	Clock Start-Up from POR or LVI Reset. . . . .	85
7.3.3	Clocks in Wait Mode . . . . .	86
7.4	Reset and System Initialization. . . . .	86
7.4.1	External Pin Reset. . . . .	87
7.4.2	Active Resets from Internal Sources. . . . .	88
7.4.2.1	Power-On Reset . . . . .	89
7.4.2.2	Computer Operating Properly (COP) Reset. . . . .	90
7.4.2.3	Illegal Opcode Reset . . . . .	90
7.4.2.4	Illegal Address Reset. . . . .	90
7.4.2.5	Low-Voltage Inhibit (LVI) Reset . . . . .	91
7.5	SIM Counter . . . . .	91
7.5.1	SIM Counter During Power-On Reset. . . . .	91
7.5.2	SIM Counter and Reset States . . . . .	91
7.6	Exception Control . . . . .	92
7.6.1	Interrupts . . . . .	92
7.6.1.1	Hardware Interrupts . . . . .	94
7.6.1.2	SWI Instruction. . . . .	95
7.6.2	Reset. . . . .	96
7.6.3	Status Flag Protection in Break Mode. . . . .	96
7.7	Low-Power Mode . . . . .	96
7.7.1	Wait Mode . . . . .	97
7.7.2	SIM Break Status Register . . . . .	99
7.7.3	SIM Reset Status Register . . . . .	101
7.7.4	SIM Break Flag Control Register . . . . .	102

## 7.2 Introduction

This section describes the system integration module. Together with the CPU, the SIM controls all MCU activities. A block diagram of the SIM is shown in [Figure 7-1](#). [Figure 7-1](#) is a summary of the SIM I/O registers. The SIM is a system state controller that coordinates CPU and exception timing. The SIM is responsible for:

- Bus clock generation and control for CPU and peripherals
  - Wait/reset/break entry and recovery
  - Internal clock control
- Master reset control, including power-on reset (POR) and COP timeout
- Interrupt control:
  - Acknowledge timing
  - Arbitration control timing
  - Vector address generation
- CPU enable/disable timing
- Modular architecture expandable to 128 interrupt sources



**Figure 7-1. SIM Block Diagram**

# System Integration Module (SIM)

Addr.	Name		Bit 7	6	5	4	3	2	1	Bit 0	
\$FE00	SIM Break Status Register (SBSR)	Read:	R	R	R	R	R	R	SBSW	R	
		Write:							Note		
Note: Writing a logic 0 clears SBSW.		Reset:	0								
\$FE01	SIM Reset Status Register (SRSR)	Read:	POR	PIN	COP	ILOP	ILAD	0	LVI	0	
		Write:									
		Reset:	1	0	0	0	0	0	0	0	
\$FE03	SIM Break Flag Control Register (SBFCR)	Read:	BCFE	R	R	R	R	R	R	R	
		Write:									
		Reset:	0								

**Figure 7-2. SIM I/O Register Summary**

**Table 7-1** shows the internal signal names used in this section.

**Table 7-1. Signal Name Conventions**

Signal Name	Description
CGMXCLK	Buffered version of OSC1 from clock generator module (CGM)
CGMVCLK	PLL output
CGMOUT	PLL-based or OSC1-based clock output from CGM module (Bus clock = CGMOUT divided by two)
IAB	Internal address bus
IDB	Internal data bus
PORRST	Signal from the power-on reset module to the SIM
IRST	Internal reset signal
R/ $\overline{W}$	Read/write signal



### 7.3.3 Clocks in Wait Mode

In wait mode, the CPU clocks are inactive. The SIM also produces two sets of clocks for other modules. Refer to the wait mode subsection of each module to see if the module is active or inactive in wait mode. Some modules can be programmed to be active in wait mode.

## 7.4 Reset and System Initialization

The MCU has the following reset sources:

- Power-on reset module (POR)
- External reset pin ( $\overline{\text{RST}}$ )
- Computer operating properly module (COP)
- Low-voltage inhibit module (LVI)
- Illegal opcode
- Illegal address

All of these resets produce the vector \$FFFE–FFFF (\$FEFE–FEFF in monitor mode) and assert the internal reset signal (IRST). IRST causes all registers to be returned to their default values and all modules to be returned to their reset states.

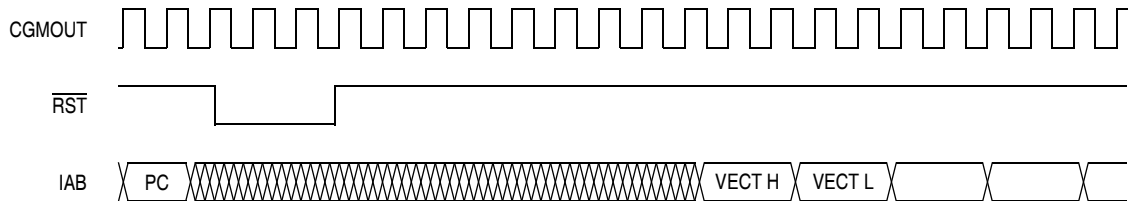
An internal reset clears the SIM counter (see [7.5 SIM Counter](#)), but an external reset does not. Each of the resets sets a corresponding bit in the SIM reset status register (SRSR). (See [7.7.3 SIM Reset Status Register](#).)

### 7.4.1 External Pin Reset

Pulling the asynchronous  $\overline{\text{RST}}$  pin low halts all processing. The PIN bit of the SIM reset status register (SRSR) is set as long as  $\overline{\text{RST}}$  is held low for a minimum of 67 CGMXCLK cycles, assuming that neither the POR nor the LVI was the source of the reset. See [Table 7-2](#) for details. [Figure 7-4](#) shows the relative timing.

**Table 7-2. PIN Bit Set Timing**

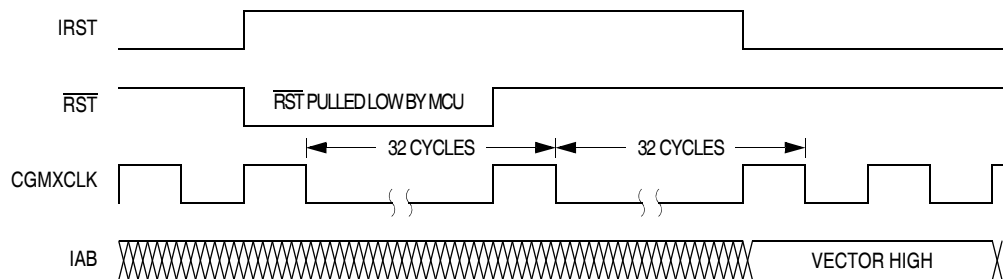
Reset Type	Number of Cycles Required to Set PIN
POR/LVI	4163 (4096 + 64 + 3)
All Others	67 (64 + 3)



**Figure 7-4. External Reset Timing**

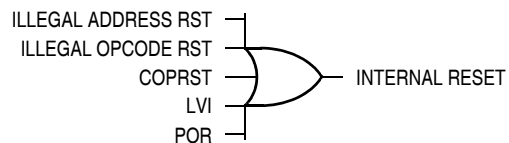
## 7.4.2 Active Resets from Internal Sources

All internal reset sources actively pull the  $\overline{\text{RST}}$  pin low for 32 CGMXCLK cycles to allow resetting of external peripherals. The internal reset signal IRST continues to be asserted for an additional 32 cycles. (See [Figure 7-5](#).) An internal reset can be caused by an illegal address, illegal opcode, COP timeout, LVI, or POR. (See [Figure 7-6](#).) Note that for LVI or POR resets, the SIM cycles through 4096 CGMXCLK cycles during which the SIM forces the  $\overline{\text{RST}}$  pin low. The internal reset signal then follows the sequence from the falling edge of  $\overline{\text{RST}}$  shown in [Figure 7-5](#).



**Figure 7-5. Internal Reset Timing**

The COP reset is asynchronous to the bus clock.



**Figure 7-6. Sources of Internal Reset**

The active reset feature allows the part to issue a reset to peripherals and other chips within a system built around the MCU.

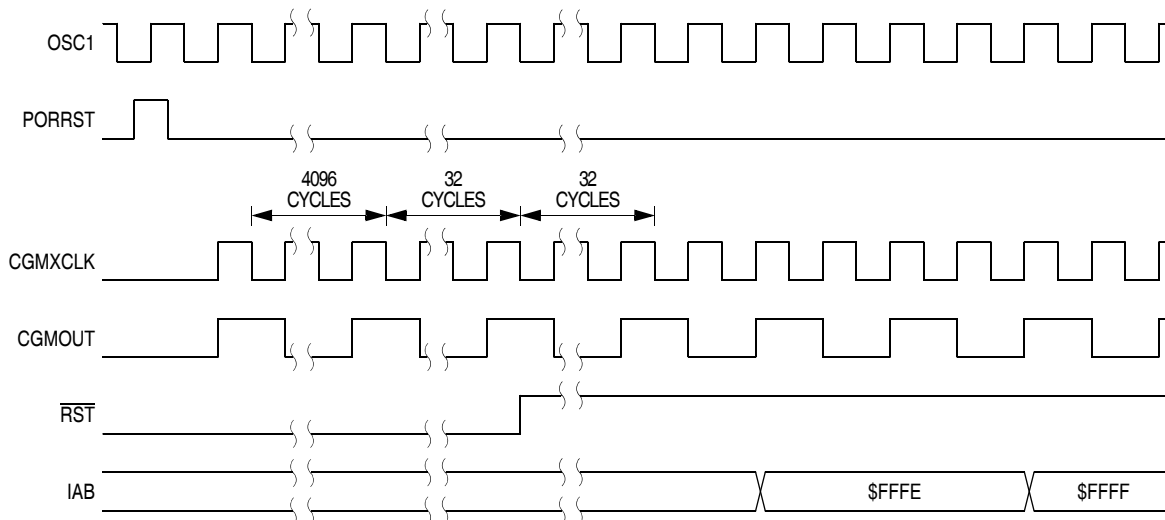


### 7.4.2.1 Power-On Reset

When power is first applied to the MCU, the power-on reset module (POR) generates a pulse to indicate that power-on has occurred. The external reset pin ( $\overline{\text{RST}}$ ) is held low while the SIM counter counts out 4096 CGMXCLK cycles. Sixty-four CGMXCLK cycles later, the CPU and memories are released from reset to allow the reset vector sequence to occur.

At power-on, the following events occur:

- A POR pulse is generated.
- The internal reset signal is asserted.
- The SIM enables CGMOUT.
- Internal clocks to the CPU and modules are held inactive for 4096 CGMXCLK cycles to allow stabilization of the oscillator.
- The  $\overline{\text{RST}}$  pin is driven low during the oscillator stabilization time.
- The POR bit of the SIM reset status register (SRSR) is set and all other bits in the register are cleared.



**Figure 7-7. POR Recovery**

### 7.4.2.2 Computer Operating Properly (COP) Reset

An input to the SIM is reserved for the COP reset signal. The overflow of the COP counter causes an internal reset and sets the COP bit in the SIM reset status register (SRSR). The SIM actively pulls down the  $\overline{\text{RST}}$  pin for all internal reset sources.

To prevent a COP module timeout, write any value to location \$FFFF. Writing to location \$FFFF clears the COP counter and bits 12 through 4 of the SIM counter. The SIM counter output, which occurs at least every  $2^{13} - 2^4$  CGMXCLK cycles, drives the COP counter. The COP should be serviced as soon as possible out of reset to guarantee the maximum amount of time before the first timeout.

The COP module is disabled if the  $\overline{\text{RST}}$  pin or the  $\overline{\text{IRQ1}}/V_{\text{PP}}$  pin is held at  $V_{\text{DD}} + V_{\text{HI}}$  while the MCU is in monitor mode. The COP module can be disabled only through combinational logic conditioned with the high voltage signal on the  $\overline{\text{RST}}$  or the  $\overline{\text{IRQ1}}/V_{\text{PP}}$  pin. This prevents the COP from becoming disabled as a result of external noise. During a break state,  $V_{\text{DD}} + V_{\text{HI}}$  on the  $\overline{\text{RST}}$  pin disables the COP module.

### 7.4.2.3 Illegal Opcode Reset

The SIM decodes signals from the CPU to detect illegal instructions. An illegal instruction sets the ILOP bit in the SIM reset status register (SRSR) and causes a reset.

Because the MC68HC708MP16 has stop mode disabled, execution of the STOP instruction will cause an illegal opcode reset.

### 7.4.2.4 Illegal Address Reset

An opcode fetch from addresses other than EPROM or RAM addresses generates an illegal address reset. The SIM verifies that the CPU is fetching an opcode prior to asserting the ILAD bit in the SIM reset status register (SRSR) and resetting the MCU. A data fetch from an unmapped address does not generate a reset.

### 7.4.2.5 Low-Voltage Inhibit (LVI) Reset

The low-voltage inhibit module (LVI) asserts its output to the SIM when the  $V_{DD}$  voltage falls to the  $LVI_{TRIPF}$  voltage and remains at or below that level for at least nine consecutive CPU cycles. The LVI bit in the SIM reset status register (SRSR) is set, and the external reset pin ( $\overline{RST}$ ) is held low while the SIM counter counts out 4096 CGMXCLK cycles. Sixty-four CGMXCLK cycles later, the CPU is released from reset to allow the reset vector sequence to occur. The SIM actively pulls down the  $\overline{RST}$  pin for all internal reset sources.

## 7.5 SIM Counter

The SIM counter is used by the power-on reset module (POR) to allow the oscillator time to stabilize before enabling the internal bus (IBUS) clocks. The SIM counter also serves as a prescaler for the computer operating properly module (COP). The SIM counter overflow supplies the clock for the COP module. The SIM counter is 13 bits long and is clocked by the falling edge of CGMXCLK.

### 7.5.1 SIM Counter During Power-On Reset

The power-on reset module (POR) detects power applied to the MCU. At power-on, the POR circuit asserts the signal PORRST. Once the SIM is initialized, it enables the clock generation module (CGM) to drive the bus clock state machine.

### 7.5.2 SIM Counter and Reset States

External reset has no effect on the SIM counter. The SIM counter is free-running after all reset states. (See [7.4.2 Active Resets from Internal Sources](#) for counter control and internal reset recovery sequences.)

## 7.6 Exception Control

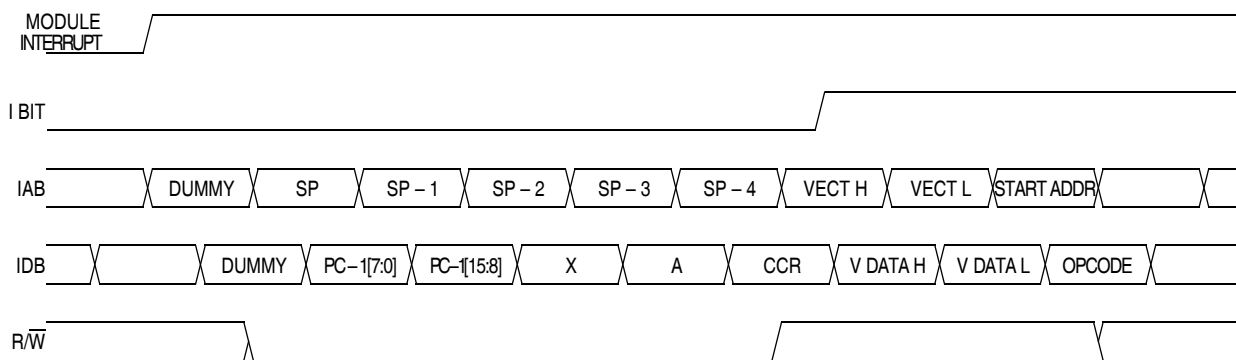
Normal, sequential program execution can be changed in three different ways:

- Interrupts
  - Maskable hardware CPU interrupts
  - Non-maskable software interrupt instruction (SWI)
- Reset
- Break interrupts

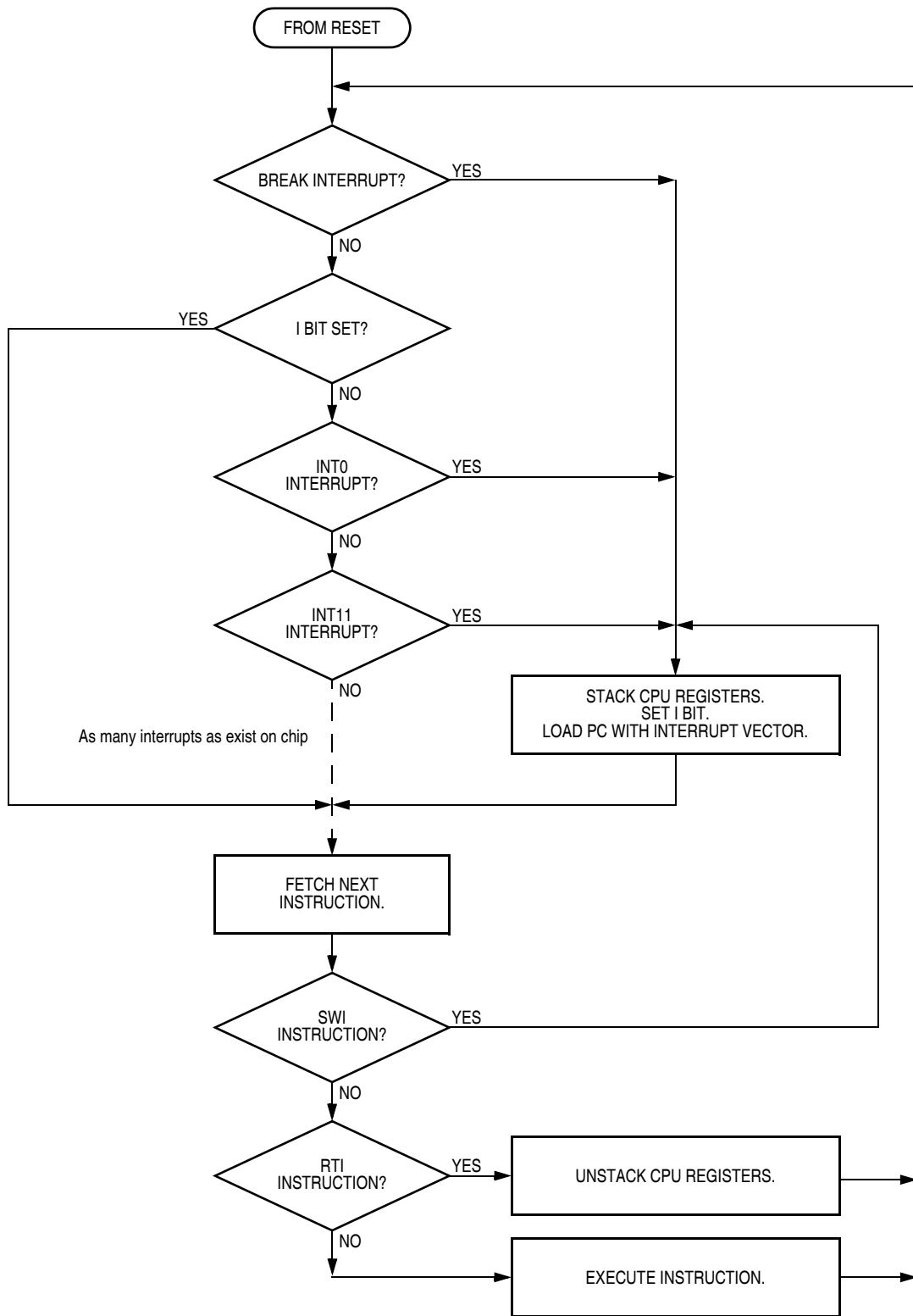
### 7.6.1 Interrupts

At the beginning of an interrupt, the CPU saves the CPU register contents on the stack and sets the interrupt mask (I bit) to prevent additional interrupts. At the end of an interrupt, the RTI instruction recovers the CPU register contents from the stack so that normal processing can resume. [Figure 7-8](#) shows interrupt entry timing. [Figure 7-10](#) shows interrupt recovery timing.

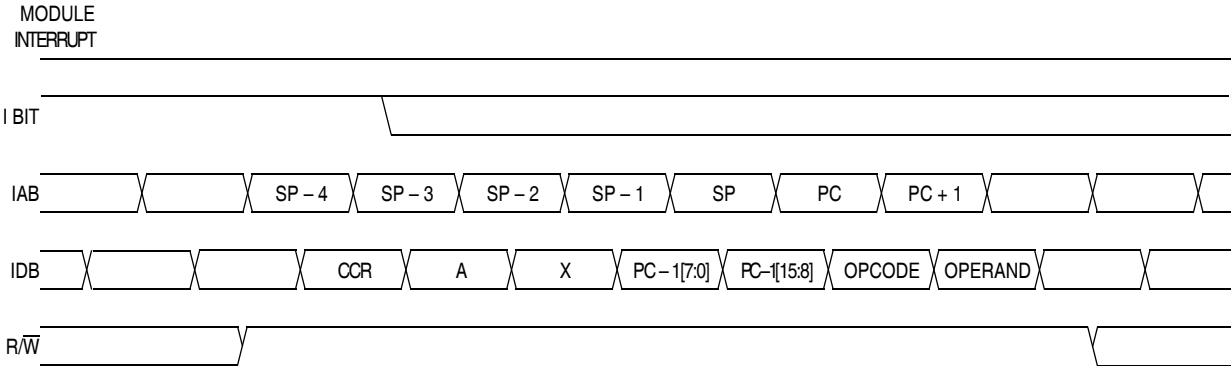
Interrupts are latched, and arbitration is performed in the SIM at the start of interrupt processing. The arbitration result is a constant that the CPU uses to determine which vector to fetch. Once an interrupt is latched by the SIM, no other interrupt can take precedence, regardless of priority, until the latched interrupt is serviced (or the I bit is cleared). (See [Figure 7-9](#).)



**Figure 7-8. Interrupt Entry**



**Figure 7-9. Interrupt Processing**

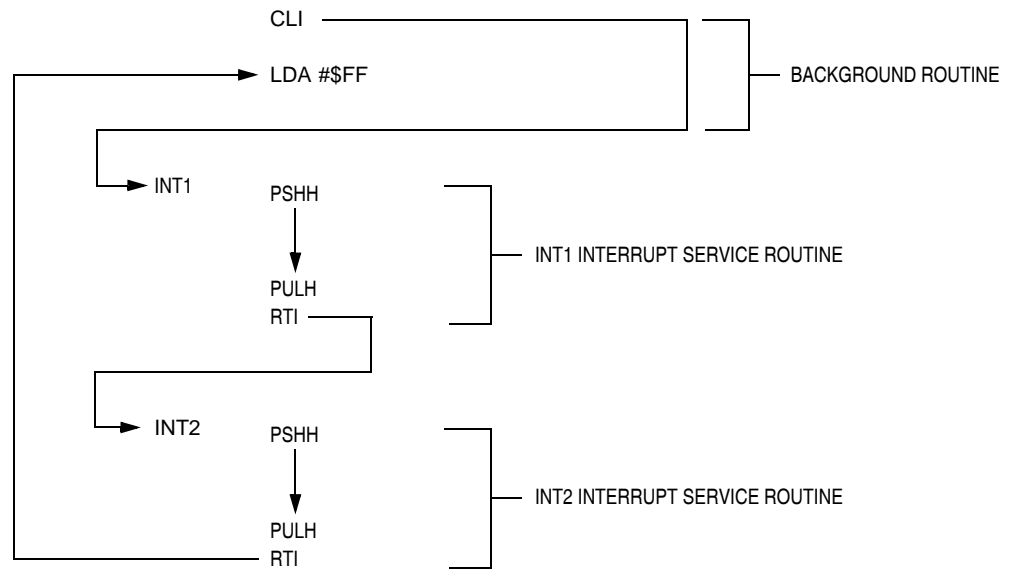


**Figure 7-10. Interrupt Recovery**

### 7.6.1.1 Hardware Interrupts

A hardware interrupt does not stop the current instruction. Processing of a hardware interrupt begins after completion of the current instruction. When the current instruction is complete, the SIM checks all pending hardware interrupts. If interrupts are not masked (I bit clear in the condition code register), and if the corresponding interrupt enable bit is set, the SIM proceeds with interrupt processing; otherwise, the next instruction is fetched and executed.

If more than one interrupt is pending at the end of an instruction execution, the highest priority interrupt is serviced first. [Figure 7-11](#) demonstrates what happens when two interrupts are pending. If an interrupt is pending upon exit from the original interrupt service routine, the pending interrupt is serviced before the LDA instruction is executed.



**Figure 7-11. Interrupt Recognition Example**

The LDA opcode is prefetched by both the INT1 and INT2 RTI instructions. However, in the case of the INT1 RTI prefetch, this is a redundant operation.

**NOTE:** *To maintain compatibility with the M6805 Family, the H register is not pushed on the stack during interrupt entry. If the interrupt service routine modifies the H register or uses the indexed addressing mode, software should save the H register and then restore it prior to exiting the routine.*

#### 7.6.1.2 SWI Instruction

The SWI instruction is a non-maskable instruction that causes an interrupt regardless of the state of the interrupt mask (I bit) in the condition code register.

**NOTE:** *A software interrupt pushes PC onto the stack. A software interrupt does not push PC - 1, as a hardware interrupt does.*

### 7.6.2 Reset

All reset sources always have equal and highest priority and cannot be arbitrated.

### 7.6.3 Status Flag Protection in Break Mode

The SIM controls whether status flags contained in other modules can be cleared during break mode. The user can select whether flags are protected from being cleared by properly initializing the break clear flag enable bit (BCFE) in the SIM break flag control register (SBFCR).

Protecting flags in break mode ensures that set flags will not be cleared while in break mode. This protection allows registers to be freely read and written during break mode without losing status flag information.

Setting the BCFE bit enables the clearing mechanisms. Once cleared in break mode, a flag remains cleared even when break mode is exited. Status flags with a two-step clearing mechanism — for example, a read of one register followed by the read or write of another — are protected, even when the first step is accomplished prior to entering break mode. Upon leaving break mode, execution of the second step will clear the flag as normal.

## 7.7 Low-Power Mode

Executing the WAIT instruction puts the MCU in a low-power-consumption mode for standby situations. The SIM holds the CPU in a non-clocked state. The operation of this mode is described below. WAIT clears the interrupt mask (I) in the condition code register, allowing interrupts to occur.

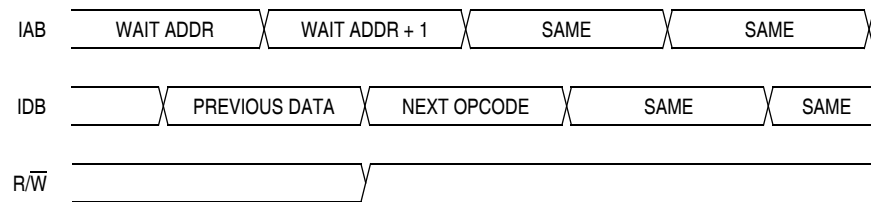


### 7.7.1 Wait Mode

In wait mode, the CPU clocks are inactive while the peripheral clocks continue to run. **Figure 7-12** shows the timing for wait mode entry.

A module that is active during wait mode can wake up the CPU with an interrupt if the interrupt is enabled. Stacking for the interrupt begins one cycle after the WAIT instruction during which the interrupt occurred. Refer to the wait mode subsection of each module to see if the module is active or inactive in wait mode. Some modules can be programmed to be active in wait mode.

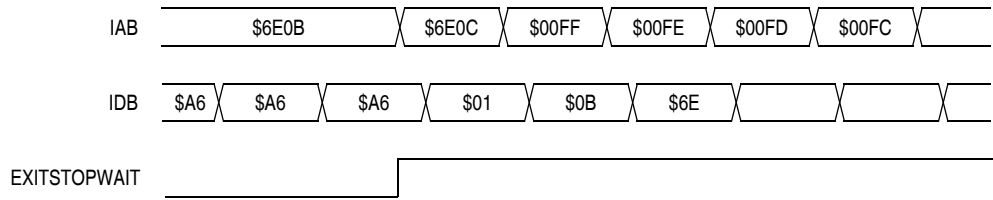
Wait mode can also be exited by a reset or break. A break interrupt during wait mode sets the SIM break stop/wait bit, SBSW, in the SIM break status register (SBSR). If the COP disable bit, COPD, in the configuration register is logic 0, then the computer operating properly module (COP) is enabled and remains active in wait mode.



NOTE: Previous data can be operand data or the WAIT opcode, depending on the last instruction.

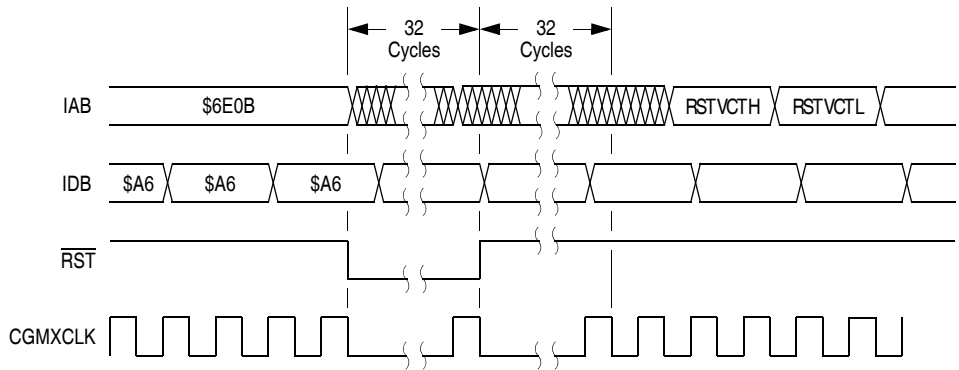
**Figure 7-12. Wait Mode Entry Timing**

Figure 7-13 and Figure 7-14 show the timing for WAIT recovery.



NOTE: EXITSTOPWAIT =  $\overline{\text{RST}}$  pin OR CPU interrupt OR break interrupt

**Figure 7-13. Wait Recovery from Interrupt or Break**



**Figure 7-14. Wait Recovery from Internal Reset**

## 7.7.2 SIM Break Status Register

The SIM break status register contains a flag to indicate that a break caused an exit from wait mode.

Address: \$FE00

	Bit 7	6	5	4	3	2	1	Bit 0
Read:	R	R5	R	R	R	R	SBSW	R
Write:							Note <sup>(1)</sup>	
Reset:							0	

R = Reserved for factory test

NOTE 1. Writing a logic 0 clears SBSW.

**Figure 7-15. SIM Break Status Register (SBSR)**

### SBSW — SIM Break Stop/Wait

This status bit is useful in applications requiring a return to wait mode after exiting from a break interrupt. Clear SBSW by writing a logic 0 to it. Reset clears SBSW.

1 = Wait mode was exited by break interrupt.

0 = Wait mode was not exited by break interrupt.

SBSW can be read within the break state SWI routine. The user can modify the return address on the stack by subtracting one from it. The following code is an example of this. Writing zero to the SBSW bit clears it.

## System Integration Module (SIM)

```
; This code works if the H register has been pushed onto the stack in the break
; service routine software. This code should be executed at the end of the break
; service routine software.
```

```
HIBYTE EQU 5
```

```
LOBYTE EQU 6
```

```
; If not SBSW, do RTI
```

```
BRCLR SBSW,SBSR, RETURN ; See if wait mode was exited by break.
;
```

```
TST LOBYTE,SP ; If RETURNLO is not zero,
```

```
BNE DOLO ; then just decrement low byte.
```

```
DEC HIBYTE,SP ; Else deal with high byte, too.
```

```
DOLO DEC LOBYTE,SP ; Point to WAIT opcode.
```


```
RETURN PULH ; Restore H register.
RTI
```

### 7.7.3 SIM Reset Status Register

This register contains six flags that show the source of the last reset. Clear the SIM reset status register by reading it. A power-on reset sets the POR bit and clears all other bits in the register.

Address: \$FE01

	Bit 7	6	5	4	3	2	1	Bit 0
Read:	POR	PIN	COP	ILOP	ILAD	0	LVI	0
Write:								
POR:	1	0	0	0	0	0	0	0

 = Unimplemented

**Figure 7-16. SIM Reset Status Register (SRSR)**

**POR** — Power-On Reset Bit

- 1 = Last reset caused by POR circuit
- 0 = Read of SRSR

**PIN** — External Reset Bit

- 1 = Last reset caused by external reset pin ( $\overline{RST}$ )
- 0 = POR or read of SRSR

**COP** — Computer Operating Properly Reset Bit

- 1 = Last reset caused by COP counter
- 0 = POR or read of SRSR

**ILOP** — Illegal Opcode Reset Bit

- 1 = Last reset caused by an illegal opcode
- 0 = POR or read of SRSR

**ILAD** — Illegal Address Reset Bit (opcode fetches only)

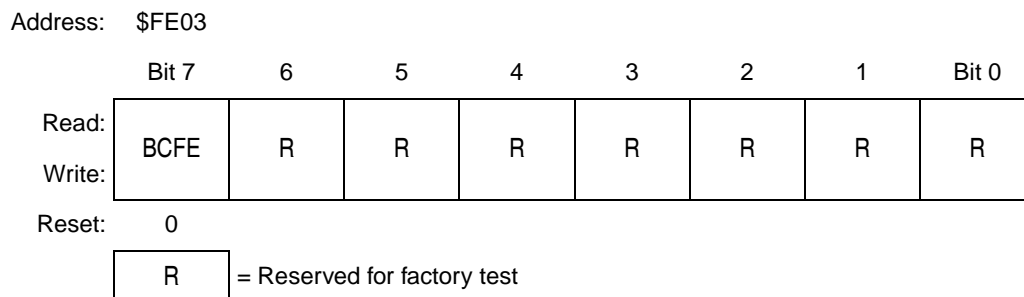
- 1 = Last reset caused by an opcode fetch from an illegal address
- 0 = POR or read of SRSR

**LVI** — Low-Voltage Inhibit Reset Bit

- 1 = Last reset was caused by the LVI circuit
- 0 = POR or read of SRSR

## 7.7.4 SIM Break Flag Control Register

The SIM break control register contains a bit that enables software to clear status bits while the MCU is in a break state.



**Figure 7-17. SIM Break Flag Control Register (SBFCR)**

### BCFE — Break Clear Flag Enable Bit

This read/write bit enables software to clear status bits by accessing status registers while the MCU is in a break state. To clear status bits during the break state, the BCFE bit must be set.

1 = Status bits clearable during break

0 = Status bits not clearable during break

## Section 8. Clock Generator Module (CGM)

### 8.1 Contents

8.2	Introduction	104
8.3	Features	104
8.4	Functional Description	105
8.4.1	Crystal Oscillator Circuit	105
8.4.2	Phase-Locked Loop Circuit (PLL)	107
8.4.2.1	PLL Circuits	107
8.4.2.2	Acquisition and Tracking Modes	109
8.4.2.3	Manual and Automatic PLL Bandwidth Modes	109
8.4.2.4	Programming the PLL	111
8.4.2.5	Special Programming Exceptions	112
8.4.3	Base Clock Selector Circuit	112
8.4.4	CGM External Connections	113
8.5	I/O Signals	114
8.5.1	Crystal Amplifier Input Pin (OSC1)	114
8.5.2	Crystal Amplifier Output Pin (OSC2)	114
8.5.3	External Filter Capacitor Pin (CGMXFC)	114
8.5.4	PLL Analog Power Pin ( $V_{DDA}$ )	115
8.5.5	Oscillator Enable Signal (SIMOSCEN)	115
8.5.6	Crystal Output Frequency Signal (CGMXCLK)	115
8.5.7	CGM Base Clock Output (CGMOUT)	115
8.5.8	CGM CPU Interrupt (CGMINT)	116
8.6	CGM Registers	116
8.6.1	PLL Control Register	117
8.6.2	PLL Bandwidth Control Register	119
8.6.3	PLL Programming Register	121
8.7	Interrupts	123
8.8	Wait Mode	123
8.9	CGM During Break Mode	124

8.10	Acquisition/Lock Time Specifications .....	124
8.10.1	Acquisition/Lock Time Definitions .....	124
8.10.2	Parametric Influences on Reaction Time .....	126
8.10.3	Choosing a Filter Capacitor .....	127
8.10.4	Reaction Time Calculation .....	127

## 8.2 Introduction

This section describes the clock generator module (CGM, Version A). The CGM generates the crystal clock signal, CGMXCLK, which operates at the frequency of the crystal. The CGM also generates the base clock signal, CGMOUT, from which the system integration module (SIM) derives the system clocks. CGMOUT is based on either the crystal clock divided by two or the phase-locked loop (PLL) clock, CGMVCLK, divided by two. The PLL is a frequency generator designed for use with crystals or ceramic resonators. The PLL can generate an 8-MHz bus frequency without using a 32-MHz crystal.

## 8.3 Features

Features of the CGM include the following:

- Phase-locked loop with output frequency in integer multiples of the crystal reference
- Programmable hardware voltage-controlled oscillator (VCO) for low-jitter operation
- Automatic bandwidth control mode for low-jitter operation
- Automatic frequency lock detector
- CPU interrupt on entry or exit from locked condition



## 8.4 Functional Description

The CGM consists of three major submodules:

- Crystal oscillator circuit — The crystal oscillator circuit generates the constant crystal frequency clock, CGMXCLK.
- Phase-locked loop (PLL) — The PLL generates the programmable VCO frequency clock CGMVCLK.
- Base clock selector circuit — This software-controlled circuit selects either CGMXCLK divided by two or the VCO clock, CGMVCLK, divided by two as the base clock, CGMOUT. The SIM derives the system clocks from CGMOUT.

**Figure 8-1** shows the structure of the CGM.

### 8.4.1 Crystal Oscillator Circuit

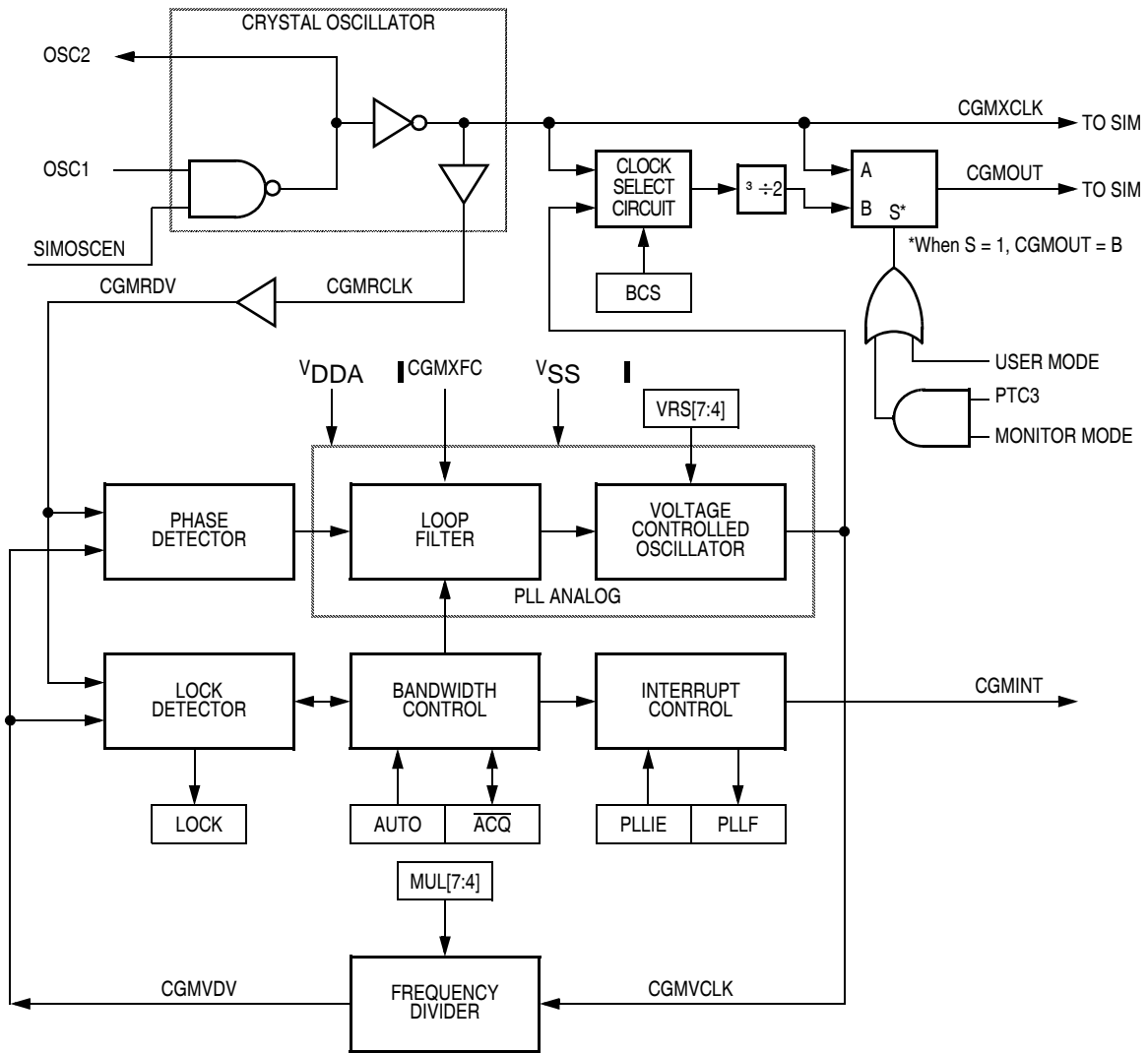
The crystal oscillator circuit consists of an inverting amplifier and an external crystal. The OSC1 pin is the input to the amplifier and the OSC2 pin is the output. The SIMOSCEN signal from the system integration module (SIM) enables the crystal oscillator circuit.

The CGMXCLK signal is the output of the crystal oscillator circuit and runs at a rate equal to the crystal frequency. CGMXCLK is then buffered to produce CGMRCLK, the PLL reference clock.

CGMXCLK can be used by other modules which require precise timing for operation. The duty cycle of CGMXCLK is not guaranteed to be 50% and depends on external factors, including the crystal and related external components.

An externally generated clock also can feed the OSC1 pin of the crystal oscillator circuit. Connect the external clock to the OSC1 pin and let the OSC2 pin float.

# Clock Generator Module (CGM)



**Figure 8-1. CGM Block Diagram**

Addr.	Name		Bit 7	6	5	4	3	2	1	Bit 0
\$FE0B	PLL Control Register (PCTL)	Read:	PLLIE	PLL F	PLLON	BCS	1	1	1	1
		Write:								
		Reset:	0	0	1	0	1	1	1	1
\$FE0C	PLL Bandwidth Control Register (PBWC)	Read:	AUTO	LOCK	ACQ	XLD	0	0	0	0
		Write:								
		Reset:	0	0	0	0	0	0	0	0
\$FE0D	PLL Programming Register (PPG)	Read:	MUL7	MUL6	MUL5	MUL4	VRS7	VRS6	VRS5	VRS4
		Write:								
		Reset:	0	1	1	0	0	1	1	0

= Unimplemented

**Figure 8-2. CGM I/O Register Summary**

### 8.4.2 Phase-Locked Loop Circuit (PLL)

The PLL is a frequency generator that can operate in either acquisition mode or tracking mode, depending on the accuracy of the output frequency. The PLL can change between acquisition and tracking modes either automatically or manually.

#### 8.4.2.1 PLL Circuits

The PLL consists of the following circuits:

- Voltage-controlled oscillator (VCO)
- Modulo VCO frequency divider
- Phase detector
- Loop filter
- Lock detector

The operating range of the VCO is programmable for a wide range of frequencies and for maximum immunity to external noise, including supply and CGMXFC noise. The VCO frequency is bound to a range from roughly one-half to twice the center-of-range frequency,  $f_{VRS}$ . Modulating the voltage on the CGMXFC pin changes the frequency within this range. By design,  $f_{VRS}$  is equal to the nominal center-of-range frequency,  $f_{NOM}$ , (4.9152 MHz) times a linear factor  $L$ , or  $(L)f_{NOM}$ .

CGMRCLK is the PLL reference clock, a buffered version of CGMXCLK. CGMRCLK runs at a frequency,  $f_{RCLK}$ , and is fed to the PLL through a buffer. The buffer output is the final reference clock, CGMRDV, running at a frequency  $f_{RDV} = f_{RCLK}$ .

The VCO's output clock, CGMVCLK, running at a frequency  $f_{VCLK}$ , is fed back through a programmable modulo divider. The modulo divider reduces the VCO clock by a factor,  $N$ . The divider's output is the VCO feedback clock, CGMVDV, running at a frequency  $f_{VDV} = f_{VCLK}/N$ . (See [8.4.2.4 Programming the PLL](#) for more information.)

The phase detector then compares the VCO feedback clock, CGMVDV, with the final reference clock, CGMRDV. A correction pulse is generated based on the phase difference between the two signals. The loop filter then slightly alters the DC voltage on the external capacitor connected to CGMXFC based on the width and direction of the correction pulse. The filter can make fast or slow corrections depending on its mode, described in [8.4.2.2 Acquisition and Tracking Modes](#). The value of the external capacitor and the reference frequency determines the speed of the corrections and the stability of the PLL.

The lock detector compares the frequencies of the VCO feedback clock, CGMVDV, and the final reference clock, CGMRDV. Therefore, the speed of the lock detector is directly proportional to the final reference frequency  $f_{RDV}$ . The circuit determines the mode of the PLL and the lock condition based on this comparison.

### 8.4.2.2 Acquisition and Tracking Modes

The PLL filter is manually or automatically configurable into one of two operating modes:

- Acquisition mode — In acquisition mode, the filter can make large frequency corrections to the VCO. This mode is used at PLL start-up or when the PLL has suffered a severe noise hit and the VCO frequency is far off the desired frequency. When in acquisition mode, the  $\overline{ACQ}$  bit is clear in the PLL bandwidth control register. (See [8.6.2 PLL Bandwidth Control Register](#).)
- Tracking mode — In tracking mode, the filter makes only small corrections to the frequency of the VCO. PLL jitter is much lower in tracking mode, but the response to noise is also slower. The PLL enters tracking mode when the VCO frequency is nearly correct, such as when the PLL is selected as the base clock source. (See [8.4.3 Base Clock Selector Circuit](#).) The PLL is automatically in tracking mode when not in acquisition mode or when the  $\overline{ACQ}$  bit is set.

### 8.4.2.3 Manual and Automatic PLL Bandwidth Modes

The PLL can change the bandwidth or operational mode of the loop filter manually or automatically.

In automatic bandwidth control mode (AUTO = 1), the lock detector automatically switches between acquisition and tracking modes. Automatic bandwidth control mode also is used to determine when the VCO clock, CGMVCLK, is safe to use as the source for the base clock, CGMOUT. (See [8.6.2 PLL Bandwidth Control Register](#).) If PLL interrupts are enabled, the software can wait for a PLL interrupt request and then check the LOCK bit. If interrupts are disabled, software can poll the LOCK bit continuously (during PLL start-up, usually) or at periodic intervals. In either case, when the LOCK bit is set, the VCO clock is safe to use as the source for the base clock. (See [8.4.3 Base Clock Selector Circuit](#).) If the VCO is selected as the source for the base clock and the LOCK bit is clear, the PLL has suffered a severe noise hit and the software must take appropriate action, depending on the application. (See [8.7 Interrupts](#) for information and precautions on using interrupts.)

The following conditions apply when the PLL is in automatic bandwidth control mode:

- The  $\overline{\text{ACQ}}$  bit (see [8.6.2 PLL Bandwidth Control Register](#)) is a read-only indicator of the mode of the filter. (See [8.4.2.2 Acquisition and Tracking Modes](#).)
- The  $\overline{\text{ACQ}}$  bit is set when the VCO frequency is within a certain tolerance,  $\Delta_{\text{TRK}}$ , and is cleared when the VCO frequency is out of a certain tolerance,  $\Delta_{\text{UNT}}$ . (See [8.10 Acquisition/Lock Time Specifications](#) for more information.)
- The LOCK bit is a read-only indicator of the locked state of the PLL.
- The LOCK bit is set when the VCO frequency is within a certain tolerance,  $\Delta_{\text{LOCK}}$ , and is cleared when the VCO frequency is out of a certain tolerance,  $\Delta_{\text{UNL}}$ . (See [8.10 Acquisition/Lock Time Specifications](#) for more information.)
- CPU interrupts can occur if enabled ( $\text{PLLIE} = 1$ ) when the PLL's lock condition changes, toggling the LOCK bit. (See [8.6.1 PLL Control Register](#).)

The PLL also may operate in manual mode ( $\text{AUTO} = 0$ ). Manual mode is used by systems that do not require an indicator of the lock condition for proper operation. Such systems typically operate well below  $f_{\text{BUSMAX}}$  and require fast start-up. The following conditions apply when in manual mode:

- $\overline{\text{ACQ}}$  is a writable control bit that controls the mode of the filter. Before turning on the PLL in manual mode, the  $\overline{\text{ACQ}}$  bit must be clear.
- Before entering tracking mode ( $\overline{\text{ACQ}} = 1$ ), software must wait a given time,  $t_{\text{ACQ}}$  (see [8.10 Acquisition/Lock Time Specifications](#)), after turning on the PLL by setting PLLON in the PLL control register (PCTL).
- Software must wait a given time,  $t_{\text{AL}}$ , after entering tracking mode before selecting the PLL as the clock source to CGMOUT ( $\text{BCS} = 1$ ).
- The LOCK bit is disabled.
- CPU interrupts from the CGM are disabled.

#### 8.4.2.4 Programming the PLL

The following procedure shows how to program the PLL.

**NOTE:** *The round function in the following equations means that the real number should be rounded to the nearest integer number.*

1. Choose the desired bus frequency,  $f_{\text{BUSDES}}$ .
2. Calculate the desired VCO frequency (four times the desired bus frequency).

$$f_{\text{VCLKDES}} = 4 \times f_{\text{BUSDES}}$$

3. Choose a practical PLL reference frequency,  $f_{\text{RCLK}}$ .
4. Select a VCO frequency multiplier, N.

$$N = \text{round}\left(\frac{f_{\text{VCLKDES}}}{f_{\text{RCLK}}}\right)$$

5. Calculate and verify the adequacy of the VCO and bus frequencies  $f_{\text{VCLK}}$  and  $f_{\text{BUS}}$ .

$$f_{\text{VCLK}} = N \times f_{\text{RCLK}}$$

$$f_{\text{BUS}} = (f_{\text{VCLK}})/4$$

6. Select a VCO linear range multiplier, L.

$$L = \text{round}\left(\frac{f_{\text{VCLK}}}{f_{\text{NOM}}}\right)$$

where  $f_{\text{NOM}} = 4.9152$  MHz

7. Calculate and verify the adequacy of the VCO programmed center-of-range frequency  $f_{\text{VRS}}$ .

$$f_{\text{VRS}} = (L)f_{\text{NOM}}$$

8. Verify the choice of N and L by comparing  $f_{\text{VCLK}}$  to  $f_{\text{VRS}}$  and  $f_{\text{VCLKDES}}$ . For proper operation,  $f_{\text{VCLK}}$  must be within the application's tolerance of  $f_{\text{VCLKDES}}$ , and  $f_{\text{VRS}}$  must be as close as possible to  $f_{\text{VCLK}}$ .

**NOTE:** Exceeding the recommended maximum bus frequency or VCO frequency can crash the MCU.

9. Program the PLL registers accordingly:
  - a. In the upper four bits of the PLL programming register (PPG), program the binary equivalent of N.
  - b. In the lower four bits of the PLL programming register (PPG), program the binary equivalent of L.

### 8.4.2.5 Special Programming Exceptions

The programming method described in [8.4.2.4 Programming the PLL](#) does not account for possible exceptions. A value of zero for N or L is meaningless when used in the equations given. To account for these exceptions:

- A zero value for N is interpreted exactly the same as a value of one.
- A zero value for L disables the PLL and prevents its selection as the source for the base clock. (See [8.4.3 Base Clock Selector Circuit](#).)

### 8.4.3 Base Clock Selector Circuit

This circuit is used to select either the crystal clock, CGMXCLK, or the VCO clock, CGMVCLK, as the source of the base clock, CGMOUT. The two input clocks go through a transition control circuit that waits up to three CGMXCLK cycles and three CGMVCLK cycles to change from one clock source to the other. During this time, CGMOUT is held in stasis. The output of the transition control circuit is then divided by two to correct the duty cycle. Therefore, the bus clock frequency, which is one-half of the base clock frequency, is one-fourth the frequency of the selected clock (CGMXCLK or CGMVCLK).

The BCS bit in the PLL control register (PCTL) selects which clock drives CGMOUT. The VCO clock cannot be selected as the base clock source if the PLL is not turned on. The PLL cannot be turned off if the VCO clock is selected. The PLL cannot be turned on or off simultaneously with the



selection or deselection of the VCO clock. The VCO clock also cannot be selected as the base clock source if the factor L is programmed to a zero. This value would set up a condition inconsistent with the operation of the PLL, so that the PLL would be disabled and the crystal clock would be forced as the source of the base clock.

#### 8.4.4 CGM External Connections

In its typical configuration, the CGM requires seven external components. Five of these are for the crystal oscillator and two are for the PLL.

The crystal oscillator is normally connected in a Pierce oscillator configuration, as shown in [Figure 8-3](#). [Figure 8-3](#) shows only the logical representation of the internal components and may not represent actual circuitry. The oscillator configuration uses five components:

- Crystal,  $X_1$
- Fixed capacitor,  $C_1$
- Tuning capacitor,  $C_2$  (can also be a fixed capacitor)
- Feedback resistor,  $R_B$
- Series resistor,  $R_S$  (optional)

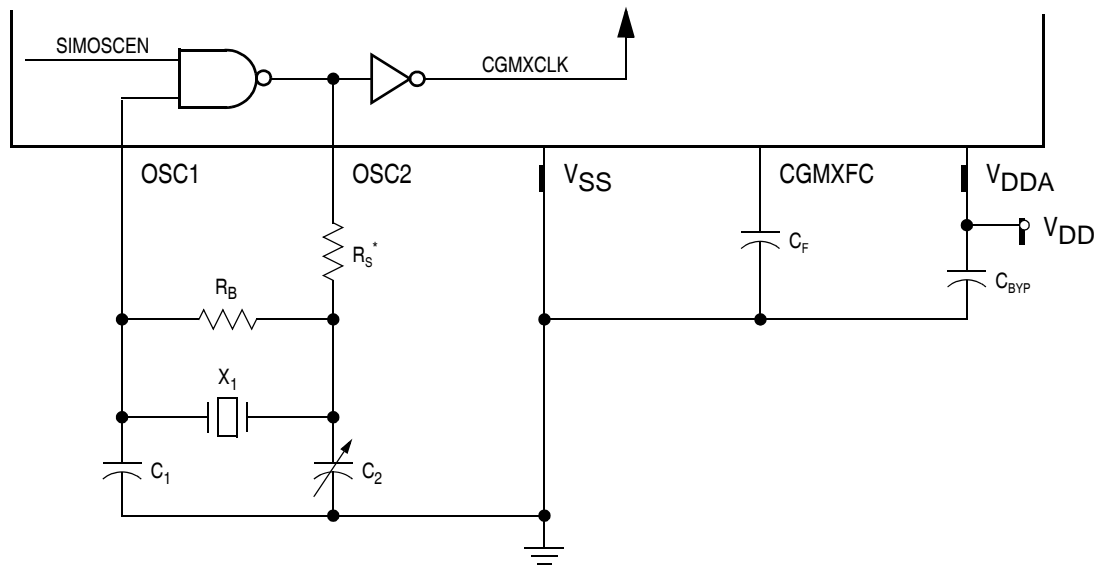
The series resistor ( $R_S$ ) is included in the diagram to follow strict Pierce oscillator guidelines and may not be required for all ranges of operation, especially with high frequency crystals. Refer to the crystal manufacturer's data for more information.

[Figure 8-3](#) also shows the external components for the PLL:

- Bypass capacitor,  $C_{BYP}$
- Filter capacitor,  $C_F$

Routing should be done with great care to minimize signal cross talk and noise. (See [8.10 Acquisition/Lock Time Specifications](#) for routing information and more information on the filter capacitor's value and its effects on PLL performance.)

## Clock Generator Module (CGM)



\* $R_S$  can be zero (shorted) when used with higher-frequency crystals. Refer to manufacturer's data.

**Figure 8-3. CGM External Connections**

### 8.5 I/O Signals

The following paragraphs describe the CGM I/O signals.

#### 8.5.1 Crystal Amplifier Input Pin (OSC1)

The OSC1 pin is an input to the crystal oscillator amplifier.

#### 8.5.2 Crystal Amplifier Output Pin (OSC2)

The OSC2 pin is the output of the crystal oscillator inverting amplifier.

#### 8.5.3 External Filter Capacitor Pin (CGMXFC)

The CGMXFC pin is required by the loop filter to filter out phase corrections. A small external capacitor is connected to this pin.

**NOTE:** To prevent noise problems,  $C_F$  should be placed as close to the CGMXFC pin as possible, with minimum routing distances and no routing of other signals across the  $C_F$  connection.

#### 8.5.4 PLL Analog Power Pin ( $V_{DDA}$ )

$V_{DDA}$  is a power pin used by the analog portions of the PLL. Connect the  $V_{DDA}$  pin to the same voltage potential as the  $V_{DD}$  pin.

**NOTE:** Route  $V_{DDA}$  carefully for maximum noise immunity and place bypass capacitors as close as possible to the package.

#### 8.5.5 Oscillator Enable Signal (SIMOSCEN)

The SIMOSCEN signal comes from the system integration module (SIM) and enables the oscillator and PLL.

#### 8.5.6 Crystal Output Frequency Signal (CGMXCLK)

CGMXCLK is the crystal oscillator output signal. It runs at the full speed of the crystal ( $f_{XCLK}$ ) and comes directly from the crystal oscillator circuit. **Figure 8-3** shows only the logical relation of CGMXCLK to OSC1 and OSC2 and may not represent the actual circuitry. The duty cycle of CGMXCLK is unknown and may depend on the crystal and other external factors. Also, the frequency and amplitude of CGMXCLK can be unstable at start-up.

#### 8.5.7 CGM Base Clock Output (CGMOUT)

CGMOUT is the clock output of the CGM. This signal goes to the SIM, which generates the MCU clocks. CGMOUT is a 50% duty cycle clock running at twice the bus frequency. CGMOUT is software programmable to be either the oscillator output, CGMXCLK, divided by two or the VCO clock, CGMVCLK, divided by two.

## 8.5.8 CGM CPU Interrupt (CGMINT)

CGMINT is the interrupt signal generated by the PLL lock detector.

## 8.6 CGM Registers

The following registers control and monitor operation of the CGM:

- PLL control register (PCTL) (See [8.6.1 PLL Control Register](#).)
- PLL bandwidth control register (PBWC) (See [8.6.2 PLL Bandwidth Control Register](#).)
- PLL programming register (PPG) ((See [8.6.3 PLL Programming Register](#).)

**Figure 8-4** is a summary of the CGM registers.


PCTL		Bit 7	6	5	4	3	2	1	Bit 0
Read:	PLLIE	PLLIF	PLLON	BCS	1	1	1	1	1
Write:									

PBWC		Bit 7	6	5	4	3	2	1	Bit 0
Read:	AUTO	LOCK	$\overline{ACQ}$	XLD	0	0	0	0	0
Write:									

PPG		Bit 7	6	5	4	3	2	1	Bit 0
Read:	MUL7	MUL6	MUL5	MUL4	VRS7	VRS6	VRS5	VRS4	
Write:									

 = Unimplemented

### NOTES:

1. When AUTO = 0, PLLIE is forced to logic 0 and is read-only.
2. When AUTO = 0, PLLIF and LOCK read as logic 0.
3. When AUTO = 1,  $\overline{ACQ}$  is read-only.
4. When PLLON = 0 or VRS[7:4] = \$0, BCS is forced to logic 0 and is read-only.
5. When PLLON = 1, the PLL programming register is read-only.
6. When BCS = 1, PLLON is forced set and is read-only.


**Figure 8-4. CGM I/O Register Summary**

### 8.6.1 PLL Control Register

The PLL control register contains the interrupt enable and flag bits, the on/off switch, the base clock selector bit.

Address: \$FE0B

	Bit 7	6	5	4	3	2	1	Bit 0
Read:	PILLIE	PLLF	PLLON	BCS	1	1	1	1
Write:								
Reset:	0	0	1	0	1	1	1	1

 = Unimplemented

**Figure 8-5. PLL Control Register (PCTL)**

#### PLLIE — PLL Interrupt Enable Bit

This read/write bit enables the PLL to generate an interrupt request when the LOCK bit toggles, setting the PLL flag, PLLF. When the AUTO bit in the PLL bandwidth control register (PBWC) is clear, PLLIE cannot be written and reads as logic 0. Reset clears the PLLIE bit.

- 1 = PLL interrupts enabled
- 0 = PLL interrupts disabled

#### PLLF — PLL Interrupt Flag Bit

This read-only bit is set whenever the LOCK bit toggles. PLLF generates an interrupt request if the PLLIE bit also is set. PLLF always reads as logic 0 when the AUTO bit in the PLL bandwidth control register (PBWC) is clear. Clear the PLLF bit by reading the PLL control register. Reset clears the PLLF bit.

- 1 = Change in lock condition
- 0 = No change in lock condition

**NOTE:** Do not inadvertently clear the PLLF bit. Any read or read-modify-write operation on the PLL control register clears the PLLF bit.

### PLLON — PLL On Bit

This read/write bit activates the PLL and enables the VCO clock, CGMVCLK. PLLON cannot be cleared if the VCO clock is driving the base clock, CGMOUT (BCS = 1). (See [8.4.3 Base Clock Selector Circuit](#).) Reset sets this bit so that the loop can stabilize as the MCU is powering up.

1 = PLL on

0 = PLL off

### BCS — Base Clock Select Bit

This read/write bit selects either the crystal oscillator output, CGMXCLK, or the VCO clock, CGMVCLK, as the source of the CGM output, CGMOUT. CGMOUT frequency is one-half the frequency of the selected clock. BCS cannot be set while the PLLON bit is clear. After toggling BCS, it may take up to three CGMXCLK and three CGMVCLK cycles to complete the transition from one source clock to the other. During the transition, CGMOUT is held in stasis. (See [8.4.3 Base Clock Selector Circuit](#).) Reset clears the BCS bit.

1 = CGMVCLK divided by two drives CGMOUT.

0 = CGMXCLK divided by two drives CGMOUT.

**NOTE:** *PLLON and BCS have built-in protection that prevents the base clock selector circuit from selecting the VCO clock as the source of the base clock if the PLL is off. Therefore, PLLON cannot be cleared when BCS is set, and BCS cannot be set when PLLON is clear. If the PLL is off (PLLON = 0), selecting CGMVCLK requires two writes to the PLL control register. (See [8.4.3 Base Clock Selector Circuit](#).)*

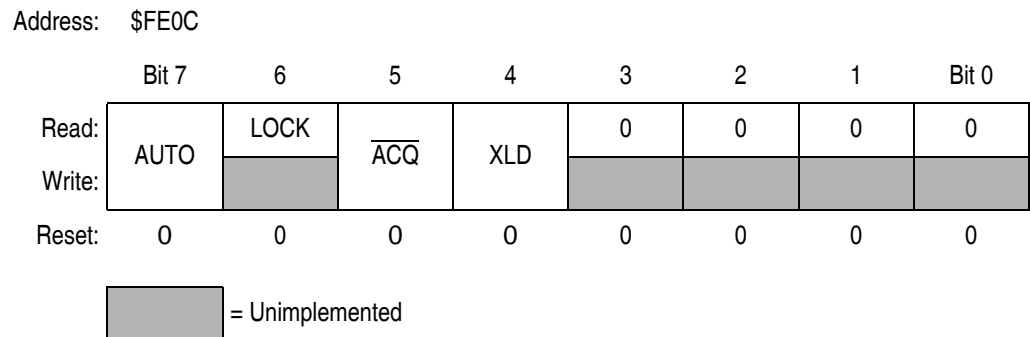
### PCTL[3:0] — Unimplemented bits

These bits provide no function and always read as logic 1s.

## 8.6.2 PLL Bandwidth Control Register

The PLL bandwidth control register does the following:

- Selects automatic or manual (software-controlled) bandwidth control mode
- Indicates when the PLL is locked
- In automatic bandwidth control mode, indicates when the PLL is in acquisition or tracking mode
- In manual operation, forces the PLL into acquisition or tracking mode.



**Figure 8-6. PLL Bandwidth Control Register (PBWC)**

### AUTO — Automatic Bandwidth Control Bit

This read/write bit selects automatic or manual bandwidth control. When initializing the PLL for manual operation (AUTO = 0), clear the  $\overline{ACQ}$  bit before turning on the PLL. Reset clears the AUTO bit.

1 = Automatic bandwidth control

0 = Manual bandwidth control

### LOCK — Lock Indicator Bit

When the AUTO bit is set, LOCK is a read-only bit that becomes set when the VCO clock, CGMVCLK, is locked (running at the programmed frequency). When the AUTO bit is clear, LOCK reads as logic 0 and has no meaning. Reset clears the LOCK bit.

1 = VCO frequency correct or locked

0 = VCO frequency incorrect or unlocked

### $\overline{ACQ}$ — Acquisition Mode Bit

When the AUTO bit is set,  $\overline{ACQ}$  is a read-only bit that indicates whether the PLL is in acquisition mode or tracking mode. When the AUTO bit is clear,  $\overline{ACQ}$  is a read/write bit that controls whether the PLL is in acquisition or tracking mode.

In automatic bandwidth control mode (AUTO = 1), the last-written value from manual operation is stored in a temporary location and is recovered when manual operation resumes. Reset clears this bit, enabling acquisition mode.

- 1 = Tracking mode
- 0 = Acquisition mode

### XLD — Crystal Loss Detect Bit

When the VCO output, CGMVCLK, is driving CGMOUT, this read/write bit can indicate whether the crystal reference frequency is active or not. To check the status of the crystal reference, do the following:

1. Write a logic 1 to XLD.
2. Wait  $N \times 4$  cycles. (N is the VCO frequency multiplier.)
3. Read XLD.
  - 1 = Crystal reference is not active
  - 0 = Crystal reference is active

The crystal loss detect function works only when the BCS bit is set, selecting CGMVCLK to drive CGMOUT. When BCS is clear, XLD always reads as logic 0.

### PBWC[3:0] — Reserved for Test

These bits enable test functions not available in user mode. To ensure software portability from development systems to user applications, software should write zeros to PBWC[3:0] whenever writing to PBWC.



### 8.6.3 PLL Programming Register

The PLL programming register contains the programming information for the modulo feedback divider and the programming information for the hardware configuration of the VCO.

Address: \$FE0D

	Bit 7	6	5	4	3	2	1	Bit 0
Read:	MUL7	MUL6	MUL5	MUL4	VRS7	VRS6	VRS5	VRS4
Write:								
Reset:	0	1	1	0	0	1	1	0

**Figure 8-7. PLL Programming Register (PPG)**

#### MUL[7:4] — Multiplier Select Bits

These read/write bits control the modulo feedback divider that selects the VCO frequency multiplier, N. (See [8.4.2.1 PLL Circuits](#) and [8.4.2.4 Programming the PLL](#).) A value of \$0 in the multiplier select bits configures the modulo feedback divider the same as a value of \$1. Reset initializes these bits to \$6 to give a default multiply value of 6.

**Table 8-1. VCO Frequency Multiplier (N) Selection**

MUL7:MUL6:MUL5:MUL4	VCO Frequency Multiplier (N)
0000	1
0001	1
0010	2
0011	3
↓	↓
1101	13
1110	14
1111	15

**NOTE:** *The multiplier select bits have built-in protection that prevents them from being written when the PLL is on (PLLON = 1).*

#### VRS[7:4] — VCO Range Select Bits

These read/write bits control the hardware center-of-range linear multiplier L, which controls the hardware center-of-range frequency  $f_{VRS}$ . (See [8.4.2.1 PLL Circuits](#), [8.4.2.4 Programming the PLL](#), and [8.6.1 PLL Control Register](#).) VRS[7:4] cannot be written when the PLLON bit in the PLL control register (PCTL) is set. (See [8.4.2.5 Special Programming Exceptions](#).) A value of \$0 in the VCO range select bits disables the PLL and clears the BCS bit in the PCTL. (See [8.4.3 Base Clock Selector Circuit](#) and [8.4.2.5 Special Programming Exceptions](#) for more information.) Reset initializes the bits to \$6 to give a default range multiply value of 6.

**NOTE:** *The VCO range select bits have built-in protection that prevents them from being written when the PLL is on (PLLON = 1) and prevents selection of the VCO clock as the source of the base clock (BCS = 1) if the VCO range select bits are all clear.*

*The VCO range select bits must be programmed correctly. Incorrect programming may result in failure of the PLL to achieve lock.*

## 8.7 Interrupts

When the AUTO bit is set in the PLL bandwidth control register (PBWC), the PLL can generate a CPU interrupt request every time the LOCK bit changes state. The PLLIE bit in the PLL control register (PCTL) enables CPU interrupts from the PLL. PLLF, the interrupt flag in the PCTL, becomes set whether interrupts are enabled or not. When the AUTO bit is clear, CPU interrupts from the PLL are disabled and PLLF reads as logic 0.

Software should read the LOCK bit after a PLL interrupt request to see if the request was due to an entry into lock or an exit from lock. When the PLL enters lock, the VCO clock, CGMVCLK, divided by two can be selected as the CGMOUT source by setting BCS in the PCTL. When the PLL exits lock, the VCO clock frequency is corrupt, and appropriate precautions should be taken. If the application is not frequency-sensitive, interrupts should be disabled to prevent PLL interrupt service routines from impeding software performance or from exceeding stack limitations.

**NOTE:** *Software can select the CGMVCLK divided by two as the CGMOUT source even if the PLL is not locked (LOCK = 0). Therefore, software should make sure the PLL is locked before setting the BCS bit.*

## 8.8 Wait Mode

The WAIT instruction puts the MCU in low-power-consumption standby mode.

The WAIT instruction does not affect the CGM. Before entering wait mode, software can disengage and turn off the PLL by clearing the BCS and PLLON bits in the PLL control register (PCTL). Less power-sensitive applications can disengage the PLL without turning it off. Applications that require the PLL to wake the MCU from wait mode also can deselect the PLL output without turning off the PLL.

### 8.9 CGM During Break Mode

The system integration module (SIM) controls whether status bits in other modules can be cleared during the break state. The BCFE bit in the SIM break flag control register (SBFCR) enables software to clear status bits during the break state. (See [7.7.4 SIM Break Flag Control Register](#).)

To allow software to clear status bits during a break interrupt, write a logic 1 to the BCFE bit. If a status bit is cleared during the break state, it remains cleared when the MCU exits the break state.

To protect the PLLF bit during the break state, write a logic 0 to the BCFE bit. With BCFE at logic 0 (its default state), software can read and write the PLL control register during the break state without affecting the PLLF bit.

### 8.10 Acquisition/Lock Time Specifications

The acquisition and lock times of the PLL are, in many applications, the most critical PLL design parameters. Proper design and use of the PLL ensures the highest stability and lowest acquisition/lock times.

#### 8.10.1 Acquisition/Lock Time Definitions

Typical control systems refer to the acquisition time or lock time as the reaction time, within specified tolerances, of the system to a step input. In a PLL, the step input occurs when the PLL is turned on or when it suffers a noise hit. The tolerance is usually specified as a percent of the step input or when the output settles to the desired value plus or minus a percent of the frequency change. Therefore, the reaction time is constant in this definition, regardless of the size of the step input. For example, consider a system with a 5% acquisition time tolerance. If a command instructs the system to change from 0 Hz to 1 MHz, the acquisition time is the time taken for the frequency to reach 1 MHz  $\pm$ 50 kHz. Fifty kHz = 5% of the 1-MHz step input. If the system is operating at 1 MHz and suffers a –100-kHz noise hit, the acquisition time

is the time taken to return from 900 kHz to 1 MHz  $\pm 5$  kHz. Five kHz = 5% of the 100-kHz step input.

Other systems refer to acquisition and lock times as the time the system takes to reduce the error between the actual output and the desired output to within specified tolerances. Therefore, the acquisition or lock time varies according to the original error in the output. Minor errors may not even be registered. Typical PLL applications prefer to use this definition because the system requires the output frequency to be within a certain tolerance of the desired frequency regardless of the size of the initial error.

The discrepancy in these definitions makes it difficult to specify an acquisition or lock time for a typical PLL. Therefore, the definitions for acquisition and lock times for this module are as follows:

- Acquisition time,  $t_{ACQ}$ , is the time the PLL takes to reduce the error between the actual output frequency and the desired output frequency to less than the tracking mode entry tolerance,  $\Delta_{TRK}$ . Acquisition time is based on an initial frequency error,  $(f_{DES} - f_{ORIG})/f_{DES}$ , of not more than  $\pm 100\%$ . In automatic bandwidth control mode (see [8.4.2.3 Manual and Automatic PLL Bandwidth Modes](#)), acquisition time expires when the  $\overline{ACQ}$  bit becomes set in the PLL bandwidth control register (PBWC).
- Lock time,  $t_{LOCK}$ , is the time the PLL takes to reduce the error between the actual output frequency and the desired output frequency to less than the lock mode entry tolerance,  $\Delta_{LOCK}$ . Lock time is based on an initial frequency error,  $(f_{DES} - f_{ORIG})/f_{DES}$ , of not more than  $\pm 100\%$ . In automatic bandwidth control mode, lock time expires when the LOCK bit becomes set in the PLL bandwidth control register (PBWC). (See [8.4.2.3 Manual and Automatic PLL Bandwidth Modes](#).)

Obviously, the acquisition and lock times can vary according to how large the frequency error is and may be shorter or longer in many cases.

### 8.10.2 Parametric Influences on Reaction Time

Acquisition and lock times are designed to be as short as possible while still providing the highest possible stability. These reaction times are not constant, however. Many factors directly and indirectly affect the acquisition time.

The most critical parameter which affects the reaction times of the PLL is the reference frequency,  $f_{RDV}$ . This frequency is the input to the phase detector and controls how often the PLL makes corrections. For stability, the corrections must be small compared to the desired frequency, so several corrections are required to reduce the frequency error. Therefore, the slower the reference the longer it takes to make these corrections. This parameter is also under user control via the choice of crystal frequency,  $f_{XCLK}$ .

Another critical parameter is the external filter capacitor. The PLL modifies the voltage on the VCO by adding or subtracting charge from this capacitor. Therefore, the rate at which the voltage changes for a given frequency error (thus change in charge) is proportional to the capacitor size. The size of the capacitor also is related to the stability of the PLL. If the capacitor is too small, the PLL cannot make small enough adjustments to the voltage and the system cannot lock. If the capacitor is too large, the PLL may not be able to adjust the voltage in a reasonable time. (See [8.10.3 Choosing a Filter Capacitor](#).)

Also important is the operating voltage potential applied to  $V_{DDA}$ . The power supply potential alters the characteristics of the PLL. A fixed value is best. Variable supplies, such as batteries, are acceptable if they vary within a known range at very slow speeds. Noise on the power supply is not acceptable, because it causes small frequency errors which continually change the acquisition time of the PLL.

Temperature and processing also can affect acquisition time because the electrical characteristics of the PLL change. The part operates as specified as long as these influences stay within the specified limits. External factors, however, can cause drastic changes in the operation of the PLL. These factors include noise injected into the PLL through the filter capacitor, filter capacitor leakage, stray impedances on the circuit board, and even humidity or circuit board contamination.

### 8.10.3 Choosing a Filter Capacitor

As described in [8.10.2 Parametric Influences on Reaction Time](#), the external filter capacitor,  $C_F$ , is critical to the stability and reaction time of the PLL. The PLL is also dependent on reference frequency and supply voltage. The value of the capacitor must, therefore, be chosen with supply potential and reference frequency in mind. For proper operation, the external filter capacitor must be chosen according to the following equation:

$$C_F = C_{\text{FACT}} \left( \frac{V_{\text{DDA}}}{f_{\text{RDV}}} \right)$$

For acceptable values of  $C_{\text{FACT}}$ , see [Table 21-10. CGM Acquisition/Lock Time Specifications](#). For the value of  $V_{\text{DDA}}$ , choose the voltage potential at which the MCU is operating. If the power supply is variable, choose a value near the middle of the range of possible supply values.

This equation does not always yield a commonly available capacitor size, so round to the nearest available size. If the value is between two different sizes, choose the higher value for better stability. Choosing the lower size may seem attractive for acquisition time improvement, but the PLL can become unstable. Also, always choose a capacitor with a tight tolerance ( $\pm 20\%$  or better) and low dissipation.

### 8.10.4 Reaction Time Calculation

The actual acquisition and lock times can be calculated using the equations below. These equations yield nominal values under the following conditions:

- Correct selection of filter capacitor,  $C_F$  (See [8.10.3 Choosing a Filter Capacitor](#).)
- Room temperature operation
- Negligible external leakage on CGMXFC
- Negligible noise

The K factor in the equations is derived from internal PLL parameters.  $K_{ACQ}$  is the K factor when the PLL is configured in acquisition mode, and  $K_{TRK}$  is the K factor when the PLL is configured in tracking mode. (See [8.4.2.2 Acquisition and Tracking Modes](#).)

$$t_{ACQ} = \left( \frac{V_{DDA}}{f_{RDV}} \right) \left( \frac{8}{K_{ACQ}} \right)$$

$$t_{AL} = \left( \frac{V_{DDA}}{f_{RDV}} \right) \left( \frac{4}{K_{TRK}} \right)$$

$$t_{LOCK} = t_{ACQ} + t_{AL}$$

Note the inverse proportionality between the lock time and the reference frequency.

In automatic bandwidth control mode, the acquisition and lock times are quantized into units based on the reference frequency. (See [8.4.2.3 Manual and Automatic PLL Bandwidth Modes](#).) A certain number of clock cycles,  $n_{ACQ}$ , is required to ascertain that the PLL is within the tracking mode entry tolerance,  $\Delta_{TRK}$ , before exiting acquisition mode. A certain number of clock cycles,  $n_{TRK}$ , is required to ascertain that the PLL is within the lock mode entry tolerance,  $\Delta_{LOCK}$ . Therefore, the acquisition time,  $t_{ACQ}$ , is an integer multiple of  $n_{ACQ}/f_{RDV}$ , and the acquisition to lock time,  $t_{AL}$ , is an integer multiple of  $n_{TRK}/f_{RDV}$ . Also, since the average frequency over the entire measurement period must be within the specified tolerance, the total time usually is longer than  $t_{LOCK}$  as calculated above.

In manual mode, it is usually necessary to wait considerably longer than  $t_{LOCK}$  before selecting the PLL clock (see [8.4.3 Base Clock Selector Circuit](#)) because the factors described in [8.10.2 Parametric Influences on Reaction Time](#) may slow the lock time considerably.



## Section 9. Pulse Width Modulator for Motor Control (PWMMC)

### 9.1 Contents

9.2	Introduction . . . . .	130
9.3	Features . . . . .	131
9.4	Timebase . . . . .	135
9.4.1	Resolution . . . . .	135
9.4.2	Prescaler . . . . .	137
9.5	PWM Generators . . . . .	137
9.5.1	Load Operation . . . . .	137
9.5.2	PWM Data Overflow and Underflow Conditions . . . . .	142
9.6	Output Control . . . . .	142
9.6.1	Selecting Six Independent PWMs or Three Complementary PWM Pairs . . . . .	142
9.6.2	Dead-Time Insertion . . . . .	144
9.6.3	Top/Bottom Correction . . . . .	149
9.6.3.1	Manual Correction . . . . .	152
9.6.3.2	Automatic Correction . . . . .	154
9.6.4	Output Polarity . . . . .	156
9.6.5	Output Port Control . . . . .	158
9.7	Fault Protection . . . . .	159
9.7.1	Fault Condition Input Pins . . . . .	164
9.7.1.1	Fault Pin Filter . . . . .	165
9.7.1.2	Automatic Mode . . . . .	165
9.7.1.3	Manual Mode . . . . .	166
9.7.2	Software Output Disable . . . . .	168
9.7.3	Output Port Control . . . . .	168
9.8	Initialization and the PWMEN Bit . . . . .	169
9.9	PWM Operation in Wait Mode . . . . .	171
9.10	PWM Operation in Break Mode . . . . .	171

9.11	Control Logic Block . . . . .	172
9.11.1	PWM Counter Registers . . . . .	172
9.11.2	PWM Counter Modulo Registers . . . . .	173
9.11.3	PWM X Value Registers . . . . .	174
9.11.4	PWM Control Register 1 . . . . .	175
9.11.5	PWM Control Register 2 . . . . .	177
9.11.6	Dead-Time Write-Once Register . . . . .	179
9.11.7	PWM Disable Mapping Write-Once Register . . . . .	180
9.11.8	Fault Control Register . . . . .	180
9.11.9	Fault Status Register . . . . .	183
9.11.10	Fault Acknowledge Register . . . . .	185
9.11.11	PWM Output Control Register . . . . .	186
9.12	PWM Glossary . . . . .	188

## 9.2 Introduction

This section describes the pulse width modulator for motor control (PWMMC, Version A). The MC68HC(7)08MP16 PWM module can generate three complementary PWM pairs or six independent PWM signals. These PWM signals can be center-aligned or edge-aligned. A block diagram of the PWM module is shown in [Figure 9-1](#).

A 12-bit timer PWM counter is common to all six channels. PWM resolution is one clock period for edge-aligned operation and two clock periods for center-aligned operation. The clock period is dependent on the internal operating frequency ( $f_{op}$ ) and a programmable prescaler. The highest resolution for edge-aligned operation is 125 ns ( $f_{op} = 8$  MHz). The highest resolution for center-aligned operation is 250 ns ( $f_{op} = 8$  MHz).

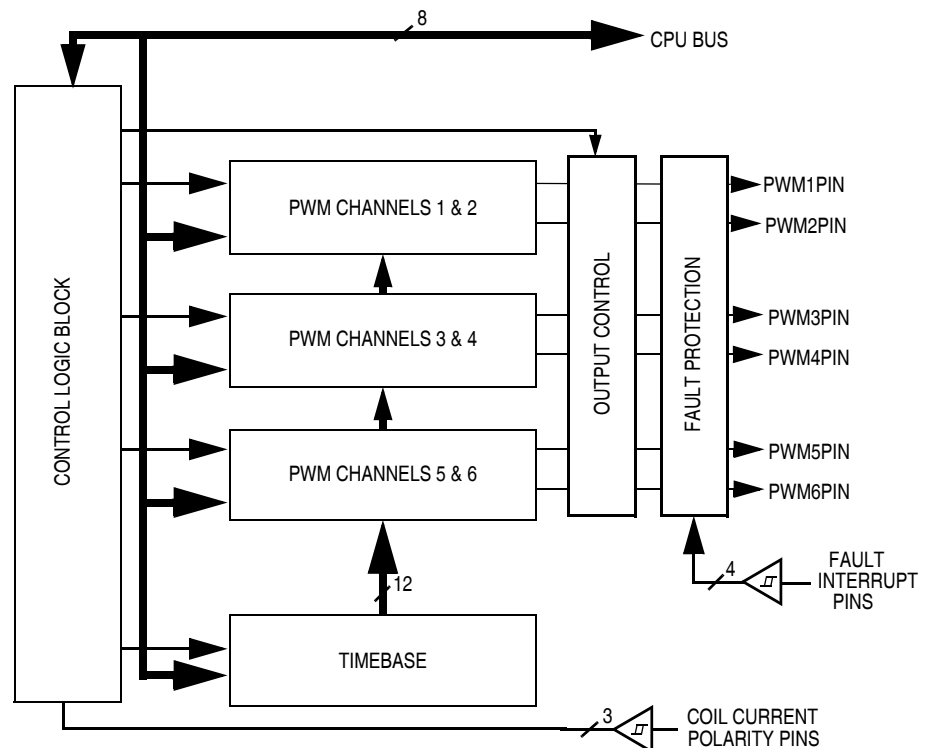
When generating complementary PWM signals, the module features automatic dead-time insertion to the PWM output pairs and transparent toggling of PWM data based upon sensed motor phase current polarity.

A summary of the PWM registers is shown in [Figure 9-2](#).

## 9.3 Features

Features of the PWMMC include the following:

- Three complimentary PWM pairs or six independent PWM signals
- Edge-aligned PWM signals or center-aligned PWM signals
- PWM signal polarity control
- 20 mA current sink capability on PWM pins
- Manual PWM output control through software
- Programmable fault protection
- Complimentary mode also features:
  - Dead-time insertion
  - Separate top/bottom pulse width correction via current sensing or programmable software bits



**Figure 9-1. PWM Module Block Diagram**

# Pulse Width Modulator for Motor Control (PWMMC)


Addr.	Name	Bit 7	6	5	4	3	2	1	Bit 0	
\$0020	PWM Control Register 1 (PCTL1)	Read:	DISX	DISY	PWMINT	PWMF	ISENS1	ISENS0	LDOK	PWMEN
		Write:								
		Reset:	0	0	0	0	0	0	0	0
\$0021	PWM Control Register 2 (PCTL2)	Read:	LDFQ1	LDFQ0	0	IPOL1	IPOL2	IPOL3	PRSC1	PRSC0
		Write:								
		Reset:	0	0	0	0	0	0	0	0
\$0022	Fault Control Register (FCR)	Read:	FINT4	FMODE4	FINT3	FMODE3	FINT2	FMODE2	FINT1	FMODE1
		Write:								
		Reset:	0	0	0	0	0	0	0	0
\$0023	Fault Status Register (FSR)	Read:	FPIN4	FFLAG4	FPIN3	FFLAG3	FPIN2	FFLAG2	FPIN1	FFLAG1
		Write:								
		Reset:	U	0	U	0	U	0	U	0
\$0024	Fault Acknowledge Register (FTACK)	Read:	0	0	0	0	0	0	0	0
		Write:		FTACK4		FTACK3		FTACK2		FTACK1
		Reset:	0	0	0	0	0	0	0	0
\$0025	PWM Output Control (PWMOUT)	Read:	0	OUTCTL	OUT6	OUT5	OUT4	OUT3	OUT2	OUT1
		Write:								
		Reset:	0	0	0	0	0	0	0	0
\$0026	PWM Counter Register High (PCNTH)	Read:	0	0	0	0	11	10	9	Bit 8
		Write:								
		Reset:	0	0	0	0	0	0	0	0
\$0027	PWM Counter Register Low (PCNTL)	Read:	Bit 7	6	5	4	3	2	1	Bit 0
		Write:								
		Reset:	0	0	0	0	0	0	0	0
\$0028	PWM Counter Modulo Register High (PMODH)	Read:	0	0	0	0	11	10	9	Bit 8
		Write:								
		Reset:	0	0	0	0	X	X	X	X

X = Indeterminate    U = Unaffected     = Unimplemented

**Figure 9-2. PWMMC Register Summary**

Pulse Width Modulator for Motor Control (PWMMC)

Addr.	Name	Bit 7	6	5	4	3	2	1	Bit 0	
\$0029	PWM Counter Modulo Register Low (PMDL)	Read:	Bit 7	6	5	4	3	2	1	Bit 0
		Write:								
		Reset:	X	X	X	X	X	X	X	X
\$002A	PWM 1 Value Register High (PVAL1H)	Read:	Bit 15	14	13	12	11	10	9	Bit 8
		Write:								
		Reset:	0	0	0	0	0	0	0	0
\$002B	PWM 1 Value Register Low (PVAL1L)	Read:	Bit 7	6	5	4	3	2	1	Bit 0
		Write:								
		Reset:	0	0	0	0	0	0	0	0
\$002C	PWM 2 Value Register High (PVAL2H)	Read:	Bit 15	14	13	12	11	10	9	Bit 8
		Write:								
		Reset:	0	0	0	0	0	0	0	0
\$002D	PWM 2 Value Register Low (PVAL2L)	Read:	Bit 7	6	5	4	3	2	1	Bit 0
		Write:								
		Reset:	0	0	0	0	0	0	0	0
\$002E	PWM 3 Value Register High (PVAL3H)	Read:	Bit 15	14	13	12	11	10	9	Bit 8
		Write:								
		Reset:	0	0	0	0	0	0	0	0
\$002F	PWM 3 Value Register Low (PVAL3L)	Read:	Bit 7	6	5	4	3	2	1	Bit 0
		Write:								
		Reset:	0	0	0	0	0	0	0	0
\$0030	PWM 4 Value Register High (PVAL4H)	Read:	Bit 15	14	13	12	11	10	9	Bit 8
		Write:								
		Reset:	0	0	0	0	0	0	0	0
\$0031	PWM 4 Value Register Low (PVAL4L)	Read:	Bit 7	6	5	4	3	2	1	Bit 0
		Write:								
		Reset:	0	0	0	0	0	0	0	0

X = Indeterminate    U = Unaffected     = Unimplemented

**Figure 9-2. PWMMC Register Summary**

# Pulse Width Modulator for Motor Control (PWMMC)

Addr.	Name	Bit 7	6	5	4	3	2	1	Bit 0	
\$0032	PWM 5 Value Register High (PVAL5H)	Read:	Bit 15	14	13	12	11	10	9	Bit 8
		Write:								
		Reset:	0	0	0	0	0	0	0	0
\$0033	PWM 5 Value Register Low (PVAL5L)	Read:	Bit 7	6	5	4	3	2	1	Bit 0
		Write:								
		Reset:	0	0	0	0	0	0	0	0
\$0034	PWM 6 Value Register High (PVAL6H)	Read:	Bit 15	14	13	12	11	10	9	Bit 8
		Write:								
		Reset:	0	0	0	0	0	0	0	0
\$0035	PWM 6 Value Register Low (PVAL6L)	Read:	Bit 7	6	5	4	3	2	1	Bit 0
		Write:								
		Reset:	0	0	0	0	0	0	0	0
\$0036	Dead Timer Write-Once Register (DEADTM)	Read:	Bit 7	6	5	4	3	2	1	Bit 0
		Write:								
		Reset:	1	1	1	1	1	1	1	1
\$0037	PWM Disable Mapping Write-Once Register (DISMAP)	Read:	Bit 7	6	5	4	3	2	1	Bit 0
		Write:								
		Reset:	1	1	1	1	1	1	1	1

X = Indeterminate    U = Unaffected     = Unimplemented

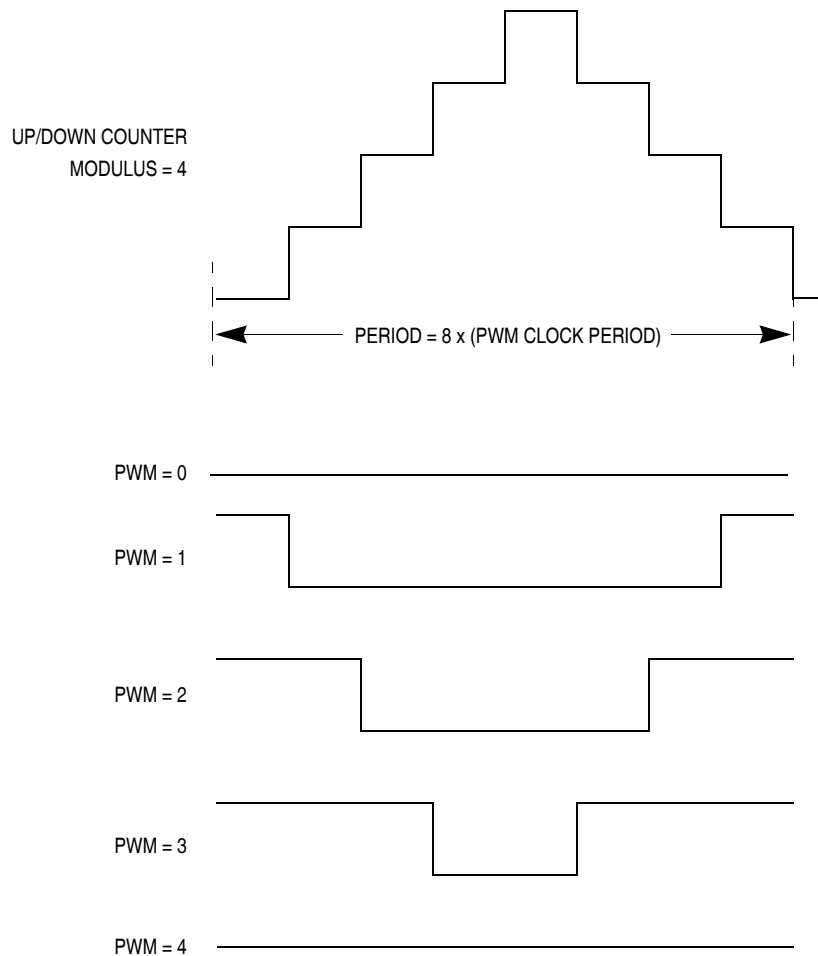
**Figure 9-2. PWMMC Register Summary**

## 9.4 Timebase

Refer to the following subsections for a discussion of the timebase.

### 9.4.1 Resolution

In center-aligned mode, a 12-bit up/down counter is used to create the PWM period. Therefore, the PWM resolution in center-aligned mode is two clocks (highest resolution is 250 ns @  $f_{op} = 8$  MHz) as shown in [Figure 9-3](#). The up/down counter uses the value in the timer modulus register to determine its maximum count. The PWM period will equal:  $[(\text{timer modulus}) \times (\text{PWM clock period}) \times 2]$ .

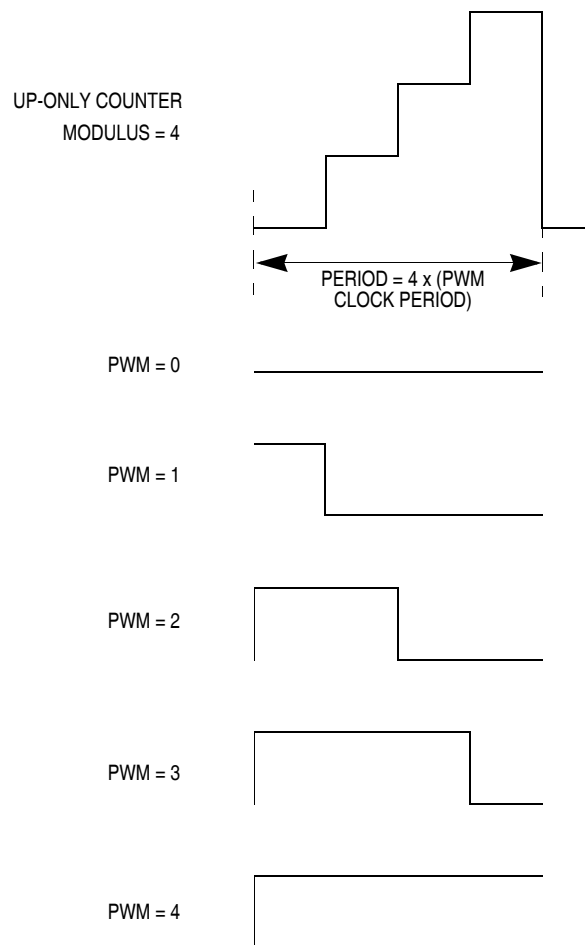


**Figure 9-3. Center-Aligned PWM (Positive Polarity)**

## Pulse Width Modulator for Motor Control (PWMMC)

For edge-aligned mode, a 12-bit up-only counter is used to create the PWM period. Therefore, the PWM resolution in edge-aligned mode is one clock (highest resolution is 125 ns @  $f_{op} = 8$  MHz) as shown in [Figure 9-4](#). Again, the timer modulus register is used to determine the maximum count. The PWM period will equal: [(timer modulus) x (PWM clock period)].

Center-aligned operation versus edge-aligned operation is determined by the option EDGE. See [5.3 Functional Description](#).



**Figure 9-4. Edge-Aligned PWM (Positive Polarity)**



## 9.4.2 Prescaler

To permit lower PWM frequencies, a prescaler is provided which will divide the PWM clock frequency by 1, 2, 4, or 8. [Table 9-1](#) shows how setting the prescaler bits in PWM control register 2 affects the PWM clock frequency. This prescaler is buffered and will not be used by the PWM generator until the LDOK bit is set and a new PWM reload-cycle begins.

**Table 9-1. PWM Prescaler**

Prescaler Bits PRSC1:PRSC0	PWM Clock Frequency
00	$f_{op}$
01	$f_{op}/2$
10	$f_{op}/4$
11	$f_{op}/8$

## 9.5 PWM Generators

Pulse width modulator (PWM) generators are discussed in the following subsections.

### 9.5.1 Load Operation

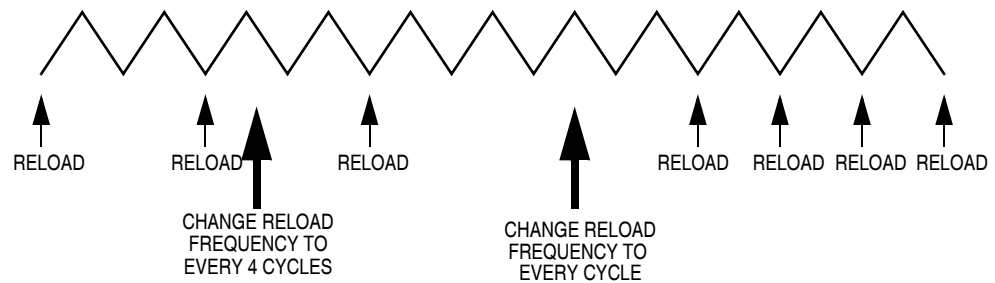
To help avoid erroneous pulse widths and PWM periods, the modulus, prescaler, and PWM value registers are buffered. New PWM values, counter modulus values, and prescalers can be loaded from their buffers into the PWM module every one, two, four, or eight PWM cycles. LDFQ1:LDFQ0 in PWM control register 2 are used to control this reload frequency, as shown in [Table 9-2](#). When a reload cycle arrives, regardless of whether an actual reload occurs (as determined by the LDOK bit), the PWM reload flag bit in PWM control register 1 will be set. If the PWMINT bit in PWM control register 1 is set, a CPU interrupt request will be generated when PWMF is set. Software can use this interrupt to calculate new PWM parameters in real time for the PWM module.

**Table 9-2. PWM Reload Frequency**

Reload Frequency Bits LDFQ1:LDFQ0	PWM Reload Frequency
00	Every PWM cycle
01	Every 2 PWM cycles
10	Every 4 PWM cycles
11	Every 8 PWM cycles

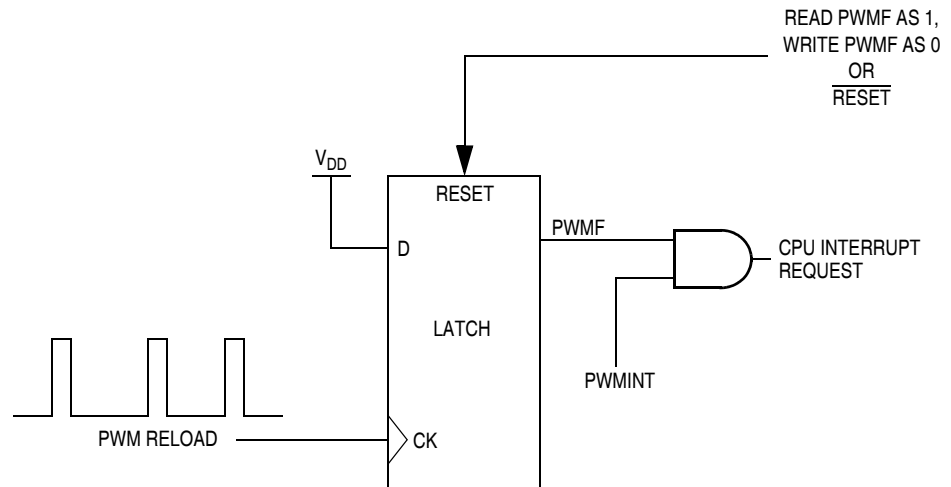
For ease of software, the LDFQx bits are buffered. When the LDFQx bits are changed, the reload frequency will not change until the previous reload cycle is completed. See [Figure 9-5](#).

**NOTE:** When reading the LDFQx bits, the value is the buffered value (for example, not necessarily the value being acted upon).



**Figure 9-5. Reload Frequency Change**

PWMINT enables CPU interrupt requests as shown in [Figure 9-6](#). When this bit is set, CPU interrupt requests are generated when the PWMF bit is set. When the PWMINT bit is clear, PWM interrupt requests are inhibited. PWM reloads will still occur at the reload rate, but no interrupt requests will be generated.

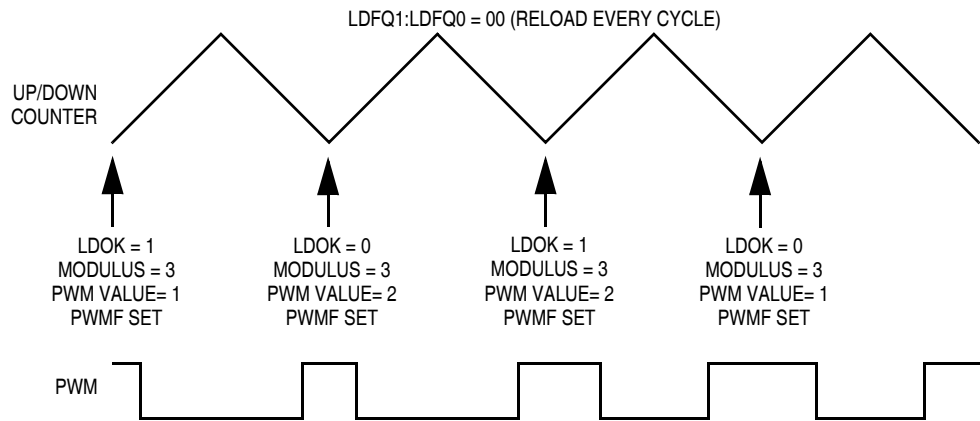


**Figure 9-6. PWM Interrupt Requests**

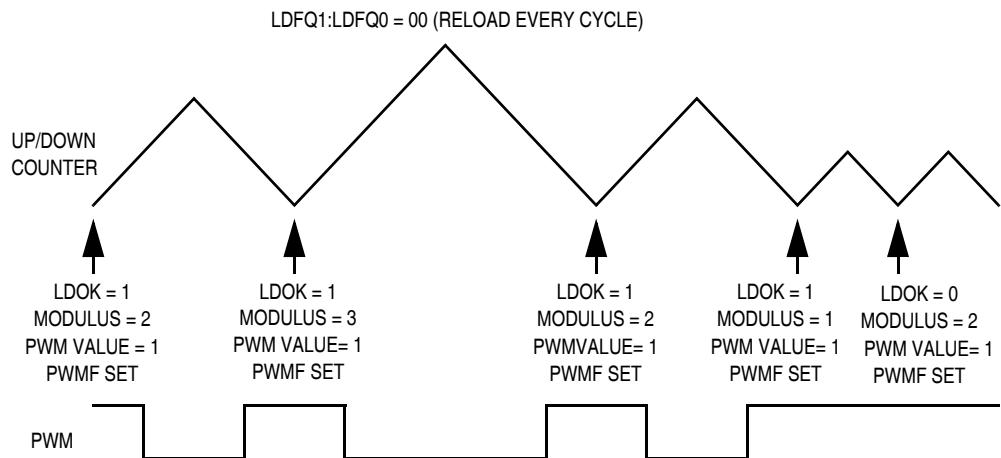
To prevent a partial reload of PWM parameters from occurring while the software is still calculating them, an interlock bit controlled from software is provided. This bit informs the PWM module that all the PWM parameters have been calculated, and it is “okay” to use them. A new modulus, prescaler, and/or PWM value cannot be loaded into the PWM module until the LDOK bit in PWM control register 1 is set. When the LDOK bit is set, these new values are loaded into a second set of registers and used by the PWM generator at the beginning of the next PWM reload cycle as shown in [Figure 9-7](#), [Figure 9-8](#), [Figure 9-9](#), and [Figure 9-10](#). After these values are loaded, the LDOK bit is cleared.

**NOTE:** *When the PWM module is enabled (via the PWMEN bit), a load will occur if the LDOK bit is set. Even if it is not set, an interrupt will occur if the PWMINT bit is set. To prevent this, the software should clear the PWMINT bit before enabling the PWM module.*

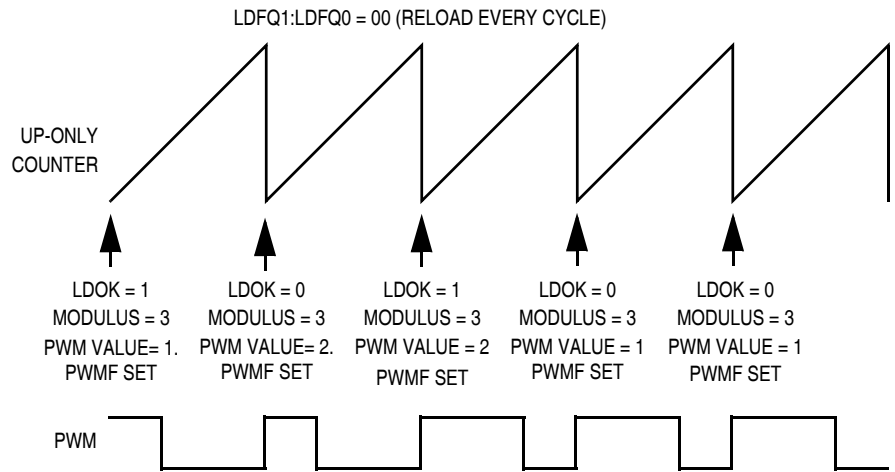
# Pulse Width Modulator for Motor Control (PWMMC)



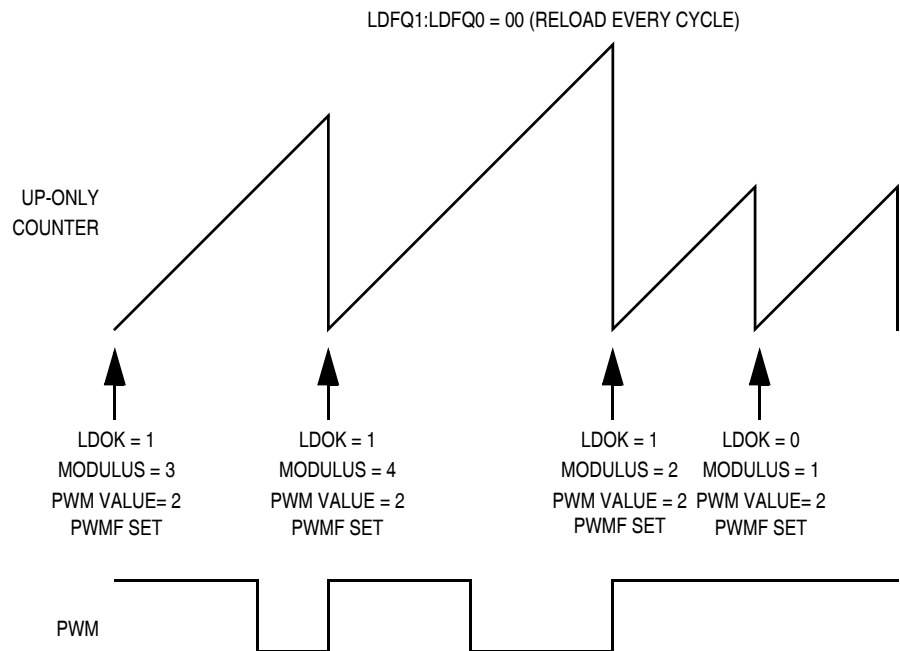
**Figure 9-7. Center-Aligned PWM Value Loading**



**Figure 9-8. Center-Aligned Loading of Modulus**



**Figure 9-9. Edge-Aligned PWM Value Loading**



**Figure 9-10. Edge-Aligned Modulus Loading**

## 9.5.2 PWM Data Overflow and Underflow Conditions

The PWM value registers are 16-bit registers. Although the counter is only 12 bits, the user may write a 16-bit signed value to a PWM value register. As shown in [Figure 9-3](#) and [Figure 9-4](#), if the PWM value is less than or equal to zero, the PWM will be inactive for the entire period. Conversely, if the PWM value is greater than or equal to the timer modulus, the PWM will be active for the entire period. Refer to [Table 9-3](#).

**NOTE:** *The terms “active” and “inactive” refer to the asserted and negated states of the PWM signals and should not be confused with the high impedance state of the PWM pins.*

**Table 9-3. PWM Data Overflow and Underflow Conditions**

PWMVALxH:PWMVALxL	Condition	PWM Value Used
\$0000 – \$0FFF	Normal	(Per Registers Contents)
\$1000 – \$7FFF	Overflow	\$FFF
\$8000 – \$FFFF	Underflow	\$000

## 9.6 Output Control

The following subsections discuss output control.

### 9.6.1 Selecting Six Independent PWMs or Three Complementary PWM Pairs

The PWM outputs can be configured as six independent PWM channels or three complementary channel pairs. The option INDEP determines which mode is used (see [5.3 Functional Description](#)). If complementary operation is chosen, the PWM pins are paired as shown in [Figure 9-11](#). Operation of one pair is then determined by one PWM value register. This type of operation is meant for use in motor drive circuits such as the one in [Figure 9-12](#).

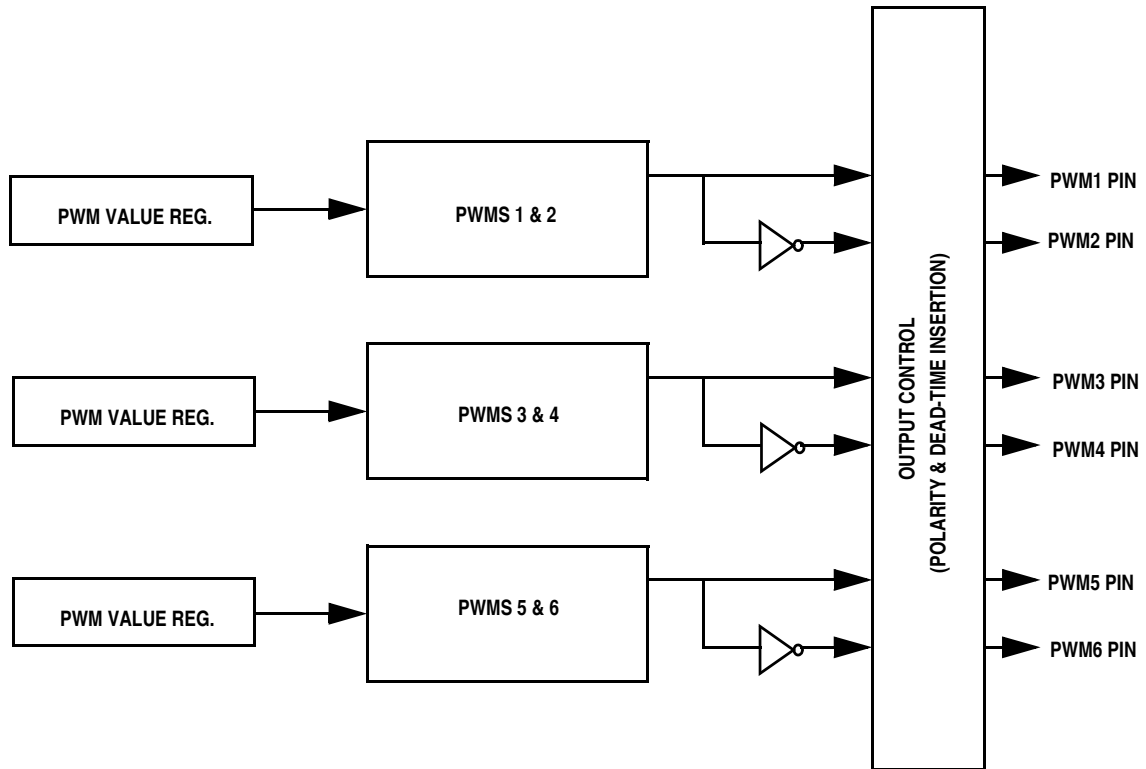


Figure 9-11. Complementary Pairing

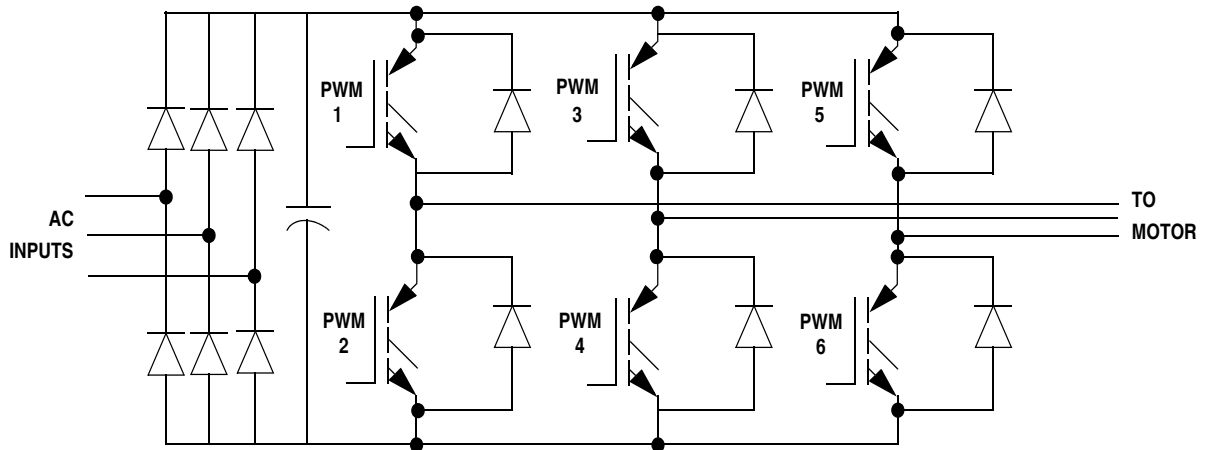


Figure 9-12. Typical AC Motor Drive

When complementary operation is used, two additional features are provided:

- Dead-time insertion
- Separate top/bottom pulse width correction to correct for distortions caused by the motor drive characteristics.

If independent operation is chosen, each PWM has its own PWM value register.

### 9.6.2 Dead-Time Insertion

As shown in [Figure 9-12](#), in complementary mode, each PWM pair can be used to drive top-side/bottom-side transistors.

When controlling DC-to-AC inverters such as this, the top and bottom PWMs in one pair should *never* be active at the same time. In [Figure 9-12](#), if PWM1 and PWM2 were on at the same time, large currents would flow through the two transistors as they discharge the bus capacitor. The IGBTs could be weakened or destroyed.

Simply forcing the two PWMs to be inversions of each other is not always sufficient. Since a time delay is associated with turning off the transistors in the motor drive, there must be a “dead-time” between the deactivation of one PWM and the activation of the other.

A dead-time can be specified in the dead-time write-once register. This 8-bit value specifies the number of CPU clock cycles to use for the dead-time. The dead-time is not affected by changes in the PWM period caused by the prescaler.

Dead-time insertion is achieved by feeding the top PWM outputs of the PWM generator into dead-time generators, as shown in [Figure 9-13](#). Current sensing determines which PWM value of a PWM generator pair to use for the TOP PWM in the next PWM cycle. (See [9.6.3 Top/Bottom Correction](#).) When output control is enabled, the odd OUT bits, rather than the PWM generator outputs, are fed into the dead-time generators. (See [9.6.5 Output Port Control](#).)



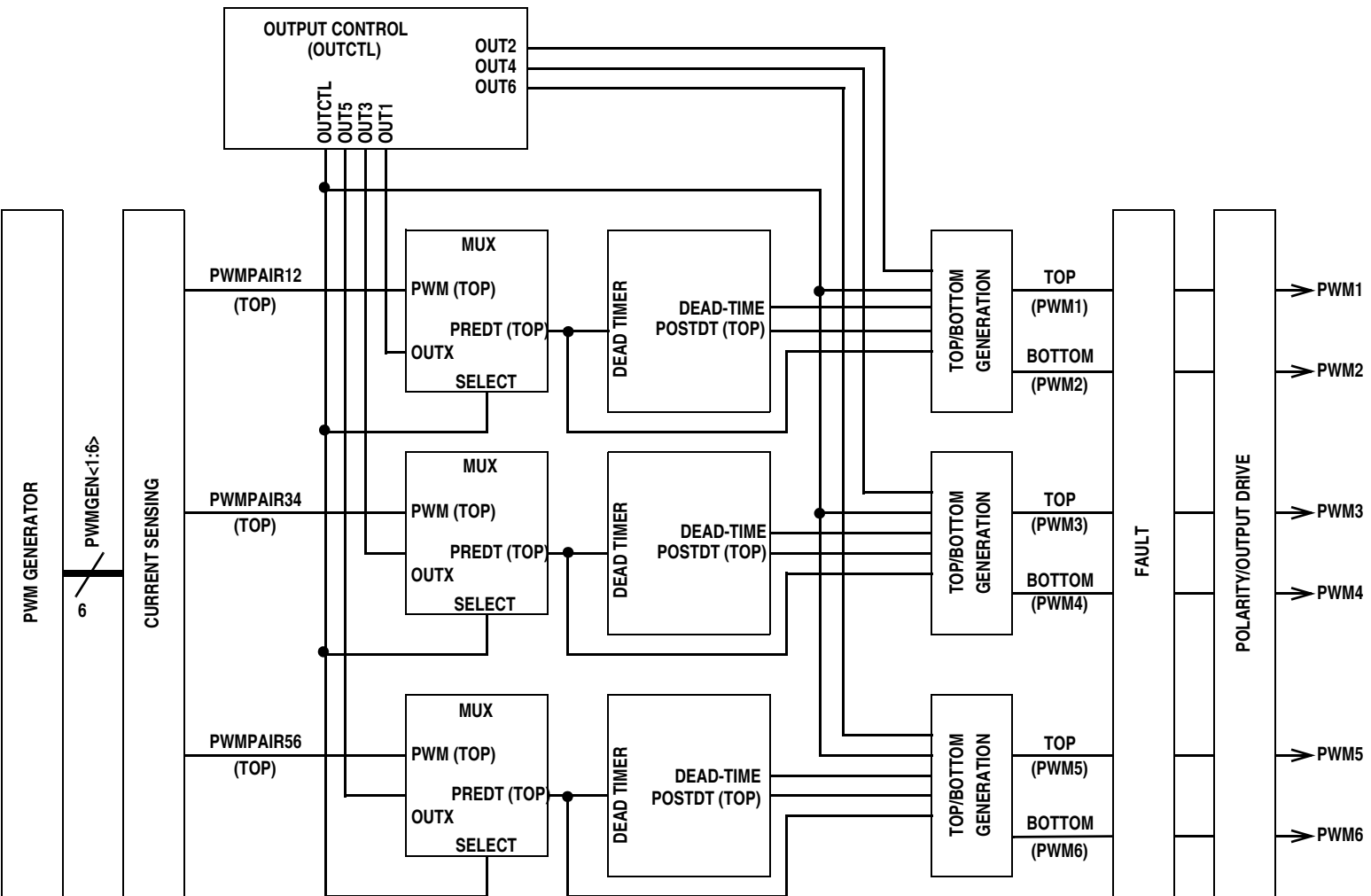


Figure 9-13. Dead-Time Generators

Whenever an input to a dead-time generator transitions, a dead-time is inserted (for example, both PWMs in the pair are forced to their inactive state). The BOTTOM PWM signal is generated from the TOP PWM and the dead-time. In the case of output control enabled, the odd OUTx bits control the top PWMs, the even OUTx bits control the bottom PWMs *with respect to the odd OUTx bits*. (See [Table 9-7](#).) [Figure 9-14](#) shows the effects of the dead-time insertion.

As seen in [Figure 9-14](#), some pulse width distortion occurs when the dead-time is inserted. The active pulse widths are reduced. For example, in [Figure 9-14](#), when the PWM value register is equal to two, the ideal waveform (with no dead-time) has pulse widths equal to four. However, the actual pulse widths shrink to two after a dead-time of two was inserted. In this example, with the prescaler set to divide by one and center-aligned operation selected, this distortion can be compensated for by adding or subtracting half the dead-time value to or from the PWM register value. This correction is further described in [9.6.3 Top/Bottom Correction](#).

Further examples of dead-time insertion are shown in [Figure 9-15](#) and [Figure 9-16](#). [Figure 9-15](#) shows the effects of dead-time insertion at the duty cycle boundaries (near 0% and 100% duty cycles). [Figure 9-16](#) shows the effects of dead-time insertion on pulse widths smaller than the dead-time.

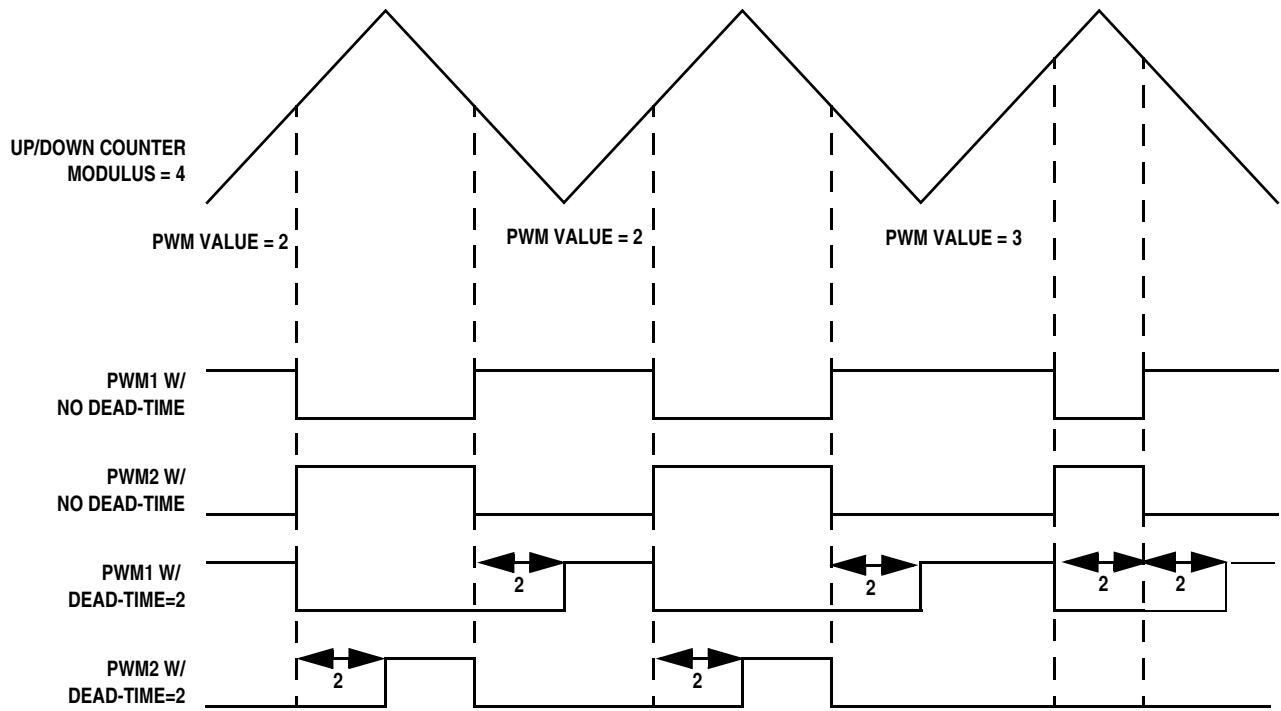


Figure 9-14. Effects of Dead-Time Insertion

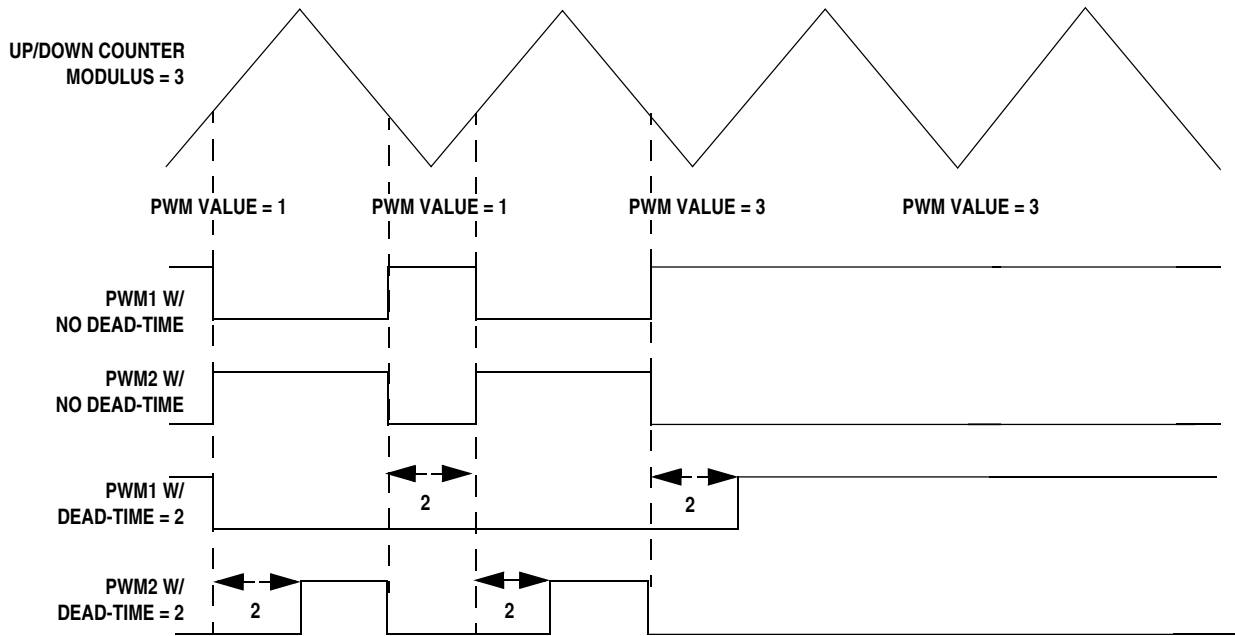


Figure 9-15. Dead-Time at Duty Cycle Boundaries

# Pulse Width Modulator for Motor Control (PWMMC)

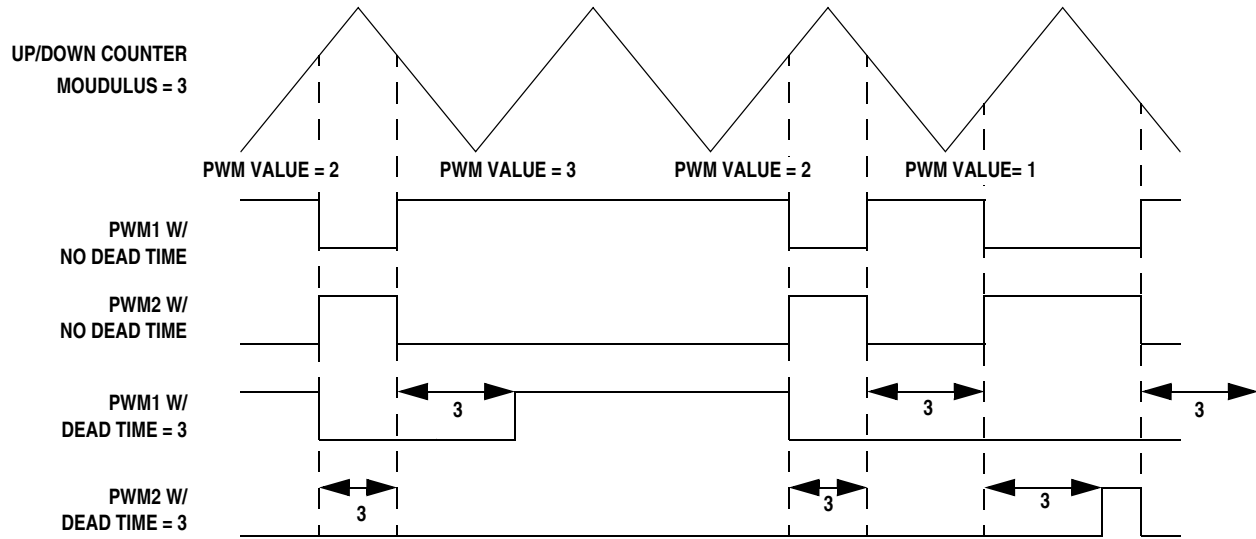
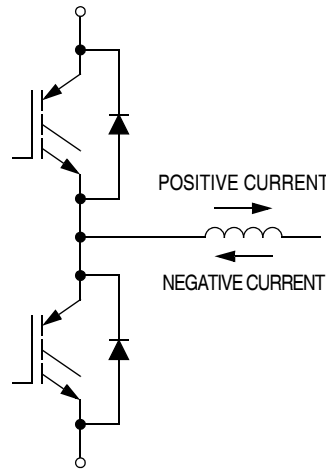


Figure 9-16. Dead-Time and Small Pulse Widths

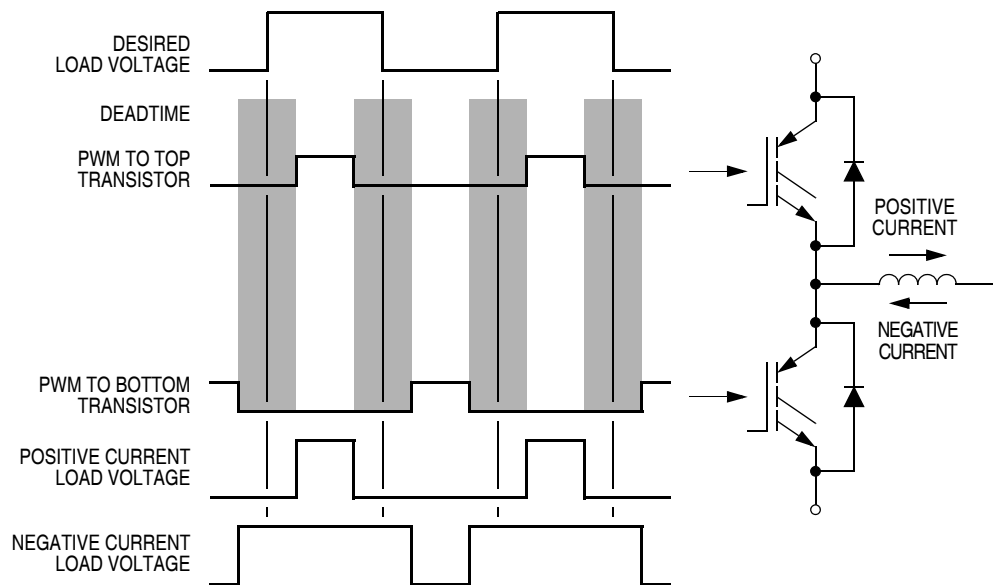
### 9.6.3 Top/Bottom Correction

In a half-bridge AC motor drive, either the top or the bottom transistor controls the output voltage at any given time. The direction of the motor current determines which transistor controls the output.



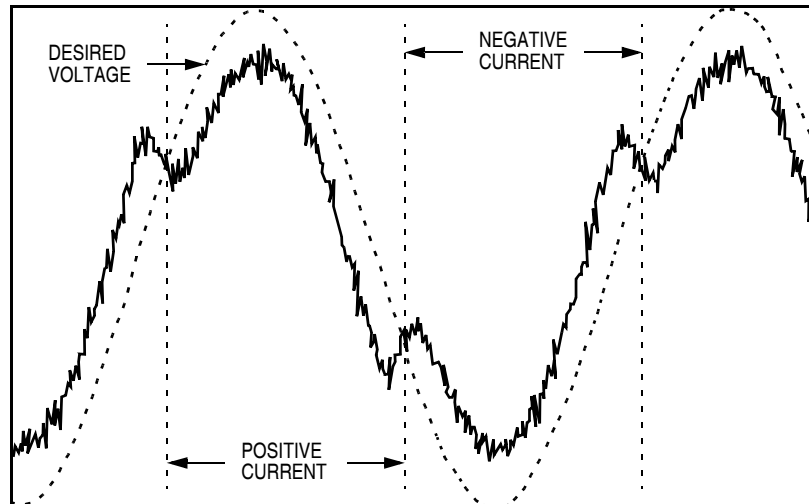
**Figure 9-17. Current Convention**

During deadtime, both transistors in a half-bridge are off, allowing the load voltage to float and introducing distortion in the output voltage.



**Figure 9-18. Deadtime Distortion**

During deadtime, load inductance distorts output voltage by keeping inductive current flowing through the diodes. Inductive distortion either lengthens or shortens the pulse width by one deadtime interval, depending on current direction. This deadtime distortion then either increases or decreases the averaged sinusoidal output voltage.



**Figure 9-19. Sinusoidal Distortion of Load Voltage**

In complementary channel operation, either the odd-numbered or the even-numbered PWMVAL registers control the pulse width at any given time. For a given PWM pair, whether the odd or even PWMVAL registers are active depends on either:

- The state of the current-sensing pin, ISx, for that driver, or
- The state of the output polarity bit, IPOLx, for that driver

To correct deadtime distortion, software can decrease or increase the value in the appropriate PWMVAL register.

- In edge-aligned operation, decreasing or increasing the PWM value by a correction value equal to the deadtime compensates for deadtime distortion.
- In center aligned operation, decreasing or increasing the PWM value by a correction value equal to one-half the deadtime compensates for deadtime distortion.

In complementary channel operation, the ISENS1–3 bits in PWM control register 1 select one of three correction methods:

- Manual correction
- Automatic current-sensing correction during deadtime
- Automatic current sensing correction when the PWM counter value equals the value in the PWM counter modulus registers.

**Table 9-4. Correction Method Selection**

ISENS[1:0]	Correction method
0X	Manual correction with IPOL1–IPOL3 bits; or for no correction
10	Automatic current-sensing correction on pins $\overline{IS1}$ , $\overline{IS2}$ , and $\overline{IS3}$ during deadtime <sup>(1)</sup>
11	Automatic current-sensing correction on pins $\overline{IS1}$ , $\overline{IS2}$ , and $\overline{IS3}$ <sup>(2)</sup> At the half cycle in center-aligned operation At the end of the cycle in edge-aligned operation

1. The polarity of the  $\overline{ISx}$  pin is latched when both the top and bottom PWMs are off. At the 0% and 100% duty cycle boundaries, there is no deadtime, so no new current value is sensed.

2. Current is sensed even with 0% or 100% duty cycle.

**NOTE:** *The ISENSx bits are not buffered; therefore, changing the current sensing method can affect the present PWM cycle.*

# Pulse Width Modulator for Motor Control (PWMMC)

## 9.6.3.1 Manual Correction

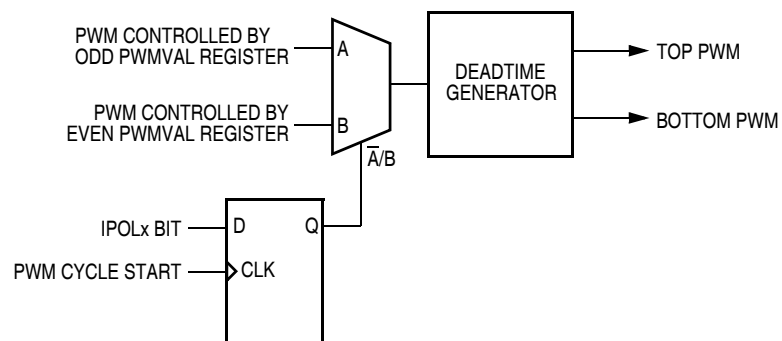
The IPOL1–IPOL3 bits select either the odd or the even PWM value registers to use in the next PWM cycle.

**Table 9-5. Top/Bottom Manual Correction**

Bit	Logic state	Output control
IPOL1	0	PMVAL1 controls PWM1/PWM2 pair
	1	PMVAL2 controls PWM1/PWM2 pair
IPOL2	0	PMVAL3 controls PWM3/PWM4 pair
	1	PMVAL4 controls PWM3/PWM4 pair
IPOL3	0	PMVAL5 controls PWM5/PWM6 pair
	1	PMVAL6 controls PWM5/PWM6 pair

**NOTE:** The IPOLx bits are buffered so that only one PWM register is used per PWM cycle. If an IPOLx bit changes during a PWM period, the new value does not take effect until the next PWM period.

The IPOLx bits take effect at the end of each PWM cycle regardless of the state of the load okay bit, LDOK.

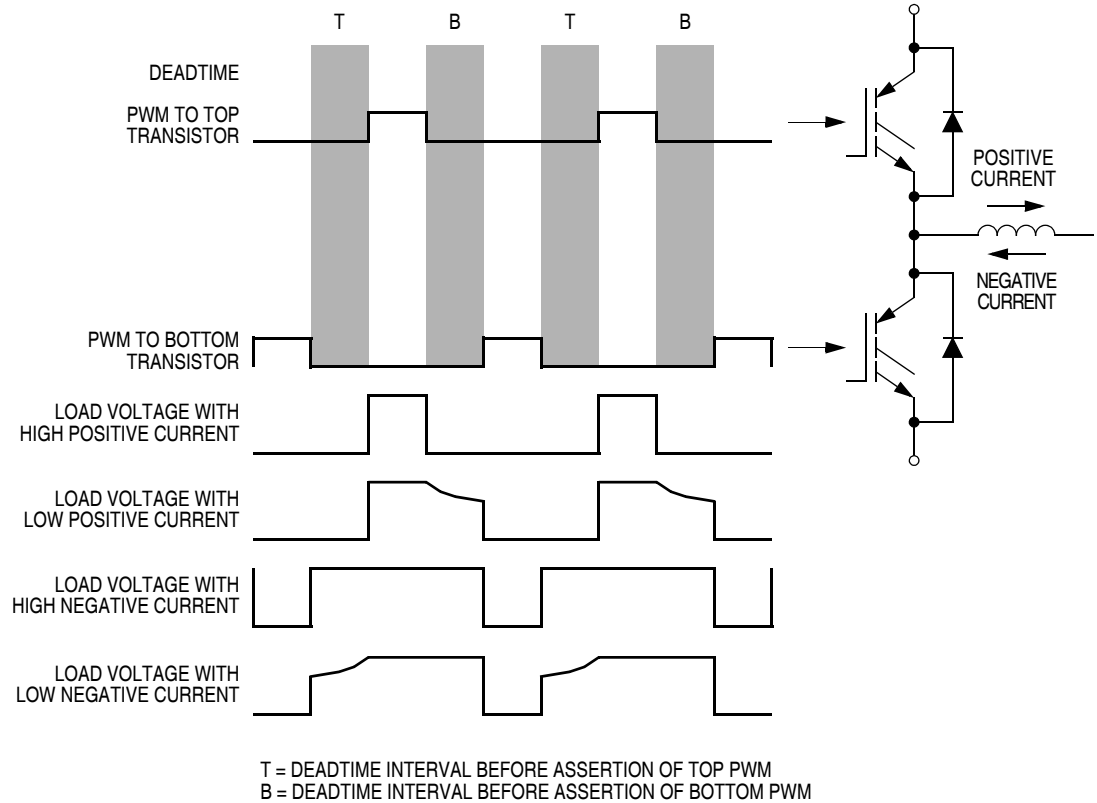


**Figure 9-20. Internal Correction Logic when ISENS[1:0] = 0X**

The best time to change from one PWMVAL register to another is just before the current zero crossing. [Figure 9-21](#) shows motor voltage waveforms under high current and low current conditions. During a



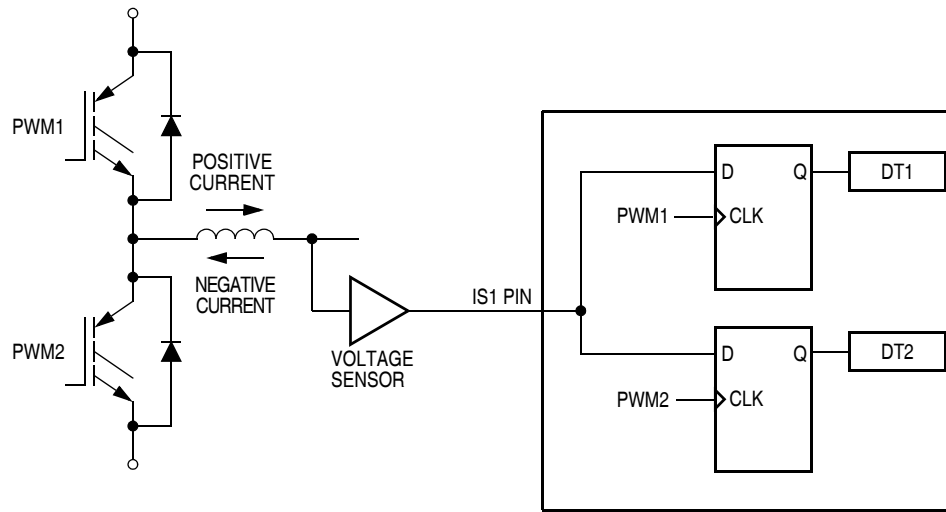
deadtime interval, the load voltage near a current zero crossing is somewhere between the high and low levels.



**Figure 9-21. Output Voltage Waveforms**

Each ISx pin is sampled twice in a PWM period. The values are stored in the DTx bits in the fault acknowledge register. The DTx bits are a timing marker to indicate when to toggle between PWMVAL register. In the low-current condition immediately before a current zero crossing, the two DTx bits in a pair have dissimilar values. Software can then set the IPOLx bit to toggle PWMVAL registers before the zero crossing occurs.

# Pulse Width Modulator for Motor Control (PWMMC)



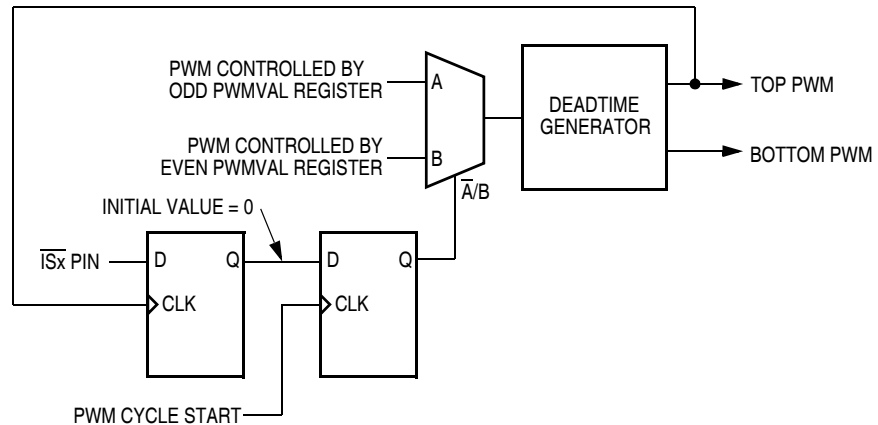
**Figure 9-22. DTx bits**

## 9.6.3.2 Automatic Correction

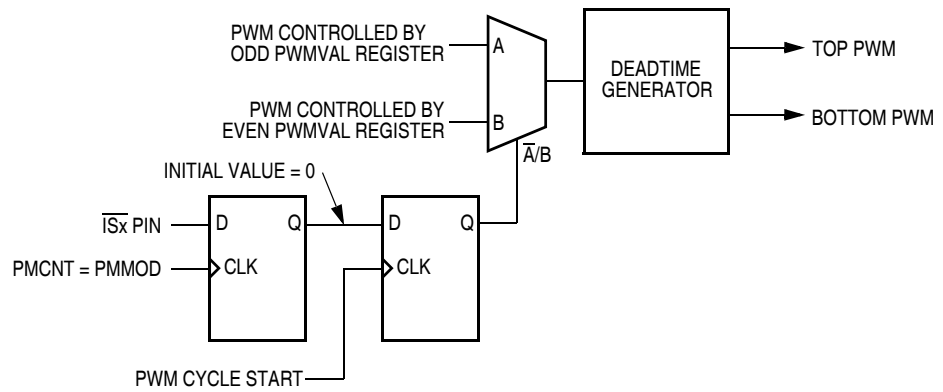
The current sense pin,  $\overline{ISx}$ , for a PWM pair selects either the odd or the even PWM value registers to use in the next PWM cycle. The selection is based on user-provided current sense circuitry driving the  $\overline{ISx}$  pin high for negative current and low for positive current.

**Table 9-6. Top/Bottom Current-Sense Correction**

Pin	Logic State	Output Control
$\overline{IS1}$	0	PMVAL1 controls PWM1/PWM2 pair
	1	PMVAL2 controls PWM1/PWM2 pair
$\overline{IS2}$	0	PMVAL3 controls PWM3/PWM4 pair
	1	PMVAL4 controls PWM3/PWM4 pair
$\overline{IS3}$	0	PMVAL5 controls PWM5/PWM6 pair
	1	PMVAL6 controls PWM5/PWM6 pair



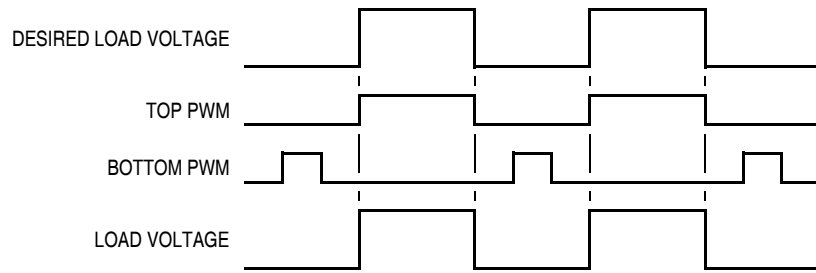
**Figure 9-23. Internal Correction Logic when ISENS[1:0] = 10**



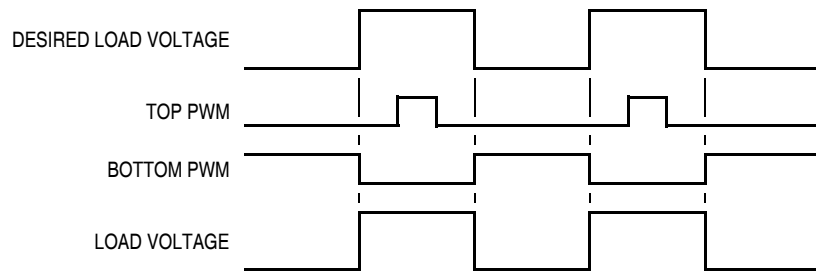
**Figure 9-24. Internal Correction Logic when ISENS[1:0] = 11**

**NOTE:** The values latched on the ISx pins are buffered so that only one PWM register is used per PWM cycle. If a current sense value changes during a PWM period, the new value does not take effect until the next PWM period.

When initially enabled by setting the PWMEN bit, no current has previously been sensed. PWM value registers 1, 3, and 5 initially control the three PWM pairs when configured for current sensing correction.



**Figure 9-25. Correction with Positive Current**



**Figure 9-26. Correction with Negative Current**

## 9.6.4 Output Polarity

The output polarity of the PWMs is determined by two options: TOPNEG and BOTNEG. The top polarity option, TOPNEG, controls the polarity of PWMs 1, 3, and 5. The bottom polarity option, BOTNEG, controls the polarity of PWMs 2, 4, and 6. Positive polarity means that when the PWM is active, the PWM output is high. Conversely, negative polarity means that when the PWM is active, PWM output is low. See [Figure 9-27](#) and [Section 5. Configuration Register \(CONFIG\)](#).

**NOTE:** *Both bits are found in the CONFIG register, which is a write-once register. This reduces the chances of the software inadvertently changing the polarity of the PWM signals and possibly damaging the motor drive hardware.*

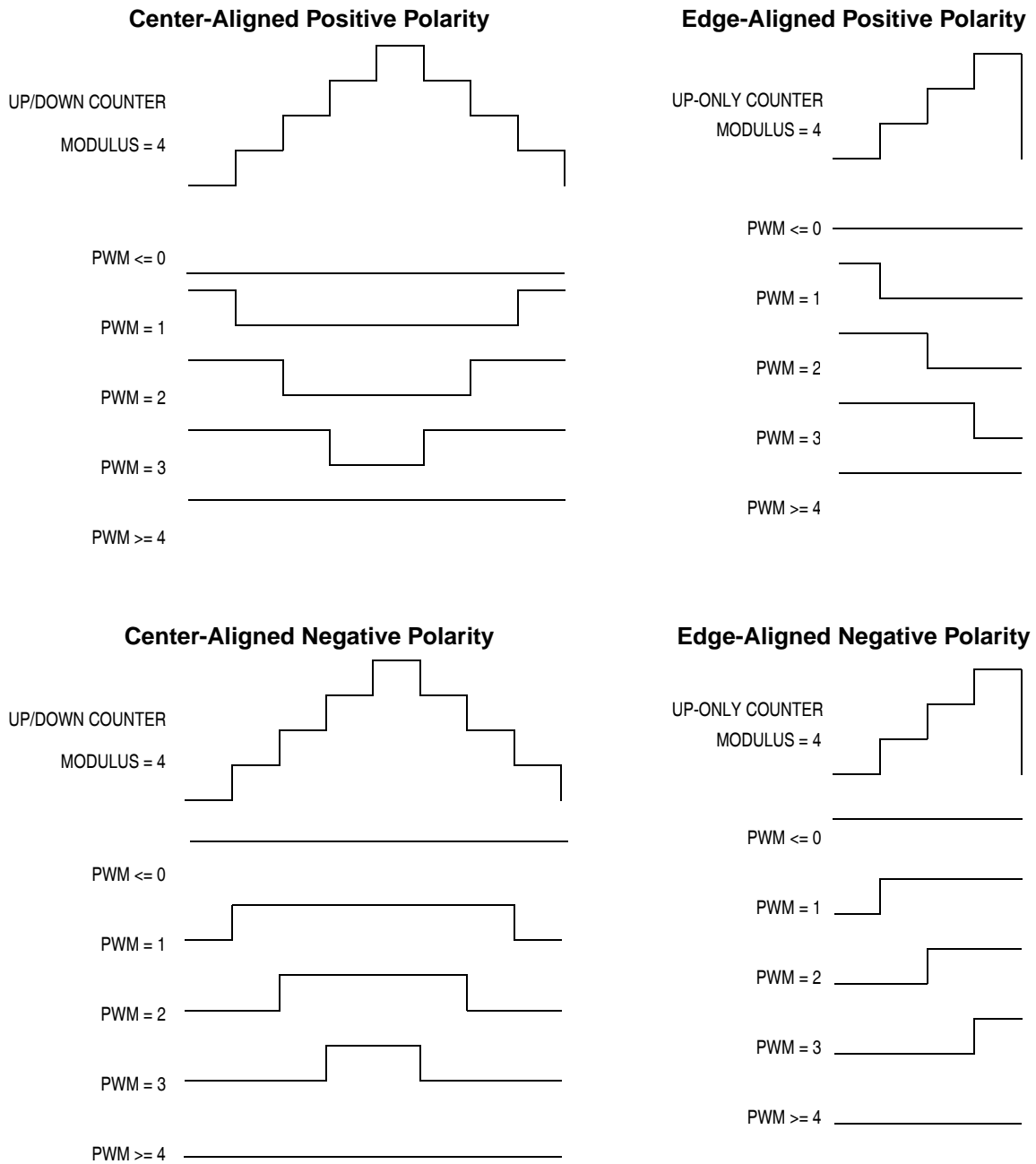
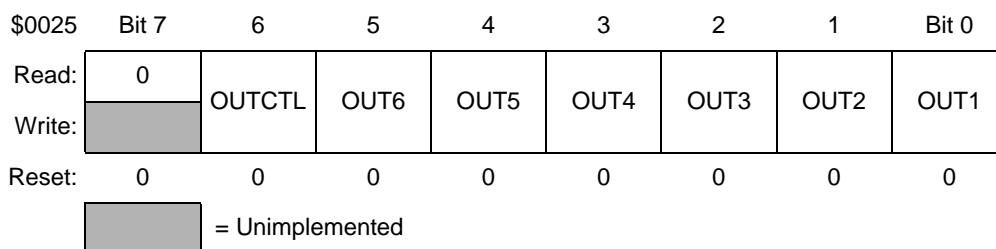


Figure 9-27. PWM Polarity

## 9.6.5 Output Port Control

Conditions may arise in which the PWM pins need to be individually controlled. This is made possible by the PWM output control register (PWMOOUT) shown in [Figure 9-28](#).



**Figure 9-28. PWM Output Control Register (PWMOOUT)**

If the OUTCTL bit is set, the PWM pins can be controlled by the OUTx bits. These bits behave according to [Table 9-7](#).

**Table 9-7. OUTx Bits**

OUTx Bit	Complementary Mode	Independent Mode
OUT1	1 — PWM1 is active 0 — PWM1 is inactive	1 — PWM1 is active 0 — PWM1 is inactive
OUT2	1 — PWM2 is complement of PWM 1 0 — PWM2 is inactive	1 — PWM2 is active 0 — PWM2 is inactive
OUT3	1 — PWM3 is active 0 — PWM3 is inactive	1 — PWM3 is active 0 — PWM3 is inactive
OUT4	1 — PWM4 is complement of PWM 3 0 — PWM4 is inactive	1 — PWM4 is active 0 — PWM4 is inactive
OUT5	1 — PWM5 is active 0 — PWM5 is inactive	1 — PWM5 is active 0 — PWM5 is inactive
OUT6	1 — PWM 6 is complement of PWM 5 0 — PWM6 is inactive	1 — PWM6 is active 0 — PWM6 is inactive

When OUTCTL is set, the polarity options TOPPOL and BOTPOL will still affect the outputs. In addition, if complementary operation is in use, the PWM pairs will not be allowed to be active simultaneously, and dead-time will still not be violated. When OUTCTL is set and complimentary operation is in use, the odd OUTx bits are inputs to the dead-time generators as shown in [Figure 9-13](#). Dead-time is inserted whenever

the odd OUTx bit toggles as shown in [Figure 9-29](#). Although dead-time is not inserted when the even OUTx bits change, there will be no dead-time violation as shown in [Figure 9-30](#).

Setting the OUTCTL bit does not disable the PWM generator and current sensing circuitry. They continue to run, but are no longer controlling the output pins. In addition, OUTCTL will control the PWM pins even when PWMEN = 0. When OUTCTL is cleared, the outputs of the PWM generator become the inputs to the dead-time and output circuitry at the beginning of the next PWM cycle.

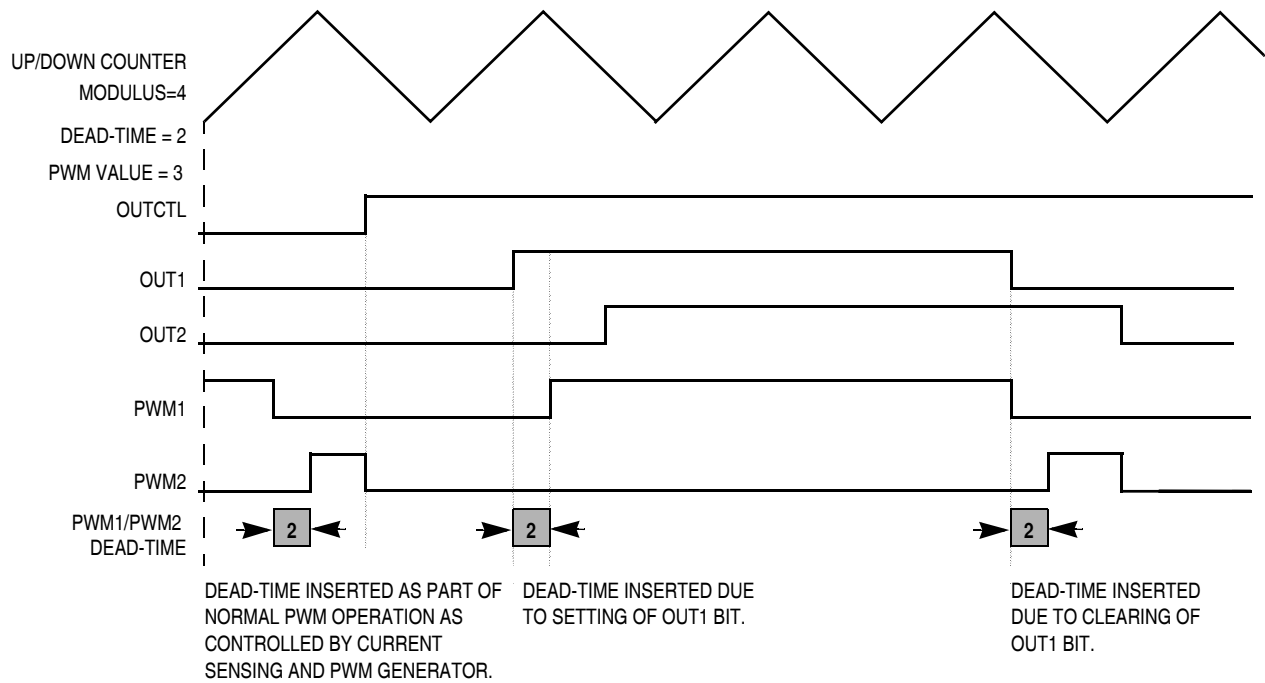
**NOTE:** *To avoid an unexpected dead-time occurrence, it is recommended that the OUTx bits be cleared prior to entering and prior to exiting individual PWM output control mode.*

## 9.7 Fault Protection

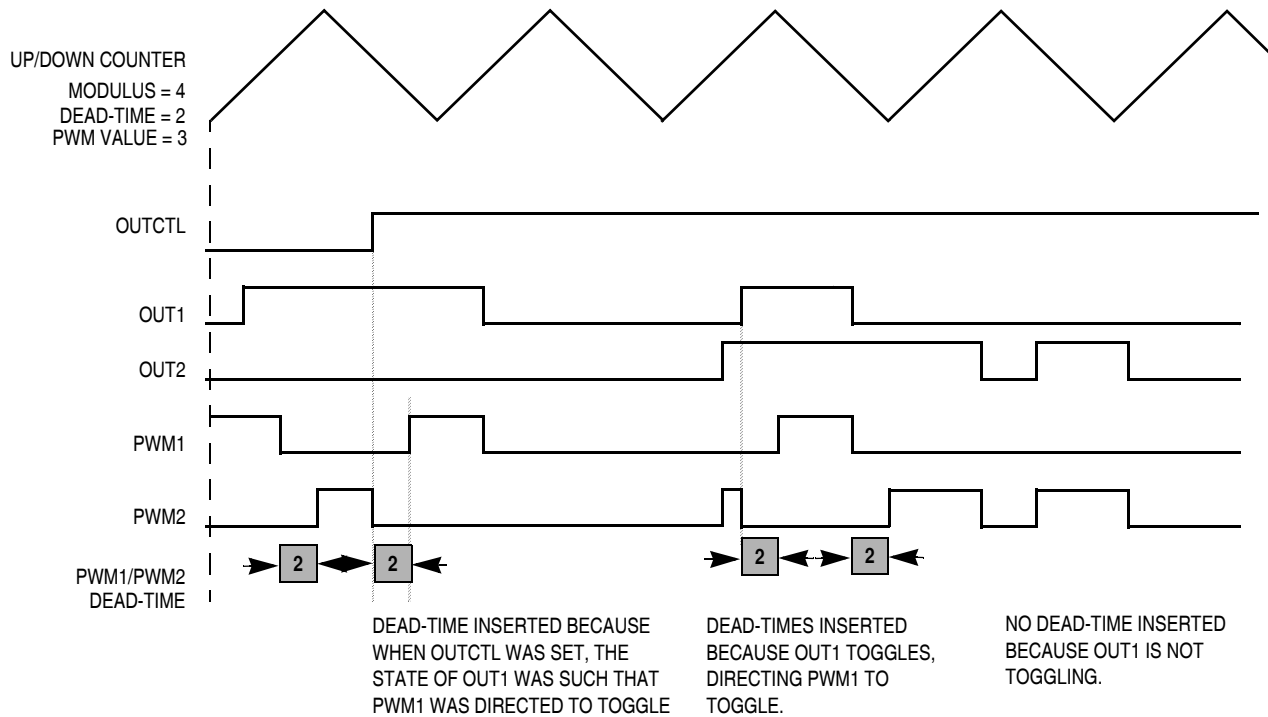
Conditions may arise in the external drive circuitry which require that the PWM signals become inactive immediately, such as an overcurrent fault condition. Furthermore, it may be desirable to selectively disable PWM(s) solely with software.

One or more PWM pins can be disabled (forced to their inactive state) by applying a logic high to any of the four external fault pins or by writing a logic high to either of the disable bits (DISX and DISY in PWM control register 1). [Figure 9-31](#) shows the structure of the PWM disabling scheme. While the PWM pins are disabled, they are forced to their inactive state. The PWM generator continues to run — only the output pins are disabled.

# Pulse Width Modulator for Motor Control (PWMMC)

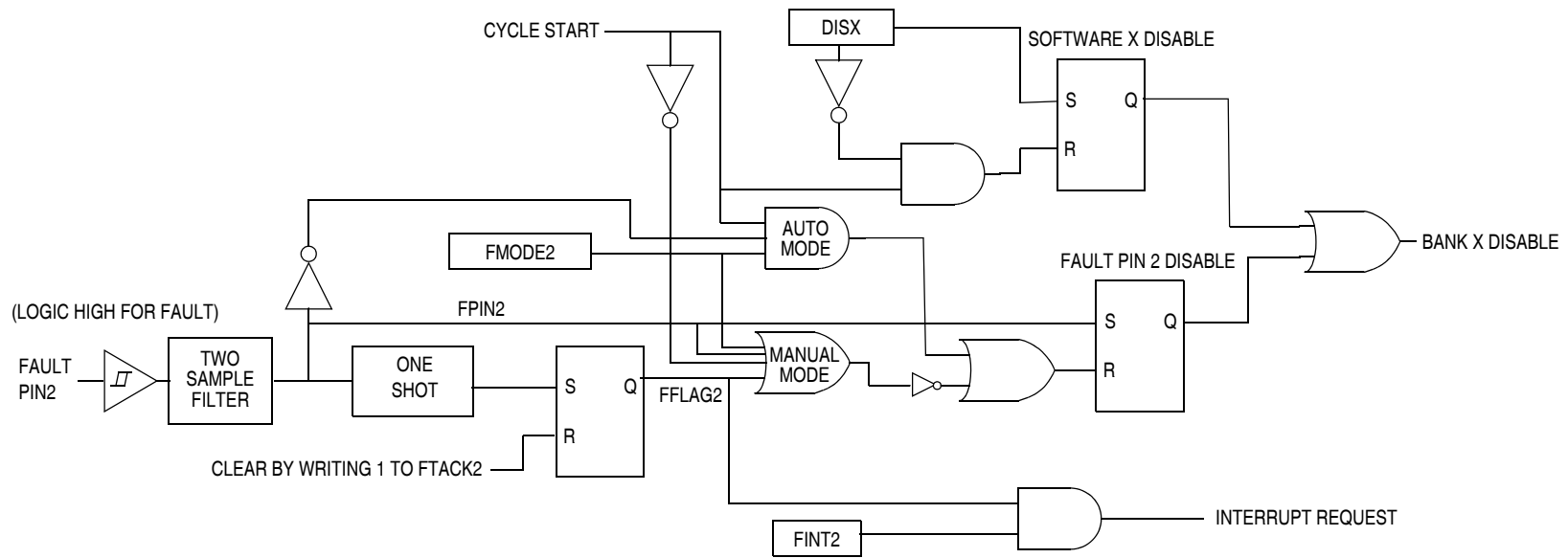


**Figure 9-29. Dead-Time Insertion During OUTCTL = 1**



**Figure 9-30. Dead-Time Insertion During OUTCTL = 1**

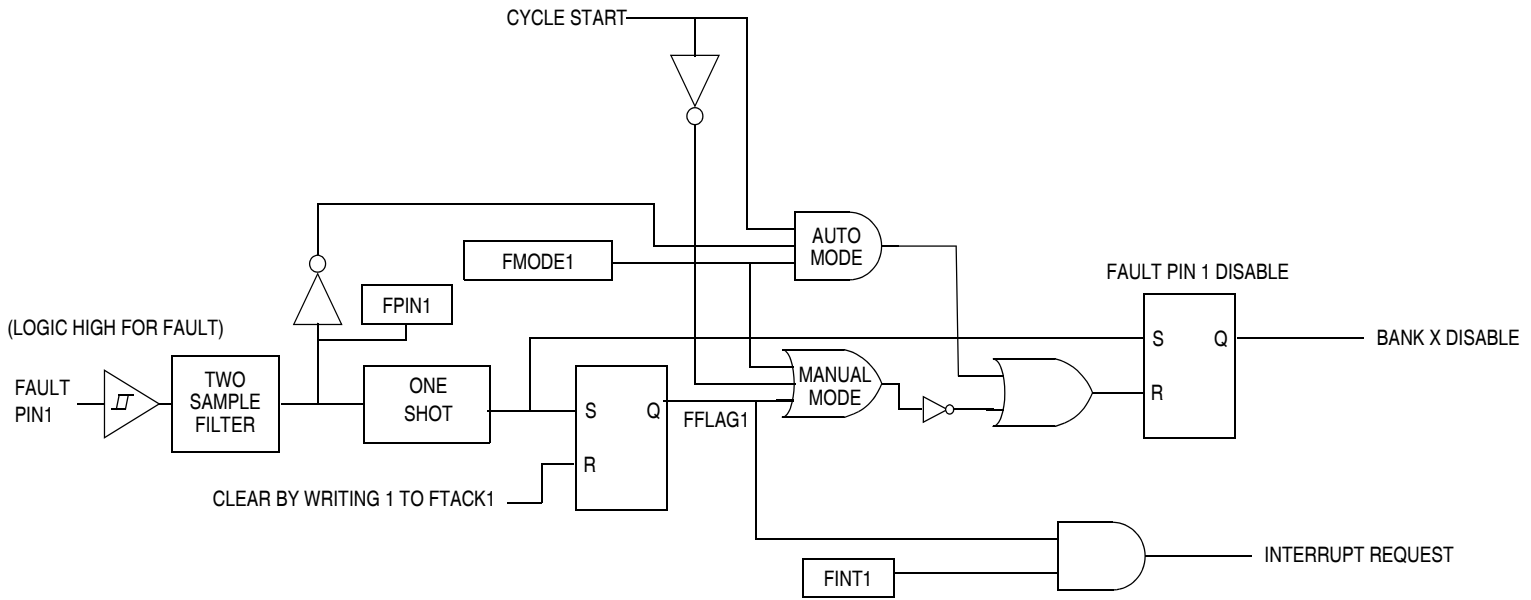




The example is of fault pin 2 with DISX. Fault pin 4 with DISY is logically similar and affects BANK Y disable.

NOTE: In manual mode (FMODE = 0) fault 2 and 4 may be cleared only if a logic level low at the input of the fault pin is present.

Figure 9-31. PWM Disabling Scheme (Sheet 1 of 2)



The example is of fault pin 1. Fault pin 3 is logically similar and effects BANK Y disable.

NOTE: In manual mode (FMODE = 0) fault 1 and 3 may be cleared regardless of the logic level at the input of the fault pin.

Figure 9-32. PWM Disabling Scheme (Sheet 2 of 2)

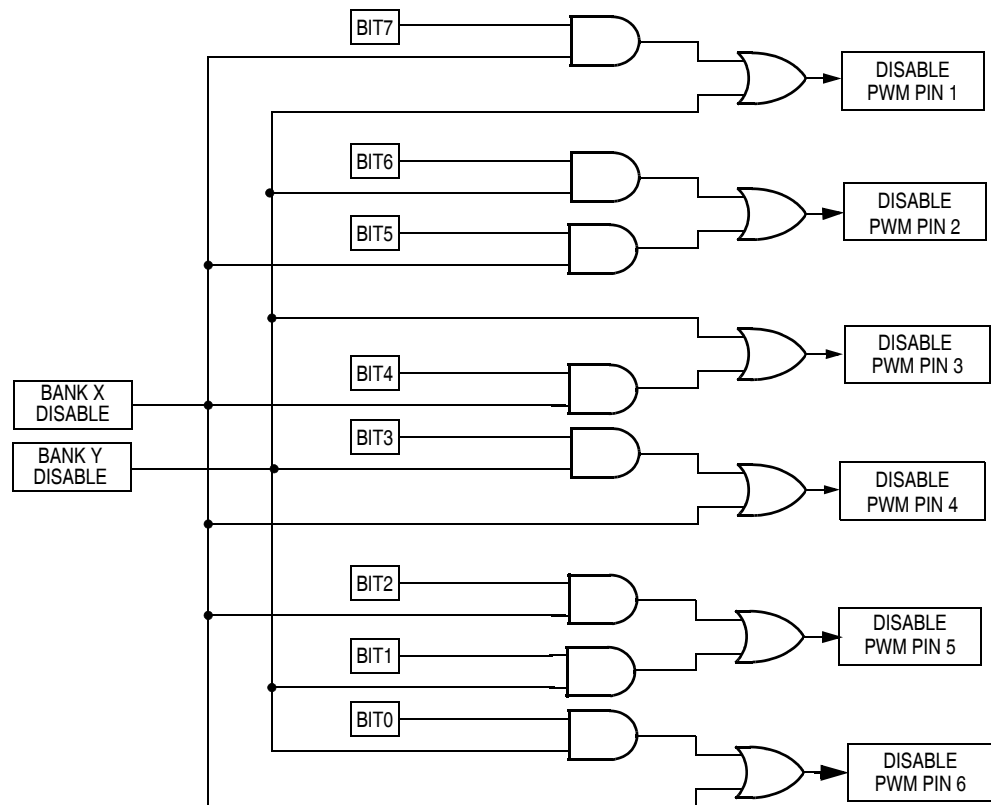
To allow for different motor configurations and the controlling of more than one motor, the PWM disabling function is organized as two banks, bank X and bank Y. Bank information combines with information from the disable mapping register to allow selective PWM disabling. Fault pin 1, fault pin 2, and PWM disable bit X constitute the disabling function of bank X. Fault pin 3, fault pin 4, and PWM disable bit Y constitute the disabling function of bank Y. [Figure 9-33](#) and [Figure 9-34](#) show the disable mapping write-once register and the decoding scheme of the bank which selectively disables PWM(s). When all bits of the disable mapping register are set, any disable condition will disable all PWMs.

A fault can also generate a CPU interrupt. Each fault pin has its own interrupt vector.

Address: \$0037

	Bit 7	6	5	4	3	2	1	Bit 0
Read:	BIT 7	BIT 6	BIT 5	BIT 4	BIT 3	BIT 2	BIT 1	BIT 0
Write:								
Reset:	1	1	1	1	1	1	1	1

**Figure 9-33. PWM Disable Mapping Write-Once Register (DISMAP)**



**Figure 9-34. PWM Disabling Decode Scheme**

## 9.7.1 Fault Condition Input Pins

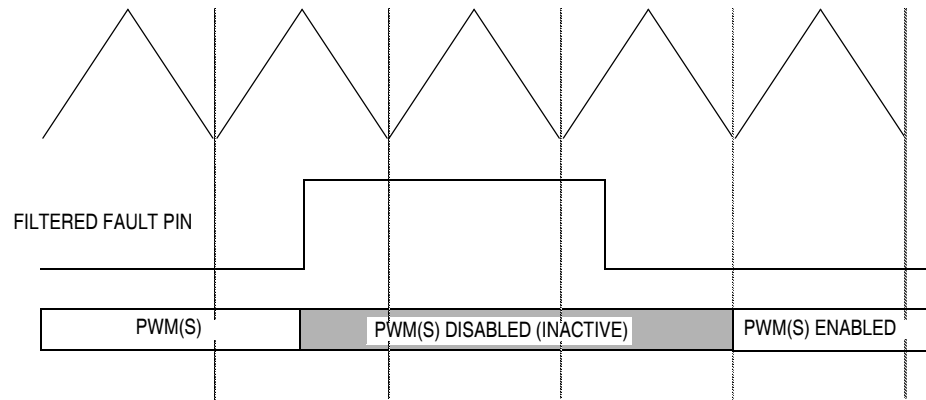
A logic high level on a fault pin disables the respective PWM(s) determined by the bank and the disable mapping register. Each fault pin incorporates a filter to assist in rejecting spurious faults. All of the external fault pins are software-configurable to re-enable the PWMs either with the fault pin (automatic mode) or with software (manual mode). Each fault pin has an associated FMODE bit to control the PWM re-enabling method. Automatic mode is selected by setting the FMODEx bit in the fault control register. Manual mode is selected when FMODEx is clear.

### 9.7.1.1 Fault Pin Filter

Each fault pin incorporates a filter to assist in determining a genuine fault condition. After a fault pin has been logic low for one CPU cycle, a rising edge (logic high) will be synchronously sampled once per CPU cycle for two cycles. If both samples are detected logic high, the corresponding FPIN bit and FFLAG bit will be set. The FPIN bit will remain set until the corresponding fault pin is logic low and synchronously sampled once in the following CPU cycle.

### 9.7.1.2 Automatic Mode

In automatic mode, the PWM(s) are disabled immediately once a filtered fault condition is detected (logic high). The PWM(s) remain disabled until the filtered fault condition is cleared (logic low) and a new PWM cycle begins as shown in [Figure 9-35](#). Clearing the corresponding FFLAGx event bit will not enable the PWMs in automatic mode.



**Figure 9-35. PWM Disabling in Automatic Mode**

The filtered fault pins' logic state is reflected in the respective FPINx bit. Any write to this bit is overwritten by the pin state. The FFLAGx event bit is set with each rising edge of the respective fault pin after filtering has been applied. To clear the FFLAGx bit, the user must write a 1 to the corresponding FTACKx bit.

If the FINTx bit is set, a fault condition resulting in setting the corresponding FFLAG bit will also latch a CPU interrupt request. The interrupt request latch is not cleared until one of the following actions occurs:

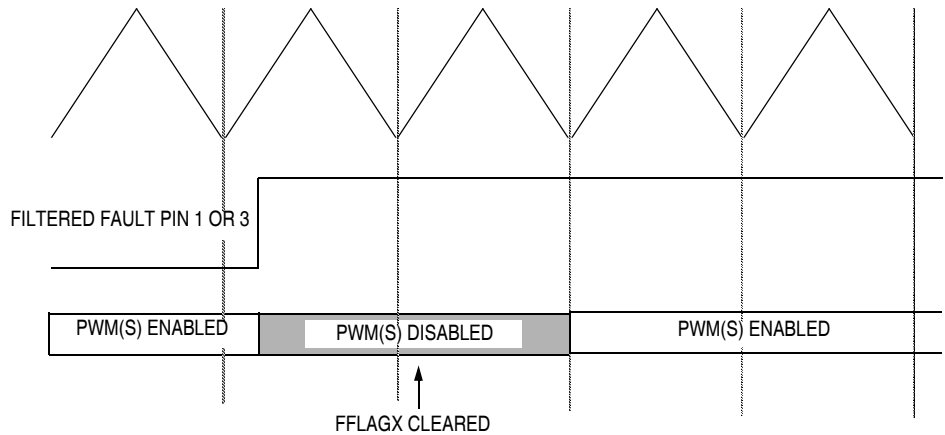
- The FFLAGx bit is cleared by writing a 1 to the corresponding FTACKx bit.
- Clearing the FINTx bit. (This will not clear the FFLAGx bit.)
- Reset — A reset automatically clears all four interrupt latches

If prior to a vector fetch, the interrupt request latch is cleared by one of the above actions, a CPU interrupt will no longer be requested. A vector fetch does not alter the state of the PWMs, the FFLAGx event flag or FINTx.

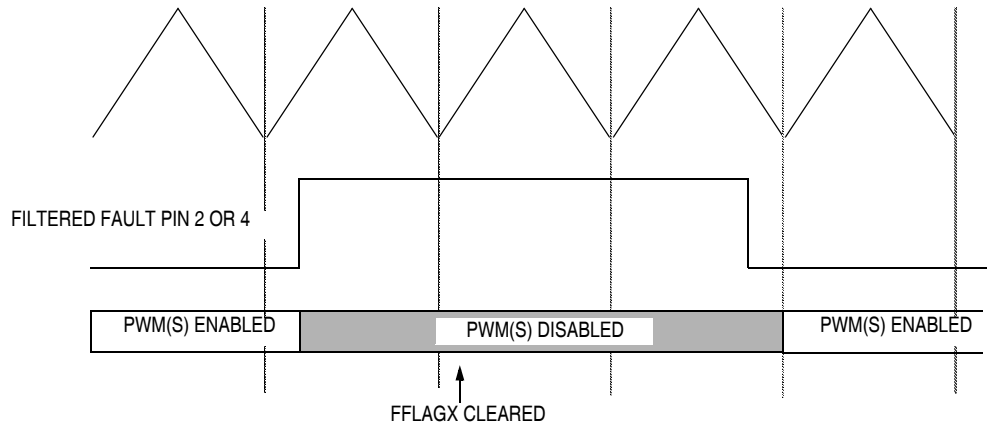
**NOTE:** *If the FFLAGx or FINTx bits are not cleared during the interrupt service routine, the interrupt request latch will not be cleared.*

### 9.7.1.3 Manual Mode

In manual mode, the PWM(s) are disabled immediately once a filtered fault condition is detected (logic high). The PWM(s) remain disabled until software clears the corresponding FFLAGx event bit and a new PWM cycle begins. In manual mode, the fault pins are grouped in pairs, each pair sharing common functionality. A fault condition on pins 1 and 3 may be cleared, allowing the PWM(s) to enable at the start of a PWM cycle regardless of the logic level at the fault pin. See [Figure 9-36](#). A fault condition on pins 2 and 4 can only be cleared, allowing the PWM(s) to enable, if a logic low level at the fault pin is present at the start of a PWM cycle. See [Figure 9-37](#).



**Figure 9-36. PWM Disabling in Manual Mode (Example 1)**



**Figure 9-37. PWM Disabling in Manual Mode (Example 2)**

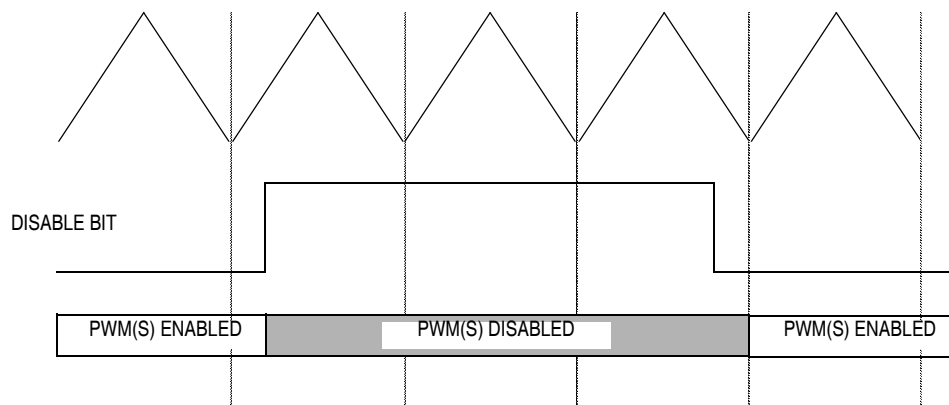
The function of the fault control and event bits is the same as in automatic mode except that the PWMs are not re-enabled until the FFLAGx event bit is cleared by writing to the FTACKx bit and the filtered fault condition is cleared (logic low).

## 9.7.2 Software Output Disable

Setting PWM disable bit DISX or DISY in PWM control register 1 immediately disables the corresponding PWM pins as determined by the bank and disable mapping register. The PWM pin(s) remain disabled until the PWM disable bit is cleared and a new PWM cycle begins as shown in [Figure 9-38](#). Setting a PWM disable bit does not latch a CPU interrupt request, and there are no event flags associated with the PWM disable bits.

## 9.7.3 Output Port Control

When operating the PWMs using the OUTx bits (OUTCTL = 1), fault protection applies as described in this section. Due to the absence of periodic PWM cycles, fault conditions are cleared upon each CPU cycle and the PWM outputs are re-enabled, provided all fault clearing conditions are satisfied.



**Figure 9-38. PWM Software Disable**



## 9.8 Initialization and the PWMEN Bit

For proper operation, all registers should be initialized and the LDOK bit should be set before enabling the PWM via the PWMEN bit. When the PWMEN bit is first set, a reload will occur immediately, setting the PWMF flag and generating an interrupt if PWMINT is set. In addition, in complementary mode, PWM value registers 1, 3, and 5 will be used for the first PWM cycle if current sensing is selected.

**NOTE:** *If the LDOK bit is not set when PWMEN is set after a  $\overline{RESET}$ , the prescaler and PWM values will be zero, but the modulus will be unknown. If the LDOK bit is not set after the PWMEN bit has been cleared then set (without a RESET), the modulus value that was last loaded will be used.*

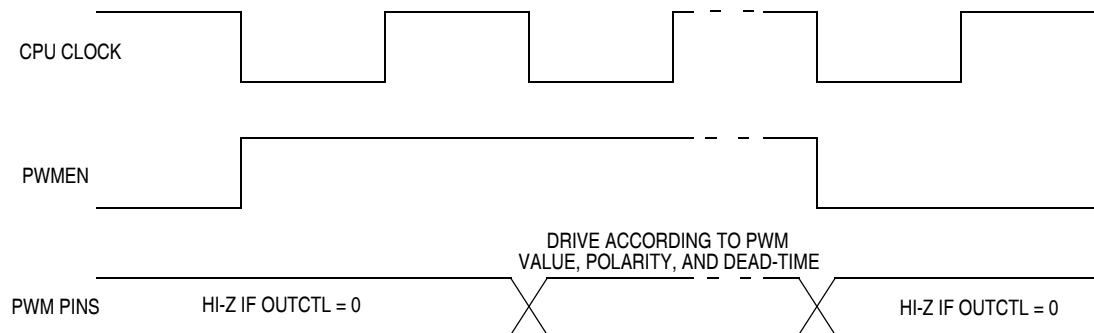
*If the dead-time register (DEADTM) is changed after PWMEN or OUTCTL is set, an improper dead-time insertion could occur. However, the dead time can never be shorter than the specified value.*

*Because of the equals-comparator architecture of this PWM, the modulus = 0 case is considered illegal. Therefore, the modulus register is not reset, and a modulus value of zero will result in waveforms inconsistent with the other modulus waveforms. See [9.11.2 PWM Counter Modulo Registers](#).*

When PWMEN is set, the PWM pins change from hi-Z to outputs. At this time, assuming no fault condition is present, the PWM pins will drive according to the PWM values, polarity, and dead-time. If the prescaler bits PRSC1:PRSC0 equal 00 (the default condition), the PWM pins will drive on the next CPU clock cycle, as shown by the timing diagram in [Figure 9-39](#).

**NOTE:** *The timing diagram in [Figure 9-39](#) is only applicable when PRSC1:PRSC0 = 00. If set to any other value, the PWM outputs will remain in the high-impedance condition for one complete PWM cycle before being driven.*

## Pulse Width Modulator for Motor Control (PWMMC)



**Figure 9-39. PWMEN and PWM Pins**

When the PWMEN bit is cleared, the following will occur:

- PWM pins will be tri-stated unless  $OUTCTL = 1$
- PWM counter is cleared and will not be clocked
- Internally, the PWM generator will force its outputs to zero (to avoid glitches when the PWMEN is set again)

When PWMEN is cleared, the following features remain active:

- All fault circuitry
- Manual PWM pin control via the PWMOUT register
- Dead-time insertion when PWM pins change via the PWMOUT register

**NOTE:** *The PWMF flag and pending CPU interrupts are NOT cleared when  $PWMEN = 0$ .*

## 9.9 PWM Operation in Wait Mode

When the microcontroller is put in low-power wait mode via the WAIT instruction, all clocks to the PWM module will continue to run. If an interrupt is issued from the PWM module (via a reload or a fault), the microcontroller will exit wait mode.

Clearing the PWMEN bit before entering wait mode will reduce power consumption in wait mode because the counter, prescaler divider, and LDFQ divider will no longer be clocked. In addition, power will be reduced because the PWMs will no longer toggle.

## 9.10 PWM Operation in Break Mode

If the microcontroller goes into break mode (or background mode), the clocks to the PWM generator and output control blocks will freeze. This allows the user to set a breakpoint on a development system and examine the register contents and PWM outputs at that point. It also allows the user to single-step through the code.

The clocks to the fault block will continue to run. Therefore, if a fault occurs while the microcontroller is in break mode, the PWM outputs will immediately be driven to their inactive state(s).

During break mode, the system integration module (SIM) controls whether status bits in other modules can be cleared during the break state. The BCFE bit in the SIM break flag control register (SBFCR) enables software to clear status bits during the break state. (See [7.7.4 SIM Break Flag Control Register](#).)

To allow software to clear status bits during a break interrupt, write a logic 1 to the BCFE bit. If a status bit is cleared during the break state, it remains cleared when the MCU exits the break state.

To protect the PWMF and FFLAGx bits during the break state, make sure BCFE is a logic 0. With BCFE at logic 0 (its default state), software can read and write the status and control registers during the break state without affecting the PWMF and FFLAGx bits.

## 9.11 Control Logic Block

The following subsections provide a description of the control logic block.

### 9.11.1 PWM Counter Registers

This PWM counter register displays the 12-bit up/down or up-only counter. When the high byte of the counter is read, the lower byte is latched. PCNTL will hold this latched value until it is read.

PCNTH		Bit 7	6	5	4	3	2	1	Bit 0
Address:	\$0026								
Read:		0	0	0	0	11	10	9	BIT 8
Write:									
Reset:		0	0	0	0	0	0	0	0

PCNTL		Bit 7	6	5	4	3	2	1	Bit 0
Address:	\$0027								
Read:		BIT 7	BIT 6	BIT 5	BIT 4	BIT 3	BIT 2	BIT 1	BIT 0
Write:									
Reset:		0	0	0	0	0	0	0	0

= Unimplemented

**Figure 9-40. PWM Counter Registers (PCNTH:PCNTL)**


### 9.11.2 PWM Counter Modulo Registers

This PWM counter modulus register holds a 12-bit unsigned number that determines the maximum count for the up/down or up-only counter. In center-aligned mode, the PWM period will be twice the modulus (assuming no prescaler). In edge-aligned mode, the PWM period will equal the modulus.

PMDH \$0028		Bit 7	6	5	4	3	2	1	Bit 0
Read:		0	0	0	0	11	10	9	BIT 8
Write:									
Reset:		0	0	0	0	X	X	X	X

PMDL \$0029		Bit 7	6	5	4	3	2	1	Bit 0
Read:		BIT 7	BIT 6	BIT 5	BIT 4	BIT 3	BIT 2	BIT 1	BIT 0
Write:									
Reset:		X	X	X	X	X	X	X	X

 = Unimplemented

**Figure 9-41. PWM Counter Modulo Registers (PDMODH:PMDL)**

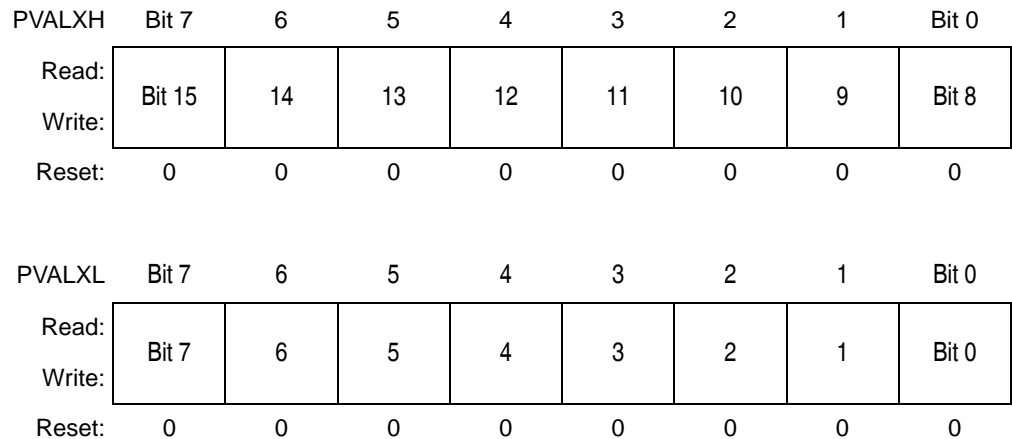
To avoid erroneous PWM periods, this value is buffered and will not be used by the PWM generator until the LDOK bit has been set and the next PWM load cycle begins.

**NOTE:** *When reading this register, the value read is the buffer (not necessarily the value the PWM generator is currently using).*

**CAUTION:** *The user is responsible for initializing the PWM counter modulo registers before enabling the PWM module. Since these registers are undefined at reset, they could contain a combined value of \$0000, which would result in erroneous pulse widths. However, the dead-time constraints will still be guaranteed, and the fault detection circuitry will still function properly.*

## 9.11.3 PWM X Value Registers

Each of the six PWMs has a 16-bit PWM value register.



**Figure 9-42. PWM X Value Registers (PVALXH:PVALXL)**

The 16-bit signed value stored in this register determines the duty cycle of the PWM. The duty cycle is defined as:  $(\text{PWM value}/\text{modulus}) \times 100$ .

Writing a number less than or equal to zero causes the PWM to be off for the entire PWM period. Writing a number greater than or equal to the 12-bit modulus causes the PWM to be on for the entire PWM period.

If the complementary mode is selected, the PWM pairs share PWM value registers.

To avoid erroneous PWM pulses, this value is buffered and will not be used by the PWM generator until the LDOK bit has been set and the next PWM load cycle begins.

**NOTE:** *When reading these registers, the value read is the buffer (not necessarily the value the PWM generator is currently using).*

### 9.11.4 PWM Control Register 1

PWM control register 1 controls PWM enabling/disabling, the loading of new modulus, prescaler, and PWM values, and the PWM correction method. In addition, this register contains the software disable bits to force the PWM outputs to their inactive states (according to the disable mapping register).

Address: \$0020

	Bit 7	6	5	4	3	2	1	Bit 0
Read:	DISX	DISY	PWMINT	PWMF	ISENS1	ISENS0	0	PWMEN
Write:							LDOK	
Reset:	0	0	0	0	0	0	0	0

**Figure 9-43. PWM Control Register 1 (PCTL1)**

#### PWMEN — PWM Module Enable

This read/write bit enables and disables the PWM generator and the PWM pins. When PWMEN is clear, the PWM generator is disabled and the PWM pins are in the high-impedance state (unless OUTCTL = 1).

When the PWMEN bit is set, the PWM generator and PWM pins are activated.

For more information, see [9.8 Initialization and the PWMEN Bit](#).

- 1 = PWM generator and PWM pins enabled
- 0 = PWM generator and PWM pins disabled

#### LDOK— Load OK

This write-only bit allows the counter modulus, counter prescaler, and PWM values in the buffered registers to be used by the PWM generator. These values will not be used until the LDOK bit is set and a new PWM load cycle begins. Internally this bit is automatically cleared after the new values are loaded (however, this bit always reads zero).

- 1 = Okay to load new modulus, prescaler, and PWM values at beginning of next PWM load cycle
- 0 = Not okay to load new modulus, prescaler, and PWM values

**NOTE:** The user should initialize the PWM registers and set the LDOK bit before enabling the PWM.

A PWM CPU interrupt request can still be generated when LDOK is zero.

## ISENS1:ISENS0 — Current Sense Correction Bits

These read/write bits select the top/bottom correction scheme as shown in [Table 9-8](#).

**Table 9-8. Correction Methods**

Current Correction Bits ISENS1:ISENS0	Correction Method
00 01	Bits IPOL1, IPOL2, and IPOL3 used for correction
10	Current sensing on pins IS1, IS2, and IS3 occurs during the dead-time.
11	Current sensing on pins IS1, IS2, and IS3 occurs at the half cycle in center-aligned mode and at the end of the cycle in edge-aligned mode.

## PWMF— PWM Reload Flag

This read/write bit is set at the beginning of every reload cycle regardless of the state of the LDOK bit. This bit is cleared by reading PWM control register 1 with the PWMF flag set, then writing a logic 0 to PWMF. If another reload occurs before the clearing sequence is complete, then writing logic 0 to PWMF has no effect.

1 = New reload cycle began

0 = New reload cycle has not begun

**NOTE:** When PWMF is cleared, pending PWM CPU interrupts are cleared (not including fault interrupts).

## PWMINT — PWM Interrupt Enable

This read/write bit allows the user to enable and disable PWM CPU interrupts. If set, a CPU interrupt will be pending when the PWMF flag is set.

1 = Enable PWM CPU interrupts

0 = Disable PWM CPU interrupts



**NOTE:** When PWMINT is cleared, pending CPU interrupts are inhibited.

#### DISX — Software Disable for Bank X

This read/write bit allows the user to disable one or more PWM pins in bank X. The pins that are disabled are determined by the disable mapping write-once register.

1 = Disable PWM pins in bank X

0 = Re-enable PWM pins at beginning of next PWM cycle

#### DISY — Software Disable for Bank Y

This read/write bit allows the user to disable one or more PWM pins in bank Y. The pins that are disabled are determined by the disable mapping write-once register.

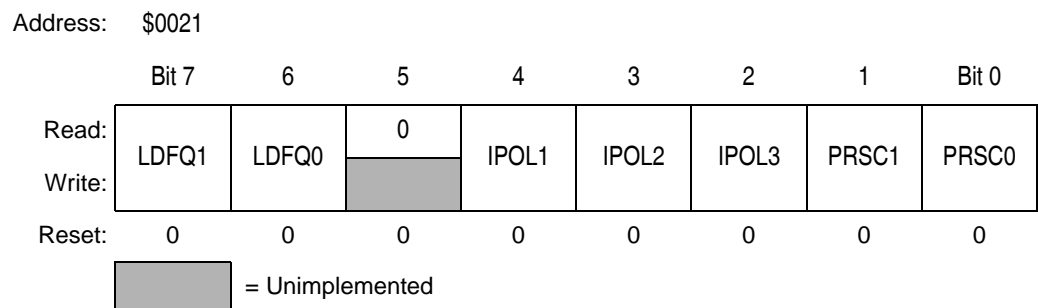
1 = Disable PWM pins in bank Y

0 = Re-enable PWM pins at beginning of next PWM cycle

### 9.11.5 PWM Control Register 2

PWM control register 2 controls the PWM load frequency, the PWM correction method, and the PWM counter prescaler. For ease of software and to avoid erroneous PWM periods, some of these register bits are buffered. The PWM generator will not use the prescaler value until the LDOK bit has been set, and a new PWM cycle is starting. The correction bits are used at the beginning of each PWM cycle (if the ISENSx bits are configured for software correction). The load frequency bits are not used until the current load cycle is complete.

**NOTE:** The user should initialize this register before enabling the PWM.



**Figure 9-44. PWM Control Register 2 (PCTL2)**

LDFQ1:LDFQ0 — PWM Load Frequency Bits

These buffered read/write bits select the PWM CPU load frequency according to [Table 9-9](#).

**NOTE:** *When reading these bits, the value read is the buffer value (not necessarily the value the PWM generator is currently using).*

**Table 9-9. PWM Reload Frequency**

Reload Frequency Bits LDFQ1:LDFQ0	PWM Reload Frequency
00	Every PWM cycle
01	Every 2 PWM cycles
10	Every 4 PWM cycles
11	Every 8 PWM cycles

IPOL1 — Top/Bottom Correction Bit for PWM Pair 1 (PWMs 1 and 2)

This buffered read/write bit selects which PWM value register is used if top/bottom correction is to be achieved without current sensing.

1 = Use PWM value register 2

0 = Use PWM value register 1

**NOTE:** *When reading this bit, the value read is the buffer value (not necessarily the value the output control block is currently using).*

IPOL2 — Top/Bottom Correction Bit for PWM Pair 2 (PWMs 3 and 4)

This buffered read/write bit selects which PWM value register is used if top/bottom correction is to be achieved without current sensing.

1 = Use PWM value register 4

0 = Use PWM value register 3

**NOTE:** *When reading this bit, the value read is the buffer value (not necessarily the value the output control block is currently using).*

IPOL3 — Top/Bottom Correction Bit for PWM Pair 3 (PWMs 5 and 6)

This buffered read/write bit selects which PWM value register is used if top/bottom correction is to be achieved without current sensing.

1 = Use PWM value register 6

0 = Use PWM value register 5

**NOTE:** When reading this bit, the value read is the buffer value (not necessarily the value the output control block is currently using).

#### PRSC1:PRSC0 — PWM Prescaler Bits

These buffered read/write bits allow the PWM clock frequency to be modified as shown in [Table 9-10](#).

**NOTE:** When reading these bits, the value read is the buffer value (not necessarily the value the PWM generator is currently using).

**Table 9-10. PWM Prescaler**

Prescaler Bits PRSC1:PRSC0	PWM Clock Frequency
00	$f_{op}$
01	$f_{op}/2$
10	$f_{op}/4$
11	$f_{op}/8$

### 9.11.6 Dead-Time Write-Once Register

This write-once register holds an 8-bit value which specifies the number of CPU clock cycles to use for the dead-time when complementary PWM mode is selected. After this register is written for the first time, it cannot be rewritten unless a RESET occurs. The dead-time is not affected by changes to the prescaler value.

Address: \$0036

	Bit 7	6	5	4	3	2	1	Bit 0
Read:	BIT 7	BIT 6	BIT 5	BIT 4	BIT 3	BIT 2	BIT 1	BIT 0
Write:								
Reset:	1	1	1	1	1	1	1	1

**Figure 9-45. Dead-Time Write-Once Register (DEADTM)**

## 9.11.7 PWM Disable Mapping Write-Once Register

This write-once register holds an 8-bit value which determines which PWM pins will be disabled if an external fault or software disable occur. For a further description of the disable mapping, see [9.7 Fault Protection](#). After this register is written for the first time, it cannot be rewritten unless a RESET occurs.

Address: \$0037

	Bit 7	6	5	4	3	2	1	Bit 0
Read:	BIT 7	BIT 6	BIT 5	BIT 4	BIT 3	BIT 2	BIT 1	BIT 0
Write:								
Reset:	1	1	1	1	1	1	1	1

**Figure 9-46. PWM Disable Mapping Write-Once Register (DISMAP)**

## 9.11.8 Fault Control Register

This register controls the fault protection circuitry.

Address: #0022

	Bit 7	6	5	4	3	2	1	Bit 0
Read:	FINT4	FMODE4	FINT3	FMODE3	FINT2	FMODE2	FINT1	FMODE1
Write:								
Reset:	0	0	0	0	0	0	0	0

**Figure 9-47. Fault Control Register (FCR)**

FMODE1 — Fault Mode Selection for Fault Pin 1 (Automatic versus Manual Mode)

This read/write bit allows the user to select between automatic and manual mode faults. For further description of each mode, see [9.7 Fault Protection](#).

- 1 = Automatic mode
- 0 = Manual mode

**FINT1 — Fault 1 Interrupt Enable**

This read/write bit allows the CPU interrupt caused by faults on fault pin 1 to be enabled. The fault protection circuitry is independent of this bit and will always be active. If a fault is detected, the PWM pins will still be disabled according to the disable mapping register.

1 = Fault pin 1 will cause CPU interrupts

0 = Fault pin 1 will not cause CPU interrupts

**FMODE2 — Fault Mode Selection for Fault Pin 2 (Automatic versus Manual Mode)**

This read/write bit allows the user to select between automatic and manual mode faults. For further description of each mode, see [9.7 Fault Protection](#).

1 = Automatic mode

0 = Manual mode

**FINT2 — Fault 2 Interrupt Enable**

This read/write bit allows the CPU interrupt caused by faults on fault pin 2 to be enabled. The fault protection circuitry is independent of this bit and will always be active. If a fault is detected, the PWM pins will still be disabled according to the disable mapping register.

1 = Fault pin 2 will cause CPU interrupts

0 = Fault pin 2 will not cause CPU interrupts

**FMODE3 — Fault Mode Selection for Fault Pin 3 (Automatic versus Manual Mode)**

This read/write bit allows the user to select between automatic and manual mode faults. For further description of each mode, see [9.7 Fault Protection](#).

1 = Automatic mode

0 = Manual mode

### FINT3 — Fault 3 Interrupt Enable

This read/write bit allows the CPU interrupt caused by faults on fault pin 3 to be enabled. The fault protection circuitry is independent of this bit and will always be active. If a fault is detected, the PWM pins will still be disabled according to the disable mapping register.

1 = Fault pin 3 will cause CPU interrupts

0 = Fault pin 3 will not cause CPU interrupts

### FMODE4 — Fault Mode Selection for Fault Pin 4 (Automatic versus Manual Mode)

This read/write bit allows the user to select between automatic and manual mode faults. For further description of each mode, see [9.7 Fault Protection](#).

1 = Automatic mode

0 = Manual mode

### FINT4 — Fault 4 Interrupt Enable

This read/write bit allows the CPU interrupt caused by faults on fault pin 4 to be enabled. The fault protection circuitry is independent of this bit and will always be active. If a fault is detected, the PWM pins will still be disabled according to the disable mapping register.

1 = Fault pin 4 will cause CPU interrupts

0 = Fault pin 4 will not cause CPU interrupts

### 9.11.9 Fault Status Register

This read-only register indicates the current fault status.

Address: \$0023

	Bit 7	6	5	4	3	2	1	Bit 0
Read:	FPIN4	FFLAG4	FPIN3	FFLAG3	FPIN2	FFLAG2	FPIN1	FFLAG1
Write:								
Reset:	U	0	U	0	U	0	U	0

= Unimplemented      U = Unaffected

**Figure 9-48. Fault Status Register (FSR)**

#### FFLAG1 — Fault Event Flag 1

The FFLAG1 event bit is set within two CPU cycles after a rising edge on fault pin 1. To clear the FFLAG1 bit, the user must write a 1 to the FTACK1 bit in the fault acknowledge register.

- 1 = A fault has occurred on fault pin 1
- 0 = No new fault on fault pin 1

#### FPIN1 — State of Fault Pin 1

This read-only bit allows the user to read the current state of fault pin 1.

- 1 = Fault pin 1 is at logic 1
- 0 = Fault pin 1 is at logic 0

#### FFLAG2 — Fault Event Flag 2

The FFLAG2 event bit is set within two CPU cycles after a rising edge on fault pin 2. To clear the FFLAG2 bit, the user must write a 1 to the FTACK2 bit in the fault acknowledge register.

- 1 = A fault has occurred on fault pin 2
- 0 = No new fault on fault pin 2

#### FPIN2 — State of Fault Pin 2

This read-only bit allows the user to read the current state of fault pin 2.

- 1 = Fault pin 2 is at logic 1
- 0 = Fault pin 2 is at logic 0

### FFLAG3 — Fault Event Flag 3

The FFLAG3 event bit is set within two CPU cycles after a rising edge on fault pin 3. To clear the FFLAG3 bit, the user must write a 1 to the FTACK3 bit in the fault acknowledge register.

1 = A fault has occurred on fault pin 3

0 = No new fault on fault pin 3

### FPIN3 — State of Fault Pin 3

This read-only bit allows the user to read the current state of fault pin 3.

1 = Fault pin 3 is at logic 1

0 = Fault pin 3 is at logic 0

### FFLAG4 — Fault Event Flag 4

The FFLAG4 event bit is set within two CPU cycles after a rising edge on fault pin 4. To clear the FFLAG4 bit, the user must write a 1 to the FTACK4 bit in the fault acknowledge register.

1 = A fault has occurred on fault pin 4

0 = No new fault on fault pin 4

### FPIN4 — State of Fault Pin 4

This read-only bit allows the user to read the current state of fault pin 4.

1 = Fault pin 4 is at logic 1

0 = Fault pin 4 is at logic 0




### 9.11.10 Fault Acknowledge Register

This register is used to acknowledge and clear the FFLAGS. In addition, it is used to monitor the current sensing bits to test proper operation.

Address: \$0024

	Bit 7	6	5	4	3	2	1	Bit 0
Read:	0	0	DT6	DT5	DT4	DT3	DT2	DT1
Write:		FTACK4		FTACK3		FTACK2		FTACK1
Reset:	0	0	0	0	0	0	0	0

 = Unimplemented

**Figure 9-49. Fault Acknowledge Register (FTACK)**

#### FTACK1 — Fault Acknowledge 1

The FTACK1 bit is used to acknowledge and clear FFLAG1. This bit will always read 0. Writing a 1 to this bit will clear FFLAG1. Writing a 0 will have no effect.

#### FTACK2 — Fault Acknowledge 2

The FTACK2 bit is used to acknowledge and clear FFLAG2. This bit will always read 0. Writing a 1 to this bit will clear FFLAG2. Writing a 0 will have no effect.

#### FTACK3 — Fault Acknowledge 3

The FTACK3 bit is used to acknowledge and clear FFLAG3. This bit will always read 0. Writing a 1 to this bit will clear FFLAG3. Writing a 0 will have no effect.

#### FTACK4 — Fault Acknowledge 4

The FTACK4 bit is used to acknowledge and clear FFLAG4. This bit will always read 0. Writing a 1 to this bit will clear FFLAG4. Writing a 0 will have no effect.

#### DT1 — Dead Time 1

Current sensing pin IS1 is monitored immediately before dead time ends due to the assertion of PWM1.

## DT1 — Dead Time 2

Current sensing pin IS1 is monitored immediately before dead time ends due to the assertion of PWM2.

## DT1 — Dead Time 3

Current sensing pin IS2 is monitored immediately before dead time ends due to the assertion of PWM3.

## DT1 — Dead Time 4

Current sensing pin IS2 is monitored immediately before dead time ends due to the assertion of PWM4.

## DT1 — Dead Time 5

Current sensing pin IS3 is monitored immediately before dead time ends due to the assertion of PWM5.


## DT1 — Dead Time 6

Current sensing pin IS3 is monitored immediately before dead time ends due to the assertion of PWM6.

### 9.11.11 PWM Output Control Register

This register is used to manually control the PWM pins.

\$0025	Bit 7	6	5	4	3	2	1	Bit 0
Read:	0	OUTCTL	OUT6	OUT5	OUT4	OUT3	OUT2	OUT1
Write:								
Reset:	0	0	0	0	0	0	0	0

 = Unimplemented

**Figure 9-50. PWM Output Control Register (PWMOUT)**

#### OUTCTL— Output Control Enable

This read/write bit allows the user to manually control the PWM pins. When set, the PWM generator is no longer the input to the dead-time and output circuitry. The OUTx bits determine the state of the PWM pins. Setting the OUTCTL bit does not disable the PWM generator.

The generator continues to run, but is no longer the input to the PWM dead-time and output circuitry. When OUTCTL is cleared, the outputs of the PWM generator immediately become the inputs to the dead-time and output circuitry.

1 = PWM outputs controlled manually

0 = PWM outputs determined by PWM generator

#### OUT6:OUT1— PWM Pin Output Control Bits

These read/write bits control the PWM pins according to [Table 9-11](#).

**Table 9-11. OUTx Bits**

OUTx Bit	Complementary Mode	Independent Mode
OUT1	1 — PWM1 is active 0 — PWM1 is inactive	1 — PWM1 is active 0 — PWM1 is inactive
OUT2	1 — PWM2 is complement of PWM 1 0 — PWM2 is inactive	1 — PWM2 is active 0 — PWM2 is inactive
OUT3	1 — PWM3 is active 0 — PWM3 is inactive	1 — PWM3 is active 0 — PWM3 is inactive
OUT4	1 — PWM4 is complement of PWM 3 0 — PWM4 is inactive	1 — PWM4 is active 0 — PWM4 is inactive
OUT5	1 — PWM5 is active 0 — PWM5 is inactive	1 — PWM5 is active 0 — PWM5 is inactive
OUT6	1 — PWM 6 is complement of PWM 5 0 — PWM6 is inactive	1 — PWM6 is active 0 — PWM6 is inactive

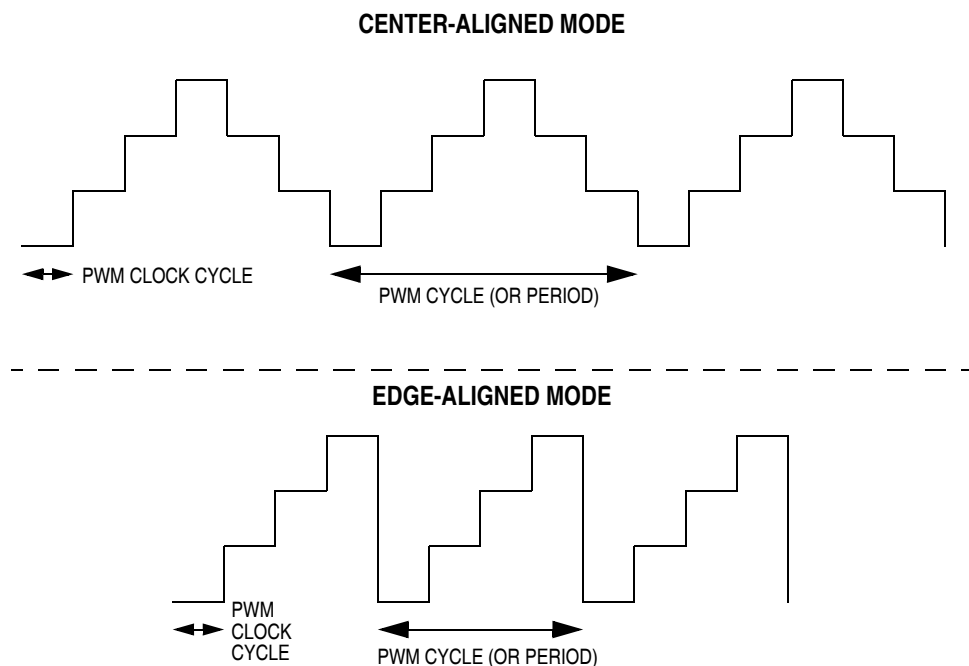
## 9.12 PWM Glossary

**CPU Cycle** — One internal bus cycle ( $1/f_{op}$ )

**PWM Clock Cycle (or Period)** — One tick of the PWM counter ( $1/f_{op}$  with no prescaler). See [Figure 9-51](#).

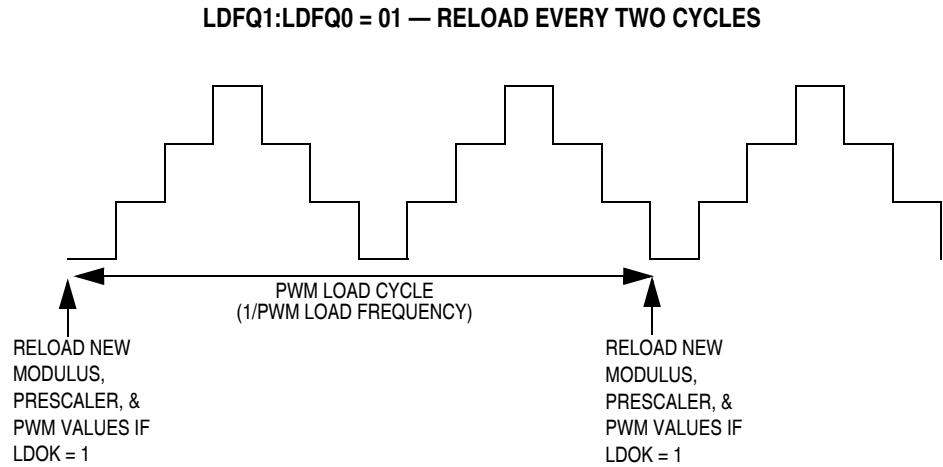
### PWM Cycle (or Period)

- Center-aligned mode: The time it takes the PWM counter to count up and count down (modulus\* $2/f_{op}$  assuming no prescaler). See [Figure 9-51](#).
- Edge-aligned mode: The time it takes the PWM counter to count up (Modulus/ $f_{op}$ ). See [Figure 9-51](#).



**Figure 9-51. PWM Clock Cycle and PWM Cycle Definitions**

**PWM Load Frequency** — Frequency at which new PWM parameters get loaded into the PWM. See [Figure 9-52](#).



**Figure 9-52. PWM Load Cycle/Frequency Definition**



## Section 10. Monitor ROM (MON)

### 10.1 Contents

10.2	Introduction .....	191
10.3	Features .....	192
10.4	Functional Description .....	192
10.4.1	Entering Monitor Mode .....	194
10.4.2	Data Format .....	195
10.4.3	Echoing .....	196
10.4.4	Break Signal .....	196
10.4.5	Commands .....	197
10.4.6	Baud Rate .....	200

### 10.2 Introduction

This section describes the monitor ROM (MON08, Version B). The monitor ROM allows complete testing of the MCU through a single-wire interface with a host computer.

### 10.3 Features

Features of the monitor ROM include the following:

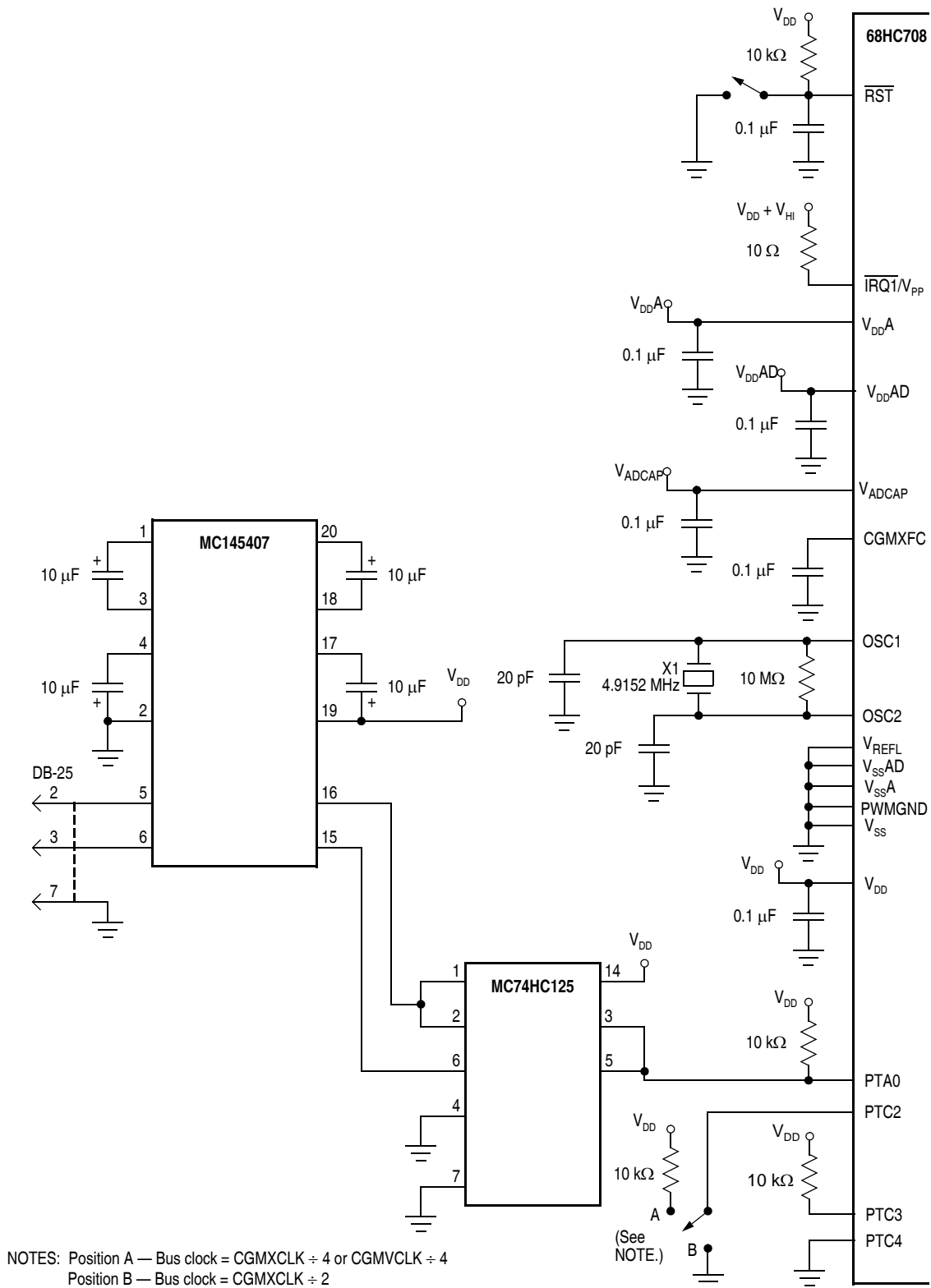
- Normal user-mode pin functionality
- One pin dedicated to serial communication between monitor ROM and host computer
- Standard mark/space non-return-to-zero (NRZ) communication with host computer
- 4800 baud–28.8 kbaud communication with host computer
- Execution of code in RAM or ROM
- (E)EPROM/OTPROM programming

### 10.4 Functional Description

The monitor ROM receives and executes commands from a host computer. [Figure 10-1](#) shows a sample circuit used to enter monitor mode and communicate with a host computer via a standard RS-232 interface.

Simple monitor commands can access any memory address. In monitor mode, the MCU can execute host-computer code in RAM while all MCU pins retain normal operating mode functions. All communication between the host computer and the MCU is through the PTA0 pin. A level-shifting and multiplexing interface is required between PTA0 and the host computer. PTA0 is used in a wired-OR configuration and requires a pull-up resistor.





**Figure 10-1. Monitor Mode Circuit**

## 10.4.1 Entering Monitor Mode

**Table 10-1** shows the pin conditions for entering monitor mode.

**Table 10-1. Mode Selection**

$\overline{\text{IRQ1}}/\text{V}_{\text{PP}}$ Pin	PTC3 Pin	PTC4 Pin	PTA0 Pin	PTC2 Pin	Mode	CGMOUT	Bus Frequency
$V_{\text{DD}} + V_{\text{HI}}$	1	0	1	1	Monitor	$\frac{\text{CGMXCLK}}{2}$ or $\frac{\text{CGMVCLK}}{2}$	$\frac{\text{CGMOUT}}{2}$
$V_{\text{DD}} + V_{\text{HI}}$	1	0	1	0	Monitor	CGMXCLK	$\frac{\text{CGMOUT}}{2}$

Enter monitor mode by either:

- Executing a software interrupt instruction (SWI) or
- Applying a logic 0 and then a logic 1 to the  $\overline{\text{RST}}$  pin.

The MCU sends a break signal (10 consecutive logic 0s) to the host computer, indicating that it is ready to receive a command. The break signal also provides a timing reference to allow the host to determine the necessary baud rate.

Monitor mode uses alternate vectors for reset, SWI, and break interrupt. The alternate vectors are in the \$FE page instead of the \$FF page and allow code execution from the internal monitor firmware instead of user code. The COP module is disabled in monitor mode as long as  $V_{\text{DD}} + V_{\text{HI}}$  is applied to either the  $\overline{\text{IRQ1}}/\text{V}_{\text{PP}}$  pin or the  $\overline{\text{RST}}$  pin. (See [Section 7. System Integration Module \(SIM\)](#) for more information on modes of operation.)

**NOTE:** *Holding the PTC2 pin low when entering monitor mode causes a bypass of a divide-by-two stage at the oscillator. The CGMOUT frequency is equal to the CGMXCLK frequency, and the OSC1 input directly generates internal bus clocks. In this case, the OSC1 signal must have a 50% duty cycle at maximum bus frequency.*

**Table 10-2** is a summary of the differences between user mode and monitor mode.

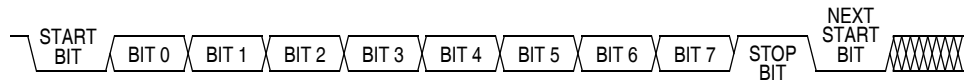
**Table 10-2. Mode Differences**

Modes	Functions						
	COP	Reset Vector High	Reset Vector Low	Break Vector High	Break Vector Low	SWI Vector High	SWI Vector Low
User	Enabled	\$FFFE	\$FFFF	\$FFFC	\$FFFD	\$FFFC	\$FFFD
Monitor	Disabled <sup>(1)</sup>	\$FEFE	\$FEFF	\$FEFC	\$FEFD	\$FEFC	\$FEFD

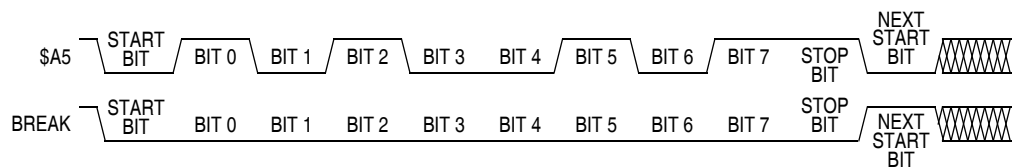
1. If the high voltage ( $V_{DD} + V_{HI}$ ) is removed from the  $\overline{IRQ1}/V_{PP}$  pin or the  $\overline{RST}$  pin, the SIM asserts its COP enable output. The COP is a mask option enabled or disabled by the COPD bit in the mask option register.

### 10.4.2 Data Format

Communication with the monitor ROM is in standard non-return-to-zero (NRZ) mark/space data format. (See [Figure 10-2](#) and [Figure 10-3](#).)



**Figure 10-2. Monitor Data Format**

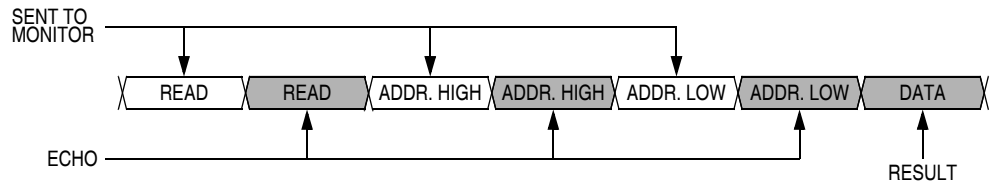


**Figure 10-3. Sample Monitor Waveforms**

The data transmit and receive rate can be anywhere from 4800 baud to 28.8 kbaud. Transmit and receive baud rates must be identical.

## 10.4.3 Echoing

As shown in [Figure 10-4](#), the monitor ROM immediately echoes each received byte back to the PTA0 pin for error checking.

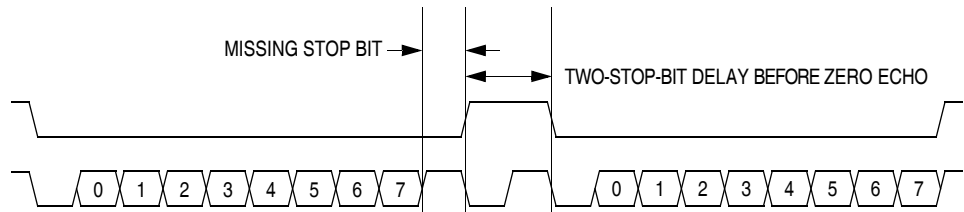


**Figure 10-4. Read Transaction**

Any result of a command appears after the echo of the last byte of the command.

## 10.4.4 Break Signal

A start bit followed by nine low bits is a break signal. (See [Figure 10-5](#).) When the monitor receives a break signal, it drives the PTA0 pin high for the duration of two bits before echoing the break signal.



**Figure 10-5. Break Transaction**

## 10.4.5 Commands

The monitor ROM uses the following commands:

- READ (read memory)
- WRITE (write memory)
- IREAD (indexed read)
- IWRITE (indexed write)
- READSP (read stack pointer)
- RUN (run user program)

**Table 10-3. READ (Read Memory) Command**

Description	Read byte from memory
Operand	Specifies 2-byte address in high byte:low byte order
Data Returned	Returns contents of specified address
Opcode	\$4A
<p>Command Sequence</p>	

**Table 10-4. WRITE (Write Memory) Command**

Description	Write byte to memory
Operand	Specifies 2-byte address in high byte:low byte order; low byte followed by data byte
Data Returned	None
Opcode	\$49
<p>Command Sequence</p>	

**Table 10-5. IREAD (Indexed Read) Command**

Description	Read next 2 bytes in memory from last address accessed
Operand	Specifies 2-byte address in high byte:low byte order
Data Returned	Returns contents of next two addresses
Opcode	\$1A
<p>Command Sequence</p>	

**Table 10-6. IWRITE (Indexed Write) Command**

Description	Write to last address accessed + 1
Operand	Specifies single data byte
Data Returned	None
Opcode	\$19
Command Sequence	
<p>The diagram shows a sequence of four bytes: IWRITE, IWRITE, DATA, and DATA. An arrow labeled 'SENT TO MONITOR' points to the first IWRITE and the first DATA. An arrow labeled 'ECHO' points to the second IWRITE and the second DATA.</p>	

**NOTE:** A sequence of IREAD or IWRITE commands can sequentially access a block of memory over the full 64-Kbyte memory map.

**Table 10-7. READSP (Read Stack Pointer) Command**

Description	Reads stack pointer
Operand	None
Data Returned	Returns stack pointer in high byte:low byte order
Opcode	\$0C
Command Sequence	
<p>The diagram shows a sequence of four bytes: READSP, READSP, SP HIGH, and SP LOW. An arrow labeled 'SENT TO MONITOR' points to the first READSP. An arrow labeled 'ECHO' points to the second READSP. An arrow labeled 'RESULT' points to the SP HIGH and SP LOW bytes.</p>	

**Table 10-8. RUN (Run User Program) Command**

Description	Executes RTI instruction
Operand	None
Data Returned	None
Opcode	\$28
Command Sequence	

## 10.4.6 Baud Rate

With a 4.9152-MHz crystal and the PTC2 pin at logic 1 during reset, data is transferred between the monitor and host at 4800 baud. If the PTC2 pin is at logic 0 during reset, the monitor baud rate is 9600. When the CGM output, CGMOUT, is driven by the PLL, the baud rate is determined by the MUL[7:4] bits in the PLL programming register (PPG). (See [Section 8. Clock Generator Module \(CGM\)](#).)

**Table 10-9. Monitor Baud Rate Selection**

	VCO Frequency Multiplier (N)					
	1	2	3	4	5	6
Monitor Baud Rate	4800	9600	14,400	19,200	24,000	28,800



## Section 11. Timer Interface Module A (TIMA)

### 11.1 Contents

11.2	Introduction	202
11.3	Features	202
11.4	Functional Description	202
11.4.1	TIMA Counter Prescaler	205
11.4.2	Input Capture	205
11.4.3	Output Compare	205
11.4.3.1	Unbuffered Output Compare	206
11.4.3.2	Buffered Output Compare	207
11.4.4	Pulse Width Modulation (PWM)	207
11.4.4.1	Unbuffered PWM Signal Generation	209
11.4.4.2	Buffered PWM Signal Generation	210
11.4.4.3	PWM Initialization	210
11.5	Interrupts	212
11.6	Wait Mode	212
11.7	TIMA During Break Interrupts	213
11.8	I/O Signals	213
11.8.1	TIMA Clock Pin (PTE0/TCLKA)	213
11.8.2	TIMA Channel I/O Pins (PTE1/TCH0A:PTE2/TCH1A)	214
11.9	I/O Registers	214
11.9.1	TIMA Status and Control Register	215
11.9.2	TIMA Counter Registers	217
11.9.3	TIMA Counter Modulo Registers	218
11.9.4	TIMA Channel Status and Control Registers	219
11.9.5	TIMA Channel Registers	223

### 11.2 Introduction

This section describes the timer interface module (TIM2, Version B). The TIMA is a two-channel timer that provides a timing reference with input capture, output compare, and pulse-width-modulation functions. [Figure 11-1](#) is a block diagram of the TIM.

**NOTE:** *Timer interface module A (TIMA) is only available in the 64-pin quad flat package.*

### 11.3 Features

Features of the TIMA include the following:

- Two input capture/output compare channels
  - Rising-edge, falling-edge, or any-edge input capture trigger
  - Set, clear, or toggle output compare action
- Buffered and unbuffered pulse width modulation (PWM) signal generation
- Programmable TIMA clock input
  - Seven-frequency internal bus clock prescaler selection
  - External TIMA clock input (4-MHz maximum frequency)
- Free-running or modulo up-count operation
- Toggle any channel pin on overflow
- TIMA counter stop and reset bits
- Modular architecture expandable to eight channels

### 11.4 Functional Description

[Figure 11-1](#) shows the structure of the TIMA. The central component of the TIMA is the 16-bit TIMA counter that can operate as a free-running counter or a modulo up-counter. The TIMA counter provides the timing reference for the input capture and output compare functions. The TIMA counter modulo registers, TAMODH:TAMODL, control the modulo value

of the TIMA counter. Software can read the TIMA counter value at any time without affecting the counting sequence.

The two TIMA channels are programmable independently as input capture or output compare channels.

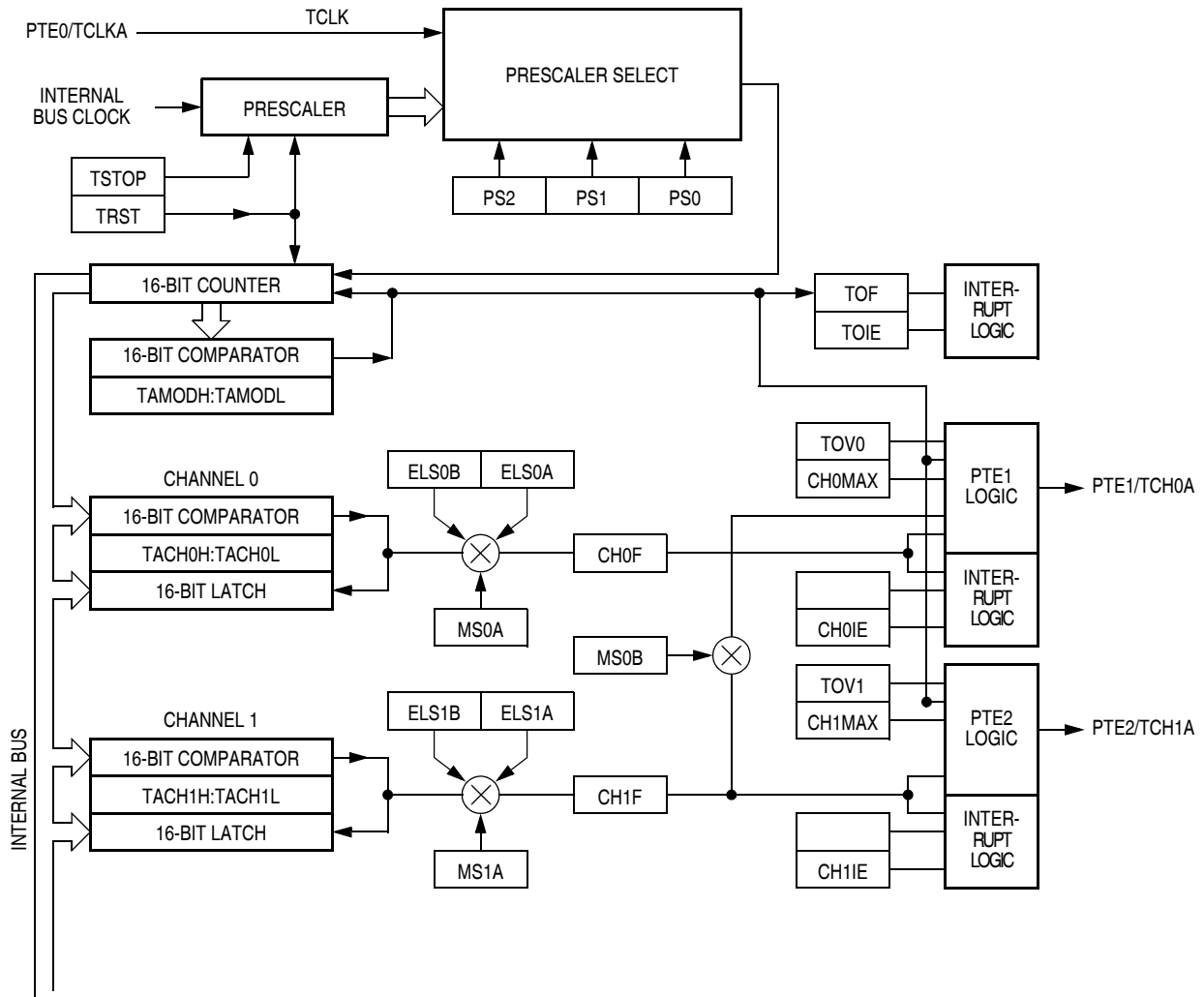



Figure 11-1. TIMA Block Diagram

# Timer Interface Module A (TIMA)

Addr.	Name	Bit 7	6	5	4	3	2	1	Bit 0	
\$000C	Timer A Status and Control Register (TASC)	Read:	TOF	TOIE	TSTOP	0	0	PS2	PS1	PS0
		Write:	0			TRST				
		Reset:	0	0	1	0	0	0	0	0
\$000D	Timer A Counter Register High (TACNTH)	Read:	Bit 15	14	13	12	11	10	9	Bit 8
		Write:								
		Reset:	0	0	0	0	0	0	0	0
\$000E	Timer A Counter Register Low (TACNTL)	Read:	Bit 7	6	5	4	3	2	1	Bit 0
		Write:								
		Reset:	0	0	0	0	0	0	0	0
\$000F	Timer A Modulo Register High (TAMODH)	Read:	Bit 15	14	13	12	11	10	9	Bit 8
		Write:								
		Reset:	1	1	1	1	1	1	1	1
\$0010	Timer A Modulo Register Low (TAMODL)	Read:	Bit 7	6	5	4	3	2	1	Bit 0
		Write:								
		Reset:	1	1	1	1	1	1	1	1
\$0011	Timer A Channel 0 Status and Control Register (TASC0)	Read:	CH0F	CH0IE	MS0B	MS0A	ELS0B	ELS0A	TOV0	CH0MAX
		Write:	0							
		Reset:	0	0	0	0	0	0	0	0
\$0012	Timer A Channel 0 Register High (TACH0H)	Read:	Bit 15	14	13	12	11	10	9	Bit 8
		Write:								
		Reset:	Indeterminate after reset							
\$0013	Timer A Channel 0 Register Low (TACH0L)	Read:	Bit 7	6	5	4	3	2	1	Bit 0
		Write:								
		Reset:	Indeterminate after reset							
\$0014	Timer A Channel 1 Status and Control Register (TASC1)	Read:	CH1F	CH1IE	0	MS1A	ELS1B	ELS1A	TOV1	CH1MAX
		Write:	0							
		Reset:	0	0	0	0	0	0	0	0

= Unimplemented

**Figure 11-2. TIMA I/O Register Summary**

Addr.	Name	Bit 7	6	5	4	3	2	1	Bit 0	
\$0015	Timer A Channel 1 Register High (TACH1H)	Read:	Bit 15	14	13	12	11	10	9	Bit 8
		Write:								
		Reset:	Indeterminate after reset							
\$0016	Timer A Channel 1 Register Low (TACH1L)	Read:	Bit 7	6	5	4	3	2	1	Bit 0
		Write:								
		Reset:	Indeterminate after reset							
			= Unimplemented							

**Figure 11-2. TIMA I/O Register Summary (Continued)**

### 11.4.1 TIMA Counter Prescaler

The TIMA clock source can be one of the seven prescaler outputs or the TIMA clock pin, PTE0/TCLKA. The prescaler generates seven clock rates from the internal bus clock. The prescaler select bits, PS[2:0], in the TIMA status and control register select the TIMA clock source.

### 11.4.2 Input Capture

With the input capture function, the TIMA can capture the time at which an external event occurs. When an active edge occurs on the pin of an input capture channel, the TIMA latches the contents of the TIMA counter into the TIMA channel registers, TACHxH:TACHxL. The polarity of the active edge is programmable. Input captures can generate TIM CPU interrupt requests.

### 11.4.3 Output Compare

With the output compare function, the TIMA can generate a periodic pulse with a programmable polarity, duration, and frequency. When the counter reaches the value in the registers of an output compare channel, the TIMA can set, clear, or toggle the channel pin. Output compares can generate TIM CPU interrupt requests.

### 11.4.3.1 Unbuffered Output Compare

Any output compare channel can generate unbuffered output compare pulses as described in [11.4.3 Output Compare](#). The pulses are unbuffered because changing the output compare value requires writing the new value over the old value currently in the TIMA channel registers.

An unsynchronized write to the TIMA channel registers to change an output compare value could cause incorrect operation for up to two counter overflow periods. For example, writing a new value before the counter reaches the old value but after the counter reaches the new value prevents any compare during that counter overflow period. Also, using a TIMA overflow interrupt routine to write a new, smaller output compare value may cause the compare to be missed. The TIMA may pass the new value before it is written.

Use the following methods to synchronize unbuffered changes in the output compare value on channel x:

- When changing to a smaller value, enable channel x output compare interrupts and write the new value in the output compare interrupt routine. The output compare interrupt occurs at the end of the current output compare pulse. The interrupt routine has until the end of the counter overflow period to write the new value.
- When changing to a larger output compare value, enable channel x TIMA overflow interrupts and write the new value in the TIMA overflow interrupt routine. The TIMA overflow interrupt occurs at the end of the current counter overflow period. Writing a larger value in an output compare interrupt routine (at the end of the current pulse) could cause two output compares to occur in the same counter overflow period.

### 11.4.3.2 Buffered Output Compare

Channels 0 and 1 can be linked to form a buffered output compare channel whose output appears on the PTE1/TCH0A pin. The TIMA channel registers of the linked pair alternately control the output.

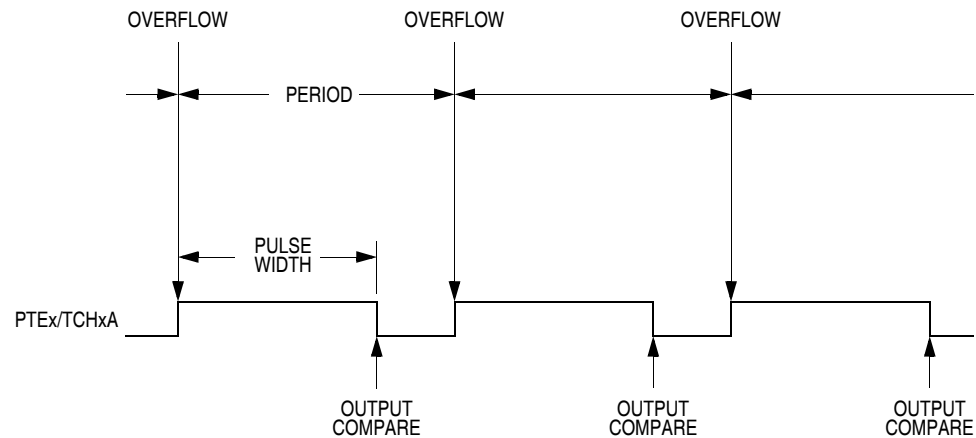
Setting the MS0B bit in TIMA channel 0 status and control register (TASC0) links channel 0 and channel 1. The output compare value in the TIMA channel 0 registers initially controls the output on the PTE1/TCH0A pin. Writing to the TIMA channel 1 registers enables the TIMA channel 1 registers to synchronously control the output after the TIMA overflows. At each subsequent overflow, the TIMA channel registers (0 or 1) that control the output are the ones written to last. TASC0 controls and monitors the buffered output compare function, and TIMA channel 1 status and control register (TASC1) is unused. While the MS0B bit is set, the channel 1 pin, PTE2/TCH1A, is available as a general-purpose I/O pin.

**NOTE:** *In buffered output compare operation, do not write new output compare values to the currently active channel registers. Writing to the active channel registers is the same as generating unbuffered output compares.*

### 11.4.4 Pulse Width Modulation (PWM)

By using the toggle-on-overflow feature with an output compare channel, the TIMA can generate a PWM signal. The value in the TIMA counter modulo registers determines the period of the PWM signal. The channel pin toggles when the counter reaches the value in the TIMA counter modulo registers. The time between overflows is the period of the PWM signal.

As [Figure 11-3](#) shows, the output compare value in the TIMA channel registers determines the pulse width of the PWM signal. The time between overflow and output compare is the pulse width. Program the TIMA to clear the channel pin on output compare if the state of the PWM pulse is logic 1. Program the TIMA to set the pin if the state of the PWM pulse is logic 0.



**Figure 11-3. PWM Period and Pulse Width**

The value in the TIMA counter modulo registers and the selected prescaler output determines the frequency of the PWM output. The frequency of an 8-bit PWM signal is variable in 256 increments. Writing \$00FF (255) to the TIMA counter modulo registers produces a PWM period of 256 times the internal bus clock period if the prescaler select value is 000 (see [11.9.1 TIMA Status and Control Register](#)).

The value in the TIMA channel registers determines the pulse width of the PWM output. The pulse width of an 8-bit PWM signal is variable in 256 increments. Writing \$0080 (128) to the TIMA channel registers produces a duty cycle of 128/256 or 50%.



#### 11.4.4.1 Unbuffered PWM Signal Generation

Any output compare channel can generate unbuffered PWM pulses as described in [11.4.4 Pulse Width Modulation \(PWM\)](#). The pulses are unbuffered because changing the pulse width requires writing the new pulse width value over the old value currently in the TIMA channel registers.

An unsynchronized write to the TIMA channel registers to change a pulse width value could cause incorrect operation for up to two PWM periods. For example, writing a new value before the counter reaches the old value but after the counter reaches the new value prevents any compare during that PWM period. Also, using a TIMA overflow interrupt routine to write a new, smaller pulse width value may cause the compare to be missed. The TIMA may pass the new value before it is written.

Use the following methods to synchronize unbuffered changes in the PWM pulse width on channel x:

- When changing to a shorter pulse width, enable channel x output compare interrupts and write the new value in the output compare interrupt routine. The output compare interrupt occurs at the end of the current pulse. The interrupt routine has until the end of the PWM period to write the new value.
- When changing to a longer pulse width, enable channel x TIMA overflow interrupts and write the new value in the TIMA overflow interrupt routine. The TIMA overflow interrupt occurs at the end of the current PWM period. Writing a larger value in an output compare interrupt routine (at the end of the current pulse) could cause two output compares to occur in the same PWM period.

**NOTE:** *In PWM signal generation, do not program the PWM channel to toggle on output compare. Toggling on output compare prevents reliable 0% duty cycle generation and removes the ability of the channel to self-correct in the event of software error or noise. Toggling on output compare also can cause incorrect PWM signal generation when changing the PWM pulse width to a new, much larger value.*

### 11.4.4.2 Buffered PWM Signal Generation

Channels 0 and 1 can be linked to form a buffered PWM channel whose output appears on the PTE1/TCH0A pin. The TIMA channel registers of the linked pair alternately control the pulse width of the output.

Setting the MS0B bit in TIMA channel 0 status and control register (TASC0) links channel 0 and channel 1. The TIMA channel 0 registers initially control the pulse width on the PTE1/TCH0A pin. Writing to the TIMA channel 1 registers enables the TIMA channel 1 registers to synchronously control the pulse width at the beginning of the next PWM period. At each subsequent overflow, the TIMA channel registers (0 or 1) that control the pulse width are the ones written to last. TASC0 controls and monitors the buffered PWM function, and TIMA channel 1 status and control register (TASC1) is unused. While the MS0B bit is set, the channel 1 pin, PTE2/TCH1A, is available as a general-purpose I/O pin.

**NOTE:** *In buffered PWM signal generation, do not write new pulse width values to the currently active channel registers. Writing to the active channel registers is the same as generating unbuffered PWM signals.*

### 11.4.4.3 PWM Initialization

To ensure correct operation when generating unbuffered or buffered PWM signals, use the following initialization procedure:

1. In the TIMA status and control register (TASC):
  - a. Stop the TIMA counter by setting the TIMA stop bit, TSTOP.
  - b. Reset the TIMA counter by setting the TIMA reset bit, TRST.
2. In the TIMA counter modulo registers (TAMODH:TAMODL), write the value for the required PWM period.
3. In the TIMA channel x registers (TACHxH:TACHxL), write the value for the required pulse width.

4. In TIMA channel x status and control register (TASCx):
  - a. Write 0:1 (for unbuffered output compare or PWM signals) or 1:0 (for buffered output compare or PWM signals) to the mode select bits, MSxB:MSxA. (See [Table 11-2](#).)
  - b. Write 1 to the toggle-on-overflow bit, TOVx.
  - c. Write 1:0 (to clear output on compare) or 1:1 (to set output on compare) to the edge/level select bits, ELSxB:ELSxA. The output action on compare must force the output to the complement of the pulse width level. (See [Table 11-2](#).)

**NOTE:** *In PWM signal generation, do not program the PWM channel to toggle on output compare. Toggling on output compare prevents reliable 0% duty cycle generation and removes the ability of the channel to self-correct in the event of software error or noise. Toggling on output compare can also cause incorrect PWM signal generation when changing the PWM pulse width to a new, much larger value.*

5. In the TIMA status control register (TASC), clear the TIMA stop bit, TSTOP.

Setting MS0B links channels 0 and 1 and configures them for buffered PWM operation. The TIMA channel 0 registers (TACH0H:TACH0L) initially control the buffered PWM output. TIMA status control register 0 (TASCRO) controls and monitors the PWM signal from the linked channels. MS0B takes priority over MS0A.

Clearing the toggle-on-overflow bit, TOVx, inhibits output toggles on TIMA overflows. Subsequent output compares try to force the output to a state it is already in and have no effect. The result is a 0% duty cycle output.

Setting the channel x maximum duty cycle bit (CHxMAX) and clearing the TOVx bit generates a 100% duty cycle output. (See [11.9.4 TIMA Channel Status and Control Registers](#).)

### 11.5 Interrupts

The following TIMA sources can generate interrupt requests:

- TIMA overflow flag (TOF) — The TOF bit is set when the TIMA counter value rolls over to \$0000 after matching the value in the TIMA counter modulo registers. The TIMA overflow interrupt enable bit, TOIE, enables TIMA overflow CPU interrupt requests. TOF and TOIE are in the TIMA status and control register.
- TIMA channel flags (CH1F:CH0F) — The CHxF bit is set when an input capture or output compare occurs on channel x. Channel x TIM CPU interrupt requests are controlled by the channel x interrupt enable bit, CHxIE. Channel x TIM CPU interrupt requests are enabled when CHxIE = 1. CHxF and CHxIE are in the TIMA channel x status and control register.

### 11.6 Wait Mode

The WAIT instruction puts the MCU in low-power-consumption standby mode.

The TIMA remains active after the execution of a WAIT instruction. In wait mode the TIMA registers are not accessible by the CPU. Any enabled CPU interrupt request from the TIMA can bring the MCU out of wait mode.

If TIMA functions are not required during wait mode, reduce power consumption by stopping the TIMA before executing the WAIT instruction.

## 11.7 TIMA During Break Interrupts

A break interrupt stops the TIMA counter.

The system integration module (SIM) controls whether status bits in other modules can be cleared during the break state. The BCFE bit in the SIM break flag control register (SBFCR) enables software to clear status bits during the break state. (See [7.7.4 SIM Break Flag Control Register](#).)

To allow software to clear status bits during a break interrupt, write a logic 1 to the BCFE bit. If a status bit is cleared during the break state, it remains cleared when the MCU exits the break state.

To protect status bits during the break state, write a logic 0 to the BCFE bit. With BCFE at logic 0 (its default state), software can read and write I/O registers during the break state without affecting status bits. Some status bits have a two-step read/write clearing procedure. If software does the first step on such a bit before the break, the bit cannot change during the break state as long as BCFE is at logic 0. After the break, doing the second step clears the status bit.

## 11.8 I/O Signals

Port E shares three of its pins with the TIMA. PTE0/TCLKA is an external clock input to the TIMA prescaler. The two TIMA channel I/O pins are PTE1/TCH0A and PTE2/TCH1A.

### 11.8.1 TIMA Clock Pin (PTE0/TCLKA)

PTE0/TCLKA is an external clock input that can be the clock source for the TIMA counter instead of the prescaled internal bus clock. Select the PTE0/TCLKA input by writing logic 1s to the three prescaler select bits,

PS[2:0]. (See [11.9.1 TIMA Status and Control Register](#).) The minimum TCLK pulse width,  $TCLK_{L\text{MIN}}$  or  $TCLK_{H\text{MIN}}$ , is:

$$\frac{1}{\text{bus frequency}} + t_{\text{SU}}$$

The maximum TCLK frequency is:

$$\text{bus frequency} \div 2$$

PTE0/TCLKA is available as a general-purpose I/O pin when not used as the TIMA clock input. When the PTE0/TCLKA pin is the TIMA clock input, it is an input regardless of the state of the DDRE0 bit in data direction register E.

### 11.8.2 TIMA Channel I/O Pins (PTE1/TCH0A:PTE2/TCH1A)

Each channel I/O pin is programmable independently as an input capture pin or an output compare pin. PTE1/TCH0A and PTE2/TCH1A can be configured as buffered output compare or buffered PWM pins.

## 11.9 I/O Registers

The following I/O registers control and monitor operation of the TIM:

- TIMA status and control register (TASC)
- TIMA control registers (TACNTH:TACNTL)
- TIMA counter modulo registers (TAMODH:TAMODL)
- TIMA channel status and control registers (TASC0 and TASC1)
- TIMA channel registers (TACH0H:TACH0L and TACH1H:TACH1L)


### 11.9.1 TIMA Status and Control Register

The TIMA status and control register does the following:

- Enables TIMA overflow interrupts
- Flags TIMA overflows
- Stops the TIMA counter
- Resets the TIMA counter
- Prescales the TIMA counter clock

Address: \$000C

	Bit 7	6	5	4	3	2	1	Bit 0
Read:	TOF	TOIE	TSTOP	0	0	PS2	PS1	PS0
Write:	0			TRST				
Reset:	0	0	1	0	0	0	0	0

 = Unimplemented

**Figure 11-4. TIMA Status and Control Register (TASC)**

#### TOF — TIMA Overflow Flag Bit

This read/write flag is set when the TIMA counter resets to \$0000 after reaching the modulo value programmed in the TIMA counter modulo registers. Clear TOF by reading the TIMA status and control register when TOF is set and then writing a logic 0 to TOF. If another TIMA overflow occurs before the clearing sequence is complete, then writing logic 0 to TOF has no effect. Therefore, a TOF interrupt request cannot be lost due to inadvertent clearing of TOF. Reset clears the TOF bit. Writing a logic 1 to TOF has no effect.

1 = TIMA counter has reached modulo value

0 = TIMA counter has not reached modulo value

#### TOIE — TIMA Overflow Interrupt Enable Bit

This read/write bit enables TIMA overflow interrupts when the TOF bit becomes set. Reset clears the TOIE bit.

1 = TIMA overflow interrupts enabled

0 = TIMA overflow interrupts disabled

## TSTOP — TIMA Stop Bit

This read/write bit stops the TIMA counter. Counting resumes when TSTOP is cleared. Reset sets the TSTOP bit, stopping the TIMA counter until software clears the TSTOP bit.

- 1 = TIMA counter stopped
- 0 = TIMA counter active

**NOTE:** Do not set the TSTOP bit before entering wait mode if the TIMA is required to exit wait mode.

## TRST — TIMA Reset Bit

Setting this write-only bit resets the TIMA counter and the TIMA prescaler. Setting TRST has no effect on any other registers. Counting resumes from \$0000. TRST is cleared automatically after the TIMA counter is reset and always reads as logic 0. Reset clears the TRST bit.

- 1 = Prescaler and TIMA counter cleared
- 0 = No effect

**NOTE:** Setting the TSTOP and TRST bits simultaneously stops the TIMA counter at a value of \$0000.

## PS[2:0] — Prescaler Select Bits

These read/write bits select either the PTE0/TCLKA pin or one of the seven prescaler outputs as the input to the TIMA counter as [Table 11-1](#) shows. Reset clears the PS[2:0] bits.

**Table 11-1. Prescaler Selection**

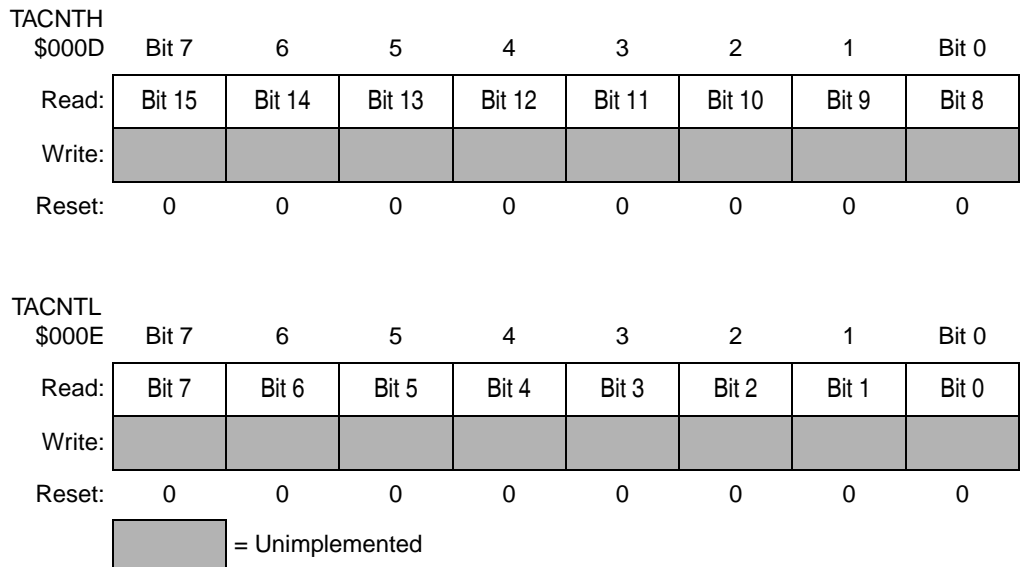
PS[2:0]	TIMA Clock Source
000	Internal Bus Clock ÷ 1
001	Internal Bus Clock ÷ 2
010	Internal Bus Clock ÷ 4
011	Internal Bus Clock ÷ 8
100	Internal Bus Clock ÷ 16
101	Internal Bus Clock ÷ 32
110	Internal Bus Clock ÷ 64
111	PTE0/TCLKA



### 11.9.2 TIMA Counter Registers

The two read-only TIMA counter registers contain the high and low bytes of the value in the TIMA counter. Reading the high byte (TACNTH) latches the contents of the low byte (TACNTL) into a buffer. Subsequent reads of TACNTH do not affect the latched TACNTL value until TACNTL is read. Reset clears the TIMA counter registers. Setting the TIMA reset bit (TRST) also clears the TIMA counter registers.

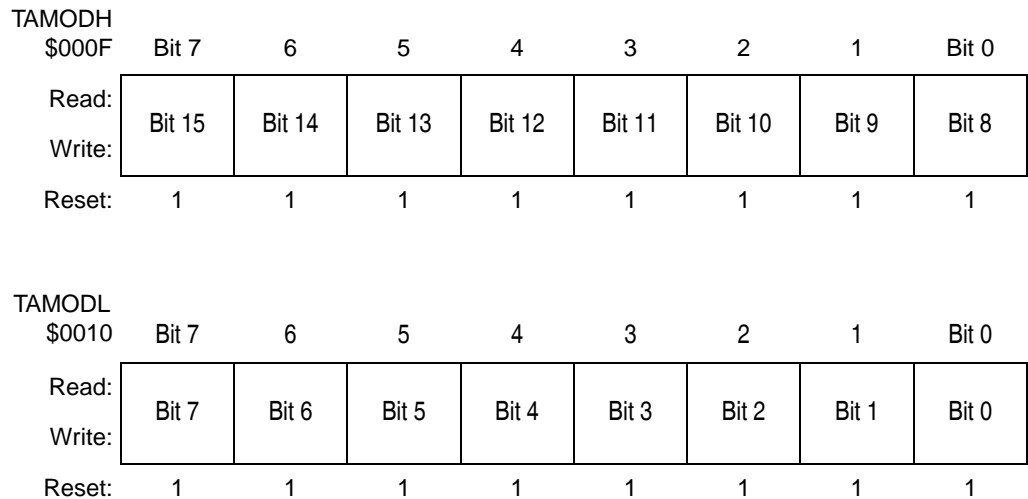
**NOTE:** *If you read TACNTH during a break interrupt, be sure to unlatch TACNTL by reading TACNTL before exiting the break interrupt. Otherwise, TACNTL retains the value latched during the break.*



**Figure 11-5. TIMA Counter Registers (TACNTH:TACNTL)**

## 11.9.3 TIMA Counter Modulo Registers

The read/write TIMA modulo registers contain the modulo value for the TIMA counter. When the TIMA counter reaches the modulo value, the overflow flag (TOF) becomes set, and the TIMA counter resumes counting from \$0000 at the next clock. Writing to the high byte (TAMODH) inhibits the TOF bit and overflow interrupts until the low byte (TAMODL) is written. Reset sets the TIMA counter modulo registers.



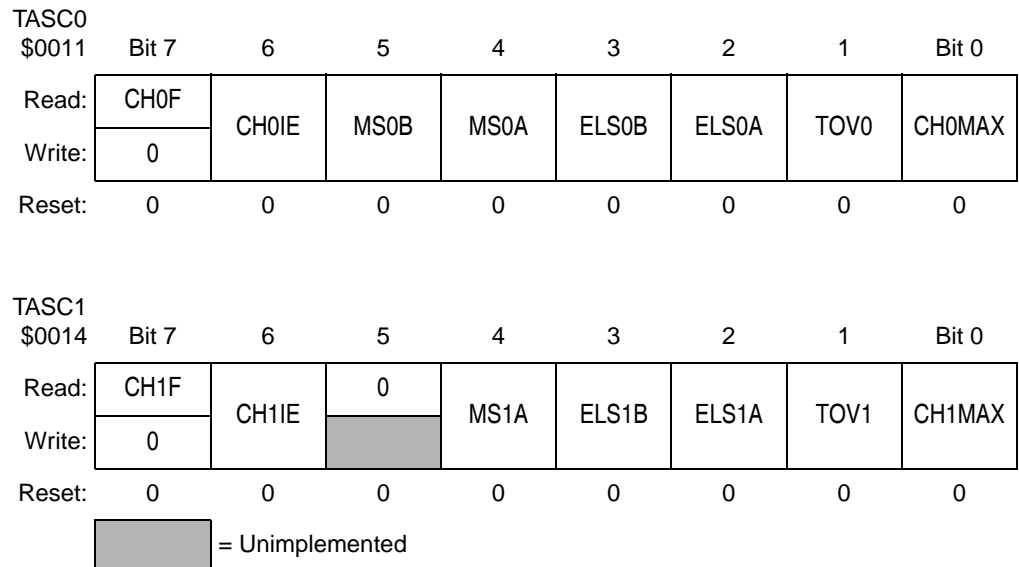
**Figure 11-6. TIMA Counter Modulo Registers (TAMODH:TAMODL)**

**NOTE:** *Reset the TIMA counter before writing to the TIMA counter modulo registers.*

### 11.9.4 TIMA Channel Status and Control Registers

Each of the TIMA channel status and control registers does the following:

- Flags input captures and output compares
- Enables input capture and output compare interrupts
- Selects input capture, output compare, or PWM operation
- Selects high, low, or toggling output on output compare
- Selects rising edge, falling edge, or any edge as the active input capture trigger
- Selects output toggling on TIMA overflow
- Selects 100% PWM duty cycle
- Selects buffered or unbuffered output compare/PWM operation



**Figure 11-7. TIMA Channel Status and Control Registers (TASC0:TASC1)**

### CHxF — Channel x Flag Bit

When channel x is an input capture channel, this read/write bit is set when an active edge occurs on the channel x pin. When channel x is an output compare channel, CHxF is set when the value in the TIMA counter registers matches the value in the TIMA channel x registers.

When TIMA CPU interrupt requests are enabled (CHxIE=1), clear CHxF by reading the TIMA channel x status and control register with CHxF set and then writing a logic 0 to CHxF. If another interrupt request occurs before the clearing sequence is complete, then writing logic 0 to CHxF has no effect. Therefore, an interrupt request cannot be lost due to inadvertent clearing of CHxF.

Reset clears the CHxF bit. Writing a logic 1 to CHxF has no effect.

1 = Input capture or output compare on channel x

0 = No input capture or output compare on channel x

### CHxIE — Channel x Interrupt Enable Bit

This read/write bit enables TIMA CPU interrupt service requests on channel x. Reset clears the CHxIE bit.

1 = Channel x CPU interrupt requests enabled

0 = Channel x CPU interrupt requests disabled

### MSxB — Mode Select Bit B

This read/write bit selects buffered output compare/PWM operation. MSxB exists only in the TIMA channel 0 status and control register.

Setting MS0B disables the channel 1 status and control register and reverts TCH1 to general-purpose I/O.

Reset clears the MSxB bit.

1 = Buffered output compare/PWM operation enabled

0 = Buffered output compare/PWM operation disabled

### MSxA — Mode Select Bit A

When ELSxB:A  $\neq$  00, this read/write bit selects either input capture operation or unbuffered output compare/PWM operation.

See [Table 11-2](#).

1 = Unbuffered output compare/PWM operation

0 = Input capture operation

When ELSxB:A = 00, this read/write bit selects the initial output level of the TCHx pin. (See [Table 11-2](#).) Reset clears the MSxA bit.

1 = Initial output level low

0 = Initial output level high

**NOTE:** Before changing a channel function by writing to the MSxB or MSxA bit, set the TSTOP and TRST bits in the TIMA status and control register (TSC).

#### ELSxB and ELSxA — Edge/Level Select Bits

When channel x is an input capture channel, these read/write bits control the active edge-sensing logic on channel x.

When channel x is an output compare channel, ELSxB and ELSxA control the channel x output behavior when an output compare occurs.

When ELSxB and ELSxA are both clear, channel x is not connected to port E, and pin PTE<sub>x</sub>/TCH<sub>x</sub>A is available as a general-purpose I/O pin. [Table 11-2](#) shows how ELSxB and ELSxA work. Reset clears the ELSxB and ELSxA bits.

**Table 11-2. Mode, Edge, and Level Selection**

MSxB:MSxA	ELSxB:ELSxA	Mode	Configuration
X0	00	Output Preset	Pin under Port Control; Initial Output Level High
X1	00		Pin under Port Control; Initial Output Level Low
00	01	Input Capture	Capture on Rising Edge Only
00	10		Capture on Falling Edge Only
00	11		Capture on Rising or Falling Edge
01	01	Output Compare or PWM	Toggle Output on Compare
01	10		Clear Output on Compare
01	11		Set Output on Compare
1X	01	Buffered Output Compare or Buffered PWM	Toggle Output on Compare
1X	10		Clear Output on Compare
1X	11		Set Output on Compare

## Timer Interface Module A (TIMA)

**NOTE:** Before enabling a TIMA channel register for input capture operation, make sure that the PTE<sub>x</sub>/TACH<sub>x</sub> pin is stable for at least two bus clocks.

### TOV<sub>x</sub> — Toggle-On-Overflow Bit

When channel x is an output compare channel, this read/write bit controls the behavior of the channel x output when the TIMA counter overflows. When channel x is an input capture channel, TOV<sub>x</sub> has no effect. Reset clears the TOV<sub>x</sub> bit.

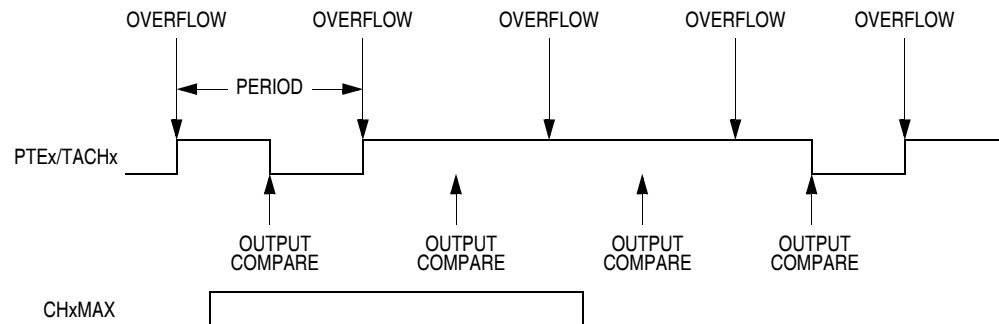
1 = Channel x pin toggles on TIMA counter overflow.

0 = Channel x pin does not toggle on TIMA counter overflow.

**NOTE:** When TOV<sub>x</sub> is set, a TIMA counter overflow takes precedence over a channel x output compare if both occur at the same time.

### CH<sub>x</sub>MAX — Channel x Maximum Duty Cycle Bit

When the TOV<sub>x</sub> bit is at logic 0, setting the CH<sub>x</sub>MAX bit forces the duty cycle of buffered and unbuffered PWM signals to 100%. As [Figure 11-8](#) shows, the CH<sub>x</sub>MAX bit takes effect in the cycle after it is set or cleared. The output stays at the 100% duty cycle level until the cycle after CH<sub>x</sub>MAX is cleared.



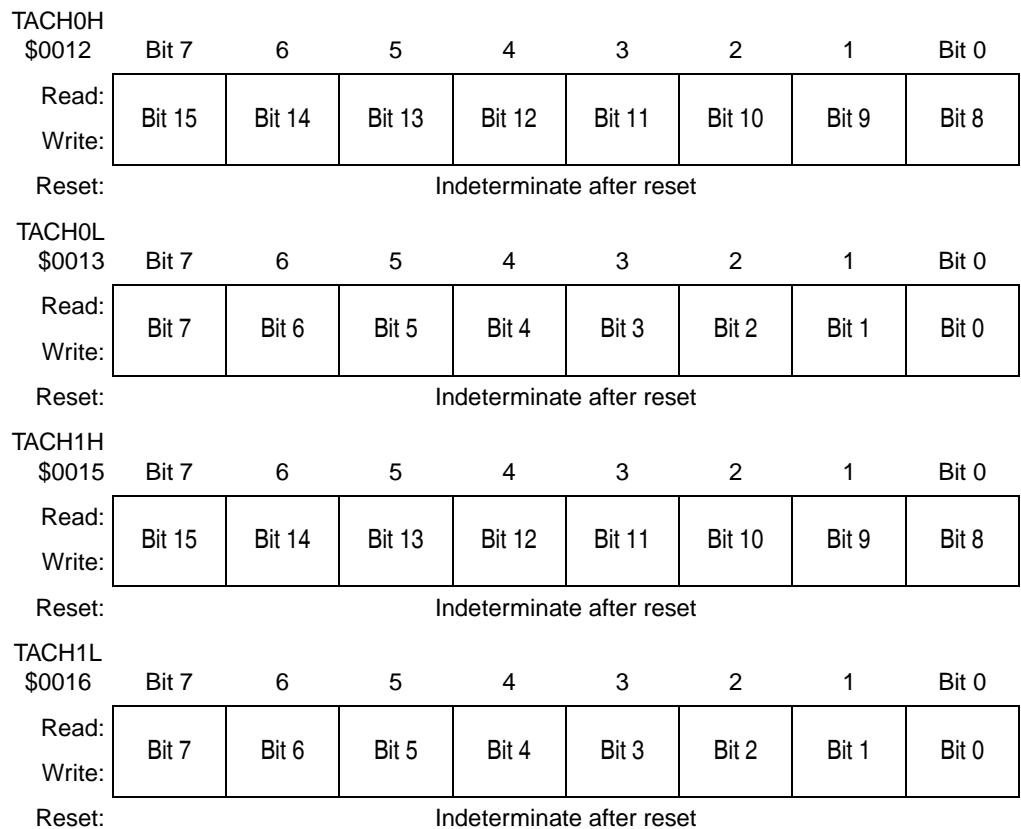
**Figure 11-8. CH<sub>x</sub>MAX Latency**

### 11.9.5 TIMA Channel Registers

These read/write registers contain the captured TIMA counter value of the input capture function or the output compare value of the output compare function. The state of the TIMA channel registers after reset is unknown.

In input capture mode ( $MSxB:MSxA = 0:0$ ), reading the high byte of the TIMA channel x registers (TACHxH) inhibits input captures until the low byte (TACHxL) is read.

In output compare mode ( $MSxB:MSxA \neq 0:0$ ), writing to the high byte of the TIMA channel x registers (TACHxH) inhibits output compares until the low byte (TACHxL) is written.



**Figure 11-9. TIMA Channel Registers (TACH0H/L:TACH1H/L)**





## Section 12. Timer Interface Module B (TIMB)

### 12.1 Contents

12.2	Introduction	226
12.3	Features	226
12.4	Functional Description	226
12.4.1	TIMB Counter Prescaler	230
12.4.2	Input Capture	230
12.4.3	Output Compare	230
12.4.3.1	Unbuffered Output Compare	230
12.4.3.2	Buffered Output Compare	231
12.4.4	Pulse Width Modulation (PWM)	232
12.4.4.1	Unbuffered PWM Signal Generation	233
12.4.4.2	Buffered PWM Signal Generation	234
12.4.4.3	PWM Initialization	235
12.5	Interrupts	237
12.6	Wait Mode	237
12.7	TIMB During Break Interrupts	238
12.8	I/O Signals	238
12.8.1	TIMB Clock Pin (PTE3/TCLKB)	238
12.8.2	TIMB Channel I/O Pins (PTE4/TCH0B:PTE7/TCH3B)	239
12.9	I/O Registers	239
12.9.1	TIMB Status and Control Register	240
12.9.2	TIMB Counter Registers	242
12.9.3	TIMB Counter Modulo Registers	243
12.9.4	TIMB Channel Status and Control Registers	244
12.9.5	TIMB Channel Registers	248

## 12.2 Introduction

This section describes the timer interface module (TIM4, Version B). The TIMB is a four-channel timer that provides a timing reference with input capture, output compare, and pulse-width-modulation functions.

**Figure 12-1** is a block diagram of the TIMB.

## 12.3 Features

Features of the TIMB include:

- Four input capture/output compare channels
  - Rising-edge, falling-edge, or any-edge input capture trigger
  - Set, clear, or toggle output compare action
- Buffered and unbuffered pulse width modulation (PWM) signal generation
- Programmable TIMB clock input
  - Seven-frequency internal bus clock prescaler selection
  - External TIMB clock input (4-MHz maximum frequency)
- Free-running or modulo up-count operation
- Toggle any channel pin on overflow
- TIMB counter stop and reset bits
- Modular architecture expandable to eight channels

## 12.4 Functional Description

**Figure 12-1** shows the structure of the TIMB. The central component of the TIMB is the 16-bit TIMB counter that can operate as a free-running counter or a modulo up-counter. The TIMB counter provides the timing reference for the input capture and output compare functions. The TIMB counter modulo registers, TBMODH:TBMODL, control the modulo value of the TIMB counter. Software can read the TIMB counter value at any time without affecting the counting sequence.

The four TIMB channels are programmable independently as input capture or output compare channels.

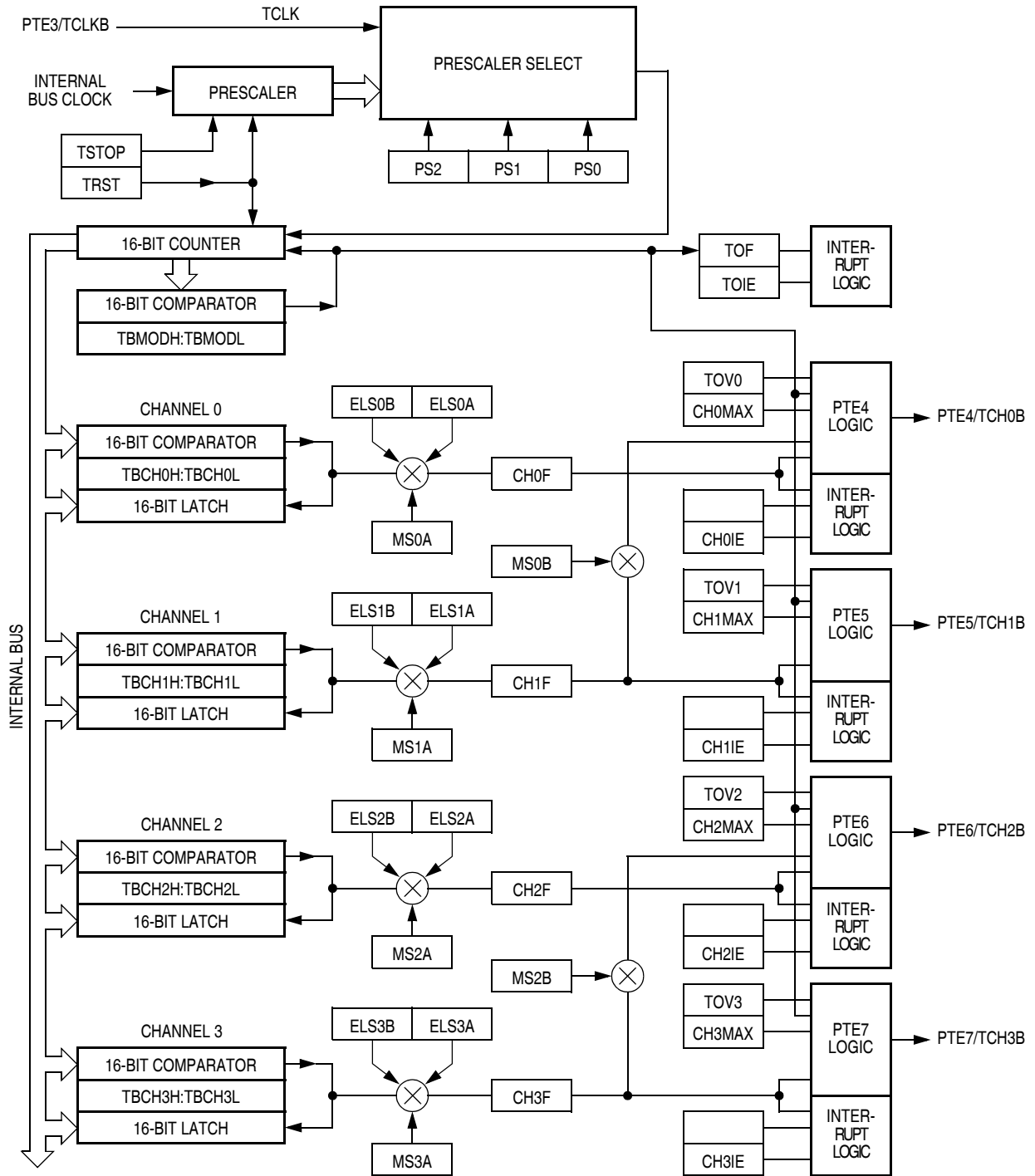


Figure 12-1. TIMB Block Diagram

# Timer Interface Module B (TIMB)

Addr.	Name	Bit 7	6	5	4	3	2	1	Bit 0	
\$003F	Timer B Status and Control Register (TBSC)	Read:	TOF	TOIE	TSTOP	0	0	PS2	PS1	PS0
		Write:	0			TRST				
		Reset:	0	0	0	0	0	0	0	0
\$0040	Timer B Counter Register High (TBCNTH)	Read:	Bit 15	14	13	12	11	10	9	Bit 8
		Write:								
		Reset:	0	0	0	0	0	0	0	0
\$0041	Timer B Counter Register Low (TBCNTL)	Read:	Bit 7	6	5	4	3	2	1	Bit 0
		Write:								
		Reset:	0	0	0	0	0	0	0	0
\$0042	Timer B Modulo Register High (TBMODH)	Read:	Bit 15	14	13	12	11	10	9	Bit 8
		Write:								
		Reset:	1	1	1	1	1	1	1	1
\$0043	Timer B Modulo Register Low (TBMODL)	Read:	Bit 7	6	5	4	3	2	1	Bit 0
		Write:								
		Reset:	1	1	1	1	1	1	1	1
\$0044	Timer B Channel 0 Status and Control Register (TBSC0)	Read:	CH0F	CH0IE	MS0B	MS0A	ELS0B	ELS0A	TOV0	CH0MAX
		Write:	0							
		Reset:	0	0	0	0	0	0	0	0
\$0045	Timer B Channel 0 Register High (TBCH0H)	Read:	Bit 15	14	13	12	11	10	9	Bit 8
		Write:								
		Reset:	Indeterminate after reset							
\$0046	Timer B Channel 0 Register Low (TBCH0L)	Read:	Bit 7	6	5	4	3	2	1	Bit 0
		Write:								
		Reset:	Indeterminate after reset							
\$0047	Timer B Channel 1 Status and Control Register (TBSC1)	Read:	CH1F	CH1IE	0	MS1A	ELS1B	ELS1A	TOV1	CH1MAX
		Write:	0							
		Reset:	0	0	0	0	0	0	0	0

= Unimplemented

**Figure 12-2. TIMB I/O Register Summary**

Addr.	Name	Bit 7	6	5	4	3	2	1	Bit 0	
\$0048	Timer B Channel 1 Register High (TBCH1H)	Read:	Bit 15	14	13	12	11	10	9	Bit 8
		Write:								
		Reset:	Indeterminate after reset							
\$0049	Timer B Channel 1 Register Low (TBCH1L)	Read:	Bit 7	6	5	4	3	2	1	Bit 0
		Write:								
		Reset:	Indeterminate after reset							
\$004A	Timer B Channel 2 Status and Control Register (TBSC2)	Read:	CH2F	CH2IE	MS2B	MS2A	ELS2B	ELS2A	TOV2	CH2MAX
		Write:	0							
		Reset:	0	0	0	0	0	0	0	0
\$004B	Timer B Channel 2 Register High (TBCH2H)	Read:	Bit 15	14	13	12	11	10	9	Bit 8
		Write:								
		Reset:	Indeterminate after reset							
\$004C	Timer B Channel 2 Register Low (TBCH2L)	Read:	Bit 7	6	5	4	3	2	1	Bit 0
		Write:								
		Reset:	Indeterminate after reset							
\$004D	Timer B Channel 3 Status and Control Register (TBSC3)	Read:	CH3F	CH3IE	0	MS3A	ELS3B	ELS3A	TOV3	CH3MAX
		Write:	0							
		Reset:	0	0	0	0	0	0	0	0
\$004E	Timer B Channel 3 Register High (TBCH3H)	Read:	Bit 15	14	13	12	11	10	9	Bit 8
		Write:								
		Reset:	Indeterminate after reset							
\$004F	Timer B Channel 3 Register Low (TBCH3L)	Read:	Bit 7	6	5	4	3	2	1	Bit 0
		Write:								
		Reset:	Indeterminate after reset							

= Unimplemented

**Figure 12-2. TIMB I/O Register Summary**

### 12.4.1 TIMB Counter Prescaler

The TIMB clock source can be one of the seven prescaler outputs or the TIMB clock pin, PTE3/TCLKB. The prescaler generates seven clock rates from the internal bus clock. The prescaler select bits, PS[2:0], in the TIMB status and control register select the TIMB clock source.

### 12.4.2 Input Capture

With the input capture function, the TIMB can capture the time at which an external event occurs. When an active edge occurs on the pin of an input capture channel, the TIMB latches the contents of the TIMB counter into the TIMB channel registers, TBCHxH:TBCHxL. The polarity of the active edge is programmable. Input captures can generate TIM CPU interrupt requests.

### 12.4.3 Output Compare

With the output compare function, the TIMB can generate a periodic pulse with a programmable polarity, duration, and frequency. When the counter reaches the value in the registers of an output compare channel, the TIMB can set, clear, or toggle the channel pin. Output compares can generate TIM CPU interrupt requests.

#### 12.4.3.1 Unbuffered Output Compare

Any output compare channel can generate unbuffered output compare pulses as described in [12.4.3 Output Compare](#). The pulses are unbuffered because changing the output compare value requires writing the new value over the old value currently in the TIMB channel registers.

An unsynchronized write to the TIMB channel registers to change an output compare value could cause incorrect operation for up to two counter overflow periods. For example, writing a new value before the counter reaches the old value but after the counter reaches the new value prevents any compare during that counter overflow period. Also, using a TIMB overflow interrupt routine to write a new, smaller output

compare value may cause the compare to be missed. The TIMB may pass the new value before it is written.

Use the following methods to synchronize unbuffered changes in the output compare value on channel x:

- When changing to a smaller value, enable channel x output compare interrupts and write the new value in the output compare interrupt routine. The output compare interrupt occurs at the end of the current output compare pulse. The interrupt routine has until the end of the counter overflow period to write the new value.
- When changing to a larger output compare value, enable channel x TIMB overflow interrupts and write the new value in the TIMB overflow interrupt routine. The TIMB overflow interrupt occurs at the end of the current counter overflow period. Writing a larger value in an output compare interrupt routine (at the end of the current pulse) could cause two output compares to occur in the same counter overflow period.

### 12.4.3.2 Buffered Output Compare

Channels 0 and 1 can be linked to form a buffered output compare channel whose output appears on the PTE4/TCH0B pin. The TIMB channel registers of the linked pair alternately control the output.

Setting the MS0B bit in TIMB channel 0 status and control register (TBSC0) links channel 0 and channel 1. The output compare value in the TIMB channel 0 registers initially controls the output on the PTE4/TCH0B pin. Writing to the TIMB channel 1 registers enables the TIMB channel 1 registers to synchronously control the output after the TIMB overflows. At each subsequent overflow, the TIMB channel registers (0 or 1) that control the output are the ones written to last. TBSC0 controls and monitors the buffered output compare function, and TIMB channel 1 status and control register (TBSC1) is unused. While the MS0B bit is set, the channel 1 pin, PTE5/TCH1B, is available as a general-purpose I/O pin.

Channels 2 and 3 can be linked to form a buffered output compare channel whose output appears on the PTE6/TCH2B pin. The TIMB channel registers of the linked pair alternately control the output.

Setting the MS2B bit in TIMB channel 2 status and control register (TBSC2) links channel 2 and channel 3. The output compare value in the TIMB channel 2 registers initially controls the output on the PTE6/TCH2B pin. Writing to the TIMB channel 3 registers enables the TIMB channel 3 registers to synchronously control the output after the TIMB overflows. At each subsequent overflow, the TIMB channel registers (2 or 3) that control the output are the ones written to last. TBSC2 controls and monitors the buffered output compare function, and TIMB channel 3 status and control register (TBSC3) is unused. While the MS2B bit is set, the channel 3 pin, PTE7/TCH3B, is available as a general-purpose I/O pin.

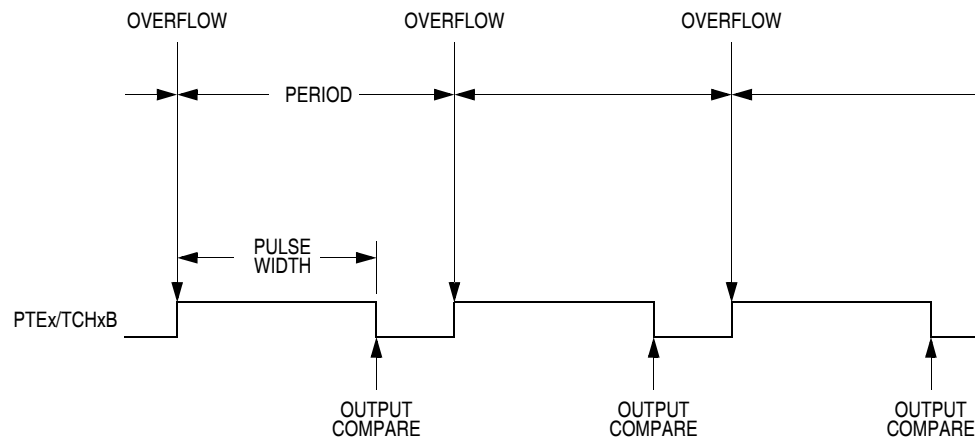
**NOTE:** *In buffered output compare operation, do not write new output compare values to the currently active channel registers. Writing to the active channel registers is the same as generating unbuffered output compares.*

### 12.4.4 Pulse Width Modulation (PWM)

By using the toggle-on-overflow feature with an output compare channel, the TIMB can generate a PWM signal. The value in the TIMB counter modulo registers determines the period of the PWM signal. The channel pin toggles when the counter reaches the value in the TIMB counter modulo registers. The time between overflows is the period of the PWM signal.

As [Figure 12-3](#) shows, the output compare value in the TIMB channel registers determines the pulse width of the PWM signal. The time between overflow and output compare is the pulse width. Program the TIMB to clear the channel pin on output compare if the state of the PWM pulse is logic 1. Program the TIMB to set the pin if the state of the PWM pulse is logic 0.





**Figure 12-3. PWM Period and Pulse Width**

The value in the TIMB counter modulo registers and the selected prescaler output determines the frequency of the PWM output. The frequency of an 8-bit PWM signal is variable in 256 increments. Writing \$00FF (255) to the TIMB counter modulo registers produces a PWM period of 256 times the internal bus clock period if the prescaler select value is \$000 (see [12.9.1 TIMB Status and Control Register](#)).

The value in the TIMB channel registers determines the pulse width of the PWM output. The pulse width of an 8-bit PWM signal is variable in 256 increments. Writing \$0080 (128) to the TIMB channel registers produces a duty cycle of 128/256 or 50%.

#### 12.4.4.1 Unbuffered PWM Signal Generation

Any output compare channel can generate unbuffered PWM pulses as described in [12.4.4 Pulse Width Modulation \(PWM\)](#). The pulses are unbuffered because changing the pulse width requires writing the new pulse width value over the old value currently in the TIMB channel registers.

An unsynchronized write to the TIMB channel registers to change a pulse width value could cause incorrect operation for up to two PWM periods. For example, writing a new value before the counter reaches the old value but after the counter reaches the new value prevents any compare during that PWM period. Also, using a TIMB overflow interrupt

routine to write a new, smaller pulse width value can cause the compare to be missed. The TIMB may pass the new value before it is written.

Use the following methods to synchronize unbuffered changes in the PWM pulse width on channel x:

- When changing to a shorter pulse width, enable channel x output compare interrupts and write the new value in the output compare interrupt routine. The output compare interrupt occurs at the end of the current pulse. The interrupt routine has until the end of the PWM period to write the new value.
- When changing to a longer pulse width, enable channel x TIMB overflow interrupts and write the new value in the TIMB overflow interrupt routine. The TIMB overflow interrupt occurs at the end of the current PWM period. Writing a larger value in an output compare interrupt routine (at the end of the current pulse) could cause two output compares to occur in the same PWM period.

**NOTE:** *In PWM signal generation, do not program the PWM channel to toggle on output compare. Toggling on output compare prevents reliable 0% duty cycle generation and removes the ability of the channel to self-correct in the event of software error or noise. Toggling on output compare also can cause incorrect PWM signal generation when changing the PWM pulse width to a new, much larger value.*

### 12.4.4.2 Buffered PWM Signal Generation

Channels 0 and 1 can be linked to form a buffered PWM channel whose output appears on the PTE4/TCH0B pin. The TIMB channel registers of the linked pair alternately control the pulse width of the output.

Setting the MS0B bit in TIMB channel 0 status and control register (TBSC0) links channel 0 and channel 1. The TIMB channel 0 registers initially control the pulse width on the PTE4/TCH0B pin. Writing to the TIMB channel 1 registers enables the TIMB channel 1 registers to synchronously control the pulse width at the beginning of the next PWM period. At each subsequent overflow, the TIMB channel registers (0 or 1) that control the pulse width are the ones written to last. TBSC0 controls and monitors the buffered PWM function, and TIMB channel 1

status and control register (TBSC1) is unused. While the MS0B bit is set, the channel 1 pin, PTE5/TCH1B, is available as a general-purpose I/O pin.

Channels 2 and 3 can be linked to form a buffered PWM channel whose output appears on the PTE6/TCH2B pin. The TIMB channel registers of the linked pair alternately control the pulse width of the output.

Setting the MS2B bit in TIMB channel 2 status and control register (TBSC2) links channel 2 and channel 3. The TIMB channel 2 registers initially control the pulse width on the PTE6/TCH2B pin. Writing to the TIMB channel 3 registers enables the TIMB channel 3 registers to synchronously control the pulse width at the beginning of the next PWM period. At each subsequent overflow, the TIMB channel registers (2 or 3) that control the pulse width are the ones written to last. TBSC2 controls and monitors the buffered PWM function, and TIMB channel 3 status and control register (TBSC3) is unused. While the MS2B bit is set, the channel 3 pin, PTE7/TCH3B, is available as a general-purpose I/O pin.

**NOTE:** *In buffered PWM signal generation, do not write new pulse width values to the currently active channel registers. Writing to the active channel registers is the same as generating unbuffered PWM signals.*

#### 12.4.4.3 PWM Initialization

To ensure correct operation when generating unbuffered or buffered PWM signals, use the following initialization procedure:

1. In the TIMB status and control register (TBSC):
  - a. Stop the TIMB counter by setting the TIMB stop bit, TSTOP.
  - b. Reset the TIMB counter by setting the TIMB reset bit, TRST.
2. In the TIMB counter modulo registers (TBMODH:TBMODL), write the value for the required PWM period.
3. In the TIMB channel x registers (TBCHxH:TBCHxL), write the value for the required pulse width.

4. In TIMB channel x status and control register (TBSCx):
  - a. Write 0:1 (for unbuffered output compare or PWM signals) or 1:0 (for buffered output compare or PWM signals) to the mode select bits, MSxB:MSxA. (See [Table 12-2](#).)
  - b. Write 1 to the toggle-on-overflow bit, TOVx.
  - c. Write 1:0 (to clear output on compare) or 1:1 (to set output on compare) to the edge/level select bits, ELSxB:ELSxA. The output action on compare must force the output to the complement of the pulse width level. (See [Table 12-2](#).)

**NOTE:** *In PWM signal generation, do not program the PWM channel to toggle on output compare. Toggling on output compare prevents reliable 0% duty cycle generation and removes the ability of the channel to self-correct in the event of software error or noise. Toggling on output compare can also cause incorrect PWM signal generation when changing the PWM pulse width to a new, much larger value.*

5. In the TIMB status control register (TBSC), clear the TIMB stop bit, TSTOP.

Setting MS0B links channels 0 and 1 and configures them for buffered PWM operation. The TIMB channel 0 registers (TBCH0H:TBCH0L) initially control the buffered PWM output. TIMB status control register 0 (TBSCR0) controls and monitors the PWM signal from the linked channels. MS0B takes priority over MS0A.

Setting MS2B links channels 2 and 3 and configures them for buffered PWM operation. The TIMB channel 2 registers (TBCH2H:TBCH2L) initially control the PWM output. TIMB status control register 2 (TBSCR2) controls and monitors the PWM signal from the linked channels. MS2B takes priority over MS2A.

Clearing the toggle-on-overflow bit, TOVx, inhibits output toggles on TIMB overflows. Subsequent output compares try to force the output to a state it is already in and have no effect. The result is a 0% duty cycle output.

Setting the channel x maximum duty cycle bit (CHxMAX) and clearing the TOVx bit generates a 100% duty cycle output. (See [12.9.4 TIMB Channel Status and Control Registers](#).)

## 12.5 Interrupts

The following TIMB sources can generate interrupt requests:

- TIMB overflow flag (TOF) — The TOF bit is set when the TIMB counter value rolls over to \$0000 after matching the value in the TIMB counter modulo registers. The TIMB overflow interrupt enable bit, TOIE, enables TIMB overflow CPU interrupt requests. TOF and TOIE are in the TIMB status and control register.
- TIMB channel flags (CH3F–CH0F) — The CHxF bit is set when an input capture or output compare occurs on channel x. Channel x TIM CPU interrupt requests are controlled by the channel x interrupt enable bit, CHxIE. Channel x TIM CPU interrupt requests are enabled when CHxIE = 1.
- CHxF and CHxIE are in the TIMB channel x status and control register.

## 12.6 Wait Mode

The WAIT instruction puts the MCU in low-power-consumption standby mode.

The TIMB remains active after the execution of a WAIT instruction. In wait mode the TIMB registers are not accessible by the CPU. Any enabled CPU interrupt request from the TIMB can bring the MCU out of wait mode.

If TIMB functions are not required during wait mode, reduce power consumption by stopping the TIMB before executing the WAIT instruction.

### 12.7 TIMB During Break Interrupts

A break interrupt stops the TIMB counter.

The system integration module (SIM) controls whether status bits in other modules can be cleared during the break state. The BCFE bit in the SIM break flag control register (SBFCR) enables software to clear status bits during the break state. (See [7.7.4 SIM Break Flag Control Register](#).)

To allow software to clear status bits during a break interrupt, write a logic 1 to the BCFE bit. If a status bit is cleared during the break state, it remains cleared when the MCU exits the break state.

To protect status bits during the break state, write a logic 0 to the BCFE bit. With BCFE at logic 0 (its default state), software can read and write I/O registers during the break state without affecting status bits. Some status bits have a two-step read/write clearing procedure. If software does the first step on such a bit before the break, the bit cannot change during the break state as long as BCFE is at logic 0. After the break, doing the second step clears the status bit.

### 12.8 I/O Signals

Port E shares five of its pins with the TIM. PTE3/TCLKB is an external clock input to the TIMB prescaler. The four TIMB channel I/O pins are PTE4/TCH0B, PTE5/TCH1B, PTE6/TCH2B, and PTE7/TCH3B.

#### 12.8.1 TIMB Clock Pin (PTE3/TCLKB)

PTE3/TCLKB is an external clock input that can be the clock source for the TIMB counter instead of the prescaled internal bus clock. Select the PTE3/TCLKB input by writing logic 1s to the three prescaler select bits, PS[2:0]. (See [12.9.1 TIMB Status and Control Register](#).)

The minimum TCLK pulse width,  $TCLK_{LMIN}$  or  $TCLK_{HMIN}$ , is:

$$\frac{1}{\text{bus frequency}} + t_{SU}$$

The maximum TCLK frequency is:

$$\text{bus frequency} \div 2$$

PTE3/TCLKB is available as a general-purpose I/O pin when not used as the TIMB clock input. When the PTE3/TCLKB pin is the TIMB clock input, it is an input regardless of the state of the DDRE3 bit in data direction register E.

### 12.8.2 TIMB Channel I/O Pins (PTE4/TCH0B:PTE7/TCH3B)

Each channel I/O pin is programmable independently as an input capture pin or an output compare pin. PTE4/TCH0B and PTE6/TCH2B can be configured as buffered output compare or buffered PWM pins.

## 12.9 I/O Registers

The following I/O registers control and monitor operation of the TIMB:

- TIMB status and control register (TBSC)
- TIMB control registers (TBCNTH:TBCNTL)
- TIMB counter modulo registers (TBMODH:TBMODL)
- TIMB channel status and control registers (TBSC0, TBSC1, TBSC2, and TBSC3)
- TIMB channel registers (TBCH0H:TBCH0L, TBCH1H:TBCH1L, TBCH2H:TBCH2L, and TBCH3H:TBCH3L)


## 12.9.1 TIMB Status and Control Register

The TIMB status and control register does the following:

- Enables TIMB overflow interrupts
- Flags TIMB overflows
- Stops the TIMB counter
- Resets the TIMB counter
- Prescales the TIMB counter clock

Address: \$003F

	Bit 7	6	5	4	3	2	1	Bit 0
Read:	TOF	TOIE	TSTOP	0	0	PS2	PS1	PS0
Write:	0			TRST				
Reset:	0	0	1	0	0	0	0	0

 = Unimplemented

**Figure 12-4. TIMB Status and Control Register (TBSC)**

### TOF — TIMB Overflow Flag Bit

This read/write flag is set when the TIMB counter resets to \$0000 after reaching the modulo value programmed in the TIMB counter modulo registers. Clear TOF by reading the TIMB status and control register when TOF is set and then writing a logic 0 to TOF. If another TIMB overflow occurs before the clearing sequence is complete, then writing logic 0 to TOF has no effect. Therefore, a TOF interrupt request cannot be lost due to inadvertent clearing of TOF. Reset clears the TOF bit. Writing a logic 1 to TOF has no effect.

- 1 = TIMB counter has reached modulo value
- 0 = TIMB counter has not reached modulo value

### TOIE — TIMB Overflow Interrupt Enable Bit

This read/write bit enables TIMB overflow interrupts when the TOF bit becomes set. Reset clears the TOIE bit.

- 1 = TIMB overflow interrupts enabled
- 0 = TIMB overflow interrupts disabled



**TSTOP — TIMB Stop Bit**

This read/write bit stops the TIMB counter. Counting resumes when TSTOP is cleared. Reset sets the TSTOP bit, stopping the TIMB counter until software clears the TSTOP bit.

1 = TIMB counter stopped

0 = TIMB counter active

**NOTE:** *Do not set the TSTOP bit before entering wait mode if the TIMB is required to exit wait mode.*

**TRST — TIMB Reset Bit**

Setting this write-only bit resets the TIMB counter and the TIMB prescaler. Setting TRST has no effect on any other registers.

Counting resumes from \$0000. TRST is cleared automatically after the TIMB counter is reset and always reads as logic 0. Reset clears the TRST bit.

1 = Prescaler and TIMB counter cleared

0 = No effect

**NOTE:** *Setting the TSTOP and TRST bits simultaneously stops the TIMB counter at a value of \$0000.*

**PS[2:0] — Prescaler Select Bits**

These read/write bits select either the PTE3/TCLKB pin or one of the seven prescaler outputs as the input to the TIMB counter as [Table 12-1](#) shows. Reset clears the PS[2:0] bits.

**Table 12-1. Prescaler Selection**


PS[2:0]	TIMB Clock Source
000	Internal Bus Clock ÷ 1
001	Internal Bus Clock ÷ 2
010	Internal Bus Clock ÷ 4
011	Internal Bus Clock ÷ 8
100	Internal Bus Clock ÷ 16
101	Internal Bus Clock ÷ 32
110	Internal Bus Clock ÷ 64
111	PTE3/TCLKB

## 12.9.2 TIMB Counter Registers

The two read-only TIMB counter registers contain the high and low bytes of the value in the TIMB counter. Reading the high byte (TBCNTH) latches the contents of the low byte (TBCNTL) into a buffer. Subsequent reads of TBCNTH do not affect the latched TBCNTL value until TBCNTL is read. Reset clears the TIMB counter registers. Setting the TIMB reset bit (TRST) also clears the TIMB counter registers.

**NOTE:** *If you read TBCNTH during a break interrupt, be sure to unlatch TBCNTL by reading TBCNTL before exiting the break interrupt. Otherwise, TBCNTL retains the value latched during the break.*

TBCNTH								
\$0040	Bit 7	6	5	4	3	2	1	Bit 0
Read:	Bit 15	14	13	12	11	10	9	Bit 8
Write:								
Reset:	0	0	0	0	0	0	0	0
TBCNTL								
\$0041	Bit 7	6	5	4	3	2	1	Bit 0
Read:	Bit 7	6	5	4	3	2	1	Bit 0
Write:								
Reset:	0	0	0	0	0	0	0	0

 = Unimplemented

**Figure 12-5. TIMB Counter Registers (TBCNTH:TBCNTL)**

### 12.9.3 TIMB Counter Modulo Registers

The read/write TIMB modulo registers contain the modulo value for the TIMB counter. When the TIMB counter reaches the modulo value, the overflow flag (TOF) becomes set, and the TIMB counter resumes counting from \$0000 at the next clock. Writing to the high byte (TBMODH) inhibits the TOF bit and overflow interrupts until the low byte (TBMODL) is written. Reset sets the TIMB counter modulo registers.

TBMODH								
\$0042	Bit 7	6	5	4	3	2	1	Bit 0
Read:	Bit 15	14	13	12	11	10	9	Bit 8
Write:								
Reset:	1	1	1	1	1	1	1	1
TBMODL								
\$0043	Bit 7	6	5	4	3	2	1	Bit 0
Read:	Bit 7	6	5	4	3	2	1	Bit 0
Write:								
Reset:	1	1	1	1	1	1	1	1

**Figure 12-6. TIMB Counter Modulo Registers (TBMODH:TBMODL)**

**NOTE:** *Reset the TIMB counter before writing to the TIMB counter modulo registers.*

## 12.9.4 TIMB Channel Status and Control Registers

Each of the TIMB channel status and control registers does the following:

- Flags input captures and output compares
- Enables input capture and output compare interrupts
- Selects input capture, output compare, or PWM operation
- Selects high, low, or toggling output on output compare
- Selects rising edge, falling edge, or any edge as the active input capture trigger
- Selects output toggling on TIMB overflow
- Selects 100% PWM duty cycle
- Selects buffered or unbuffered output compare/PWM operation

TBSC0		Bit 7	6	5	4	3	2	1	Bit 0
Read:	CH0F	CH0IE	MS0B	MS0A	ELS0B	ELS0A	TOV0	CH0MAX	
Write:	0								
Reset:	0	0	0	0	0	0	0	0	0
TBSC1									
\$0047		Bit 7	6	5	4	3	2	1	Bit 0
Read:	CH1F	CH1IE	0	MS1A	ELS1B	ELS1A	TOV1	CH1MAX	
Write:	0								
Reset:	0	0	0	0	0	0	0	0	0
TBSC2									
\$004A		Bit 7	6	5	4	3	2	1	Bit 0
Read:	CH2F	CH2IE	MS2B	MS2A	ELS2B	ELS2A	TOV2	CH2MAX	
Write:	0								
Reset:	0	0	0	0	0	0	0	0	0
TBSC3									
\$004D		Bit 7	6	5	4	3	2	1	Bit 0
Read:	CH3F	CH3IE	0	MS3A	ELS3B	ELS3A	TOV3	CH3MAX	
Write:	0								
Reset:	0	0	0	0	0	0	0	0	0

= Unimplemented

**Figure 12-7. TIMB Channel Status and Control Registers (TBSC0:TBSC3)**

**CHxF — Channel x Flag Bit**

When channel x is an input capture channel, this read/write bit is set when an active edge occurs on the channel x pin. When channel x is an output compare channel, CHxF is set when the value in the TIMB counter registers matches the value in the TIMB channel x registers.

When TIM CPU interrupt requests are enabled (CHxIE = 1), clear CHxF by reading TIMB channel x status and control register with CHxF set and then writing a logic 0 to CHxF. If another interrupt request occurs before the clearing sequence is complete, then writing logic 0 to CHxF has no effect. Therefore, an interrupt request cannot be lost due to inadvertent clearing of CHxF.

Reset clears the CHxF bit. Writing a logic 1 to CHxF has no effect.

1 = Input capture or output compare on channel x

0 = No input capture or output compare on channel x

**CHxIE — Channel x Interrupt Enable Bit**

This read/write bit enables TIMB CPU interrupts on channel x.

Reset clears the CHxIE bit.

1 = Channel x CPU interrupt requests enabled

0 = Channel x CPU interrupt requests disabled

**MSxB — Mode Select Bit B**

This read/write bit selects buffered output compare/PWM operation. MSxB exists only in the TIMB channel 0 and TIMB channel 2 status and control registers.

Setting MS0B disables the channel 1 status and control register and reverts TCH1B to general-purpose I/O.

Setting MS2B disables the channel 3 status and control register and reverts TCH3B to general-purpose I/O.

Reset clears the MSxB bit.

1 = Buffered output compare/PWM operation enabled

0 = Buffered output compare/PWM operation disabled

### MSxA — Mode Select Bit A

When ELSxB:A  $\neq$  00, this read/write bit selects either input capture operation or unbuffered output compare/PWM operation. (See [Table 12-2](#).)

1 = Unbuffered output compare/PWM operation

0 = Input capture operation

When ELSxB:A = 00, this read/write bit selects the initial output level of the TCHxB pin. (See [Table 12-2](#).) Reset clears the MSxA bit.

1 = Initial output level low

0 = Initial output level high

**NOTE:** *Before changing a channel function by writing to the MSxB or MSxA bit, set the TSTOP and TRST bits in the TIMB status and control register (TBSC).*

### ELSxB and ELSxA — Edge/Level Select Bits

When channel x is an input capture channel, these read/write bits control the active edge-sensing logic on channel x.

When channel x is an output compare channel, ELSxB and ELSxA control the channel x output behavior when an output compare occurs.

When ELSxB and ELSxA are both clear, channel x is not connected to port E, and pin PTE/TCHxB is available as a general-purpose I/O pin. [Table 12-2](#) shows how ELSxB and ELSxA work. Reset clears the ELSxB and ELSxA bits.

**NOTE:** *Before enabling a TIMB channel register for input capture operation, make sure that the PTE/TCHxB pin is stable for at least two bus clocks.*

**Table 12-2. Mode, Edge, and Level Selection**

MSxB:MSxA	ELSxB:ELSxA	Mode	Configuration
X0	00	Output Preset	Pin under Port Control; Initial Output Level High
X1	00		Pin under Port Control; Initial Output Level Low
00	01	Input Capture	Capture on Rising Edge Only
00	10		Capture on Falling Edge Only
00	11		Capture on Rising or Falling Edge
01	01	Output Compare or PWM	Toggle Output on Compare
01	10		Clear Output on Compare
01	11		Set Output on Compare
1X	01	Buffered Output Compare or Buffered PWM	Toggle Output on Compare
1X	10		Clear Output on Compare
1X	11		Set Output on Compare

**TOVx — Toggle-On-Overflow Bit**

When channel x is an output compare channel, this read/write bit controls the behavior of the channel x output when the TIMB counter overflows. When channel x is an input capture channel, TOVx has no effect. Reset clears the TOVx bit.

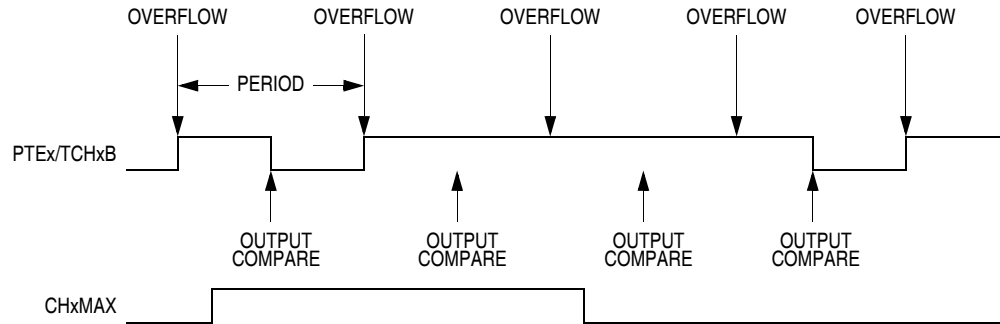
1 = Channel x pin toggles on TIMB counter overflow.

0 = Channel x pin does not toggle on TIMB counter overflow.

**NOTE:** When TOVx is set, a TIMB counter overflow takes precedence over a channel x output compare if both occur at the same time.

**CHxMAX — Channel x Maximum Duty Cycle Bit**

When the TOVx bit is at logic 0, setting the CHxMAX bit forces the duty cycle of buffered and unbuffered PWM signals to 100%. As [Figure 12-8](#) shows, the CHxMAX bit takes effect in the cycle after it is set or cleared. The output stays at the 100% duty cycle level until the cycle after CHxMAX is cleared.



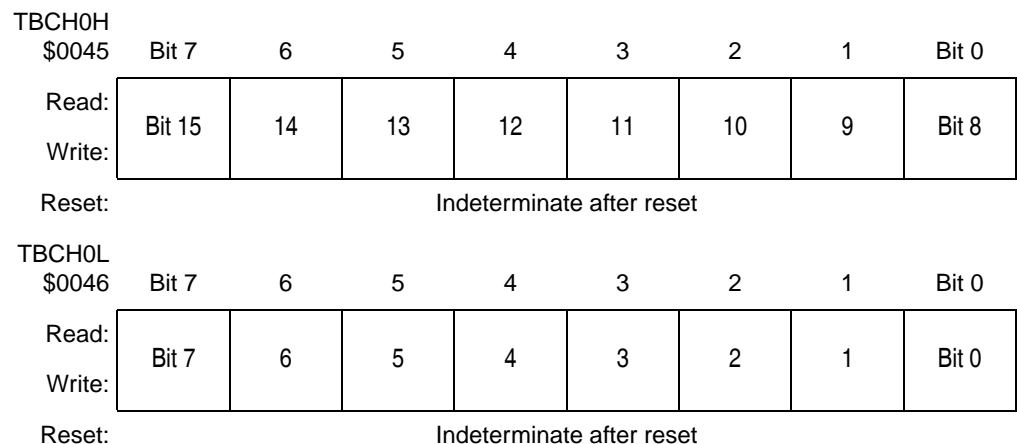
**Figure 12-8. CHxMAX Latency**

## 12.9.5 TIMB Channel Registers

These read/write registers contain the captured TIMB counter value of the input capture function or the output compare value of the output compare function. The state of the TIMB channel registers after reset is unknown.

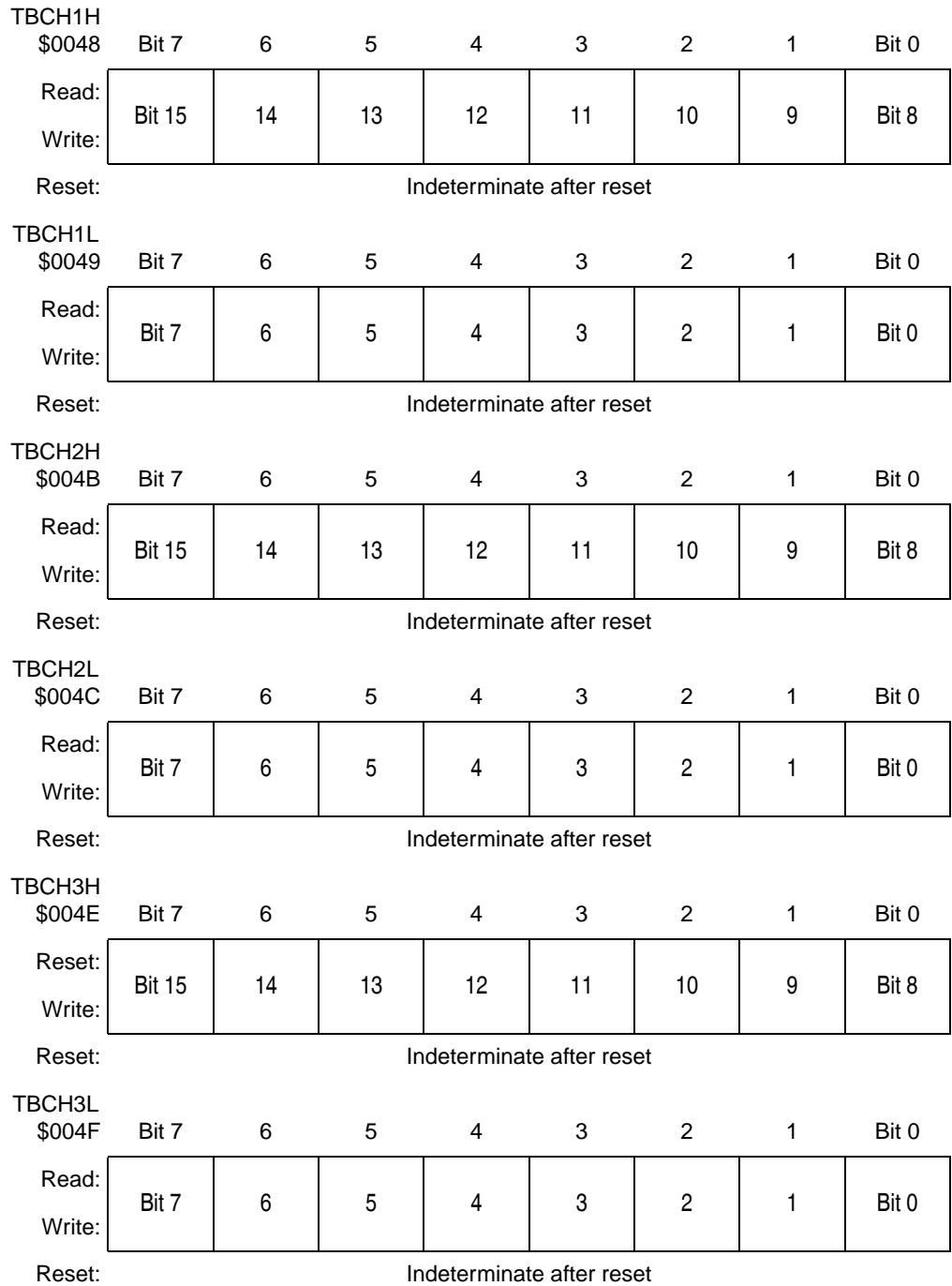
In input capture mode ( $MSxB:MSxA = 0:0$ ), reading the high byte of the TIMB channel x registers (TBCHxH) inhibits input captures until the low byte (TBCHxL) is read.

In output compare mode ( $MSxB:MSxA \neq 0:0$ ), writing to the high byte of the TIMB channel x registers (TBCHxH) inhibits output compares until the low byte (TBCHxL) is written.



**Figure 12-9. TIMB Channel Registers (TBCH0H/L:TBCH3H/L)**





**Figure 12-9. TIMB Channel Registers (TBCH0H/L:TBCH3H/L) (Continued)**



## Section 13. Serial Peripheral Interface Module (SPI)

### 13.1 Contents

13.2	Introduction	252
13.3	Features	252
13.4	Pin Name Conventions	253
13.5	Functional Description	254
13.5.1	Master Mode	255
13.5.2	Slave Mode	257
13.6	Transmission Formats	258
13.6.1	Clock Phase and Polarity Controls	258
13.6.2	Transmission Format When CPHA = 0	258
13.6.3	Transmission Format When CPHA = 1	260
13.6.4	Transmission Initiation Latency	261
13.7	Queuing Transmission Data	263
13.8	Error Conditions	264
13.8.1	Overflow Error	264
13.8.2	Mode Fault Error	267
13.9	Interrupts	269
13.10	Resetting the SPI	271
13.11	Low-Power Mode	272
13.12	SPI During Break Interrupts	272
13.13	I/O Signals	273
13.13.1	MISO (Master In/Slave Out)	273
13.13.2	MOSI (Master Out/Slave In)	274
13.13.3	SPSCK (Serial Clock)	274
13.13.4	$\overline{SS}$ (Slave Select)	274
13.13.5	CGND (Clock Ground)	276

13.14 I/O Registers . . . . .	276
13.14.1 SPI Control Register . . . . .	277
13.14.2 SPI Status and Control Register . . . . .	279
13.14.3 SPI Data Register . . . . .	282

## 13.2 Introduction

The SPI allows full-duplex, synchronous, serial communications with peripheral devices.

## 13.3 Features

Features of the SPI module include the following:

- Full-duplex operation
- Master and slave modes
- Double-buffered operation with separate transmit and receive registers
- Four master mode frequencies (maximum = bus frequency  $\div$  2)
- Maximum slave mode frequency = bus frequency
- Clock ground for reduced radio frequency (RF) interference
- Serial clock with programmable polarity and phase
- Two separately enabled interrupts with CPU service:
  - SPRF (SPI receiver full)
  - SPTE (SPI transmitter empty)
- Mode fault error flag with cpu interrupt capability
- Overflow error flag with CPU interrupt capability
- Programmable wired-OR mode
- I<sup>2</sup>C (inter-integrated circuit) compatibility

## 13.4 Pin Name Conventions

The generic names of the SPI I/O pins are:

- $\overline{SS}$  (slave select)
- SPSCCK (SPI serial clock)
- CGND (clock ground)
- MOSI (master out slave in)
- MISO (master in slave out)

SPI pins are shared by parallel I/O ports or have alternate functions. The full name of an SPI pin reflects the name of the shared port pin or the name of an alternate pin function. The generic pin names appear in the text that follows. [Table 13-1](#) shows the full names of the SPI I/O pins.

**Table 13-1. Pin Name Conventions**

Generic Pin Names:	MISO	MOSI	SPSCCK	$\overline{SS}$	CGND
Full Pin Names:	PF3/MISO	PF2/MOSI	PF0/SPSCCK	PF1/ $\overline{SS}$	CGND/ $EV_{SS}$

# Serial Peripheral Interface Module (SPI)

## 13.5 Functional Description

Figure 13-1 shows the structure of the SPI module and Figure 13-2 shows the locations and contents of the SPI I/O registers.

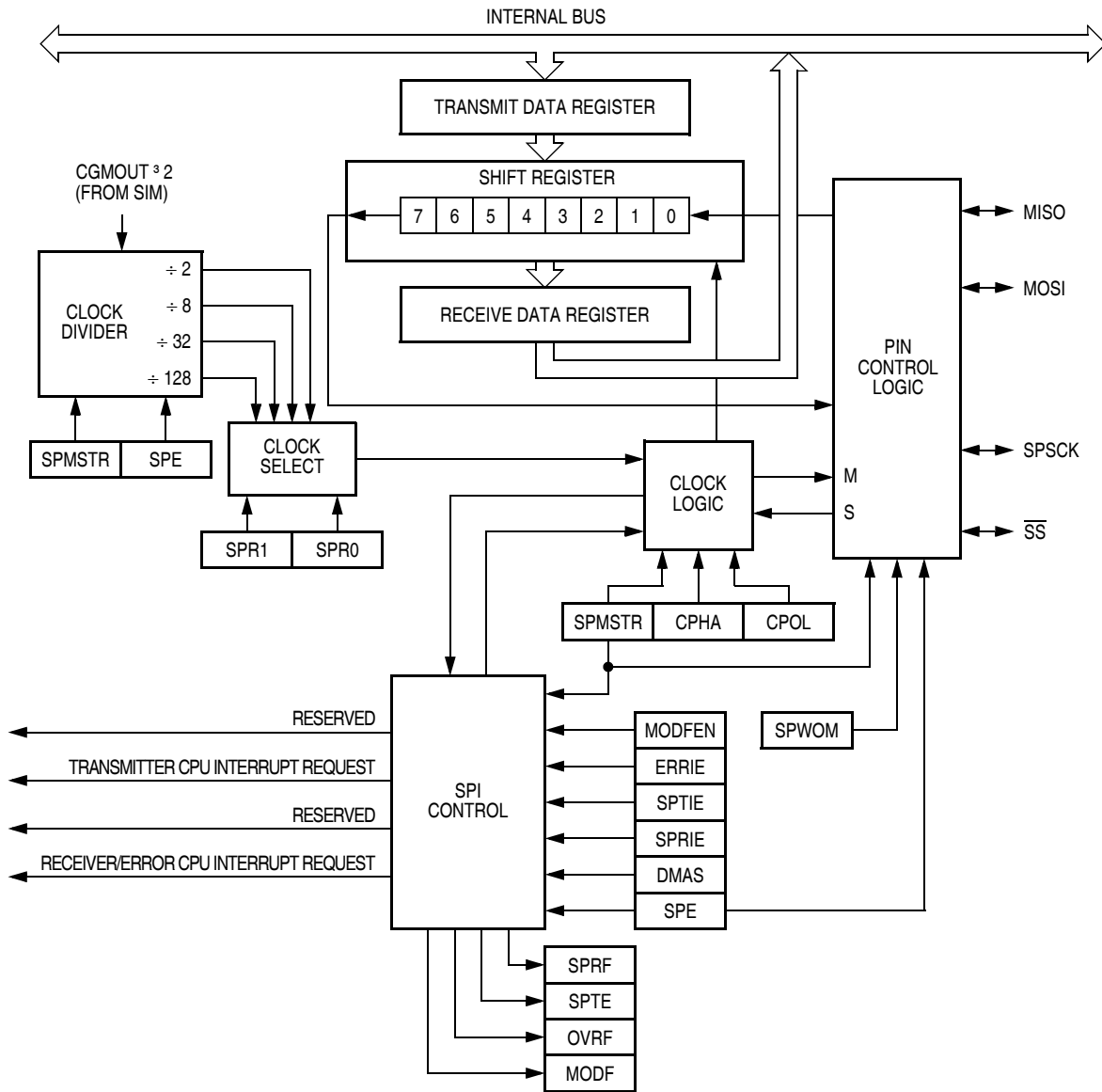



Figure 13-1. SPI Module Block Diagram

Addr.	Name	Bit 7	6	5	4	3	2	1	Bit 0	
\$001B	SPI Control Register (SPCR)	Read:	SPRIE	DMAS	SPMSTR	CPOL	CPHA	SPWOM	SPE	SPTIE
		Write:								
		Reset:	0	0	1	0	1	0	0	0
\$001C	SPI Status and Control Register (SPSCR)	Read:	SPRF	ERRIE	OVRF	MODF	SPTIE	MODFEN	SPR1	SPR0
		Write:								
		Reset:	0	0	0	0	1	0	0	0
\$001D	SPI Data Register (SPDR)	Read:	R7	R6	R5	R4	R3	R2	R1	R0
		Write:	T7	T6	T5	T4	T3	T2	T1	T0
		Reset:	Indeterminate after reset							

 = Unimplemented

**Figure 13-2. SPI I/O Register Summary**

The SPI module allows full-duplex, synchronous, serial communication between the MCU and peripheral devices, including other MCUs. Software can poll the SPI status flags or SPI operation can be interrupt-driven. All SPI interrupts can be serviced by the CPU.

The following paragraphs describe the operation of the SPI module.

### 13.5.1 Master Mode

The SPI operates in master mode when the SPI master bit, SPMSTR, is set.

**NOTE:** *Configure the SPI modules as master or slave before enabling them. Enable the master SPI before enabling the slave SPI. Disable the slave SPI before disabling the master SPI. (See [13.14.1 SPI Control Register](#).)*

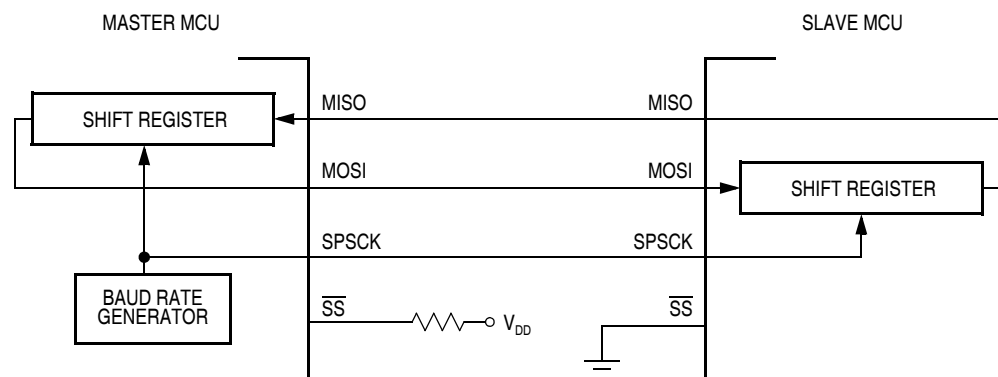
## Serial Peripheral Interface Module (SPI)

Only a master SPI module can initiate transmissions. Software begins the transmission from a master SPI module by writing to the transmit data register. If the shift register is empty, the byte immediately transfers to the shift register, setting the SPI transmitter empty bit, SPTE. The byte begins shifting out on the MOSI pin under the control of the serial clock. See [Figure 13-3](#).

The SPR1 and SPR0 bits control the baud rate generator and determine the speed of the shift register. (See [13.14.2 SPI Status and Control Register](#).) Through the SPSCCK pin, the baud rate generator of the master also controls the shift register of the slave peripheral.

As the byte shifts out on the MOSI pin of the master, another byte shifts in from the slave on the master's MISO pin. The transmission ends when the receiver full bit, SPRF, becomes set. At the same time that SPRF becomes set, the byte from the slave transfers to the receive data register. In normal operation, SPRF signals the end of a transmission. Software clears SPRF by reading the SPI status and control register with SPRF set and then reading the SPI data register. Writing to the SPI data register clears the SPTE bit.

When the DMAS bit is set, the SPI status and control register does not have to be read to clear the SPRF bit. A read of the SPI data register by the CPU clears the SPRF bit. A write to the SPI data register by the CPU clears the SPTE bit.



**Figure 13-3. Full-Duplex Master-Slave Connections**



### 13.5.2 Slave Mode

The SPI operates in slave mode when the SPMSTR bit is clear. In slave mode the SPSCCK pin is the input for the serial clock from the master MCU. Before a data transmission occurs, the  $\overline{SS}$  pin of the slave SPI must be at logic 0.  $\overline{SS}$  must remain low until the transmission is complete. (See [13.8.2 Mode Fault Error](#).)

In a slave SPI module, data enters the shift register under the control of the serial clock from the master SPI module. After a byte enters the shift register of a slave SPI, it transfers to the receive data register, and the SPRF bit is set. To prevent an overflow condition, slave software then must read the receive data register before another full byte enters the shift register.

The maximum frequency of the SPSCCK for an SPI configured as a slave is the bus clock speed (which is twice as fast as the fastest master SPSCCK clock that can be generated). The frequency of the SPSCCK for an SPI configured as a slave does not have to correspond to any SPI baud rate. The baud rate only controls the speed of the SPSCCK generated by an SPI configured as a master. Therefore, the frequency of the SPSCCK for an SPI configured as a slave can be any frequency less than or equal to the bus speed.

When the master SPI starts a transmission, the data in the slave shift register begins shifting out on the MISO pin. The slave can load its shift register with a new byte for the next transmission by writing to its transmit data register. The slave must write to its transmit data register at least one bus cycle before the master starts the next transmission. Otherwise the byte already in the slave shift register shifts out on the MISO pin. Data written to the slave shift register during a transmission remains in a buffer until the end of the transmission.

When the clock phase bit (CPHA) is set, the first edge of SPSCCK starts a transmission. When CPHA is clear, the falling edge of  $\overline{SS}$  starts a transmission. (See [13.6 Transmission Formats](#).)

**NOTE:** *SPSCCK must be in the proper idle state before the slave is enabled to prevent SPSCCK from appearing as a clock edge.*

## 13.6 Transmission Formats

During an SPI transmission, data is simultaneously transmitted (shifted out serially) and received (shifted in serially). A serial clock synchronizes shifting and sampling on the two serial data lines. A slave select line allows selection of an individual slave SPI device; slave devices that are not selected do not interfere with SPI bus activities. On a master SPI device, the slave select line can optionally be used to indicate multiple-master bus contention.

### 13.6.1 Clock Phase and Polarity Controls

Software can select any of four combinations of serial clock (SPSCK) phase and polarity using two bits in the SPI control register (SPCR). The clock polarity is specified by the CPOL control bit, which selects an active high or low clock and has no significant effect on the transmission format.

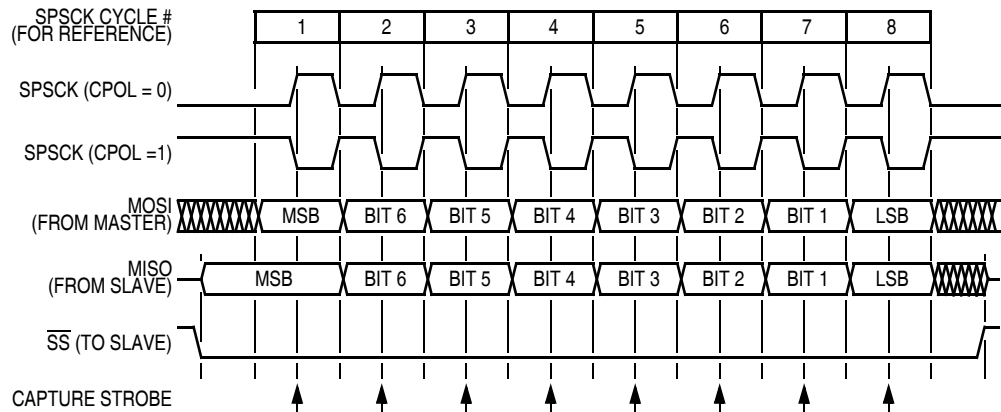
The clock phase (CPHA) control bit selects one of two fundamentally different transmission formats. The clock phase and polarity should be identical for the master SPI device and the communicating slave device. In some cases, the phase and polarity are changed between transmissions to allow a master device to communicate with peripheral slaves having different requirements.

**NOTE:** *Before writing to the CPOL bit or the CPHA bit, disable the SPI by clearing the SPI enable bit (SPE) .*

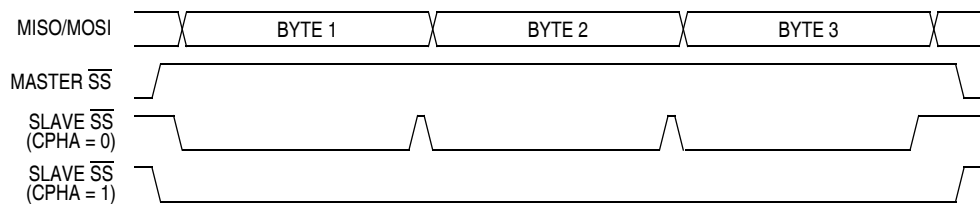
### 13.6.2 Transmission Format When CPHA = 0

**Figure 13-4** shows an SPI transmission in which CPHA is logic 0. The figure should not be used as a replacement for data sheet parametric information. Two waveforms are shown for SPSCK: one for CPOL = 0 and another for CPOL = 1. The diagram may be interpreted as a master or slave timing diagram since the serial clock (SPSCK), master in/slave out (MISO), and master out/slave in (MOSI) pins are directly connected between the master and the slave. The MISO signal is the output from the slave, and the MOSI signal is the output from the master. The  $\overline{SS}$  line

is the slave select input to the slave. The slave SPI drives its MISO output only when its slave select input ( $\overline{SS}$ ) is at logic 0, so that only the selected slave drives to the master. The  $\overline{SS}$  pin of the master is not shown but is assumed to be inactive. The  $\overline{SS}$  pin of the master must be high or must be reconfigured as general-purpose I/O not affecting the SPI. (See **13.8.2 Mode Fault Error**.) When  $CPHA = 0$ , the first SPSCCK edge is the MSB capture strobe. Therefore the slave must begin driving its data before the first SPSCCK edge, and a falling edge on the  $\overline{SS}$  pin is used to start the slave data transmission. The slave's  $\overline{SS}$  pin must be toggled back to high and then low again between each byte transmitted as shown in **Figure 13-5**.



**Figure 13-4. Transmission Format (CPHA = 0)**



**Figure 13-5. CPHA/ $\overline{SS}$  Timing**

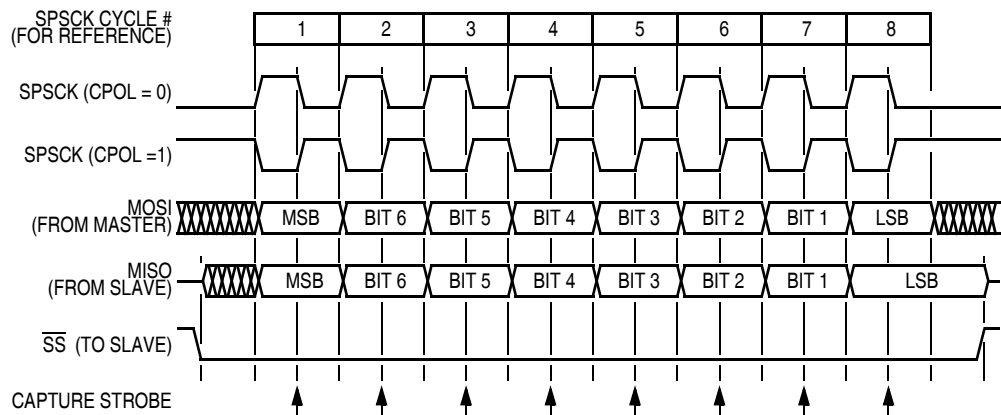
When  $CPHA = 0$  for a slave, the falling edge of  $\overline{SS}$  indicates the beginning of the transmission. This causes the SPI to leave its idle state and begin driving the MISO pin with the MSB of its data. Once the transmission begins, no new data is allowed into the shift register from the transmit data register. Therefore, the SPI data register of the slave

## Serial Peripheral Interface Module (SPI)

must be loaded with transmit data before the falling edge of  $\overline{SS}$ . Any data written after the falling edge is stored in the transmit data register and transferred to the shift register after the current transmission.

### 13.6.3 Transmission Format When CPHA = 1

**Figure 13-6** shows an SPI transmission in which CPHA is logic 1. The figure should not be used as a replacement for data sheet parametric information. Two waveforms are shown for SPSCCK: one for CPOL = 0 and another for CPOL = 1. The diagram may be interpreted as a master or slave timing diagram since the serial clock (SPSCCK), master in/slave out (MISO), and master out/slave in (MOSI) pins are directly connected between the master and the slave. The MISO signal is the output from the slave, and the MOSI signal is the output from the master. The  $\overline{SS}$  line is the slave select input to the slave. The slave SPI drives its MISO output only when its slave select input ( $\overline{SS}$ ) is at logic 0, so that only the selected slave drives to the master. The  $\overline{SS}$  pin of the master is not shown but is assumed to be inactive. The  $\overline{SS}$  pin of the master must be high or must be reconfigured as general-purpose I/O not affecting the SPI. (See **13.8.2 Mode Fault Error**.) When CPHA = 1, the master begins driving its MOSI pin on the first SPSCCK edge. Therefore the slave uses the first SPSCCK edge as a start transmission signal. The  $\overline{SS}$  pin can remain low between transmissions. This format may be preferable in systems having only one master and only one slave driving the MISO data line.



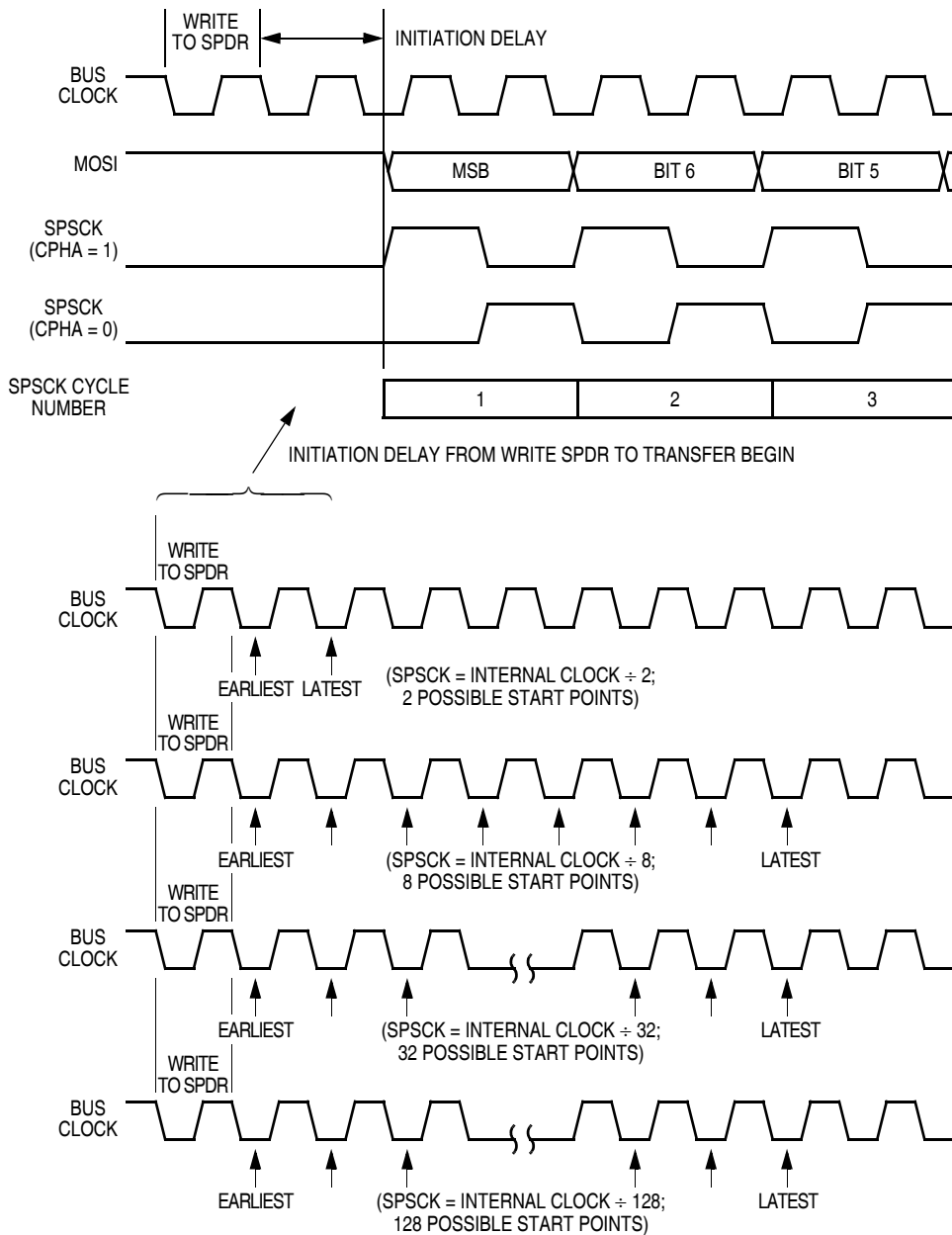
**Figure 13-6. Transmission Format (CPHA = 1)**

When  $CPHA = 1$  for a slave, the first edge of the SPSCCK indicates the beginning of the transmission. This causes the SPI to leave its idle state and begin driving the MISO pin with the MSB of its data. Once the transmission begins, no new data is allowed into the shift register from the transmit data register. Therefore, the SPI data register of the slave must be loaded with transmit data before the first edge of SPSCCK. Any data written after the first edge is stored in the transmit data register and transferred to the shift register after the current transmission.

#### 13.6.4 Transmission Initiation Latency

When the SPI is configured as a master ( $SPMSTR = 1$ ), writing to the SPDR starts a transmission.  $CPHA$  has no effect on the delay to the start of the transmission, but it does affect the initial state of the SPSCCK signal. When  $CPHA = 0$ , the SPSCCK signal remains inactive for the first half of the first SPSCCK cycle. When  $CPHA = 1$ , the first SPSCCK cycle begins with an edge on the SPSCCK line from its inactive to its active level. The SPI clock rate (selected by  $SPR1:SPR0$ ) affects the delay from the write to SPDR and the start of the SPI transmission. (See [Figure 13-7](#).) The internal SPI clock in the master is a free-running derivative of the internal MCU clock. To conserve power, it is enabled only when both the SPE and SPMSTR bits are set. SPSCCK edges occur halfway through the low time of the internal MCU clock. Since the SPI clock is free-running, it is uncertain where the write to the SPDR occurs relative to the slower SPSCCK. This uncertainty causes the variation in the initiation delay shown in [Figure 13-7](#). This delay is no longer than a single SPI bit time. That is, the maximum delay is two MCU bus cycles for DIV2, eight MCU bus cycles for DIV8, 32 MCU bus cycles for DIV32, and 128 MCU bus cycles for DIV128.

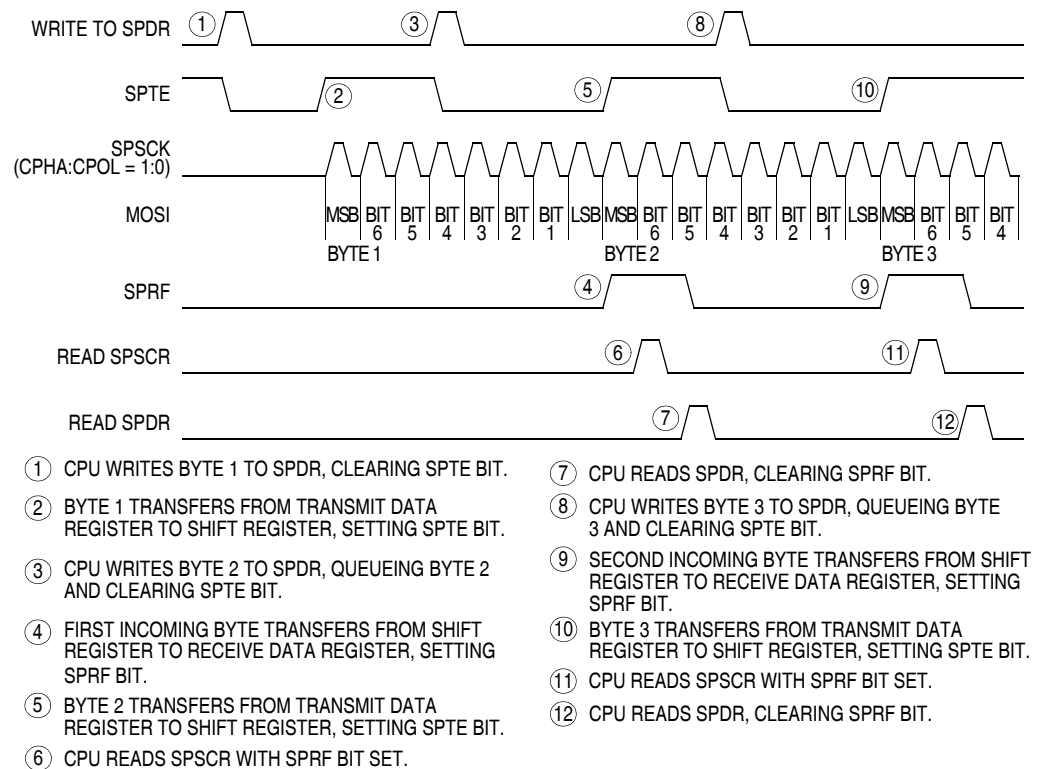
# Serial Peripheral Interface Module (SPI)



**Figure 13-7. Transmission Start Delay (Master)**

## 13.7 Queuing Transmission Data

The double-buffered transmit data register allows a data byte to be queued and transmitted. For an SPI configured as a master, a queued data byte is transmitted immediately after the previous transmission has completed. The SPI transmitter empty flag (SPTE) indicates when the transmit data buffer is ready to accept new data. Write to the transmit data register only when the SPTE bit is high. **Figure 13-8** shows the timing associated with doing back-to-back transmissions with the SPI (SPSCK has CPHA: CPOL = 1:0).



**Figure 13-8. SPRF/SPTE CPU Interrupt Timing**

The transmit data buffer allows back-to-back transmissions without the slave precisely timing its writes between transmissions as in a system with a single data buffer. Also, if no new data is written to the data buffer, the last value contained in the shift register is the next data word to be transmitted.

For an idle master or idle slave that has no data loaded into its transmit buffer, the SPTE is set again no more than two bus cycles after the transmit buffer empties into the shift register. This allows the user to queue up a 16-bit value to send. For an already active slave, the load of the shift register cannot occur until the transmission is completed. This implies that a back-to-back write to the transmit data register is not possible. The SPTE indicates when the next write can occur.

### 13.8 Error Conditions

The following flags signal SPI error conditions:

- Overflow (OVRF) — Failing to read the SPI data register before the next full byte enters the shift register sets the OVRF bit. The new byte does not transfer to the receive data register, and the unread byte still can be read. OVRF is in the SPI status and control register.
- Mode fault error (MODF) — The MODF bit indicates that the voltage on the slave select pin ( $\overline{SS}$ ) is inconsistent with the mode of the SPI. MODF is in the SPI status and control register.

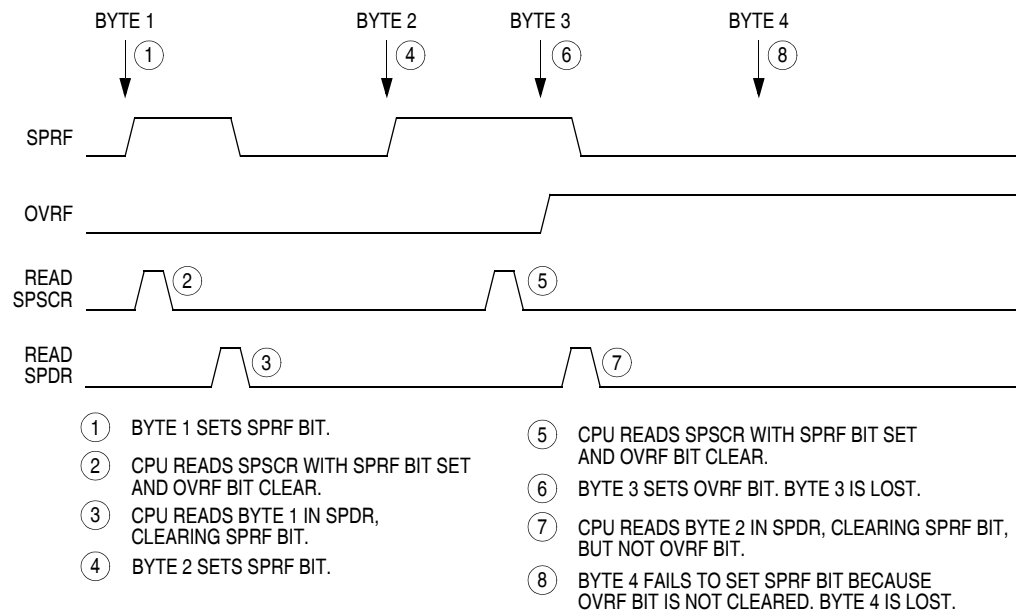
#### 13.8.1 Overflow Error

The overflow flag (OVRF) becomes set if the receive data register still has unread data from a previous transmission when the capture strobe of bit 1 of the next transmission occurs. The bit 1 capture strobe occurs in the middle of SPSCCK cycle 7. (See [Figure 13-4](#) and [Figure 13-6](#).) If an overflow occurs, all data received after the overflow and before the OVRF bit is cleared does not transfer to the receive data register and does not set the SPI receiver full bit (SPRF). The unread data that transferred to the receive data register before the overflow occurred can still be read. Therefore, an overflow error always indicates the loss of data. Clear the overflow flag by reading the SPI status and control register and then reading the SPI data register.



OVRF generates a receiver/error CPU interrupt request if the error interrupt enable bit (ERRIE) is also set. When the DMAS bit is low, the SPRF, MODF, and OVRF interrupts share the same CPU interrupt vector. (See [Figure 13-11](#).) It is not possible to enable MODF or OVRF individually to generate a receiver/error CPU interrupt request. However, leaving MODFEN low prevents MODF from being set.

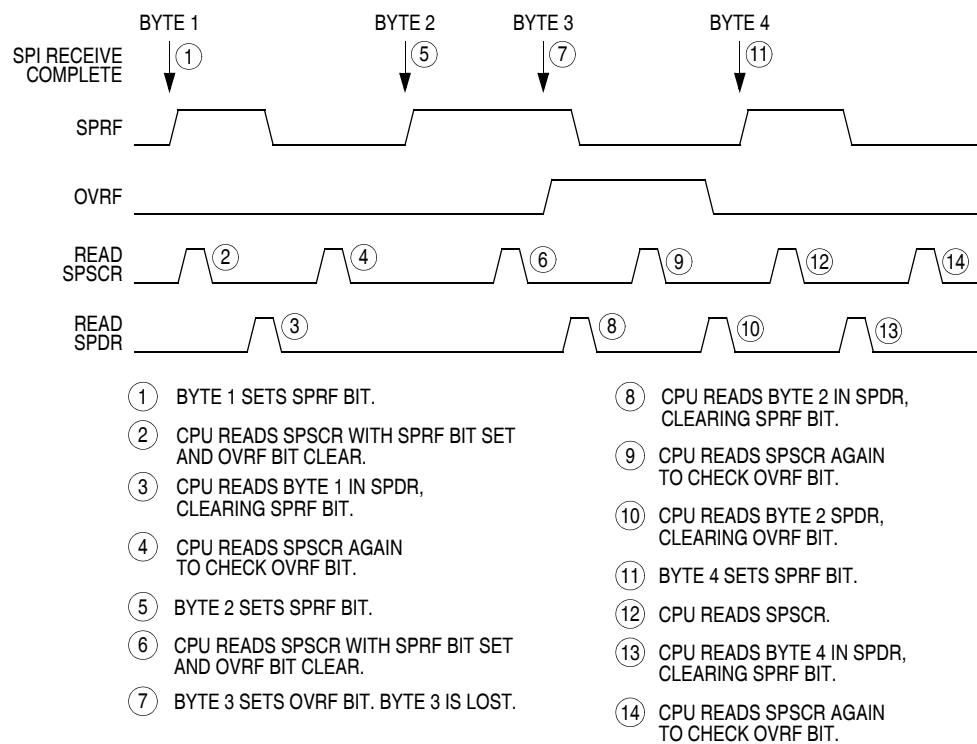
If the CPU SPRF interrupt is enabled and the OVRF interrupt is not, watch for an overflow condition. [Figure 13-9](#) shows how it is possible to miss an overflow. The first part of [Figure 13-9](#) shows how it is possible to read the SPSCR and SPDR to clear the SPRF without problems. However, as illustrated by the second transmission example, the OVRF bit can be set in between the time that SPSCR and SPDR are read.



**Figure 13-9. Missed Read of Overflow Condition**

## Serial Peripheral Interface Module (SPI)

In this case, an overflow can easily be missed. Since no more SPRF interrupts can be generated until this OVRF is serviced, it is not obvious that bytes are being lost as more transmissions are completed. To prevent this, either enable the OVRF interrupt or do another read of the SPSCR following the read of the SPDR. This ensures that the OVRF was not set before the SPRF was cleared and that future transmissions can set the SPRF bit. **Figure 13-10** illustrates this process. Generally, to avoid this second SPSCR read, enable the OVRF to the CPU by setting the ERRIE bit.



**Figure 13-10. Clearing SPRF When OVRF Interrupt Is Not Enabled**

### 13.8.2 Mode Fault Error

Setting the SPMSTR bit selects master mode and configures the SPSCCK and MOSI pins as outputs and the MISO pin as an input. Clearing SPMSTR selects slave mode and configures the SPSCCK and MOSI pins as inputs and the MISO pin as an output. The mode fault bit, MODF, becomes set any time the state of the slave select pin,  $\overline{SS}$ , is inconsistent with the mode selected by SPMSTR. To prevent SPI pin contention and damage to the MCU, a mode fault error occurs if:

- The  $\overline{SS}$  pin of a slave SPI goes high during a transmission
- The  $\overline{SS}$  pin of a master SPI goes low at any time.

For the MODF flag to be set, the mode fault error enable bit (MODFEN) must be set. Clearing the MODFEN bit does not clear the MODF flag but does prevent MODF from being set again after MODF is cleared.

MODF generates a receiver/error CPU interrupt request if the error interrupt enable bit (ERRIE) is also set. When the DMAS bit is low, the SPRF, MODF, and OVRF interrupts share the same CPU interrupt vector. (See [Figure 13-11](#).) It is not possible to enable MODF or OVRF individually to generate a receiver/error CPU interrupt request. However, leaving MODFEN low prevents MODF from being set.

In a master SPI with the mode fault enable bit (MODFEN) set, the mode fault flag (MODF) is set if  $\overline{SS}$  goes to logic 0. A mode fault in a master SPI causes the following events to occur:

- If ERRIE = 1, the SPI generates an SPI receiver/error CPU interrupt request.
- The SPE bit is cleared.
- The SPTE bit is set.
- The SPI state counter is cleared.
- The data direction register of the shared I/O port regains control of port drivers.

**NOTE:** *To prevent bus contention with another master SPI after a mode fault error, clear all SPI bits of the data direction register of the shared I/O port before enabling the SPI.*

When configured as a slave ( $SPMSTR = 0$ ), the  $MODF$  flag is set if  $\overline{SS}$  goes high during a transmission. When  $CPHA = 0$ , a transmission begins when  $\overline{SS}$  goes low and ends once the incoming  $SPSCK$  goes back to its idle level following the shift of the eighth data bit. When  $CPHA = 1$ , the transmission begins when the  $SPSCK$  leaves its idle level and  $\overline{SS}$  is already low. The transmission continues until the  $SPSCK$  returns to its idle level following the shift of the last data bit. (See [13.6 Transmission Formats](#).)

**NOTE:** *Setting the  $MODF$  flag does not clear the  $SPMSTR$  bit. The  $SPMSTR$  bit has no function when  $SPE = 0$ . Reading  $SPMSTR$  when  $MODF = 1$  shows the difference between a  $MODF$  occurring when the SPI is a master and when it is a slave.*

*When  $CPHA = 0$ , a  $MODF$  occurs if a slave is selected ( $\overline{SS}$  is at logic 0) and later unselected ( $\overline{SS}$  is at logic 1) even if no  $SPSCK$  is sent to that slave. This happens because  $\overline{SS}$  at logic 0 indicates the start of the transmission ( $MISO$  driven out with the value of  $MSB$ ) for  $CPHA = 0$ . When  $CPHA = 1$ , a slave can be selected and then later unselected with no transmission occurring. Therefore,  $MODF$  does not occur since a transmission was never begun.*

In a slave SPI ( $MSTR = 0$ ), the  $MODF$  bit generates an SPI receiver/error CPU interrupt request if the  $ERRIE$  bit is set. The  $MODF$  bit does not clear the  $SPE$  bit or reset the SPI in any way. Software can abort the SPI transmission by clearing the  $SPE$  bit of the slave.

**NOTE:** *A logic 1 voltage on the  $\overline{SS}$  pin of a slave SPI puts the  $MISO$  pin in a high impedance state. Also, the slave SPI ignores all incoming  $SPSCK$  clocks, even if it was already in the middle of a transmission.*

To clear the  $MODF$  flag, read the  $SPSCR$  with the  $MODF$  bit set and then write to the  $SPCR$  register. This entire clearing mechanism must occur with no  $MODF$  condition existing or else the flag is not cleared.

## 13.9 Interrupts

Four SPI status flags can be enabled to generate CPU interrupt requests:

**Table 13-2. SPI Interrupts**

Flag	Request
SPTIE (Transmitter Empty)	SPI Transmitter CPU Interrupt Request (DMAS = 0, SPTIE = 1, SPE = 1)
SPRF (ReceiverFull)	SPI Receiver CPU Interrupt Request (DMAS = 0, SPRIE = 1)
OVRF (Overflow)	SPI Receiver/Error Interrupt Request (ERRIE = 1)
MODF (Mode Fault)	SPI Receiver/Error Interrupt Request (ERRIE = 1)

Reading the SPI status and control register with SPRF set and then reading the receive data register clears SPRF. The clearing mechanism for the SPTIE flag is always just a write to the transmit data register.

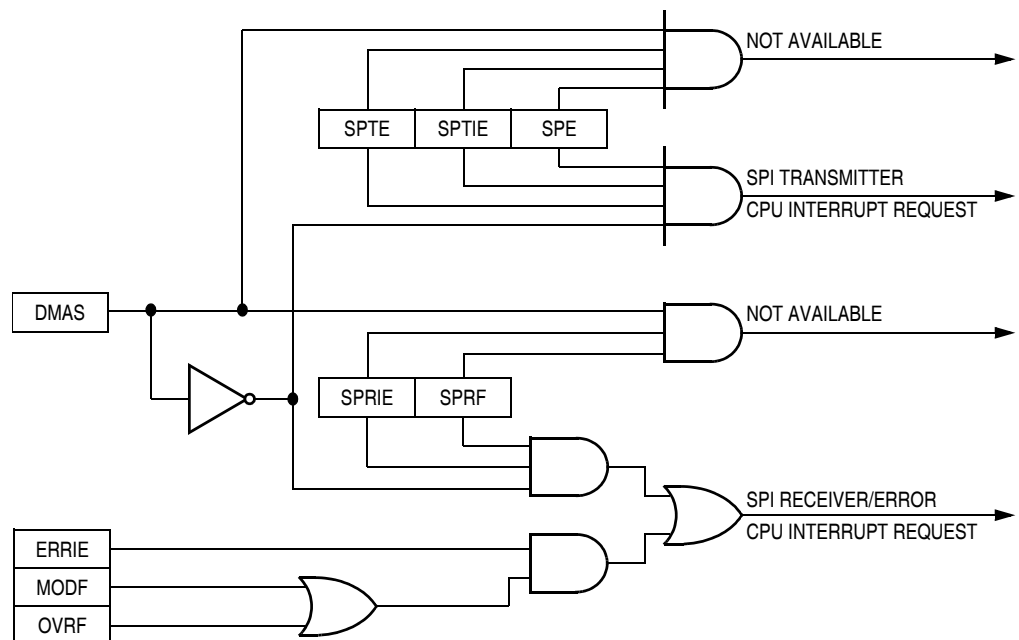
The SPI transmitter interrupt enable bit (SPTIE) enables the SPTIE flag to generate transmitter CPU interrupt requests, provided that the SPI is enabled (SPE = 1).

The SPI receiver interrupt enable bit (SPRIE) enables the SPRF bit to generate receiver CPU interrupt requests, regardless of the state of the SPE bit. (See [Figure 13-11](#).)

The error interrupt enable bit (ERRIE) enables both the MODF and OVRF bits to generate a receiver/error CPU interrupt request.

The mode fault enable bit (MODFEN) can prevent the MODF flag from being set so that only the OVRF bit is enabled by the ERRIE bit to generate receiver/error CPU interrupt requests.

## Serial Peripheral Interface Module (SPI)



**Figure 13-11. SPI Interrupt Request Generation**

The following sources in the SPI status and control register can generate CPU interrupt requests:

- SPI receiver full bit (SPRF) — The SPRF bit becomes set every time a byte transfers from the shift register to the receive data register. If the SPI receiver interrupt enable bit, SPRIE, is also set, SPRF generates an SPI receiver/error CPU interrupt request.
- SPI transmitter empty (SPTIE) — The SPTIE bit becomes set every time a byte transfers from the transmit data register to the shift register. If the SPI transmit interrupt enable bit, SPTIE, is also set, SPTIE generates an SPTIE CPU interrupt request.

## 13.10 Resetting the SPI

Any system reset completely resets the SPI. Partial resets occur whenever the SPI enable bit (SPE) is low. Whenever SPE is low, the following occurs:

- The SPTE flag is set
- Any transmission currently in progress is aborted
- The shift register is cleared
- The SPI state counter is cleared, making it ready for a new complete transmission
- All the SPI port logic is defaulted back to being general purpose I/O.

The following items are reset only by a system reset:

- All control bits in the SPCR register
- All control bits in the SPSCR register (MODFEN, ERRIE, SPR1, and SPR0)
- The status flags SPRF, OVRF, and MODF

By not resetting the control bits when SPE is low, the user can clear SPE between transmissions without having to set all control bits again when SPE is set back high for the next transmission.

By not resetting the SPRF, OVRF, and MODF flags, the user can still service these interrupts after the SPI has been disabled. The user can disable the SPI by writing 0 to the SPE bit. The SPI can also be disabled by a mode fault occurring in an SPI that was configured as a master with the MODFEN bit set.

### 13.11 Low-Power Mode

The WAIT instruction puts the MCU in a low-power-consumption standby mode.

The SPI module remains active after the execution of a WAIT instruction. In wait mode the SPI module registers are not accessible by the CPU. Any enabled CPU interrupt request from the SPI module can bring the MCU out of wait mode.

If SPI module functions are not required during wait mode, reduce power consumption by disabling the SPI module before executing the WAIT instruction.

### 13.12 SPI During Break Interrupts

The system integration module (SIM) controls whether status bits in other modules can be cleared during the break state. The BCFE bit in the SIM break flag control register (SBFCR) enables software to clear status bits during the break state. (See [Section 7. System Integration Module \(SIM\)](#).)

To allow software to clear status bits during a break interrupt, write a logic 1 to the BCFE bit. If a status bit is cleared during the break state, it remains cleared when the MCU exits the break state.

To protect status bits during the break state, write a logic 0 to the BCFE bit. With BCFE at logic 0 (its default state), software can read and write I/O registers during the break state without affecting status bits. Some status bits have a two-step read/write clearing procedure. If software does the first step on such a bit before the break, the bit cannot change during the break state as long as BCFE is at logic 0. After the break, doing the second step clears the status bit.

Since the SPTE bit cannot be cleared during a break with the BCFE bit cleared, a write to the transmit data register in break mode does not initiate a transmission, nor is this data transferred into the shift register. Therefore, a write to the SPDR in break mode with the BCFE bit cleared has no effect.



## 13.13 I/O Signals

The SPI module has five I/O pins and shares four of them with a parallel I/O port.

- MISO — Data received
- MOSI — Data transmitted
- SPSCK — Serial clock
- $\overline{SS}$  — Slave select
- CGND — Clock ground

The SPI has limited inter-integrated circuit (I<sup>2</sup>C) capability (requiring software support) as a master in a single-master environment. To communicate with I<sup>2</sup>C peripherals, MOSI becomes an open-drain output when the SPWOM bit in the SPI control register is set. In I<sup>2</sup>C communication, the MOSI and MISO pins are connected to a bidirectional pin from the I<sup>2</sup>C peripheral and through a pullup resistor to V<sub>DD</sub>.

### 13.13.1 MISO (Master In/Slave Out)

MISO is one of the two SPI module pins that transmits serial data. In full duplex operation, the MISO pin of the master SPI module is connected to the MISO pin of the slave SPI module. The master SPI simultaneously receives data on its MISO pin and transmits data from its MOSI pin.

Slave output data on the MISO pin is enabled only when the SPI is configured as a slave. The SPI is configured as a slave when its SPMSTR bit is logic 0 and its  $\overline{SS}$  pin is at logic 0. To support a multiple-slave system, a logic 1 on the  $\overline{SS}$  pin puts the MISO pin in a high-impedance state.

When enabled, the SPI controls data direction of the MISO pin regardless of the state of the data direction register of the shared I/O port.

### 13.13.2 MOSI (Master Out/Slave In)

MOSI is one of the two SPI module pins that transmits serial data. In full duplex operation, the MOSI pin of the master SPI module is connected to the MOSI pin of the slave SPI module. The master SPI simultaneously transmits data from its MOSI pin and receives data on its MISO pin.

When enabled, the SPI controls data direction of the MOSI pin regardless of the state of the data direction register of the shared I/O port.

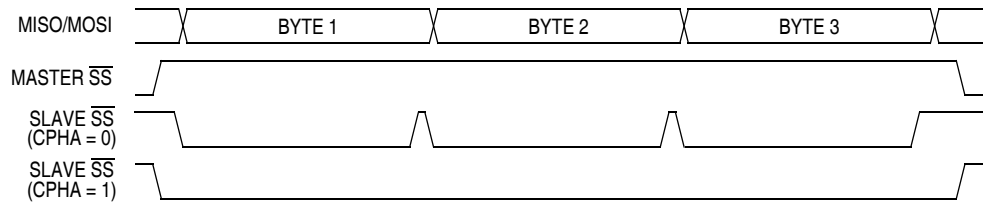
### 13.13.3 SPCK (Serial Clock)

The serial clock synchronizes data transmission between master and slave devices. In a master MCU, the SPCK pin is the clock output. In a slave MCU, the SPCK pin is the clock input. In full duplex operation, the master and slave MCUs exchange a byte of data in eight serial clock cycles.

When enabled, the SPI controls data direction of the SPCK pin regardless of the state of the data direction register of the shared I/O port.

### 13.13.4 $\overline{SS}$ (Slave Select)

The  $\overline{SS}$  pin has various functions depending on the current state of the SPI. For an SPI configured as a slave, the  $\overline{SS}$  is used to select a slave. For CPHA = 0, the  $\overline{SS}$  is used to define the start of a transmission. (See [13.6 Transmission Formats](#).) Since it is used to indicate the start of a transmission, the  $\overline{SS}$  must be toggled high and low between each byte transmitted for the CPHA = 0 format. However, it can remain low between transmissions for the CPHA = 1 format. See [Figure 13-12](#).



**Figure 13-12. CPHA/ $\overline{SS}$  Timing**

When an SPI is configured as a slave, the  $\overline{SS}$  pin is always configured as an input. It cannot be used as a general purpose I/O regardless of the state of the MODFEN control bit. However, the MODFEN bit can still prevent the state of the  $\overline{SS}$  from creating a MODF error. (See [13.14.2 SPI Status and Control Register](#).)

**NOTE:** *A logic 1 voltage on the  $\overline{SS}$  pin of a slave SPI puts the MISO pin in a high-impedance state. The slave SPI ignores all incoming SPSCCK clocks, even if it was already in the middle of a transmission.*

When an SPI is configured as a master, the  $\overline{SS}$  input can be used in conjunction with the MODF flag to prevent multiple masters from driving MOSI and SPSCCK. (See [13.8.2 Mode Fault Error](#).) For the state of the  $\overline{SS}$  pin to set the MODF flag, the MODFEN bit in the SPSCCK register must be set. If the MODFEN bit is low for an SPI master, the  $\overline{SS}$  pin can be used as a general purpose I/O under the control of the data direction register of the shared I/O port. With MODFEN high, it is an input-only pin to the SPI regardless of the state of the data direction register of the shared I/O port.

The CPU can always read the state of the  $\overline{SS}$  pin by configuring the appropriate pin as an input and reading the port data register. (See [Table 13-3](#).)

**Table 13-3. SPI Configuration**

SPE	SPMSTR	MODFEN	SPI Configuration	State of $\overline{SS}$ Logic
0	X <sup>(1)</sup>	X	Not Enabled	General-purpose I/O; $\overline{SS}$ ignored by SPI
1	0	X	Slave	Input-only to SPI
1	1	0	Master without MODF	General-purpose I/O; $\overline{SS}$ ignored by SPI
1	1	1	Master with MODF	Input-only to SPI

1. X = don't care

## 13.13.5 CGND (Clock Ground)

CGND is the ground return for the serial clock pin, SPSCCK, and the ground for the port output buffers. To reduce the ground return path loop and minimize radio frequency (RF) emissions, connect the ground pin of the slave to the CGND pin of the master.

## 13.14 I/O Registers

Three registers control and monitor SPI operation:

- SPI control register (SPCR)
- SPI status and control register (SPSCR)
- SPI data register (SPDR)


### 13.14.1 SPI Control Register

The SPI control register does the following:

- Enables SPI module interrupt requests
- Selects CPU interrupt requests
- Configures the SPI module as master or slave
- Selects serial clock polarity and phase
- Configures the SPSCK, MOSI, and MISO pins as open-drain outputs
- Enables the SPI module

Address: \$001B

	Bit 7	6	5	4	3	2	1	Bit 0
Read:	SPRIE	DMAS	SPMSTR	CPOL	CPHA	SPWOM	SPE	SPTIE
Write:								
Reset:	0	0	1	0	1	0	0	0

 = Unimplemented

**Figure 13-13. SPI Control Register (SPCR)**

#### SPRIE — SPI Receiver Interrupt Enable Bit

This read/write bit enables CPU interrupt requests generated by the SPRF bit. The SPRF bit is set when a byte transfers from the shift register to the receive data register. Reset clears the SPRIE bit.

1 = SPRF CPU interrupt requests

0 = SPRF CPU interrupt requests

#### DMAS —DMA Select Bit

This read-only bit has no effect on this version of the SPI. This bit always reads as a 0.

0 = SPRF DMA and SPTE DMA service requests disabled  
(SPRF CPU and SPTE CPU interrupt requests enabled)

#### SPMSTR — SPI Master Bit

## Serial Peripheral Interface Module (SPI)

This read/write bit selects master mode operation or slave mode operation. Reset sets the SPMSTR bit.

- 1 = Master mode
- 0 = Slave mode

### CPOL — Clock Polarity Bit

This read/write bit determines the logic state of the SPSCCK pin between transmissions. (Figure 13-4 and Figure 13-6.) To transmit data between SPI modules, the SPI modules must have identical CPOL values. Reset clears the CPOL bit.

### CPHA — Clock Phase Bit

This read/write bit controls the timing relationship between the serial clock and SPI data. (See Figure 13-4 and Figure 13-6.) To transmit data between SPI modules, the SPI modules must have identical CPHA values. When CPHA = 0, the  $\overline{SS}$  pin of the slave SPI module must be set to logic 1 between bytes. (See Figure 13-12.) Reset sets the CPHA bit.

### SPWOM — SPI Wired-OR Mode Bit

This read/write bit disables the pull-up devices on pins SPSCCK, MOSI, and MISO so that those pins become open-drain outputs.

- 1 = Wired-OR SPSCCK, MOSI, and MISO pins
- 0 = Normal push-pull SPSCCK, MOSI, and MISO pins

### SPE — SPI Enable

This read/write bit enables the SPI module. Clearing SPE causes a partial reset of the SPI. (See 13.10 Resetting the SPI.) Reset clears the SPE bit.

- 1 = SPI module enabled
- 0 = SPI module disabled

### SPTIE— SPI Transmit Interrupt Enable

This read/write bit enables CPU interrupt requests generated by the SPTIE bit. SPTIE is set when a byte transfers from the transmit data register to the shift register. Reset clears the SPTIE bit.

- 1 = SPTIE CPU interrupt requests enabled
- 0 = SPTIE CPU interrupt requests disabled

### 13.14.2 SPI Status and Control Register

The SPI status and control register contains flags to signal the following conditions:


- Receive data register full
- Failure to clear SPRF bit before next byte is received (overflow error)
- Inconsistent logic level on  $\overline{SS}$  pin (mode fault error)
- Transmit data register empty

The SPI status and control register also contains bits that perform the following functions:

- Enable error interrupts
- Enable mode fault error detection
- Select master SPI baud rate

Address: \$001C

	Bit 7	6	5	4	3	2	1	Bit 0
Read:	SPRF	ERRIE	OVRF	MODF	SPTF	MODFEN	SPR1	SPR0
Write:								
Reset:	0	0	0	0	1	0	0	0

 = Unimplemented

**Figure 13-14. SPI Status and Control Register (SPSCR)**

#### SPRF — SPI Receiver Full Bit

This clearable, read-only flag is set each time a byte transfers from the shift register to the receive data register. SPRF generates a CPU interrupt request if the SPRIE bit in the SPI control register is set also. During an SPRF CPU interrupt, the CPU clears SPRF by reading the SPI status and control register with SPRF set and then reading the SPI data register.

Reset clears the SPRF bit.

- 1 = Receive data register full
- 0 = Receive data register not full

### ERRIE — Error Interrupt Enable Bit

This read/write bit enables the MODF and OVRF bits to generate CPU interrupt requests. Reset clears the ERRIE bit.

1 = MODF and OVRF can generate CPU interrupt requests

0 = MODF and OVRF cannot generate CPU interrupt requests

### OVRF — Overflow Bit

This clearable, read-only flag is set if software does not read the byte in the receive data register before the next full byte enters the shift register. In an overflow condition, the byte already in the receive data register is unaffected, and the byte that shifted in last is lost. Clear the OVRF bit by reading the SPI status and control register with OVRF set and then reading the receive data register. Reset clears the OVRF bit.

1 = Overflow

0 = No overflow

### MODF — Mode Fault Bit

This clearable, read-only flag is set in a slave SPI if the  $\overline{SS}$  pin goes high during a transmission with the MODFEN bit set. In a master SPI, the MODF flag is set if the  $\overline{SS}$  pin goes low at any time with the MODFEN bit set. Clear the MODF bit by reading the SPI status and control register (SPSCR) with MODF set and then writing to the SPI control register (SPCR). Reset clears the MODF bit.

1 =  $\overline{SS}$  pin at inappropriate logic level

0 =  $\overline{SS}$  pin at appropriate logic level

### SPTE — SPI Transmitter Empty Bit

This clearable, read-only flag is set each time the transmit data register transfers a byte into the shift register. SPTE generates an SPTE CPU interrupt request if the SPTIE bit in the SPI control register is set also.

**NOTE:** Do not write to the SPI data register unless the SPTE bit is high.

During an SPTE CPU interrupt, the CPU clears the SPTE bit by writing to the transmit data register.

Reset sets the SPTE bit.

1 = Transmit data register empty

0 = Transmit data register not empty



**MODFEN — Mode Fault Enable Bit**

This read/write bit, when set to 1, allows the MODF flag to be set. If the MODF flag is set, clearing the MODFEN does not clear the MODF flag. If the SPI is enabled as a master and the MODFEN bit is low, then the  $\overline{SS}$  pin is available as a general purpose I/O.

If the MODFEN bit is set, then this pin is not available as a general purpose I/O. When the SPI is enabled as a slave, the  $\overline{SS}$  pin is not available as a general purpose I/O regardless of the value of MODFEN. (See [13.13.4 SS \(Slave Select\)](#).)

If the MODFEN bit is low, the level of the  $\overline{SS}$  pin does not affect the operation of an enabled SPI configured as a master. For an enabled SPI configured as a slave, having MODFEN low only prevents the MODF flag from being set. It does not affect any other part of SPI operation. (See [13.8.2 Mode Fault Error](#).)

**SPR1 and SPR0 — SPI Baud Rate Select Bits**

In master mode, these read/write bits select one of four baud rates as shown in [Table 13-4](#). SPR1 and SPR0 have no effect in slave mode. Reset clears SPR1 and SPR0.

**Table 13-4. SPI Master Baud Rate Selection**

SPR1:SPR0	Baud Rate Divisor (BD)
00	2
01	8
10	32
11	128

Use the following formula to calculate the SPI baud rate:

$$\text{Baud rate} = \frac{\text{CGMOUT}}{2 \times \text{BD}}$$

where:

CGMOUT = base clock output of the clock generator module (CGM)

BD = baud rate divisor

## 13.14.3 SPI Data Register

The SPI data register consists of the read-only receive data register and the write-only transmit data register. Writing to the SPI data register writes data into the transmit data register. Reading the SPI data register reads data from the receive data register. The transmit data and receive data registers are separate registers that can contain different values. (See [Figure 13-1](#).)

Address: \$001D

	Bit 7	6	5	4	3	2	1	Bit 0
Read:	R7	R6	R5	R4	R3	R2	R1	R0
Write:	T7	T6	T5	T4	T3	T2	T1	T0
Reset:	Indeterminate after reset							

**Figure 13-15. SPI Data Register (SPDR)**

R7:R0/T7:T0 — Receive/Transmit Data Bits

**NOTE:** *Do not use read-modify-write instructions on the SPI data register since the register read is not the same as the register written.*

## Section 14. Serial Communications Interface Module (SCI)

### 14.1 Contents

14.2	Introduction	284
14.3	Features	284
14.4	Functional Description	285
14.4.1	Data Format	288
14.4.2	Transmitter	288
14.4.2.1	Character Length	288
14.4.2.2	Character Transmission	289
14.4.2.3	Break Characters	291
14.4.2.4	Idle Characters	291
14.4.2.5	Inversion of Transmitted Output	292
14.4.2.6	Transmitter Interrupts	292
14.4.3	Receiver	293
14.4.3.1	Character Length	294
14.4.3.2	Character Reception	294
14.4.3.3	Data Sampling	294
14.4.3.4	Framing Errors	297
14.4.3.5	Receiver Wake-Up	297
14.4.3.6	Receiver Interrupts	298
14.4.3.7	Error Interrupts	298
14.5	Wait Mode	299
14.6	SCI During Break Module Interrupts	299
14.7	I/O Signals	300
14.7.1	PTF5/TxD (Transmit Data)	300
14.7.2	PTF4/RxD (Receive Data)	300

14.8	I/O Registers . . . . .	300
14.8.1	SCI Control Register 1 . . . . .	301
14.8.2	SCI Control Register 2 . . . . .	304
14.8.3	SCI Control Register 3 . . . . .	307
14.8.4	SCI Status Register 1 . . . . .	309
14.8.5	SCI Status Register 2 . . . . .	313
14.8.6	SCI Data Register . . . . .	314
14.8.7	SCI Baud Rate Register . . . . .	314

## 14.2 Introduction

This section describes the serial communications interface module (SCI, Version D), which allows high-speed asynchronous communications with peripheral devices and other MCUs.

## 14.3 Features

Features of the SCI module include:

- Full duplex operation
- Standard mark/space non-return-to-zero (NRZ) format
- 32 programmable baud rates
- Programmable 8-bit or 9-bit character length
- Separately enabled transmitter and receiver
- Separate receiver and transmitter cpu interrupt requests
- Separate receiver and transmitter
- Programmable transmitter output polarity
- Two receiver wake-up methods:
  - Idle line wake-up
  - Address mark wake-up

- Interrupt-driven operation with eight interrupt flags:
  - Transmitter empty
  - Transmission complete
  - Receiver full
  - Idle receiver input
  - Receiver overrun
  - Noise error
  - Framing error
  - Parity error
- Receiver framing error detection
- Hardware parity checking
- 1/16 bit-time noise detection

## 14.4 Functional Description

**Figure 14-1** shows the structure of the SCI module. The SCI allows full-duplex, asynchronous, NRZ serial communication among the MCU and remote devices, including other MCUs. The transmitter and receiver of the SCI operate independently, although they use the same baud rate generator. During normal operation, the CPU monitors the status of the SCI, writes the data to be transmitted, and processes received data.

# Serial Communications Interface Module (SCI)

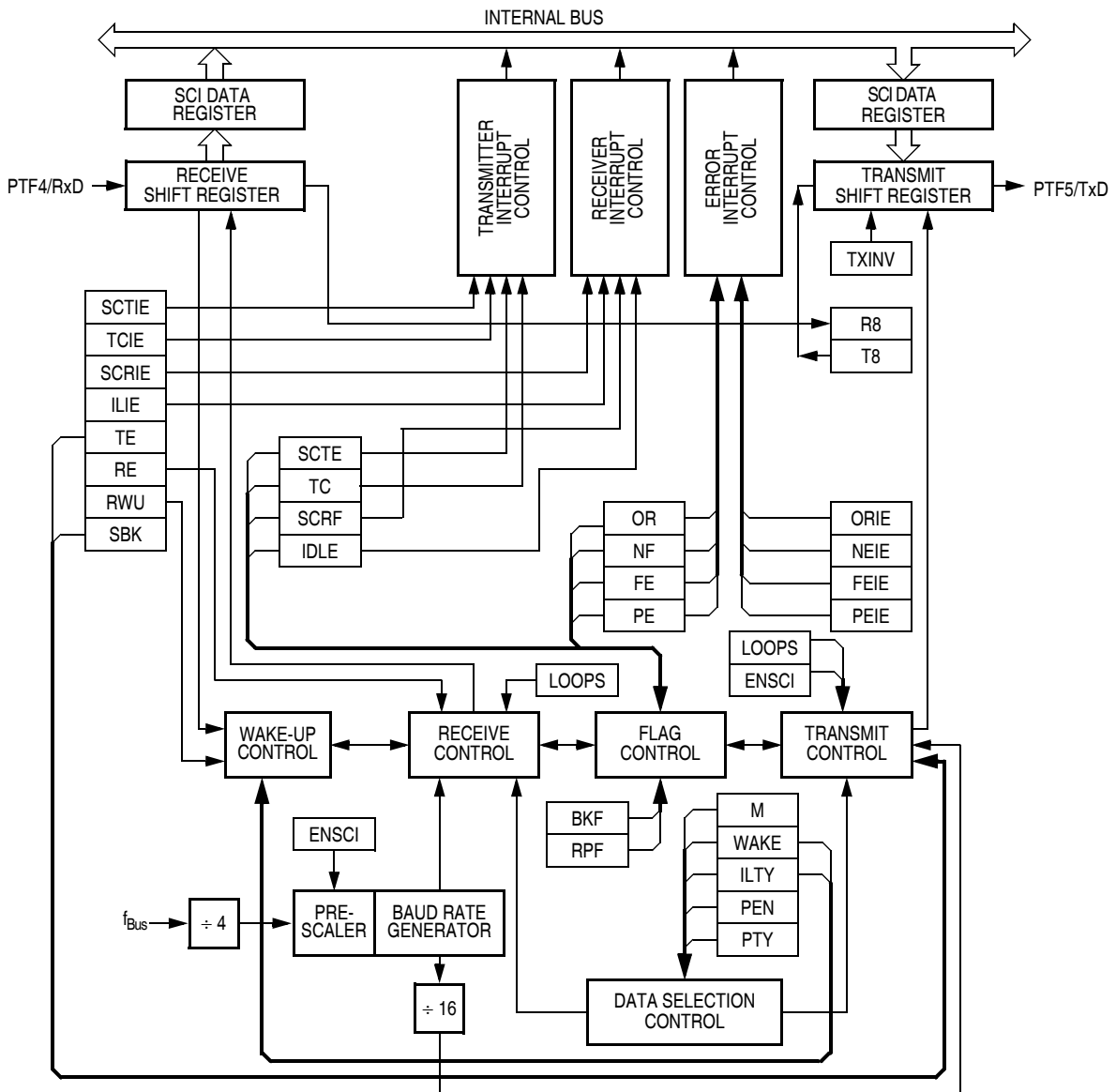


Figure 14-1. SCI Module Block Diagram

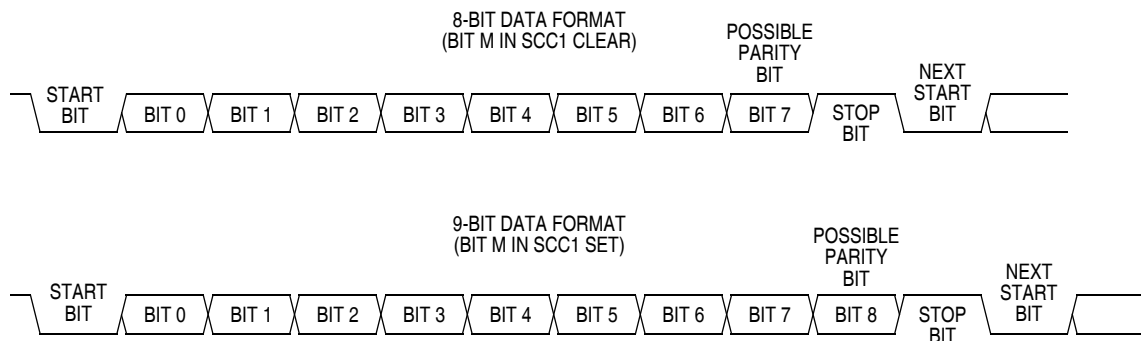
Addr.	Name	Bit 7	6	5	4	3	2	1	Bit 0	
\$0038	SCI Control Register 1 (SCC1)	Read:	LOOPS	ENSCI	TXINV	M	WAKE	ILTY	PEN	PTY
		Write:								
		Reset:	0	0	0	0	0	0	0	0
\$0039	SCI Control Register 2 (SCC2)	Read:	SCTIE	TCIE	SCRIE	ILIE	TE	RE	RWU	SBK
		Write:								
		Reset:	0	0	0	0	0	0	0	0
\$003A	SCI Control Register 3 (SCC3)	Read:	R8	T8	0	0	ORIE	NEIE	FEIE	PEIE
		Write:								
		Reset:	U	U	0	0	0	0	0	0
\$003B	SCI Status Register 1 (SCS1)	Read:	SCTE	TC	SCRf	IDLE	OR	NF	FE	PE
		Write:								
		Reset:	1	1	0	0	0	0	0	0
\$003C	SCI Status Register 2 (SCS2)	Read:							BKF	RPF
		Write:								
		Reset:	0	0	0	0	0	0	0	0
\$003D	SCI Data Register (SCDR)	Read:	Bit 7	6	5	4	3	2	1	Bit 0
		Write:								
		Reset:	Unaffected by reset							
\$003E	SCI Baud Rate Register (SCBR)	Read:			SCP1	SCP0	R	SCR2	SCR1	SCR0
		Write:								
		Reset:	0	0	0	0	0	0	0	0

= Unimplemented    
 R = Reserved    
 U = Unaffected

**Figure 14-2. SCI I/O Register Summary**

## 14.4.1 Data Format

The SCI uses the standard non-return-to-zero mark/space data format illustrated in [Figure 14-3](#).



**Figure 14-3. SCI Data Formats**

## 14.4.2 Transmitter

[Figure 14-4](#) shows the structure of the SCI transmitter.

### 14.4.2.1 Character Length

The transmitter can accommodate either 8-bit or 9-bit data. The state of the M bit in SCI control register 1 (SCC1) determines character length. When transmitting 9-bit data, bit T8 in SCI control register 3 (SCC3) is the ninth bit (bit 8).



### 14.4.2.2 Character Transmission

During an SCI transmission, the transmit shift register shifts a character out to the PTF5/TxD pin. The SCI data register (SCDR) is the write-only buffer between the internal data bus and the transmit shift register. To initiate an SCI transmission:

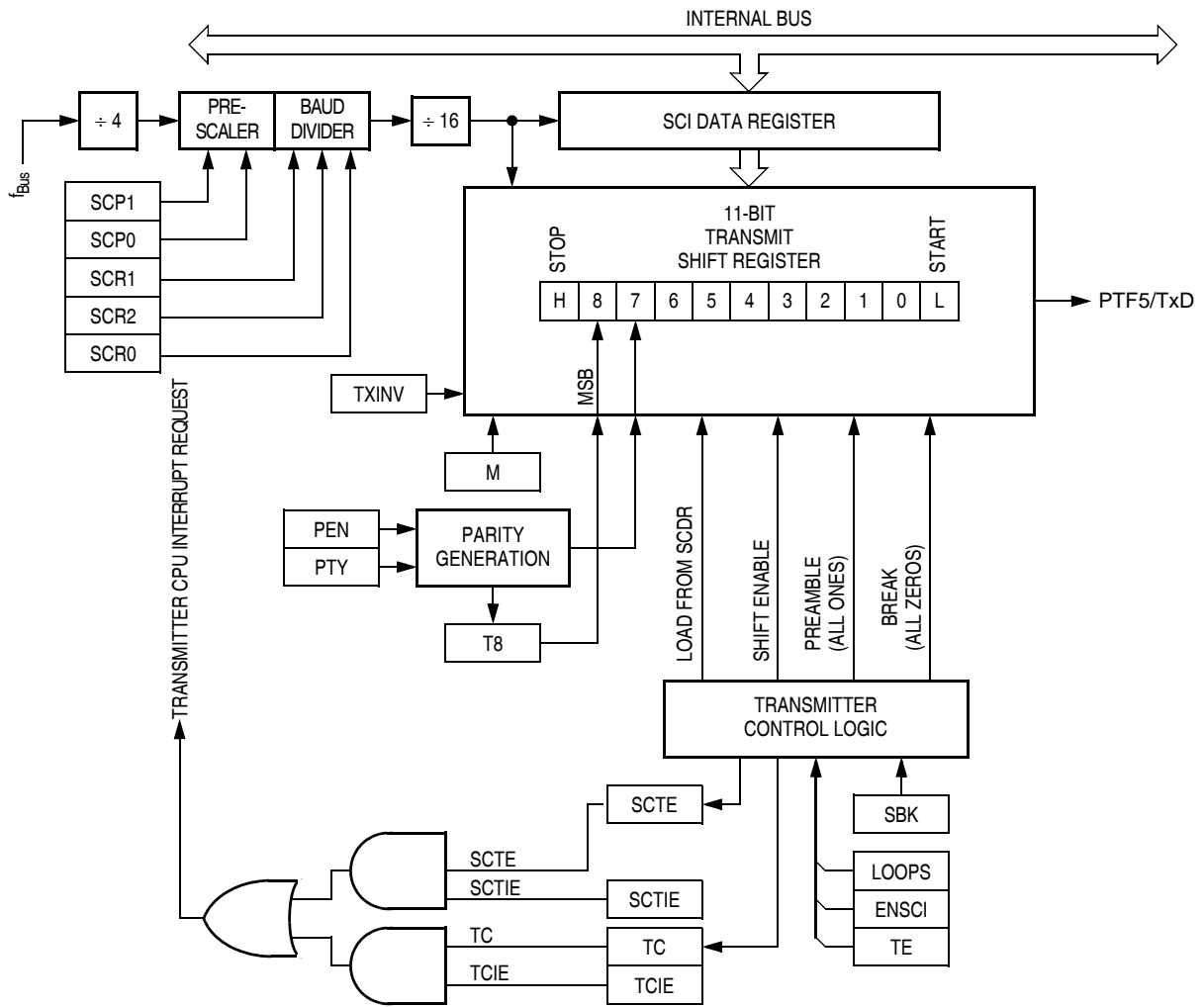
1. Enable the SCI by writing a logic 1 to the enable SCI bit (ENSCI) in SCI control register 1 (SCC1).
2. Enable the transmitter by writing a logic 1 to the transmitter enable bit (TE) in SCI control register 2 (SCC2).
3. Clear the SCI transmitter empty bit by first reading SCI status register 1 (SCS1) and then writing to the SCDR.
4. Repeat step 3 for each subsequent transmission.

At the start of a transmission, transmitter control logic automatically loads the transmit shift register with a preamble of logic 1s. After the preamble shifts out, control logic transfers the SCDR data into the transmit shift register. A logic 0 start bit automatically goes into the least significant bit position of the transmit shift register. A logic 1 stop bit goes into the most significant bit position.

The SCI transmitter empty bit, SCTE, in SCS1 becomes set when the SCDR transfers a byte to the transmit shift register. The SCTE bit indicates that the SCDR can accept new data from the internal data bus. If the SCI transmit interrupt enable bit, SCTIE, in SCC2 is also set, the SCTE bit generates a transmitter CPU interrupt request.

When the transmit shift register is not transmitting a character, the PTF5/TxD pin goes to the idle condition, logic 1. If at any time software clears the ENSCI bit in SCI control register 1 (SCC1), the transmitter and receiver relinquish control of the port F pins.

# Serial Communications Interface Module (SCI)



**Figure 14-4. SCI Transmitter**

### 14.4.2.3 Break Characters

Writing a logic 1 to the send break bit, SBK, in SCC2 loads the transmit shift register with a break character. A break character contains all logic 0s and has no start, stop, or parity bit. Break character length depends on the M bit in SCC1. As long as SBK is at logic 1, transmitter logic continuously loads break characters into the transmit shift register. After software clears the SBK bit, the shift register finishes transmitting the last break character and then transmits at least one logic 1. The automatic logic 1 at the end of a break character guarantees the recognition of the start bit of the next character.

The SCI recognizes a break character when a start bit is followed by 8 or 9 logic 0 data bits and a logic 0 where the stop bit should be. Receiving a break character has the following effects on SCI registers:

- Sets the framing error bit (FE) in SCS1
- Sets the SCI receiver full bit (SCRF) in SCS1
- Clears the SCI data register (SCDR)
- Clears the R8 bit in SCC3
- Sets the break flag bit (BKF) in SCS2
- May set the overrun (OR), noise flag (NF), parity error (PE), or reception in progress flag (RPF) bits

### 14.4.2.4 Idle Characters

An idle character contains all logic 1s and has no start, stop, or parity bit. Idle character length depends on the M bit in SCC1. The preamble is a synchronizing idle character that begins every transmission.

If the TE bit is cleared during a transmission, the PTF5/TxD pin becomes idle after completion of the transmission in progress. Clearing and then setting the TE bit during a transmission queues an idle character to be sent after the character currently being transmitted.

**NOTE:** *When queueing an idle character, return the TE bit to logic 1 before the stop bit of the current character shifts out to the PTF5/TxD pin. Setting*

*TE after the stop bit appears on PTF5/TxD causes data previously written to the SCDR to be lost.*

*A good time to toggle the TE bit is when the SCTE bit becomes set and just before writing the next byte to the SCDR.*

### 14.4.2.5 Inversion of Transmitted Output

The transmit inversion bit (TXINV) in SCI control register 1 (SCC1) reverses the polarity of transmitted data. All transmitted values, including idle, break, start, and stop bits, are inverted when TXINV is at logic 1. (See [14.8.1 SCI Control Register 1](#).)

### 14.4.2.6 Transmitter Interrupts

The following conditions can generate CPU interrupt requests from the SCI transmitter:

- SCI transmitter empty (SCTE) — The SCTE bit in SCS1 indicates that the SCDR has transferred a character to the transmit shift register. SCTE can generate a transmitter CPU interrupt request. Setting the SCI transmit interrupt enable bit, SCTIE, in SCC2 enables the SCTE bit to generate transmitter CPU interrupt requests.
- Transmission complete (TC) — The TC bit in SCS1 indicates that the transmit shift register and the SCDR are empty and that no break or idle character has been generated. The transmission complete interrupt enable bit, TCIE, in SCC2 enables the TC bit to generate transmitter CPU interrupt requests.

### 14.4.3 Receiver

Figure 14-5 shows the structure of the SCI receiver.

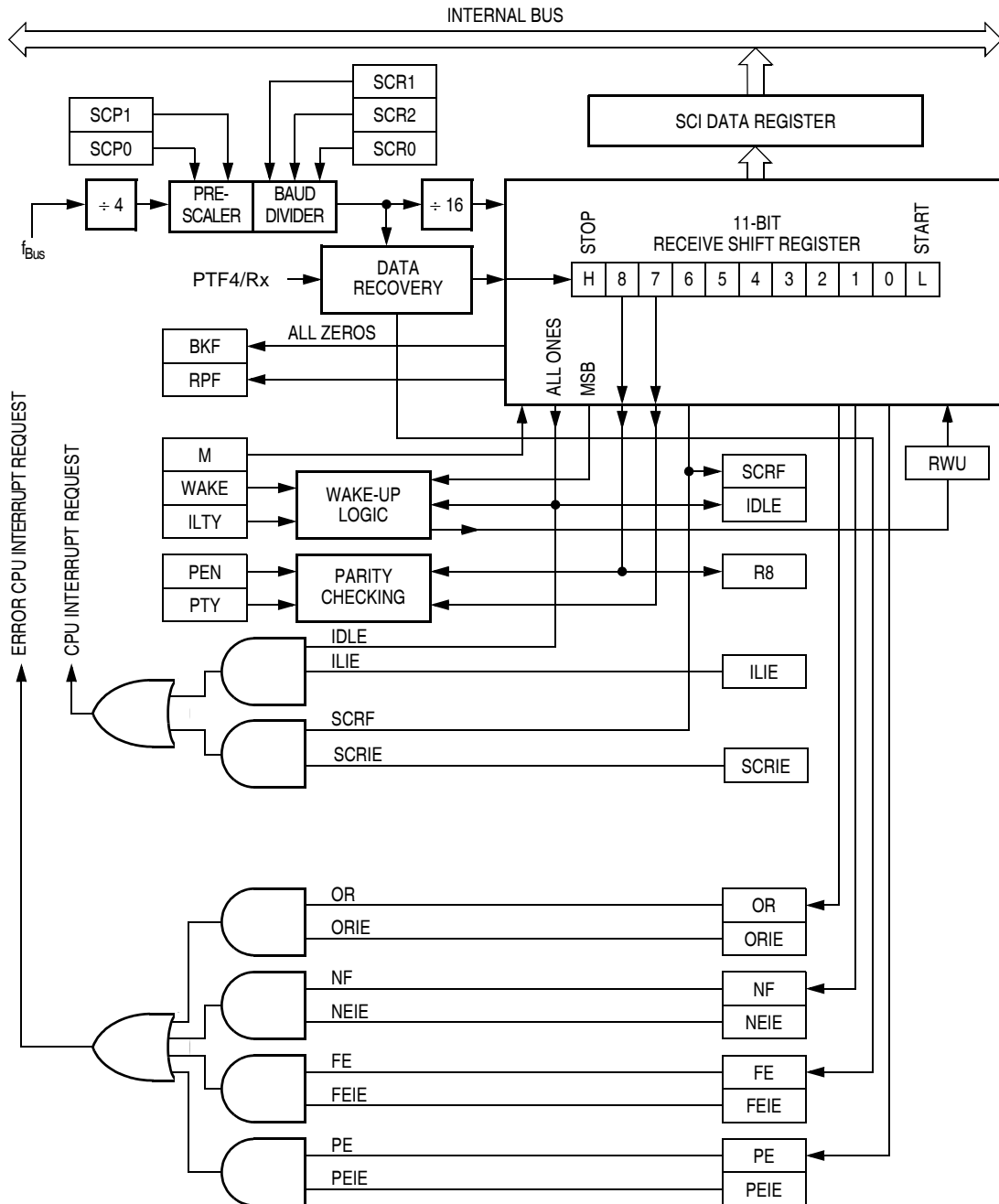


Figure 14-5. SCI Receiver Block Diagram

### 14.4.3.1 Character Length

The receiver can accommodate either 8-bit or 9-bit data. The state of the M bit in SCI control register 1 (SCC1) determines character length. When receiving 9-bit data, bit R8 in SCI control register 2 (SCC2) is the ninth bit (bit 8). When receiving 8-bit data, bit R8 is a copy of the eighth bit (bit 7).

### 14.4.3.2 Character Reception

During an SCI reception, the receive shift register shifts characters in from the PTF4/RxD pin. The SCI data register (SCDR) is the read-only buffer between the internal data bus and the receive shift register.

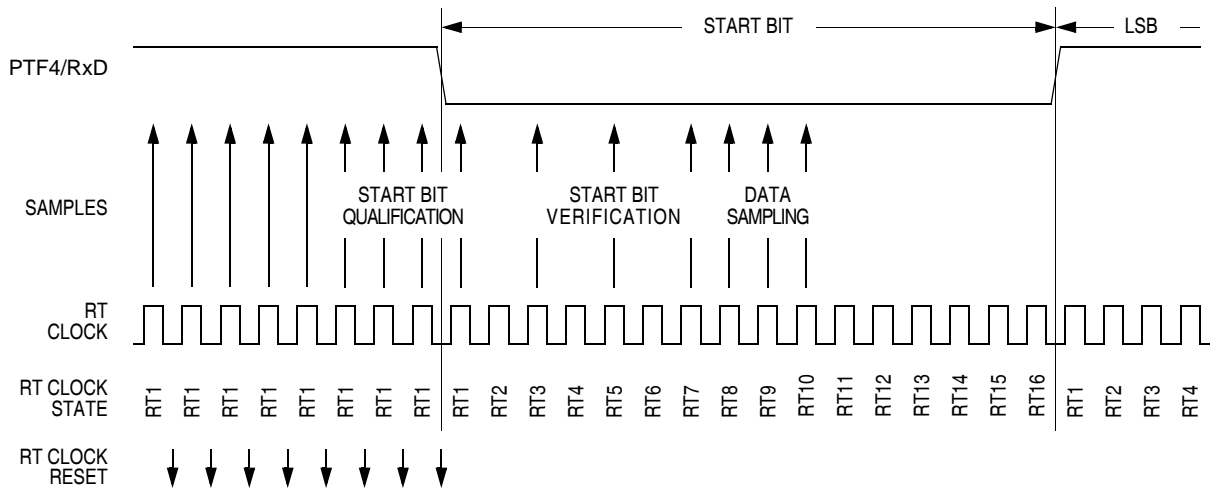
After a complete character shifts into the receive shift register, the data portion of the character transfers to the SCDR. The SCI receiver full bit, SCRF, in SCI status register 1 (SCS1) becomes set, indicating that the received byte can be read. If the SCI receive interrupt enable bit, SCRIE, in SCC2 is also set, the SCRF bit generates a receiver CPU interrupt request.

### 14.4.3.3 Data Sampling

The receiver samples the PTF4/RxD pin at the RT clock rate. The RT clock is an internal signal with a frequency 16 times the baud rate. To adjust for baud rate mismatch, the RT clock is resynchronized at the following times (see [Figure 14-6](#)):

- After every start bit
- After the receiver detects a data bit change from logic 1 to logic 0 (after the majority of data bit samples at RT8, RT9, and RT10 return a valid logic 1 and the majority of the next RT8, RT9, and RT10 samples return a valid logic 0)

To locate the start bit, data recovery logic does an asynchronous search for a logic 0 preceded by three logic 1s. When the falling edge of a possible start bit occurs, the RT clock begins to count to 16.



**Figure 14-6. Receiver Data Sampling**

To verify the start bit and to detect noise, data recovery logic takes samples at RT3, RT5, and RT7. [Table 14-1](#) summarizes the results of the start bit verification samples.

**Table 14-1. Start Bit Verification**

RT3, RT5, and RT7 Samples	Start Bit Verification	Noise Flag
000	Yes	0
001	Yes	1
010	Yes	1
011	No	0
100	Yes	1
101	No	0
110	No	0
111	No	0

If start bit verification is not successful, the RT clock is reset and a new search for a start bit begins.

To determine the value of a data bit and to detect noise, recovery logic takes samples at RT8, RT9, and RT10. [Table 14-2](#) summarizes the results of the data bit samples.

**Table 14-2. Data Bit Recovery**

RT8, RT9, and RT10 Samples	Data Bit Determination	Noise Flag
000	0	0
001	0	1
010	0	1
011	1	1
100	0	1
101	1	1
110	1	1
111	1	0

**NOTE:** *The RT8, RT9, and RT10 samples do not affect start bit verification. If any or all of the RT8, RT9, and RT10 start bit samples are logic 1s following a successful start bit verification, the noise flag (NF) is set and the receiver assumes that the bit is a start bit.*

To verify a stop bit and to detect noise, recovery logic takes samples at RT8, RT9, and RT10. [Table 14-3](#) summarizes the results of the stop bit samples.

**Table 14-3. Stop Bit Recovery**

RT8, RT9, and RT10 Samples	Framing Error Flag	Noise Flag
000	1	0
001	1	1
010	1	1
011	0	1
100	1	1
101	0	1
110	0	1
111	0	0



#### 14.4.3.4 Framing Errors

If the data recovery logic does not detect a logic 1 where the stop bit should be in an incoming character, it sets the framing error bit, FE, in SCS1. The FE flag is set at the same time that the SCRF bit is set. A break character that has no stop bit also sets the FE bit.

#### 14.4.3.5 Receiver Wake-Up

So that the MCU can ignore transmissions intended only for other receivers in multiple-receiver systems, the receiver can be put into a standby state. Setting the receiver wake-up bit, RWU, in SCC2 puts the receiver into a standby state during which receiver interrupts are disabled.

Depending on the state of the WAKE bit in SCC1, either of two conditions on the PTF4/RxD pin can bring the receiver out of the standby state:

- Address mark — An address mark is a logic 1 in the most significant bit position of a received character. When the WAKE bit is set, an address mark wakes the receiver from the standby state by clearing the RWU bit. The address mark also sets the SCI receiver full bit, SCRF. Software can then compare the character containing the address mark to the user-defined address of the receiver. If they are the same, the receiver remains awake and processes the characters that follow. If they are not the same, software can set the RWU bit and put the receiver back into the standby state.
- Idle input line condition — When the WAKE bit is clear, an idle character on the PTF4/RxD pin wakes the receiver from the standby state by clearing the RWU bit. The idle character that wakes the receiver does not set the receiver idle bit, IDLE, or the SCI receiver full bit, SCRF. The idle line type bit, ILTY, determines whether the receiver begins counting logic 1s as idle character bits after the start bit or after the stop bit.

**NOTE:** *Clearing the WAKE bit after the PTF4/RxD pin has been idle can cause the receiver to wake up immediately.*

### 14.4.3.6 Receiver Interrupts

The following sources can generate CPU interrupt requests from the SCI receiver:

- **SCI receiver full (SCRF)** — The SCRF bit in SCS1 indicates that the receive shift register has transferred a character to the SCDR. SCRF can generate a receiver CPU interrupt request. Setting the SCI receive interrupt enable bit, SCRIE, in SCC2 enables the SCRF bit to generate receiver CPU interrupts.
- **Idle input (IDLE)** — The IDLE bit in SCS1 indicates that 10 or 11 consecutive logic 1s shifted in from the PTF4/RxD pin. The idle line interrupt enable bit, ILIE, in SCC2 enables the IDLE bit to generate CPU interrupt requests.

### 14.4.3.7 Error Interrupts

The following receiver error flags in SCS1 can generate CPU interrupt requests:

- **Receiver overrun (OR)** — The OR bit indicates that the receive shift register shifted in a new character before the previous character was read from the SCDR. The previous character remains in the SCDR, and the new character is lost. The overrun interrupt enable bit, ORIE, in SCC3 enables OR to generate SCI error CPU interrupt requests.
- **Noise flag (NF)** — The NF bit is set when the SCI detects noise on incoming data or break characters, including start, data, and stop bits. The noise error interrupt enable bit, NEIE, in SCC3 enables NF to generate SCI error CPU interrupt requests.
- **Framing error (FE)** — The FE bit in SCS1 is set when a logic 0 occurs where the receiver expects a stop bit. The framing error interrupt enable bit, FEIE, in SCC3 enables FE to generate SCI error CPU interrupt requests.
- **Parity error (PE)** — The PE bit in SCS1 is set when the SCI detects a parity error in incoming data. The parity error interrupt enable bit, PEIE, in SCC3 enables PE to generate SCI error CPU interrupt requests.

## 14.5 Wait Mode

The WAIT and STOP instructions put the MCU in low-power-consumption standby modes.

The SCI module remains active after the execution of a WAIT instruction. In wait mode the SCI module registers are not accessible by the CPU. Any enabled CPU interrupt request from the SCI module can bring the MCU out of wait mode.

If SCI module functions are not required during wait mode, reduce power consumption by disabling the module before executing the WAIT instruction.

## 14.6 SCI During Break Module Interrupts

The system integration module (SIM) controls whether status bits in other modules can be cleared during interrupts generated by the break module. The BCFE bit in the SIM break flag control register (SBFCR) enables software to clear status bits during the break state.

To allow software to clear status bits during a break interrupt, write a logic 1 to the BCFE bit. If a status bit is cleared during the break state, it remains cleared when the MCU exits the break state.

To protect status bits during the break state, write a logic 0 to the BCFE bit. With BCFE at logic 0 (its default state), software can read and write I/O registers during the break state without affecting status bits. Some status bits have a two-step read/write clearing procedure. If software does the first step on such a bit before the break, the bit cannot change during the break state as long as BCFE is at logic 0. After the break, doing the second step clears the status bit.

## 14.7 I/O Signals

Port F shares two of its pins with the SCI module. The two SCI I/O pins are:

- PTF5/TxD — Transmit data
- PTF4/RxD — Receive data

### 14.7.1 PTF5/TxD (Transmit Data)

The PTF5/TxD pin is the serial data output from the SCI transmitter. The SCI shares the PTF5/TxD pin with port F. When the SCI is enabled, the PTF5/TxD pin is an output regardless of the state of the DDRF5 bit in data direction register F (DDRF).

### 14.7.2 PTF4/RxD (Receive Data)

The PTF4/RxD pin is the serial data input to the SCI receiver. The SCI shares the PTF4/RxD pin with port F. When the SCI is enabled, the PTF4/RxD pin is an input regardless of the state of the DDRF4 bit in data direction register F (DDRF).

## 14.8 I/O Registers

The following I/O registers control and monitor SCI operation:

- SCI control register 1 (SCC1)
- SCI control register 2 (SCC2)
- SCI control register 3 (SCC3)
- SCI status register 1 (SCS1)
- SCI status register 2 (SCS2)
- SCI data register (SCDR)
- SCI baud rate register (SCBR)

### 14.8.1 SCI Control Register 1

SCI control register 1:

- Enables loop mode operation
- Enables the SCI
- Controls output polarity
- Controls character length
- Controls SCI wake-up method
- Controls idle character detection
- Enables parity function
- Controls parity type

Address: \$0038

	Bit 7	6	5	4	3	2	1	Bit 0
Read:	LOOPS	ENSCI	TXINV	M	WAKE	ILTY	PEN	PTY
Write:								
Reset:	0	0	0	0	0	0	0	0

**Figure 14-7. SCI Control Register 1 (SCC1)**

#### LOOPS — Loop Mode Select Bit

This read/write bit enables loop mode operation. In loop mode the PTE6/RxD pin is disconnected from the SCI, and the transmitter output goes into the receiver input. Both the transmitter and the receiver must be enabled to use loop mode. Reset clears the LOOPS bit.

1 = Loop mode enabled

0 = Normal operation enabled

#### ENSCI — Enable SCI Bit

This read/write bit enables the SCI and the SCI baud rate generator. Clearing ENSCI sets the SCTE and TC bits in SCI status register 1 and disables transmitter interrupts. Reset clears the ENSCI bit.

1 = SCI enabled

0 = SCI disabled

### TXINV — Transmit Inversion Bit

This read/write bit reverses the polarity of transmitted data. Reset clears the TXINV bit.

- 1 = Transmitter output inverted
- 0 = Transmitter output not inverted

**NOTE:** *Setting the TXINV bit inverts all transmitted values, including idle, break, start, and stop bits.*

### M — Mode (Character Length) Bit

This read/write bit determines whether SCI characters are eight or nine bits long. (See [Table 14-4](#).) The ninth bit can serve as an extra stop bit, as a receiver wake-up signal, or as a parity bit. Reset clears the M bit.

- 1 = 9-bit SCI characters
- 0 = 8-bit SCI characters

### WAKE — Wake-Up Condition Bit

This read/write bit determines which condition wakes up the SCI: a logic 1 (address mark) in the most significant bit position of a received character or an idle condition on the PTE6/RxD pin. Reset clears the WAKE bit.

- 1 = Address mark wake-up
- 0 = Idle line wake-up

### ILTY — Idle Line Type Bit

This read/write bit determines when the SCI starts counting logic 1s as idle character bits. The counting begins either after the start bit or after the stop bit. If the count begins after the start bit, then a string of logic 1s preceding the stop bit may cause false recognition of an idle character. Beginning the count after the stop bit avoids false idle character recognition, but requires properly synchronized transmissions. Reset clears the ILTY bit.

- 1 = Idle character bit count begins after stop bit
- 0 = Idle character bit count begins after start bit

**PEN — Parity Enable Bit**

This read/write bit enables the SCI parity function. (See [Table 14-4](#).) When enabled, the parity function inserts a parity bit in the most significant bit position. (See [Figure 14-3](#).) Reset clears the PEN bit.

1 = Parity function enabled

0 = Parity function disabled

**PTY — Parity Bit**

This read/write bit determines whether the SCI generates and checks for odd parity or even parity. (See [Table 14-4](#).) Reset clears the PTY bit.

1 = Odd parity

0 = Even parity

**NOTE:** *Changing the PTY bit in the middle of a transmission or reception can generate a parity error.*

**Table 14-4. Character Format Selection**

Control Bits		Character Format				
M	PEN:PTY	Start Bits	Data Bits	Parity	Stop Bits	Character Length
0	0X	1	8	None	1	10 bits
1	0X	1	9	None	1	11 bits
0	10	1	7	Even	1	10 bits
0	11	1	7	Odd	1	10 bits
1	10	1	8	Even	1	11 bits
1	11	1	8	Odd	1	11 bits

## 14.8.2 SCI Control Register 2

SCI control register 2:

- Enables the following CPU interrupt requests:
  - Enables the SCTE bit to generate transmitter CPU interrupt requests
  - Enables the TC bit to generate transmitter CPU interrupt requests
  - Enables the SCRF bit to generate receiver CPU interrupt requests
  - Enables the IDLE bit to generate receiver CPU interrupt requests
- Enables the transmitter
- Enables the receiver
- Enables SCI wake-up
- Transmits SCI break characters

Address: \$0039

	Bit 7	6	5	4	3	2	1	Bit 0
Read:	SCTIE	TCIE	SCRIE	ILIE	TE	RE	RWU	SBK
Write:								
Reset:	0	0	0	0	0	0	0	0

**Figure 14-8. SCI Control Register 2 (SCC2)**

**SCTIE** — SCI Transmit Interrupt Enable Bit

This read/write bit enables the SCTE bit to generate SCI transmitter CPU interrupt requests. Setting the SCTIE bit in SCC3 enables SCTE CPU interrupt requests. Reset clears the SCTIE bit.

1 = SCTE enabled to generate CPU interrupt

0 = SCTE not enabled to generate CPU interrupt



**TCIE — Transmission Complete Interrupt Enable Bit**

This read/write bit enables the TC bit to generate SCI transmitter CPU interrupt requests. Reset clears the TCIE bit.

1 = TC enabled to generate CPU interrupt requests

0 = TC not enabled to generate CPU interrupt requests

**SCRIE — SCI Receive Interrupt Enable Bit**

This read/write bit enables the SCRF bit to generate SCI receiver CPU interrupt requests. Setting the SCRIE bit in SCC3 enables the SCRF bit to generate CPU interrupt requests. Reset clears the SCRIE bit.

1 = SCRF enabled to generate CPU interrupt

0 = SCRF not enabled to generate CPU interrupt

**ILIE — Idle Line Interrupt Enable Bit**

This read/write bit enables the IDLE bit to generate SCI receiver CPU interrupt requests. Reset clears the ILIE bit.

1 = IDLE enabled to generate CPU interrupt requests

0 = IDLE not enabled to generate CPU interrupt requests

**TE — Transmitter Enable Bit**

Setting this read/write bit begins the transmission by sending a preamble of ten or eleven logic 1s from the transmit shift register to the PTF5/TxD pin. If software clears the TE bit, the transmitter completes any transmission in progress before the PTF5/TxD returns to the idle condition (logic 1). Clearing and then setting TE during a transmission queues an idle character to be sent after the character currently being transmitted. Reset clears the TE bit.

1 = Transmitter enabled

0 = Transmitter disabled

**NOTE:** *Writing to the TE bit is not allowed when the enable SCI bit (ENSCI) is clear. ENSCI is in SCI control register 1.*

### RE — Receiver Enable Bit

Setting this read/write bit enables the receiver. Clearing the RE bit disables the receiver but does not affect receiver interrupt flag bits.

Reset clears the RE bit.

1 = Receiver enabled

0 = Receiver disabled

**NOTE:** *Writing to the RE bit is not allowed when the enable SCI bit (ENSCI) is clear. ENSCI is in SCI control register 1.*

### RWU — Receiver Wake-Up Bit

This read/write bit puts the receiver in a standby state during which receiver interrupts are disabled. The WAKE bit in SCC1 determines whether an idle input or an address mark brings the receiver out of the standby state and clears the RWU bit. Reset clears the RWU bit.

1 = Standby state

0 = Normal operation

### SBK — Send Break Bit

Setting and then clearing this read/write bit transmits a break character followed by a logic 1. The logic 1 after the break character guarantees recognition of a valid start bit. If SBK remains set, the transmitter continuously transmits break characters with no logic 1s between them. Reset clears the SBK bit.

1 = Transmit break characters

0 = No break characters being transmitted

**NOTE:** *Do not toggle the SBK bit immediately after setting the SCTE bit. Toggling SBK too early causes the SCI to send a break character instead of a preamble.*

### 14.8.3 SCI Control Register 3

SCI control register 3:

- Stores the ninth SCI data bit received and the ninth SCI data bit to be transmitted
- Enables SCI receiver full (SCRF)
- Enables SCI transmitter empty (SCTE)
- Enables the following interrupts:
  - Receiver overrun interrupts
  - Noise error interrupts
  - Framing error interrupts
  - Parity error interrupts

Address: \$003A

	Bit 7	6	5	4	3	2	1	Bit 0
Read:	R8	T8	0	0	ORIE	NEIE	FEIE	PEIE
Write:								
Reset:	U	U	0	0	0	0	0	0

= Unimplemented
 U = Unaffected

**Figure 14-9. SCI Control Register 3 (SCC3)**

#### R8 — Received Bit 8

When the SCI is receiving 9-bit characters, R8 is the read-only ninth bit (bit 8) of the received character. R8 is received at the same time that the SCDR receives the other 8 bits.

When the SCI is receiving 8-bit characters, R8 is a copy of the eighth bit (bit 7). Reset has no effect on the R8 bit.

#### T8 — Transmitted Bit 8

When the SCI is transmitting 9-bit characters, T8 is the read/write ninth bit (bit 8) of the transmitted character. T8 is loaded into the transmit shift register at the same time that the SCDR is loaded into the transmit shift register. Reset has no effect on the T8 bit.

### ORIE — Receiver Overrun Interrupt Enable Bit

This read/write bit enables SCI error CPU interrupt requests generated by the receiver overrun bit, OR.

- 1 = SCI error CPU interrupt requests from OR bit enabled
- 0 = SCI error CPU interrupt requests from OR bit disabled

### NEIE — Receiver Noise Error Interrupt Enable Bit

This read/write bit enables SCI error CPU interrupt requests generated by the noise error bit, NE. Reset clears NEIE.

- 1 = SCI error CPU interrupt requests from NE bit enabled
- 0 = SCI error CPU interrupt requests from NE bit disabled

### FEIE — Receiver Framing Error Interrupt Enable Bit

This read/write bit enables SCI error CPU interrupt requests generated by the framing error bit, FE. Reset clears FEIE.

- 1 = SCI error CPU interrupt requests from FE bit enabled
- 0 = SCI error CPU interrupt requests from FE bit disabled

### PEIE — Receiver Parity Error Interrupt Enable Bit

This read/write bit enables SCI receiver CPU interrupt requests generated by the parity error bit, PE. (See [14.8.4 SCI Status Register 1](#).) Reset clears PEIE.

- 1 = SCI error CPU interrupt requests from PE bit enabled
- 0 = SCI error CPU interrupt requests from PE bit disabled


### 14.8.4 SCI Status Register 1

SCI status register 1 contains flags to signal these conditions:

- Transfer of SCDR data to transmit shift register complete
- Transmission complete
- Transfer of receive shift register data to SCDR complete
- Receiver input idle
- Receiver overrun
- Noisy data
- Framing error
- Parity error

Address: \$003B

	Bit 7	6	5	4	3	2	1	Bit 0
Read:	SCTE	TC	SCRF	IDLE	OR	NF	FE	PE
Write:								
Reset:	1	1	0	0	0	0	0	0

 = Unimplemented

**Figure 14-10. SCI Status Register 1 (SCS1)**

#### SCTE — SCI Transmitter Empty Bit

This clearable, read-only bit is set when the SCDR transfers a character to the transmit shift register. SCTE can generate an SCI transmitter CPU interrupt request. When the SCTIE bit in SCC2 is set, SCTE generates an SCI transmitter CPU interrupt request. In normal operation, clear the SCTE bit by reading SCS1 with SCTE set and then writing to SCDR. Reset sets the SCTE bit.

1 = SCDR data transferred to transmit shift register

0 = SCDR data not transferred to transmit shift register

### TC — Transmission Complete Bit

This read-only bit is set when the SCTE bit is set, and no data, preamble, or break character is being transmitted. TC generates an SCI transmitter CPU interrupt request if the TCIE bit in SCC2 is also set. TC is automatically cleared when data, preamble or break is queued and ready to be sent. There may be up to 1.5 transmitter clocks of latency between queueing data, preamble, and break and the transmission actually starting. Reset sets the TC bit.

1 = No transmission in progress

0 = Transmission in progress

### SCRF — SCI Receiver Full Bit

This clearable, read-only bit is set when the data in the receive shift register transfers to the SCI data register. SCRF can generate an SCI receiver CPU interrupt request. When the SCRIE bit in SCC2 is set, SCRF generates a CPU interrupt request. In normal operation, clear the SCRF bit by reading SCS1 with SCRF set and then reading the SCDR. Reset clears SCRF.

1 = Received data available in SCDR

0 = Data not available in SCDR

### IDLE — Receiver Idle Bit

This clearable, read-only bit is set when ten or eleven consecutive logic 1s appear on the receiver input. IDLE generates an SCI error CPU interrupt request if the ILIE bit in SCC2 is also set. Clear the IDLE bit by reading SCS1 with IDLE set and then reading the SCDR. After the receiver is enabled, it must receive a valid character that sets the SCRF bit before an idle condition can set the IDLE bit. Also, after the IDLE bit has been cleared, a valid character must again set the SCRF bit before an idle condition can set the IDLE bit. Reset clears the IDLE bit.

1 = Receiver input idle

0 = Receiver input active (or idle since the IDLE bit was cleared)

**OR — Receiver Overrun Bit**

This clearable, read-only bit is set when software fails to read the SCDR before the receive shift register receives the next character. The OR bit generates an SCI error CPU interrupt request if the ORIE bit in SCC3 is also set. The data in the shift register is lost, but the data already in the SCDR is not affected. Clear the OR bit by reading SCS1 with OR set and then reading the SCDR. Reset clears the OR bit.

1 = Receive shift register full and SCRF = 1

0 = No receiver overrun

Software latency may allow an overrun to occur between reads of SCS1 and SCDR in the flag-clearing sequence. **Figure 14-11** shows the normal flag-clearing sequence and an example of an overrun caused by a delayed flag-clearing sequence. The delayed read of SCDR does not clear the OR bit because OR was not set when SCS1 was read. Byte 2 caused the overrun and is lost. The next flag-clearing sequence reads byte 3 in the SCDR instead of byte 2.

In applications that are subject to software latency or in which it is important to know which byte is lost due to an overrun, the flag-clearing routine can check the OR bit in a second read of SCS1 after reading the data register.

**NF — Receiver Noise Flag Bit**

This clearable, read-only bit is set when the SCI detects noise on the PTF4/RxD pin. NF generates an NF CPU interrupt request if the NEIE bit in SCC3 is also set. Clear the NF bit by reading SCS1 and then reading the SCDR. Reset clears the NF bit.

1 = Noise detected

0 = No noise detected

**FE — Receiver Framing Error Bit**

This clearable, read-only bit is set when a logic 0 is accepted as the stop bit. FE generates an SCI error CPU interrupt request if the FEIE bit in SCC3 also is set. Clear the FE bit by reading SCS1 with FE set and then reading the SCDR. Reset clears the FE bit.

1 = Framing error detected

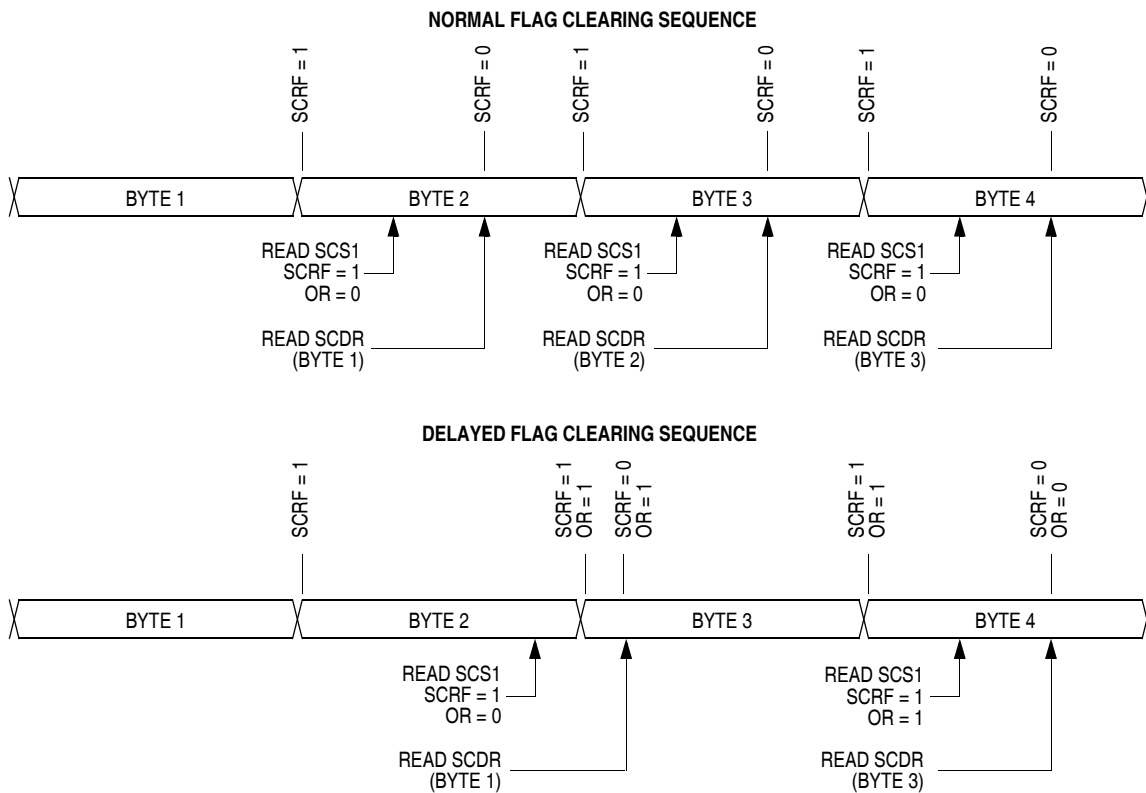
0 = No framing error detected

# Serial Communications Interface Module (SCI)

## PE — Receiver Parity Error Bit

This clearable, read-only bit is set when the SCI detects a parity error in incoming data. PE generates a PE CPU interrupt request if the PEIE bit in SCC3 is also set. Clear the PE bit by reading SCS1 with PE set and then reading the SCDR. Reset clears the PE bit.

- 1 = Parity error detected
- 0 = No parity error detected



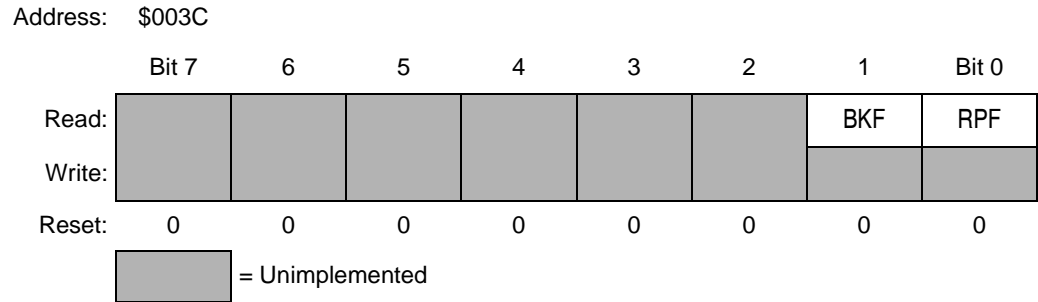
**Figure 14-11. Flag Clearing Sequence**



### 14.8.5 SCI Status Register 2

SCI status register 2 contains flags to signal these conditions:

- Break character detected
- Incoming data



**Figure 14-12. SCI Status Register 2 (SCS2)**

#### BKF — Break Flag Bit

This clearable, read-only bit is set when the SCI detects a break character on the PTF4/RxD pin. In SCS1, the FE and SCRF bits are also set. In 9-bit character transmissions, the R8 bit in SCC3 is cleared. BKF does not generate a CPU interrupt request. Clear BKF by reading SCS2 with BKF set and then reading the SCDR. Once cleared, BKF can become set again only after logic 1s again appear on the PTF4/RxD pin followed by another break character. Reset clears the BKF bit.

- 1 = Break character detected
- 0 = No break character detected

#### RPF — Reception in Progress Flag Bit

This read-only bit is set when the receiver detects a logic 0 during the RT1 time period of the start bit search. RPF does not generate an interrupt request. RPF is reset after the receiver detects false start bits (usually from noise or a baud rate mismatch, or when the receiver detects an idle character. Polling RPF before disabling the SCI module or entering stop mode can show whether a reception is in progress.

- 1 = Reception in progress
- 0 = No reception in progress

# Serial Communications Interface Module (SCI)

## 14.8.6 SCI Data Register

The SCI data register is the buffer between the internal data bus and the receive and transmit shift registers. Reset has no effect on data in the SCI data register.

Address: \$003D

	Bit 7	6	5	4	3	2	1	Bit 0
Read:	R7	R6	R5	R4	R3	R2	R1	R0
Write:	T7	T6	T5	T4	T3	T2	T1	T0
Reset:	Unaffected by reset							

**Figure 14-13. SCI Data Register (SCDR)**

### R7/T7:R0/T0 — Receive/Transmit Data Bits

Reading address \$003D accesses the read-only received data bits, R7:R0. Writing to address \$003D writes the data to be transmitted, T7:T0. Reset has no effect on the SCI data register.

## 14.8.7 SCI Baud Rate Register

The baud rate register selects the baud rate for both the receiver and the transmitter.

Address: \$003E

	Bit 7	6	5	4	3	2	1	Bit 0
Read:			SCP1	SCP0	R	SCR2	SCR1	SCR0
Write:								
Reset:	0	0	0	0	0	0	0	0

= Unimplemented
 R = Reserved for Factory Test

**Figure 14-14. SCI Baud Rate Register (SCBR)**

### SCP1 and SCP0 — SCI Baud Rate Prescaler Bits

These read/write bits select the baud rate prescaler divisor as shown in [Table 14-5](#). Reset clears SCP1 and SCP0.

**Table 14-5. SCI Baud Rate Prescaling**

SCP1:SCP0	Prescaler Divisor (PD)
00	1
01	3
10	4
11	13

**SCR2–SCR0 — SCI Baud Rate Select Bits**

These read/write bits select the SCI baud rate divisor as shown in [Table 14-6](#). Reset clears SCR2–SCR0.

**Table 14-6. SCI Baud Rate Selection**

SCR2:SCR1:SCR0	Baud Rate Divisor (BD)
000	1
001	2
010	4
011	8
100	16
101	32
110	64
111	128

Use this formula to calculate the SCI baud rate:

$$\text{Baud rate} = \frac{f_{\text{Bus}}}{64 \times \text{PD} \times \text{BD}}$$

where:

$f_{\text{Bus}}$  = bus frequency

PD = prescaler divisor

BD = baud rate divisor

[Table 14-7](#) shows the SCI baud rates that can be generated with a 4.9152-MHz crystal.

# Serial Communications Interface Module (SCI)

**Table 14-7. SCI Baud Rate Selection Examples**

SCP1:SCP0	Prescaler Divisor (PD)	SCR2:SCR1:SCR0	Baud Rate Divisor (BD)	Baud Rate (f <sub>BUS</sub> = 4.9152 MHz)
00	1	000	1	76,800
00	1	001	2	38,400
00	1	010	4	19,200
00	1	011	8	9600
00	1	100	16	4800
00	1	101	32	2400
00	1	110	64	1200
00	1	111	128	600
01	3	000	1	25,600
01	3	001	2	12,800
01	3	010	4	6400
01	3	011	8	3200
01	3	100	16	1600
01	3	101	32	800
01	3	110	64	400
01	3	111	128	200
10	4	000	1	19,200
10	4	001	2	9600
10	4	010	4	4800
10	4	011	8	2400
10	4	100	16	1200
10	4	101	32	600
10	4	110	64	300
10	4	111	128	150
11	13	000	1	5908
11	13	001	2	2954
11	13	010	4	1478
11	13	011	8	738
11	13	100	16	370
11	13	101	32	184
11	13	110	64	92
11	13	111	128	46

## Section 15. Input/Output (I/O) Ports

### 15.1 Contents

15.2	Introduction .....	318
15.3	Port A .....	320
15.3.1	Port A Data Register .....	320
15.3.2	Data Direction Register A .....	320
15.4	Port B .....	322
15.4.1	Port B Data Register .....	322
15.4.2	Data Direction Register B .....	322
15.5	Port C .....	324
15.5.1	Port C Data Register .....	324
15.5.2	Data Direction Register C .....	325
15.6	Port D .....	326
15.7	Port E .....	328
15.7.1	Port E Data Register .....	328
15.7.2	Data Direction Register E .....	329
15.8	Port F .....	330
15.8.1	Port F Data Register .....	330
15.8.2	Data Direction Register F .....	331

## 15.2 Introduction

Thirty-seven bidirectional input-output (I/O) pins and seven input pins form eight parallel ports. All I/O pins are programmable as inputs or outputs.

**NOTE:** Connect any unused I/O pins to an appropriate logic level, either  $V_{DD}$  or  $V_{SS}$ . Although the I/O ports do not require termination for proper operation, termination reduces excess current consumption and the possibility of electrostatic damage.

Addr.	Name	Bit 7	6	5	4	3	2	1	Bit 0	
\$0000	Port A Data Register (PTA)	Read:	PTA7	PTA6	PTA5	PTA4	PTA3	PTA2	PTA1	PTA0
		Write:								
		Reset:	Unaffected by reset							
\$0001	Port B Data Register (PTB)	Read:	PTB7	PTB6	PTB5	PTB4	PTB3	PTB2	PTB1	PTB0
		Write:								
		Reset:	Unaffected by reset							
\$0002	Port C Data Register (PTC)	Read:	0	PTC6	PTC5	PTC4	PTC3	PTC2	PTC1	PTC0
		Write:								
		Reset:	Unaffected by reset							
\$0003	Port D Data Register (PTD)	Read:	0	PTD6	PTD5	PTD4	PTD3	PTD2	PTD1	PTD0
		Write:								
		Reset:	Unaffected by reset							
\$0004	Port E Data Register (PTE)	Read:	PTE7	PTE6	PTE5	PTE4	PTE3	PTE2	PTE1	PTE0
		Write:								
		Reset:	Unaffected by reset							
\$0005	Port F Data Register (PTF)	Read:	0	0	PTF5	PTF4	PTF3	PTF2	PTF1	PTF0
		Write:								
		Reset:	Unaffected by reset							
				= Unimplemented						

**Figure 15-1. I/O Port Register Summary**

Addr.	Name	Bit 7	6	5	4	3	2	1	Bit 0	
\$0006	Data Direction Register A (DDRA)	Read:	DDRA7	DDRA6	DDRA5	DDRA4	DDRA3	DDRA2	DDRA1	DDRA0
		Write:								
		Reset:	0	0	0	0	0	0	0	0
\$0007	Data Direction Register B (DDRB)	Read:	DDRB7	DDRB6	DDRB5	DDRB4	DDRB3	DDRB2	DDRB1	DDRB0
		Write:								
		Reset:	0	0	0	0	0	0	0	0
\$0008	Data Direction Register C (DDRC)	Read:	0	DDRC6	DDRC5	DDRC4	DDRC3	DDRC2	DDRC1	DDRC0
		Write:								
		Reset:	0	0	0	0	0	0	0	0
\$000A	Data Direction Register E (DDRE)	Read:	DDRE7	DDRE6	DDRE5	DDRE4	DDRE3	DDRE2	DDRE1	DDRE0
		Write:								
		Reset:	0	0	0	0	0	0	0	0
\$000B	Data Direction Register F (DDRF)	Read:	0	0	DDRF5	DDRF4	DDRF3	DDRF2	DDRF1	DDRF0
		Write:								
		Reset:	0	0	0	0	0	0	0	0

= Unimplemented

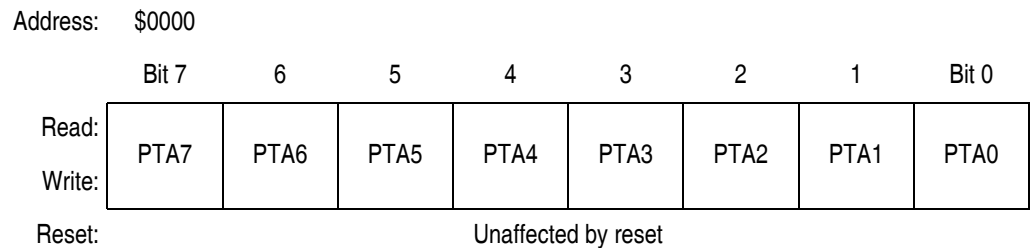
**Figure 15-1. I/O Port Register Summary (Continued)**

## 15.3 Port A

Port A is an 8-bit general-purpose bidirectional I/O port.

### 15.3.1 Port A Data Register

The port A data register (PTA) contains a data latch for each of the eight port A pins.



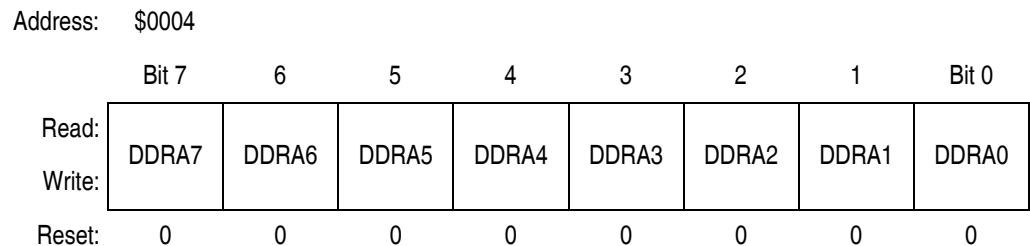
**Figure 15-2. Port A Data Register (PTA)**

PTA[7:0] — Port A Data Bits

These read/write bits are software programmable. Data direction of each port A pin is under the control of the corresponding bit in data direction register A. Reset has no effect on port A data.

### 15.3.2 Data Direction Register A

Data direction register A (DDRA) determines whether each port A pin is an input or an output. Writing a logic 1 to a DDRA bit enables the output buffer for the corresponding port A pin; a logic 0 disables the output buffer.



**Figure 15-3. Data Direction Register A (DDRA)**



### DDRA[7:0] — Data Direction Register A Bits

These read/write bits control port A data direction. Reset clears DDRA[7:0], configuring all port A pins as inputs.

1 = Corresponding port A pin configured as output

0 = Corresponding port A pin configured as input

**NOTE:** Avoid glitches on port A pins by writing to the port A data register before changing data direction register A bits from 0 to 1.

Figure 15-4 shows the port A I/O logic.

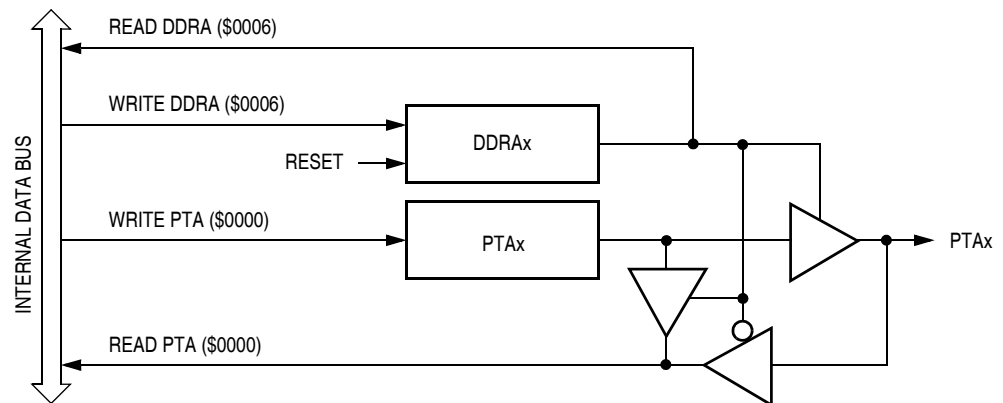


Figure 15-4. Port A I/O Circuit

When bit DDRA<sub>x</sub> is a logic 1, reading address \$0000 reads the PTA<sub>x</sub> data latch. When bit DDRA<sub>x</sub> is a logic 0, reading address \$0000 reads the voltage level on the pin. The data latch can always be written, regardless of the state of its data direction bit. Table 15-1 summarizes the operation of the port A pins.

Table 15-1. Port A Pin Functions

DDRA Bit	PTA Bit	I/O Pin Mode	Accesses to DDRA	Accesses to PTA	
			Read/Write	Read	Write
0	X <sup>(1)</sup>	Input, Hi-Z <sup>(2)</sup>	DDRA[7:0]	Pin	PTA[7:0] <sup>(3)</sup>
1	X	Output	DDRA[7:0]	PTA[7:0]	PTA[7:0]

1. X = don't care

2. Hi-Z = high impedance

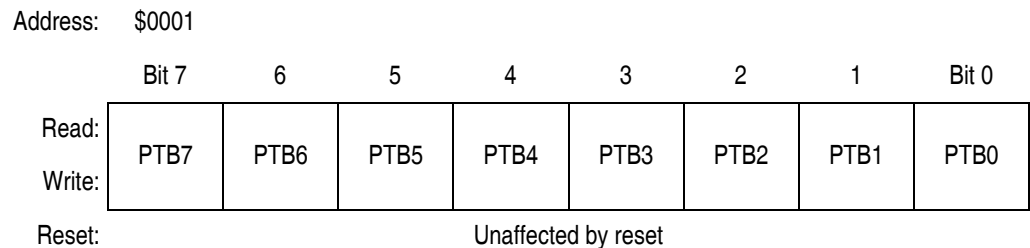
3. Writing affects data register, but does not affect input.

## 15.4 Port B

Port B is an 8-bit general-purpose bidirectional I/O port that shares its pins with the analog-to-digital convertor module (ADC).

### 15.4.1 Port B Data Register

The port B data register (PTB) contains a data latch for each of the eight port B pins.



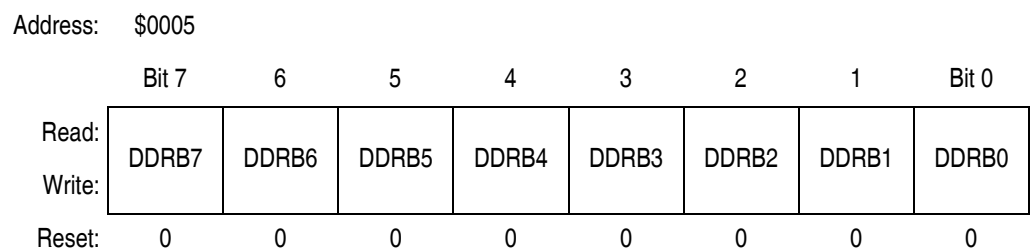
**Figure 15-5. Port B Data Register (PTB)**

#### PTB[7:0] — Port B Data Bits

These read/write bits are software-programmable. Data direction of each port B pin is under the control of the corresponding bit in data direction register B. Reset has no effect on port B data.

### 15.4.2 Data Direction Register B

Data direction register B (DDRB) determines whether each port B pin is an input or an output. Writing a logic 1 to a DDRB bit enables the output buffer for the corresponding port B pin; a logic 0 disables the output buffer.



**Figure 15-6. Data Direction Register B (DDRB)**

### DDRB[7:0] — Data Direction Register B Bits

These read/write bits control port B data direction. Reset clears DDRB[7:0], configuring all port B pins as inputs.

1 = Corresponding port B pin configured as output

0 = Corresponding port B pin configured as input

**NOTE:** Avoid glitches on port B pins by writing to the port B data register before changing data direction register B bits from 0 to 1.

Figure 15-7 shows the port B I/O logic.

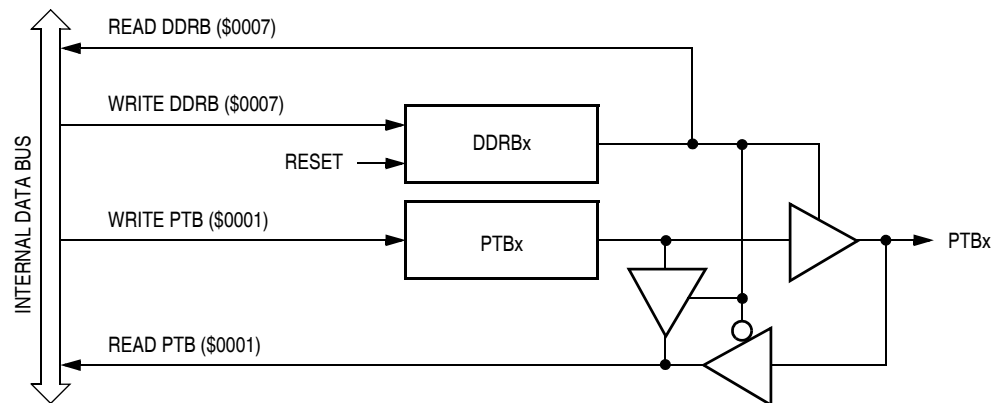


Figure 15-7. Port B I/O Circuit

When bit DDRBx is a logic 1, reading address \$0001 reads the PTBx data latch. When bit DDRBx is a logic 0, reading address \$0001 reads the voltage level on the pin. The data latch can always be written, regardless of the state of its data direction bit. Table 15-2 summarizes the operation of the port B pins.

Table 15-2. Port B Pin Functions

DDRB Bit	PTB Bit	I/O Pin Mode	Accesses to DDRB	Accesses to PTB	
			Read/Write	Read	Write
0	X <sup>(1)</sup>	Input, Hi-Z <sup>(2)</sup>	DDRB[7:0]	Pin	PTB[7:0] <sup>(3)</sup>
1	X	Output	DDRB[7:0]	PTB[7:0]	PTB[7:0]

1. X = don't care

2. Hi-Z = high impedance

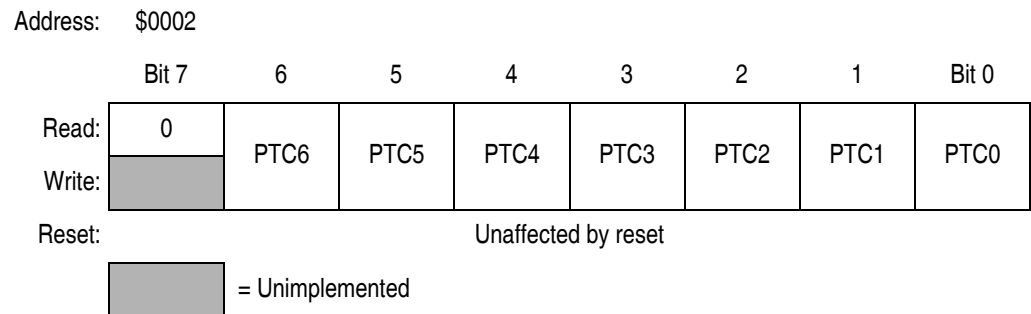
3. Writing affects data register, but does not affect input.

## 15.5 Port C

Port C is a 7-bit general-purpose bidirectional I/O port that shares two of its pins with the analog-to-digital convertor module (ADC).

### 15.5.1 Port C Data Register

The port C data register (PTC) contains a data latch for each of the seven port C pins.



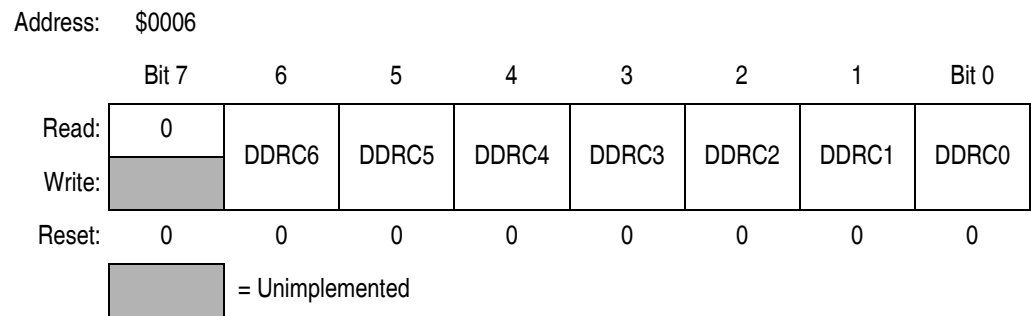
**Figure 15-8. Port C Data Register (PTC)**

#### PTC[6:0] — Port C Data Bits

These read/write bits are software-programmable. Data direction of each port C pin is under the control of the corresponding bit in data direction register C. Reset has no effect on port C data.

## 15.5.2 Data Direction Register C

Data direction register C (DDRC) determines whether each port C pin is an input or an output. Writing a logic 1 to a DDRC bit enables the output buffer for the corresponding port C pin; a logic 0 disables the output buffer.



**Figure 15-9. Data Direction Register C (DDRC)**

### DDRC[6:0] — Data Direction Register C Bits

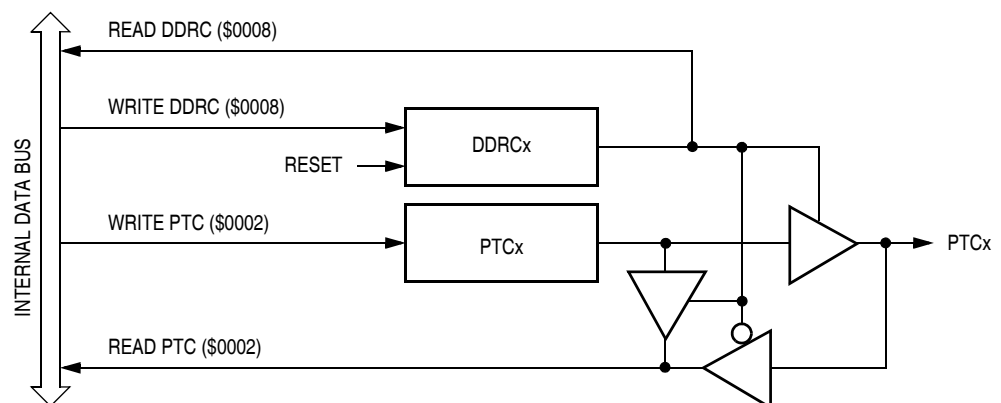
These read/write bits control port C data direction. Reset clears DDRC[6:0], configuring all port C pins as inputs.

1 = Corresponding port C pin configured as output

0 = Corresponding port C pin configured as input

**NOTE:** Avoid glitches on port C pins by writing to the port C data register before changing data direction register C bits from 0 to 1.

**Figure 15-10** shows the port C I/O logic.



**Figure 15-10. Port C I/O Circuit**

When bit DDRCx is a logic 1, reading address \$0002 reads the PTCx data latch. When bit DDRCx is a logic 0, reading address \$0002 reads the voltage level on the pin. The data latch can always be written, regardless of the state of its data direction bit. **Table 15-3** summarizes the operation of the port C pins.

**Table 15-3. Port C Pin Functions**

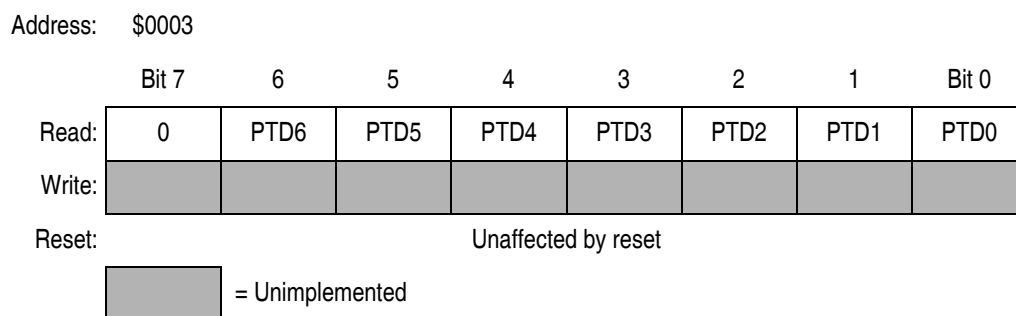
DDRC Bit	PTC Bit	I/O Pin Mode	Accesses to DDRC	Accesses to PTC	
			Read/Write	Read	Write
0	X <sup>(1)</sup>	Input, Hi-Z <sup>(2)</sup>	DDRC[6:0]	Pin	PTC[6:0] <sup>(3)</sup>
1	X	Output	DDRC[6:0]	PTC[6:0]	PTC[6:0]

1. X = don't care
2. Hi-Z = high impedance
3. Writing affects data register, but does not affect input.

## 15.6 Port D

Port D is a 7-bit input only port that shares its pins with the pulse width modulator for motor control module (PWMMC).

The port D data register (PTD) contains a data latch for each of the seven port pins.



**Figure 15-11. Port D Data Register (PTD)**

### PTD[6:0] — Port D Data Bits

These read/write bits are software programmable. Reset has no effect on port D data.

**Figure 15-12** shows the port D input logic.



**Figure 15-12. Port D Input Circuit**

Reading address \$0003 reads the voltage level on the pin. **Table 15-1** summarizes the operation of the port D pins.

**Table 15-4. Port D Pin Functions**

PTD Bit	Pin Mode	Accesses to PTD	
		Read	Write
X <sup>(1)</sup>	Input, Hi-Z <sup>(2)</sup>	Pin	PTD[6:0] <sup>(3)</sup>

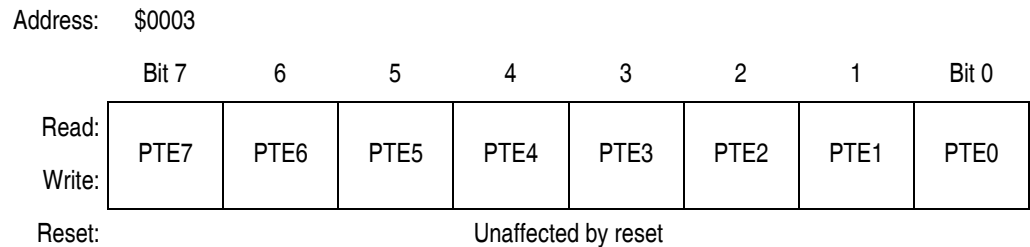
1. X = don't care
2. Hi-Z = high impedance
3. Writing affects data register, but does not affect input.

## 15.7 Port E

Port E is an 8-bit special function port that shares three of its pins with the timer A interface module (TIMA) and five of its pins with the timer B interface module (TIMB).

### 15.7.1 Port E Data Register

The port E data register (PTE) contains a data latch for each of the eight port E pins.



**Figure 15-13. Port E Data Register (PTE)**

#### PTE[7:0] — Port E Data Bits

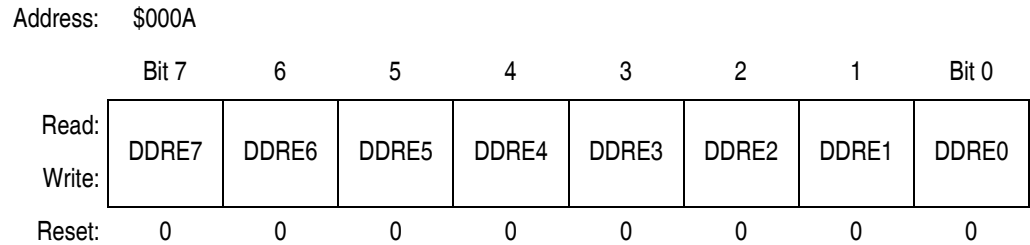
PTE[7:0] are read/write, software-programmable bits. Data direction of each port E pin is under the control of the corresponding bit in data direction register E.

**NOTE:** *Data direction register E (DDRE) does not affect the data direction of port E pins that are being used by the TIMA or TIMB. However, the DDRE bits always determine whether reading port E returns the states of the latches or the states of the pins.*



## 15.7.2 Data Direction Register E

Data direction register E (DDRE) determines whether each port E pin is an input or an output. Writing a logic 1 to a DDRE bit enables the output buffer for the corresponding port E pin; a logic 0 disables the output buffer.



**Figure 15-14. Data Direction Register E (DDRE)**

### DDRE[7:0] — Data Direction Register E Bits

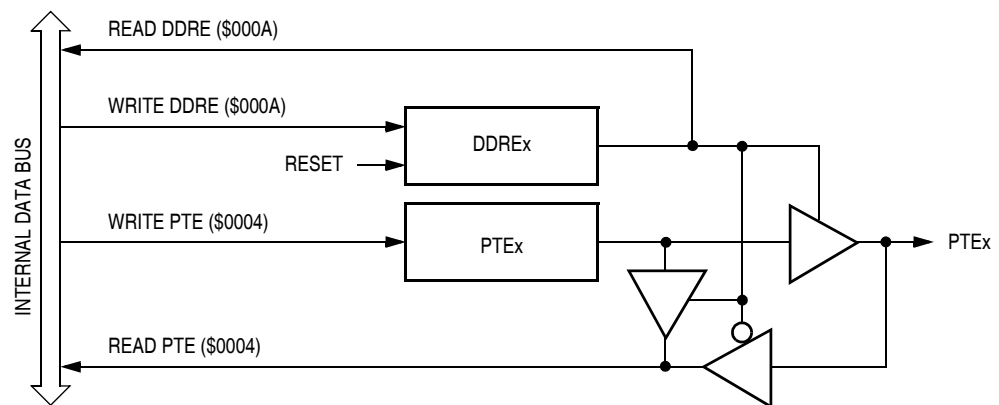
These read/write bits control port E data direction. Reset clears DDRE[7:0], configuring all port E pins as inputs.

1 = Corresponding port E pin configured as output

0 = Corresponding port E pin configured as input

**NOTE:** *Avoid glitches on port E pins by writing to the port E data register before changing data direction register E bits from 0 to 1.*

**Figure 15-15** shows the port E I/O logic.



**Figure 15-15. Port E I/O Circuit**

When bit DDRE<sub>x</sub> is a logic 1, reading address \$0004 reads the PTE<sub>x</sub> data latch. When bit DDRE<sub>x</sub> is a logic 0, reading address \$0004 reads the voltage level on the pin. The data latch can always be written, regardless of the state of its data direction bit. [Table 15-3](#) summarizes the operation of the port E pins.

**Table 15-5. Port E Pin Functions**

DDRE Bit	PTE Bit	I/O Pin Mode	Accesses to DDRE	Accesses to PTE	
			Read/Write	Read	Write
0	X <sup>(1)</sup>	Input, Hi-Z <sup>(2)</sup>	DDRE[7:0]	Pin	PTE[7:0] <sup>(3)</sup>
1	X	Output	DDRE[7:0]	PTE[7:0]	PTE[7:0]

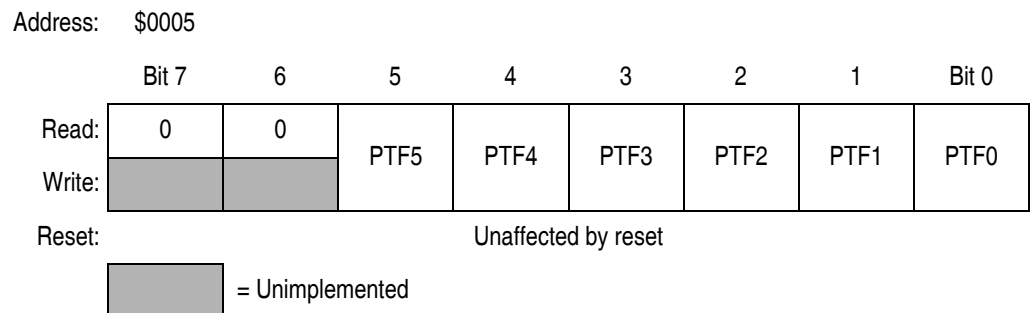
1. X = don't care
2. Hi-Z = high impedance
3. Writing affects data register, but does not affect input.

## 15.8 Port F

Port F is a 6-bit special function port that shares four of its pins with the serial peripheral interface module (SPI) and two pins with the serial communications interface (SCI).

### 15.8.1 Port F Data Register

The port F data register (PTF) contains a data latch for each of the six port F pins.



**Figure 15-16. Port F Data Register (PTF)**

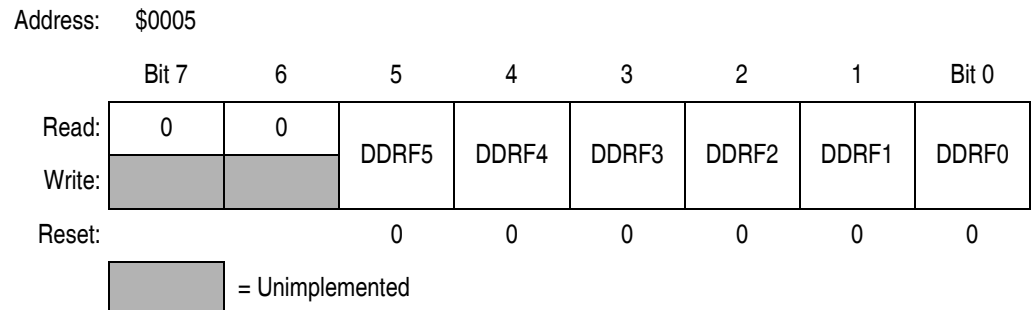
## PTF[5:0] — Port F Data Bits

These read/write bits are software programmable. Data direction of each port F pin is under the control of the corresponding bit in data direction register F. Reset has no effect on PTF[5:0].

**NOTE:** *Data direction register F (DDRF) does not affect the data direction of port F pins that are being used by the SPI or SCI module. However, the DDRF bits always determine whether reading port F returns the states of the latches or the states of the pins.*

## 15.8.2 Data Direction Register F

Data direction register F (DDRF) determines whether each port F pin is an input or an output. Writing a logic 1 to a DDRF bit enables the output buffer for the corresponding port F pin; a logic 0 disables the output buffer.



**Figure 15-17. Data Direct Register F (DDRF)**

## DDRF[5:0] — Data Direction Register F Bits

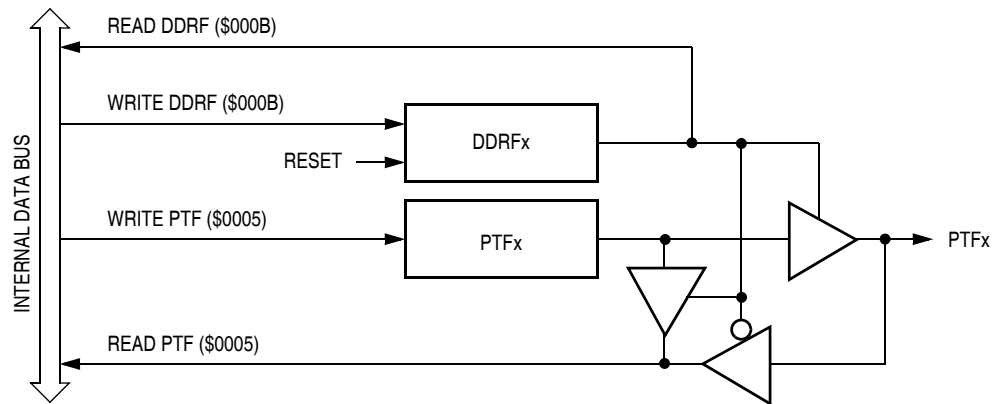
These read/write bits control port F data direction. Reset clears DDRF[5:0], configuring all port F pins as inputs.

1 = Corresponding port F pin configured as output

0 = Corresponding port F pin configured as input

**NOTE:** *Avoid glitches on port F pins by writing to the port F data register before changing data direction register F bits from 0 to 1.*

**Figure 15-18** shows the port F I/O logic.



**Figure 15-18. Port F I/O Circuit**

When bit DDRFx is a logic 1, reading address \$0005 reads the PTFx data latch. When bit DDRFx is a logic 0, reading address \$0005 reads the voltage level on the pin. The data latch can always be written, regardless of the state of its data direction bit. [Table 15-3](#) summarizes the operation of the port F pins.

**Table 15-6. Port F Pin Functions**

DDRF Bit	PTF Bit	I/O Pin Mode	Accesses to DDRF	Accesses to PTF	
			Read/Write	Read	Write
0	X <sup>(1)</sup>	Input, Hi-Z <sup>(2)</sup>	DDRF[6:0]	Pin	PTF[6:0] <sup>(3)</sup>
1	X	Output	DDRF[6:0]	PTF[6:0]	PTF[6:0]

1. X = don't care

2. Hi-Z = high impedance

3. Writing affects data register, but does not affect input.

## Section 16. Computer Operating Properly (COP)

### 16.1 Contents

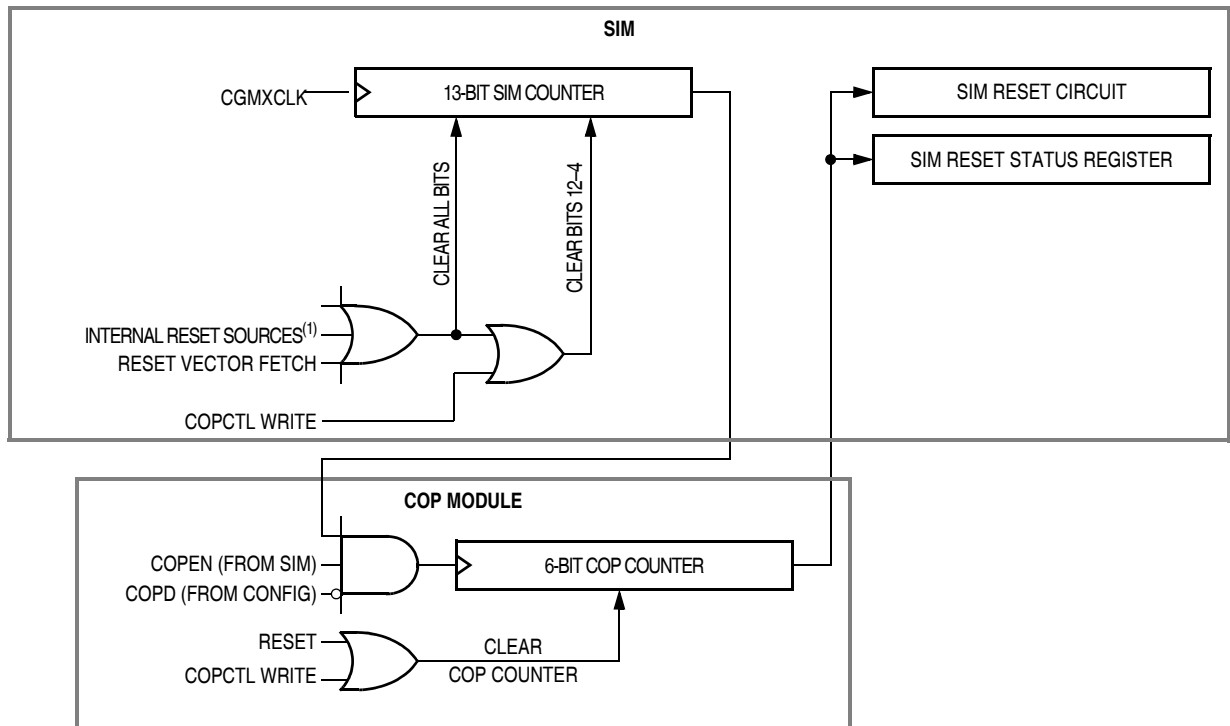
16.2	Introduction	333
16.3	Functional Description	334
16.4	I/O Signals	335
16.4.1	CGMXCLK	335
16.4.2	COPCTL Write	335
16.4.3	Power-On Reset	335
16.4.4	Internal Reset	336
16.4.5	Reset Vector Fetch	336
16.4.6	COPD (COP Disable)	336
16.5	COP Control Register	336
16.6	Interrupts	337
16.7	Monitor Mode	337
16.8	Wait Mode	337
16.9	COP Module During Break Mode	337

### 16.2 Introduction

This section describes the computer operating properly module (COP, Version B), a free-running counter that generates a reset if allowed to overflow. The COP module helps software recover from runaway code. Prevent a COP reset by periodically clearing the COP counter.

## 16.3 Functional Description

Figure 16-1 shows the structure of the COP module.



NOTE: See 7.4.2 Active Resets from Internal Sources.

Figure 16-1. COP Block Diagram

Addr.	Name	Bit 7	6	5	4	3	2	1	Bit 0
\$FFFF	COP Control Register (COPCTL)	Read: Low byte of reset vector							
		Write: Writing to \$FFFF clears COP counter							
		Reset: Unaffected by reset							

Figure 16-2. COP I/O Register Summary

The COP counter is a free-running 6-bit counter preceded by the 13-bit system integration module (SIM) counter. If not cleared by software, the COP counter overflows and generates an asynchronous reset after  $2^{18} - 2^4$  CGMXCLK cycles. With a 4.9152-MHz crystal, the COP timeout period is 53.3 ms. Writing any value to location \$FFFF before overflow occurs clears the COP counter and prevents reset.

A COP reset pulls the  $\overline{\text{RST}}$  pin low for 32 CGMXCLK cycles and sets the COP bit in the SIM reset status register (SRSR) (see [7.7.3 SIM Reset Status Register](#)).

**NOTE:** *Place COP clearing instructions in the main program and not in an interrupt subroutine. Such an interrupt subroutine could keep the COP from generating a reset even while the main program is not working properly.*

## 16.4 I/O Signals

The following paragraphs describe the signals shown in [Figure 16-1](#).

### 16.4.1 CGMXCLK

CGMXCLK is the crystal oscillator output signal. CGMXCLK frequency is equal to the crystal frequency.

### 16.4.2 COPCTL Write

Writing any value to the COP control register (COPCTL) (see [16.5 COP Control Register](#)) clears the COP counter and clears bits 12 through 4 of the SIM counter. Reading the COP control register returns the reset vector.

### 16.4.3 Power-On Reset

The power-on reset (POR) circuit in the SIM clears the SIM counter 4096 CGMXCLK cycles after power-up.

## 16.4.4 Internal Reset

An internal reset clears the SIM counter and the COP counter.

## 16.4.5 Reset Vector Fetch

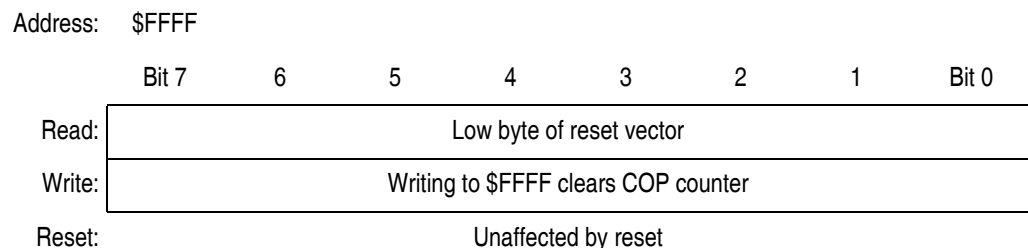
A reset vector fetch occurs when the vector address appears on the data bus. A reset vector fetch clears the SIM counter.

## 16.4.6 COPD (COP Disable)

The COPD signal reflects the state of the COP disable bit (COPD) in the configuration register (CONFIG). (See [Section 5. Configuration Register \(CONFIG\)](#).)

## 16.5 COP Control Register

The COP control register is located at address \$FFFF and overlaps the reset vector. Writing any value to \$FFFF clears the COP counter and starts a new timeout period. Reading location \$FFFF returns the low byte of the reset vector.



**Figure 16-3. COP Control Register (COPCTL)**



## 16.6 Interrupts

The COP does not generate CPU interrupt requests.

## 16.7 Monitor Mode

The COP is disabled in monitor mode when  $V_{DD} + V_{HI}$  is present on the  $\overline{IRQ1}/V_{PP}$  pin or on the  $\overline{RST}$  pin.

## 16.8 Wait Mode

The WAIT instruction puts the MCU in low-power-consumption standby mode.

The COP continues to operate during wait mode.

## 16.9 COP Module During Break Mode

The COP is disabled during a break interrupt when  $V_{DD} + V_{HI}$  is present on the  $\overline{RST}$  pin.



## Section 17. External Interrupt (IRQ)

### 17.1 Contents

17.2	Introduction	339
17.3	Features	339
17.4	Functional Description	340
17.5	$\overline{\text{IRQ1}}/V_{PP}$ Pin	343
17.6	IRQ Module During Break Mode	344
17.7	IRQ Status and Control Register	345

### 17.2 Introduction

This section describes the external interrupt module (IRQEPM, Version B), which supports external interrupt functions.

### 17.3 Features

Features of the IRQ module include:

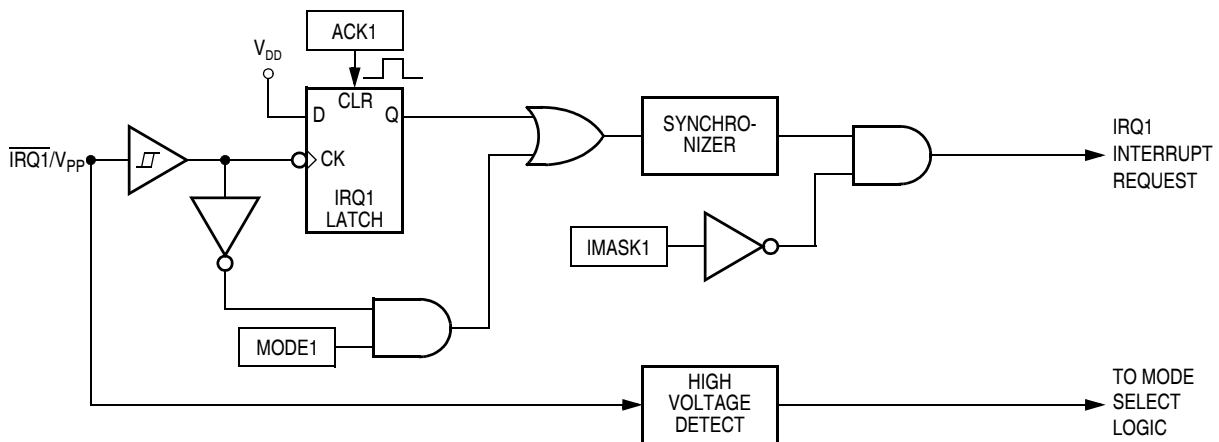
- A dedicated External Interrupt Pin ( $\overline{\text{IRQ1}}/V_{PP}$ )
- Hysteresis Buffers

## 17.4 Functional Description

A logic 0 applied to any of the external interrupt pins can latch a CPU interrupt request. **Figure 17-1** shows the structure of the IRQ module.

Interrupt signals on the  $\overline{\text{IRQ1}}/\text{V}_{\text{PP}}$  pin are latched into the IRQ1 latch. An interrupt latch remains set until one of the following actions occurs:

- Vector fetch — A vector fetch automatically generates an interrupt acknowledge signal that clears the latch that caused the vector fetch.
- Software clear — Software can clear an interrupt latch by writing to the appropriate acknowledge bit in the interrupt status and control register (ISCR). Writing a logic 1 to the ACK1 bit clears the IRQ1 latch.
- Reset — A reset automatically clears both interrupt latches.



**Figure 17-1. IRQ Module Block Diagram**

Addr.	Name	Bit 7	6	5	4	3	2	1	Bit 0	
\$001E	IRQ Status and Control Register (ISCR)	Read:	0	0	0	0	IRQ1F	0	IMASK1	MODE1
		Write:						ACK1		
		Reset:	0	0	0	0	0	0	0	0

**Figure 17-2. IRQ I/O Register Summary**

The external interrupt pins are falling-edge-triggered and are software-configurable to be both falling-edge and low-level-triggered. The MODE1 bit in the ISCR controls the triggering sensitivity of the  $\overline{\text{IRQ1}}/\text{V}_{\text{PP}}$  pin.

When the interrupt pin is edge-triggered only, the interrupt latch remains set until a vector fetch, software clear, or reset occurs.

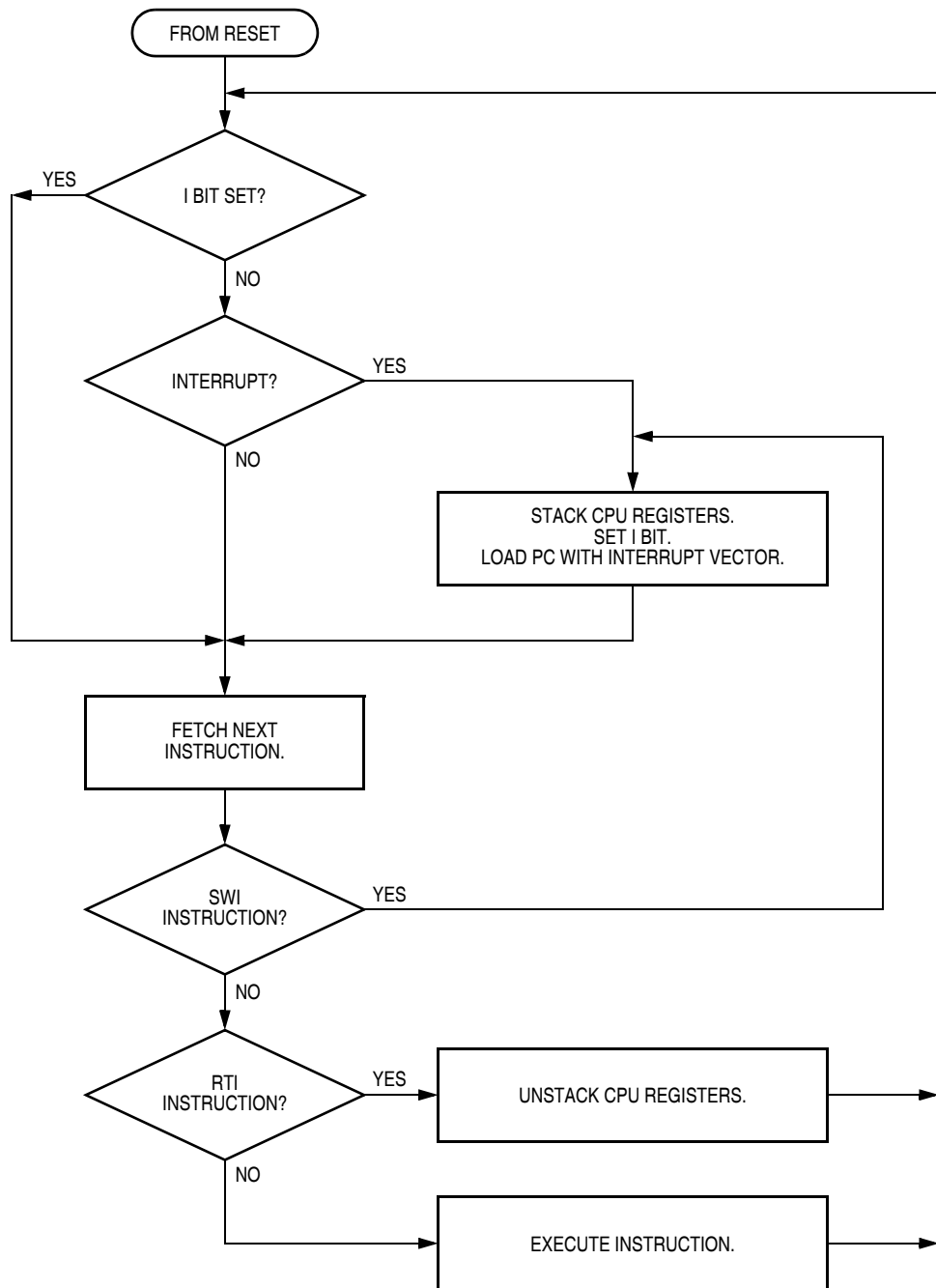
When the interrupt pin is both falling-edge and low-level-triggered, the interrupt latch remains set until both of the following occur:

- Vector fetch, software clear, or reset
- Return of the interrupt pin to logic 1

The vector fetch or software clear can occur before or after the interrupt pin returns to logic 1. As long as the pin is low, the interrupt request remains pending.

When set, the IMASK1 bit in the ISCR mask all external interrupt requests. A latched interrupt request is not presented to the interrupt priority logic unless the IMASK bit is clear.

**NOTE:** *The interrupt mask (I) in the condition code register (CCR) masks all interrupt requests, including external interrupt requests. (See [Figure 17-3](#).)*



**Figure 17-3. IRQ Interrupt Flowchart**

## 17.5 $\overline{\text{IRQ1}}/\text{V}_{\text{PP}}$ Pin

A logic 0 on the  $\overline{\text{IRQ1}}/\text{V}_{\text{PP}}$  pin can latch an interrupt request into the IRQ1 latch. A vector fetch, software clear, or reset clears the IRQ1 latch.

If the MODE1 bit is set, the  $\overline{\text{IRQ1}}/\text{V}_{\text{PP}}$  pin is both falling-edge-sensitive and low-level-sensitive. With MODE1 set, both of the following actions must occur to clear the IRQ1 latch:

- Vector fetch, software clear, or reset — A vector fetch generates an interrupt acknowledge signal to clear the latch. Software can generate the interrupt acknowledge signal by writing a logic 1 to the ACK1 bit in the interrupt status and control register (ISCR). The ACK1 bit is useful in applications that poll the  $\overline{\text{IRQ1}}/\text{V}_{\text{PP}}$  pin and require software to clear the IRQ1 latch. Writing to the ACK1 bit can also prevent spurious interrupts due to noise. Setting ACK1 does not affect subsequent transitions on the  $\overline{\text{IRQ1}}/\text{V}_{\text{PP}}$  pin. A falling edge that occurs after writing to the ACK1 bit latches another interrupt request. If the IRQ1 mask bit, IMASK1, is clear, the CPU loads the program counter with the vector address at locations \$FFFA and \$FFFB.
- Return of the  $\overline{\text{IRQ1}}/\text{V}_{\text{PP}}$  pin to logic 1 — As long as the  $\overline{\text{IRQ1}}/\text{V}_{\text{PP}}$  pin is at logic 0, the IRQ1 latch remains set.

The vector fetch or software clear and the return of the  $\overline{\text{IRQ1}}/\text{V}_{\text{PP}}$  pin to logic 1 can occur in any order. The interrupt request remains pending as long as the  $\overline{\text{IRQ1}}/\text{V}_{\text{PP}}$  pin is at logic 0.

If the MODE1 bit is clear, the  $\overline{\text{IRQ1}}/\text{V}_{\text{PP}}$  pin is falling-edge-sensitive only. With MODE1 clear, a vector fetch or software clear immediately clears the IRQ1 latch.

Use the BIH or BIL instruction to read the logic level on the  $\overline{\text{IRQ1}}/\text{V}_{\text{PP}}$  pin.

**NOTE:** *When using the level-sensitive interrupt trigger, avoid false interrupts by masking interrupt requests in the interrupt routine.*

### 17.6 IRQ Module During Break Mode

The system integration module (SIM) controls whether the IRQ1 interrupt latch can be cleared during the break state. The BCFE bit in the SIM break flag control register (SBFCR) enables software to clear the latches during the break state. (See [7.7.4 SIM Break Flag Control Register](#).)

To allow software to clear the IRQ1 latch during a break interrupt, write a logic 1 to the BCFE bit. If a latch is cleared during the break state, it remains cleared when the MCU exits the break state.

To protect the latches during the break state, write a logic 0 to the BCFE bit. With BCFE at logic 0 (its default state), writing to the ACK1 bit in the IRQ status and control register during the break state has no effect on the IRQ latches. (See [17.7 IRQ Status and Control Register](#).)




## 17.7 IRQ Status and Control Register

The IRQ status and control register (ISCR) has these functions:

- Clears the IRQ1 interrupt latch
- Masks IRQ1 interrupt requests
- Controls triggering sensitivity of the  $\overline{\text{IRQ1}}/\text{V}_{\text{PP}}$  interrupt pin

Address: \$001E

Read:	0	0	0	0	IRQ1F	0	IMASK1	MODE1
Write:						ACK1		
Reset:	0	0	0	0	0	0	0	0

 = Unimplemented

**Figure 17-4. IRQ Status and Control Register (ISCR)**

### ACK1 — IRQ1 Interrupt Request Acknowledge Bit

Writing a logic 1 to this write-only bit clears the IRQ1 latch. ACK1 always reads as logic 0. Reset clears ACK1.

### IMASK1 — IRQ1 Interrupt Mask Bit

Writing a logic 1 to this read/write bit disables IRQ1 interrupt requests. Reset clears IMASK1.

- 1 = IRQ1 interrupt requests disabled
- 0 = IRQ1 interrupt requests enabled

### MODE1 — IRQ1 Edge/Level Select Bit

This read/write bit controls the triggering sensitivity of the  $\overline{\text{IRQ1}}/\text{V}_{\text{PP}}$  pin. Reset clears MODE1.

- 1 =  $\overline{\text{IRQ1}}/\text{V}_{\text{PP}}$  interrupt requests on falling edges and low levels
- 0 =  $\overline{\text{IRQ1}}/\text{V}_{\text{PP}}$  interrupt requests on falling edges only

### IRQ1F — IRQ1 Flag

This read-only bit acts as a status flag, indicating an IRQ1 event occurred.

- 1 = External IRQ1 event occurred
- 0 = External IRQ1 event did not occur



## Section 18. Low-Voltage Inhibit (LVI)

### 18.1 Contents

18.2	Introduction	347
18.3	Features	347
18.4	Functional Description	348
18.4.1	Polled LVI Operation	349
18.4.2	Forced Reset Operation	349
18.4.3	False Reset Protection	349
18.5	LVI Status Register	350
18.6	LVI Interrupts	351
18.7	Wait Mode	351

### 18.2 Introduction

This section describes the low-voltage inhibit module (LVI47, Version A), which monitors the voltage on the  $V_{DD}$  pin and can force a reset when the  $V_{DD}$  voltage falls to the LVI trip voltage.

### 18.3 Features

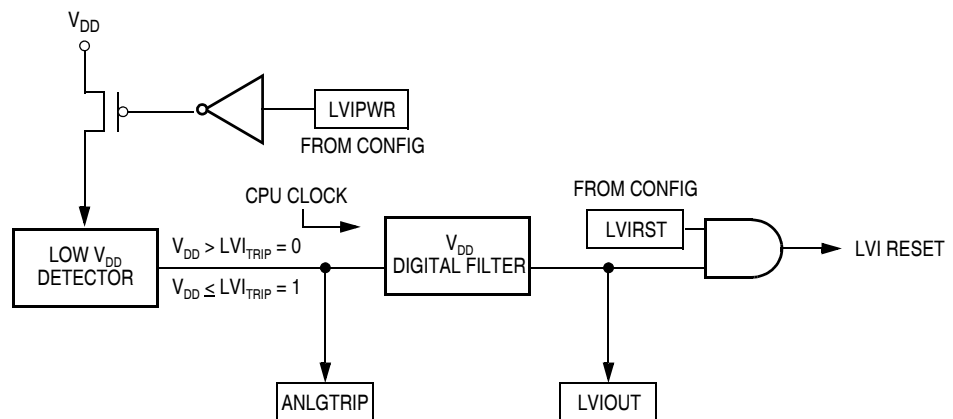
Features of the LVI module include:

- Programmable LVI Reset
- Programmable Power Consumption
- Digital Filtering of  $V_{DD}$  pin level

## 18.4 Functional Description


**Figure 18-1** shows the structure of the LVI module. The LVI is enabled out of reset. The LVI module contains a bandgap reference circuit and comparator. The LVI power bit, LVIPWR, enables the LVI to monitor  $V_{DD}$  voltage. The LVI reset bit, LVIRST, enables the LVI module to generate a reset when  $V_{DD}$  falls below a voltage,  $V_{DD\_TRIP}$ , and remains at or below that level for nine or more consecutive CPU cycles. LVIPWR and LVIRST are in the configuration register (CONFIG). (See **Section 5. Configuration Register (CONFIG)**.) Once an LVI reset occurs, the MCU remains in reset until  $V_{DD}$  rises above a voltage,  $V_{DD\_TRIPR}$ .  $V_{DD}$  must be above  $V_{DD\_TRIPR}$  for only one CPU cycle to bring the MCU out of reset. (See **7.4.2.5 Low-Voltage Inhibit (LVI) Reset**.) The output of the comparator controls the state of the LVIOUT flag in the LVI status register (LVISR).

An LVI reset also drives the  $\overline{RST}$  pin low to provide low-voltage protection to external peripheral devices.



**Figure 18-1. LVI Module Block Diagram**

Addr.	Name	Bit 7	6	5	4	3	2	1	Bit 0
\$FE0F	LVI Status Register (LVISR)	Read:	LVIOUT	0	0	0	0	0	0
		Write:							
		Reset:	0	0	0	0	0	0	0

 = Unimplemented

**Figure 18-2. LVI I/O Register Summary**

### 18.4.1 Polled LVI Operation

In applications that can operate at  $V_{DD}$  levels below the  $LVI_{TRIPF}$  level, software can monitor  $V_{DD}$  by polling the LVIOUT bit. In the configuration register, the LVIPWR bit must be at logic 0 to enable the LVI module, and the LVIRST bit must be at logic 1 to disable LVI resets.

### 18.4.2 Forced Reset Operation

In applications that require  $V_{DD}$  to remain above the  $LVI_{TRIPF}$  level, enabling LVI resets allows the LVI module to reset the MCU when  $V_{DD}$  falls to the  $LVI_{TRIPF}$  level and remains at or below that level for nine or more consecutive CPU cycles. In the configuration register, the LVIPWR and LVIRST bits must be at logic 0 to enable the LVI module and to enable LVI resets.

### 18.4.3 False Reset Protection


The  $V_{DD}$  pin level is digitally filtered to reduce false resets due to power supply noise. In order for the LVI module to reset the MCU,  $V_{DD}$  must remain at or below the  $LVI_{TRIPF}$  level for nine or more consecutive CPU cycles.  $V_{DD}$  must be above  $LVI_{TRIPR}$  for only one CPU cycle to bring the MCU out of reset.

## 18.5 LVI Status Register

The LVI status register (LVISR) flags  $V_{DD}$  voltages below the  $LVI_{TRIPF}$  level.

Address: \$FE0F

	Bit 7	6	5	4	3	2	1	Bit 0
Read:	LVIOUT	0	0	0	0	0	0	0
Write:								
Reset:	0	0	0	0	0	0	0	0

 = Unimplemented

**Figure 18-3. LVI Status Register (LVISR)**

### LVIOUT — LVI Output Bit

This read-only flag becomes set when the  $V_{DD}$  voltage falls below the  $LVI_{TRIPF}$  voltage for 32 to 40 CGMXCLK cycles. (See [Table 18-1.](#)) Reset clears the LVIOUT bit.

**Table 18-1. LVIOUT Bit Indication**

$V_{DD}$		LVIOUT
At Level:	For Number of CGMXCLK Cycles:	
$V_{DD} > LVI_{TRIPR}$	ANY	0
$V_{DD} < LVI_{TRIPF}$	< 32 CGMXCLK cycles	0
$V_{DD} < LVI_{TRIPF}$	between 32 & 40 CGMXCLK cycles	0 or 1
$V_{DD} < LVI_{TRIPF}$	> 40 CGMXCLK cycles	1
$LVI_{TRIPF} < V_{DD} < LVI_{TRIPR}$	ANY	Previous Value

## 18.6 LVI Interrupts

The LVI module does not generate interrupt requests.

## 18.7 Wait Mode

The WAIT instruction puts the MCU in low-power-consumption standby mode.

With the LVIPWR bit in the configuration register programmed to logic 0, the LVI module is active after a WAIT instruction.

With the LVIRST bit in the configuration register programmed to logic 0, the LVI module can generate a reset and bring the MCU out of wait mode.





## Section 19. Analog-to-Digital Converter (ADC)

### 19.1 Contents

19.2	Introduction	354
19.3	Features	354
19.4	Functional Description	354
19.4.1	ADC Port I/O Pins	356
19.4.2	Voltage Conversion	356
19.4.3	Conversion Time	356
19.4.4	Continuous Conversion	357
19.4.5	Accuracy and Precision	357
19.5	Interrupts	357
19.6	Wait Mode	357
19.7	I/O Signals	358
19.7.1	ADC Analog Power Pin ( $V_{DDAD}$ )	358
19.7.2	ADC Analog Ground Pin ( $V_{SSAD}$ )	358
19.7.3	ADC Voltage Reference Pin ( $V_{DDAREF}$ )	358
19.7.4	ADC Voltage Decoupling Capacitor Pin ( $V_{ADCAP}$ )	358
19.7.5	ADC Voltage Reference Low Pin ( $V_{REFL}$ )	359
19.7.6	ADC Voltage In (ADVIN)	359
19.8	I/O Registers	359
19.8.1	ADC Status and Control Register	360
19.8.2	ADC Data Register	363
19.8.3	ADC Clock Register	363

## 19.2 Introduction

This section describes the analog-to-digital convertor. The ADC is an 8-bit analog-to-digital convertor.

## 19.3 Features

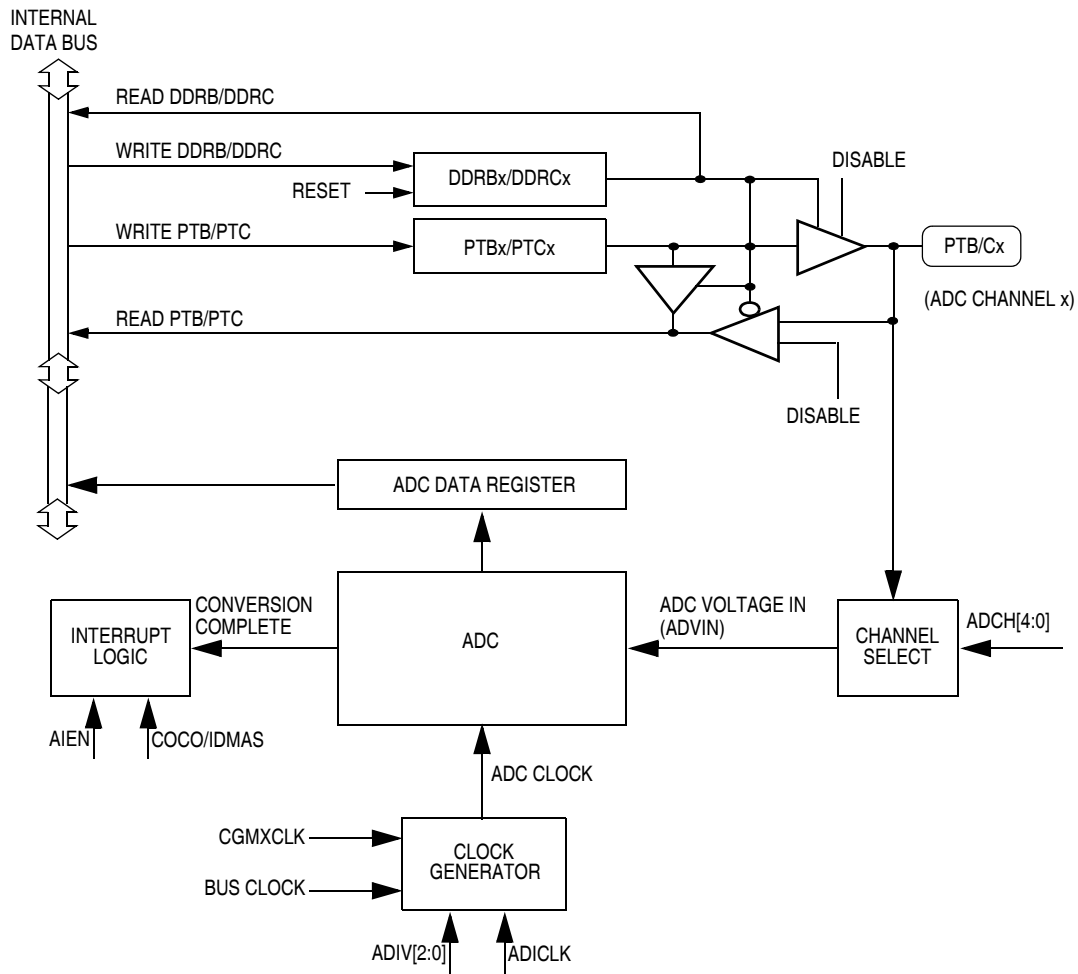
Features of the ADC module include:

- 10 channels with multiplexed input
- Linear successive approximation
- 8-bit resolution
- Single or continuous conversion
- Conversion complete flag or conversion complete interrupt
- Selectable ADC Clock

## 19.4 Functional Description

Ten ADC channels are available for sampling external sources at pins PTC1/ATD9:PTC0/ATD8 and PTB7/ATD7:PTB0/ATD0. An analog multiplexer allows the single ADC converter to select one of the 10 ADC channels as ADC voltage IN (ADCVIN). ADCVIN is converted by the successive approximation register based counter. When the conversion is completed, the ADC places the result in the ADC data register and sets a flag or generates an interrupt. (See [Figure 19-1.](#))

**NOTE:** *DMA section and associated functions are only valid if the MCU has a DMA module.*



**Figure 19-1. ADC Block Diagram**

## 19.4.1 ADC Port I/O Pins

PTC1/ATD9:PTC0/ATD8 and PTB7/ATD7:PTB0/ATD0 are general-purpose I/O pins that are shared with the ADC channels.

The channel select bits define which ADC channel/port pin will be used as the input signal. The ADC overrides the port I/O logic by forcing that pin as input to the ADC. The remaining ADC channels/port pins are controlled by the port I/O logic and can be used as general-purpose I/O. Writes to the port register or DDR will not have any affect on the port pin that is selected by the ADC. Read of a port pin which is in use by the ADC will return a logic 0.

## 19.4.2 Voltage Conversion

When the input voltage to the ADC equals  $V_{DDAD}$ , the ADC converts the signal to \$FF (full scale). If the input voltage equals  $V_{SSAD}$ , the ADC converts it to \$00. Input voltages between  $V_{DDAD}$  and  $V_{SSAD}$  are straight-line linear conversions. All other input voltages will result in \$FF if greater than  $V_{DDAD}$  and \$00 if less than  $V_{SSAD}$ .

**NOTE:** *Input voltage should not exceed the analog supply voltages.*

## 19.4.3 Conversion Time

Conversion starts after a write to the ADSCR. Conversion time in terms of the number of bus cycles is a function of oscillator frequency, bus frequency, and ADIV prescaler bits. For example, with an oscillator frequency of 8 MHz, a bus frequency of 4 MHz, and an ADC clock frequency of 1 MHz, one conversion will take between 16 ADC and 17 ADC clock cycles or between 16 and 17  $\mu$ s. There will be 128 bus cycles between each conversion. Sample rate is approximately 30 kHz.

$$\text{Conversion Time} = \frac{16-17 \text{ ADC Cycles}}{\text{ADC Frequency}}$$

$$\text{Number of Bus Cycles} = \text{Conversion Time} \times \text{Bus Frequency}$$

#### 19.4.4 Continuous Conversion

In the continuous conversion mode, the ADC data register will be filled with new data after each conversion. Data from the previous conversion will be overwritten whether that data has been read or not. Conversions will continue until the ADCO bit is cleared. The COCO bit is set after the first conversion and will stay set for the next several conversions until the next write of the ADC status and control register or the next read of the ADC data register.

#### 19.4.5 Accuracy and Precision

The conversion process is monotonic and has no missing codes.

### 19.5 Interrupts

When the AIEN bit is set, the ADC module is capable of generating either CPU or DMA interrupt after each ADC conversion. A CPU interrupt is generated if the COCO/IDMAS bit is at logic 0. If COCO/IDMAS bit is set, a DMA interrupt is generated. The COCO/IDMAS bit is not used as a conversion complete flag when interrupts are enabled.

### 19.6 Wait Mode

The WAIT instruction can put the MCU in low-power-consumption standby mode.

The ADC continues normal operation during wait mode. Any enabled CPU interrupt request from the ADC can bring the MCU out of wait mode. If the ADC is not required to bring the MCU out of wait mode, power down the ADC by setting ADCH[4:0] bits in the ADC status and Control Register before executing the WAIT instruction.

## 19.7 I/O Signals

The ADC module has 10 I/O signals that are shared with port B and port C.

### 19.7.1 ADC Analog Power Pin ( $V_{DDAD}$ )

The ADC analog portion uses  $V_{DDAD}$  as its power pin. Connect the  $V_{DDAD}$  pin to the same voltage potential as  $V_{DD}$ . External filtering may be necessary to ensure clean  $V_{DDAD}$  for good results.

**NOTE:** *Route  $V_{DDAD}$  carefully for maximum noise immunity and place bypass capacitors as close as possible to the package.*

### 19.7.2 ADC Analog Ground Pin ( $V_{SSAD}$ )

The ADC analog portion uses  $V_{SSAD}$  as its ground pin. Connect the  $V_{SSAD}$  pin to the same voltage potential as  $V_{SS}$ .

### 19.7.3 ADC Voltage Reference Pin ( $V_{DDAREF}$ )

$V_{DDAREF}$  is the power supply for setting the reference voltage  $V_{REFH}$ . Connect the  $V_{DDAREF}$  pin to the same voltage potential as  $V_{DDA}$ .

### 19.7.4 ADC Voltage Decoupling Capacitor Pin ( $V_{ADCAP}$ )

$V_{ADCAP}$  is one of two reference supplies and is generated from  $V_{DDAREF}$  with a value  $(V_{DDAREF})/2$ . Place a bypass capacitor on this pin to decouple noise.  $V_{ADCAP}$  pin can also be used to drive an upper reference value of  $(V_{DDAREF})/2$  with an external voltage reference.

### 19.7.5 ADC Voltage Reference Low Pin ( $V_{REFL}$ )

$V_{REFL}$  is the lower reference supply for the ADC. Connect the  $V_{REFL}$  pin to the same voltage potential as  $V_{SSAD}$ .

### 19.7.6 ADC Voltage In (ADVIN)

ADVIN is the input voltage signal from one of the 10 ADC channels to the ADC module.

## 19.8 I/O Registers

The following I/O registers control and monitor operation of the ADC:

- ADC status and control register (ADSCR)
- ADC data register (ADR)
- ADC clock register (ADCLK)

## 19.8.1 ADC Status and Control Register

These paragraphs describe the function of the ADC status and control register (ADSCR).

Address: \$0017

	Bit 7	6	5	4	3	2	1	Bit 0
Read:	COCO/ IDMAS	AIEN	ADCO	ADCH4	ADCH3	ADCH2	ADCH1	ADCH0
Write:								
Reset:	0	0	0	0	0	0	0	0

**Figure 19-2. ADC Status and Control Register (ADSCR)**

### COCO/IDMAS — Conversions Complete / Interrupt DMA Select

When AIEN bit is a logic 0, the COCO/IDMAS is a read-only bit which is set each time a conversion is completed except in the continuous conversion mode where it is set after the first conversion. This bit is cleared whenever the ADC status and control register is written or whenever the ADC data register is read.

If AIEN bit is a logic 1, the COCO/IDMAS is a read/write bit which selects either CPU or DMA to service the ADC interrupt request. Reset clears this bit.

- 1 = Conversion completed (AIEN = 0)/DMA interrupt (AIEN = 1)
- 0 = Conversion not completed (AIEN = 0)/CPU interrupt (AIEN = 1)

### AIEN — ADC Interrupt Enable

When this bit is set, an interrupt is generated at the end of an ADC conversion. The interrupt signal is cleared when the data register is read or the status/control register is written. Reset clears the AIEN bit.

- 1 = ADC interrupt enabled
- 0 = ADC interrupt disabled



### ADCO — ADC Continuous Conversion

When set, the ADC will convert samples continuously and update the ADR register at the end of each conversion. Only one conversion is allowed when this bit is cleared. Reset clears the ADCO bit.

1 = Continuous ADC conversion

0 = One ADC conversion

### ADCH[4:0] — ADC Channel Select Bits

ADCH4, ADCH3, ADCH2, ADCH1, and ADCH0 form a 5-bit field which is used to select one of 14 ADC channels. The 14 channels are detailed in [Table 19-1](#). Take care to prevent switching noise from corrupting the analog signal when simultaneously using a port pin as both an analog and digital input. (See [Table 19-1](#).)

The ADC subsystem is turned off when the channel select bits are all set to one. This feature allows for reduced power consumption for the MCU when the ADC is not used.

**NOTE:** *Recovery from the disabled state requires one conversion cycle to stabilize.*

The voltage levels supplied from internal reference nodes as specified in [Table 19-1](#) are used to verify the operation of the ADC converter both in production test and for user applications.

**Table 19-1. Mux Channel Select**

ADCH4	ADCH3	ADCH2	ADCH1	ADCH0	Input Select
0	0	0	0	0	PTB0/ATD0
0	0	0	0	1	PTB1/ATD1
0	0	0	1	0	PTB2/ATD2
0	0	0	1	1	PTB3/ATD3
0	0	1	0	0	PTB4/ATD4
0	0	1	0	1	PTB5/ATD5
0	0	1	1	0	PTB6/ATD6
0	0	1	1	1	PTB7/ATD7
0	1	0	0	0	PTC0/ATD8
0	1	0	0	1	PTC1/ATD9
0	1	0	1	0	Unused <sup>(2)</sup>
0	1	0	1	1	∅
0	1	1	0	0	∅
0	1	1	0	1	∅
0	1	1	1	0	∅
0	1	1	1	1	∅
1	0	0	0	0	↓
1	1	0	1	0	Unused <sup>(1)</sup>
1	1	0	1	1	Reserved <sup>(2)</sup>
1	1	1	0	0	2*V <sub>ADCAP</sub>
1	1	1	0	1	V <sub>ADCAP</sub>
1	1	1	1	0	2*V <sub>REFL</sub>
1	1	1	1	1	[ADC power off]

**Notes:**


1. If any unused channels are selected, the resulting ADC conversion will be unknown.
2. Used for factory testing.

## 19.8.2 ADC Data Register

One 8-bit result register is provided. This register is updated each time an ADC conversion completes.

Address: \$0019

	Bit 7	6	5	4	3	2	1	Bit 0
Read:	AD7	AD6	AD5	AD4	AD3	AD2	AD1	AD0
Write:								
Reset:	0	0	0	0	0	0	0	0

 = Unimplemented


**Figure 19-3. ADC Data Register (ADR)**

## 19.8.3 ADC Clock Register

This register selects the clock frequency for the ADC.

Address: \$001A

	Bit 7	6	5	4	3	2	1	Bit 0
Read:	ADIV2	ADIV1	ADIV0	ADCLK	0	0	0	0
Write:								
Reset:	0	0	0	0	0	0	0	0

 = Unimplemented

**Figure 19-4. ADC Clock Register (ADCLKR)**

### ADIV2:ADIV0 — ADC Clock Prescaler Bits

ADIV2, ADIV1, and ADIV0 form a 3-bit field which selects the divide ratio used by the ADC to generate the internal ADC clock.

**Table 19-2** shows the available clock configurations. The ADC clock should be set to 1 MHz.

**Table 19-2. ADC Clock Divide Ratio**

ADIV2	ADIV1	ADIV0	ADC Clock Rate
0	0	0	ADC input clock /1
0	0	1	ADC input clock /2
0	1	0	ADC input clock /4
0	1	1	ADC input clock /8
1	X	X	ADC input clock /16

X = don't care

## ADICLK — ADC Input Clock Select

ADICLK selects either bus clock or CGMXCLK as the input clock source to generate the internal ADC clock. Reset selects CGMXCLK as the ADC clock source.

If the external clock (CGMXCLK) is equal or greater than 1 MHz, CGMXCLK can be used as the clock source for the ADC. If CGMXCLK is less than 1 MHz, use the PLL-generated bus clock as the clock source. As long as the internal ADC clock is at 1 MHz, correct operation can be guaranteed. (See [21.11 Analog-to-Digital Converter \(ADC\) Characteristics](#).)

1 = Internal bus clock

0 = External clock (CGMXCLK)

$$1 \text{ MHz} = \frac{\text{CGMXCLK or Bus Frequency}}{\text{ADIV}[2:0]}$$

## Section 20. Power-On Reset (POR)

### 20.1 Contents

20.2	Introduction . . . . .	365
20.3	Functional Description . . . . .	365

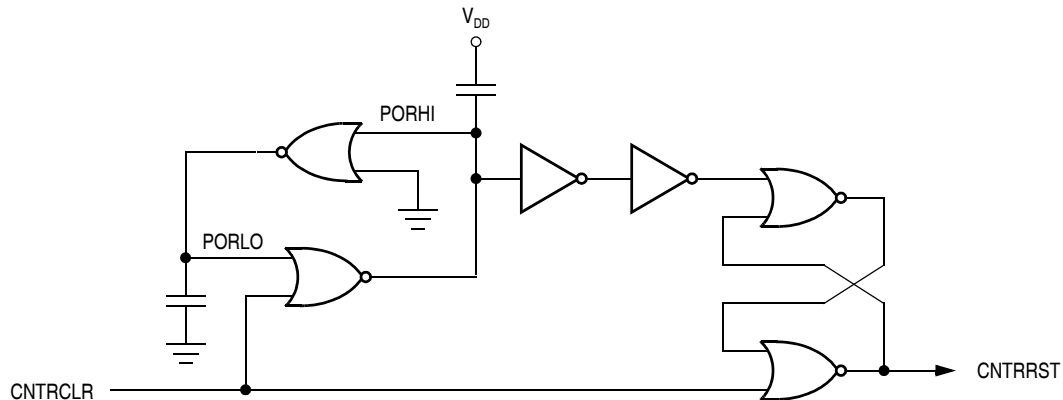
### 20.2 Introduction

This section describes the power-on reset (POR) module (Version B).

### 20.3 Functional Description

The POR module provides a known, stable signal to the MCU at power-on. This signal tracks  $V_{DD}$  until the MCU generates a feedback signal to indicate that it is properly initialized. At this time, the POR drives its output low. The POR is not a brown-out detector, low-voltage detector, or glitch detector.  $V_{DD}$  at the POR must go completely to zero to reset the MCU. To detect power-loss conditions, use a low voltage inhibit module (LVI) or other suitable circuit. Inputs to the POR\_B00 are SIMINIT and SECZDET from the SIM and EPROM security circuits, respectively.

## Power-On Reset (POR)



**NOTES:**

1. PORHI goes high at power-up and is cleared when the SIM sets CNTRCLR.
2. Signal names are not necessarily accurate. This diagram is for logical illustration only and may not represent actual circuitry.

**Figure 20-1. POR Block Diagram**

## Section 21. Electrical Specifications

### 21.1 Contents

21.2	Introduction . . . . .	367
21.3	Absolute Maximum Ratings . . . . .	368
21.4	Functional Operating Range. . . . .	369
21.5	Thermal Characteristics . . . . .	369
21.6	DC Electrical Characteristics . . . . .	370
21.7	Control Timing . . . . .	371
21.8	Serial Peripheral Interface Characteristics . . . . .	372
21.9	Timer Interface Module Characteristics . . . . .	375
21.10	Clock Generation Module Electrical Characteristics. . . . .	375
21.11	Analog-to-Digital Converter (ADC) Characteristics. . . . .	377
21.12	Memory Characteristics . . . . .	377

### 21.2 Introduction

This section contains electrical and timing specifications. These values are design targets and have not yet been fully characterized.

## 21.3 Absolute Maximum Ratings

Maximum ratings are the extreme limits to which the MCU can be exposed without permanently damaging it.

**NOTE:** *This device is not guaranteed to operate properly at the maximum ratings. Refer to [21.6 DC Electrical Characteristics](#) for guaranteed operating conditions.*

**Table 21-1. Absolute Maximum Ratings<sup>(1)</sup>**

Characteristic	Symbol	Value	Unit
Supply Voltage	$V_{DD}$	-0.3 to +6.0	V
Input Voltage	$V_{IN}$	$V_{SS} - 0.3$ to $V_{DD} + 0.3$	V
Programming Voltage	$V_{PP}$	$V_{SS} - 0.3$ to 14.0	V
Maximum Current Per Pin Excluding $V_{DD}$ and $V_{SS}$	I	± 25	mA
Storage Temperature	$T_{STG}$	-55 to +150	°C
Maximum Current Out of $V_{SS}$	$I_{MVSS}$	100	mA
Maximum Current Into $V_{DD}$	$I_{MVDD}$	100	mA

Note:

1. Voltages referenced to  $V_{SS}$ .

**NOTE:** *This device contains circuitry to protect the inputs against damage due to high static voltages or electric fields; however, it is advised that normal precautions be taken to avoid application of any voltage higher than maximum-rated voltages to this high-impedance circuit. For proper operation, it is recommended that  $V_{IN}$  and  $V_{OUT}$  be constrained to the range  $V_{SS} \leq (V_{IN} \text{ or } V_{OUT}) \leq V_{DD}$ . Reliability of operation is enhanced if unused inputs are connected to an appropriate logic voltage level (for example, either  $V_{SS}$  or  $V_{DD}$ .)*



## 21.4 Functional Operating Range

**Table 21-2. Operating Range**

Characteristic	Symbol	Value	Unit
Operating Temperature Range (see Note) MC68HC708MP16CFU MC68HC708MP16VFU	$T_A$	–40 to 85 –40 to 105	°C
Operating Voltage Range	$V_{DD}$	$5.0 \pm 10\%$	V

Note:

See Freescale representative for temperature availability.

C = Extended temperature range (–40 to +85 °C)

V = Automotive temperature range (–40 to +105 °C)

## 21.5 Thermal Characteristics

**Table 21-3. Thermal Characteristics**

Characteristic	Symbol	Value	Unit
Thermal Resistance, QFP (64 Pin)	$\theta_{JA}$	76	°C/W
I/O Pin Power Dissipation	$P_{I/O}$	User Determined	W
Power Dissipation <sup>(1)</sup>	$P_D$	$P_D = (I_{DD} \times V_{DD}) + P_{I/O} =$ $K/(T_J + 273 \text{ °C})$	W
Constant <sup>(2)</sup>	K	$P_D \times (T_A + 273 \text{ °C})$ $+ P_D^2 \times \theta_{JA}$	W/°C
Average Junction Temperature	$T_J$	$T_A + (P_D \times \theta_{JA})$	°C
Maximum Junction Temperature	$T_{JM}$	125	°C

Notes:

1. Power dissipation is a function of temperature.

2. K is a constant unique to the device. K can be determined for a known  $T_A$  and measured  $P_D$ . With this value of K,  $P_D$  and  $T_J$  can be determined for any value of  $T_A$ .

## 21.6 DC Electrical Characteristics

**Table 21-4. DC Electrical Characteristics ( $V_{DD} = 5.0 \text{ Vdc} \pm 10\%$ )<sup>(1)</sup>**

Characteristic	Symbol	Min	Typ <sup>(2)</sup>	Max	Unit
Output High Voltage ( $I_{LOAD} = -2.0 \text{ mA}$ ) All I/O Pins	$V_{OH}$	$V_{DD} - 0.8$	—	—	V
Output Low Voltage ( $I_{LOAD} = 1.6 \text{ mA}$ ) All I/O Pins	$V_{OL}$	—	—	0.4	V
PWM Pin Output Source Current ( $V_{OH} = V_{DD} - 0.8 \text{ V}$ )	$I_{OH}$	7	—	—	mA
PWM Pin Output Sink Current ( $V_{OL} = 0.8 \text{ V}$ )	$I_{OL}$	-20	—	—	mA
Input High Voltage All ports, IRQs, RESET, OSC1	$V_{IH}$	$0.7 \times V_{DD}$	—	$V_{DD}$	V
Input Low Voltage All ports, IRQs, RESET, OSC1	$V_{IL}$	$V_{SS}$	—	$0.3 \times V_{DD}$	V
$V_{DD}$ Supply Current Run <sup>(3)</sup> Wait <sup>(4)</sup> Quiescent <sup>(5)</sup>	$I_{DD}$	— — —	— — —	40 14 750	mA mA $\mu\text{A}$
I/O Ports Hi-Z Leakage Current	$I_{IL}$	—	—	$\pm 10$	$\mu\text{A}$
Input Current	$I_{IN}$	—	—	$\pm 1$	$\mu\text{A}$
Capacitance Ports (as Input or Output)	$C_{OUT}$ $C_{IN}$	— —	— —	12 8	pF
Low-Voltage Inhibit Reset	$V_{LVR}$	4.33	4.45	4.58	V
Low-Voltage Reset/Recover Hysteresis	$H_{LVR}$	50	100	150	mV
POR ReArm Voltage <sup>(6)*</sup>	$V_{POR}$	0	—	100	mV
POR Rise Time Ramp Rate <sup>(8)</sup>	$R_{POR}$	0.035	—	—	V/ms

**Notes:**

- $V_{DD} = 5.0 \text{ Vdc} \pm 10\%$ ,  $V_{SS} = 0 \text{ Vdc}$ ,  $T_A = T_L$  to  $T_H$ , unless otherwise noted.
- Typical values reflect average measurements at midpoint of voltage range, 25 °C only.
- Run (operating)  $I_{DD}$  measured using external square wave clock source ( $f_{osc} = 8.2 \text{ MHz}$ ). All inputs 0.2 V from rail. No dc loads. Less than 100 pF on all outputs.  $C_L = 20 \text{ pF}$  on OSC2. All ports configured as inputs. OSC2 capacitance linearly affects run  $I_{DD}$ . Measured with all modules enabled.
- Wait  $I_{DD}$  measured using external square wave clock source ( $f_{osc} = 8.2 \text{ MHz}$ ); all inputs 0.2 V from rail; no dc loads; less than 100 pF on all outputs.  $C_L = 20 \text{ pF}$  on OSC2; all ports configured as inputs; OSC2 capacitance linearly affects wait  $I_{DD}$ ; measured with PLL, and LVI enabled.
- Quiescent  $I_{DD}$  measured with PLL and LVI disengaged, OCS1 grounded, no port pins sourcing current. Measured through combination of  $V_{DD}$ ,  $V_{DDAD}$ , and  $V_{DDA}$ .
- Maximum is highest voltage that POR is guaranteed.
- Maximum is highest voltage that POR is possible.
- If minimum  $V_{DD}$  is not reached before the internal POR reset is released,  $\overline{RST}$  must be driven low externally until minimum  $V_{DD}$  is reached.

## 21.7 Control Timing

**Table 21-5. Control Timing ( $V_{DD} = 5.0 \text{ Vdc} \pm 10\%$ )(<sup>1</sup>)**

Characteristic	Symbol	Min	Max	Unit
Frequency of Operation( <sup>2</sup> ) Crystal Option External Clock Option( <sup>3</sup> )	$f_{OSC}$	1 M dc( <sup>4</sup> )	8 M 32.8 M	Hz
Internal Operating Frequency	$f_{OP}$	—	8.2	MHz
$\overline{RESET}$ Input Pulse Width Low( <sup>5</sup> )	$t_{IRL}$	50	—	ns

Notes:

1.  $V_{SS} = 0 \text{ Vdc}$ ; timing shown with respect to 20%  $V_{DD}$  and 70%  $V_{DD}$ , unless otherwise noted.
2. See [Table 21-8](#) and [Table 21-9](#) for more information.
3. No more than 10% duty cycle deviation from 50%.
4. Some modules may require a minimum frequency greater than dc for proper operation; see appropriate table for this information.
5. Minimum pulse width reset is guaranteed to be recognized. It is possible for a smaller pulse width to cause a reset.

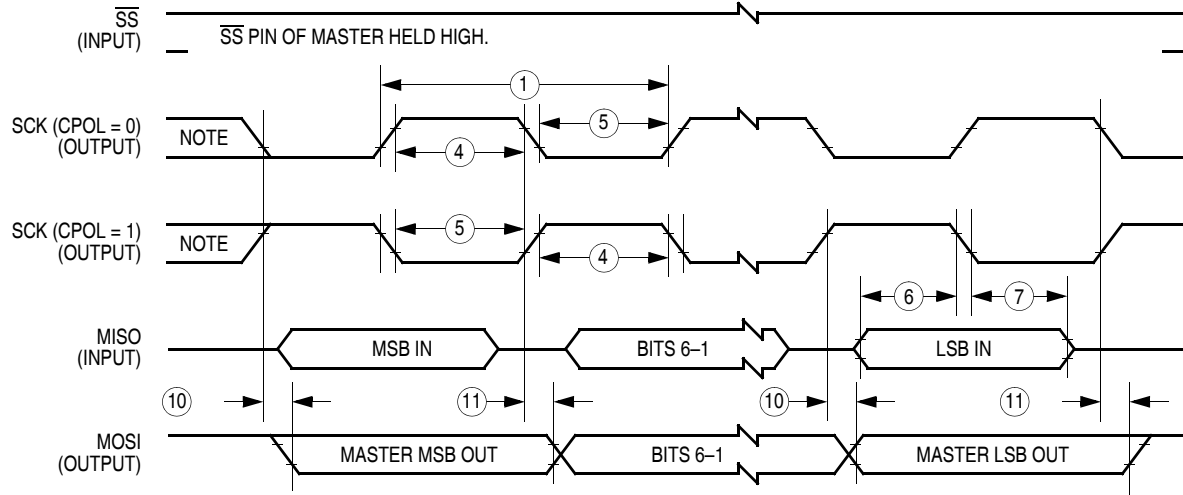
## 21.8 Serial Peripheral Interface Characteristics

**Table 21-6. Serial Peripheral Interface (SPI) Timing ( $V_{DD} = 5.0 \text{ Vdc} \pm 10\%$ ) <sup>(1)</sup>**

Diagram Number <sup>(2)</sup>	Characteristic	Symbol	Min	Max	Unit
	Operating Frequency Master Slave	$f_{OP(M)}$ $f_{OP(S)}$	$f_{OP/128}$ DC	$f_{OP/2}$ $f_{OP}$	MHz
1	Cycle Time Master Slave	$t_{CYC(M)}$ $t_{CYC(S)}$	2 1	128 —	$t_{CYC}$
2	Enable Lead Time	$t_{LEAD(S)}$	15	—	ns
3	Enable Lag Time	$t_{LAG(S)}$	15	—	ns
4	Clock (SCK) High Time Master Slave	$t_{SCKH(M)}$ $t_{SCKH(S)}$	100 50	— —	ns
5	Clock (SCK) Low Time Master Slave	$t_{SCKL(M)}$ $t_{SCKL(S)}$	100 50	— —	ns
6	Data Setup Time (Inputs) Master Slave	$t_{SU(M)}$ $t_{SU(S)}$	45 5	— —	ns
7	Data Hold Time (Inputs) Master Slave	$t_{H(M)}$ $t_{H(S)}$	0 15	— —	ns
8	Access Time, Slave <sup>(3)</sup> CPHA = 0 CHPA = 1	$t_{A(CP0)}$ $t_{A(CP1)}$	0 0	40 20	ns
9	Disable Time, Slave <sup>(4)</sup>	$t_{DIS(S)}$	—	25	ns
10	Data Valid Time (After Enable Edge) Master Slave <sup>(5)</sup>	$t_{V(M)}$ $t_{V(S)}$	— —	10 40	ns

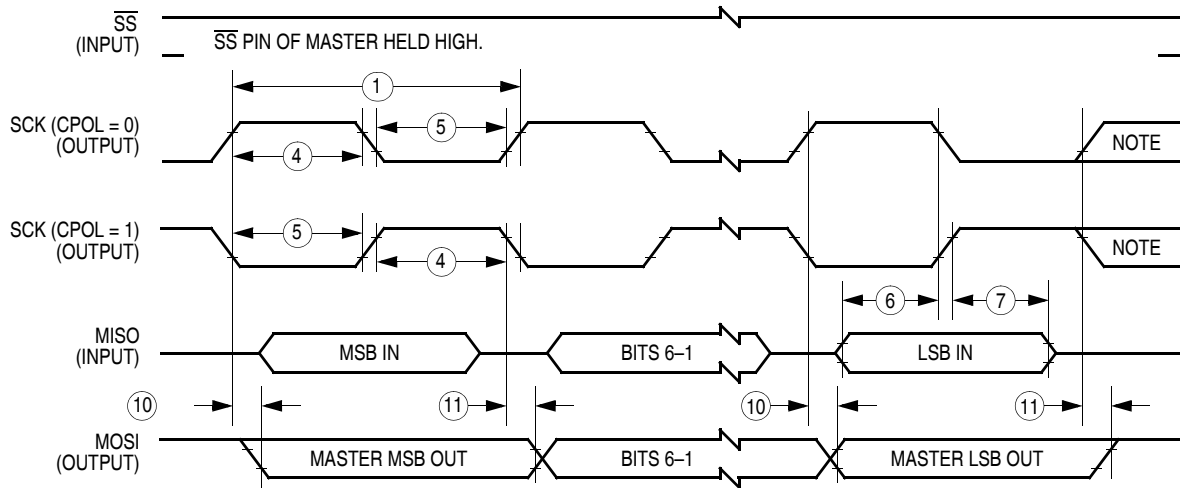
**Notes:**

1. All timing is shown with respect to 20%  $V_{DD}$  and 70%  $V_{DD}$ , unless otherwise noted; assumes 100 pF load on all SPI pins.
2. Numbers refer to dimensions in [Figure 21-1](#) and [Figure 21-2](#).
3. Time to data active from high-impedance state.
4. Hold time to high-impedance state.
5. With 100 pF on all SPI pins.



NOTE: This first clock edge is generated internally, but is not seen at the SCK pin.

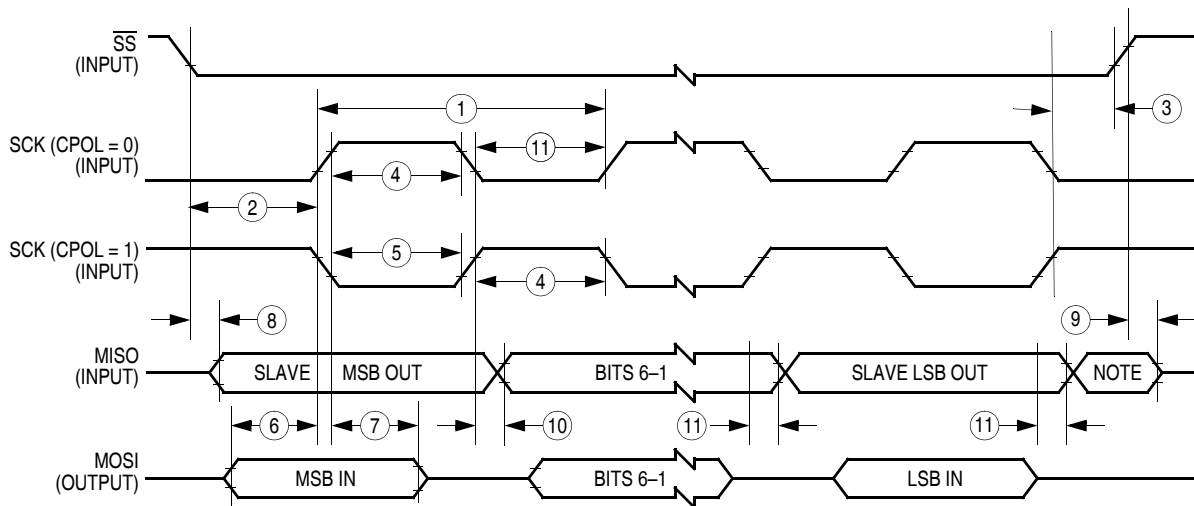
**a) SPI Master Timing (CPHA = 0)**



NOTE: This last clock edge is generated internally, but is not seen at the SCK pin.

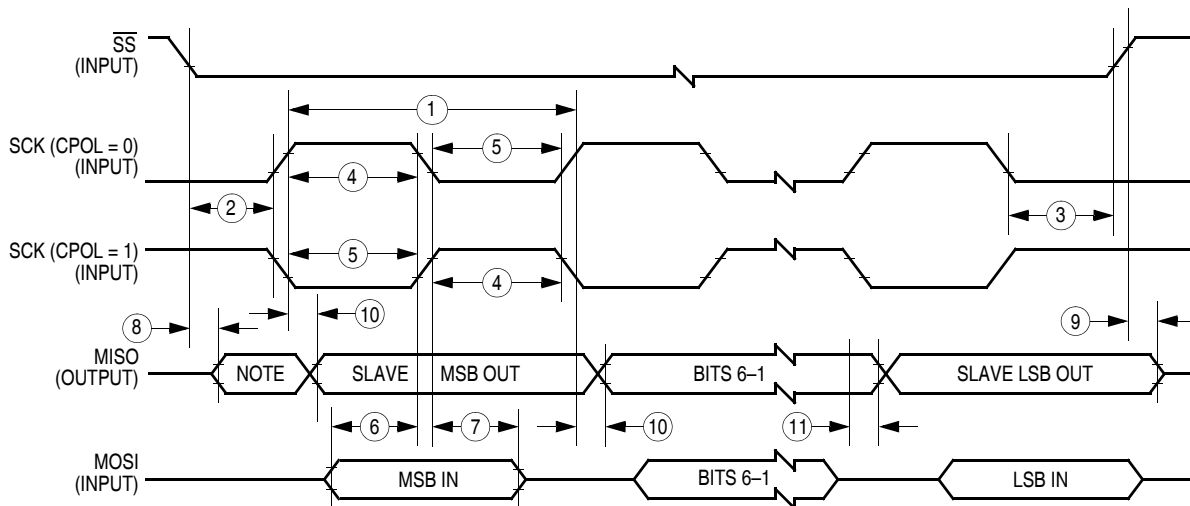
**b) SPI Master Timing (CPHA = 1)**

**Figure 21-1. SPI Master Timing**



NOTE: Not defined but normally MSB of character just received.

### a) SPI Slave Timing (CPHA = 0)



NOTE: Not defined but normally LSB of character previously transmitted.

### b) SPI Slave Timing (CPHA = 1)

**Figure 21-2. SPI Slave Timing**

## 21.9 Timer Interface Module Characteristics

**Table 21-7. TIM Timing**

Characteristic	Symbol	Min	Max	Unit
Input Capture Pulse Width	$t_{TIH}, t_{TIL}$	125	—	ns
Input Clock Pulse Width	$t_{TCH}, t_{TCL}$	$(1/f_{OP}) + 5$	—	ns

## 21.10 Clock Generation Module Electrical Characteristics

**Table 21-8. CGM Component Specifications**

Characteristic	Symbol	Min	Typ	Max	Notes
Crystal Load Capacitance	$C_L$	—	—	—	Consult Crystal Manufacturing Data
Crystal Fixed Capacitance	$C_1$	—	$2 \cdot C_L$	—	Consult Crystal Manufacturing Data
Crystal Tuning Capacitance	$C_2$	—	$2 \cdot C_L$	—	Consult Crystal Manufacturing Data
Feedback Bias Resistor	$R_B$	—	22 M $\Omega$	—	
Series Resistor	$R_S$	0	330 k $\Omega$	1 M $\Omega$	Not Required
Filter Capacitor	$C_F$	—	$C_{FACT}^*$ ( $V_{DDA}/f_{XCLK}$ )	—	
Bypass Capacitor	$C_{BYP}$	—	0.1 $\mu$ F	—	$C_{BYP}$ must provide low AC impedance from $f = f_{XCLK}/100$ to $100 \cdot f_{VCLK}$ , so series resistance must be considered.

**Table 21-9. CGM Operating Conditions**

Characteristic	Symbol	Min	Typ	Max
Crystal Reference Frequency	$f_{XCLK}$	1MHz	—	8 MHz
Range Nominal Multiplier	$f_{NOM}$	—	4.9152 MHz	—
VCO Center-of-Range Frequency	$f_{VRS}$	4.9152 MHz	—	32.8 MHz
VCO Frequency Multiplier	N	1	—	15
VCO Center of Range Multiplier	L	1	—	15
VCO Operating Frequency	$f_{VCLK}$	$f_{VRSMIN}$	—	$f_{VRSMAX}$

**Table 21-10. CGM Acquisition/Lock Time Specifications**

Description	Symbol	Min	Typ	Max	Notes
Filter Capacitor Multiply Factor	$C_{FACT}$	—	0.0154	—	F/sV
Acquisition Mode Time Factor	$K_{ACQ}$	—	0.1135	—	V
Tracking Mode Time Factor	$K_{TRK}$	—	0.0174	—	V
Manual Mode Time to Stable	$t_{ACQ}$	—	$(8 \cdot V_{DDA}) / (f_{X\ CLK} \cdot K_{ACQ})$	—	If $C_F$ chosen correctly.
Manual Stable to Lock Time	$t_{AL}$	—	$(4 \cdot V_{DDA}) / (f_{X\ CLK} \cdot K_{TRK})$	—	If $C_F$ chosen correctly.
Manual Acquisition Time	$t_{LOCK}$	—	$t_{ACQ} + t_{AL}$	—	
Tracking Mode Entry Frequency Tolerance	$\Delta_{TRK}$	0	—	$\pm 3.6\%$	
Acquisition Mode Entry Frequency Tolerance	$\Delta_{ACQ}$	$\pm 6.3\%$	—	$\pm 7.2\%$	
LOCK Entry Frequency Tolerance	$\Delta_{LOCK}$	0	—	$\pm 0.9\%$	
LOCK Exit Frequency Tolerance	$\Delta_{UNL}$	$\pm 0.9\%$	—	$\pm 1.8\%$	
Reference Cycles per Acquisition Mode Measurement	$n_{ACQ}$	—	32	—	
Reference Cycles per Tracking Mode Measurement	$n_{TRK}$	—	128	—	
Automatic Mode Time to Stable	$t_{ACQ}$	$n_{ACQ} / f_{XCLK}$	$(8 \cdot V_{DDA}) / (f_{X\ CLK} \cdot K_{ACQ})$	—	If $C_F$ chosen correctly.
Automatic Stable to Lock Time	$t_{AL}$	$n_{TRK} / f_{XCLK}$	$(4 \cdot V_{DDA}) / (f_{X\ CLK} \cdot K_{TRK})$	—	If $C_F$ chosen correctly.
Automatic Lock Time	$t_{LOCK}$	—	$t_{ACQ} + t_{AL}$	—	
PLL Jitter (Deviation of Average Bus Frequency Over 2 ms)	$f_J$	0	—	$\pm (f_{CRYS})$ $\cdot (0.025\%)$ $\cdot (N/4)$	N = VCO freq. mult. (GBNT)



## 21.11 Analog-to-Digital Converter (ADC) Characteristics

**Table 21-11. ADC Characteristics**

Characteristic	Symbol	Min	Max	Unit	Notes
Supply Voltage	$V_{DDAD}$	4.5	5.5	V	$V_{DDAD}$ should be tied to the same potential as $V_{DD}$ via separate traces.
Input Voltages	$V_{ADIN}$	0	$V_{DDAD}$	V	$V_{ADIN} \leq V_{DDAD}$
Resolution	$B_{AD}$	8	8	Bits	
Absolute Accuracy	$A_{AD}$	—	1	LSB	Includes Quantization
ADC Internal Clock	$f_{ADIC}$	500 k	1.048 M	Hz	$t_{AIC} = 1/f_{ADIC}$
Conversion Range	$R_{AD}$	$V_{SSAD}$	$V_{DDAD}$	V	
Power-Up Time	$t_{ADPU}$	16		$t_{AIC}$ Cycles	
Conversion Time	$t_{ADC}$	16	17	$t_{AIC}$ Cycles	
Sample Time	$t_{ADS}$	5	—	$t_{AIC}$ Cycles	
Monotocity	$M_{AD}$	Guaranteed			
Zero Input Reading	$Z_{ADI}$	00	—	Hex	$V_{ADIN} = V_{SSAD}$
Full-scale Reading	$F_{ADI}$	—	FF	Hex	$V_{ADIN} = V_{DDAD}$
Input Capacitance	$C_{ADI}$	—	30	pF	Not tested

## 21.12 Memory Characteristics

**Table 21-12. Memory Characteristics**

Characteristic	Symbol	Min	Typ	Max	Unit
EPROM Programming Voltage	$V_{EPGM}$	12.5	13.0	13.5	V
EPROM Data Retention Time	$t_{EDR}$	—	10.0	—	Years
EPROM Programming Time	$t_{EPGM}$	—	1	—	ms/Byte
RAM Data Retention Voltage	$V_{RDR}$	0.7	—	—	V



## Section 22. Mechanical Specifications

### 22.1 Contents

22.2	Introduction . . . . .	379
22.3	Plastic Quad Flat Pack (QFP) . . . . .	380

### 22.2 Introduction

This section gives the dimensions for the 64-lead plastic quad flat pack (QFP).

# Mechanical Specifications

## 22.3 Plastic Quad Flat Pack (QFP)

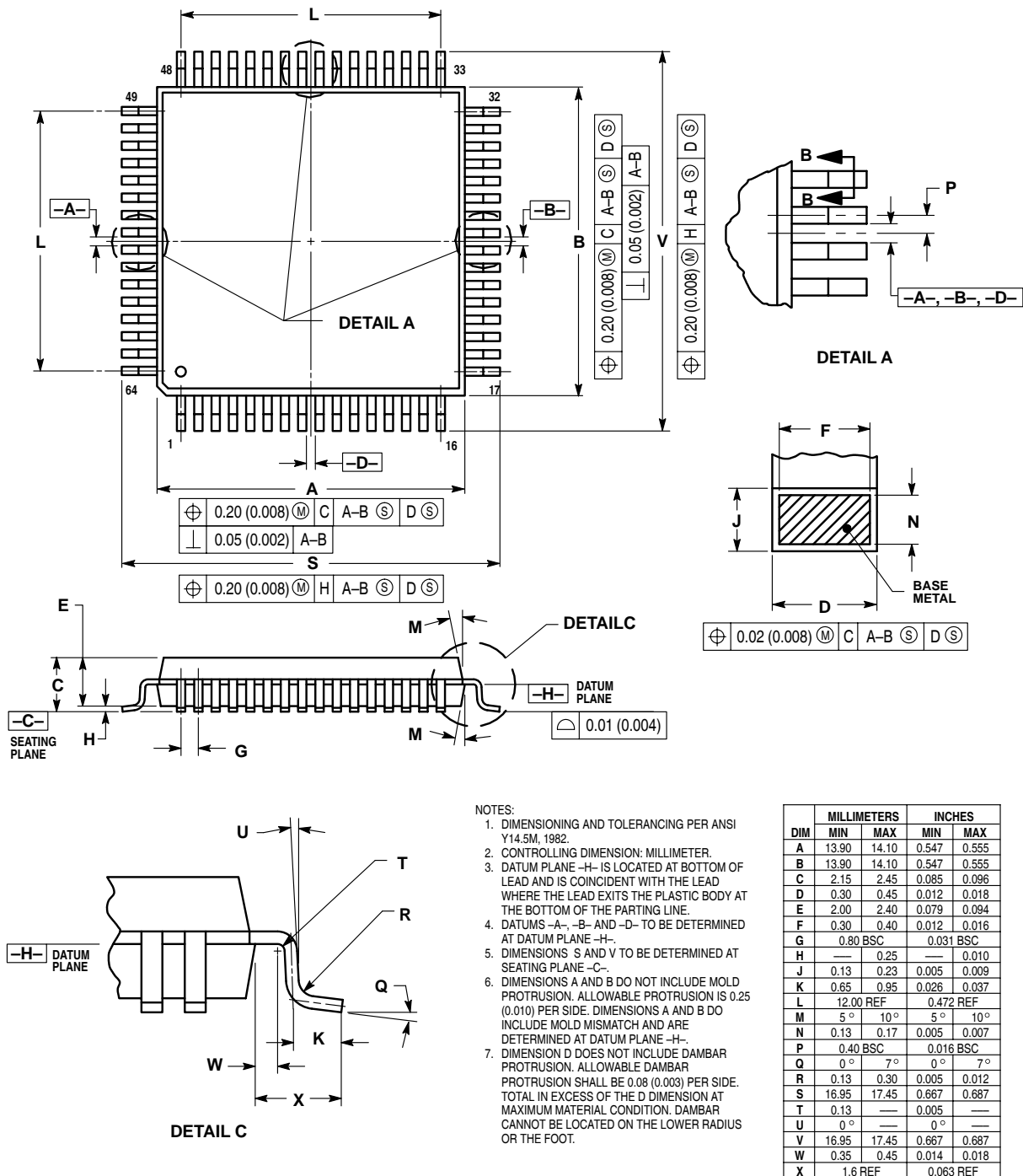


Figure 22-1. MC68HC708MP16FU (Case #840B-01)

## Section 23. Ordering Information

### 23.1 Contents

23.2	Introduction .....	381
23.3	MC Order Numbers .....	381

### 23.2 Introduction

This section contains ordering information.

### 23.3 MC Order Numbers

**Table 23-1. MC Order Numbers**

MC Order Number	Operating Temperature Range
MC68HC708MP16CFU <sup>(1)</sup>	–40 °C to 85 °C
MC68HC708MP16VFU	–40 °C to 105 °C

1. FU = Plastic quad flat pack

## Ordering Information

## Glossary

**A** — See accumulator (A).

**accumulator (A)** — An 8-bit general-purpose register in the CPU08. The CPU08 uses the accumulator to hold operands and results of arithmetic and logic operations.

**acquisition mode** — A mode of PLL operation during startup before the PLL locks on a frequency. Also see tracking mode.

**address bus** — The set of wires that the CPU or DMA uses to read and write memory locations.

**addressing mode** — The way that the CPU determines the operand address for an instruction. The M68HC08 CPU has 16 addressing modes.

**ALU** — See arithmetic logic unit (ALU).

**arithmetic logic unit (ALU)** — The portion of the CPU that contains the logic circuitry to perform arithmetic, logic, and manipulation operations on operands.

**asynchronous** — Refers to logic circuits and operations that are not synchronized by a common reference signal.

**baud rate** — The total number of bits transmitted per unit of time.

**BCD** — See binary-coded decimal (BCD).

**binary** — Relating to the base 2 number system.

**binary number system** — The base 2 number system, having two digits, 0 and 1. Binary arithmetic is convenient in digital circuit design because digital circuits have two permissible voltage levels, low and high. The binary digits 0 and 1 can be interpreted to correspond to the two digital voltage levels.

**binary-coded decimal (BCD)** — A notation that uses 4-bit binary numbers to represent the 10 decimal digits and that retains the same positional structure of a decimal number. For example,

$$234 \text{ (decimal)} = 0010 \ 0011 \ 0100 \text{ (BCD)}$$

**bit** — A binary digit. A bit has a value of either logic 0 or logic 1.

**branch instruction** — An instruction that causes the CPU to continue processing at a memory location other than the next sequential address.

**break module** — A module in the M68HC08 Family. The break module allows software to halt program execution at a programmable point in order to enter a background routine.

**breakpoint** — A number written into the break address registers of the break module. When a number appears on the internal address bus that is the same as the number in the break address registers, the CPU executes the software interrupt instruction (SWI).

**break interrupt** — A software interrupt caused by the appearance on the internal address bus of the same value that is written in the break address registers.

**bus** — A set of wires that transfers logic signals.

**bus clocks** — There are two bus clocks, IT12 and IT23. These clocks are generated by the CGM and distributed throughout the MCU by the SIM. The frequency of the bus clocks, or operating frequency, is  $f_{OP}$ . While the frequency of these two clocks is the same, the phase is different.

**byte** — A set of eight bits.

**C** — The carry/borrow bit in the condition code register. The CPU08 sets the carry/borrow bit when an addition operation produces a carry out of bit 7 of the accumulator or when a subtraction operation requires a borrow. Some logical operations and data manipulation instructions also clear or set the carry/borrow bit (as in bit test and branch instructions and shifts and rotates).

**CCR** — See condition code register.



**central processor unit (CPU)** — The primary functioning unit of any computer system. The CPU controls the execution of instructions.

**CGM** — See clock generator module (CGM).

**clear** — To change a bit from logic 1 to logic 0; the opposite of set.

**clock** — A square wave signal used to synchronize events in a computer.

**clock generator module (CGM)** — A module in the M68HC08 Family. The CGM generates a base clock signal from which the system clocks are derived. The CGM may include a crystal oscillator circuit and/or phase-locked loop (PLL) circuit.

**comparator** — A device that compares the magnitude of two inputs. A digital comparator defines the equality or relative differences between two binary numbers.

**computer operating properly module (COP)** — A counter module in the M68HC08 Family that resets the MCU if allowed to overflow.

**condition code register (CCR)** — An 8-bit register in the CPU08 that contains the interrupt mask bit and five bits that indicate the results of the instruction just executed.

**control bit** — One bit of a register manipulated by software to control the operation of the module.

**control unit** — One of two major units of the CPU. The control unit contains logic functions that synchronize the machine and direct various operations. The control unit decodes instructions and generates the internal control signals that perform the requested operations. The outputs of the control unit drive the execution unit, which contains the arithmetic logic unit (ALU), CPU registers, and bus interface.

**COP** — See computer operating properly module (COP).

**counter clock** — The input clock to the TIM counter. This clock is an output of the prescaler sub-module. The frequency of the counter clock is  $f_{TCNT}$ , and the period is  $t_{TCNT}$ .

**CPU** — See central processor unit (CPU).

**CPU08** — The central processor unit of the M68HC08 Family.

**CPU cycles** — A CPU clock cycle is one period of the internal bus-rate clock,  $f_{OP}$ , normally derived by dividing a crystal oscillator source by two or more so the high and low times will be equal. The length of time required to execute an instruction is measured in CPU clock cycles.

**CPU registers** — Memory locations that are wired directly into the CPU logic instead of being part of the addressable memory map. The CPU always has direct access to the information in these registers. The CPU registers in an M68HC08 are:

- A (8-bit accumulator)
- H:X (16-bit index register)
- SP (16-bit stack pointer)
- PC (16-bit program counter)
- CCR (condition code register containing the V, H, I, N, Z, and C bits)

**CSIC** — customer-specified integrated circuit

**cycle time** — The period of the operating frequency:  $t_{CYC} = 1/f_{OP}$ .

**decimal number system** — Base 10 numbering system that uses the digits zero through nine.

**direct memory access module (DMA)** — A M68HC08 Family module that can perform data transfers between any two CPU-addressable locations without CPU intervention. For transmitting or receiving blocks of data to or from peripherals, DMA transfers are faster and more code-efficient than CPU interrupts.

**DMA** — See direct memory access module (DMA).

**DMA service request** — A signal from a peripheral to the DMA module that enables the DMA module to transfer data.

**duty cycle** — A ratio of the amount of time the signal is on versus the time it is off. Duty cycle is usually represented by a percentage.

**EEPROM** — Electrically erasable, programmable, read-only memory. A non-volatile type of memory that can be electrically reprogrammed.

**EPROM** — Erasable, programmable, read-only memory. A non-volatile type of memory that can be erased by exposure to an ultraviolet light source and then reprogrammed.

**exception** — An event such as an interrupt or a reset that stops the sequential execution of the instructions in the main program.

**external interrupt module (IRQ)** — A module in the M68HC08 Family with both dedicated external interrupt pins and port pins that can be enabled as interrupt pins.

**fetch** — To copy data from a memory location into the accumulator.

**firmware** — Instructions and data programmed into non-volatile memory.

**free-running counter** — A device that counts from zero to a predetermined number, then rolls over to zero and begins counting again.

**full-duplex transmission** — Communication on a channel in which data can be sent and received simultaneously.

**H** — The upper byte of the 16-bit index register (H:X) in the CPU08.

**H** — The half-carry bit in the condition code register of the CPU08. This bit indicates a carry from the low-order four bits of the accumulator value to the high-order four bits. The half-carry bit is required for binary-coded decimal arithmetic operations. The decimal adjust accumulator (DAA) instruction uses the state of the H and C bits to determine the appropriate correction factor.

**hexadecimal** — Base 16 numbering system that uses the digits 0 through 9 and the letters A through F.

**high byte** — The most significant eight bits of a word.

**illegal address** — An address not within the memory map

**illegal opcode** — A non-existent opcode.

**I** — The interrupt mask bit in the condition code register of the CPU08. When I is set, all interrupts are disabled.

**index register (H:X)** — A 16-bit register in the CPU08. The upper byte of H:X is called H. The lower byte is called X. In the indexed addressing modes, the CPU uses the contents of H:X to determine the effective address of the operand. H:X can also serve as a temporary data storage location.

**input/output (I/O)** — Input/output interfaces between a computer system and the external world. A CPU reads an input to sense the level of an external signal and writes to an output to change the level on an external signal.

**instructions** — Operations that a CPU can perform. Instructions are expressed by programmers as assembly language mnemonics. A CPU interprets an opcode and its associated operand(s) and instruction.

**interrupt** — A temporary break in the sequential execution of a program to respond to signals from peripheral devices by executing a subroutine.

**interrupt request** — A signal from a peripheral to the CPU intended to cause the CPU to execute a subroutine.

**I/O** — See input/output (I/O).

**IRQ** — See external interrupt module (IRQ).

**jitter** — Short-term signal instability.

**latch** — A circuit that retains the voltage level (logic 1 or logic 0) written to it for as long as power is applied to the circuit.

**latency** — The time lag between instruction completion and data movement.

**least significant bit (LSB)** — The rightmost digit of a binary number.

**logic 1** — A voltage level approximately equal to the input power voltage ( $V_{DD}$ ).

**logic 0** — A voltage level approximately equal to the ground voltage ( $V_{SS}$ ).

**low byte** — The least significant eight bits of a word.

**low voltage inhibit module (LVI)** — A module in the M68HC08 Family that monitors power supply voltage.

**LVI** — See low voltage inhibit module (LVI).

**M68HC08** — A Freescale family of 8-bit MCUs.

**mark/space** — The logic 1/logic 0 convention used in formatting data in serial communication.

**mask** — 1. A logic circuit that forces a bit or group of bits to a desired state. 2. A photomask used in integrated circuit fabrication to transfer an image onto silicon.

**mask option** — An optional microcontroller feature that the customer chooses to enable or disable.

**mask option register (MOR)** — An EPROM location containing bits that enable or disable certain MCU features.

**MCU** — Microcontroller unit. See microcontroller.

**memory location** — Each M68HC08 memory location holds one byte of data and has a unique address. To store information in a memory location, the CPU places the address of the location on the address bus, the data information on the data bus, and asserts the write signal. To read information from a memory location, the CPU places the address of the location on the address bus and asserts the read signal. In response to the read signal, the selected memory location places its data onto the data bus.

**memory map** — A pictorial representation of all memory locations in a computer system.

**microcontroller** — Microcontroller unit (MCU). A complete computer system, including a CPU, memory, a clock oscillator, and input/output (I/O) on a single integrated circuit.

**modulo counter** — A counter that can be programmed to count to any number from zero to its maximum possible modulus.

**monitor ROM** — A section of ROM that can execute commands from a host computer for testing purposes.

**MOR** — See mask option register (MOR).

**most significant bit (MSB)** — The leftmost digit of a binary number.

**multiplexer** — A device that can select one of a number of inputs and pass the logic level of that input on to the output.

**N** — The negative bit in the condition code register of the CPU08. The CPU sets the negative bit when an arithmetic operation, logical operation, or data manipulation produces a negative result.

**nibble** — A set of four bits (half of a byte).

**object code** — The output from an assembler or compiler that is itself executable machine code, or is suitable for processing to produce executable machine code.

**opcode** — A binary code that instructs the CPU to perform an operation.

**open-drain** — An output that has no pullup transistor. An external pullup device can be connected to the power supply to provide the logic 1 output voltage.

**operand** — Data on which an operation is performed. Usually a statement consists of an operator and an operand. For example, the operator may be an add instruction, and the operand may be the quantity to be added.

**oscillator** — A circuit that produces a constant frequency square wave that is used by the computer as a timing and sequencing reference.

**OTPROM** — One-time programmable read-only memory. A non-volatile type of memory that cannot be reprogrammed.

**overflow** — A quantity that is too large to be contained in one byte or one word.

**page zero** — The first 256 bytes of memory (addresses \$0000–\$00FF).

**parity** — An error-checking scheme that counts the number of logic 1s in each byte transmitted. In a system that uses odd parity, every byte is expected to have an odd number of logic 1s. In an even parity system, every byte should have an even number of logic 1s. In the transmitter, a parity generator appends an extra bit to each byte to make the number of logic 1s odd for odd parity or even for even parity. A parity checker in the receiver counts the number of logic 1s in each byte. The parity checker generates an error signal if it finds a byte with an incorrect number of logic 1s.

**PC** — See program counter (PC).

**peripheral** — A circuit not under direct CPU control.

**phase-locked loop (PLL)** — An oscillator circuit in which the frequency of the oscillator is synchronized to a reference signal.

**PLL** — See phase-locked loop (PLL).

**pointer** — Pointer register. An index register is sometimes called a pointer register because its contents are used in the calculation of the address of an operand, and therefore points to the operand.

**polarity** — The two opposite logic levels, logic 1 and logic 0, which correspond to two different voltage levels,  $V_{DD}$  and  $V_{SS}$ .

**polling** — Periodically reading a status bit to monitor the condition of a peripheral device.

**port** — A set of wires for communicating with off-chip devices.

**prescaler** — A circuit that generates an output signal related to the input signal by a fractional scale factor such as 1/2, 1/8, 1/10, etc.

**program** — A set of computer instructions that causes a computer to perform a desired operation or operations.

**program counter (PC)** — A 16-bit register in the CPU08. The PC register holds the address of the next instruction or operand that the CPU will use.

**pull** — An instruction that copies into the accumulator the contents of a stack RAM location. The stack RAM address is in the stack pointer.

**pullup** — A transistor in the output of a logic gate that connects the output to the logic 1 voltage of the power supply.

**pulse-width** — The amount of time a signal is on as opposed to being in its off state.

**pulse-width modulation (PWM)** — Controlled variation (modulation) of the pulse width of a signal with a constant frequency.

**push** — An instruction that copies the contents of the accumulator to the stack RAM. The stack RAM address is in the stack pointer.

**PWM period** — The time required for one complete cycle of a PWM waveform.

**RAM** — Random access memory. All RAM locations can be read or written by the CPU. The contents of a RAM memory location remain valid until the CPU writes a different value or until power is turned off.

**RC circuit** — A circuit consisting of capacitors and resistors having a defined time constant.

**read** — To copy the contents of a memory location to the accumulator.

**register** — A circuit that stores a group of bits.

**reserved memory location** — A memory location that is used only in special factory-test modes. Writing to a reserved location has no effect. Reading a reserved location returns an unpredictable value.

**reset** — To force a device to a known condition.

**ROM** — Read-only memory. A type of memory that can be read but cannot be changed (written). The contents of ROM must be specified before manufacturing the MCU.

**SCI** — See serial communication interface module (SCI).

**serial** — Pertaining to sequential transmission over a single line.

**serial communication interface module (SCI)** — A module in the M68HC08 Family that supports asynchronous communication.

**serial peripheral interface module (SPI)** — A module in the M68HC08 Family that supports synchronous communication.



**set** — To change a bit from logic 0 to logic 1; opposite of clear.

**shift register** — A chain of circuits that can retain the logic levels (logic 1 or logic 0) written to them and that can shift the logic levels to the right or left through adjacent circuits in the chain.

**signed** — A binary number notation that accommodates both positive and negative numbers. The most significant bit is used to indicate whether the number is positive or negative, normally logic 0 for positive and logic 1 for negative. The other seven bits indicate the magnitude of the number.

**SIM** — See system integration module (SIM).

**software** — Instructions and data that control the operation of a microcontroller.

**software interrupt (SWI)** — An instruction that causes an interrupt and its associated vector fetch.

**SPI** — See serial peripheral interface module (SPI).

**stack** — A portion of RAM reserved for storage of CPU register contents and subroutine return addresses.

**stack pointer (SP)** — A 16-bit register in the CPU08 containing the address of the next available storage location on the stack.

**start bit** — A bit that signals the beginning of an asynchronous serial transmission.

**status bit** — A register bit that indicates the condition of a device.

**stop bit** — A bit that signals the end of an asynchronous serial transmission.

**subroutine** — A sequence of instructions to be used more than once in the course of a program. The last instruction in a subroutine is a return from subroutine (RTS) instruction. At each place in the main program where the subroutine instructions are needed, a jump or branch to subroutine (JSR or BSR) instruction is used to call the subroutine. The CPU leaves the flow of the main program to execute the instructions in the subroutine. When the RTS instruction is executed, the CPU returns to the main program where it left off.

**synchronous** — Refers to logic circuits and operations that are synchronized by a common reference signal.

**system integration module (SIM)** — One of a number of modules that handle a variety of control functions in the modular M68HC08 Family. The SIM controls mode of operation, resets and interrupts, and system clock distribution.

**TIM** — See timer interface module (TIM).

**timer interface module (TIM)** — A module used to relate events in a system to a point in time.

**timer** — A module used to relate events in a system to a point in time.

**toggle** — To change the state of an output from a logic 0 to a logic 1 or from a logic 1 to a logic 0.

**tracking mode** — Mode of low-jitter PLL operation during which the PLL is locked on a frequency. Also see acquisition mode.

**two's complement** — A means of performing binary subtraction using addition techniques. The most significant bit of a two's complement number indicates the sign of the number (1 indicates negative). The two's complement negative of a number is obtained by inverting each bit in the number and then adding 1 to the result.

**unbuffered** — Utilizes only one register for data; new data overwrites current data.

**unimplemented memory location** — A memory location that is not used. Writing to an unimplemented location has no effect. Reading an unimplemented location returns an unpredictable value. Executing an opcode at an unimplemented location causes an illegal address reset.

**V** — The overflow bit in the condition code register of the CPU08. The CPU08 sets the V bit when a two's complement overflow occurs. The signed branch instructions BGT, BGE, BLE, and BLT use the overflow bit.

**variable** — A value that changes during the course of program execution.

**VCO** — See voltage-controlled oscillator.

**vector** — A memory location that contains the address of the beginning of a subroutine written to service an interrupt or reset.

**voltage-controlled oscillator (VCO)** — A circuit that produces an oscillating output signal of a frequency that is controlled by a dc voltage applied to a control input.

**waveform** — A graphical representation in which the amplitude of a wave is plotted against time.

**wired-OR** — Connection of circuit outputs so that if any output is high, the connection point is high.

**word** — A set of two bytes (16 bits).

**write** — The transfer of a byte of data from the CPU to a memory location.

**X** — The lower byte of the index register (H:X) in the CPU08.

**Z** — The zero bit in the condition code register of the CPU08. The CPU08 sets the zero bit when an arithmetic operation, logical operation, or data manipulation produces a result of \$00.





## **How to Reach Us:**

### **Home Page:**

[www.freescale.com](http://www.freescale.com)

### **E-mail:**

[support@freescale.com](mailto:support@freescale.com)

### **USA/Europe or Locations Not Listed:**

Freescale Semiconductor  
Technical Information Center, CH370  
1300 N. Alma School Road  
Chandler, Arizona 85224  
+1-800-521-6274 or +1-480-768-2130  
[support@freescale.com](mailto:support@freescale.com)

### **Europe, Middle East, and Africa:**

Freescale Halbleiter Deutschland GmbH  
Technical Information Center  
Schatzbogen 7  
81829 Muenchen, Germany  
+44 1296 380 456 (English)  
+46 8 52200080 (English)  
+49 89 92103 559 (German)  
+33 1 69 35 48 48 (French)  
[support@freescale.com](mailto:support@freescale.com)

### **Japan:**

Freescale Semiconductor Japan Ltd.  
Headquarters  
ARCO Tower 15F  
1-8-1, Shimo-Meguro, Meguro-ku,  
Tokyo 153-0064  
Japan  
0120 191014 or +81 3 5437 9125  
[support.japan@freescale.com](mailto:support.japan@freescale.com)

### **Asia/Pacific:**

Freescale Semiconductor Hong Kong Ltd.  
Technical Information Center  
2 Dai King Street  
Tai Po Industrial Estate  
Tai Po, N.T., Hong Kong  
+800 2666 8080  
[support.asia@freescale.com](mailto:support.asia@freescale.com)

### **For Literature Requests Only:**

Freescale Semiconductor Literature Distribution Center  
P.O. Box 5405  
Denver, Colorado 80217  
1-800-441-2447 or 303-675-2140  
Fax: 303-675-2150  
[LDCForFreescaleSemiconductor@hibbertgroup.com](mailto:LDCForFreescaleSemiconductor@hibbertgroup.com)

RoHS-compliant and/or Pb-free versions of Freescale products have the functionality and electrical characteristics of their non-RoHS-compliant and/or non-Pb-free counterparts. For further information, see <http://www.freescale.com> or contact your Freescale sales representative.

For information on Freescale's Environmental Products program, go to <http://www.freescale.com/epp>.

Information in this document is provided solely to enable system and software implementers to use Freescale Semiconductor products. There are no express or implied copyright licenses granted hereunder to design or fabricate any integrated circuits or integrated circuits based on the information in this document.

Freescale Semiconductor reserves the right to make changes without further notice to any products herein. Freescale Semiconductor makes no warranty, representation or guarantee regarding the suitability of its products for any particular purpose, nor does Freescale Semiconductor assume any liability arising out of the application or use of any product or circuit, and specifically disclaims any and all liability, including without limitation consequential or incidental damages. "Typical" parameters that may be provided in Freescale Semiconductor data sheets and/or specifications can and do vary in different applications and actual performance may vary over time. All operating parameters, including "Typicals", must be validated for each customer application by customer's technical experts. Freescale Semiconductor does not convey any license under its patent rights nor the rights of others. Freescale Semiconductor products are not designed, intended, or authorized for use as components in systems intended for surgical implant into the body, or other applications intended to support or sustain life, or for any other application in which the failure of the Freescale Semiconductor product could create a situation where personal injury or death may occur. Should Buyer purchase or use Freescale Semiconductor products for any such unintended or unauthorized application, Buyer shall indemnify and hold Freescale Semiconductor and its officers, employees, subsidiaries, affiliates, and distributors harmless against all claims, costs, damages, and expenses, and reasonable attorney fees arising out of, directly or indirectly, any claim of personal injury or death associated with such unintended or unauthorized use, even if such claim alleges that Freescale Semiconductor was negligent regarding the design or manufacture of the part.

Freescale™ and the Freescale logo are trademarks of Freescale Semiconductor, Inc. All other product or service names are the property of their respective owners. The ARM POWERED logo is a registered trademark of ARM Limited. ARM7TDMI-S is a trademark of ARM Limited. Java and all other Java-based marks are trademarks or registered trademarks of Sun Microsystems, Inc. in the U.S. and other countries. The Bluetooth trademarks are owned by their proprietor and used by Freescale Semiconductor, Inc. under license.

© Freescale Semiconductor, Inc. 2005. All rights reserved.

Rev. 3.1

MC68HC708MP16/D

July 28, 2005

