

StorageTek®

**9914 STREAMER
SERVICING MANUAL**

95 121797

9914 STREAMER

SERVICING MANUAL

Document Ref. 95 121797

Issue 1 + Amdt 8

SAFETY MEASURES

1. This instruction manual contains certain ---CAUTION---AND ---WARNING--- notices which **MUST** be followed by the user to ensure **SAFE** operation and to retain the equipment in a **SAFE** condition.
2. Any adjustment, maintenance and repair of the opened apparatus under voltage shall be carried out only by a skilled person who is **AWARE OF THE HAZARD INVOLVED.**

Bescheinigung des Herstellers

Hiermit wird bescheinigt, dass die Magnetbandeinheit Modell 9914 in Übereinstimmung mit den Bestimmungen der AmtsblVfg 1046/1984 funktionsfähig ist.

Der Deutschen Bundespost wurde das Inverkehrbringen dieses Gerätes angezeigt und die Berechtigung zur Überprüfung der Serie auf Einhaltung der Bestimmungen eingeräumt.

Storage Technology Manufacturing Ltd.

English translation of manufacturer's declaration in German:

It is hereby certified that the Magnetic Tape Unit Model 9914 in compliance with the regulations of AmtsblVfg 1046/1984 is radio interference suppressed.

The German Post Office has been notified that this equipment has been introduced into the market and is granted the right to type-test the equipment for compliance with the regulations.

Storage Technology Manufacturing Ltd.

Le présent appareil numérique n'émet pas de bruits radioélectriques dépassant les limites applicables aux appareils numériques de la class A prescrites dans le Règlement sur le brouillage radioélectrique édicté par le ministère des Communications du Canada.

English translation of manufacturer's declaration in French:

This digital apparatus does not exceed the class A limits for radio noise emissions from digital apparatus set out in the Radio Interference Regulations of the Canadian Department of Communications.

SPARES and SERVICE CENTRES

USA

Storage Technology Corporation
2270 South 88th Street
Louisville
Colorado 80028-4393
USA

Tel: 303 673 7278
Fax: 303 673 5019
Telex: 3720475
3720476

UK

Storage Technology Corporation
81 High Street
Esher
Surrey
KT10 9QA
England

Tel: 0372 468188
Fax: 0372 463162
Telex: none

GERMANY

Storage Technology Corporation
Bernner Strasse 35
D-6000 Frankfurt 56
West Germany

Tel: 069/5001 295
Fax: 069/5001 293
Telex: 416401

FRANCE

Storage Technology Corporation
Z.I. - 41, rue Fourny
B.P.73 - 78530 BUC
France

Tel: 30 84 36 81
Fax: 39 56 01 83
Telex: 695651

CONTENTS (MAJOR HEADINGS)

	<i>Page</i>
CHAPTER 1 9914 OVERVIEW	
1.1 SCOPE OF MANUAL	1
1.2 9914 FEATURES	2
1.3 SHORT FORM SPECIFICATION	6
1.4 STREAMING	7
1.5 I.T. MAINS SYSTEMS	9
1.6 RFI COMPLIANCE	9
1.7 INTERFACE CABLES	9
1.8 ESD PRECAUTIONS	9
1.9 ASSOCIATED DOCUMENTS	9
 CHAPTER 2 PRINTED CIRCUIT BOARD DESCRIPTIONS	
2.1 SCOPE OF CHAPTER 2	1
2.2 SERVO CONTROL BOARD CIRCUIT DESCRIPTION	2
2.3 DATA CONTROL BOARD CIRCUIT DESCRIPTION	11
2.4 ANALOGUE DATA PATHS BOARD DESCRIPTION	14
2.5 DIGITAL DATA PATHS BOARD DESCRIPTION	21
2.6 PRE-AMPLIFIER BOARD DESCRIPTION	24
2.7 POWER SUPPLY BOARD DESCRIPTION	25
2.8 SCSI INTERFACE BOARD DESCRIPTION	29
 CHAPTER 3 FAULT FINDING AND CALIBRATION	
3.1 SCOPE OF CHAPTER 3	1
3.2 STARTUP	1
3.3 DIAGNOSTIC PROGRAM ERROR CODES	13
3.4 COMMON ERROR CODES	19
3.5 DIAGNOSTIC PROGRAM DESCRIPTIONS	21
3.6 ADDITIONAL FAULT-FINDING IDEAS	41
3.7 MANUAL TAPE LOADING	47
3.8 AZIMUTH CHECKING/SETTING	47
3.9 TAPE TENSION CHECKING/SETTING	48
3.10 TAPE SPEED CHECKING	48
3.11 RE-CALIBRATION	49
3.12 CONFIGURABLE OPTIONS	50
3.13 FULL STATUS BYTES	71
3.14 CONDENSED STATUS BYTES	80

CHAPTER 4 SUB-ASSEMBLIES

4.0	SCOPE OF CHAPTER 4	1
4.1	SERVICING EQUIPMENT AND PROCEDURES	2
4.2	MAINS TRANSFORMER AND SWITCH	4
4.3	POWER SUPPLY BOARD	7
4.4	SERVO CONTROL BOARD	9
4.5	CONTROLS AND INDICATORS	10
4.6	SUPPLY HUB	12
4.7	REEL MOTORS	18
4.8	TAPE PATH ASSEMBLY	19
4.9	TAPE CLEANER	20
4.10	TAPE PATH ROLLERS	21
4.11	TENSION ARM ASSEMBLY	22
4.12	DATA CONTROL BOARD	23
4.13	ANALOGUE DATA PATHS BOARD	24
4.14	DIGITAL DATA PATHS BOARD	25
4.15	SCSI BOARD	26
4.16	COOLING FAN	27

CHAPTER 5 SUB-ASSEMBLY LOCATIONS AND SPARES LISTS

5.1	SCOPE OF CHAPTER 5	1
5.2	SUB-ASSEMBLY LOCATIONS	1
5.3	AVAILABLE SPARES	8

APPENDIX A DATA ENCODING

A.1	NRZ ENCODING	1
A.2	PE/DPE ENCODING	2
A.3	GCR ENCODING	3

APPENDIX B ADP MONOSTABLE SETUP

B.1	INTRODUCTION	1
B.2	PROCEDURES	1

FIGURES

<i>Figure</i>	<i>Title</i>	<i>Chapter</i>	<i>Page</i>
.2.6	9914 BLOCK DIAGRAM	Int	xii
1.1	FRONT VIEW OF THE 9914	1	1
1.2.8	9914 DATA PATHS	1	5
1.4	TYPICAL REPOSITION CYCLE	1	8
2.2.2	SERVO CONTROL BLOCK DIAGRAM	2	5
2.4.2(a)	ADP WRITE BLOCK DIAGRAM	2	15
2.4.2(b)	WRITE CURRENT WAVEFORMS	2	16
2.4.3.1(a)	ADP READ BLOCK BLOCK DIAGRAM PE/GCR DENSITIES	2	17
2.4.3.1(b)	PE/GCR READ WAVEFORMS	2	18
2.4.3.1(a)	ADP READ BLOCK BLOCK DIAGRAM NRZ DENSITY	2	19
2.4.3.2(b)	NRZ READ WAVEFORMS	2	19
2.5.3.1	DDP WRITE BLOCK DIAGRAM	2	22
2.5.4.1	DDP READ BLOCK DIAGRAM	2	23
2.7.2	POWER SUPPLY ASSEMBLY	2	26
2.8.1	SCSI CONTROLLER	2	29
3.2(a)	9914 PROCEDURES	3	2
3.2(b)	9914 POWER-ON FLOWCHART	3	3
3.3.1	INTERCONNECTIONS	3	8
3.4.1	ERROR CODE 89	3	19
3.4.2	ERROR CODE 90	3	20
4.2.1	VOLTAGE SELECTION	4	6
4.5.1	CONTROL PANEL BUTTONS AND INDICATORS	4	10
4.6.4.1	SUPPLY HUB HEIGHT SETTING TOOL T6009	4	13
4.6.4.2	SUPPLY HUB TOGGLE (FROM UNDERSIDE)	4	14
4.6.4.3	FITTING THE SUPPLY HUB	4	15
4.6.5.1	LOCATION OF SUPPLY HUB CLAMP	4	16
4.6.5.2	UNIVERSAL HUB REMOVAL TOOL (SET FOR SUPPLY HUB)	4	17
4.7	ORIENTATION OF MOTOR SHAFT	4	18

FIGURES (Cont)

<i>Figure</i>	<i>Title</i>	<i>Chapter</i>	<i>Page</i>
5.2.1	9914 TAPE PATH COMPONENTS	5	2
5.2.2	9914 CIRCUIT BOARD POSITIONS	5	3
5.2.3	9914 BASE TRAY SUB-ASSEMBLIES	5	4
5.2.4	9914 DECK CASTING UNDERSIDE SUB-ASSEMBLIES	5	5
5.2.5	9914 TAPE PATH ASSEMBLY UNDERSIDE	5	6
5.2.6	9914 TAPE PATH ASSEMBLY TOP SIDE	5	7
A.1.1	NRZ TAPE FORMAT	A	1
A.1.2	NRZ FILE MARK FORMAT	A	2
A.2.1	PE TAPE FORMAT	A	2
A.2.2	PE FILE MARK FORMAT	A	3
A.3.1	GCR DATA BLOCK	A	4
A.3.2	GCR PREAMBLE & POSTAMBLE	A	4
A.3.3	GCR TAPE FORMAT, NEAR BOT	A	5
A.3.4	GCR TAPE MARK FORMAT	A	5
B.2.1	ADP MONOSTABLE TEST POINT	B	1
B.2.2	ADP MONOSTABLE WAVEFORM	B	2

TABLES

<i>Table</i>	<i>Title</i>	<i>Chapter</i>	<i>Page</i>
1.4.5	9914 DATA RATES	1	8
3.12	BASIC CONFIGURATION OPTIONS	3	67
3.12(a)	SCSI OPTIONS, PROM 123107, UP TO REV 11	3	68
3.12(b)	SCSI OPTIONS, PROM 123107, REV 11 & 12	3	68
3.12(c)	SCSI OPTIONS, PROM 123107, REV 14	3	69
	& PROM 123996, REV 01		
3.12(d)	SCSI OPTIONS, PROM 123996, REV 02 & 03	3	69
3.12(e)	PERTEC CACHE OPTIONS	3	70
3.14	FULL STATUS BYTES F1 TO F9	3	78
3.14	FULL STATUS BYTES F9 TO F17	3	79
3.14	CONDENSED STATUS BYTES	3	82
4.1.4	RE-CALIBRATIONS AFTER BOARD REPLACEMENT	4	4
4.5.3	CONTROL PANEL CHECKOUT	4	11

SERVICING MANUAL AMENDMENT RECORD SHEET

Amendment	Details	Date
ISSUE 1	Formal release	Nov 1989
Amdt 1	Diagnostic program 45 description corrected. Supply hub fitting instructions corrected, (Figures 4.6.4.3 & 4.6.5.1 amended)	Jan 1990
Amdt 2	Newer SCSI part numbers added. Interconnections (Figure 3.3.1) added. Indications *BOT, **PROC, **DPROC, **PR2, & **SCSI added. Loading message HUBSOL added. Fault code 03 added to programs 28, 29, & 46. Program descriptions 63 -66 & 70 re-worded. Program 73 table added. By-passing data for program 74 added. Revisions made to possible faults (Sections 3.6.2 & 3.6.3). Configuration bytes 13 & 14 updated. New DDP and Data Control board numbers added. Various cosmetic changes.	Apr 1990
Amdt 3	SCSI SW2-7 function corrected. Supply hub setting tool number clarified. Supply hub spares number corrected.	Jul 1990
Amdt 4	Possible faulty FRU's updated. Indications **FAN, **CHUTE, & **Block added. Configuration bytes 06, 13, 14 & 15 updated. Diagnostic program 45 'B' corrected. Diagnostic program 49 indications added. Diagnostic program 80 clarified. Table 4.5.3 corrected. Numerous cosmetic changes.	Feb 1991
Amdt 5	Configuration byte 18 added. Pertec Cache Interface board options added. Diagnostic program 67 described more fully. Diagnostic program 45 BOT/EOT off limits revised. Configuration byte 07, bit 03 corrected. Data Control board replacement described more fully.	Feb 1991
Amdt 6	Publication ref changed from M G0597-A to 95 121797. 'Procedures' and 'Start' flowcharts added to Ch 3. Suspect FRU's updated. Diagnostic error codes grouped together. Indications **BOT, **EOT, RESET, & **TAB added.	Feb 1991
Amdt 7	Suspect FRU's updated. Pertec cache board added. Indications **BIFF, Scm & Dcom added. Indications **ADP1, **ADP2, **DDP1, & **DDP2 added. Diagnostic programs 03, 19, 34 & 35 added. Illustrated parts list added (Chapter 6).	Jul 1991

Amendment Record Sheet (cont)

Amendment	Details	Date
Amdt 8	Illustrated parts list changes: hub sensor fixing screw p/n corrected, power supply fixing screws added, Figure 6.2.18 title corrected, mains switch p/n corrected, tape path cover added.	Nov 1991

This page has no technical content

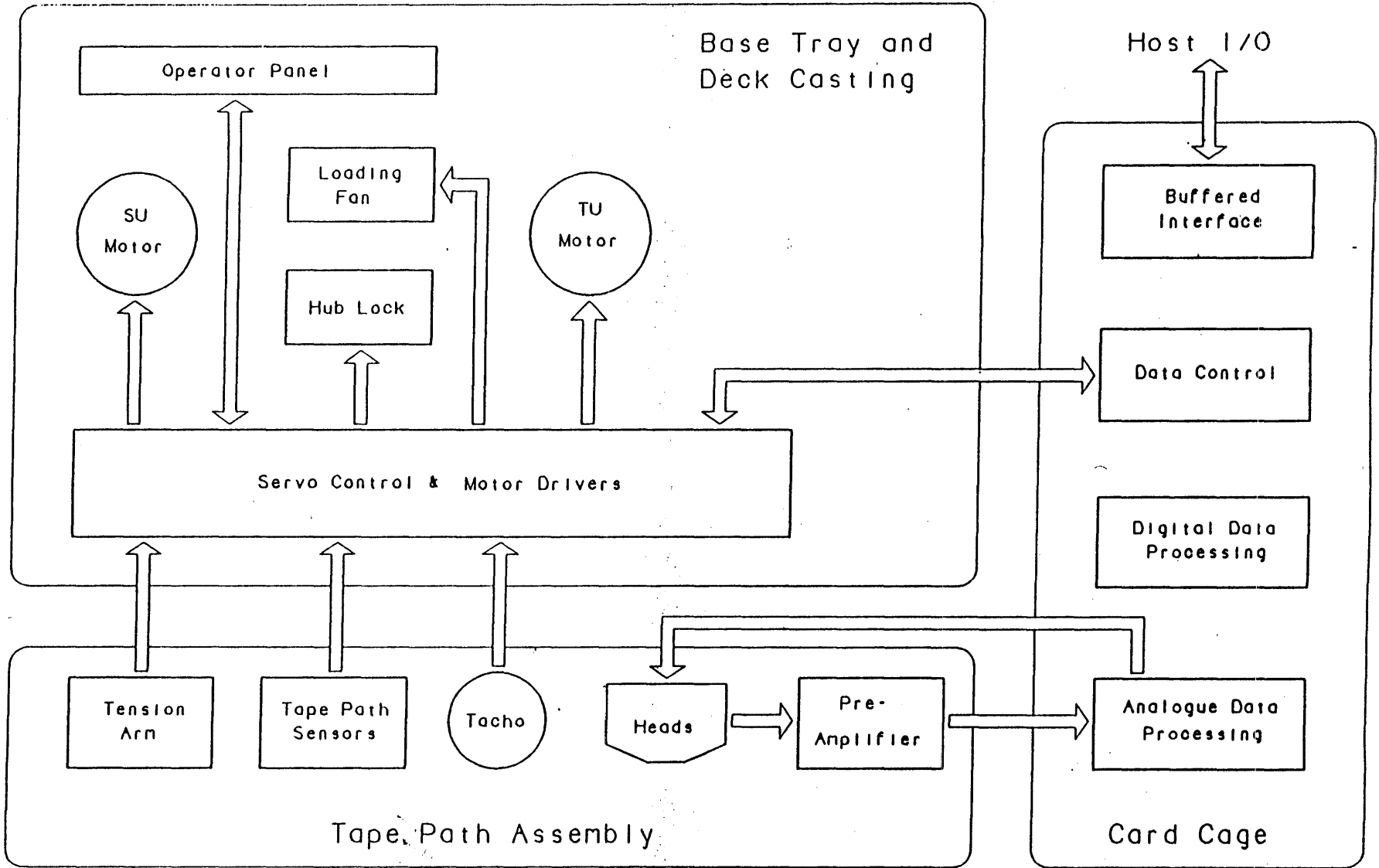

FIGURE 1.2.6 9914 BLOCK DIAGRAM

CHAPTER 1 - 9914 OVERVIEW

CONTENTS		Page
1.1	SCOPE OF MANUAL	1
1.2	9914 FEATURES	2
1.2.1	Family Background	2
1.2.2	Tape Path	2
1.2.3	Access, Modularity, and Tools	2
1.2.4	Configuration Options	3
1.2.5	Industry Compatibility	3
1.2.6	Circuit Boards	3
1.2.7	Diagnostics	4
1.3	SHORT FORM SPECIFICATION	6
1.4	STREAMING	7
1.4.1	Command Reconstruct Time	7
1.4.2	Access Time	7
1.4.3	Positioning Time	7
1.4.4	Repositioning Time	7
1.4.5	Data Rates	8
1.5	I.T. MAINS SYSTEMS	9
1.6	RFI COMPLIANCE	9
1.7	INTERFACE CABLES	9
1.8	ESD PRECAUTIONS	9
1.9	ASSOCIATED DOCUMENTS	9

1.1 SCOPE OF MANUAL

This *StorageTek* 9914 Streamer Servicing Manual provides an overall functional description, circuit descriptions, fault diagnostic guides, and servicing procedures for use by a maintenance engineer.

A companion 9914 User/Diagnostic Manual contains installation details, operating instructions, routine cleaning schedules, and diagnostic program details for the use by the installer or the operator. The features and capabilities of the 9914 are set out in a separate 9914 Product Specification.

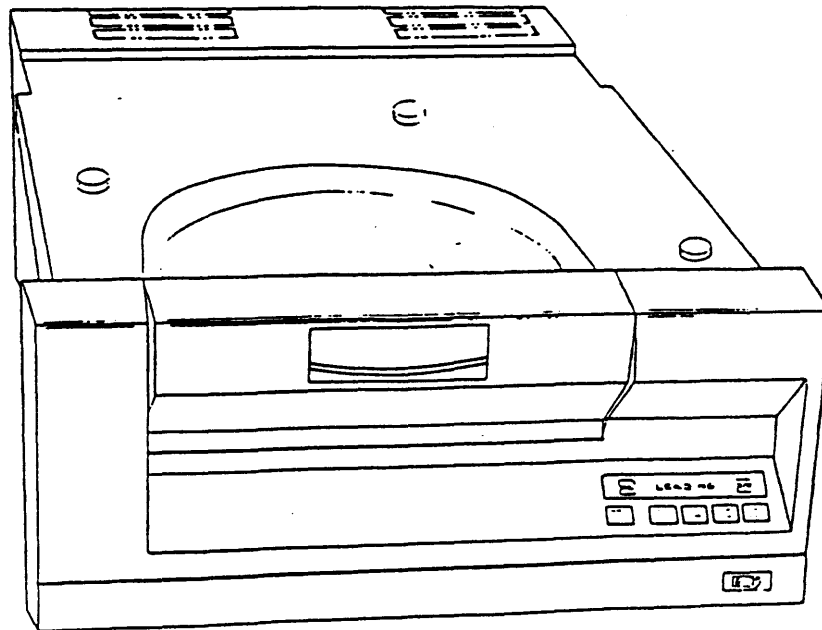

FIGURE 1.1 FRONT VIEW OF THE 9914

1.2 9914 FEATURES

1.2.1 Family Background

The 9914 streamer is a rack-mounted or desk-top, dual-speed, microprocessor-controlled tape storage peripheral, using open reels of standard half-inch computer tape on 6.0, 7.0, 8.5, or 10.5 inch IBM-style hubs. It uses many of the mechanical features of an earlier proven series of streamers, with redesigned electronics to enable GCR recording and a hinged chassis concept for ease of service access.

1.2.2 Tape Path

Any size of tape reel is positively and accurately located on the supply hub by merely posting the reel into the loading chamber and closing the loading door. The 9914 firmware then automatically centres the reel, clamps it to the supply hub, threads the tape along past the head, and takes up the free end until tape tension is established. Any malfunction is detected and conveyed to the operator via a message on the 9914 display.

A 'write enable' protection facility is designed in, to prevent the accidental erasing/overwriting of data, the user is informed when writing is enabled by means of illuminated legend in the display panel.

A tape path cover is designed to prevent operator contact with the tape while it is in motion, the cover opens for routine inspection or cleaning of the tape path; a transparent window in the tape loading door enables the presence of a tape reel to be safely observed without withdrawing the 9914 from its rack.

The 'door interlock' circuit stops tape motion and places the 9914 off-line if the tape path cover is opened at the wrong time; the tape loading door is mechanically latched from the start of the loading sequence to the end of the unloading sequence.

Removal of the tape reel (after tape has been fully rewound and the reel unclamped) is facilitated by the loading door opening automatically at the end of unloading. The customer has the option of overriding this and the 'autoload on door closure' feature.

1.2.3 Access, Modularity, and Tools

The deck chassis hinges upwards to gain access to the Power Supply board and the Servo Control board - where the tape motion control functions of the 9914 originate - (both boards being located in the base tray), and the operator control panel (located on the front moulding). Access is also gained to the tape path assembly, including the pre-amplifier, tension arm sensor circuits, and the digital tach outputs.

A motherboard in the base of the card cage connects the above boards to the Data Control, Analogue Data Paths (ADP), Digital Data Paths (DDP), and SCSI boards.

Parameters such as read gains are determined by diagnostic programs, eliminating the need for numerous readings and calculation. Servo parameters are determined by a diagnostic program, eliminating the need for special test cables and dc current meters. Special tools are available to speed up the process of setting the hub heights.

If power is removed from the 9914 when the tape is tensioned, the tape can be recovered without restoration of power. First the operator has to set the power switch to 'off'. Next rewind the tape manually onto the supply reel, then (via an access hole in the deck casting) depress a tongue to release the hub clamp mechanism. The operator can then lift off the reel.

1.2.4 Configuration Options

User options are held in non-volatile ram (NVR) on the Data Control board. This dispenses with the need to remove a board and operate links or slide switches to re-configure the unit, as well as giving increased flexibility. Not only are the firmware-orientated functions such as 'load on door closure' changed via NVR, but also the hardware-orientated unit address.

The functions of basic 9914 options and the method of altering them is described in Section 3 of this manual. The functions of buffered interface options are similarly set out in Section 3. Complete descriptions of the buffered options and board operating modes are contained either in the SCSI User Manual or the Pertec Cache Interface Product Description.

1.2.5 Industry Compatibility

The basic user interface is the industry-compatible Pertec system while the tape data format is IBM compatible to conform with both ANSI and ECMA specifications for PE, NRZ, and GCR methods of data recording.

When the SCSI interface is required, the appropriate interface board is plugged into the spare slot in the card cage to convert the SCSI protocol (as detailed in the *StorageTek 9914 SCSI User Manual*) into the 9914 internal bus format.

1.2.6 Circuit Boards

A block diagram of the 9914 is shown in Figure 1.2.6.

The Servo Control board includes a microprocessor and its EPROM memory to supervise tape motion and interface with the Data Control board and operator control panel.

The Data Control board includes a microprocessor and its memory (non-volatile RAM and EPROM) to supervise all of the data encoding/decoding procedures, the data diagnostic programs, and the Pertec interface.

The DDP board makes extensive use of Very Large Scale Integration (VLSI) circuits to encode and decode data for any of the four possible densities (800 bpi NRZ, 1600 bpi PE, 3200 bpi PE, or 6250 bpi GCR); this level of complexity is achieved on a single board by the use of surface-mount components and a multi-layer artwork.

The ADP board handles the data from the DDP board by converting it into analogue form for presentation to the write channels, at the correct write current. Conversely it takes read data from the pre-amplifier and converts it to digital form before passing it to the DDP board for decoding according to the currently selected density. Use is made of surface-mount components and a multi-layer artwork.

A pre-amplifier is placed near the head assembly to boost the head read signals, prior to being processed by the ADP board.

The SCSI board includes a microprocessor and EPROM to buffer host data and execute the ANSI command set.

The Pertec Cache Interface (PCI) board includes a microprocessor and buffer to accommodate data transfer speed differences between the host and the 9914's read/write circuits.

A Power Supply board takes ac voltages from the secondary side of the mains transformer and converts them to the required internal dc voltages.

Various small pcb's (such as the tension arm sensor circuits) form an integral part of other assemblies.

1.2.7 Diagnostics

The 9914 contains extensive diagnostic facilities and self-test routines, which provide assurance of machine integrity and aids for fault diagnosis.

When power is switched on, the self-check diagnostics verify basic requirements such as the presence of power supplies, presence of the ADP and DDP boards, and compatibility of the board builds.

A wide range of diagnostic routines may be selected from a comprehensive program suite, by the operator or the host. The SCSI board buffer is used to enable full data I/O checks, which can be selected from programs with or without tape motion. Diagnostic programs can be run individually, grouped together, or (in either case) may be continuously repeated.

Status byte registers are updated with internal conditions, error details, and diagnostic program results to enable performance assessment to be conveyed to the host computer via the interface using special 'send status byte' commands. Abbreviated versions of the same information may be displayed at the front panel by using the control buttons.

Outline diagnostic operating details are given in Chapter 3; with a complete list of program descriptions, fault codes and fault-finding suggestions.

Full diagnostic operating details are given in the 9914 User/Diagnostics Manual.

1.2.8 Data Paths

The 9914 data paths are shown in Figure 1.2.8.

The data paths consist of three or four pcb's housed in the card cage. The pcb's are interconnected via motherboard at the bottom of the cage and connected to the head and pre-amplifier by cables from the top of the ADP board.

The nucleus is the Data Control board's microprocessor, which handles the Pertec interface signals and controls the parameters and actions of the DDP and ADP boards. The DDP board houses the entire quad density encoding and decoding logic while the ADP contains all the analogue functions such as main amplification and signal conditioning.

Therefore ADP and DDP are effectively peripherals to the intelligent Data Control board, which coordinates tape motion and data channel activity during data transfer operations.

The optional fourth board in the card cage is an intelligent buffered interface pcb, which converts the unbuffered Pertec interface data into buffered SCSI data. A secondary function of these cards is to generate the diagnostic program data patterns, therefore a buffered interface is required to run data-dependent diagnostic programs.

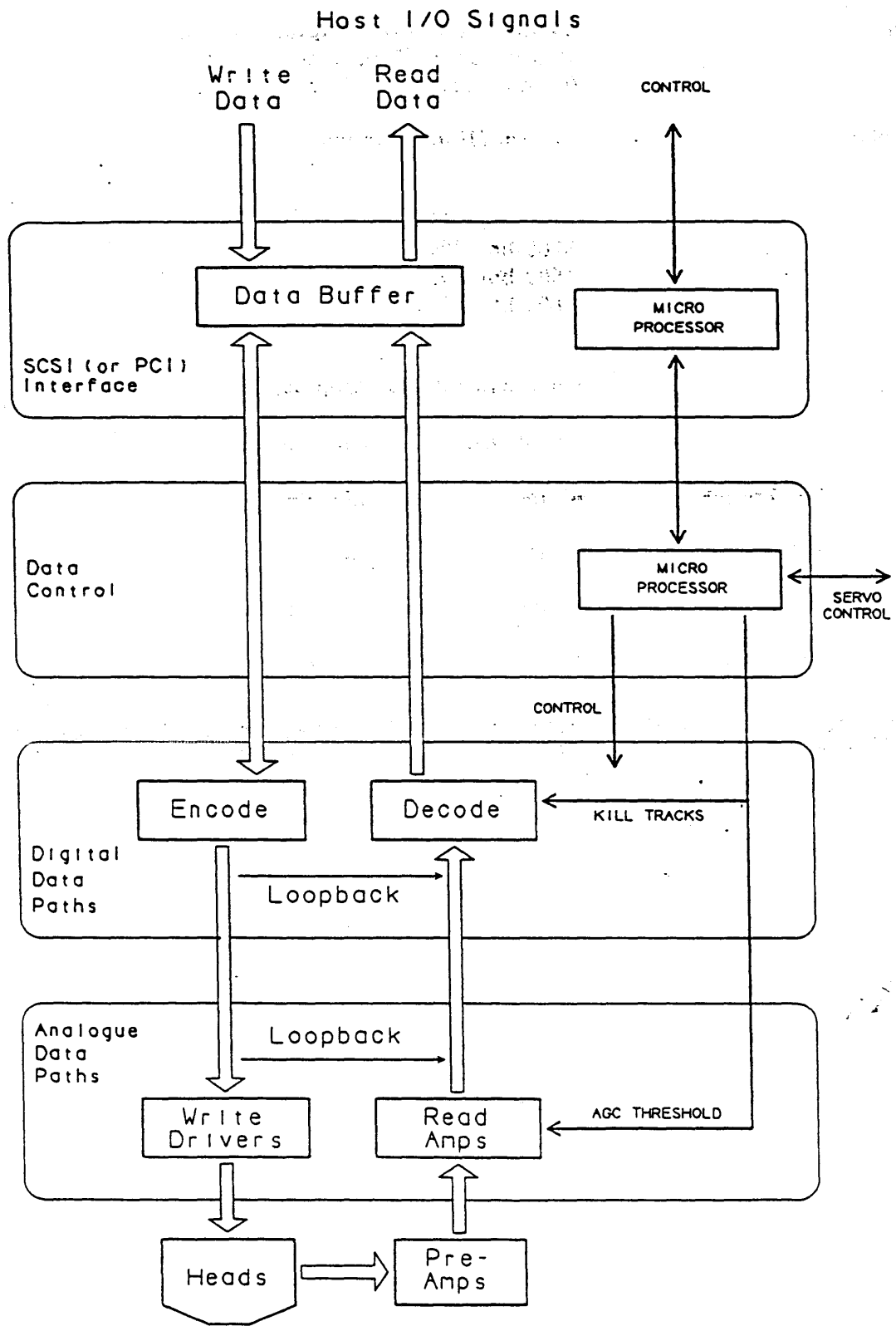

FIGURE 1.2.8 9914 DATA PATHS

1.3 SHORT FORM SPECIFICATION

Tape Type	Standard half-inch computer tape on 10.5 in, 8.5 in, 7 in, or 6 in standard IBM hub, (67 mm, 216 mm, 178 mm, or 152 mm)	
Tape Tension	285 gm (10 oz) nominal	
Formats	6250 bpi GCR, 3200 bpi PE, 1600 bpi PE, 800 bpi NRZ	
Tape Speeds	Vary with the recording density:	
	Low Speed	High Speed
800 bpi NRZ	42 ips	125 ips
1600 bpi PE	42 ips	125 ips
3200 bpi PE	62 ips	62 ips
6250 bpi GCR	42 ips	125 ips
Speed Variations	±2% long term ±4% short term	
Power Requirements	200 VA working < 35 A inrush current	
Mains Voltage Tolerance	+10% -15% of nominal input setting	
Mains Frequency	48 to 62 Hz	
Weight	36 kg rack-mount, unpacked 39 kg desk-top, unpacked	
Dimensions:		
Desk-top	245 mm H x 482 mm W x 650 mm D	
Rack (<i>behind face</i>)	220 mm H x 444 mm W x 580 mm D (8.70 in x 17.48 in x 22.83 in) (<i>rail fixing span = 427 mm, 16.81 in</i>)	
Environmental	See the 9914 Product Specification, M G0595-A	

1.4 STREAMING

To maintain streaming, the next data block must be ready for synchronous transfer before the expiry of the Command Reinject Time (CRT) at the end of the current block.

If the CRT is exceeded, a time penalty is incurred while a reposition sequence is executed; during this the tape is halted and spaced back sufficiently to allow ramping up to synchronous speed before the next block. Figure 1.4 is a simplified reposition diagram which shows tape motion past the head, if the reinstruct time (at point B) is exceeded, if no new command is received the tape halts at point F, if a new command is received it continues to the next block via point G.

A normal length inter-block gap (IBG) is written, whether streaming or after repositioning, except in special circumstances. In applications where the average host data rate is slightly lower than required by continuous streaming, the user may effectively extend the usual CRT by the 'IBG size' option (configuration byte 12), to allow more time in which to assemble the data. This gives a write time throughput advantage.

Where the average data rate is much lower than required by continuous streaming, the user may be better advised to select the lower tape speed; this may appear to be a retrograde step but calculation will reveal whether low speed with no repositions gives faster throughput than high speed with constant (longer) repositions.

If the 'IBG size' configuration option is used but the extra time allowed between 'end of data' and a new command expires, the tape repositions to point F and awaits the next command.

The above paragraphs are a brief explanation of reposition during forward write conditions. In practice the cycle may be modified on-the-fly; eg if a reverse command is received during the forward stop time, the reposition cycle is modified so that the new command is executed at the correct tape position.

1.4.1 Command Reinject Time

The command reinstruct time is defined as the time from 'end of data' to the latest point at which the next command may be accepted without a reposition cycle being executed.

1.4.2 Access Time

Access time is defined as the time taken to accelerate from stopped position to normal speed and be ready to exchange data. The access time is shown in Figure 1.4, and is unaffected by the command reinstruct time.

1.4.3 Positioning Time

The positioning time is defined as the time taken to reach the stopped position (point F) in readiness for the next command, when no new command is received before the end of the command reinstruct time.

1.4.4 Repositioning Time

The repositioning time is defined as the time taken to regain streaming speed (via points B to G); this assumes that a new command is received between points B and F.

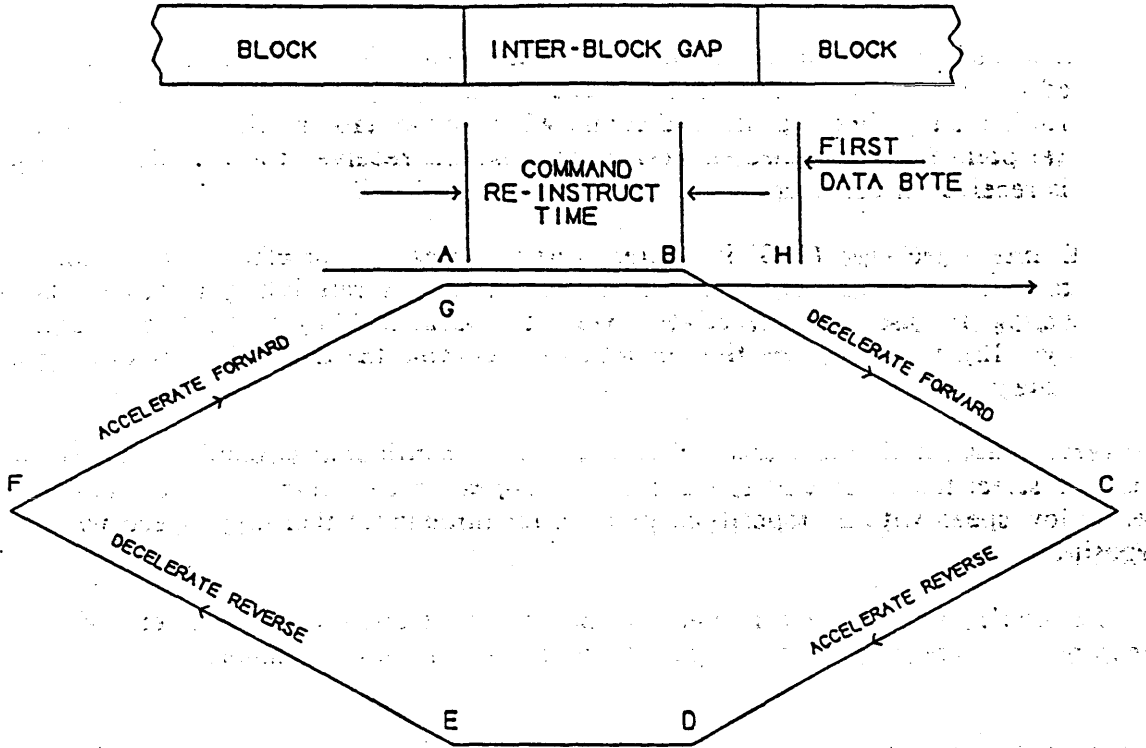

FIGURE 1.4 TYPICAL REPOSITION CYCLE

1.4.5 Data Rates

When a data is being transferred to tape, the data rate is determined by the tape speed and recording density (GCR, PE or NRZ). At 800, 1600, and 6250 bpi, the user may select from two streaming speeds. The inter-relationship of tape speed, average data rate (and data period) for the Pertec interface is detailed in Table 1.4.5. Note that the burst rate will be higher.

Density (bpi)	NRZ 800	PE 1600	DPE 3200	GCR 6250
Speed (ips)	41.66 125	41.66 125	62.5 62.5	41.66 125
Data rate (kbytes/s)	33.3 100	66.6 200	200 200	260 781
Data period (us)	30 10	15 5	5 5	3.84 1.28

TABLE 1.4.5 9914 DATA RATES

Note: the tape speeds normally referred to as '42 ips' and '62 ips' are actually 41.66 ips and 62.5 ips.

1.5 I.T. MAINS SYSTEMS

Definition: An I.T. mains system is defined as one having the neutral line held at a substantially different voltage to that of the earth line.

WARNING: THE 9914 MUST NOT BE CONNECTED TO I.T. MAINS SYSTEMS.

1.6 RFI COMPLIANCE

The 9914 Streamer is designed to meet certain RFI requirements in *industrial* use. However, if the 9914 is operated in a *residential* environment it has a high potential for causing interference.

Where the 9914 is not enclosed within a cabinet where precautions are taken to limit radiated emission, screened cables and connectors must be used. Suitable connectors such as 3M socket type 2565-2002, or Sun-style (3M type 8350-9005) may be already be fitted to the SCSI models of the 9914 when delivered.

1.7 INTERFACE CABLES

Where unscreened interface cable is acceptable, 3M type 3365 may be a suitable flat ribbon cable with 3M type 3415-0001 connector at the 9914.

Where a screened cable is required, 3M type 3517 may be suitable where a flat ribbon cable is desired; where a round jacketed ribbon cable is required, 3M type 3659 may be suitable.

A compatible socket connector should be used which mates mechanically (at the rear of the 9914) with 1.6 mm (0.064") printed edge connections. In screened applications this connector is likely to require a conductive shell.

1.8 ESD PRECAUTIONS

When some sub-assemblies are removed, it is necessary to disconnect earth bonding straps. These may appear to perform no electrical function, but they must be re-connected in order to maintain good protection against electro-static discharge and to ensure RFI compliance.

Printed circuit boards should be treated in accordance with local ESD regulations, which are outlined in Chapter 4.

1.9 ASSOCIATED DOCUMENTS

The following documents are published by *StorageTek* to give specific product information:

95 121797	9914 Streamer User/Diagnostic Manual
95 121798	9914 SCSI User Manual
95 121799	9914 Pertec Cache Interface Product Description
M G0595-A	9914 Streamer Product Specification

The international standards on data recording and safety are listed in the 9914 Product Specification.

This page has no technical content.

CHAPTER 2 - PCB DESCRIPTIONS

CONTENTS

	<i>Page</i>
2.1 SCOPE OF CHAPTER 2	1
2.2 SERVO CONTROL BOARD DESCRIPTION	2
2.3 DATA CONTROL BOARD DESCRIPTION	11
2.4 ANALOGUE DATA PATHS BOARD DESCRIPTION	14
2.5 DIGITAL DATA PATHS BOARD DESCRIPTION	21
2.6 PRE-AMPLIFIER DESCRIPTION	24
2.7 POWER SUPPLY BOARD DESCRIPTION	25
2.8 SCSI BOARD DESCRIPTION	29

2.1 SCOPE OF CHAPTER 2

Chapter 2 contains functional descriptions of the major pcb's.

The relevance of these boards within the 9914 is described in Chapter 1.

Fault finding techniques are described in Chapter 3.

The circuit descriptions are related to signal activity when in operation, and enable fault tracing to the signal source/destination on the board (having first used the diagnostic programs to identify the suspect area). Having established that the board is interfacing correctly, the next stage will normally consist of board substitution. On-site diagnosis down to chip level is not anticipated, partly because extensive use is made of surface-mount components, and partly because down-time is reduced by sub-assembly substitution.

Repair or modification of the surface-mount components should not be attempted without suitable surface mount rework facilities.

CAUTION

All the boards described here include CMOS integrated circuits and/or CMOS components, for this reason the usual static precautions should be observed when handling them.

2.2 SERVO CONTROL BOARD DESCRIPTION

CONTENTS

	<i>Page</i>
2.2.1 Overview	2
2.2.2 Control Method	3
2.2.2.1 Introduction	3
2.2.2.2 Functional Outline	3
2.2.3 Hardware Descriptions	3
2.2.3.1 Microprocessor and Associated Circuits	3
2.2.3.2 Power-on Reset	3
2.2.3.3 Processor OK	4
2.2.3.4 Crystal Oscillator	4
2.2.3.5 Power Failure	4
2.2.3.6 Communication with Data Control	4
2.2.3.7 Tacho Phases	6
2.2.3.8 Motor Drives	6
2.2.3.9 Operator Panel	7
2.2.3.10 Loading Tape	8
2.2.3.11 Write Enable	10

2.2.1 Overview

The Servo Control board, part number 121050, contains the following sub-system circuits:

(a) Interface circuits:

- to register signals from the operator panel, for interpretation by the microprocessor;
- to transfer indications to the operator's 8-character alpha-numeric operator panel display;
- to communicate with the Data Control board, controlling tape motion which corresponds to the last accepted command (from the host or operator);
- to drive the hub lock mechanism;
- to drive the loading fan.

(b) Analogue circuits:

- to process the tape speed data (ie the processed tacho output pulses) and complete the control loop by deriving the take-up motor drive current;
- to process the tape position data and derive the offset value which is applied to the supply motor current, thereby compensating for the varying radius of the tape stack.

(c) Miscellaneous circuits:

- to accept the tape path sensor receiver signals;
- to drive the tape path LED sensor transmitters;
- to perform A/D conversion on some supply rails;
- to process the tacho phases, giving speed and direction;
- to access the operational and diagnostic firmware in PROM.

2.2.2 Control Method

2.2.2.1 Introduction

Control of the 9914 Streamer servo circuits is effected by an 8-bit microprocessor system. A block diagram showing the location of the Servo Control board within the 9914 is given as Figure 1.2.6, and a block diagram of the microprocessor and control system is given as Figure 2.2.2.

2.2.2.2 Functional Outline

As can be seen from Figure 2.2.2 this board is a key element in the overall control of the machine. It monitors and controls the operator-panel buttons/display, it interprets tape path sensors in relation to handed-on requests from the Data Control board, and it controls the reel motors to provide whatever action is required at any given time.

As the board design is microprocessor based, the real controlling element is the firmware.

The Servo Control board is essential for even a basic check of the 9914. With a known good Servo Control board and Power Supply, power may be switched on and a tape loaded to BOT, without any boards being present in the card cage.

2.2.3 Hardware Descriptions

For the purpose of this description, the hardware design has been divided into sub-sections, each of which is discussed separately.

2.2.3.1 Microprocessor and Associated Circuits

The microprocessor used is the standard 8051-compatible (with 16-bit address and 8-bit data output); the address bus is latched by IC39, using the ALE output. 256 bytes of RAM reside within the processor.

The processor clock input is derived from the crystal oscillator circuit, and buffered by IC20.10 for use elsewhere on the board.

External PROM (IC23) accepts the 16-bit address directly from the processor and places the memory data on the p0.0-p0.7 bus inputs, when the PSEN signal is active.

I/O is achieved via 8-bit ports, typically a 74LS541 for inputs and a 74LS273 for outputs; each port is selected by a CS0-7 enabling input, derived from the addresses (A3-A5 & A13-A15) decoded by IC36.

2.2.3.2 Power-on Reset

When power is first applied to the board, input pin 10 to the processor is low because C65 is in a discharged condition. After approximately 50 ms, C65 charges to above the TTL threshold via R140. The processor is then free to execute instructions while C65 charges further to a value near +5 V.

If power fails, C65 discharges very quickly (via D33) into the +5V rail, this mechanism ensures a reset condition even after short power breaks. The data and address lines are tri-state during reset.

2.2.3.3 Processor OK

After power is applied to the board, the processor carries out a self-check routine. When this check is successful, IC27.19 is driven high to illuminate the on-board led, indicating a good condition without reference to the operator panel display. The SPROC_OK signal is used at the Data Control board to allow release of its reset circuit; if the servo processor is not ok, the data processor is not allowed to function.

2.2.3.4 Crystal Oscillator

The processor contains a circuit to maintain oscillation in an external crystal, which is connected to the x1 & x2 pins (20 & 21). A 10.0 MHz crystal is used, with capacitors C58 & C59 to trim the frequency.

2.2.3.5 Power Failure

The +24V and +12V rails are monitored directly at the ADC chip IC11, with the +5V, -5V, and -12V rails monitored at IC11 via resistor networks. Levels outside $\pm 10\%$ in the +12V rail are detected by the processor, the other rails may vary by the same or greater amounts (depending on the ADC input circuit) before a failure condition is logged and the POWER message placed on the operator panel display.

The +5V rail is not specifically monitored, since this supplies the power to the processor, which is effectively the power fail detector.

If the servo supply (designated V_s , nominally +48 V) falls in value, the 9914 continues to operate at lower levels of performance; should the +48V rail ever reduce severely, the +24V rail (which is derived from it) will move to a level which causes a power fail detection.

PWR_FAIL enters the board at P4/12, from the Power Supply board, this signal is combined with RELAY_ON (see later) to generate RLY_ON which causes SERV_RST (servo reset) when active. RELAY_ON is active when RLA is energised (placing a short across both reel motors) to give a regenerative braking action should the control circuits lose effect. Primary power failure also causes regenerative braking.

2.2.3.6 Communication with the Data Control board

(a) Outputs

Output messages are sent via two 74LS374 registers, byte by byte (over the 8 bi-directional SVD0-7 lines), handshaking being performed by the Data Control board processor.

Output conditions such as 'servo processor ok' (SPROC_OK) are transmitted separately over dedicated uni-directional lines to the Data Control board.

Signal	Source	Route	Edge Pin
SPROC_OK	IC27.19	-	P4-18
EMPTY	IC3.13	-	P4-24

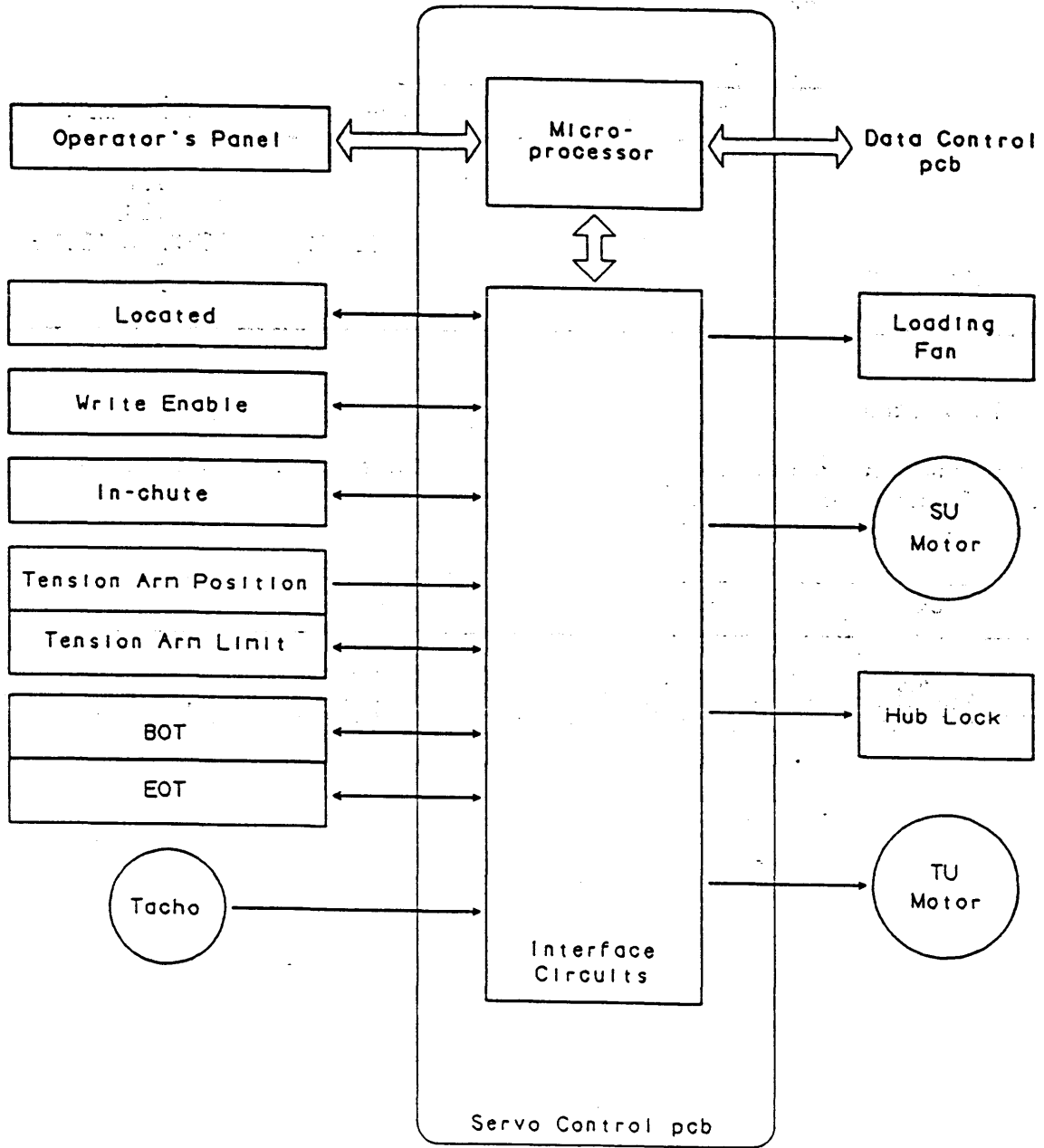

FIGURE 2.2.2 SERVO CONTROL BLOCK DIAGRAM

(b) Inputs

Input messages will have been stacked up in the FIFO chips (IC18 & IC32) by the Data Control board, having arrived as a packet via the 8 bi-directional SVD0-7 lines with the SVRD0 & SVRD1 signals.

Input conditions such as 'data processor ok' (DPROC_OK) are received separately over dedicated uni-directional lines from the Data Control board.

Signal	Edge pin	Route	Destination
SVRD0	P4-4	-	IC24.1
SVRD1	P4-3	-	IC43.1
SVWT	P4-10	IC21.13, IC21.12	IC18.3 & IC32.3
DPROC_OK	P4-15	-	IC18.9

2.2.3.7 Tacho Phases

The tacho produces two phases separated by 90 degrees, both phases are routed via the distribution board to the Servo Control board connector P5. Once on-board, they are buffered and connected directly to the processor for interpretation of tape speed and direction.

Phase	Edge pin	Route	Destination
Tach1	P5-8	IC20.13, IC20.12	IC22.14
Tach2	P5-10	IC20.3, IC20.4	IC22.17 & .2

2.2.3.8 Motor Drives

(a) General

The motor drive circuits form part of a reel-to-reel control philosophy, tape speed demand determines the current through the TU motor, while tape tension (measured in terms of tension arm position) determines the current through the SU motor; these two currents are calculated independently by the Servo Control processor.

(b) Drive Currents

The processor outputs a digital code representing the motor drive demand, which is converted to an analogue level at IC12. These analogue demand signals SUDEM & TUEM are processed with other signals which determine the direction of tape motion (SUREV & TUREV), before being converted to switched mode signals (at IC5/IC6) and used to drive the FET H-bridge configuration (eg TR9 - TR12).

(c) Feedback

The back EMF from either motor is processed at IC1 to give a voltage level which is converted to a digital code at IC11. The processor uses these feedback values to maintain the motor currents required by the demand voltage, in the presence of any parameter variations in the overall control loop.

2.2.3.9 Operator Panel

(a) Buttons

The five operator panel buttons are all momentary action membrane switches; any change in their condition will appear at input port IC28 and be registered by the processor at the next I/O read of that input port.

Button	Edge pin	Route	Destination
DIAG	P6-50	(RN2.2)	IC28.5
LD/ONL	P6-48	(RN2.3)	IC28.6
REW/UNL	P6-46	(RN2.4)	IC28.7
RESET	P6-44	(RN2.5)	IC28.8
DENSITY	P6-42	(RN2.6)	IC28.9

(b) Legends

The four back-lit status legends are driven from processor output ports.

Legend	Port	Route	Edge Pin
WT EN	IC38.16	IC42.11, IC42.10	P6-38
ONLINE	IC38.19	IC42.5, IC42.6	P6-40
DIAG	IC41.19	IC42.3, IC42.4	P6-39
EOT	IC41.16	IC42.9, IC42.8	P6-37

(c) 8-Character Display

Diagnostic program 72 checks out the operation of all the display elements, run this program before investigating a suspected display fault.

The display is an 8-character LED presentation. Data (DD0 - DD7) is sent to the display from output port IC40 and control signals (DA0 -DA2, SEL, & DWT) from IC38. The display character is selected by signals DA0 thru DA2, the chip is selected by SEL, and the character strobed in by WRT (to be stored in RAM until changed again).

Signal	Port	Route	Edge Pin
DD0	IC40.2	-	P6-28
DD1	IC40.5	-	P6-26
DD2	IC40.6	-	P6-24
DD3	IC40.9	-	P6-22
DD4	IC40.12	-	P6-20
DD5	IC40.15	-	P6-18
DD6	IC40.16	-	P6-16
DD7	IC40.19	-	P6-14
DA0	IC38.2	-	P6-2
DA1	IC38.5	-	P6-4
DA2	IC38.6	-	P6-6
SEL	IC38.9	-	P6-8
DWT	IC38.12	-	P6-7

2.2.3.10 Loading Tape

The sequence of events when loading tape are described here, the sensors which are involved may be checked out by using diagnostic program 45, as described in Chapter 3 under 'diagnostic programs'.

(a) Initiation

The loading procedure is initiated by the operator closing the loading door, by setting power on, or by pressing LD/ONL (configuration option 04 determines which). Door closure is communicated to the processor via IC26.8.

If option byte 04 is set to MAN ONL, it is necessary to press the operator panel LD/ONL button to initiate loading.

When the door (or tape path cover) is not fully closed at the point of initiating load, then the respective IC26 pin is high and a DOOR (or LID OPEN) message is sent to the 8-character display with the loading sequence inhibited until the hold condition is corrected.

Signal	Edge pin	Route	Destination
LD/ONL	P6-48	(RN2.3)	IC28.6
DOOR	P6-10	(R141)	IC26.8
LID	P6-12	(R144)	IC26.9
LOCATED	P5-32	IC34.1, IC34.2	IC26.6

(b) Locating

In order to locate the reel on the supply hub crown, the supply motor is reciprocated slowly forward and reverse until all three flags are detected as 'down', during this time the LOCATING message appears on the display. The 'located' pulses arrive at IC26.6 and are timed by the processor to determine 'fully located' (all three flags down), or a HUB ERR 1 (or HUB ERR 2) condition whereby one (or two) flag are considered to be absent (ie not interrupting the sensor beam).

(c) Locking

When the reel is fully seated on the supply hub, it has to be clamped by mechanical means. The control firmware places the LOCKING message in the display and activates DOOR_SOL and PULL_IN from output port IC41 for about one second. These signals are interfaced with the +24V/+12V supplies by resistor drivers to first generate a high current to pull in, then to reduce to the hold current value. The supply motor current is then ramped up to produce the torque required for reel clamping. If clamping is unsuccessful it will become evident at a later stage.

Signal	Source	Route	Destination
PULL_IN HUB_SOL DOOR_SOL	IC41.9 IC41.15 IC41.12	IC31.5, IC31.6 IC31.11, IC31.10 IC31.9, IC31.8	D30- D31- D32-

(d) Loading

Having driven the reel clamp solenoid, the firmware places the LOADING message in the display and then switches on the loading fan by activating the driver circuit based around TR3 (fan on = 1.0 V, fan off = 24 V). The resulting stream of air normally blows the tape passed the 'in chute' sensor (P5/4). If tape does not appear in the chute, a fault is flagged and the N I C (not in chute) message is placed in the operator panel display. If the reel was not successfully clamped, the N I C condition may result, alternatively there may be sufficient friction between hub and reel to give an in-chute condition.

Signal	Source	Route	Edge Pin
FAN_ON CHUTE	IC22.5 IC22.7	IC42.12, TR3 IC30.8, TR21	P3-1 P5-6

After detecting tape in the chute, the SU reel is driven in reverse until tape is no longer 'in chute' and then forward until it is 'in chute' for the second time. This manoeuvre is a precaution to detect an inverted reel of tape, if successful the firmware continues to feed tape forward. If the reel was not successfully clamped, this stage will not be accomplished.

Signal	Source	Route	Destination
IN CHUTE LIMIT ARM Tacho BOT	P5-4 P5-28 P5-24 P5-20	IC34.9, IC34.8 IC34.3, IC34.4 IC10.6, IC10.7 See Section 2.2.3.7 IC34.13, IC34.12	IC26.7 IC26.5 IC11.26 IC26.3

Next the TU servo is commanded to rotate the TU spool slowly in the forward (ie anti-clockwise) direction so that the tape which is being fed along the tape path will be attracted to the centre of the TU hub and be pulled tight against the tacho. When the firmware has detected several revolutions of the tacho, its output then becomes the source of tape motion information. Forward tape motion is maintained by applying opposing motor torques, but with sufficient imbalance to overcome the tension arm spring.

When the tension arm reaches mid-position, the firmware initiates normal forward tape motion at low speed until the BOT tab is detected (the tension arm output can be checked by the methods described in Chapter 4). Should tape lodge in the tape path and fail to reach the TU hub, the N T U (not taken up) message is placed in the operator panel display.

After tape has been taken up, the loading fan is switched off.

While running forward to BOT, the processor is able to determine the reel size by relating the tape speed to the number of 'reel located' pulses per second. The size is indicated in the operator display and stored by the control firmware for servo algorithms.

When BOT is detected, the processor changes the display to BOT and halts the tape. This is the end of the tape transporting portion of the load cycle; if no BOT tab is detected within a certain distance, then the tape is all rewound onto the supply reel (with UNLOAD displayed), awaiting some corrective action by the operator.

When (as is usually the case) option byte 06 is set to enable the analyse function, the tape is next shuffled to and fro while the Data Control attempts to establish the recorded density; the various end results of this are implied in Section 3.14.

(e) Tape Already Laced

This is a special case of the load procedure, invoked on initial power-up (or power restore) or after manually threading the tape (which should be only necessary following a loading fan failure).

If the control firmware senses that the tape is in-chute, the supply reel is clamped (it may well already be clamped but there is no fail-safe method of establishing this) and the tape is tensioned. The tape is then moved forward in search of the BOT marker and stopped with BOT indicated if the marker is found. Otherwise (after about 4 metres search) the tape is moved in reverse at low speed until BOT is found; the low speed is selected for safety because the firmware has not yet been able to determine the reel size.

2.2.3.11 Write Enable

When a supply reel is used with a 'write enable' ring fitted, the ring sensor flag is depressed and the output of the sensor (FPTD) appears at P5/34. This signal is used by the processor to drive the WT EN legend, and transferred to the Data Control board to forestall any 'write' or 'erase' type commands being carried out.

Signal	Source	Route	Destination
FPTD	P5-34	IC34.5, IC34.6	IC26.2

2.3 DATA CONTROL BOARD DESCRIPTION

CONTENTS

	<i>Page</i>
2.3.1 Overview	11
2.3.2 Micro-processor System	11
2.3.3 Communication with the Servo Control board	11
2.3.4 Pertec Interface	12
2.3.5 Mode Selection	13

2.3.1 Overview

The Data Control board, p/n 121600 (and the later p/n 123638), contains hardware to communicate with the data channel (ADP and DDP) boards, Servo Control board, and the host (ie Pertec) interface. A microprocessor is used to handle the various tasks, namely:

- to act upon inputs from the operator panel (relayed via a communication link with the Servo Control board), and transfer messages back to the Servo Control board so that their actions are co-ordinated;
- to notify the VLSI on the DDP board of the current density;
- to set AGC levels on the ADP board, and the gain of the pre-amplifier channels;
- to store and decode the standard options and configuration (in EPROM);
to store the current default options and configuration (in NVR);
- to verify, accept, and decode new commands from the Pertec interface;
to control the signals sent to the Pertec interface;
- to co-ordinate the actions of the ADP & DDP boards, in order to execute host commands;
- to execute the data-related parts of diagnostic programs.

2.3.2 Micro-processor System

A 64180 8-bit CMOS processor, accessing a non-volatile memory (NVR) for storing user-selectable configuration option settings, and EPROMS for the control data needed to supervise the DDP and ADP board actions. A special 'packet transfer' message exchange is used to communicate with the Servo Control board, and four encoded mode lines (reflecting tape speed and density) are available to all the other boards.

Extensive use is made of firmware control and I/O bus signals, reducing the amount of gated logic to a small proportion of the circuits.

2.3.3 Communication with the Servo Control Board

The Data Control processor is not allowed to function if the Servo Control processor is not ok, the processor reset input (IC12.7) is held low until the servo processor has completed its self-check.

Communication with the Servo Control board consists of sending message packets over the bi-directional bus SVD0 - SVD7, accompanied by control and strobe signals SVWT, SVRD0, and SVRD1. The Servo Control board contains the FIFO chips which store the messages; the operation of the exchange is outlined in Section 2.2.

Signal	Source	Route	Edge Pin
SVRD0	IC45.6	-	P3-12a
SVRD1	IC36.6	-	P3-16b
SVWT	IC45.3	-	P3-10b
DPROC_OK	IC13.10	-	P3-10a

2.3.4 Pertec Interface

Input signals are terminated by 220/330 resistor networks and routed typically to an input port or exceptionally (eg the address and enabling inputs) to gated logic.

Signal	Edge Pin	Route	Destination
IFEN	P2-22b	IC49.1, IC49.2	IC34.3
IFAD	P2-20b	-	IC40.12
ITAD0	P2-19b	-	IC40.13
ITAD1	P2-20a	-	IC40.15
ILOL	P2-32a	-	Not used
IHISP	P2-24b	IC48.11, IC48.10	IC22.4
IREV	P2-22a	IC49.5, IC49.6	IC22.8
IWRT	P2-25b	IC49.9, IC49.8	IC22.13
IWFM	P2-24a	IC49.11, IC49.10	IC22.14
IEDIT	P2-25a	IC49.13, IC49.12	IC22.17
IERASE	P2-23a	IC49.3, IC49.4	IC22.18
IGO	P2-23b	IC48.1, IC48.2	IC47.2
IWD0	P3-31a	-	IC57.9
IWD1	P3-30b	-	IC57.5
IWD2	P3-28a	-	IC58.6
IWD3	P3-29a	-	IC57.4
IWD4	P3-32b	-	IC57.7
IWD5	P3-27b	-	IC58.7
IWD6	P3-28b	-	IC57.2
IWD7	P3-29b	-	IC57.3
IWDP	P3-30a	-	IC57.6
ILWD	P3-32a	-	IC57.8
IREW	P2-18b	IC48.5, IC48.6	IC31.12

The *StorageTek* interface protocol and command set is configured in the non-volatile memory for verification purposes (the configuration bytes in NVR may be changed to accept non-standard commands or change the functions of input pins).

Incoming commands are accompanied by the host's IGO pulse, which is gated with SEL (IC31.8) and GO_SW (which determines the active edge of IGO). NEW_CMD (IC32.9) sets the processor in motion to verify the command and act accordingly. The foregoing is conditional on the IFEN signal allowing commands to be accepted by the 9914, ie 'LS74 IC34.6 being high.

During diagnostic program operation, the 'read', 'write' and other commands are generated by the SCSI board, therefore appearing to the other boards as normal Pertec inputs. Output signals are buffered by invertors after being registered at output ports IC26 & IC28 and enabled onto the Pertec bus by SEL (which is inverted to give IONL), denoting that this unit is currently selected).

Signal	Source	Route	Edge Pin
IONL	IC31.8	IC56.3, IC56.4	P2-12a
IRDY	IC50.6	IC56.5, IC56.6	P2-11b
IFPT	IC38.11	IC55.9, IC55.8	P2-15a
ILDPA	IC39.8	IC55.3, IC55.4	P2-16a
INRZ	IC39.3	IC55.13, IC55.12	P2-13a
ISPEED	IC51.8	IC54.11, IC54.10	P2-18a
IFBY	IC38.6	IC56.13, IC56.12	P2-11a
IDBY	IC51.11	IC56.9, IC56.8	P2-10a
IIDENT/ICCG	IC51.6	IC55.11, IC55.10	P2-14a
IRD 0-7	DDP board	-	
IRSTR	DDP board	-	
ICER	IC50.11	IC54.13, IC54.12	P2-17b
IHER	IC50.8	IC55.1, IC55.2	P2-15b
IFMK	IC51.3	IC55.5, IC55.6	P2-17a
IWSTR	DDP board	-	
IEOT	IC39.11	IC56.11, IC56.10	P2-10b
IRWD	IC50.3	IC56.1, IC56.2	P2-12b

The Pertec interface lines are present at the option board slot so that the 306 x 195 mm SCSI interface board can be used without modification. Communication with the SCSI board is largely via the Pertec bus, using unallocated command codes of the IREV ... IERASE lines and the otherwise redundant IDGM line.

2.3.5 Mode Selection

4 mode selection signals, MODE0 - MODE3, are available at IC25 for other boards. MODE0, MODE1 & MODE2 select the density while MODE3 selects the speed as follows:

Signal		MODE0	MODE1	MODE2	MODE3
Meaning		(NRZ)	(GCR)	(3200)	(Lo Speed)
Source		IC25.2	IC25.5	IC25.6	IC25.9
Edge Pin		P1-12b	P1-12a	P1-13b	P1-13a
<i>Encoding</i>	<i>Speed</i>				
NRZ	low	1	0	0	0
NRZ	high	1	0	0	1
PE 1600	low	0	0	0	0
PE 1600	high	0	0	0	1
PE 3200	low	0	0	1	0
GCR	low	0	1	0	0
GCR	high	0	1	0	1

Note that although the 3200 bpi tape speed (62.5 ips) is low by comparison with 125 ips, it is higher than the usual low setting of 42 ips, therefore is returned as 'high speed' by the Pertec ISPEED status line.

The density can only be changed at BOT, so will remain constant for most operations, speed however can vary from one command to the next; the MODE signals are updated just prior to executing a command.

2.4 ANALOGUE DATA PATHS BOARD DESCRIPTION

<i>CONTENTS</i>		<i>Page</i>
2.4.1	Overview	14
2.4.2	Write Channels	14
2.4.2.1	Write Drivers & Buffers	14
2.4.2.2	Current Definition	14
2.4.2.3	Write Power Control	15
2.4.2.4	Write DAC's and Control Buffers	16
2.4.3	Read Channels	16
2.4.3.1	PE/GCR Densities	16
2.4.3.2	NRZ Density	18
2.4.4	E-E Mode	20
2.4.5	Calibration	20

2.4.1 Overview

The ADP board, part number 121710, contains hardware to communicate with the DDP board, the write heads, and the read channels from the pre-amplifier. Its operational parameters (eg read amplifier gain, read threshold and write current settings) are generated by the Data Control board, allowing the processing of data at four densities and two tape speeds. ADP functions may be subdivided into:

- the write data circuits, which receive formatted digital data from the DDP and convert it to currents suitable for driving the 9-track write head stack;
- the read data circuits, which receive the analogue signals from the read head stack (after boosting by a local pre-amplifier), amplify them further, digitise them, and pass them to the DDP board for data decoding and de-skewing.

Combinations of speeds from 42 to 125 ips and data densities of 800/1600/3200/6250 bpi have been met by digital control of the write current (shape and magnitude), the read gains, and the channel bandwidths.

2.4.2 Write Channels

See Figure 2.4.2(a).

2.4.2.1 Write Drivers & Buffers

Digital write data signals WDOUT0 through WDOUT7 from the DDP board are routed to the write driver chips (one per channel) and converted to analogue current levels to feed pairs of buffer transistors in common-base configuration. Each transistor drive circuit includes impedance matching components and drives the relevant leg of the channel write winding via the head cable.

2.4.2.2 Current Definition

The shape of the write current waveform can be controlled to give either a step and pedestal (in GCR) or a square wave (DPE, PE and NRZ), see Figure 2.4.2(b). The amplitudes of the step and pedestal are separately controlled by voltages from the write control DAC's. The timing of the step is controlled by the STEP_CLK signal from the DDP board. The write drivers can be inhibited by a single logic signal, allowing separate switching of the write current and erase current.

Head current is drawn from the +12V rail and returned via a dedicated ground.

2.4.2.3 Write Power Control

This block ensures that current is only supplied to the head windings under specified safe conditions. A UC3903 power supervisory chip is used to monitor the +12V, +5V, and -6V rails to about 15% tolerance, the ok condition enables the series IRF9351 mosfet to allow +12V to the write winding centre-taps (and the erase head) when the WRITE signal is active. The ok condition is:

- +12V, +5V, and -6V all within +15%, and
- PWR_FAIL (from the Power Supply board) not asserted, and
- SPROC_OK (from the Servo Control board) asserted.

Current flow in the head windings is detected by activity on the ERASE- signal and used to provide the WTNG signal (used by the Data Control board) as an indication that writing is in progress.

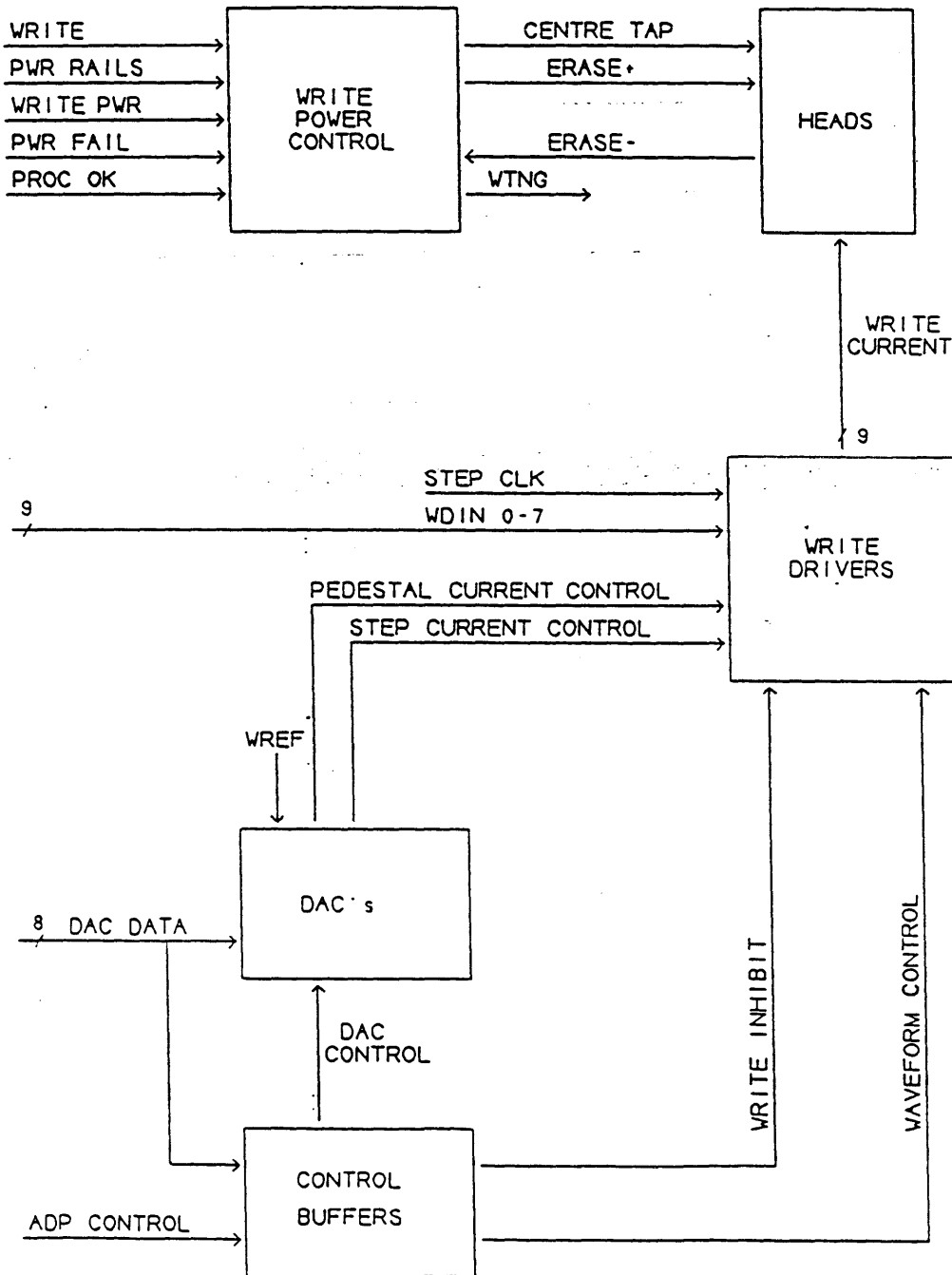

FIGURE 2.4.2(a) ADP WRITE BLOCK DIAGRAM

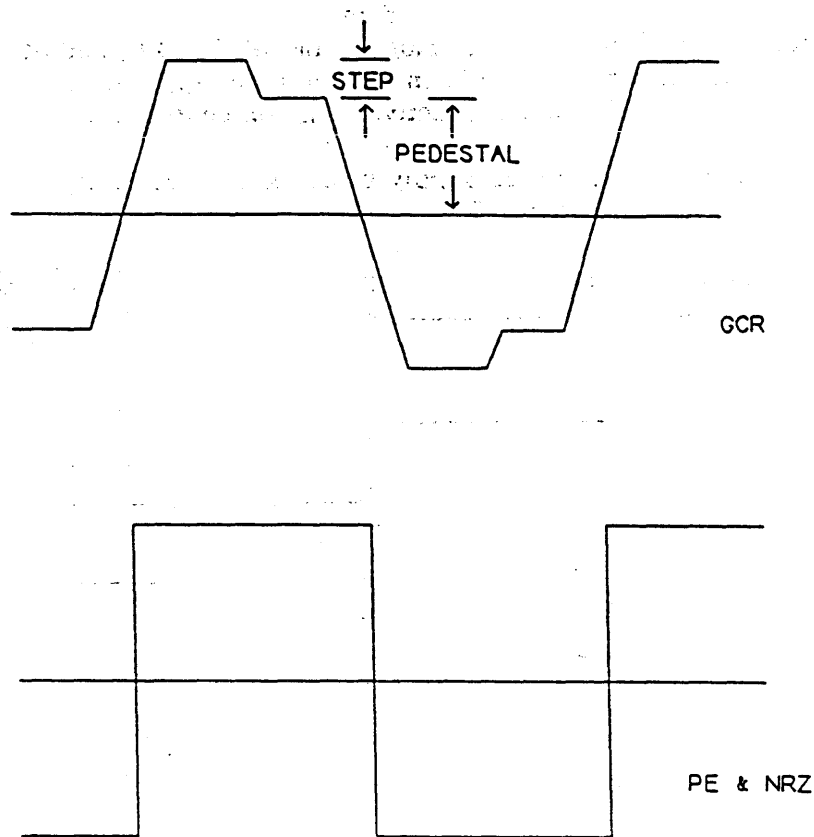

FIGURE 2.4.2(b) WRITE CURRENT WAVEFORMS

2.4.2.4 Write DAC's and Control Buffers

An 8-bit data bus (common to the read circuits) and associated control lines are sent from the Data Control board. The control lines provide selection of the DAC's and buffers and clocking of the data.

The outputs of the DAC'S are buffered to provide the correct control voltages for the full range of pedestal and step currents allowed by the write drivers. The control buffers provide signals to inhibit the write drivers, to ensure that the write current is completely switched off when not required, and to control the current waveform shape

2.4.3 Read Channels

Each read channel differential signal from the pre-amplifier (at about 100 mV peak-peak amplitude) is routed to a differentiator based on a NE592 chip on the ADP board. The read signal processing circuits are internally re-configured according to the current density, resulting in two basic modes, GCR/DPE/PE and NRZ. For ease of understanding, the modes are discussed separately.

The read circuits use a mixture of proprietary MSI and LSI analogue IC's including VLSI analogue ASIC's, and standard high speed CMOS logic.

2.4.3.1 PE/GCR Densities

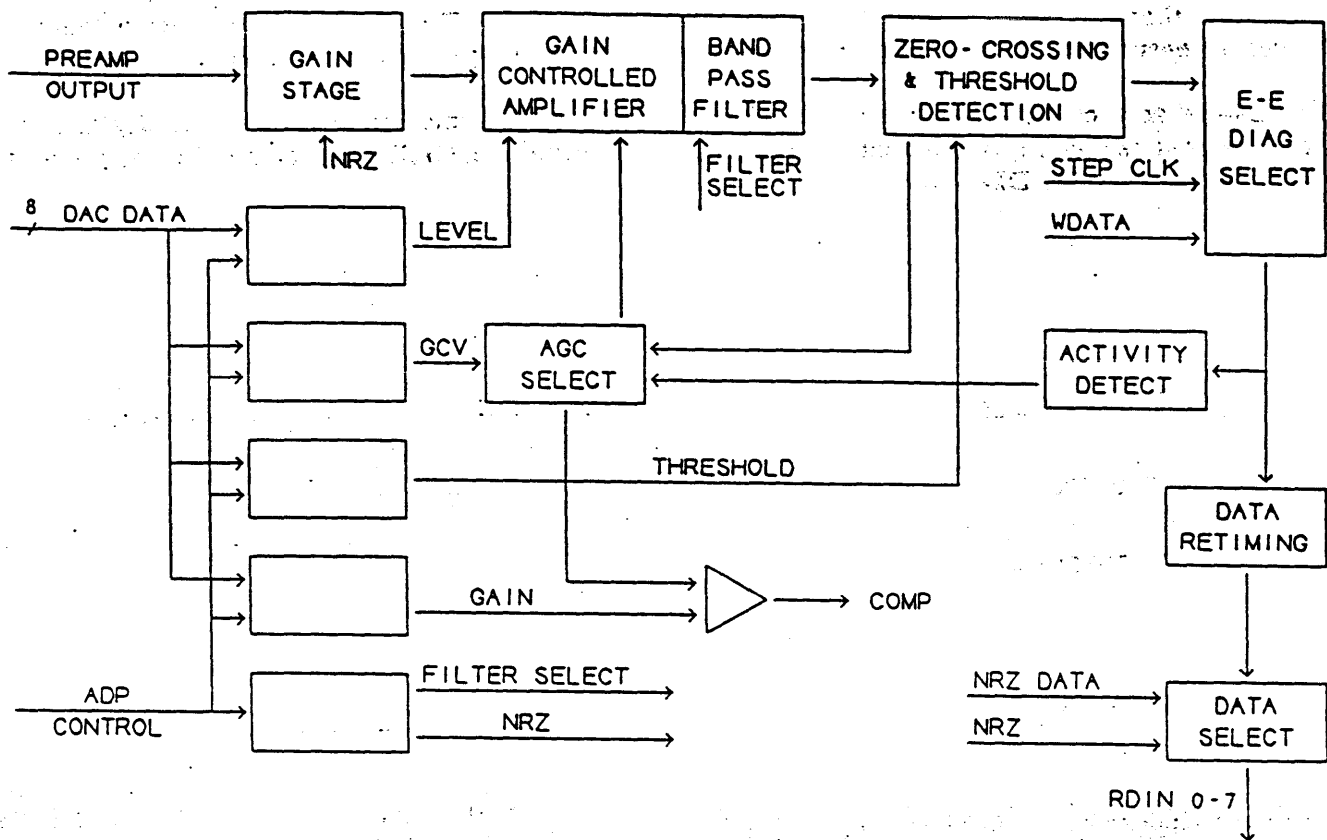

FIGURE 2.4.3.1(a) ADP READ BLOCK DIAGRAM - GCR/PE DENSITIES

The output from the pre-amplifier is taken to the first gain stage. This has a frequency response which can be altered depending on the mode of operation; in PE/GCR mode the response has gain increasing with frequency.

The first gain stage output is taken to a gain controlled amplifier (GCA). This has two operating conditions, under fixed gain and under AGC.

Under AGC, the output of the amplifier is set by the LEVEL signal, whereby the output amplitude is detected by the amplitude detector block and fed back through the AGC select block. The amplitude signal is compared with the LEVEL reference and an error signal produced which modifies the amplifier gain to stabilise the output amplitude. The presence of data at the output of the channel is sensed using the activity detect logic. This allows AGC to be selected only during data, preventing the amplifier from 'running away' during the IBG or when the tape is stationary.

Under fixed gain conditions, the amplitude input to the GCA is taken from a DAC and LEVEL is switched off. This allows the Data Control board to set the amplifier gain and hence the output level. The amplifier is used in fixed gain mode when writing (to ensure that the appropriate standards are met) and during the IBG.

The output from the GCA is band pass filtered. The filter characteristics required are speed and density dependant and one of four filters can be selected using the filter select lines. The filters themselves are tailored to a specific combination of speeds and densities, allowing the 9914 to be process data from 1600/3200/6250 bpi at speeds from 42 to 125 ips.

The filter output is processed to provide amplitude and zero crossing information. The zero crossing detector outputs a short pulse every time the filtered waveform passes through the zero signal level in either direction. The filtered signal is qualified against a threshold level set by the THRESH signal. This is a bi-directional threshold, requiring the signal to exceed the positive threshold before setting the output and then exceed the negative threshold before resetting. The zero crossing detector output is delayed to ensure the correct phase relationship with the threshold signal for GCR data recovery.

The delayed zero crossing and threshold detector outputs are retimed to recover the GCR/PE data. This is then output through a data selector which can select either PE/GCR data or NRZ data, giving the RDIN* signals for the DDP board.

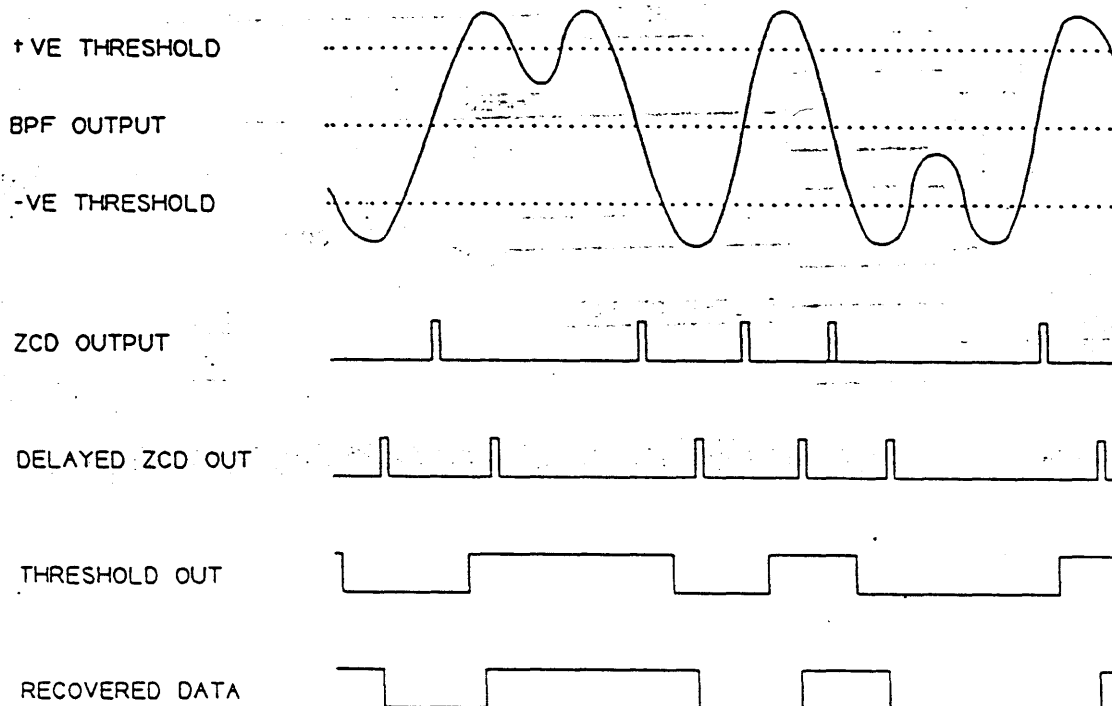

FIGURE 2.4.3.1(b) GCR/PE READ WAVEFORMS

2.4.3.2 NRZ Density

The output from the pre-amplifier is taken to the first gain stage. This has a frequency response which can be altered depending on the mode of operation; in NRZ mode the response is flat over the NRZ operating frequency range.

The first stage output is taken to the gain controlled amplifier. This is used in fixed gain mode under processor control, as described in 2.4.3.1 above. The GCA output is processed in two parallel paths. In one, the signal is band-pass filtered and the amplitude qualified using the threshold detector detailed in 2.4.3.1. In the second, the signal is separately band-pass filtered and then differentiated and the resultant zero crossings detected to extract the peak position information. The zero cross and threshold detector outputs are retimed to recover the NRZ data. This is then output through the data selector, giving the RDIN* signals for the DDP board.

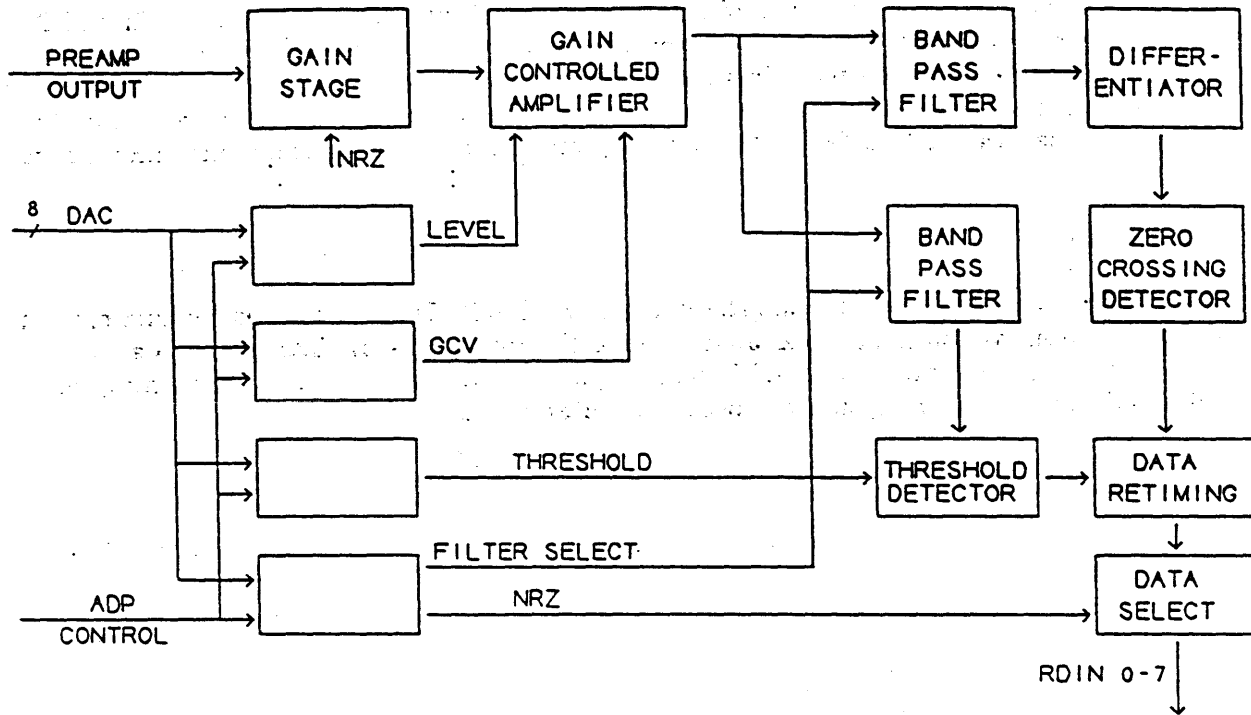

FIGURE 2.4.3.2(a) ADP READ BLOCK DIAGRAM - NRZ DENSITY

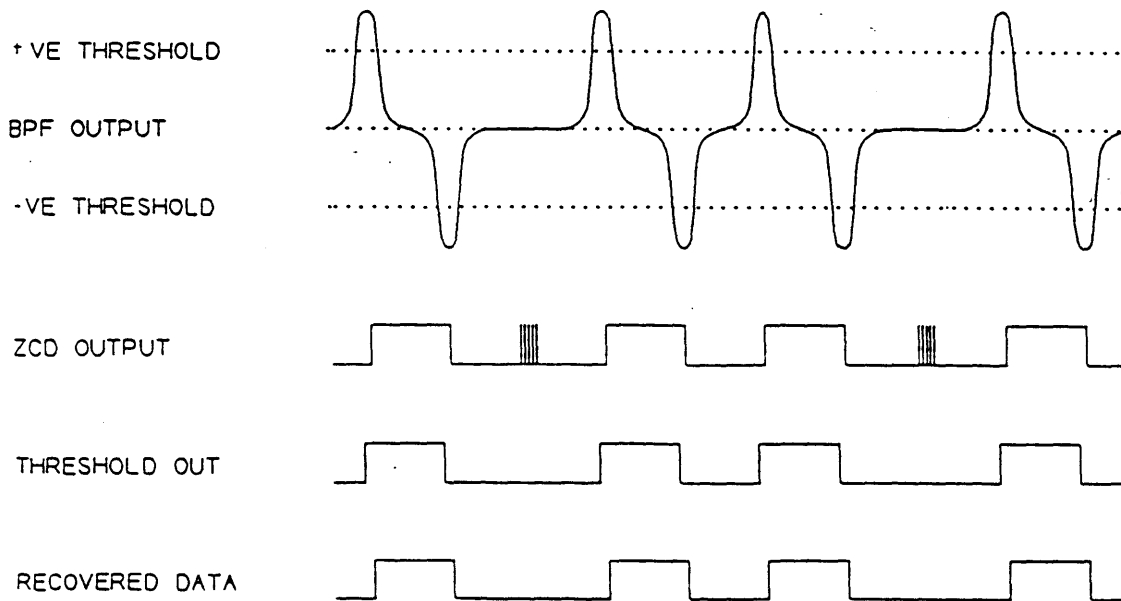

FIGURE 2.4.3.2(b) NRZ READ WAVEFORMS

2.4.4 E-E Mode

When the diagnostic programs require to check the data handling circuits, without corrupting data already on the tape, the E-E (electronics to electronics) mode of working is adopted. The LOOP signal (from the Data Control board) allows the zero crossing and threshold detector outputs to be replaced with STEP_CLK and WDATA respectively. This enables data checks to be made without energising the write circuits or moving tape. This tests the operation of the activity detect and the data retiming circuits; good or faulty data can thereby be fed to the decoding circuits in order to check that they function correctly.

2.4.4.2 Calibration

The amplitude signal and GCV can be monitored using the GAIN DAC output and comparator, this is used during calibration, which is outlined under diagnostic program 74 in Chapter 3. Various parameters, including pre-amplifier and ADP channel gains, write currents, and data timing are automatically calibrated, preferably using a dedicated reference tape.

2.5 DIGITAL DATA PATHS BOARD DESCRIPTION

CONTENTS

	<i>Page</i>
2.5.1 Overview	21
2.5.2 Initialisation	21
2.5.3 Write Data Transfers	21
2.5.4 Read Data Transfers	22
2.5.4.1 Read Control Strategy	22
2.5.4.2 Functional Blocks	22
2.5.5 Data and Strobe Signal pins	24
2.5.1 Overview	

This description applies to the DDP board, part number 121700, and the later p/n 123620.

Data from the Pertec interface (IWD0 - IWDP) is picked up by the DDP, to be encoded into the desired format and sent to the ADP to be written to tape.

When reading from tape, data from the ADP board is deskewed, decoded, checked for errors and corrected if necessary. The data is then gated onto the Pertec interface with an accompanying read strobe (IRSTR) for each data character.

The actions of the DDP board at any one time is controlled by the custom VLSI chips. This control can be split into three basic types of operation:

- . initialisation;
- . data transfers;
- . diagnostics.

2.5.2 Initialisation

The Write Control chip is notified of the recording density by the Data Control board, designated by analysis/default at switch-on, the configuration option setting by the operator, or interface command.

2.5.3 Write Data Transfers

2.5.3.1 Control Strategy

There are four chips which control and encode the write data, these are shown diagrammatically in Figure 2.5.3.1.

The initialisation or density change procedure sets up the Write Control chip and clears any registers for subsequent processing.

Data from the interface arrives at the input to the Write Encoder chip and is encoded according to the currently selected density. While the encoding method is relatively simple for NRZ and PE densities, at GCR density completely different principles are involved (the encoding is far more complex, and the one-for-one correspondence between data channel and tape track does not apply).

Appendix A contains an outline of the encoding (with respect to the DDP board) and the tape data format resulting from each density.

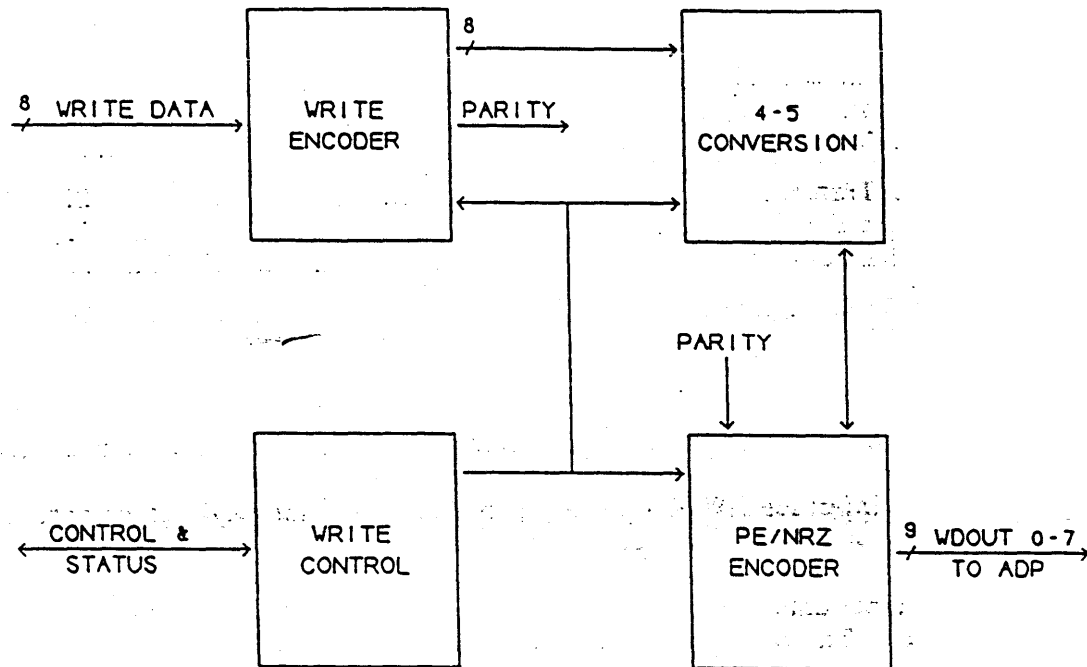

FIGURE 2.5.3.1 DDP WRITE BLOCK DIAGRAM

2.5.4 Read Data Transfers

2.5.4.1 Read Control Strategy

There are four sets of chips which decode and decipher the read data from the ADP board, these sets are shown diagrammatically in Figure 2.5.4.1.

The initialisation or density change procedure sets up the Read Control chip set and clears any registers for subsequent processing.

Data from the ADP board arrives at the input to the Clock Recovery and Deskew chip set and is decoded according to the currently selected density, notified to the Read Control chip set.

2.5.4.2 Functional Blocks

Clock Recovery & Deskew

The clock recovery circuit is based around the phase locked loop, which recovers the data rate clock from the incoming data.

Sync Detect circuits analyse the incoming data and generate the following states for use by the deskew control logic:

- . sync found;
- . data dropout;
- . dead track.

The deskewing system employs a first in first out (FIFO) buffer memory to buffer the channel data while deskewing is in progress. As a result of deskewing, the sync subgroups of all data channels are aligned and pass to the 5-4 Decode chip set.

5-4 Decode

Here the deskewed data is processed so that the tape byte characters are converted from the run length limited code back to data. Additionally the control subgroups are detected and track in error (TIE) pointers produced to any erroneous track(s), for use by the EDAC algorithm.

EDAC (Error Detection and Correction)

This includes a pattern generator, which creates the parity and error syndrome characters from the incoming data, for use in correcting data errors.

Overall the EDAC logic checks the CRC, Auxiliary CRC, padding and residual characters, in addition to controlling the error correction process, using the TIE pointers and syndrome characters.

Read Control

This chip set supervises and co-ordinates the operation of all the other chip sets.

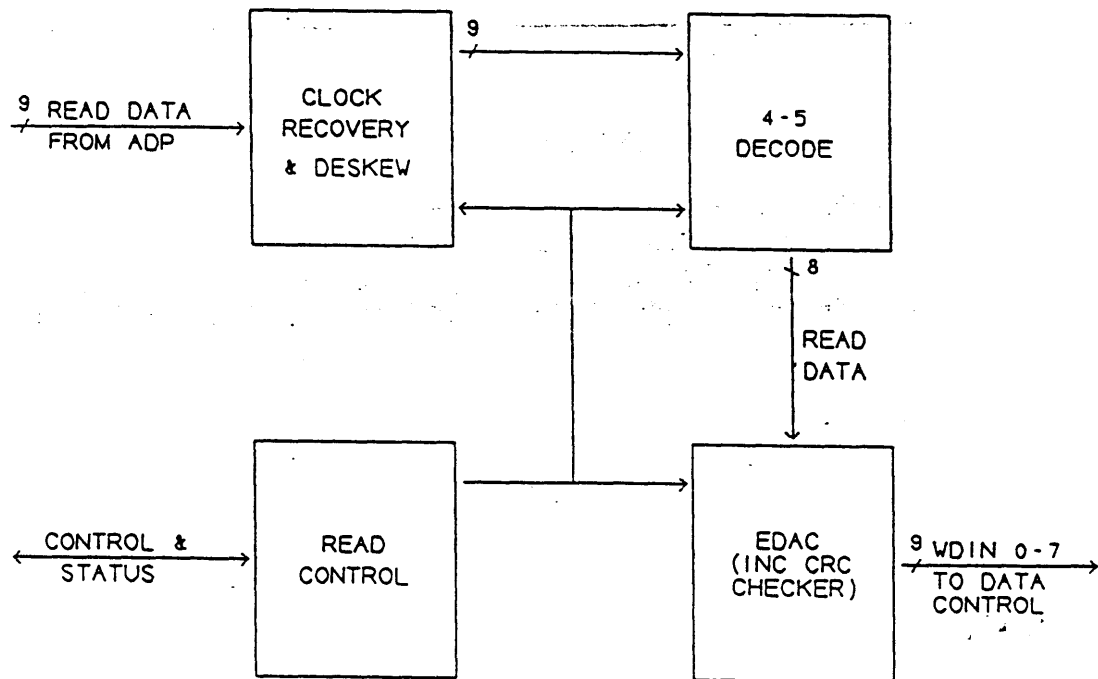

FIGURE 2.5.4.1 DDP READ BLOCK DIAGRAM

2.5.5 Data and Strobe Signal pins

Read data (and the 'write data strobe') appear on the following pins. The 'Pertec Pins' refer to the two interface connectors at the rear of the 9914.

Signal	Source	Edge Pin	Pertec Pin
IRD0		D1-19b	P2- 2
IRD1		D1-19a	P2- 3
IRD2		D1-18b	P1-48
IRD3		D1-18a	P1-50
IRD4		D1-17b	P2- 6
IRD5		D1-17a	P2-20
IRD6		D1-16b	P2-10
IRD7		D1-16a	P2- 8
IRDp		D1-15b	P2- 1
IRSTR		D1-14b	P2-34
IWSTR		D2-14b	P2-36

2.6 PRE-AMPLIFIER DESCRIPTION

This small pcb is situated within the tape path assembly and local to the head to minimise noise pick-up, hence avoiding degradation in the signal/noise ratio of the read data signals which are passed to the ADP board. It consists 9 wide-band low-noise amplifiers, whose gain is controlled in order to accommodate in excess of 40 dB dynamic range in the head output amplitudes. The amplifier gain (for each particular density and tape speed) is selected by the Data Control processor, via a latch and DAC, as the result of a previous calibration procedure for a particular tape. This philosophy eliminates the need for manual field setting of read parameters.

Read data channel activity at the pre-amplifier input consists of analogue signals varying from 1.5 mV (at 6250 bpi) to 50 mV (at 800 bpi). The read data signals are therefore best first investigated at the channel output test points, on the ADP board. These are amplified to a range of 50 mV (at 6250 bpi high speed) to 550 mV (at 1600 bpi low speed).

The read data signals are best first investigated at the channel output test points, on the ADP board, where the following voltage levels should be present. Note that the correct level does not in itself prove correct operation.

Density & Speed	Writing V pk-pk	Reading V pk-pk
NRZ Lo	1.4 - 1.8	1.4 - 1.8
NRZ Hi	1.4 - 1.8	1.4 - 1.8
PE Lo	1.4 - 1.8	1.6
PE Hi	1.4 - 1.8	1.6
DPE -	1.4 - 1.8	1.6
GCR Lo	1.4 - 1.8	1.6
GCR Hi	1.4 - 1.8	1.6

Power for the pre-amplifier board is derived from the ADP board and locally decoupled.

2.7 POWER SUPPLY DESCRIPTION

CONTENTS

	<i>Page</i>
2.7.1 Introduction	25
2.7.2 Power Supply Overview	25
2.7.3 +5 V Regulation	27
2.7.4 +12 V Regulation	27
2.7.5 -12 V, -6V, and -5V Regulation	27
2.7.6 +48 V Supply	27
2.7.7 +24 V Fan Supply	27
2.7.8 Auxiliary Circuits	28
2.7.9 Fault Finding	28

2.7.1 Introduction

The fuse locations, voltage rail availability points, and connector locations on the ac Power Supply board (part number 121590) are shown in Figure 2.7.2.

2.7.2 Power Supply Overview

The Power Supply board accepts inputs from the secondary windings of the 50/60 Hz mains transformer. A different input voltage setting is available for four possible input voltages:

100 V, 120 V, (4 A anti-surge supply fuse fitted);
220 V, 240 V. (2 A anti-surge supply fuse fitted).

The mains input is via an IEC 320 plug, Schaffner type FN376-6 (or equivalent), located at the rear of the 9914. This plug combines a power line filter, 1.25" fuse, and a voltage selector. The live line is taken through the supply fuse, then to the single pole switch (at the front of the 9914), and back to the voltage selector. Here a rotateable barrel engages contacts which set the mains transformer primary taps to correspond with the desired input setting. Selection of a particular input is described in Chapter 4 under 'Mains Transformer and Switch'. The present selection is visible in a window within the mains input moulding.

The transformer secondary windings enter the Power Supply board at the single multi-way connector P1, and are used to derive the following dc supplies:

Winding	Regulation	Output	Monitor point
0-18 V	buck	+5.2V ±2%	L6, C25 side
"	linear	+12.15V ±4%	C10, end nearer C7
0-35 V	none	+48V nominal	FS2, end nearer FS1
"	linear	+24V ±6%	FS5, end nearer P1
15-0-15 V	none	-18V nominal	<i>not used</i>
"	linear	-12V ±4%	C5, end nearer P1
"	linear	-6V ±5%	C14, end nearer P1
"	linear	-5V ±4%	C13, end nearer P1

The Power Supply board also contains ancillary circuits to provide a 50 kHz servo sync signal, and power-fail detection circuits.

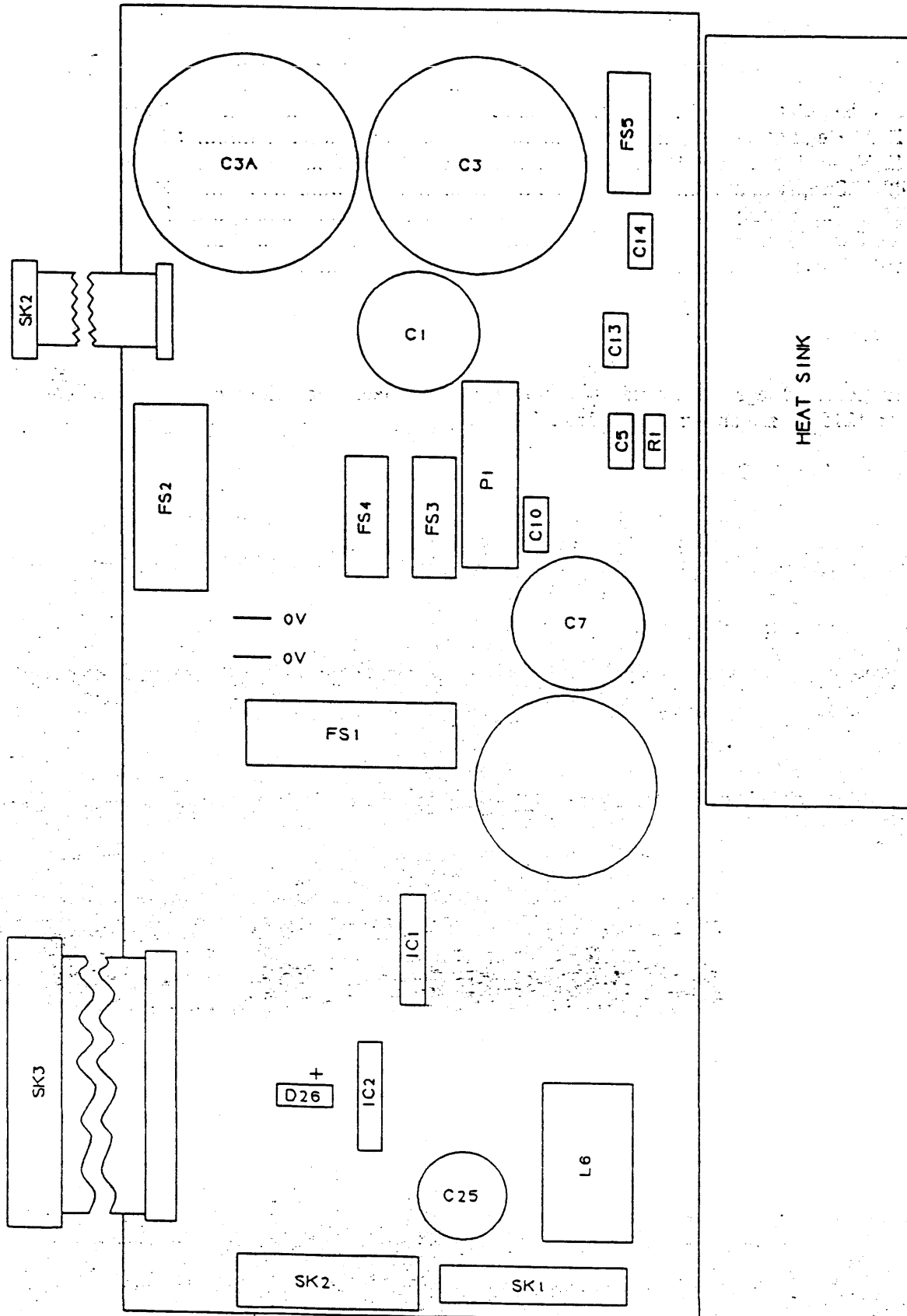

FIGURE 2.7.2 POWER SUPPLY ASSEMBLY

2.7.3 +5V Regulation

This is a step-down, or buck switching regulator controlled by IC2 (UC3524A). R24 and C21 set the oscillator frequency to 100 kHz, the regulator switching frequency.

The rectified output from D16 bridge is smoothed by inductor L5 before being pulse width modulated at 100 kHz and gives a resultant average output (+5.2 V nominal) after passing through a low pass filter comprising L6 and C25. Feedback from the output is taken from the R36/R37 junction and monitored by the error amplifier within IC2, the positive input of the error amplifier is fed with a stable DC reference signal from the junction of R21 & R22.

The output of the error amplifier is loop compensated by R20 & C18, enabling IC2 to track input voltage changes and load variations on the output to give excellent regulation of the output voltage and compensate for mains input variations from -15 to +10%.

Over-current protection is provided by a gate latch (resulting in IC1.8 going high), such that the supply is restored when the overload is removed, without blowing any fuses. Over-voltage protection is provided by firing an SCR (D17) which blows fuse FS1 and discharges the input capacitor C15.

2.7.4 +12V Regulation

The rectified output from D16 bridge is smoothed by C7 and then regulated by TR2 to give +12 V.

2.7.5 -12V, -6V, and -5V Regulation

The -12V, -6V, and -5V rails are derived from a centre-tapped winding, full wave rectified (by D2 & D3) and smoothed by C1 to produce approximately -18V dc (unregulated).

The -18V is regulated by TR1 to produce -12V (across C5), by TR4 to produce -5V across C13, and by TR5 to produce -6V across C14.

The transformer winding which supplies these rails is of light gauge, thus 3.0 A fuses F3 and F4 are included to provide protection against possible heavy fault currents which would not blow the mains input fuse without damaging this winding, thus meeting safety regulations. On no account should F3 or F4 be replaced with higher rated fuses.

2.7.6 +48V Supply

As this rail primarily supplies the servo motor power, no active regulation is incorporated, since the servo bridge contains a voltage feedforward circuit to compensate for supply changes. The 0-35 V winding is rectified by bridge D1 and smoothed by C3/C3A (in parallel) to give +48V, which is fused by FS2 (6.0 A - BUSS MTH6 is recommended).

The +48V rail is also used by the solenoid circuits, for increased current during initial pull-in.

2.7.7 +24V Fan Supply

The main function of this rail is to provide sufficient regulation and power for a consistent loading fan performance against incoming mains variations. The cooling fan is also driven from this rail.

The +24V output is derived from the +48V rail, by a simple linear regulator circuit which utilises a high power Darlington (TR3), and D11 (24V) as a reference. Short-circuit protection is provided by FS5 (2.0 A BUSS GMA2 is recommended). The loading fan typically draws 1.6 A, and the typical loading fan on-time is 10 seconds. If the loading fan were to stall, FS5 is designed to blow.

2.7.8 Auxiliary Circuits

These include a rail sensing network for the +/-12V, +48V, and +5V outputs, which produces a logic high condition at TR18-C (& SK4/5) if any supply develops an under-voltage condition.

IC3 takes the oscillator output pulses from IC2.5 and generates bi-phase 50 kHz square waves at pins 12 & 13 for Servo Control board (to synchronise the servo output stage and the +5V regulator).

The cooling fan has current sensing provided by R54 & R55 in series, driving TR19 on via R56 & C28. The 9914 power-up sequence looks to see if TR19-C is low (correct fan current present). If the fan is stalled, the fan internal protection mechanism will present a high impedance after a short period, causing TR19-C to go high (if the fan is disconnected, TR19-C will also go high). TR19-C output is the designated PWR_FAIL signal to the ADC on the Servo Control board, it is only monitored during the power-up sequence, by the servo control firmware.

2.7.9 Fault Finding

Symptom(s)	Investigation/remedy
9914 dead, no display & no fan noise & no transformer hum.	Check mains input fuse, and voltage selection, against available supply. See User/Diagnostic Manual, if re-selecting.
9914 alive but unwell, display functional.	Run diagnostic program 73, if pass but '*Power' displayed, +48V may be faulty.
FS1 blown.	Check D17 & D25 cathode-anode, & TR11 drain-source, if ok: set SW1 to position 1, replace FS1, switch on, check 22V at IC2.15, check +5V at IC2.16, check 100 kHz (0.5 us pulses) at IC2.3, check 100 kHz (22V pk) at IC2.12 & .13, if ok: power off, set SW1 to position 2, power on; if ok, short circuit or injected transient caused fault.
FS2 blown.	Servo malfunction, eg MOSFET output stage short circuit, (use diode checker to test D-S & G-S impedances).
FS3/4 blown.	Short circuit across 15-0-15 winding.
FS5 blown.	Short circuit or stalled loading fan. Breakdown of +24V regulator.

2.8 SCSI INTERFACE BOARD DESCRIPTION

This board artwork accommodates various amounts of RAM, the following description applies to part numbers from 121972 through to 121975, and to part numbers from 123508 through to 123513.

The SCSI Command Set is described in the 9914 SCSI User Manual.

2.8.1 General

The SCSI Interface board allows the 9914 to be connected as a Target on the Small Computer Systems Interface (SCSI). It is a micro-processor based design, with the processor/firmware exerting control over the various hardware elements, and interpreting/executing the SCSI commands. The commands supported, their detailed operation, and the signal pin allocations, are given in the 9914 SCSI User Manual.

The design is based around the NEC uPD70208 (V40) high integration micro-processor, incorporating a 16-bit processor, DMA controller, interrupt controller, timer/counter section, and a DRAM refresh control unit. The hardware design is further minimised by use of the NCR 53C90A SCSI Controller chip. This 3rd generation, high performance LSI device carries out the detailed control of the SCSI interface lines and performs all of the SCSI bus management functions.

The main elements of the board are shown in Figure 2.8.1, and discussed in Section 2.8.2 onwards.

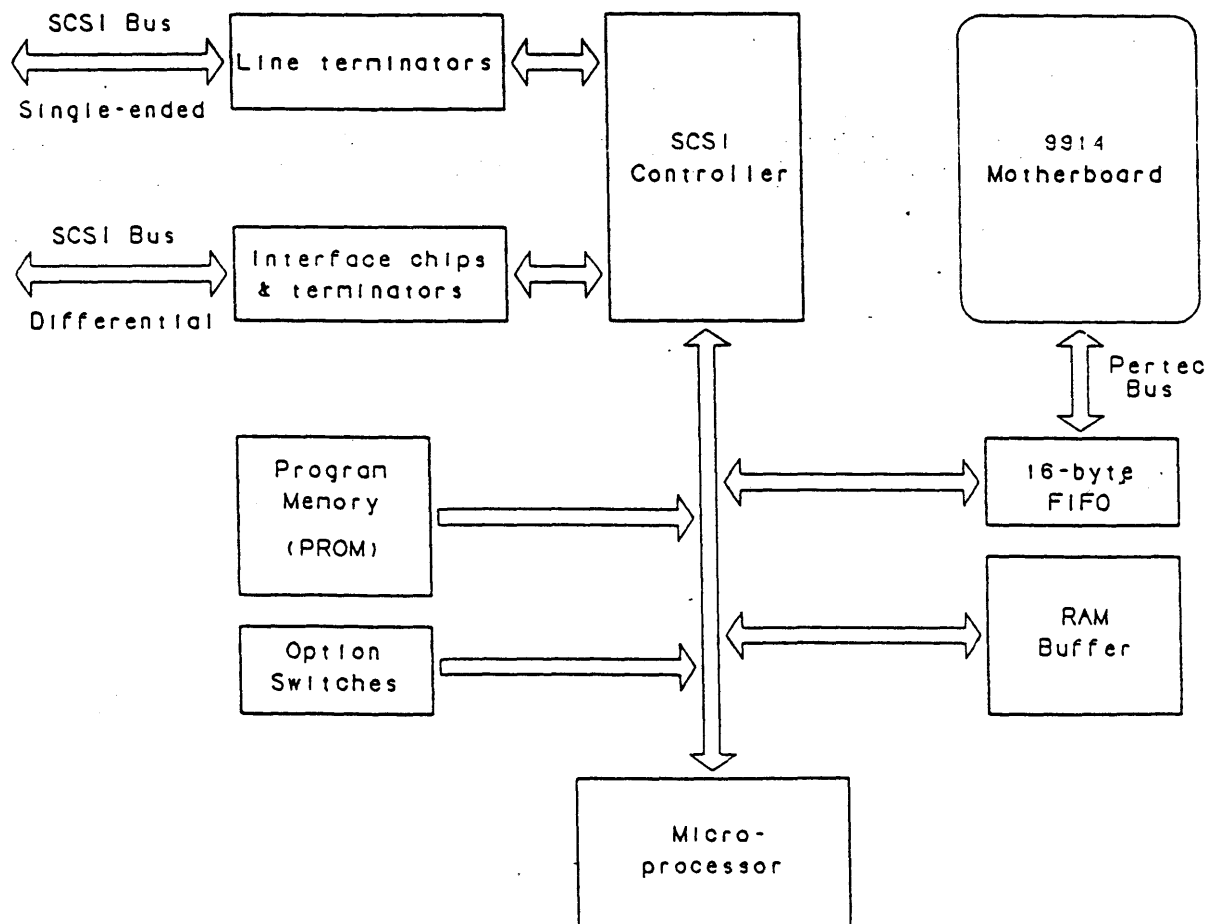

FIGURE 2.8.1 SCSI CONTROLLER

2.8.2 Micro-processor Circuits

The Processor

The NEC V40 contains a 16-bit processor, but interfaces to external peripherals and memory via an 8-bit data bus. The processor has a 20-bit address bus giving a 1 Mbyte address space. No memory paging is employed on the board, and the processor (and DMA channels) directly addresses 750 Kbytes of ram and 250 Kbytes of program memory.

The processor is run at 8 MHz from a 16 MHz clock provided by an external oscillator based around a 7404 inverter and quartz crystal.

All data transfers within the board are carried out on the processor's main data bus which has a bandwidth of 2 MB/s. This is shared between processor, DMA and refresh cycles.

The Memory

Programme memory is provided by a 256K EPROM. Processor stack and general RAM registers are resident in the first 3k of the RAM buffer, with the remainder of the 750k RAM providing data buffer storage when writing and reading to and from tape.

The RAM is designed using Dynamic Ram devices to give the required total.

The 9th bit of the RAM is used to provide a parity check on the buffered data; every data byte written into the RAM generates a corresponding parity bit which is stored with the byte. This is then used to provide the external parity bit on the tape unit interface, giving a parity integrity check throughout the RAM storage period and onto tape.

The processor provides a refresh control unit. This is pre-programmed to provide an average of 256 refresh cycles every 4 ms.

The DMA Channels

The processor provides a sophisticated 4-channel DMA controller. Channels 0 and 1 are used to control tape unit transfers, while channel 3 controls transfers to and from the SCSI controller chip; channel 4 is unused.

Each channel is fully independent, allowing 'simultaneous' transfers between the data buffer and tape interface, and the data buffer and SCSI controller. The channels are programmed to transfer in single cycle, burst or demand mode as required by the different SCSI commands being executed.

The various data buffering modes are described in the SCSI User Manual, under each relevant command.

Channels 0 and 1 are essentially or-ed together; channel 0 is used for all normal write/read operations to/from the tape, ie where the size of the transfer is no greater than 64K. They are used together in a special interleaved action when block lengths greater than 64K have to be written or read.

The Interrupt Controller

The processor's interrupt controller is programmed for rising edge operation and is used primarily by the SCSI controller to signify the end of the current operation, and similarly by the tape unit via the TDBY line.

The SCSI Controller

The SCSI controller used is the NCR 53C90A, a high performance device which can carry out various SCSI bus related sequences autonomously without processor intervention. Thus, following a single byte command from the processor, it will respond to selection on the SCSI bus, transfer the Identify message, transfer the first byte of the Command Descriptor Block, check which group the command belongs to, then transfer the appropriate number of command bytes before signalling completion to the processor via an interrupt.

The chip is connected to the processor as an I/O device, and can transfer data directly to/from the data buffer under DMA control. All SCSI command, status and message bytes are transferred under programme control, while all SCSI data phase bytes are transferred directly to/from the data buffer.

An on-board 16-byte FIFO simplifies and improves the interfacing between the SCSI bus and the internal data bus. A maximum burst rate in excess of 3 MB/s can be supported on the SCSI bus, although the maximum sustained average rate is limited to 2 MB/s. This will drop further to around 1.2 MB/s if simultaneous tape transfers are taking place.

The Physical Interface

The ANSI SCSI specification allows for 2 possible electrical interfaces, viz. Single-ended or Differential. The SCSI interface board artwork supports both options, but is designed to be supplied to the customer as either one or the other.

In single-ended mode, the SCSI controller connects directly onto the SCSI bus; the chip itself contains the necessary 48 mA driver receivers.

In differential mode, the various SCSI signals are routed via 75176 differential transceiver chips.

On-board terminating resistors (socketed) are provided in both modes.

TERM PWR is provided in both modes via a diode and 1.5 Ampere fuse.

The DIFFSENS signal is utilised to avoid damage if the differential board is connected to a single-ended bus.

The Tape Interface

The SCSI board controls the tape unit via the unit's normal Pertec interface. A full description of the 9914 Pertec interface can be found in the 9914 Product Specification.

A 16-byte FIFO is utilised on both the write and read data paths to and from the tape unit. This ensures that data is always available for, or can always be accepted from, the unit's synchronous data interface. It also improves DMA efficiency by allowing the DMA channel to burst data at high speed between the FIFOs and the data buffer.

The 9th parity bit of the data buffer is provided to the tape unit as the parity bit (odd) of the Pertec Write Data bus.

In-coming read data from the unit (8 bits & parity) is always checked for correct parity before transferring to the buffer.

This page has no technical content.

CHAPTER 3 - FAULTS, CALIBRATION, AND CONFIGURATION

CONTENTS

	<i>Page</i>
3.1	SCOPE OF CHAPTER 3 1
3.2	STARTUP 1
3.2.1	Power-on Self-check 4
3.2.1.1	Stuck Legends 7
3.2.2	Voltage Rail Failure 10
3.2.3	Loading indications 10
3.2.3	On-line indications 12
3.3	DIAGNOSTIC PROGRAM ERROR CODES 13
3.4	COMMON ERROR CODES 19
3.5	DIAGNOSTIC PROGRAM DESCRIPTIONS 21
3.6	ADDITIONAL FAULT FINDING IDEAS 41
3.7	MANUAL TAPE LOADING 47
3.8	AZIMUTH CHECKING/SETTING 47
3.9	TAPE TENSION CHECKING/SETTING 48
3.10	TAPE SPEED CHECKING 48
3.11	RE-CALIBRATION 49
3.12	CONFIGURABLE OPTIONS 50
3.13	FULL STATUS BYTES 71
3.14	CONDENSED STATUS BYTES 80

3.1 SCOPE OF CHAPTER 3

This Chapter contains instructions to enable a trained engineer to diagnose faults in the 9914 Streamer. The information provided is designed to locate the more common faults and act as a diagnostic aid to finding difficult faults.

A list of service tools and specific sub-assembly servicing information is set out in Chapter 4.

The earlier sections deal with straightforward faults while Section 3.6 deals with more obscure faults.

3.1.1 Interlock Override

When the diagnostic mode is entered the interlocks are still effective. If the tape path cover is opened (eg to examine the tape path) tape motions ceases as part of the normal safety facility.

In order to run tape motion programs with the tape path cover raised it is necessary to run diagnostic program 95, which constitutes interlock override. Tape motion is then enabled until such time as the tape path cover is closed again and the front right thumb-screw fastener secured.

WARNING:
PERSONAL INJURY CAN BE CAUSED BY TOUCHING TAPE PATH COMPONENTS
WHILE THE TAPE IS TENSIONED.

3.2 STARTUP

Two flowcharts are provided to assist when first approaching the 9914. Figure 3.2(a) sets out various procedures to achieve broad objectives while Figure 3.2(b) sets out the sequence of events immediately after power is applied to the unit.

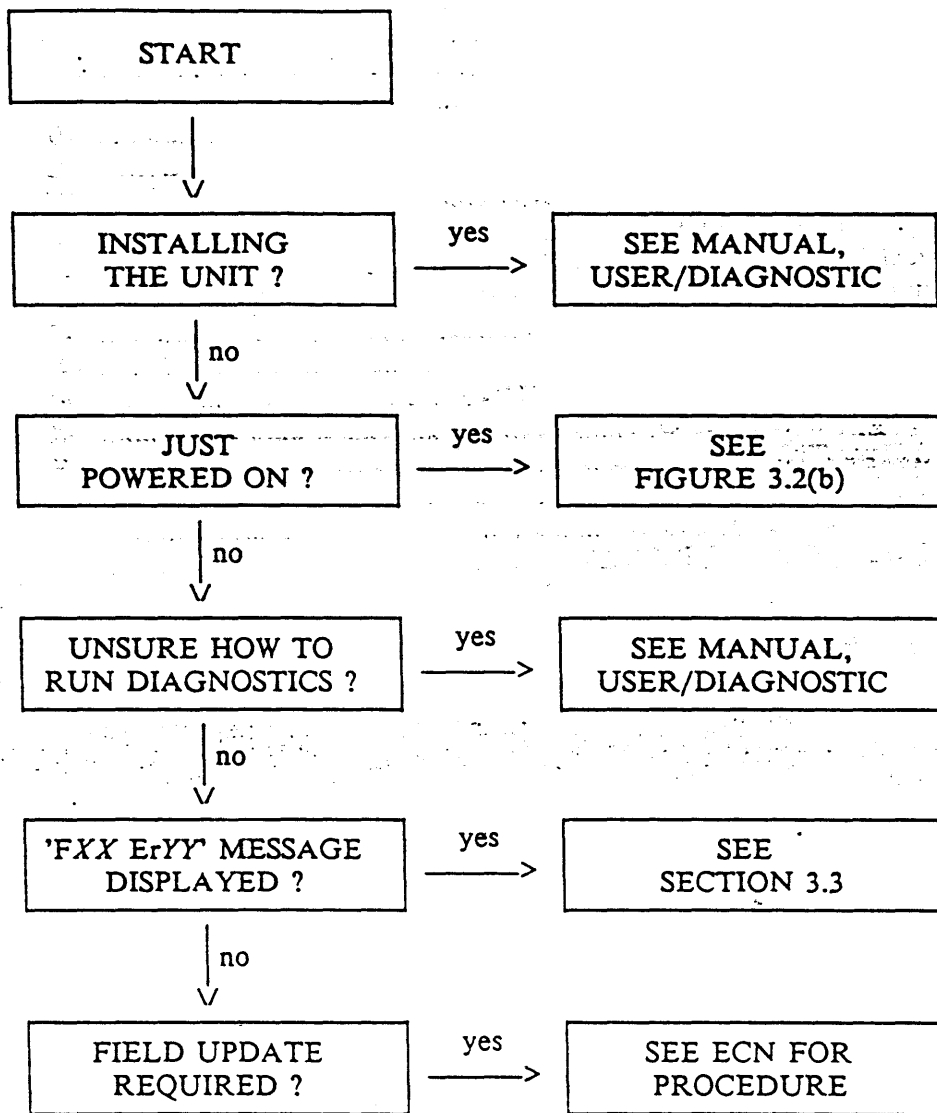

FIGURE 3.2(a) 9914 PROCEDURES

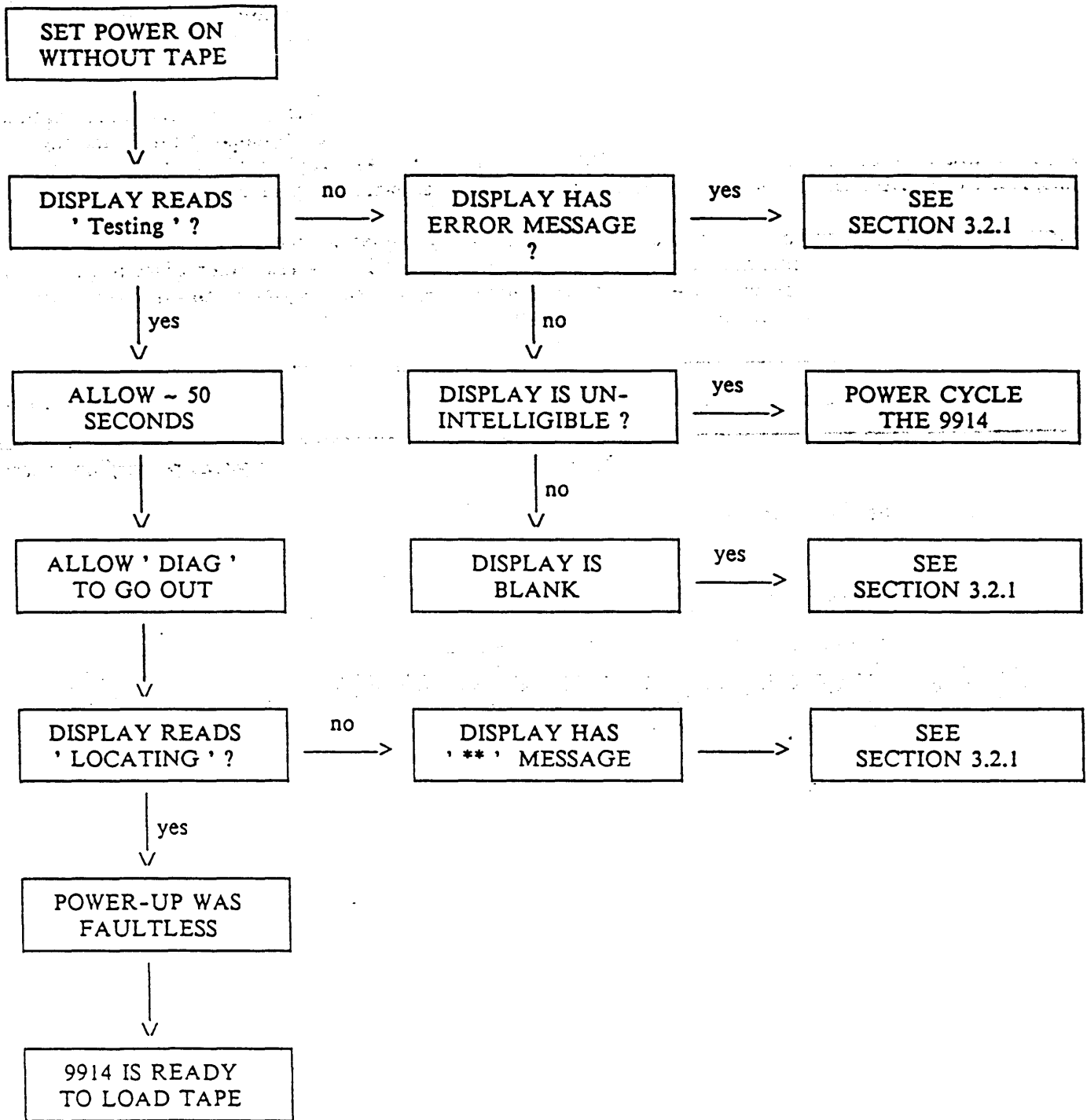

FIGURE 3.2(b) 9914 POWER-ON FLOWCHART

3.2.1 Power-on Self-check

A self-check routine of critical power rails, firmware compatibility, and connector validation is automatically initiated when power is applied to the 9914, the following is a list of the indications which may appear on the 8-character display, during or after this health check.

The suggested remedies and suspect FRU's are listed with each fault message; the FRU abbreviations are listed in Section 3.3. Attention should be paid to the fault history; if an 'incompatibility' message appears, this may be the result of board or PROM substitution. Any fault could be a connector misplaced or a cable fault, the internal interconnections are shown in Figure 3.2.1.

Most fault indications which are preceded by '**' may be by-passed up to the point where a tape is loaded and/or diagnostic programs are run. The by-pass method is to press either LD/ONL or to press RESET and DENSITY together). By-passing only enables further investigation, the fault cause must be eliminated before the 9914 can be put into on-line use.

Message	Explanation, causes, and remedies	Suspect FRU
<i>blank display</i>	Mains power is not available, or the +5V supply is not present, or Servo Control P5 is disconnected, or the Servo Control ~ Data Control bus is faulty. Remedies: check mains input fuse, check PSU fuse (FS2 - 6.0 A), check the Servo Control led is illuminated. check that Servo Control connector P5 is plugged in.	Mains power/input fuse PS/SC/DC
** ADP	The Analogue Data Paths board is missing, or motherboard fault.	ADP/DC
** ADP1	The COMP lines between the ADP board and the Data Control board are faulty.	ADP/DC
** ADP2	The WTNG signal is faulty.	ADP/DDP/DC
** ARM	The output voltage from the tension arm position sensor was well outside limits. Remedy: run diagnostic program 47.	SC/TPA
** BIFF	The buffered interface (SCSI or PCI board) is not responding, but option byte 13 (bit 6) set to indicate it is present. Remedy: if SCSI (PCI) board just removed, replace it, substitute SCSI (PCI) board, substitute Data Control board. Note: early 9914's indicate ** SCSI for this fault.	DDP/SCSI/PCI/DC
** BOT	Servo Control board has completed loading the tape but the Data Control board is unable to confirm BOT.	SC/DC
** CHUTE	Unexpected output from in-chute Rx. Cause: excessive light falling on Rx; Servo Control board fault, sensor fault.	TPA/SC
** CONF	Unable to configure the DDP. Remedy: exchange the DDP board.	DDP/DC

Message	Explanation, causes, and remedies	Suspect FRU
CON VAL 1	Data Control board missing, <i>or</i> motherboard disconnected (Servo Control P4).	SC/DC
CON VAL 2	Reel motor disconnected, P1 or P2.	SC
CON VAL 3	Tape path loom disconnected, P6, <i>or</i> tension sensor disconnected, PL AL, <i>or</i> BOT/EOT sensor disconnected, SK EB.	SC
CON VAL 4	Loading fan disconnected, P3.	SC
CON VAL 5	Auxiliary PSU cable disconnected, P8.	
CON VAL 6	Door solenoid disconnected, PL2. <i>- or Display panel</i>	SC/SF
CON VAL 7	Hub solenoid disconnected, PL HS. Note: signal travels via in-chute sensor board, see Figure 3.2.1.	SC/TPA
** DCom	Data Communication - Data Control board cannot communicate properly with the SCSI board.	SCSI/DC
** DDP	The Digital Data Paths board is missing, <i>or</i> Data Control board fault, motherboard fault.	DDP/DC
** DDP1	The EEPROM lines are faulty.	DDP/DC/ADP
** DDP2	The Data Control 'reset' is faulty.	DDP/DC
** DN1	No densities available. Remedies: connector/cable fault, density configuration options all 0, exchange the DDP board, exchange the Data Control board.	DDP/DC
** DN2	Default density not available. Remedies: similar to **DN1.	DDP/DC
** DP1	DDP PROMS are missing, <i>or</i> wrong PROM fitted in location IC9, Data Control board, <i>or</i> DDP board just exchanged.	DC/DDP
** DP2	DDP PROMS are incompatible, <i>or</i> wrong PROM fitted in location IC10, Data Control board.	DC
** DRAM	Data Control processor not functioning, <i>or</i> Data Control RAM not functioning, <i>or</i> Servo and Data control not communicating, <i>or</i> motherboard or cable fault; possibly the ADP board holding a signal.	ADP/DC/SC/PS
** DROM	A malfunction was found in the Data Control PROM, ie its checksum was incorrect. Remedies: if PROM recently inserted, check lead integrity, <i>or</i> if PROM type substituted, check access times is less than 200 ns.	DC
** DPROC	Servo Control board getting no response from the Data Control board.	SC/DC

Message	Explanation, causes, and remedies	Suspect FRU
	<i>o mal motor o mal servo</i>	
** FAN	Current not detected in cooling fan.	C Fan/SC
** FAULT	An earlier *** fault message was by-passed, and an attempt is now being made to place the 9914 on-line. ** FAULT persists for 5 seconds before the display reverts to its former message. Remedy: power cycle to regenerate earlier message.	Op
** HEAD	Write head disconnected, cable fault, or ADP board fault.	ADP/DC
** LIMIT	Tension arm limit not detected at power-on.	TPA/SC
LOST	Handshaking between the Servo Control board and the Data Control board began but the message transfer was not completed. Remedies: check for connector/cable fault, substitute Servo Control board, substitute Data Control board, substitute motherboard.	DC/SC
** NVR	Data Control board battery exhausted or missing, or partial data RAM failure, or first time power-on (press LD/ONL to re-load the NVR, re-calibrate the 9914 before using on-line) possible fault on Data Control, ADP or DDP board.	DC/Op
OK	The power-up checks have been successfully completed.	
** P AMP	Pre-amplifier disconnected, or ADP fault, or cable fault.	DC/ADP/TPA
** PR1	Data Control PROMS incompatible with the Servo Control PROMS.	
** PR2	SCSI (or PCI) PROMS incompatible with the Data Control PROMS, or SCSI bus not terminated (eg 9914 removed from a system)	DC/SCSI/PCI/DDP
POWER	A fault was found while the presence of the internal power supply lines was being checked, this may be the Power Supply board itself or a 'power fail' circuit fault. Remedy: press LD/ONL and run diagnostic program 73, check the actual Power Supply output voltages, see Chapter 4. Check the 'power fail' circuit on the Power Supply board.	PS/DC/SC
** RAM	A malfunction was found in the Servo Control RAM area while all ones, all zeros, and chequerboard patterns were written to and read from the RAM to ensure correct operation.	SC
** SComX	Servo Communication - Servo Control board cannot communicate properly with the Data Control board.	DC/SC

6572917

Message	Explanation, causes, and remedies	Suspect FRU
** SCSI	SCSI (or PCI) board not responding, but option byte 13 (bit 6) set to indicate it is present. Remedy: if board just removed, replace it, substitute board, substitute Data Control board.	SCSI/PCI/DC
** SPRING	The tension arm was found not to produce any tension. Remedies: check the spring is connected, run diagnostic program 47.	TPA
** SROM	A malfunction was found in the Servo Control PROM, ie its checksum was incorrect. Remedies: if PROM recently inserted, check lead integrity, or if PROM type substituted, check access time is less than 200 ns.	SC
* TENS 1	Sufficient SU motor current was applied to move the tension arm outside the limit flag, but the arm remained at its limit. Remedies: check the tension arm is not obstructed; run diagnostic program 45, check the sensors; substitute the Servo Control board.	TPA/SC
* TENS 2	Sufficient SU motor current was applied to bring the tension arm to centre travel, but it did not reach the centre. Remedy: check the tension arm is not obstructed.	TPA/SC
TESTING	The power-on checks are still in progress.	

After successful completion of the power-on tests, the display usually shows 'LOCATING', while the firmware is attempting to centralise the tape reel. Exceptionally the display shows 'OK', if the auto load feature has been disabled (configuration option 04). 'DOOR/LID OPEN' may appear if the loading door/tape path cover is not securely closed.

3.2.1.1 Stuck Legends

Faults may occur where a legend is stuck, eg a 'WT EN' illuminated from immediately after power-on. Stuck faults are listed here. Program 72 is provided to check out the displays.

Legend	Fault type	Suspect FRU
ONLINE	Always illuminated	SC/SF
	Never illuminated	SC/SF
DIAG	Always illuminated	SC/SF
	Never illuminated	SC/SF
WT EN	Always illuminated	SC/SF
	Never illuminated	SC/SF
EOT	Always illuminated	SC/SF
	Never illuminated	SC/SF

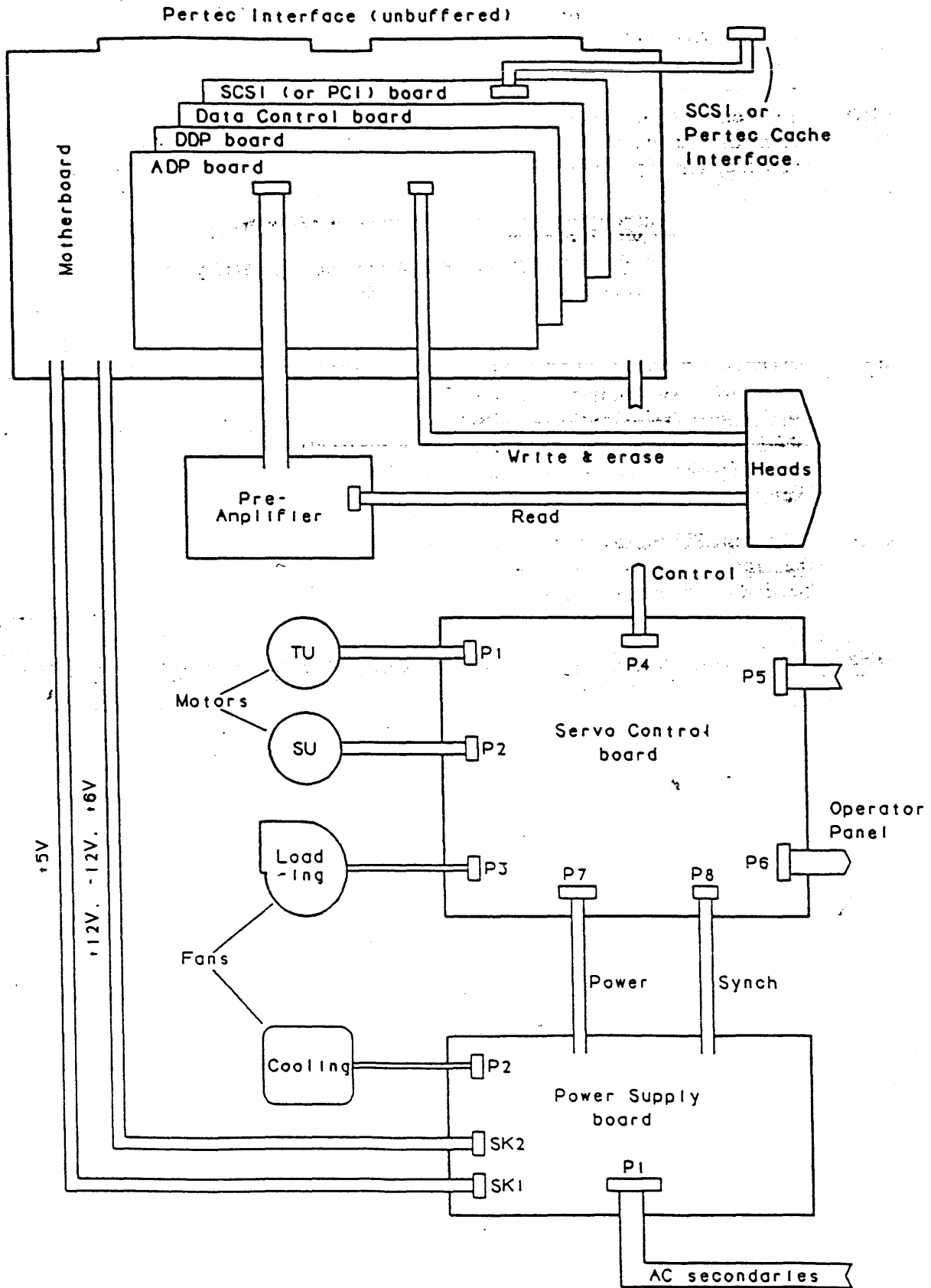

FIGURE 3.2.1 (a) INTERCONNECTIONS

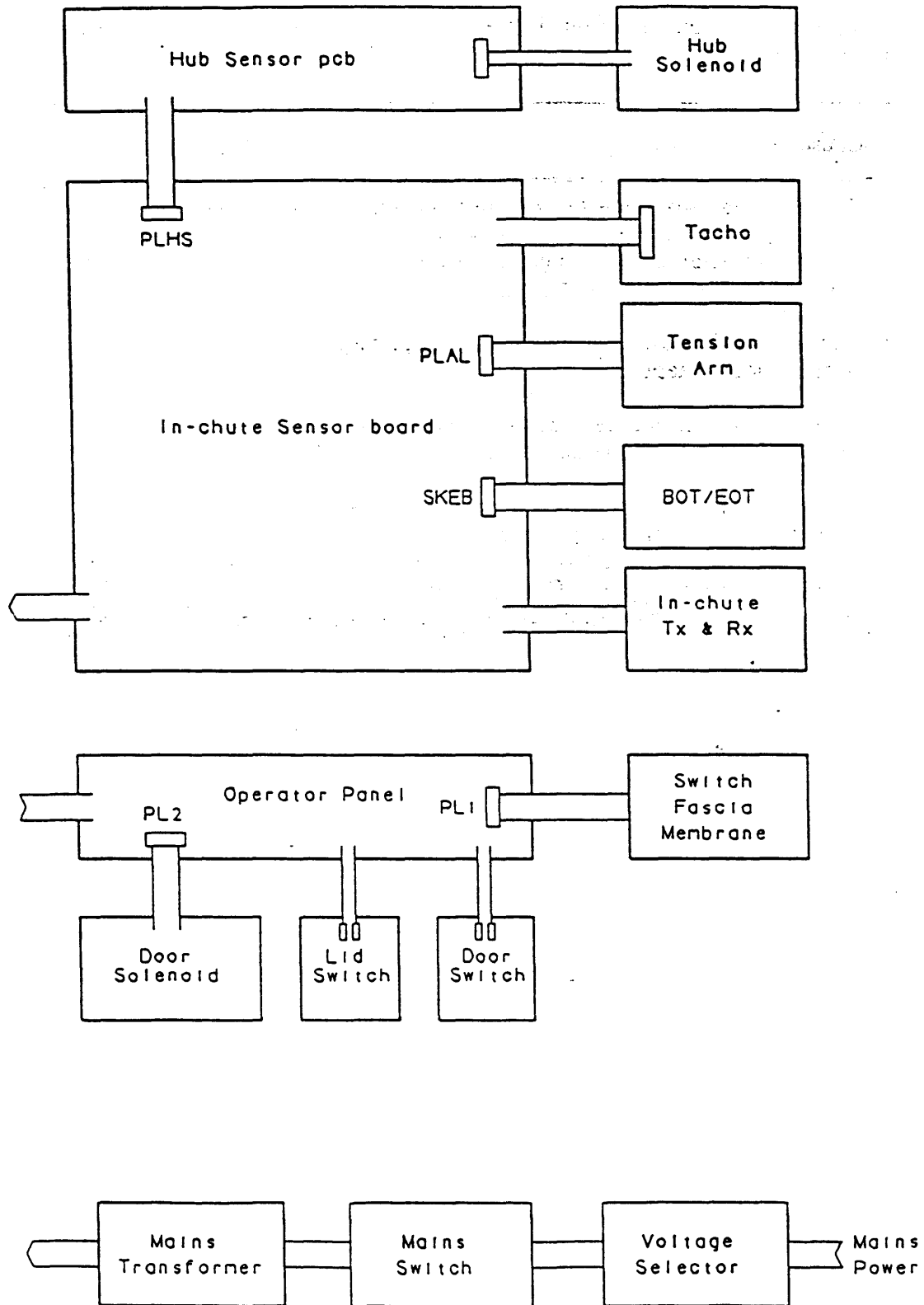

FIGURE 3.2.1 (b) INTERCONNECTIONS

3.2.2 Voltage Rail Failure

Power fail checks are run from time to time, after completion of the power-on checks. If a failure is detected, the POWER message is displayed and further operation is prevented.

3.2.3 Loading Indications

The full list of loading indications is set out in the 9914 User/Diagnostic Manual; the indications which require attention are listed here.

Indication	Cause	Suspect FRU
** BOT	The BOT tab was detected before tape entered the tape path. Remedy: run diagnostic program 45 and check operation of BOT detector circuit; check operation of Servo Control board.	TPA/SC
OK	Power-up diagnostics are successfully completed. Action: load a tape.	
DOOR	Loading has commenced, but the loading door is not correctly closed. Remedy: close the tape loading door.	Op
** EOT	The EOT tab was detected before tape entered the tape path. Remedy: run diagnostic program 45 and check operation of EOT detector circuit; check operation of Servo Control board.	TPA/SC
HUB ERR 1	The tape reel has not been confirmed as fully seated on the supply hub, because the firmware has concluded that only one 'located' flag was present. Remedy: re-load, or centre the reel before initiating load; persistent 'err 1' could indicate damaged 'located' flags, or the supply hub adjusted too high. Run diagnostic program 45 to check that 3 flags per revolution are detected.	TPA
HUB ERR 2	The tape reel has not been confirmed as fully seated on the supply hub, because the firmware has concluded that only two 'located' flags were present. Remedy: re-load, or centre the reel before initiating load; persistent 'err 2' could indicate a damaged 'located' flag or the supply hub adjusted too high. Run diagnostic program 45 to check that 3 flags per revolution are detected.	TPA
* HUB SOL	The hub lock solenoid has been driven but the activity of the 'located' flag was not consistent with successful clamping. Remedies: run diagnostic program 45, check the mechanical action of the clamping mechanism as described in Chapter 4 under Supply Hub, if ok, trace the 'located' signal, which travels to the Servo Control board via the in-chute sensor board.	TPA/SC
IN LIMIT	Tape tension has been lost (the tension arm has reached the limit of its travel), Remedies: run diagnostic program 47 to check the tension arm position and limit circuits; substitute the Servo Control board.	TPA/SC

Indication	Cause	Suspect FRU
LID OPEN	Loading has commenced, but the tape path cover is not fully secured. Remedies: check that all three thumb-screw fasteners are tightened down; check operation of tape path cover microswitch.	Op/SF/SC
N I C	Not In Chute; tape was not detected in the tape path chute, Remedies: the tape end may not be leaving the bulk, remove any foam pad), check that the loading fan is operational, run diagnostic program 45 to check the 'in-chute' circuit.	L Fan/TPA
NO TAPE	The reel locating circuits did not detect a tape reel on the supply hub. Remedies: insert a reel before initiating load; check the SU reel motor rotates; run diagnostic program 45 to check the 'located' flags; substitute the Servo Control board.	TPA/SC
N T U	Tape was not gripped onto the take-up spool. Remedies: check that the TU spool does turn at take-up time, power may not be present at the motor; check that the tape end is not severely damaged, crop if damaged and try again, run diagnostic program 47 to check the tension arm position signal is correctly generated and correctly sensed by the Servo Control board; if the take-up hub height has been recently altered, watch for contact between tape and a flange, check the hub height setting.	<i>Possible gema en el Rollet del tachometer</i> tape/PS/TPA
REEL INV	The tape reel was found to be inserted with the 'write enable' ring on the top side of the reel. Remedies: re-insert the reel, with the 'write enable' ring side down; check operation of in-chute sensor (diagnostic program 45); check operation of Servo Control board.	Op/TPA/SC
RESET	During the loading sequence, the RESET button was sensed as being permanently depressed. Action: verify the reset signal at the Servo Control board.	SF/SC
** TAB	The BOT tab was not detected near the end of the loading sequence. Remedies: check a tab is present, within ANSI/ECMA distances from the physical end; check operation of BOT detector circuit (diagnostic program 45); check operation of Servo Control board.	tape/TPA/SC
UNLOAD then UNLOCK	The BOT marker could not be detected. Remedy: load a different tape, to confirm the detection circuits are functional, check that the marker is present, not too far down the tape.	

3.2.4 On-line Indications

The full list of on-line indications is set out in the 9914 User/Diagnostic Manual; the indications which suggest fault conditions are listed here.

Blank	A forward 'read' or 'space' interface command has been terminated after 9 m (30 ft) of blank tape (ie no data activity found).
** Block	Write current present but no read-after-write data seen, could possibly be Data Control, DDP or ADP board fault.
Deselect	Unit on-line to interface, but not selected by host computer (ie de-selected), and not at BOT.
EOTLIM	The tape has passed 3.6 metres (12 feet) beyond EOT and the 9914 has been commanded to move tape further forwards.
** IDENT	No identifier (compatible with the selected density) found on leaving BOT; possible fault on Data Control, ADP, or DDP board.
Read Only	A write command has been given to a file protected tape (ie WT EN is not illuminated). If writing is required, the operator must unload the tape and fit a 'write enable' ring to the tape reel.
Reject	The last command received was rejected (for reasons other than file protect), the reason is flagged in status byte F9. Reject usually remains displayed until an acceptable command is received; exceptionally (if BOT is found during a 'reverse read') BOT is displayed. Placing the 9914 off-line removes Reject from the display.
** Write	No write current was detected in the heads; possible fault on Power Supply, Data Control, or ADP.

3.3 DIAGNOSTIC PROGRAM ERROR CODES

Details of how to operate the diagnostic programs (and the resulting display messages) are set out in the 9914 User/Diagnostic Manual. Specific details of servicing diagnostics and configuration settings are included in this chapter.

Diagnostic programs can be divided into groups, each designed to assist with a certain area of investigation:

Function(s)	Relevant programs
Parameter set-up	10 - 24, 41 - 44
Tape path sensors	45 - 48
Servo tests	04, 49
Tape motion	50 - 55
Data channels	05 - 09
Configuration/status	67, 68, 70, 81, 93
Initialising	69, 80
Data transfer	25 - 33
Service facilities	72, 73, 74, 78 - 84, 95
Stack manipulation	01, 97, 98, 99.

When a fault is detected by the diagnostics, an error code is displayed which points to a possible faulty FRU. Sometimes fault cause is self-evident, otherwise the FRU(S) most likely to contribute to that fault are listed in this section.

The abbreviations are:

ADP	Analogue Data Paths board, or the heads -
DC	Data Control board
DDP	Digital Data Paths board
Fw	Firmware revision (usually of previously mentioned board)
Op	Operator error
PCI	Pertec Cache Interface board
PS	Power Supply board
SC	Servo Control board
SF	Switch Fascia board
SCSI	SCSI board
Tape	Tape (quality)
TPA	Tape Path Assembly (sensors or tape guidance)

Display	Fault Description	Suspect FRU
F03 Er01	SCSI board not detected, <i>or</i> incompatible with Data Control firmware	SCSI/Fw/DC
F03 Er03	DDP fault	DDP/ADP/DC
F03 Er12	Command error	DC/SCSI
F03 Er14	Timeout waiting for command (from SCSI)	DC/SCSI
F03 Er23	ILWD occurred early	DC/SCSI
F03 Er24	ILWD not recieved	DC/SCSI
F05 Er01	SCSI (or PCI) board not detected, <i>or</i> incompatible with Data Control firmware	SCSI/PCI/Fw/DC
F05 Er03	DDP fault	DDP/ADP/DC
F05 Er04	ADP fault	ADP/DDP
F05 Er12	Command recieved by DC not 'write'	SCSI/PCI/DC/DDP
F05 Er13	Timeout waiting for block	DC/DDP/SCSI/PCI/ADP
F05 Er14	Timeout waiting for command (from SCSI (or PCI))	SCSI/PCI/DC
F05 Er15	ADP fault - no CER status on 1-track kill	ADP/DC
F05 Er16	DDP fault - no CER status on 1-track kill	DDP/DC
F05 Er17	ADP fault - HER status on 1-track kill	ADP/DC
F05 Er18	DDP fault - HER status on 1-track kill	DC/SCSI/PCI/DDP
F05 Er19	ADP fault - no HER status on 3-track kill	ADP/DC
F05 Er20	DDP fault - no HER status on 3-track kill	DC/SCSI/PCI
F05 Er21	NRZ selected	Op
F05 Er22	IFBY reset unexpectedly	DC
F05 Er89	No write ring	Op/SC/DC
F05 Er90	No write current	ADP/DC/PS
F06 Er01	SCSI (or PCI) board not detected, <i>or</i> incompatible with Data Control firmware	SCSI/PCI/Fw/DC
F06 Er02	Head or pre-amplifier fault (or ADP/tape path fault)	
F06 Er03	DDP fault	DDP/DC
F06 Er04	ADP fault	ADP/DC
F06 Er12	Command recieved by DC not 'write'	SCSI/PCI/DC
F06 Er13	Timeout waiting for block	SCSI/PCI/DC
F06 Er14	Timeout waiting for command (from SCSI/PCI)	SCSI/PCI/DC
F06 Er15	ADP fault - no CER status on 1-track kill	ADP/DC
F06 Er16	DDP fault - no CER status on 1-track kill	DDP/DC
F06 Er17	ADP fault - HER status on 1-track kill	ADP/DC
F06 Er18	DDP fault - HER status on 1-track kill	DDP/DC
F06 Er19	ADP fault - no HER status on 3-track kill	ADP/DC
F06 Er20	DDP fault - no HER status on 3-track kill	DDP/DC
F06 Er21	NRZ selected	Op
F06 Er22	IFBY reset unexpectedly	DC
F06 Er89	No write ring	Op/SC/DC
F06 Er90	No write current	ADP/DC/PS

Display	Fault Description	Suspect FRU
F07 Er01	NRZ density selected	Op
F07 Er02	Command recieved by DC not 'write'	DC
F07 Er03	Timeout waiting for block	DC
F07 Er04	6-second timeout elapsed while waiting for new command	DC
F08 Er02	Command recieved by DC not 'write'	DC
F08 Er03	Timeout waiting for block	DC
F08 Er04	6-second timeout elapsed while waiting for new command	DC
F09 Er01	SCSI (or PCI) board not detected, <i>or</i> incompatible with Data Control firmware	SCSI/PCI/Fw/DC
F09 Er12	Command recieved by DC not 'write'	SCSI/PCI/DC
F09 Er13	Timeout waiting for block	SCSI/PCI/DC
F09 Er14	Timeout waiting for command (from SCSI (or PCI))	SCSI/PCI/DC
F09 Er15	ADP fault - no CER status on 1-track kill	ADP
F09 Er16	DDP fault - no CER status on 1-track kill	DDP
F09 Er17	ADP fault - HER status on 1-track kill	ADP
F09 Er18	DDP fault - HER status on 1-track kill	DDP
F09 Er19	ADP fault - no HER status on 3-track kill	ADP
F09 Er20	DDP fault - no HER status on 3-track kill	DDP
F09 Er21	NRZ selected	Op
F09 Er22	IFBY reset unexpectedly	DC
F19 Er01	SCSI board not detected, <i>or</i> incompatible with Data Control firmware	SCSI/Fw/DC
F19 Er02	IFBY line in error	DC/SCSI
F19 Er03	IRD* or IWD* line(s) in error	DC/ADP/SCSI
F19 Er04	Timeout waiting for IDBY false	DC/ADP/SCSI
F19 Er89	No write ring	Op/SC/PS
F21 Er01	SCSI (or PCI) board not detected, <i>or</i> incompatible with Data Control firmware	SCSI/PCI/Fw/DC
F22 Er01	SCSI (or PCI) board not detected, <i>or</i> incompatible with Data Control firmware	SCSI/PCI/Fw/DC
F25 Er01	SCSI (or PCI) board not detected, <i>or</i> incompatible with Data Control firmware	SCSI/PCI/Fw/DC
F25 Er02	HER - status byte has detail	ADP/DDP/DC
F25 Er03	CER - status byte has detail	ADP/DDP/DC
F25 Er89	No write ring	Op/SC/DC
F25 Er90	No write current	ADP/DC/PS
F26 Er01	SCSI (or PCI) board not detected, <i>or</i> incompatible with Data Control firmware	SCSI/PCI/Fw/DC
F26 Er02	HER - status byte has detail <i>TAPE</i>	ADP/tape/DC/DDP
F26 Er03	CER - status byte has detail	tape/ADP/DC/DDP
	Note: 02/03, run 05, if ok Data Control is not the cause	
F26 Er89	No write ring	Op/SC
F26 Er90	No write current	ADP/DC/PS

Display	Fault Description	Suspect FRU
F27 Er01	SCSI (or PCI) board not detected, or incompatible with Data Control firmware	SCSI/PCI/Fw/DC
F28 Er01	SCSI (or PCI) board not detected, or incompatible with Data Control firmware	SCSI/PCI/Fw/DC
F28 Er02	HER - status byte has detail	ADP/tape/DC/DDP
F28 Er03	CER - status byte has detail	ADP/DC/DDP
F29 Er01	SCSI (or PCI) board not detected, or incompatible with Data Control firmware	SCSI/PCI/Fw/DC
F29 Er02	HER - status byte has detail	ADP/DC/DDP
F29 Er03	CER - status byte has detail	tape/ADP/DC/DDP
F31 Er01	Timeout waiting for 'block true'	DC/DDP/ADP
F31 Er02	Timeout waiting for 'block false'	DC/DDP/ADP
F31 Er03	No 'end of file' status	DC/DDP/ADP
F31 Er89	No write ring	Op/SC/DC
F31 Er90	No write current	ADP/DC/PS
F32 Er01	SCSI (or PCI) board not detected, or incompatible with Data Control firmware	SCSI/PCI/Fw/DC
F33 Er01	Error writing ident at lo speed	DDP/ADP/DC
F33 Er02	Error writing ARA level burst at lo speed	DDP/ADP/DC
F33 Er03	Error writing ARA ID burst at lo speed	DDP/ADP/DC
F33 Er10	Density error, status byte F10 defines detail	DDP/ADP/DC
F33 Er11	As Er01, at high speed	
F33 Er12	As Er02, at high speed	
F33 Er13	As Er03, at high speed	
F33 Er20	Density error, status byte F10 defines detail	
F33 Er89	No write ring	Op/SC/DC
F33 Er90	No write current	ADP/DC/PS
F41 Er01	Selected density not available	Op/DDP/DC
F41 Er02	DDP fault	DDP
F42 Er01	Selected density not available	Op/DDP/DC
F42 Er02	DDP fault	DDP
F43 Er01	Selected density not available	Op/DDP/DC
F43 Er02	DDP fault	DDP
F44 Er01	Selected density not available	Op/DDP/DC
F44 Er02	DDP fault	DDP

Display	Fault Description	Suspect FRU
F46 Er01	Ring detected, but no ring fitted	TPA/SC/DC
F46 Er02	Ring not detected, but ring fitted	TPA/SC/DC
F46 Er03	Failure to re-lock the hub	SC
F60 Er89	No write ring	Op/SC/DC
F60 Er90	No head current	ADP/DC/PS
F62 Er89	No write ring	Op/SC/DC
F62 Er90	No head current	ADP/DC/PS
F73 Er01	+12 V	PS/SC
F73 Er02	-12 V	PS/SC
F73 Er03	Reserved	
F73 Er04	-5 V	PS/SC
F73 Er05	+24 V	PS/SC
F74 Er01	ADP monostable calibration error	ADP/DC
F74 Er02	DDP density set-up error	DDP/DC
F74 Er03	Dead track found during ADP write calibration, lo speed	ADP/DDP
F74 Er04	Out-of-range error during ADP write calibration, lo speed	TPA/ADP/DDP
F74 Er05	Dead track found during ADP write calibration, hi speed	TPA/ADP/DDP
F74 Er06	Out-of-range error during ADP write calibration, hi speed	TPA/ADP/DDP
F74 Er11	Dead track found during ADP read calibration, lo speed	TPA/ADP/DDP
F74 Er12	Channel 4 gain signal out of range - ADP read cal, lo speed	ADP/DDP
F74 Er13	Channel 6 gain signal out of range - ADP read cal, lo speed	ADP/DDP
F74 Er14	Channel 0 gain signal out of range - ADP read cal, lo speed	
F74 Er15	Channel 1 gain signal out of range - ADP read cal, lo speed	
F74 Er16	Channel 2 gain signal out of range - ADP read cal, lo speed	
F74 Er17	Channel P gain signal out of range - ADP read cal, lo speed	
F74 Er18	Channel 3 gain signal out of range - ADP read cal, lo speed	
F74 Er19	Channel 7 gain signal out of range - ADP read cal, lo speed	
F74 Er20	Channel 5 gain signal out of range - ADP read cal, lo speed	
F74 Er21	Channel 4 GCV signal out of range - ADP read cal, lo speed	ADP/DDP
F74 Er22	Channel 6 GCV signal out of range - ADP read cal, lo speed	
F74 Er23	Channel 0 GCV signal out of range - ADP read cal, lo speed	
F74 Er24	Channel 1 GCV signal out of range - ADP read cal, lo speed	
F74 Er25	Channel 2 GCV signal out of range - ADP read cal, lo speed	
F74 Er26	Channel P GCV signal out of range - ADP read cal, lo speed	
F74 Er27	Channel 3 GCV signal out of range - ADP read cal, lo speed	
F74 Er28	Channel 7 GCV signal out of range - ADP read cal, lo speed	
F74 Er29	Channel 5 GCV signal out of range - ADP read cal, lo speed	
F74 Er31	Dead track found during ADP read cal - hi speed	

Display	Fault Description	Suspect FRU
F74 Er32	Channel 4 gain signal out of range - ADP read cal, hi speed	ADP/DDP
F74 Er33	Channel 6 gain signal out of range - ADP read cal, hi speed	
F74 Er34	Channel 0 gain signal out of range - ADP read cal, hi speed	
F74 Er35	Channel 1 gain signal out of range - ADP read cal, hi speed	
F74 Er36	Channel 2 gain signal out of range - ADP read cal, hi speed	
F74 Er37	Channel P gain signal out of range - ADP read cal, hi speed	
F74 Er38	Channel 3 gain signal out of range - ADP read cal, hi speed	
F74 Er39	Channel 7 gain signal out of range - ADP read cal, hi speed	
F74 Er40	Channel 5 gain signal out of range - ADP read cal, hi speed	
F74 Er41	Channel 4 GCV signal out of range - ADP read cal, hi speed	
F74 Er42	Channel 6 GCV signal out of range - ADP read cal, hi speed	
F74 Er43	Channel 0 GCV signal out of range - ADP read cal, hi speed	
F74 Er44	Channel 1 GCV signal out of range - ADP read cal, hi speed	
F74 Er45	Channel 2 GCV signal out of range - ADP read cal, hi speed	
F74 Er46	Channel P GCV signal out of range - ADP read cal, hi speed	
F74 Er47	Channel 3 GCV signal out of range - ADP read cal, hi speed	
F74 Er48	Channel 7 GCV signal out of range - ADP read cal, hi speed	
F74 Er49	Channel 5 GCV signal out of range - ADP read cal, hi speed	
F74 Er50	Poor tape (too many high-error areas)	tape
F74 Er51	Skew out of range	TPA
F74 Er52	ADP monostables uncalibrated (calibration otherwise complete)	ADP/DC
F74 Er53	Read calibration out of limits	ADP/TPA/DC
F74 Er54	Read calibration out of range - pre-amp @ maximum gain	ADP/TPA/DC
F74 Er55	Read calibration out of range - pre-amp @ minimum gain	ADP/TPA/DC
F74 Er56	<i>not used</i>	
F74 Er57	Range error when calibrating pre-amp	ADP/TPA/DC
F74 Er89	No write ring	Op/SC/DC
F74 Er90	No write current	ADP/DC/PS
F78 Er89	No write ring	Op/SC/DC
F78 Er90	No write current	ADP/DC/PS
F83 Er89	No write ring	Op/SC/DC
F83 Er90	No head current	ADP/DC/PS
F84 Er89	No write ring	Op/SC/DC
F84 Er90	No write current	ADP/DC/PS

3.4 COMMON ERROR CODES

Error codes 89 and 90 are common to all diagnostic programs, two flowcharts are provided to diagnose the cause of these error codes.

Error Code 89. No write ring was detected, and data could not therefore be transferred to tape. Follow the flowchart of Figure 3.4.1.

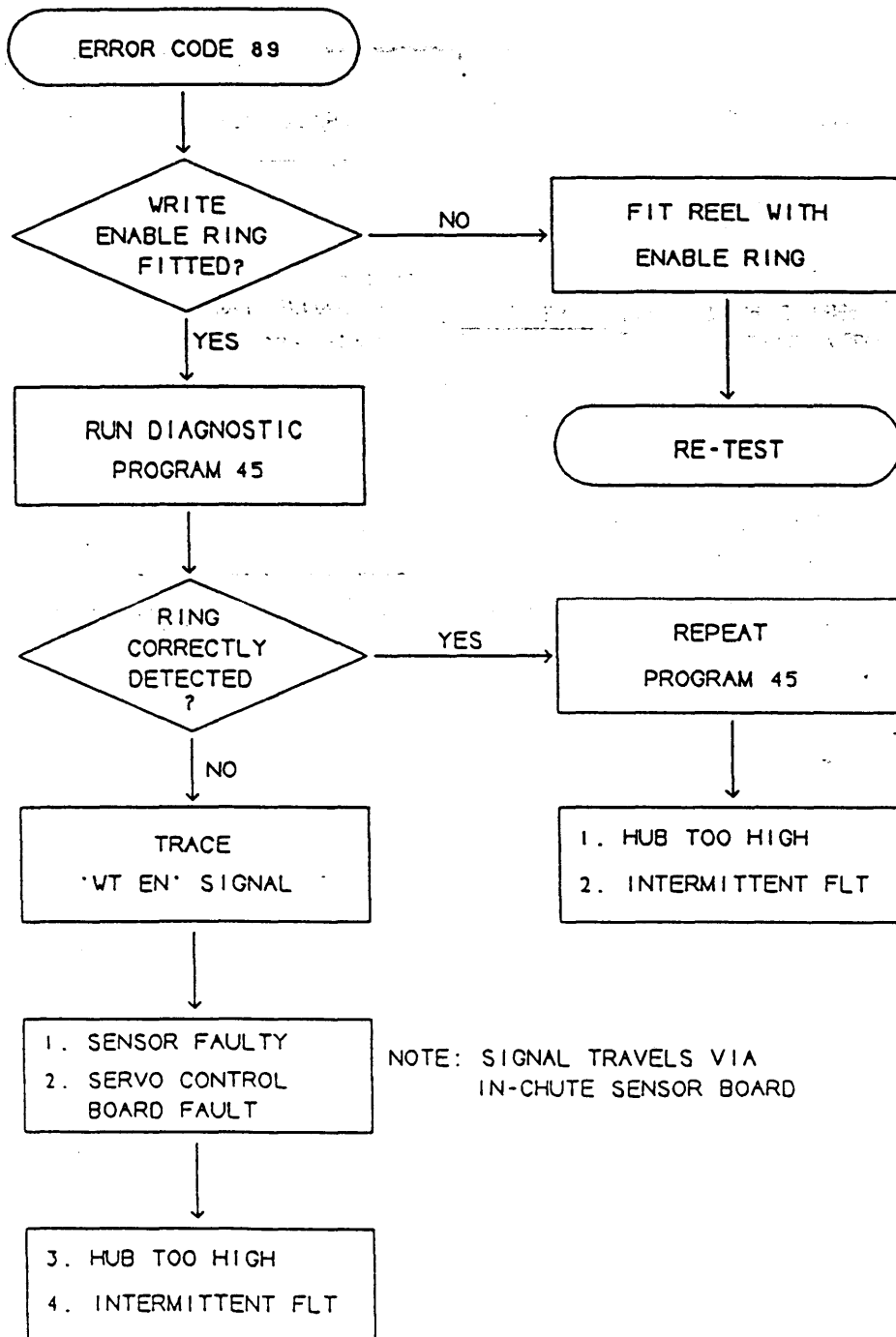

FIGURE 3.4.1 ERROR CODE 89

Error Code 90. While attempting to transfer data to tape, no write current could be sensed.
Follow the flowchart of Figure 3.4.2.

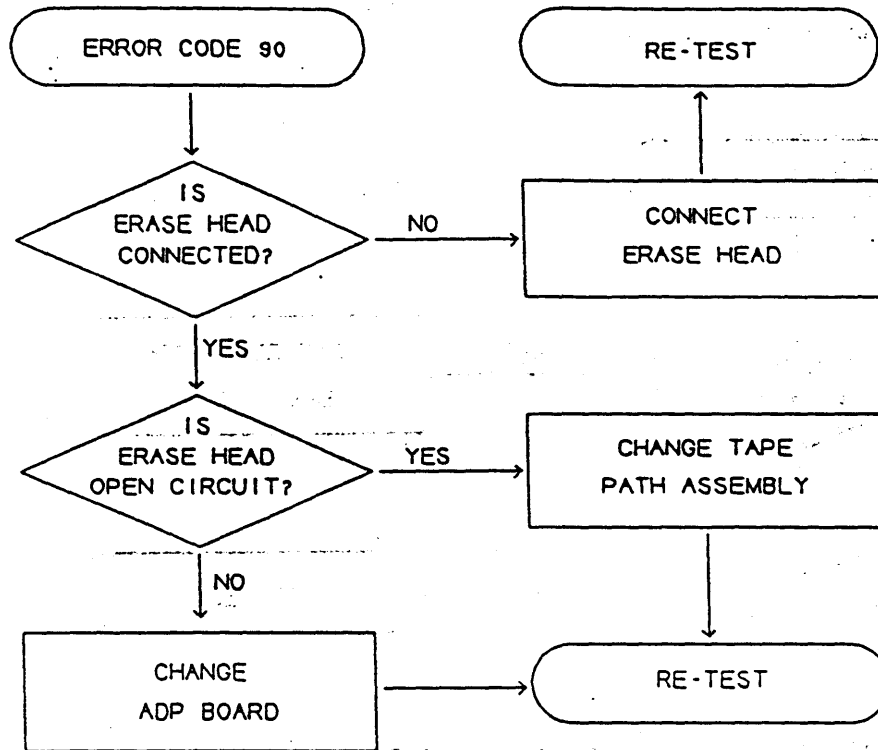

FIGURE 3.4.2 ERROR CODE 90

3.5 DIAGNOSTIC PROGRAM DESCRIPTIONS

NO	FUNCTION	NO	FUNCTION
00	NULL PROGRAM	50	STEP FORWARD (low speed)
01	CONFIDENCE CHECK	51	STEP REVERSE (low speed)
02	RUN STACK FROM HOST	52	ALTERNATE FWD/REV (low speed)
03	ILWD LINE CHECK	53	STEP FORWARD (high speed)
04	AUTO SERVO CHECK	54	STEP REVERSE (high speed)
05	DATA CHANNELS CHECK (non-corruptive)	55	ALTERNATE FWD/REV (high speed)
06	DATA CHANNELS CHECK (corruptive)	56	
07	ADP E-E ✓	57	
08	DDP E-E	58	
09	DATA CHANNEL ERROR REPORTING	59	
10	SET PARAMETERS OF PROG 01	60	ERASE TO EOT
11	SET HIGH SPEED	61	
12	SET LOW SPEED	62	WRITE ALL ONES TO EOT
13	SET N	63	READ FWD TO EOT (low speed)
14	SET BLOCK LENGTH	64	READ FWD TO EOT (high speed)
15	SELECT NON-STREAMING	65	READ REV TO BOT (low speed)
16	SELECT STREAMING	66	READ REV TO BOT (high speed)
17	FAILURE SKIP	67	EXAMINE/MODIFY OPTIONS
18	INCREMENT LOOP COUNTER	68	EXAMINE STATUS BYTES
19	IRD* & IWD* LINE CHECKS	69	INITIALISE STATUS BYTES
20	SET ALL ZEROS DATA	70	EXAMINE PROM REVISIONS
21	SET ALL ONES DATA	71	EXAMINE/MODIFY LANGUAGE
22	SET ALTERNATE I/O DATA	72	OPERATOR DISPLAY CHECK
23	SET PSEUDO RANDOM DATA	73	INTERNAL VOLTAGE CHECK
24	SET FAIL LIMITS	74	DATA CHANNELS AUTO CALIBRATION
25	WRITE, BACKSPACE, READ (N blocks)	75	
26	WRITE N BLOCKS	76	
27	SPACE REVERSE N BLOCKS	77	
28	READ FORWARD N BLOCKS	78	MANUAL WRITE SET-UP
29	READ REVERSE N BLOCKS	79	MANUAL READ SET-UP
30	REWIND	80	SET DEFAULT NVR VALUES
31	WRITE & CHECK FILE MARK	81	EXAMINE/MODIFY NVR VALUES
32	SPACE FORWARD N BLOCKS	82	NRZ READ SKEW MARGINS CHECK
33	WRITE IDENT	83	NRZ WRITE SKEW MARGINS CHECK
34	COMMAND TRACE	84	READ-WRITE CROSS-FEED
35	LOG SENSE DATA	85	
36		86	
37		87	
38		88	
39		89	
40		90	
41	SET 800 bpi	91	
42	SET 1600 bpi	92	
43	SET 3200 bpi	93	EXAMINE LOOP COUNT
44	SET 6250 bpi	94	CLEAR LOOP COUNT
45	SENSORS CHECK	95	ENTER SERVICE KEY
46	FILE PROTECT CHECK	96	
47	TENSION ARM POSITION	97	MODIFY PROGRAM STACK
48	TENSION ARM RESPONSE	98	CLEAR PROGRAM STACK
49	SERVO SETTINGS CHECK ✓	99	RUN PROGRAM STACK

PROGRAM 00	NULL PROGRAM
Description	Useful for entering on the stack with a view to later alterations (eg placed first for later substitution by 'failure skip', program 17) or to 'delete' previous unwanted entries using program 97.
Error Codes	None
PROGRAM 01	MACHINE INTEGRITY TEST
Note	The operator should be aware that the last program in this stack clears the stack. Therefore program 01 should be added to the end of a stack with caution.
Description	A pre-defined sequence of programs (to check the functionality of the 9914) which are placed in the stack. Programs 73, 4 & 30 are run, the following data tests are then run with pre-set parameters: (GCR) 44, 12, 05, 26, 29, 28, 11, 05, 26, 29, 28; (DPE) 43, 11, 05, 26, 29, 28; (PE) 42, 12, 05, 26, 29, 28, 11, 05, 26, 29, 28; (NRZ) 41, 12, 26, 29, 28, 11, 26, 29, 28.
Exit	When program 01 passes, the pre-set parameters remain and the stack is cleared.
Note	If the SCSI (or PCI) board is not fitted, program 01 runs but omits the data-related parts. The SCSI system bus must be properly terminated, either by resistor packs within the 9914 or by maintaining power on the terminating unit.
PROGRAM 02	RUN STACK FROM HOST
Note	Cannot be run from the front panel. If called up by the operator, 'No test' is displayed.
Description	Used by the host to run the 9914 program stack, previously entered across the Pertec interface. The DIAG legend illuminates for the duration of the program stack.
PROGRAM 03	ILWD LINE CHECK
Note	Program 03 is not provided with all firmware revisions, in which case 'No test' is displayed when 'run/stop' is pressed.
Description	Verifies the operation of the ILWD signal (which is part of the unbuffered Pertec interface) by writing a block in E-E mode and applying a timeout during which ILWD must respond.
PROGRAM 04	AUTO SERVO CHECK
Description	Verifies the performance of the servo system, a tape needs to be loaded, but not necessarily at BOT.

PROGRAM 05	DATA CHANNELS CHECK (Non-corruptive)
Notes	The SCSI (or PCI) board must be installed for program 05 to run. Program 05 does not apply to NRZ density.
Description	Incorporate self-contained tests, designed to check the data channel and isolate a faulty sub-assembly (ie the ADP or the DDP) by writing data patterns via E-E paths through the analogue and digital electronics sections. Program 05 does not write data to tape. When there are no errors, tests equivalent to program 09 are automatically carried out.
Note	The status which is flagged by two dead tracks is determined by option byte 07.
PROGRAM 06	DATA CHANNELS CHECK (Corruptive)
Notes	The SCSI (or PCI) board must be installed for program 06 to run. Program 06 do not apply to NRZ density.
Description	Incorporate self-contained tests, designed to check the data channel and isolate a faulty sub-assembly (ie the ADP or the DDP) by writing data patterns via E-E paths through the analogue and digital electronics sections. Program 06 writes data to tape. When there are no errors, tests equivalent to program 09 are automatically carried out.
Note	The status which is flagged by two dead tracks is determined by option byte 07.
PROGRAM 07 PROGRAM 08	ADP E-E CHECK (not applicable to NRZ) DDP E-E CHECK
Description	When run from the front panel, these programs place the relevant board in E-E (electronics-to-electronics) mode and set the 9914 to 'on-line' status (which is not indicated at the front panel), in anticipation of one or more interface 'write' commands. The program ends when 'run/stop' is pressed, with relevant board taken out of E-E mode, and the 9914 set off-line to the interface. When run on-line, the programs expect one interface 'write' command. Programs 07 & 08 are designed for use with the SCSI (or PCI) board removed, because the unbuffered Pertec interface is used.
PROGRAM 09	DATA CHANNEL ERROR REPORTING
Note	The SCSI (or PCI) board must be installed for program 09 to run.
Description	The ADP board is placed in E-E (electronics-to-electronics) mode and each track is killed in turn while a block is written; CER error is expected, but not HER. If the error status is incorrect, the test is repeated with the DDP in E-E mode. Three tracks are then killed while a block is written, HER status is expected. On error, the DDP is placed in E-E mode to isolate the faulty board.
Note	The status which is flagged by two dead tracks is determined by option byte 07.

PROGRAM 10 SET PARAMETERS OF PROGRAM 01

Description Allows the number of blocks, block length, and data pattern used by program 01 to be selected for its use. The defaults are listed under program 01.

The pre-set parameters of program 10 are listed below.

Program	Condition(s)
13	N = 50
14	Block length = 4K
15	Set non-streaming
23	Pseudo random data
24	W Rty = 4, W Err = 4, R Rty = 0, R Err = 0.

The value of N is first presented, to be changed (by the method of program 13) or skipped by pressing DENSITY; the block length is presented second, to be changed (by the method of program 14) or skipped by pressing DENSITY; the data pattern is presented third, to be changed by pressing 'units' until the required pattern is displayed before pressing DENSITY or 'run/stop' to set that pattern.

Notes Once program 10 has been run and the data pattern set, program 01 uses that pattern until power is removed, even if programs 20 - 23 are run.

No purpose is served by running program 10 across the interface, since all its features are available separately.

PROGRAM 11 SET HIGH SPEED

Note 125 ips tape speed is not available at 3200 bpi density.

Description Sets the higher tape speed, prior to starting other programs. When run 'Hi speed' is displayed for 1 second.

PROGRAM 12 SET LOW SPEED

Description Sets the lower tape speed, prior to starting other programs. When run 'Lo speed' is displayed for 1 second.

PROGRAM 13	SET N
Note	Should not be entered onto the stack because operator intervention is required.
Description	Allows the operator or host to set N to a new value, which may be in the range of 1 to 255 ₁₀ .
Operator:	Allows the operator to update N, which is indicated on the display, by the use of DIAG, 'tens', or 'units' buttons. The 'run/stop' button is pressed when the desired value is displayed. N is set from the time of update, not just when the stack is subsequently run.
Host:	The host effectively updates N when certain SCSI commands are sent, as described in the SCSI User Manual. The new value of N is active while the SCSI command is running, but N reverts to its previous value afterwards.
PROGRAM 14	SET BLOCK LENGTH
Description	Sets the length of subsequent data blocks for programs which write data to tape. Blocks may normally be from 1 byte up to 32 Kbytes long, in increments of powers of two. Some programs restrict the block length. When run from the front panel, the display indicates (say) LEN = 16K, to increase the block size, use the 'tens' button, to decrease the size, use the 'units' button.
PROGRAM 15	SELECT NON-STREAMING
Description	Sets the 9914 write and read programs so that the tape is repositioned after each block is traversed.
PROGRAM 16	SELECT STREAMING
Description	Sets the 9914 write and read programs so that the tape is kept in motion after each block is traversed (ie streaming mode).
PROGRAM 17	FAILURE SKIP
Note	Is only effective when entered in a program stack.
Description	Causes subsequent failing programs to be aborted, thus allowing a stack to skip to the next program without stopping on errors. Status bytes F4 (and C4) are incremented up to FF ₁₆ (255 ₁₀) when an error occurs.
PROGRAM 18	INCREMENT LOOP COUNTER
Description	When entered in a program stack, program 18 increments a counter, typically to record the number of times the stack loops (assuming program 99 is at the end of the stack). The user may subsequently use programs 93/94 to examine/clear the loop counter. The counter increments up to 9,999 ₁₀ , then holds without overflowing.

PROGRAM 19 **IRD* & IWD* LINE CHECKS**

Note Program 19 is not provided with all firmware revisions, in which case 'No test' is displayed when 'run/stop' is pressed.

Description Verifies the operation of the read and write data lines (which are part of the unbuffered Pertec interface) by executing a write-rewind-read sequence and comparing the data.

- PROGRAM 20** **SET ALL ZEROS DATA**
- PROGRAM 21** **SET ALL ONES DATA**
- PROGRAM 22** **SET ALTERNATE I/O DATA**
- PROGRAM 23** **SET PSEUDO RANDOM DATA**

Note The SCSI (or PCI) board must be installed for programs 20 - 23 to run.

Description Set the preset data bytes, prior to running other programs, to the stated pattern.

PROGRAM 24 **SET FAIL LIMITS**

Description Sets the number of errors which are encountered before programs 25, 26, 28, or 29 are deemed to have failed, when run from the front panel. When writing, any error causes a 'backspace & erase' so that each re-try takes place over a fresh piece of tape until the re-try limit is reached or writing is successful.

When run, the limits may be changed by means of the 'tens' and 'units' buttons:

W Rty = number of write re-tries per block, before the test fails

W Err = number of block failures before the test fails

R Rty = number of read re-tries per block, before the test fails

R Err = number of read failures before the test fails.

The various re-try results are treated as follows.

If no error occurs on any read/write attempt, the test proceeds to the next block.

If an error occurs, and the number of re-tries has not reached the W Rty/R Rty

limit, a re-try is executed on the current block but a re-try register is incremented.

The test fails if the re-try register count reaches W Err/W Err, or if the W Rty/R Rty count is reached in any one block.

PROGRAM 25 **WRITE, BACKSPACE, READ**

Description Writes N blocks of data with:

- speed as selected by program 11 or 12;
- N as set by program 13;
- block length as set by program 14;
- streaming/non-streaming as set by program 15 or 16;
- data pattern as set by programs 20 - 23;
- density as selected by programs 41 - 44.

The program then reverse-spaces, and reads the blocks.

Note Pressing 'Density' while an error is displayed will cause the current density and speed to appear on the display.

PROGRAM 26 WRITE N BLOCKS

Description Writes N blocks of data with:

- speed as selected by program 11 or 12;
- N as set by program 13;
- block length as set by program 14;
- streaming/non streaming as set by program 15 or 16;
- data pattern as set by programs 20 - 23;
- density as selected by programs 41 - 44.

Note Pressing ' Density ' while an error is displayed will cause the current density and speed to appear on the display.

PROGRAM 27 SPACE REVERSE N BLOCKS

Description Spaces reverse over N blocks with:

- speed as selected by program 11 or 12;
- N as selected by program 13;
- streaming/non streaming as set by program 15 or 16;
- data content being ignored.

PROGRAM 28 READ FWD N BLOCKS

Description Reads forward N data blocks while looking for status errors, with:

- speed as selected by program 11 or 12;
- N as set by program 13;
- streaming/non streaming as set by program 15 or 16;
- density as selected by programs 41 - 44.

Note Pressing ' Density ' while an error is displayed will cause the current density and speed to appear on the display.

PROGRAM 29 READ REVERSE N BLOCKS

Description Reads N data blocks in reverse while looking for status errors with:

- speed as selected by program 11 or 12;
- N as set by program 13;
- density as selected by programs 41 - 44.

PROGRAM 30 REWIND

Description Tape is rewound to BOT, may be used for positioning the tape prior to running other programs.

Error Codes None

PROGRAM 31 WRITE & CHECK FILEMARK

Description Writes a file mark to tape in the current density format, checking the 'file mark' pattern is read as the tape passes.

	bit	7	6	5	4	3	2	1	0
byte	(hex)								
byte 0	00	SCSI Command							
byte 1	01	Completion Status							
byte 2	02	0	0	0	0	0	Initiator ID		
byte 3	03	0	0	0	0	0	Target ID		
byte 4	04	SCSI Sense Byte 0							
byte 5	05	SCSI Sense Byte 1							
byte 6	06	SCSI Sense Byte 2							
byte 7	07	SCSI Sense Byte 3							
byte 8	08	SCSI Sense Byte 4							
byte 9	09	SCSI Sense Byte 5							
byte 10	0A	SCSI Sense Byte 6							
byte 11	0B	SCSI Sense Byte 12							
byte 12	0C	SCSI Sense Byte 13							
byte 13	0D	9914 Status Validity (00 = valid)							
byte 14	0E	9914 Status Byte F5							
byte 15	0F	9914 Status Byte F6							
byte 16	10	9914 Status Byte F7							
byte 17	11	9914 Status Byte F8							
byte 18	12	9914 Status Byte F9							
byte 19	13	9914 Status Byte F10							
byte 20	14	9914 Status Byte F11							
byte 21	15	9914 Status Byte F12							
byte 22	16	9914 Status Byte F14							

Table 3.5.1 STATUS TRACE FORMAT

PROGRAM 41 SET 800 bpi
 PROGRAM 42 SET 1600 bpi
 PROGRAM 43 SET 3200 bpi
 PROGRAM 44 SET 6250 bpi

Description Changes the data encoding circuits to handle the stated density. When non-diagnostic mode is restored, the density remains at this new setting.

PROGRAM 45 SENSORS CHECK

Note Tape should not be loaded.
 If it is at BOT, the program will unload, otherwise rewind the tape first.

Description Indicates the state of the tape path sensors which are used during tape loading and tape motion, each display letter should be interpreted as in the table opposite. The sensor outputs are picked up by the Servo Control board at connector P5 and routed to IC34 (use IC34.7 as an earth point).

Additionally the operator may check the operation of the hub lock solenoid, loading door solenoid and fan drive circuits:

- press 'tens' hub solenoid is activated;
- press 'units' door solenoid is activated;
- press 'enter' loading fan is activated.

The door and hub solenoids operate from +48 V for one second, switching to +24 V thereafter. The loading fan operates from +24 V.

Letter	C	R	B	E	W	L
Sensor	in-chute	reel located	BOT	EOT	write enable	tension limit
Meaning of letter	chute clear	flag detected	marker present	marker present	flag detected	not in limit
P5 pin	4	32	20	18	34	28
IC34 pin	9	1	13	11	5	3
On (V)	<1.0	<1.0	0.35	0.35	<1.0	<1.0
Off (V)	pulsed	>2.0	3.2-4.7	3.2-4.7	>2.0	>2.0

When running the program, check the indications as follows:

- C place an opaque object in the chute, 'C' should disappear while the chute is blocked, when examining the transmitter output the 'high' pulses are seen to switch between 4 and 5 volts.
- R rotate the supply hub slowly for a complete revolution, 'R' should remain displayed; place a reel of tape on the hub and rotate again, 'R' should disappear three times per revolution.
- B place a reflective tape marker tab about 3 mm away from the BOT/EOT block, 'B' should appear only when the reflection is picked up. If marker detection problems have occurred and this test fails, check the operation of the detector circuits as described in Section 4 under 'Tape Path Assembly'.
- E similar to B.
- W remove the 'write enable' ring from a reel of tape, place the reel on the supply hub and rotate slowly for a complete revolution, 'W' should not appear at all. Fit a 'write enable' ring to the tape reel, replace it on the hub and rotate slowly for a complete revolution, 'W' should appear once per revolution.
- L should not be displayed with the tension arm at rest; moving the arm away from its rest position should cause 'L' to appear until the far travel limit is reached, when 'L' should disappear.

The WT EN legend is lit when the flag is detected.

PROGRAM 46 FILE PROTECT TEST

Note Tape should not be loaded.
If it is at BOT, the program will unload, otherwise rewind the tape first.

Description After unloading any tape and opening the loading door, the operator is requested to remove the write enable ring, insert the tape reel, and then press the 'tens' button. The program then checks that no ring has been detected.

The operator is next requested to fit the write ring and then press 'tens'. The program then checks that the ring has been detected.

PROGRAM 47 TENSION ARM POSITION

Note Tape should not be tensioned for this test.

Description The display first indicates 'LIMIT XXX', where XXX is a three-digit number related to the output from the tension arm position sensor.

As the arm is moved away from its rest end, the LIMIT part of the message should disappear (denoting that the arm is no longer at its travel limit) and the XXX number should increase from about 80 to about 180 as the far end limit is encountered, when LIMIT should re-appear.

This sequence verifies that the tension arm output and limit flags are visible to the Servo Control processor; the quoted XXX values should not be regarded as defining acceptable performance but as an indication of symmetry of the tension arm sensor. Acceptable performance is an output variation from +1.0 (± 0.2) V to -1.0 (± 0.2) V at IC1.7 on the tension arm board.

PROGRAM 48**TENSION ARM RESPONSE**

Note Program 48 is only used when problems have been encountered with the tension arm going into limit (ie tension being lost). When this happens, the tape tension should be checked (see Section 3.9) and only if it is *within* limits should program 48 be run.

Description

Displays the fly time of the tension arm, between the limit flags, under the influence of the tension arm spring.

Unload the tape, move the arm against the spring, through its full travel towards the head, release the arm and allow it to fly to the rest position unimpeded.

The display indicates the fly-time of the arm (in milli-seconds), a value between 20 and 30 is acceptable, but only values below 20 or above 40 are likely to affect the 9914's performance.

PROGRAM 49**SERVO SETTINGS CHECK****Warnings**

Only a trained service engineer should run this program, after removing any tape from the machine.

Description

Input stimuli are applied to the Servo Control motor drive circuits, in order to allow an engineer to probe around the circuits and investigate whether the response is correct or otherwise. The various display responses are:

EXIT

Denotes the first exit point of the program after pressing 'run/stop', the normal operator action is to press 'DIAG' here.

LEVEL .1

Level 1 test mode has been selected (where the operator calls full or zero demand on either servo circuit). Press 'run/stop'.

RUN 49.1

Level 1 test mode is now active.
 Press 'tens' to place full demand on the TU servo circuit;
 press 'units' to place full demand on the SU servo circuit;
 press 'enter' to place zero demand on both servo circuits
 (but with both output stages energised);
 press 'run/stop' to switch off the output stage.
 Press 'DIAG' when level 1 mode is no longer required.

LEVEL .2

Level 2 test mode has been selected (where the operator calls for the current demand to ramp on either servo circuit). Press 'run/stop'.

RUN 49.2

Level 2 test mode is now active.
 Press 'tens' to slowly ramp up the current demand to the TU servo, after which the demand slowly ramps down through zero to full demand in the opposite direction. Pressing 'tens' a second time holds the current level, pressing 'tens' a third time resumes the ramp.
 Press 'enter' to place zero demand on both servo circuits (output stages energised).
 Press 'units' to place ramp current demand on the SU servo, in a similar manner to that described for the TU servo.
 Press 'run/stop' to switch off the output stage and exit from level 2.
 Press 'DIAG' to move on to level 3.

LEVEL .3 Level 3 test mode has been selected (where the operator calls for the speed demand to ramp on either servo circuit). Press 'run/stop'.

RUN 49.3 Level 3 test mode is now active.
Press 'tens' to slowly ramp up the speed demand to the TU servo, after which the demand slowly ramps down through zero to full demand in the opposite direction. Pressing 'tens' a second time holds the speed demand, pressing 'tens' a third time resumes the ramp.
Press 'enter' to place zero speed demand on both servo circuits, but leave the speed servo action running and the output stages energised.
Press 'units' to place ramp speed demand on the SU servo, in a similar manner to that described for the TU servo.
Press 'run/stop' to switch off the output stage and exit from level 3.
Press 'DIAG' to display the exit mode.

EXIT Denotes the last exit point of the program, press 'run/stop' here.

TEST 49 Denotes the end of diagnostic program 49.

PROGRAM 50 STEP FORWARD (low speed)

Description The tape is stepped forward at low speed to EOT.
The size of the steps may be altered by holding the 'tens' or 'units' button.

PROGRAM 51 STEP REVERSE (low speed)

Description The tape is stepped in reverse at low speed to BOT.
The size of the steps may be altered by holding the 'tens' or 'units' button.

PROGRAM 52 ALTERNATE FORWARD/REVERSE (low speed)

Description The tape is run alternately forward/reverse, at the low speed
The size of the steps may be altered by holding the 'tens' or 'units' button.

PROGRAM 53 STEP FORWARD (high speed)

Description The tape is stepped forward at high speed to EOT.
The size of the steps may be altered by holding the 'tens' or 'units' button.

PROGRAM 54 STEP REVERSE (high speed)

Description The tape is stepped reverse at high speed to BOT.
The size of the steps may be altered by holding the 'tens' or 'units' button.

PROGRAM 55 **ALTERNATE FORWARD/REVERSE (high speed)**

Description The tape is alternated at high speed
The size of the steps may be altered by holding the 'tens' or 'units' button.

PROGRAM 60 **ERASE TO EOT & REWIND**

Description The tape is erased to EOT at the speed selected by program 11 or 12. The tape is rewound when EOT is reached.

PROGRAM 62 **WRITE ALL ONES TO EOT & REWIND**

Description 'All ones' data is written to EOT, with;
- speed as selected by program 11 or 12;
- density as selected by programs 41 - 44.
The tape is rewound when EOT is detected.

PROGRAM 63 **READ FORWARD TO EOT (low speed)**
PROGRAM 64 **READ FORWARD TO EOT (high speed)**

Description The tape is run forward to EOT, with the read circuits enabled.

PROGRAM 65 **READ REVERSE TO BOT (low speed)**
PROGRAM 66 **READ REVERSE TO BOT (high speed)**

Description The tape is run reverse at low speed to BOT, with the read circuits enabled.

PROGRAM 67 **EXAMINE/MODIFY OPTIONS**

Description Displays all the option bytes, indicating as follows at the various steps:

OPT 01 Indicated upon first entering diagnostic program 67, the desired option number (which is flashing) can now be changed by depressing the 'units' button.

OPT 05 When the desired option is displayed, press DIAG.

UNIT 01 Indicated after the desired option has been selected, and DIAG has been pressed. This example is the current setting of option 05.

If option 05 is to be altered, use the 'tens' and 'units' buttons to display its new setting, otherwise proceed to the next step.

UNIT 02 When the required option setting is displayed, press DIAG to revert to displaying option numbers.

OPT XX If no further options are to be changed, press 'run/stop' to exit diagnostic program 67, otherwise repeat the procedure for other option(s).

The displays associated with the options 01 to 05 are:

Option 01 (Duration of density display)

DNSDIS-1 Density displayed until 'run/stop' or 'tens' pressed
DNSDIS-0 Density displayed for 5 seconds only.
Note: press 'units' to flip the display between these settings.

Option 02 (Door opening after an unload)

AUTO DOR Door opens automatically after unload.
MAN DOOR 'Reset' must be pressed to open the after unloading.
Note: press 'units' to flip the display between these settings.

Option 03 (Auto on-line)

AUTO ONL 9914 automatically goes on-line after loading has completed.
MAN ONL 9914 is on-line only after 'LD/ONL' is pressed.
Note: press 'units' to flip the display between these settings.

Option 04 (Auto load)

AUTOLOAD 9914 automatically loads tape to BOT on closing the door.
MAN LOAD 9914 loads tape when 'LD/ONL' button is pressed.
Note: press 'units' to flip the display between these settings.

Option 05 (Unit address)

UNIT XX Where XX is the current unit address (valid in the range 0 to 7).

Options 06 to 18 are described and tabulated in Section 3.12.

Warning

Changing options 06 to 18 may affect the response of the 9914 to the host, and/or the format of recorded data; they should only be altered in the full knowledge of the result.

Options 06 to 18 are displayed in hexadecimal notation, pressing the 'tens'/'units' buttons changes the most/least significant four bits respectively; pressing DIAG updates the displayed option. Pressing 'run/stop' causes an exit from program 67.

option 06 - host interface options A;
option 07 - host interface options B;
option 08 - host interface options C;
option 09 - host interface options D;
option 10 - conditions which set 'incomplete';
option 11 - conditions which set 'reject';
option 12 - write gap size;
option 13 - miscellaneous A;
option 14 - SCSI (or PCI) options A,
option 15 - SCSI (or PCI) options B;
option 16 - density configurations;
option 17 - SCSI (or PCI) options C;
option 18 - miscellaneous B;

PROGRAM 68 **EXAMINE STATUS BYTES**

Description Displays all the full status bytes (F1 to F17) by a method similar to program 67, the display indicates as follows at the various steps:

- SNS F01* Indicated upon first entering diagnostic program 68, during this 'byte selection' phase, the desired status byte number can now be changed by using the 'tens' and 'units' buttons.
- SNS F05* When the desired byte is displayed, press DIAG.
- 11000100* Typical indication after the desired byte has been selected, and DIAG has been pressed. This is the current setting of status byte F05 (left digit is most significant). Press DIAG again to return to the 'byte selection' phase.
- SNS F05* If no further bytes are to be examined, press 'run/stop' to exit diagnostic program 68, otherwise repeat the procedure for the next status byte.

Error Codes None

PROGRAM 69 **INITIALISE STATUS BYTES**

Description Clears most of the status bytes to zero, or (where otherwise applicable) presets them to the correct value.
All error logs are thereby cleared, ensuring that future status byte contents do not reflect past operations.

PROGRAM 70 **EXAMINE PROM REVISIONS**

Description Earlier 9914's (with Data Control boards before assembly state 15) display the installed servo and data PROM revisions, in the form of a scrolled message. The SCSI firmware issue can be obtained via the 'inquiry' command.

Later 9914's display the installed Servo Control, Data Control, DDP, and SCSI PROM revisions, in the form of a scrolled message.
If DENSITY is held depressed when the message has begun to scroll, the creation date and time are displayed.

PROGRAM 71 **EXAMINE/MODIFY LANGUAGE**

Note The language may have been previously set via the interface, which may subsequently over-ride any setting made with program 71.

Description The current language appears on the display. The language of the display messages may be changed by pressing:

- 'tens' next available language;
- 'units' previous language.

When the chosen language has been selected, press 'run/stop' to exit program 71 with that language.

PROGRAM 72 OPERATOR DISPLAY CHECK

Description Causes all the legends and display segments on the control panel to illuminate in turn; the alpha-numeric display cycles through its character set.

PROGRAM 73 INTERNAL VOLTAGE CHECK

Description Measures the internal regulated voltage lines to ensure that they are present. This assumes the presence of +5V and avoids having to probe inside the machine.

The voltages used by the main assemblies are listed in the table, switching on without a particular assembly may remove a short which was affecting that rail.

	Servo Control	Data Control	DDP	ADP	SCSI	Tape Path (& pre-amp)	Tacho
+12	y	-	-	y	-	y	-
-12	(y)	-	-	y	-	y	-
-5	y	-	-	-	-	-	-
+24	y	-	-	-	-	-	-

PROGRAM 74 DATA CHANNELS AUTO CALIBRATION

Warning Program 74 should only be run in response to a specific fault diagnosis, and after any hardware fault has been cleared, recalibration for its own sake merely overwrites a good set of parameters.

Note The service key (program 95) is required for program 74. A standard output tape is recommended for calibration. This is a tape where the recording characteristics are traceable back to NBS references; while most tapes do not depart significantly from these, the use of an unknown tape may cause parameters to be set which cause known tapes to give marginal performance.

The head and tape path must be clean before calibration is attempted. The head outputs are affected by oxide deposits and debris on tape path components may contaminate a good tape.

The small-signal circuits (eg the ADP read channels) require a warmup time of about 15 minutes before their parameters settle. If program 74 is run with the intention of setting the full range of precise parameters, the 9914 should have been previously powered up with its set of boards for 15 minutes.

Description Automatically re-calibrates the data channels at all densities, re-setting the:

- (i) read channel monostables;
- (ii) write currents;
- (iii) pre-amplifier gain;
- (iv) read gains;
- (v) read-after-write NRZ skew delays.

While read calibration is active, the density and pass number is indicated; a pass constitutes two sets of measurements, if the results are diverse, the pass is repeated. The 'poor tape' error code denotes that 5 passes produced diverse results.

Variations

The byte at address 812A in the NVR may be reset during program 81 to omit parts of the calibration procedure.

Prior to Data Control firmware 4C, location 812A was set to the value 40, the bit allocations were:

b7	b6	b5	b4	b3	b2	b1	b0
-	preamp	-	-	ADP monos	NRZ skew	write channels	read gains

From Data Control firmware 4C, location 812A has been set to the value 08, the bit allocations are:

b7	b6	b5	b4	b3	b2	b1	b0
GCR	DPE	PE	NRZ	preamp	write channels	read gains	- -

Note In both instances a 1 causes that part to be inhibited.
Address 812A should be reset to its original value (40 or 08) before the 9914 is returned to online use (the stated values are not power-on defaults).

PROGRAM 78 **MANUAL WRITE SET-UP**

Note The service key (program 95) is required for program 78.

Description Allows the service engineer to vary the data channel parameters while writing data to tape continuously; an oscilloscope is required.

PROGRAM 79 **MANUAL READ SET-UP**

Note The service key (program 95) is required for program 79.

Description Allows the service engineer to vary the data channel parameters while reading data from a continuously written tape; an oscilloscope is required.
The AGC is switched on/off at 1 kHz.

PROGRAM 80 **SET DEFAULT NVR VALUES**

Note The service key (program 95) is required for program 80.

Description Allows the service engineer to replace all the current bytes in the non-volatile RAM area by go/no-go values which are held in EPROM. This should only be done after a catastrophic failure, because the 9914 is thereby completely re-initialised with go/no-go NVR values (including the read/write parameters and the configuration options). The user should therefore be well aware that all current values in the NVR are destroyed by program 80, and that suitable values must afterwards be re-created by running program 74 before re-entering the configuration options (including the SCSI settings).
When program 80 is initiated, the service key code (program 95) must be entered a second time before NVR value replacement proceeds.

PROGRAM 81	EXAMINE/MODIFY NVR VALUES
Note	The service key (program 95) is required for program 81.
Description	Allows the service engineer to display and alter any of the bytes in the non-volatile RAM area. The bytes are displayed in hexadecimal notation.
PROGRAM 82	NRZ READ SKEW MARGINS CHECK
Notes	The service key (program 95) is required for program 82. A pre-recorded skew tape is required.
Description	The skew tape is run forward while reading data with a reduced 'character assembly time'. Any non 'all ones' data detected causes the display count to increment. The NVR skew delays are not changed. When EOT is detected, the tape is returned to BOT and the test passes.
Caution	If the program is stopped before EOT is reached, the skew tape should be returned to BOT at low speed (as recommended by the tape manufacturer) using diagnostic program 65.
PROGRAM 83	NRZ WRITE SKEW MARGINS CHECK
Note	The service key (program 95) is required for program 83.
Description	After switching to NRZ density, the tape is run forward writing 'all ones' data using a reduced 'character assembly time'. Any non 'all ones' data detected causes the display count to increment. The NVR skew delays are not changed. The test passes when EOT is detected. If NRZ is not selected, 'Dens Err' appears on the display.
PROGRAM 84	WRITE-READ CROSS-FEED
Note	The service key (program 95) is required for program 84.
Description	Writes an 'all ones' data without moving the tape, to enable the service engineer to measure the cross-feed between the write and read heads.
PROGRAM 93	EXAMINE LOOP COUNT
Description	Displays the loop count (described under program 18) in decimal.
PROGRAM 94	CLEAR LOOP COUNTER
Description	Clears the loop counter (described under program 18).

PROGRAM 95 **ENTER SERVICE KEY**

- Caution** This should only be used with the full knowledge of which parameters are to be changed and the reasons for change. Using the key to enable a random 'trial and error' method is likely to change the basic operating parameters; full operational status may then require program 80 and a recalibration procedure.
- Description** The basic function is to allow the user to enter the service key combination, which (if correct) causes PASS to be displayed. Programs which require the service key may then be run, until the power is next turned off.
- The Key** Press 'DIAG' twice;
press 'tens' twice;
press 'units' twice;
the display should read PASS 95.
- Interlock** The safety interlock is overridden by entering the service key, thereby allowing operation with the tape path cover open. When the turnbuckle nearest the front panel is next secured, interlock override reverts to inhibiting tape motion while the tape path cover is open.
- Revisions** The diagnostic code revision and compatibility number may be examined (without the service key) by depressing 'run/stop', DIAG, and then 'enter', strictly in that order. The code revisions are displayed as a message of the type:
C/R 0302 SCSI 0301,
the two leading numbers (in each group of four) are compatibility numbers (in this example 03), and must be identical; while the second two numbers are revisions at that compatibility level.

PROGRAM 97 **MODIFY OPERATOR STACK**

- Note** Program 97 should not be entered onto the stack.
- Description** Allows the operator to step through the existing operator stack by pressing the 'enter' button. Substituting a program number (using the 'tens'/'units' buttons) may be carried out prior to pressing the 'enter' button. A program in the stack may be effectively deleted by changing it to program 00.

PROGRAM 98 **CLEAR OPERATOR STACK**

- Description** Program 98 clears the current program stack.

PROGRAM 99 **RUN OPERATOR STACK**

- Description** When called, the current program stack is run sequentially, starting at the first program entered.
- If program 99 is entered onto the program stack it causes the stack to loop back to the first entry and repeat.
- Error Codes** See details of individual programs entered onto the stack.

3.6 ADDITIONAL FAULT-FINDING IDEAS

This section deals with less commonly found faults by suggesting possible causes, investigations and/or remedies. Where appropriate the reader is referred to the relevant chapter or alternative publication for more detailed information.

The streamer should be checked for obvious faults such as mechanical damage or missing sub-assemblies before fault finding is commenced.

Note that there is an automatic fault diagnostic routine which is invoked whenever power is connected to the streamer (see Section 3.2).

Notes:

If a board is changed, reference should be made to Chapter 4 to determine whether any re-calibration or option settings must be performed.

Before changing the tape path assembly, check that the problem is not caused by a head cable fault.

3.6.1 Fault Types

Streamer faults may be generalised as follows:

3.6.1.1 Off-line Faults

- . Power-on failures.
- . The streamer does not load, hold, or move tape correctly.
- . Failure during diagnostic programs.

3.6.1.2 On-line Faults

- . An installation or configuration fault.
- . A host interface or host program fault.
- . A streamer fault, not mentioned in Section 3.6.1.1.
- . Operator misuse.

Some on-line faults can be diagnosed by use of the streamer diagnostic routines, which can be called from the host across the unbuffered Pertec, Pertec cache, or SCSI interfaces. The techniques are outlined here, but detailed use of the diagnostics depends on the host system configuration.

3.6.2 Off-line Faults

Faults are listed in order from switching on the 9914, through auto-load, to the analyse function and setting 'on-line'. Remedies which suggest checking power supply rails also imply checking the fuse if the output is dead.

POSSIBLE CAUSES	INVESTIGATION/REMEDY	REFERENCE
1a ... Cooling fan inactive		
No mains power.	Check switch/fuse/source	Chapter 4
Fuse blown.	Replace with correct value & type	Chapter 4
+24V rail faulty.	Check +24 V arrives at fan	Chapter 4
1b ... Loading fan always on		
Servo Control board fault.	Diagnostic program 45	Section 3.5
Fan lead fault.	Check continuity Substitute fan	
2 ... 8-character display blank (just after power-on, cooling fan active)		
Power Supply fault.	Measure output voltages	Chapter 4
Connector fault.	Check placement	Figure 3.3.1
Servo Control fault.	Check 'proc ok' led	On = processor ok
Switch Facia board fault.	Substitute board	Chapter 4
Faulty display chip.	Substitute board	Chapter 4
3 ... 8-character display extinguishes (previously functional)		
+5 V rail failed.	Check @ Power Supply board	Chapter 4
Mains supply failed.	Check fuse/restore power	Chapter 4
4 ... Display indicates 'POWER'		
Power Supply fault (excl +5V).	Run diagnostic program 73 Check at @ Power Supply board	Section 3.5 Section 2.7
5 ... Display active but not indicating 'LOCATING' or 'OK' after power-on diagnostics		
General fault	Check/substitute FRU	Section 3.2.1
Switch Facia board fault.	Check/substitute board	Chapters 2 & 4
Servo Control board fault.	Check/substitute board	Chapters 2 & 4

POSSIBLE CAUSES	INVESTIGATION/REMEDY	REFERENCE
6a ... Door always locked (Latch Engaged)		
Latch obstructed.	Diagnostic program 45	Section 3.5
Solenoid not operating.	Continuity check	Chapter 4
Servo Control board fault.	Diagnostic program 45	Section 3.5
	Substitute board	Chapter 4
6b ... Door fails to lock		
Latch obstructed.	Diagnostic program 45	Section 3.5
Solenoid always energised.	Diagnostic program 45	Section 3.5
Servo Control board fault.	Diagnostic program 45	Section 3.5
	Substitute board	Chapter 4
7a ... LD/ONL button not effective (ie no LOCATING indicated)		
Button/board fault.	Check @ Servo Control board	Chapter 2
7b ... Door Closure not effective (ie no LOCATING indicated)		
Switch/board fault.	Check @ Servo Control board	Chapter 2
8 ... Other buttons not effective		
As (7)	Check @ Servo Control	Chapter 2
9 ... 'LOCATING' indicated but no reel motion		
SU motor disconnected.	Diagnostic program 49	Section 3.5
Servo Control board fault.		
10 ... Reel clamp inoperative		
Clamp arm stuck.	Diagnostic program 45	Section 3.5
Solenoid inoperative.	Diagnostic program 45	Section 3.5
'Reel located' fault.	Diagnostic program 45	Section 3.5
Servo Control board fault.	Substitute board	Chapter 2
Hub motor fault.	Diagnostic program 49	Section 3.5
11 ... Tape not feeding from supply reel		
End attraction to bulk.	Longitudinal pinch at end	
Loading fan fault.	Manual load	Chapter 3
Servo Control board fault.	Check driving ability	Diagnostic program 04
Excessive air leak.	Check tape path cover, or load manually	Chapter 4 (loading fan) Chapter 3

POSSIBLE CAUSES	INVESTIGATION/REMEDY	REFERENCE
12 ... Take-up spool static (during load)		
TU motor fault. Servo Control board fault.	Check continuity/brushes Check driving ability	Chapter 4 Diagnostic program 49
13 ... Tension arm off-centre (tape tensioned)		
Tension spring obstructed. Position sensor fault.	Remove/reposition obstruction Check output at mid-position	Chapter 4
14 ... Supply reel clamped askew		
Flange fouled. Distorted reel.	Reload Discard and substitute	
15 ... DIAG not illuminating		
LED faulty/disconnected. DIAG button faulty. Servo Control board fault.	Diagnostic program 72 Servo Control board Control panel checkout	Chapter 2 Chapter 4
16 ... Data tests give frequent errors		
Tape quality. Dirty tape path. Inter block transitions. Modulation.	Substitute known good tape Routine cleaning schedule Should be < 4% of nominal Check tape speed Check tape path	User/Diagnostic Manual ECMA/ANSI Chapter 3 Chapter 4
Channel imbalance.	Part of re-calibration Examine head profile	Diagnostic program 74
Low read amplitude.	Part of re-calibration Examine head profile	Diagnostic program 74
ADP (or other) board fault.	Substitute & re-calibrate	Diagnostic program 74
Tape path fault.	Identify faulty component	Chapter 4
17 ... Unstable tension arm (more than 10 mm travel during tape motion)		
Tension arm damping poor. Servo gain incorrect. Tape tension low.	Diagnostic program 48 Diagnostic program 04 Check tension	Section 3.5 Chapter 3 Chapter 3
18 ... BOT not found		
Leader too short. Marker not detected. No BOT marker.	Manual load Check detection circuit Attach marker	Chapter 3 Chapter 4 ANSI/ECMA

POSSIBLE CAUSES	INVESTIGATION/REMEDY	REFERENCE
-----------------	----------------------	-----------

19 ... Density cannot be changed

Tape not at BOT Configuration option	Reverse to BOT Operator change forbidden	Option byte 16
---	---	----------------

20 ... Door fails to open after unload

Door solenoid fault Servo Control board fault	Diagnostic program 45 Substitute board	Section 3.5 Chapter 4
--	---	--------------------------

3.6.3 On-line Faults

POSSIBLE CAUSES	INVESTIGATION/REMEDY	REFERENCE
-----------------	----------------------	-----------

1 ... ONLINE status does not Latch (ie legend goes out)

Tape not loaded. DIAG illuminated. RESET active. LD/ONL button fault. 'Off-line' host command. Tape path cover opened IFEN not asserted.	Cancel Check @ Servo Control Check @ Servo Control Close and secure all turnbuckles Option byte 08	Section 3.14
--	--	--------------

2 ... ONLINE status indicated, but subsequently drops out

Tape path cover opened Door switch fault Tape tension loss Run off EOT end of tape Board fault Interface fault	Press LD/ONL Check its operating point Diagnostic program 52 or 55 Check options/host software Substitute Servo Control board Substitute Data Control board Try again/examine host software
---	---

3 ... 9914 not responding to any commands

Not on-line. Incorrect configuration. Incorrect connections. Incorrect address. Unsuitable interface	Press LD/ONL Examine option bytes Check Pertec SK1/SK2 are not interchanged or inverted Check option byte 08 or 15 Product Specification	Section 3.14 M G0595-A
--	---	---------------------------

POSSIBLE CAUSES	INVESTIGATION/REMEDY	REFERENCE
4 ... Density selection ineffective		
Density not available. 3200 bpi not available	Config byte 18 Config byte 16, bit 4	Section 3.12 Section 3.12
5 ... Speed selection ineffective		
Operator panel enabled. (inhibits interface).	Config byte 13, bit 3	Section 3.12
6 ... Streamer not responding to specific commands		
Invalid command.	INV CMD displayed Non-standard command Product Specification	User/Diagnostic Manual Option byte 16 M G0595-A
Unsuitable interface.		
7 ... Hard error on every block		
3200 bpi tape, without ident burst.	Analyse selected 800 bpi	Set density to 800 bpi, review option byte 09, bit 0
8 ... Data transfer not reliable		
See off-line faults, Item 16 Unreliable interface.	Unsuitable/misplaced interface connector Product Specification	M G0595-A
Unsuitable interfacing.		
9 ... Tape does not move forward		
Head > 3.6 m beyond EOT <i>Note: block may be only partially written</i>	Rewind or reverse motion	
10 ... Unable to read a particular tape		
Tape is unreadable	Try on another machine Try a known readable tape Substitute DDP board	Chapter 4
Circuit fault		

POSSIBLE CAUSES**INVESTIGATION/REMEDY****REFERENCE**

11 ... Does not go off-line after pressing RESET

Tape in motion	Wait until it stops
Data still in buffer	Wait until buffer is cleared
Host is powered off	Wait about 10 seconds

12 ... 6250 bpi active after 3200 bpi selected

Alternative 6250 bpi code	Byte 16, bit 4 = 1	Section 3.12
---------------------------	--------------------	--------------

3.7 MANUAL TAPE LOADING

Since the 9914 is designed for fully automatic loading it is not normally necessary (or desirable) to manually lace the tape except under fault conditions such as a failed loading fan.

Set power off, open the tape path cover, place the tape reel centrally on the supply hub, and lace the tape through to the take-up hub. Wind on about two anti-clockwise turns (an access hole is provided to facilitate take-up) until the tape is pulled through when the tape-up reel is rotated by hand.

When the tape has been laced, close the tape path cover, set power on, and close the tape loading door. Wait until the display indicates TESTING, then LOCKING, then LOADING. The loading firmware will sense that tape is already laced and proceed to clamp the supply reel, tension the tape, and search for BOT without the operator taking any further action.

3.7.1 Switching off with Tape Laced

Always ensure that the tape is returned to BOT, or unloaded before switching off. The servos are designed with a dynamic braking effect to prevent tape loops forming following power failures or accidental switching off.

3.7.2 Switching on with Tape Already Laced

If power is removed with the tape under tension, press LD/ONL if LOCKING is not indicated within a few seconds of power being restored. The control firmware will sense that tape is already laced and move it to BOT without operator intervention.

This feature is effective whether before or after BOT.

If the tape path cover is unintentionally released with the tape already laced, secure it again and press LD/ONL if auto-load does not commence within a few seconds.

3.8 AZIMUTH CHECKING/SETTING

The azimuth setting is fixed at the factory, when the head mounting block, which is a cantilever arrangement, is fitted to the head plate. The adjusting screw (which is visible in the tape path, near the tacho) has a differential thread to enable fine adjustment of azimuth.

The modified M8 cap screw (visible from under the head plate) must on no account be turned, since this has been set to determine the initial location of the adjusting screw.

3.9 TAPE TENSION CHECKING/SETTING

Tape tension resulting from the tension arm spring is pre-determined and not adjustable; perform the following tension check if this parameter is suspect.

- (i) Set power off, examine the tension spring area for obstruction or fouling and remedy if necessary.
- (ii) Raise the tape path cover.
- (iii) Use the spring balance to apply force at the roller axis and perpendicular to length of the arm. With the arm in its mid-travel position, alternately pull and release the arm by a few mm. The average force indicated should be 270 gf \pm 30 gf.

If the tension is out of limits, check that the spring anchor pillar is not bent; when there is no pillar distortion, examine the spring assembly for wear or damage, otherwise replace the spring.

As alternative method, a length of tape with a loop at either end may be attached to the final roller and threaded back through the tape path to the supply reel chamber. A spring balance may then be attached to the SU end of the loop and tension applied until the tension arm is at mid-position (with the tape touching the first roller). Two readings should be taken, with the arm centered from both directions, the average reading is the tape tension.

3.10 TAPE SPEED CHECKING

3.10.1 Average Tape Speed

- (i) Set power off
- (ii) Hinge the chassis up, and monitor IC20.13 (or R151 - heatsink end) on the Servo Control board with a frequency counter (or an oscilloscope if a counter is not available).
- (iii) Set power on, select the required speed and density (diagnostic programs 11/12, 41/42/43/44) and record the tacho frequency while running programs 63/64/65/66.
Note: any speed error is likely to be the result of a digital circuit malfunction, giving a gross error which is easily detected by an oscilloscope.
- (v) The tacho pulse frequency should be within 2% of the nominal value:

Density (bpi)	NRZ 800		PE 1600		DPE 3200	GCR 6250	
Speed (ips)	41.66	125	41.66	125	62.5	41.66	125
Frequency (kHz)	10.42	31.25	10.42	31.25	15.63	10.42	31.25

TABLE 3.10 9914 TACHO FREQUENCIES

3.10.2 Tape Speed Variations

No adjustment is provided for tape speed because it is determined by the servo processor deriving servo demand from the tacho pulses. If the tacho pulses are jittering or not of the correct frequency the following may contribute:

- tacho surface slippery, clean as described in the 9914 User/Diagnostic Manual;
- poor tape path, resulting in heavy edge contact and speed jitter;
- erratic reel motors, caused by worn brushes;
- tape fouling against the take-up hub flange, reset the TU hub height (see Chapter 4).

3.11 RE-CALIBRATION

Re-calibration of the 9914 should only be necessary following:

- replacement of the Tape Path assembly (including the pre-amp);
- replacement of the ADP board;
- replacement of the Data Control board.

Diagnostic program 74 re-calibrates the 9914 data channels at all densities, without the need for special tools or test leads.

Note: artwork issue 1 ADP boards will give error 52, this is normal, these boards require the monostables to be reset. ADP boards later than issue 1 should pass program 74 without errors and require no re-setting.

The procedures for setting up the ADP monostables is set out in Appendix B.

3.12 CONFIGURABLE OPTIONS

Most options are held in non-volatile RAM, which can be examined or altered by running diagnostic program 67.

The various option bytes are listed next, with the significance of each bit. Option bytes 00 to 05 are described under diagnostic program 67.

3.12.1 Option Byte 06 - Host Interface Options A

Bit	Interpretation
7	1 = EOT latched until passed again in reverse 0 = EOT pulsed every time the marker is detected (except in rewind)
6	1 = IOFL sets streamer off-line, no other action 0 = IOFL sets streamer off-line, rewinds to BOT, unloads tape
5	1 = All forward commands rejected after EOT limit is set 0 = No command restrictions after EOT limit is set (<i>user must ensure that physical end-of-tape is not reached</i>)
4	1 = Incoming write data checked for odd parity, IHER set if error (<i>and bit 0 in status byte F7</i>); used with bit 3 below 0 = Incoming write data parity ignored, odd parity generated
3	1 = DPE/PE or NRZ write data parity is written to tape, even if wrong; enables even parity tapes, but R-A-W data causes IHER to set (<i>GCR ignores incoming parity, for writing to tape</i>) 0 = DPE/PE or NRZ write data parity is corrected before writing to tape
2	1 = Automatic density analysis (at conclusion of loading) is inhibited (<i>default density - byte 16 - is assumed</i>) (<i>GCR read auto-calibration is not operative</i>) 0 = Automatic density analysis is enabled
1	1 = Pertec INRZ interface line is set when GCR density is selected (<i>valid after IDBY set during first command from BOT</i>) 0 = INRZ has NRZ density meaning only
0	Applies only if density is changed after analyse: 1 = read @ analyse density, write from BOT @ new density 0 = read @ analyse density, write from BOT @ new density, if no previous read

3.12.2 Option Byte 07 - Host Interface Options B

Bit Interpretation

- 7-4 1 = Gap before a file mark is normal IBG
- 0 = Gap before a file mark is 3.5 inches

- Bit 7 = GCR gap
- Bit 6 = PE 1600 gap
- Bit 5 = DPE 3200 gap
- Bit 4 = NRZ gap

Note: when streaming, the gap *after* a file mark may be longer than normal, when byte 12 is set for 'variable gap'.

- 3 1 = IRSTR strobes generated with NRZ LRC & CRC characters
- 0 = IRSTR strobes not generated with NRZ LRC & CRC characters

- 2 1 = ICER true (in GCR write) for double-track error correction
- 0 = ICER true (in GCR) for single or double-track correction
- Default = 0; note: this option affects ICER in GCR density only*

- 1 1 = Read strobes continue after multi-track errors in PE densities
- 0 = Read strobes cease after multi-track errors in PE densities

- 0 -

3.12.3 Option Byte 08 - Host Interface options C

Bit Interpretation

- 7 -

- 6 1 = IFBY clears immediately after IDBY clears
- (facilitates streaming by hosts which re-instruct from IFBY)*
- 0 = IFBY clears after the re-instruct time has expired

- 5 1 = IFBY set true on the leading edge of the command strobe IGO
- 0 = IFBY set true on the trailing edge of the command strobe IGO
- Note: the PCI board has its own edge selecting option*

- 4 1 = 9914 responds to the host irrespective of IFEN state, but IFEN going high terminates the current command
- 0 = IFEN must be asserted before on-line status is possible, even if correctly addressed by host, or placed on-line at the front panel
- IFEN must be asserted for commands to be accepted
- Note: pulsing IFEN clears IHER & ICER, either option setting*

- 3 -

2-0 Unit address settings:

b2	b1	b0	
0	0	0	Unit address 0
0	0	1	Unit address 1
			.. and so on ...
1	1	1	Unit address 7

3.12.4 Option Byte 09 - Host Interface options D

<i>Bit</i>	<i>Interpretation</i>
7	1 = Disable 3200 bpi IDENT when reading (no interface IIDENT even if one is present) 0 = Enable 3200 bpi IDENT reporting across interface
6	1 = Disable 3200 bpi IDENT when writing 0 = Enable 3200 bpi IDENT when writing
5	1 = IHER & ICER pulsed at end of block (no need to justify errors with IDBY) 0 = IHER & ICER set until cleared
4	1 = Ignore read IDENT error from BOT and read first block 0 = tape halted if IDENT error from BOT during read, *** IDENT displayed, IHER set, bit 7 of status byte F10 set <i>Note: when writing from BOT, IDENT error is flagged as for '0' setting</i>
3	1 = An illegal command sequences IDBY & IFBY as normal 0 = An illegal command sets and clears IFBY, IDBY unaffected, (host informed of reject command without reference to status bytes) (Rejected commands set bit 7 of status byte F7, regardless of this option)
2	1 = 3200 bpi read commands enabled, write commands rejected 0 = 3200 bpi read commands & write commands enabled
1	1 = Density mismatch sets IHER, and bit 2 of F14 0 = Density mismatch sets bit 2 of F14, but does not set IHER
0	1 = Analyse density default is 3200 bpi when no ident burst is found 0 = Analyse density default is 800 bpi when no ident burst is found

3.12.5 Option Byte 10 - Conditions which set Incomplete

Note: 'incomplete' is bit 6 of status byte F7.

The interpretation of all bits is:

<i>Bit</i>	<i>Interpretation</i>
All	1 = the status byte INCOMPLETE bit is set and IHER is asserted 0 = the status byte INCOMPLETE bit is not set (IHER is not asserted), (but another status byte bit may be set)
7	No read-after-write data detected during writing (RWFFAIL)
6	BOT detected during 'read reverse' (RRD @ BOT)
5	BOT detected during 'file search reverse' (FSR BOT)
4	Blank tape found during 'read' (BLANK TAPE)
3	IFEN asserted during an operation (IFEN)
2	-
1	-
0	No erase current detected during a write operation (/WTNG)

3.12.6 Option Byte 11 - Conditions which set Reject

Note: 'reject' is bit 7 of status byte F7.

The interpretation of all bits is:

<i>Bit</i>	<i>Interpretation</i>
All	1 = the status byte REJECT bit is set and IHER is asserted 0 = the status byte REJECT bit is not set (IHER is not asserted), (but another status byte bit may be set)
7	-
6	-
5	-
4	Forward motion requested when tape is at EOT limit (EOTLIM CMD) (applies only if bit 5 of option 06 is set)
3	Command code was not recognised - eg invalid combination (INV CMD)
2	Reverse command received while at BOT (REV @ BOT)
1	Write command received, to a file-protected tape (FPTD)
0	Set density command received while away from BOT (DENS /BOT)

3.12.7 Option Byte 12 - IBG Size

When the 9914 is streaming, byte 12 determines the gap which *follows* a block of data (or a file mark). When set to a variable code, the gap ceases when a new command is received, should this not happen before the maximum gap, a reposition cycle is entered and the resulting inter-block gap is of normal length (assuming the new command is 'write').

If the 9914 repositions on every block, the resulting tape thus contains IBG's of normal length, regardless of the setting of byte 12.

Bit Interpretation

7-4 Most significant nibble, GCR gap size

3-0 Least significant nibble, PE/NRZ gap size

MSN Hex code	Normal GCR	LSN Hex Code	Normal PE/NRZ
0 -	0.3	- 0	0.5
1 -	0.4	- 1	0.6
2 -	0.6	- 2	1.0
3 -	1.0	- 3	1.5
4 -	1.5	- 4	2.0

MSN Hex code	Variable GCR min - max	LSN Hex code	Variable PE/NRZ min - max
5 -	0.3 - 0.6	- 5	0.5 - 1.0
6 -	0.3 - 1.0	- 6	0.5 - 1.5
7 -	0.3 - 1.5	- 7	0.5 - 2.0
8 -	0.3 - 2.0	- 8	0.6 - 1.0
9 -	0.4 - 1.0	- 9	0.6 - 1.5
A -	0.4 - 1.5	- A	0.6 - 2.0
B -	0.4 - 2.0	- B	0.6 - 2.5
C -	0.4 - 2.5	- C	0.6 - 3.0
D -	0.4 - 3.0	- D	0.6 - 3.5
E -	0.4 - 4.0	- E	0.6 - 4.0
F -	0.4 - 6.0	- F	0.6 - 6.0

3.12.8 Option Byte 13 - Miscellaneous Options

Bit Interpretation

- 7 1 = All rewinds performed at the slower (archive) speed
0 = All rewinds performed at the maximum speed
(3,600 feet in less than 100 seconds)
- 6 1 = SCSI (or PCI) is fitted
0 = No buffered interface is fitted (*data diagnostics do not run*)
- 5 Reserved for customer option
(*each specific customer is aware of this function*)
- 4 1 = SCSI (or PCI) options determined by NVR contents (ie bytes 14, 15 & 17 below)
0 = SCSI (or PCI) options determined by board switches
- 3 1 = Speed selection enabled via the operator panel (see below)
0 = Speed selection enabled via the host interface
- 2 1 = Speed sets to high on power-up
0 = Speed sets to low on power-up
- 1 Reserved for customer option
- 0 Reserved for customer option

Operator Speed Selection

When the 9914 is on-line, press DIAG momentarily while the tape is stationery to display the current speed setting. If a speed change is required, hold the DIAG button depressed until the indication changes, then release it immediately.

If bit 3 is 0, the DIAG button is ignored.

If the tape is in motion, the DIAG button is ignored.

If the 9914 is off-line, the DIAG button invokes diagnostic mode.

3.12.9 Option Byte 14 - SCSI Options A

Note: the equivalent PCI options are set out in Section 3.12.14 onwards

The 9914 (in combination with SCSI boards p/n 12197X and 1235XX) provides two methods of setting the SCSI options:

- (a) by means of the switches on the SCSI board;
- (b) by means of the configuration option bytes 13-15 (& 17).

When bit 4 of byte 13 is set, the SCSI options are determined by the other configuration bytes (held in NVR) and the actual hardware settings of the board switches are ignored. An NVR bit at '1' is equivalent to a board switch 'off'.

If the board switch settings are changed in the field, the NVR contents are not automatically changed to reflect the new settings.

If any SCSI option bit is changed (using diagnostic program 67), bit 4 of byte 13 is automatically set. Subsequent SCSI options are therefore determined by the NVR contents - which may differ from the board switch settings.

The option switch identities vary with the artwork issue, as tabulated at the end of Section 3.12.12.

(a) SCSI with PROM 123107, up to revision 11

<i>Bit</i>	<i>Interpretation</i>
------------	-----------------------

7	1 = Parity check enabled (SW2-1) 0 = Parity check inhibited
6	1 = Disconnect enabled (SW2-2) 0 = Disconnect inhibited
5	1 = Attention reporting enabled (SW2-3) 0 = Attention reporting inhibited
4	1 = Recovered error reporting enabled (SW2-4) 0 = Recovered error reporting inhibited
3	1 = High speed burst mode (SW2-5) 0 = Slow continuous mode
2	1 = Remote density selection enabled (SWC6-6) 0 = Remote density selection inhibited
1	1 = Engineering tool (SWC6-7) 0 = Normal operational setting
0	1 = Issue B onwards of pcb p/n 12197X, or any issue of p/n 1235XX 0 = Issue A of pcb p/n 12197X series boards (SWC6-8)

(b) SCSI with PROM 123107, revisions 11 & 12

Bit Interpretation

- 7 1 = Parity check enabled (SW2-1)
0 = Parity check inhibited
- 6 1 = Disconnect enabled (SW2-2)
0 = Disconnect inhibited
- 5 1 = Attention reporting enabled (SW2-3)
0 = Attention reporting inhibited
- 4 1 = Recovered error reporting enabled (SW2-4)
0 = Recovered error reporting inhibited
- 3 1 = High speed burst mode (SW2-5)
0 = Slow continuous mode
- 2 1 = Remote density, speed and buffered selection enabled (SW2-6)
0 = Remote density, speed and buffered selection inhibited
- 1 1 = Engineering tool (SW2-7)
0 = Normal operational setting
- 0 1 = Issue B onwards of pcb p/n 12197X, or any issue of p/n 1235XX
0 = Issue A of pcb p/n 12197X series boards (SWC6-8)

(c) SCSI with PROM 123107 revision 14, & PROM 123996 revision 01

Bit Interpretation

- 7 1 = Parity check enabled (SW2-1)
0 = Parity check inhibited
- 6 1 = Disconnect enabled (SW2-2)
0 = Disconnect inhibited
- 5 1 = Attention reporting enabled (SW2-3)
0 = Attention reporting inhibited
- 4 1 = Recovered error reporting enabled (SW2-4)
0 = Recovered error reporting inhibited
- 3 1 = High speed burst mode (SW2-5)
0 = Slow continuous mode
- 2 1 = Remote density, speed and buffered selection enabled (SW2-6)
0 = Remote density, speed and buffered selection inhibited
- 1 Code compatibility (with bit 0 and byte 15, bit 4) (SW2-7)
- 0 Code compatibility (with bit 1 and byte 15, bit 4) (SW2-8)

(d) SCSI with PROM 123996, revisions 02 & 03

<i>Bit</i>	<i>Interpretation</i>
7	1 = Parity check enabled (SW2-1) 0 = Parity check inhibited
6	1 = Disconnect enabled (SW2-2) 0 = Disconnect inhibited
5	1 = Attention reporting enabled (SW2-3) 0 = Attention reporting inhibited
4	1 = Recovered error reporting enabled (SW2-4) 0 = Recovered error reporting inhibited
3	1 = High speed burst mode (SW2-5) 0 = Slow continuous mode
2	Code compatibility (with bits 1, 0 and byte 15, bit 4)
1	Code compatibility (with bit 0 and byte 15, bit 4)
0	Code compatibility (with bit 1 and byte 15, bit 4)

3.12.10 Option Byte 15 - SCSI Options B

(a) SCSI with PROM 123107, up to revision 11

<i>Bit</i>	<i>Interpretation</i>
7	1 = Remote speed selection enabled (SW3-1) 0 = Remote speed selection inhibited
6	<i>Unused, up to revision 9</i> <i>Revision 9 and onwards:</i> 1 = Tape halted and 'check condition' upon read into EOT (SW3-2) 0 = EOT ignored when reading
5	<i>Unused</i>
4	<i>Unused</i>
3	1 = Look-ahead read enabled (SW1-4) 0 = Look-ahead read disabled
2-0	SCSI ID address setting: (SW1-3, 2, & 1)
	b2 b1 b0
	1 1 1 SCSI address 7
	1 1 0 SCSI address 6
	... and so on ...
	0 0 0 SCSI address 0

(b) SCSI with PROM 123107, revisions 11 & 12

Bit Interpretation

- 7 1 = File mark status reported read, space, or write (SW3-1)
0 = File mark status reported read or space only
- 6 1 = Tape halted and 'check condition' upon read into EOT (SW3-2)
0 = EOT ignored when reading
- 5 1 = Irrecoverable write errors finish with head on BOT side of attempt (SW3-3)
0 = Irrecoverable write errors finish with head on EOT side of attempt
- 4 *Unused*
- 3 1 = Look-ahead read enabled (SW1-4)
0 = Look-ahead read disabled
- 2-0 SCSI ID address setting: (SW1-3, 2, & 1)

b2	b1	b0	
1	1	1	SCSI address 7
1	1	0	SCSI address 6
			... and so on ...
0	0	0	SCSI address 0

(c) SCSI with PROM 123107 revision 14 & PROM 123996 revision 01

Bit Interpretation

- 7 1 = File mark status reported read, space, or write (SW3-1)
0 = File mark status reported read or space only
- 6 1 = Tape halted and 'check condition' upon read into EOT (SW3-2)
0 = EOT ignored when reading
- 5 1 = Irrecoverable write errors finish with head on BOT side of attempt (SW3-3)
0 = Irrecoverable write errors finish with head on EOT side of attempt
- 4 Code compatibility (with bits 1 & 0 of byte 14)
- 3 1 = Look-ahead read enabled (SW1-4)
0 = Look-ahead read disabled
- 2-0 SCSI ID address setting: (SW1-3, 2, & 1)

b2	b1	b0	
1	1	1	SCSI address 7
1	1	0	SCSI address 6
			... and so on ...
0	0	0	SCSI address 0

(d) SCSI with PROM 123996, revisions 02 & 03

Bit Interpretation

- 7 1 = File mark status reported read, space, or write (SW3-1)
0 = File mark status reported read or space only
- 6 1 = Tape halted and 'check condition' upon read into EOT (SW3-2)
0 = EOT ignored when reading
- 5 1 = Irrecoverable write errors finish with head on BOT side of attempt (SW3-3)
0 = Irrecoverable write errors finish with head on EOT side of attempt
- 4 Code compatibility (with bits 2, 1, 0 of byte 14), see below
- 3 1 = Buffered write EOM flagged following buffer dump in EW area
0 = Buffered write EOM flagged when physical EOT detected
- 2-0 SCSI ID address setting: (SW1-3, 2, & 1)

b2	b1	b0	
1	1	1	SCSI address 7
1	1	0	SCSI address 6
			... and so on ...
0	0	0	SCSI address 0

Code Compatibility

The difference between 'standard' and 'special' codes is the response to the 'Inquiry command'.

The 'standard' code is normally set, unless the customer requires the alternative response.

3.12.11 Option Byte 16 - Density

Bit Interpretation

7-5 Power-up default density:

b7	b6	b5	
0	0	x	800 bpi NRZ
0	1	x	1600 bpi PE
1	0	x	3200 bpi DPE
1	1	x	6250 bpi GCR

4-2 Host interface selection:

b4	b3	b2	
x	0	x	Standard encoded commands
x	1	x	Option A encoded commands (see below)
x	x	0	IHIDEN on PL1/36, IHISP on PL2/50
x	x	1	IHIDEN/IHISP pins exchanged
1	x	x	Alternative '6250 bpi select' code: b4 = 0, 6250 = 1 1 0 0 0 (the standard code) b4 = 1, 6250 = 1 0 1 1 1 (3200 bpi is not available)

1 & 0 Density change enable:

b1	b0	
1	0	Via the interface only
0	1	Via the front panel only
1	1	Via the interface or front panel

Option A Encoded Commands

Bit 3 provides for alternatives to the usual command set, the only difference so far implemented is a different '800 bpi select' code.

IREV	IWRITE	IWFM	IEDIT	IERASE	
1	1	0	0	1	Standard '800 bpi select'
1	1	1	0	0	Option A '800 bpi select'

3.12.12 Option Byte 17 - SCSI Options C

Note: option byte 17 has no hardware equivalent.

Bit Interpretation

7 - 4 -

3-0 Look-ahead read termination

b3	b2	b1	b0	
0	0	0	0	255 file marks (ie no effective termination)
0	0	0	1	Look-ahead read terminates on every file mark
0	0	1	0	Look-ahead read terminates on 2 consecutive file marks
0	0	1	1	Look-ahead read terminates on 3 consecutive file marks .. and so on ...
1	1	1	1	Look-ahead read terminates on 15 consecutive file marks

The option switch identities vary with the particular artwork issue, as tabulated next.

Board P/N	12197X Series		1235XX Series
	A	B - D	A & B
Artwork Issue			
SCSI ID	0G-1	SWG0-1	SW1-1
"	0G-2	SWG0-2	SW1-2
"	0G-3	SWG0-3	SW1-3
High performance	0G-4	SWG0-4	SW1-4
Parity checking	6C-1	SWC6-1	SW2-1
Disconnect	6C-2	SWC6-2	SW2-2
Attention	6C-3	SWC6-3	SW2-3
Recovered error	6C-4	SWC6-4	SW2-4
Data trans mode	6C-5	SWC6-5	SW2-5
See text	6C-6	SWC6-6	SW2-6
See text	6C-7	SWC6-7	SW2-7
See text	6C-8	SWC6-8	SW2-8
See text	6D-1	SWD6-1	SW3-1
See text	6D-2	SWD6-2	SW3-2
See text	6D-3	SWD6-3	SW3-3
See text	6D-4	SWD6-4	SW3-4

3.12.13 Option Byte 18 - Miscellaneous B

<i>Bit</i>	<i>Interpretation</i>
------------	-----------------------

7 & 6	<i>Unused</i>
-------	---------------

5	1 = High speed disabled when on-line 0 = High speed allowed when on-line
---	---

4	1 = Low speed disabled when on-line 0 = Low speed allowed when on-line
---	---

3	1 = 6250 bpi density disabled when on-line 0 = 6250 bpi density allowed when on-line
---	---

2	1 = 3200 bpi density disabled when on-line 0 = 3200 bpi density allowed when on-line
---	---

1	1 = 1600 bpi density disabled when on-line 0 = 1600 bpi density allowed when on-line
---	---

0	1 = 800 bpi density disabled when on-line 0 = 800 bpi density allowed when on-line
---	---

3.12.14 Option Byte 14 - PCI Options A

The 9914 (in combination with PCI boards p/n 123702 and 123704) provides two methods of setting the PCI options:

- by means of the switches on the PCI board, *or*
- by means of the configuration option bytes 13-15 (& 17).

When bit 4 of byte 13 is set, the PCI options are determined by the other configuration bytes (held in NVR) and the actual hardware settings of the board switches are ignored. An NVR bit at '1' is equivalent to a board switch 'on'.

If the board switch settings are changed in the field, the NVR contents are not automatically changed to reflect the new settings.

If any PCI option bit is changed (using diagnostic program 67), bit 4 of byte 13 is automatically set. Subsequent PCI options are therefore determined by the NVR contents - which may differ from the board switch settings.

Bit Interpretation

- | | |
|---|--|
| 7 | 1 = Lower range of interface data rates (SW1-8)
0 = Higher range of interface data rates
(byte 15, bits 2-0 select the actual rates) |
| 6 | 1 = IFBY sets on leading edge of IGO (SW1-7)
0 = IFBY sets on trailing edge of IGO |
| 5 | 1 = Disables the parity check of incoming host data (SW1-6)
0 = Enables the parity check of incoming host data |

For cache mode 2:

- | | |
|---|---|
| 4 | 1 = IEOT status is set when the reflective marker is detected (SW1-5)
0 = IEOT status is set as soon as the tape enters the early warning area |
|---|---|

For cache modes 1 and 4 (and read in cache mode 2):

- | | |
|---|--|
| 4 | 1 = IEOT status is set when the reflective marker is detected (SW1-5)
0 = IEOT status is set at the end of the first data block,
written after the reflective marker is detected |
|---|--|

For all cache modes:

3 & 2 Retry count

b3 (SW1-4)	b2 (SW1-3)	
0	0	0 write / 4 read
0	1	16 write / 4 read
1	0	32 write / 8 read
1	1	48 write / 12 read

1 & 0 Cache mode control:

b1 (SW1-2)	b0 (SW1-1)	
0	0	Mode 2 (normal cache)
0	1	Mode 1 (non-cache)
1	0	Mode 3 (<i>reserved</i>)
1	1	Mode 4 (non-cache, long block)

3.12.15 Option Byte 15 - PCI Options B

Bit Interpretation

7 *Unused*

6 & 5 Code Compatibility:

b6 (SW2-7)	b5 (SW2-6)	
0	0	<i>M4 Data standard emulation</i>
0	1	<i>STK 2920 emulation</i>
1	0	<i>QT14 emulation</i>
1	1	<i>M4 Data 9905 emulation</i>

4 & 3 Electronic Ramp Delay:

b4 (SW2-5)	b3 (SW2-4)	
0	0	0 ms
0	1	2 ms
1	0	4 ms
1	1	8 ms (read), 120 ms (write)

2-0 Host Interface Data Rates (kB/s):

Note: the range is selected by byte 14, bit7.

b2 (SW2-3)	b1 (SW2-2)	b0 (SW2-1)	(B14, b7 = 1)	(B14, b7 = 0)
0	0	0	10	278
0	0	1	30	312
0	1	0	50	357
0	1	1	72	416
1	0	0	100	500
1	0	1	120	625
1	1	0	156	833
1	1	1	193	1250

Note: option byte 16 is described in Section 3.12.11

3.12.16 Option Byte 17 - PCI Options C

Note: option byte 17 has no hardware equivalent.

Bit Interpretation

7-4 *Unused*

3-0 **Look-ahead Read Termination:**

b3	b2	b1	b0	
0	0	0	0	255 file marks (ie no effective termination)
0	0	0	1	Look-ahead read terminates on every file mark
0	0	1	0	Look-ahead read terminates on 2 consecutive file marks
0	0	1	1	Look-ahead read terminates on 3 consecutive file marks .. and so on ...
1	1	1	1	Look-ahead read terminates on 15 consecutive file marks

BYTE	Bit 7	Bit 6	Bit 5	Bit 4	Bit 3	Bit 2	Bit 1	Bit 0
06 HOST I/F A	EOT LATCHED	OFFLINE, NO REWIND	REJECT FWD AT EOT LIMIT	IMDP CHECKED, IHER IF ERROR	PE/NRZ IMDP WRITTEN	ANALYSE INHIBITED	INRZ SET IF GCR ACTIVE	WRITE AT NEW DENSITY
07 HOST I/F B	GCR < ---	PE FM GAP IS NORMAL	DPE IBG	NRZ > ---	NRZ LRC & CRC, WITH STROBES	GCR ICER IF 2-TRK ERR	AFTER PE ERR, IRSTR'S CONT	-
08 HOST I/F C	-	IFBY CLEARS EARLY	LDG EDGE IGO SETS IFBY	IFEN HIGH RESETS CMD	-	MSB < ---	BIT 1 UNIT ADDRESS	LSB > ---
09 HOST I/F D	3200 IDENT NOT READ	3200 IDENT NOT WRITTEN	IHER & ICER PULSED	BOT IDENT ERROR IGNORED	INV CMD CYCLES IDBY & IFBY	3200 bpi READ ONLY	DEN MISMATCH SETS IHER	NO IDENT ASSUMES 3200
10 'INCOMPLETE' CAUSES	NO R-A-W DATA	BOT DURING READ REV	BOT DURING FILE SCH REV	BLANK TAPE DURING READ	IFEN ASSERTED DURING CMD	-	-	NO ERASE CURRENT
11 'REJECT' CAUSES	-	-	-	FWD CMD AT EOT LIMIT	INVALID COMMAND	REV CMD AT BOT	WRITE TO FP TAPE	SET DEN AWAY FROM BOT
12 IBG SIZE	GCR < --- ---				PE/NRZ Detailed in Section 3.12.7 --- >			
13 MISCELLANEOUS A	REWIND AT SLOWER SPEED	SCSI FITTED	CUSTOMER OPTION	SCSI OPTIONS FROM NVR	ENABLED OPERATOR SPEED SELECTION	PWR-ON = HI	customer option	customer option
14, 15 & 17 SCSI/CACHE BUFFER	See Tables 3.12 (a) - (e)							
16 DENSITY	POWER-UP DEFAULT < --- ---			HOST I/F SELECTION See tables below --- >			HOST I/F CHANGE ENABLED	FRONT PANEL
18 MISCELLANEOUS B	-	-	HIGH DISABLE ON-LINE SPEEDS	LOW	6250 bpi	3200 bpi	1600 bpi	800 bpi DISABLE DENSITIES

Power-up default:

b7	b6	b5	
0	0	x	800 bpi NRZ
0	1	x	1600 bpi PE
1	0	x	3200 bpi DPE
1	1	x	6250 bpi GCR

Host interface selection:

b4	b3	b2	
x	0	x	Standard encoded commands
x	1	x	Option A encoded commands
x	x	0	IHISP PL2/50, IHIDEN PL1/36
x	x	1	IHISP/IHIDEN pins exchanged
1	x	x	Alternate '6250 select' code

Note: functions are as stated when the bit is set to '1'.

TABLE 3.12 BASIC CONFIGURATION OPTIONS

BYTE	Bit 7	Bit 6	Bit 5	Bit 4	Bit 3	Bit 2	Bit 1	Bit 0
13 MISCELLANEOUS A	*	SCSI FITTED	*	SCSI OPTIONS FROM NVR	*	*	*	*
14 SCSI A	PARITY CHECKED	DISCONNECT ENABLED	ATTENTION REPORTING	RECOVERED ERR REPORTING	HIGH SPEED BURST MODE	REM DENSITY SELECTION	ENGINEERING TOOL	PCB NOT ISS A OF 12197X
15 SCSI B	REM SPEED SELECTION	CC ON READ INTO EOT	-	-	LOOK-AHEAD READ	MSB < ---	SCSI ID	LSB --- >
16	*	*	*	*	*	*	*	*
17 SCSI C	-	-	-	-	LOOK-AHEAD READ TERMINATION < --- consecutive file marks, see below --- >			

Note: byte 15 bit 6, function introduced at revision 09

TABLE 3.12 (a) SCSI OPTIONS, PROM 123107 prior to revision 11

BYTE	Bit 7	Bit 6	Bit 5	Bit 4	Bit 3	Bit 2	Bit 1	Bit 0
13 MISCELLANEOUS A	*	SCSI FITTED	*	SCSI OPTIONS FROM NVR	*	*	*	*
14 SCSI A	PARITY CHECKED	DISCONNECT ENABLED	ATTENTION REPORTING	RECOVERED ERR REPORTING	HIGH SPEED BURST MODE	REM DEN/SPEED & BUFFER	ENGINEERING TOOL	PCB NOT ISS A OF 12197X
15 SCSI B	FM STATUS WR/RD/SP	CC ON READ INTO EOT	-	-	LOOK-AHEAD READ	MSB < ---	SCSI ID	LSB --- >
16	*	*	*	*	*	*	*	*
17 SCSI C	-	-	-	-	LOOK-AHEAD READ TERMINATION < --- consecutive file marks, see below --- >			

TABLE 3.12 (b) SCSI OPTIONS, PROM 123107 revisions 11 & 12

Note 1: functions are as stated when the bit is set to '1'

Note 2: '*' means those bits are not specific to SCSI operation

Look-ahead Read termination:

b3	b2	b1	b0	
0	0	0	0	255 file marks (ie none)
0	0	0	1	1 file mark
0	0	1	0	2 file marks
:	:	:	:	and so on
1	1	1	1	15 file marks

BYTE	Bit 7	Bit 6	Bit 5	Bit 4	Bit 3	Bit 2	Bit 1	Bit 0
13 MISCELLANEOUS A	*	SCSI FITTED	*	SCSI OPTIONS FROM NVR	*	*	*	*
14 SCSI A	PARITY CHECKED	DISCONNECT ENABLED	ATTENTION REPORTING	RECOVERED ERR REPORTING	HIGH SPEED BURST MODE	REM DEN/SPEED & BUFFER	CODE COMPATIBILITY	CODE COMPAT
15 SCSI B	FM STATUS WR/RD/SP	CC ON READ INTO EOT	WRITE FAIL STOP BOT SIDE	CODE COMPATIBILITY	LOOK-AHEAD READ	MSB < ---	SCSI ID	LSB --- >
16	*	*	*	*	*	*	*	*
17 SCSI C	-	-	-	-	LOOK-AHEAD READ TERMINATION < --- consecutive file marks, see above --- >			

TABLE 3.12 (c) SCSI OPTIONS, PROM 123107 revision 14
& PROM 123996 revision 01

BYTE	Bit 7	Bit 6	Bit 5	Bit 4	Bit 3	Bit 2	Bit 1	Bit 0
13 MISCELLANEOUS A	*	SCSI FITTED	*	SCSI OPTIONS FROM NVR	*	*	*	*
14 SCSI A	PARITY CHECKED	DISCONNECT ENABLED	ATTENTION REPORTING	RECOVERED ERR REPORTING	HIGH SPEED BURST MODE	CODE COMPATIBILITY	CODE COMPATIBILITY	CODE COMPAT
15 SCSI B	FM STATUS WR/RD/SP	CC ON READ INTO EOT	WRITE FAIL STOP BOT SIDE	CODE COMPATIBILITY	WR EOM IN EW AREA	MSB < ---	SCSI ID	LSB --- >
16	*	*	*	*	*	*	*	*
17 SCSI C	-	-	-	-	LOOK-AHEAD READ TERMINATION < --- consecutive file marks, see above --- >			

TABLE 3.12 (d) SCSI OPTIONS, PROM 123996 revisions 02 & 03

Note 1: functions are as stated when the bit is set to '1'

Note 2: '*' means those bits are not specific to SCSI operation

Code Compatibility (3-bit):

B15 b4 B14 b1 B14 b0

1	0	1	M4 Data std
1	1	0	STK std
other codes			Reserved

Code Compatibility (4-bit):

B15 b4 B14 b2 B14 b1 B14 b0

1	1	1	0	STK standard (rev 02 & 03 PROMS)
0	1	1	1	STK special (rev 03 PROM), see text
other codes				Reserved

BYTE	Bit 7	Bit 6	Bit 5	Bit 4	Bit 3	Bit 2	Bit 1	Bit 0
13 MISCELLANEOUS A	*	PERTEC CACHE FITTED	*	CACHE OPTIONS FROM NVR	*	*	*	*
14 SCSI A	LOWER HOST DATA RATES	LDG EDGE IGO SETS IFBY	PARITY NOT CHECKED	IEOT WHEN MARKER SEEN	RETRY COUNT		CACHE MODE CONTROL	
15 SCSI B	-	CODE COMPATIBILITY		ELECTRONIC RAMP DELAY		HOST DATA RATE		
16	*	*	*	*	*	*	*	*
17 SCSI C	-	-	-	-	LOOK-AHEAD READ TERMINATION < --- consecutive file marks, see below --- >			

Retry count:

b3	b2	
0	0	0 write/ 4 read
0	1	16 write/ 4 read
1	0	32 write/ 8 read
1	1	48 write/12 read

Cache mode control:

b1	b0	
0	0	Normal cache (2)
0	1	Non-cache (1)
1	0	Reserved
1	1	Non-cache, long block (4)

Code compatibility:

b6	b5	
0	0	M4 Data std emulation
0	1	STK 2920 emulation
1	0	QT14 emulation
1	1	M4's 9905 emulation

Electronic ramp delay:

b4	b3	
0	0	0 ms
0	1	2 ms
1	0	4 ms
1	1	8 ms (read) 120 ms (write)

Host Data Rate (kB/s):

b2	b1	b0	Lo/ Hi
0	0	0	10/ 278
0	0	1	30/ 312
0	1	0	50/ 357
0	1	1	72/ 416
1	0	0	100/ 500
1	0	1	120/ 625
1	1	0	156/ 833
1	1	1	193/1250

Look-ahead Read termination:

b3	b2	b1	b0	
0	0	0	0	255 file marks
0	0	0	1	1 file mark
0	0	1	0	2 file marks
.	.	.	.	and so on
1	1	1	1	15 file marks

Note 1: functions are as stated when the bit is set to '1'.
 Note 2: '*' means those bits are not specific to cache operation.

TABLE 3.12 (e) PERTEC CACHE OPTIONS

3.13 FULL STATUS BYTES

A set of status bytes is available as an extension of the normal status signals at the Pertec interface. These bytes can be examined at the operator display (using diagnostic program 68), accessed via the Pertec interface (using 'access full/condensed status byte block' commands) or via the SCSI interface (using the 'receive diagnostic results' command).

The full status byte block consists of 16 8-bit bytes, while the condensed status byte block consists of 9 8-bit bytes. The following sections describe the actions which initialise each block and list the functions of the various constituent bits. The status bytes are tabulated at the end of each descriptive list.

Status Byte Initialisation

The status bytes are cleared, or set, under the circumstances described below.

Power-up	Clears most bytes, except F15, F16 (& C9) which are set according to the configuration options.
Tape Motion	Acceptance of a tape motion interface command clears bytes F5 to F12.
Diagnostic Program 69	Clears most bytes, except F15 (& C9) which are set according to the currently selected density.

3.13.1 Status Byte F1

All on-line write hard and correctable errors are logged in status byte F1. Bit 0 is the least significant bit.

3.13.2 Status Byte F2

All on-line hard read errors are counted in status byte F2. Bit 0 is the least significant bit.

3.13.3 Status Byte F3

When a diagnostic program is called across the interface, its number (in bits 0 to 4, bit 0 being the least significant bit) is logged in status byte F3. If 'skip on failure' is not set, F3 therefore reflects the failed program number (and F4 contains the failure code).

When a diagnostic program is called from the control panel, its number (in bits 0 to 6) is always logged in status byte F3.

3.13.4 Status Byte F4

When an on-line diagnostic test fails, status byte F4 contains the error code associated with status byte F3 (zero denotes no error).

When the 9914 is off-line, status byte F4 contains the error count when 'failure skip' (invoked by diagnostic program 17) is active.

In either case, bit 0 is the least significant bit.

3.13.5 Status Byte F5

When on-line, status byte F5 contains track-in-error information which may be useful when a single-track error has been reported. A single-track error with no bit set in status byte F4 indicates a parity track error. Bit 7 corresponds to track 7, through to bit 0 corresponding to track 0.

3.13.6 Status Byte F6

Status byte F6 should be examined after a hard error has been reported.

The interpretation of each bit depends on the current density setting.

(a) Status byte F6, definitions for GCR and PE densities:

<i>Bit</i>	<i>Name</i>	<i>Meaning</i>
7	NRZ	Status byte F6 has GCR/PE meaning when this bit is zero; ie NRZ density is not active.
6	IDENT FOUND	Identification found. This bit is set if a properly formatted GCR/PE ident burst or ARA burst or ARA ident is found during any read forward operation which expects a properly formatted data block.
5	CER	Corrected error status; this does not set the Pertec interface IHER line, error correction has taken place.
4	VPE	Vertical parity error with no single-track dropout.
3	SKEW	Greater than 8 bits of track-to-track data skew detected.
2	MTE	Uncorrectable multiple track dropout. Note: GCR encoding enables the correction of two-track errors.
1	FALSE POSTAMBLE	False postamble detected.
0	FALSE PREAMBLE	False preamble detected, this also sets the false postamble bit.

(b) Status byte F6, definitions for NRZ density:

<i>Bit</i>	<i>Name</i>	<i>Meaning</i>
7	NRZ	Status byte F6 has NRZ meaning when this bit is set; ie NRZ density is active.
6 - 3	-	-
2	LRCE	Longitudinal redundancy check error.
1	CRCE	Cyclic redundancy check error.
0	VPE	Vertical parity error.

Status byte F7 contains supplementary error and status information which should be read in conjunction with status byte F6.

<i>Bit</i>	<i>Name</i>	<i>Meaning</i>
7	REJECT	The 9914 was unable to accept a command, further detail may be gained by referring to status byte F9 (<i>note: accessing only the condensed status byte block will not reveal the cause</i>).
6	INCOMPLETE	The 9914 accepted a command, but was unable to complete in the manner expected; the reasons are flagged in status byte F8. <i>Note: following this error, the tape may be positioned incorrectly for the next operation.</i>
5	EOT LIMIT	Set when the tape has passed well beyond the EOT reflective marker in the forward direction. Further forward tape motion is inhibited (by a configuration option) because of the possibility of running to the physical end of tape. The user should ensure that data is not lost when tape moves beyond EOT limit.
4	EARLY EOT	Sets when the tape is approaching the EOT tab, remains set while the tape is beyond EOT. 'Early EOT' is used by the SCSI and PCI to control the data buffer.
3	DENSITY ERROR	An error has been found in the density ident area, the reason is expanded in status byte F10.
2	EOT	Set when the tape has passed the EOT reflective marker in the forward direction, clears when the EOT marker is detected in the reverse direction.
1	FILE MARK LAST BLOCK	The last block traversed had file mark status.
0	INTERFACE WRT PARITY	Interface write parity; sets if the 'external write parity' option is set, and a parity error is detected on the interface 'write data' lines (IWD0 - IWD7).

3.13.8 Status Byte F8

Status byte F8 expands the INCOMPLETE bit of status byte F7.

<i>Bit</i>	<i>Name</i>	<i>Meaning</i>
7	RWFAIL	No read-after-write data was detected during a write operation. The operation was terminated and the INCOMPLETE bit set.
6	RRD BOT	BOT was detected prior to, or during, a 'read reverse' or 'space reverse' operation.
5	FSR BOT	BOT was detected prior to the first file mark during a 'file search reverse' operation.
4	BLANK TAPE	More than 30 ft (9 m) of tape were traversed without encountering any data during a forward 'read', 'file search', or 'space' operation.
3	IFEN	The interface IFEN signal was activated during an operation.
2 & 1	-	-
0	NOT WRITING	No current was sensed in the erase head, during a 'write' or 'erase' operation.

3.13.9 Status Byte F9

Status byte F9 expands the REJECT bit of status byte F7.

<i>Bit</i>	<i>Name</i>	<i>Meaning</i>
7 - 5	-	-
4	EOTLIM CMD	A forward command was received while the tape was beyond the EOT limit.
3	INV CMD	The command code was not recognised (ie an illegal combination).
2	REV @ BOT	A reverse motion command (other than rewind) was received at BOT.
1	WRT FPTD	A write command was received, but the tape is not write enabled.
0	DENS /BOT	A density change was attempted, but the tape was not at BOT.

3.13.10 Status Byte F10

Status byte F10 expands the DENSITY ERROR bit of status byte F7.

<i>Bit</i>	<i>Name</i>	<i>Meaning</i>
7	NO IDENT	(GCR/PE only) No ident burst was detected during a read from BOT by the time the BOT tab had traversed the head.
6	NO ARA	(GCR only) No ARA burst was detected during a read from BOT, but the ident burst was detected.
5	NO ARA ID	(GCR only) No ARA ident was detected during a read from BOT, but the ident and ARA bursts were detected.
4	-	-
3	IDENT WRT	(GCR/PE only) It was not possible to write a continuous identifier to tape during a write operation from BOT.
2	ARA WRT	(GCR only) It was not possible to write a correctly formatted ARA burst without error during a write operation from BOT.
1	ARA ID WRT	(GCR only) It was not possible to write a correctly formatted ARA ident without error during a write operation from BOT.
0	CONFIG	Configuration error; sets if a 'set density' command is received and an error is detected while attempting to configure to the new density.

3.13.11 Status Byte F11

Status byte F11 expands some GCR errors.

<i>Bit</i>	<i>Name</i>	<i>Meaning</i>
7	ACRC	Error in the auxiliary CRC character.
6	CRC	Error in the CRC character.
5	UNCER	Uncorrectable error.
4	2-TRACK ERROR	Two-track error correction performed.
3	1-TRACK ERROR	Single-track error correction performed.
2	CRC GROUP ERROR	One or more of the CRC characters in the CRC group is incorrect. If the CRC bit is not set, then the first character of the group is correct and therefore the data is almost certainly correct.
1	RCHAR ERROR	Residual character error.
0	PCHAR ERROR	Padding character error.

3.13.12 Status Byte F12

Status byte F12 contains the detail of some GCR errors.

Bit	Name	Meaning
7 - 4	-	-
3	FORMAT ERROR 1	MARK 1 was not found at the start of the data groups.
2	FORMAT ERROR 2	MARK 2 was not found when expected.
1	NOT SYNCH	At least one track was not synchronised.
0		

3.13.13 Status Byte F13

This byte refers to GCR status, reserved for future use.

3.13.14 Status Byte F14

Bit	Name	Meaning
7	DENS SET 0	Encoded with bit 6 to denote the derivation of the density setting.
6	DENS SET 1	Encoded with bit 7:

Bit 7	Bit 6	Meaning
0	0	Density recognised during analyse.
0	1	Default density, analyse detected blank tape.
1	0	Default density, analyse detected unrecognisable format.

5 - 2	-	-
1	DENSITY MISMATCH	Set if a read command follows a 'set density' command which altered the density concluded by the analyse function at load time.
0	-	-

3.13.15 Status Byte F15

Bit	Name	Meaning
7 & 6	DENSITY SELECTED	Encoded to denote which density is currently selected:

Bit 7	Bit 6	Density
0	0	1600 bpi PE
0	1	3200 bpi DPE
1	0	800 bpi NRZ
1	1	6250 bpi GCR

5 & 4	-	-
3	GCR	6250 bpi GCR available.
2	NRZ	800 bpi NRZ available.
1	3200	3200 bpi DPE available.
0	1600	1600 bpi PE available.

3.13.16 Status Byte F16

Bit	Name	Meaning
7 - 4	MODEL	Encoded to denote the base model type. Note: these type numbers refer to <i>M4 Data</i> models.

Bit 7	Bit 6	Bit 5	Bit 4	Model
0	0	0	0	9800
0	0	0	1	9903
0	0	1	0	8900
0	0	1	1	8924
0	1	0	0	9913
0	1	0	1	9914

3 & 2	-	-
1	SCSI (or PCI) FITTED	The embedded 9914 SCSI interface is fitted, <i>or</i> the embedded Pertec Cache Interface is fitted.
0	-	-

3.13.17 Status Byte F17

This byte is reserved for future use.

READ DATA LINE BYTE	IRD7	IRD6	IRD5	IRD4	IRD3	IRD2	IRD1	IRD0
F1 - WRITE ERROR LOG (total IHER & ICER)	2 ⁷	2 ⁶	2 ⁵	2 ⁴	2 ³	2 ²	2 ¹	2 ⁰
F2 - READ ERROR LOG (IHER only)	2 ⁷	2 ⁶	2 ⁵	2 ⁴	2 ³	2 ²	2 ¹	2 ⁰
F3 - DIAGNOSTIC PROGRAM NUMBER	-	2 ⁶	2 ⁵	2 ⁴	2 ³	2 ²	2 ¹	2 ⁰
F4 - DIAGNOSTIC ERROR CODE or LOOP COUNT	2 ⁷	2 ⁶	2 ⁵	2 ⁴	2 ³	2 ²	2 ¹	2 ⁰
F5 - TRACK IN ERROR (PE only)	TIE 7	TIE 6	TIE 5	TIE 4	TIE 3	TIE 2	TIE 1	TIE 0
F6 - HARD ERROR CONDITION (PE/GCR)	0 (always)	IDENT FOUND	CER	VPE	SKEW	MTE	FALSE POSTAMBLE	FALSE PREAMBLE
F6 - HARD ERROR CONDITION (NRZ)	1 (always)	-	-	-	-	LRCE	CRCE	VPE
F7 - SUPPLEMENT TO F6	REJECT	INCOMPLETE	EOT LIMIT	EARLY EOT	DENSITY ERROR	EOT	FILE MARK LAST BLOCK	INTERFACE WRT PARITY
F8 - EXPANSION OF 'INCOMPLETE' BIT	RWFAIL	RRD BOT	FSR BOT	BLANK TAPE	IFEN	-	-	NOT WRITING
F9 - EXPANSION OF 'REJECT' BIT	-	-	-	EOTLIM CMD	INV CMD	REV 0 BOT	WRT FPTD	DENS /BOT

TABLE 3.13 (a) FULL STATUS BYTES, F1 to F9

continued . . .

... continued

READ DATA LINE BYTE	IRD7	IRD6	IRD5	IRD4	IRD3	IRD2	IRD1	IRD0
F10 - EXP OF 'DENSITY' BIT (these set IHER)	NO IDENT	NO ARA	NO ARA ID	-	IDENT WRT	ARA WRT	ARA ID WRT	CONFIG
F11 - GCR STATUS 1 (these set IHER/ICER)	ACRC	CRC	UNCER	2-TRACK ERROR	1-TRACK ERROR	CRC GROUP ERROR	RCHAR ERROR	PCHAR ERROR
F12 - GCR STATUS 2 (these set IHER)	-	-	-	-	FORMAT ERROR 1	FORMAT ERROR 2	NOT SYNCH	-
F13 - Reserved	-	-	-	-	-	-	-	-
F14	DENS SET 0 (see below)	DENS SET 1 (see below)	-	-	-	-	DENSITY MISMATCH	-
F15 - IDENT BYTE 1	DENSITY SELECTED (see below)		-	-	6250 bpi	800 bpi	3200 bpi	1600 bpi
F16 - IDENT BYTE 2	BASE MODEL TYPE (see Section 3.13.16)				-	-	SCSI (or PCI) FITTED	Reserved
F17 - Reserved	-	-	-	-	-	-	-	-

Byte F14 encoding:

IRD7	IRD6	
0	0	Analyse found known density
0	1	Default density, blank tape
1	0	Default density, alien format
1	1	No assigned meaning

Byte F15 encoding:

IRD7	IRD6	
0	0	1600 bpi PE
0	1	3200 bpi PE
1	0	800 bpi NRZ
1	1	6250 bpi GCR

TABLE 3.13 (b) FULL STATUS BYTES, F10 to F17

3.14 CONDENSED STATUS BYTES

Condensed status bytes C1 to C9 are almost identical in content and function to analogous full status bytes.

Condensed Status Byte	Full Status Byte	Old Status Byte
C1	F1	A
C2	F2	B
C3	F3	C
C4	F4	D
C5	F5	E
C6	F6	F
C7	(F7)	G
C8	<i>None</i>	-
C9	(F15)	I

The 9914 status bytes C1 to C9 are near equivalents to sense bytes A to I from the older *M4 Data* 8900/9800/9903/9905 series of streamers.

Note however that status bytes C7 and C9 are not a one-for-one copies of status bytes F7 and F15, these bytes are outlined in the next sections and tabulated at the end of the outlines.

3.14.1 Status Byte C7

Bit	Name	Meaning
7	RWFAIL	As status byte F8, bit 7.
6	INCOMPLETE	As status byte F7, bit 6.
5	REJECT	As status byte F7, bit 7.
4	BLANK TAPE	As status byte F8, bit 4.
3	DENSITY ERROR	As status byte F7, bit 3.
2	EOT	As status byte F7, bit 2.
1	FILE MARK LAST BLOCK	As status byte F7, bit 1.
0	NOT WRITING	As status byte F8, bit 0.

3.14.2 Status Byte C8

Bit	Name	Meaning
7 & 6	DENS SET X	As status byte F14, bits 7 & 6.
5 - 2	-	-
1	DENSITY MISMATCH	As status byte F14, bits 7 & 6.
0	INTERFACE WRT PARITY	As status byte F7, bit 0.

3.14.3 Status Byte C9

Bit	Name	Meaning
7 & 6	DENSITY SELECTED	As status byte F15, bits 7 and 6.
5	EOT LIMIT	As status byte F7, bit 5.
4	-	As status byte F7, bit 4.
3 - 0	DENSITIES AVAILABLE	As status byte F15, bits 3 to 0.

READ DATA LINE BYTE	IRD7	IRD6	IRD5	IRD4	IRD3	IRD2	IRD1	IRD0
C1 - WRITE ERROR LOG (total IHER & ICER)	2 ⁷	2 ⁶	2 ⁵	2 ⁴	2 ³	2 ²	2 ¹	2 ⁰
C2 - READ ERROR LOG (IHER only)	2 ⁷	2 ⁶	2 ⁵	2 ⁴	2 ³	2 ²	2 ¹	2 ⁰
C3 - DIAGNOSTIC PROGRAM NUMBER	-	2 ⁶	2 ⁵	2 ⁴	2 ³	2 ²	2 ¹	2 ⁰
C4 - DIAGNOSTIC ERROR CODE or LOOP COUNT	2 ⁷	2 ⁶	2 ⁵	2 ⁴	2 ³	2 ²	2 ¹	2 ⁰
C5 - TRACK IN ERROR (PE only)	TIE 7	TIE 6	TIE 5	TIE 4	TIE 3	TIE 2	TIE 1	TIE 0
C6 - HARD ERROR COND (PE/GCR)	0 (always)	IDENT FOUND	CER	VPE	SKEW	MTE	FALSE POSTAMBLE	FALSE PREAMBLE
C6 - HARD ERROR COND (NRZ)	1 (always)	-	-	-	-	LRCE	CRCE	VPE
C7 - SUPPLEMENT TO C6	RWFAIL	INCOMPLETE	REJECT	BLANK TAPE	DENSITY ERROR	EOT	FILE MARK LAST BLOCK	NOT WRITING
C8 - EXTRA STATUS	DENS SET 0	DENS SET 1	-	-	-	-	DENSITY MISMATCH	INTERFACE WRT PARITY
C9 - DENSITIES	DENSITY SELECTED (see byte F15)		EOT LIMIT	EARLY EOT	6250 bpi	800 bpi	3200 bpi	1600 bpi
						(densities available)		

TABLE 3.14 CONDENSED STATUS BYTES

CHAPTER 4 - SUB-ASSEMBLIES

<i>CONTENTS</i>	<i>Page</i>
4.0 SCOPE OF CHAPTER 4	1
4.1 SERVICE EQUIPMENT AND PROCEDURES	1
4.2 MAINS TRANSFORMER AND SWITCH	4
4.3 POWER SUPPLY BOARD	7
4.4 SERVO CONTROL BOARD	9
4.5 CONTROLS AND INDICATORS	10
4.6 SUPPLY HUB	12
4.7 REEL MOTORS	18
4.8 TAPE PATH ASSEMBLY	19
4.9 TAPE CLEANER	20
4.10 TAPE PATH ROLLERS	21
4.11 TENSION ARM ASSEMBLY	22
4.12 DATA CONTROL BOARD	23
4.13 ANALOGUE DATA PATHS BOARD	24
4.14 DIGITAL DATA PATHS BOARD	25
4.15 SCSI BOARD	26
4.16 COOLING FAN	27
4.17 PERTEC CACHE INTERFACE BOARD	28

4.0 SCOPE OF CHAPTER 4

This Chapter provides sufficient information to familiarise a service engineer with the streamer sub-assemblies; each sub-assembly occupies its own section and is divided into sub-sections under the titles:

- function;
- location;
- checkout;
- setting/re-calibration;
- removal and replacement.

Fault finding procedures, system settings, and diagnostic aids are provided in Chapter 3.
Functional descriptions are provided in Chapter 2.

4.1 SERVICE EQUIPMENT AND PROCEDURES

4.1.1 General Notes:

- most screws used throughout the 9914 are UNC;
- for removal of some sub-assemblies it is necessary to cut the cable tie wrap. A fresh tie wrap must be fitted after replacement has been effected;
- for removal of some sub-assemblies it is necessary to disconnect earth bonding straps. These may appear to perform no electrical function, but they must be re-connected in order to maintain good protection against electro-static discharge;
- sub-assembly locations are illustrated in Chapter 5.

4.1.2 ESD Precautions

9914 sub-assemblies contain electronic components which use Metal Oxide Silicon (MOS) technology. Such components are more sensitive to Electro Static Discharge (ESD) than the older bipolar technology components, and should be treated with special precautions to avoid damage and subsequent circuit failure.

Servicing personnel should be familiar with the general principles of ESD precautions, which are stated next.

- Anyone handling ESD sensitive components should avoid wearing Nylon clothing (cotton is preferred), and stand on an anti-static mat.
- Anyone removing, handling, re-working, or replacing ESD sensitive sub-assemblies should be grounded by a conductive wrist strap.
- Circuit boards should only be handled by their edges, be stored in anti-static bags, and not be allowed to slide over any surface.
- Freshly photocopied documents may have considerable static build-up, therefore they should not be introduced into board handling areas.

4.1.3.1 Electrical Servicing Equipment

- (a) Moving coil multimeter,
dc voltages from 100 mV fsd to 50 V fsd.
dc current from 100 mA to 10 A.
ac voltages from 5 V to 250 V.
- (b) Dual trace oscilloscope,
bandwidth not less than dc to 50 MHz
time base 500 ns/cm - 0.1 s/cm
X10 and X1 probes.
- (c) Digital frequency counter,
up to 1 MHz.

4.1.3.2 Mechanical Servicing Equipment

- (a) Spring Balance (0-0.5 N, 0-1 lb).
- (b) Camera Lens Cleaner (rubber bulb puffer).
- (c) Sets of Allen Keys
(Imperial 1/16" to 1/4" AF, in 1/32" steps), preferably with a screwdriver handle, 3/32" must have screwdriver handle.
- (d) Screwdrivers: flat small; flat medium; pozidrive 0, 1 and 2 points
(2 point should be 100 mm long).
- (e) Potentiometer Adjustment Tool.
- (f) Tape Path Cleaning Materials,
Freon TF, Arklone P, or Safeclean, and a lint-free cloth.
- (g) Supply Hub Height Setting Tool, T6009/14.
- (h) Take-up Hub Height Setting Tool, T6007.
- (i) Universal Hub Puller Tool, T6037.

4.1.3.3 Tapes

- (a) Work Tape. A good quality tape known to have no data 'drop-outs'. The tape should not contain data of any consequence so as to be available for write checks/tests. The supply reel must be fitted with a 'write enable' ring.
- (b) Master Alignment (Skew) Reference Tape.
IBM Reference 432640 (600 ft),
available from Pericom.
- (c) Master Amplitude Reference Tape. IBM Reference 432152,
available from Graham Magnetics.
- (d) Length of tape (approximately 300 mm (12 in)), with loops, which will pass over rollers, formed at each end using adhesive tape.
- (e) A special tape, fitted with an EOT marker positioned 5 cm (2 in) from a BOT marker (NOT back-coated tape).
- (f) A good quality tape, free from edge damage and known to track correctly, to be used exclusively for tape path checks/settings (see Section 4.13).
- (g) Reel of adhesive reflective tape markers 6.5 x 25.4 mm (0.25 in x 1 in)
(eg as manufactured by 3M under the 'Scotch' brand name).

4.1.4 Settings After FRU Replacement

If a major FRU is replaced, there may be checks or adjustments before full operational performance is restored:

Board replaced	Checkout	Adjustments
Servo Control	Diagnostic program 04	None
Data Control	Link options (Chapter 3) NVR values (program 80) Re-calibrate (program 74) Configuration options (Chapter 3) Power cycle	None
Analogue Data Paths	Re-calibrate (Chapter 3)	Issue 1 boards only, reset the monostables
Digital Data Paths	None	None
Power Supply	Outputs (Section 4.3)	None
Switch facia	None	None
Tape Path assembly	Re-calibrate (Chapter 3)	None
Mother board	None	None

TABLE 4.1.4 SETTINGS AFTER FRU REPLACEMENT

4.2 MAINS TRANSFORMER AND SWITCH

4.2.1 Function

The mains transformer incorporates tapped input windings so that the specified range of input ac supply voltages can be accommodated.

Secondary windings enable the Power Supply board to convert and regulate various dc voltages for internal use.

The single-pole mains switch is connected into the primary of the mains supply to the mains transformer; when set 'off', it therefore disconnects the live line from the Mains Transformer.

4.2.2 Location

The mains transformer is located immediately to the left side of the card cage, at the rear of the streamer.

The mains switch is located on the lower right of the front moulding, and is marked with '0' & '1' designations.

4.2.3 Checkout

If there is no activity on the operator's display, and no sound of the cooling fan running, with the 9914 switched 'on', the dc outputs from the Power Supply may be absent, suggesting that the mains fuse (FS1) at the rear of the streamer may have blown or the mains supply has failed.

The transformer low voltage outputs appear at a 10-way socket (P1) on the Power Supply pcb in the base of the streamer; these voltages at nominal mains input are tabulated in Table 4.2.3, no tolerances are given because these outputs are likely to be either present or absent.

Between pins	AC voltage
4 and 5	9.2
4 and 6	9.2
7 and 8	36
2 and 3	15
1 and 3	15

TABLE 4.2.3 MAINS TRANSFORMER VOLTAGES TO PSU

4.2.4 Setting

The only setting associated with the mains transformer is the input voltage selection.

Ensure that the input voltage selection setting is compatible with the site supply voltage. Four ac settings are possible, 100/120 V or 220/240 V, the input frequency may be between 48 and 62 Hz.

Note: when the 9914 is to be connected to a 110 V supply, use the 100 V input setting.

To change the voltage selection:

- (i) Set power off and UNPLUG THE MAINS LEAD AT THE REAR OF THE 9914;
- (ii) (see Figure 4.2.1) insert a flat-bladed (5 mm) screwdriver where illustrated and hinge the panel open;
- (iii) withdraw the barrel-shaped voltage selector mechanism and re-insert with the new voltage facing outwards, do not attempt to rotate the selector barrel in-situ;
- (iv) withdraw the fuse holder and install the new fuse, rated as follows:

for 100/120 V settings, FS1 is a 4 A slow-blow fuse (eg Littelfuse type 313);
for 220/240 V settings, FS1 is a 2 A slow-blow fuse (eg Littelfuse type 313).

Notes regarding the supply and the supply cable:

- (i) The moulded socket on the supply lead fits a chassis-mounted plug located at the rear of the 9914. A suitable 3-pin plug must be connected to the supply lead; 2-pin plugs are not suitable because the earth wire must be 'grounded' for safety reasons.
- (ii) The 9914 must not be connected to an I.T. mains system, which is defined as one where the neutral line is held at a substantially different voltage to the earth line.

(iii) The colour coding of the individual cables is:

LIVE	Brown
NEUTRAL	Blue
EARTH	Green/Yellow
LIGNE	Brun
NEUTRE	Bleu
TERRE	Vert/Jaune
POSITIV	Braun
NEGATIV	Blau
ERDE	Gelb/Grün

The wiring of US 3-pin plugs is:

LIVE (Brown)	= Black (US) - flat gold pin
NEUTRAL (Blue)	= White (US) - flat silver pin
EARTH (Green/Yellow)	= Green (US) - half-round gold pin

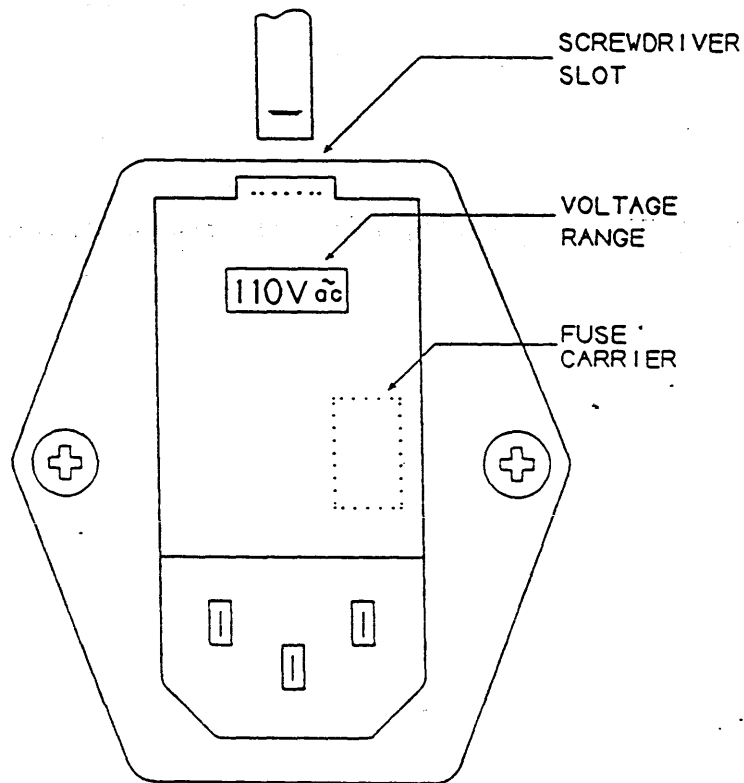

FIGURE 4.2.1 VOLTAGE SELECTION

4.2.5 Removal and Replacement

The mains transformer should be removed together with the voltage selection panel, as one complete assembly. The removal procedure is:

- (i) Unload and remove the reel of tape.

- (ii) Set power off and UNPLUG THE MAINS LEAD AT THE REAR OF THE 9914.
- (iii) If the 9914 is a desk-top model, note the connection of any earth bonding straps and remove the covers to improve access and prevent damage to the paint finish.
- (iv) Remove the card cage cover.
- (v) Remove all cards from the card cage.
- (vii) Disconnect the 10-way socket (P1) at the PSU and unthread the cableform back to the transformer.
- (viii) Remove the back panel of the 9914.
- (ix) With the unit open, remove the left card cage fixing screws (at the front of the bulkhead); ease out the combined transformer and input socket as one assembly.
- (x) Remove the strengthening bracket connecting the transformer to the base tray.

When replacing the transformer assembly, reverse the removal procedure and check that the voltage selection, FS1 fuse rating (see Section 4.2.4 - Setting) and voltage label are correct for the installation.

If the streamer is a desk-top model, take care to re-connect the earth bonding straps from the covers, to maintain good ESD performance.

After all the connections have been made, switch on and check that the display indicates OK after several seconds; if otherwise, Section 3 details the possible fault indications.

The mains switch may removed without disturbing other components, the procedure is:

- (i) Set power off and UNPLUG THE MAINS LEAD AT THE REAR OF THE 9914.
- (ii) Raise the front moulding to its fullest extent (to near vertical), ensure that the safety catch on the gas strut is engaged.
- (iii) Remove the push-on connections at the mains switch, and push the switch retaining ears inwards to release the switch.

When replacing the mains switch, CHECK THAT THE MAINS LEAD AT THE REAR OF THE 9914 IS UNPLUGGED. Reverse the removal procedure, ensuring that the switch is inserted into the front moulding with the '1' legend towards the right side of the 9914 (ie the two connectors outermost).

4.3. POWER SUPPLY BOARD

4.3.1 Function

The ac Power Supply board accepts ac voltages from secondary side of the mains transformer and (using a mixture of switching and linear regulation) generates all the internal dc voltages so that the pcb's receive:

+48 V	unregulated
+24 V	±1.5v semi-regulated
+12 V	±0.5V
+ 5 V	-0 +0.25V
- 5 V	±0.2V
- 6 V	±0.3V
-12 V	±0.5V

4.3.2 Location

The Power Supply board is mounted on spigots in the base tray, as illustrated in Chapter 5.

4.3.3 Checkout

When power is switched on, the existence of critical dc voltages is automatically checked out by the Servo Control processor; in the event of failure (other than +5 V) the POWER message appears on the display.

When a go/no-go test of voltage levels is all that is required, it is only necessary to run diagnostic program 73, which checks essential voltage levels, as outlined in Section 3.4.

If a precise check is needed, the voltages can be checked at the Power Supply board itself (see Chapter 2).

The operator panel does not function (ie the display remains blank) if the +5V rail is not present, check that the operator panel cable is plugged in at the Servo Control board before testing for the presence of +5V at the Power Supply board.

The Power Supply fuses are shown in a component location drawing in Chapter 2.

4.3.4 Setting

After replacement of the Power Supply board, run diagnostic program 73 to check the presence of the internal dc rails.

No output rail has any setting potentiometer or select-on-test component, where close regulation is necessary, the design uses feedback circuits to maintain the required output voltage.

4.3.5 Removal and Replacement

Note: the Power Supply board should be treated as ESD sensitive, see Section 4.1.2.

- (i) Set power off and UNPLUG THE MAINS LEAD AT THE REAR OF THE 9914.
- (ii) Raise the front moulding (and deck casting) to its full extent (almost vertical), ensure that the safety catch on the gas strut is engaged.
- (iii) Release connectors as follows:
 - 13-way (SK1) to the motherboard;
 - 8-way (SK2) to the motherboard;
 - 7-way flying lead to the Servo board P8;
 - 14-way flying lead to the Servo board P7;
 - 10-way (P1) to the mains transformer;
 - the earth spade terminal near FS1.
- (iv) Unscrew the 2 heatsink securing screws, release the Power Supply board by lifting it off the 3 locating spigots which secure it to the base tray.

When replacing the Power Supply, reverse the above removal procedure until all the connectors are in place, then power up and check that the display indicates OK after a few seconds; if otherwise, Section 3 details the possible fault indications.

4.4 SERVO CONTROL BOARD

4.4.1 Function

The Servo Control board controls all tape motion, a circuit description appears in Chapter 2.

4.4.2 Location

The Servo Control board is mounted on spigots in the base tray, as illustrated in Chapter 5.

4.4.3 Checkout

A reasonable checkout of the Servo Control board involves loading a scratch tape to BOT and running diagnostic program 04; this procedure assumes that other sub-assemblies (obviously including the operator panel) are fully functional; but the Data Control, Analogue Data Paths, Digital Data Paths, and pre-amplifier boards need not be installed or fully functional.

Diagnostic program 04 is an automatic checkout of the servo performance, to pre-determined limits. Diagnostic program 49 is a series of input stimuli which exercise the motor drive circuits while an oscilloscope is used to examine the circuit response.

If the Servo Control board has not previously been installed in this machine, run diagnostic program 04 and, if it fails, run diagnostic program 49.

4.4.4 Setting

The Servo Control performance may be checked by running diagnostic program 49, there are no adjustments in the servo control loops.

4.4.5 Removal and Replacement

Note: the Servo Control board is ESD sensitive, see Section 4.1.2 for handling precautions.

- (i) Set power off and UNPLUG THE MAINS LEAD AT THE REAR OF THE 9914.
- (ii) Raise the front moulding (and deck casting) to it's full extent (almost vertical), ensure that the safety catch on the gas strut is engaged.
- (iii) Release connectors as follows:
 - 30-way (P4) to the motherboard;
 - 5-way (P3) to the cooling fan;
 - 5-way (P1) to the TU motor;
 - 5-way (P2) to the SU motor;
 - 7-way (P8) to the Power Supply board;
 - 14-way (P7) to the Power Supply board;
 - 38-way (P5) to the in-chute sensor board;
 - 50-way (P6) to the operator panel.
- (iv) Release the Servo Control board by lifting it off the 4 locating spigots which secure it to the base tray.

When replacing the Servo Control board, reverse the above removal procedure until all the connectors are in place, then power up and check that the display indicates OK after a few seconds; if otherwise, Section 3 details the possible fault indications.

4.5 CONTROLS AND INDICATORS

4.5.1 Function

The operator panel consists of a membrane panel mounted on the front face of the 9914 front moulding, and a set of LED displays which illuminate the legends from behind. The membrane panel includes five switches (usually called 'buttons') used by the operator to control the streamer, and the legends of the four back-lit indicators which show permanent status to the operator. The 8-character display (which shows temporary status messages to the operator) and illuminators for the back-lit status legends are mounted on a common pcb, control and power for this pcb is derived from the Servo Control board.

The buttons and legends are laid out as shown in Figure 4.5.1.

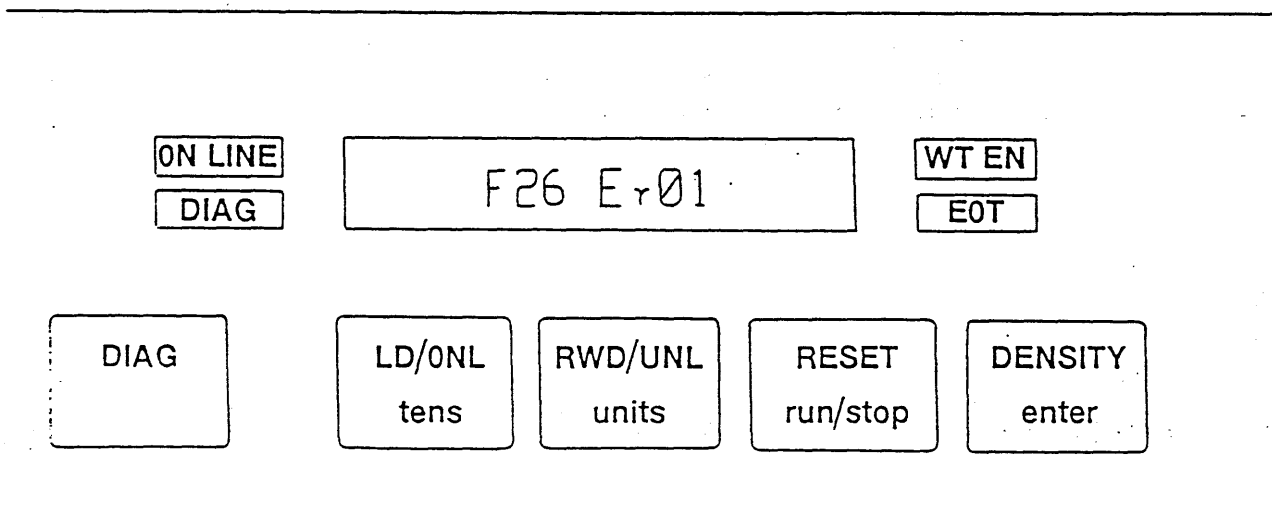

FIGURE 4.5.1 OPERATOR PANEL BUTTONS AND INDICATORS

4.5.2 Location

The operator panel pcb is mounted behind the front moulding on the right hand side (as illustrated in Chapter 5) and connected to the Servo Control board by an 80 cm long, 50-way ribbon cable fixed at the operator panel end and plug-in at the Servo Control board end.

4.5.3 Checkout

In order for the operator panel to function it must receive +5V from the Servo Control board, if the 8-character display is blank with power switched on, the Power Supply may be faulty, refer to Section 4.3.3.

The 8-character display and the back-lit legends may be checked by running diagnostic program 72, which illuminates all parts of the display panel in turn.

The control buttons can be checked out by invoking their functions and verifying the response (with a known good Servo Control board installed) a recommended procedure is to follow Table 4.5.3 in sequence.

Function checked	Action	Correct response
<i>Power-on sequence, DIAG legend</i>	Switch on, wait for a few seconds	DIAG legend flashes, then display shows Testing
RESET button	Press RESET twice	Display shows 'OK'
DIAG button	Press DIAG button	DIAG legend illuminates (display shows Test 00)
'tens' & 'units' buttons	Momentarily depress each button, until 'Test 72' is displayed	Display increments, once per depression
'run/stop' button & 8-char display	Press 'run/stop' once	Display continuously scrolls the 'quick brown fox' message, and illuminates each legend
'enter' button	Press 'enter' once	Display shows 'Enter 72'
<i>Suspend diagnostic</i>	Press 'run/stop' once	Display reverts to 'Test 72'
<i>Exit diagnostic mode</i>	Press DIAG once	Display reverts to OK

TABLE 4.5.3 OPERATOR PANEL BUTTONS CHECKOUT

Notes to Table 4.5.3:

- dual-function buttons are only checked in one function, because interpretation of the input takes place at the Servo Control board;
- functions shown in italics are not specifically operator panel functions, but are a necessary step towards some test pre-condition;
- the Servo Control to operator panel signal paths are listed in Chapter 2;
- more detailed instructions for operating diagnostic programs is set out in the 9914 User/Diagnostic Manual.

4.5.4 Setting

There are no electrical or mechanical settings associated with the operator panel or the signals which drive it.

4.5.5 Removal and Replacement

Note: the operator panel is ESD sensitive, see Section 4.1.2 for handling precautions.

- (i) Set power off and UNPLUG THE MAINS LEAD AT THE REAR OF THE 9914.
- (ii) Lift the front moulding, until the deck casting is raised to it's fullest extent (almost vertical), ensure that the safety catch on the gas strut is engaged.

- (iii) Disconnect the cables on the operator panel pcb:
 - the N-way membrane panel;
 - the 4-way door solenoid connector;
 - the 2 spade connectors to the door micro-switch;
 - the 2 spade connectors to the lid micro-switch.
- (iv) Disconnect the 50-way cable at P6 on the Servo Control board, free the cable from its securing clips back to the operator panel.
- (v) Remove the 2 nuts which secure the operator panel to the front moulding; note that one bolt is part of the membrane panel.
- (vi) Carefully remove the operator panel. Note: the control buttons remain in place, since they form part of the membrane panel; remove a nut on the left of the front moulding to free the membrane panel.

When replacing the operator panel, reverse the above removal procedure, noting that careful alignment of the legend and the pcb is required. Then check the operation of the panel.

4.6 SUPPLY HUB

4.6.1 Function

The supply hub incorporates three raised lobes which, with a reciprocating action at the start of the load sequence, centralise the tape reel prior to clamping. The hub body contains the mechanism to achieve that clamping when the hub lock arm is driven into contact with the striker plate by the reel clamp solenoid.

4.6.2 Location

The supply hub is clamped onto the SU motor shaft, its domed 11.5 cm diameter top face is visible in the centre of the supply chamber.

4.6.3 Checkout

(a) Mechanical action

This procedure assumes correct action of the reel clamp solenoid.

- (i) Remove the tape reel,
 - raise the tape path cover,
 - run diagnostic program 95,
 - run diagnostic program 45.
- (ii) Check that when 'tens' is pressed the hub solenoid is energised, this is evident from an audible click, and the manual release tongue moving downwards.
- (iii) Hold 'tens' and slowly rotate the hub clockwise, the clamp arms should move smoothly outwards (without tight spots) until over-centre. Release 'tens' (the hub lock arm should drop), rotate the hub anti-clockwise and check that the clamps remain at maximum radius. Press 'tens' (the hub lock arm should engage with the striker plate), rotate the hub anti-clockwise and check that the clamps retract smoothly to the hub crown. Release 'tens' and check that the hub lock arm falls (audible click), the hub should now rotate freely.

(b) Hub Height

Note: this procedure is only valid when an undistorted reel is used.

- (i) Load a large undistorted reel of scratch tape and run diagnostic program 55 to confirm that the tape runs smoothly over the first guide roller.
- (ii) Wind the tape forward using diagnostic program 63, checking that the reel is not clamped askew (if the reel is askew, unload it and re-load), then rewind. Remove the reel and check for good tape packing; ideally this means equal spaces between the tape and each flange but in practice if a piece of paper can be slipped between tape and flange on both sides then this is acceptable.

4.6.4 Setting

There are no settings within the hub mechanism, if the tape reel is slipping then the clamp pads may be dirty due to the cleaning procedure being overlooked, see the 9914 User/Diagnostic Manual.

The height of the spool ledge (ie the reel contact face) in relation the tape path is adjustable as described in the following paragraphs.

(a) Using the height setting tool.

This procedure uses the special supply hub height setting tool, T 6009, which compensates for variations in the height of the motor shaft after assembly. It comprises two parts (body and spacer) as illustrated in Figure 4.6.4.1

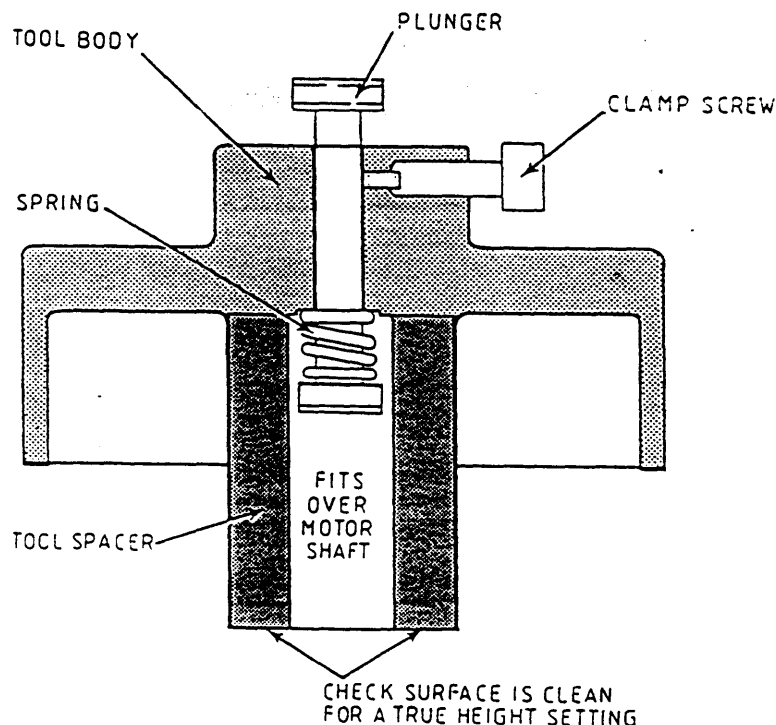

FIGURE 4.6.4.1 SUPPLY HUB HEIGHT SETTING TOOL T6009

- (i) Remove tape reel, set power off and raise the tape path cover.
- (ii) Align the dot on the sloping outer edge of the hub with the slot on the front edge of the streamer casting, insert the long 3/32 AF Allen Key, slacken the clamp screw (see Figure 4.6.5.1) and lift the hub off. If the hub does not readily lift off then see Section 4.6.5, which describes the universal hub removal tool.

- (iii) Check that there is no debris on the motor insulating washer or the spacer part of tool T 6009 (otherwise the correct hub height will not be obtained). Place the spacer around the motor shaft and resting on top of the motor washer.
- (iv) Unlock the clamp screw on the body part of tool T 6009 to free the plunger (see Figure 4.6.4.1).

Place the tool body centrally over the spacer.

Press the tool body down firmly on the spacer so that the plunger rises, hold in position while tightening the clamp screw to set the plunger.

CAUTION: ENSURE THAT THE PLUNGER CLAMP SCREW IS NOT RESET UNTIL THE HEIGHT SETTING PROCEDURE IS COMPLETE.

Lift the tool body away from the motor.

- (v) Rotate the toggle rotor (see figure below) on the supply hub anti-clockwise (viewed from the hub underside) to retract the clamp arms.

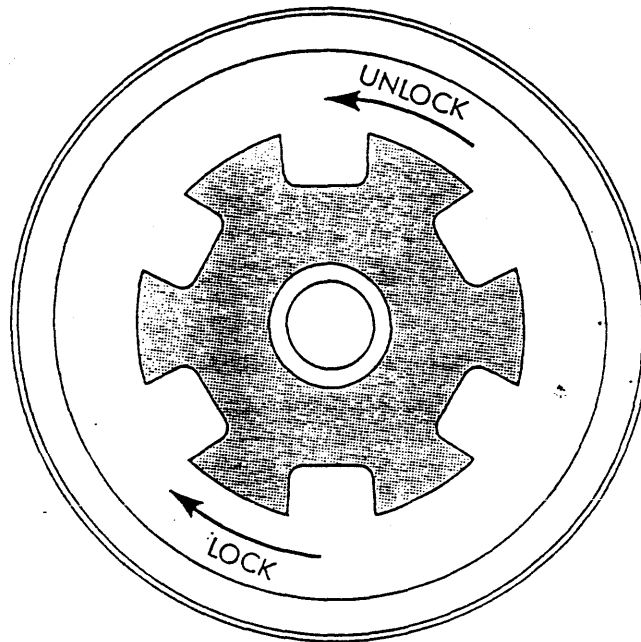

FIGURE 4.6.4.2 SUPPLY HUB TOGGLE (FROM UNDERSIDE)

- (vi) Load the supply hub into the body of the tool (see Figure 4.6.4.3). Check that the hub is fully located all around the edge of the tool to ensure a true height setting.
- (vii) Rotate the toggle rotor clockwise until the mechanism goes over-centre, locking the tool body onto the hub.
Check all around the tool body and supply hub to make certain that they are still in firm contact with each other.
- (viii) Place the tool and hub above the motor shaft. Align the spot on the hub to be nearest the front face of the streamer (see Figure 4.6.4.3).

- (ix) Lower the tool and hub onto the motor drive shaft so that they just engage. Insert the long Allen Key through the slot in the deck and fit it into the socket head cap screw on the hub clamp (see Figure 4.6.5.1).

CAUTION: ENSURE CAREFUL HANDLING OF THE TOOL DURING THE NEXT PROCEDURE. THE PLUNGER SETTING AND HENCE THE HUB HEIGHT SETTING MAY BECOME DISTURBED.

- (x) Gently lower the tool body and supply hub, keeping the Allen Key engaged, until the tool plunger rests on top of the motor shaft.
- (xi) Tighten the hub clamp with the Allen Key, to 12 lb-in torque.

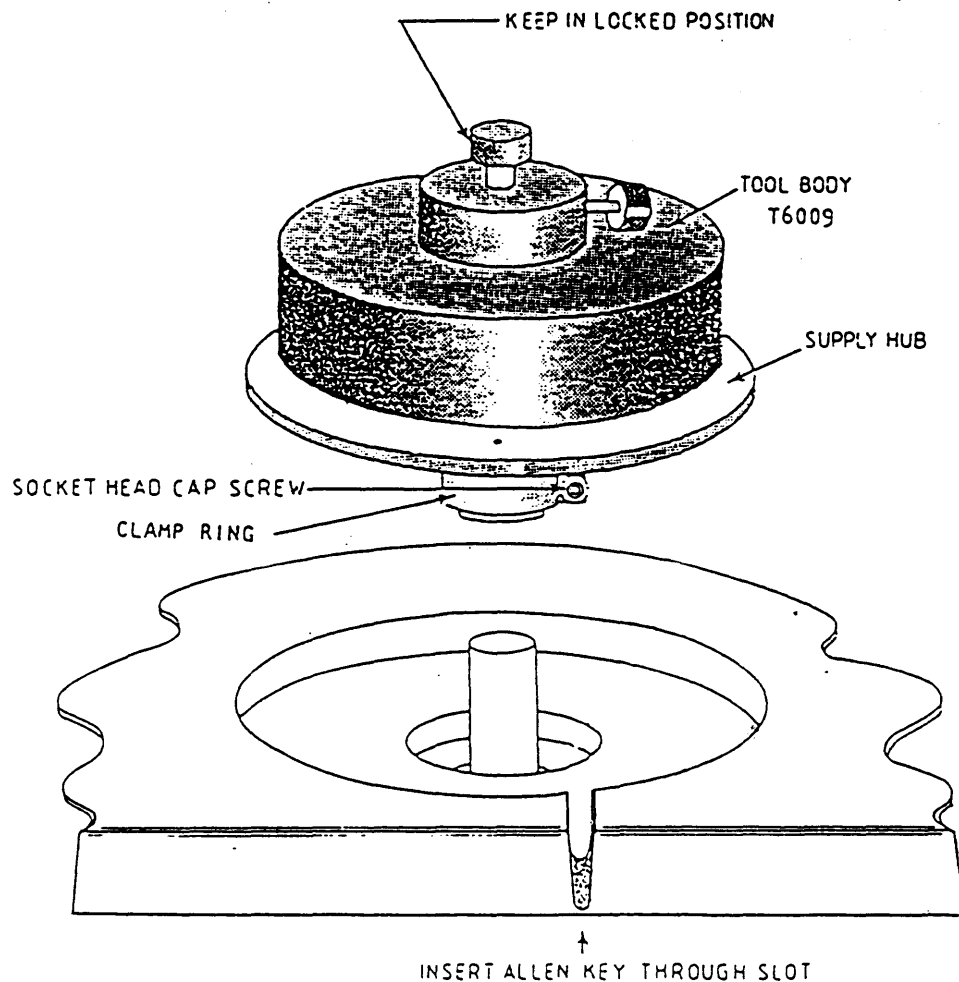

FIGURE 4.6.4.3 FITTING THE SUPPLY HUB

- (xi) To remove the tool body, depress reel clamp solenoid release lever (via an access hole in the top of the deck casting, near the supply chamber). Rotate the tool and hub anti-clockwise until the reel clamp arms have retracted. Lift the tool body up and away from the supply hub.

The height of the supply hub should now be set at 24.51 ± 0.1 mm (spool ledge to top face of motor).

(b) By trial and error

- (i) First use the procedure of Section 4.6.3 (b) to confirm that setting is necessary.
- (ii) Unload and remove the reel of tape, set power off and raise the tape path cover.
- (iii) Place an *undistorted* empty 10 inch reel on the hub.
- (iv) Examine the position of the reel flanges with respect to the first guide roller, to determine the direction and magnitude of the height correction (rotate the reel).
- (v) Align the dot on the sloping outer edge of the hub to be nearest the front edge of the streamer casting.
Insert a long 3/32 AF Allen Key through the slot in the casting (as illustrated in Figure 4.6.5.1), slacken the clamp screw and reposition the hub.
- (vi) Repeat these steps until the alignment appears to be correct.
Tighten the clamp screw, to 12 lb-in torque.

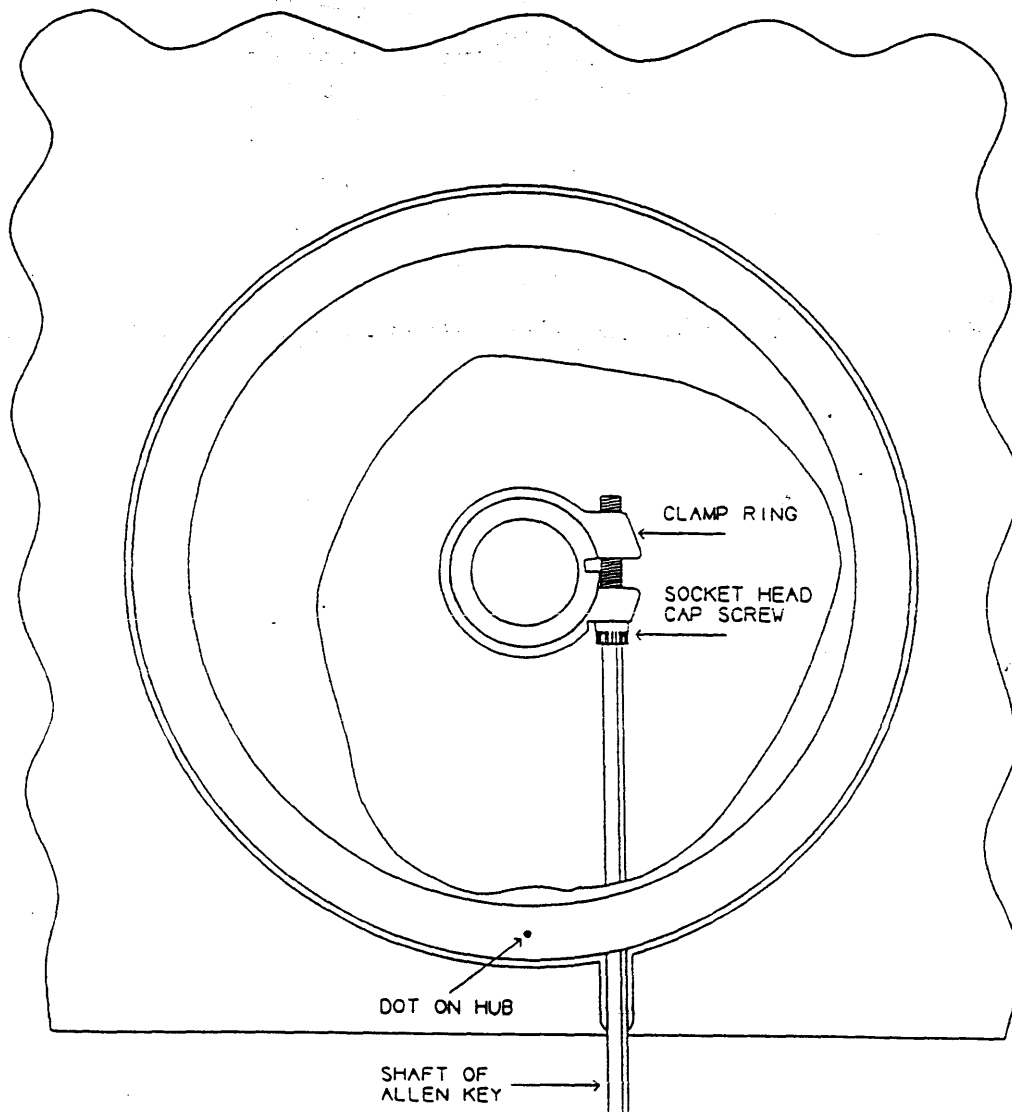

FIGURE 4.6.5.1 LOCATION OF SUPPLY HUB CLAMP

4.6.5 Removal and Replacement

The supply hub assembly is clamped onto the supply motor shaft by means of a ring clamp, access to this using a long Allen key is illustrated in Figure 4.6.5.1.

- (i) Remove tape reel, set power off and raise the tape path cover.
- (ii) Align the dot on the sloping outer edge of the hub with the slot on the front edge of the streamer casting, insert the long 3/32 AF Allen Key, slacken the clamp screw (see Figure 4.6.5.1) and lift the hub off.

If the hub does not readily lift off, the universal hub removal tool T 6037 should be used, as illustrated in Figure 4.6.5.2.

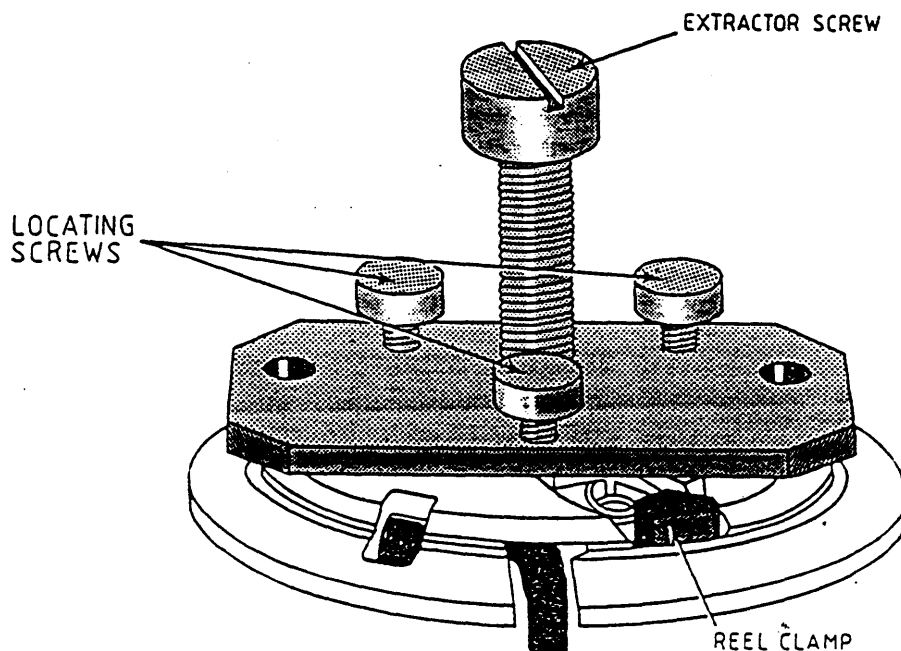

FIGURE 4.6.5.2 UNIVERSAL HUB REMOVAL TOOL (SET FOR SUPPLY HUB)

Check that the tool is configured for supply hub removal (see Figure 4.6.5.2)

- (i) Adjust the large extractor screw fully anti-clockwise and the three pulling screws fully clockwise.
- (ii) Place the tool gently on top of the supply hub so that the three pulling screws drop into the three reel clamp guides.
- (iii) Rotate the tool clockwise until the pulling screws are pressed firmly against the reel clamp guides. Adjust the screws anti-clockwise until they hold the tool firmly in position
- (iv) Rotate the large extractor screw clockwise onto the motor shaft until the supply hub is lifted free of the shaft.

The replacement procedure is identical to the final stages of the height setting procedure, described in the later paragraphs of Section 4.6.4.

4.7 REEL MOTORS

4.7.1 Function

The reel motors are fixed directly to the deck casting and carry the SU and TU hubs, set to the correct height, on their shafts. Current is supplied to the motors to control the direction and torque required to transport tape or hold it steady in 'stop lock' mode.

4.7.2 Location

The reel motors are prominent cylindrical components below the deck casting, being about 100 mm diameter by 150 mm long.

4.7.3 Checkout

There is no routine checkout of the reel motors, running diagnostic program 04 (auto servo checkout) successfully is an indication of acceptable performance. There is no facility to inspect the brushes on the Ametek motors.

4.7.4 Setting

There is no mechanical setting for the reel motors, any error in hub height is corrected by the procedures of Section 4.6.

4.7.5 Removal and Replacement

Set power off and UNPLUG THE MAINS LEAD AT THE REAR OF THE 9914 before commencing any motor removal or replacement.

In order to remove either motor its lead must be unplugged from the Servo Control board and the appropriate hub must be removed from the motor shaft. After replacing a motor, the hub height must be reset.

When replacing a motor with a flat on the shaft, ensure the orientation of the shaft conforms to Figure 4.7.

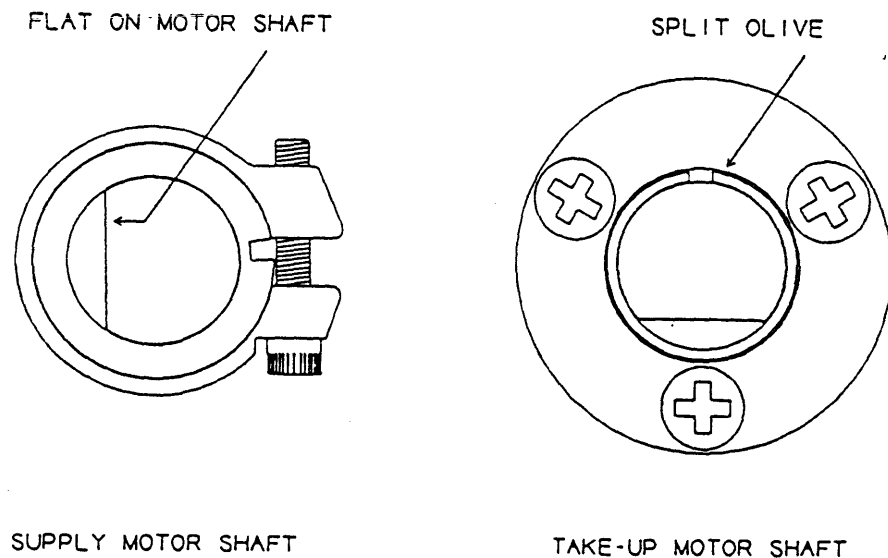

FIGURE 4.7 ORIENTATION OF MOTOR SHAFT

4.8 TAPE PATH ASSEMBLY

4.8.1 Function

The tape path casting is the reference component of the tape path, it locates against the reference face on the underside of the deck casting to carry:

- . the read/write and erase head block;
- . the tape cleaner;
- . the two bollards
- . the BOT/EOT sensors board;
- . the 'in-chute' Tx/Rx blocks;
- . the pre-amplifier assembly;
- . the tension arm assembly;
- . the tachometer assembly.

The height of these items with respect to the tape is controlled to give an accurate tape path with no height adjustments.

4.8.2 Location

The tape path assembly is an aluminium casting, located as illustrated in Chapter 5, against the reference faces on the underside of the deck casting.

4.8.3 Checkout

Only severe mechanical damage can be expected to alter the orientation of the tape path with respect to the three tape path mating faces.

The azimuth screw is set at the factory, to give the required skew performance. Diagnostic programs 82 and 83 have been allocated to verify the skew performance.

4.8.4 Setting

The tape path mechanics are not field adjustable.

The BOT and EOT sensors can be set up as follows.

- (i) Select a reel of tape which has a highly reflective base (back-coated or dull-coated tapes are not suitable);
- (ii) with power on, load a tape by hand until the BOT marker is near the BOT/EOT block;
- (iii) raise the front moulding to its fullest extent (to near vertical), ensure that the safety catch on the gas strut is engaged;
- (iv) monitor IC34 pin 13 on the Servo Control board with a dc voltmeter;
- (v) hold the reels so that the tension arm is centrally positioned and the BOT marker not opposite its detector;
- (vi) Check that the output is within the range 3.4 to 4.6 volts, adjusting R2 if necessary;
- (vii) move the tape so the marker is opposite the detector block, check that the output is now less than 300 mV;
- (viii) attach an EOT marker a few inches before the BOT marker;
- (ix) repeat (iii) to (vii) for the EOT circuit, monitoring IC34 pin 11 and adjusting R1 if necessary;
- (x) remove the EOT marker;
- (xi) remove the voltmeter, lower the deck casting, and load a tape to BOT to confirm correct operation.

4.8.5 Removal and Replacement

Note: the Tape Path assembly contains electronic circuit boards, and is ESD sensitive, see Section 4.1.2 for handling precautions.

Set power off and **UNPLUG THE MAINS LEAD AT THE REAR OF THE 9914** before commencing tape path removal or replacement.

Lift the front moulding, until the deck casting is raised to its fullest extent (almost vertical), ensure that the safety catch on the gas strut is engaged.

Before removing the tape path assembly, release the attached cables:

- (i) the 40-way cable to the Servo Control board;
- (ii) the 40-way cable to the ADP board;
- (iii) the 28-way cable to the ADP board;
- (iv) the 14-way cable to the hub sensor pcb.

Attach some temporary covering (such as that supplied by the head manufacturer) to the recording surface of the head, for additional protection while removal is in progress. Suitable covering could be a piece of lint-free cloth secured in place by adhesive tape.

The tape path is fixed to the deck casting by three screws, one at each end and one at mid-point, near the 9914's outer edge. While extracting the tape path assembly, stand on the right of the machine and be extremely careful not to scrape the head face against the adjacent casting.

Replacement is essentially the reverse of removal; again being extremely careful not to scrape the head face against the adjacent casting, and equally careful not to impact the rollers.

4.9 TAPE CLEANER

4.9.1 Function

The tape cleaner presents a very sharp edge to the tape at an acute angle during forward tape motion, any surface debris is thereby removed from the tape before it reaches the head.

4.9.2 Location

The tape cleaner is mounted on the head plate, near the head block, as illustrated in Chapter 5.

4.9.3 Checkout

WARNING: ONE EDGE OF THE SAPPHIRE CLEANER IS EXTREMELY SHARP; OBSERVE GREAT CARE.

The tape cleaner may be checked by visual examination, the edges should be straight and free from chips if damage to the tape is to be avoided. Observation with the tape loaded will show a small tape deflection of the tape by protrusion of the cleaner blade into the line of the tape.

The tape cleaner's angle of attack and intrusion into the tape path are fixed by two locating pins.

4.9.4 Setting

No re-setting is required.

4.9.5 Removal and Replacement

WARNING: ONE EDGE OF THE SAPPHIRE CLEANER IS EXTREMELY SHARP. HANDLE WITH GREAT CARE.

Set power off and **UNPLUG THE MAINS LEAD AT THE REAR OF THE 9914** before commencing any tape cleaner removal or replacement.

The tape cleaner is removable by undoing its fixing screw under the head plate; take care not to undo screws belonging to other tape path components.

4.10 TAPE PATH ROLLERS

4.10.1 Function

The tape path rollers assist in transporting and guiding the tape along the tape path, they are precision made rotating parts.

4.10.2 Location

Three flanged rollers are used on the 9914, one near the exit from the supply chamber, one mounted on the outer end of the tension arm and one at the entrance to the take-up chamber. The front and rear rollers are identical.

4.10.3 Checkout

Ensure that the rollers run freely and smoothly on their bearings, show no excessive end float, have no flange damage or roughness, and have clean smooth contact surfaces. If a bearing does not run smoothly this is usually apparent when it is rotated slowly by hand (compare with another); when rotated fast a rough bearing will cease to rotate immediately.

The height of each roller is manufactured to make a straight tape path. Load a tape which is free of edge damage and examine the tape contact with the roller flanges while running diagnostic program 55, light edge contact is normal but curling against a flange causes tape damage.

4.10.4 Setting

There is no setting procedure, if a roller is replaced with its own shim the straight tape path is retained.

4.10.5 Removal and Replacement

Set power off and **UNPLUG THE MAINS LEAD AT THE REAR OF THE 9914** before commencing any roller removal or replacement.

Removal and replacement of the rollers in the SU and TU chambers is straightforward except that any shims supplied with the replacement roller must be retained as part of the replacement roller assembly.

The roller at the outer end of the tension arm appears to be an integral part of the tension arm assembly but may be replaced by moving the tension arm away from its rest position and using a bent tommy bar to engage with the hole in the roller base.

4.11 TENSION ARM ASSEMBLY

4.11.1 Function

The tension arm assembly incorporates the arm itself together with a damping device and the position sensing circuits, including the 'limit' flags and optical switch.

4.11.2 Location

The tension arm itself is visible above the deck casting; the damping mechanism and position sensor circuits are below the deck casting.

4.11.3 Checkout

(a) Display check for arm position and limit

This procedure checks that the limit flag and position data is correctly interpreted by the Servo Control processor. It is important that the position sensor emits zero output at centre travel and that the limits are approximately equal.

- (i) Run diagnostic program 47, the 'LIMIT' quantity in the indication may be ignored until step (ii). The other three characters indicate the position sensor output; with the arm at rest they should indicate about 80, at full travel they should indicate about 180. These are not rigid limits outside which re-setting must be carried out, but may be regarded as an indication of correct operation, the absolute limits are set out in (b) below.
- (ii) Check that when the arm is at either limit of travel, the indicated leading characters in the display are 'LIMIT', and as the arm is moved away from either 'limit' the 'LIMIT' disappears!

(b) Voltage check for arm position and limit

- (i) Unload the tape and set power off; raise the deck casting to monitor the test points, as stated (ensure that the safety catch on the gas strut is engaged).
- (ii) On the tension arm board, monitor IC1.7. Set power on and check that the position sensor generates approx +1.0 V (± 0.2 V) relaxed, zero at mid-position and -1.0 V (± 0.2 V) at full tension; the most important feature is zero volts at mid-travel. This level appears on the Servo Control board at the R64/C40 junction. Mid-travel is when the tension arm is pushed just clear of the small hole in the casting.
- (iii) On the Servo Control board, monitor IC34 pin 3 (or pin 4 - the gate output). Move the tension arm and check that it goes low (limit detected) just before the mechanical limit of travel, in both directions.

(c) Diagnostic test for arm response

Run diagnostic program 48 (tension arm response), as described in Section 3.4.

4.11.4 Setting

The most important parameter of the position sensor is that at mid-travel its output is zero, this parameter is set during manufacture and does not vary during use. Should a circuit component be replaced, the following notes are provided.

Monitor IC1.7 to examine the output voltage. The offset control R8 is provided to set the output to 0.0 V when the tension arm is at mid-travel. The gain control R9 is provided to set the output to ± 1.0 (± 0.2) V at the travel extremes.

4.11.5 Removal and Replacement

The tension arm roller removal/replacement is described in Section 4.10. The electronic components are not field-replaceable, because the position sensor is set up at the factory as part of the tape path assembly.

4.12 DATA CONTROL BOARD

4.12.1 Function

The Data Control board supervises the data-related parts of all logic activity, it is described in Chapter 2.

4.12.2 Location

The Control board is a plug-in printed circuit board which fits into the third slot in the card rack, as illustrated in Chapter 5, using three dual 32-way connectors.

4.12.3 Checkout

Specific Data Control board faults are highlighted by messages on the 8-character display at the front of the 9914, Section 3.3 sets out these messages.

A general checkout of the Data Control board involves running one or more of diagnostic programs 05 to 09, depending on the fault symptom(s). This procedure assumes that the operator panel and Servo Control board are both fully functional.

4.12.4 Setting

The Data Control board does not incorporate any potentiometers, parameter-setting links, or switch options.

The link near the lower right corner determines whether the line termination resistors are powered from within the 9914 (as is usual) or from outside (as with daisy-chain systems).

The links LK1 and LK2 (near upper edge of the board) should always be fitted when the board is in service.

The battery (which maintains the NVR contents when power is switched off) has a nominal life of 7 years, and a worst-case life of 5 years. It should be noted that if the **NVR message appears and LD/ONL is pressed to re-load the NVR, the parameters loaded are default values, the operational values must be determined by re-calibration.

4.12.5 Removal and Replacement

Note 1: the Data Control board is ESD sensitive, see Section 4.1.2 for handling precautions.

Note 2: the Data Control and DDP boards are paired. Earlier p/n 121600 goes with 121700, while later p/n 123638 goes with 123620. All drives will have been shipped with compatible pairs; the pairs should not be mixed.

- (a) Set power off and unplug the mains lead at the rear of the streamer;
- (b) identify the Data Control board;
- (c) disconnect any connectors which prevent the Data Control board being withdrawn;
- (d) raise the two board extractors, simultaneously;
- (e) lift the board straight out.

If replacing the battery, ensure it is fitted with the positive side uppermost (the '+' contact is marked on the pcb). If installing a new Data Control board, remove the insulating strip which is inserted under the positive battery contact.

When replacing the board, ensure it is placed in the third slot and the edge connectors are correctly aligned with the Mother board sockets before pushing the board fully home. No attempt should be made to insert the Data Control board in any but the third slot, because the all pcb's have designated positions, determined by the edge connectors.

- (i) Set power on and allow the power-on diagnostics to run, the ****NVR** message may appear, if so press LD/ONL to by-pass this indication; the ****DN1** message may appear next, if so press LD/ONL to by-pass this indication. If the 9914 loading door is open, 'Ready' should be displayed, if the 9914 loading door is closed, LOCATING should be displayed, press RESET once to halt the loading attempt and once again to open the door.
- (ii) Run program 95 and enter the service key.
Run program 80.
- (iii) Power cycle the 9914.
Load a standard amplitude tape to BOT.
Leave the 9914 powered on for 15 minutes, to allow the small signal circuits to stabilise.
- (iv) Run program 95 and enter the service key.
Run diagnostic program 74 to re-calibrate the 9914.
- (v) Set power off, wait a few seconds and set power on again. Allow the power-on diagnostics to run, there should be no error message.
- (vi) Load a scratch tape to BOT.
Run diagnostic program 01.

4.13 ANALOGUE DATA PATHS BOARD

4.13.1 Function

The Analogue Data Paths (ADP) board handles the analogue tape data, it is described in Chapter 2.

4.13.2 Location

The Analogue Data Paths board is a plug-in printed circuit board which fits in the first (ie the front) slot in the card rack, using two dual 32-way connectors.

4.13.3 Checkout

A checkout of the ADP board involves running diagnostic program 07; this procedure assumes that other boards are fully functional.

4.13.4 Setting

The ADP board has no potentiometers, links, or switches. Any parameter setting is achieved electronically by signals from the Data Control board.

4.13.5 Removal and Replacement

Note: the ADP board is ESD sensitive, see Section 4.1.2 for handling precautions.

- (a) Set power off and unplug the mains lead at the rear of the streamer;
- (b) identify the ADP board;
- (c) disconnect the IDC connectors to the pre-amplifier and Servo Control boards;
- (d) raise the two board extractors, simultaneously;
- (e) lift the board straight out.

When replacing the board, reverse the removal procedure, ensuring that the ADP board is inserted in the first slot and the edge connectors are correctly aligned with the Mother board sockets before pushing the board fully home.

No attempt should be made to insert the ADP board in any but the first slot, because its position is mechanically determined by its connectors.

After ADP board replacement, the 9914 must be re-calibrated using diagnostic program 74 before being returned to on-line use.

4.14 DIGITAL DATA PATHS BOARD

4.14.1 Function

The Digital Data Paths (DDP) board decodes the Pertec interface commands and executes the digital data processing associated with all recording densities.

A functional description appears in Chapter 2.

4.14.2 Location

The DDP board is a plug-in printed circuit board which fits into the second slot in the card rack, as illustrated in Chapter 5.

4.14.3 Checkout

A checkout of the DDP board involves running one or more of diagnostic programs 05 to 09; this procedure assumes that other boards are fully functional.

4.14.4 Setting

The DDP board contains the nine potentiometers which are set up at the factory to optimise the capture performance of the phase lock loop for each data channel. The re-setting of these pots is not required, if the PLL chips are replaced, re-setting of the pots requires base-station type facilities.

4.14.5 Removal and Replacement

Note 1: the DDP board is ESD sensitive, see Section 4.1.2 for handling precautions.

Note 2: the DDP and Data Control boards are paired. Earlier p/n 121700 goes with 121600, while later p/n 123620 goes with 123638. All drives will have been shipped with compatible pairs; the pairs should not be mixed.

- (a) Set power off and unplug the mains lead at the rear of the streamer;
- (b) identify the DDP board;
- (c) disconnect any connectors which prevent free withdrawal of the DDP board;
- (d) raise the two board extractors, simultaneously;
- (e) lift the board straight out.

When replacing the board, reverse the removal procedure, ensuring that the edge connectors are correctly aligned with the Mother board socket before pushing the board fully home.

No attempt should be made to insert the DDP board in any but the second slot, because its position is mechanically determined by its connectors.

4.15 SCSI BOARD

4.15.1 Function

The SCSI board handles the SCSI interface commands, it is described in Chapter 2.

4.15.2 Location

The SCSI board is a plug-in printed circuit board which fits in the rearmost slot in the card rack and carries a connector for the SCSI signals to/from the host computer.

4.15.3 Checkout

A checkout of the SCSI board is automatically carried out when power is applied to the 9914. At other times its status can be interrogated by the SCSI 'request status' command.

4.15.4 Setting

The SCSI board contains slide switches and links which are set according to the customers' system, as set out in the SCSI User Manual. Alternatively the 9914's NVR may be configured to hold these options, as described in Section 3 under 'Configurable Options'.

4.15.5 Removal and Replacement

Note: the SCSI board is ESD sensitive, see Section 4.1.2 for handling precautions.

No attempt should be made to remove or replace the interface connector while power is still applied to the 9914.

- (a) Set power off and unplug the mains lead at the rear of the streamer;
- (b) identify the SCSI board;
- (c) disconnect the SCSI interface connector;
- (d) raise the two board extractors, simultaneously;
- (e) lift the board straight out.

CHAPTER 5 - SUB-ASSEMBLY LOCATIONS AND SPARES LISTS

<i>CONTENTS</i>		<i>Page</i>
5.1	SCOPE OF CHAPTER 5	1
5.2	SUB-ASSEMBLY LOCATIONS	1
5.3	AVAILABLE SPARES	8

5.1 SCOPE OF CHAPTER 5

Section 5.2 contains two-dimensional drawings to aid the location of sub-assemblies, Chapter 6 contains more detailed technical illustrations which include the related fixings.

Section 5.3 lists the available spares.

5.2 SUB-ASSEMBLY LOCATIONS

Section 5.2 consists of several figures which enable the location and identification of mechanical and electronic sub-assemblies.

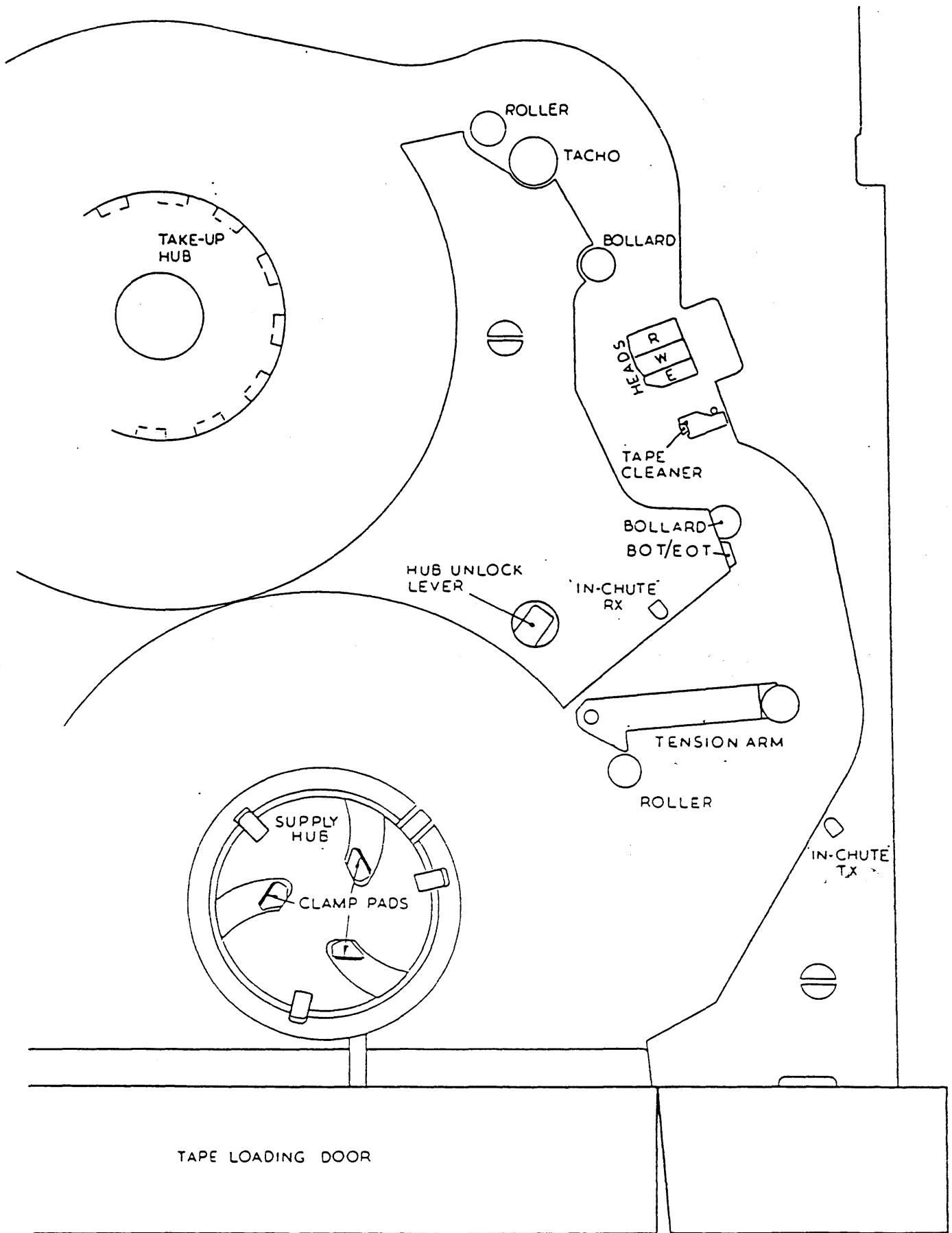

FIGURE 5.2.1 9914 TAPE PATH COMPONENTS

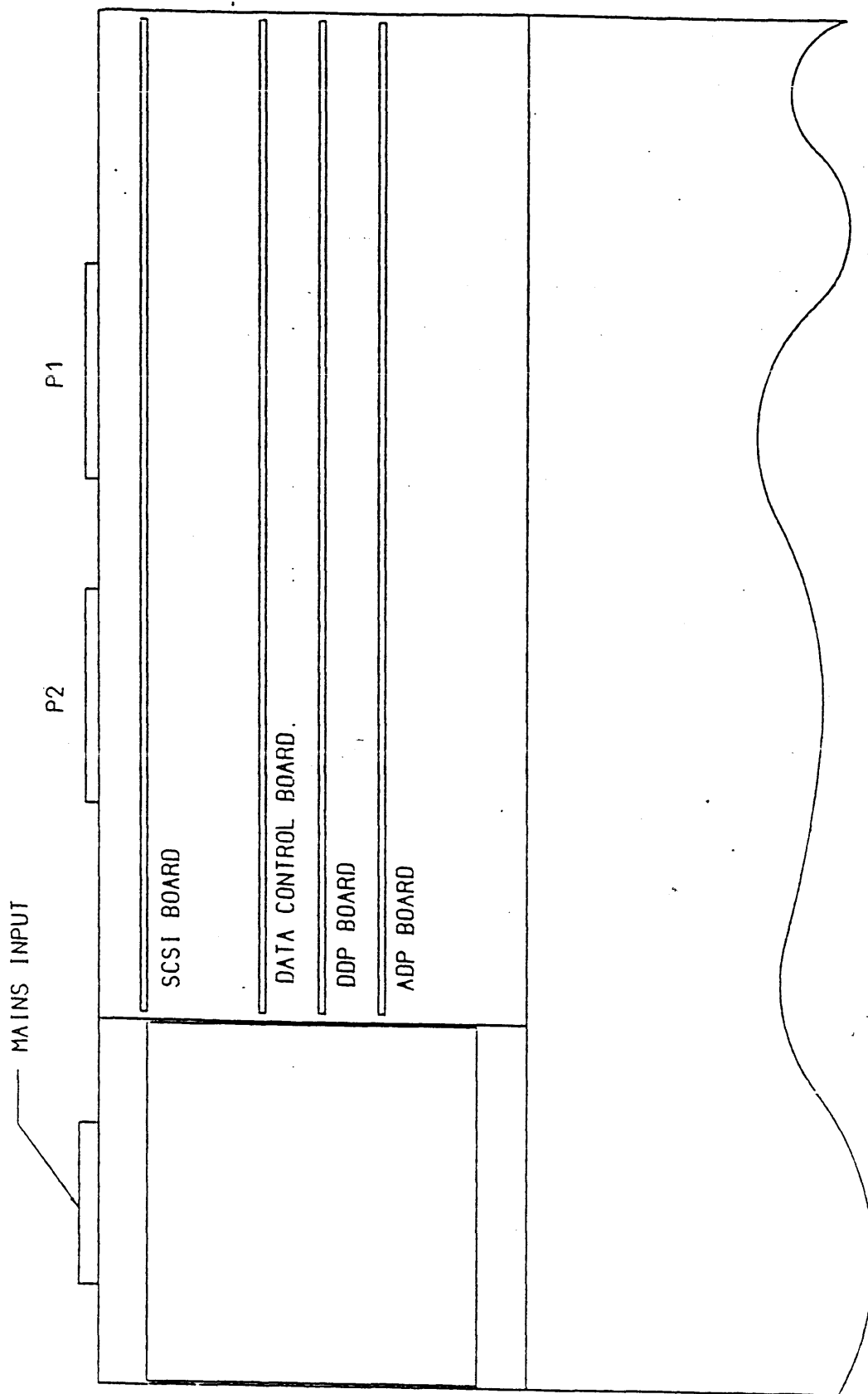

FIGURE 5.2.2 9914 CIRCUIT BOARD POSITIONS

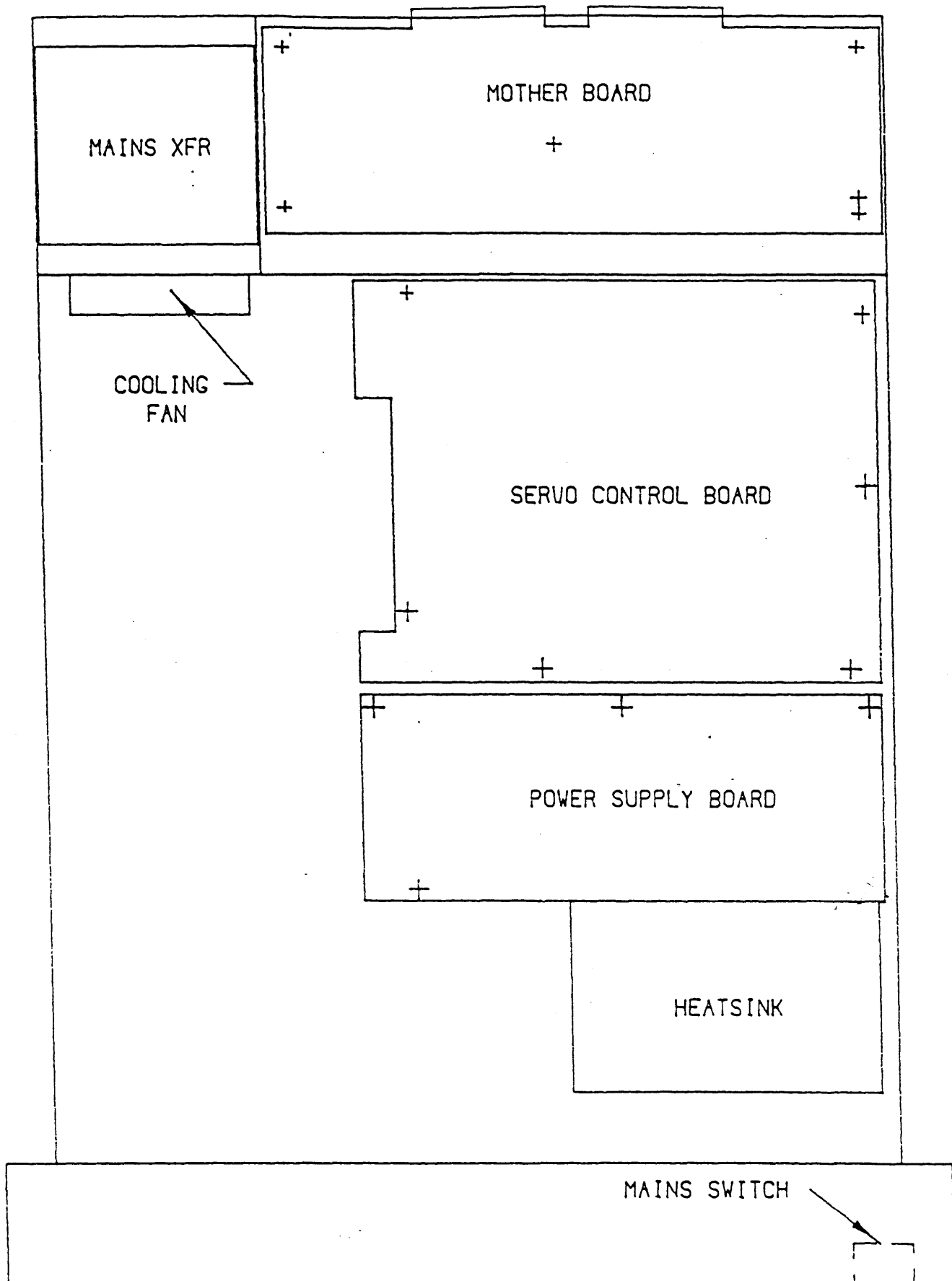

FIGURE 5.2.3 9914 BASE TRAY SUB-ASSEMBLIES

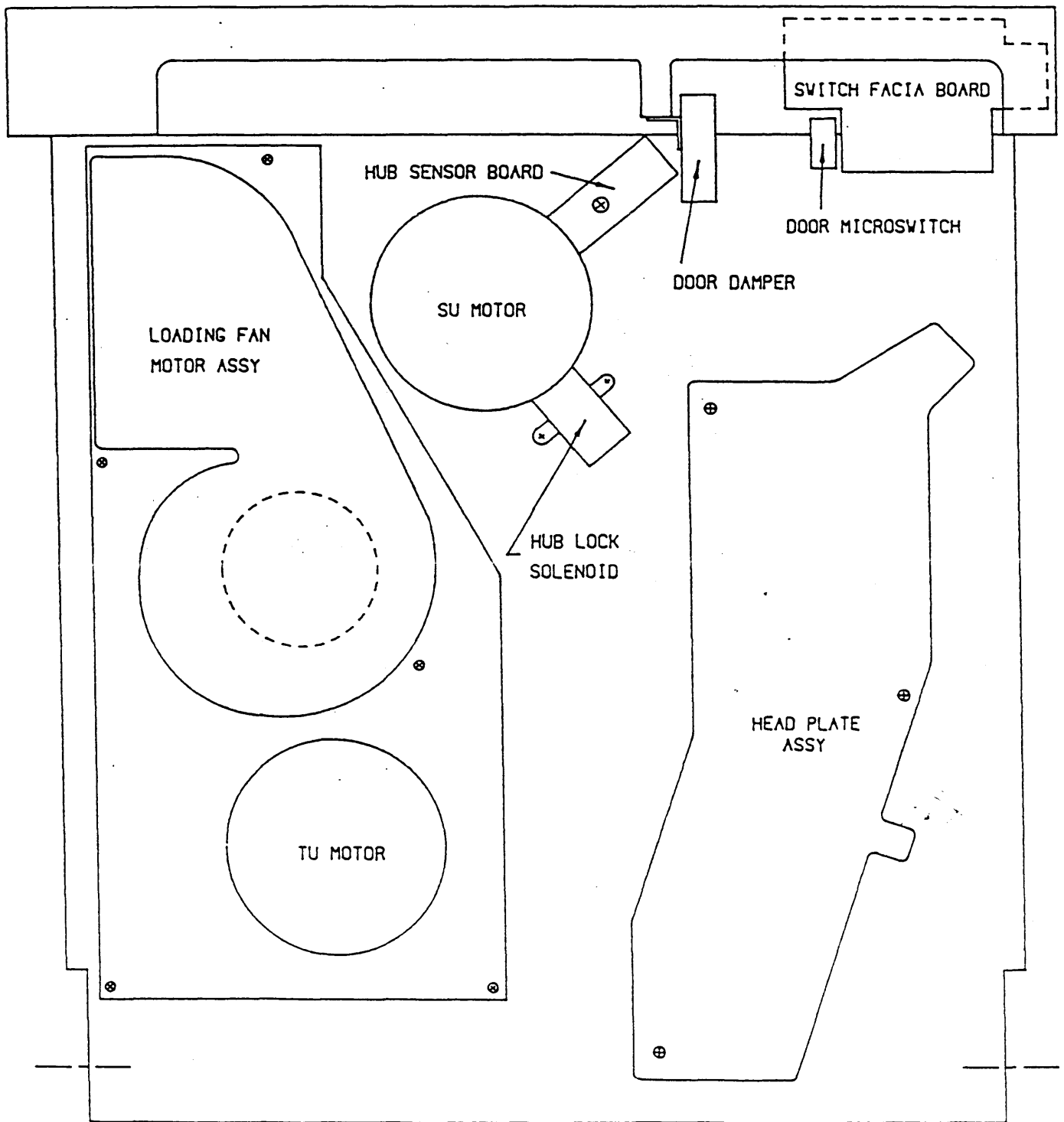

FIGURE 5.2.4 9914 DECK CASTING UNDERSIDE SUB-ASSEMBLIES

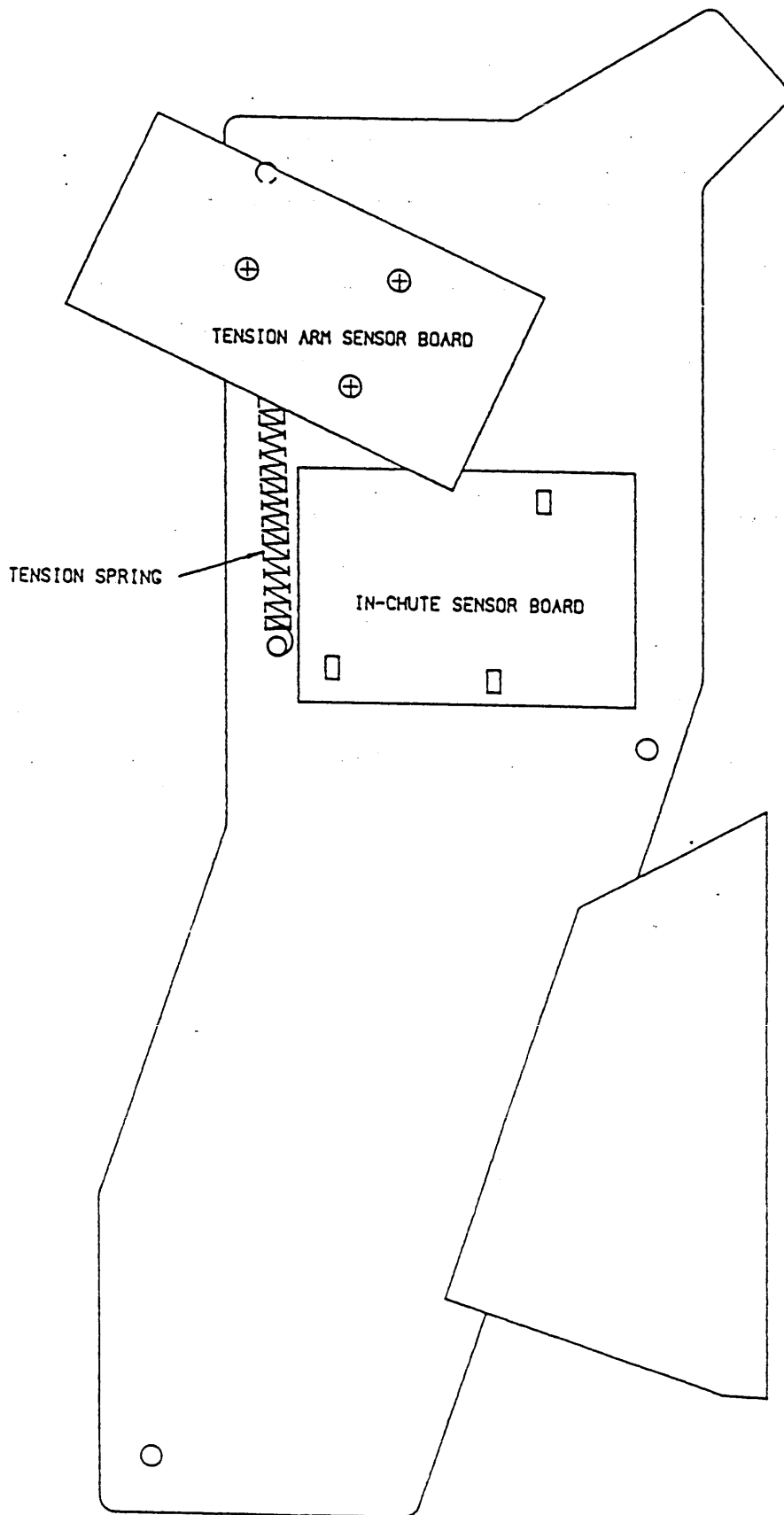

FIGURE 5.2.5 9914 TAPE PATH ASSEMBLY UNDERSIDE

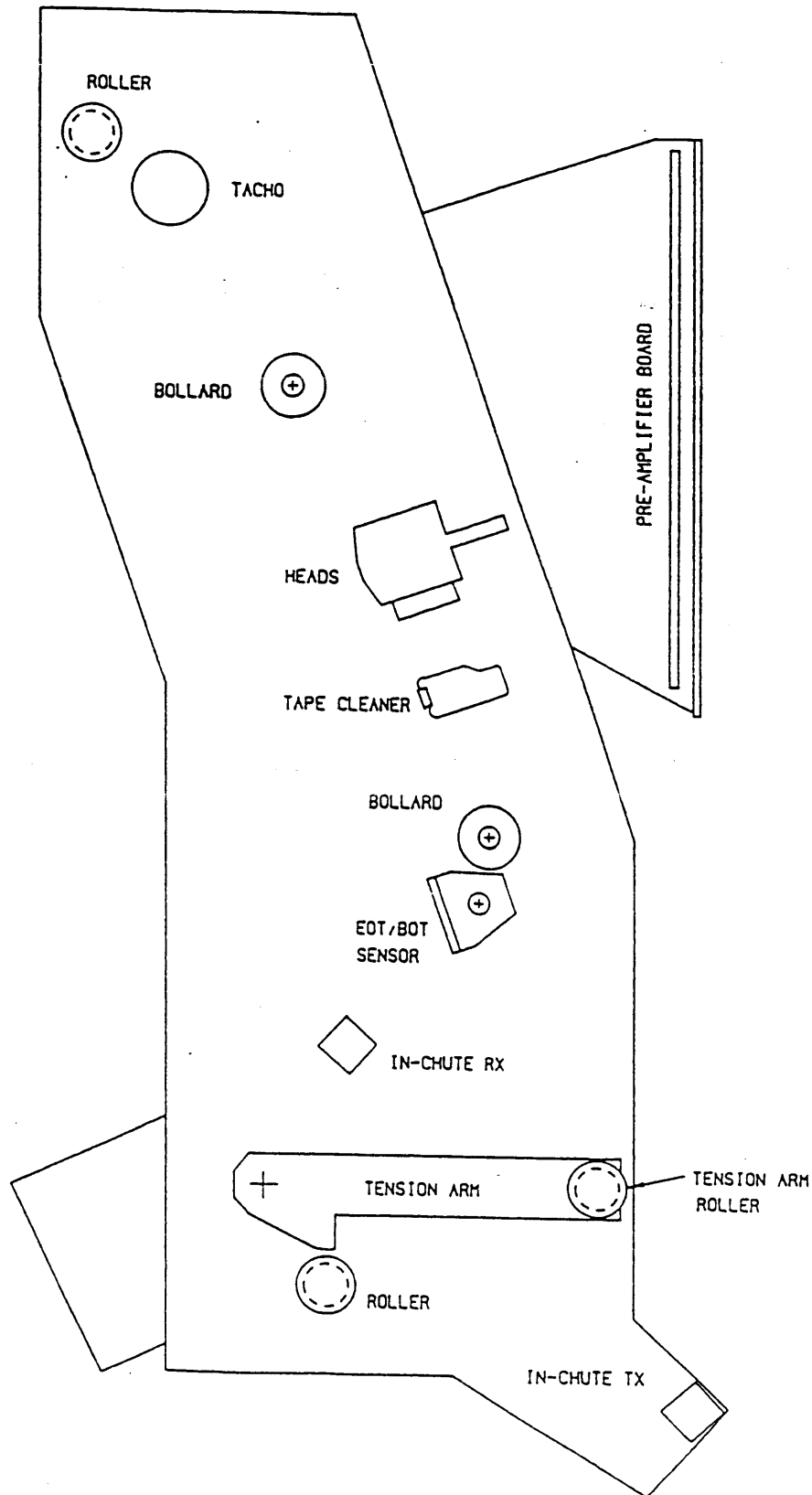

FIGURE 5.2.6 9914 TAPE PATH ASSEMBLY TOP SIDE

<i>CONTENTS</i>		<i>Page</i>
5.3.1	Introduction	8
5.3.2	Major Spares List	8
5.3.3	Subsidiary Spares List	9

5.3.1 Introduction

The available spares list includes items which are recommended spares, applicable to individual sites where the 9914 is in use. The complete available spares list is considered applicable to base stations which service many streamers.

The electronic assembly Parts List (PL) number is given for each individual part as well as the system tested spares number. A system tested spare is a part which has been tested as functional in a system configuration.

5.3.2 Major Spares List

Spare description	Parts list number	System tested spares number
Tape Path Assembly	121736	95 121736 00
Supply Hub Assembly	109767	95 109767 08
Hub Sensor pcb	120920	95 120920 00
Hub Lock Assembly	121722	95 121722 00
Reel Motor Assembly	121721	95 121721 00
Cooling Fan Assembly	121908	95 121908 01
Loading Fan Motor Assembly	121723	95 121723 00
Analogue Data Paths board	121710	95 121710 00
Data Control board (<i>later</i>) (<i>pairs with next item</i>)	123638	95 123638 00
Digital Data Paths board	123620	95 123620 00
Servo Control board	121050	95 121050 00
Power Supply board	121590	95 121590 00
Switch Fascia pcb	121160	95 121160 00
Door Solenoid Assembly	121906	95 121906 00
SCSI board (512K Single-ended)	123510	95 123510 00
SCSI board (512K Differential)	123511	95 123511 00
Pertec Cache Interface board (512K)	123702	95 123702 00
Fuse Kit		95 121851 00
Door micro-switch	QS22821	95 228210 00
Mains Switch	QS24004	95 240040 00
Data Control board (<i>early</i>) (<i>pairs with next item</i>)	121600	95 121600 00
Digital Data Paths board	121700	95 121700 00

5.3.3 Subsidiary Spares List

Spare description	Parts list number	System tested spares number	Notes
Front/Rear Roller	123240	95 123240 00	TPA
Tension Arm Roller	123910	95 123910 00	TPA
Tape Cleaner Assembly	119287	95 119287 00	TPA
In Chute Sensor pcb	120860	95 120860 00	TPA
Tension Arm pcb	121010	95 121010 00	TPA
Head Amplifier pcb	121884	95 121884 00	TPA
EOT/BOT pcb	120910	95 120910 00	TPA
Tension Spring	IS13338	95 133380 00	TPA
Battery (board 121600 only)	IS13327	95 133270 00	DC

Notes:

TPA = part included in Tape Path Assembly.

DC = part included in Data Control board.

CHAPTER 6 - ILLUSTRATED PARTS LISTS

CONTENTS

Page

6.1	SCOPE OF CHAPTER 6	2
6.2	USING THE ILLUSTRATIONS	2
6.2.1	Tape Path Assembly	4
6.2.2	Tape Rollers and Cleaner	6
6.2.3	Supply Hub Assembly	8
6.2.4	Hub Sensor pcb	10
6.2.5	Hub Lock Assembly	12
6.2.6	Supply Reel Motor Assembly	14
6.2.7	Take-up Reel Motor Assembly	16
6.2.8	Cooling Fan Assembly	18
6.2.9	Loading Fan Motor Assembly	20
6.2.10	Power Supply board	22
6.2.11	Servo Control board	24
6.2.12	Data Control board	26
6.2.13	Analogue Data Paths board	28
6.2.14	Digital Data Paths board	30
6.2.15	SCSI (or PCI) board	32
6.2.16	Switch Fascia pcb	34
6.2.17	Door Solenoid Assembly	36
6.2.18	Door micro-switch	38
6.2.19	Mains Switch	40
6.2.20	Tape Path Cover	42

6.1 SCOPE OF CHAPTER 6

The Illustrated Parts Lists provide a rapid visual and part number reference to all field replaceable units (FRU's) - and attaching hardware - which are listed as major spares in Section 5.

6.2 USING THE ILLUSTRATIONS

Each illustration has numbered callouts; each number represents the associated FRU or attaching hardware. The text on the following (facing) page contains:

- . Figure reference number;
01 onwards for the replaceable part,
10 onwards for any attaching hardware.
- . Part number
- . Description
- . Quantity

Abbreviations

The following abbreviations are used, particularly when describing screws.

General format: SCR, Head type, Size, Thread pitch x length, Material and/or plating

SCR	Screw
SCR-LOC	Screw - self-locking type
ASH	Allen Socket Head, also called 'hex wrench'
CSK	Countersunk head
FHS	Flat Head Screw
PAN	Pan-head - ie a domed head
POZ	Pozidriv-style screwdriver recess
THR-FM	Thread Forming Screw (Self Tapping)
UNC	Unified coarse thread
6-32x3/8	Size, thread pitch & length
BO	Black Oxidised
HTST	High Tensile Steel
MS	Mild Steel
ZP	Zinc Plated
HEX	Hexagonal
BC	Beryllium Copper
CRI	Crinkle
FSTNR	Fastener
IT	Internal Teeth
M	Metric size
MTG	Mounting
WAS	Washer
SHP	Shakeproof
SC	Single Coil
UN	Unified (washer), to fit corresponding screw size

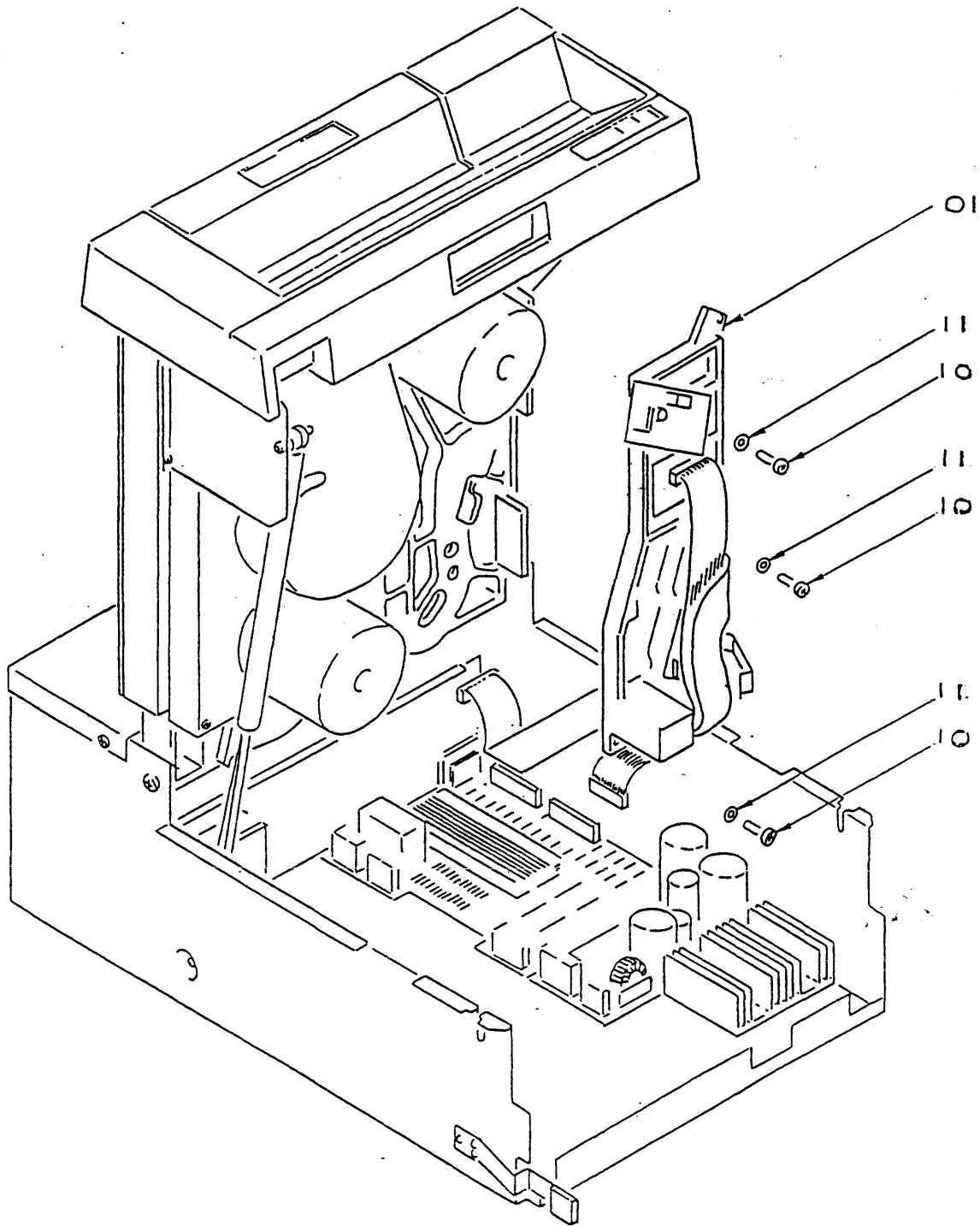

FIGURE 6.2.1 TAPE PATH ASSEMBLY

Figure ref.	Part Number	Description	Qty
01	95 121736 xx	Tape Path Assembly	1

Attaching Hardware:

Figure ref.	Part Number	Description	Qty
10	95 041065 xx	SCR, POZ PAN 8-32UNCx5/8	3
11	95 041596 xx	WAS, 8-32UNC, SHP, IT	3

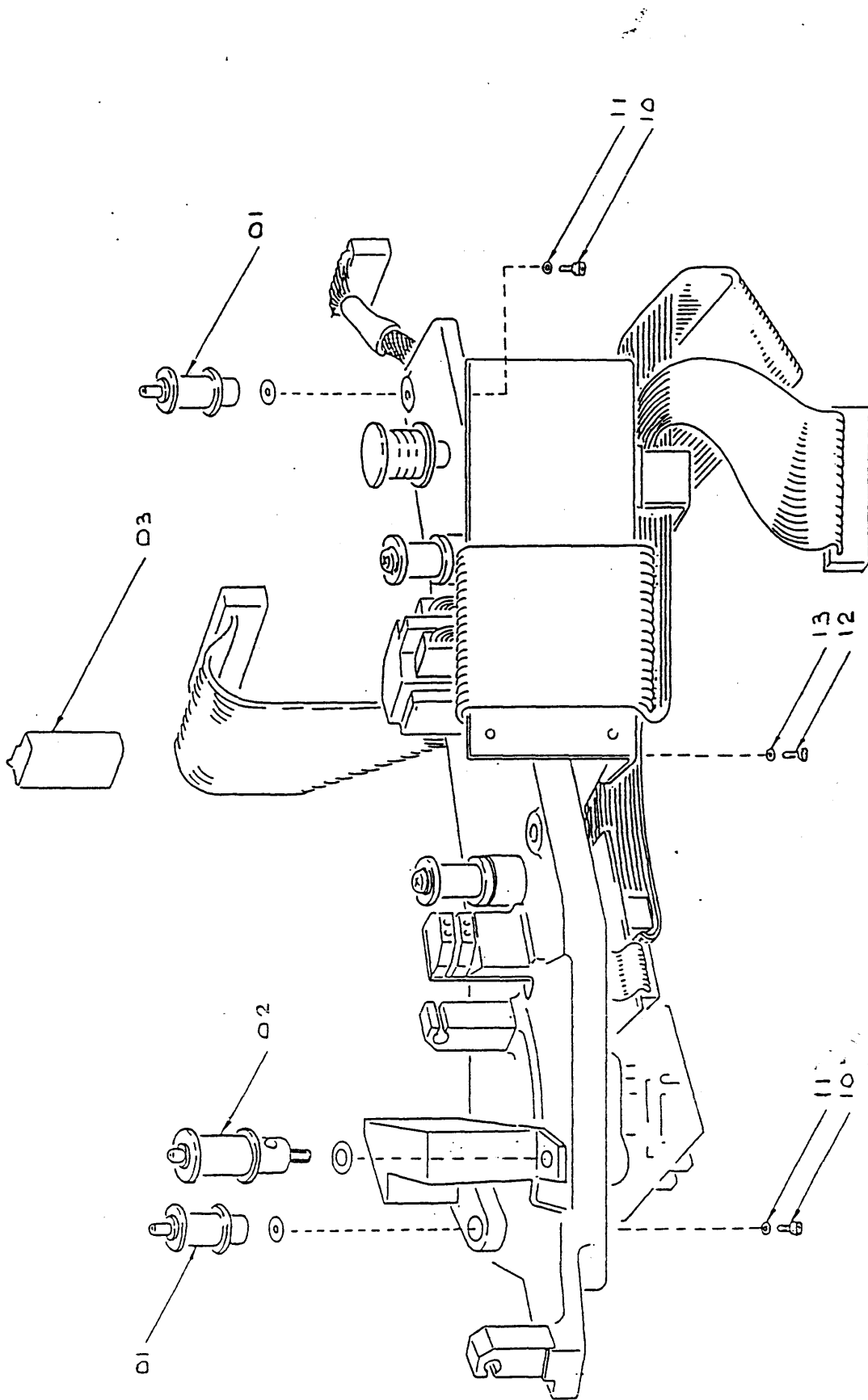

FIGURE 6.2.2 TAPE PATH ROLLERS AND CLEANER

Figure ref.	Part Number	Description	Qty
01	95 123240 xx	Front Roller	1
01	95 123240 xx	Rear Roller	1
02	95 123910 xx	Tension Arm Roller	1
03	95 119287 xx	Tape Cleaner	1

Attaching Hardware:

Figure ref.	Part Number	Description	Qty
10	95 041591 xx	SCR, ASH 6-32x1/2 HTST	2
11	95 041346 xx	WAS, CRI, 6UN, BC ZP	2
12	95 041057 xx	SCR, POS PAN, 6-32UNCx5/8	1
13	95 041662 xx	WAS, SHP, 6UN IT	1

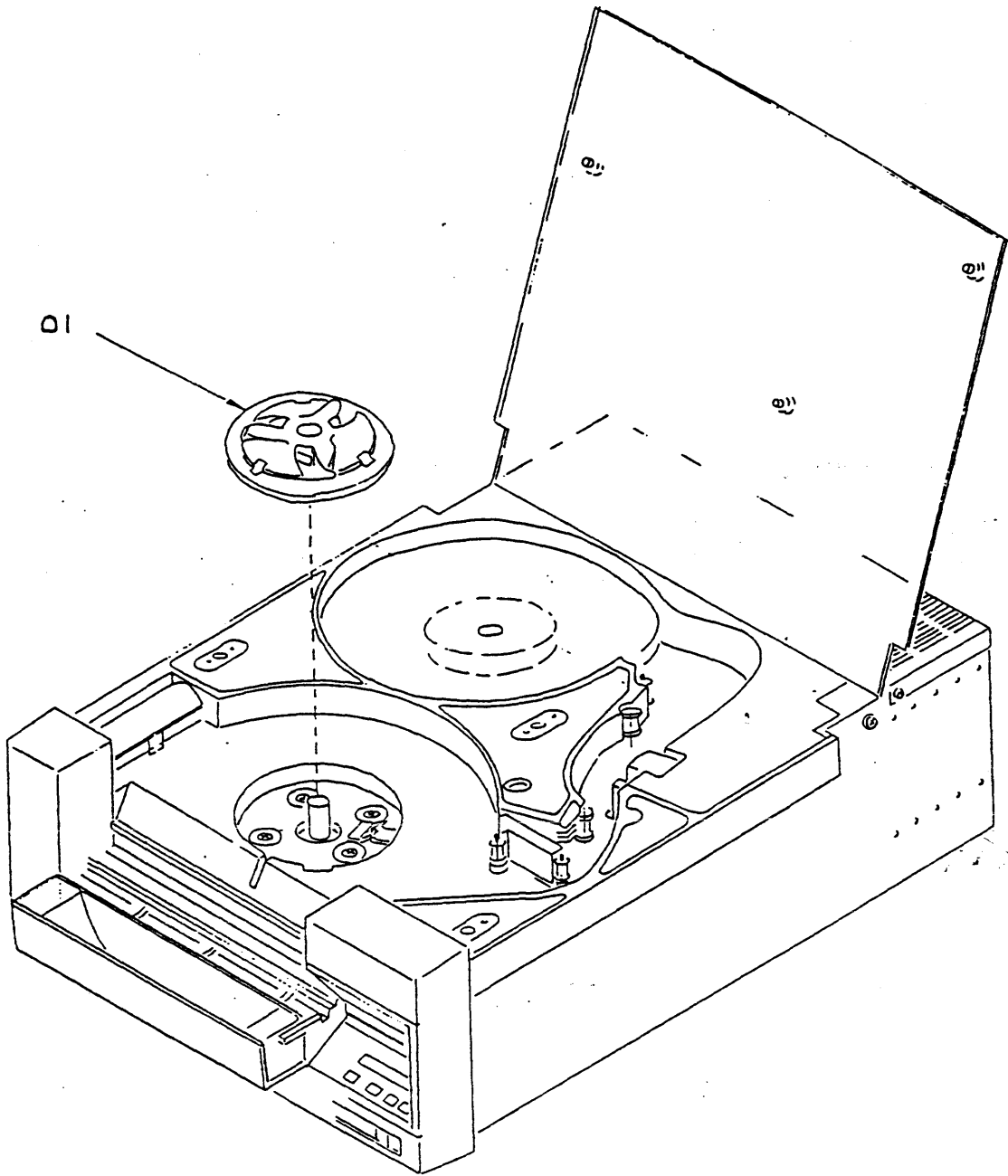

FIGURE 6.2.3 SUPPLY HUB ASSEMBLY

Figure ref.	Part Number	Description	Qty
01	95 109767 xx	Supply Hub Assembly	1

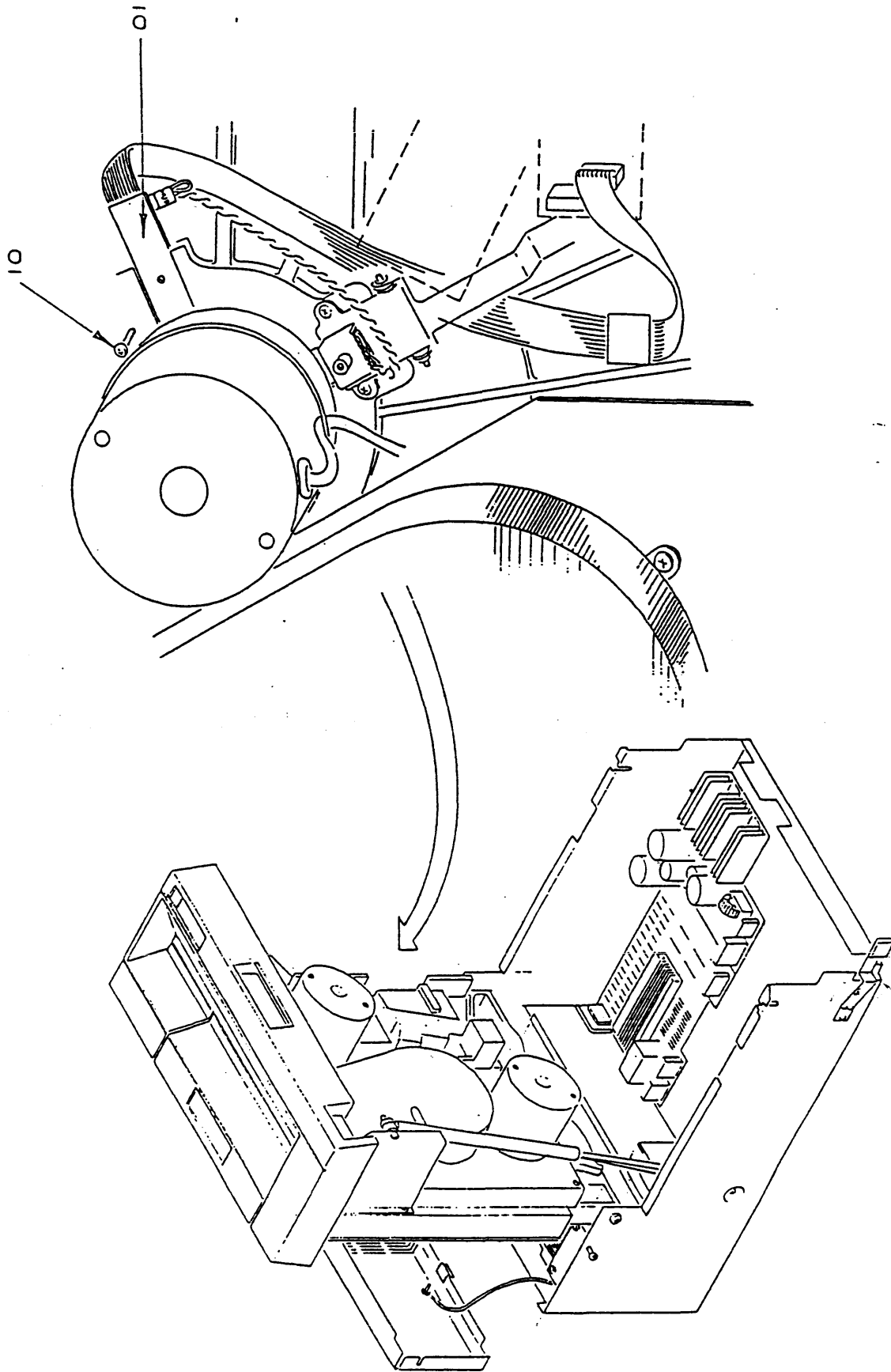

FIGURE 6.2.4 HUB SENSOR PCB

Figure ref.	Part Number	Description	Qty
01	95 120920 xx	Hub Sensor pcb	1

Attaching Hardware:

Figure ref.	Part Number	Description	Qty
10	95 041053 xx	SCR, POZ PAN, 6-32UNCx5/16	1

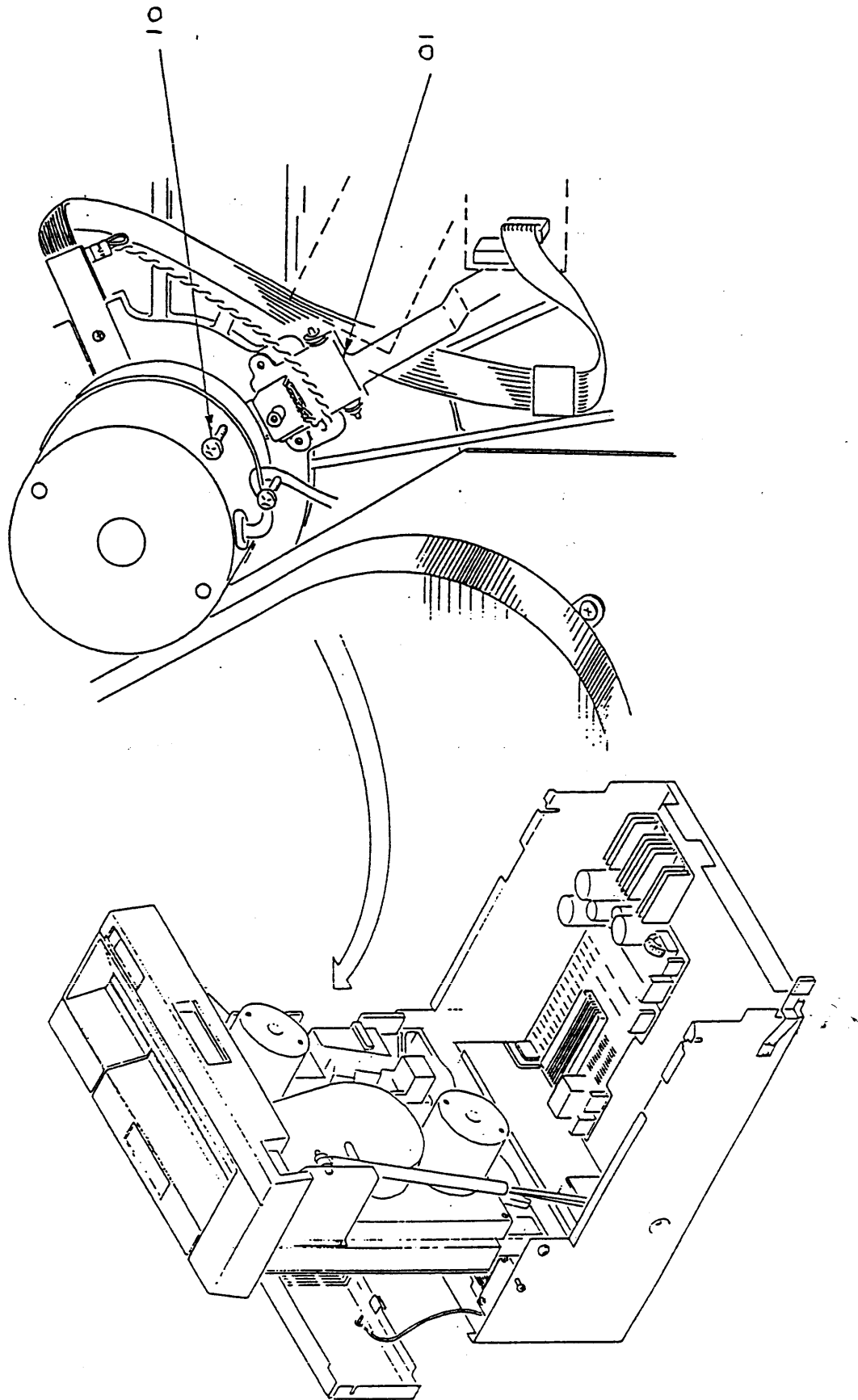

FIGURE 6.2.5 HUB LOCK ASSEMBLY

Figure ref.	Part Number	Description	Qty
01	95 121722 xx	Hub Lock Assembly	1

Attaching Hardware:

Figure ref.	Part Number	Description	Qty
10	95 041053 xx	SCR, POZ PAN, 6-32UNCx5/16	2

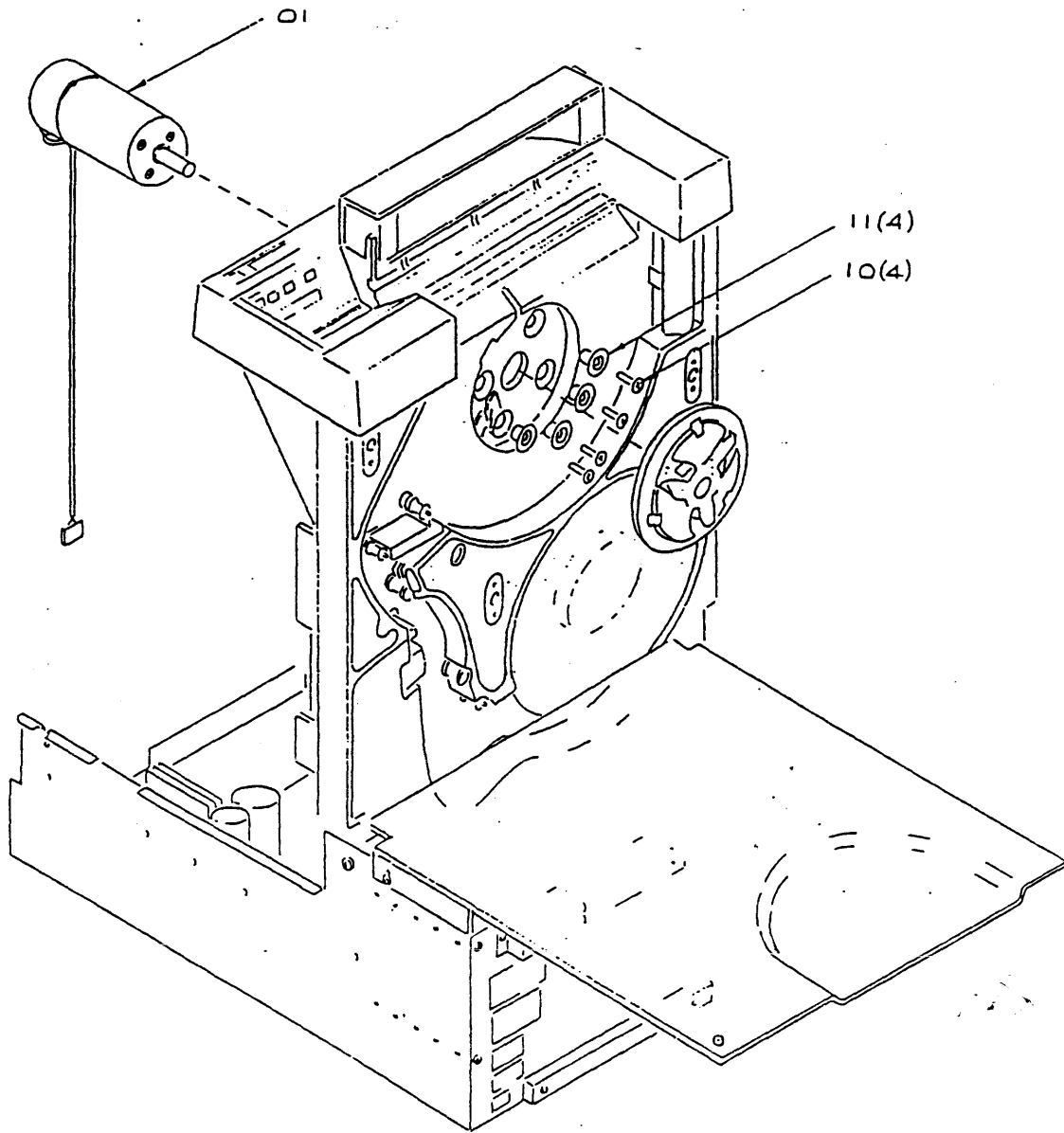

FIGURE 6.2.6 SUPPLY REEL MOTOR ASSEMBLY

Figure ref.	Part Number	Description	Qty
01	95 121721 xx	Reel Motor Assembly	1

Attaching Hardware:

Figure ref.	Part Number	Description	Qty
10	95 041623 xx	SCR, POZ CSK, 8-32UNCx3/4	4
11	95 103948 xx	BUSH, MOTOR	4

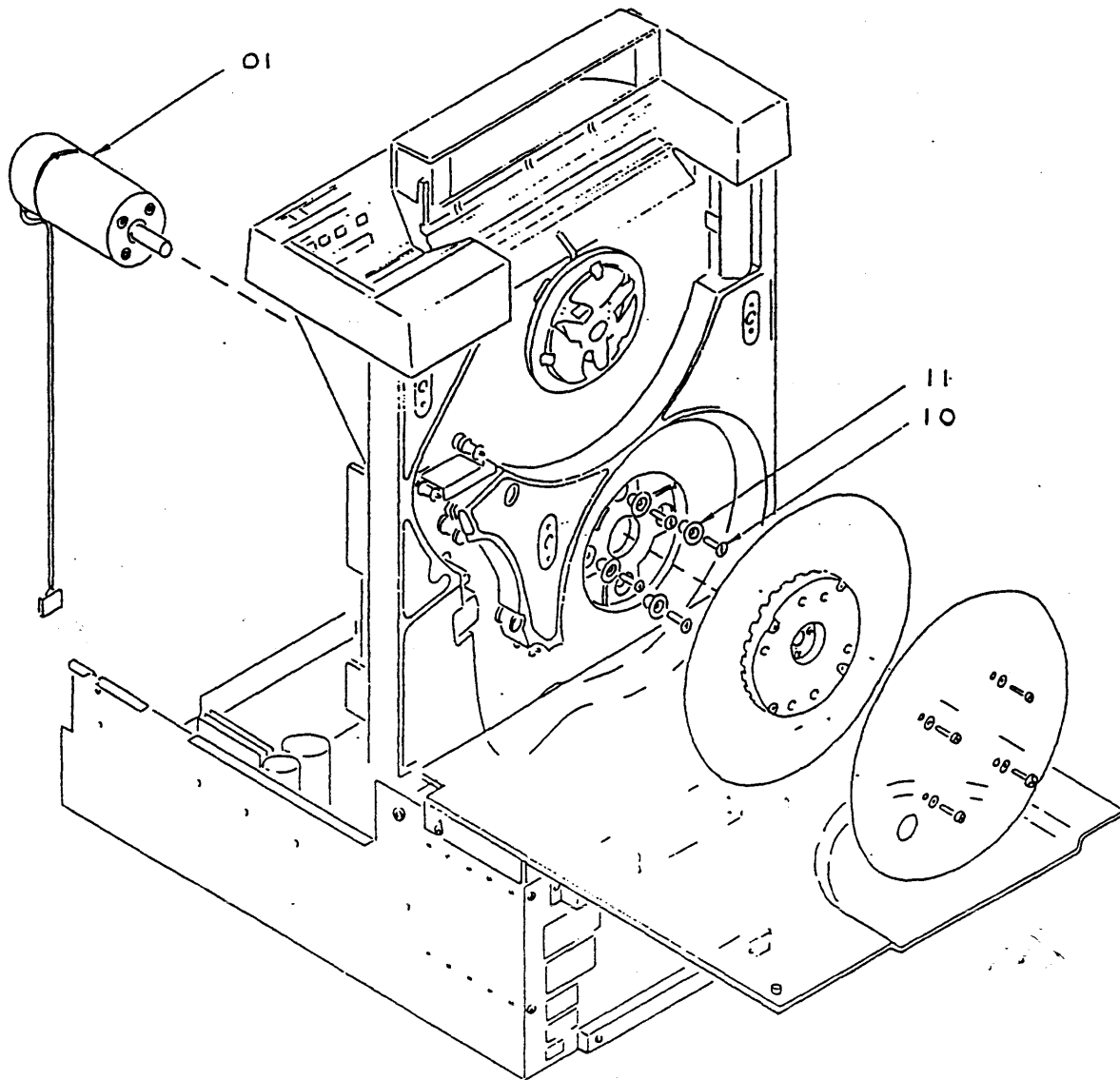

FIGURE 6.2.7 TAKE-UP REEL MOTOR ASSEMBLY

Figure ref.	Part Number	Description	Qty
01	95 121721 xx	Reel Motor Assembly	1

Assembly fixing screws are accessed by removing the take-up hub assembly.

Attaching Hardware:

Figure ref.	Part Number	Description	Qty
10	95 041623 xx	SCR, POZ CSK, 8-32UNCx3/4	4
11	95 103948 xx	BUSH, MOTOR	4

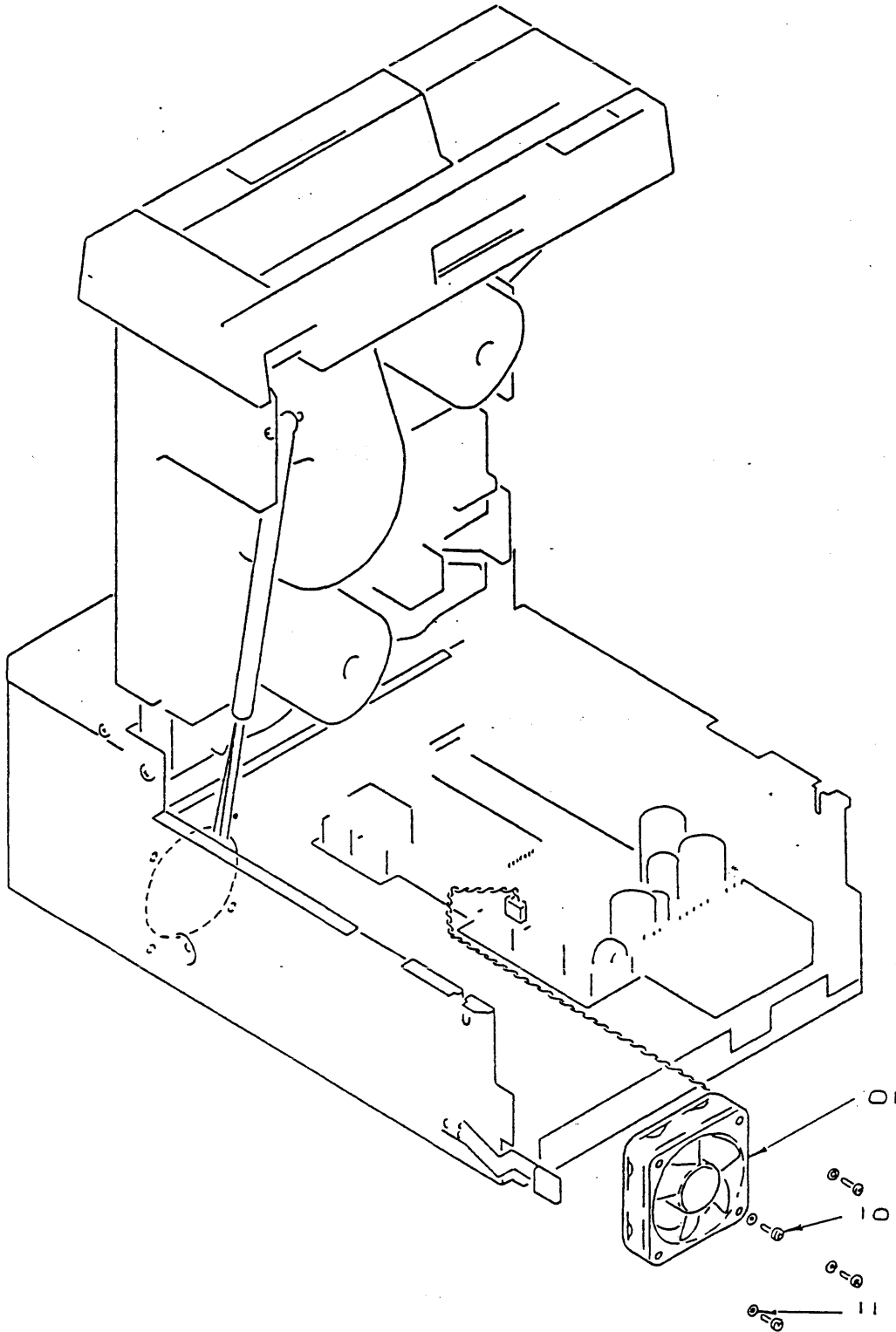

FIGURE 6.2.8 COOLING FAN ASSEMBLY

Figure ref.	Part Number	Description	Qty
01	95 121908 xx	Cooling Fan Assembly	1

Attaching Hardware:

Figure ref.	Part Number	Description	Qty
10	95 040967 xx	SCR, POZ PAN, 6-32UNCx1.5	4
11	95 041662 xx	WAS, SHP, 6UN, IT	1

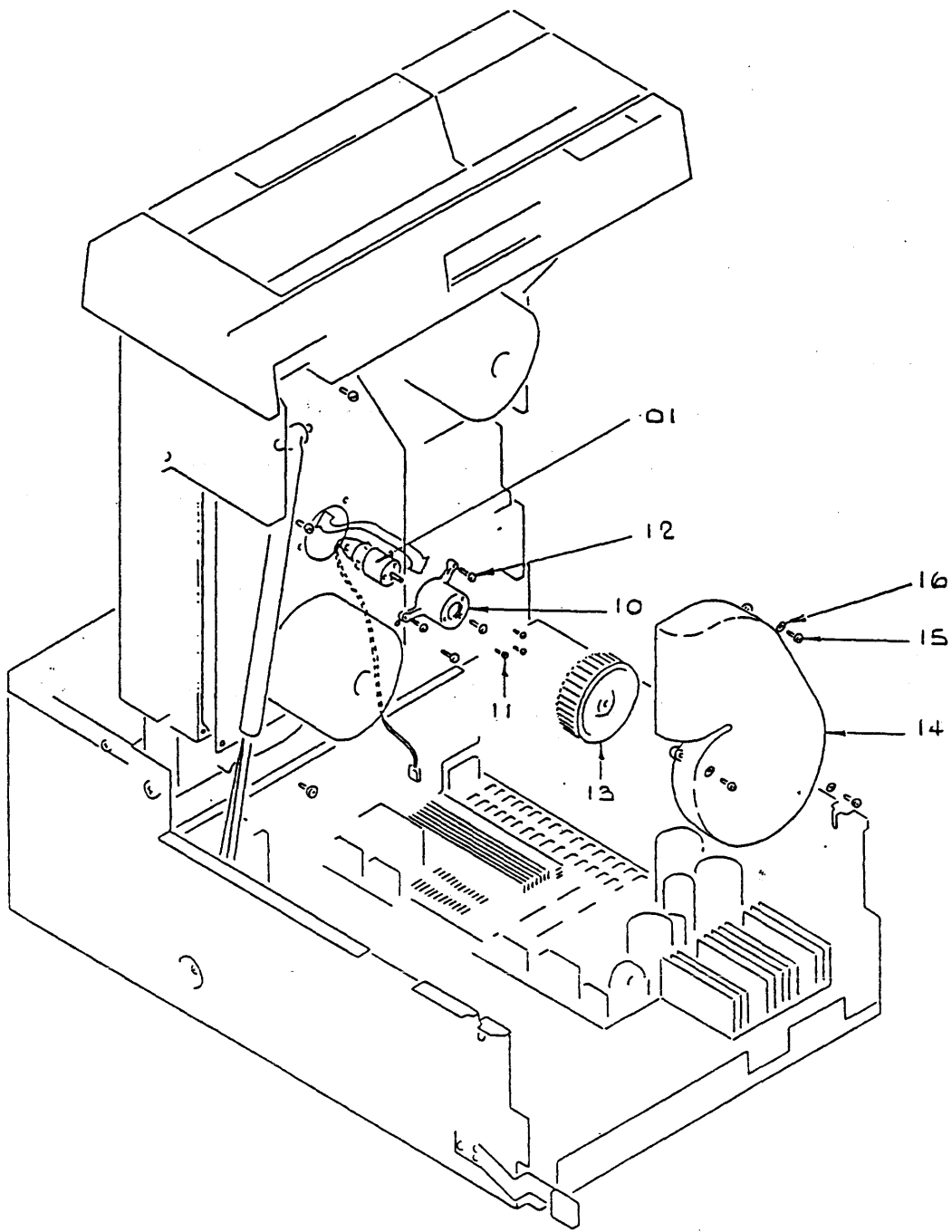

FIGURE 6.2.9 LOADING FAN ASSEMBLY

Figure ref.	Part Number	Description	Qty
01	95 121723 xx	Loading Fan Motor Assembly	1

Attaching Hardware:

Figure ref.	Part Number	Description	Qty
10	95 121852 xx	MOTOR MOUNT MOULDING	1
11	95 040086 xx	SCR, POZ PAN, M3.5, MS ZP	3
12	95 041710 xx	SCR, THR-FM, 4x1/2	3
13	95 062027 xx	FAN WHEEL, ALUMINIUM	1
14	95 121811 xx	FAN CASING MOULDING	1
15	95 041067 xx	SCR, POZ PAN, 8-32UNCx1/2	3
16	95 041596 xx	WAS, 8-32UNC, SHP, IT	3

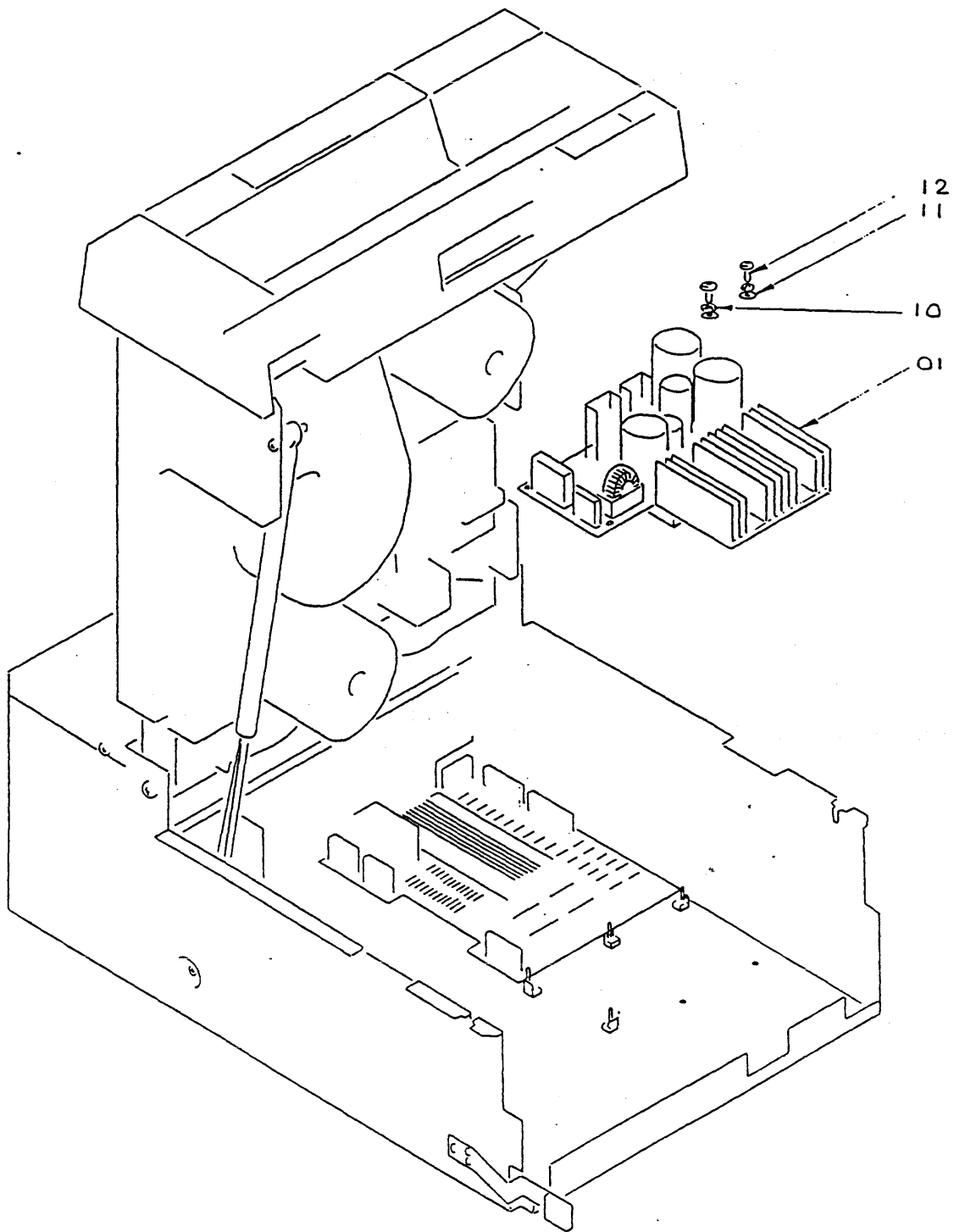

FIGURE 6.2.10 POWER SUPPLY BOARD

Figure ref.	Part Number	Description	Qty
01	95 121590 xx	Power Supply board	1

Attaching Hardware:

Figure ref.	Part Number	Description	Qty
10	95 041362 xx	WAS, SPR, SC, 6UN, MS ZP	2
11	95 041478 xx	WAS, 6UN, MS ZP	2
12	95 041057 xx	SCR, POS PAN, 6-32UNCx5/8	2

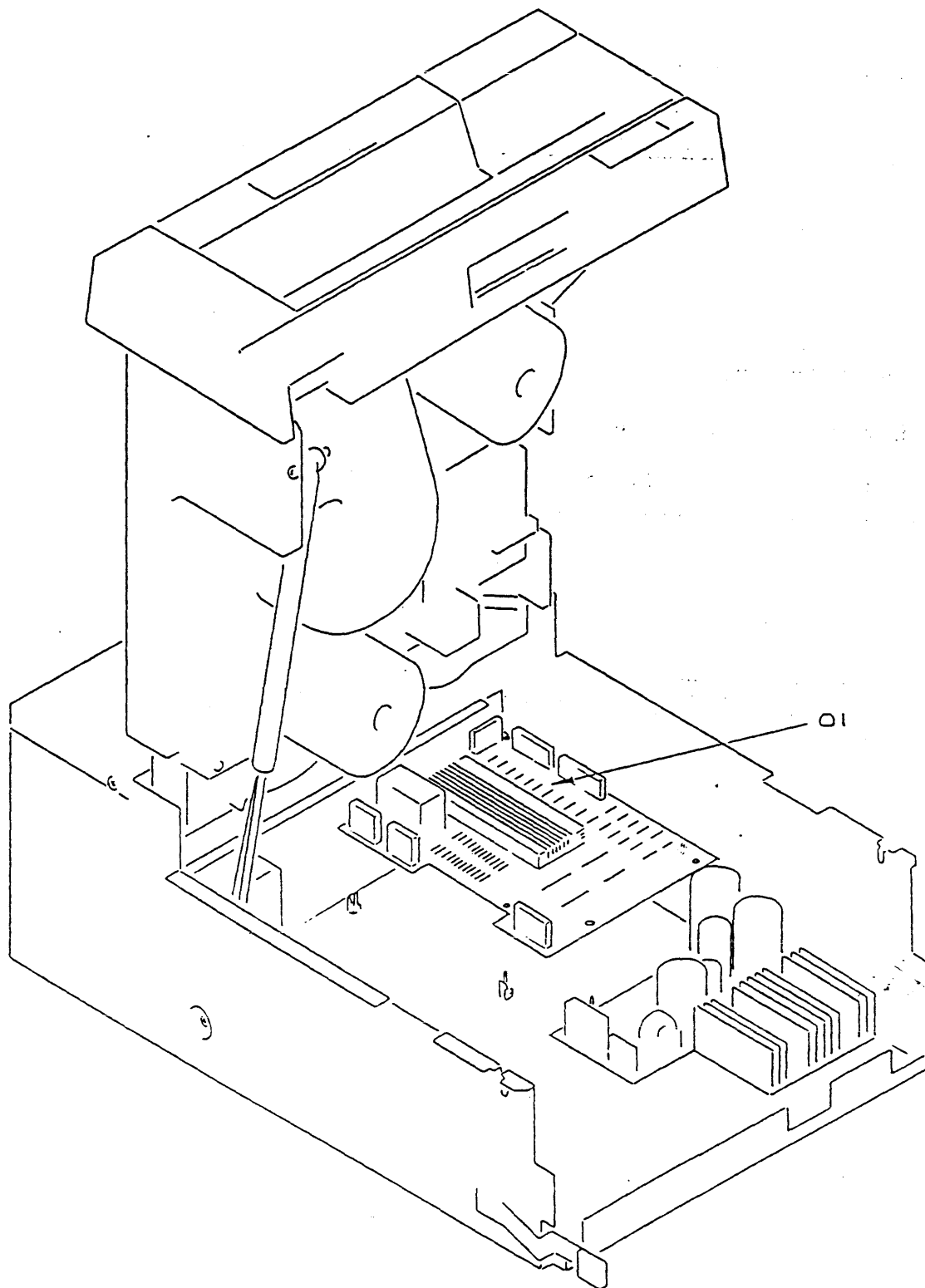

FIGURE 6.2.11 SERVO CONTROL BOARD

Figure ref.	Part Number	Description	Qty
01	95 121050 xx	Servo Control board	1

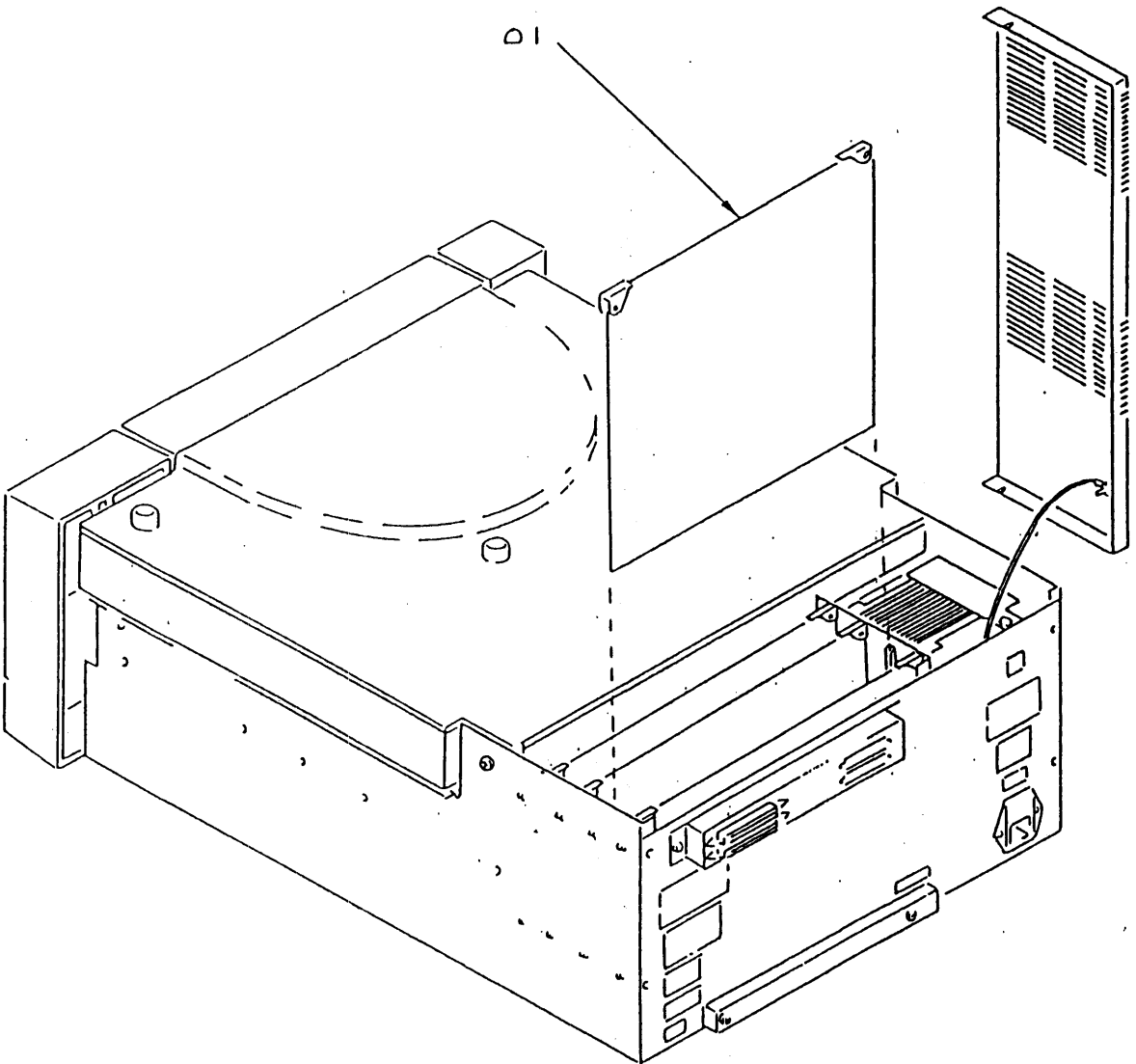

FIGURE 6.2.12 DATA CONTROL BOARD

Figure ref.	Part Number	Description	Qty
01	95 123838 xx	Data Control board	1

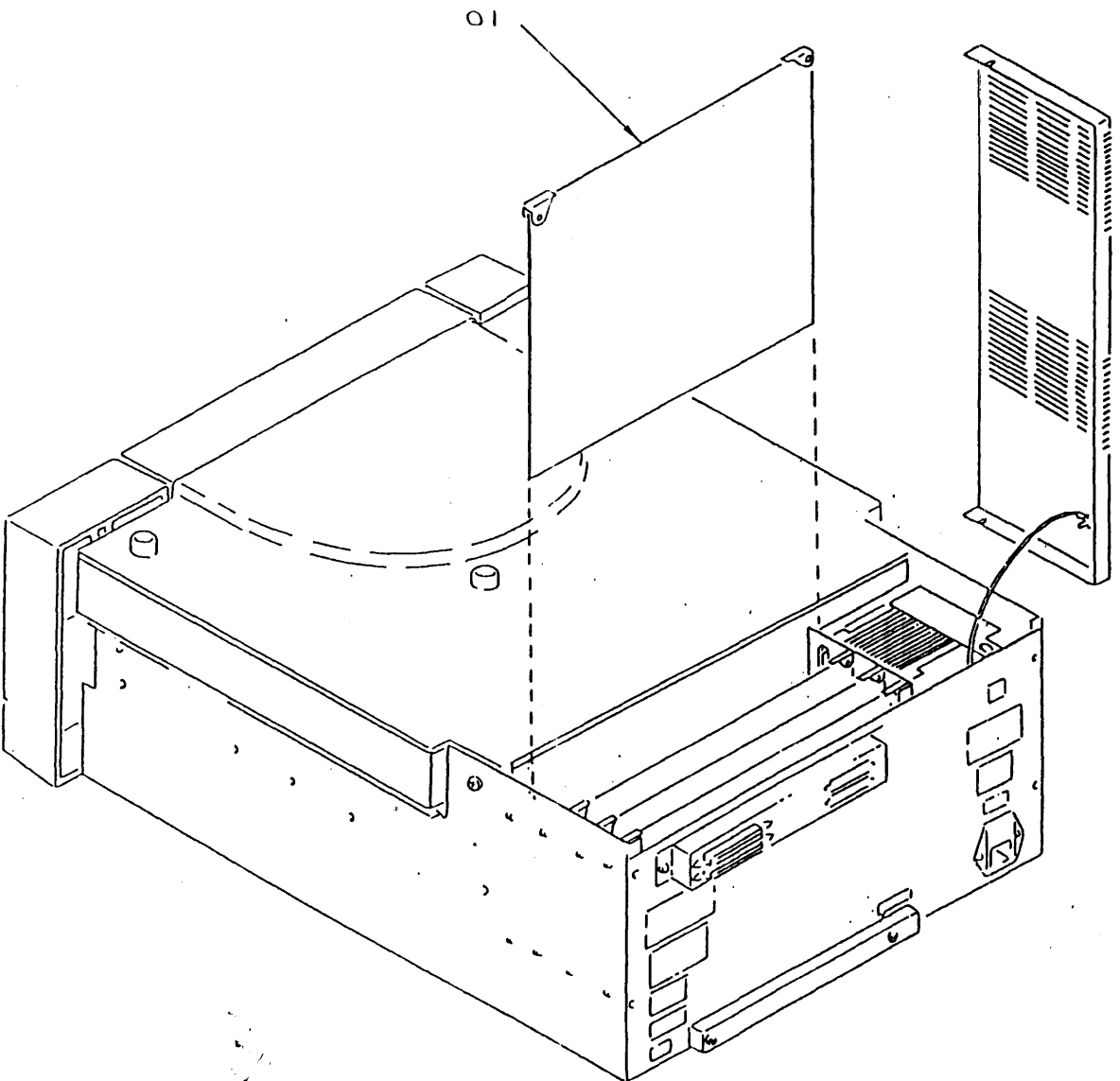

FIGURE 6.2.13 ANALOGUE DATA PATHS BOARD

Figure ref.	Part Number	Description	Qty
01	95 121710 xx	Analogue Data Paths board	1

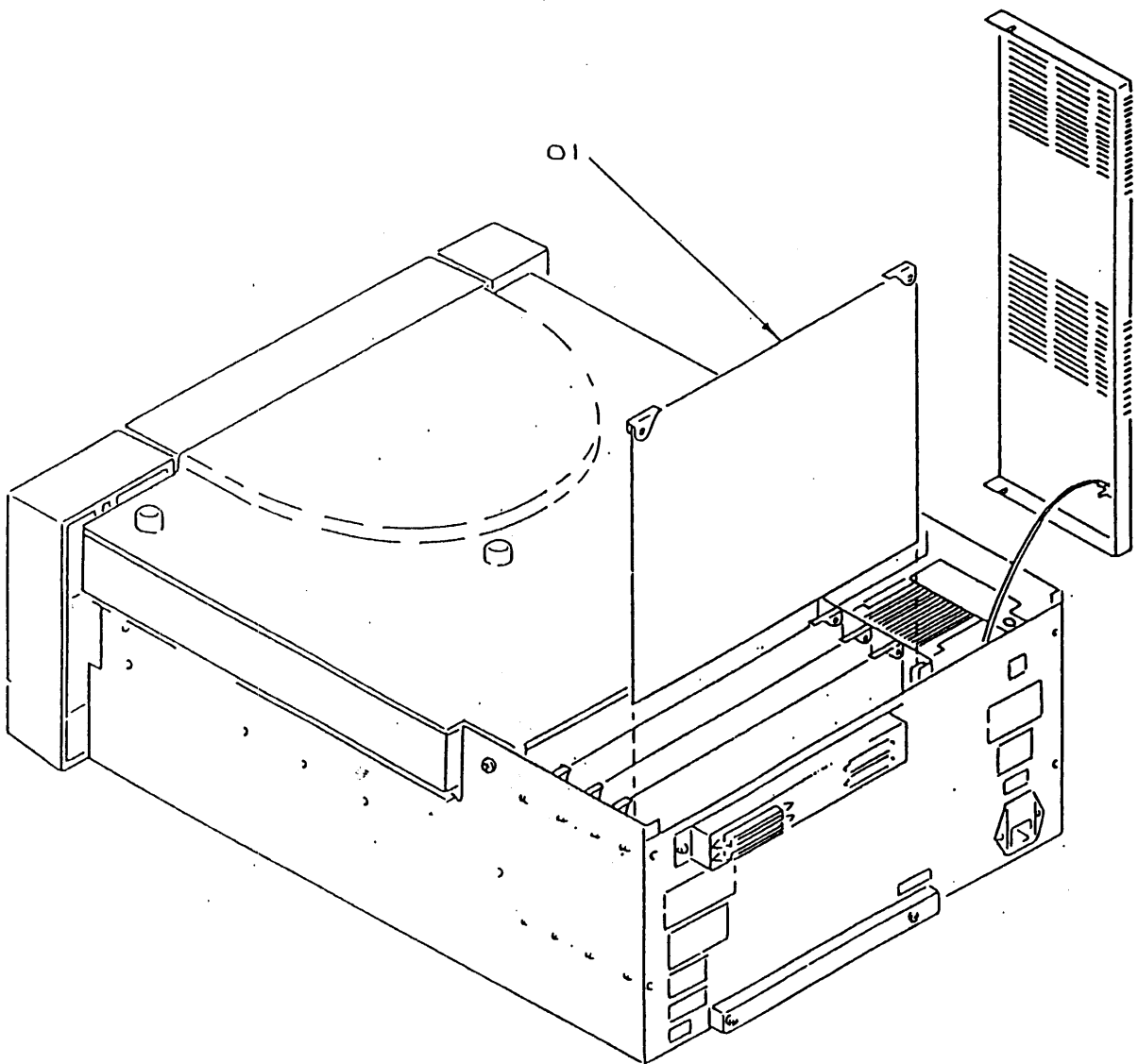

FIGURE 6.2.15 SCSI (OR PCI) BOARD

Figure ref.	Part Number	Description	Qty
01	95 123620 xx	Digital Data Paths board (42/125 ips tape speeds)	1

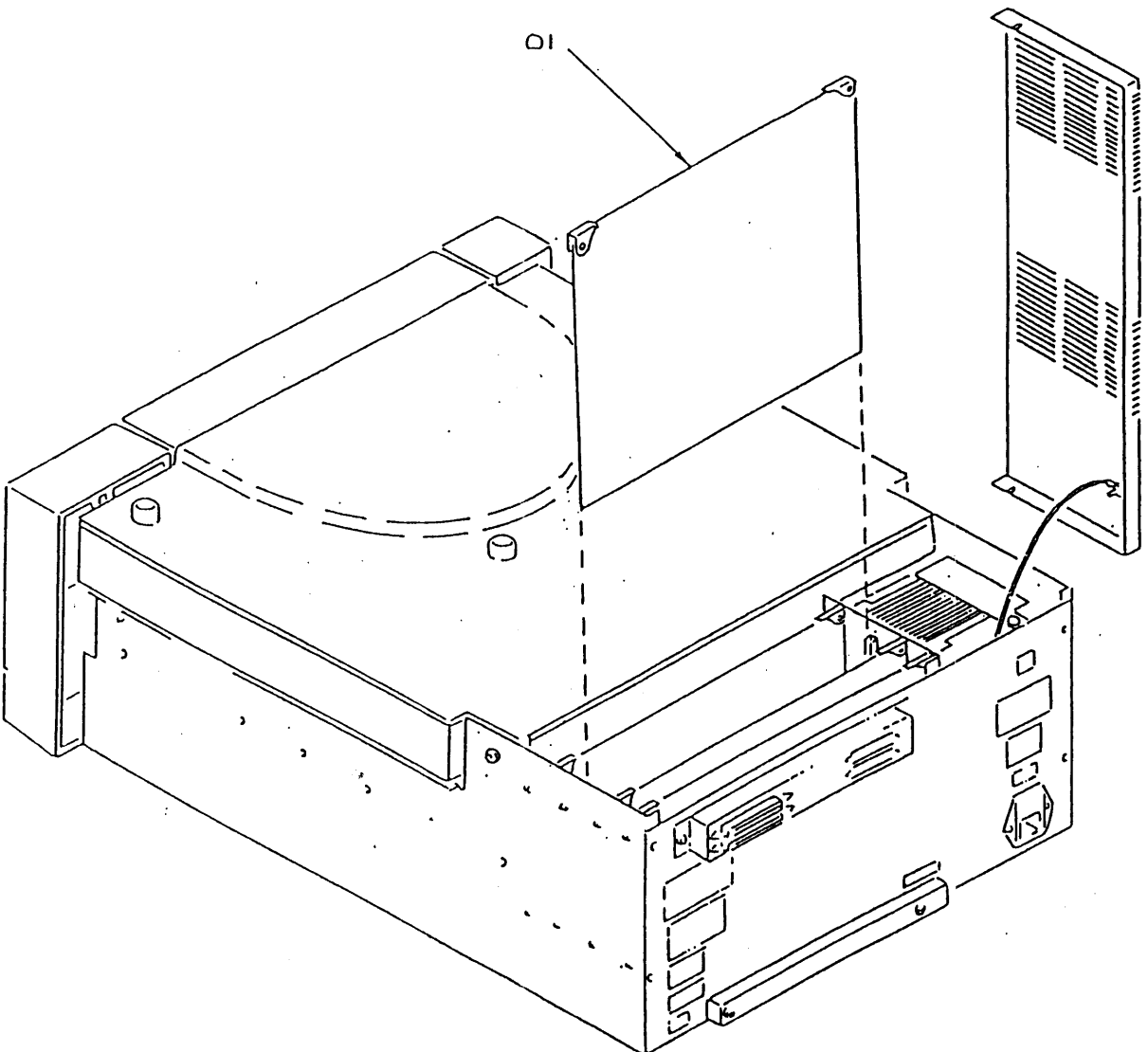

FIGURE 6.2.14 DIGITAL DATA PATHS BOARD

Figure ref.	Part Number	Description	Qty
01	95 123510 xx	SCSI board Single-ended	1
01	95 123511 xx	SCSI board Differential	1
01	95 123702 xx	PCI board (512K)	1

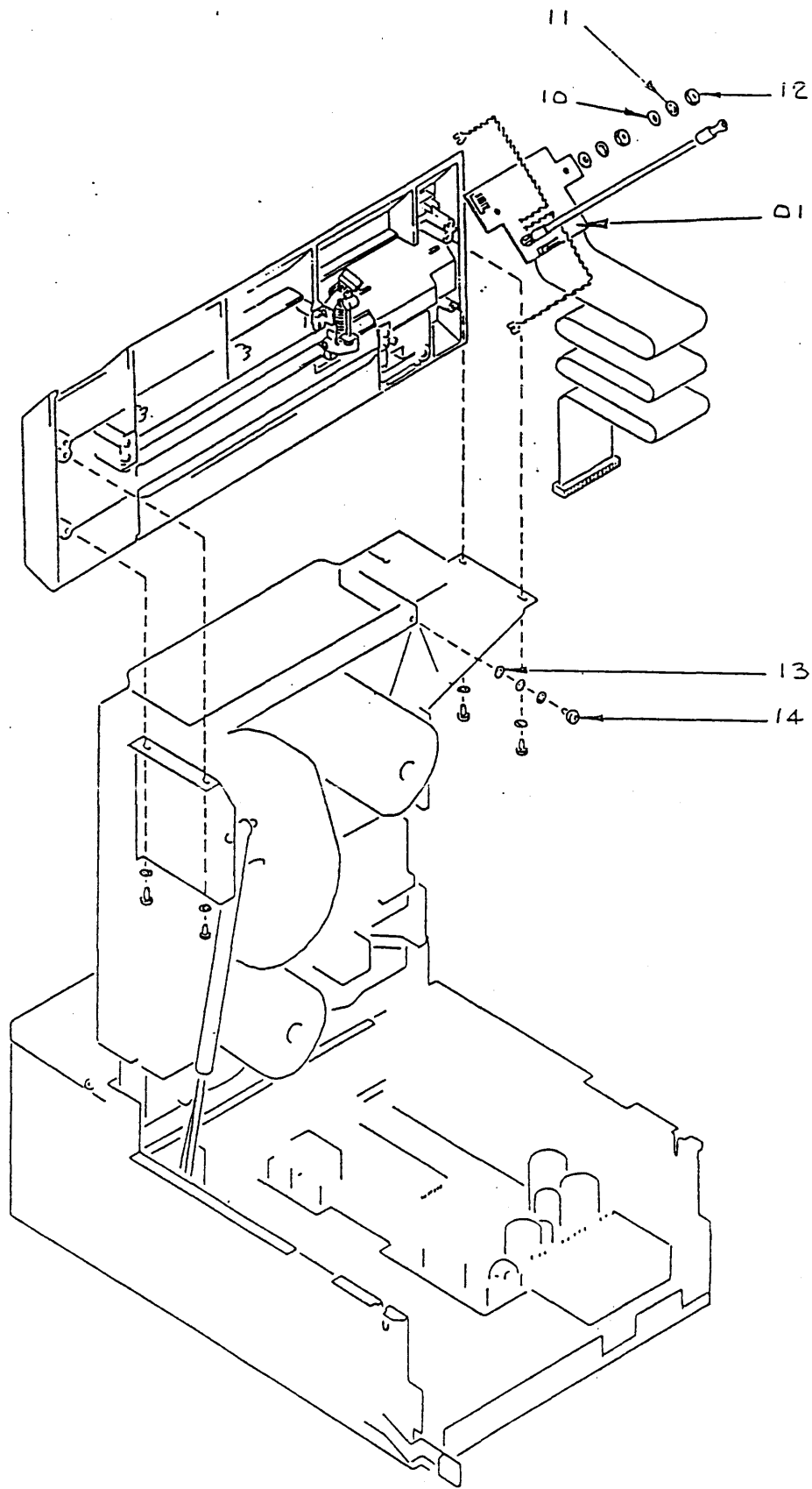

FIGURE 6.2.16 SWITCH FASCIA BOARD

Figure ref.	Part Number	Description	Qty
01	95 121160 xx	Switch Fascia pcb	1

Attaching Hardware:

Figure ref.	Part Number	Description	Qty
10	95 041361 xx	WAS, 6UN, LARGE, MS ZP	2
11	95 041662 xx	WAS, SHP, 6UN, IT	2
12	95 041347 xx	NUT, HEX, 6-32UNC, FULL	2
13	95 041596 xx	WAS, 8-32UNC, SHP, IT	7
14	95 041065 xx	SCR, POZ PAN 8-32UNCx5/8	5

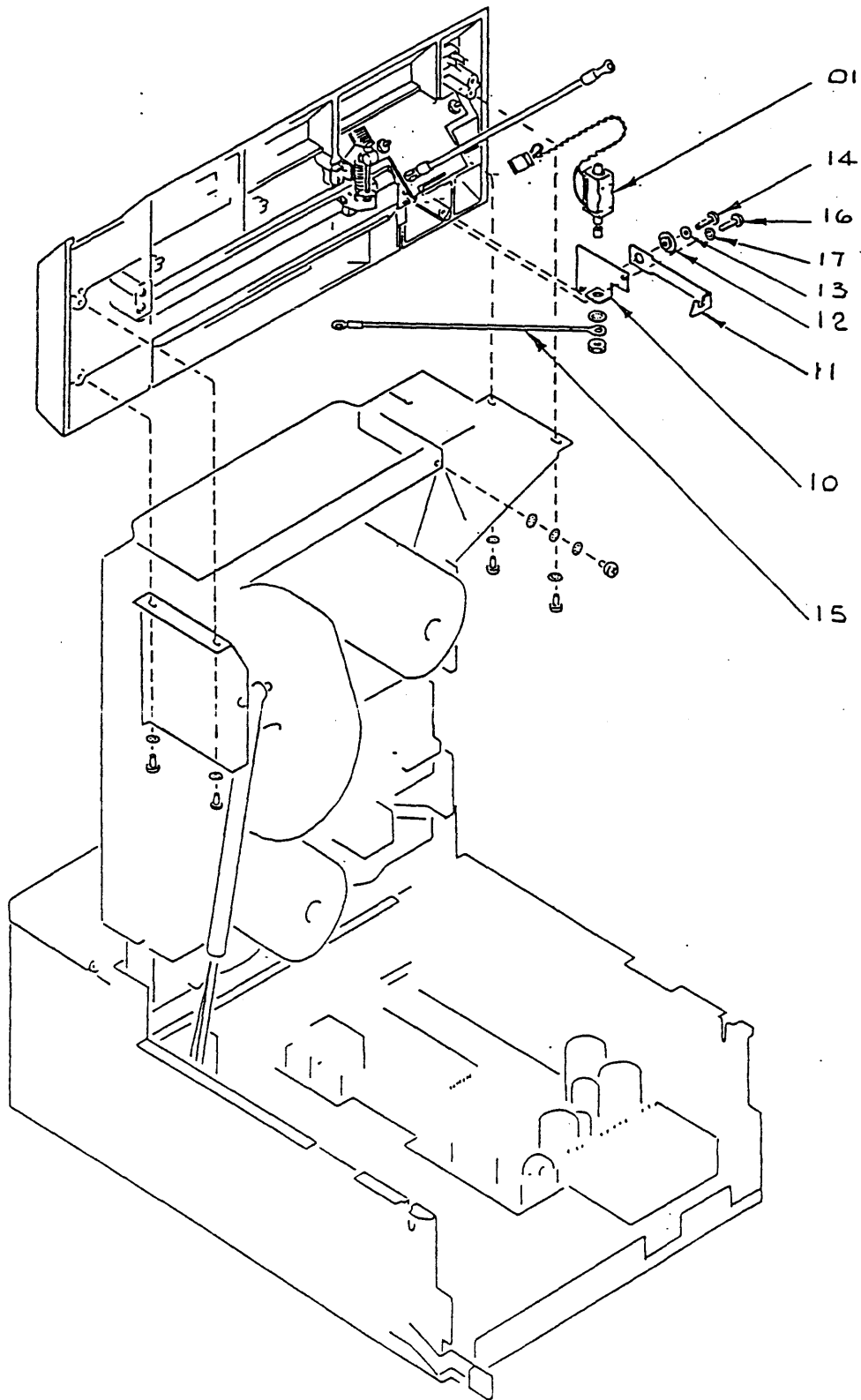

FIGURE 6.2.17 DOOR SOLENOID ASSEMBLY

Figure ref.	Part Number	Description	Qty
01	95 121906 xx	Door Solenoid Assembly	1

Attaching Hardware:

Figure ref.	Part Number	Description	Qty
10	95 123413 xx	SOLENOID MTG PLATE	1
11	95 123199 xx	DOOR LOCK ARM	1
12	95 123201 xx	PIVOT WAS, DOOR ARM	1
13	95 041601 xx	WAS, CRI, 8UN, BC ZP	2
14	95 041067 xx	SCR, POZ PAN, 8-32UNCx1/2	1
15	95 123574 xx	0V LOOM	3
16	95 041065 xx	SCR, POZ PAN 8-32UNCx5/8	1
17	95 041596 xx	WAS, 8-32UNC, SHP, IT	1

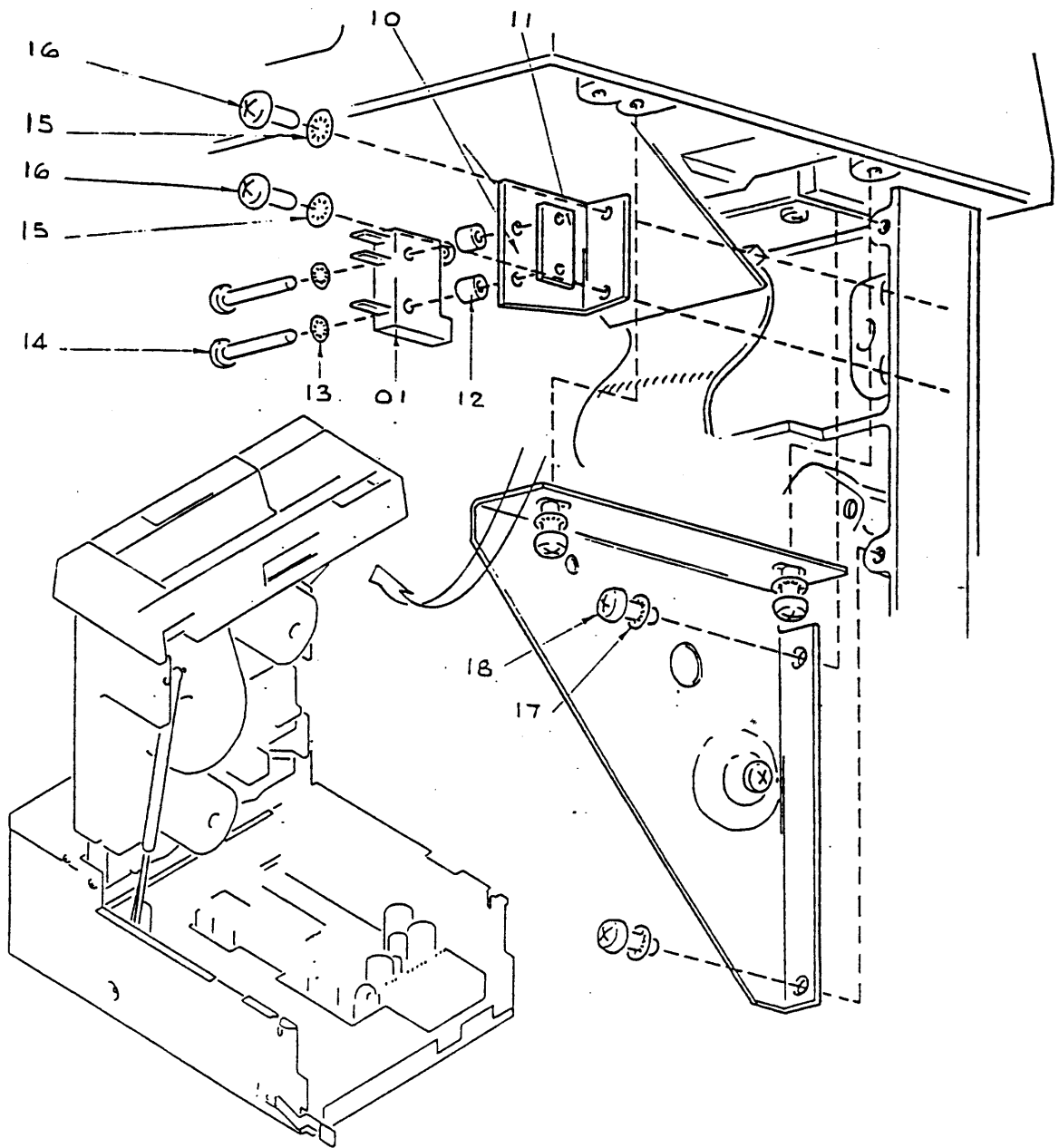

FIGURE 6.2.18 TAPE PATH COVER MICROSWITCH

Figure ref.	Part Number	Description	Qty
01	95 240040 xx	Tape Path Cover Micro-switch	1

Attaching Hardware:

Figure ref.	Part Number	Description	Qty
10	95 121881 xx	NUT PLATE	1
11	95 040552 xx	WAS, M2.5, MS ZP	2
12	95 041416 xx	WAS, SC, 2UN	2
13	95 041359 xx	SCR, POZ PAN, 2-56UNCx1/2	2

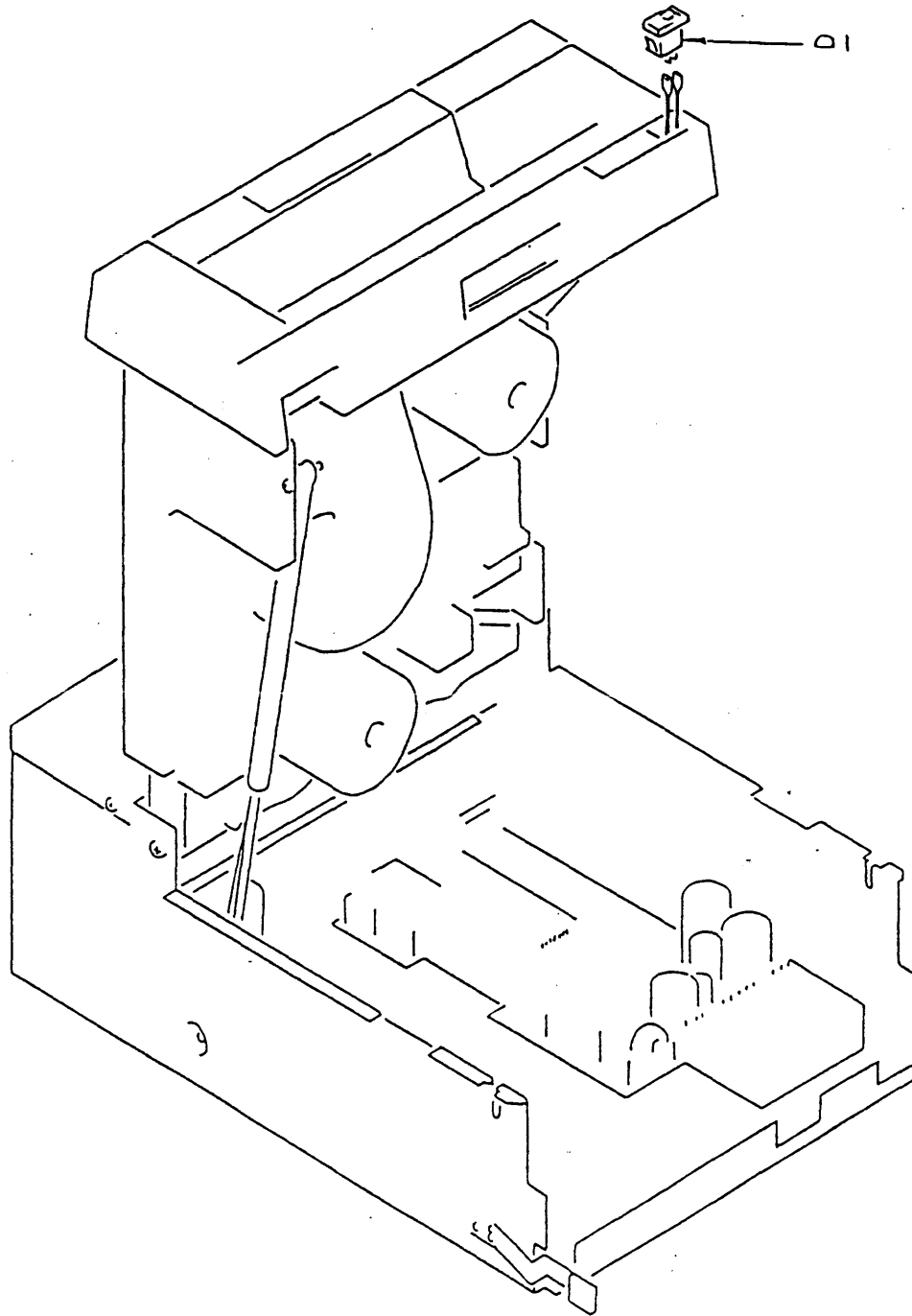

FIGURE 6.2.19 MAINS SWITCH

Figure ref.	Part Number	Description	Qty
01	95 123056 xx	Mains Switch Assembly	1

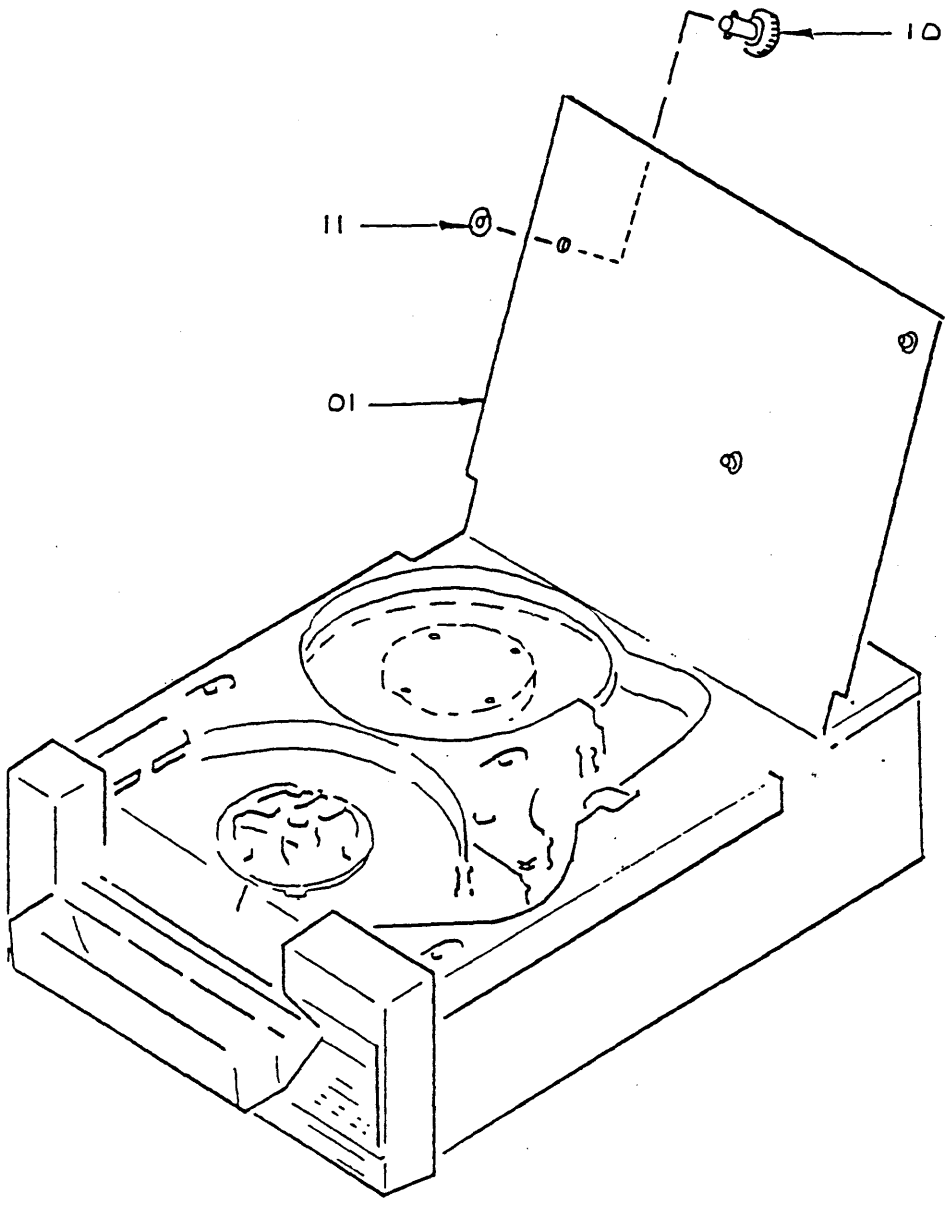

FIGURE 6.2.20 TAPE PATH COVER

Figure ref.	Part Number	Description	Qty
01	95 121697 xx	Tape Path Cover	1

Attached Hardware:

Figure ref.	Part Number	Description	Qty
10	95 020367 xx	THUMB SCREW FASTENER	1
11	95 061028 xx	RETAINING WASHER	1

This page has no technical content.

APPENDIX A - DATA ENCODING

A1 NRZ density

NRZ data encoding requires that a 1 bit is recorded as a change of magnetisation polarity, thus the channel frequency of flux changes can vary from zero to the maximum data rate.

The processing of NRZ write data involves the Write Encoder circuits compiling the CRC and LRC characters, adding them to the data stream into the PE/NRZ Encode circuit where the data is converted to NRZ format and sent to the ADP board.

The format of NRZ data on the tape is illustrated in Figure A1.1.

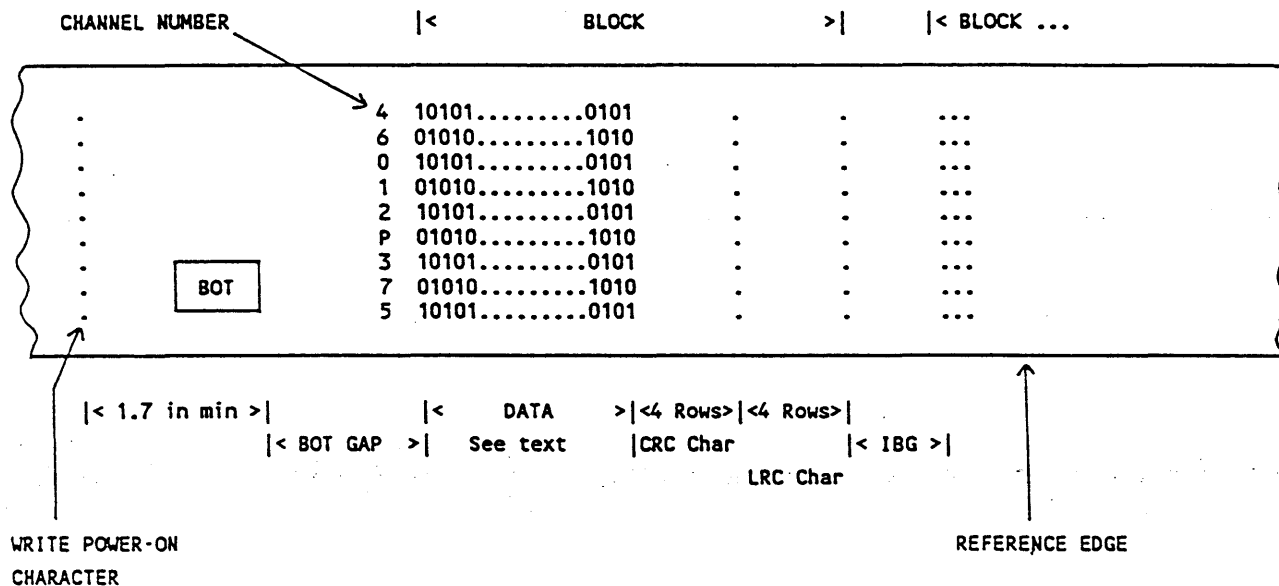

FIGURE A.1.1 NRZ TAPE FORMAT

For IBM compatibility, 9-track NRZ Drives must record at 800 bpi with the format shown above. At the end of each data block (*not* Tape Marks) a character is written to tape for possible recovery of single track errors. This character is termed the Cyclic Redundancy Check character (CRC). A Longitudinal Redundancy Check character (LRC) follows, providing an even total of flux changes (data bits) along each track, for every block. There are upper and lower limits to the number of bytes in a block.

For data interchange, the length of erased tape in the region of BOT must comply with the limits in the illustration above, the BOT gap should be within the limits 76 mm (3.0 in) to 7.6 m (25 ft).

When writing data from BOT, the Write Control circuit is set up to record the BOT gap before commencing to write the first data block.

When an NRZ file mark is required (ie the Write File Mark command has been received across the interface by the Control board), the NRZ/PE Encoding circuit is commanded to write the file mark to tape.

The format of an NRZ file mark is illustrated in Figure A1.2.

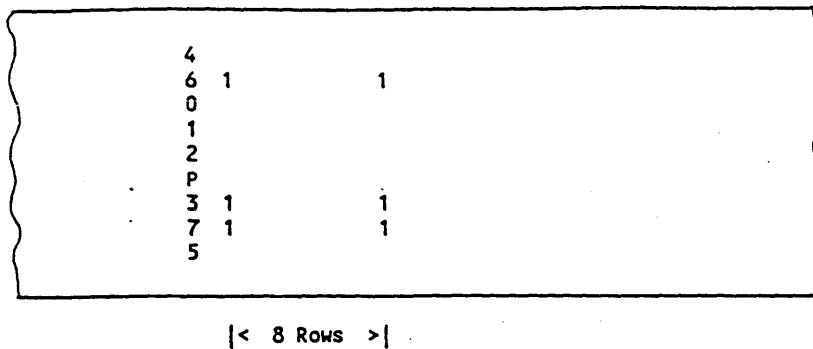

FIGURE A.1.2 NRZ FILE MARK FORMAT

Further detailed information on NRZ recording may be obtained from the relevant specifications; ANSI X3.22, or ECMA-62.

A2 PE/DPE densities

PE data encoding requires that a data 1 bit is recorded as a change of magnetisation polarity in one direction, while a 0 bit is defined as a change in the opposite direction. Thus for consecutive identical bits, there has to be an additional change of polarity (*a phase flux transition*) half-way between the nominal bit times (*data flux transitions*). For PE data (at a density of 1600 bpi), the number of flux changes per inch (fci), will be a maximum of 3200 fci and a minimum of 1600 fci.

The processing of PE write data involves the Write Encoder circuit compiling the preamble characters in advance of processing the data characters, compiling the postamble characters after the data, adding them to the data stream into the PE/NRZ Encode circuit which is switched to encode the data to PE format before sending it to the ADP board.

The format of PE data on the tape is illustrated in Figure A2.1.

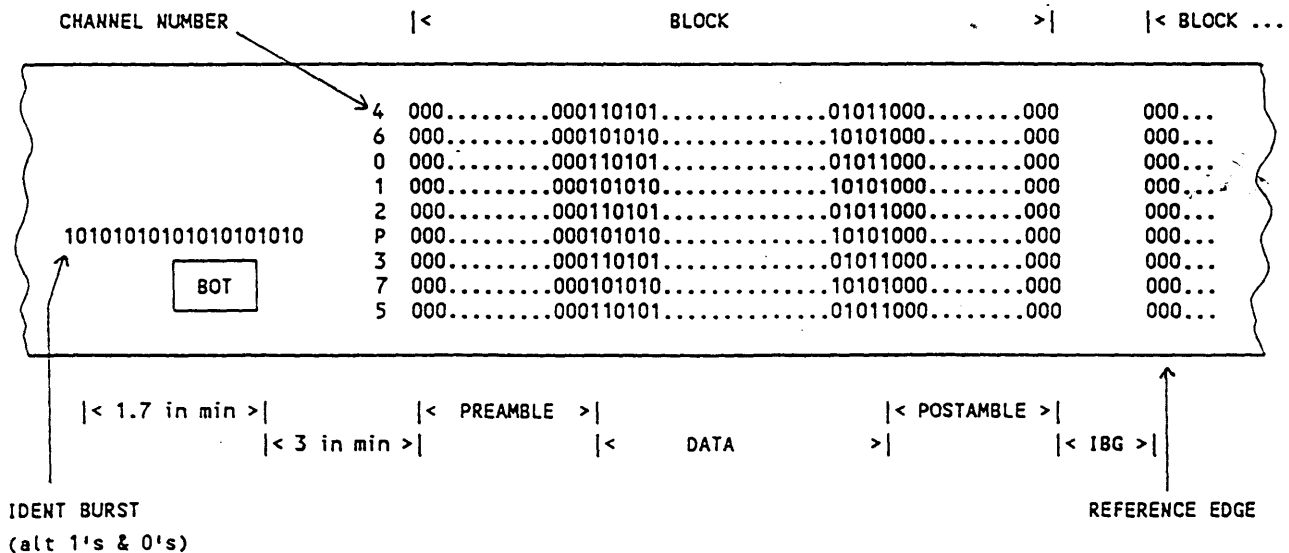

FIGURE A.2.1 PE TAPE FORMAT

Each data block must be preceded by a preamble - nominally 40 zeros followed by an 'all-ones' byte and completed by a postamble consisting of 'all-ones' byte followed by 40 zeros. This allows for synchronisation of read circuits during either forward or reverse tape motion.

Incoming data may be regarded as being handled in the following sequence:

- (i) each group of seven bytes from the interface are used to compute an Error Correction Code (ECC) byte, then the resulting eight byte data group is split into two four byte subgroups;
- (ii) each four byte subgroup is encoded into a five byte group, parity is added (the group is now 8 bits wide). This 10 X 9 group is termed a 'storage group', further storage groups are compiled until there are no more complete seven-byte input groups available;
- (iii) a special five byte 'endmark subgroup' is added;
- (iv) a 'residual subgroup' of 10 x 9 bytes is made up, including the remaining bytes from the group-by-seven operation;
- (v) in parallel with stage (i), a 'CRC subgroup' is compiled from the interface data;
- (vi) preamble and postamble subgroups are added;
- (vii) the data is written to tape, the whole assembly (including preamble and postamble) constitutes a data block.

Stage (i) is implemented by the Write Encoder circuit, stage (ii) is implemented by the 4-5 Conversion circuit, (stages (iii) & (iv) are essentially a repeat of (i) and (ii)). The CRC subgroup is implemented in the Write Encoder circuit.

In addition to the above encoding, a special 'resync burst' is written to tape every 158 data storage groups.

The format of GCR data on the tape is illustrated in Figure A3.1, beginning with the data block itself. Note that the gaps between subgroups are inserted for clarity and do not exist on tape.

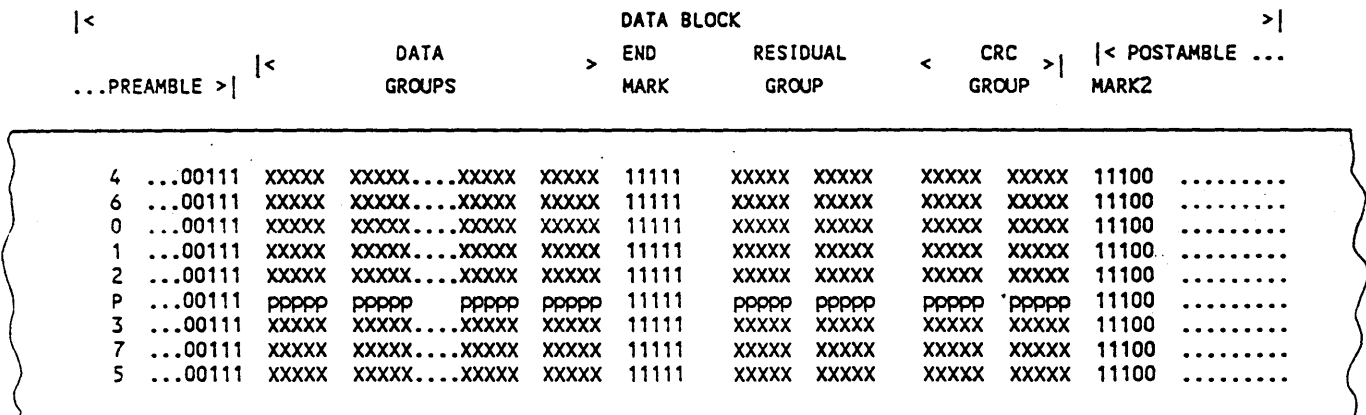

FIGURE A.3.1 GCR DATA BLOCK

The tape format of preamble and postamble is illustrated in Figure A3.2, each data block begins with a preamble and ends with a postamble which is a near mirror image of preamble to allow for synchronisation of read circuits (using the 14 all 1's subgroups) during either forward or reverse tape motion. The last character of postamble is an LRC of the entire data block.

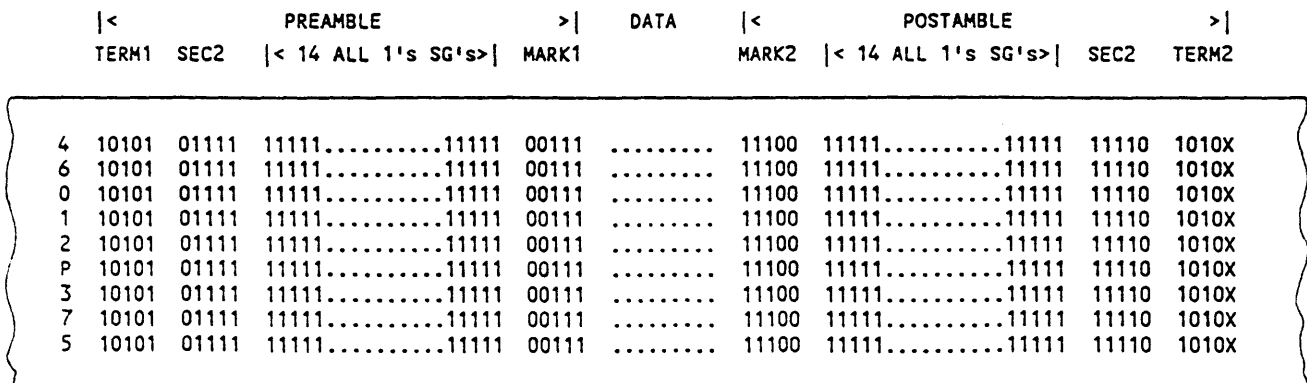

FIGURE A.3.2 GCR PREAMBLE & POSTAMBLE

The tape format near BOT is illustrated in Figure A3.3, the ARA bursts are designed to enable the drive data recovery circuits to set up the automatic gain signals; during the ARA ID burst, channels 1, 4 and 7 are dc erased.

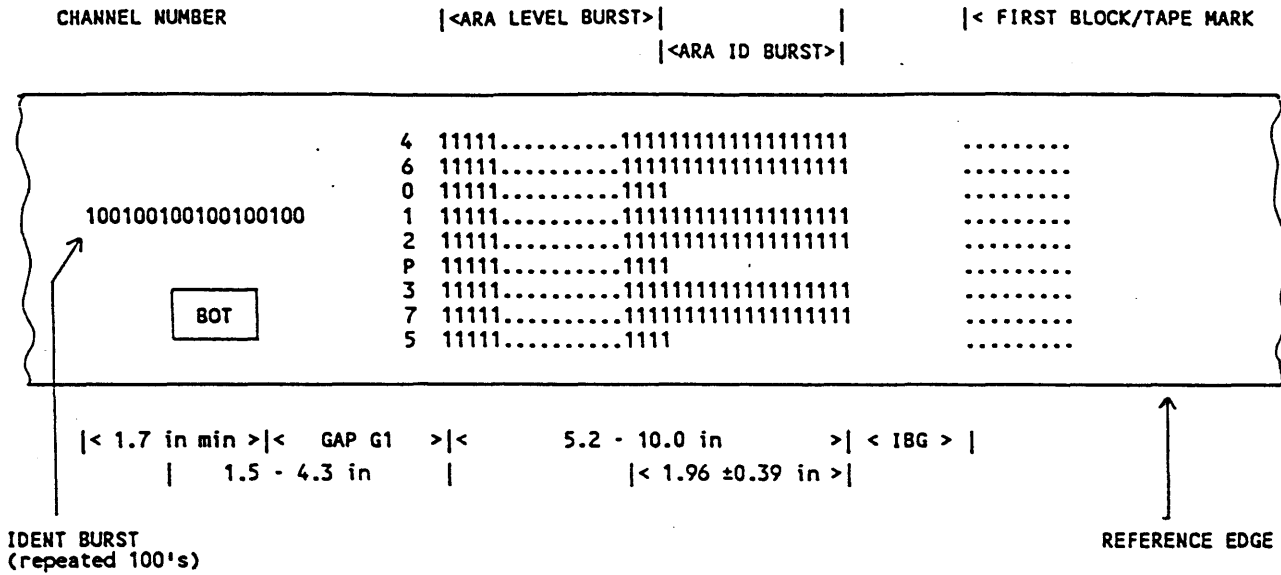

FIGURE A.3.3 GCR TAPE FORMAT, NEAR BOT

The tape format of a GCR Tape Mark is illustrated in Figure A3.4, channels 4, 1 and 3 are dc erased.

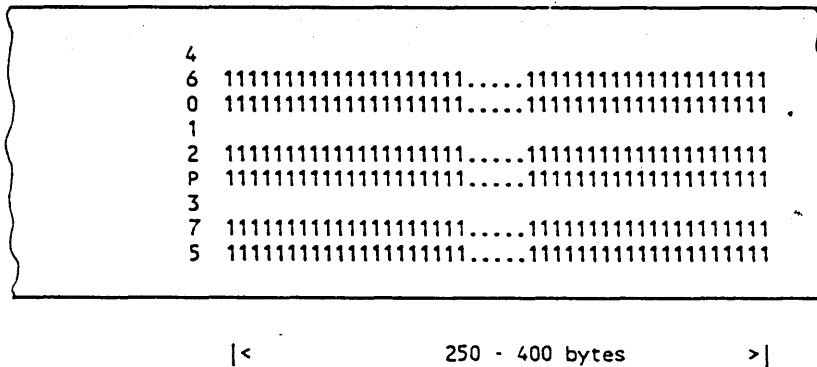

FIGURE A.3.4 GCR TAPE MARK FORMAT

Further detailed information on GCR recording may be obtained from the relevant specifications; ANSI X3.54, or ECMA-62.

This page has no technical content.

APPENDIX B - ADP MONOSTABLE SETUP

B.1 INTRODUCTION

This procedure applies to 9914's which are fitted with ADP boards of artwork issue 1 only, in response to error 52 being displayed at the conclusion of the diagnostic program 74.

B.2 PROCEDURES

Note: great care must be taken when selecting the specified address, because changing the wrong parameter could result in corruption of the 9914 operating parameters and require a re-calibration.

B.2.1 1600 bpi Low Speed

Note: the ADP board should be powered for about 5 minutes before this procedure is started, to allow the monostables to stabilise.

- (i) Load a standard amplitude tape, check that the 'analyse' function takes place;
- (ii) connect an oscilloscope to monostable test point on the ADP board; see Figure B.2.1;
- (iii) run diagnostic program 42 to set 1600 bpi;
- (iv) run diagnostic program 12 to set low speed;
- (v) run diagnostic program 78, the display should show '80 00' with the last two zeros flashing;
- (vi) change this address to '81 43', using the operator panel buttons as follows:
'tens' and 'units' to set a significant pair of digits, 'density' to toggle between pairs;
- (vii) when the display shows '81 43', press DIAG to display the two-digit hex value stored in that address;

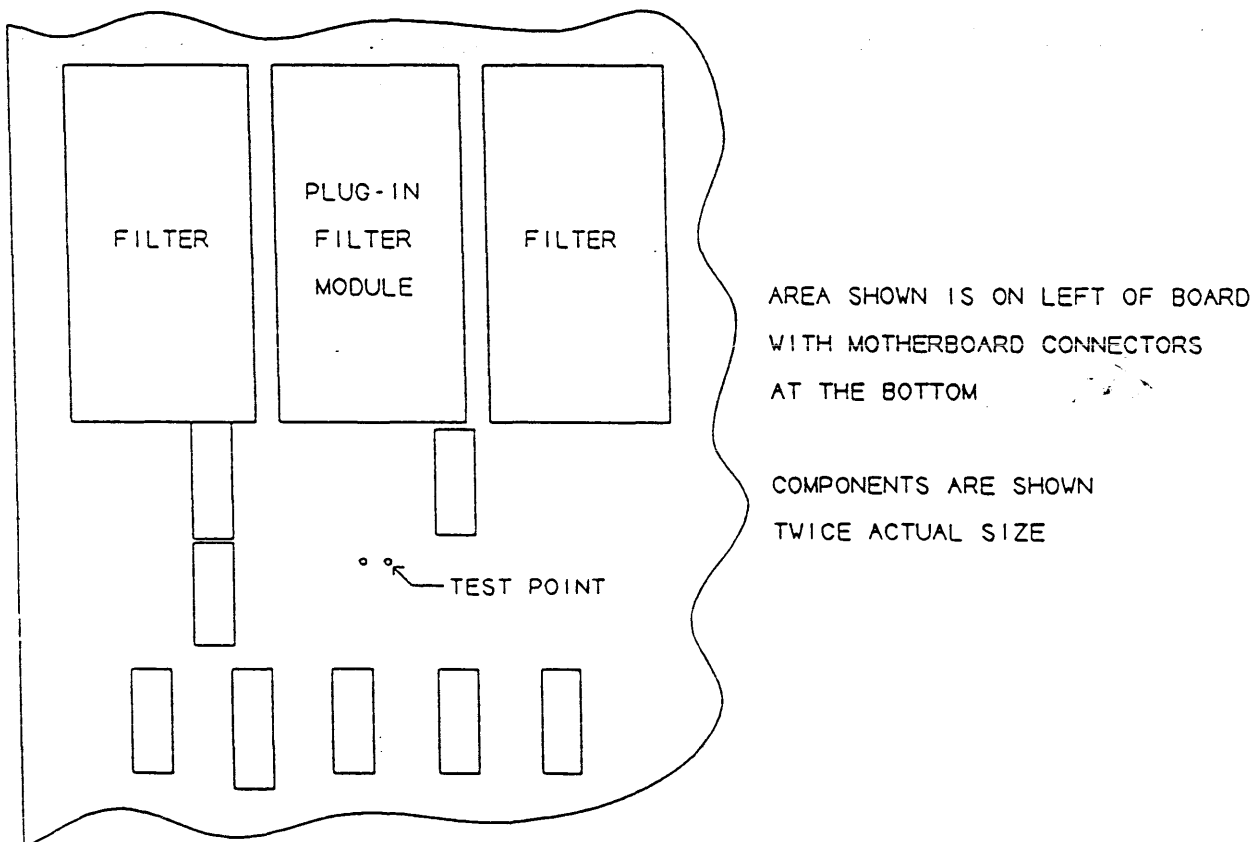

FIGURE B.2.1 ADP MONOSTABLE TEST POINT

- (viii) examine the oscilloscope trace for channel 2, this must be adjusted to a 50/50 mark/space ratio or within the limits of Figure B.2.2. Alter the mark/space ratio by pressing the 'tens' and 'units' buttons until Figure B.2.2 limits are achieved. Press 'run/stop' to store the new value.

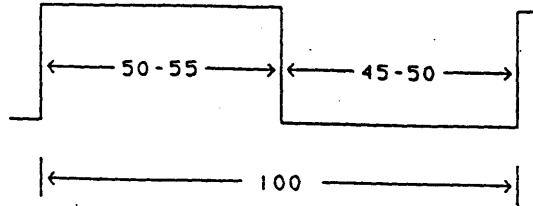

FIGURE B.2.2 ADP MONOSTABLE WAVEFORM

B.2.2 1600 bpi High Speed

- (i) run diagnostic program 11 to set high speed;
- (ii) run diagnostic program 78, to display '80 00';
- (iii) change this address to '81 C3', as in B.2.1 (vi) above;
- (iv) when the display shows '81 C3', press DIAG to display the two-digit hex value;
- (v) repeat the mark/space re-setting procedure of B.2.1 (viii) above.

B.2.3 3200 bpi

- (i) run diagnostic program 43 to set 3200 bpi;
- (ii) run diagnostic program 12 to set low speed;
- (iii) run diagnostic program 78, to display '80 00';
- (iv) change this address to '81 E3', as in B.2.1 (vi) above;
- (v) when the display shows '81 E3', press DIAG to display the two-digit hex value;
- (vi) repeat the mark/space re-setting procedure of B.2.1 (viii) above.

B.2.4 6250 bpi Low Speed

- (i) run diagnostic program 44 to set 6250 bpi;
- (ii) run diagnostic program 78, to display '80 00';
- (iii) change this address to '81 83', as in B.2.1 (vi) above;
- (iv) when the display shows '81 83', press DIAG to display the two-digit hex value;
- (v) repeat the mark/space re-setting procedure of B.2.1 (viii) above;

B.2.5 6250 bpi High Speed

- (i) run diagnostic program .11 to set high speed;
- (ii) run diagnostic program 78, to display '80 00';
- (iii) change this address to '82 03', as in B.2.1 (vi) above;
- (iv) when the display shows '82 03', press DIAG to display the two-digit hex value;
- (v) repeat the mark/space re-setting procedure of B.2.1 (viii) above;

B.2.6 Conclusion

The ADP monostables have now been set up, press DIAG to exit diagnostic mode.

Set power off, wait a few seconds, set power on again. This kills the service key.

This page has no technical content