

**Operation and Maintenance
Manual**

KENNEDY

A Division of Shugart Corporation

**Auto-Load Digital
Tape System**

**Model
9600B / 9650B**

FCC CERTIFIED COMPUTER EQUIPMENT

This equipment, freestanding with shielded Data and Control Cables, complies with Part 15, Subpart J of FCC Rules Governing Class A Computing Devices Operated In A Commercial Environment. However, the equipment generates radio frequency energy and, when operated in a residential area, the user must take adequate precautions against interference to radio communications.

Copyright ©1989 by Kennedy Company

All rights reserved. No part of this work covered by the copyright hereon may be reproduced or copied in any form or by any means - graphic, electronic, or mechanical, including photocopying, taping, or information storage and retrieval systems - without written permission of Kennedy Company.

TABLE OF CONTENTS

SECTION I - GENERAL DESCRIPTION AND APPLICATION DATA	<u>Page</u>	<u>Section</u>	<u>Page</u>
1.1 General Description.....	1-1	1.4.3.6 Write File Mark	1-16
1.1.1 Host Interfaces	1-1	1.4.3.7 Fixed Length Erase	1-16
1.1.2 Microcomputer Based Design.....	1-1	1.4.3.8 Data Security Erase	1-16
1.1.3 Diagnostics & Fault Isolation.....	1-1	1.4.3.9 Space Forward and Space Reverse	1-16
1.2 Specifications	1-2	1.4.3.10 File Mark Search Fwd/Rev	1-17
1.2.1 Operational Specifications	1-2	1.4.3.11 Erase Variable.....	1-17
1.2.2 Physical/Environmental Specs	1-4	1.4.3.12 Density Select.....	1-17
1.3 Interface Specifications.....	1-5	1.5 Host Interface Timing	1-17
1.3.1 General	1-5	SECTION II - INSTALLATION AND OPERATION	
1.3.2 Interface Connectors	1-5	2.0 Introduction	2-1
1.3.3 Interface Signal Character.....	1-5	2.1 Unpacking	2-1
1.3.4 Interface Cables.....	1-5	2.2 Inspection	2-1
1.3.5 Receiver/Driver Configuration.....	1-5	2.3 Cabling and Daily Chaining Requirements	2-1
1.3.6 Daisy Chaining	1-6	2.4 Installation.....	2-5
1.4 Interface Input and Output Signals.....	1-7	2.4.1 Table-Top Installation	2-5
1.4.1 Interface Input Signals.....	1-8	2.4.2 Rack-Mount Installation	2-5
1.4.1.1 Trans. Addr/Formatter Addr.....	1-8	2.4.2.1 Rail Assy Component Checkout..	2-5
1.4.1.2 Initiate Command - GO	1-9	2.4.2.2 Mounting Procedure	2-5
1.4.1.3 Reverse	1-9	2.5 Power Up and Initial Checkout.....	2-9
1.4.1.4 Write.....	1-9	2.5.1 Line Voltage.....	2-9
1.4.1.5 Write File Mark.....	1-9	2.5.1.1 AC Line Voltage	2-9
1.4.1.6 Edit.....	1-9	2.5.1.2 DC Line Voltage	2-10
1.4.1.7 Erase.....	1-9	2.5.2 Power Up	2-11
1.4.1.8 High Speed.....	1-9	2.5.3 Checkout	2-11
1.4.1.9 Long Gap	1-10	2.5.3.1 Loading Tape	2-11
1.4.1.10 Rewind.....	1-10	2.5.3.2 Load Details	2-11
1.4.1.11 Off-Line/Unload	1-10	2.5.3.3 Checkout Continued	2-12
1.4.1.12 Last Word.....	1-10	2.5.3.4 Motion Test Summary.....	2-13
1.4.1.13 Formatter Enable.....	1-10	2.5.4 Unit Selection	2-13
1.4.1.14 Write Data Lines.....	1-10	2.5.5 Data Density - Introduction.....	2-15
1.4.1.15 Load On Line.....	1-11	2.6 Operating Instructions.....	2-17
1.4.2 Interface Outputs	1-11	2.6.1 Operating Procedure	2-17
1.4.2.1 Formatter Busy	1-11	2.6.2 Operation Notes	2-17
1.4.2.2 Data Busy	1-11	SECTION III - FUNCTIONAL DESCRIPTION	
1.4.2.3 Hard Error	1-11	3.0 General.....	3-1
1.4.2.4 Corrected Error PE, DDPE).....	1-12	3.1 System Description	3-1
1.4.2.5 Check Char Gate (NRZI only)..	1-12	3.1.1 Overview	3-1
1.4.2.6 Ident Burst (PE, DDPE).....	1-12	3.1.2 Formatter Board.....	3-1
1.4.2.7 File Mark.....	1-12	3.1.3 Read Preamp Board	3-3
1.4.2.8 Write Strobe.....	1-13	3.1.4 Read Analog Board	3-3
1.4.2.9 Read Strobe	1-13	3.1.5 Read/Write Digital Board.....	3-3
1.4.2.10 Read Data Lines	1-13	3.1.6 Drive Electronics Board	3-5
1.4.2.11 Ready	1-13	3.1.7 Servo Power Amplifier	3-5
1.4.2.12 On Line.....	1-13	3.1.8 Operator Control Panel	3-5
1.4.2.13 Rewinding	1-13	3.1.9 Interconnect Board	3-5
1.4.2.14 File Protect.....	1-14	3.1.10 Position Sensors Board.....	3-5
1.4.2.15 Load Point.....	1-14	3.1.11 Power Supplies.....	3-5
1.4.2.16 End of Tape.....	1-14		
1.4.2.17 Density	1-14		
1.4.2.18 Speed.....	1-14		
1.4.3 Command Execution.....	1-15		
1.4.3.1 Read Forward.....	1-15		
1.4.3.2 Read Reverse	1-16		
1.4.3.3 Write.....	1-16		
1.4.3.4 Read Reverse Edit.....	1-16		
1.4.3.5 Write Edit.....	1-16		

SECTION IV - DIAGNOSTICS	Page
4.0 General	4-1
4.1 Controls and Indicators	4-1
4.2 Troubleshooting	4-1
4.2.1 Accessing for Troubleshooting	4-1
4.3 Power Up	4-2
4.3.1 Drive Electronics Failure Displays	4-2
4.3.2 Formatter Failure Codes	4-4
4.3.3 Formatter Power Up Self-Tests	4-5
4.4 Loading Failure Codes	4-6
4.5 Front Panel Diagnostics	4-8
4.5.1 Diagnostics Menu	4-8
4.5.2 Operating Procedure	4-10
4.5.2.1 Entering Diagnostics Mode	4-10
4.5.2.2 Self-Test	4-10
4.5.2.2.1 Power Up Self-Test	4-11
4.5.2.2.2 Data Test	4-11
4.5.2.3 Connector or Cable Failures	4-14
4.5.2.4 Motion Diagnostic Tests	4-15
4.5.2.5 Drive Adjustment Tests	4-16
4.5.2.6 Set Up	4-17
4.5.2.7 Calibration	4-19
4.5.2.8 Data Diagnostics	4-20

SECTION V - MAINTENANCE

5.0 General	5-1
5.1 Preventive Maintenance	5-1
5.1.1 Daily Inspection	5-1
5.1.2 Cleaning	5-1
5.1.2.1 Tape Reels	5-1
5.1.2.2 Erase/Write/Read Head Cleaning	5-1
5.1.2.3 Tape Path Cleaning	5-2
5.1.3 Routine Adjustments	5-2
5.1.4 Lubrication	5-2
5.1.5 Head Wear	5-2
5.2 Corrective Maintenance	5-2
5.2.1 Tools and Test Equipment	5-3
5.2.2 Accessing the Drive	5-3
5.2.3 Troubleshooting	5-3
5.2.3.1 Accessing the Drive	5-4
5.2.3.2 Safety Interlocks	5-4
5.3 Parts Replacement	5-4
5.3.1 PCBAs In Card Cage	5-4
5.3.2 Drive Electronics Board	5-5
5.3.3 Interconnect PCBA	5-5
5.3.4 Hub Lock Solenoid	5-5
5.3.5 Read Preamplifier	5-6
5.3.6 Fan	5-6
5.3.7 Take-up Reel Assembly	5-7
5.3.8 Take-up Arm Assembly	5-8
5.3.9 Supply Arm Assembly	5-8
5.3.10 Retract and Pivot Sensors	5-9
5.3.11 Mother Board PCBA	5-10
5.3.12 Operator Control Panel PCBA	5-11
5.3.13 EMI Filter	5-11
5.3.14 Reel-In-Place Sensor Assy	5-12
5.3.15 File-Protect Sensor Assembly	5-13
5.3.16 Supply Arm Limit Sensor	5-13
5.3.17 Take-up Arm Limit Sensor	5-14

Section	Page
5.3.18 12-VDC Regulator Assembly	5-14
5.3.19 5-VDC Regulator Power Supply	5-15
5.3.20 Servo Amplifier Assembly	5-16
5.3.21 Blower Assembly	5-17
5.3.22 Panel Assembly	5-18
5.3.23 Supply Hub Assembly	5-18
5.3.24 Flux Gate	5-19
5.3.25 Capstan	5-19
5.3.26 Capstan Motor	5-20
5.3.27 Capstan Motor Assembly	5-20
5.3.28 BOT/EOT Sensor Assembly	5-22
5.3.29 Tape-In-Chan Emit./Sensor Assy	5-23
5.3.30 Vacuum Motor Assembly	5-23
5.3.31 Supply Reel Motor Assembly	5-25
5.3.32 Take-up Reel Motor Assembly	5-25
5.3.33 Magnetic Head Assembly	5-26
5.3.34 Tape Guide Replacement	5-27
5.4 Adjustments	5-27
5.4.1 Preliminary Checkout	5-27
5.4.2 Buffer Arms Adjustment	5-28
5.4.2.1 Rollers Height Adjustment	5-28
5.4.2.2 Capacitive Disk Height Adjust	5-29
5.4.2.3 Buffer Arm Calibration	5-30
5.4.2.3.1 Sand Cast Deck	5-30
5.4.2.3.2 Die Cast Deck	5-31
5.4.2.4 Static Arm Tension Cal	5-33
5.4.2.5 Capstan Check	5-34
5.4.2.6 Load Test	5-34
5.4.2.7 Diagnostic With Tape Loaded	5-35
5.4.2.8 Calibration, Mechanical	5-35
5.4.2.9 Calibration/Set Up, Electronic	5-36
5.4.2.9.1 Drive Electronic Set Up	5-37
5.4.2.9.2 Calibration, Electronic	5-39
5.5 Diagnostics	5-43
5.5.1 General	5-43
5.5.2 Motion Diagnostics	5-43
5.5.3 Drive Adjust	5-44

SECTION VI - PARTS IDENTIFICATION

6.0 Introduction	6-1
6.1 Parts Warranty	6-1
6.2 Out of Warranty Emergency Parts	6-1
6.3 Parts Ordering Information	6-1
6.3.1 Minimum Parts Orders	6-1
6.3.2 Returning Parts to Kennedy	6-2
6.3.3 Parts Order Leadtime	6-2
6.3.4 Customer Service Addresses	6-2

SECTION VII - WIRING/SCHEMATIC DIAGRAMS

7.0 General	7-1
7.1 Components	7-1
7.2 Logic Conventions and Symbols	7-1
7.2.1 TTL Logic	7-1
7.2.2 Logic Symbology	7-2
7.3 Schematic Flow	7-2
7.4 Terminals	7-2
7.5 List of Schematics	7-2
7.6 System Signal Distribution	7-3

APPENDIX A - GLOSSARY..... A1-A3

LIST OF ILLUSTRATIONS

<u>Figure</u>	<u>Page</u>
1-1	Model 9600B/9650B Auto-Load Drive.. 1-1
1-2	Receiver/Driver Interface Config..... 1-5
1-3	Daisy Chaining.....1-6
1-4	NRZI Write Data..... 1-18
1-5	PE Write Data..... 1-19
1-6	DDPE Write Data..... 1-20
1-7	NRZI Read Forward..... 1-21
1-8	PE Read Forward..... 1-22
1-9	DDPE Read Forward..... 1-23
1-10	NRZI Write File Mark..... 1-24
1-11	PE Write File Mark..... 1-25
1-12	DDPE Write File Mark..... 1-26
1-13	NRZI Read File Mark..... 1-27
1-14	PE Read File Mark..... 1-28
1-15	DDPE Read File Mark..... 1-29
2-1	Shipping Retainer Bracket.....2-2
2-2	Dust Cover Support Bar.....2-2
2-3	Grounding Cable Clamp Details.....2-2
2-4	Card Cage, Cables, And Terminators...2-3
2-5	Daisy Chaining.....2-4
2-6	Outline And Installation Dwg (9600B)...2-6
2-7	Outline And Installation Dwg (9650B)...2-7
2-7A	Deck Assembly Support Bar.....2-8
2-8	Track Subassembly.....2-8
2-9	Power-In Assembly.....2-9
2-10	Panel Controls And Indicators..... 2-14
2-11	Installing Supply Reel..... 2-15
2-12	Tape Threading..... 2-18
3-1	9600B/9650B General Block Diagram3-2
4-1	Diagnostics Menu Dynamics.....4-8
5-1	Erase/Write/Read Head Cleaning.....5-1
5-2	Tape Path Cleaning.....5-2
5-3	Card Cage.....5-4
5-4	Hub Lock Solenoid.....5-5
5-5	Fan.....5-6
5-6	Take-up Reel Assembly.....5-7
5-7	Take-up and Supply Arm Assemblies5-8
5-8	Retract and Pivot Sensor Assy.....5-9
5-9	Mother Board PCBA..... 5-10
5-10	Operator Control Panel PCBA..... 5-11
5-11	File-Protect and Reel-In-Place Sensor Assemblies..... 5-12
5-12	Supply Arm Limit Sensor..... 5-13
5-13	Take-up Arm Limit Sensor..... 5-14
5-14	12-VDC Regulator Power Supply..... 5-14
5-15	5-VDC Regulator Power Supply..... 5-15
5-16	Servo Amplifier Assembly..... 5-16
5-17	Blower Assembly..... 5-17
5-18	Panel Assembly..... 5-18
5-19	Supply Hub Assembly..... 5-18
5-20	Flux Gate Removal..... 5-19
5-21	Capstan Removal..... 5-19
5-22	Capstan Motor Assembly..... 5-20
5-23	EOT/BOT Sensor Assembly..... 5-22
5-24	Tape-In-Channel Emitter and Sensor... 5-23
5-25	Vacuum Motor Assembly..... 5-24

Figure

Page

5-26	Supply Reel Motor Assembly..... 5-25
5-27	Magnetic Head Assembly and Read Preamplifier..... 5-26
5-28	Tape Guide Alignment..... 5-27
5-29	Roller Height Adjustment..... 5-29
5-30	Buffer Arms Calibration..... 5-33
5-31	Calibration and Diagnostics Jumpers Location..... 5-37
5-32	Tracking..... 5-43
6-1	Front Panel Assembly..... 6-3
6-2	Deck Assembly (Top)..... 6-4
6-3	Deck Assembly (Bottom)..... 6-6
6-4	Chassis Assembly..... 6-7
6-5	Card Cage PCBAs..... 6-8
A-1	Velocity Profiles..... A-3

LIST OF TABLES

Table

Page

1-1	Operational Specifications..... 1-2
1-2	Tape Reel Capacities..... 1-4
1-3	Physical/Environmental Specifications 1-4
1-4A	Drive Address Summary, P-2..... 1-7
1-4B	Drive Address Summary, P-1..... 1-8
1-5	Command Configurations..... 1-15
2-1	Motion Control Sequence..... 2-12
4-1	Drive Electronics Failure Displays..... 4-2
4-2	Power Up Failure Codes..... 4-4
4-3	Loading Failures..... 4-6
4-4	Diagnostics Menu Structure..... 4-9
4-5	Data Test Failure Codes..... 4-13
4-6	Cable or Connector Faults..... 4-14
4-7	PCBAs in Card Cage..... 4-14
4-8	Motion Test Definitions..... 4-15
5-1	Tools and Test Equipment Required 5-3
6-1	Recommended Spare Parts (Field)..... 6-9
6-2	Recommended Spare Parts (Depot)..... 6-9
6-3	Recommended Maintenance Tools..... 6-10

SECTION I
DESCRIPTION/APPLICATION

SECTION I
GENERAL DESCRIPTION AND APPLICATION DATA

1.1 GENERAL DESCRIPTION

The Kennedy Model 9600B/9650B Tape Drive (Figure 1-1) is rack mountable (9600B) and desk-top (9650B) automatic load, tape drive that includes an embedded Formatter capable of communicating between an industry standard interface bus and ANSI-compatible PE 1600 and 3200 CPI, NRZI 800 CPI tapes. The drive can operate in Streaming Mode at 100 ips or Start/Stop Mode at 50 ips, and can read in either forward or reverse direction in all densities.

1.1.1 HOST INTERFACE

The 9600B/9650B Drive has Industry Standard Interface for Formatted 1/2-inch Tape Drives.

1.1.2 MICROCOMPUTER BASED DESIGN

The 9600B/9650B uses two microprocessors; one in the Formatter, and one in the Drive Control Electronics.

1.1.3 DIAGNOSTICS AND FAULT ISOLATION

The 9600B/9650B includes built-in diagnostics with front-panel eight-character LED readout.

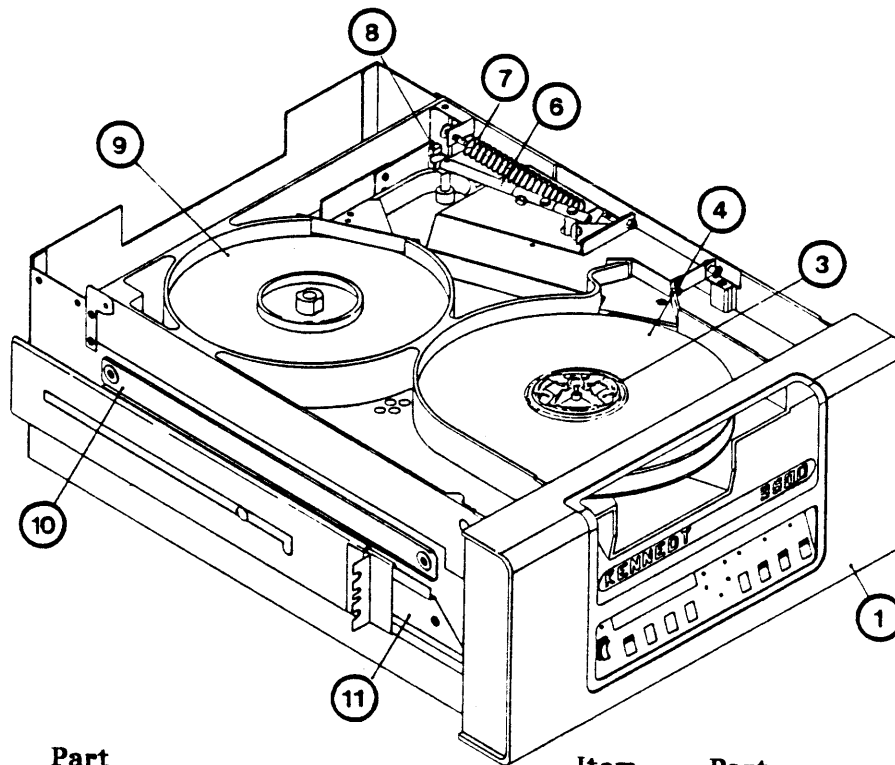

<u>Item</u>	<u>Part</u>
1	Panel Assembly
2	Supply Arm Assy (bottom, hidden)
3	Supply Hub Assembly
4	Supply Reel Tape
5	Magnetic Head Assembly (hidden)
6	Take-up Arm Assembly (top)

<u>Item</u>	<u>Part</u>
7	Spring, Extension
8	Take-up Arm Limit Sensor PCBA
9	Vacuum Hub Assembly
10	Support Bar
11	Slide Set

Figure 1-1. Model 9600B/9650B Auto-load Tape Drive

1.2 SPECIFICATIONS

1.2.1 OPERATIONAL SPECIFICATIONS

NOTE: See Appendix A for parameter definitions.

Table 1-1. Operational Specifications

TAPE					
Width	0.498 (+/-0.002) inch				
Thickness	1.9 or 1.3 mil (0.038 or 0.0226mm)				
Tension	8.75 +/-0.5 ounces				
Reel Size (Open Reels - inches)	6.0	7.0	8.5	10.5	Thickness
Tape Length (feet)	200	600	1200	2400	1.9 mil
				3600	1.3 mil
Reel Capacity	(See Table 1-2)				
PERFORMANCE					
Recording Densities:			Tape Speed:		
NRZI	800 CPI		Start/Stop	50 ips	
PE	1600 CPI		Streaming	100 ips	
DDPE	3200 CPI		Rewind, nominal	200 ips	
Gap Length	NRZI/PE 0.6 inch (nominal - Read/Write)				
Data Access Time (nominal):					
			<u>Time</u>		
<u>Operation</u>	<u>Density</u>		<u>50 IPS</u>	<u>100 IPS</u>	
Read	800/1600/3200		12.4 ms	20.6 ms	
Write	800/1600/3200		8.6 ms	19.1 ms	
Command Reconstruct Time (with Autospeed Disabled):					
			<u>Time</u>		
<u>Operation</u>	<u>Density</u>		<u>50 IPS</u>	<u>100 IPS</u>	
Read	800/1600/3200		0.7 ms	4.2 ms	
Write	800/1600/3200		0.7 ms	3.8 ms	
Maximum Latency for Reinstruction on Ramp:					
<u>Operation</u>	<u>Density</u>		<u>Speed</u>	<u>Time</u>	
Read	800/1600/3200		50 IPS	3.2 ms	
Write	800/1600/3200		50 IPS	3.2 ms	

Table 1-1. Operational Specifications (Continued)

Reinstruct Time Limits for Auto Speed Transition to 100 IPS:			
<u>Operation</u>	<u>Density</u>	<u>Time</u>	
Read	800/1600/3200	2.8 ms	
Write	800/1600/3200	2.4 ms	
Reposition Time, Streaming Mode (100 IPS):			
<u>Operation</u>	<u>Density</u>	<u>Time</u>	
Read	800/1600/3200	42.5 ms	
Write	800/1600/3200	42.5 ms	
Data Transfer Rate:			
<u>Speed</u>	<u>Density (CPI)</u>	<u>Rate (KB/SEC)</u>	
		<u>Normal</u>	<u>Maximum</u>
50 ips	NRZI 800	40	48
	PE 1600	80	96
	DDPE 3200	160	192
100 ips	NRZI 800	80	96
	PE 1600	160	192
	DDPE 3200	320	384
<hr/>			
POWER REQUIREMENTS			
<hr/>			
AC Units:			
Input Voltage	100, 120, 220, 240 VAC +15% -10%		
	50 or 60 Hz +/-2 Hz		
Input Current	<u>120 VAC</u>	<u>220 VAC</u>	
	3.0 amps	1.5 amps	
Power: Nominal	300 watts	300 watts	
	Peak	400 watts	400 watts
Fuse	6 amp at 110/120	3 amp at 220/240 VAC (Slo-Blo)	
Heat Dissipation	1025 BTU/hr		
DC Units:			
Input Voltage	48, 60VDC +20% -10%		
Input Current	<u>48 VDC</u>	<u>60 VDC</u>	
	7.5 amps	5.5 amps	
Power: Nominal	350 watts	350 watts	
	Peak	450 watts	450 watts
Fuse	12 amp	10 amp	
Heat Dissipation	1194 BTU/hr		

Table 1-2. Tape Reel Capacities

Reel Size (inches)	Tape Thickness				Blocks (Bytes)	
	1.9 mil		1.3 mil			
	6	7	8.5	10.5	10.5	
NRZI (MBytes)	1	3	6	10	15	512
	1.5	5	9	17	25	2K
	1.8	5.5	11	21	32	8K
	2	6	12	23	34	64K
PE (MBytes)	1.3	4	8	15	22	512
	2.5	8	15	30	45	2K
	3.5	11	21	41	62	8K
	4	12	23	45	68	64K
DDPE (MBytes)	2.5	8	15	30	44	512
	5	15	30	60	90	2K
	7	21	41	82	120	8K
	8	23	45	90	134	64K

1.2.2 PHYSICAL/ENVIRONMENTAL SPECIFICATIONS (Table 1-3)

Table 1-3. Physical/Environmental Specifications

PHYSICAL SPECIFICATIONS		
Dimensions:		
Height	8.75 inches (22.23 cm)	
Width	17.00 inches (43.18 cm)	
Depth: From Mounting Surface	2.00 inches (5.08 cm)	
Depth: Overall	24.50 inches (62.23 cm)	
Mounting:	Slide Mount in standard 19-inch RETMA Rack	
Weight:	9600B (with Slides)	9650B
No Packing Material	110 lbs (49.5 Kgm)	122 lbs. (54.9 Kgm)
With Packing Material	135 lbs (60.75 Kgm)	152 lbs (68.4 Kgm)
ENVIRONMENTAL SPECIFICATIONS		
Temperature operating	60° to 90° F (15.6° to 32.2° C)	
Temperature, non-operating	-40° to +122° F (-40° to +50° C)	
Humidity, (with wet bulb)	Operating (+78° max) Storage (+83° max) 20 to 80% 5 to 90%	
Altitude, operating	-1300 to 10,000 ft. (-400 to 3000 meters)	
Altitude, shipping	-1300 to 50,000 ft. (-400 to 15000 meters)	

1.3. INTERFACE SPECIFICATION

1.3.1 GENERAL

This section describes the signal requirements and characteristics of the interface between the tape drive and the controller. The connectors and cable requirements are described, as well as the actual lines and the commands derived from the lines. The interface lines are summarized in Tables 1-4A and 1-4B while the command structure is summarized in Table 1-5.

1.3.2 INTERFACE CONNECTORS

The interface connectors on the Model 9600B/9650B are designed for standard fifty line shielded cables. For each active connector pin there is an associated ground pin. The mating interface connectors are two 50-pin card edge connectors.

1.3.3 INTERFACE SIGNAL CHARACTERISTICS

Signals from the controller to the Model 9600B/9650B must conform to the following specifications:

Levels: 1 = Low = True = 0V (+0.7 Vdc)
 0 = High = False = +3V (+/-0.5 Vdc)

Pulses: 1 = Low = True = 0V (+0.7 Vdc)
 0 = High = False = +3V (+/-0.5 Vdc)

NOTE:

Total edge transmission
 Delay = <200 nanosec over
 a 20 ft cable (6 meters).

All output signals from the Model 9600B/9650B are driven by open collector type line drivers capable of sinking up to 36 mA (25 standard unit loads) in the low true state. Open lines will result in false signal levels.

1.3.4 INTERFACE CABLES

Per FCC and ESD specs, interface cables should be braided and shielded with maximum allowable length of 20 feet.

1.3.5 RECEIVER/DRIVER CONFIGURATION AND TERMINATION

The input lines to the transport are terminated with a 220 ohm resistor to plus five volts, and a 330 ohm resistor to ground (Figure 1-2). All input circuits have low level input voltage of 0.7 V maximum and a high level input voltage of 2.0 V minimum. The input receivers are all 74LS type circuits.

All output lines must be terminated at the far end of the daisy chained cable with a 220 ohm resistor to plus five volts and a 330 ohm resistor to ground. Output circuits are 7438 open collector drivers as shown in Figure 1-2.

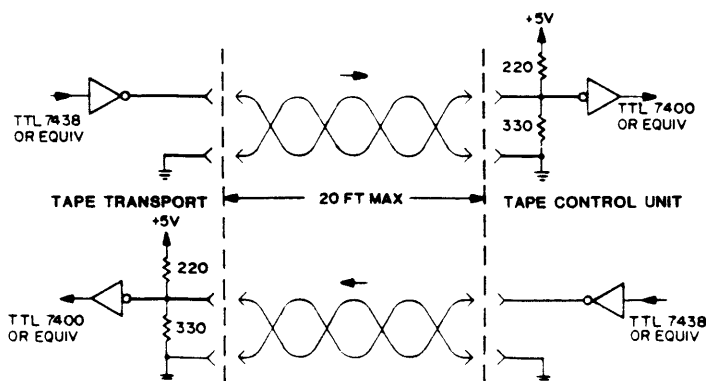

Figure 1-2. Receiver/Driver Interface Configuration

1.3.6 DAISY CHAINING

The 9600B/9650B transport may be configured to allow operation of up to eight transports with a single controller as shown in Figure 1-3.

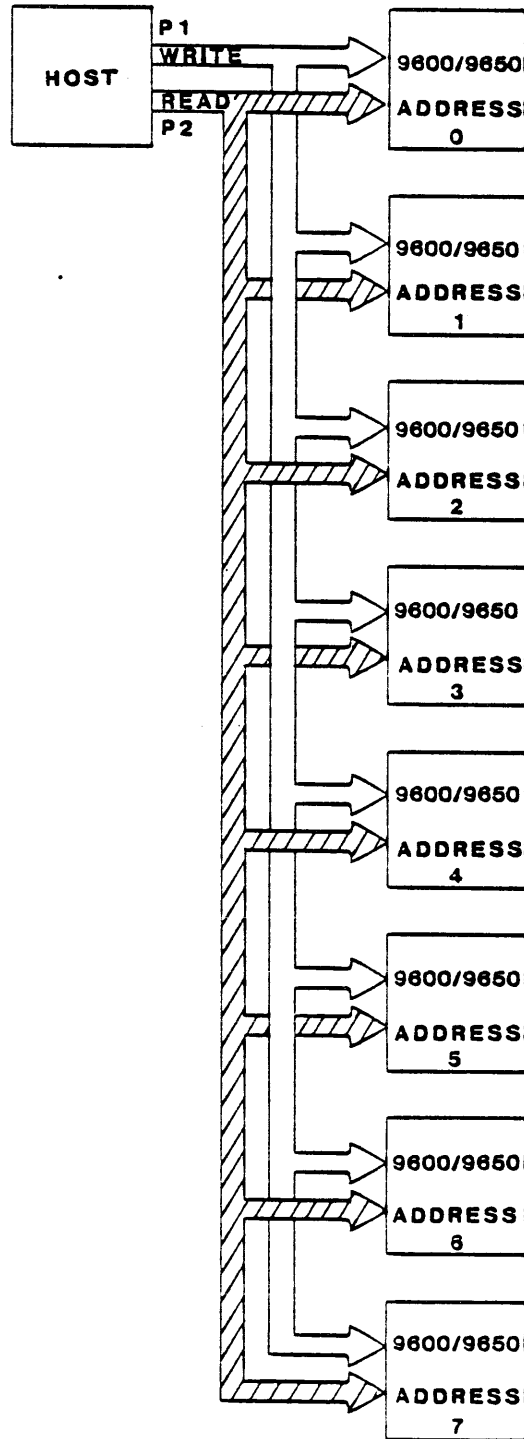

Figure 1-3. Daisy Chaining

1.4 INTERFACE INPUT AND OUTPUT SIGNALS

The following sections tabulate and describe Host/Drive interface signals. Input Signals (IN) are Signals from the Host; Output Signals (OUT) are Signals to the Host. Tables 1-4A and 1-4B list Host-to-Drive I/O Signals. Connector Signal/Pin assignments include Signal and Ground Pins and related Signal Mnemonic.

Table 1-4A. Drive Interface Summary, Connector P-2

Pin Sig/Grd	Mnemonic	Signal Name	In/Out
P2-1/5	RP	Read Data P	Out
P2-2/5	R0	Read Data 0	Out
P2-3/5	R1	Read Data 1	Out
P2-4/5	LDP	Load Point	Out
P2-6/5	R4	Read Data 4	Out
P2-8/7	R7	Read Data 7	Out
P2-10/9	R6	Read Data 6	Out
P2-12/11	HER	Hard Error	Out
P2-14/13	FMK	File Mark	Out
P2-16/15	ID/CCG	ID Burst/Check Char Gate	Out
P2-18/17	FEN	Formatter Enable	In
P2-20/19	R5	Read Data 5	Out
P2-22/21	EOT	End of Tape	Out
P2-24/23	OFL	Off Line	In
P2-26/25	DEN1	Density 1	Out
P2-28/27	RDY	Ready	Out
P2-30/29	RWG	Rewinding	Out
P2-32/31	FPT	File Protect	Out
P2-34/33	RSTR	Read Strobe	Out
P2-36/35	WSTR	Write Strobe	Out
P2-38/37	DBY	Data Busy	Out
P2-40/39	SPD	Speed	Out
P2-42/41	CER	Corrected Error	Out
P2-44/43	ONL	On Line	Out
P2-46/45	TAD1	Transport Address 1	In
P2-48/47	FAD	Formatter Address	In
P2-50/49	HSP	High Speed	In

Table 1-4B. Drive Interface Summary, Connector P1

Pin Sig/Grd	Mnemonic	Signal Name	In/Out
P1-2/1	FBY	Formatter Busy	Out
P1-4/3	LWD	Last Word	In
P1-6/5	W4	Write Data 4	In
P1-8/7	GO	Initiate Command	In
P1-10/9	W0	Write Data 0	In
P1-12/11	W1	Write Data 1	In
P1-14/13	DEN0	Density 0	Out
P1-16/15	LOL	Load On Line	In
P1-18/17	REV	Reverse/Forward	In
P1-20/19	REW	Rewind	In
P1-22/21	WP	Write Data P	In
P1-24/23	W7	Write Data 7	In
P1-26/25	W3	Write Data 3	In
P1-28/27	W6	Write Data 6	In
P1-30/29	W2	Write Data 2	In
P1-32/31	W5	Write Data 5	In
P1-34/33	WRT	Write/Read	In
P1-36/35	LGP	Long Gap	In
P1-38/37	EDT	Edit	In
P1-40/39	ERS	Erase	In
P1-42/41	WFM	Write File Mark	In
P1-44/43	Reserved		
P1-46/45	TAD0	Transport Address 0	In
P1-48/47	R2	Read Data 2	Out
P1-50/49	R3	Read Data 3	Out

1.4.1 INTERFACE INPUT SIGNALS (from Host to Drive)

1.4.1.1 TRANSPORT ADDRESS, FORMATTER ADDRESS

TAD0, TAD1, FAD Level P2-48, P1-46, P2-46

The states of these lines determine which of up to eight tape drives are selected by the controller. The following list defines the tape drives addresses produced as a result of the various TAD0, TAD1, FAD.

<u>FAD</u>	<u>TAD0</u>	<u>TAD1</u>	<u>ADDRESS</u>
0	0	0	SLT0
0	0	1	SLT1
0	1	0	SLT2
0	1	1	SLT3
1	0	0	SLT4
1	0	1	SLT5
1	1	0	SLT6
1	1	1	SLT7

1.4.1.2 INITIATE COMMAND - GO

GO	Pulse	P1-3
----	-------	------

A pulse which initiates any command specified by the command lines described in the following paragraphs. Information on the command lines is copied into the unit on the trailing edge of the GO pulse. At the end of the reinstruct window in streaming write commands only, it is possible for the Host to extend the reinstruct window by asserting and holding the GO pulse in a true state. The unit will continue to stream for up to one inch waiting for the trailing edge of the GO pulse as the Host returns GO to the false state. If one inch is exceeded and the GO pulse has yet to be denied, the unit shall enter a reposition cycle. This feature in effect creates extended gaps.

1.4.1.3 REVERSE

REV	Level	P1-18
-----	-------	-------

Command line refer to Table 1-5.

1.4.1.4 WRITE

WRT	Level	P1-34
-----	-------	-------

Command line refer to Table 1-5.

1.4.1.5 WRITE FILE MARK

WFM	Level	P1-42
-----	-------	-------

Command line refer to Table 1-5.

1.4.1.6 EDIT

EDT	Level	P1-38
-----	-------	-------

Command line refer to Table 1-5.

1.4.1.7 ERASE

ERS	Level	P1-40
-----	-------	-------

Command line refer to Table 1-5.

1.4.1.8 HIGH SPEED

HSP	Level	P2-50
-----	-------	-------

When true, this signal causes the selected on-line unit to operate in the high speed mode (100 ips).

1.4.1.9 LONG GAP

LGP Level P1-36

When true during a Write Mode, this level causes the generation of a longer Interrecord Gap (erased area on tape) (selected in the Set Up Options - Section IV) to allow ample reformat periods as required for Host system latencies. Long Gap Time is limited by its setting in Set Up Options, but terminates automatically if a Write Command is received before the selected limit.

1.4.1.10 REWIND

REW Pulse P1-20

A pulse which causes the selected transport to rewind to load point. This pulse does not cause the formatter to go busy. The Ready status will remain false during rewind. In daisy chained systems, the rewind pulse can be issued to one or more of the units in the chain while allowing data transfer operations to occur on any other unit in the chain.

1.4.1.11 OFF LINE/UNLOAD

OFL Pulse P2-24

This pulse causes the transport to go off line immediately, then rewind to load point and unload the tape.

1.4.1.12 LAST WORD

LWD Level P1-4

When this level is true during a write or variable erase command, it indicates that the next character to be strobed into the formatter is the last character of the record. LWD should go true when the last data character is placed on the interface lines.

1.4.1.13 FORMATTER ENABLE

FEN Level P2-18

When false this level causes all units in a daisy chain configuration to revert to the quiescent state. This line may be used to disable the units if controller power is lost or to clear unit logic when illegal commands or unusual conditions occur. When denied during command execution, the unit will abort the command in an orderly fashion and stop motion. The unit Set Up Options (Section IV) allows the polarity of this level to be selected.

1.4.1.14 WRITE DATA LINES

WP, W0-W7 Level

These 9 lines transmit write data from the controller to the formatter. The 8 data bits appearing on W0-W7 are written onto the corresponding channels on tape; W7 corresponds to the least significant bit of the character. Line WP is optional and is utilized only if it is required to check the parity bit generated by the customer. The formatter generates odd parity internally on the basis of data contained on W0-W7.

NOTE: The HER may be reported as a real time pulse for each error condition as it occurs; or the occurrence of at least one HER or CER within the block can be captured by the Host before the falling edge of DBY at the end of the data block.

- a. Longitudinal parity error.
- b. Improper record format.
- c. CRCC parity error.
- d. Vertical parity error on a data character.
- e. Host write parity error (optional).
- f. No file mark detected in Read After Write mode when executing a Write File Mark command.
- g. If a gap of 25 feet is detected while executing a Read Block, Space Block or Search File Mark command (optional).
- h. Read after Write compare error.
- i. Excessive skew.
- j. Postamble error.
- k. Multiple channel error.
- l. CRC error.

1.4.2.4 CORRECTED ERROR (PE, DDPE MODE)

CER	Pulse	P2-42
-----	-------	-------

This pulse indicates that a single track dropout has been detected during read or write and the unit will perform a vertical parity correction.

1.4.2.5 CHECK CHARACTER GATE (NRZI MODE ONLY)

ID/CCG	Level	P2-16
--------	-------	-------

This level is set true by the unit when the read information being transmitted to the controller is the cyclic redundancy check character (CRCC) or the longitudinal redundancy check character (LRCC) of the data block. When data characters are transmitted, CCG goes false. Data and Check information can be distinguished by gating Read Strobe with CCG or its inverse. After leaving load point this line should only be used during NRZI mode.

NOTE: CCG and the Read Strobes (RSTR) for the check characters can be disabled as one of the Set Up Options (Section IV).

1.4.2.6 IDENTIFICATION BURST (PE, DDPE MODE)

ID/CCG	Level	P2-16
--------	-------	-------

The level identifies that an ID burst is being detected for PE or DDPE.

1.4.2.7 FILE MARK

FMK	Pulse	P2-14
-----	-------	-------

File mark is pulsed when a file mark is detected on the tape during a read operation or during a write file mark operation. The FMK line will be pulsed after a complete file mark has been read. When reading NRZI file marks, read strobes are issued to the interface.

1.4.2.8 WRITE STROBE

WSTR Pulse P2-36

This line pulses each time a data character is written onto tape. WSTR samples the write data lines WP, W0-W7 from the Host and copies this information character by character into the unit's write logic. The first character should be available prior to the first write strobe pulse and succeeding characters should be set up within half a character period after the trailing edge of each write strobe pulse. The write strobe is also active during variable length erase command; however, no data will be written to tape.

1.4.2.9 READ STROBE

RSTR Pulse P2-34

This line consists of a pulse for each character of read information allowing the transmission of data to the host. This signal should be used to sample the read data lines RP, R0-R7.

In a NRZI Read operation the transmission of CRC and LRC data characters will be flagged by the check character gate (CCG) signal as described previously under Check Character Gate.

1.4.2.10 READ DATA LINES

RP, R0-R7 Levels

These lines transmit the read data for all three densities. Each character read from tape is made available by parallel sampling the read lines using the Read Strobe. The data remains on the read lines for a full character period.

1.4.2.11 READY

RDY Level P2-28

RDY is true (low) only when the transport is ready to receive external commands; the following conditions must exist:

- a. All interlocks are made.
- b. Initial load or rewind sequence is complete.
- c. Transport is on-line.
- d. Transport is not rewinding.

1.4.2.12 ON LINE

ONL Level P2-44

When ONL is true (low), the transport is under host or remote control. ONL false (high) indicates the transport is under local control.

1.4.2.13 REWINDING

RWG Level P2-30

RWG is true (low) when the transport is engaged in a rewind operation or returning to the load point at the end of the rewind operation.

PROTECT

Level

P2-32

true (low) when a reel of tape without a write-enable ring is mounted on the transport hub.

1.4.2.15 LOAD POINT

LDP

Level

P2-4

LDP is true (low) when the load point marker is under the BOT sensor and the transport is not rewinding. After receipt of a motion command the signal will remain true until the load point marker leaves the BOT sensor area.

1.4.2.16 END OF TAPE

EOT

Level

P2-22

EOT is true (low) when the EOT marker is detected in the forward direction. EOT goes false (high) when the EOT marker is detected in reverse (REWIND).

1.4.2.17 DENSITY

DEN0, DEN1

Level

P1-14, P2-26

Binary-coded signals that indicate the current density of the Drive. Two coding schemes are available. These schemes are:

<u>DENSITY</u>	<u>DENS OUT NRZ ONLY</u>		<u>DENS OUT CODED</u>	
	<u>DEN 1</u>	<u>DEN 0</u>	<u>DEN 1</u>	<u>DEN 0</u>
800	1	0	1	1
1600	0	0	0	1
3200	0	0	1	0

The coding scheme used can be selected as one of the Set Up Options (Section IV).

1.4.2.18 SPEED

SPD

Level

P2-40

SPD true (low) indicates the selected transport is in the high speed (100 ips) streaming mode. A false level indicates low speed (50 ips).

1.4.3 COMMAND EXECUTION

The following section describes the appropriate combinations of signal lines required to achieve Command Execution followed by a description of the responses of the Model 9600B/9650B. Command configuration for the Model 9600B/9650B is shown in Table 1-5. Write and read interface timing diagrams for each density at the two tape speeds are shown in Figures 1-4 through 1-15.

Table 1-5. Command Configuration

COMMAND	REV	WRT	WFM	EDT	ERS
READ FORWARD	0	0	0	0	0
READ REVERSE	1	0	0	0	0
READ REVERSE EDIT	1	0	0	1	0
WRITE	0	1	0	0	0
WRITE EDIT	0	1	0	1	0
WRITE FILE MARK	0	1	1	0	0
ERASE VARIABLE LENGTH	0	1	0	0	1
ERASE FIXED LENGTH	0	1	1	0	1
DATA SECURITY ERASE	0	1	1	1	1
SPACE FORWARD	0	0	0	0	1
SPACE REVERSE	1	0	0	0	1
FILE SEARCH FORWARD	0	0	1	0	0
FILE SEARCH REVERSE	1	0	1	0	0
FILE SEARCH FORWARD (IGNORE DATA)	0	0	1	0	1
FILE SEARCH REVERSE (IGNORE DATA)	1	0	1	0	1
SELECT 800 CPI	0	1	1	1	0
SELECT 1600 CPI	0	0	1	1	1
SELECT 3200 CPI	1	0	1	1	1

1.4.3.1 READ FORWARD

On receipt of the Read Forward command loaded into the unit with the GO pulse, the FBY signal goes true and the unit begins to accelerate the tape up to nominal velocity. When the tape is up to speed and the data block to be read is detected, DBY shall go true. Read Strokes (RSTR) accompany the decoded data. DBY will go false after the complete block has been read indicating readiness of the unit to accept a new command. If no command is received, the unit will either stop in the gap in 50 ips operation or enter a reposition operation in 100 ips operation and FBY will go false.

1.4.3.2 READ REVERSE

This command is similar to a read forward command except that the tape motion is in the reverse direction.

1.4.3.3 WRITE

On receipt of the Write command loaded into the unit with the GO pulse, the FBY signal goes true and the unit begins to accelerate the tape up to nominal velocity. When the tape is up to speed and the data block is ready to be written, DBY shall go true. Write Strokes (WSTR) are transmitted to the Host by the unit and the Host presents each data byte to be written. When LWD is received by the unit from the Host, the unit will finish reading the block, error status shall be made available to the Host and then the unit shall force DBY false indicating the end of the block just written. FBY will remain true if a new command in the same direction is received within the command re-instruct period. If no command is received, the unit will either stop in the gap in 50 ips operation or enter a reposition operation in all 100 ips write operation and FBY will go false.

1.4.3.4 READ REVERSE EDIT

The Read Reverse Edit command besides providing data establishes the correct position of the tape relative to the magnetic head prior to the Host executing a Write Edit command.

1.4.3.5 WRITE EDIT

The Write Edit command must be preceded by a Read Reverse Edit command. The Write Edit command allows a block of the same length to be written over an already existing data block on the tape.

1.4.3.6 WRITE FILE MARK

This command invokes the writing of a file mark in the density selected.

1.4.3.7 FIXED LENGTH ERASE

This command invokes a 3.5 inch length of tape to be erased. This command is always executed in the forward direction of tape motion.

1.4.3.8 DATA SECURITY ERASE

This command invokes tape to be erased from the present tape position to a point 3 feet past End of Tape.

1.4.3.9 SPACE FORWARD AND SPACE REVERSE

These commands are similar to a Read Forward or Read Reverse command, except that no read strobes are returned to the Host and no error checking is performed. However, the unit will check and report if the record is a file mark.

1.4.3.10 FILE MARK SEARCH FORWARD/REVERSE

A file mark search forward command causes the unit to execute a series of read forward commands, and the reverse command, a series of read reverse commands searching for a file mark. Forward or reverse search is terminated by the presence of a file mark, 25 feet of blank tape, or BOT in reverse search. In the EOT region a gap of 5 feet results in a search termination. If the first block encountered is not a file mark and the command was issued at 50 ips, the unit will jump to 100 ips if autospeed is a selected option.

1.4.3.11 ERASE VARIABLE

This command causes the unit to execute a dummy write, erasing tape until Last Word (LWD) is issued by the Host. WSTR's are transmitted to the Host during the execution of this command.

1.4.3.12 DENSITY SELECT

The Density Select Command forces the unit to **write** tapes in the density specified. This Command is effective only when the unit is online, selected, the tape is at BOT, and the unit has been placed in a remote density mode (the remote density LED is ON). However, if the unit performs a **read** from BOT of the tape, the unit will automatically read tape at the density of the tape.

1.5 HOST INTERFACE TIMING

The following Figures 1-4 thru 1-15 illustrate Host Interface Timing.

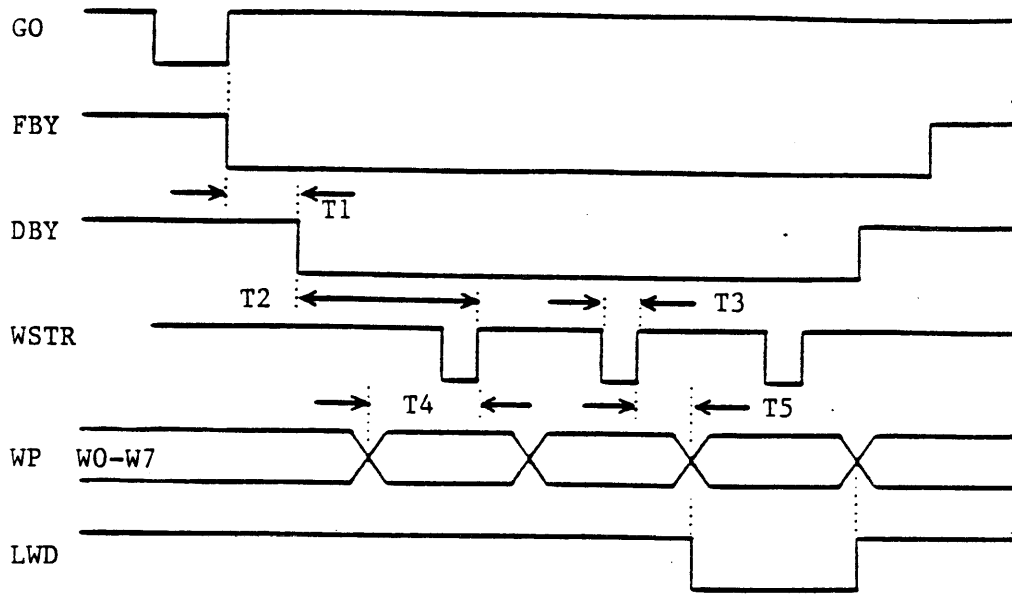

<u>Time</u>	<u>100ips Start/Stop</u>	<u>100ips On the Fly</u>	<u>50ips Start/Stop</u>	<u>50ips On the Fly</u>
T1	<18.0 mS	<4.0 mS	<8.0 mS	<5.0 mS
T2	>240 uS	>240 uS	>500 uS	>500 uS
T3	1.0 uS	1.0 uS	1.0 uS	1.0 uS
T4	>500 nS	>500 nS	>500 nS	>500 nS
T5	>250 nS	>250 nS	>250 nS	>250 nS

Figure 1-4. NRZI Write Data

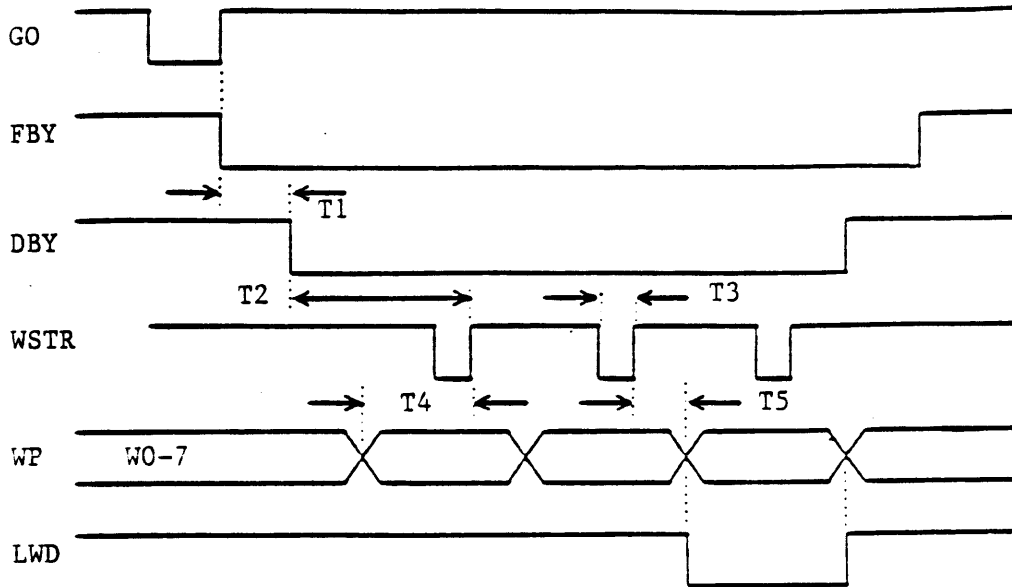

<u>Time</u>	<u>100ips Start/Stop</u>	<u>100ips On the Fly</u>	<u>50ips Start/Stop</u>	<u>50ips On the Fly</u>
T1	<18.0 mS	<4.0 mS	<8.0 mS	<5.0 mS
T2	>350 uS	>350 uS	>750 uS	>750 uS
T3	1.0 uS	1.0 uS	1.0 uS	1.0 uS
T4	>500 nS	>500 nS	>500 nS	>500 nS
T5	>250 nS	>250 nS	>250 nS	>250 nS

Figure 1-5. PE Write Data

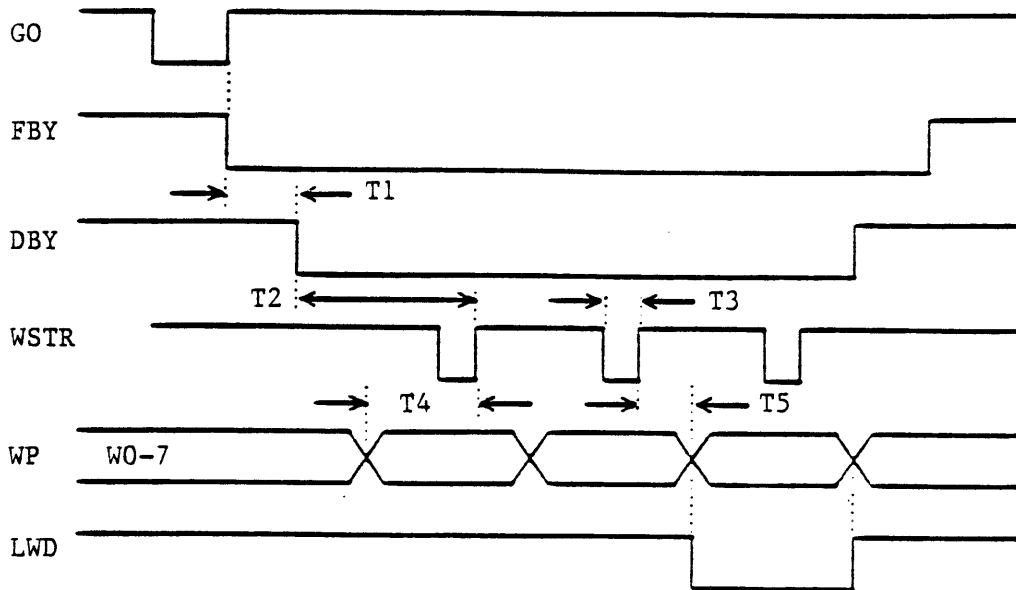

<u>Time</u>	<u>100ips Start/Stop</u>	<u>100ips On the Fly</u>	<u>50ips Start/Stop</u>	<u>50ips On the Fly</u>
T1	<18.0 mS	<4.0 mS	<8.0 mS	<5.0 mS
T2	>300 uS	>300 uS	>600 uS	>600 uS
T3	1.0 uS	1.0 uS	1.0 uS	1.0 uS
T4	>500 nS	>500 nS	>500 nS	>500 nS
T5	>250 nS	>250 nS	>250 nS	>250 nS

Figure 1-6. DDPE Write Data

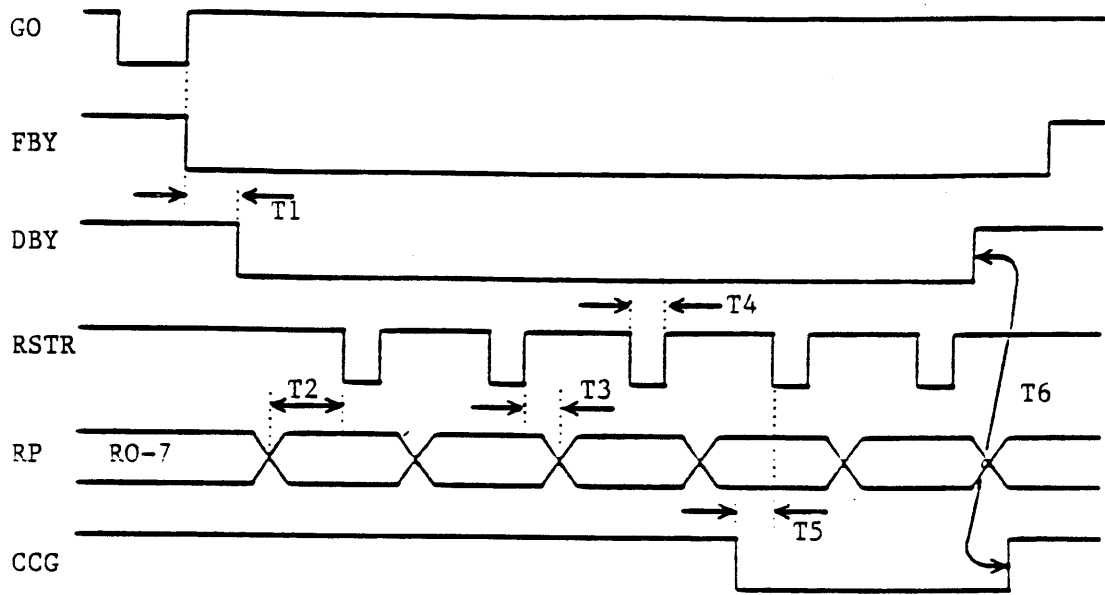

<u>Time</u>	<u>100ips Start/Stop</u>	<u>100ips On the Fly</u>	<u>50ips Start/Stop</u>	<u>50ips On the Fly</u>
T1	<18.0 mS	<4.0 mS	<8.0 mS	<5.0 mS
T2	>2.5 uS	>2.5 uS	>2.5 uS	>2.5 uS
T3	>250 nS	>250 nS	>250 nS	>250 nS
T4	2.36 uS	2.36 uS	2.36 uS	2.36 uS
T5	>2.5 uS	>2.5 uS	>2.5 uS	>2.5 uS
T6	* 70.5 uS	70.5 uS	67.3 uS	67.3 uS

* Nominal values

Figure 1-7. NRZI Read Forward

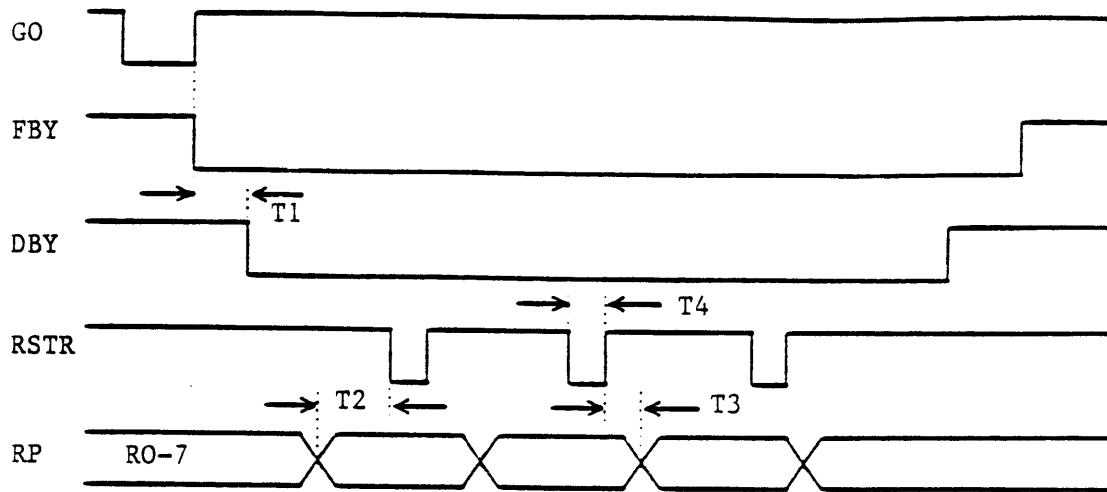

<u>Time</u>	<u>100ips Start/Stop</u>	<u>100ips On the Fly</u>	<u>50ips Start/Stop</u>	<u>50ips On the Fly</u>
T1	<18.0 mS	<4.0 mS	<8.0 mS	<5.0 mS
T2	>1.0 uS	>1.0 uS	>1.0 uS	>1.0 uS
T3	>250 nS	>250 nS	>250 nS	>250 nS
T4	670 nS	670 nS	670 nS	670 nS

Figure 1-8. PE Read Forward

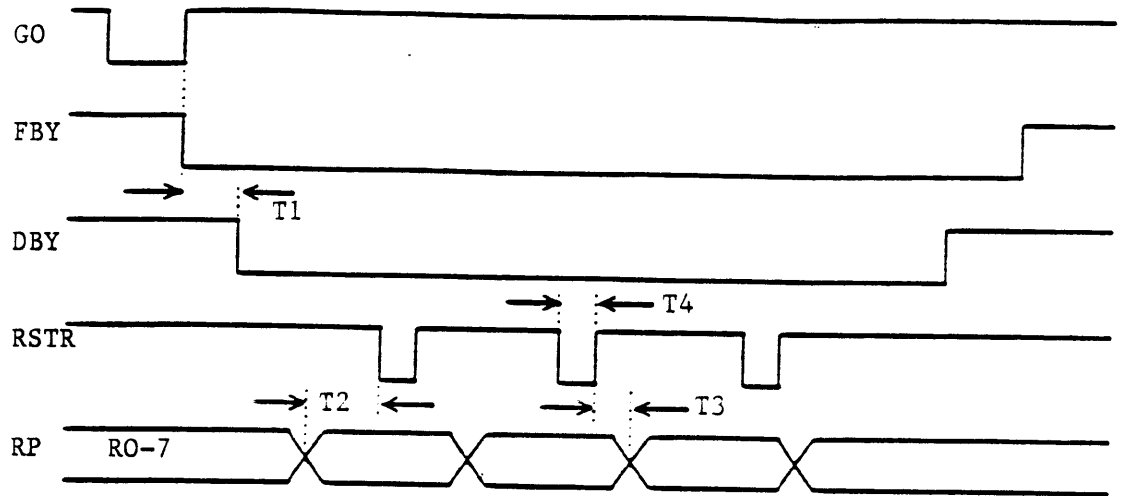

<u>Time</u>	<u>100ips Start/Stop</u>	<u>100ips On the Fly</u>	<u>50ips Start/Stop</u>	<u>50ips On the Fly</u>
T1	<18.0 mS	<4.0 mS	<8.0 mS	<5.0 mS
T2	>1.7 uS	>1.7 uS	>1.0 uS	>1.0 uS
T3	>250 nS	>250 nS	>250 nS	>250 nS
T4	670 nS	670 nS	670 nS	670 nS

Figure 1-9. DDPE Read Forward

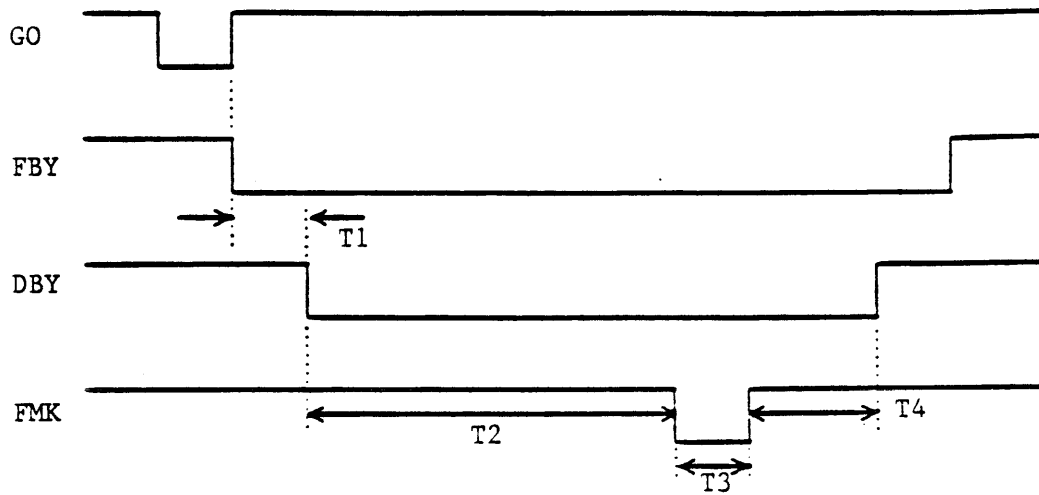

<u>Time</u>		<u>100ips Start/Stop</u>	<u>100ips On the Fly</u>	<u>50ips Start/Stop</u>	<u>50ips On the Fly</u>
T1		<54.0 mS	<40.0 mS	<80.0 mS	<80.0 mS
T2	*	1.8 mS	1.8 mS	3.6 mS	3.6 mS
T3		4.15 uS	4.15 uS	4.15 uS	4.15 uS
T4	*	53.0 uS	53.0 uS	53.0 uS	53.0 uS

* Nominal Values

Figure 1-10. NRZI Write File Mark

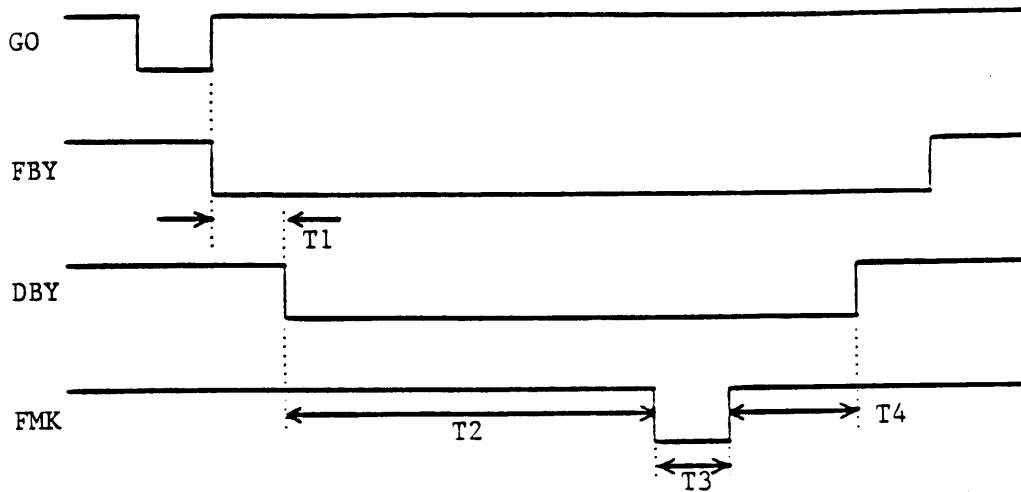

<u>Time</u>		<u>100ips Start/Stop</u>	<u>100ips On the Fly</u>	<u>50ips Start/Stop</u>	<u>50ips On the Fly</u>
T1		<54.0 mS	<40.0 mS	<80.0 mS	<80.0 mS
T2	*	1.8 mS	1.8 mS	3.6 mS	73.6 mS
T3		3.2 uS	3.2 uS	6.3 uS	6.3 uS
T4	*	220 uS	220 uS	220 uS	220 uS

* Nominal Values

Figure 1-11. PE Write File Mark

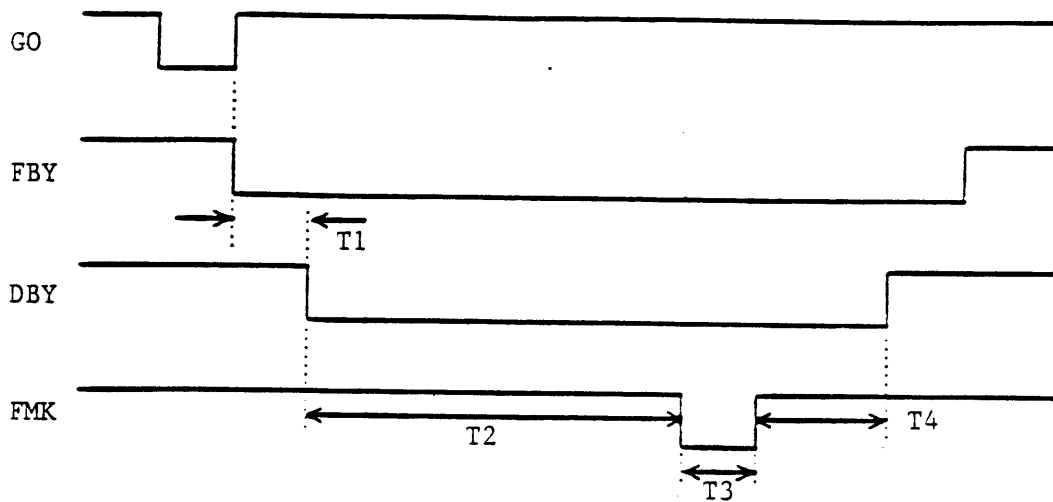

<u>Time</u>		<u>100ips Start/Stop</u>	<u>100ips On the Fly</u>	<u>50ips Start/Stop</u>	<u>50ips On the Fly</u>
T1		<54.0 mS	<40.0 mS	<80.0 mS	<80.0 mS
T2	*	1.8 mS	1.8 mS	3.6 mS	3.6 mS
T3		1.6 uS	1.6 uS	3.2 uS	3.2 uS
T4	*	220 uS	220 uS	220 uS	220 uS

* Nominal Values

Figure 1-12. DDPE Write File Mark

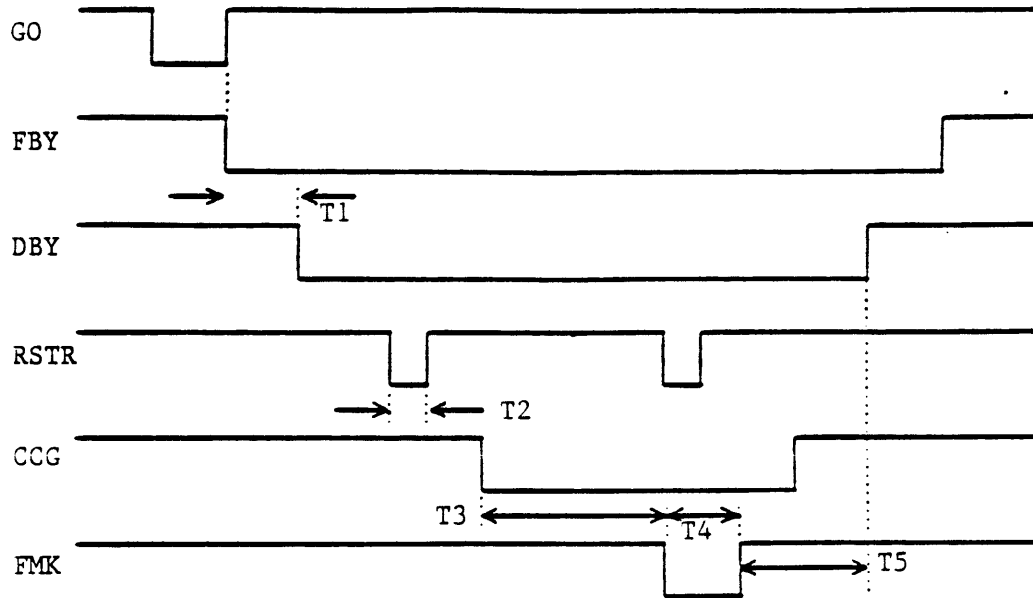

<u>Time</u>		<u>100ips Start/Stop</u>	<u>100ips On the Fly</u>	<u>50ips Start/Stop</u>	<u>50ips On the Fly</u>
T1		<18.0 mS	<4.0 mS	<8.0 mS	<5.0 mS
T2		2.36 uS	2.36 uS	2.36 uS	2.36 uS
T3	*	300 uS	300 uS	450 uS	450 uS
T4		4.2 uS	4.2 uS	4.2 uS	4.2 uS
T5	*	37.0 uS	37.0 uS	41.0 uS	41.0 nS

* Nominal Values

Figure 1-13. NRZI Read File Mark

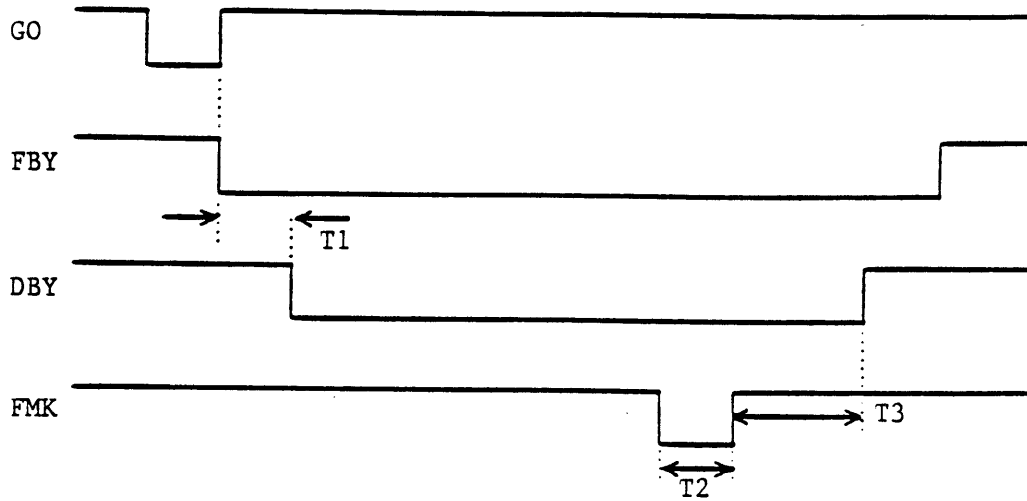

<u>Time</u>	<u>100ips Start/Stop</u>	<u>100ips On the Fly</u>	<u>50ips Start/Stop</u>	<u>50ips On the Fly</u>
T1	<18.0 mS	<4.0 mS	<8.0 mS	<5.0 mS
T2	3.2 uS	3.2 uS	6.3 uS	6.3 uS
T3	* 190 uS	190 uS	190 uS	190 uS

* Nominal Values

Figure 1-14. PE Read File Mark

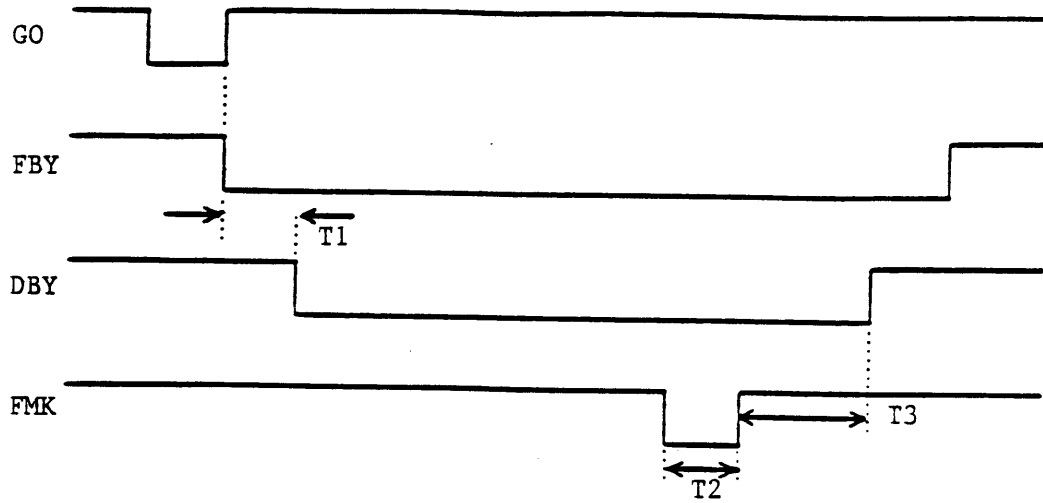

<u>Time</u>	<u>100ips Start/Stop</u>	<u>100ips On the Fly</u>	<u>50ips Start/Stop</u>	<u>50ips On the Fly</u>
T1	<18.0 mS	<4.0 mS	<8.0 mS	<5.0 mS
T2	1.6 uS	1.6 uS	3.2 uS	3.2 uS
T3	* 190 uS	190 uS	190 uS	190 uS

* Nominal Values

Figure 1-15. DDPE Read File Mark

SECTION II
INSTALLATION/OPERATION

SECTION II INSTALLATION AND OPERATION

2.0 INTRODUCTION

Section II describes unpacking, inspecting, installing, cabling, adjusting, and operating the Model 9600B/9650B Tape Drive.

2.1 UNPACKING

WARNING

The Model 9600B Tape Drive weighs 110 pounds. Use safe lifting practices to remove the drive from the container.

The Model 9600B and 9650B Tape Drives are shipped cushioned by polyethylene foam supports in a heavy-weight cardboard container. Place the shipping container on a flat, horizontal, dry, non-slip surface. Carefully cut the binding straps, and remove the top lid. Remove the cardboard sides of the shipping container. The Drive can now be conveniently lifted from the shipping container. Set the Drive on a flat, horizontal surface. Save the following items: Slide Rails, AC Power Cord, alternate voltage Fuse Kit, Hardware (two Shipping Retainer Brackets, Rack-Latch Angle Bracket, screws, etc.) and 9600B/9650B Manual. Retain the shipping container, polyethylene wrap, and foam supports for possible future shipment.

Tape Drives shipped in racks may be held in place by the two Shipping Retainer Brackets mentioned above (Figure 2-1). These Brackets should be removed after the Rack is put in its final location at the installation site, and the Rack-Latch Angle Bracket (also mentioned above) must be installed in place of the left Retainer Bracket. This Bracket comprises the Catch (Figure 2-1) for the Retainer Latch located just inside the Front Panel.

2.2 INSPECTION

Inspect the drive for shipping damage such as scratches, dents, or cracks in the frame. On the Dust Cover (top of Drive), turn the two holding fasteners 1/4 turn counterclockwise and open the dust cover. With the Cover Support Bar (Figure 2-2), latch the Dust Cover in Maintenance Position. Check for loose or missing parts, and foreign material. Open the Tape Path Cover and verify that all parts/areas of the tape path are clean. Remove the PCBA Cover and verify that all PC Boards (Figure 2-4) are seated properly. Reinstall PCBA Cover.

2.3 CABLING AND DAISY CHAINING REQUIREMENTS

The user must provide Host-to-Drive interconnect cables. Up to eight Drives can be daisy chained, but combined cable length must not exceed 20 feet. Terminators U3, U4, and U11 must be removed from all Drive Formatter Boards except from the last Formatter Board on the daisy chain. To remove the Terminators:

1. Remove Top Cover at rear top of the Drive.
2. As applicable, disconnect two cables from the Formatter Board (Figure 2-4).
3. Grasp the PCB Ejectors firmly, and pull Ejectors toward the side of the unit. Board should pop partially out of the slot.
4. Locate Terminators U3, U4 and U11 (Figure 2-4), and remove them.
5. Replace the Formatter Board and Top Cover.

Recommended connectors and cables are as follows: - Daisy chains may optionally require a Cable Connector Adapter (See Figures 2-3 and 2-5).

<u>Item</u>	<u>Vendor</u>	<u>Part Number</u>	<u>Specifications</u>
Connectors:			50-pin, card edge
Adapter:	Kennedy	90-08018-001	50-pin, 3-port
Cables:			50-wire, 28-AWG, shielded/ flat/stranded/jacketed

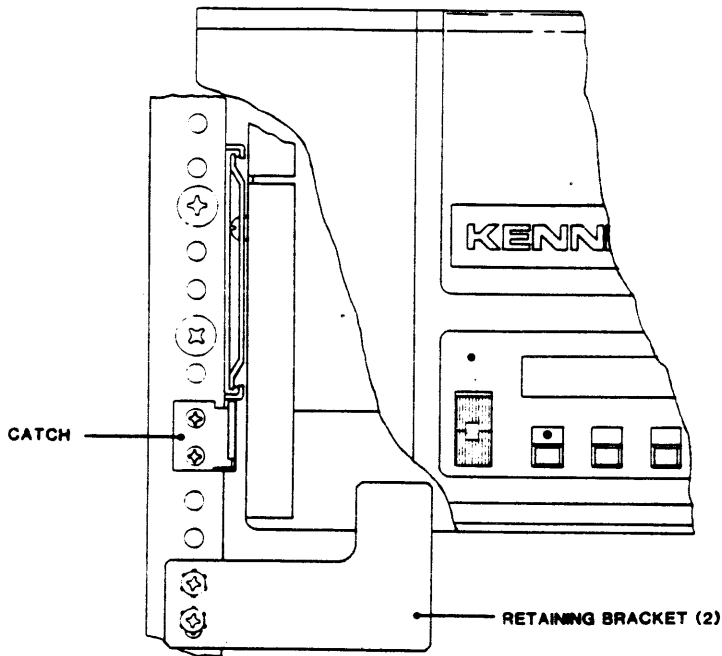

Figure 2-1. Shipping Retainer Bracket and Catch

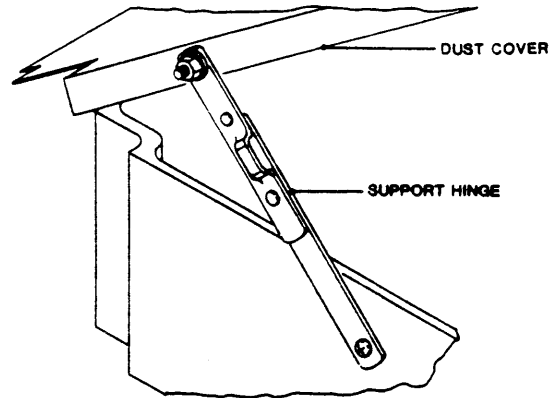

Figure 2-2. Dust Cover Support Bar

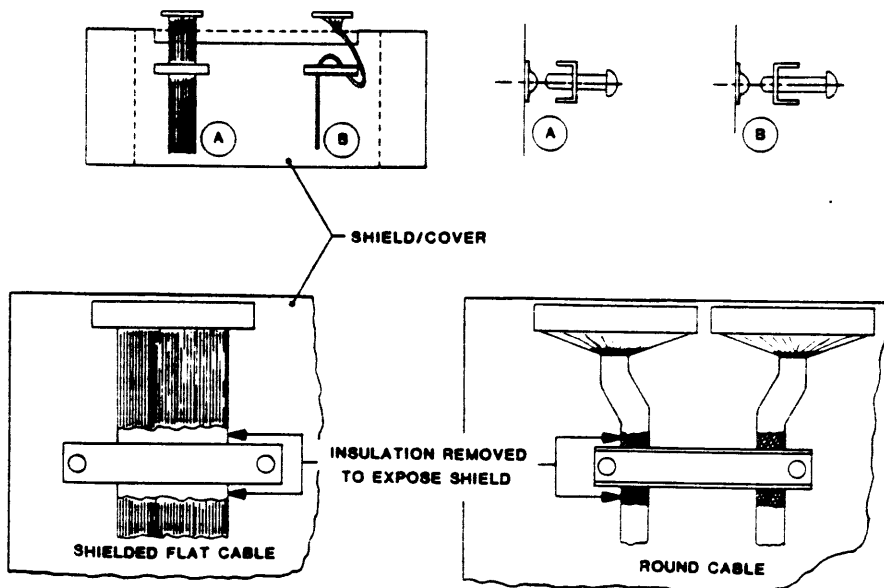

Figure 2-3. Grounding Cable Clamp Details

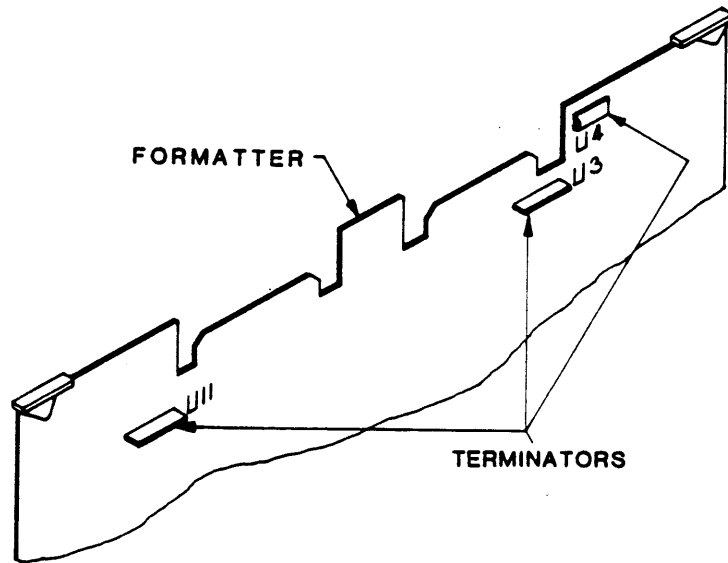
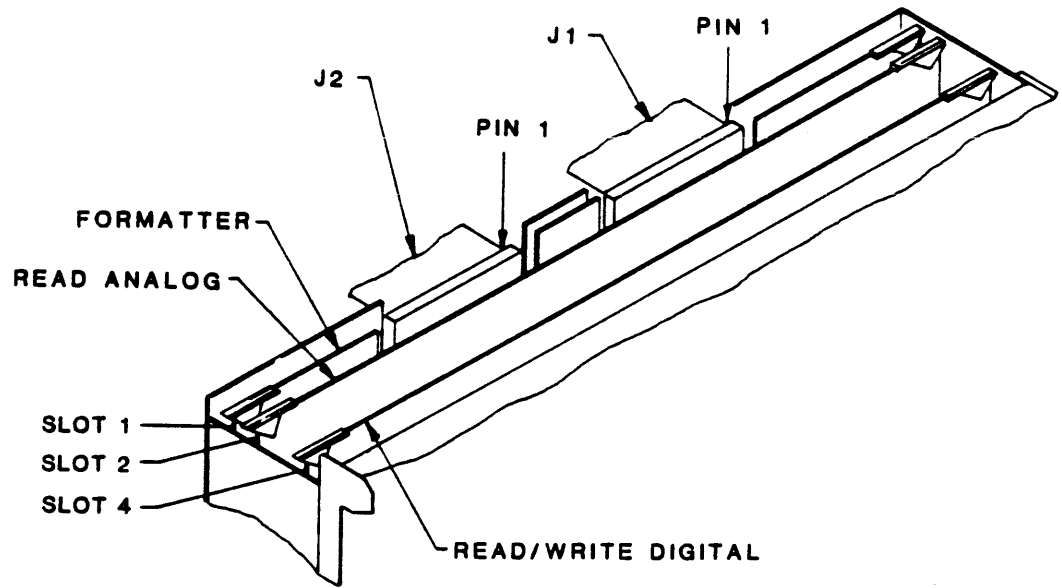
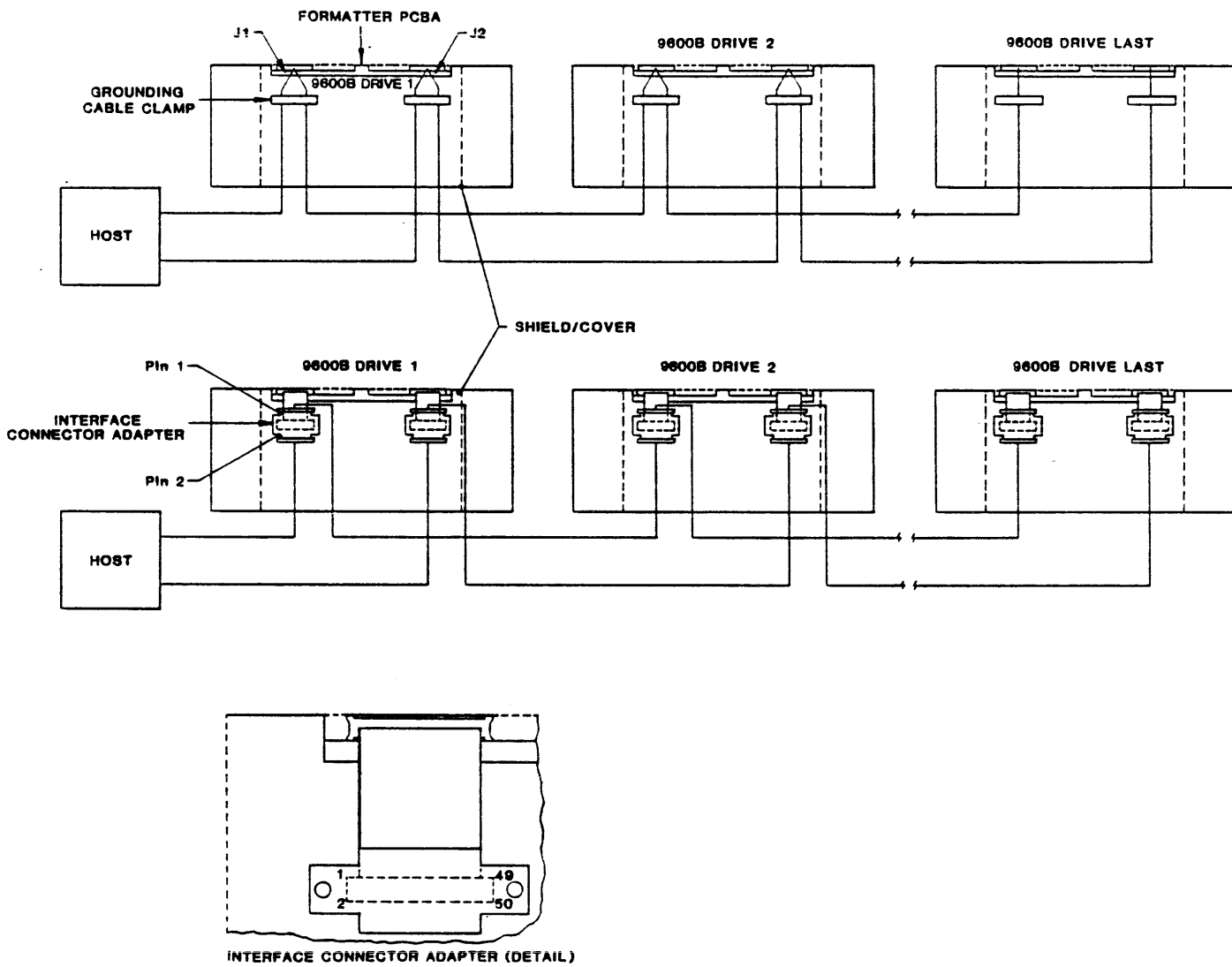

Figure 2-4. Card Cage, Cables, And Terminators



NOTE:

1. Terminators removed from all but last Drive.
2. Shielded Cables are required to meet FCC Regulations. Ground the shields as illustrated. For Interface Connector Adapter, remove some insulation from the cable and connect cable shield under an Adapter Mounting Screw.

Figure 2-5. Daisy Chaining

2.4 INSTALLATION

2.4.1 TABLE-TOP INSTALLATION

Place the Drive on a flat table top with dimensions to accommodate the Drive (Figure 2-6), of sufficient strength to support the weight of the Drive, and allow sufficient clearance for maintenance access. Do Steps E and F in paragraph 2.4.2.2.

2.4.2 RACK-MOUNT INSTALLATION

Mount the Tape Drive (Figure 2-7) in a standard EIA/RETMA 19-inch Rack allowing at least 8-3/4 inches vertical space. Install The Rack-Mount Rail Assembly supplied with the Drive as described in the following subparagraph 2.4.2.1.

2.4.2.1 RAIL ASSEMBLY COMPONENT CHECKOUT

The Rack-Mount Rail Assembly consists of two left/right interchangeable Track Subassemblies. Each consists of the following items:

<u>ITEM</u>	<u>Outer/Center Track Assembly</u>	<u>ITEM</u>	<u>Outer/Center Track Assembly</u>
1	Center Track	5	One Adjustable Mounting Bracket
2	Outer Track	6	Three Nut Plates
3	Fixed Mounting Bracket	7	Six 10-32 by 1/2-inch Panhead Screws
4	One Chassis Rail	8	Retention Latch Bracket

Note: The standard Rack-Mount Rail Assembly has rails that fit cabinets up to 24 inches deep. For deeper cabinets, use Slide Extender P/N 28-00352-101.

Order from Kennedy Co. Spare Parts Order Department, 9292 Jeronimo Rd., Irvine, CA 92718. Tel: (714) 770-1100.

2.4.2.2 MOUNTING PROCEDURE

A. Install one of the Track Assemblies (Figure 2-8) on either side of the 19-inch Rack as follows:

1. Using the 10-32 Slotted Screws (7) and Nut Plates (6)* provided, loosely assemble an Adjustable Mounting Bracket (5) to the rear of the Right Track Assembly.
*Nut Plates not required for Racks with threaded mounting holes.
2. Measure upward 2 inches from the bottom of the Rack opening allotted for the Drive, and mark the Rack at that point.
3. Aligning the bottom of the Fixed Mounting Bracket (3) at the 2-inch mark on the front of the 19-inch Rack, and using the 10-32 Screws (7) provided, mount the Fixed Mounting Bracket (3) to the front of the 19-inch Rack, and mount the Adjustable Mounting Bracket (5) (loosely attached to the rear of the Center Track) to corresponding holes in the rear of the 19-inch Rack. Level the Track and tighten all Screws.
4. Repeat Steps 1 through 3 for mounting the other Track Assembly.

B. Inspect all work and check that all screws are tight.

C. Remove power cable from the Drive Chassis.

D. With a minimum of two persons, one on each side of the Drive, lift and guide the Chassis Rails onto the Left and Right Center Tracks. Verifying that the rails are correctly aligned, push the Drive into the Rack.

- E. Remove about an inch of insulation from each Interface Cable at a point where the Cable will pass under the Grounding Cable Clamp(s). This will expose the cable shield. Run the Interface Cables under the Cable Clamp(s) as illustrated in Figure 2-3. Tighten the Clamp(s).
- F. Locate mounting holes on the front of the rack that align with Retention Latch on the Drive, located just within the front plastic access door to the left. Mount the Retention Latch Bracket (Item 8) so that it meshes with the Retention Latch Armature when the Drive is slid all the way into the rack.

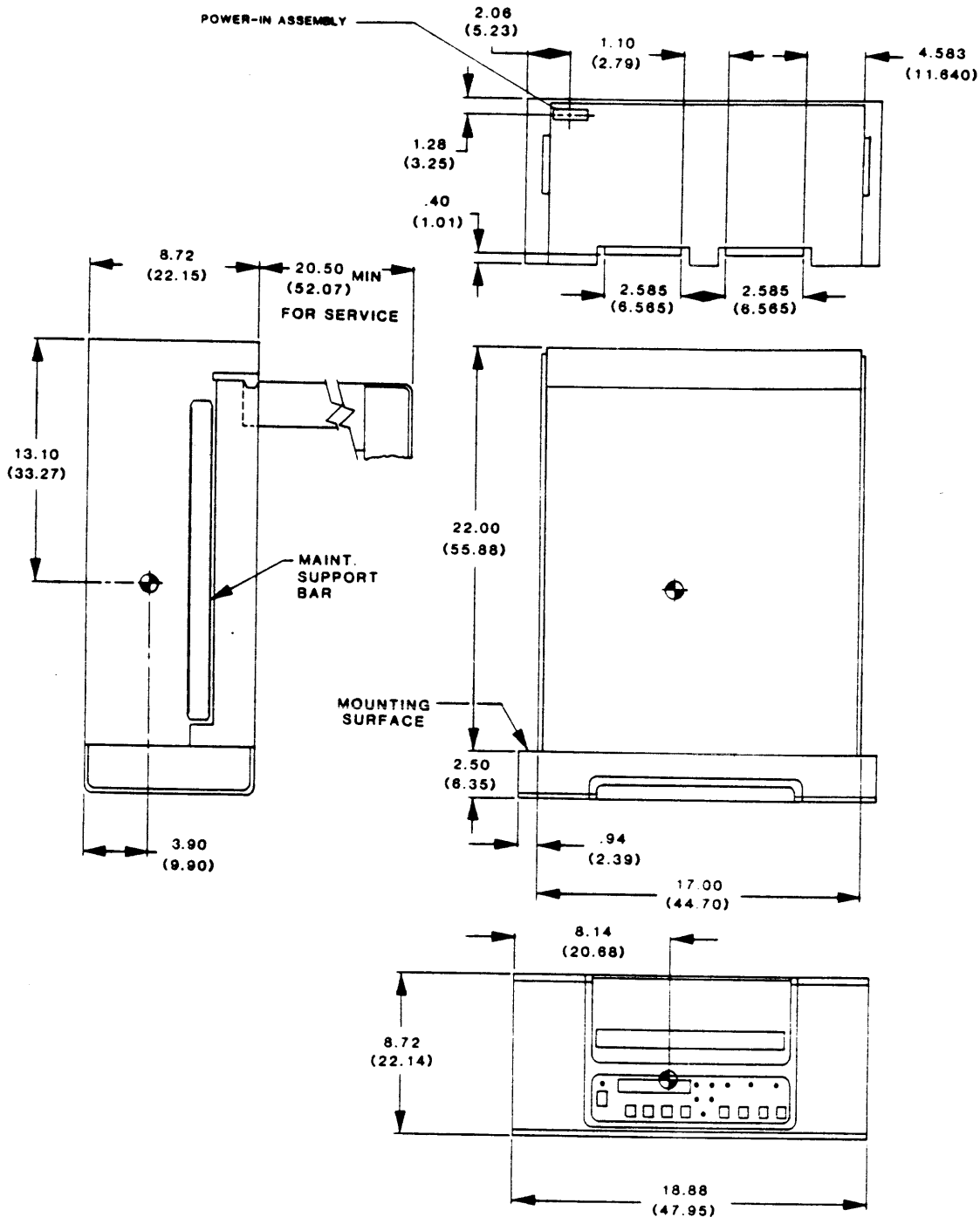

Figure 2-6. Outline And Installation Drawing, Model 9600B

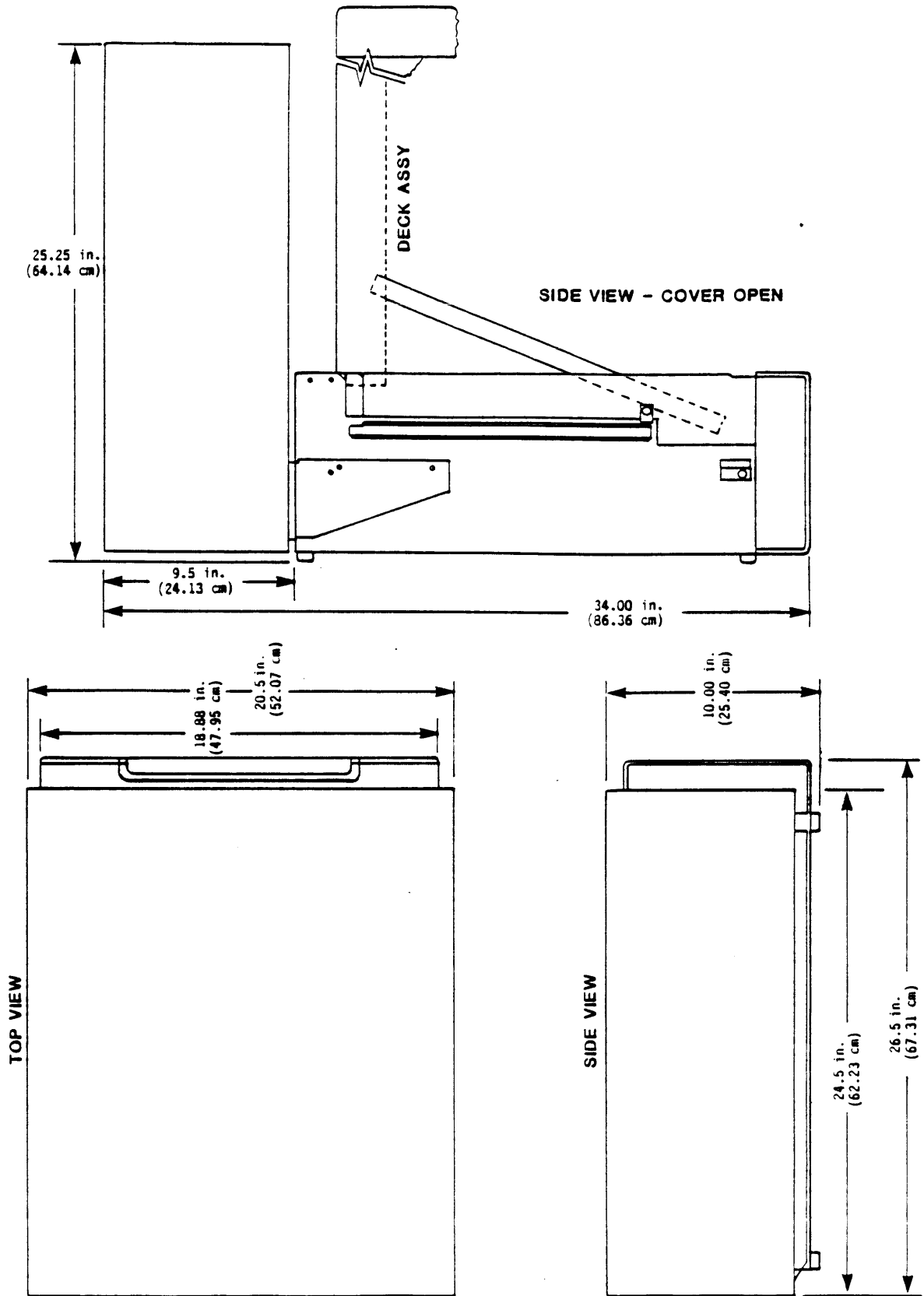

Figure 2-7. Installation and Outline Drawing, Model 9650B

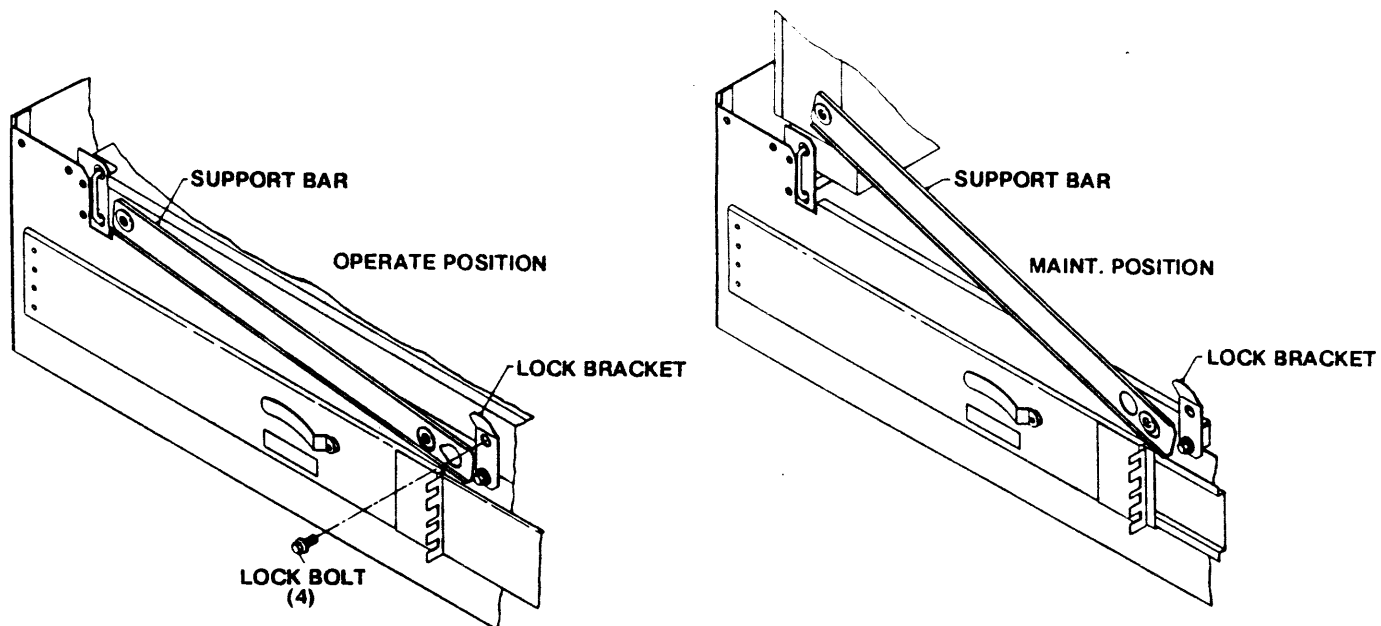

Figure 2-7A. Deck Assembly Support Bar

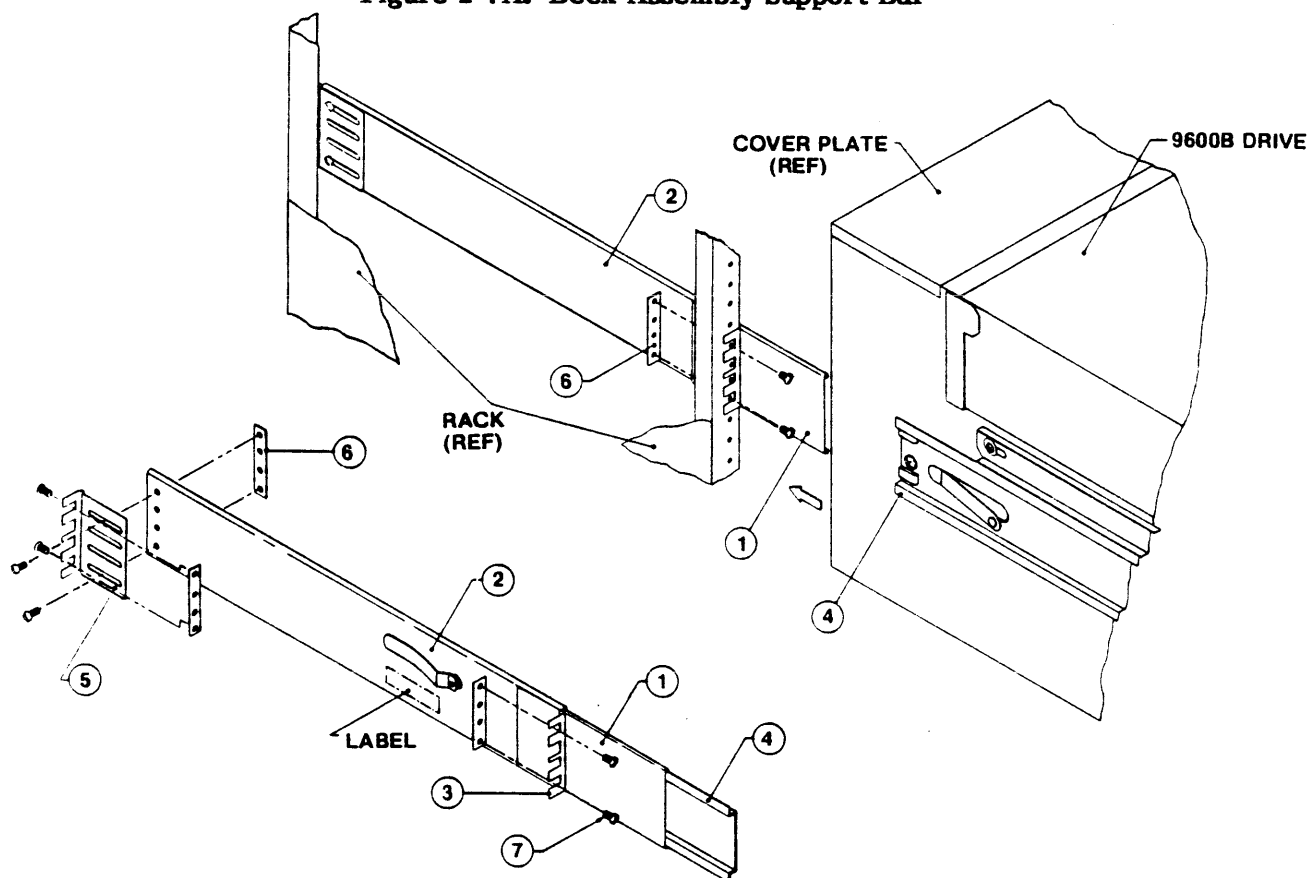

Figure 2-8. Track Subassembly

2.5 POWER UP AND INITIAL CHECKOUT

2.5.1 LINE VOLTAGE

2.5.1.1 AC LINE VOLTAGE (100-, 120-, 220-, or 240-Volt Operation)

The Drive is normally factory-set for 120-volt operation. Other voltage choices can be 100, 220, or 240. Locate the Power-In Assembly (Figure 2-9) at the rear of the unit (Figure 2-6). The Voltage Selector Card behind the plastic slide cover is installed with "120" legible. This indicates that the Drive is set for 120-volt operation. The following subparagraph describes changing this setting as necessary.

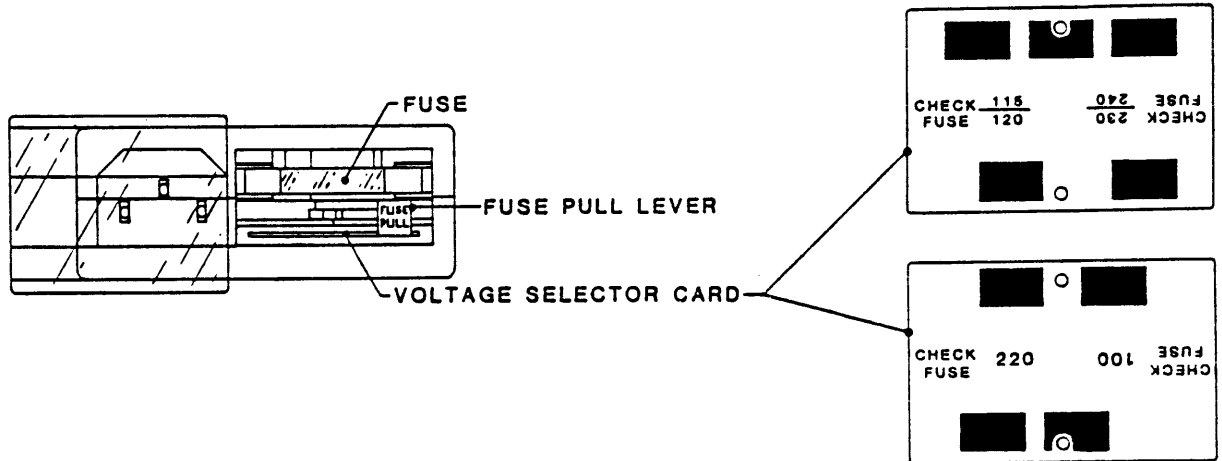

Figure 2-9. Power-In Assembly

Changing Operating Voltage:

Assuming that the Voltage Selector Card setting is other than the site voltage, proceed as follows:

- A. Remove the AC power cord (if installed) from the Power-In Assembly (Figure 2-9).
- B. Slide the plastic Fuse Cover to the left.
- C. Rotate the "FUSE PULL" lever to the left, and remove the fuse (if fuse is incorrect size).
- D. Using long nose pliers, remove the Voltage Selector Card.
- E. Position the Voltage Selector Card at the entrance to the card slot so that the correct voltage (100, 120, 220, or 240) is legible (facing upward), and install the Voltage Selector Card into the Power-In Assembly.
- F. Install the proper-size fuse (supplied: 3-amp slo-blo for 220/240-Volt; 6-amp for 100/120-Volt).
- G. Slide the plastic Fuse Cover to the right.
- H. Install (as applicable) an appropriate power plug on the source end of the power cord.
- I. Reconnect the power cord to the Power-In Assembly and plug the other end of the power cord into an appropriate AC outlet.

2.5.1.2 DC LINE VOLTAGE (48, 60VDC Operation)

The drive is factory wired for either 48 or 60VDC as specified on the voltage label on the rear of the unit.

2.5.2 POWER UP

- A1. On AC units, check that the Voltage-Selector is set for the line voltage of the installation site per paragraph 2.5.1.1 or 2.5.1.2.
- A2. On DC units, check that the voltage label specifies the correct line voltage.
- B. Turn Power ON-OFF switch ON (Figure 2-10).
- C. Check that the Power-On LED (unmarked, located above the Power switch), and that the Character Display Readout indicates "TESTING" for a short time followed by "UNIT X" (X represents the Drive Unit Number. The initial (default) readout is "UNIT 0").

2.5.3 CHECKOUT

NOTE: Diagnostics is enabled by the Diagnostics Jumper set to ENABLE. If Diagnostics Switches do not operate, see Section V, paragraph 5.4.2.9.

2.5.3.1 LOADING TAPE

- A. Swing open the Tape Access Door as shown in Figure 2-11, and mount a reel of tape onto the Hub. The reel must be properly seated with Write Enable Ring facing downward toward the Deck Plate, and the tape leader should be loose.
- B. Close the Tape Access Door.
- C. Depress LOAD. The Readout displays "LOADING". The supply reel spins slowly three turns in reverse to ensure that tape is properly wound on the Reel. The Drive vacuum system automatically threads and loads tape onto the Take-up Reel. The loading process continues until the tape reaches the Beginning of Tape (BOT). At BOT, the LOAD and LOAD PT (Load Point) LEDs light and the Readout displays "UNIT X". If the Supply Reel has the Write Enable Ring installed, the WRITE ENABLE LED should be lit.

NOTE: Some tapes fail to load because they develop an electrostatic charge. This can be recognized by observing the tendency for the tape to cling to itself around the Supply Reel. This can be remedied by trimming the end of the tape with a trimming/crimping tool.

2.5.3.2 LOAD DETAILS

- A. If the Load Sequence does not complete satisfactorily, an Error Message displays. See Section III, Table 3-3 for error information and remedial action.
- B. After the tape is wound on the Take-up Reel, the Buffer Arms move inward, their Rollers engaging and tensioning tape across the Magnetic Head.
- C. At the end of the Load Sequence, tape is tensioned, and at BOT, the Front Panel displays UNIT X, and the LOAD and LOAD PT LEDs are lit. If the tape is Write Enabled, the WRITE EN LED is lit.

2.5.3.3 CHECKOUT CONTINUED

Having loaded tape per 2.5.3.1 above:

- A. Depress ON-LINE. ON-LINE LED lights; the Readout continues to display "UNIT X". When the Drive is selected, the SELECT LED lights.
- B. Depress ON-LINE. ON-LINE LED goes out.
- C. Depress DIAG. DIAG LED lights and the Readout displays "DIAG".
- D. Depress ENTER. Readout displays "SELFTEST".
- E. Repeatedly press SCAN and verify that the Readout displays, in turn, the following: "SELFTEST, MOTION, DRV ADJ, SET UP, CAL, DATADIAG, SELFTEST, MOTION."
- F. With "MOTION" displayed, press ENTER. Readout displays "50 FWD" (50 ips Forward).
- G. Repeatedly press SCAN and verify that each time SCAN is pressed the Readout displays as indicated in Table 2-1 beginning with Step 2, then to Step 1 and repeating the sequence.
- H. Repeatedly press SCAN until Readout displays "100 FWD".
- I. Press ENTER. Tape moves forward at 100 ips, the LOAD PT LED goes out, and the DIAG LED blinks. Let Drive run to the End of Tape (EOT). Readout displays "EOT".

Table 2-1. Motion Control Sequence

STEP	DISPLAY			MOTION
	NORMAL *	AT EOT	AT BOT	
1	50 FWD	EOT		50 ips Forward
2	50 REV		BOT	50 ips Reverse
3	50 FSS	EOT		50 ips Forward Start/Stop
4	50 RSS		BOT	50 ips Reverse Start/Stop
5	50 FRF	EOT	BOT	50 ips Forward/Reverse/Forward
6	100 FWD	EOT		100 ips Forward
7	100 REV		BOT	100 ips Reverse
8	100 FSS	EOT		100 ips Forward/Start/Stop
9	100 RSS		BOT	100 ips Reverse/Start/Stop
10	100 FRF	EOT	BOT	100 ips Forward/Reverse/Forward
11	50/100 F	EOT		50 ips/100 ips Forward
12	50/100 R		BOT	50 ips/100 ips Reverse
13	BURN IN			50 ips/100 ips/50 ips (Forward)/ Auto Rewind/...(Repeat) etc.

***NOTE:** Normal display is defined as any display when the tape is neither at BOT or EOT

- J. Scan through the entire menu. In the step for any Forward Motion Command, such as Step 1 (50 FWD), Step 3 (50 FSS), Step 5 (50 FRF), etc., the Display reads "EOT".
- K. Depress SCAN. Readout displays "100 REV".
- L. Depress ENTER. Tape runs at 100 ips in reverse. Let Drive run to the Beginning of Tape (BOT). Readout displays "BOT".
- M. Scan through the entire menu. In the step for any Reverse Motion Command, such as Step 2 (50 REV), Step 4 (50 RSS), etc., the Display reads "BOT" and the Command cannot be entered.
- N. Repeatedly depress DIAG until DIAG LED goes out and Readout displays "UNIT X".
- O. Depress RWND/UNL. Tape rewinds to the supply reel, and Readout displays "UNLDNG" until tape is unloaded (stops motion), then the readout displays "UNIT X".
- P. Open the Tape Access Door, remove the tape, and turn off power.
- Q. Run DATATEST in Checkout procedure to verify Write/Read performance.

2.5.3.4 MOTION TEST SUMMARY

All Motion Tests, with the exception of Burn In, automatically stop at either BOT (Reverse Tests) or EOT (Forward Tests). Burn In consists of a 100/50/100 ips forward sequence until EOT is reached. At EOT, the Drive automatically rewinds tape to BOT at 200 ips. At BOT, the Drive repeats the 100/50/100 ips sequence and continues to repeat until the operator intervenes. All Motion Tests, including Burn In, may be stopped by depressing START/STOP, except when rewinding.

2.5.4 UNIT SELECTION

The Drive is factory-set for Unit Address 0. In daisy-chained systems, set the Unit Address for each Drive (other than Drive 0) as follows:

- A. Turn AC power ON.
- B. In turn, depress DIAG, ENTER, SCAN, SCAN, SCAN. Readout displays in sequence: "DIAG", "SELFTTEST", "MOTION", "DRV ADJ", SET UP".
- C. Depress ENTER. Drive enters SET UP Mode; Readout displays "UNIT NUM".
- D. Depress ENTER. Readout displays "UNIT X".
- E. Repeatedly depress SCAN until the Readout displays the desired Unit Number.
- F. Depress ENTER. Readout displays "LOAD?".
- G. Depress LOAD to save new Unit Number. Drive displays "DENS SEL" (the next parameter).
- H. The Drive will now respond to the new Unit Number (address) sent from the Host.
- I. Depress DIAG twice to return the Drive to Off Line status. The Readout displays the new Unit Number.

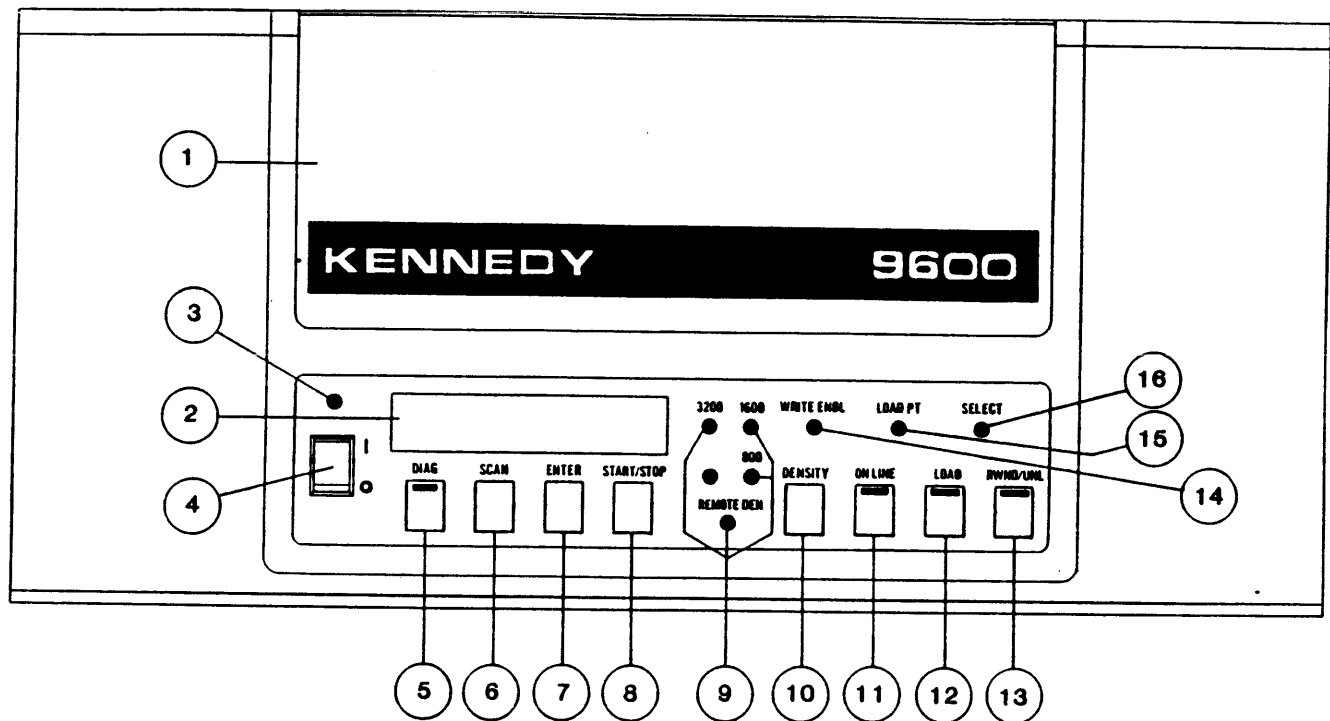

- (1) **Tape Access Door** - Supply Hub Access (Ref).
- (2) **Character Display Readout** - Displays operating mode, status, parameters, and diagnostic messages.
- (3) **Unmarked LED** - Lights when AC power is applied to Drive.
- (4) **ON/OFF Switch** - Controls AC power to Drive.
- (5) **DIAG Pushbutton** - Turns diagnostics ON and OFF when Drive is off-line. Internal LED lights when in the diagnostics mode.
- (6) **SCAN Pushbutton** - Scans diagnostics and calibrate menus.
- (7) **ENTER Pushbutton** - Enters selected commands when in diagnostics or calibrate mode.
- (8) **START/STOP Pushbutton** - Starts or stops selected commands in the diagnostics or calibrate mode.
- (9) **REMOTE DEN LED** - Lights when density is selectable by Host.
- 800/1600/3200 LEDs** - Indicates selected density.
- (10) **DENSITY Pushbutton** - Selects data density (800, 1600 or 3200) and REMOTE.
- (11) **ON-LINE Pushbutton** - Puts unit online or takes unit offline. Lights when Drive is On-line.
- (12) **LOAD Pushbutton** - Initiates Load sequence. Lights when drive is loaded.
- (13) **RWND/UNL Pushbutton** - Initiates Rewind or Unload when Drive is Off-line.
- (14) **WRITE ENBL LED** - Lights when supply reel is not write protected.
- (15) **LOAD PT LED** - Lights when tape is at Load Point.
- (16) **SELECT LED** - Lights when Drive is selected by the Host.

Figure 2-10. Panel Controls and Indicators

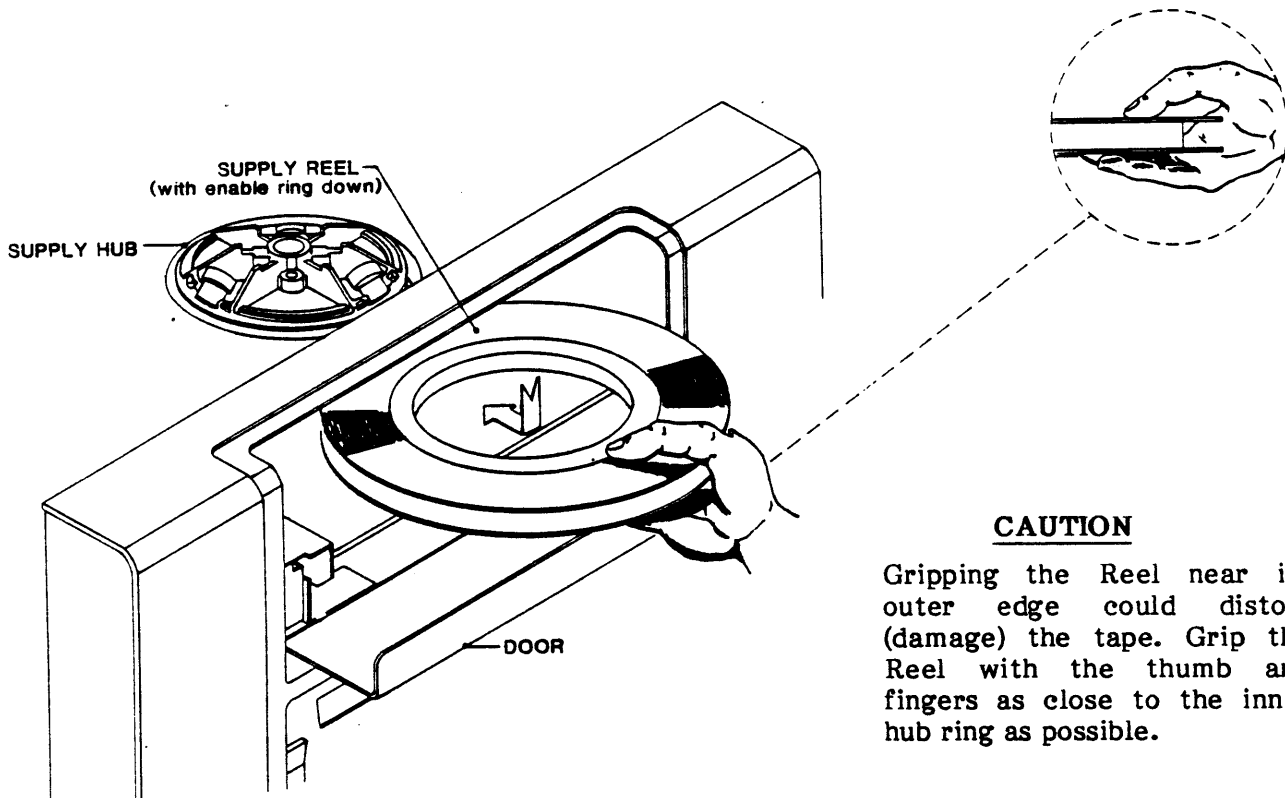
**CAUTION**

Gripping the Reel near its outer edge could distort (damage) the tape. Grip the Reel with the thumb and fingers as close to the inner hub ring as possible.

Figure 2-11. Installing Supply Reel

2.5.5 DATA DENSITY - INTRODUCTION

The Model 9600B/9650B can operate at 800 CPI density in Nonreturn-to-Zero (NRZI) format, at 1600 CPI density in Phase-Encoded (PE) format, at 3200 CPI Density in Double Density PE (DDPE) format. When powered up, the Drive automatically defaults* to 1600 REMOTE, in which the Host controls density selection for Write Operations.** The operator can override the defaulted operating density by operating the Front Panel DENSITY Switch as described under A below:

* Default Density is factory-set, but can be changed as described below under C. **Changing Default Density.**

**In Remote Density Mode, the Host controls Density by Command issued at BOT only; but when reading tape, the Drive automatically selects the density of the tape currently loaded.

A. **Changing Operating Density:**

1. If tape is loaded, rewind tape to BOT and set the Drive to off-line. The Readout displays UNIT X and the current operating density and mode on the density LEDs and the Remote Led. The Drive is in Remote PE Mode.

2. Repeatedly, as necessary, press DENSITY. The Indicators will light in the following sequence, putting the Drive in the corresponding Density Mode. Leave the Drive in the desired Mode.

<u>Mode</u>	<u>LEDs Lit</u>		<u>Mode</u>	<u>LEDs Lit</u>	
	<u>Dens</u>	<u>Control</u>		<u>Dens</u>	<u>Control</u>
a. Local NRZI	800		e. Local DDPE	3200	
b. Remote NRZI	800	REMOTE DEN	f. Remote DDPE	3200	REMOTE DEN
c. Local PE	1600				
d. Remote PE	1600	REMOTE DEN			

NOTE: If the drive is configured to operate in REMOTE density only the local selections will be skipped.

B. Operation:

1. In Read operations, if the Drive is in Remote Mode, the Drive reads automatically in the density in which the tape was written.
2. In Write operations, the Drive writes in the density indicated by the Density LEDs.

C. Changing Default Density:

1. Enter diagnostics mode by pressing the DIAG button. The readout will display DIAG and the LED in the DIAG button will illuminate. Press the ENTER key to enter diagnostics mode.
2. Press the SCAN button 3 times. The readout will display, in sequence: "SELFTEST, MOTION, DRV ADJ, SET UP".
3. Press the ENTER button to enter set-up mode. The readout will display "UNIT NUM".
4. Press the SCAN key once. The readout will display "DENS SEL".
5. Press the ENTER button. The readout will display "NORMAL" indicating the drive will allow execution in local density mode. If operation in remote mode only is desired, press the SCAN button and the readout will show "REM ONLY". When the desired option is shown, press the ENTER button to select it.
6. The readout will display "LOAD?". Press the LOAD button to save the selected option.
7. The readout will then display "DFLT DEN". Press the ENTER button to select the default density. The readout will display "1600 REM" (the factory set default density).
8. Repeatedly press SCAN until the desired default density is displayed. The sequence of displays is:

a. 800	c. 1600	e. 3200
b. 800 REM	d. 1600 REM	f. 3200 REM

NOTE: Only the remote density selection will be shown if the REM ONLY option was selected in step 5.

9. When the desired default density is selected press ENTER. The readout will display "LOAD?". Press the LOAD button to save the selection.
10. Press the DIAG button repeatedly until the LED in the DIAG button turns off to exit diagnostics mode.

2.6 OPERATING INSTRUCTIONS

2.6.1 OPERATING PROCEDURE

- A. Turn Power On. Readout displays "TESTING" and if the Drive passes all tests, the Readout displays "UNIT X". Fault Conditions that could occur during Power Up, and possible related failures, are listed and described in Section III.
- B. Place Tape Reel on Reel Hub with Write Enable Ring facing downward.
- C. Depress LOAD*. The Readout displays "LOADING" and the Drive automatically loads tape. When loading is successful, the Readout displays "UNIT X" and the WRITE ENBL, LOAD POINT, and LOAD LEDs light. If loading is unsuccessful, the Readout displays a diagnostic message such as: CHK HUB, ABORTED, REV REEL, etc., or a Failure Code, and the RWND/UNL LED flashes.

*Or Host can send a Load On-Line Command (ILOL) to start Load.

If loading is unsuccessful, correct the condition indicated by the Failure Code Readout per Section IV, and depress LOAD to reattempt the load operation.

- D. Depress ON-LINE. ON-LINE LED lights and the Readout continues to display the Unit Number.
- E. The Tape Drive is now ready to accept commands from the Host. The Drive can be taken Off-line manually by the operator pressing ON-LINE or by the Host issuing an Off-Line Command.

2.6.2 OPERATION NOTES

A. On-line Operations:

When the Drive is on line, the Readout displays the Unit Number whether or not the Drive is selected.

B. Load Operations:

1. If the Drive is unable to Load, the Readout will display a diagnostic message such as: "CHK HUB", "ABORTED", "REV REEL" etc., and the RWND/UNL LED will flash.
 - a. Pressing LOAD will start another Load attempt.
 - b. Pressing RWND/UNL will clear flashing LED and Error Message.
 - c. If nothing is done, after one minute, the Drive displays "UNIT X".
 - d. See NOTE under paragraph 2.5.3.1, Step C.
2. Pressing RWND/UNL while the Drive is Loading, aborts the Load Sequence.

C. Rewind Operations:

1. If the Drive is off line, pressing RWND/UNLD once causes the Drive to rewind tape to BOT.
2. If the Drive is off line, pressing RWND/UNL while the Drive is rewinding, or while positioned at BOT, will initiate an Unload Operation after the Drive has completed Rewind.

D. Recovering From Tape Running Off Reel:

The Drive has a built-in feature to prevent tape runaway: If a block of data is not encountered within 25 feet of tape motion before EOT, or 5 feet of tape motion after EOT, the Drive will normally stop tape motion. However, the 25-foot/5-foot limit feature can be defeated in the Set-Up Mode, or by continued Read Commands being received from the Host after EOT has been passed. Either of these conditions could result in tape being run completely off the Supply Reel. The following procedure is recommended to recover from this predicament.

1. The display will read TAPE END and the RWND/UNL LED will be flashing. Press the RWND/UNL switch and wait for the arms to retract.
2. Manually thread tape backwards through the tape path from the Take-up Reel to the Supply Reel. Refer to Figure 2-12.
2. Wrap tape around the Supply Reel in a **counterclockwise** direction.
3. Manually rotate the Supply Reel **counterclockwise** until the EOT Tab is on the Supply Reel.
4. Press LOAD. Tension Arms will tension tape and tape will rewind back to Load Point.

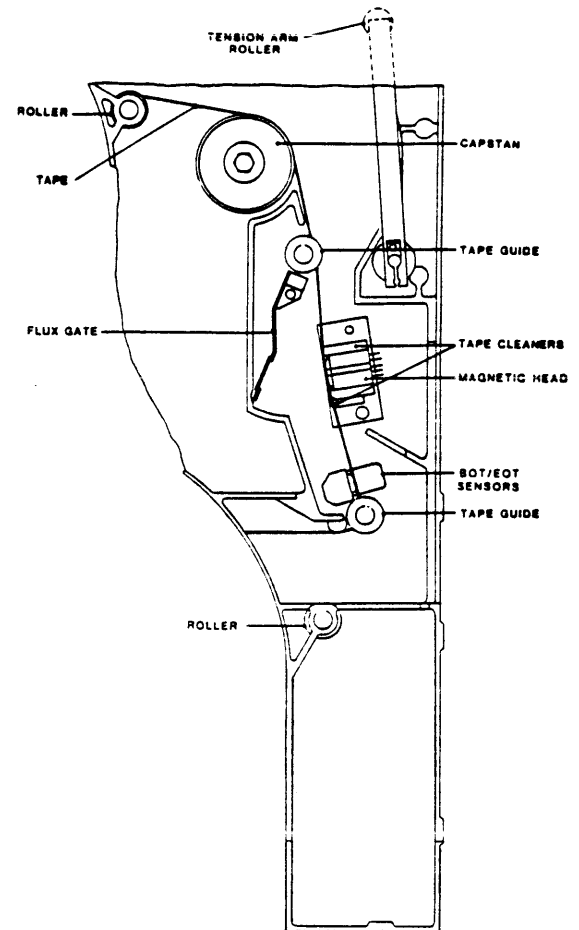

Figure 2-12. Tape Threading

E. Manually Locking/Unlocking Supply Reel on Supply Reel Hub:

The Supply Reel Hub normally automatically locks the Supply Reel in place during the loading sequence. However, the Supply Reel can be manually locked in place using the Manual Reel Locking Lever located just inside the Tape Access Door (illustrated in Section VI, Figure 6-1).

To manually install (lock) a Supply Reel onto the Hub:

1. Open the Tape Access Door and the Top Cover of the Drive.
2. Place a Supply Reel onto the Supply Reel Hub.
3. Press the Manual Reel Locking Lever inward (toward the rear of the Drive) while slowly turning the Supply Reel and Hub clockwise until the Reel Locking Fingers of the Hub extend outward and lock the Reel in place.

To manually release the Supply Reel from the Hub:

1. Press the Manual Reel Locking Lever inward while slowly turning the Supply Reel and Hub counterclockwise until the Reel Locking Fingers of the Hub retract and release the Supply Reel.

F. Default Parameters

The Tape Drive is factory set to the following parameters. These parameters can be changed as desired as described in Section IV, Diagnostics.

<u>Parameter</u>	<u>Default Setting</u>	<u>Description</u>	<u>Other Options</u>
UNIT NUM	UNIT 0	Drive Unit Number (Address)	1 thru 7
DENS SEL	NORMAL	Enables manual density selection	REMOTE ONLY
DFLT DEN	1600 REM	Default Density, 1600 cpi Remote, Host selectable	1600 800, 800 REM 3200, 3200 REM
SPEED	HOST SEL	Tape Speed, Host selects	AUTO SPEED 50 ips, 100 ips
TIME OUT	25 FT ON	Drive times out if data not detected within 25 feet of tape run.	25 FT OFF
SECURITY	ENABLED	Host can command tape erasure from the tape's present position to a point 3 feet past End Of Tape.	DISABLED
PARITY	IGNORE	Drive does not check write Data Parity	CHECK
LONG GAP	1.2 INCH	Long Gap Command from Host causes Interblock Gap of 1.2 inches when streaming at 100 ips.	2.5
NRZI CCG	ENABLED	The Drive sends NRZI CRC and LRC Characters to Host following each data block.	DISABLED
CLR FBSY	POSTREPO	The Drive clears FBSY after repositioning, following a 100 ips Command	WITH DBY
IFEN	NORMAL	Formatter Enable Signal is normal (not inverted)	INVERT
DENS OUT*	NRZ	Industry standard density status	CODED
FMK GAPS	EXTENDED	4 inch gap between data block and file mark, in all densities.	NOMINAL

NOTE: For a full definition of parameters, see Section IV, DIAGNOSTICS.

*Refer to 1.4.2.18 for definition of CODED and NRZ.

SECTION III
FUNCTIONAL DESCRIPTION

SECTION III

FUNCTIONAL DESCRIPTION

3.0 GENERAL

This section describes general operation of the major components of the 9600B/9650B Drive.

3.1 SYSTEM DESCRIPTION

3.1.1 OVERVIEW

The 9600B/9650B Drive is organized around a Motherboard mounted flat in the bottom of the chassis at the rear of the unit. The Motherboard interconnects the four major circuit cards: The Formatter Board, Read Analog Board, and Read/Write Digital Board, which slide into a card cage accessible at the rear of the unit, and the Drive Electronics Board, which mounts flat in the chassis underneath the deck plate.

The Servo Amplifier Assembly is located on the chassis under the deck plate, adjacent to the Power Supply Assembly and the Drive Electronics Board. The Position Sensors Board and the Interconnect Board mount directly to the Deck Plate, and the Read Preamp Board is connected directly to the Read Head on the Deck Plate. The Operator Control Panel is located on the front of the Drive.

3.1.2 FORMATTER BOARD

Along the top edge of the Formatter Board, there are two 50-pin card edge connectors. Cables which attach to these connectors convey Commands, Data, and Status Information between the Drive and the Host. Connector signals and pin assignments are defined by Industry Interface Standard.

The Host Interface includes buffers and line receivers to interface with the host, decoders to accomplish unit selection, and a latch to hold command bytes.

Read/Write Compare Buffer: The Read/Write Compare Buffer is a 1k byte RAM memory with address counters to configure it as a circular data file. This Buffer accomplishes a byte-by-byte data comparison of Write and Read Data during Read-After-Write Operations.

The Read/Write Compare Buffer momentarily stores Host Write Data that is currently being written to tape. The Drive, performing a Read After Write Operation, immediately reads the written data and sends it back to the Compare Buffer where it is compared with the stored Write Data. A favorable comparison allows the Drive to continue writing Data to tape. A comparison error is reported to the Host on the HER Status Lines along with Read data on the Read Data Lines.

The Buffer also serves during Data Diagnostics Operations as a data source for the Write Process, and evaluates the success of the Read Process.

Formatter Control Processor: The Formatter Control Processor is a micro-computer and its associated support devices. This device receives Commands from the Host Interface and schedules them for execution, sending them to the other functional units of the Drive via the Bus Interface and Formatter Control Bus.

The Formatter Control Processor tracks tape position by monitoring Counters in the Tachometer Interface that increment or decrement with the arrival of Tachometer Pulses from the Capstan Tachometer.

Figure 3-1. Model 9600B/9650B Tape Drive General Block Diagram

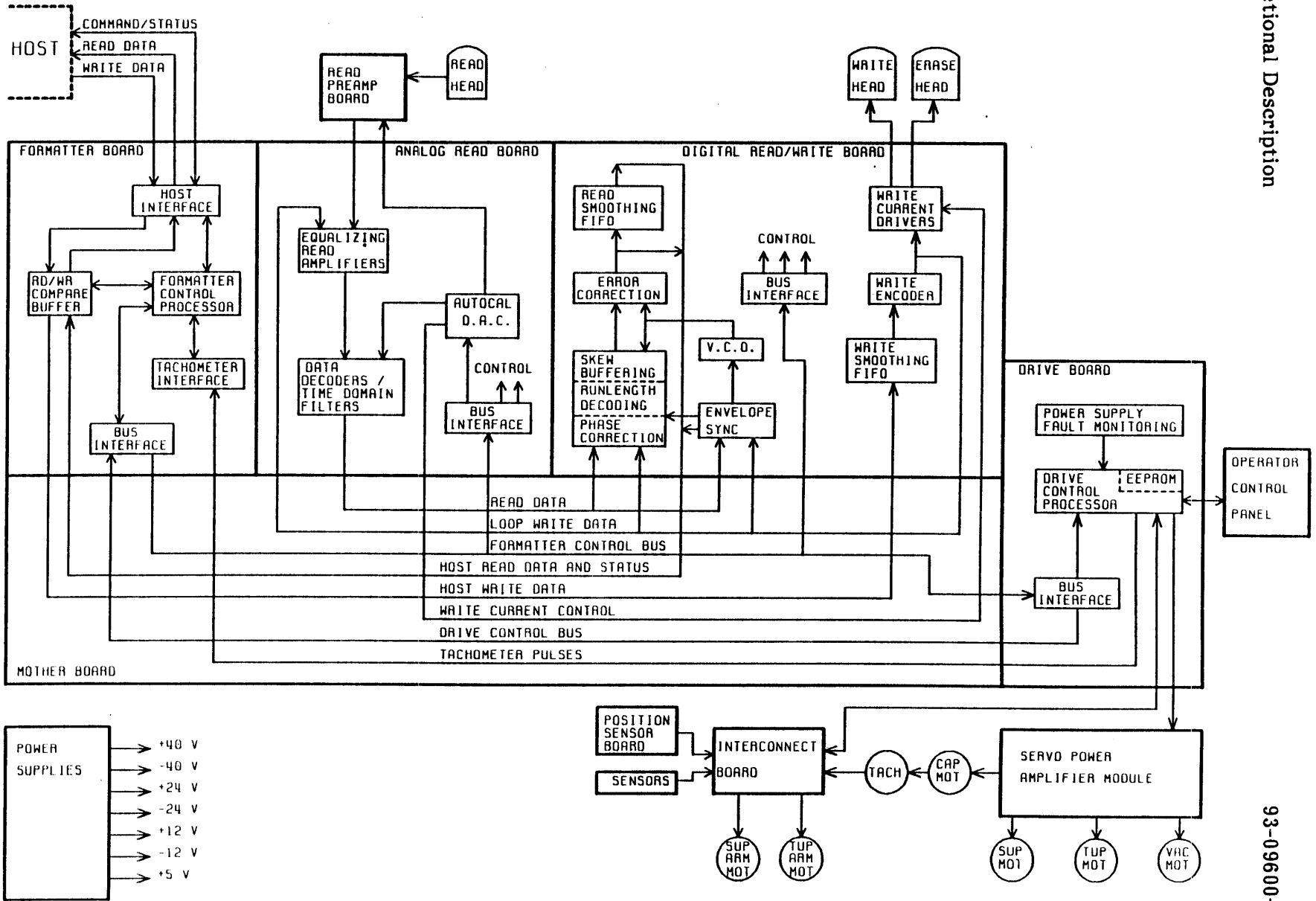

Formatter Control Bus: The Formatter Control Bus consists of the 8-line Formatter Data Bus (FDB), the 7-line Formatter Select Bus (FSEL), and 5 handshaking lines. The Formatter Control Bus conveys Commands and Status to all major components of the Drive. The status of the Select lines determine distribution of Control and Status signals. The destination module signals acceptance or rejection of Control Signals by issuing an Acknowledge or Busy Signal.

The Formatter Control Bus also conveys all commands initiated by the Drive or Operator Control Panel to the Formatter to completely control the Read and Write Sections of the Drive. Note that the Formatter communicates with the Operator Control Panel via the Drive Electronics Board.

3.1.3 READ PREAMP BOARD

The Read Preamp Board contains a high-gain, low-noise preamplifier with electronic gain control, for each of the nine channels. For excellent noise performance, it is located very close to the magnetic Read Head. The Preamp connects to the Read Analog Board through a ribbon cable that passes under the deck plate.

3.1.4 READ ANALOG BOARD

Signals from the Read Preamp are processed by the Equalizing Read Amplifiers, which include CMOS switches that select the optimum equalization network for each speed and density.

Data Decoders: After equalization, the Read Signal is processed in the Data Decoders that include a time domain filter, which rejects any transitions which are too close together in time. This improves noise margins. The Data Decoders also verify threshold, squelching the Read Data if its amplitude falls below the threshold for several cell periods.

Digital-to-Analog Converter (DAC): The DAC is a multiplexed 8-bit digital-to-analog convertor with a small RAM used to hold digital calibration values. The DAC generates Gain control signals for the Read Preamp, and threshold values for the data detectors. Settings for the DAC come from the Control Processor in the Formatter Board via the Formatter Data Bus. These settings are written to the Read Analog Board at Power Up or can be entered manually from the Front Panel.

The DAC also generates values that control Write Current generated by Write Current Drivers in the Read/Write Digital Board)

3.1.5 READ/WRITE DIGITAL BOARD

The Read/Write Digital Board Decodes Read Data, encodes Write Data, and performs Error Correction as required.

Envelope Synchronization: Read Data from the Data Decoders in the Read Analog Board are applied to the envelope/synchronization circuit where file marks and other special blocks are recognized, and envelopes (signal-presence) are provided for the Processor in the Formatter Board to use during Calibration.

Voltage Controlled Oscillator (VCO): At the beginning of each data block, the Envelope Synchronization provides a series of sync signals which control the Voltage Controlled Oscillator (VCO) in a Phase-Lock-Loop (PLL) Synchronization Acquisition Process. Based on available envelope information, the Envelope Synchronization selects one data track to use for synchronizing the Phase Lock Loop.

The PLL is a feedback system which maintains the Voltage-Controlled Oscillator as an internal clock in synchronization with the arriving data stream. If the data stream speeds up or slows down because of variations in tape speed, the VCO also change its frequency to maintain synchronization with the data. During the Interblock Gap, the PLL is synchronized to a crystal controlled clock known as the Gaplock.

Phase Correction: One VCO controls the decoding process for all 9 tracks. However, individual tracks may vary slightly in phase due to a phenomenon known as "dynamic skew." To correct for this problem, each track is provided with a phase-corrector circuit, which is a first-order digital phase-lock loop of very low bandwidth, synchronized with the VCO. The phase correctors also provide additional rejection for low-rate changes in tape speed.

Runlength Decoding: For the PE codes, the data transitions must be separated from the phase transitions. Also, the special control characters marking the beginning and end of each block must be recognized. These requirements are accomplished by the Runlength Decoding Circuitry.

Skew Buffering: Data from the various tracks may arrive from the Read Head at different times. The resulting skew may be as much as several character times. To bring the data from the nine tracks into correct time phase, each track is provided with a First-In, First-Out (FIFO) buffer. Track Data flows into the FIFO Buffers asynchronously, and flows out from the FIFOs synchronously and in parallel.

Error Correction: Using PE format, data lost to tape defects may be restored during the decoding process. The Drive can recover one bad track of PE formatted data. The NRZI format also include redundant checksum bytes, which may be used to verify that the data has been received correctly.

Read Smoothing FIFO: From Error Correction, Read Data flows through a small transfer rate matching FIFO, from where it is multiplexed with Status and Envelope information and sent through the Motherboard, to the Formatter Board.

Write Processing: The Read/Write Digital Board includes the Write Data Processing System. Write Data from the Read/Write Compare Buffer in the Formatter Board is applied to the **Write Smoothing FIFO**, from where it is applied to the Write Encoder. The **Write Encoder** prepares the Write Data for application to the Write Current Drivers, and generates the File Mark and special blocks, for all densities. The encoded Write Data may also be passed to the Phase Correction and Envelope Synchronization Circuitry, or directly to the Equalizing Read Amplifiers in the Read Analog Board, for diagnostic purposes. The **Write Current Drivers** consist of discrete transistor current sources, which apply Write Data or Erase Power to Write Head or Erase Head.

3.1.6 DRIVE ELECTRONICS BOARD

The Drive Electronics Board controls all electro-mechanical tape handling devices in the unit, including the Capstan, Supply and Take-up Reel Motors, the Servo Systems, the Take-up and Supply Buffer Arms, and the Autoload Mechanisms, including the Vacuum Blower, Supply Reel Hub Locking Mechanism, and various monitoring sensors. The Drive Electronics Board also interfaces between the Operator Control Panel and the Motherboard.

Drive Control Processor: To control the above-mentioned devices, the Drive Electronics Board includes the Drive Control Processor, which is a microcomputer with its support circuits, and an EEPROM for non-volatile data storage.

The Drive Control Processor receives commands from the Formatter via the Formatter Control Bus, and sends commands and data to the Formatter via the Drive Control Bus. The Drive Control Bus is a unidirectional bus consisting of 8 data lines, one strobe line, and two select lines.

The Drive Electronics Board includes circuitry to monitor the Tachometer and establish the correct tape speed, and the Power Supply Fault Monitor to gracefully shut down the Tape Transport if a fault occurs.

3.1.7 SERVO POWER AMPLIFIER

The Servo Power Amplifier consists of three sets of Power Drivers that drive the Supply Reel Motor, Take-up Reel Motor and Capstan Motor. A balancing circuit interacts between the positive and negative power sources, restoring any imbalances that occur by the operation of the three Power Drivers. When enabled by the Drive Control Processor, the feedback loops in the Reel Motor Servo cause the tape reels to move so as to maintain the Tape Buffer Arms in their linear operating region, regardless of tape motion caused by the Capstan. Meanwhile, the Capstan Motor Servo maintains tape speed at any value requested by the Drive Control Processor.

3.1.8 OPERATOR CONTROL PANEL

The Operator Control Panel includes an alphanumeric display that conveys status messages, control and diagnostics options to the operator. The Control Panel also includes an array of switches and LED indicators to operate the unit.

3.1.9 INTERCONNECT BOARD

The interconnect board consolidates wiring that connects the Drive Electronics Board to the various sensors, motors and solenoids mounted on the Deck Plate.

3.1.10 POSITION SENSORS BOARD

The Position Sensors Board monitors capacitive sensors mounted on the shafts of the Supply and Take-up Arms. These sensors are automatically calibrated each time power is turned on.

3.1.11 POWER SUPPLIES

The Power Supplies are mounted on the chassis under the Deckplate. Unregulated +/-40 Volt and +/-24 Volt Supplies apply power to the servos, and a switching 5-Volt Regulator supplies logic power for the Drive. Power supply fault monitoring is provided on the Drive Electronics Board.

**SECTION IV
DIAGNOSTICS**

SECTION IV DIAGNOSTICS

4.0 GENERAL

The Model 9600B/9650B Tape Drive incorporates extensive built-in Self-Test and Front-Panel Diagnostics providing tests for maintenance and troubleshooting aids. Self-Test Diagnostics occur automatically during Power Up, displaying appropriate failure codes if failure occurs. Front Panel Diagnostics are manually-controlled operations that exercise the Tape Drive, displaying appropriate readouts to indicate Drive condition.

4.1 CONTROLS AND INDICATORS

Controls and Indicators used in Diagnostics and Calibration Modes are listed and described in Section II, Figure 2-10.

4.2 TROUBLESHOOTING

Troubleshooting the Tape Drive consists of using diagnostics, and self-tests to diagnose mechanical, electromechanical, and electronic malfunctions.

Diagnostics include firmware-controlled tests and exercises that can be initiated by the Operator from the Drive Front Panel. The Digital Display on the Front Panel provides diagnostic readouts.

Self-Tests occur with each Power Up, or can be manually initiated using the Diagnostics Menu. Self-Tests include failure codes and diagnostic readouts on the Front Panel Digital Display.

4.2.1 ACCESSING THE DRIVE FOR TROUBLESHOOTING

CAUTION: A solidly grounded ESD Wrist Strap should be worn whenever touching or handling any Circuit Board or other electronic assembly in the Drive.

WARNING: Dangerous AC voltage exist in and about the Voltage Selector, the EMI Filter, the Power Transformer, Fan, and the Power Switch on the Front Panel. ALWAYS UNPLUG THE AC LINE CORD BEFORE WORKING IN THESE AREAS. (See Schematic Diagram 7109 (sheet 2) for illustration of AC voltage distribution.

The Drive includes personnel safety interlocks that operate when the Tape Access Door or Top Dust Cover is opened. To operate the Drive for troubleshooting, the technician must defeat the Interlocks as follows:

- A. With AC power ON, unload tape (as applicable).
- B. Raise the Deck assembly to Maintenance Position per 5.2.2.
- C. On the Drive Electronics Board, move the Diagnostics Jumper (ST4 - Ref Figure 5-31) from its present position as follows:
 1. If original position is EN: press and hold ENTER, and move from EN to DIS.
If original position is DIS: press and hold ENTER, and move from DIS to EN to DIS.
 2. If you intend to test, calibrate, or operate the Drive via Diagnostics Pushbuttons, move the Jumper from DIS to EN (Do not press ENTER).
 3. From Step 1 you have one minute to lower the Deck Assembly and load tape. If tape has not been loaded within one minute, repeat Step C.
- D. Display flashes "NO INTLK". Press DIAG to start Diagnostics.
- E. To reactivate the Interlock, unload tape.

4.3 POWER UP

Upon Power Up, and without a reel of tape inserted, the Readout normally displays: TESTING, for approximately 7 seconds. If TESTING continues to be displayed, this indicates that communication between Formatter and Drive is disrupted and no further testing can be accomplished. There is a problem in the Formatter or the interface between Formatter and Drive. Assuming that communication between Formatter and Drive is obtained, the Drive performs the Self-Tests described below. In addition to the Failure Codes, The Drive can display Failures in the form of words or abbreviations. Tables 4-1 and 4-2 list and describe the Failures represented by this type of display, and also indicate the possible causes of failure. If a failure should occur during Power Up, press REWIND/UNLOAD. This clears the error and permits the operator to load tape and perform diagnostics.

Each Power Up Self-Test exercises the following areas of the Drive:

- A. Drive Electronics:
 1. Power Supply
 2. Drive Electronics PCBA
 3. Front Panel
 4. Servo System including Reel and Capstan Motors.
- B. Formatter and Read/Write Electronics:
 1. Formatter Board
 2. Write/Read Board
 3. Read Analog Board

4.3.1 DRIVE ELECTRONICS FAILURE DISPLAYS

Table 4-1 lists failure displays

Table 4-1. Drive Electronics Failure Displays

DISPLAY	FAULT CONDITION/POSSIBLE FAILURE
TESTING	Formatter not communicating with the Drive: Diagnostics hangup: Formatter Board 8951, Drive Electronics Board 8952.
FMT ERR? and flash REW	Formatter Error (Formatter Timeout): Formatter Section has failed to interrogate Drive Electronics; or the Formatter has failed to send its Identification (ID) after request from the Drive Electronics. Check Formatter Board 8951.
TAK ARM?	Take-up Arm fails to calibrate.
SUP ARM?	Supply Arm fails to calibrate.
CAPSTAN?	No Tachometer Voltage. Check Capstan Motor, Capstan Power Amplifier, and Tachometer.
T MOTOR?	Take-up Reel Motor not running: Servo Preamplifier 7147, Servo Amplifier 7111, Drive Electronics Board 8952, Take-up Reel Motor.

Table 4-1. Drive Electronics Failure Displays (Continued)

DISPLAY	FAULT CONDITION/POSSIBLE FAILURE
S MOTOR?	Supply Reel Motor not running: Servo Preamplifier 7147, Servo Amplifier 7111, Drive Electronics Board 8952, Supply Reel Motor.
ROM ?	Drive Electronics Program PROM Checksum Error: Non-zero checksum detected.
EEPROM ? and Flash REW	Checksum Error: Non-zero checksum detected. Press RWND/UNL. The Drive will compute a new checksum and attempt to write it into the EEPROM. Check Drive Electronics Board 8952
+12V ?	Voltage below +10V
+40V ?	Voltage below +30V
-12V ?	Voltage above -7V
-40V ?	Voltage above -29V
FAIL XXX	(XXX refers to Failure Code - See Table 4-2)
ARM CAL?	The arm calibration values are uninitialized, i.e. a new EEPROM has been installed on the Drive Electronics Board or the EEPROM data has been corrupted.
ARM JPR?	Jumper W1 on the Position Sensor PCBA 9069 is missing.
BAD SCSI	SCSI Interface Board has failed the power-up test.
RETRACT?	One of the Retract Assemblies failed during the power-on testing.
DRV FAIL	Reset Circuit or Watch Dog Timer Circuit failed on the Drive Electronics Board.

**Check applicable
Power Supply
and Regulator**

4.3.2 FORMATTER FAILURE CODES

Table 4-2 lists the Failure Codes that could display during Power Up, indicating probable causes of failure. Note that Failure Codes 150 thru 159 include the option of obtaining a second Failure Code which indicates specific problems. If a Failure Code between 150 and 159 occurs, to obtain the second Failure Code, press DENSITY.

NOTE: the Failure Code is preceded by the word: FAIL.

Table 4-2. Power Up Failure Codes

CODE	DESCRIPTION	PROBABLE FAILURE	
128	External RAM Data Error	Compare RAM Formatter 8951	
129	External RAM Addressing Error		
131	No RBSY for Read Amp Gain Values	Read Analog Board 9017	
132	Wrong Formatter Bd for 9600B/9650B	Formatter Board 8951	
133	Wrong Analog Board for 9600B/9650B	Read Analog Board 9017	
134	Wrong Digital Board for 9600B/9650B	Read Digital Board 9060	
136	Address Counter Failure	Formatter Board 8951	
140	Auto Adjust Ranging Error	Read Analog Board 9017	
141	Dead Track found in Auto Adjust		
142	Over Range Signal in Auto Adjust		
150	No RBSY in Loop RAW Test	Press DENSITY Pushbutton for Second Code listed below:	
151	No WBSY in Loop RAW Test		
152	Time-out on WBSY in Loop RAW Test		
153	Time-out on RBSY in Loop RAW Test		
154	WBSY ended too soon in Loop RAW Test		
155	Hard Error in Loop RAW Test		
156	Corrected Error in Loop RAW Test		
157	Compare Error in Loop RAW Test		
158	File mark during Loop RAW Test		
159	Block Size Error in Loop RAW Test		
ITEM	SECOND CODE	DESCRIPTION	PROBABLE FAILURE
1	D-50 NRZ	Loop Write to Read Digital, 50 ips NRZI	Read Digital Board 9060
2	D-100NRZ	Loop Write to Read Digital, 100 ips NRZI	
3	D-50 PE	Loop Write to Read Digital, 50 ips PE	
4	D-100 PE	Loop Write to Read Digital, 100 ips PE	
5	D-50 DPE	Loop Write to Read Digital, 50 ips DDPE	
6	D-100DPE	Loop Write to Read Digital, 100 ips DDPE	
7	A-100 PE	Loop Write to Read Analog, 100 ips PE	Read Analog 9017
8	A-50 DPE	Loop Write to Read Analog, 50 ips DPE	
9	A-100DPE	Loop Write to Read Analog, 100 ips DPE	
Legend:			
RBSY = Read Busy Signal		RAW = Read After Write	
WBSY = Write Busy Signal			

4.3.3 FORMATTER POWER UP SELF-TEST DESCRIPTIONS

The Drive displays TESTING during the Power Up Tests, and UNIT X when the testing is complete. If the Drive fails to Power Up, it displays either the failed module or a failure code. Power Up Self-Tests are described as follows:

- a. **Micro-processor Sanity Check:**
Verify operation of the Microprocessor.
- b. **Microprocessor RAM Check:**
Verify operation of 8031 internal RAM
- c. **External RAM Check, Data Pattern 55H:** Failure Code 128.
Verify operation of External RAM with Data Pattern 55H.
- d. **External RAM Check, Data Pattern AAH:** Failure Code 128
Verify operation of External RAM with Data Pattern AAH.
- e. **External RAM Check, Addressing:** Failure Code 129
Verify addressing capability of External RAM.
- f. **ID The Formatter:** Failure Codes 132, 133, 134
Verify that the Formatter, Read Analog, and Write/Read Boards are the proper type for 9600B/9650B operation.
- g. **Address Counter Check:** Failure Code 136
Verify the operation of the data compare RAM address counter.
- h. **Send Test Amp Gain Values to Analog Board:** Failure Code 131
Verify operation of Read Analog Board.
- i. **Loop Write to Read Digital:** Failure Codes 150-159
Run data through the Write/Read Digital Board, looping it from the output of the Write Section back into the Read Section, and verify proper operation at all speeds and densities.
- j. **Loop Write to Read Analog:** Failure Code 150-159
Loop data, from the output of the Write Section of the Write/Read Board to the input of the Read Analog Board, and verify proper operation.

4.4 LOADING & CALIBRATION FAILURE DISPLAY:

The 9600B/9650B also includes automatic diagnostics that can detect loading failures, giving appropriate displays to indicate failures and their possible causes. Table 4-3 lists and describes the displays and related Fault Condition, and Possible Failures that could occur during Loading. After successfully completing Power Up, load a reel of tape into the Drive. If there is a loading failure, one of the displays listed in Table 4-3 will appear.

Table 4-3. Loading and Calibration Failures

DISPLAY	FAULT CONDITION/POSSIBLE FAILURE
1. CLOSE/DOOR COVER?	Door Interlock Circuit: (Drive cannot load) Tape Access Door open, Door Switch, Drive Electronics Board 8952, Interconnect Board 7228.
2. NO BOT?	No BOT Marker detected: Tape Marker missing from tape, Tape Leader too short, Faulty BOT Sensor, Drive Electronics Board 8952, Interconnect Board 7228.
3. ABORTED	Automatic Load aborted: No vacuum, Air leak in tape path, Drive Electronics Board 8952, Servo Boards 7111, 7147, Position Sensors, tape sticking (ref 2.5.3.2, Step C).
4. REV REEL	Reverse Reel - Reel upside down.
5. PLC REEL	Place Reel. Tape Reel not installed.
6. CHK SLND	Check Hub Lock Solenoid - not locking: Hub Lock Solenoid defective or needs adjustment, Drive Electronics Board 8952, Interconnect Board 7228.
7. CHK HUB	Check Hub - Supply Reel not detected: Reel-In-Place Tab Adjustment, Reel-In-Place Sensor, Drive Electronics Board 8952, Interconnect Board 7228.
8. BKN TAPE	Broken Tape - Tape not detected: Broken Tape, No EOT Marker, EOT Sensor, Interconnect Board 7228, Drive Electronics Board 8952.
9. TAK ARM?	Take-up Arm not operating correctly: Take-up Arm Position Sensors (Check with Arm relaxed), Position Sensor Board 9069, Interconnect Board 7228.
10. SUP ARM?	Supply Arm not operating correctly: Supply Arm Position Sensors (Check with Arm relaxed), Position Sensor Board 9069, Interconnect Board 7228.
11. ARM OFF?	A Tension Arm traveled beyond the preset limits: Recalibrate Tension Arms.

Table 4-3. Loading and Calibration Failures (Continued)

DISPLAY	FAULT CONDITION/POSSIBLE FAILURE
12. A-T CAL?	The Auto-Tune calibration values are invalid: The calibration must be performed.
13. CHK ARMS	The Drive Electronics PCBA 8952 has detected a gross error in the arm output voltage: Position Sensor PCBA 9069 failure; Tension Arm out of adjustment.
14. CHK CAPS	Tape motion fault, i.e. speed error, ramp timeout, loss of tach pulses: Capstan Motor/Tach; Drive Electronics PCBA 8952; Servo Boards 7111, 7147.
15. CHK DRV	The capstan gain is out of range during the auto-tune calibration: Drive Electronics PCBA 8952.
16. CHK TAPE	This message appears after a tape loading operation has aborted and the operator has pressed the flashing RWD/ONL switch. The operator should open the tape access door to reset the "CHK TAPE" message and examine the tape path for any unusual conditions.
17. JUMPER?	The Calibration Jumper (ST3 on the Drive Electronics PCBA 8952) is in the disabled position while the operator is attempting to perform certain calibration operations: ST3 must be in the enabled position.
18. RET MOT?	One of the Tension Arm Retract Assemblies failed during the loading process.
19. TIC-SENS	Tape in channel sensor or emitter failed.
20. CANT WR	The Write Enable Ring is not being detected during Calibration Data Test and Data Diag.
21. TAPE END	Failed to detect EOT and tape runs off the Supply Reel: Tape marker missing from tape; tape trailer too short; faulty EOT Sensor; Interconnect PCBA or Drive Electronics failed.

4.5 FRONT PANEL DIAGNOSTICS

NOTE: To perform Diagnostics, Diagnostics Jumper ST4 (on Drive Electronics Board 8952) must be in ENABLE Position per Figure 5-31.

Diagnostics are divided into six major sections represented by Displays as indicated below:

<u>Chart</u>	<u>Section</u>	<u>Display</u>	<u>Chart</u>	<u>Section</u>	<u>Display</u>
A	Self-Test	SELFTEST	D	Set Up	SET UP
B	Motion	MOTION	E	Calibration	CAL
C	Drive Adjustment	DRV ADJ	F	Data diagnostics	DATADIAG

Each section, when accessed, displays its own Menu which further divides into submenus. Figure 4-1 illustrates, and the following subparagraphs describe accessing the major diagnostic sections, their Menus and Submenus.

Note that although Set Up and Calibration are contained in the Diagnostics Menu, they are not Diagnostic Functions. They are for setting up the Drive for operation and for calibrating as required.

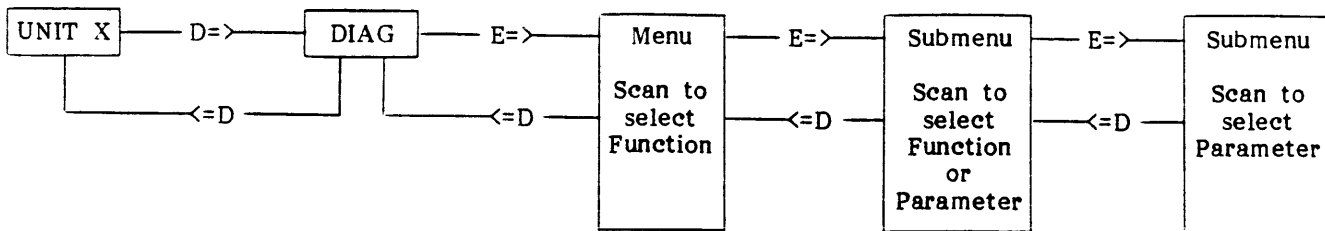

NOTE: D=> indicates press DIAG and proceed to the right.
 <=D indicates press DIAG and proceed to the left.
 E=> indicates press ENTER and proceed to the right.

Figure 4-1. Diagnostics Menu Dynamics (Simplified)

4.5.1 DIAGNOSTICS MENU

Table 4-4 illustrates the overall Diagnostics Menu structure. Each indent represents a Submenu accessible from the Main Menu, usually by pressing ENTER. Pressing SCAN accesses the next lower item in any Menu or Submenu.

Table 4-4. Diagnostics Menu Structure

<p>A. SELFTEST</p> <p>1. Power Up Test</p> <p>2. Data Test</p>		<p>E. CALIBRATE Functions/Parameters (2)</p> <p>1. Auto</p> <p> a. All</p> <p> 1) Confirm? (3)</p>
<p>B. MOTION Parameters (1)</p> <p>1. 50 FWD 8. 100 FSS</p> <p>2. 50 REV 9. 100 RSS</p> <p>3. 50 FSS 10. 100FRF</p> <p>4. 50 RSS 11. 50/100 F</p> <p>5. 50 FRF 12. 50/100 R</p> <p>6. 100 FWD 13. BURN IN</p> <p>7. 100 REV</p>		<p>E. CALIBRATE (Continued)</p> <p> b. 800</p> <p> c. 1600 50 ips (4)</p> <p> d. 3200 100 ips</p> <p>2. Manual</p> <p> a. 800</p> <p> b. 1600 50 ips (4)</p> <p> c. 3200 100 ips</p>
<p>C. DRV ADJ Functions: (2)</p> <p>1. Buffer Arms</p> <p> a. Takeup</p> <p> b. Supply</p> <p>2. Hub Sensor</p> <p> a. Not In</p> <p> b. In Place (Monitor)</p> <p>3. RL Servo</p>		<p>F. DATA DIAGNOSTICS (2)</p> <p>1. Mode (Test Options)</p> <p> a. On Error:</p> <p> 1) Continue</p> <p> 2) Stop</p> <p> b. At EOT:</p> <p> 1) Rewind</p> <p> 2) Stop</p> <p> c. Block Size:</p> <p> 1) 4</p> <p> 2) 256</p> <p> 3) 513</p> <p> 4) 1024</p> <p> d. Data:</p> <p> 1) All Ones</p> <p> 2) All zeros</p> <p> 3) Increment</p> <p> 4) Random</p> <p> 5) Alternate 00 - FF</p> <p> e. Speed:</p> <p> 1) 50 ips</p> <p> 2) 100 ips</p> <p> f. Re-int:</p> <p> 1) Stream</p> <p> 2) Start/Stop</p> <p> 3) Single</p>
<p>D. SET UP Functions/Parameters (2)</p> <p>1. Unit Number:</p> <p> a. Unit 0 thru Unit 7</p> <p>2. Density Selection</p> <p> a. Normal</p> <p> b. Remote Only</p> <p>3. Default Density:</p> <p> a. 800</p> <p> b. 800 Remote</p> <p> c. 1600</p> <p> d. 1600 Remote</p> <p> e. 3200</p> <p> f. 3200 Remote</p> <p>4. Speeds:</p> <p> a. Host Select</p> <p> b. Auto</p> <p> c. 50 ips</p> <p> d. 100 ips</p> <p>5. Timeout:</p> <p> a. 25 Ft ON</p> <p> b. 25 Ft Off</p> <p>6. Security:</p> <p> a. Enabled</p> <p> b. Disabled</p> <p>7. Parity:</p> <p> a. Check</p> <p> b. Ignore</p> <p>8. Long Gap:</p> <p> a. 0.45 INCH</p> <p> b. 0.80 INCH</p> <p> c. 1.20 INCH</p> <p> d. 2.50 INCH</p> <p>9. NRZI CCG</p> <p> a. ENABLED</p> <p> b. DISABLED</p> <p>10. CLR FBSY</p> <p> a. WITH DBY</p> <p> b. POSTREPO</p> <p>11. IFEN</p> <p> a. NORMAL</p> <p> b. INVERT</p> <p>12. DENSITY OUTPUT</p> <p> a. Coded</p> <p> b. NRZ Only</p>		<p>2. Commands (5)</p> <p> a. Loop Dig</p> <p> b. Loop Alg</p> <p> c. Write</p> <p> d. Wrt W/RE</p> <p> e. Read</p> <p> f. Read Reverse</p> <p> g. Read/RR</p> <p> h. FMK Test</p> <p> i. WRT/WFMK</p> <p> i. WR/RR/RD</p> <p>3. Errors (Display) (6)</p> <p> a. EIC(0-7,P) xxx (7)</p> <p> b. WPAR xxx (Write Parity Error)</p> <p> c. CMP xxx. (Compare Error)</p> <p> d. HER xxx (Hard Error)</p> <p> e. STE xxx Single-Track Error (Corrected)</p> <p> f. FMK xxx (Filemark Error)</p>

Note:

- (1) Press ENTER to start motion.
- (2) Press ENTER to enter parameter.
- (3) Press ONLINE for yes, DIAG for no.
- (4) Pressing ENTER displays CONFIRM?
Press ONLINE for yes, DIAG for no.
- (5) Press START/STOP to start and stop
- (6) xxx = Quantity of Errors
- (7) Error in Channel

4.5.2 OPERATING PROCEDURE

Running the diagnostics consists essentially of pressing specified pushbuttons on the front panel and following the direction provided by messages on the front panel display.

After a successful Power Up Self-Test, begin diagnostics by pressing the DIAG pushbutton. The Readout displays DIAG, and the Drive is ready to enter the Diagnostic Mode of operation. Subsequently, pressing the ENTER pushbutton accesses the Main Menu.

Generally, as illustrated in Figure 4-1, (proceeding from left to right) the Operator accesses a particular Menu or Submenu by pressing the ENTER pushbutton. He returns to a previous Menu or Submenu by pressing the DIAG pushbutton. Repeatedly pressing DIAG exits from the Diagnostics Mode.

In any Menu, repeatedly pressing the SCAN pushbutton scrolls through functions or parameters in that Menu. Generally, pressing ENTER activates that function or parameter. In certain Submenus, activating the parameter is done by pressing START/STOP, LOAD or ONLINE - these variations are described as applicable in the following subparagraphs. Note that pressing ONLINE in Diagnostics Mode does not place the Drive on line with the Host.

4.5.2.1 ENTERING THE DIAGNOSTICS MODE

In Diagnostic Mode, repeatedly pressing SCAN displays the Diagnostic Functions. Pressing ENTER enables the function displayed. This sequence is illustrated by the following chart:

NOTE: Be sure Diagnostics Jumper is in ENABLE Position. Ref Figure 5-31.

General Chart: Entering the Diagnostics Mode

Step	ACTION (Press:)	DISPLAY	ACTION (Press:)	DISPLAY	ACTION
0		UNIT X			
1	DIAG	DIAG			Press ENTER to activate selected operation.
2			ENTER	SELFTEST	
4			SCAN	MOTION	
5			SCAN	DRV ADJ	
6			SCAN	SET UP	Press DIAG to exit from Menu.
7			SCAN	CAL	
8			SCAN	DATADIAG	

Having selected a diagnostic function by pressing ENTER, repeatedly pressing SCAN scrolls through the selected Functions Menus illustrated by the following charts.

4.5.2.2 SELF-TEST

The front-panel-controlled Self-Test enables the Operator to rerun the Power Up Self-Tests (par. 4.3) without turning off power, and also to run a Data Write/Read Test. Chart A illustrates accessing the two Self-Tests. The following subparagraphs describe the Tests.

Chart A. Doing The Self-Test

Step	ACTION (Press:)	DISPLAY	ACTION (Press:)	DISPLAY	ACTION
0	DIAG	SELFTEST			
1	ENTER	PWUPTEST	ENTER	CONFIRM?	Press ONLINE to run Test. Press DIAG to abort Test and exit from Diagnostics.
2	SCAN	DATATEST	ENTER	CONFIRM?	

NOTE: 1. Do not install tape when running PWUPTEST. If tape is loaded when ONLINE is pressed, the Readout displays LOADED, and the test is not run.

2. When PWUPTEST is done, if Drive passes Test, Drive exits from the Diagnostics Mode and displays UNIT X. When DATATEST is done, if Drive passes Test, Display indicates PASSED. If Drive fails either Test, Display indicates a Fail Code (Tables 4-2 and 4-3).

4.5.2.2.1 POWER UP SELF-TEST

The Power Up Self-Test consists of tests described in paragraph 4.3.3. To run this Test, unload tape (as applicable). Then with the Readout displaying UNIT X, press DIAG, then ENTER. Press ONLINE to run test, DIAG to abort and exit from Diagnostics.

4.5.2.2.2 DATA TEST

For Data Test, if tape is not at BOT, Drive rewinds tape to BOT, then selects NRZI Density and proceeds with the Data Test. Note that the Data Test includes the Loop Write to Read Test to confirm operation of the Digital and Analog Modules. This Test is also run in the Power Up Self-Test. Data Test consists of the following subtests in the order listed. The Subtest Event Number displays as TEST XX, where XX represents 01 thru 27. If a failure occurs, the Drive displays a Code per Table 4-5. Pressing DENSITY displays the Subtest Event Number.

The Drive Selects NRZI Density and after each complete series of Tests, selects a new Density in the following sequence: NRZI, PE, DDPE.

Subtest Event

- A. Write with Retries 2 Blocks at 50 ips in Streaming Mode.
 - 1. Set Mode to Streaming.
 - 2. Write with Retry one block.
 - 3. Write with Retry one block.
- B. Write with Retries 2 Blocks at 50 ips in Start/Stop Mode.
 - 4. Set Mode to Start/Stop.
 - 5. Write with Retry one block.
 - 6. Write with Retry one block.
- C. Write with Retries 2 Blocks at 100 ips in Start/Stop Mode.
 - 7. Write with Retry one block.
 - 8. Write with Retry one block.
- D. Write with Retries 2 Blocks at 100 ips in Streaming Mode.
 - 9. Set Mode to Streaming.
 - 10. Write with Retry one block.
 - 11. Write with Retry one block.
- E. Write 1 File mark at 50 ips.
 - 12. Write with Retry one File menus, activating the parameter mark.

- F. Read Reverse 1 Block at 100 ips. Check for File mark Status.
 - 13. Read Reverse on block.
 - 14. Check Status. Should be File mark and not BOT.

- G. Read Reverse 8 Blocks at 100 ips, Streaming Mode. Confirm that Drive does not reach BOT.
 - 15. Read Reverse one block.
 - 16. Read Reverse one block.
 - 17. Read Reverse one block.
 - 18. Read Reverse one block.
 - 19. Read Reverse one block.
 - 20. Read Reverse one block.
 - 21. Read Reverse one block.
 - 22. Read Reverse one block.

- H. Rewind
 - 23. Rewind.

- I. Read Forward 1 Block at 100 ips. Check proper ID Burst Detection.
 - 24. Set Mode to Start/Stop.
 - 25. Read Forward one Block.

- J. Read Forward 1 Block at 100 ips.
 - 26. Read Forward 1 Block.

- K. Read Forward 2 Block at 100 ips in Streaming Mode.
 - 27. Set Mode to Streaming.
 - 28. Read Forward one block.
 - 29. Read Forward one block.

- L. Read Forward 2 Block at 50 ips in Streaming Mode.
 - 30. Read Forward one Block.
 - 31. Read Forward one Block.

- M. Read Forward 2 Block at 50 ips in Start/Stop Mode.
 - 32. Set Mode to Start/stop.
 - 33. Read Forward one Block.
 - 34. Read Forward one Block.

- N. Read Forward 1 Block at 50 ips. Check for File mark Status.
 - 35. Read Forward one Block.
 - 36. Check Status. Should be File mark.

- O. Rewind.
 - 37. Rewind.

- P. Select next Density and go to Subtest A.

- NOTE:**
- 1. Possible Messages that could occur during or after the Data Test are:
 - DATATEST - Data Test is being performed.
 - CAN'T WR - Tape not loaded or Write Protected.
 - PASSED - Drive has passed all Tests.
 - 2. Data Block = 2048 Bytes, Random Data

Table 4-5. Data Test Failure Codes

CODE	SUBTEST EVENT ^	ORDER*	PROBABLE FAILURE \
131		1	9017 PCBA
		2	9060 PCBA
150 thru	Items 1 thru 8 (from Table 4-2)	1	9060 PCBA
		2	8951 PCBA
159	Items 9 thru 12 (from Table 4-2)	1	9017 PCBA
200	2, 3, 12 any other	1	9060 PCBA
		1	9017 PCBA
		2	9060 PCBA
201	Any	1	8951 PCBA
		2	9017 PCBA
202	19 Any other	1	8951 PCBA
		1	9017 PCBA
		2	9060 PCBA
203	Any	1	9017 PCBA
204	11 Any other	1	9060 PCBA
		1	8951 PCBA
205	2, 3, 25 Any other	1	8951 PCBA
		1	9017 PCBA
		2	9060 PCBA
206	Any	1	9017 PCBA
		2	9060 PCBA
CANT WR		1	Cable (P12) on 7228

NOTE: Meaning of Failure Codes:

Code	Meaning
200	Excessive Retries on Write Command
201	File mark Status not received when expected on Read Command
202	Hard Error reported on Read
203	Corrected Error reported on Read
204	Compare Error reported
205	Lost Position
206	ID Burst Detection problem

* Order of Probability: 1 = most probable

^ Press DENSITY to display the Subtest Event Number. Display for Subtest Event is: TEST XX, where XX represents the Event Number (listed in 4.5.2.2.2).

\ Further diagnostics information may be available in terms of Channel Error by accessing Data Diagnostics (paragraph 4.5.2.8) and scanning through the Errors Menu.

4.5.2.3 CONNECTOR OR CABLE FAILURES

Power Up, Loading, and Data tests can also indicate PCBA interconnection faults related to cables and PCBA connectors. These Tests and Failure Messages with associated possible Cable or Connector Failures are listed in Tables 4-6 and 4-7.

Table 4-6. Cable or Connector Faults

TEST	FAILURE MESSAGE	FAULTY CABLE OR CONNECTOR *
(Switch On)	CAPSTAN (immediate)	Connector J2 on 7147
Power Up	CAPSTAN	P1 on 7228 Bd P6 on 7228 Bd P1 on 7111 Bd
Power Up	TESTING	P2 on 7228 Bd P14 on 7228 Bd P17 on 7228 Bd
Loading	CAPSTAN	P3 on 7228 Bd
Loading	CLSE DOOR	P7 on 7228 Bd
Loading	CHK SLND	P8 on 7228 Bd
Loading	CHK ARMS	P4 on 7228 Bd
Loading	BOT ?	P9 on 7228 Bd
Loading	ABORTED	P10 on 7228 Bd P11 on 7228 Bd (P10 and P11 on 7228 reversed)
Loading	CHK HUB	P13 on 7228 Bd
Datatest	202, Subtest 25	P1 on 9060 Bd
Datatest	205, Subtest 2	P1 on 9060 Bd P1 on 9017 Bd P15 on 7228 Bd P16 on 7228 Bd
Datatest	CANT WR	P12 on 7228 Bd
<p>NOTE: For further information concerning a malfunction, access Data Diagnostics (par. 5.4.2.7) and scan through the Errors Menu.</p>		
		<p>NOTE: * Connector not properly seated or cabled open circuited.</p>

Table. 4-7. Printed Circuit Board Assemblies in Card Cage

TEST	FAILURE CODE	PCBA NOT PROPERLY SEATED
Power Up	133	9017
	134	9060
	FMTR ERR	8951
Datatest	131 + RWND/UNL LED flashes	9017
	150 + Subtest Item 1	9060
	FMTR ERR	8951

4.5.2.4 MOTION DIAGNOSTIC TESTS

In Motion Mode, the operator can check and adjust the tape path, and Check Motors and Servos. Perform Motion Diagnostics Tests as follows:

After autoloading a tape, press the DIAG pushbutton. The Readout will display DIAG. Pressing the ENTER pushbutton will cause the Readout to display SELFTEST. Press SCAN and the Readout displays MOTION. Again pressing ENTER accesses the Motion Parameters Submenu. This sequence of events is illustrated in Chart B. Table 4-8 defines abbreviations displayed in the Motion Tests.

Chart B. Selection of Motion Parameters

Step	ACTION (Press:)	DISPLAY	ACTION (Press:)	DISPLAY	ACTION
0		MOTION			
1	ENTER			50 FWD	
2			SCAN	50 REV	
3			SCAN	50 FSS	Press START/STOP
4			SCAN	50 RSS	to select and initiate
5			SCAN	50 FRF	the displayed Test.
6			SCAN	100 FWD	
7			SCAN	100 REV	Press START/STOP
8			SCAN	100 FSS	again to stop motion
9			SCAN	100 RSS	
10			SCAN	100 FRF	Press DIAG to exit
11			SCAN	50/100 F	from Menu.
12			SCAN	50/100 R	
13			SCAN	BURN IN	

Table 4-8. Motion Test Definitions

DISPLAY	DEFINITION	DISPLAY	DEFINITION
50 FWD	50 ips Forward	100 FSS	100 ips Forward Start/Stop
50 REV	50 ips Reverse	100 RSS	100 ips Reverse Start/stop
50 FSS	50 ips Start/Stop	100 FRF	100 ips Fwd/Rev/Fwd
50 RSS	50 ips Reverse Start/Stop	50/100 F	50/100 ips Alternate Forward
50 FRF	50 ips Fwd/Rev/Fwd	50/100 R	50/100 ips Alternate Reverse
100 FWD	100 ips Forward	BURN IN	Continuous testing in Forward direction with Rewind at EOT.
100 REV	100 ips Reverse		

4.5.2.5 DRIVE ADJUSTMENT TESTS

Enter the Drive Adjustment Diagnostic Mode by repeatedly, as necessary, pressing DIAG until the Readout displays DIAG. Then press ENTER and SCAN until the Readout displays DRV ADJ. Chart C illustrates accessing the Submenus of the Drive Adjustment Mode.

Buffer Arm Test. Use the Buffer Arm Tests to verify if the calibration positions of each Buffer Arm are adjusted correctly per adjustment procedure, Section V.

Hub Sensor Test. The Hub Sensor Tests enable testing the operation of the Reel-In-Place Sensor and the File Protect Sensor. The digital display indicates the status of the tape reel (NOT IN = Not inserted; IN PLACE = Tape inserted). The WRITE ENBL light indicates the status of the Write Protect Sensor.

RL Servo (Reel Servo) — This test exercises the servo system. The RL Servo Test requires that a tape reel be inserted (not loaded) before beginning the test. The test executes a diagnostic load but does not perform a BOT search. If a reel of tape is not inserted at the start of this test, the readout displays LOADING, then, ABORTED. In the event that the reel had been loaded before the start of the test, the readout displays G = 1.XX. In either case, the test is not performed.

CAUTION

The RL Servo Test is also used in a critical adjustment procedure required if any component of the Reel Servo System is replaced. This procedure includes setting up parameters that govern operation of the Executive Program in the Calibration EEPROM. To prevent corrupting the **Executive Program**, make sure that the Calibration Jumper (ST3) on the Drive Electronics Board is in **NON-ENABLE Position** (Ref Figure 5-31).

Chart C. Drive Adjustment Tests

Step	DISPLAY	ACTION (Press:)	DISPLAY	ACTION (Press:)	DISPLAY	NOTE
0	DRV ADJ					*
1		ENTER	BUF ARMS	ENTER	RELAXING TAKE X.X SUPP X.X	**
2		SCAN	HUB SENS	ENTER	NOT IN IN PLACE	^
3		SCAN	RL SERVO	ENTER	LOADING	^ #

NOTE:

- * Press DIAG to exit from any Menu or Submenu.
- ** RELAXING displays as the Arm relaxes, then TAKE X displays. Pressing DIAG causes display to indicate: RETRACT, and the Arm retracts.
- ^ This display varies according to Loading status.
- # The final display indicates as follows:

G = 1.XX displays if test is satisfactory. XX represents Reel Servo Gain.
An Error Messages per Table 4-3 displays if test fails.

4.5.2.6 SET UP

In the Set Up Mode, the operator sets the basic operating parameters of the Drive. Except for UNIT NUM, DENS SEL, and DEFL DENS, the Calibration Jumper* (ST3) must be placed in ENABLE Position (EN) for the Set Up Procedures. Set Up can be done with or without tape loaded. The basic parameters displayed and set up in this Mode are:

- * In most procedures of Set Up Mode, and all of Calibration Mode, the Calibration Jumper must be installed in the ENABLE Position to store the selected parameters. If the jumper is not installed, and a store (LOAD) operation is attempted, the Readout displays, "JUMPER?" and the RWND/UNL LED flashes. Pressing RWND/UNL aborts the Set Up or Calibration attempt. (See Section V - Calibration and Set Up, Electronic - for Calibration Jumper installation.)

When Set Up or Calibration is complete, replace the Calibration Jumper to its original position. **CAUTION: DO NOT TURN POWER OFF UNTIL CALIBRATION JUMPER IS RETURNED TO ITS ORIGINAL POSITION.** To do so could destroy vital data in the Calibration EEPROM.

- a. **UNIT NUM:** Unit Number. The Drive Unit Number (Address). This can be set to any logical number from 0 thru 7. (Cal Jumper can be in either position.)
- b. **DENS SEL:** Density selection. When set to normal the drive will operate in local or remote density modes, depending on the REMOTE light on the front panel. When in REM ONLY, the drive will only allow selection of REMOTE mode.
- c. **DEFL DEN:** Default Density. The Density to which the Drive will default to on Power Up. Default Density can be set to 800 cpi, 1600 cpi, and 3200 cpi, and can be set for Local or Remote (Host) Control. (Cal Jumper can be in either position.)
- d. **SPEED:** The Speed to which the Drive will default to on Power Up. Speed can be set to 50 or 100 ips, Host Select; or Automatic Select wherein the Drive automatically selects the speed for optimum performance, based on the Host Re-Instruct Time. In Host Select, if the Host does not designate, the speed is 50 ips.
- e. **TIMEOUT:** 25-foot Timeout. The 25-foot Timeout Parameter, when set to ON, causes the Drive to stop tape motion and report a Hard Error if no data is detected within 25 feet of tape. This feature prevents tape from running off the reel at the end of tape.
- f. **SECURITY:** Security Erase. Security Erase, when enabled, allows the Drive to accept a Security Erase Command from the Host which will cause the Drive to erase tape from its present position to 3 feet past EOT.
- g. **PARITY:** For Hosts that provide Parity, the Drive can be set either to check or ignore parity of Write Data from the Host.
- h. **LONG GAP:** Interrecord Gap. To accommodate certain Host requirements, the Interrecord Gap that results from the Host generated LONG GAP Command can be set to any one of the values: 0.45, 0.6, 1.2, or 2.5 inches. Regardless of its setting, however, Gap Length terminates if a Write Command is received before its set time.
- i. **NRZI CCG:** NRZI Check Character Gate. When enabled, this option causes the Drive to send the CRC and LRC Characters to the Host following each data block.
- j. **CLR FBSY:** Clear Formatter Busy. Enabling this option, allows the Data Busy Signal (DBY) to clear the Formatter Busy Signal (FBSY). For Hosts that reinstruct after each FBSY, set this option to "WITH DBY" to facilitate streaming. To clear FBSY after repositioning, following a 100 ips Command, set to "POSTREPO" .

- k. **IFEN:** Interface Enable Polarity. Setting this option to **INVERT**, inverts the FEN Signal from the Host. Setting this option to **NORMAL**, leaves the Signal uninverted. For Hosts that use FEN as a pulse to enable the Formatter, set IFEN to **INVERT**. For Hosts that support FEN, set IFEN to **NORMAL**.
- l. **DENS OUT:** Density coding method used on the Host interface. Choose either coded for reporting of all 4 densities of **NRZ ONLY** or only report **NRZI**.

As required, install the Calibration Jumper in **ENABLE** Position; and set up the Drive by accessing the Set Up Mode as illustrated in Chart D. With the Readout displaying **SET UP**, press **ENTER**. Repeatedly press **SCAN** to access the desired Feature; then press **ENTER** to display the first of the available parameters. Repeatedly, as necessary, press **SCAN** to display and select the desired parameter. Now Press **ENTER** once more. The Readout displays **LOAD?**. Press **LOAD** to enter and save the parameter.

Chart D. Set Up

Step	DISPLAY	ACTION (Press:)	DISPLAY	ACTION (Press:)	DISPLAY *
0	SET UP	***		*** ^	
1		ENTER	UNIT NUM	ENTER SCAN	UNIT X **
2		SCAN	DENS SEL	ENTER SCAN	NORMAL REM ONLY
3		SCAN	DEFL DEN	ENTER SCAN SCAN SCAN SCAN SCAN	800 800 REM 1600 1600 REM 3200 3200 REM
4		SCAN	SPEED	ENTER SCAN SCAN SCAN	HOST SEL AUTO 50 IPS 100 IPS
5		SCAN	TIME OUT	ENTER SCAN	25FT ON 25FT OFF
6		SCAN	SECURITY	ENTER SCAN	ENABLED DISABLED
7		SCAN	PARITY	ENTER SCAN	CHECK IGNORE
8		SCAN	LONG GAP	ENTER SCAN SCAN SCAN	0.45 INCH 0.6 INCH 1.2 INCH 2.5 INCH

Chart D. Set Up (Continued)

Step	DISPLAY	ACTION (Press:)	DISPLAY	ACTION (Press:)	DISPLAY *
9		SCAN	NRZI CCG	ENTER SCAN	ENABLED DISABLED
10		SCAN	CLR FBSY	ENTER SCAN	WITH DBY POSTREPO
11		SCAN	IFEN	ENTER SCAN	NORMAL INVERT
12		SCAN	DENS OUT	ENTER SCAN	CODED NRZ ONLY
<p>NOTE: * The last parameter selected (in a previous Set Up) displays when ENTER is pressed. Repeatedly press SCAN to select a new parameter. Then press LOAD to store the new parameter.</p> <p>** X = Unit Number 0 thru 7.</p> <p>*** Press DIAG to exit from any Menu or Submenu.</p> <p>^ Press ONLINE to display Firmware Revision Level.</p>					

4.5.2.7 CALIBRATION

NOTE 1: See NOTE under par. 4.5.2.5.

NOTE 2: A reel of tape must be loaded to accommodate the Calibration Tests.

NOTE 3: After completing the Calibration sequence and, with Drive AC still ON, replace the Calibration Jumper to NON-ENABLE Position.

Using this menu, the operator can manually or automatically calibrate Read Analog Amplifiers for all the densities. Similarly, the Write Current can be calibrated automatically. Chart E illustrates the operating procedure using the ENTER-SCAN sequence. Confirming the selection is done by pressing ONLINE in response to the Readout, CONFIRM?. Press DIAG to exit from any Menu.

Chart E. Calibration

Step	DISPLAY	ACTION (Press:)	DISPLAY	ACTION (Press:)	DISPLAY *
0	CAL	***		***	
1		ENTER	AUTO	ENTER SCAN SCAN SCAN	ALL 800 1600 3200
2		ENTER	MANUAL	ENTER SCAN SCAN	800 1600 3200

Chart E. Calibration (Continued)

Step		A		B		C
Step (Press)	DISPLAY	ACTION (Press)	DISPLAY	ACTION (Press)	DISPLAY	ACTION
CALIBRATE AUTO:						
1.	SCAN	ALL 800	ENTER ENTER 50 IPS	ENTER ENTER 100 IPS	CONFIRM? CONFIRM? CONFIRM?	Press ONLINE to confirm.
2.	SCAN	1600	ENTER SCAN 50 IPS	ENTER ENTER 100 IPS	CONFIRM? CONFIRM? CONFIRM?	
3.	SCAN	3200	ENTER SCAN 50 IPS	ENTER ENTER 100 IPS	CONFIRM? CONFIRM? CONFIRM?	
CALIBRATE MANUAL:						
1.	SCAN	800 1600	ENTER SCAN 50 IPS	ENTER ENTER 100 IPS	CONFIRM? CONFIRM? CONFIRM?	(See NOTE) Press ONLINE to confirm.
2.	SCAN	3200	ENTER SCAN 50 IPS	ENTER ENTER 100 IPS	CONFIRM? CONFIRM? CONFIRM?	Press DIAG to abort.
<p>NOTE: Pressing ONLINE displays: RANGE X (Calibration Range) Then pressing SCAN displays: AMP N X (Read Amp Channel N Gain) (See Section 5.4.2.9 for Calibration Procedure.)</p>						

4.5.2.8 DATA DIAGNOSTICS

Data Diagnostics allows offline testing of the data path one module at a time. In this mode, to prevent the possibility of disturbing the calibration settings, the Calibration Jumper must be installed in Operate Position. There are three Submenus in Data Diagnostics:

- a. MODE Functions set up Drive Parameters for testing.
- b. COMMANDS select and initiate the test to be run
- c. ERRORS display accumulated errors of various types in the error log.

Chart F illustrates entering Data Diagnostics. The following subparagraphs describe the three major categories of Diagnostics Tests. Load a reel of tape before starting Data Diagnostics Tests.

Chart F. Entering Data Diagnostics

Step	DISPLAY	ACTION (Press:)	DISPLAY	ACTION
1	DATADIAG	ENTER	MODE	Press ENTER to access selected Submenu
2		SCAN	COMMANDS	
3		SCAN	ERRORS	

MODE (Test Options). In this category, the Operator sets up the Drive to operate with specific parameters. He repeatedly presses SCAN to display the desired categories (listed above); then uses the ENTER-SCAN sequence to select the various Submenu Parameters. Submenu Parameters are defined as follows: NOTE: The first parameter listed for each Option is the default parameter. Chart G illustrates operating the Modes Menu.

<u>Option</u>	<u>Parameters</u>	<u>Description</u>
ON ERROR	CONTINUE STOP	Drive continues motion on detecting error. Drive stops on error.
AT EOT	REWIND STOP	Drive rewinds when detecting EOT. Drive stops at EOT.
BLK SIZE	4, 256, 513, or 1024	Drive generates selected-size data blocks.
DATA	ALL ONES, ALL ZERO, INCREMENT, RANDOM, ALT (00-FF), USER	Drive generates data pattern selected. See NOTE.
SPEED	50 IPS, 100 IPS	Drive operates at speed selected.
RE-INST	STREAM STRT/STP SINGLE	Drive operates in streaming Mode. Drive operates in Start/Stop Mode. Drive reads or writes one block.

NOTE: The USER Display indicates that the last 1024 data bytes that accompanied the last Write Command to the Drive is presently available as test data. USER test data is destroyed and the USER Display cannot be accessed once any other data pattern has been entered.

Chart G. Accessing the Modes Submenu

Step	DISPLAY	ACTION (Press:)	DISPLAY	ACTION (Press:)	DISPLAY *
1	MODE	ENTER	ON ERROR	ENTER SCAN	STOP CONTINUE
2		SCAN	AT EOT	ENTER SCAN	REWIND STOP
3		SCAN	BLK SIZE	ENTER SCAN SCAN SCAN	4 256 513 1024
4		SCAN	DATA	ENTER SCAN SCAN SCAN SCAN SCAN	ALL ONES ALL ZEROS INCREMENT RANDOM ALT (00-FF) USER

Chart G. Accessing the Modes Submenu (Continued)

Step	DISPLAY	ACTION (Press:)	DISPLAY	ACTION (Press:)	DISPLAY *
5		SCAN	SPEED	ENTER SCAN	50 IPS 100 IPS
6		SCAN	RE-INST	ENTER SCAN SCAN	STREAM STRT/STP SINGLE
<p>NOTE: * When ENTER is pressed, the option displayed is the last one selected (during a previous diagnostics session).</p>					

COMMANDS: Under the Commands Category, ENTER accesses the Submenu, and SCAN selects the test to be run, and START/STOP starts and ends the test. If a runaway occurs, due to module failure, pressing DIAG will force a hard stop but lose tape position. Commands are defined as follows: **NOTE:** START/STOP executes the Commands using parameters set in the Mode Menu.

- LOOP DIG** Data loops from the Write Digital to the Read Digital Sections without going through the Read Analog Section or the Head. Tape not required.
- LOOP ALG** Data loops from the Write Section to the Read Digital Section through the Read Analog Module without going through the Head or the Pre-Amp. Tape not required. Command executes in all densities except NRZI.
- WRITE** Drive writes Data to tape per selected Mode Parameters (listed above). No retry on error. If tape is write protected, display is: "CAN'T WRITE".
- WRT W/RE** Drive writes Data to tape using Retry Sequence for Blocks In Error. Retry consists of: Backspace, Erase, Write.
- READ** Drive reads Data from tape in forward direction, comparing it to pattern selected in Mode Menu.
- READ REV** Drive Reads Data from tape in the reverse direction. No compare made.
- READ/RR** If last command caused a forward motion, the Drive alternately and repeatedly reads reverse and forward over the **previous** data block. If the last command caused a reverse motion, the Drive alternately and repeatedly reads forward and reverse over the **next** data block. To stop this test, press START/STOP. **NOTE:** Compare is made only in Read Forward Operations.
- FMK TEST** Drive continually writes File marks and confirms File mark Status.
- WRT/WFMK** Drive continually and alternately writes a Data Block and a File mark.
- WR/RR/RD** Drive writes a block, reads it in reverse, then reads it forward.

NOTE: These tests can be stopped by Pressing START/STOP; but, If in MODE Category, ON ERROR, STOP was selected, the Drive will stop whenever an error is detected.

Chart H. Accessing the Commands Submenu

Step	DISPLAY	ACTION (Press:)	DISPLAY	ACTION
1	COMMANDS	ENTER	LOOP DIG	Press ENTER to enable the parameter, and Press START/STOP to execute Command; or Press SCAN to advance to the next parameter.
2		SCAN	LOOP ALG	
3		SCAN	WRITE	
4		SCAN	WRT W/RE	
5		SCAN	READ	
6		SCAN	READ REV	
7		SCAN	READ/RR	
8		SCAN	FMK TEST	
9		SCAN	WRT/WFMK	
10		SCAN	WR/RR/RD	
NOTE: Commands execute using the parameters set up in Modes Menu.				

ERRORS Display. The Errors Function displays selectable types of errors. Repeatedly pressing SCAN in turn causes each type of error to be **displayed**. Pressing ENTER **resets** the currently displayed error reading and scans to the next display. Errors are defined as follows: Chart H illustrates using the Errors Submenu

- EIC(0-7,P) Error in Channel 0 thru 7 and P. Accumulation of Hard Errors and Corrected Errors.
- WPAR Write Parity Errors. Hard Errors flagged because of a detected Parity Error of the Write Data Bus from the Host.
- CMP Compare Errors. Data returned by Read Section does not match Data sent to the Write Section during a Write Command; or Data read does not match the pattern selected on Diagnostic Read Command.
- HER Hard Error (Non-Recoverable) flagged by the Read Section. See Section I for detailed description of Hard Errors.
- STE Single Track Error. Any Corrected Error in PE or DDPE.
- FMK File mark Error. File mark Status Report was not returned following a Write File mark Command.

NOTE: Each Error display is followed by a number (xxx) or "OVR". This represents the number of errors detected (xxx) or a Counter Overflow (OVR = over 255).

Chart I. Accessing the Errors Submenu

Step	DISPLAY	ACTION (Press:)	DISPLAY	ACTION
1	ERRORS	ENTER	EIC (0-7,P) XXX	Press ENTER to clear the error count and advance to the next parameter. Press SCAN to advance to the next parameter without clearing error count.
2		SCAN	WPAR XXX	
3		SCAN	CMP XXX	
4		SCAN	HER XXX	
5		SCAN	STE XXX	
6		SCAN	FMK XXX	

SECTION V
MAINTENANCE INSTRUCTIONS

SECTION V MAINTENANCE

5.0 GENERAL

Procedures described herein are limited to Preventive and Corrective Maintenance that can be accomplished in the field, and includes adjustment and replacement of PCBAs and other major components of the Drive. PCBAs are not considered field repairable and, if found defective, should be returned to the manufacturer for repair.

5.1 PREVENTIVE MAINTENANCE

To ensure continued trouble-free operation, complete the following preventive maintenance tasks regularly as recommended.

5.1.1 DAILY INSPECTION

All components in the tape path must be kept scrupulously clean. Daily, or after four hours of tape motion, inspect Deck Assembly, Read/Write/Erase Head, Rollers, and Sensors, for cleanliness. Look for dirt and oxide accumulation. Clean as required.

5.1.2 CLEANING

CAUTION

Using **non-recommended** cleaning fluids can damage components of the Tape Drive. Using excessive amounts of the recommended cleaning fluid can damage the Tape Drive by penetrating roller bearings, idler rollers, tape guides, capstan, or drive motor, and destroying lubrication.

5.1.2.1 TAPE REELS

Before installing any tape reel onto the Supply Hub, it is recommended that the inner surface of the Tape Reel Hub be cleaned with a lint free cloth dampened with clean water to remove any dirt, grease or other contamination.

5.1.2.2 ERASE/WRITE/READ HEAD CLEANING

Remove accumulation of oxide and/or dirt from the Erase/Write/Read Head surface (Fig. 5-1) using a clean lint-free cloth or cotton swab dampened with 1.1.1 trichloroethane or isopropyl alcohol (See **CAUTION** above). Wipe the Head with firm but gentle vertical strokes.

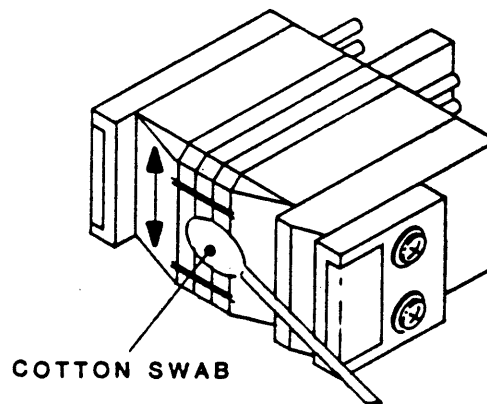

Figure 5-1. Erase/Write/Read Head Cleaning

5.1.2.3 TAPE PATH CLEANING

Miscellany (Figure 5-2)

Clean tape guides, rollers (except Capstan Roller), and the sapphire tape cleaners with a cotton swab dampened with isopropyl alcohol or 1.1.1 trichloroethane. Clean the Capstan rubber Roller with a cotton swab dampened with water or, if excessively dirty, dampened with mild soapy water. Dry thoroughly with a clean lint-free cloth.

Reel Locking Fingers (Figure 5-19)

With no tape reel on the Supply Hub, press the Manual Reel Locking Lever (See Section VI, Figure 6-1) while manually turning the Reel Hub clockwise until the Reel Locking Fingers extend fully outward. Then clean the Rubber Pads on the Fingers with a clean cotton swab or cloth dampened with water or if excessively dirty, with mild soapy water.

After cleaning the Rubber Pads, again press the Manual Reel Locking Lever and manually turn the Reel Hub counterclockwise until the Fingers retract to original position.

5.1.3 ROUTINE ADJUSTMENTS

There are no routine adjustments necessary to the Tape Drive. **DO NOT** make any adjustments except for corrective maintenance.

5.1.4 LUBRICATION

The Tape Drive uses only sealed, life-time lubricated bearings. No lubrication is required. **CAUTION: Do not lubricate.**

5.1.5 HEAD WEAR

The Kennedy Co. ceramic-coated Head normally lasts the lifetime of the Drive. However, the Head should be replaced after 5000 hours of tape motion.

5.2 CORRECTIVE MAINTENANCE

Corrective Maintenance consists of tests and diagnostics for isolating malfunctions to a field-replaceable component. Field replaceable components are itemized in the Recommended Spare Parts List (Section VI, Table 6-1).

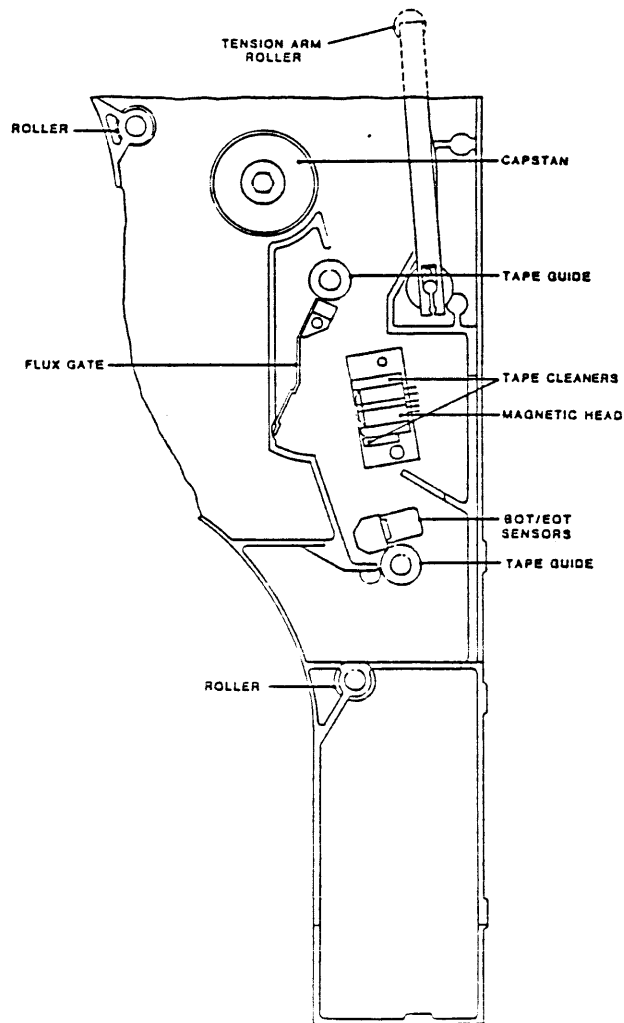

Figure 5-2. Tape Path Cleaning

5.2.1 TOOLS AND TEST EQUIPMENT REQUIRED (Table 5-1)

Table 5-1. Tools and Test Equipment Required

ITEM	DESCRIPTION	ITEM	DESCRIPTION
Box Wrenches	Common	Spring Scale	Common
Capstan Puller	P/N 54-00100-001	Tape Guide Align Tool	P/N 54-00103-001
Cleaner Fluid	1.1.1 Trichloroethane or Isopropyl Alcohol	Torque Tool	Common
Cloth or Q-Tip	Lint Free	Tracking Tape	P/N 13-00106-001
Gauge	Feeler	Collet Setting Tool	P/N 54-00173-001
Hex Wrenches	3/32, 1/8, 5/32, 3/16	Take-up Arm Zero Pos Tool (S/C)	P/N 99-00633-002*
Multimeter	Digital	Take-up Arm Relax.Pos Tool (S/C)	P/N 99-00633-001*
Oscilloscope	Dual Trace	Take-up Arm TLIM Pos Tool (S/C)	P/N 99-00629-001*
Pliers	Long-nose	Sup. Arm Zero Pos Tool (S/C)	P/N 99-00631-002*
Pliers	C-Clip Retainer Removal	Sup. Arm Relaxed Pos Tool S/C)	P/N 99-00631-001*
Screwdriver	Spade Tip	Sup. Arm SLIM Pos Tool (S/C)	P/N 99-00619-001*
Screwdriver	Stubby, No. 1 Phillips	Take-up Arm Zero Pos Tool (D/C)	P/N 99-00634-001**
Screwdrivers (2)	Phillips, No. 1 and 2	Take-up Arm TLIM Pos Tool (D/C)	P/N 99-00635-001**
Skew Tape	P/N 54-00036-001	Sup. Arm Zero Pos Tool (D/C)	P/N 99-00632-001**
Spring Hook	Common	Sup. Arm TLIM Pos Tool (D/C)	P/N 99-00630-001**
			*Included in Tool Kit P/N 54-00172-001
			**Included in Tool Kit P/N 54-00174-001

S/C = Sand Cast Deck D/C = Die Cast Deck

5.2.2 ACCESSING THE DRIVE

A. Operating the Rack Mount Slides:

1. Operate the Release Lever located just inside the Front Tape Access Door (Figure 6-1), and (for rack-mounted units) pull the Drive outward on its Slides, or (for Table top units) pull the Cabinet backward off the Drive.
2. To access the top of the Drive, turn the two Locks Screws, located on the top Cover, 1/4 turn ccw, and lift the Cover to full open position. Push the Dust Cover Support Bar into Lock Position (See Figure 2-2).

B. Access the Drive below the Deck Assembly as follows:

1. Close and lock the Dust Cover.
2. Remove two upper Lock Bolts on the sides of the Drive (See Figure 2-7A).
3. Lift the Deck Assembly and latch the Support Bar to hold the Deck Assembly in Maintenance Position (See Figure 2-7A).

C. Restore the Deck Assembly to Operate Position as follow:

1. Lift the Deck Assembly slightly, and unlatch the Support Bar.
2. Replace the Support Bar in its original position, and lower the Deck Assembly to its original position.
3. Replace and tighten the two Lock Bolts.

5.2.3 TROUBLESHOOTING

Troubleshooting the Tape Drive consists of using diagnostics, and self-tests to diagnose mechanical, electromechanical and electronic malfunctions.

Diagnostics include firmware-controlled tests and exercises that can be initiated by the Operator from the Drive Front Panel. The Digital Display on the Front Panel provides diagnostic readouts. Section IV describes how to operate Diagnostics.

Self-Tests occur with each Power Up, or can be manually initiated using the Diagnostics Menu. Self-Tests include failure codes and diagnostic readouts on the Front Panel Digital Display. Section IV describes the Self-Tests.

5.2.3.1 ACCESSING THE DRIVE FOR TROUBLESHOOTING

CAUTION: A solidly grounded ESD Wrist Strap should be worn whenever touching or handling any Circuit Board or other electronic assembly in the Drive.

WARNING: Dangerous AC voltage exist in and about the Voltage Selector, the EMI Filter, the Power Transformer, Fan, and the Power Switch on the Front Panel. ALWAYS UNPLUG THE AC LINE CORD BEFORE WORKING IN THESE AREAS. (See Schematic Diagram 7109 (sheet 2) for illustration of ac voltage distribution.

5.2.3.2 SAFETY INTERLOCKS

The Drive includes personnel safety interlocks that operate when the Tape Access Door or Top Dust Cover is opened. To operate the Drive for troubleshooting, the technician must defeat the Interlocks as follows:

- A. With ac power ON, unload tape (as applicable).
- B. Raise the Deck assembly to Maintenance Position per 5.2.2.
- C. On the Drive Electronics Board, move the Diagnostics Jumper (ST4 - See Figure 5-31) from its present position as follows:
 1. If original position is EN: press and hold ENTER, and move from EN to DIS.
 - If original position is DIS: press and hold ENTER, and move from DIS to EN to DIS.
 2. If you intend to test, calibrate, or operate the Drive via Diagnostics Pushbuttons, move the Jumper from DIS to EN (Do not press ENTER).
 3. From Step 1 you have one minute to lower the Deck Assembly and load tape. If tape has not been loaded within one minute, repeat Step C.
- D. Display flashes "NO INTLTK". Press DIAG to start Diagnostics.
- E. To reactivate the Interlock, unload tape.

5.3 PARTS REPLACEMENT

Components and Major Assemblies of the Drive are not considered to be field repairable. If found defective, replace the Component or Assembly with an appropriate spare part. The following subparagraphs describe replacement procedures for these Components and Assemblies. For these procedures, unless otherwise directed, place the Drive on a table top right side up, and raise the Deck to Maintenance Position per par. 5.2.2.

Torque Requirements: Torque screws to the following standards (inch pounds): #4-40: 4 to 6; #6-32: 7 to 9; #8-32: 8 to 10; #10-32: 18 to 20.

5.3.1 PRINTED CIRCUIT BOARDS IN CARD CAGE (Fig. 5-3)

- A. Loosen two Cover Screws near ends of the Card Cage Cover, and remove Cover.
- B. As applicable, disconnect cables from PCB to be removed.
- C. Grasp PCB Ejectors firmly, and pull ejectors towards the side of the unit. Board should pop partly out of the slot.
- D. Grasp the PCB Ejectors and slide the Board out of the slot.

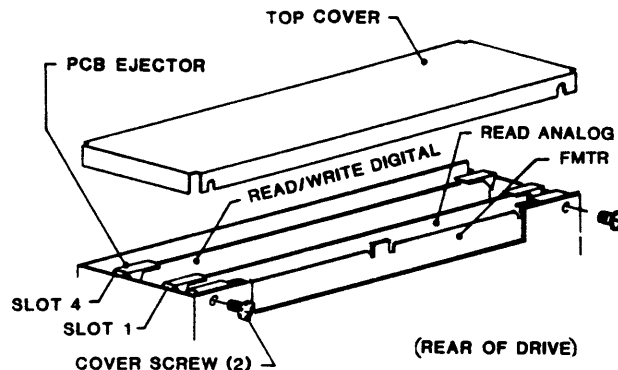

Figure 5-3.
Card Cage

To replace: Insert PCB in Card Cage and press firmly downward until PCB is fully seated in Mother Board.

Replace Card Cage Cover.

5.3.2 DRIVE ELECTRONICS BOARD

Refer to Section VI, Figure 6-4 for illustration of the Drive Electronics Board.

- A. Remove four nuts that hold the Power Supply Bracket to the Chassis, and slide the Power Supply with Bracket to the left.
- B. Disconnect cables from the Drive Electronics Board.
- C. Remove six Mounting Screws that hold the Drive Electronics Board to the Chassis.
- D. Unplug the Drive Electronics Board from the Mother Board, and lift it from Drive.

To replace: Reverse removal procedure*.

***Note:** Following Drive Electronics Board replacement, all electronic Set Ups and Calibration must be performed. See Sections 5.4.2.9 and 5.5.3.

5.3.3 INTERCONNECT PCBA

Refer to Section 6, Figure 6-3 for illustration of the Interconnect Board.

- A. Noting the location of each connector, disconnect all connectors from Interconnect Board, tagging each connector for identification and location.
- B. Remove four Board Mounting Screws.
- C. Lift the Interconnect Board out of the Drive.

To replace: Reverse removal procedure.

5.3.4 HUB LOCK SOLENOID (Fig. 5-4)

- A. Disconnect two wires from the Solenoid.
- B. Remove 2 screws holding Solenoid Mounting Bracket to Deck.
- C. Lift Bracket/Solenoid Assembly and detach it from Lock Actuator.
- D. Remove the Solenoid (2 screws) from the Bracket.

To replace: Reverse removal procedure. Adjust per paragraph 5.4.2.8. Torque screws to 13 +/-1 inch-pounds.

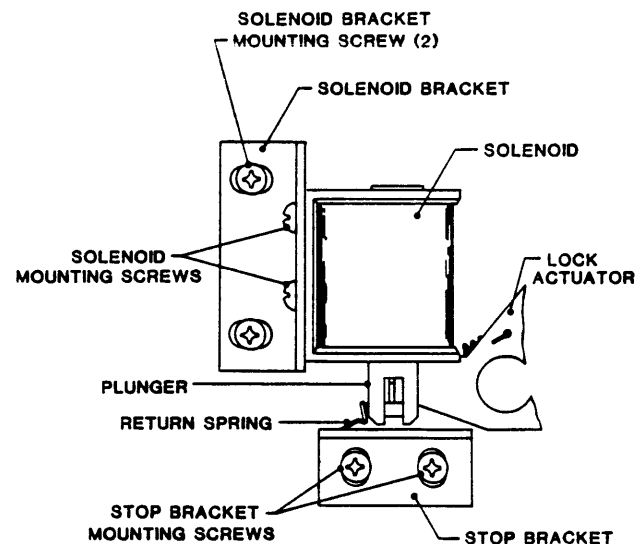

Figure 5-4.
Hub Lock Solenoid

5.3.5 READ PREAMPLIFIER

Refer to Figure 5-27, and Section VI, Figure 6-3 for illustration of the Read Preamp Board.

- A. Remove Clamp Plate (below Deck) that clamps cables and the Read Preamp Board.
- B. Unplug the Read Preamp Board from the Magnetic Head (top of Deck).
- C. Cut tie wraps that secure Read Preamp Cable, and unplug Cable Connector from Read Analog Board 9017.
- D. Remove the Read Preamplifier Board from the Drive.

5.3.6 FAN (Fig. 5-5)

- A. Remove all PCBs from Card Cage (paragraph 5.3.1).
- B. Unplug connector at Fan Body.
- C. Using stubby Phillips screwdriver, remove 4 screws holding Fan to sheetmetal support.
- D. Remove Finger Guard from Fan, and install it on new Fan, using original hardware.

To replace: Reverse removal procedure. Note direction of air flow.

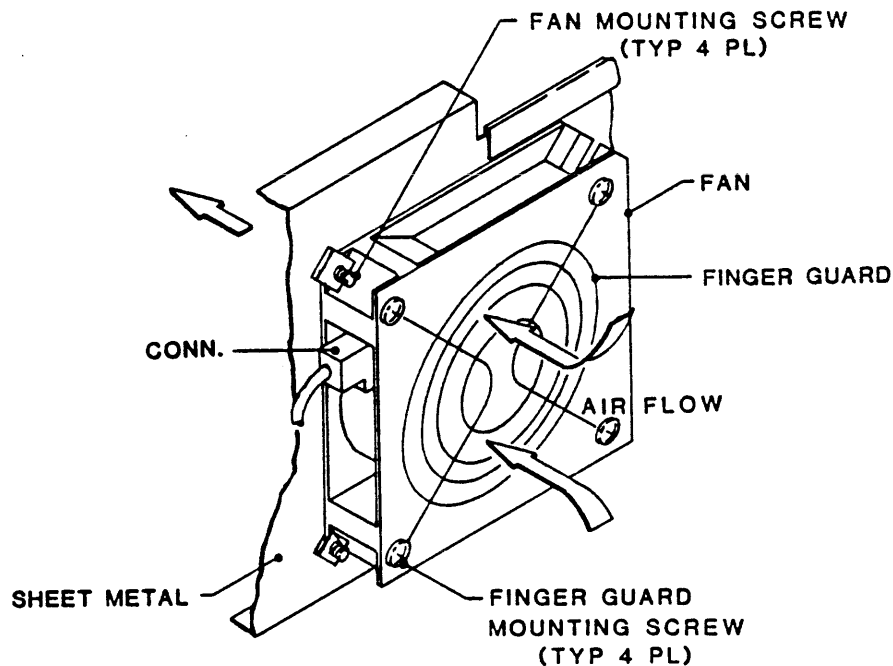
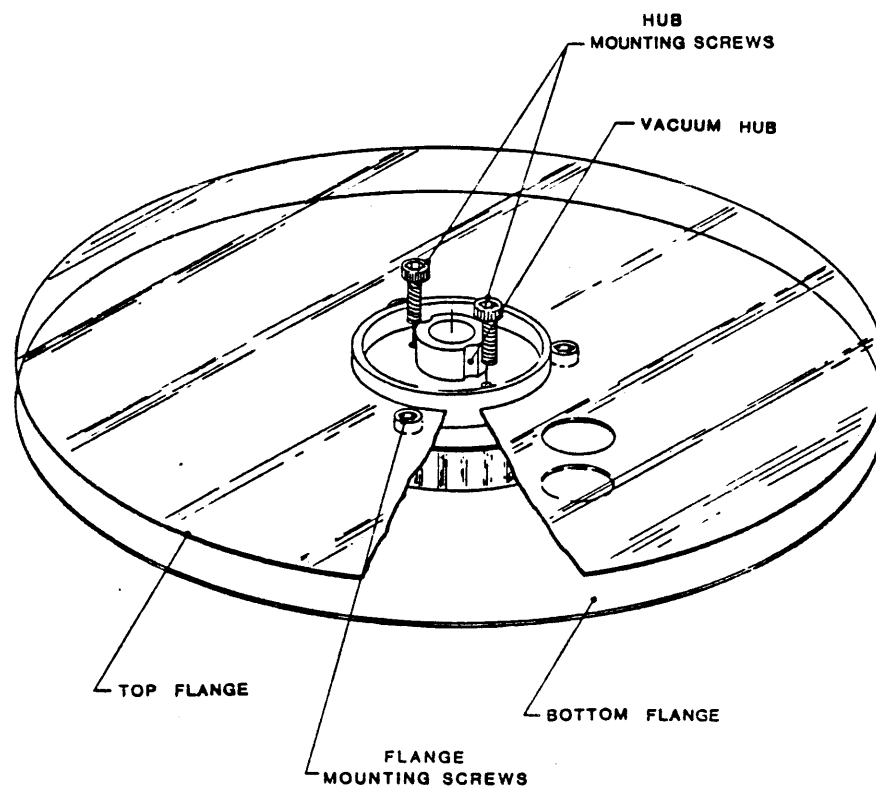

Figure 5-5. Fan

5.3.7 TAKE-UP REEL ASSEMBLY (Fig. 5-6)**Tools Required:** 9/64th-inch Hex Wrench

- A. Lift open Top Cover of the Drive per 5.2.2.
- B. Remove three Socket-Head Cap Screws from Top Flange, and remove Top Flange.
- C. Remove two Socket-Head Cap Screws from the Vacuum Hub.
- D. Grasp the Vacuum Hub firmly with both hands and remove by pulling upwards.

To replace: Reverse removal procedure.**Figure 5-6. Take-up Reel Assembly**

5.3.8 TAKE-UP ARM ASSEMBLY (Fig. 5-7)

- A. To ensure that the new Arm will be installed in approximately the same angular position on the Shaft as the original Arm, and the zero point will not be altered, mark the orientation of the original Arm on the Shaft. A small dot on the shaft in line with the Arm (as illustrated) will suffice.
- B. Remove the Take-up Arm Retraction Spring as follows:
1. Turn AC power on. Do not turn AC power off during this procedure.
 2. Press DIAG, then ENTER, and scan to DRV ADJ. Mode.
 3. Again press ENTER. The Readout should display BUFF ARMS.
 4. Press ENTER again. The Readout should display RELAXING, and the Take-up Arm should unlock from its original position and move to the "relaxed" position.
 5. Remove the Retraction Spring from the Swivel with a Spring Hook or similar tool.
- C. Using a 1/4-inch box wrench, loosen the Clamp Bolt that secures the Arm to the Shaft, and lift the Arm Assembly off the Shaft being careful not to remove shims from under the Arm.

To replace: Reverse removal procedure:

- a. Snug the Clamp Bolt to prevent the Arm from turning on the Shaft.
- b. Check and as necessary adjust Buffer Arm Roller Height per paragraph 5.4.2.1.
- c. Check and as necessary adjust Spring Tension per paragraph 5.4.2.4.
- d. Torque Clamp Bolt to 20 inch-pounds.

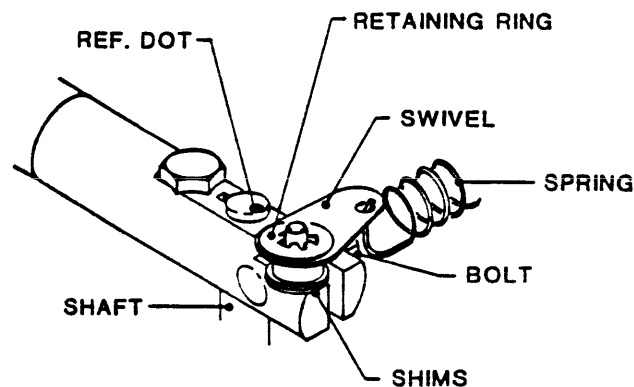

Figure 5-7. Take-up Arm and Supply Arm Assemblies

5.3.9 SUPPLY ARM ASSEMBLY (Fig. 5-7)

- A. Remove three Phillips screws and remove Supply Arm Cover Plate from the top of the Deck.
- B. Do procedure in paragraph 5.3.8.

5.3.10 RETRACT AND PIVOT SENSOR ASSEMBLIES, TAKE-UP ARM AND SUPPLY ARM (Fig. 5-8)

From above Deck:

- A. Remove the Take-up Arm or Supply Arm Assembly per paragraph 5.3.8 or 5.3.9.
- B. Remove Hinge Bracket that holds the Tape Path Cover and remove the Tape Path Cover.
- C. **For Take-up Arm only**, remove screws that hold the Take-up Arm Stop (Sand Cast only) and the Fixed Cover Plate and remove the Take-up Arm Stop and Fixed Cover Plate.
- D. **For Supply Arm only**, remove Supply Arm Cover Plate, and then with a Phillips Screwdriver, remove the Supply Arm Stop (Sand Cast only).

From below Deck:

- E. **On Take-up Arm Assembly only**, loosen the Lock Screw that attaches the Linkage to the Post, and remove the Linkage. Retain Linkage for later reinstallation.
- F. Cut tie-wraps and unplug connector P4 (for Take-up Assy) or P3 (for Supply Assy) from Interconnect Board 7228.
- G. Unplug P1 from Position Sensor PCBA 9069.

From above Deck:

H. (In this step, support and lower the Retract and Pivot Sensor Assy. as the last Mounting Screw is unscrewed.) Using a Hex Wrench, completely unscrew, but do not remove, two Socket-Head Mounting Screws that attach the Retract and Pivot Sensor Assembly to the Deck. Note position of shim and retain for use when reinstalling retract assembly.

To replace:

Reverse removal procedure. Check and adjust Buffer Arm per par. 5.4.2.

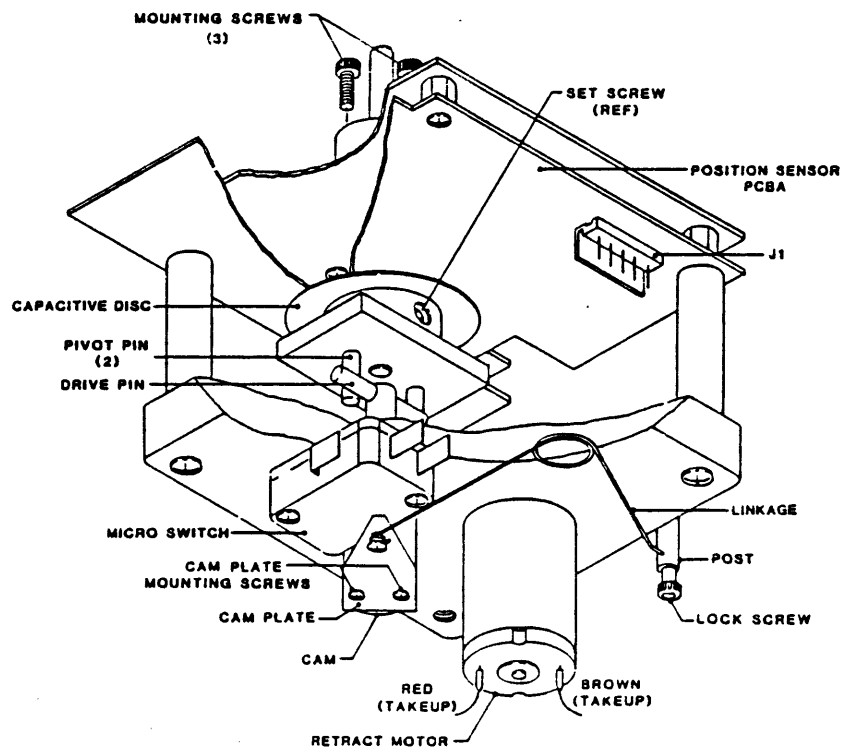

Figure 5-8. Take-up Arm Retract & Pivot Sensor Assembly

5.3.11 MOTHER BOARD PCBA (Fig. 5-9)

- A. Remove Card Cage Cover (paragraph 5.3.1).
- B. Remove all PCBAs from Card Cage.
- C. Unplug power connector J13 from Mother Board.
- D. Using Stubby or Offset Phillips Screwdriver, Remove six Mounting Screws and move Center Bulkhead out of way.
- E. Remove seven Phillips Head Screws that secure the Mother Board to the Chassis.
- F. Unplug Mother Board from Drive Electronics Board and, being careful not to damage the Connectors on the Mother Board, slide the Mother Board back and rotate it upward and out.

To replace: Reverse removal procedure.

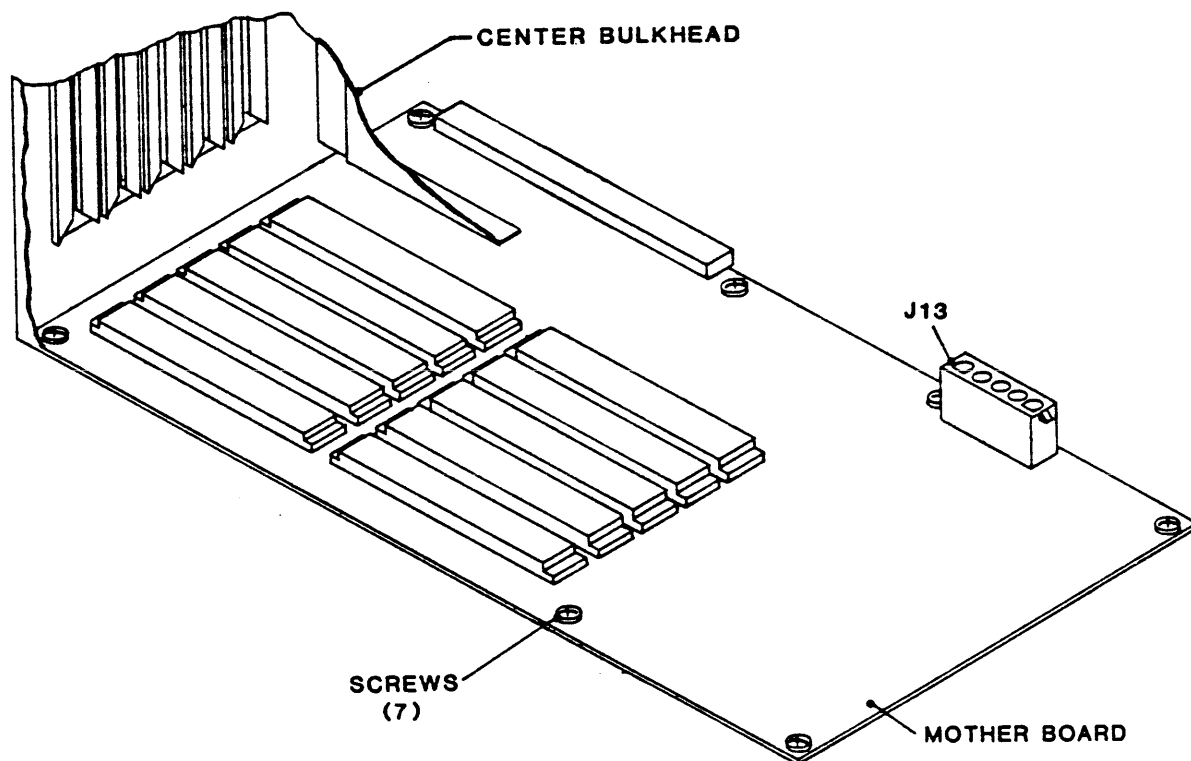

Figure 5-9. Mother Board

5.3.12 OPERATOR CONTROL PANEL PCBA (Fig. 5-10)

- A. Remove Panel Assembly from Deck per paragraph 5.3.22.
- B. Cut the Tie Wraps that attach the Switch and Solenoid Cable to the PCBA.
- B. Using A Nutdriver, remove six Mounting Nuts, and remove the Operator Control Panel PCBA.

To replace: Reverse removal procedure. Align the PCBA so that switch actuators can be moved freely in the openings in the Front Panel.

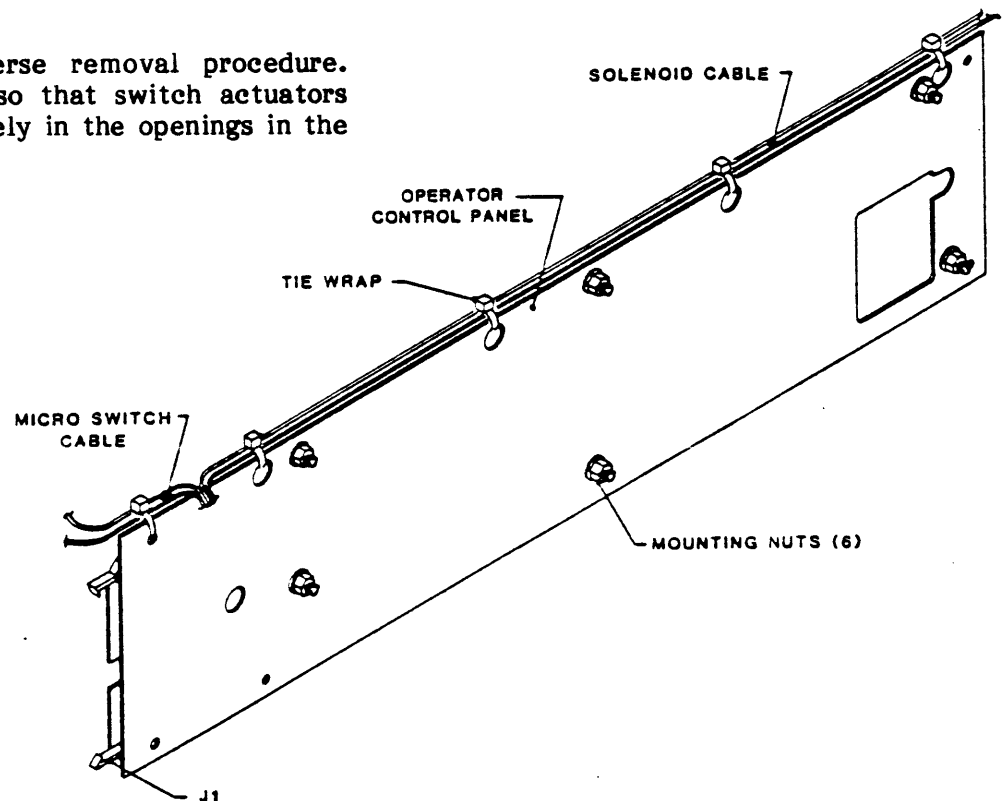

Figure 5-10. Operator Control Panel PCBA

5.3.13 EMI FILTER

Refer to Section VI, Figure 6-4 for illustration of EMI Filter.

- A. Turn off AC power and disconnect Line Cord from the AC power source.
- B. Lift Deck Assembly into Maintenance Position per 5.2.2.
- C. Disconnect input and output wires from EMI Filter.
- D. Remove two screws and remove EMI Filter.

To replace: Reverse removal procedure.

5.3.14 REEL-IN-PLACE SENSOR ASSEMBLY (Fig. 5-11)

Refer to Figure 6-2 for top view location of Sensor Assemblies.

- A. Remove two Phillips screws and two Spacers (no spacers on Die Cast Deck).
- B. Cut away Tie Wraps, and unplug the Cable from J13 on the interconnect PCBA.
- C. Remove the Reel-In-Place Sensor Assembly.

To replace: Reverse removal procedure. Align the Reel In Place Sensor Assembly centered within the chassis flanges and parallel with the Flange Surfaces, and with the specified space between the Sensor Assembly and the Sensor Tab. Torque Mounting Screws to 7 +/-1 inch-pounds.

Enter DIAG and SCAN to DRV ADJ, push enter. Push SCAN until HUB SENSE, push enter. The Hub Lock Solenoid will engage.

Place a write enabled tape on the Supply Hub and rotate hub clockwise until fingers engage and Hub hits Stop. Display should change from NOT IN to IN PLACE.

If indication is not as described, adjust the position of the sensor assembly until the proper display is achieved.

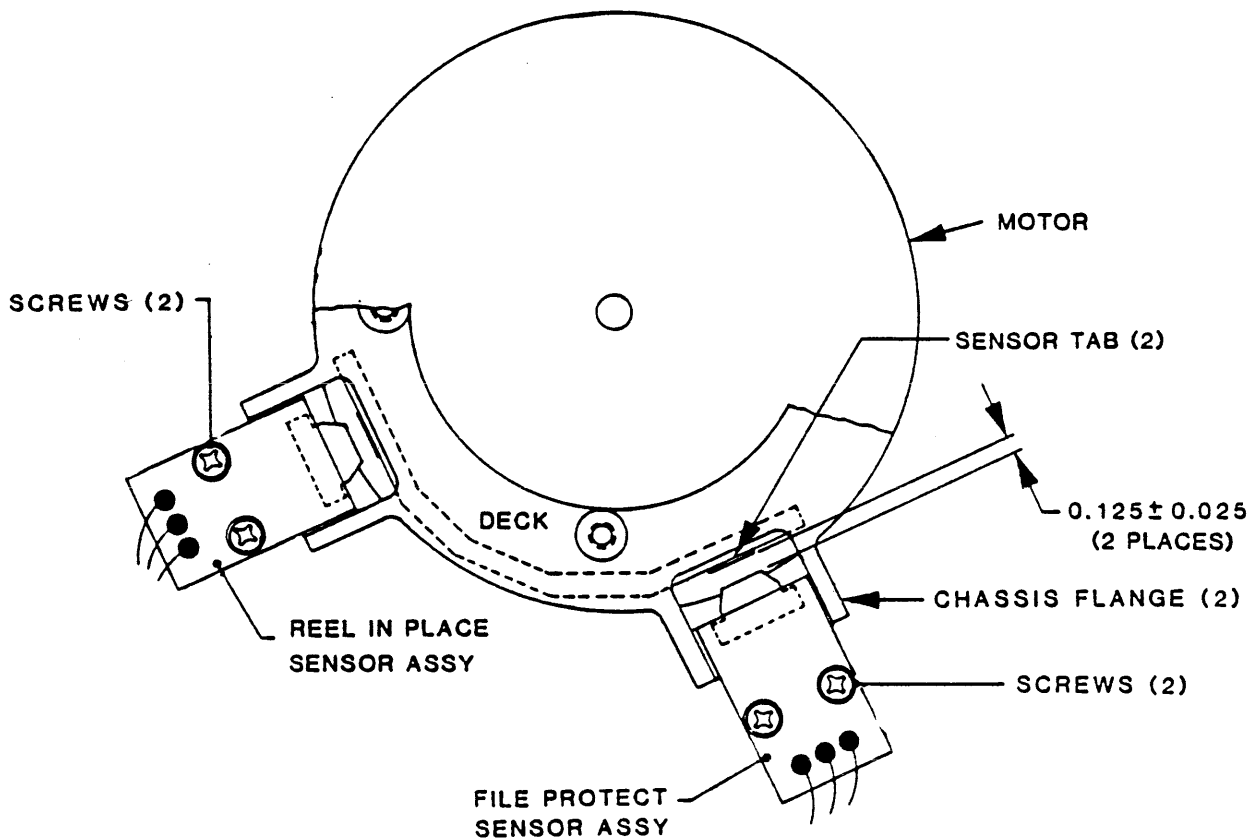

Figure 5-11. File-Protect and Reel-In-Place Sensor Assemblies (Bottom View)

5.3.15 FILE-PROTECT SENSOR ASSEMBLY (Fig. 5-11)

Refer to Figure 6-2 for top view location of Sensor Assemblies.

- A. Remove two Phillips screws and two Spacers (no spacers on Die Cast Deck).
- B. Cut away Tie Wraps, and unplug the Cable from J12 on the interconnect PCBA.
- C. Remove the File Protect Sensor Assembly.

To replace: Reverse removal procedure. Align the Reel In Place Sensor Assembly centered within the chassis flanges and parallel with the Flange Surfaces, and with the specified space between the Sensor Assembly and the Sensor Tab. Torque Mounting Screws to 7 +/-1 inch-pounds.

Enter DIAG and SCAN to DRV ADJ, push enter. Push SCAN until HUB SENSE, push enter. The Hub Lock Solenoid will engage.

Place a write enabled tape on the Supply Hub and rotate hub clockwise until fingers engage and Hub hits Stop. Write Enable LED should light.

If indication is not as described, adjust the position of the sensor assembly until the proper display is achieved.

Remove the Write Enable Ring and verify that when the Hub is rotated to its lock position, the Write Enable LED is off.

5.3.16 SUPPLY ARM LIMIT SENSOR

(Figure 5-12)

- A. Open Top Cover of the Drive per 5.2.2.
- B. Remove 3 phillips screws, and lift off the plate that covers the Supply Arm (See Figure 6-2).
- C. Remove 2 Phillips screws that hold the Limit Sensor to its Mounting Plate.
- D. Raise the Deck to Maintenance Position per 5.2.2.
- E. Unplug Connector P16 from the Interconnect PCBA.
- F. Remove two Cable Clamps from edge of Interconnect Board.
- G. Remove three Screws and move the Interconnect Board and its Mounting Plate out of the way.
- H. Remove tie wraps as necessary, and remove the Sensor.

To replace: Reverse removal procedure.
No adjustment required.

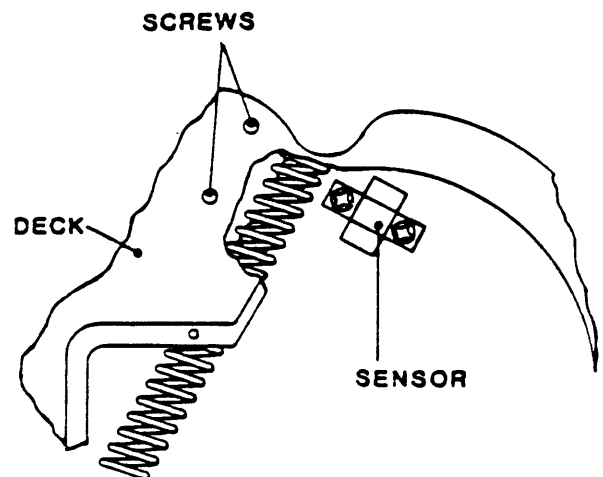

Figure 5-12. Supply Arm Limit Sensor

5.3.17 TAKE-UP ARM LIMIT SENSOR

(Figure 5-13)

- A. Open Top Cover of Drive and raise Deck to Maintenance Position per 5.2.2.
- B. On Sand Cast Deck, remove 2 Phillips screws that hold the Limit Sensor to the Mounting Bracket. On Die Cast Deck, loosen two nuts that hold sensor to casting.
- C. Unplug Connector P15 from the Interconnect Board and remove tie wraps.
- D. Remove pins from connector housing, and pull the cable through the grommet in the Deck.
- E. Remove two bolts and remove the Sensor from Sensor Bracket (on Sand Cast Deck only).

To replace: Reverse removal procedure. Adjust per specifications illustrated. If it is **necessary** to adjust the Sensor Bracket (on Sand Cast Deck only), to access the Screws that hold the Bracket to the Deck, remove the Lower Screw from the Deck Cover Hinge, and open the Deck Cover as far as it will go.

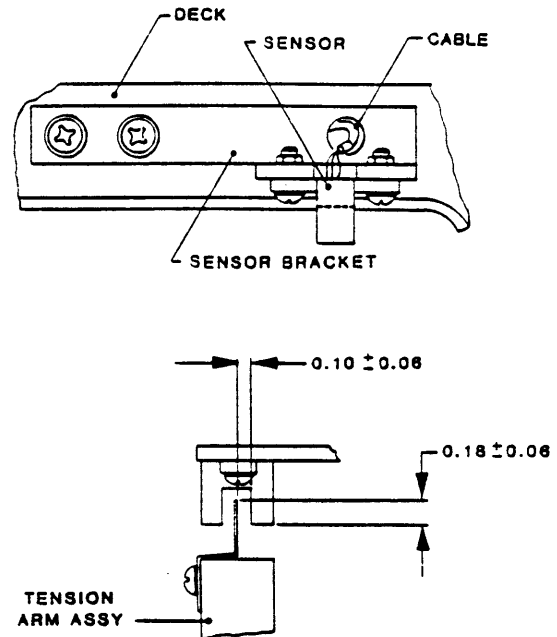

Figure 5-13. Take-up Arm Limit Sensor

5.3.18 12-VDC REGULATOR ASSEMBLY (Fig. 5-14)

- A. Remove 2 Phillips screws that hold the Heat Sink to the Deck (on Sand Cast Deck only). Remove 2 nuts that hold the Heat Sink to the Deck (on Die Cast Deck only).
- B. Unplug connector J1, and remove the Assembly and the Spacer under the Assembly.

To replace: Reverse removal procedure.

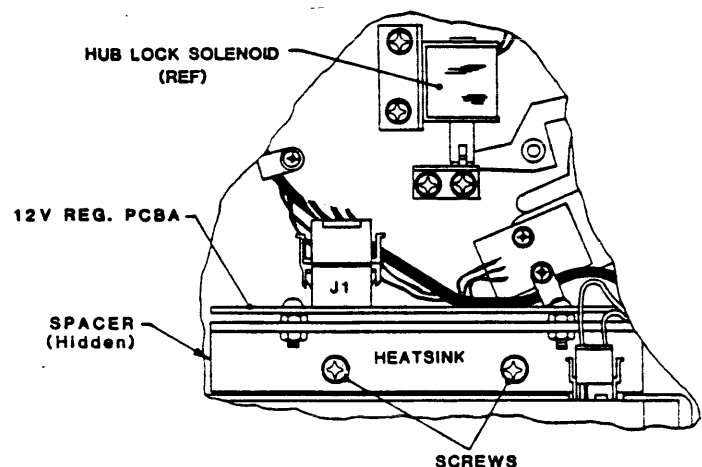

Figure 5-14. 12-VDC Regulator Power Supply

5.3.19 5-VDC REGULATOR POWER SUPPLY (Fig. 5-15)

- A. Lift the Deck and secure it in Maintenance Position per 5.2.2.
- B. Unplug the five connectors indicated in Figure 5-15 from the Power Supply.
- C. Remove four kepsnuts that hold the Power Supply Bracket to the Chassis, and remove Power Supply.

To replace: Reverse removal procedure. Connectors Cables route as follows:

J1 to Power Transformer

J3 to 12VDC Regulator

J4 to Servo Power Amplifier

J5 to Drive Electronics Board

J6 to Mother Board

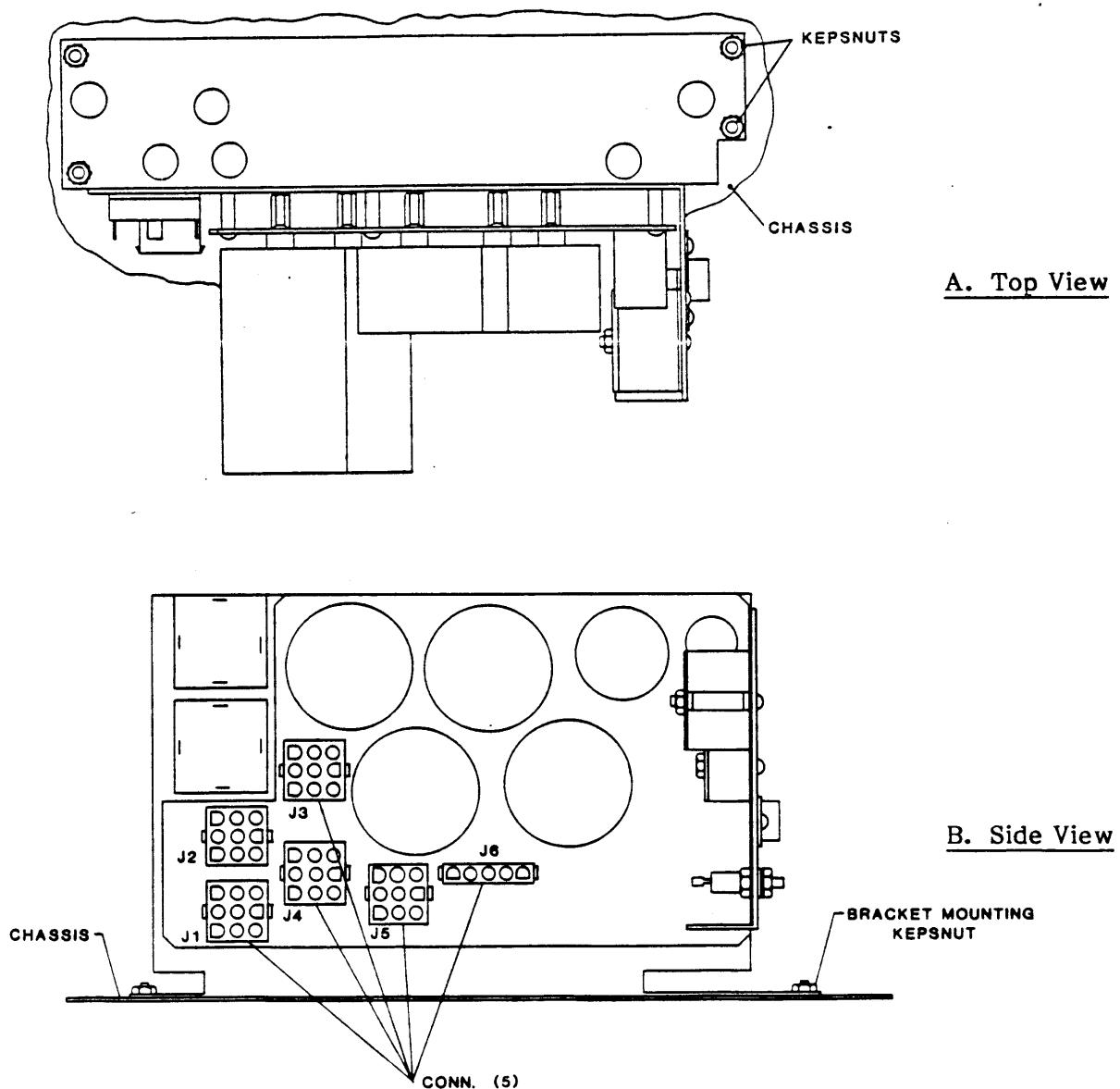

Figure 5-15. 5-VDC Regulator Power Supply

5.3.20 SERVO AMPLIFIER ASSEMBLY

The Servo Amplifier Assembly Figure 5-16) consists of Servo Power Amplifier PCBA P/N 90-07111-XXX mounted on a Heatsink, and Servo Preamplifier PCBA P/N 90-07147-XXX. The Servo Amplifier Assembly is mounted on the inside surface of the Chassis as illustrated in Figure 6-4. Remove the Servo Amplifier Assembly as follows:

- A. Raise the Deck Assembly to Maintenance Position per 5.2.2.
- B. Remove top left transformer lamination securing bolt from Power Transformer.
- C. Unplug Power (J1) , Control (J1) , and Motor Drive (J2) Connectors.
- D. Remove two Phillips Head Screw that hold the Servo Power Amplifier to the side of the Chassis.
- E. Remove two Nuts that hold the Heatsink to the floor of the Chassis.
- F. Lift the Servo Amplifier Assembly up and off the Spacer and Mounting Studs.

To replace: Reverse removal procedure. Adjust RL SERVO per paragraph 5.3.3.

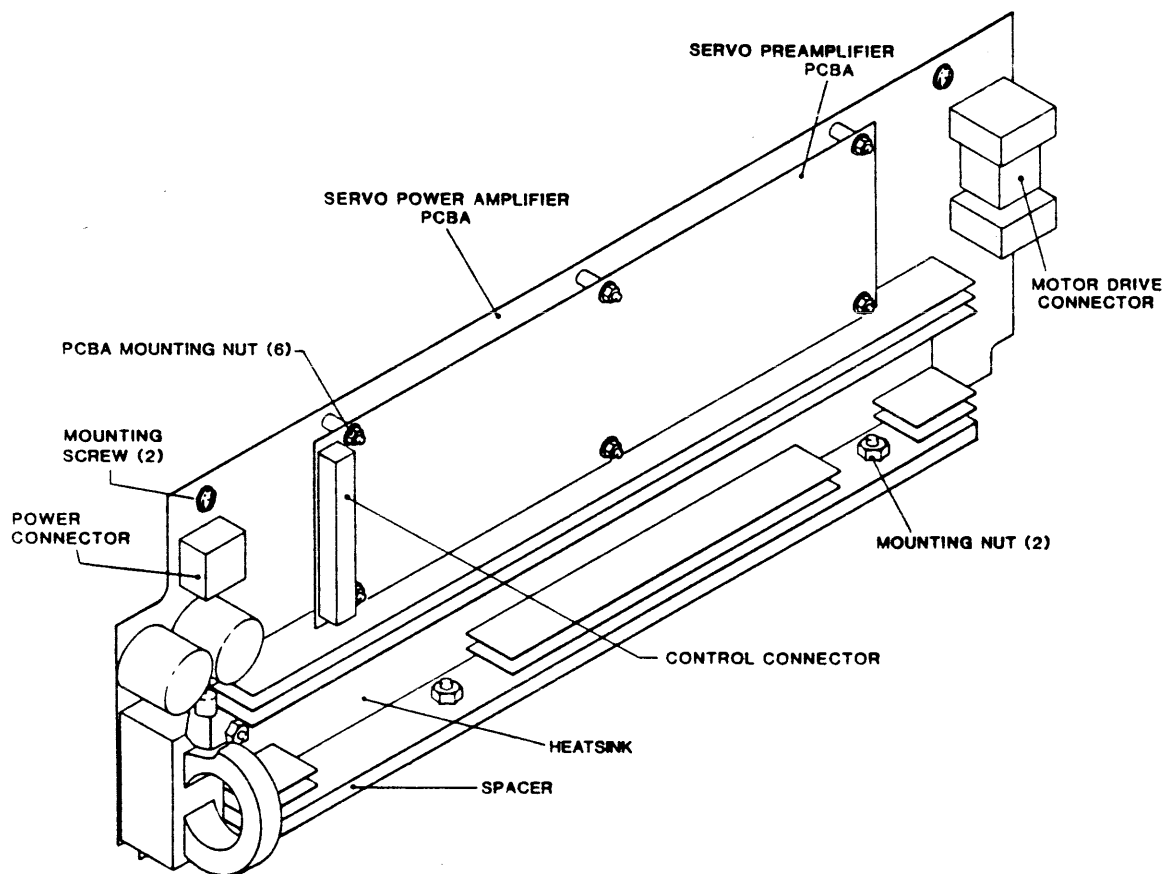

Figure 5-16. Servo Amplifier Assembly

5.3.21 BLOWER ASSEMBLY (Fig. 5-17)

- A. Remove eight Phillips Screws that secure the Blower Assembly Cover to the Blower Assembly, and remove the Cover.
- B. Remove the Take-up Reel Assembly per paragraph 5.3.7 (to access Blower Assembly Mounting Screws).
- C. Unplug the two Reel Motor Connectors.
- D. Unplug the Control Cable Connector from the Power Amplifier.
- E. Remove twelve Phillips Screws that attach the Blower Assembly to the Deck (these screws are accessible from the top of the Deck).
- F. Remove the Blower Assembly.

To replace: Reverse removal procedure.

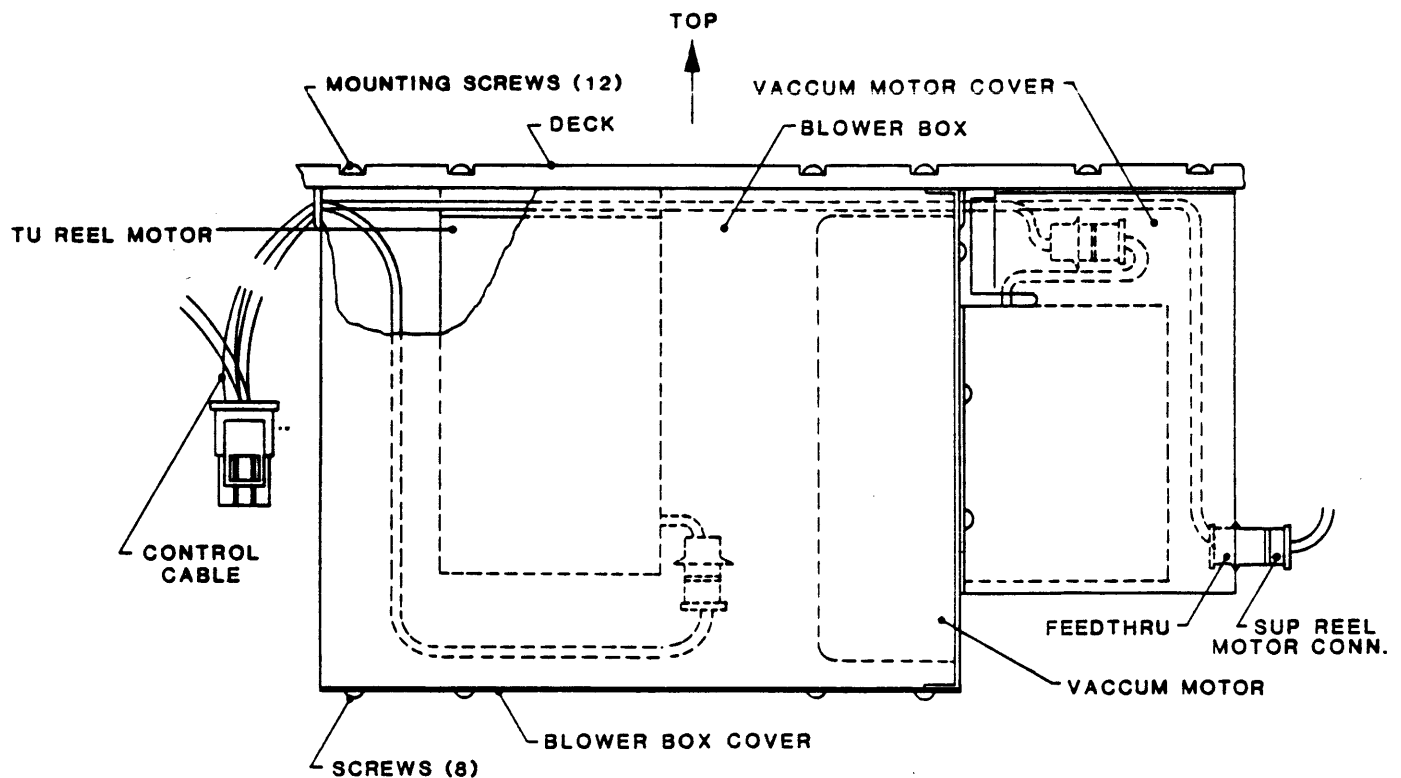

Figure 5-17. Blower Assembly

5.3.22 PANEL ASSY, DOOR MICROSWITCH, AND DOOR LOCK SOLENOID (Fig 5-18)

- A. Remove four Phillips screws (two at each side) that attach the Panel Mount Angle Brackets to the Deck.
- B. Slide the Panel forward, and disconnect wires from AC Power Switch.
- C. Remove Connector P1 from the Operator Control Panel. When the Panel is clear, slide the Panel back away from the Deck.

D. Using a Phillips Screwdriver, as desired, remove the Door Microswitch or the Door Lock Solenoid:

1. For Microswitch, lower the Access Door and remove two Mounting Screw (Go to 3).

2. For Solenoid, remove two Bracket Mounting Screws that attach the Solenoid to the Panel Assembly (Go to 3).

3. Pull Item away from Panel Assembly and disconnect wires. For Solenoid, remove Solenoid from Mounting Bracket.

To replace: Reverse removal procedure. However, when removing the Solenoid, it was necessary to disturb the Hinge that connects the Door to the Panel Assembly. When replacing the Solenoid, before tightening the Mounting Bracket Screws, adjust the Door so that it fits correctly when closed.

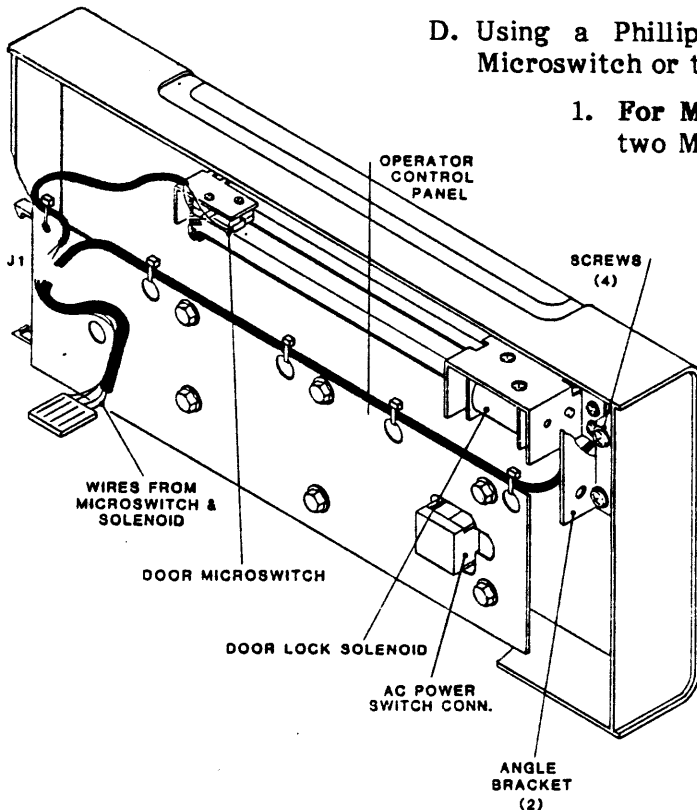

Figure 5-18. Panel Assembly

5.3.23 SUPPLY HUB ASSEMBLY (Figure 5-19)

- A. Open Top Cover per 5.2.2.
- B. Remove two Screws and remove Hub Cap (three on Low Profile Hub).
- C. Remove two Hub Mounting Screws.
- D. Grasp the edges of the Hub firmly and pull upwards.

To replace: Reverse removal procedure.

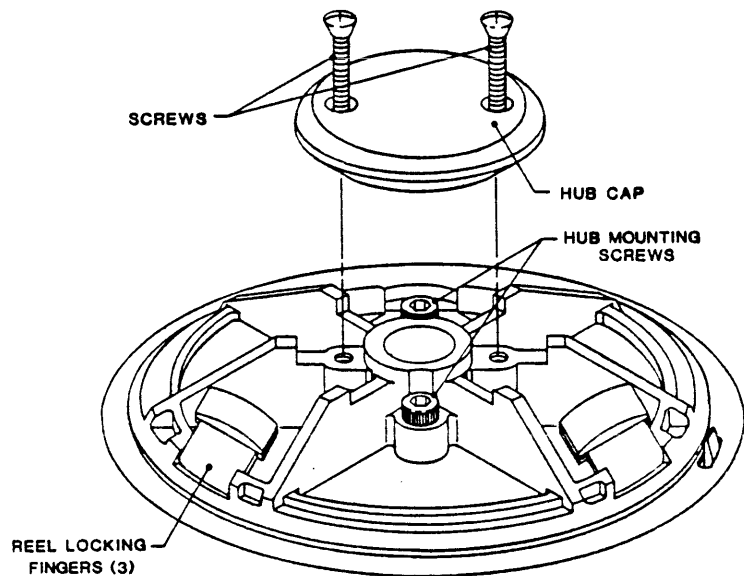

Figure 5-19. Supply Hub Assembly

5.3.24 FLUX GATE (Figure 5-20)

CAUTION: Do not disturb the two Nuts that hold the Flux Gate to the Mounting Block. To do so could throw the Flux Gate out of adjustment.

- A. Set the Drive so that the Buffer Arms are positioned all the way to the Limit Sensors (Buffer Arms fully retracted). This can be done by turning the Drive ON with no tape installed.
- B. Turn the Drive OFF.
- C. Tape a piece of plastic foam over the sensing surface of the Magnetic Head.
- D. Raise the Deck to Maintenance Position per 5.2.2.
- E. Loosen the Set Screw that holds the Spring at the base of the Flux Gate Shaft, and remove the Spring from the hole in the Shaft.
- F. Using Snap Ring Pliers, remove Retainer Ring.
- G. Slide the Flux Gate Shaft out of the Mounting Plate.

To **replace:** Reverse removal procedure.

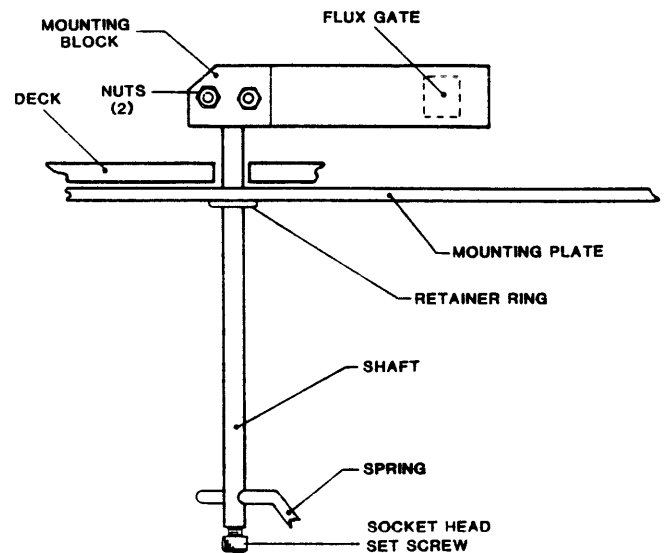

Figure 5-20.
Flux Gate Removal

In the Relaxed position the Flux Gate should make contact at the top and bottom of the Head. In the retracted position, the Flux Gate should touch the casting wall (Sand Casting) or be within .50 inch of casting wall on the Die Casting.

Flux Gate travel may be adjusted by adjusting the position of the spring at the base of the Flux Gate Shaft.

5.3.25 CAPSTAN (Figure 5-21)

- A. Remove Hex-Head Screw and Washer from the center of the Capstan Wheel.
- B. Slide the Capstan Puller P/N 54-00100-001 over the Hub Flange. Tighten Thumb Screw to loosen the Capstan, and remove Capstan.

To **replace:** Reverse removal procedure.

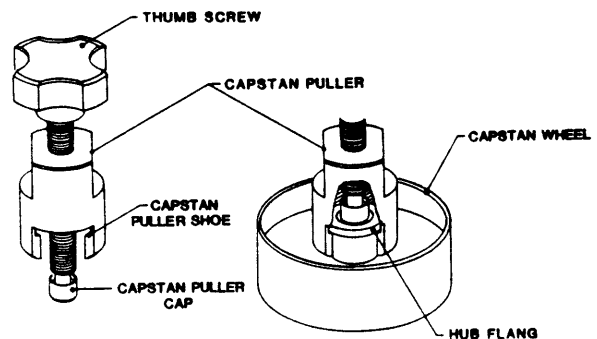

Figure 5-21.
Capstan Removal

CAUTION: Removing Capstan without a Capstan Puller could damage the Capstan. If Capstan is removed without a Puller, it is advisable to replace the Capstan.

5.3.26 CAPSTAN MOTOR

If the Capstan Motor is defective, and the Capstan Motor Mounting Plate is in good condition, replace the Capstan Motor as follows (DO NOT DISTURB THE MOUNTING OR ADJUSTMENT SCREWS FOR THE MOUNTING PLATE): (If the Mounting Plate is damaged, see paragraph 5.3.27.)

- A. Unplug two wires from the Capstan Motor, and unplug the Tachometer Cable from J6 on the Interconnect Board (remove tie wraps as required).
- B. Remove Capstan per 5.3.25.
- C. While supporting the Capstan Motor from below Deck, remove four Mounting Screws that hold the Capstan Motor to the Capstan Motor Mounting Plate.
- D. Lower and remove the Capstan Motor from the Deck.
- E. Calibrate the Capstan Servo per Section 5.5.3.

To replace: Remove Capstan and Capstan Motor Mounting Plate from Spare Capstan Motor Assembly. Reverse removal procedure. If the Capstan Motor Mounting Plate (still mounted on Deck) has not been damaged or disturbed, no adjustment is necessary.

5.3.27. CAPSTAN MOTOR ASSEMBLY (Figure 5-22)

Replace Capstan Motor Assembly ONLY IF CAPSTAN MOTOR MOUNTING PLATE IS DAMAGED OR DISTURBED:

- A. Unplug two wires from the Capstan Motor, and unplug the Tachometer Cable from J6 on the Interconnect Board (remove tie wraps as required).
- B. Remove three Phillips screws that hold the Capstan Assembly to the Deck (Access from the top).
- C. Remove the Capstan Motor Assembly by lowering it through the Deck. Retain the Spacer Washer that was between the Deck and the triangular Capstan Motor Mounting Plate. Note its position.

To replace: Reverse removal procedure. Adjust Capstan as follows:

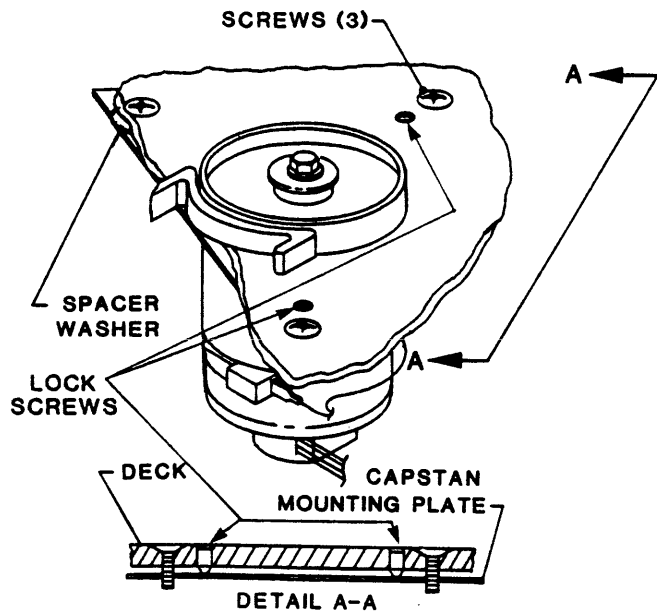

Figure 5-22. Capstan Motor Assembly

Capstan Adjustment

The Capstan Motor is suspended on a triangular Mounting Plate, one corner of which is held firmly in place by a Mounting Screw, while the other two corners are held in place by the clamping action of two other Mounting Screws and the Lock Screws (See Detail A-A). Adjustment of the Capstan consists of adjusting the gap between the two adjustable corners of the Mounting Plate and the Deck Plate. Proceed as follows:

- A. Tighten the Mounting Screw located at the center point of the Buffer Arm path to 8 +/-1 inch-pounds.
- B. Tighten the remaining two Mounting Screws until the Capstan Motor Mounting Plate rests lightly against the two Lock Screws.
- C. From this point, adjust the Capstan per the following Procedure 1 or Procedure 2:

Procedure 1. (The more accurate procedure)

- a. Install and load a write-protected Pericomp Tracking Tape (Pericomp P/N TRK06884).
- b. Using Data Diagnostics in the Diagnostics Menu, select MODE, SPEED, 50 IPS: then, COMMAND, READ. With Front Panel DENSITY Switch, set Density to 800 CPI.
- c. Connect the vertical input of an Oscilloscope to TP 501 on Read Analog Board 9017. Set Oscilloscope controls to: Vert 0.2v/div, Horiz 0.1uSec/div.
- d. Press START/STOP to start the Read Operation selected. The display on the Oscilloscope should be as illustrated:

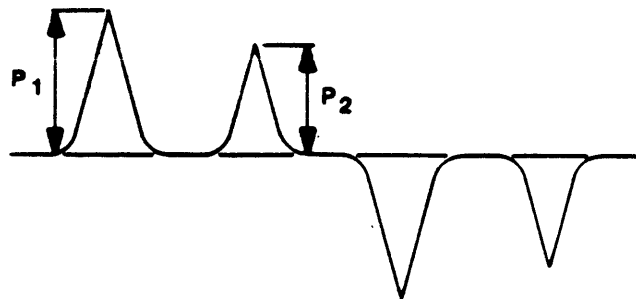

Capstan Tracking Waveform

- e. Adjust the Scope Vertical Gain to obtain a waveform amplitude of the higher peak (P1) of 5 cm. The amplitude of the lower waveform (P2) should be ~80% of the higher waveform.
- f. If waveform fails to meet the specification per Step e, **loosen** one of the **Lock Screws** slightly, and **tighten** the associated **Mounting Screw**, noting the effect on the waveform. If adverse, return Adjustment Screw and Mounting Screw to their original positions and repeat this step with the other Mounting Screw and Adjustment Screw. **NOTE:** During this adjustment, if necessary, readjust Scope Vertical Gain to keep higher peak at 5 cm.
- g. If in Step f the Capstan cannot be adjusted per specification, **Loosen** one of the **Mounting Screws** and **tighten** the associated **Lock Screw**. Then repeat as necessary with the other Mounting Screw and Lock Screw. **NOTE:** During this adjustment, if necessary, readjust Scope Vertical Gain to keep higher peak at 5 cm.
- h. Repeat Steps f and g until correct waveform relationship is obtained.

Procedure 2: (Do this Procedure only if Tracking Tape is not available)

- a. Install and load a reel of tape.
- b. Using the Diagnostic Menu and, while observing the tape as it runs over the Capstan, run tape in Forward/Reverse/Forward Mode at 50 ips.
Tape should run smoothly over the Capstan less than +/-0.01 inch sideward movement. If sideward movement is within tolerance, do all three of the following Substeps. If sideward movement is excessive, start with Substep 3.
 1. Evenly tighten the two Lock Screws.
 2. Recheck sideward movement. If satisfactory, adjustment is complete, omit the remaining steps in this procedure. If sideward movement is excessive, proceed with the following steps.
 3. With tape moving in Fwd/Rev/Fwd Mode, **loosen** one of the **Lock Screws** slightly, and **tighten** the associated **Mounting Screw**, noting its effect on lateral tape movement. If adverse, return Adjustment Screw and Mounting Screw to original positions and repeat this step with the other Mounting Screw and Adjustment Screw.
 4. Repeat Substeps 1 to 3 until adjustment is satisfactory or, If in Substep 3, proper adjustment cannot be obtained, **loosen** one of the **Mounting Screws** and **tighten** the associated **Lock Screw**. Then repeat as necessary with the other Mounting and Lock Screws.
 5. Calibrate the Capstan Servo per Section 5.5.3.

5.3.28 BOT/EOT SENSOR ASSEMBLY (Fig. 5-23)

- A. Raise the Deck Assembly to Maintenance Position per paragraph 5.2.2.
- B. **Noting orientation of Connector in Receptacle**, unplug the Connector from J9 on the Interconnect Board (Remove Tie Wraps as required).
- C. **Noting wire color orientation**, using a small common screwdriver, remove the pins from the cable connector.
- D. Remove three Phillips Screws from Plate on which the Interconnect Board is mounted, and move the Plate and Interconnect Board out of the way.
- E. Remove two Phillips Screws that hold the Sensor in place.
- F. Remove the Sensor and pull wires through the hole in the Deck.

To replace: Reverse removal procedure: Reconnect pins with wire color oriented as illustrated, and as noted in Step C. Plug Connector into Receptacle properly oriented as noted is Step B.

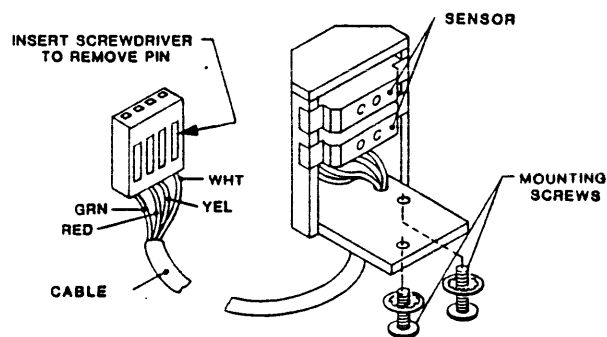

Figure 5-23. EOT/BOT Sensor Assembly

5.3.29 TAPE-IN-CHANNEL EMITTER AND TAPE-IN-CHANNEL SENSOR ASSEMBLIES (Fig. 5-24)

- A. Lift the Deck Assembly and latch it in Maintenance Position.
- B. To remove Tape-In-Channel Emitter Assembly only:
1. Unplug Connector J10 from the Interconnect Board.
 2. Using a small common screwdriver, remove the two Pins from the Connector Housing. Note their positions.
 3. Remove two Cable Clamps from edge of Interconnect Board.
 4. Remove the three screws securing the Interconnect Board Mounting Plate to the Deck. Pull the Interconnect Board and its Mounting Plate away from the Deck.
 5. Cut the Tie Wraps that hold the two wires in the Harness Assembly.
 6. Remove the Emitter Assembly Mounting Screw through the opening provided by removal of the Interconnect Board.
 7. Remove the Emitter Assembly through the top of the Deck, bringing the two wires up with the Assembly: Push each Connector Pin through the hole in the Deck one at a time.
- C. To remove Tape-In-Channel Sensor Assembly only:
1. Unplug J11 from the Interconnect Board.
 2. Do Steps B.2 thru B.5 above.
 3. Remove the Sensor Assembly Mounting Screw through the opening provided by removal of the Interconnect Board.
 4. Cut the Tie Wraps that hold the two wires in the Harness Assembly.
 5. Pull the Sensor Assembly through the top of the Deck, pushing the wires through the opening one at a time.

To replace: Reverse removal procedure. Insert a 2-inch straight piece of wire into the holes provided in the Sensor and Emitter Assemblies, and align the Emitter with Sensor Assemblies by pointing the two wires directly at one another. Then, tighten the Assembly Mounting Screw to 3.5 +/-0.5 inch pounds.

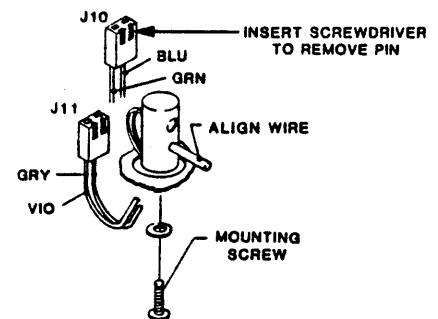

Figure 5-24.
Tape-In-Channel
Emitter Assembly
and Sensor Assembly

5.3.30 VACUUM MOTOR ASSEMBLY (Figure 5-25)

- Remove the Blower Assembly per paragraph 5.3.21.
- Remove four Phillips screws that hold the Vacuum Motor Cover to the Blower Box.
- Lift the Vacuum Motor Cover from the Blower Box, disconnect the Feed thru Connector from the Vacuum Motor Cover, and remove the Vacuum Motor Cover.
- Unplug the Vacuum Motor Connector.
- Remove four Phillips Screws that hold the Vacuum Motor to the Blower Box
- Cut Tie Wraps and remove Vacuum Motor Assembly from the Blower Box.

To replace: Reverse removal procedure.

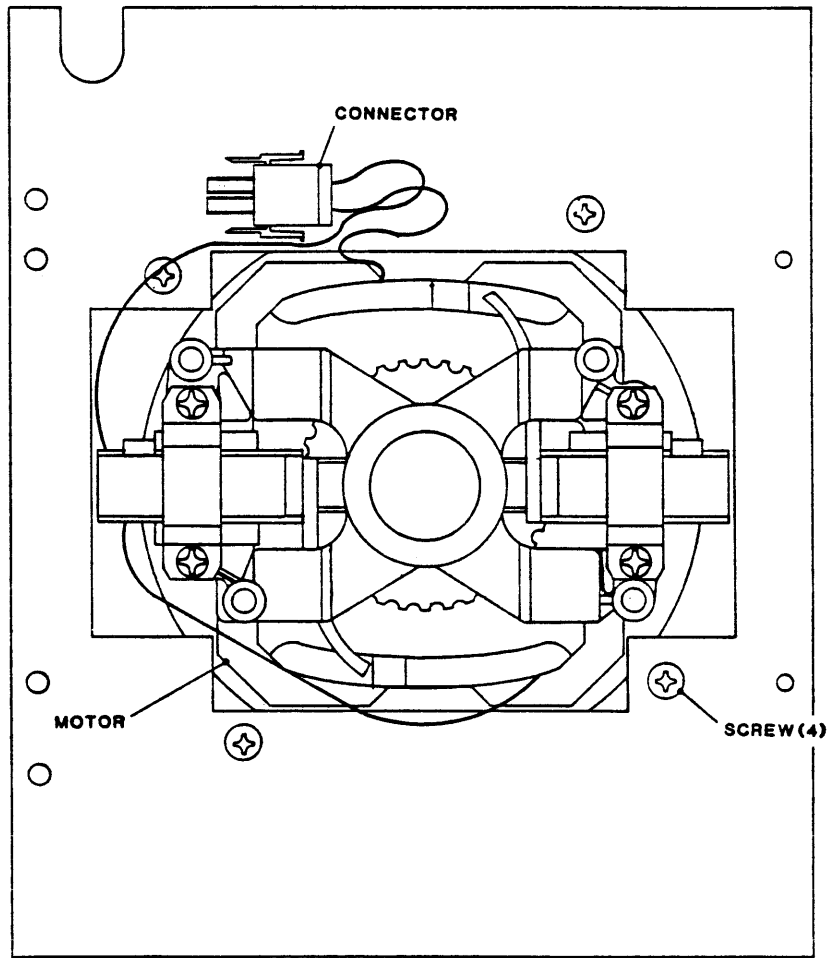

Figure 5-25. Vacuum Motor Assembly, Shaft End View (Cover Removed)

5.3.31 SUPPLY REEL MOTOR ASSEMBLY (Figure 5-26)

- A. Remove Supply Hub Assembly per paragraph 5.3.23.
- B. Remove four Phillips screws that attach The Reel Motor to the Deck.
- C. Unplug the Reel Motor Connector and remove the Reel Motor Assembly.
- D. Remove Collet from Reel Motor Assembly and transfer to new Reel Motor Assembly.

To replace: Reverse removal procedure. Adjust Collet with Collet Height Adjustment Tool P/N 54-00173-001 and Height Adjustment Tool 54-00171-001:

- a. Mount the Tool on the Collet. Tighten the Tool Mounting Screws.
- b. Slide the Collet and Tool onto the Motor Shaft. Set up Height Adjustment Tool per paragraph 5.4.2.1 (B), steps 1 through 3.
- c. Position the Height Gauge Foot on the Collet Tool indicator button.
- d. Turn the Collet Tool adjusting screw until the indicator reads between +0.5025 and +0.5045.
- e. Tighten the Collet Screw, and remove the Tool.
- f. Replace Supply Hub.

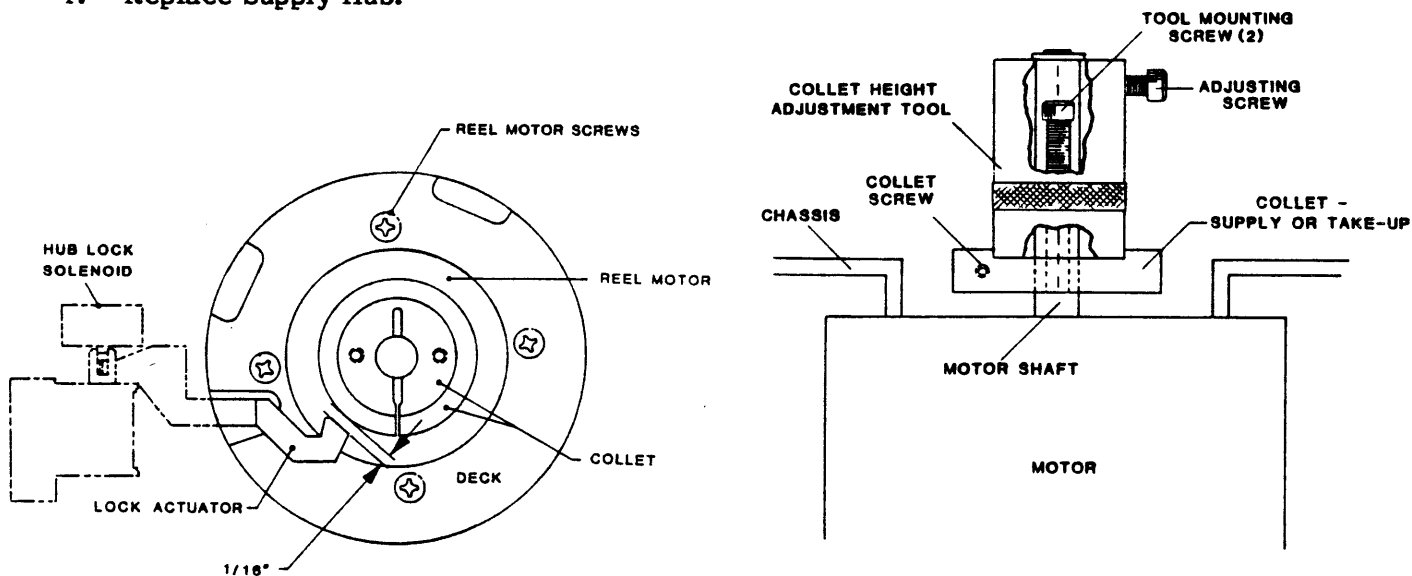

Figure 5-26. Supply Reel Motor Assembly

5.3.32 TAKE-UP REEL MOTOR ASSEMBLY

- A. Remove Take-up Reel Assembly per paragraph 5.3.7.
- B. Lift Deck Assembly and latch it in Maintenance Position.
- C. Remove eight Phillips Screws and remove Cover from Blower Box.
- D. Remove four Phillips Motor Mounting Screws (same as in Fig 5-26) and lower the Reel Motor enough to access the Motor Connector inside the Blower Box.
- E. Disconnect Motor Connector, and remove the Reel Motor.

To replace: Reverse removal procedure. Adjust Collet per 5.3.31, except set the indicator reading to +0.9455 to +0.9475.

5.3.33 MAGNETIC HEAD ASSEMBLY (Figure 5-27)

- A. Remove two Phillips head screws and remove Card Cage Cover.
- B. Unplug Erase Cable from the Read/Write Digital Board (9060) (Ref Fig. 6-5).
- C. Lift Deck Assembly to Maintenance Position per 5.2.2.
- D. Cut the tie wraps that secure the Erase Cable.
- E. Remove the Read Pre-amplifier per paragraph 5.3.5.
- F. Unlatch and lower the Deck Assembly.
- G. Open the Top Cover per 5.2.2 and brace it open.
- H. Open the Tape Path Cover and pull the Erase Cable through the Deck.
- I. Disconnect the Write Cable from the Magnetic Head.
- J. With a 7/64-inch Hex Wrench, remove the screw that holds the Magnetic Head, and remove the Magnetic Head.
- K. Retain the Shim(s) and reinstall under the new head.

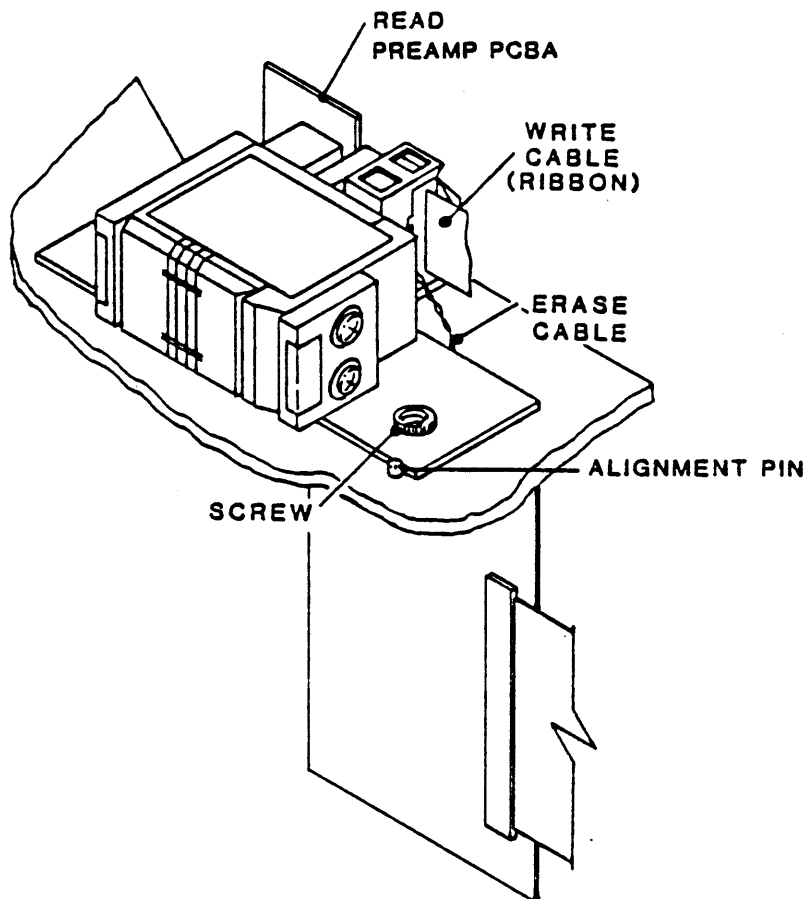

Figure 5-27.
Magnetic Head Assembly and
Read Pre-amplifier PCBA

To replace: Reverse removal procedure. Be sure that the Magnetic Head is pushed tightly against the Alignment Pin and the point of the Skew Adjustment Screw is seated in the alignment hole in the Guide Plate before tightening the Hex Screw that holds the Head Plate, and that Shim(s) are properly aligned under the Head Plate. Adjust Read Skew per paragraph 5.4.2.9.2, Step F. Check Tracking per paragraph 5.4.2.9.2, Step G.

5.3.34 TAPE GUIDE REPLACEMENT (Figure 5-28)

Special Tool Required: Alignment Tool P/N 54-00103-001.

- A. Using a Hex Wrench, remove Mounting Screw and the applicable Tape Guide, retaining Shims.
- B. Install new Tape Guide with the Shims in place, but leave Mounting Screw loose.
- C. Align the Tape Guide by inserting the pins on the Alignment Tool into the holes in the top of both Tape Guides as illustrated. The Alignment Pins should insert all the way into the holes in the Tape Guides, and the Access Holes in the Tool should align with the Tape Guide Mounting Screws.
- D. Tighten the Mounting Screw by inserting the Hex Wrench through the Access Hole in the Alignment Tool. Torque screw to 18-20 in-lbs.

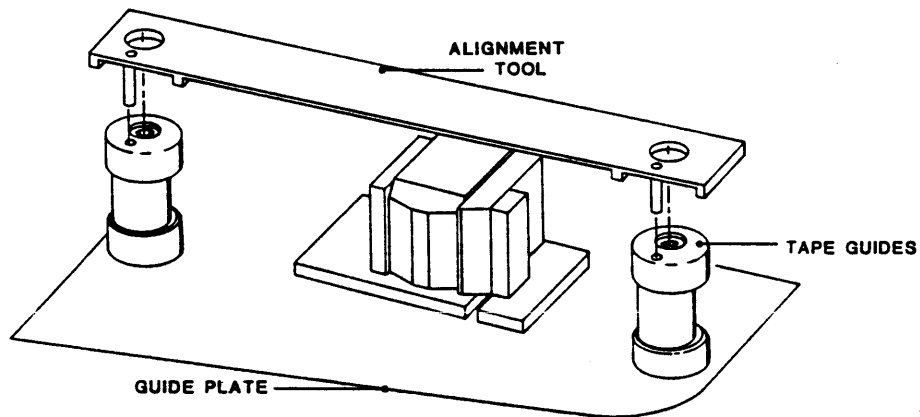

Figure 5-28. Tape Guide Alignment

5.4 ADJUSTMENTS

5.4.1 PRELIMINARY CHECKOUT

Power Supply Check: Verify Power Supply operation as follows:

- A. Raise the Deck Assembly to Maintenance Position per 5.2.2.
- B. Disconnect Power Connectors P4 from the Drive-Electronics PCBA and P1 from the Servo Power Amplifier PCBA.
- C. Connect the AC Power Connector to the Drive and an AC outlet, and turn on AC power.
- D. Using a digital voltmeter, verify voltages at Power Connectors as follows:

<u>Conn</u>	<u>Pin</u>	<u>Voltage</u>	<u>Tolerance</u>	<u>Conn</u>	<u>Pin</u>	<u>Voltage</u>	<u>Tolerance</u>
P4	1	+5	+0.25/-0.05	P4	7	-50	+/-7.5V
P4	2	+12	+/-0.5	P4	8	+50	+/-7.5V
P4	3	-12	+/-0.5	P4	9	+24	+/-4.0V
				P3	1	-24	+/-4.0V

- E. Turn AC power off and Wait about 10 seconds; then reconnect Power Connectors P4 and P1 to Drive Electronics and Servo Power Amplifier PCBAs.

5.4.2 BUFFER ARMS ADJUSTMENT

5.4.2.1 BUFFER ARM ROLLERS & FIXED ROLLERS HEIGHT ADJUSTMENT (Fig. 5-29)

- A. **General:** Height adjustment of the Fixed Rollers and Buffer Arm Rollers require the use of special Height Adjustment Tool Kit P/N 54-00171-001. Whenever one of these components is replaced, or its height disturbed, it must be checked for proper height and adjusted as necessary.

The Height Adjustment Tool Kit consists of three pieces; a Surface Plate that rests on the Deck Assembly at three points, and spans over the two Fixed Rollers and the two Buffer Arm Rollers at a specified height, and a Digital Height Gauge with a base that may be moved across the Surface Plate. The Rollers must be adjusted vertically to the proper height.

- B. **Adjusting Buffer Arm Tape Roller Height:** Adjust the applicable Buffer Arm Tape Roller as follows:

Special Items Required: Set of Shims P/N 98-00208-001. These are of the following thicknesses: .003/.005/.010 inch.

1. Inspect and clean as required the Surface Plate, Height Gauge and the three mounting surfaces on the topside of the Deck. The surfaces are to be free of dirt and other matter.
 2. Place the Surface Plate on the topside of the Deck, insuring that the two locating pins are in the holes provided on the Deck. Place the Height Gauge on the Surface Plate to begin tape path alignment. Verify distance from 0.500" spacer to top of split guide (supply side) is within tolerance (.7745 +/- .0010). See Figure 5-29.
 3. Position Height Gauge so indicator pad contacts the top surface of the split tape guide on the supply side of the Head. Zero the Height Gauge. See Figure 5-29. Raise and lower deck gently until digimatic reading repeats to zero. Check the height of Collets and record the readings on data sheet. Re-set Collets to meet the required dimension. Torque the Collet Screw to 19-21 in-lbs. Re-assemble Supply Hub and Take-up Reel and torque the screw to 18-20 in-lbs.
 4. Set height of Tension Arms by placing the required combinations of Shims as required between bottom of Arm Clamp and Pivot Assembly to obtain a Height Gauge reading of -0.2955 to -0.2975 Tighten the bolts to 16 in-lbs. Note: Any time Tension Arm is removed for shimming, Buffer Arm calibration is required. For Buffer Arm calibration see section 5.4.2.3.
- C. **Adjusting the Fixed Tape Rollers:** With the Height Gauge still mounted as described above (Step B. 1 thru 3), check, and as necessary adjust either Fixed Tape Roller as follows:

Special Items Required: Set of Shims P/N 98-00209-001. These are of the following thicknesses: .001/.003/.005/.010 inch.

1. Set height of Fixed Guides by placing different combinations of Shims, as required, between the Bearing and Fixed Guide Post to obtain a Height Gauge reading of -0.2505 to -0.2525. Tighten screws to 7-9 in-lbs.
- D. Adjust Tape Guides per paragraph 5.3.34.
- E. Recalibrate the Buffer Arms per paragraph 5.4.2.3.

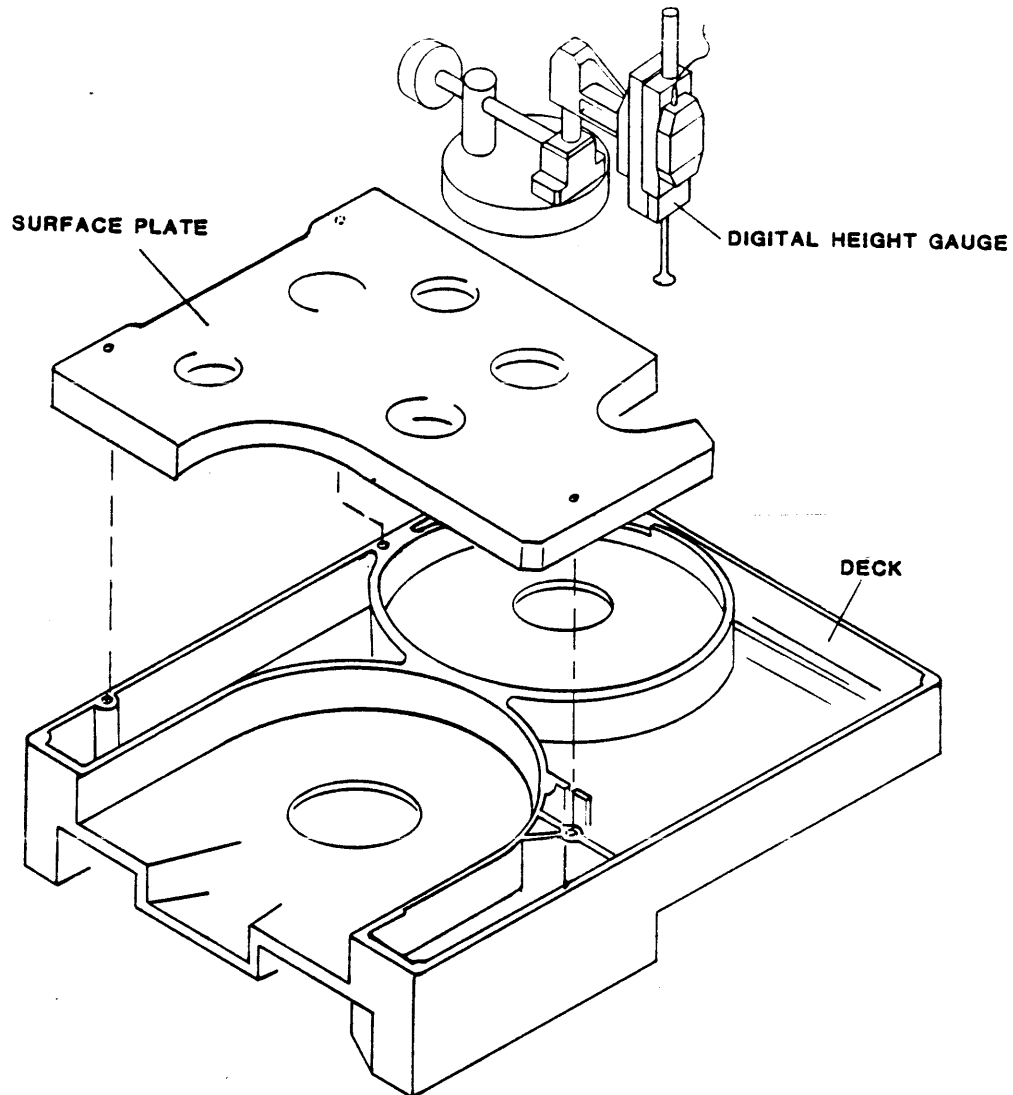

Figure 5-29. Tape Rollers Height Adjustment

5.4.2.2 CAPACITIVE DISK HEIGHT ADJUSTMENT

Use this procedure to adjust the distance of the Capacitive Disk from the Position Sensor PCB if the disk has been removed or replaced with the deck in the maintenance position per paragraph 5.2.2 and AC power is turned OFF.

- A. Using a 0.015-inch Plastic Feeler Gauge, measure the spacing between each Capacitive Disk and its respective Position Sensor PCBA (See Figure 5-8). The Feeler Gauge should slide freely but snugly between the disk and the PCBA.
- B. If spacing is not correct, loosen the Set Screw on the Capacitive Disk Hub, and adjust the spacing between the Capacitive Disk and the PCBA as required. Retighten the Set Screw.
- C. Calibrate the Buffer Arms per paragraph 5.4.2.3.

5.4.2.3 BUFFER ARM CALIBRATION

Throughout the Buffer Arm calibration and check procedure, while the Buffer Arm voltage is being displayed on the front panel, there may be jitter in the last digit. The jitter is ACCEPTABLE if it stops as the arm is moved slightly in one direction or the other.

5.4.2.3.1 SAND CAST DECK

Note: If the drive is equipped with 90-09069-104 Retract Assemblies, make sure that Jumpers W1 and W2 are NOT installed. There will be no tape loaded during this test. Relax the Buffer Arms via BUF ARMS portion of the DRV ADJ diagnostic.

- A. Turn on AC power.
- B. Enter diagnostics mode by pressing DIAG, then ENTER. Press SCAN three times. The display will read: DRV ADJ. Press ENTER, the display will read: BUF ARMS. Press ENTER. The display will indicate: RELAXING while the arms relax and the gain of the Position Sensors is automatically calibrated. When complete, the display will indicate: TAKE-X.X (X.X = voltage reading).
- C. Install the Relaxed Position Tool P/N 54-00631-001 or 54-00633-001 and note the display reading. Remove the tool and adjust the Stop so that the same reading is achieved.
- D. With the Buffer Arms still relaxed, raise the deck. Check that the gap between the Drive Pin in the Retract Motor Shaft and the Pivot Pin on the Capacitive Disk Assembly is 0.15 +/-0.05 inch (See Figure 5-30). Check both the Supply and Take-up Arms. If either is out of tolerance, adjust as follows:

CAUTION: Overtightening Cam Set Screw can damage the Cam. Do not overtighten Cam Set Screw.

Locate the Microswitch and the Cam on the bottom of the Retract Assembly. Loosen the Cam Set Screw and rotate the Cam on the Motor Shaft so that the Microswitch Actuator is just entering the notch in the Cam. Tighten the Cam Set Screw to 3.5 +/-0.5 inch-pounds.

NOTE: If the Cam Set Screw can not be accessed in the relaxed position, perform the following procedure:

Estimate the amount of adjustment required to bring the gap into tolerance. Press the DIAG switch and watch as the arms are retracted until the Cam Set Screw is accessible. When the Set Screw is in an accessible position, turn the AC power off. Loosen the Cam Set Screw and make the adjustment as estimated earlier. Tighten the Cam Set Screw to 3.5 +/-0.5 inch-pounds. Repeat steps A, B and D to re-check the adjustment.

- E. Press the START/STOP switch. The DIAG light will start to flash, indicating the reference voltage to the position sensors have been set to the default value.
- F. Manually move the Take-up Arm to its zero position, and install the Take-up Zero Position Tool (99-00633-002). Verify a display reading of exactly 0.0. If not, adjust per step K before continuing. If correct, skip to step L.
- G. Bring the Take-up Arm to its relaxed position and install the Take-up Arm Relaxed Position Tool (99-00633-001). The display must show -2.5 to -2.7. If not, adjust per step K before continuing. If correct, skip to step L.
- H. Note the exact reading. Remove the tool, and adjust the Relaxed Position Set Screw until the exact same reading is achieved.

- I. Push SCAN. The display shows SUPP +/-X.X. Repeat step F above for the Supply Arm, using Supply Zero Position Tool (99-00631-002). The same zero position voltage applies.
- J. Bring the Supply Arm to its relaxed position and install the Supply Arm Relaxed Position Tool (99-00631-001). The display must show -2.4 to -2.6. If not, adjust per step K before continuing. If correct, skip to step L.
- K. If either of the readings for a particular arm is out of tolerance, that arm must be adjusted as follows:
 1. To adjust the zero point of the arm, loosen the Lock Bolt that clamps the arm to its Pivot Shaft and rotate the shaft until the reading is within specification with the arm in the zero position. Retighten the Clamp Bolt to 13.0 +/-1.0 inch-pounds. Alternatively if a Height Adjustment Tool is not available, the Capacitive Disk may be rotated while maintaining the height adjustment per paragraph 5.4.2.2.
 2. Check the arm height per paragraph 5.4.2.1.
 3. Move the arm to its relaxed position. If the reading is out of tolerance the distance of the Capacitive Disk from the Position Sensor PCB must be adjusted. To do this, raise the deck and locate the Capacitive Disk for the arm to be rotating the disk on the shaft. If the reading was too low the disk should be moved closer to the Position Sensor PCB. If it was too high, the disk should be moved farther away. After the height has been adjusted, go back to step 1 and re-check the zero position.
- L. Once the arms have been adjusted to within tolerance, press ENTER. The display will indicate: CONFIRM? Press ONLINE to start the electronic calibration phase. The display will indicate: RELAXED? Make sure both arms are resting on their Mechanical Stops and press ENTER. The drive will automatically calibrate the gain of the Position Sensors. After about 3 seconds the display will indicate: TLIM X.X. If the drive failed to calibrate one of the arms, the display will read TAK ARM? or SUP ARM?, indicating which arm failed to adjust. If so, press DIAG and go back to step J and adjust that arm.
- M. With the display showing TLIM X.X, move the Take-up Arm to the TLIM position, by placing the Take-up Arm TLIM Tool (99-00629-001) between Fixed Roller and Capstan. At the TLIM position, the Select LED must be ON, indicating that the voltage is within acceptable limits. Push ENTER. Remove the TLIM Tool.
- N. The display will now show SLIM X.X in the display. Move the Supply Arm to the SLIM position, by placing the Supply Arm SLIM Tool (99-00619-001) on the Fixed Roller. Again, the Select LED must be ON. Push ENTER. The display will show RETRACT, then BUF ARMS. Remove the SLIM Tool.

5.4.2.3.2 DIE CAST DECK

Note: If the drive is equipped with 90-9069-004 retract assemblies, make sure that jumper **W1 IS** and **W2 IS NOT** installed. There will be no tape loaded during this test.

- A. Turn on AC power.
- B. Enter diagnostics mode by pressing DIAG, then ENTER. Press SCAN three times. The display will read: DRV ADJ. Press ENTER, the display will read: BUF ARMS. Press ENTER. The display will indicate: RELAXING while the arms relax and the gain of the Position Sensors is automatically calibrated. When complete, the display will indicate: TAKE-X.X (X.X = voltage reading).

- C. With the Buffer Arms still relaxed, raise the deck. Check that the gap between the Drive Pin in the Retract Motor Shaft and the Pivot Pin on the Capacitive Disk Assembly is 0.15 +/-0.05 inch (See Figure 5-30). Check both the Supply and Take-up Arms. If either is out of tolerance, adjust as follows:

CAUTION: Overtightening Cam Set Screw can damage the Cam. Do not overtighten Cam Set Screw.

Locate the Microswitch and the Cam on the bottom of the Retract Assembly. Loosen the Cam Set Screw and rotate the Cam on the Motor Shaft so that the Microswitch Actuator is just entering the notch in the Cam. Tighten the Cam Set Screw to 3.5 +/-0.5 inch-pounds.

NOTE: If the Cam Set Screw can not be accessed in the relaxed position, perform the following procedure:

Estimate the amount of adjustment required to bring the gap into tolerance. Press the DIAG switch and watch as the arms are retracted until the Cam Set Screw is accessible. When the Set Screw is in an accessible position, turn the AC power off. Loosen the Cam Set Screw and make the adjustment as estimated earlier. Tighten the Cam Set Screw to 3.5 +/-0.5 inch-pounds. Repeat steps A, B and C to re-check the adjustment.

- D. Press the START/STOP switch. The DIAG light will start to flash, indicating the reference voltage to the position sensors have been set to the default value.
- E. Manually move the Take-up Arm to its zero position, and install the Take-up Zero Position Tool (99-00634-001). Verify a display reading of exactly 0.0. If not, adjust per step I before continuing. If correct, skip to step J.
- F. With the Take-up Arm in its relaxed position, the display must show -3.2 to -3.4. If not, adjust per step I before continuing. If correct, skip to step J.
- G. Push SCAN. Display shows SUPP +/-X.X. Repeat step E above for Supply Arm, using Supply Zero Position Tool (99-00632-001). The same zero position voltage applies.
- H. With the Supply Arm in its relaxed position, the display must show -2.7 to 2.9. If not, adjust per step I before continuing. If correct, skip to step J.
- I. If either of the readings for a particular arm is out of tolerance, that arm must be adjusted as follows:
1. To adjust the zero point of the arm, loosen the Lock Bolt that clamps the arm to its Pivot Shaft and rotate the shaft until the reading is within specification with the arm in the zero position. Retighten the Clamp Bolt to 13.0 +/-1.0 inch-pounds. Alternatively if a Height Adjustment Tool is not available, the Capacitive Disk may be rotated while maintaining the height adjustment per paragraph 5.4.2.2.
 2. Check the arm height per paragraph 5.4.2.1.
 3. Move the arm to its relaxed position. If the reading is out of tolerance the distance of the Capacitive Disk from the Position Sensor PCB must be adjusted. To do this, raise the deck and locate the Capacitive Disk for the arm to be rotating the disk on the shaft. If the reading was too low the disk should be moved closer to the Position Sensor PCB. If it was too high, the disk should be moved farther away. After the height has been adjusted, go back to step 1 and re-check the zero position.

- J. Once the arms have been adjusted to within tolerance, press ENTER. The display will indicate: CONFIRM? Press ONLINE to start the electronic calibration phase. The display will indicate: RELAXED? Make sure both arms are resting on their Mechanical Stops and press ENTER. The drive will automatically calibrate the gain of the Position Sensors. After about 3 seconds the display will indicate: TLIM X.X. If the drive failed to calibrate one of the arms, the display will read TAK ARM? or SUP ARM?, indicating which arm failed to adjust. If so, press DIAG and go back to step J and adjust that arm.
- K. With the display showing TLIM X.X, move the Take-up Arm to the TLIM position, by placing the Take-up Arm TLIM Tool (99-00635-001) between Fixed Roller and Capstan. At the TLIM position, the Select LED must be ON, indicating that the voltage is within acceptable limits. Push ENTER. Remove the TLIM Tool.
- L. The display will now show SLIM X.X in the display. Move the Supply Arm to the SLIM position, by placing the Supply Arm SLIM Tool (99-00630-001) on the Fixed Roller. Again, the Select LED must be ON. Push ENTER. The display will show RETRACT, then BUFF ARMS. Remove the SLIM Tool.

5.4.2.4 STATIC ARM TENSION CALIBRATION (Figure 5-30)

With the Drive in BUFF ARMS Mode and relaxed per 5.4.2.3.1, Steps A and B:

- A. For each Buffer Arm, using a loop of string (or similar device), attach a static measuring device (such as a spring scale) to the tape guide on the end of the Arm. Using the Static Measuring Device, pull the Arm to the zero position and hold it there. The Measuring Device should indicate 17.5 +/-1.0 ounces.
- B. If Arm tension is out of tolerance, loosen the lock nut on the Spring Tension Adjusting Screw, and rotate the Spring Tension Adjustment Screw as required until the tension is within tolerance.
- C. Tighten the lock nut on the Spring Tension Adjusting Screw.

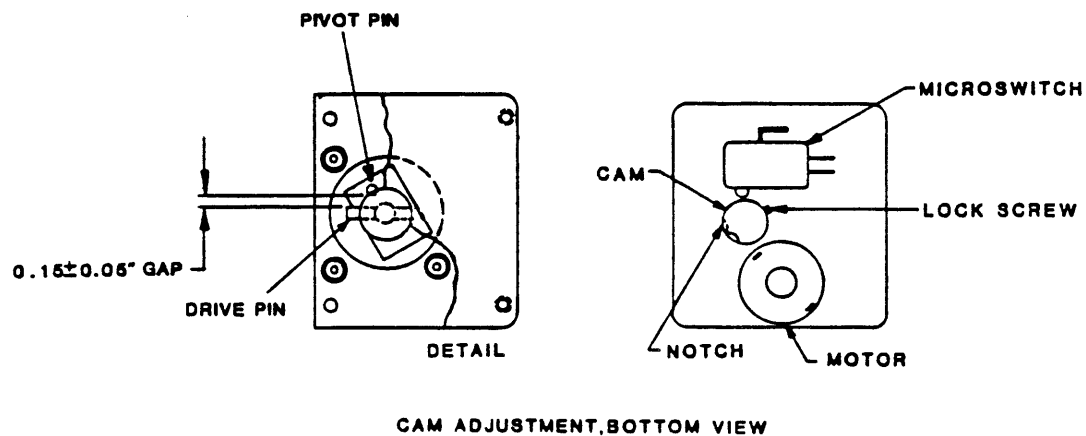
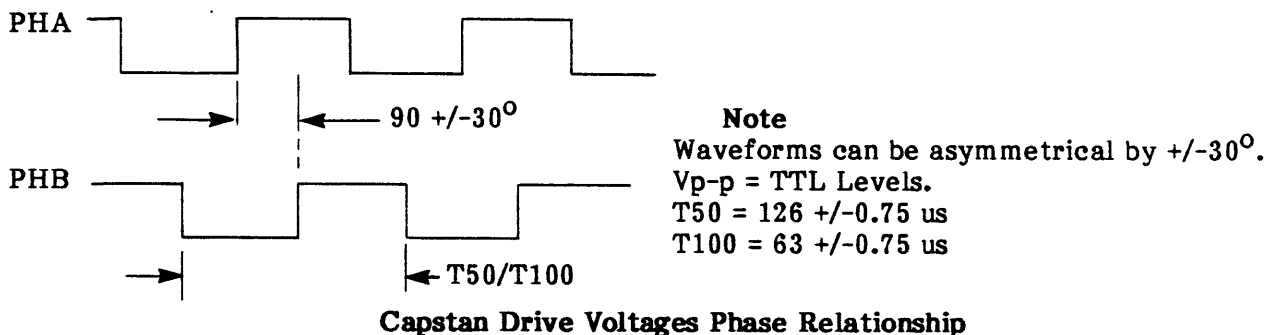

Figure 5-30. Buffer Arms Calibration

5.4.2.5 CAPSTAN CHECK

- A. Turn on AC power.
- B. Press DIAG. Display indicates: DIAG.
- C. Press ENTER. Display indicates: SELFTEST.
- D. Press SCAN. Display indicates: MOTION.
- E. Press ENTER. Display indicates: 50 FWD.
- F. Press ENTER. Capstan should move in forward direction.
- G. On the Drive Electronics Board: connect a dual trace oscilloscope to U37 Pin 2 (PHA), and U37 Pin 3 (PHB). The two signals should be approximate squarewaves 90 \pm 30° out of phase with one another, as illustrated below:



- H. Check time period, T50.
- I. Press START/STOP. Capstan should stop motion.
- J. Repeatedly press SCAN until display indicates: 100 FWD.
- K. Check time period T100.

5.4.2.6 LOAD TEST

With the Drive in Diagnostic-Motion Mode per paragraph 5.4.2.5, Steps A thru D:

- A. Open the Tape Access Door and insert a 10-1/2 inch Test Reel.
- B. Leaving the Access Door open, Press LOAD. The display should indicate: CLOSE DOOR.
- C. Close the Tape Access Door. The Drive should now load with the following sequence:
 1. Display indicates: LOADING.
 2. Supply Hub Solenoid engages.
 3. Supply Hub reverses and locks the reel.
 4. Supply Hub Solenoid disengages.
 5. Vacuum Blowers starts.
 6. Tape threads onto Take-up Reel, and Vacuum shuts off.
 7. Tension Arms engage and apply tension to tape (8.75 \pm 0.5 oz).
 8. Drive searches for Load Point.
 9. Drive reaches Load Point, adjusts the Write Current while shuttling back and forth, then stops at Load Point.
 10. Displays indicates: UNIT X, and Tension Arms move to Zero Point. If Write Ring is installed on Reel, WRITE ENABLE indicator lights.

5.4.2.7 DIAGNOSTIC WITH TAPE LOADED

With a Tape Reel in the Drive, and the Drive in Diagnostic-Motion Mode per paragraph 5.4.2.5:

A. Repeatedly press SCAN and verify the sequence of displays:

<u>Step</u>	<u>Display</u>	<u>Step</u>	<u>Display</u>	<u>Legend</u>
1	50 FWD	8	100 FSS	FWD = Forward
2	50 REV	9	100 RSS	REV = Reverse
3	50 FSS	10	100 FRF	FSS = Forward Start/Stop
4	50 RSS	11	50/100 F	RSS = Reverse Start/Stop
5	50 FRF	12	50/100 R	FRF = Forward/Reverse/Forward
6	100 FWD	13	BURN-IN	F = Forward; R = Reverse
7	100 REV			50 = 50 ips; 100 = 100 ips

- B. Repeat Step A., but after each substep, press ENTER, and verify that the Drive does the operation indicated by the display: for each test, allow the Drive to run for several seconds, then press START/STOP. Then do the next substep.
- C. Repeatedly press SCAN until display indicates: 100 FWD. Press ENTER and let the tape run to the end of tape. Verify that the display indicates: EOT.
- D. Press DIAG twice. Display indicates: DIAG, then UNIT X.
- E. Press RWND/UNLD. The tape should run to the beginning of tape, and the display should indicate: LOAD PT.

5.4.2.8 CALIBRATION, MECHANICAL

Hub Lock Solenoid Adjustment: (Figures 5-4 and 5-26)

With AC power off, adjust the Hub Lock Solenoid as follows:

- A. Remove Supply Hub per paragraph 5.3.23.
- B. Raise the Deck to Maintenance Position per paragraph 5.2.2.
- C. Referring to Figure 5-4, loosen the two Solenoid Bracket Mounting Screws until the Solenoid Body can be moved freely: **Do not remove screws.**
- D. Position the Solenoid Body so that the Plunger is centered in its channel and can move freely over its full range of travel while moving the Lock Actuator.
- E. Holding the Solenoid Body firmly in its location on the Deck, tighten the two Solenoid Bracket Mounting Screws. Verify that the Solenoid Plunger still moves freely in the Solenoid Bore. Repeat Steps C, D And E if necessary. Torque Mounting Screws to 13.0 +/-1.0 inch-pounds.
- F. Loosen the two Solenoid Mounting Screws until the Solenoid can be moved freely on the Bracket.
- G. Push the Solenoid Plunger all the way into the Solenoid and, while holding it there, adjust the Solenoid until the Lock Actuator is at 0.062 +/-0.030 inch (1/16 inch) from the Collet as illustrated (Figure 5-26).
- H. Holding the Solenoid firmly against the Solenoid Mounting Bracket, Tighten the Solenoid Mounting Screws to 13.0 +/-1.0 inch-pounds.
- I. Loosen the two Stop Bracket Mounting Screws.
- J. Move the Stop Bracket until the Lock Actuator aligns with the arc of the opening in the Deck for the Reel Motor (+/-0.30 inch).

- K. Holding the Stop Bracket firmly against the Deck, tighten the Mounting Screws to 13.0 +/- 1.0 inch-pounds.
- L. Verify that the Hub rotates freely without contacting the Actuator.
- M. Enter DIAG and SCAN to DRV ADJ. Enter and SCAN to HUB SENSE, push enter. The Hub Lock Solenoid should engage. Verify that clockwise rotation of the Hub engages the fingers and that the Actuator locks the Hub.

5.4.2.9 CALIBRATION AND SET-UP, ELECTRONIC

A. General:

All Electronic Calibration procedures and most of the Electronic Set-up procedures require that the Calibration Jumper on the Drive Electronics Board be placed in CALIBRATE position. The following Preparation Procedure describes installing the Calibration Jumper.

NOTE: The Set-up Procedures for UNIT NUMBER and DEFAULT DENSITY do not require the Calibration Jumper to be placed in ENABLE Position. These procedures are described in Section II.

B. Preparation:

1. Turn AC power on. The Readout displays "TESTING", then "UNIT X".

CAUTION

Turning AC power OFF or ON while the Calibration Jumper is in ENABLE position could cause loss of programmed parameters on the Drive Electronics Board. Such a loss could require re-entry of parameters by Kennedy service personnel. Therefore, during the following calibration procedures, **DO NOT TURN AC POWER OFF UNTIL CALIBRATION JUMPER HAS BEEN REPLACED TO ITS ORIGINAL (DISABLE) POSITION.**

2. Remove the Bolts on the sides of the unit, raise the Deck Assembly and, using the Support Bar, secure the Deck Assembly in Maintenance Position as shown in Figure 2-6 or 2-7 (Section II).
3. On Drive Electronics Board (Figure 5-31), move the Calibration Jumper to ENABLE Position.
4. Unlatch Support Bar and lower the Deck Assembly.
5. Install a reel of tape in the Drive, set the Drive to Diagnostic-Motion Mode, run tape to BOT by pressing LOAD.

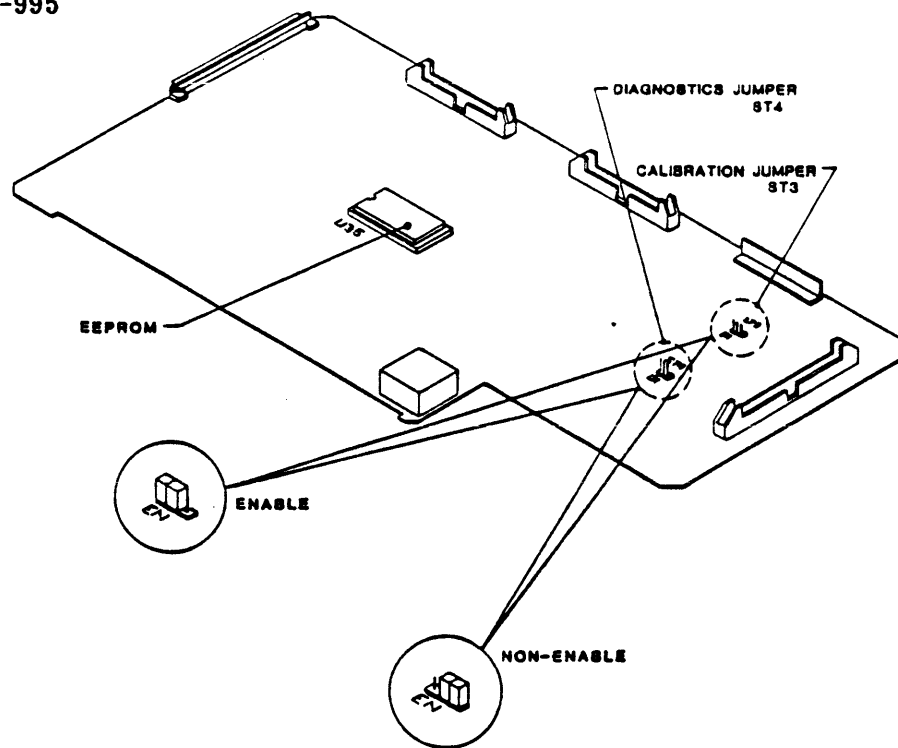

Figure 5-31. Drive Electronics Board, Calibration and Diagnostics Jumpers Location

5.4.2.9.1. DRIVE ELECTRONIC SET-UP

- A. Press DIAG. Display indicates: DIAG.
- B. Press ENTER. Display indicates: SELFTTEST (first Diagnostic parameter).
- C. Press SCAN three times. Display indicates: SET UP. Set-up Parameters are:
 1. UNIT NUMBER (Factory-set to 0) - (Don't care about Calibrate Jumper).
 - a. Repeatedly pressing SCAN displays each of eight Numbers: 0 through 7.
 - b. Pressing ENTER prepares the displayed Number for storage. The Readout indicates: LOAD?.
 - c. Pressing LOAD stores the displayed Number as the new Unit Number.
 2. DENSITY SELECTION (Factory set to NORMAL)
 - a. NORMAL: Allows selection and operation in local or remote density modes.
 - b. REM ONLY: Allows selection and operation in remote density modes.
 3. DEFAULT DENSITY (Factory set to 1600 REM) (Calibrate Jumper - Don't care).
 - a. Repeatedly pressing SCAN changes the Density Parameters and the corresponding Readout to each of the eight Density Configurations: 800, 800 REM, 1600, 1600 REM, 3200 and 3200 REM.
 - b. Pressing ENTER prepares the displayed Density for storage. The Readout indicates: LOAD?
 - c. Pressing LOAD stores the displayed Density as the new Default Density.

NOTE: The Default Density is effective only following Power Up, and will not affect the present Operating Density.

FOLLOWING ITEMS REQUIRE CALIBRATE JUMPER IN ENABLE POSITION.

4. **SPEED (Factory set to HOST SEL)** The 9600B/9650B Drive provides the following Speed options to match a variety of Hosts:
 - a. **HOST SEL:** Speed selection is made by Host.
 - b. **AUTO SPD:** Drive automatically overrides Host-selected speed and selects speed for optimum Throughput.
 - c. **50 IPS:** Drive performs at 50 ips regardless of Host selection.
 - d. **100 IPS:** Drive performs at 100 ips regardless of Host selection.
5. **TIME OUT (Factory set to 25FT ON):**
 - a. **25FT ON:** Drive stops motion and sets Hard Error Flag IHER if no data is detected within 25 feet after a Read or Read Space Command.
 - b. **25FT OFF:** Drive ignores no-data-detected information, if it occurs, and continues motion. (The use of a blank tape could cause a runaway.)
6. **SECURITY (Factory set to ENABLED):**
 - a. **ENABLE:** Drive can do a Security Erase on command.
 - b. **DISABLE:** Drive cannot do a Security Erase.
7. **PARITY (Factory set to IGNORE):**
 - a. **CHECK:** Drive will check the parity of Write Data from the Host.
 - b. **IGNORE:** Drive will ignore the parity of Write Data from the Host.
8. **LONG GAP (Factory set to 1.2 INCH):** Choices are: 0.45, 0.6, 1.2, 2.5
The length of the Long Gap will affect the Re-Instruct Window to maintain streaming when writing at 100 ips. By increasing the Gap, the Re-Instruct Window will also increase in length. This setting only has an effect on Write Commands at 100 ips with LGP active on the Host Interface.
9. **NRZI CCG (Factory set to ENABLED):**
 - a. **ENABLED:** In NRZI Mode, the CRC and LRC Characters will be sent to the Host following each Data Block.
 - b. **DISABLED:** In NRZI Mode, the CRC and LRC Characters will not be sent to the Host.
10. **CLR FBSY (Factory set to POSTREPO):** Effective in Streaming Mode. For Hosts that reinstruct with the removal of FBSY, this option should be set to WITH DBY.
 - a. **WITH DBY:** FBSY clears while tape is still at speed in Streaming Mode.
 - b. **POSTREPO:** FBSY clears after repositioning.
11. **IFEN (Factory set to NORMAL):** Hosts that do not support Formatter Enable (FEN), or that use FEN as a pulse (instead of a level) to activate the Formatter, should set this option to INVERT. Refer to Section I for a full definition of FEN.
 - a. **NORMAL:** Formatter Enable (FEN) is retained as received.
 - b. **INVERT:** Formatter Enable (FEN) is inverted.
12. **DENSITY OUTPUT (Factory set to CODED):** Determines how the density will be reported to the Host.
 - a. **CODED:** Density will be coded on DEN0 and DEN1.
 - b. **NRZ ONLY:** DEN0 will be true only for NRZI.

13. FMK GAP:

- a. EXTENDED: 3.5" gaps will be recorded before filemarks.
- b. NOMINAL: Standard interrecord gaps (PE, DDPE, NRZI = .6", will be recorded preceding filemarks.

5.4.2.9.2 CALIBRATION, ELECTRONIC**A. General:**

1. In Cal Mode, the Calibration Jumper must be installed in ENABLE Position to store the selected parameters. If the jumper is not installed, and a store operation is attempted, the Readout displays, "JUMPER?" and the RWND/UNL LED flashes. Pressing RWND/UNL aborts the calibration attempt.
2. In Cal Mode, pressing ENTER displays the Calibrate Functions: AUTO and MANUAL. Again pressing ENTER enables the currently displayed Function and displays the first related Parameter.
3. Once a Function has been enabled (by pressing ENTER), again repeatedly pressing SCAN displays the Parameters for that Function
4. Once a Parameter has been selected per Step 3 above, pressing ENTER starts the operation.

B. Preparation:

With the Calibration Jumper in ENABLE position, load a scratch tape by pressing LOAD.

C. Read Amp Gain Adjustment, General Information:

With CAL Function entered per Item A.2. above, repeatedly pressing SCAN alternately displays: AUTO and MANUAL. Then, again pressing ENTER enables the displayed function.

1. AUTO Selection. Repeatedly pressing SCAN in turn displays the densities: ALL, 800, 1600, and 3200. Pressing ENTER selects the displayed density or WRT CURR.
 - a. ALL. When ALL is selected, the Readout indicates: CONFIRM. Then, pressing ONLINE moves tape forward, and the Drive automatically calibrates for all densities at both 50 ips and 100 ips, and Write Current.
 - b. 800, 1600 and 3200.
 - 1) For any Density, pressing ENTER selects the displayed density and displays: 50 IPS.
 - 2) Repeatedly pressing SCAN alternately displays 100 IPS and 50 IPS. Again pressing ENTER selects the displayed speed, and the Readout indicates: CONFIRM?.
 - 3) Pressing ONLINE starts the calibration procedure. See Paragraph 5.4.2.9.2, Step B.
2. Manual Selection
 - a. Repeatedly pressing SCAN in turn displays the three densities: 800, 1600, and 3200.
 - b. (Same as Step 1.b above.)

D. Read Gain, Automatic Adjustment:

1. Repeatedly press SCAN until display indicates: CAL.
2. Press ENTER. Display indicates: AUTO (Auto Amplifier-Adjust).
3. Press ENTER again. Display indicates: ALL (all Densities and all Speeds for all Channels).
4. Press ENTER again. Display indicates: CONFIRM?.
5. Press ONLINE. Drive sequences through and adjusts Read Amplifier Gain at the four densities for 50 and 100 ips, and adjusts the Write Current. Front Panel Digital Display and the DENSITY LEDs operate to indicate each phase of automatic adjustment sequence.
6. After completing the sequence, tape motion stops, and the display indicates: AUTO, and the 1600 Density LED lights.

E. Read Gain, Manual Adjustment:

NOTE: Although Read Gain adjustments can be made manually, it is recommended that the Read Gain Manual feature be used only to verify the Automatic Read Gain adjustments.

1. Connect oscilloscope probe to TP401 on the Read Analog Board.
2. Turn AC power on.
3. Reconnect Calibrate Jumper to ENABLE position, install a reel of scratch tape, and load by pressing LOAD.
4. Press DIAG, then repeatedly press SCAN until display indicates: CAL.
5. Press ENTER. The display indicates: AUTO.
6. Press SCAN. The display indicates: MANUAL (Manual Gain Adjustment).
7. Press ENTER. The display will indicate: 800 (Density). If desired, press SCAN as often as necessary to select the desired Density.
8. Press ENTER again. The display will indicate: 50 IPS. If desired, press SCAN to select 100 IPS.
9. Press ENTER again. The display will indicate: CONFIRM?.
10. Setting Adjustment Parameters:
 - a. If you made a mistake when selecting the Density and Speed:
 - 1) Press DIAG to abort the adjustment. The display indicates: CAL.
 - 2) Repeat Steps 5 through 10.
 - b. If you have correctly selected Density and Speed, press ONLINE. This stores the selected Density and Speed as adjustment parameters. The display indicates: RANGE XX (XX = number from 0 to 15, representing the Course Gain of the system). The Front Panel pushbuttons will now perform the following functions:

<u>Pushbutton</u>	<u>Function</u>
SCAN	Selects the parameter and the Data Amplifier Channel to be calibrated. RANGE (Course Gain - all Channels), AMP-0 through AMP-7 and AMP-P.
ENTER	Increments gain (high value = low gain)
START/STOP	Decrements gain. (low value = high gain)
DIAG	Stops the present operation.
LOAD	Enters (stores) Read gain values.

11. Repeatedly press SCAN until display indicates AMP-P XX.
12. Repeatedly press ENTER or START/STOP until display indicates AMP-P 8.
13. Repeatedly press SCAN until display indicates RANGE XX.
14. Repeatedly press ENTER or START/STOP until voltage amplitude at TP401 is nominally 3.5 volts p-p (for 800 CPI) or nominally 4.0 volts p-p (for all other densities). The RANGE has now been set to center voltage.
15. Press SCAN. The display indicates: AMP-5 XX (XX = number from 0 to 15, representing Gain of Channel 5).
16. Repeatedly press ENTER or START/STOP until the amplitude at the Test Point is 3.5 +/- 0.4V p-p (for 800 CPI) or 4.0 +/- 0.4V p-p (for all other densities).
17. In turn, connect the oscilloscope probe to the Test Point in each successive Read Channel of the Read Analog Board, press SCAN to display the corresponding Channel, and repeat Step 19. The following table shows Track, Test-Point and Channel relationships.

<u>Track</u>	<u>Test Point</u>	<u>Channel</u>	<u>Track</u>	<u>Test Point</u>	<u>Channel</u>
1	101	5	6	601	1
2	201	7	7	701	0
3	301	3	8	801	6
4	401	P	9	901	4
5	501	2			

18. Press RWND/UNL. This stops the operation, and the display indicates: LOAD?.
19. Press LOAD. This stores the new adjustment values.

F. Read Skew Adjustment:

1. Load a Skew Tape into the Drive. Select 800 CPI.
2. Connect a dual-trace oscilloscope to the Read Analog Board, one probe to TP101, the other to TP901. Trigger on TP901.
3. In Diagnostic Motion Mode, run the tape forward at 50 ips.
4. Using a small flat-blade screwdriver and, with the tape in motion, and while observing the waveforms on the Oscilloscope, turn the adjustment screw on the Magnetic Head counterclockwise until there is no apparent waveform motion. Then, turn the screw slowly clockwise until the two waveforms move into phase as illustrated on the following page; continue to turn the screw clockwise until the two waveforms come in phase a second time.

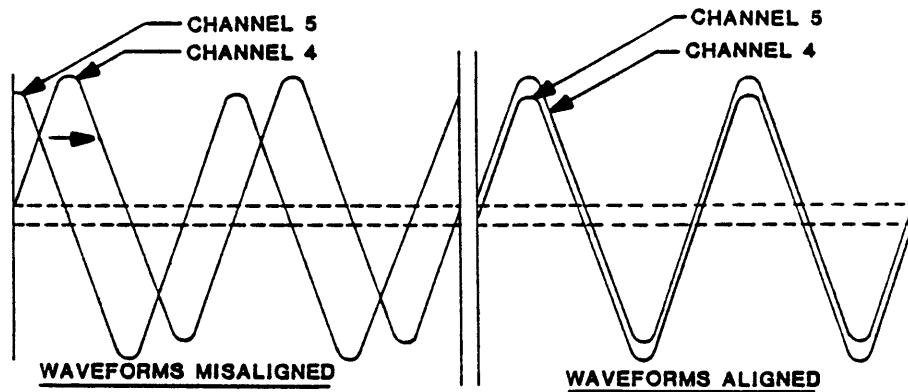

- Moving one probe to TP401 (Channel P), and triggering on TP401, in turn, connect the other probe to each Read Channel and record the waveform displacement in microseconds. Prepare a chart similar to:

<u>TP</u>	<u>Channel</u>	<u>Scatter Value</u>	<u>TP</u>	<u>Channel</u>	<u>Scatter Value</u>	<u>Max Scatter</u>
701	0	_____ us	901	4	_____ us	_____ us
601	1	_____ us	101	5	_____ us	
501	2	_____ us	801	6	_____ us	
301	3	_____ us	201	7	_____ us	

- Subtract the largest positive value from the largest negative value. The difference constitutes the maximum scatter, which should not exceed 3.4 us. If maximum scatter is out of specification, repeat Steps 4 and 5.
- Run the tape in Read Reverse, and repeat Steps 5 and 6. The maximum scatter should be within specification per the chart above. If maximum scatter is out of specification, repeat Steps 5, 6, and 7. If scatter is out of tolerance replace Head.
- Press DIAG to exit from Motion Mode. Unload and remove the Skew Tape.

G. Tracking:

Special Items Required: Set of Shims P/N 98-00215-001. These are of the following thicknesses: .001/.003/.005/ inch.

- Load a write protected tracking tape (P/N 13-00106-001). Initialize the read circuits and move the tape forward using the 50 IPS READ in 800 cpi density in the DATADIAG diagnostic. With the oscilloscope, monitor tract 5 of the Read Analog Board at TP501.
- Refer to Figure 5-32 and measure the amplitude difference between the two positive peaks, +P1 and +P2. With the head properly positioned vertically on the tape, the amplitude of the least positive peak (+P1 or +P2) will be within 80% of the amplitude of the most positive peak (+P1 or +P2). 80% corresponds to 0.002" tracking error.

If P1 is greater than P2 in the forward direction, remove shim(s). If P1 is less than P2 in the Forward direction, add shim(s).

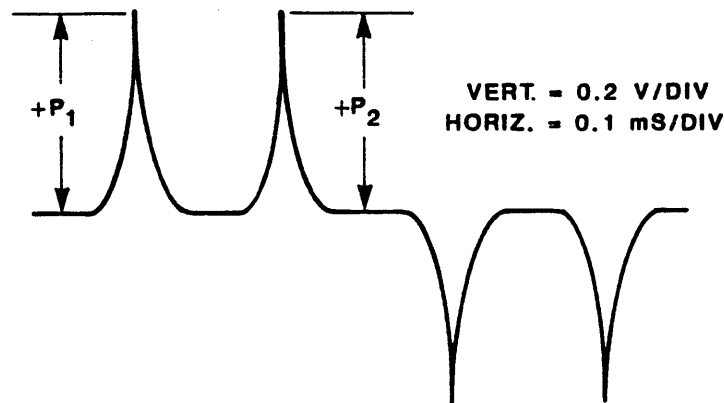

Figure 5-32.

3. Read Reverse at 50 ips, and verify reverse tracking is within the specifications in Step 2 above.
4. Allow the tracking tape to return to BOT at 50 ips. DO NOT REWIND the tape, as subtle tape damage, stretching, or excessive wear may occur which will reduce the accuracy, effectiveness and/or the life span of the standard.
 - a. Exit the diagnostics and unload and remove tracking tape.

5.5 DIAGNOSTICS

5.5.1 GENERAL

- A. In Diagnostic Mode, repeatedly pressing SCAN displays the Diagnostic Functions: SELFTEST, MOTION, DRV ADJ, SET-UP, CALIBRATE, and DATA DIAGNOSTICS. Pressing ENTER enables the function displayed.
- B. Having selected a diagnostic function per Step A, again repeatedly pressing SCAN displays the functional categories or parameters of the selected function.

5.5.2 MOTION DIAGNOSTICS

In Motion Mode, the operator can check and adjust the tape path, and Check Motors and Servos:

- A. After selecting Diagnostic Motion Mode per paragraph 5.5.1 Step A, repeatedly pressing SCAN displays the Motion Parameters listed in Paragraph 5.4.2.7.
- B. After selecting a Motion Parameter (Step A), pressing ENTER enables the Parameter.
- C. With the Motion Parameters enabled, pressing START/STOP starts the motion enabled. Again pressing START/STOP stops motion.
- D. When tape is in motion, the DIAG LED flashes at 0.5 Hz.

5.5.3 DRIVE ADJUST (DRV ADJ)

- A. **Buffer Arms:** The 9600B/9650B Drive automatically adjusts the gain of the Buffer Arms Sensors on Power Up. In Buffer Arms Mode, the Operator can check the gain of the Buffer Arms Sensors as indicated on the Digital display.
- B. **Hub Sensor:** In Hub Sensor Mode, the operator can manually rotate the Hub to check the status of the Reel-In-Place Sensor as indicated on the display, and adjust as necessary.
- C. **Reel Servo:** In Reel Servo Mode, the operator can check the operation of the Reel Servo System and make adjustment as necessary.
 - 1. **Checking the Reel Servo System.** See Diagnostics, Section IV, par 4.5.2.4.
 - 2. **Capstan Motor Calibration.** The Capstan must be calibrated with the Case of the Capstan Motor at a temperature of 25 to 28°C. This can be accomplished by setting the room (ambient) temperature between 25 and 28°C and running the Drive without tape movement (Fan cools Drive).
 - a. Access RL SERVO per Chart C in Section 4.5.2.4. The display should indicate: G = X.XX .
 - b. Operate Drive without tape movement for 40 minutes to lower the Capstan Case Temperature to within 25 to 28°C.
 - c. Press ENTER. Drive performs a Servo Test, changing the value of G.
 - d. Raise the Deck Assembly to Maintenance Position per 5.2.2.
 - e. Move Calibration Jumper (Ref Figure 5-31) to ENABLE Position.
 - f. Press LOAD. The Drive stores the new Gain Value.
 - g. Replace the Calibration Jumper to Non-Enable Position.
 - h. Lower the Deck Assembly per 5.2.2.

SECTION VI
PARTS IDENTIFICATION

SECTION VI

PARTS IDENTIFICATION

6.0 INTRODUCTION

This Section contains parts ordering information and lists replacement and recommended spare parts. Figures 6-1 thru 6-5 include parts lists that identify each part illustrated. Parts Tables 6-1 and 6-2 list parts recommended as spares. Table 6-3 lists recommended Maintenance Tools.

Field-Repair and -Change Kits consist of parts assembled and adjusted at the factory. Repair Kits are for repair of Kennedy products. Change Kits are for adding standard or special options not originally included in the equipment. Kits include installation instructions.

6.1 PARTS WARRANTY

Parts are warranted to be free from defects in materials and workmanship for 90 days from the date shipped from Kennedy. This warranty does not apply to Kennedy parts that have been neglected, misused, improperly installed, poorly maintained, or damaged by accident. Liability under this Warranty is limited to replacement or repair of defective parts. The equipment user must obtain Return Authorization (RA) from Kennedy Company before shipping the defective parts. The customer must send the package postage paid.

6.2 OUT-OF WARRANTY EMERGENCY PARTS

Kennedy Company expedites shipment of emergency orders for out-of-warranty parts. The price of expedited orders includes the standard price for the part plus a \$75.00 Expediting Fee. Kennedy ships emergency orders within one week of receipt of the order.

6.3 PARTS ORDERING INFORMATION

Spare Parts orders and inquiries should be directed to:

SHUGART CORPORATION 9292 Jeronimo Road Irvine, Ca 92718	Tel: (714) 770-1100 Fax: (714) 859-4960
--	--

Include the following information in all orders:

- a. Serial Number and Part Number of the equipment (printed on the Serial Number Tag located on the rear panel of the unit).
- b. Company Name, shipping and billing address.
- c. Purchase Order Number.
- d. Authorized person's name and phone number.
- e. Preferred method of shipment (FOB Irvine, California).
- f. Name, Part Number, and quantity (Ref par. 6.3.3.d) of parts being ordered.
- g. Return Authorization Number.
- h. For items returned for repair or replacement, include description of malfunction.

6.3.1 MINIMUM PARTS ORDERS

The minimum domestic order value is \$50.00. Minimum international order value is \$100.00. Refer to Parts Price List Manual for parts prices. For Emergency Orders, order value does not include the \$75.00 Expedite Fee (See paragraph 6.2).

6.3.2 RETURNING PARTS TO KENNEDY

If a part must be returned for repair or replacement, the customer must first notify the nearest Customer Service Office listed in Paragraph 6.3.4 to obtain a Return Authorization Number (RA Number). If the part is available at that Office, the Kennedy Agent will issue the RA Number and give further instruction for returning the part. If the part is not available at that local office, the customer must notify the Kennedy Main Office at Irvine, California to obtain the RA Number. The part must be returned to the Office that issued the RA Number. Orders will be accepted via Telephone or Telex, but will not be shipped until a confirming Purchase Order is received from the customer.

NOTE 1: Parts sent to Kennedy Company that do not include a Return Authorization Number will be returned to the sender COD unopened. The RA Number must be written on the outside of the package in a conspicuous place.

NOTE 2: Send only the item(s) needing repair or replacement. Use standard good packaging procedures. Kennedy Company will not be responsible for any accessories to the repair item. **DO NOT SEND ACCESSORIES.**

6.3.3 PARTS ORDER LEADTIME

- a. Delivery of spare parts: 60-90 days After Receiving Order (ARO).
- b. Delivery of tools and special parts: 90 days ARO
- c. Delivery of parts for obsolete equipment: 120 days ARO
- d. For quantities of six or more of one item or for items not covered by these guidelines, consult your nearest Kennedy Company Customer Service Department (Ref par. 6.3.4).

6.3.4 KENNEDY COMPANY CUSTOMER SERVICE ADDRESSES

For service and general information, contact the nearest Kennedy Company Customer Service Office listed below:

United States:

Kennedy Company
Main Office
9292 Jeronimo Road
Irvine, CA 92718
Tel: (714) 770-1100
Fax: (714) 859-4960

Kennedy Company
Eastern District
210 West Cummings Pk.
Woburn, MA 01801
Tel: (617) 935-9787
Fax: (617) 932-3351

Kennedy Company
Eastern District
4364 L.B. McLeod
Orlando, FL 32811
Tel: (305) 843-9335

United Kingdom

Kennedy International Inc.
Ashville Way
Wokingham, Berkshire
RG11 2PL England,
Tel: 44/734 77.60.33
Fax: 44/734 77.60.23
Telex: 847871 KENUKS G

Central Europe

Kennedy France
8 Sq. Leon Blum
92800 Puttux
France
Tel: 33-1-47-78-86-34
Fax: 33-1-47-78-96-11

Shugart GmbH
Drygalski - Allee 33
D-8000 Muenchen 71
West Germany
Tel: 49/89 780 080
Fax: 49/89 780 0828
Telex: 524752

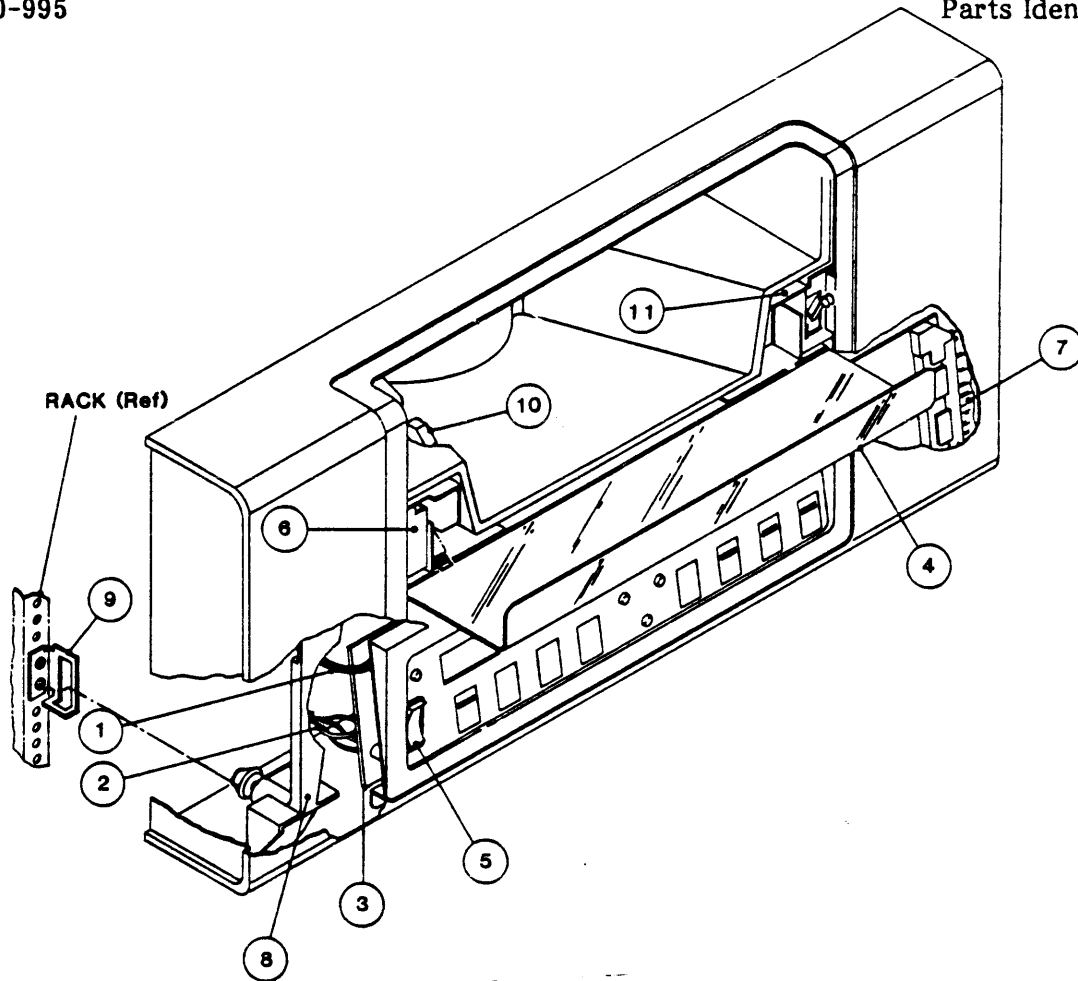

Parts List: Front Panel Assembly P/N 90-09191-XXX

Item	Part Number	Description
1	90-07587-003	Wire Assembly
2	90-09159-002	Power Switch Cable Assembly
3	90-07947-312	Operator Control Panel PCBA
4	91-09051-001	Tape Access Door
5	51-00099-001	Switch, Power
6	22-00008-002	Door Lock Solenoid, 24 VDC
7	90-09304-003	Front Panel Shielded Cable Assembly
8	91-08082-001	Latch
9	91-08084-001	Bracket Catch
10	(Reference)	Manual Reel Locking Lever
11	51-00196-001	Microswitch

Figure 6-1. Front Panel Assembly

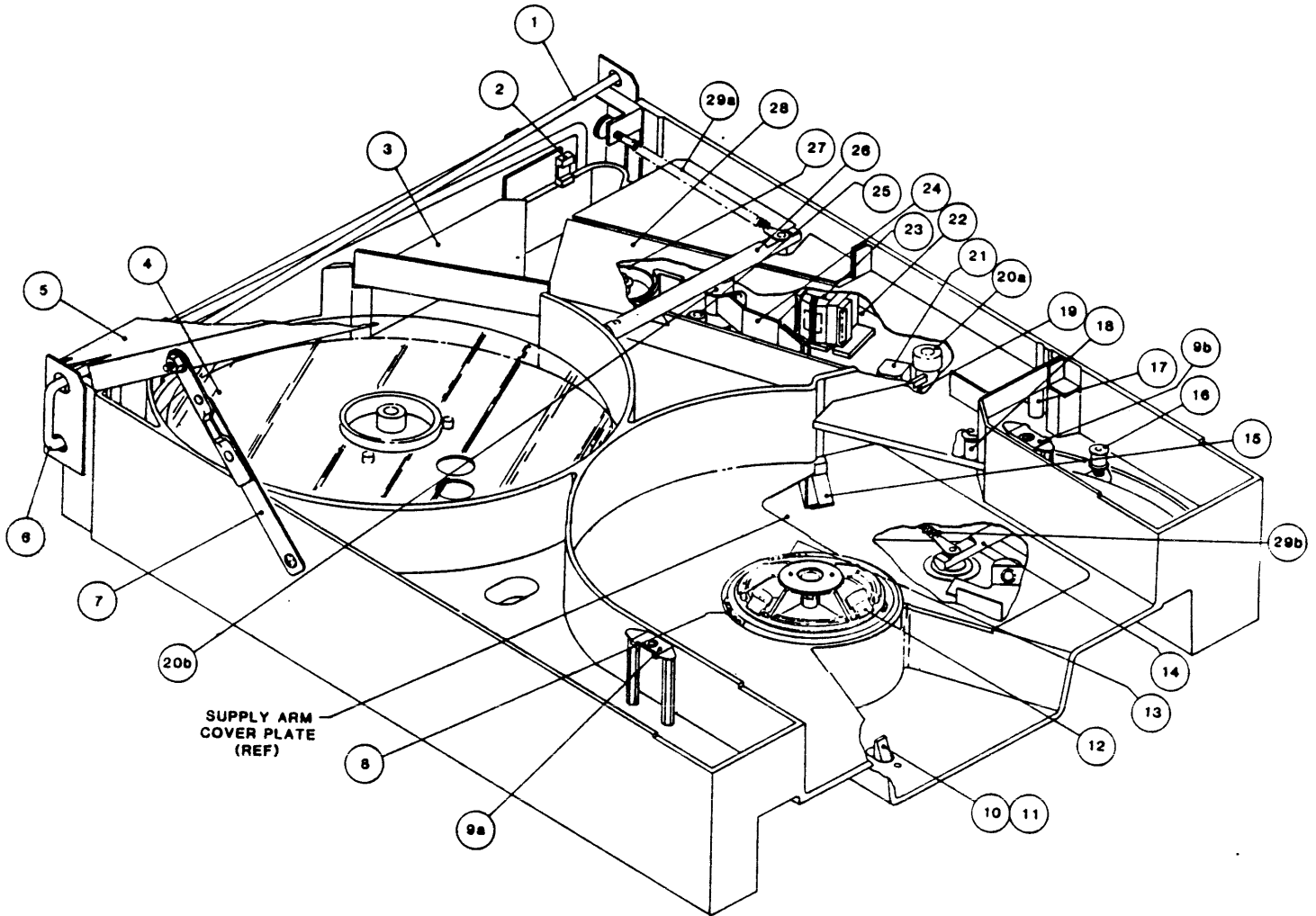
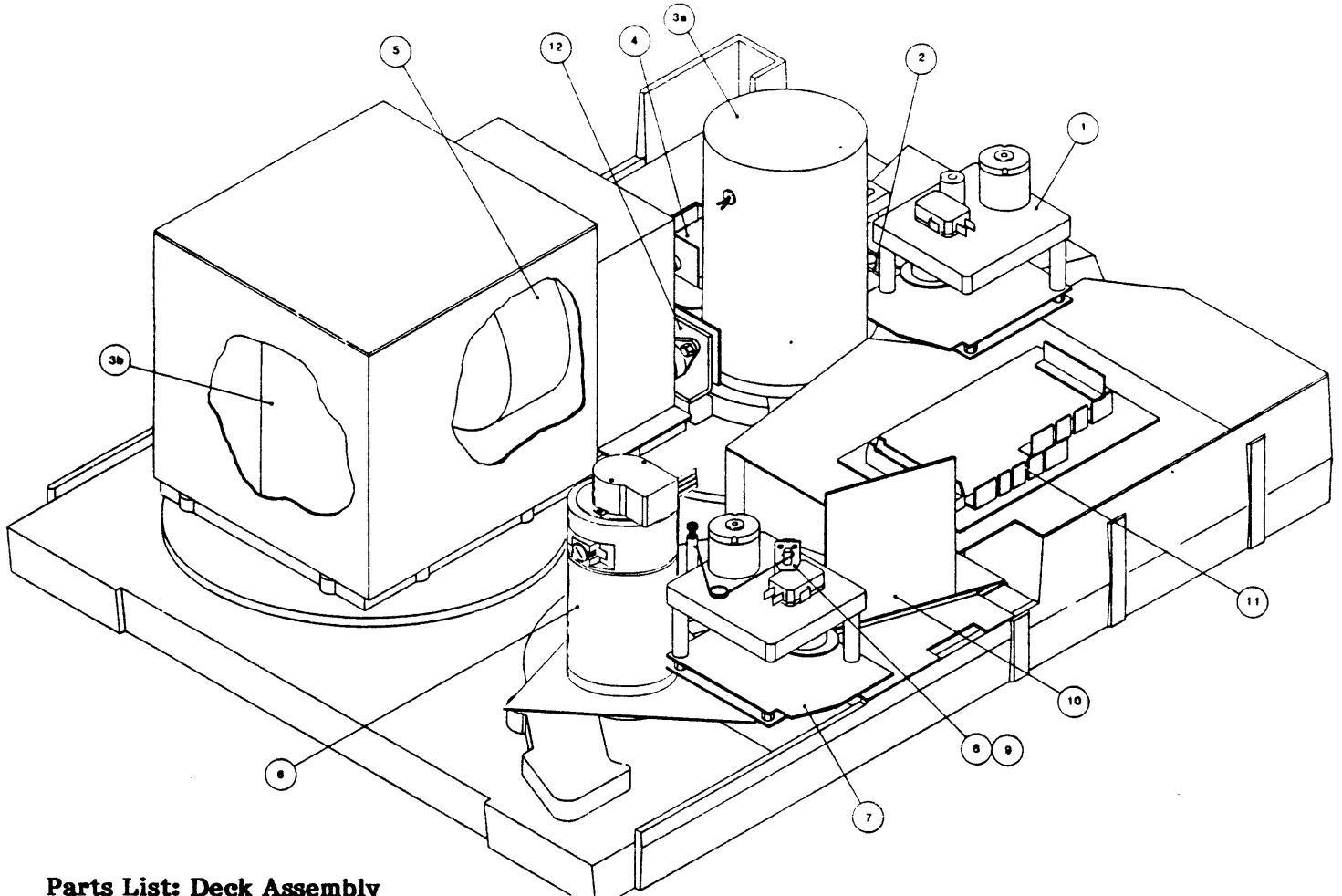

Figure 6-2. Deck Assembly, Top View (Sheet 1 of 2)

Parts List: Deck Assembly

Item	Part Number	Description
1	91-07731-401	Torsion Bar, Right
2	37-00053-101	Take-up Arm Limit Sensor
3	91-09110-001	Cover, Tape Path
4	90-09014-003	Take-up Hub Assembly
5	91-07291-005	Cover, Deck
6	91-07731-301	Torsion Bar, Left
7	90-08028-001	Brace Assembly
8	90-07119-102	Reel-In-Place Sensor Assembly (hidden)
9 (a,b)	28-00259-001	Fastener, 1/4-Turn, Rec., Clip-On
10	91-09037-001	Knob
11	91-09036-001	Release Lever
	91-09195-001	Release Lever (Low Profile Hub)
12	90-09021-004	Supply Hub Assembly
	90-09395-001	Supply Hub Assembly (Low Profile Hub Assy.)
13	90-07144-002	File Protect Sensor Assembly (hidden)
14	90-09042-107	Supply Arm Assy. (Bottom)
15	37-00053-001	Supply Arm Limit Sensor
16	91-09041-002	Tension (Buffer) Arm Roller
17	90-07334-001	Tape-In-Channel Sensor Assembly
18	91-07211-002	Fixed Roller
19	90-07334-002	Tape-In-Channel Emitter Assembly
20 (a,b)	90-09154-001	Split Tape Guide
21	90-05906-103	BOT/EOT Sensor Assembly
22	90-09002-001	Head/Guide-Plate Assembly
23	90-07524-101	Magnetic Head Assembly
24	90-09171-001	Shield Assembly
25	91-09167-002	Post
26	90-09042-207	Take-up Arm Assembly (Top)
27	91-05699-002	Capstan Wheel
28	91-09128-001	Tape Path Cover Assembly
29 (a,b)	91-09115-002	Spring, Tension Arm

Figure 6-2. Deck Assembly, Top View (Sheet 2 of 2)



Parts List: Deck Assembly

Item	Part Number	Description
1	90-09048-101	Retract & Pivot Sensor Assembly (Supply)
2	90-09031-001	Actuator Arm Assembly
	90-08282-002	Actuator Arm Assembly (Low Profile Hub)
3 (a,b)	90-09020-001	Reel Motor Assembly
4	22-00095-002	Hub Lock Solenoid
5	90-07483-001	Vacuum Motor Assembly
6	90-07333-101	Capstan Motor Assembly
7	90-09048-201	Retract & Pivot Sensor Assembly (Take-up)
8	91-08180-001	Retract Cam Plate
9	91-08179-001	Linkage, Shield
10	90-06923-001	Read Preamplifier PCBA
11	90-07228-301	Interconnect PCBA
12	90-07295-002	+/-12 VDC Regulator Assembly

Figure 6-3. Deck Assembly, Bottom View

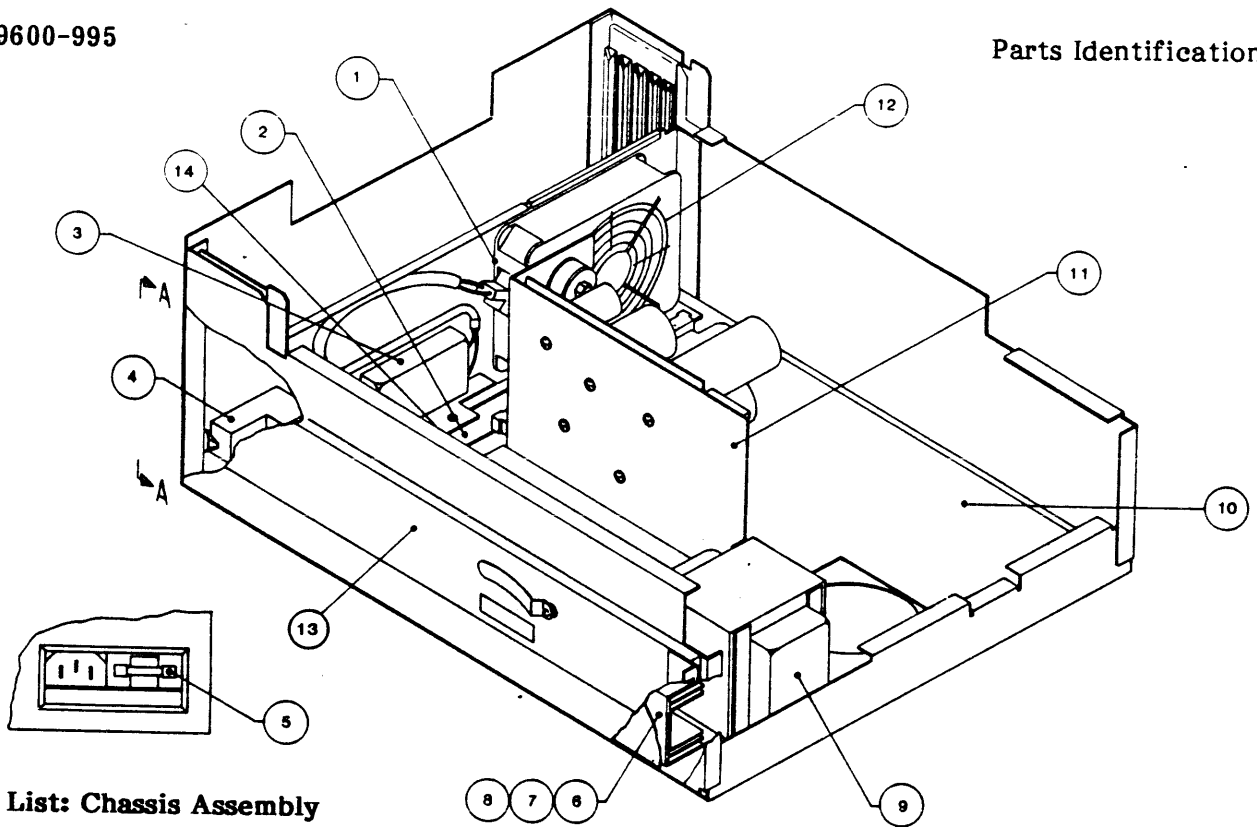

Parts List: Chassis Assembly

Item	Part Number	Description
1	26-00027-003	Fan, 115 VAC
	* 26-00040-001	Fan, 24 VDC
2	90-07108-002	Mother Board PCBA
3	27-00012-001	Filter, EMI
	* 27-00009-001	Filter, EMI, 10A
4	90-09155-001	Power-In Assembly
	* 21-00319-001	Power-In Connector
5	51-00132-005	Fuse, 3A (for 220V Operation)
	51-00133-060	Fuse, 6A (for 115V Operation)
	* 51-00132-100	Fuse, 10A (for DC Operation)
6	90-07516-006	Servo Amplifier Assembly
7	90-07111-015	Servo Power Amplifier PCBA (Part of Item 6)
8	90-07147-004	Servo Preamplifier PCBA (Part of Item 6)
9	90-07318-003	Transformer Assembly
	* 90-08153-002	DC/DC Converter, 48 VDC
	* 90-08153-502	DC/DC Converter, 60 VDC
10	90-08952-XXX	Drive Electronics PCBA
11	90-07296-302	Power Supply Assembly
	* 90-08196-102	Power Supply Assembly
12	26-00027-501	Finger Guard
13	28-00352-001	Chassis Slide 22" (pair)
	28-00352-101	Slide Extender 8" (pair)
14	* 90-08172-002	Relay PCB, 48 VDC
	* 90-08172-502	Relay PCB, 60 VDC

*DC Units

Figure 6-4. Chassis Assembly

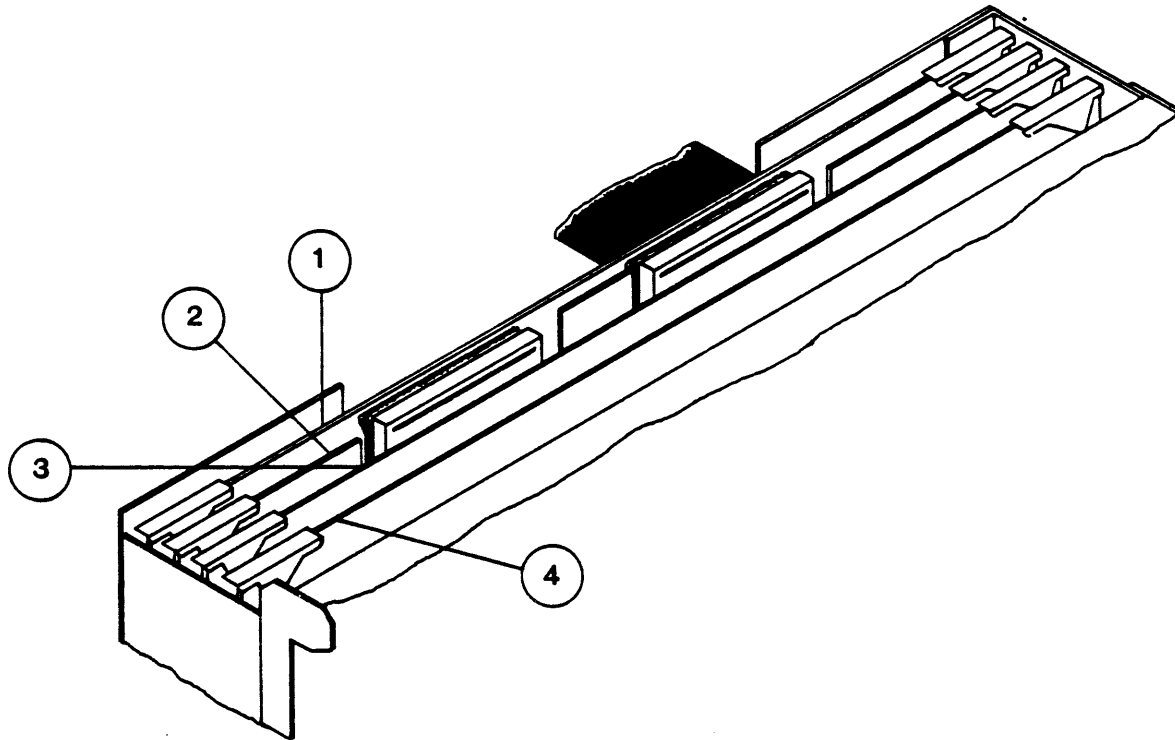

Parts List: Card Cage PCBAs

Item	Part Number	Description
1	90-08951-XXX	Formatter PCBA
2	90-09017-XXX	Read Analog PCBA
3	90-09060-XXX	Read/Write Digital PCBA

Figure 6-5. Card Cage Printed Circuit Boards

**TABLE 6-1. RECOMMENDED SPARE PARTS
(Field Support)**

Fig	Item	Part Number	Description	Recommended Quantity*
2	21	90-05906-103	EOT/BOT Sensor Assembly	
3	12	90-07295-002	+/-12 VDC Regulator Assembly	
4	5	51-00132-005	Fuse, Slo Blo, 3A 250V, Cer	
4	5	51-00133-060	Fuse, Norm Blo, 6A 250V, AGC3	
		** 51-00132-100	Fuse, 10A (for DC Operation)	
4	7	90-07111-015	Servo Power Amplifier PCBA	
4	8	90-07147-004	Servo Preamp PCBA	
4	9	** 90-08153-002	DC/DC Converter, 48 VDC	
		** 90-08153-502	DC/DC Converter, 60 VDC	
4	10	90-08952-XXX	Drive Electronics PCBA	
4	11	90-07296-302	+5 VDC Regulated Power Supply	
		** 90-08196-102	+5 VDC Regulated Power Supply	
5	1	90-08951-XXX	Formatter PCBA	
5	2	90-09017-XXX	Read Analog PCBA	
5	3	90-09060-XXX	Read/Write Digital PCBA	
<p>NOTE: * Unless otherwise specified, Recommended Quantity is 1. **DC Unit</p>				

**TABLE 6-2. RECOMMENDED SPARE PARTS
(Depot Support)**

Fig	Item	Part Number	Description	Recommended Quantity*
All Items listed in Table 6-1.				
1	3	90-07947-312	Operator Control Panel PCBA	
1	6	22-00008-002	Door Lock Solenoid, 24 VDC	
2	2	37-00053-101	Take-up Arm Limit Sensor	
2	8	90-07119-102	Reel-in-Place Sensor Assembly	
2	12	90-09021-004	Supply Hub Assembly	
		90-09091-001	Tab Assembly (Reel in Place, and File Protect) (Part of Item 2-12)	
2	13	90-07144-001	File Protect Sensor Assembly	
2	14	90-09042-107	Supply-Arm Assembly	
2	15	37-00053-001	Supply Arm Limit Sensor	
2	17	90-07334-002	Tape-in-Channel Emitter Assembly	
2	18	91-07211-002	Fixed Roller	2
2	19	90-07334-001	Tape-in-Channel Sensor Assembly	
2	20	90-09154-001	Split Tape Guide	2
2	21	90-05906-103	EOT/BOT Sensor Assembly	
2	23	90-07524-101	Magnetic Head Assembly	

TABLE 6-2. RECOMMENDED SPARE PARTS (CONTINUED)
(Depot Support)

Fig	Item	Part Number	Description	Recommended Quantity*
2	26	90-09042-207	Take-up Arm Assembly (Top)	
2	27	91-05699-002	Capstan Wheel (Part of Item 3-6)	
2	29	91-09115-002	Spring, Tension Arm	2
3	1	98-09048-101	Retract & Pivot Sensor Assy. (Supply)	1
3	3	90-09020-001	Reel Motor Assembly	2
3	4	22-00095-002	Hub Lock Solenoid	
3	5	90-07483-001	Vacuum Motor Assembly	
3	6	90-07333-101	Capstan Motor Assembly	
3	7	98-09048-201	Retract & Pivot Sensor Assy. (Take-up)	1
3	10	90-06923-001	Read Preamplifier Assembly	
3	11	90-07228-301	Interconnect PCBA	
4	1	26-00027-003	Fan, 115 VAC	
	**	26-00040-001	Fan, 24 VDC	
4	2	90-07108-002	Mother Board PCBA	
4	3	27-00012-001	Filter, EMI, 6A	
	**	27-00009-001	Filter, EMI, 10A	
		98-00208-001	Arm Height Adjustment Shim Kit	2
		98-00209-001	Fixed Roller Height Adjust. Shim Kit	2
		98-00215-001	Head Height Adjustment Shim Kit	

NOTE: *Unless otherwise specified, Recommended Quantity is 1.
**DC Unit

TABLE 6-3. RECOMMENDED MAINTENANCE TOOLS

PART NUMBER	DESCRIPTION
54-00036-001	Skewmaster Tape
54-00103-001	Alignment Tool, Tape Guides
54-00171-001	Buffer Arms Height Adjustment Tool Kit
54-00100-001	Capstan Puller
54-00173-001	Collet Height Adjustment Tool
54-00174-001	Arm Position Tool Kit
90-02324-001	Maintenance Kit
	Head Cleaner
	Hex Socket Keys - 6/16, 5/32, 1/8, 3/32
	Reflective Marker Strips
	Magnesium Visualizing Solution
	Lint-Free Swabs
	Loctite, Grade H
90-07117-001	Card Extender
(Common)	Set of Nut Drivers or Open-End Wrenches
(Common)	Phillips and Standard Screwdrivers
54-00126-001	Plastic Feeler Gauge Set (.012-.026)
13-00106-001	Tracking Tape

SECTION VII
WIRING/SCHEMATICS

SECTION VII
WIRING AND SCHEMATIC DIAGRAMS

7.0 GENERAL

This section contains wiring and schematic diagrams for the Model 9600B/9650B Tape Drive. Unless otherwise specified, electronic symbols conform to ANSI Y32.2, abbreviation to MIL-STD-12, and logic symbols to ANSI Y32.14 (MIL-STD-806C).

7.1 COMPONENTS

Unless otherwise specified:

- A. Resistor values are in ohms, +/-5%, 1/4-watt.
- B. Capacitor values are in microfarads.

7.2 LOGIC CONVENTIONS AND SYMBOLOGY**7.2.1 TTL LOGIC**

The 9600B/9650B Drive uses standard +5V TTL logic with the following state definitions and Logic Levels:

A. Logic States:

Logic ONE = high
Logic ZERO = low

B. TTL Medium Speed IC Logic Levels:**Input:**

ONE = +2.0V to +5.5V (Abs Max)
Indeterminate = +0.8 to +2.0V
ZERO = +0.8V to -0.5V (Abs Min)

Output:

ONE = +2.4V to +5.25V (Abs Max)
Indeterminate = +0.4 to +2.4V
ZERO = +0.4V to 0.0V (Abs Min)

C. TTL Medium Speed Low Power Consumption IC Logic Levels:**Input:**

ONE = +2.0V to +7.0V (Abs Max)
Indeterminate = +0.8 to +2.0V
ZERO = +0.8V to -0.3V (Abs Min)

Output:

ONE = +2.7V to +5.25V (Abs Max)
Indeterminate = +0.4 to +2.7V
ZERO = +0.4V to 0.0V (Abs Min)

D. TTL Super High Speed IC Logic Levels:**Input:**

ONE = +2.0V to +5.5V (Abs Max)
Indeterminate = +0.8 to +2.0V
ZERO = +0.8V to -0.3V (Abs Min)

Output:

ONE = +2.7V to +5.25V (Abs Max)
Indeterminate = +0.5 to +2.7V
ZERO = +0.5V to 0.0V (Abs Min)

7.2.2 LOGIC SYMBOLOGY

The following illustrations represent standard TTL logic symbols used in the 9600B/9650B Drive schematic diagrams.



7.3 SCHEMATIC FLOW

Schematic diagram are generally organized to show signal and/or function flow from left to right and from top to bottom. Exceptions to this rule may occur only in details where circuit simplicity is preferable.

7.4 TERMINALS

For a double-sided socket, terminals are designated with numbers for component-side connections and letters for circuit-side connections. These correspond to the actual socket designations. For a single-sided socket, all connections are designated by letters of the 22-character alphabet: ABCDEFHJKLMNPRSTUVWXYZ, or standard arabic numbers.

7.5 LIST OF SCHEMATICS (Item Numbers included for reference)

<u>Title</u>	<u>Number</u>	<u>Item</u>
9600B Interconnect (AC units)	8178-000	1
+5 Volt Power Supply (AC units)	7109-000	2
12V Regulator	7148-000	3
Interconnect Board	7228-000	4
Position Sensor	9069-000	5
Operator Control Panel	7947-000	6
Servo Power Amplifier	7111-000	7
Servo Preamp	7147-000	8
Motherboard	7108-000	9
Drive Electronics	8952-001	10
Formatter	8951-000	11
R/W Digital	9060-000	12
Read Preamplifier	6923-000	13
Read Analog	9017-000	14
Interconnect (DC units)	8207-600	15
9620 Power Supply Interconnect (DC units)	8222-000	16
Relay Board (DC units)	8172-000	17
+5 Volt Power Supply (DC units)	9378-500	18
Filter (DC units)	8229-000	19
Transformer (DC units)	8173-000	20
DC Converter (DC units)	8174-000	21

7.6 SYSTEM SIGNAL DISTRIBUTION

The following Chart shows signal flow among the circuit boards of the System. The Chart is organized in a "From-To" manner; that is: each listed signal is shown as flowing from one circuit board to another, referencing a schematic sheet and connector. The Circuit Board is identified by an acronym as defined in the Chart.

SYSTEM SIGNAL DISTRIBUTION CHART

FROM HOST

<u>Signal</u>	<u>To FMTR Sheet-Conn</u>	<u>LIST OF CIRCUIT-BOARD ACRONYMNS</u>	
ILWD	2-J1		
IERASE	4-J1	DIG R/W (9060)	Digital Read/Write
IEDIT		ELEC (8952)	Drive Electronics
IWFM		FMTR (8951)	Formatter
IWRT		INTCON (7228)	Interconnect Board
IREV		OCP (7947)	Operator Control Panel
ILOL		POSENS (9069)	Position Sensor
ILGAP		READA (9017)	Read Analog
IGO		READPRE (6923)	Read Preamplifier
IREW	4-J1	SERVPA (7111)	Servo Power Amplifier
IOFL	4-J2	SERVPRE (7147)	Servo Preamplifier
IFEN	4-J2		
IHSP	4-J2		
ITADO	5-J1		
IFAD	5-J2		
ITAD1	5-J2		
IW(0-7, P)	6-J1		

FROM FORMATTER (FMTR)

<u>Signal</u>	<u>From FMTR Sheet-Conn</u>	<u>To:</u>	<u>Schematic Sheet-Conn</u>
IR(0,1,4-7,P)	7-J2	Host	
IR(2,3)	7-J1		
IRSTB	9-J2		
IWSTB	9-J2	Host	
WD(0-7)	6-P1	DIG R/W	5-P1
LST WORD	8-P1	DIG R/W	5-P1
FDB(0-7)	10-P1	ELEC	3-P1
"		READA	
"		DIG R/W	
FSEL(0,1)		ELEC	
FSEL(0-6)		DIG R/W	3-P1
FSEL(2-6)	10-P1	READA	2-P1
FMTR STRB	11-P1	ELEC	3-P1
"		DIG R/W	3-P1
"		READA	2-P1
FMTR BUSY		ELEC	3-P1
FMTR ACKN	11-P1	ELEC	3-P1
ERASE PWR EN	13-P1	DIG R/W	14-P1
WRT PWR EN	13-P1	DIG R/W	14-P1
IFPT	5-J2	Host	
IRWD			
IRDY			
IONL	5-J2	Host	

FROM FORMATTER (FMTR) Continued)

<u>Signal</u>	<u>From FMTR Sheet-Conn</u>	<u>To:</u>	<u>Schematic Sheet-Conn</u>
IEEOT	5-J1	Host	
IRSC	5-J1		
ILDPA	5-J2		
IEOT			
INRZ			
ISPD			
IDENT	5-J2		
IFBY	5-J1		
IDBY	5-J2		
IHER			
ICER			
IFMK	5-J2	Host	

TO FORMATTER

<u>Signal</u>	<u>From Sheet-Conn</u>	<u>On PCBA</u>	<u>To FMTR Sheet-Conn</u>
FBREQ			10-P1
MSTR RES	3-P1	ELEC	2-P1
RD(0-7,P)	13-P2	DIG R/W	7-P2
RD DATA STRB	12-P2		9-P2
WRT DATA STRB	2-P1		9-P2
HRD ERROR	12-P1		10-P1
CRECTD ERROR	10-P1		10-P1
FILE MARK	10-P1	DIG R/W	10-P1
DDB(0-7)	3-P1	ELEC	11-P1
DRV SEL(0,1)	3-P1		
TACH	4-P1		
FWD/REV	4-P1		
DRV STRB	3-P1	ELEC	11-P1
RD BUSY		DIG R/W	13-P1
WRT BUSY		DIG R/W	
DRV BUSY		ELEC	
DRV ACKN	3-P1	ELEC	13-P1

FROM DRIVE ELECTRONICS (ELEC)

<u>Signal</u>	<u>From ELEC Sheet-Conn</u>	<u>To PCBA</u>	<u>Schematic Sheet-Conn</u>
DDB(0-7)	3-P1	FMTR	11-P1
DRV STRB	3-P1	FMTR	11-P1
DRV SEL(0,1)	3-P1	FMTR	11-P1
MSTR RES	3-P1	FMTR	2-P1
"	"	DIG R/W	3-P1
FWD/REV	4-P1	FMTR	11-P1
TACH	4-P1	FMTR	11-P1
DRV BUSY	3-P1	FMTR	13-P1
DRV ACKN	3-P1	FMTR	13-P1
NRZ LED	4-J6	OCP	2-J1
WEN LED	4-J6	OCP	2-J1
SLT LED	4-J6	OCP	2-J1

FROM DRIVE ELECTRONICS (ELEC) (Continued)

<u>Signal</u>	<u>From ELEC Sheet-Conn</u>	<u>To PCBA</u>	<u>Schematic Sheet-Conn</u>
LP LED	4-J6	OCP	
REUN LED			
LO LED			
ONLLED			
PE/1600 LED			
RMT LED			
DIAG LED			2-J1
WRP			1-J1
DB(0-5)			1-J1
DB6			1-J1
3200 LED	4-J6	OCP	2-J1
TU OFSE	5-J3	SERVPRE	4-J1
SUP OFSE			3-J1
VEL TUP			4-J1
VEL SUP		SERVPRE	3-J1
TU REFF	5-J5	INTCON	1-J1
SUP REFF	5-J5	INTCON	1-J1
SUMPT CPST	6-J3	SERVPRE	1-J1
E TU POS	7-J3		4-J1
E TU VL			4-J1
E SU POS			3-J1
E SU VL			3-J1
VAC MOT			1-J1
ENB CPST	7-J3		
BRAKE	9-J3		
SERVO EN	9-J3		1-J1
CUR SUP	7-J3		3-J1
CUR TUP	7-J3	SERVPRE	4-J1
HUB LOK SOL	8-J2	INTCONN	2-J2
DOOR LOK SOL			2-J2
+24V			2-J2
GND	8-J2		2-J2
OPTSW	10-J2		2-J2
MICSW	10-J2	INTCONN	2-J2

TO DRIVE ELECTRONICS (ELEC)

<u>Signal</u>	<u>From Sheet-Conn</u>	<u>On PCBA</u>	<u>To ELEC Sheet-Conn</u>
FDB(0-7)	10-P1	FMTR	3-P1
FSEL(0, 1)	10-P1		
FMTR STRB	11-P1		
FMTR BUSY			
FBGRANT			
FMTR ACKN	11-P1	FMTR	3-P1
TARMOT	2-J2	INTCON	10-J2
SURMOT	2-J2	INTCON	10-J2
REUN PB	2-J1	OCP	4-J6
LOAD PB			
ONL PB			
DEN PB	2-J1	OCP	4-J6

TO DRIVE ELECTRONICS (ELEC) (Continued)

<u>Signal</u>	<u>From Sheet-Conn</u>	<u>On PCBA</u>	<u>To ELEC Sheet-Conn</u>
RST PB	2-J1	OCF	4-J6
STRT PB			
SCAN PB			
DIAG PB	2-J1		4-J6
DSP FUL	1-J1	OCF	2-J6
TPHA		INTCON	4-J5
TPHB			4-J5
SUP POS			7-J5
TUP POS	1-J1	INTCON	
TUP MOV	4-J1	SERVPRE	
SUP MOV	3-J1	SERVPRE	7-J3

FROM OPERATOR CONTROL PANEL (OCP)

<u>Signal</u>	<u>From OPC Sheet-Conn</u>	<u>To:</u>	<u>Sheet-Conn</u>
REUN PB	2-J1	ELEC	4-J6
LOAD PB			
ONL PB			
DEN PB			
RST PB			
STRT PB			
SCAN PB			
DIAG PB	2-J1		
DSP FUL	1-J1	ELEC	4-J6

TO OPERATOR CONTROL PANEL (OCP)

<u>Signal</u>	<u>From Sheet-Conn</u>	<u>On PCBA</u>	<u>To OCP Sheet-Conn</u>
DB(0-6)	4-J6	ELEC	1-J1
WRP			1-J1
NRZ LED			2-J1
WEN LED			
SLT LED			
LP LED			
PWR ON LED			
REUN LED			
LO LED			
ON LED			
PE LED			
RMT LED			
STRT LED	4-J6	ELEC	2-J1

FROM READ ANALOG BOARD (READA)

<u>Signal</u>	<u>From READA Sheet-Conn</u>	<u>To:</u>	<u>Schematic Sheet-Conn</u>
EGC(1-9)	4-J1	READPRE	1-P2
ENV(0-7,P)	7-P2	READD	11-P2
TD(0-3)		DIG R/W	7-P2
TD(4-6)		DIG R/W	8-P2
TD(7, P)	7-P2	DIG R/W	9-P2

TO READ ANALOG BOARD (READA)

<u>Signal</u>	<u>From Sheet-Conn</u>	<u>On PCBA</u>	<u>To READA Sheet-Conn</u>
FSEL(2-6)	10-P1	FMTR	2-P1
FDB(0-7)	10-P1	FMTR	3-P1
FMTR STRB	11-P1	FMTR	2-P1
PE BLOCK	10-P1	DIG R/W	5-P1
HD(0-7,P)	15-P2	DIG R/W	8-P2
TRK(1-9)+	1-P2	READPRE	6-J1
TRK(1-9)-	1-P2	READPRE	6-J1

FROM READ PREAMPLIFIER (READPRE)

<u>Signal</u>	<u>From READPRE Sheet-Conn</u>	<u>To:</u>	<u>Sheet-Conn</u>
TRK(1-9)+	1-P2	READA	6-J1
TRK(1-9)-	1-P2	READA	6-J1

TO READ PREAMPLIFIER (READPRE)

<u>Signal</u>	<u>From Sheet-Conn</u>	<u>On:</u>	<u>To READPRE Sheet-Conn</u>
EGC(1-9)	4-J1	READA	1-P2
TRK(1-9)+	4-J1	READ HEAD	1-P1
TRK(1-9)-	4-J1	READ HEAD	1-P1

FROM DIGITAL READ/WRITE BOARD (DIG R/W)

<u>Signal</u>	<u>From DIG R/W Sheet-Conn</u>	<u>To:</u>	<u>Sheet-Conn</u>
RD(0-7,P)	13-P2	FMTR	7-P2
CRECTD ERROR	10-P1		10-P1
HRD ERROR	12-P1		10-P1
RD DATA STRB	12-P2		9-P2
RD BUSY	3-P1		13-P1
FILE MARK	10-P1		10-P1
WRT BUSY	3-P1		13-P1
WRT DATA STRB	2-P1	FMTR	9-P2
HD(0-7,P)	15-P2	READA	8-P2
ERASE HD+	14-J2	Erase Head (Black)	
ERASE HD-	14-J2	Erase Head (White)	
TRK(1-9)	15-J1	Write Head	
WRT VOL	15-J1	Write Head	

TO DIGITAL READ/WRITE BOARD (DIG R/W)

<u>Signal</u>	<u>From Sheet-Conn</u>	<u>On PCBA</u>	<u>To DIG R/W Sheet-Conn</u>
MSTR RES	3-P1	ELEC	3-P1
TD(0-3)	7-P2	READA	7-P2
TD(4-6)	7-P2		8-P2
TD(7,P)	7-P2		9-P2
ENV(0-7,P)	7-P2	READA	11-P2
FDB(0-7)	10-P1	FMTR	3-P1
FMTR STRB	11-P1		3-P1
FSEL(0-6)	10-P1		3-P1
WD(0-7)	6-P1		5-P1
ERASE PWR EN	13-P1		14-P1
WRT PWR EN	13-P1		14-P1
LST WORD	8-P1	FMTR	5-P1

FROM SERVO PREAMPLIFIER (SERVPRE)

<u>Signal</u>	<u>From SERVPRE Sheet-Conn</u>	<u>To:</u>	<u>Sheet-Conn</u>
VAC MOT	1-J3	SERVPA	3-J3
SUMPT CPST	1-J3		3-J3
ABRAKE	1-J3		3-J3
SERVO EN	1-J3		2-J3
ENB CPST	1-J3		2-J3
OSC	2-J3		3-J3
-REF	2-J3		4-J3
+REF	2-J3		
SUP MOD	3-J3		
TUP MOD	4-J3	SERVPA	4-J3
SUP MOV	3-J1	ELEC	8-J3
TUP MOV	4-J1	ELEC	8-J3

TO SERVO PREAMPLIFIER (SERVPRE)

<u>Signal</u>	<u>From Sheet-Conn</u>	<u>On PCBA</u>	<u>To SERVPRE Sheet-Conn</u>
VAC MOT	8-J3	ELEC	1-J1
SUMPT CPST	7-J3		
ENB CPST	8-J3		
BRAKE	8-J3		
SERVO EN	8-J3		1-J1
SUP OFSE	6-J3		3-J1
E SU POS	8-J3		
E SU VL	8-J3		
SUP OFST	6-J3		
CUR SUP	8-J3		
CUR SUP GND	8-J3		
VEL SUP	6-J3		3-J1
TU OFSE	6-J3		4-J1
E TU POS	8-J3		
E TU VL	8-J3		
CUR TUP	8-J3		
CUR TUP GND	8-J3		
TU OFST	8-J3		
VEL TUP	6-J3	ELEC	4-J1

SECTION VIII
APPENDIX

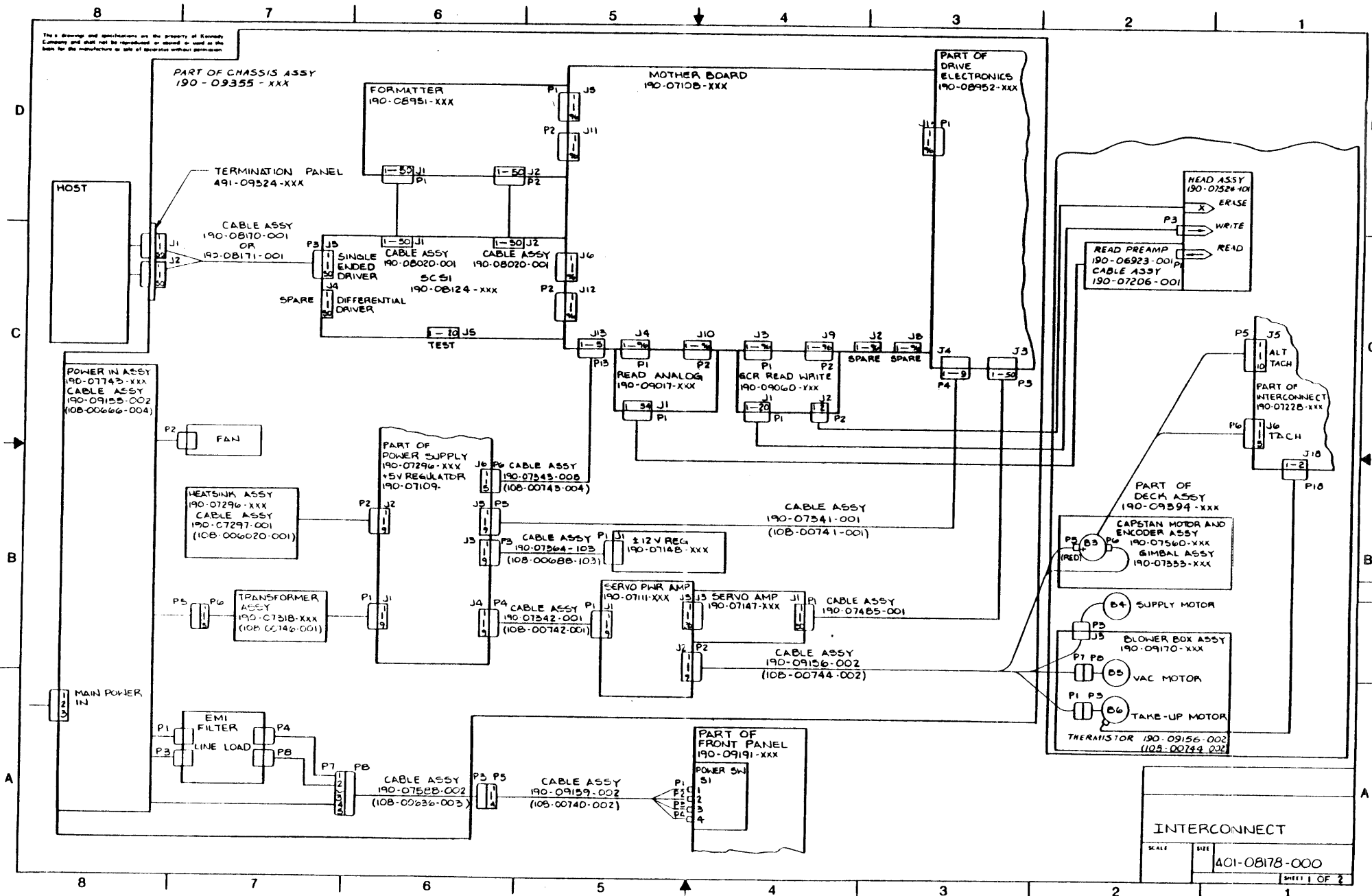

INTERCONNECT	
SCALE	SIZE
	401-08178-000
SHEET 1 OF 2	

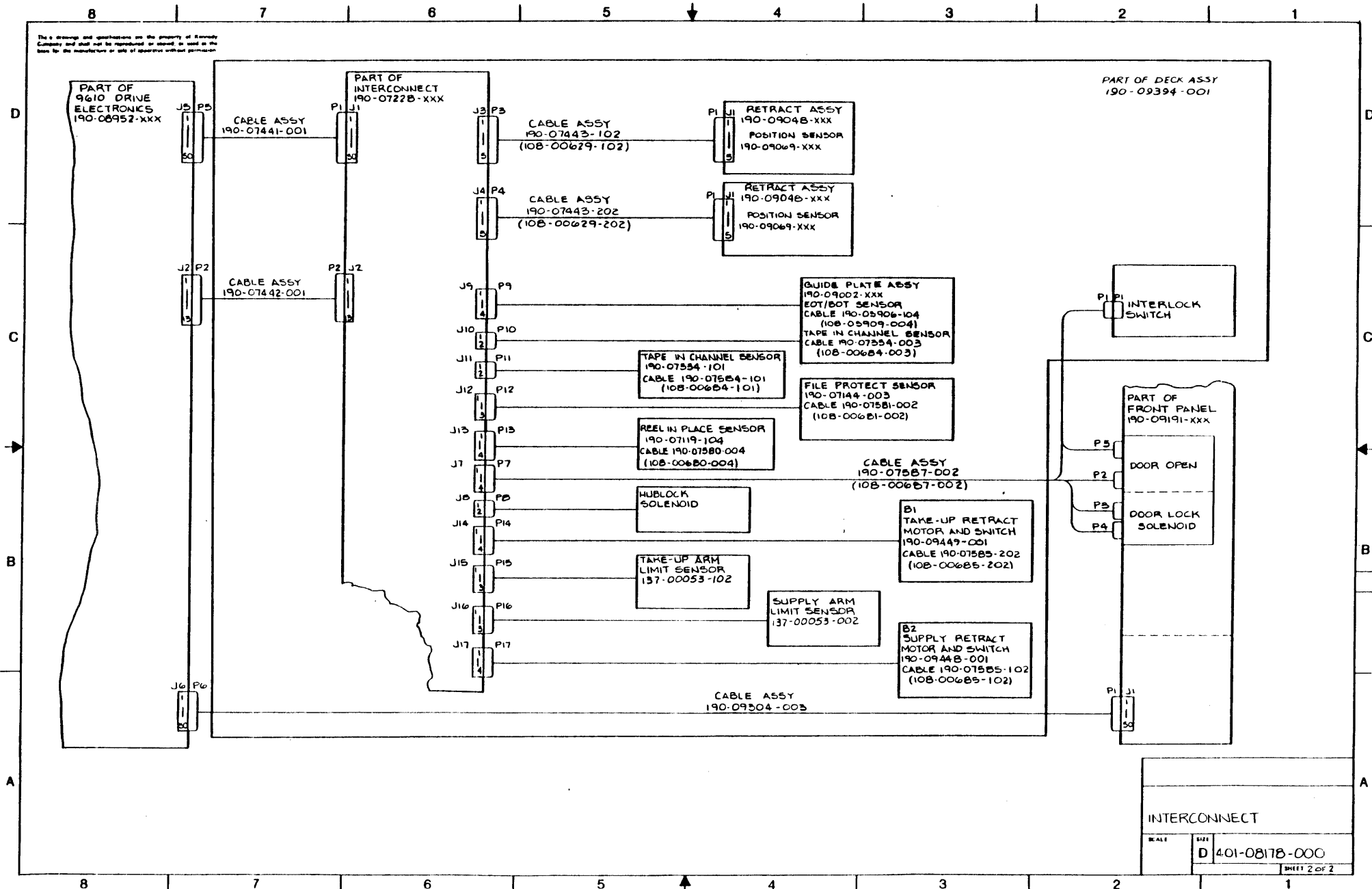

INTERCONNECT	
SCALE	SIZE
	D
401-08178-000	
SHEET 2 OF 2	

These drawings and specifications are the property of Armyco Company and shall not be reproduced or used in the field for the manufacture or use of electrical equipment.

190-7109 TABULATION

DRSH NO	REV
-007	C

A

B

C

D

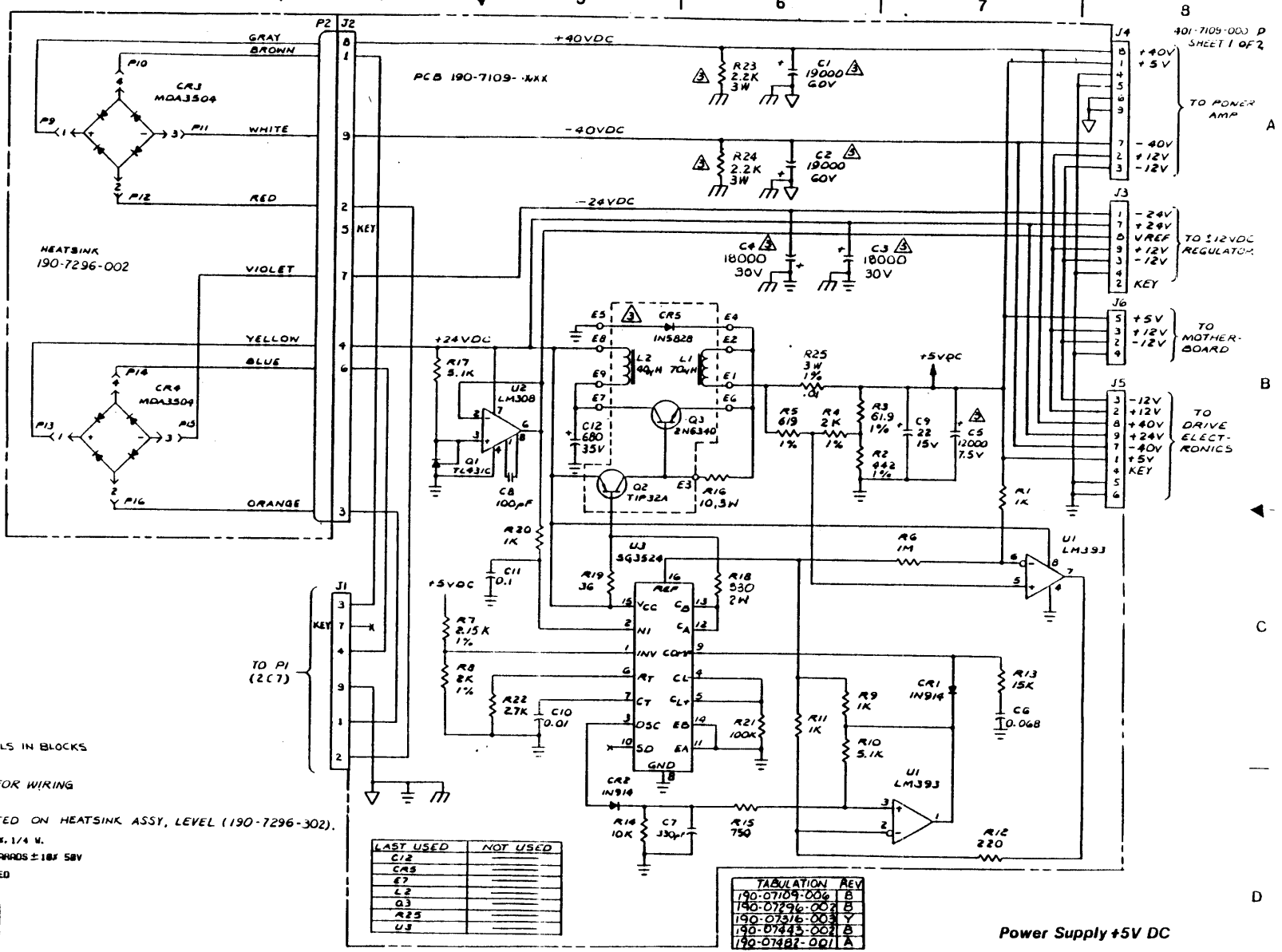

▲ LETTERS AND SYMBOLS IN BLOCKS ARE TERMINALS.

6. REF 108-0666-001

5. SEE 190-7145-001 FOR WIRING

▲ REMOVED

▲ COMPONENTS MOUNTED ON HEATSINK ASSY, LEVEL (190-7296-302).

2. RESISTORS ARE IN OHMS ± 5%, 1/4 W.

1. CAPACITORS ARE IN MICROFARADS ± 10% 50V

NOTES: UNLESS OTHERWISE SPECIFIED

REV STATUS OF SHEETS	REV	P	P
	SHEET	1	2

LAST USED	NOT USED
C12	
C15	
E7	
Q3	
R25	
U3	

TABULATION	REV
190-07109-006	B
190-07296-002	B
190-07316-003	Y
190-07445-002	B
190-07487-001	A

Power Supply +5V DC
TYPE 7109,7296,7443,7339,7482
Schematic Diagram

These drawings and specifications are the property of Honeywell Company and shall not be reproduced or copied or used in the form for the manufacture or sale of apparatus without permission.

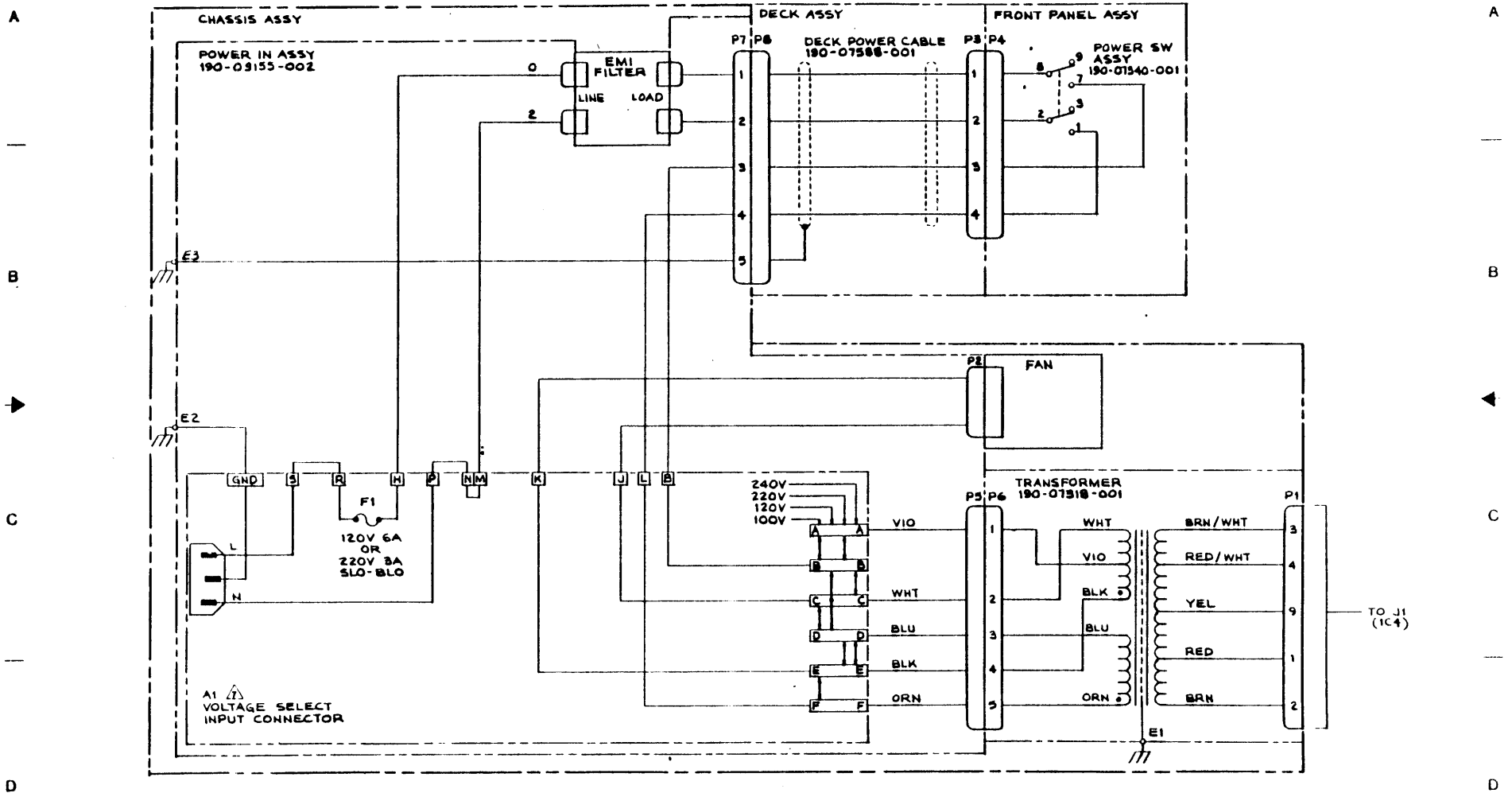

Power Supply +5V DC
TYPE 7109,7296,7443,7339,7482
Schematic Diagram

1 | 2 | 3 | 4 | 5 | 6 | 7 | 8

These drawings and specifications are the property of Honeywell Company and shall not be reproduced or copied or used in any form for the manufacture or sale of apparatus without permission.

401-7148-000 D
SHEET 1 OF 1

90-07148-XXX TABULATION

REF DES	DASH NO	REV
	-004	C

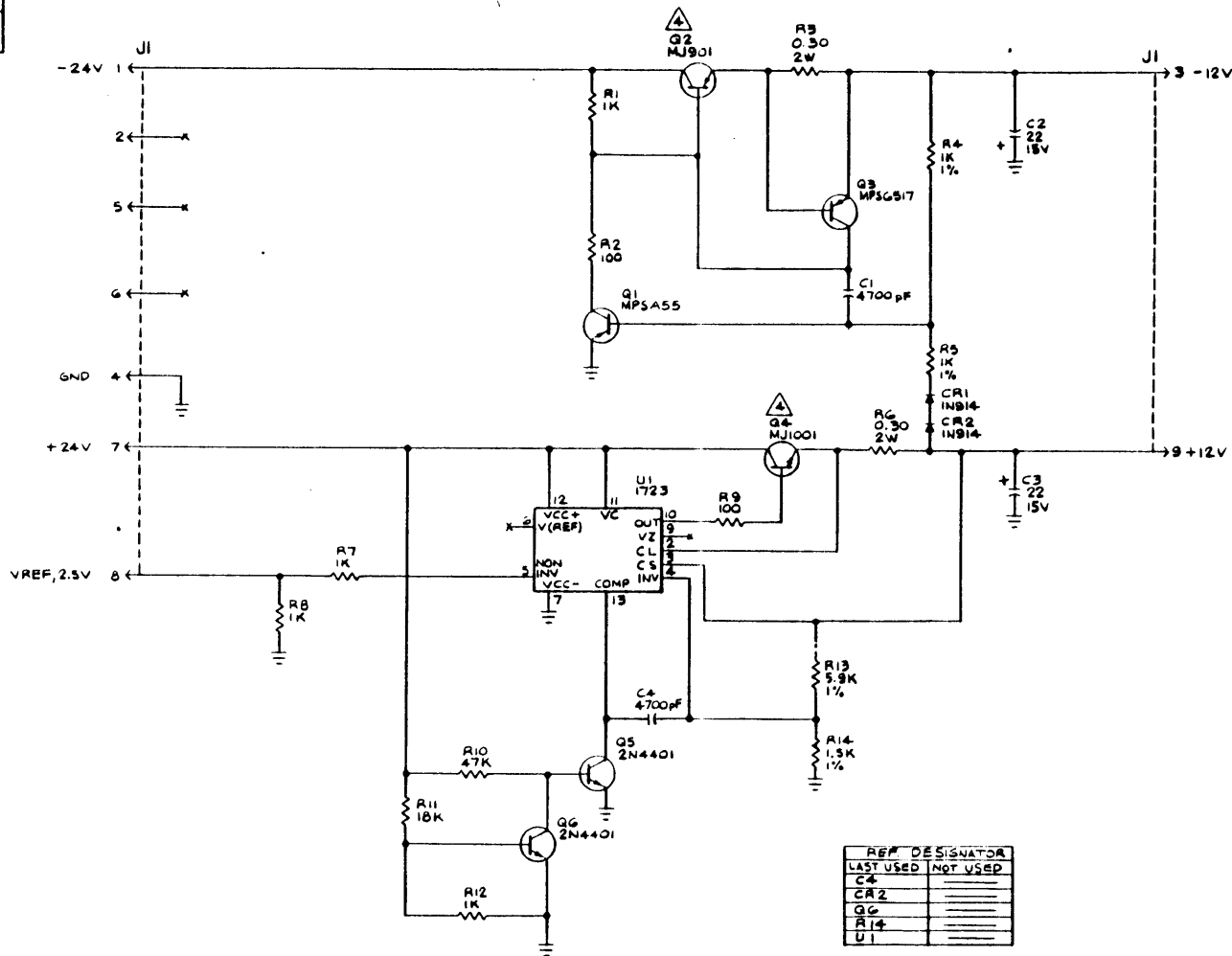

REF DESIGNATOR	
LAST USED	NOT USED
C4	
CR2	
Q6	
R14	
U1	

▲ MOUNT ON HEAT SINK 304-7295-001.
 3 ALL CAPACITOR VALUE ARE IN MICROFARADS.
 2 ALL RESISTOR VALUE ARE IN OHMS ±5% 1/4W.
 1 X INDICATES NO CONNECTION.
 NOTES: UNLESS OTHERWISE SPECIFIED.

± 12V Regulator
 Type 7148
 Schematic Diagram

1 | 2 | 3 | 4 | 5 | 6 | 7 | 8

These drawings and specifications are the property of Boeing Company and shall not be reproduced or copied, in whole or in part, for the manufacture or use of apparatus without permission.

SEE SHEET 2 FOR TABULATION BLOCK

401-07228-0006
SHEET 1 OF 2

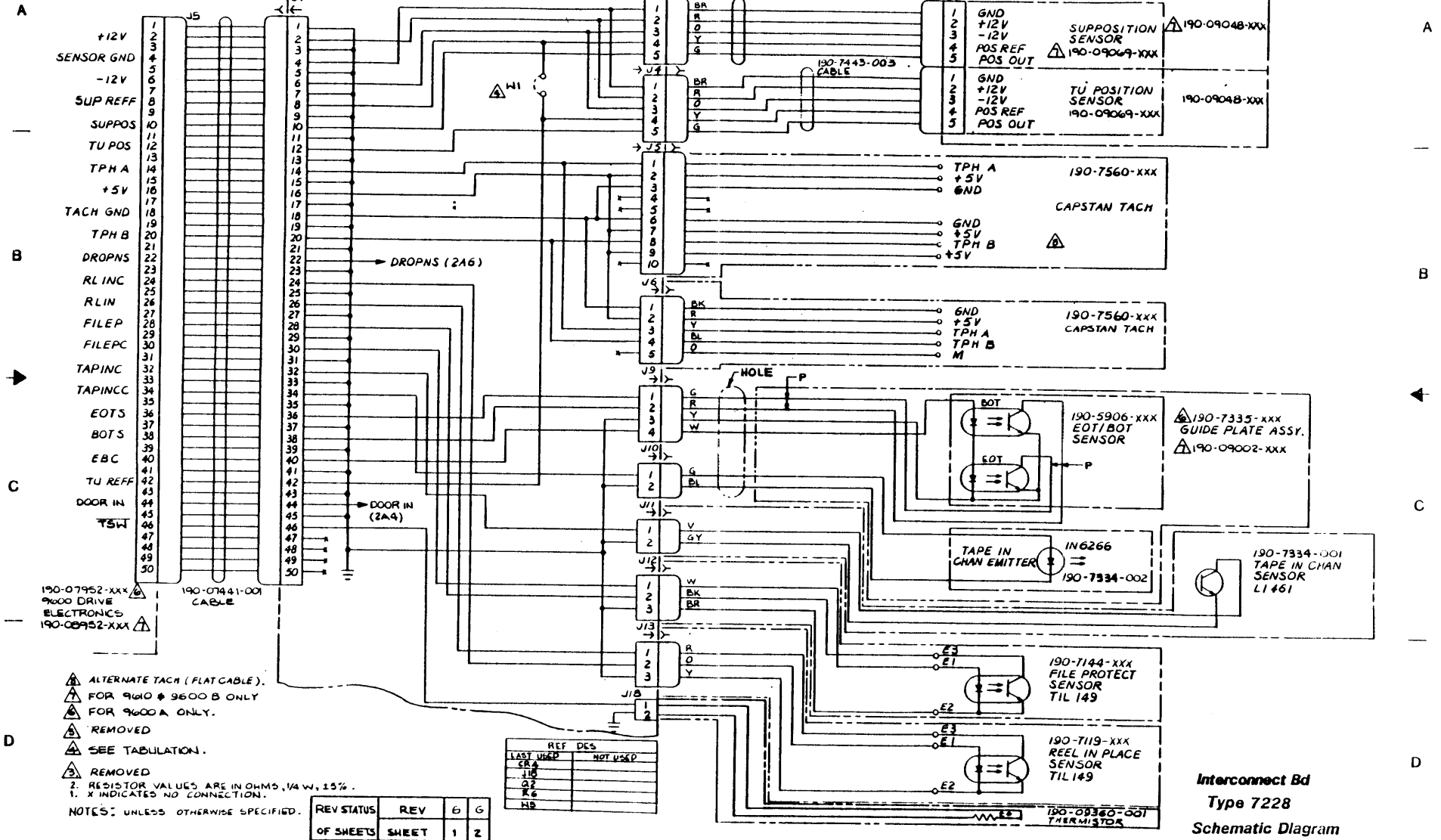

These drawings and specifications are the property of Kennedy Company and shall not be reproduced or copied in whole or in part for the manufacture or use of apparatus without permission.

401-07228-0000- SHEET 2 OF 2

REF DES	DASH NO	REV	DASH NO	REV	DASH NO	REV
		-102	A	-202	A	-301
(W1)	W1					
(W2)					W2	
(W3)	W3		W3			

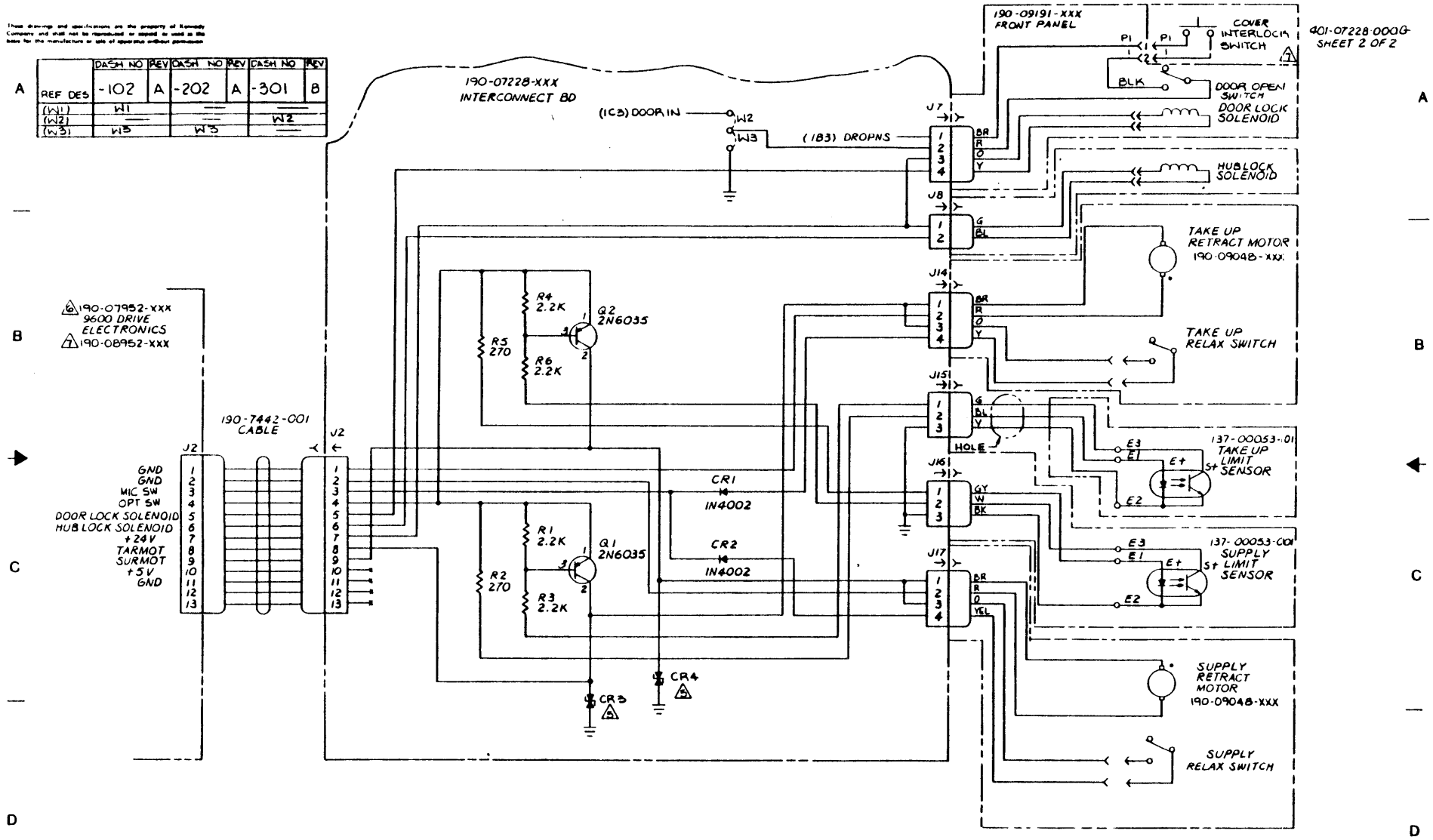

Interconnect Bd
Type 7228
Schematic Diagram

This drawing and specifications are the property of Kennedy Company and shall not be reproduced or copied in whole or in part for the manufacture or use of apparatus without permission.

401-09069-000 E
SHT 1 OF 1

90-09069-XXX TABULATION

REF DES	QASH NO	REV	DASH NO	REV
(W1)	-004	C	-104	A
	W1			

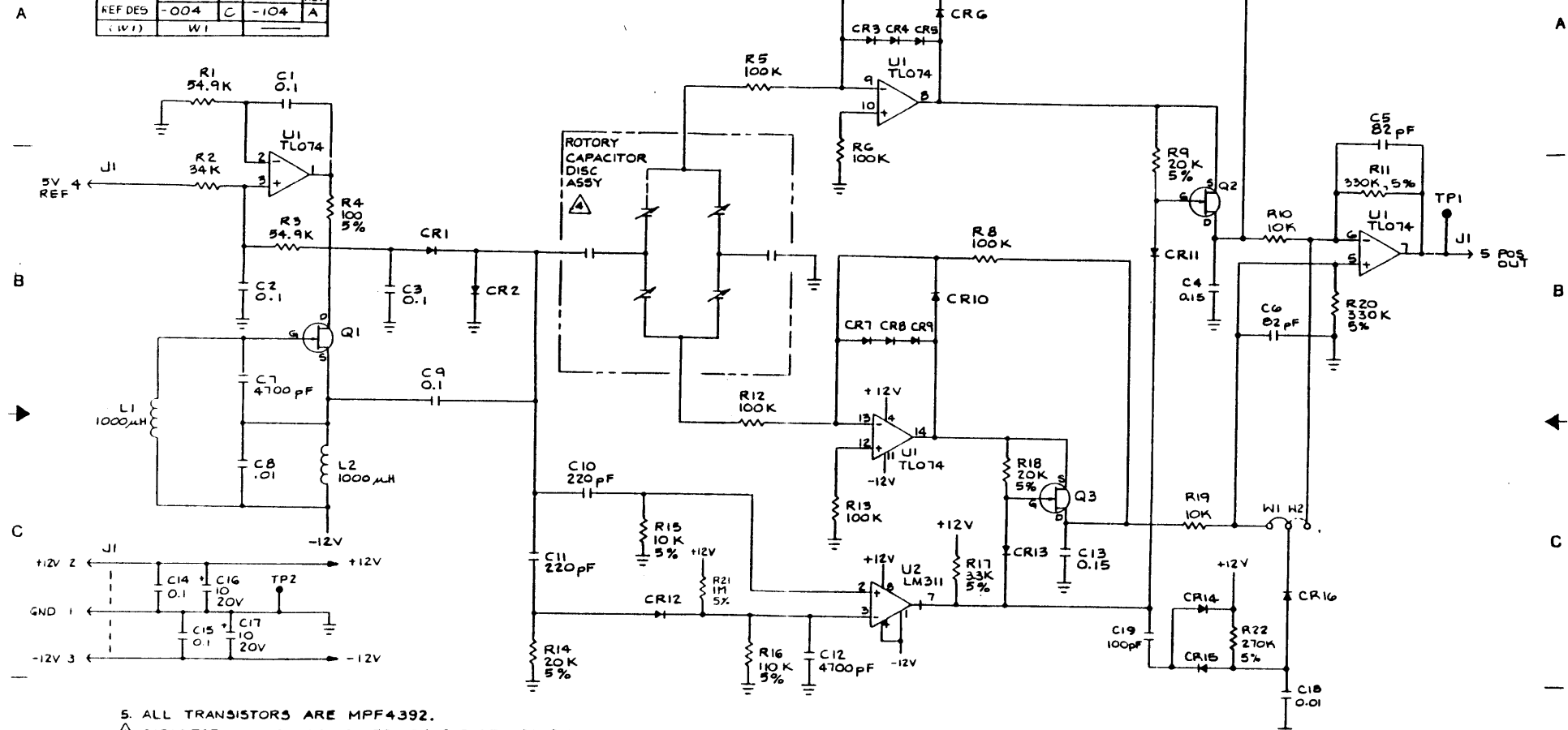

- 5. ALL TRANSISTORS ARE MPF4392.
 - △ CAPACITOR VALUES ARE CREATED BY CAPACITANCE DISC 204-TT09-001.
 - 3. ALL DIODES ARE 1N914.
 - 2. RESISTORS ARE IN OHMS 1/10W, 1%.
 - 1. CAPACITORS ARE IN MICROFARADS ± 10% 50V.
- NOTES: UNLESS OTHERWISE SPECIFIED.

REF DESIGNATORS	LAST USED	NOT USED
C19		
CR16		
Q2		
Q3		
R12		
TP2		
U2		

REV STATUS OF SHEETS	REV SHEET	E
		1

POSITION SENSOR
TYPE 9069
SCHEMATIC DIAGRAM

These drawings and specifications are the property of Kennedy Company and shall not be reproduced or used in any form for the manufacture in any of operations without permission.

401-07947-000 H
SHEET 1 OF 2

90-07947 TABULATION

REF DES	DASH NO	REV	DASH NO	REV	DASH NO	REV
DSG	-102	A	-203	A	-312	B
DS12	1.5 MCD		1.5 MCD	1.5 MCD		
DS13			1.5 MCD	1.5 MCD		
R20			220	220		
R21			220	220		
DS14			1.5 MCD	1.5 MCD		
DS15			1.5 MCD	1.5 MCD		
DS1	1.5 MCD		1.5 MCD			

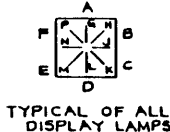
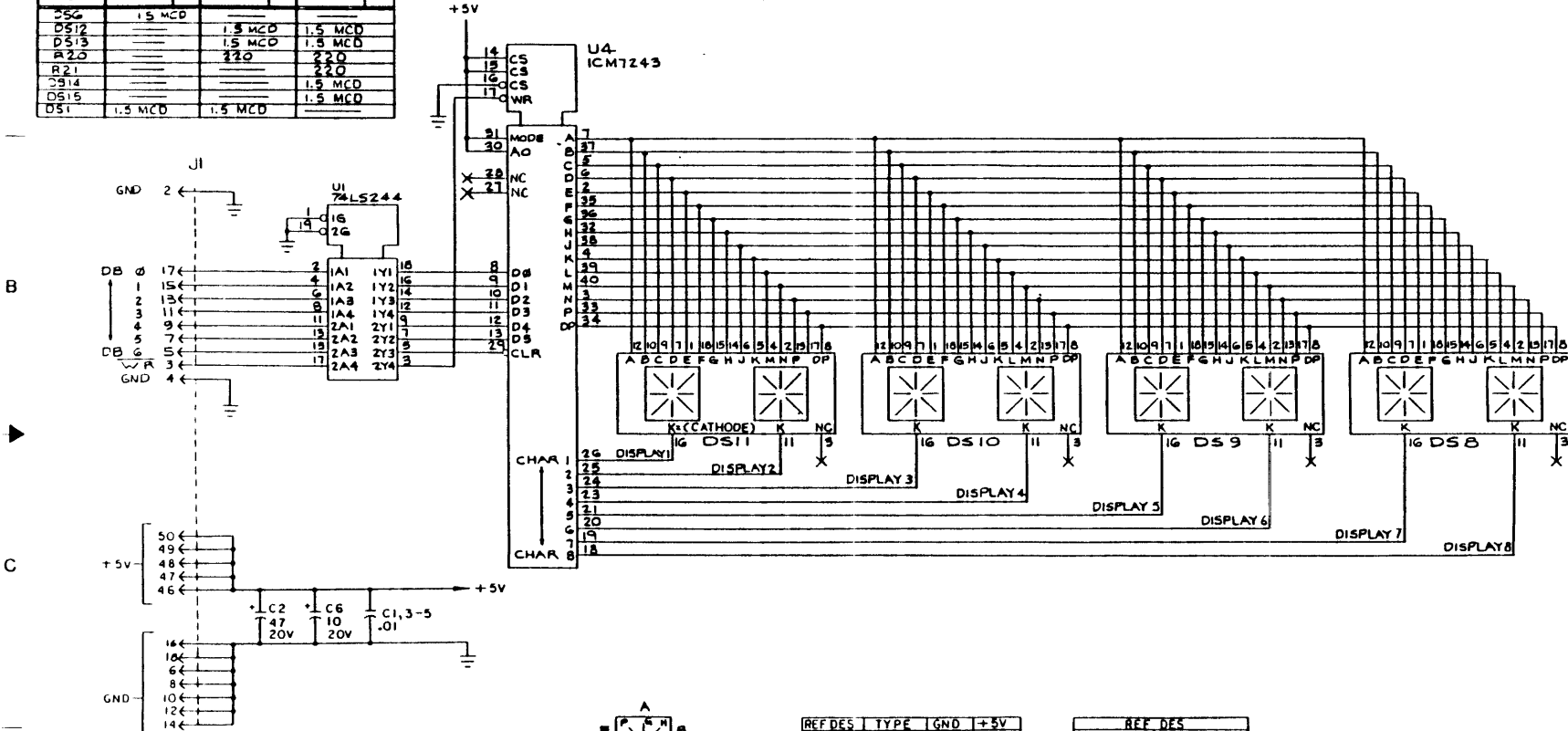

REF DES	TYPE	GND	+5V
U2,3	7406	7	14
U4	7243	22	1
U1	74LS244	10	20

REF DES	
LAST USED	NOT USED
C6	
DS15	
J1	
R21	
S8	
U4	

- SEE TABULATION FOR COMPONENTS USED.
- ALL DIODES ARE 1.5 MCD
 - RESISTORS ARE IN OHMS 1/4 W.
 - CAPACITORS ARE IN MICROFARADS 18V 50V

NOTES: UNLESS OTHERWISE SPECIFIED

REV STATUS OF SHEETS	REV SHEET	H	D
	1	1	2

OPERATOR CONTROL PANEL
TYPE 7947
SCHEMATIC DIAGRAM

These drawings and specifications are the property of Remco Company and shall not be reproduced or copied or used as the basis for the manufacture or sale of apparatus without permission.

401-07947-000 D
SHEET 2 OF 2

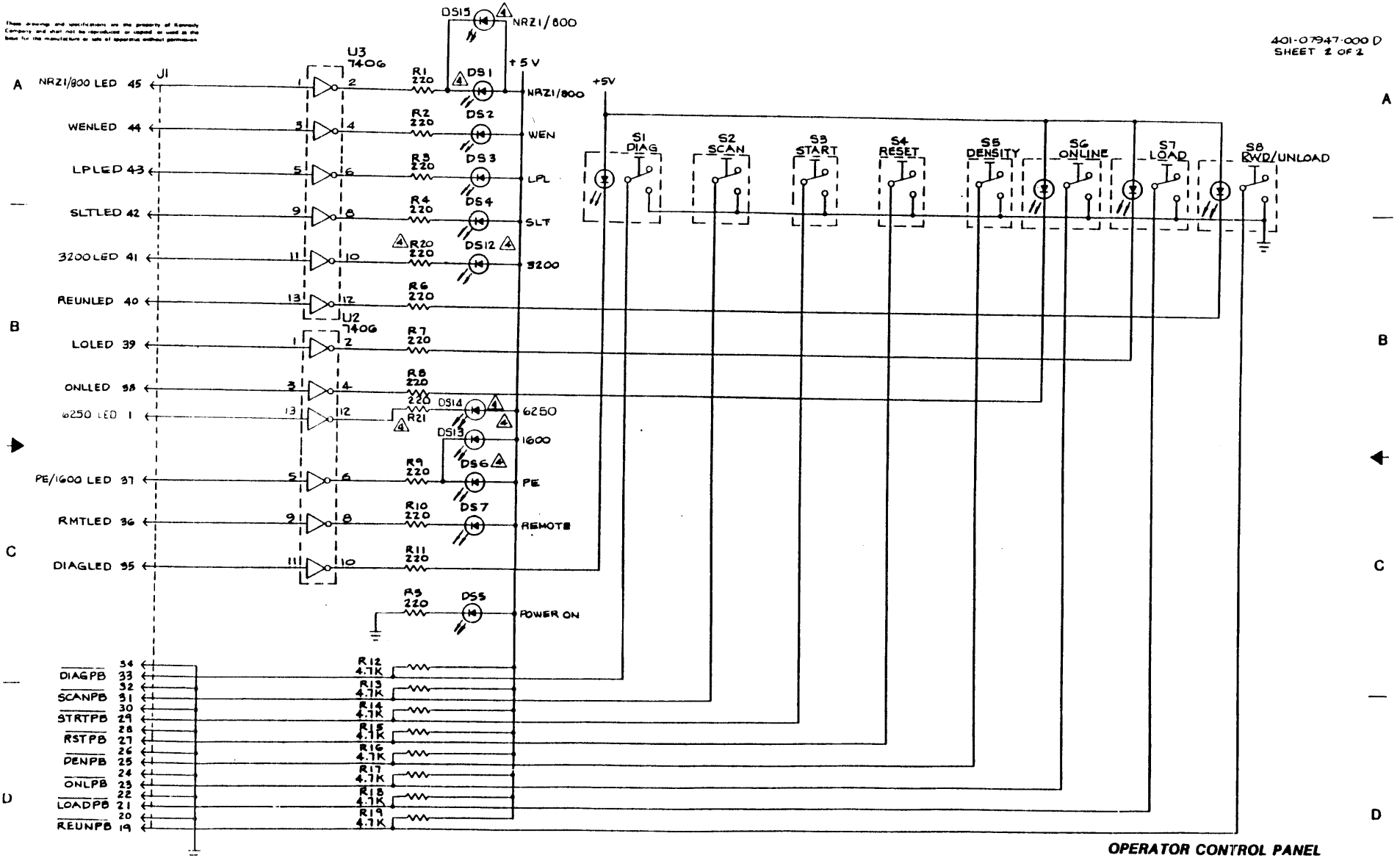

OPERATOR CONTROL PANEL
TYPE 7947
SCHEMATIC DIAGRAM

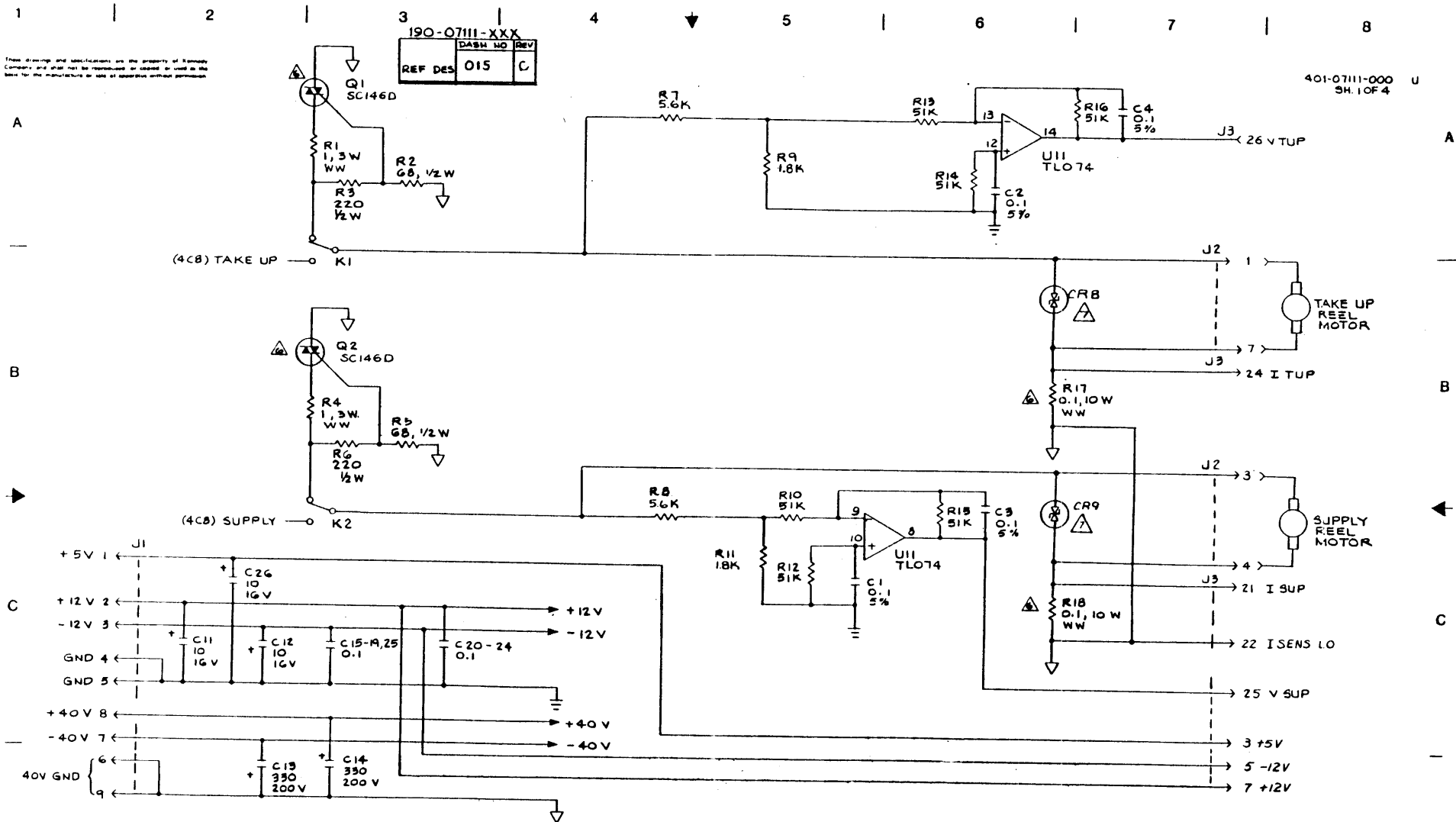

These drawings and specifications are the property of Kennedy Company and shall not be reproduced or copied or used in the base for the manufacture or sale of equipment without permission.

401-07111-000 U
SH. 1 OF 4

- D
- △ COMPONENTS NOT USED, SHOWN FOR FULL CAPABILITY OF THE BOARD.
 - ▲ COMPONENTS MOUNTED ON HEAT SINK. 190-7289-001
 - 5 SEE SH. 4 FOR NOTES ON TYPICAL SECTION.
 - 4 ALL DIODES ARE IN1914
 - 3 X INDICATES NO CONNECTION.
 - 2 ALL RESISTOR VALUES ARE IN OHMS ± 5% 1/4 W.
 - 1 ALL CAPACITOR VALUES ARE IN MICROFARADS.
- NOTES: UNLESS OTHERWISE SPECIFIED

REF. DESIG.	
LAST USED	NOT USED
C28	CB, 9, C27
CR10	
K2	
L1	
Q3	
R7	R51, 58
U5	U2, 10

REV STATUS	REV	L P P P			
		1	2	3	4
OF SHEETS	SHEET	1	2	3	4

Servo Power Amplifier
Type 7111
Schematic Diagram

These drawings and specifications are the property of Remco Company and shall not be reproduced or copied in whole or in part for the manufacture or use of duplicate without permission.

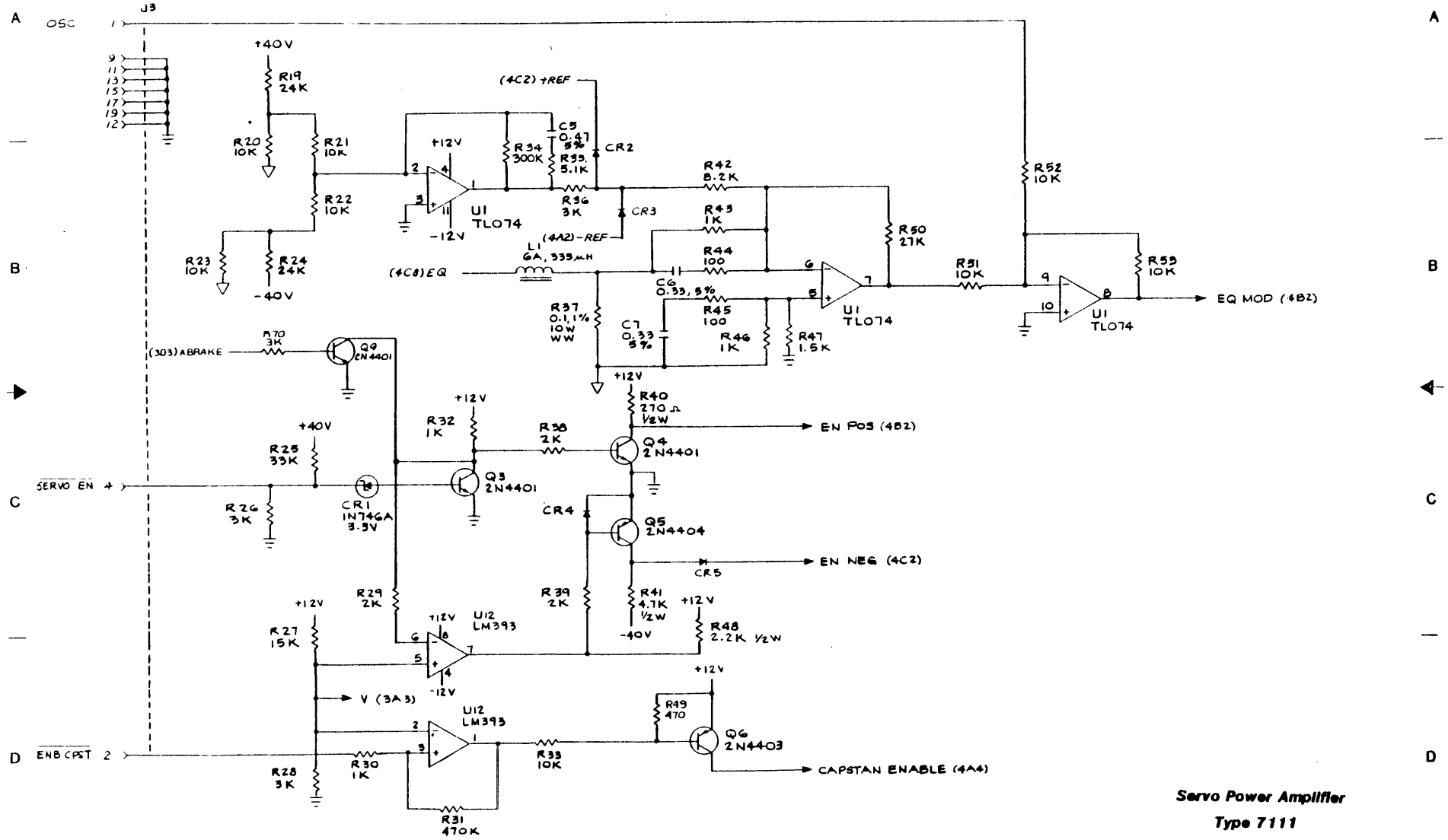

Servo Power Amplifier
Type 7111
Schematic Diagram

1 | 2 | 3 | 4 | 5 | 6 | 7 | 8

These drawings and specifications are the property of Kennedy Company and shall not be reproduced or used in the same form for the manufacture or use of apparatus without permission.

401-07111-000 P
SH 3 OF 4

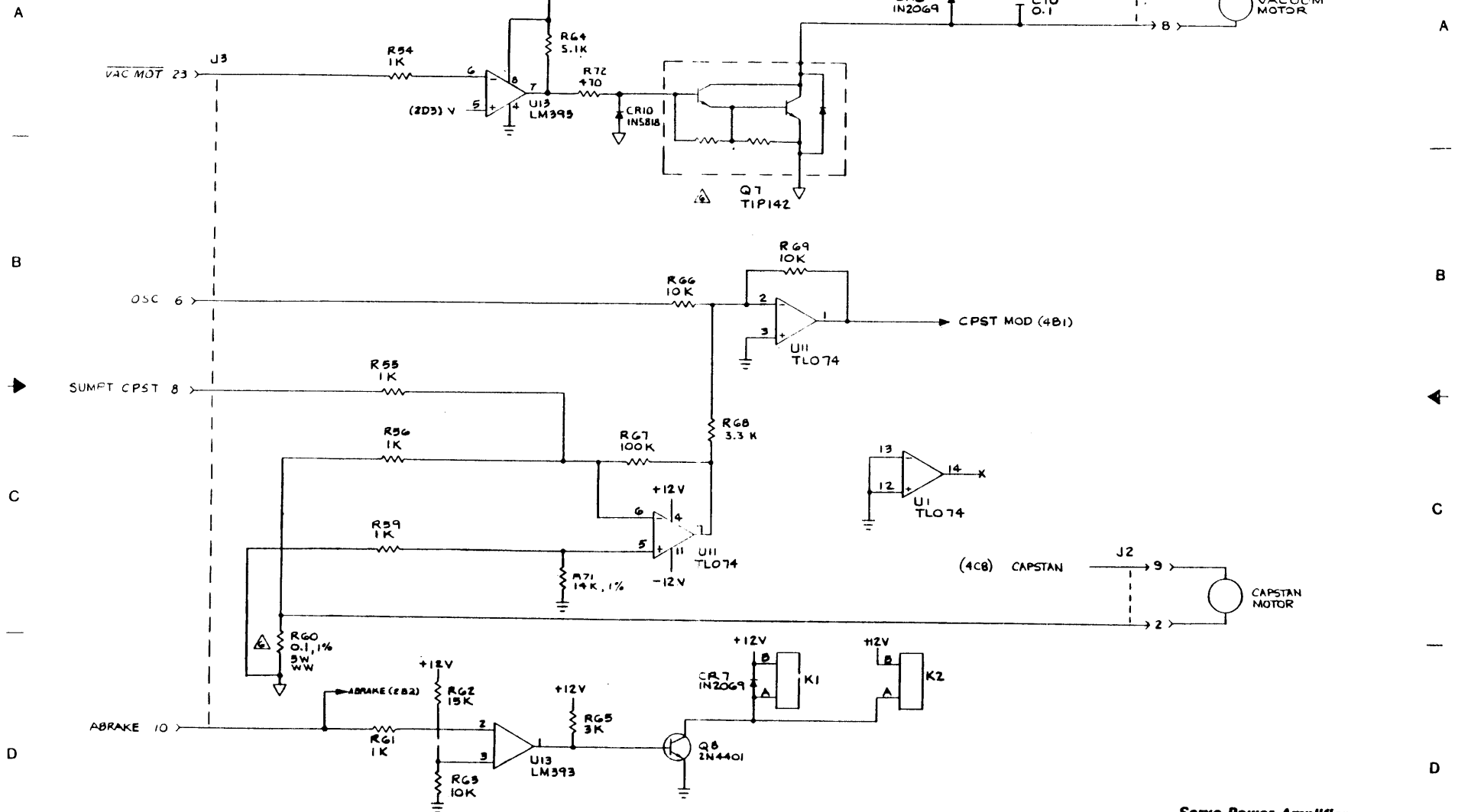

Servo Power Amplifier
Type 7111
Schematic Diagram

1 | 2 | 3 | 4 | 5 | 6 | 7 | 8

1 | 2 | 3 | 4 | 5 | 6 | 7 | 8

This drawing and specifications are the property of Kennedy Company and shall not be reproduced or copied in whole or in part for the manufacture or use of apparatus without permission.

401-07111-000 P
SH 4 OF 4

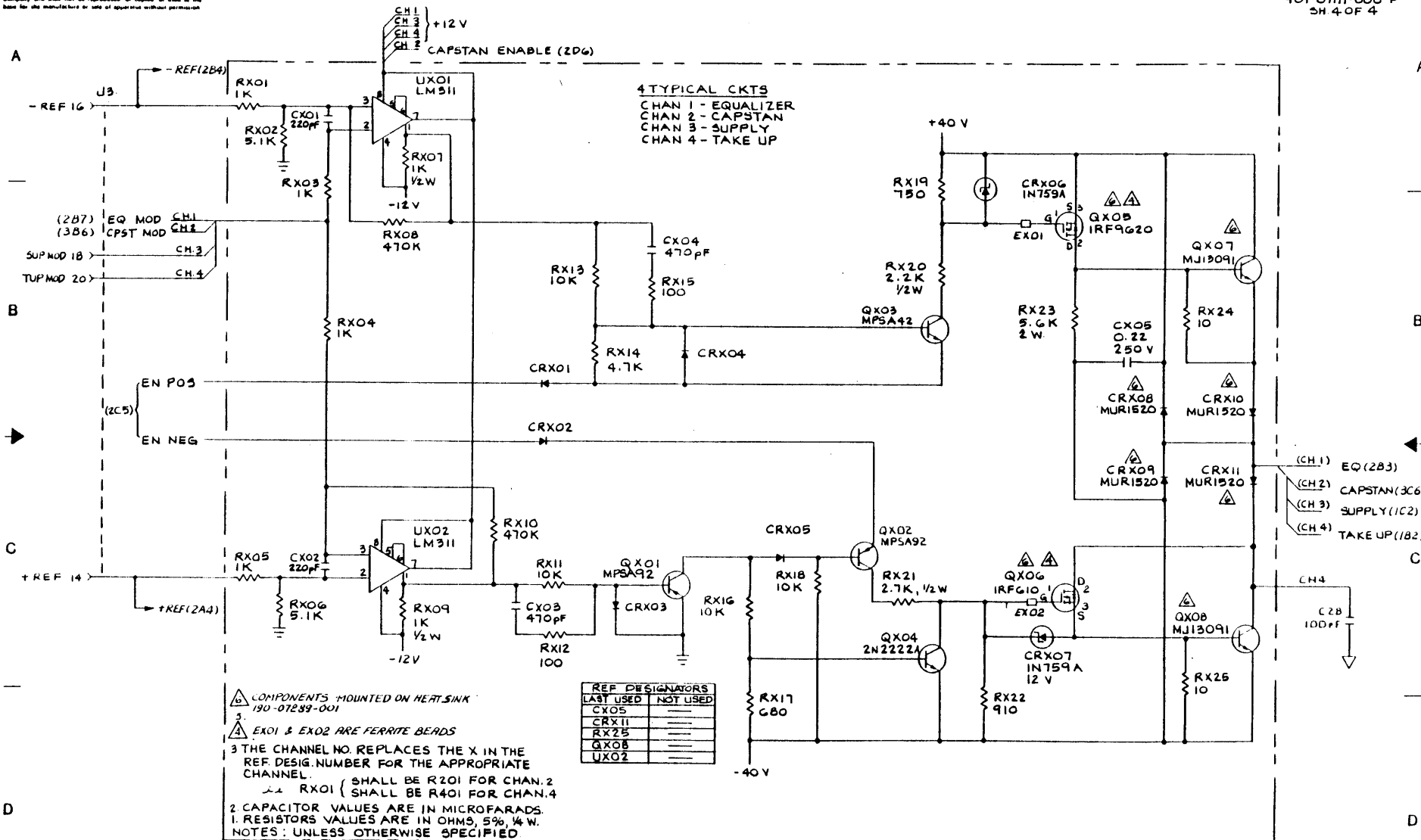

Servo Power Amplifier
Type 7111
Schematic Diagram

1 | 2 | 3 | 4 | 5 | 6 | 7 | 8

1 | 2 | 3 | 4 | 5 | 6 | 7 | 8

These drawings and specifications are the property of Kennedy Company and shall not be reproduced or copied or used in the base for the manufacture or sale of apparatus without permission

401-7147-000 D
SHT. 2 OF 4

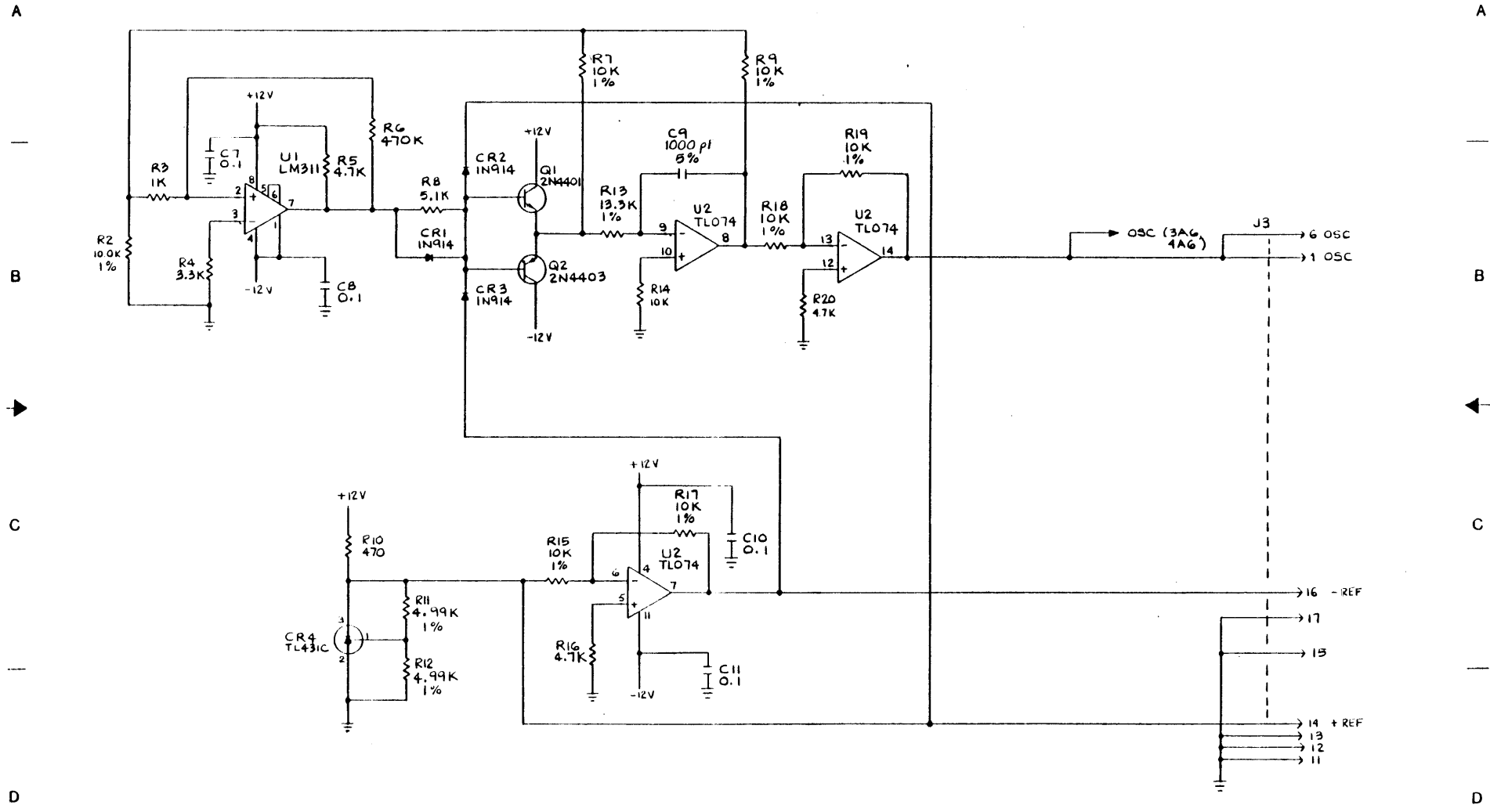

Servo Power Amplifier
Type 7147
Schematic Diagram

1 | 2 | 3 | 4 | 5 | 6 | 7 | 8

These drawings and specifications are the property of Kennedy Company and shall not be reproduced or copied or used in the base for the manufacture or sale of apparatus without permission.

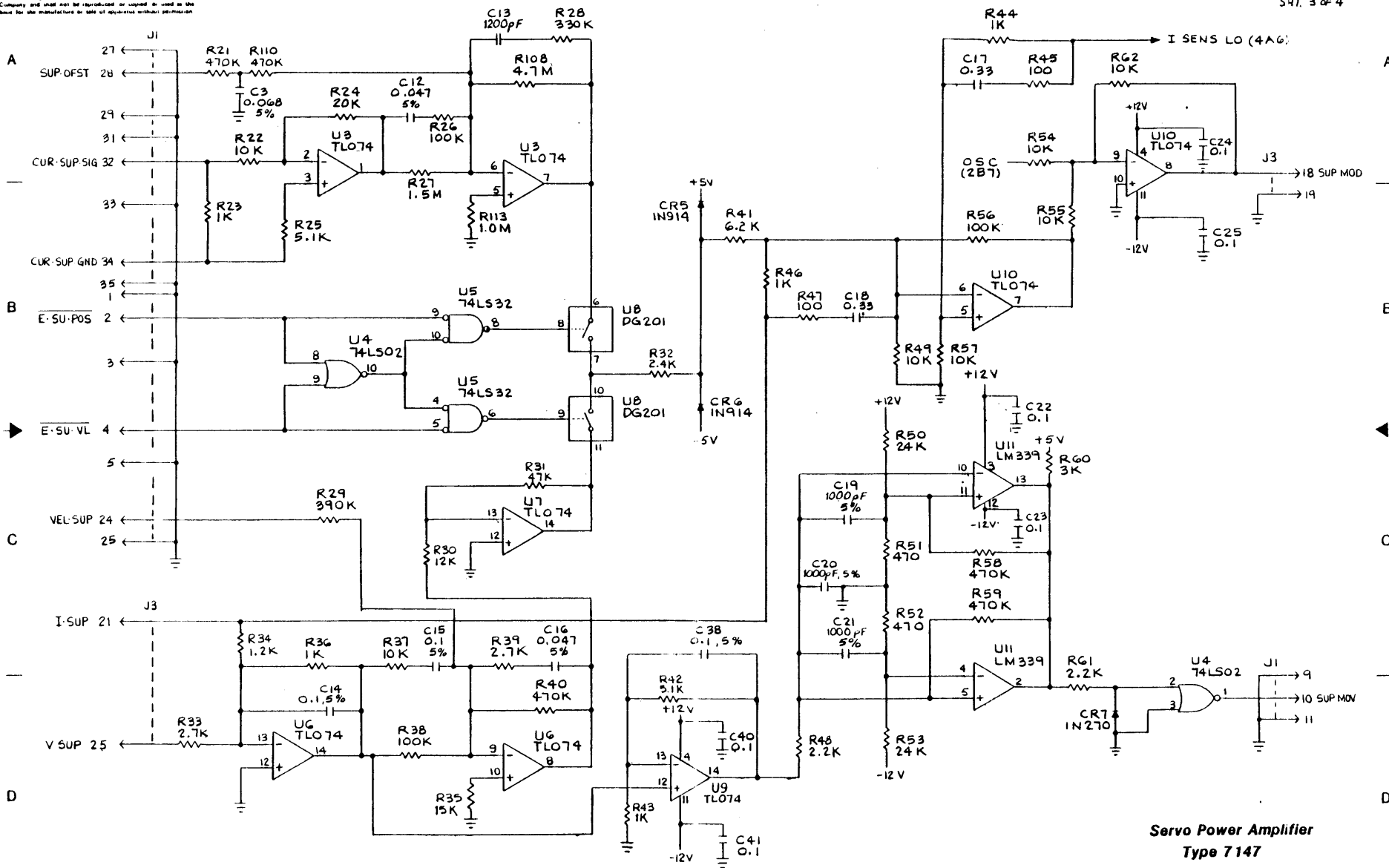

**Servo Power Amplifier
Type 7147
Schematic Diagram**

These drawings and specifications are the property of Remedy Company and shall not be reproduced or copied in whole or in part for the manufacture or sale of spares without permission.

401-7147-000 B
SHT. 4 of 4

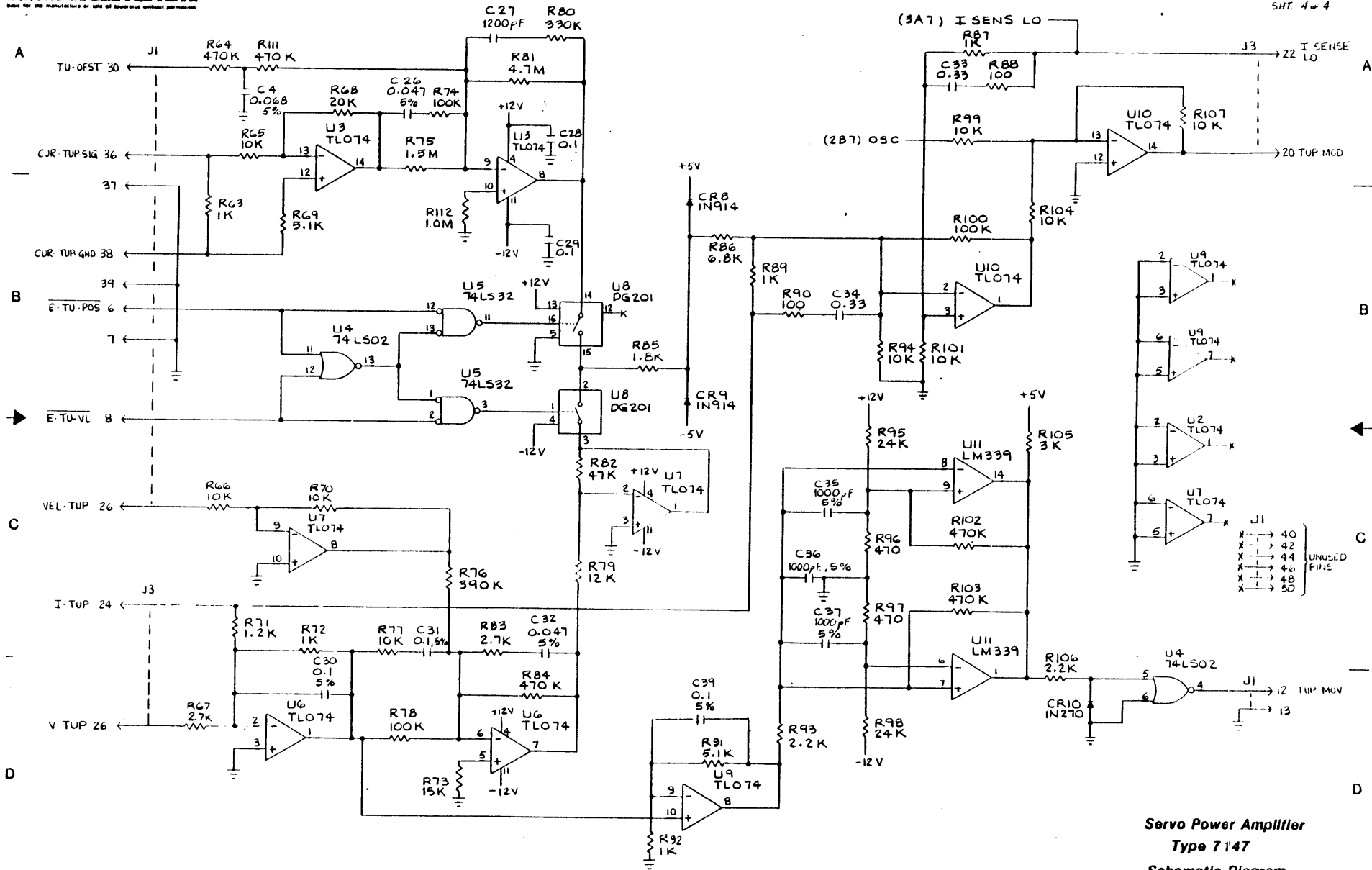

Servo Power Amplifier
Type 7147
Schematic Diagram

These drawings and specifications are the property of Seagate Technology and shall not be reproduced or copied or used in the manufacture of parts or assemblies without permission.

100-7108 TABULATION

A	DASH NO	REV
	-002	B

REF. PI

REF. PI

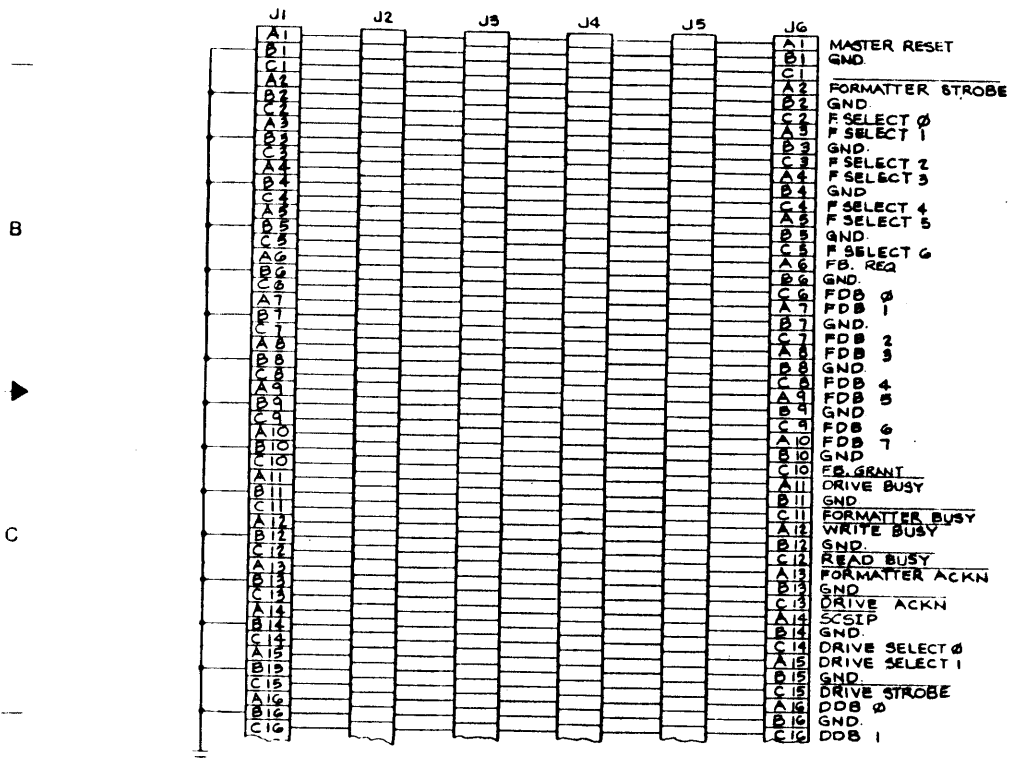

CONTINUATION

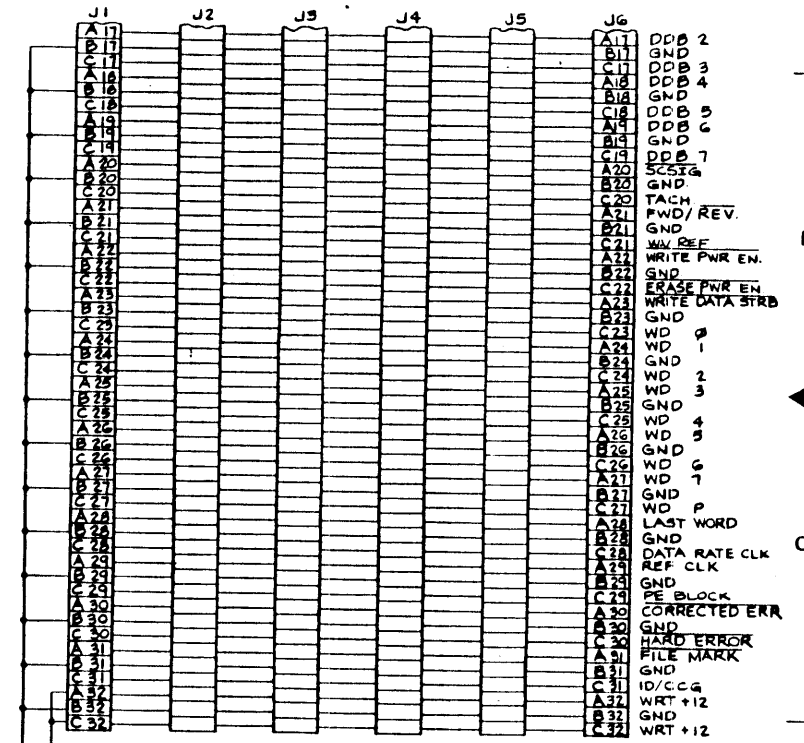

WRT +12
(TO SHT. 2)

REV STATUS OF SHEETS	REV SHEET	K	K
		1	2

D
3 A CHANGE TO THIS DRAWING SHALL REQUIRE COORDINATION WITH ALL ASSOCIATED DRAWINGS. ALL BOARDS PLUGGED INTO J2-J6 AND J8-J12 ON THE MOTHER BOARD SHALL HAVE CONNECTORS IDENTIFIED AS P1 AND P2. P1'S MATE WITH J2-J6. P2'S MATE WITH J8-J12. UNASSIGNED PINS ARE AVAILABLE FOR FUTURE USE.
NOTES UNLESS OTHERWISE SPECIFIED

REMOVED

9600 Motherboard Signal Assignments
Type 7108
Schematic Diagram

These drawings and specifications are the property of Kennedy Company and shall not be reproduced or copied in whole or in part for the manufacture or sale of apparatus without permission.

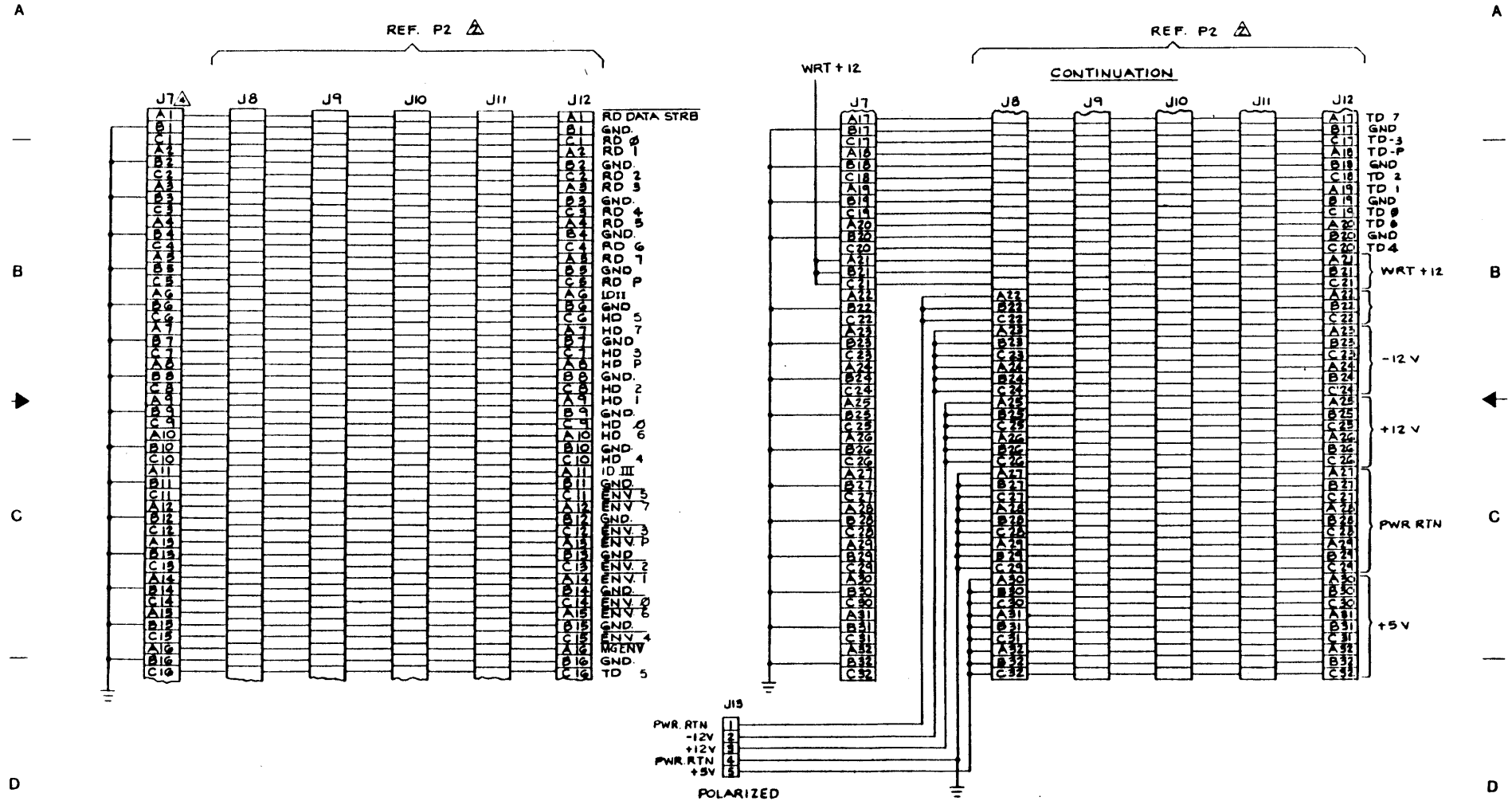

9600 Motherboard Signal Assignments
Type 7108
Schematic Diagram

These drawings and specifications are the property of Kennedy Company and shall not be reproduced, or copied, or used in the manufacture or sale of apparatus without permission.

401-08952-000
SHEET 1 OF 10

190-08952 TABULATION

REV	DES	DATE	BY
		-009	A
U24	146-00229-013		
U37	146-00191-002		
U51	146-00192-001		
ST5	ENABLE		
ST4	ENABLE		

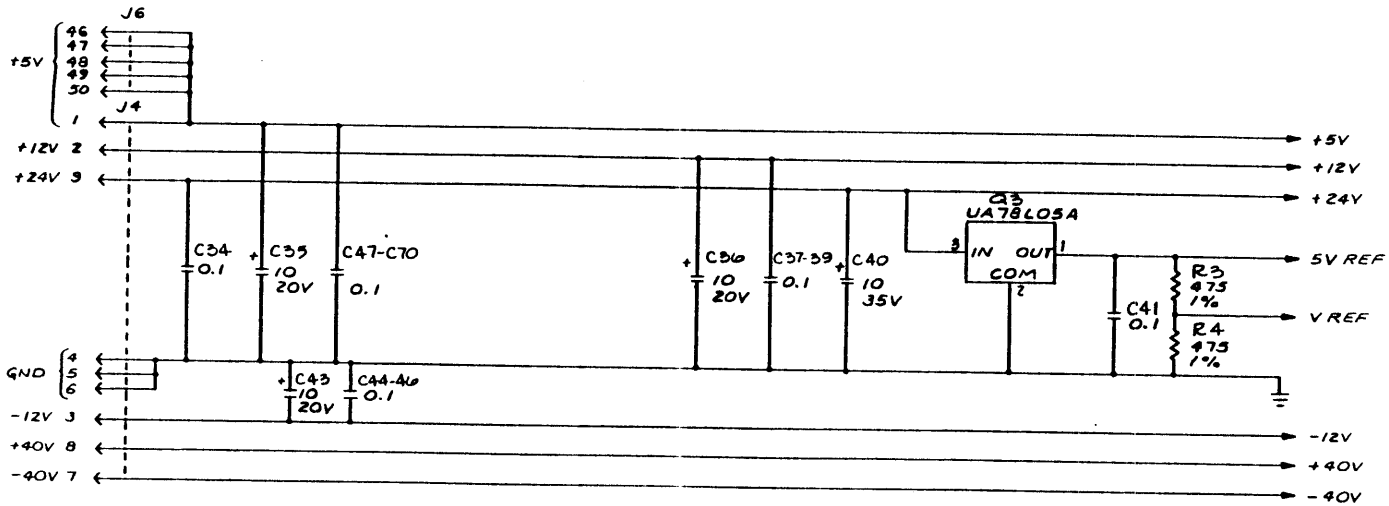

- △ COMPONENT LOCATIONS PROVIDED ON THE PCB, BUT ARE NOT USED.
- △ CIRCUIT SHOWN USING 27276 IC TYPES 27128 AND 2764 ARE INTERCHANGEABLE WITH 27256, WITH THE EXCEPTION OF FUNCTIONS IN THE CONTROL BLOCK. SEE DIAGRAMS TO THE RIGHT.

5 ALL DIODES ARE 1N914.

△ PI CONNECTOR PIN AND FUNCTION SHALL BE COORDINATED WITH THE MOTHER BOARD (401-01106-001) FOR PINS NOT SHOWN ON DRAWING.

- 3. ALL CAPACITOR VALUES ARE IN MICROFARADS.
- 2. ALL RESISTOR VALUES ARE IN OHMS ±5%, 1/4 W
- 1. X INDICATES NO CONNECTION.

NOTES: UNLESS OTHERWISE SPECIFIED.

REV STATUS	REV	L	L	A	A	C	F	A	B	A	B
OF SHEETS	SHEET	1	2	3	4	5	6	7	8	9	10

REF DES	TYPE	QTY	5V
U26, 27, 28	74LS00	7	14
U19, 57	74LS04	7	14
U7	74LS08	7	14
U18	74LS14	7	14
U45, 52	74LS57	7	14
U33, 22	74LS14	7	14
U4	7492	10	2
U63	74LS107	7	14
U19	74LS137	7	14
U44	74LS138	8	16
U50	74LS155	8	16
U12, 22, 40, 41, 63	74LS244	10	20
U29	74LS243	10	20
U3	74LS04	7	14

REF DES	TYPE	QTY	5V
U64	74LS260	7	14
U1, 5, 6	74LS367	8	16
U19	74LS373	10	20
U46	74LS393	7	14
U38, 39, 46, 67	74LS070	8	16
U24	74NCT04	7	14
U8	74NCT04	7	14
U9, 16	MC14954B	7	14
U14	8031	-	20
U30	B254-?	17	24
U2, 13, 23, 34	B255A	7	20
U38, 39, 60	HT-201	5	-
U51	1608	10	20
U37	1626	10	20
U49, 53	74	7	14
U43, 50, 69	74	10	20

REF DES	LAST USED	NOT USED
C78		
CE30	CA 4, 3, 20	
C10		
R169	R12, 16	
ST4		
ST5		
U73	U70	
LB		

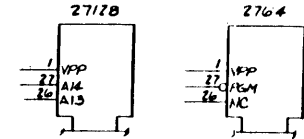

9600 Drive Electronics
Type 8952
Schematic Diagram

These drawings and specifications are the property of Kennedy Company and shall not be reproduced, or copied, or used in the sale for the manufacture or sale of apparatus without permission.

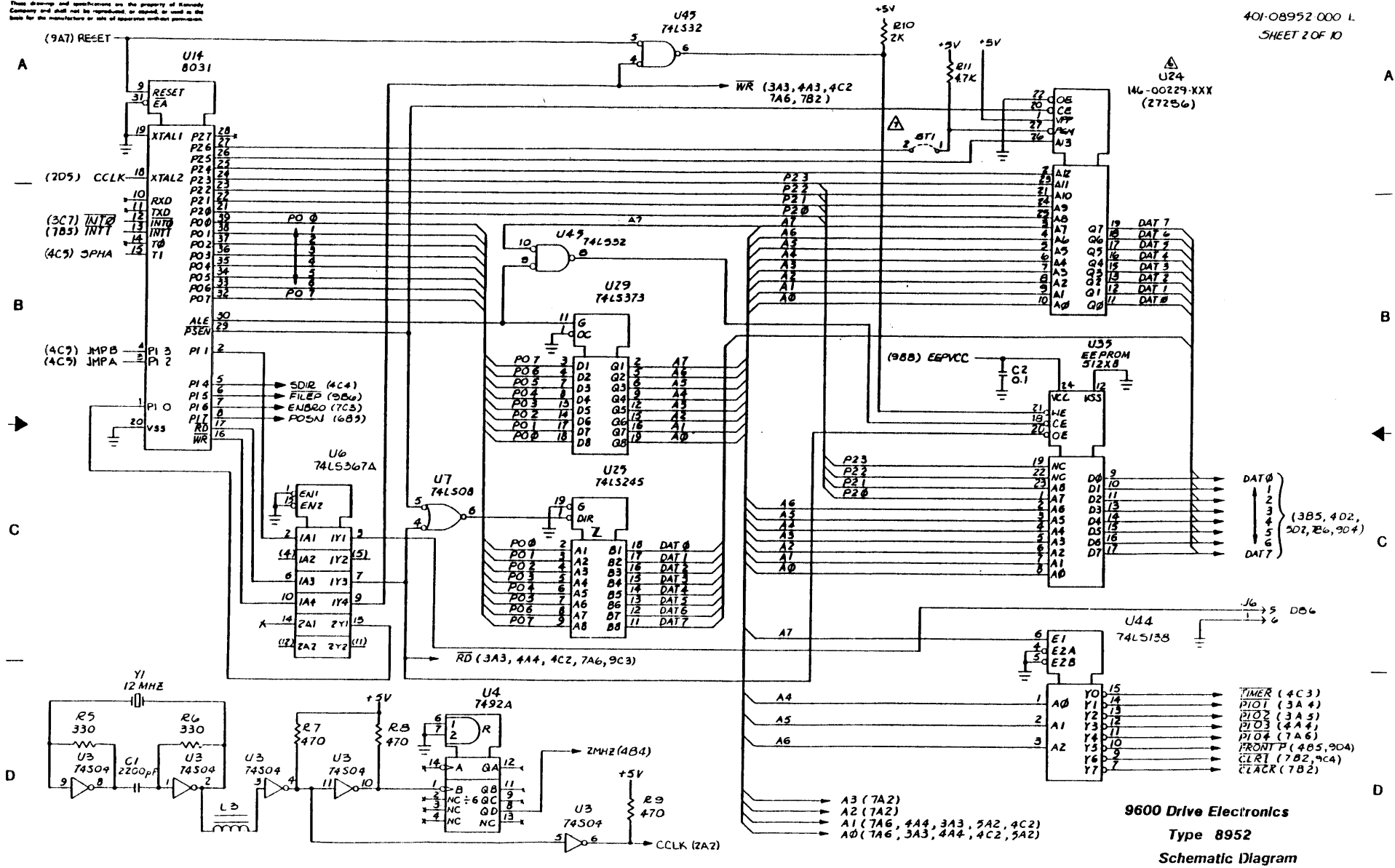

9600 Drive Electronics
Type 8952
Schematic Diagram

These drawings and specifications are the property of Kennedy Company and shall not be reproduced, or copied, or used in the same for the manufacture or sale of apparatus without permission.

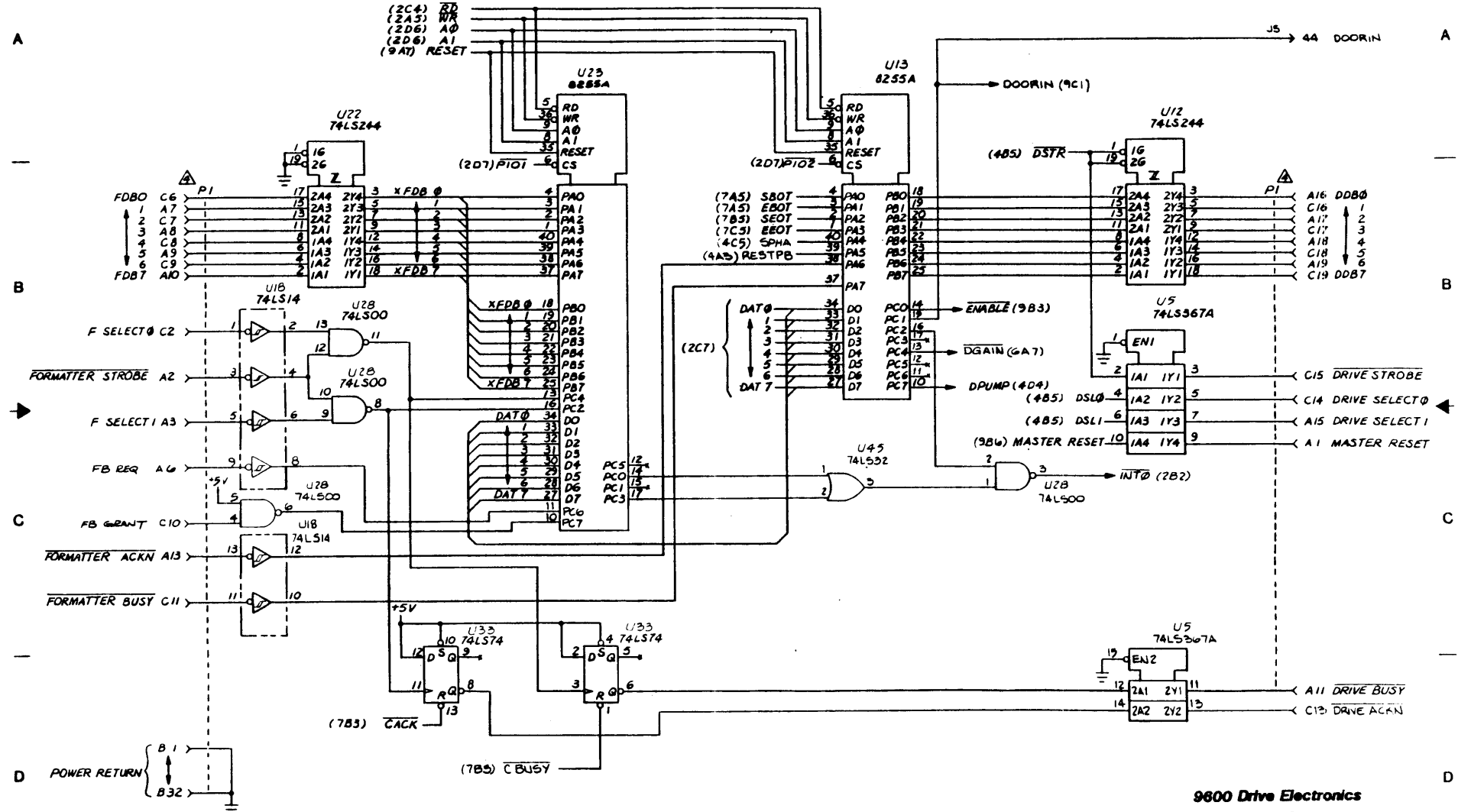

9600 Drive Electronics
Type 8952
Schematic Diagram

These drawings and specifications are the property of Kennedy Company and shall not be reproduced, or applied in use in the laboratory or manufacture or sale of apparatus without permission.

401-08952-000A
SHEET 4 of 10

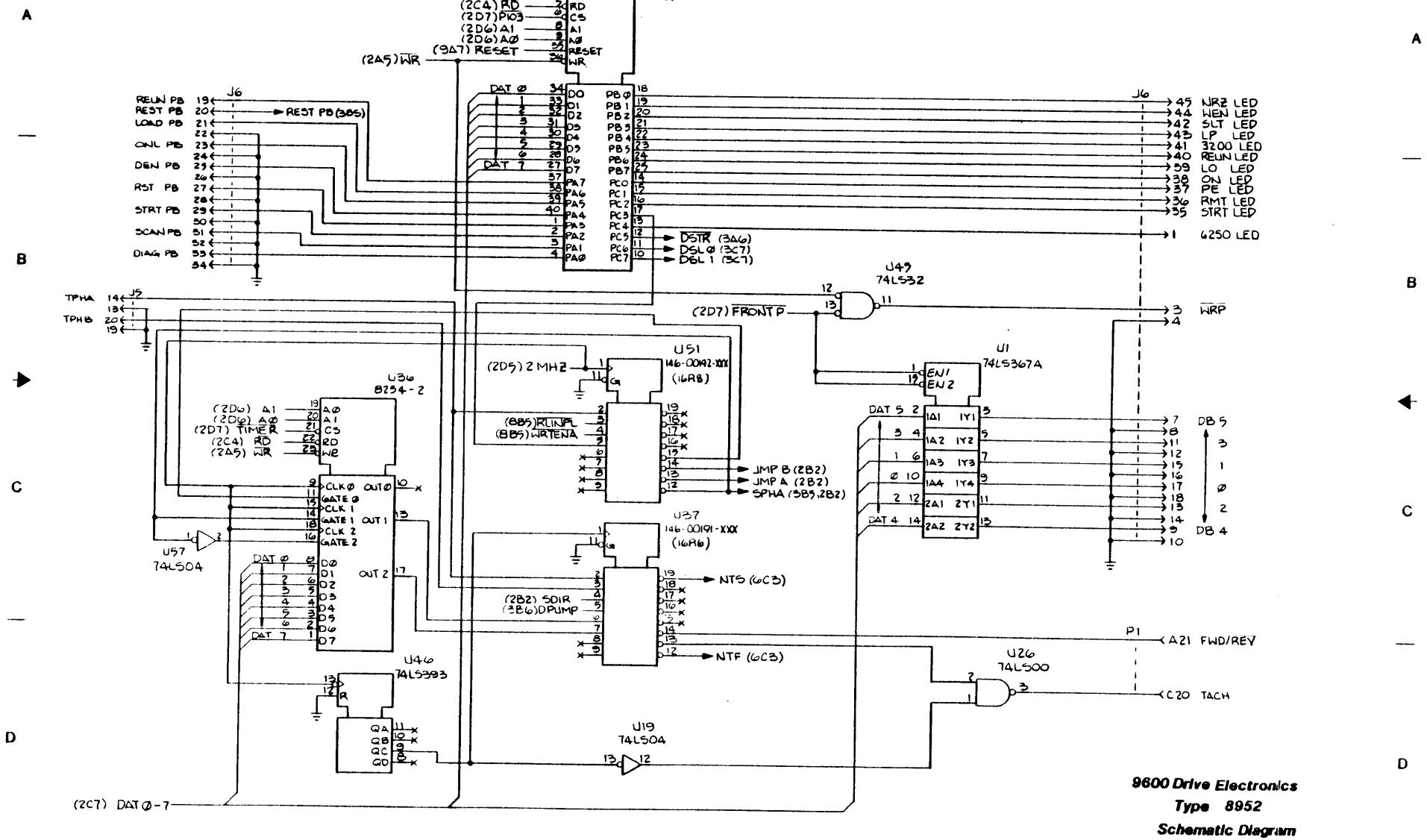

9600 Drive Electronics
Type 8952
Schematic Diagram

This drawing and specifications are the property of Kennedy Company and shall not be reproduced, copied or used in any form for the manufacture or sale of spurious without permission.

401-C8972-000 C
SHEET 5 OF 10

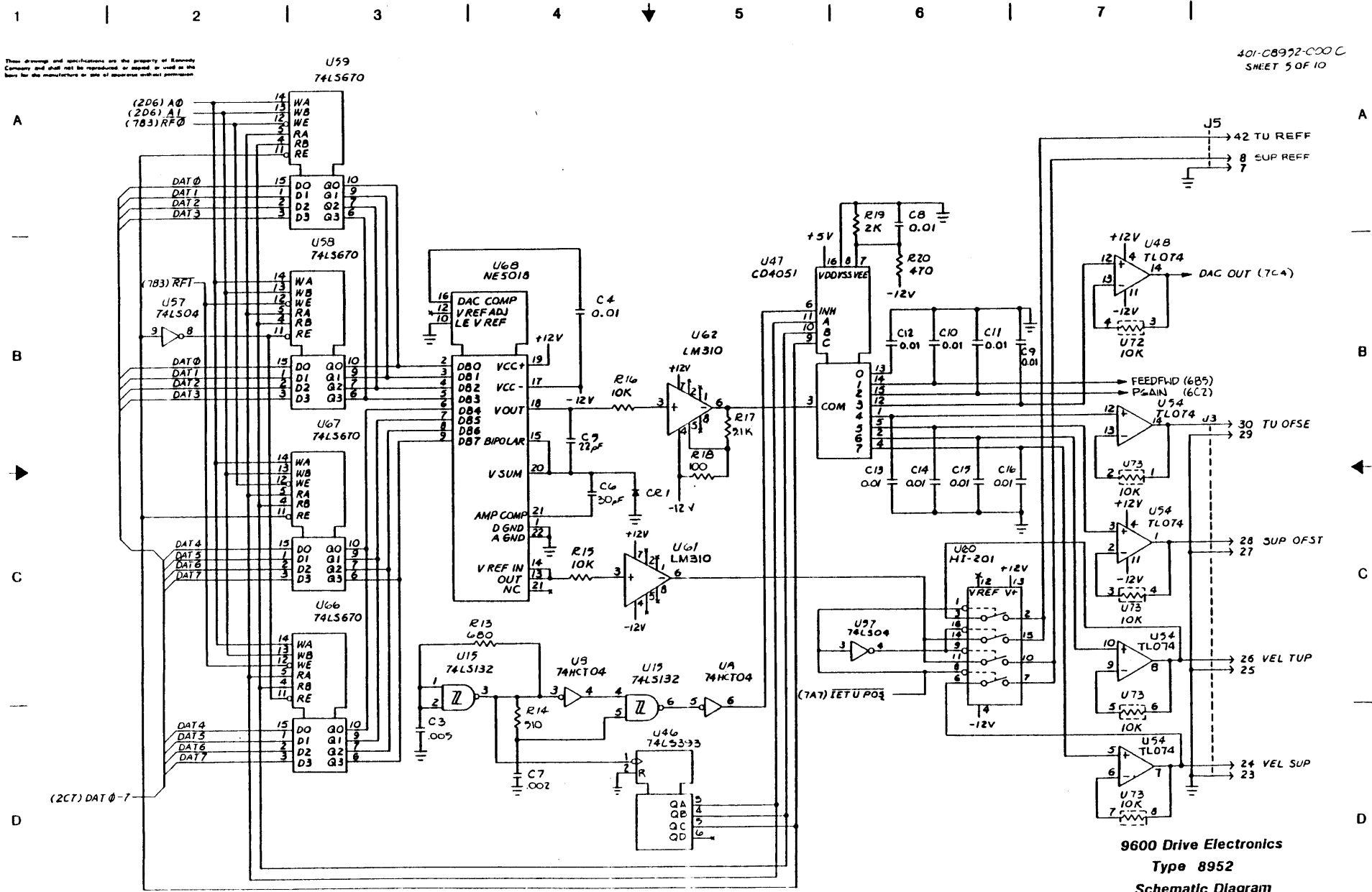

9600 Drive Electronics
Type 8952
Schematic Diagram

1 | 2 | 3 | 4 | 5 | 6 | 7

This drawing and specifications are the property of Kennedy Company and shall not be reproduced, in whole or in part, in any form for the manufacture or sale of apparatus without permission.

401-08952-000F
SHEET 6 OF 10

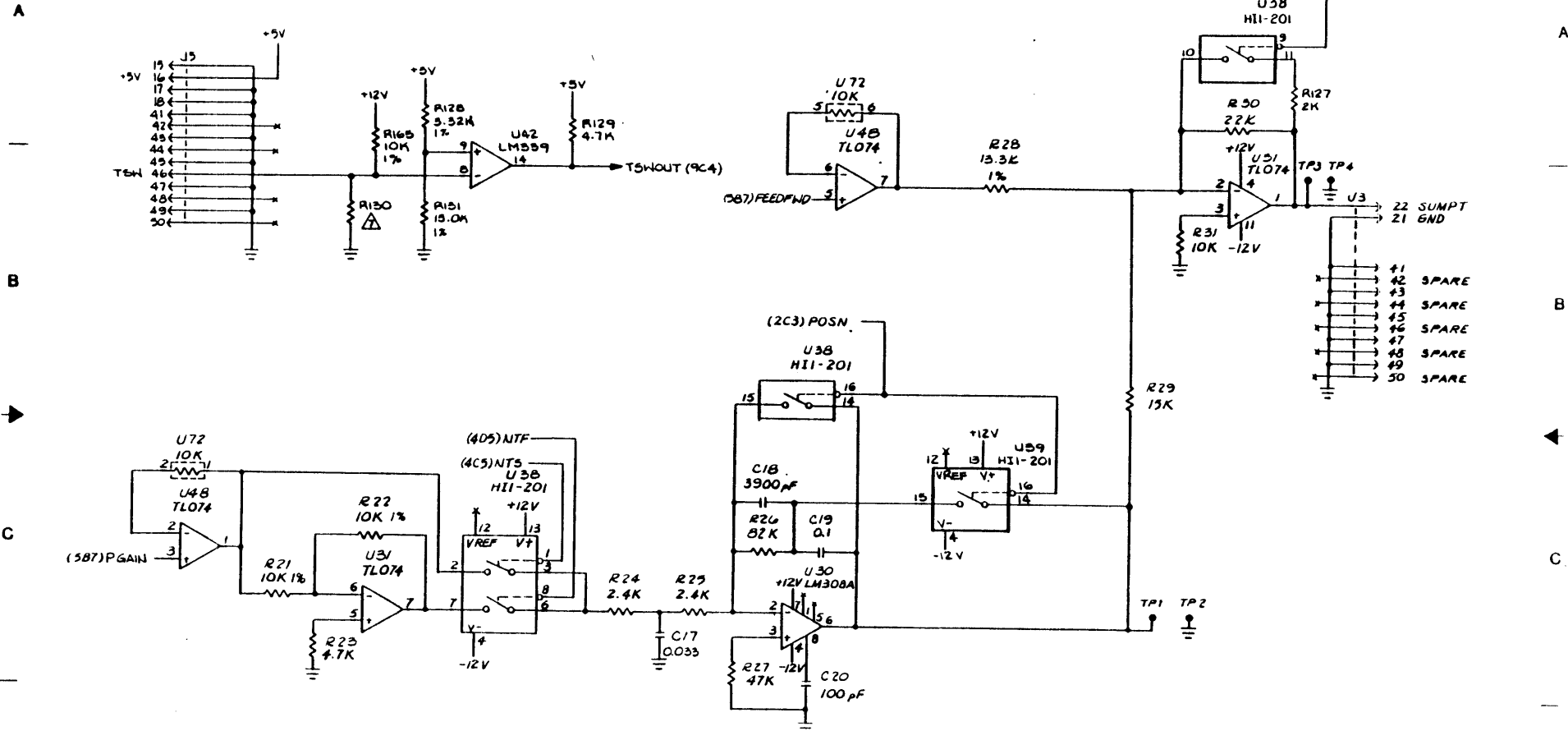

D

1 | 2 | 3 | 4 | 5 | 6 | 7 | 8

9600 Drive Electronics
Type 8952
Schematic Diagram

These drawings and specifications are the property of Kennedy Company and shall not be reproduced, in whole or in part, for the manufacture or use of equipment without permission.

401-08952.000 A
SHEET 7 OF 10

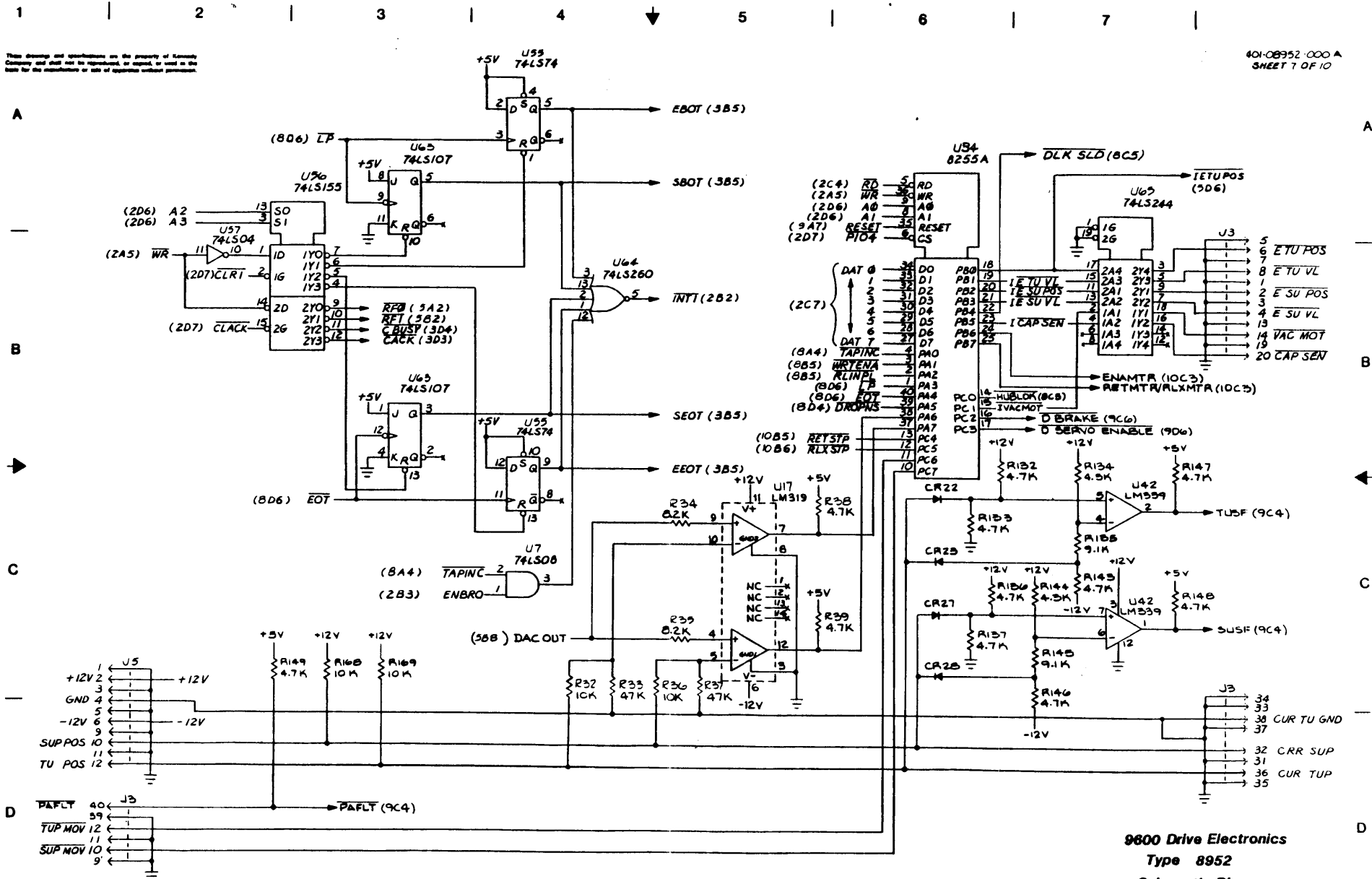

9800 Drive Electronics
Type 8952
Schematic Diagram

These drawings and specifications are the property of Kennedy Company and shall not be reproduced, or copied, or used in the form for the manufacture or sale of apparatus without permission.

401-08952-000 B
SHEET 8 OF 10

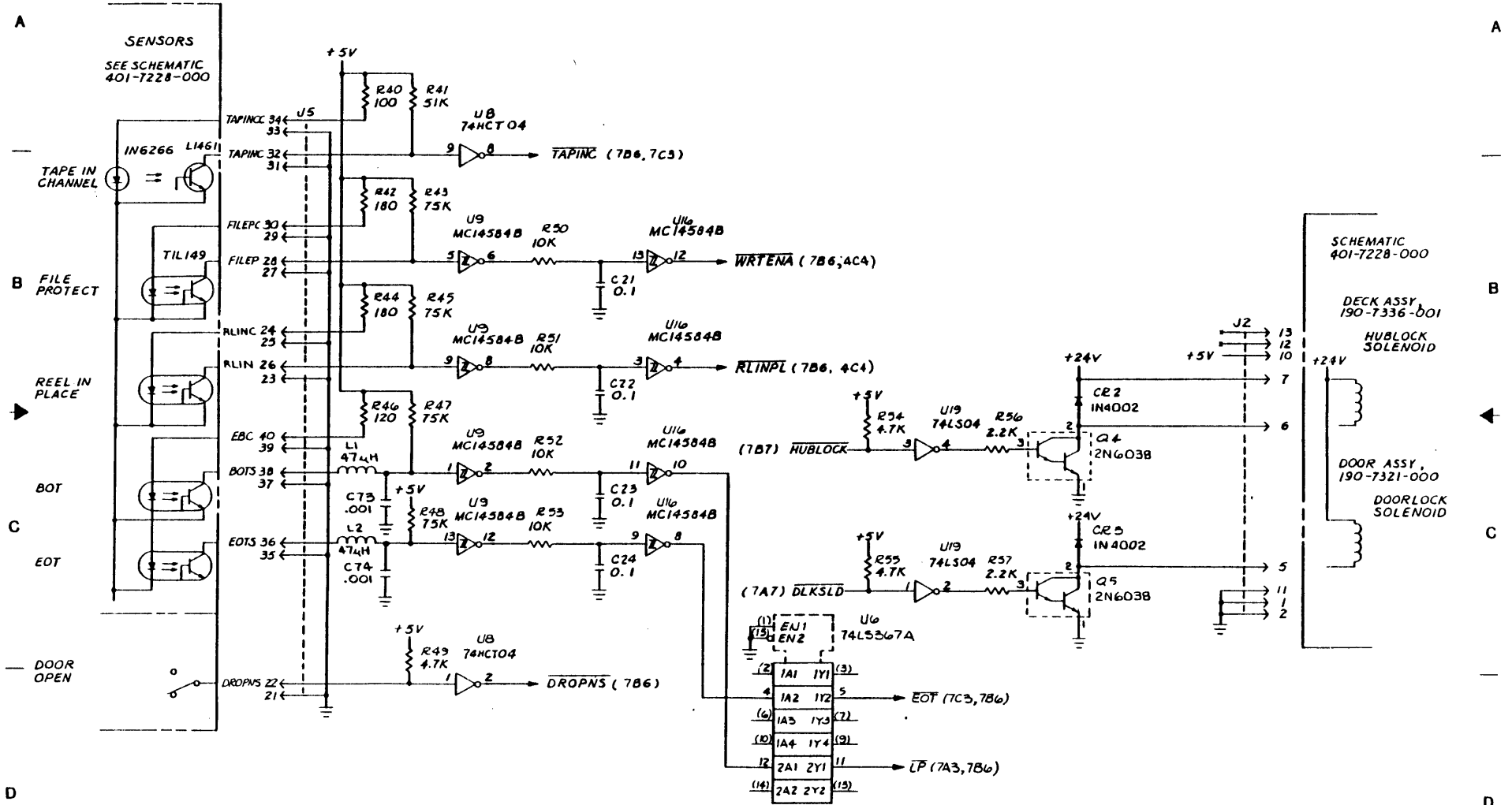

9600 Drive Electronics
Type 8952
Schematic Diagram

These drawings and specifications are the property of Kennedy Company and shall not be reproduced or copied in whole or in part for the manufacture or sale of apparatus without permission.

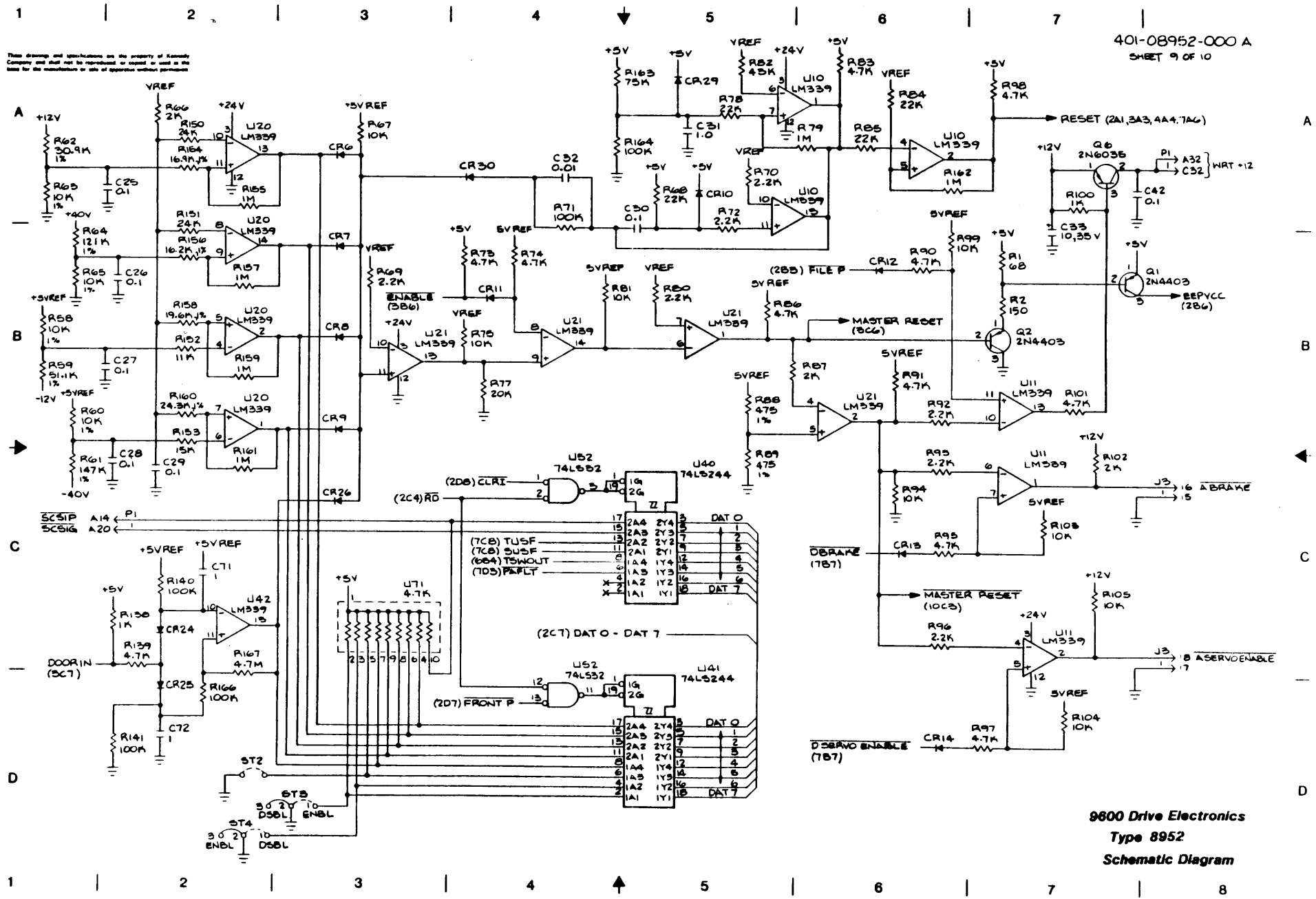

9800 Drive Electronics
Type 8952
Schematic Diagram

These drawings and specifications are the property of Kennedy Company and shall not be reproduced, stored, or used in the base for the manufacture or sale of apparatus without permission.

A

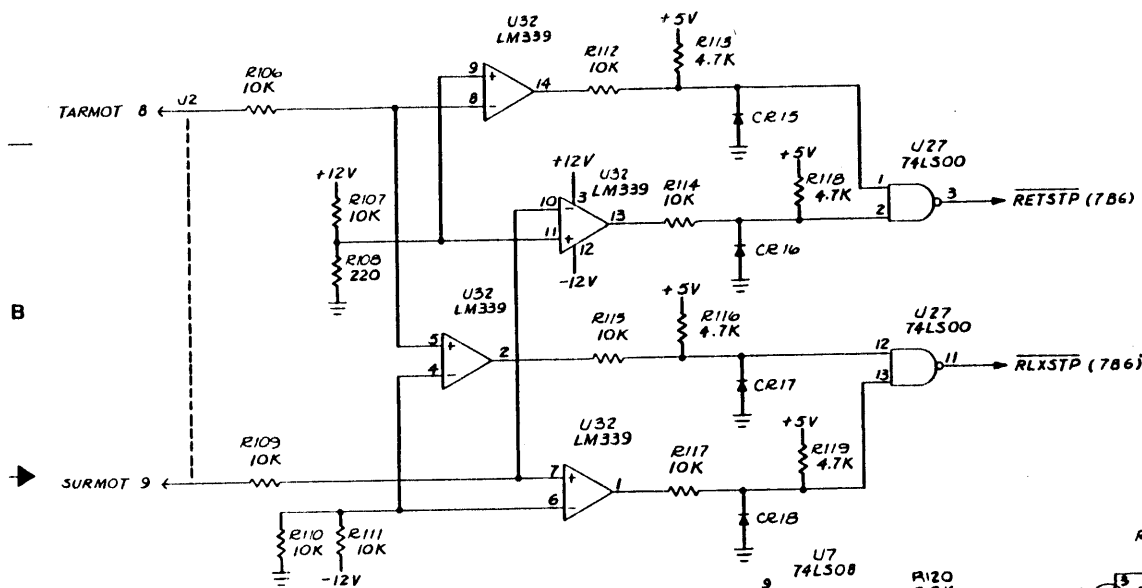

C

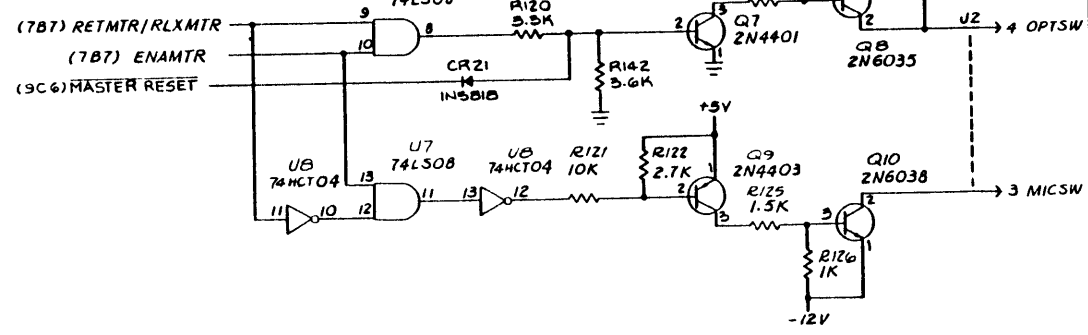

D

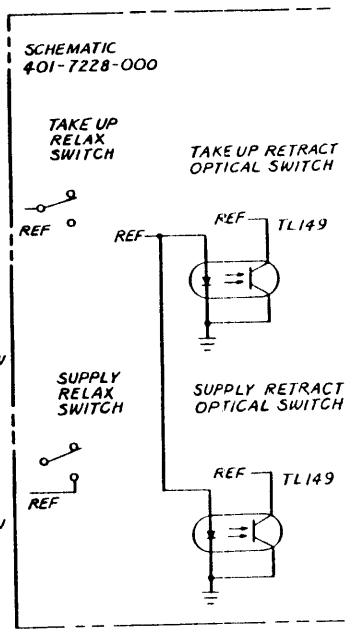

9600 Drive Electronics
Type 8952
Schematic Diagram

These drawings and specifications are the property of Remcom. Contents and shall not be reproduced, or stored in a retrieval system, without the prior written permission of Remcom.

190-08951 TABULATION

REF DES	DRSH NO REV	
	-014	A
U21	46-0211-013	
W1	USED	
W2		
W3		
W4	USED	

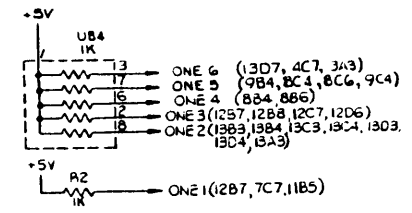
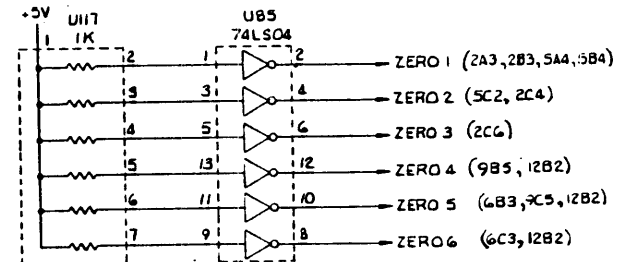
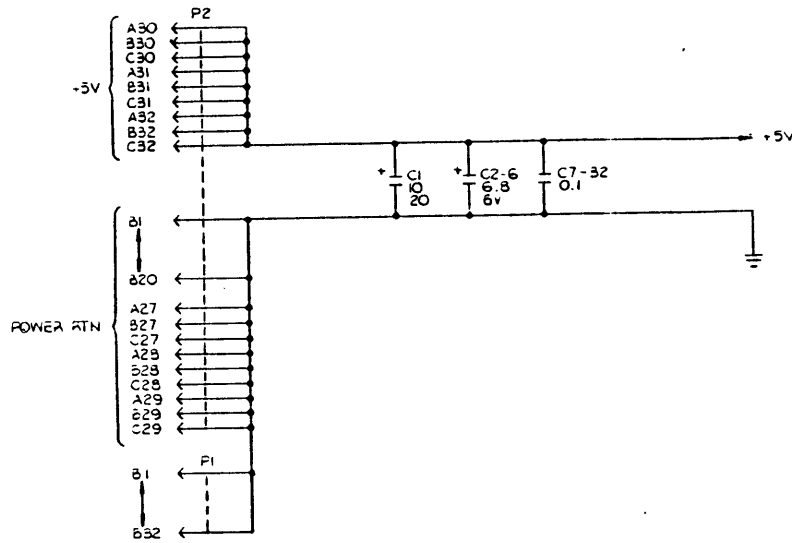

REF DES	TYPE	QND	+5V
U14, U15	74LS164	10	20
U15, 55, 67	74LS164	10	20
U57, 60, 69, 71	74LS00	7	14
U114	74LS02	7	14
U17, 30, 25, 85	74LS04	7	14
U14	74LS08	7	14
U1A, 31, 86	74LS08	7	14
U42	74LS10	7	14
U9	74LS11	7	14
U6, 24, 27, 42	74LS138	8	16
U4 - 38	74LS138	8	16
U50	74LS139	8	16
U56, 68	74LS161	8	16
U118, 29, 41	74LS169	8	16
U2, 66, 78, 74	74LS169	8	16
U57	74LS20	7	14
U16, 17, 21, 84	74LS240	10	20
83	74LS240	10	20
U92	74F04	7	14

REF DES	TYPE	QND	+5V
U40, 46, 53, 55	74LS244	10	20
U2, 7, 10, 11, 13	74LS244	10	20
89, 90, 107	74LS245	10	20
U51, 92	74LS245	10	20
U55	7425	7	14
U70, 58	248	7	14
U80, 83, 248	74LS275	8	16
U47, 57, 95	74LS32	7	14
U108	74LS373	10	20
U26, 39, 63, 77	74LS374	10	20
76, 78, 79, 99	74LS374	10	20
U1, 102, 109	7438	7	14
U10, 111	7438	7	14
U33, 22, 15, 14	74LS562	10	20
U100	74LS562	10	20
U43, 44, 163	74LS74	7	14
64, 87, 94, 96	74LS74	7	14
103, 105, 106	74LS74	7	14
U13	74LS85	8	16
U23	74LS85	8	16
U1	74LS86	7	14
U28	8051	40	
U71	74LS14	7	14
U116	74LS14	7	14
C67, 85	21884	19	128

REF DES	LAST USED	NOT USED
TP2		
J2		
B2		
W4		
U117		
U10		
C37	C34, 35	
CA1		
Y2	Y1	

△ COMPONENT LOCATIONS PROVIDED ON THE PCB BUT NOT USED

9. P1, P2 CONNECTOR PIN AND FUNCTION SHALL BE COORDINATED WITH THE MOTHER BOARD (401-7108-000) FOR PINS NOT SHOWN ON THIS DRAWING.

2. RESISTORS ARE IN OHMS 5%, 1/4 W.
1. CAPACITORS ARE IN MICROFARADS 18% 50V

NOTES: UNLESS OTHERWISE SPECIFIED

REV STATUS OF SHEETS	REV SHEET	REV												
		R	R	A	A	A	A	A	A	A	A	A	A	A
		1	2	3	4	5	6	7	8	9	10	11	12	13

FORMATTER
TYPE 8951
SCHEMATIC DIAGRAM

This drawing and specifications are the property of Kennedy Company and will not be reproduced or used in any form for any other project without the written consent of Kennedy Company.

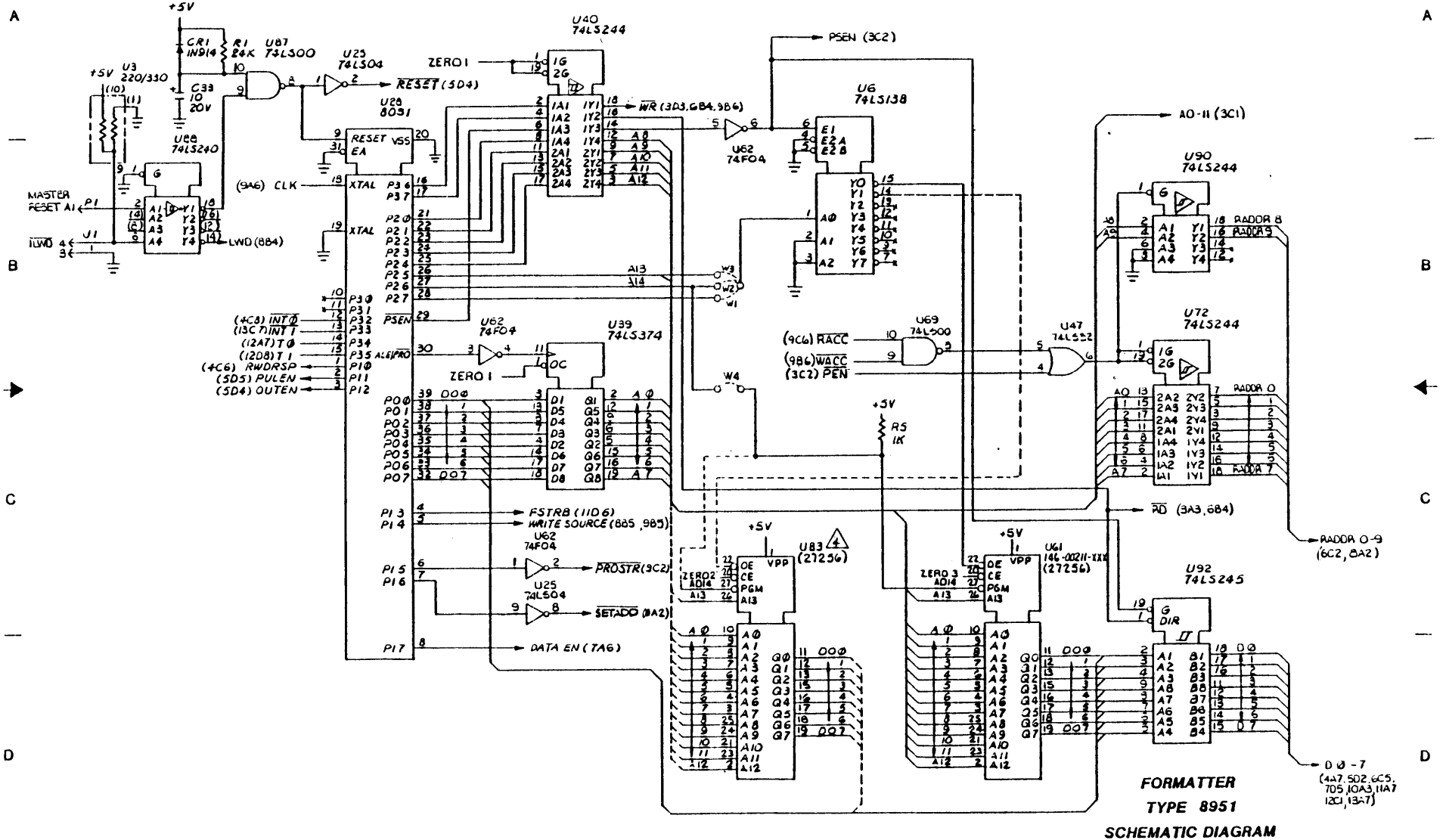

1 | 2 | 3 | 4 | 5 | 6 | 7

These drawings and specifications are the property of Kennedy Company and shall not be reproduced or copied or used in the same for the manufacture or sale of apparatus without permission.

401-08951-001-A
SHEET 3 OF 13

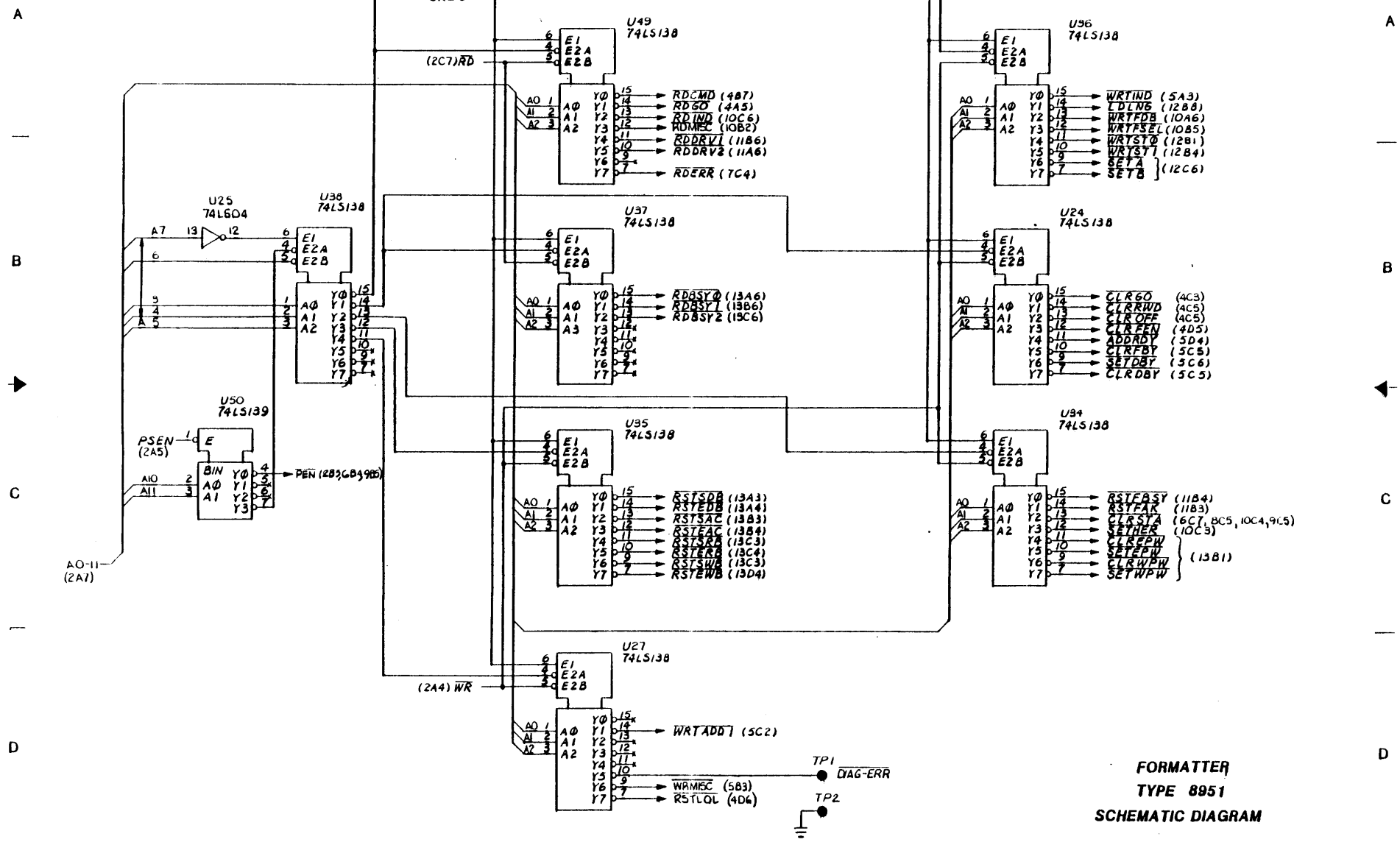

**FORMATTER
TYPE 8951
SCHEMATIC DIAGRAM**

1 | 2 | 3 | 4 | 5 | 6 | 7 | 8

These drawings and specifications are the property of Bendisy Company and shall not be reproduced or copied in whole or in part for the manufacture in any of approved without permission

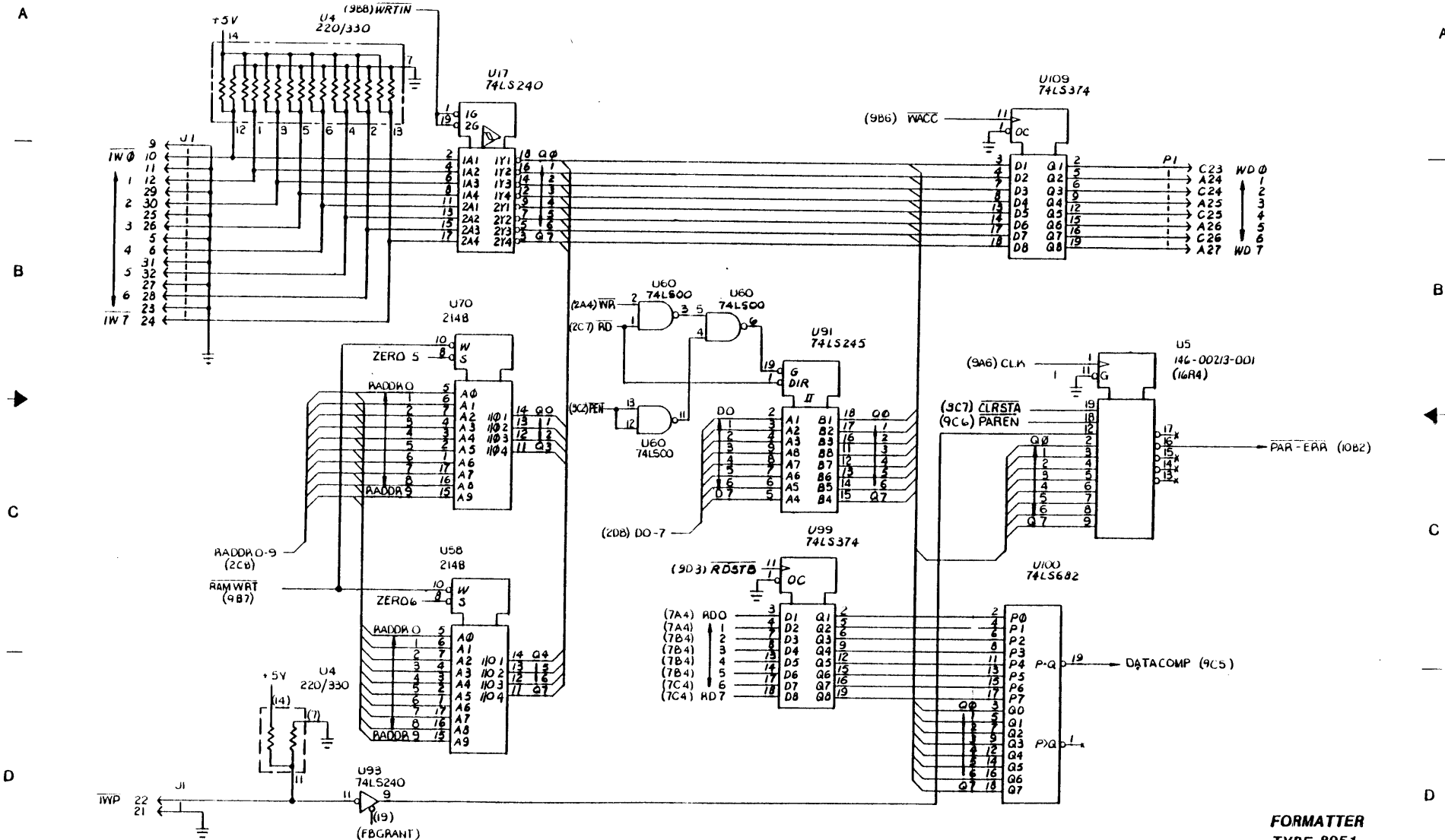

**FORMATTER
TYPE 8951
SCHEMATIC DIAGRAM**

These drawings and specifications are the property of Kennedy Company and shall not be reproduced or copied or used in any way for the manufacture or sale of apparatus without permission.

401-0895-000 A
SHEET 7 OF 13

A

B

C

D

A

B

C

D

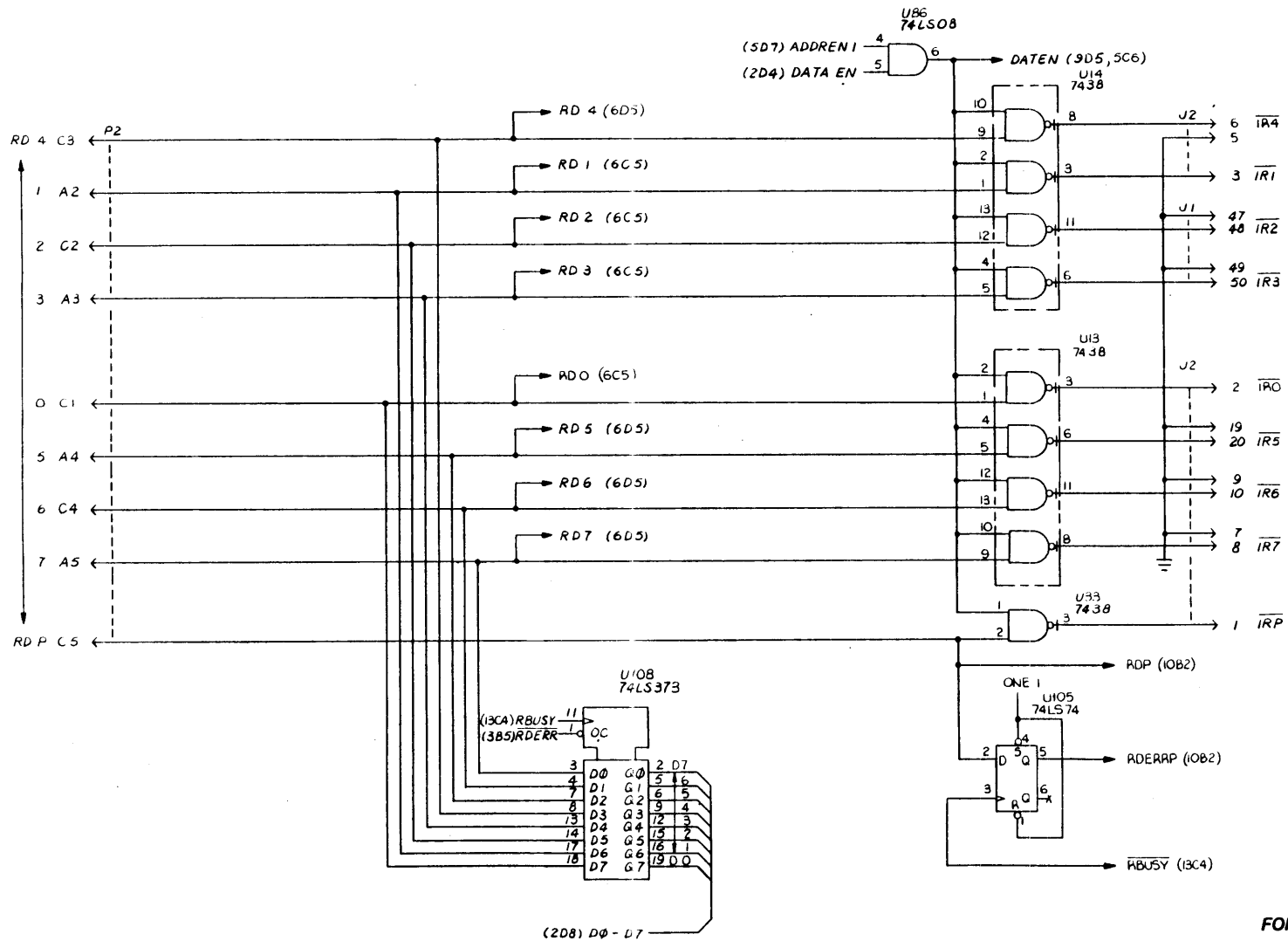

**FORMATTER
TYPE 8951
SCHEMATIC DIAGRAM**

These drawings and specifications are the property of Kennedy Company and shall not be reproduced or copied in any form for the manufacture or sale of apparatus without permission.

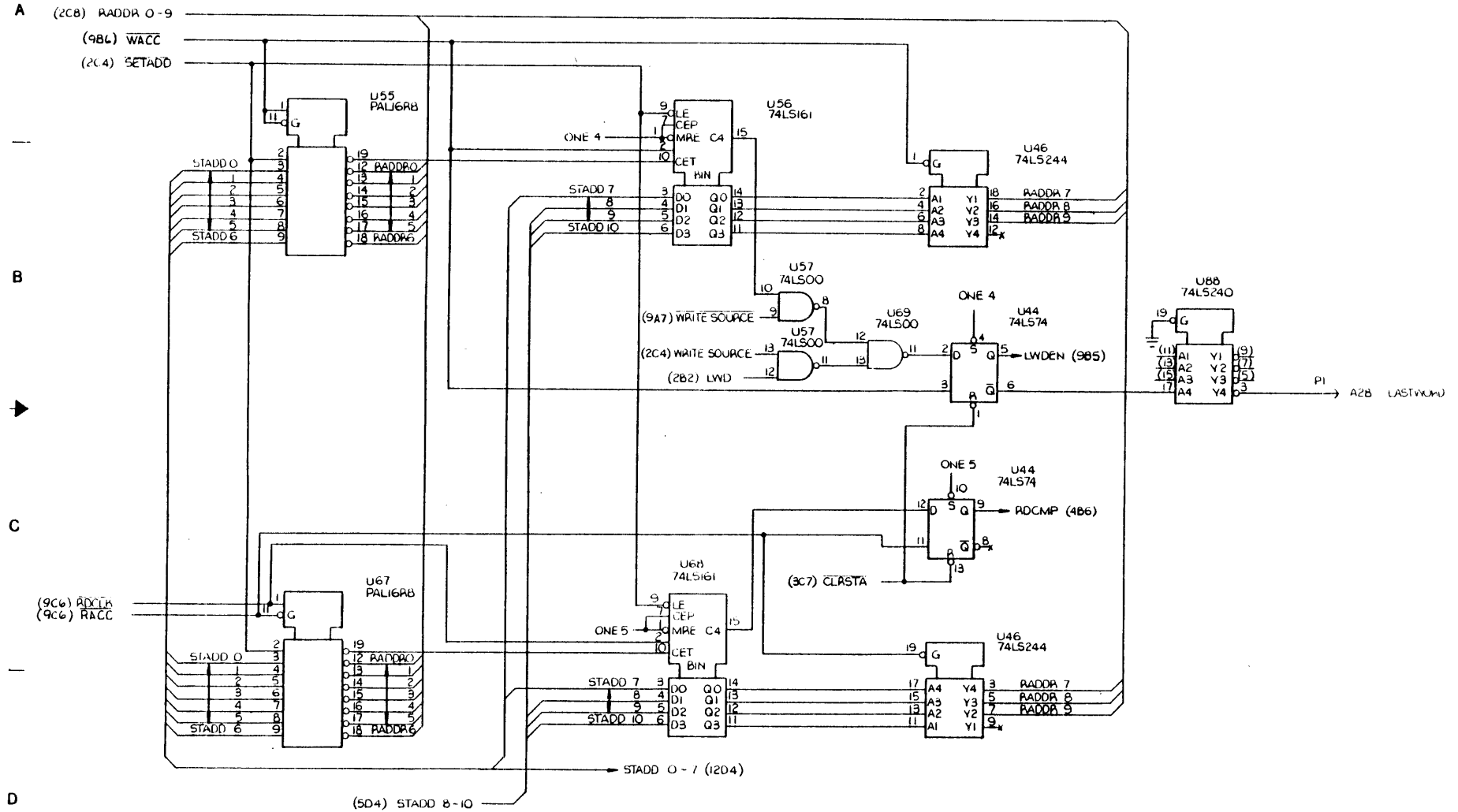

FORMATTER
TYPE 8951
SCHEMATIC DIAGRAM

These drawings and specifications are the property of Kennedy Company and shall not be reproduced or copied, or used in the form for the manufacture or sale of apparatus without permission.

401-08951-000 A
SHEET 9 OF 13

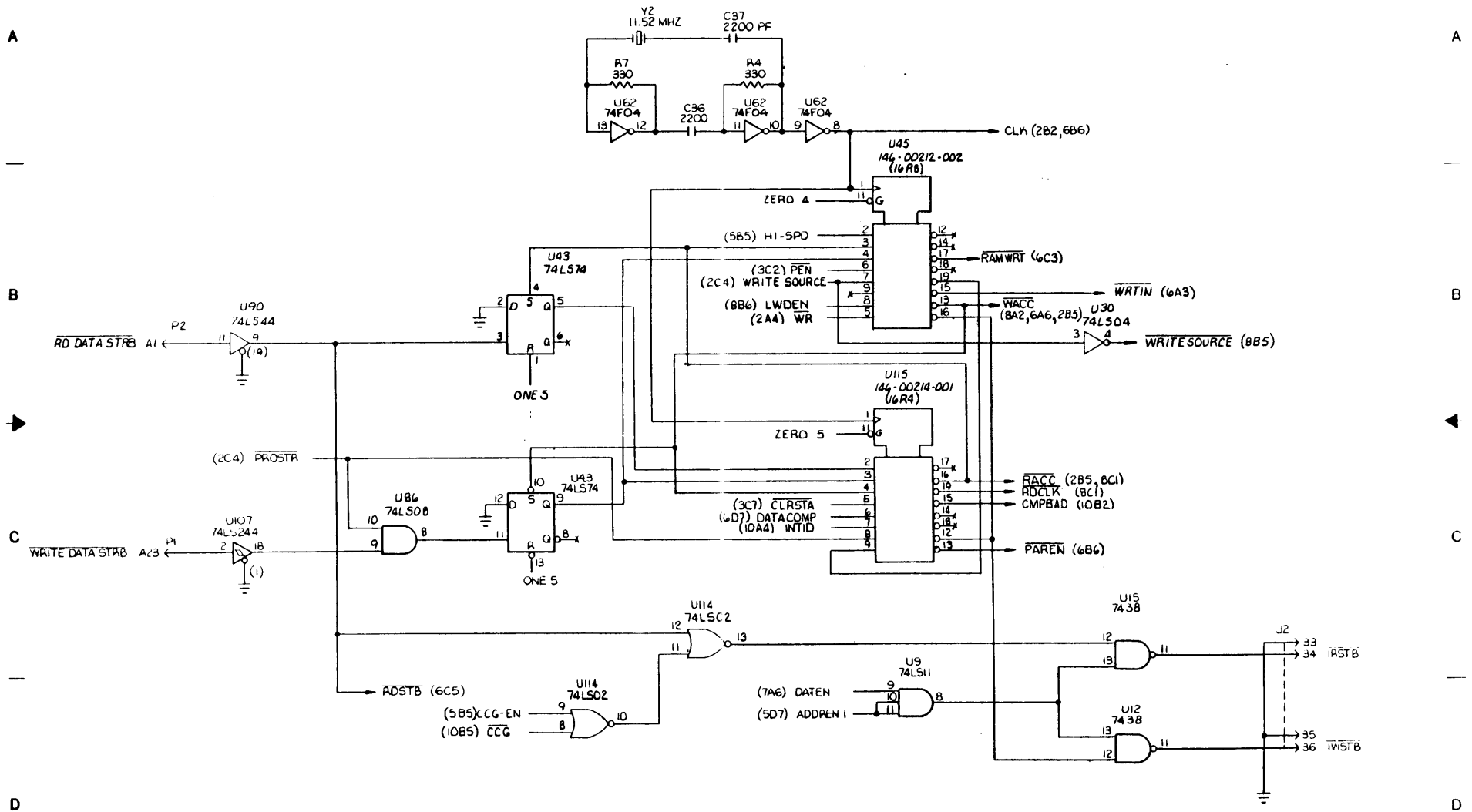

**FORMATTER
TYPE 8951
SCHEMATIC DIAGRAM**

This drawing and specifications are the property of Honeywell Company and shall not be reproduced or copied in whole or in part for the manufacture or sale of spares without permission.

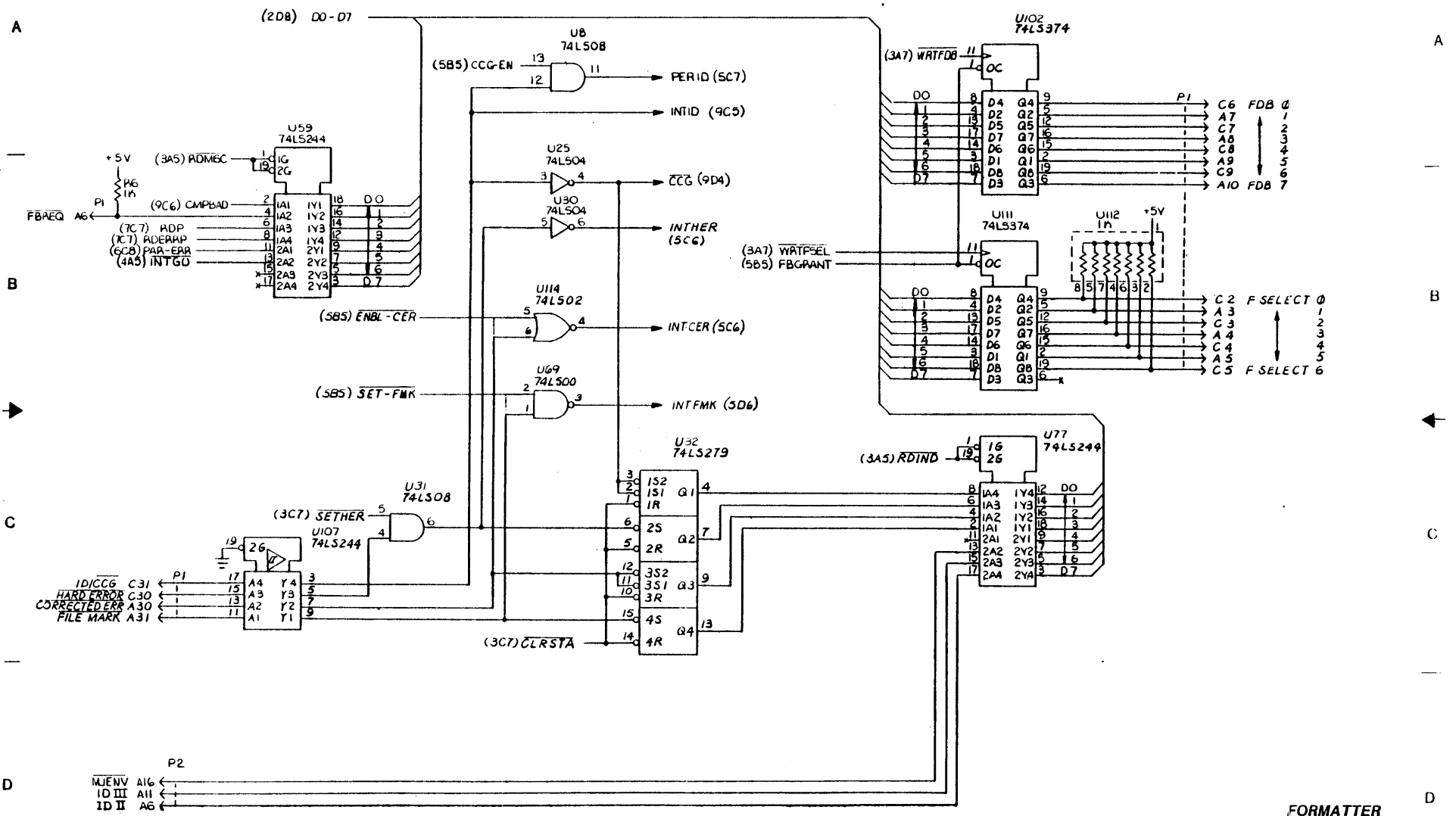

FORMATTER
TYPE 8951
SCHEMATIC DIAGRAM

These drawings and specifications are the property of Kennedy Company and shall not be reproduced or copied in whole or in part for the manufacture or sale of apparatus without permission.

401-08951-000 A
SHEET 11 OF 15

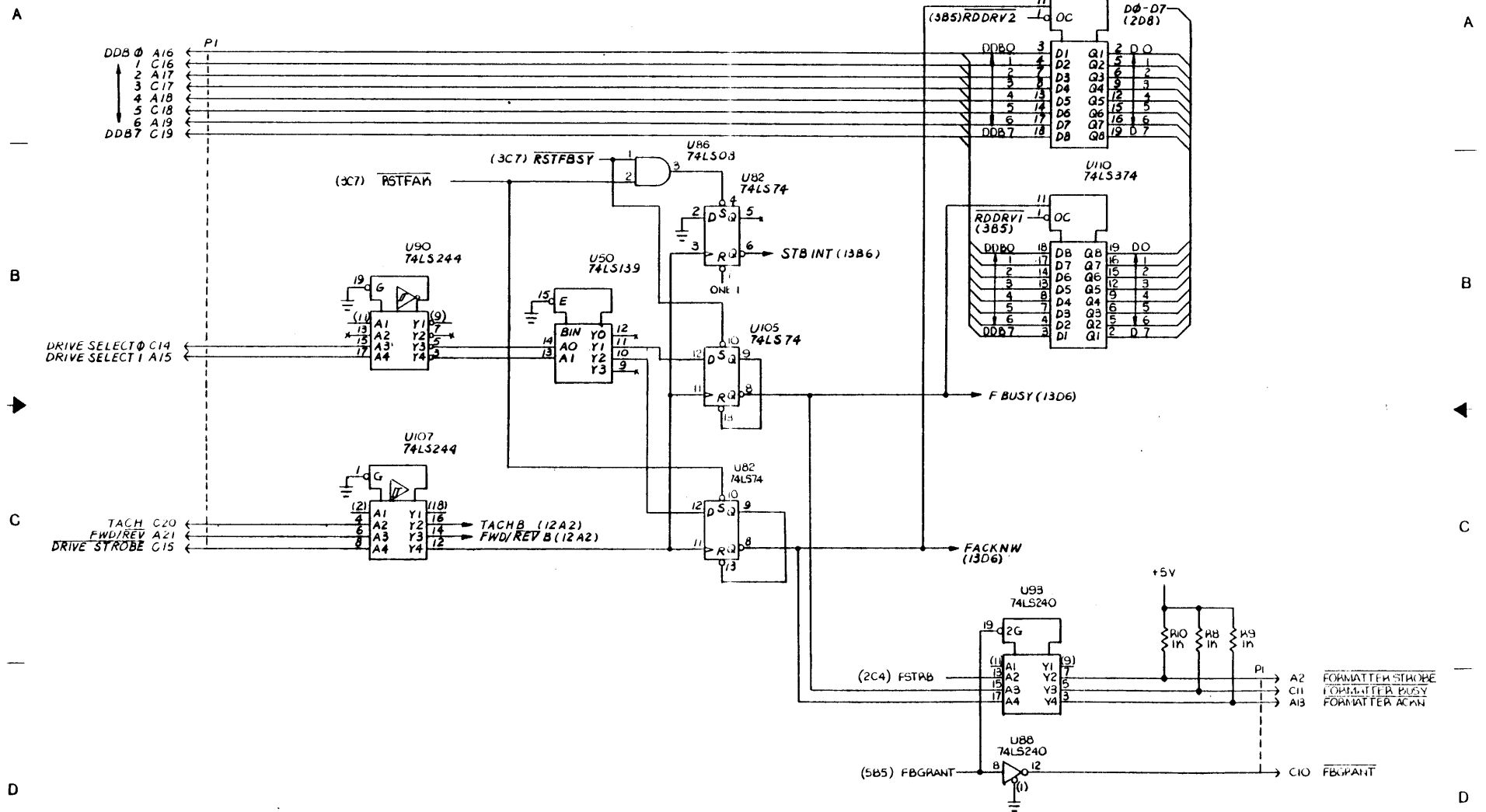

**FORMATTER
TYPE 8951
SCHEMATIC DIAGRAM**

11-1

1 | 2 | 3 | 4 | 5 | 6 | 7 | 8

These drawings and specifications are the property of Kennedy Company and shall not be reproduced or copied or used as the base for the manufacture or sale of apparatus without permission.

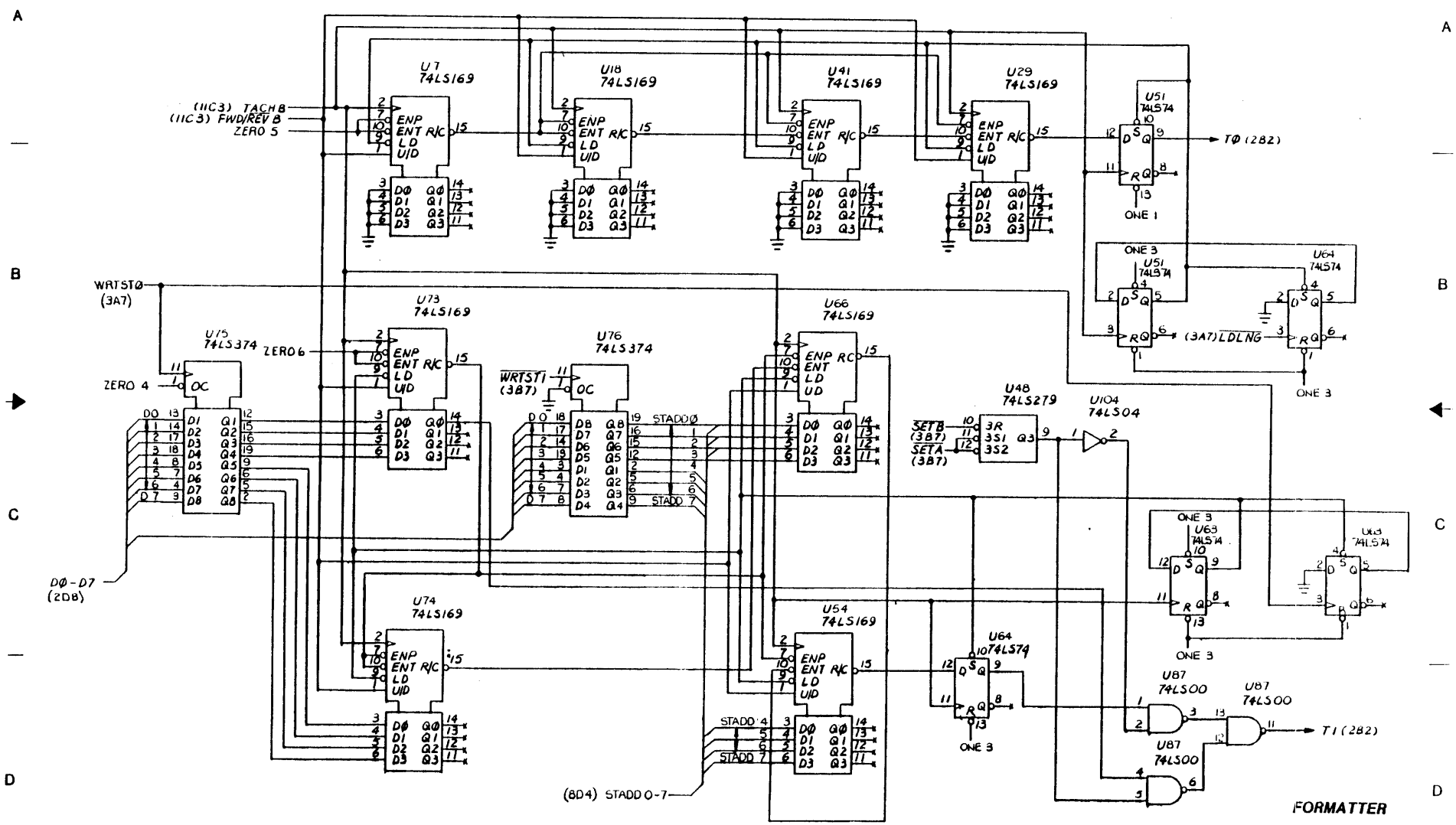

FORMATTER
TYPE 8951
SCHEMATIC DIAGRAM

1 | 2 | 3 | 4 | 5 | 6 | 7 | 8

These drawings and specifications are the property of Kennedy Company and shall not be reproduced or used in any form for the manufacture or sale of apparatus without permission.

190-09060-TABULATION

REF DES	DASH NO		REV
	-011	A	
U12	146-00222-001		
U30	146-00224-001		
U33	146-00218-001		
U34	146-00219-001		
U44	146-00221-001		
U45	146-00220-001		
U79	146-00215-002		
U80	146-00223-002		
U48	146-00216-001		
U74	146-00217-001		
U40	146-00240-002		
U51	146-00240-002		
U90	146-00240-002		
W1	USED		
W2			
W3	USED		
W4			
W5	USED		

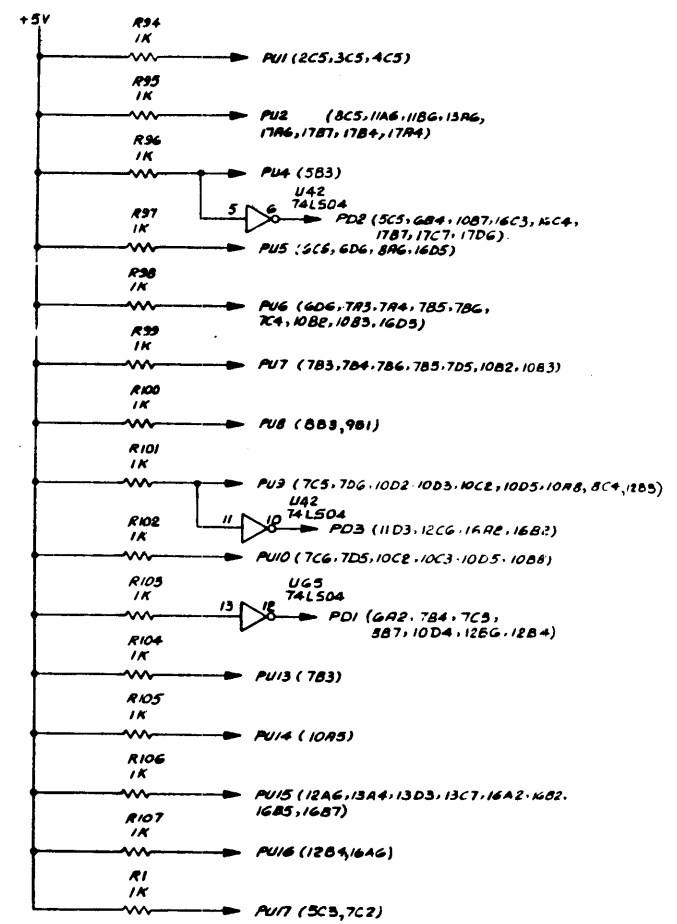
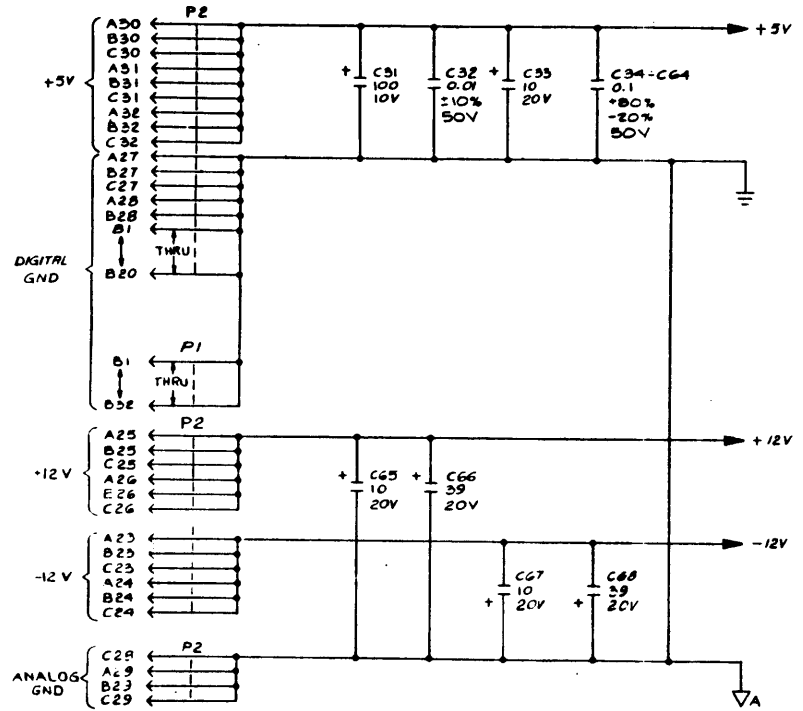

- △ COMPONENT LOCATION PROVIDED ON THE PCB BUT NOT USED.
 - 5. ALL TRANSISTORS ARE 2N4403
 - △ SIGNAL OUTPUTS (DATA AND SIGLOS (NUMBERED 1-9)) CORRESPOND TO PHYSICAL TRACK LOCATIONS ON THE TAPE. THESE OUTPUTS ARE CONNECTED TO THE DATA PATH SIGNAL LINES TO AND FROM (NUMBERED (O-P) PER THE EDDIC CONVENTION.
 - 5. ALL DIODES ARE IN34.
 - 2. RESISTORS ARE IN OHMS 5% 1/4 W.
 - 1. CAPACITORS ARE IN MICROFARADS 10% 50V
- NOTES: UNLESS OTHERWISE SPECIFIED

REF DES	TYPE	GND	+3V	REF DES	TYPE	GND	+5V	REF DES	TYPE	GND	+5V
U17,18,19	74265	8	16	U66,75,84	74LS245	10	20	LAST USED	NOT USED		
U43,53,61,62	MS223	10	20	U23,64,73	74LS257	8	16	C77			
U50	74LS00	7	14	U32,53	74LS374	10	20	CR25			
U76	74LS02	7	14	U16,57	74LS393	7	14	L1			
U42,63,77	74LS04	7	14	U7	74F00	7	14	Q43			
U49,68	74LS08	7	14	U5	74F02	7	14	R117	RS3		
U56	74LS10	7	14	U6,46,22	74F04	7	14	TP20			
U20	74LS12	7	14	U3-5,29,32,31,30A	74F74	7	14	U9			
U36,63,83	74LS32	7	14	U8	74F163	8	16	U5			
U10,26,27,38,59,60,71	74LS74	7	14	U47	74F253	8	16	U5			
U74	74LS125	7	14	U35	74F257	8	16	YE			
U24	74LS163	8	16	U30,33,34,44,45,79,80	74F259	8	16				
U31,41	74LS164	7	14	U7B	16468-2	10	20				
U70	74LS175	8	16	U40,42,51,50	16488-2	10	20				
U69	74LS240	10	20	U1E	16488-PMS	10	20				
U54,52,83	74LS244	10	20	U4	74NC139	8	16				
87,88,89	74LS244	10	20	U8	74NC200	8	16				
				U9	74NC200	7	14				
				U86	74LS244	7	14				

REV STATUS OF SHEETS	REV	A	L	E	E	A	E	E	J	E	E	A	J	A	E	E	E
SHEET	1	2	3	4	5	6	7	8	9	10	11	12	13	14	15	16	17

GCR Read-Write
Type 9060
Schematic Diagram

These drawings and specifications are the property of Kennedy Company and shall not be reproduced or used in the base for the manufacture or sale of apparatus without permission.

A

A

B

B

C

C

D

D

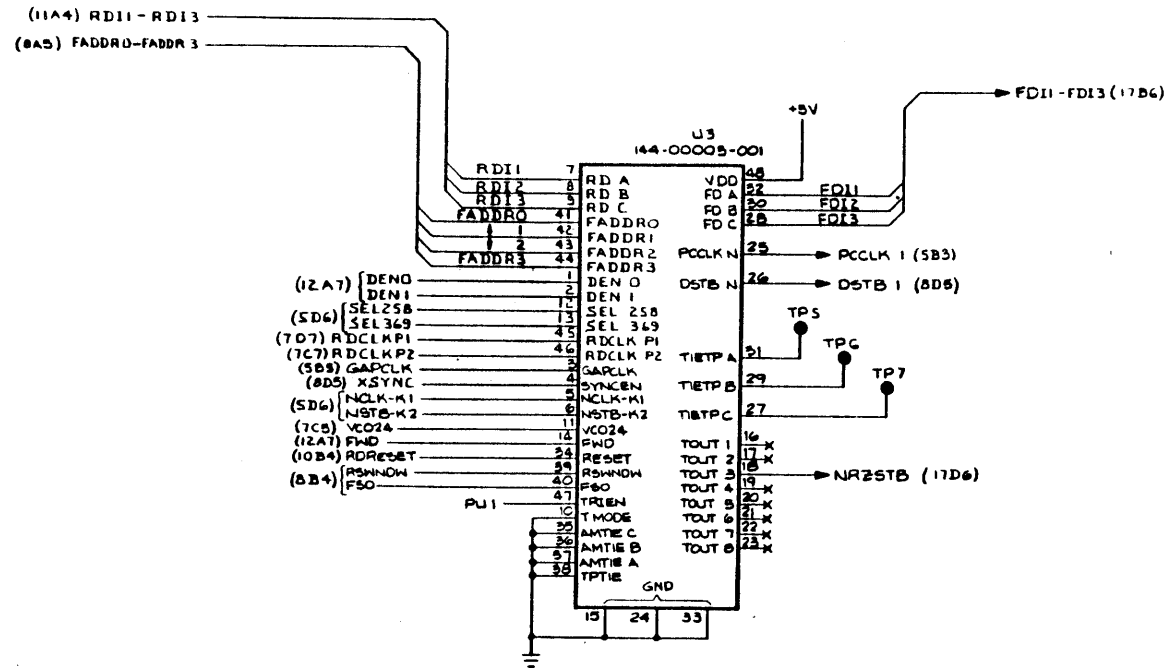

GCR Read-Write
Type 9060
Schematic Diagram

1

2

3

4

5

6

7

8

These drawings and specifications are the property of Kennedy Company and shall not be reproduced or copied or used in the same for the manufacture or sale of apparatus without permission.

401-09060-000 E
SHEET 3 OF 17

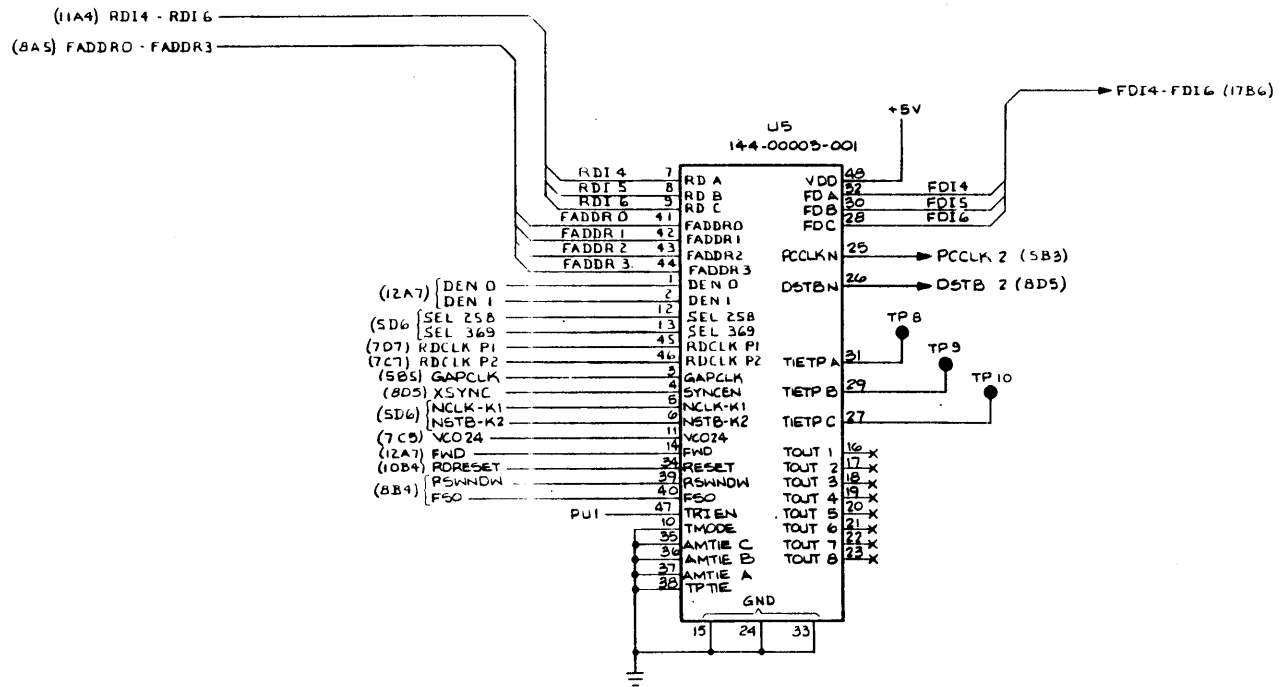

GCR Read-Write
Type 9060
Schematic Diagram

1 | 2 | 3 | 4 | 5 | 6 | 7

These drawings and specifications are the property of Kennedy Company and shall not be reproduced or copied or used in the field for the manufacture or sale of apparatus without permission

401-09060-000 E
SHEET 4 of 17

A

A

B

B

C

C

D

D

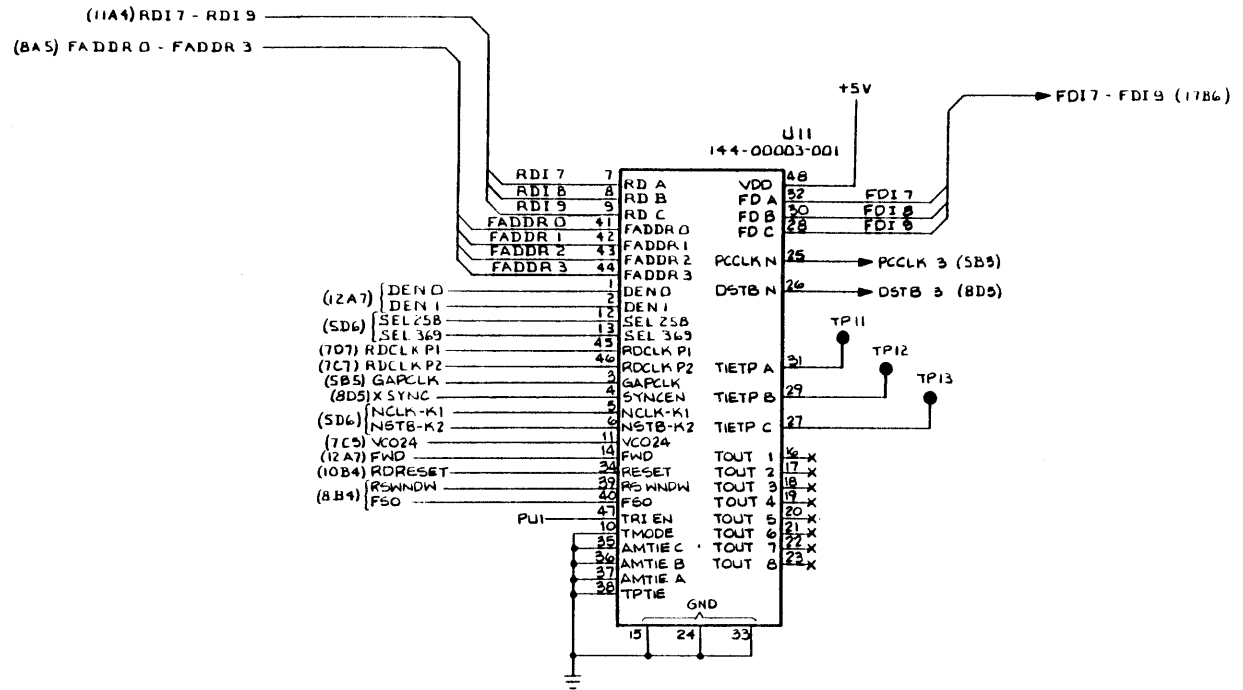

1 | 2 | 3 | 4 | 5 | 6 | 7 | 8

GCR Read-Write
Type 9060
Schematic Diagram

These drawings and specifications are the property of Amnody Company and shall not be reproduced or used in the form for the manufacture or sale of apparatus without permission.

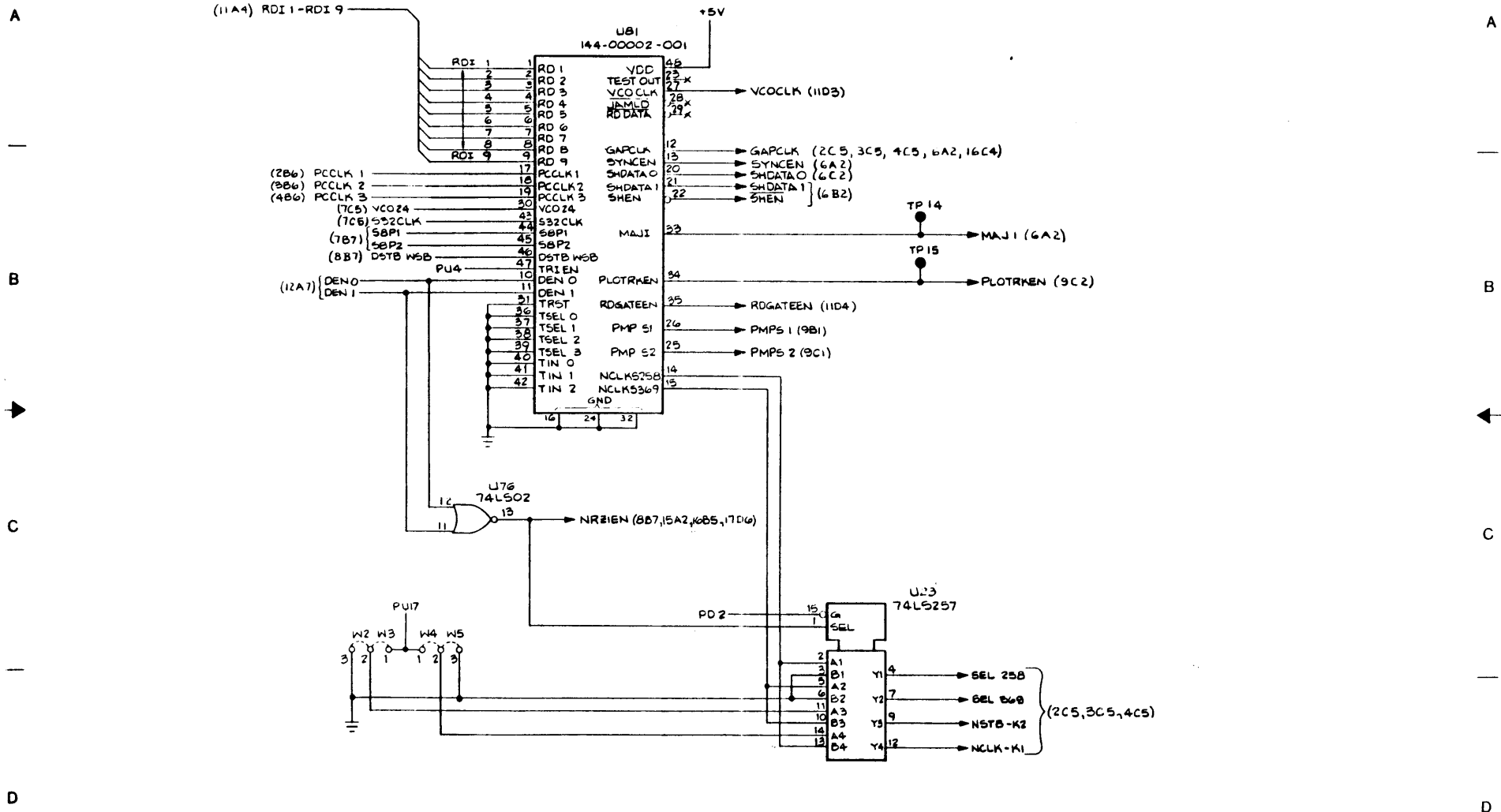

GCR Read-Write
Type 9060
Schematic Diagram

These drawings and specifications are the property of Kennedy Company and shall not be reproduced or copied or used in any form for the manufacture or sale of apparatus without permission.

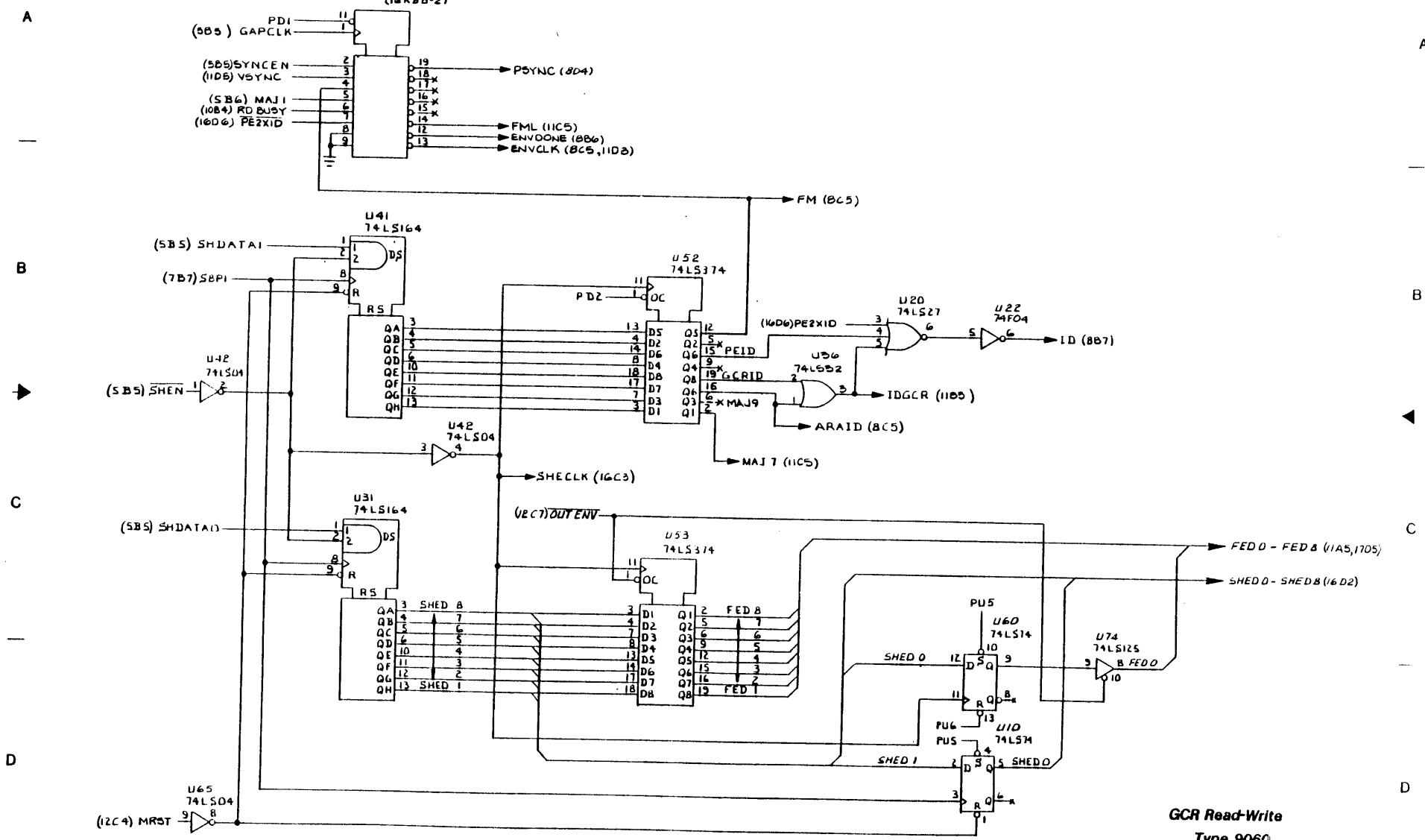

GCR Read-Write
Type 9060
Schematic Diagram

This drawing and specifications are the property of General Company and shall not be reproduced or used in whole or in part for the manufacture or sale of apparatus without permission.

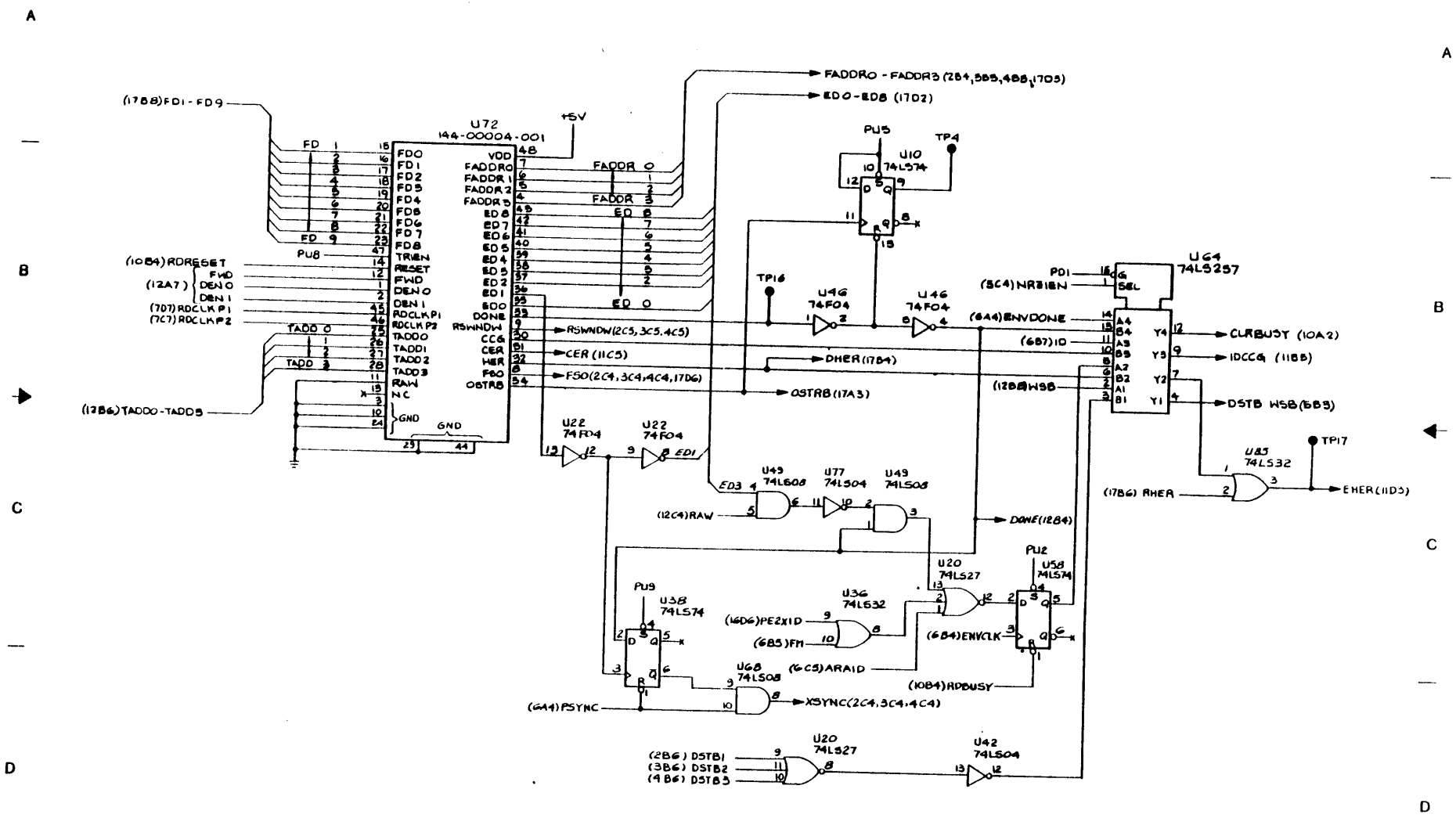

GCR Read-Write
Type 9060
Schematic Diagram

These drawings and specifications are the property of Kennedy Company and shall not be reproduced or copied or used in the same for the manufacture or sale of apparatus without permission.

401-09060-000E
SHEET 3 OF 17

A

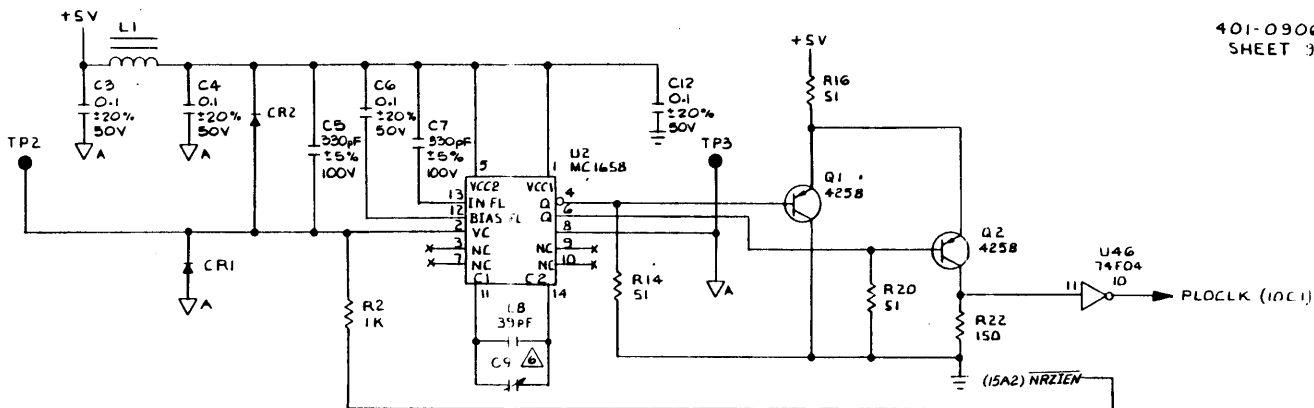

B

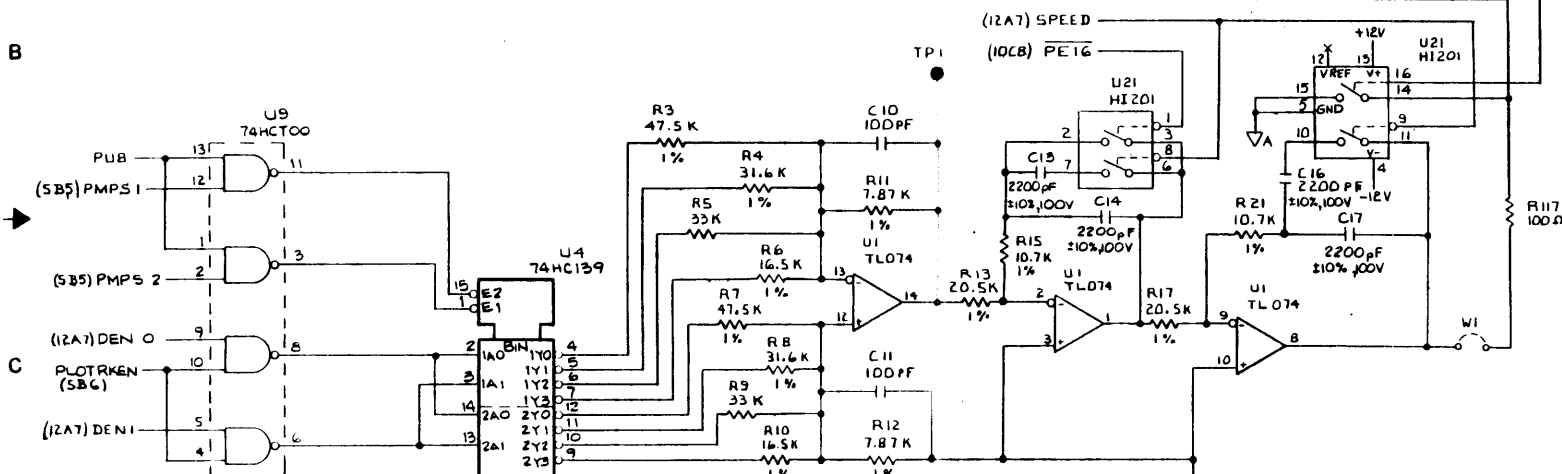

C

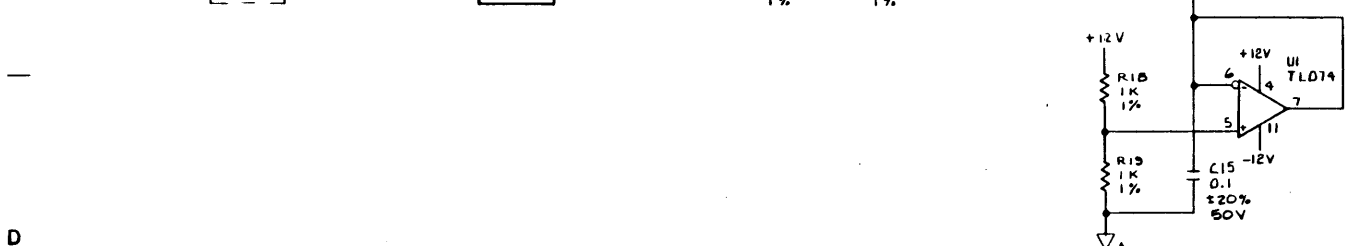

D

GCR Read-Write
Type 9060
Schematic Diagram

These drawings and specifications are the property of Kennedy Company and shall not be reproduced or copied in whole or in part for the manufacture or sale of apparatus without permission.

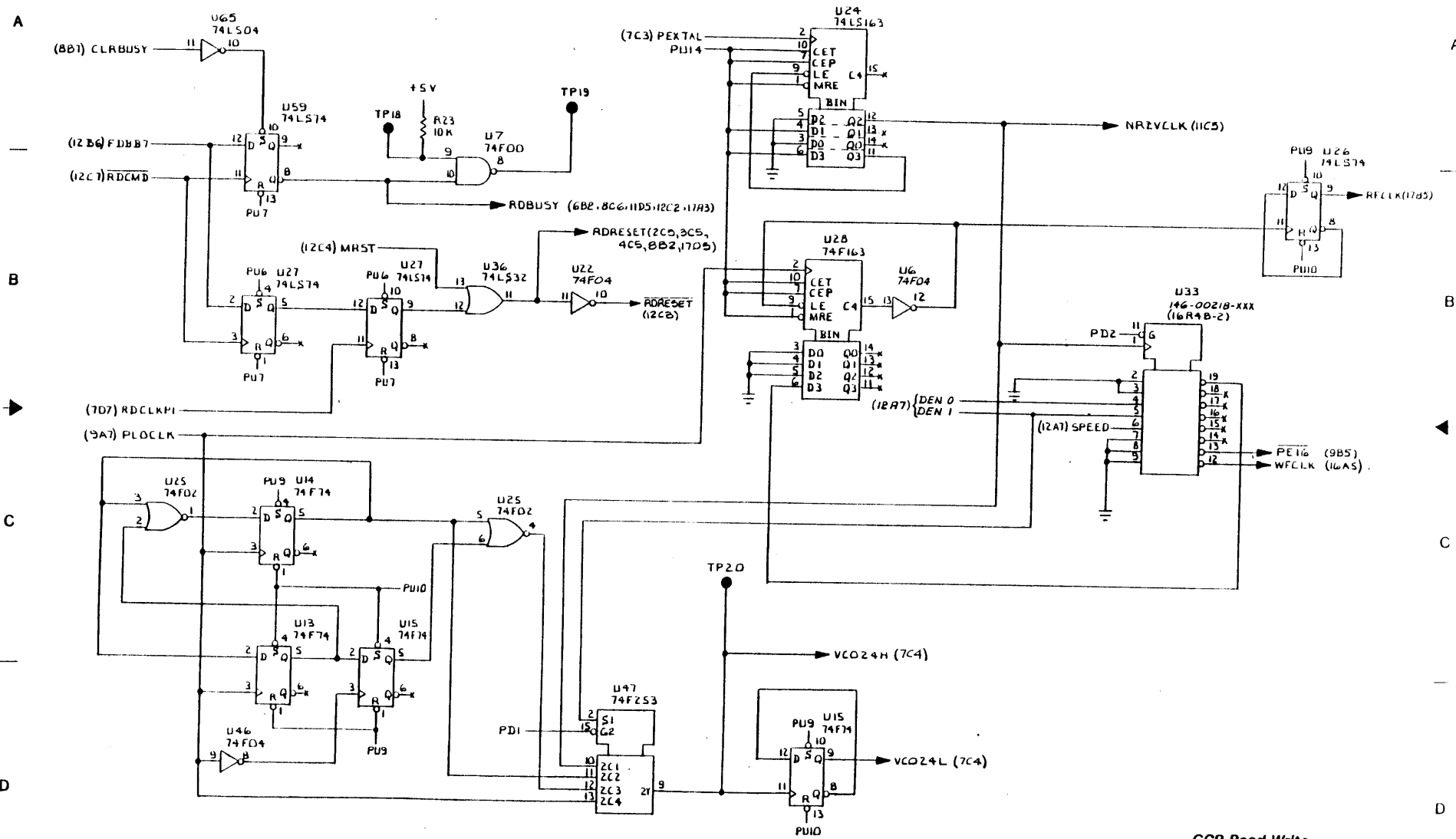

GCR Read-Write
Type 9060
Schematic Diagram

This drawing and specifications are the property of Kennedy Company and shall not be reproduced or copied, in whole or in part, for the manufacture or sale of apparatus without permission.

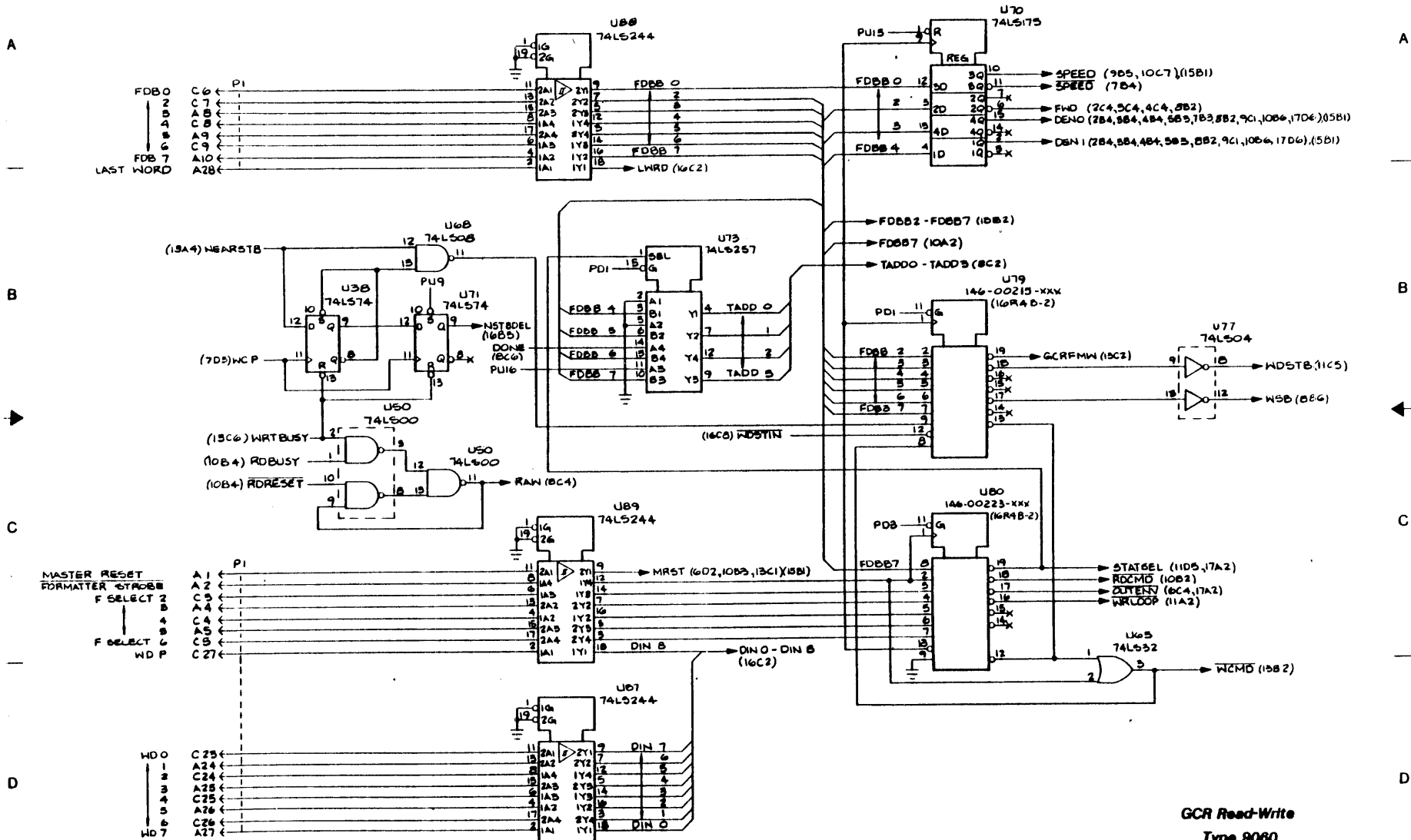

GCR Read-Write
Type 9060
Schematic Diagram

These drawings and specifications are the property of Kenwood Company and shall not be reproduced or copied or used as the basis for the manufacture or sale of apparatus without permission.

401-09060-000A
SHEET 13 OF 17

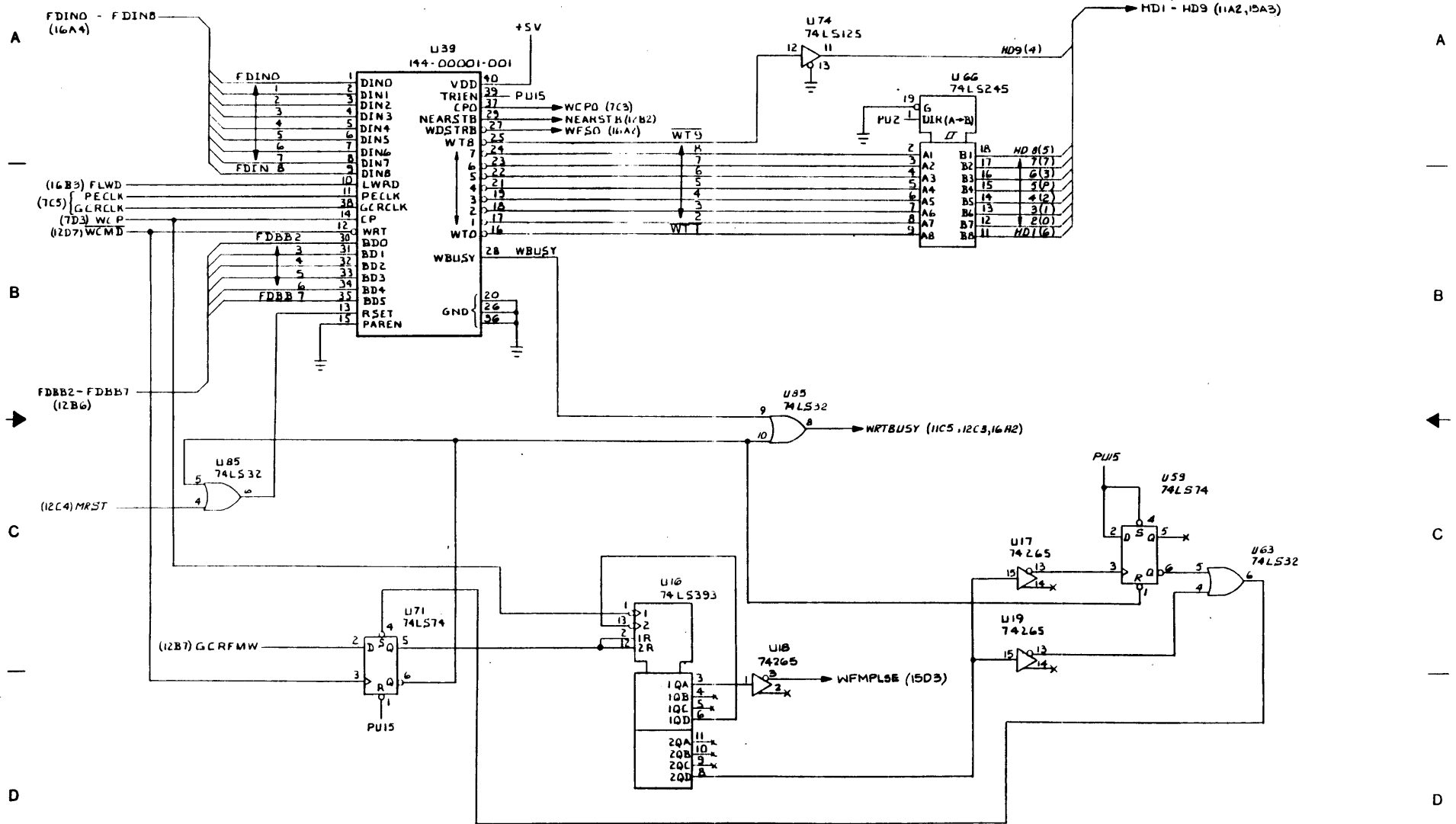

GCR Read-Write
Type 9060
Schematic Diagram

1 | 2 | 3 | 4 | 5 | 6 | 7 |

These drawings and specifications are the property of Remeney Company and shall not be reproduced or copied or used in any form for the manufacture or use of apparatus without permission.

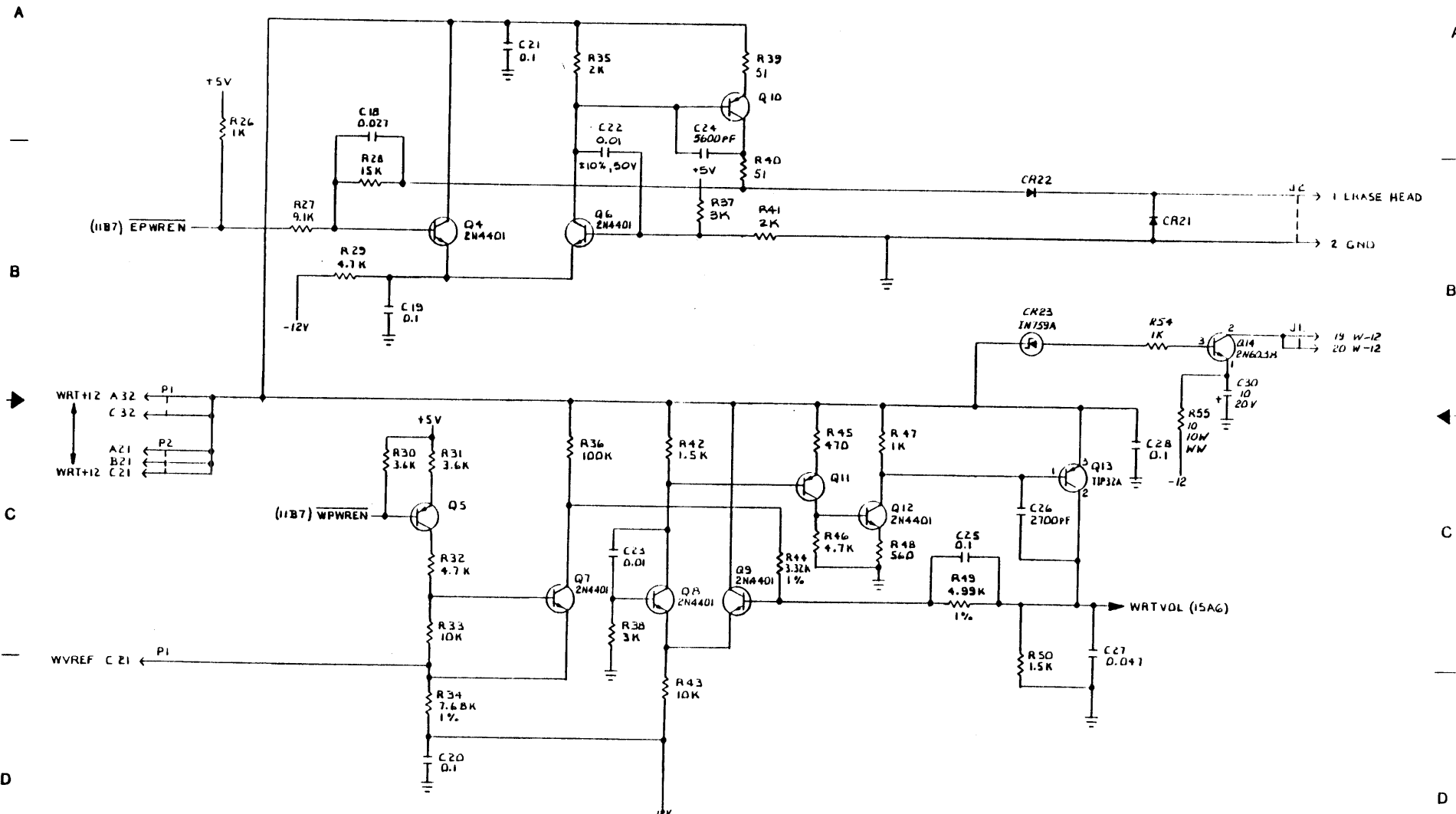

1 | 2 | 3 | 4 | 5 | 6 | 7 | 8

GCR Read-Write
Type 9060
Schematic Diagram

These drawings and specifications are the property of Kennedy Company and shall not be reproduced or used in any form for the manufacture or sale of equipment without permission.

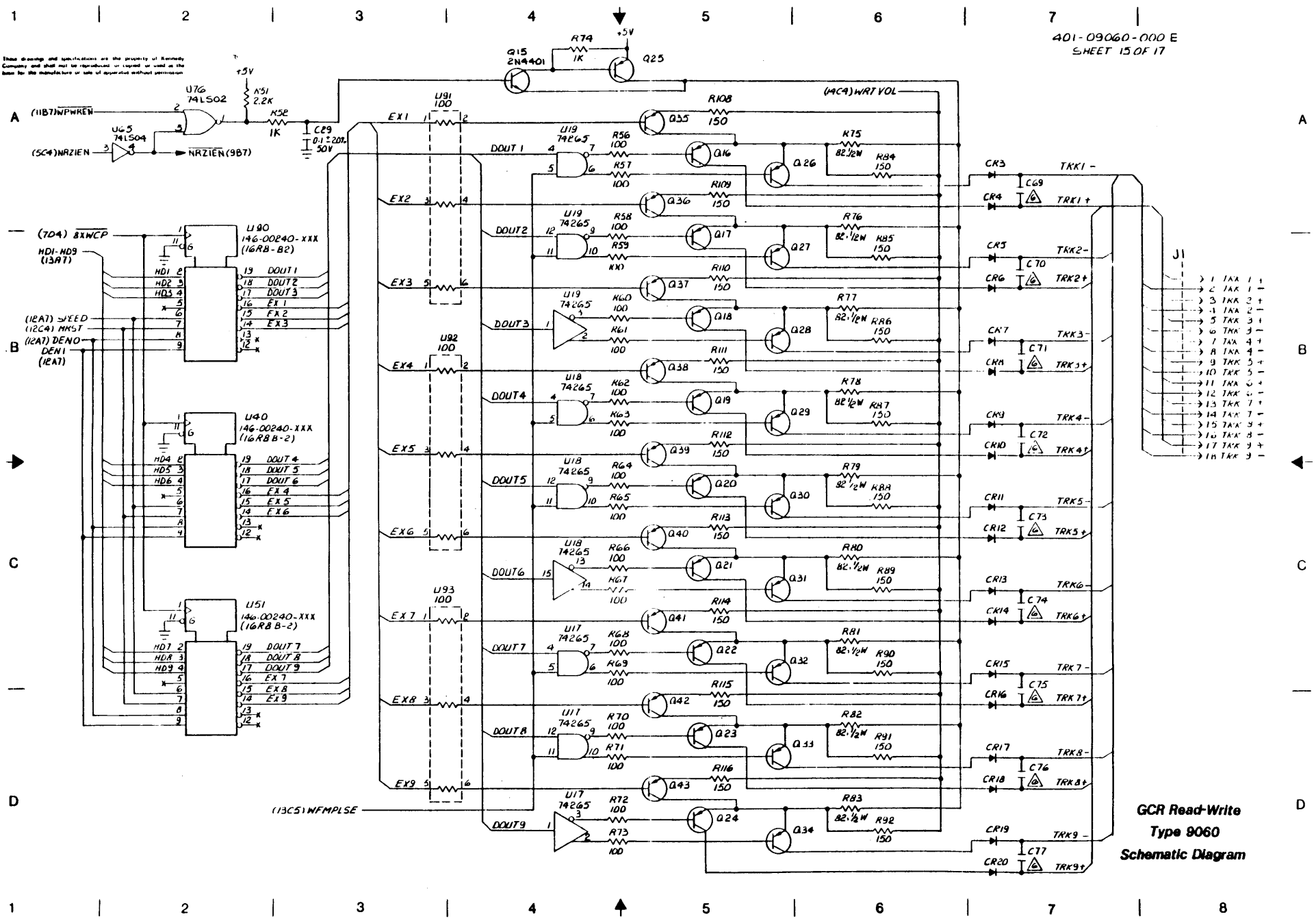

GCR Read-Write
Type 9060
Schematic Diagram

These drawings and specifications are the property of Remco Company and shall not be reproduced or copied or used in the base for the manufacture or sale of apparatus without permission.

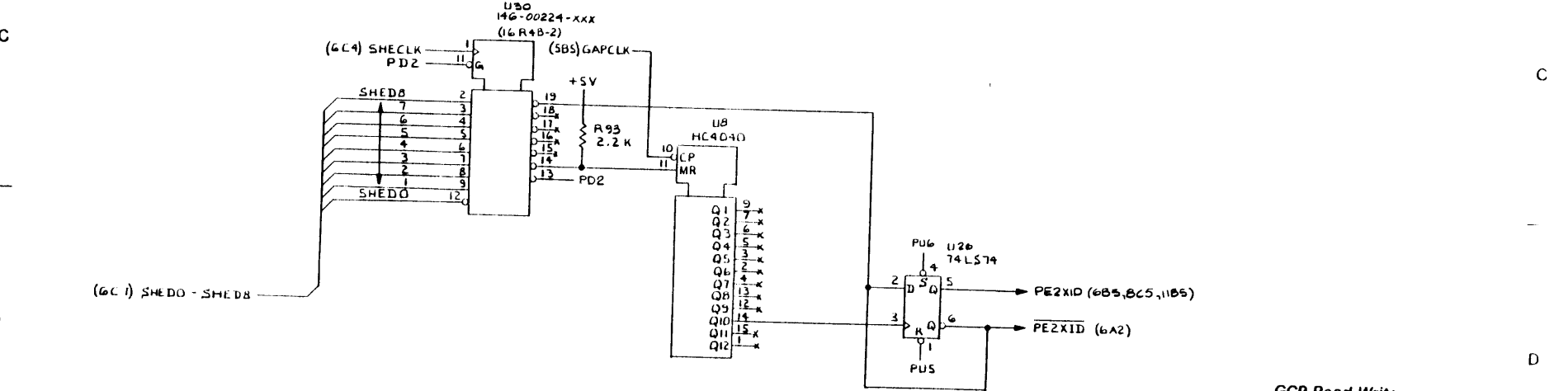
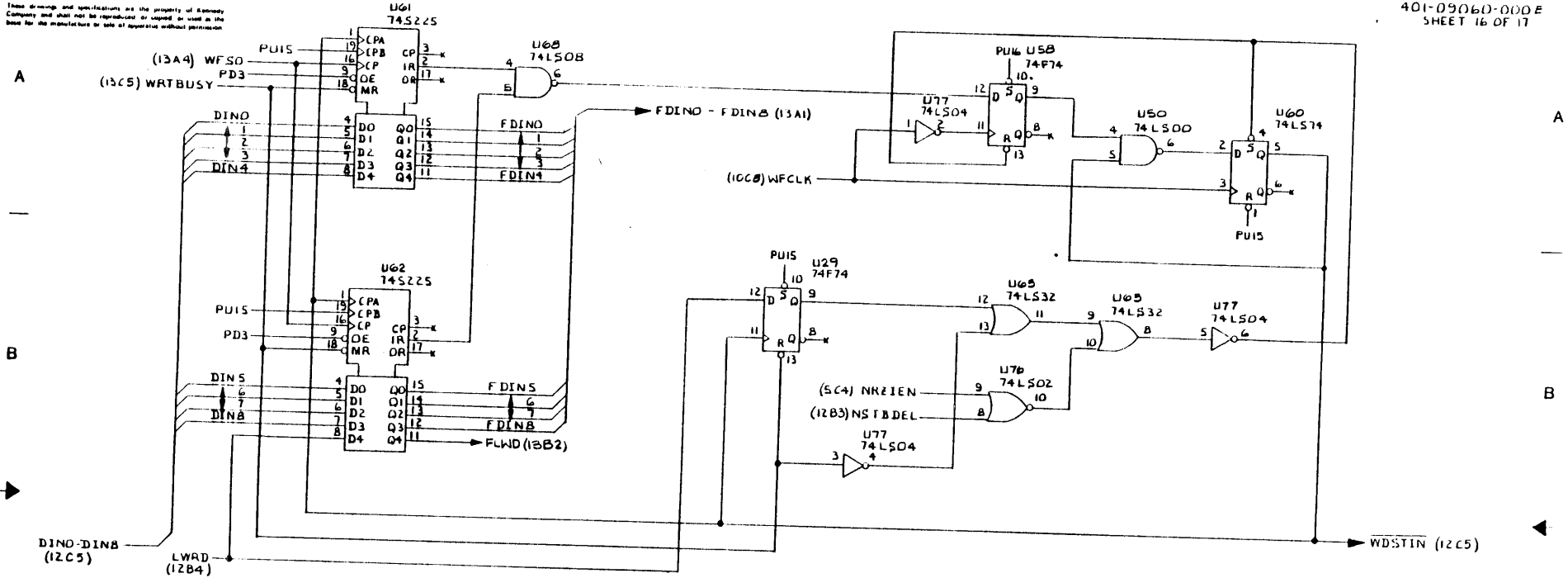

GCP Read-Write
Type 9060
Schematic Diagram

These drawings and specifications are the property of Kennedy Company and shall not be reproduced or copied or used in the field for the manufacture or sale of apparatus without permission.

401-6923-000 REV A
SH. 1 OF 1

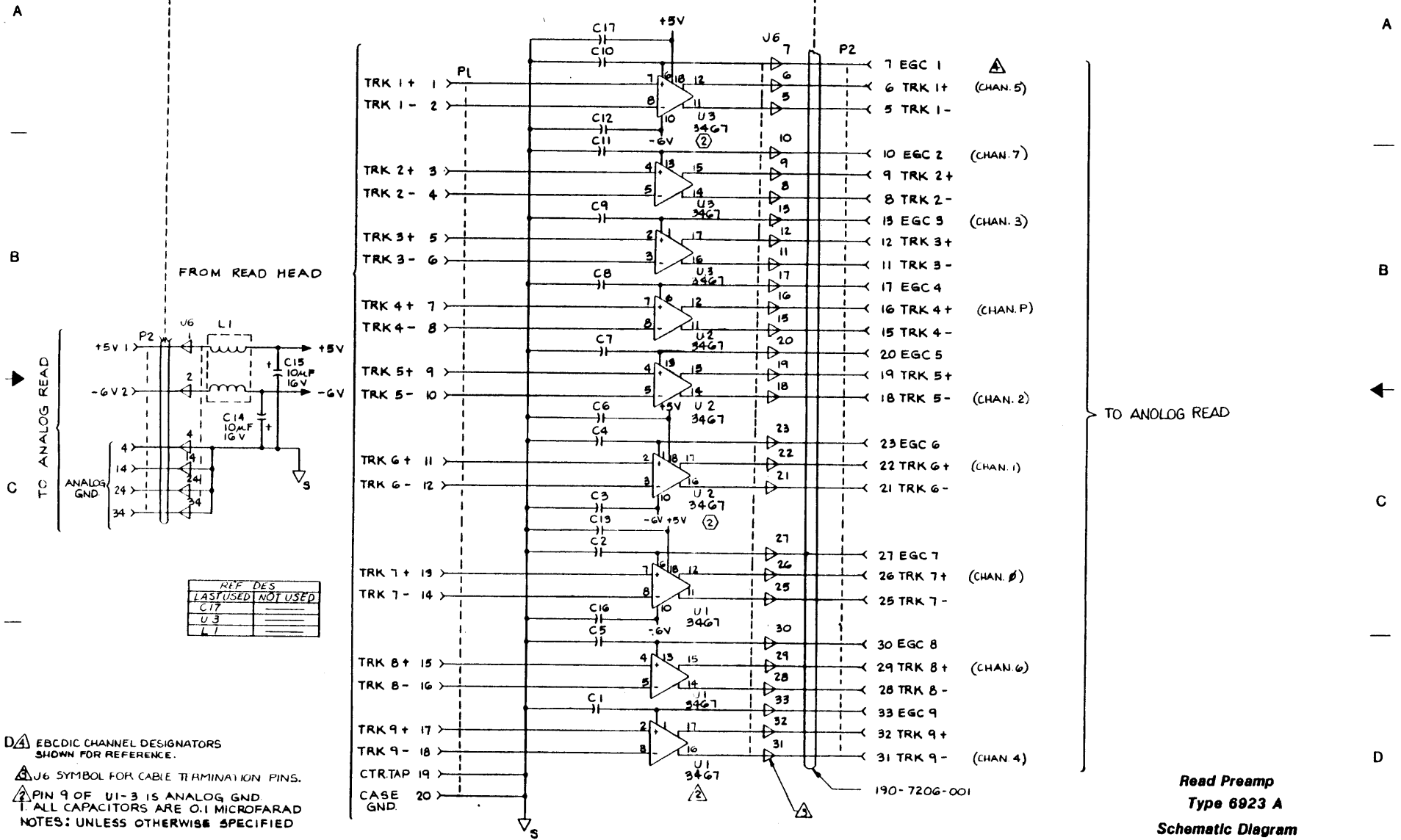

⚠ EBCDIC CHANNEL DESIGNATORS SHOWN FOR REFERENCE.

⚠ J6 SYMBOL FOR CABLE TERMINATION PINS.

⚠ PIN 9 OF U1-3 IS ANALOG GND

⚠ ALL CAPACITORS ARE 0.1 MICROFARAD

NOTES: UNLESS OTHERWISE SPECIFIED

Read Preamp
Type 6923 A
Schematic Diagram

This drawing and specifications are the property of General Company and shall not be reproduced, stored, or used in the form for the manufacture or sale of equipment without permission.

190-09017-KXX TABULATION

DASH NO	REV	DASH NO	REV
-005	A	-105	A
U23	146-00225-003	146-00225-002	
U25	146-00226-002	146-00226-002	
U30	146-00221-002	146-00227-002	
UA08	146-00228-003	146-00228-003	

A

B

C

D

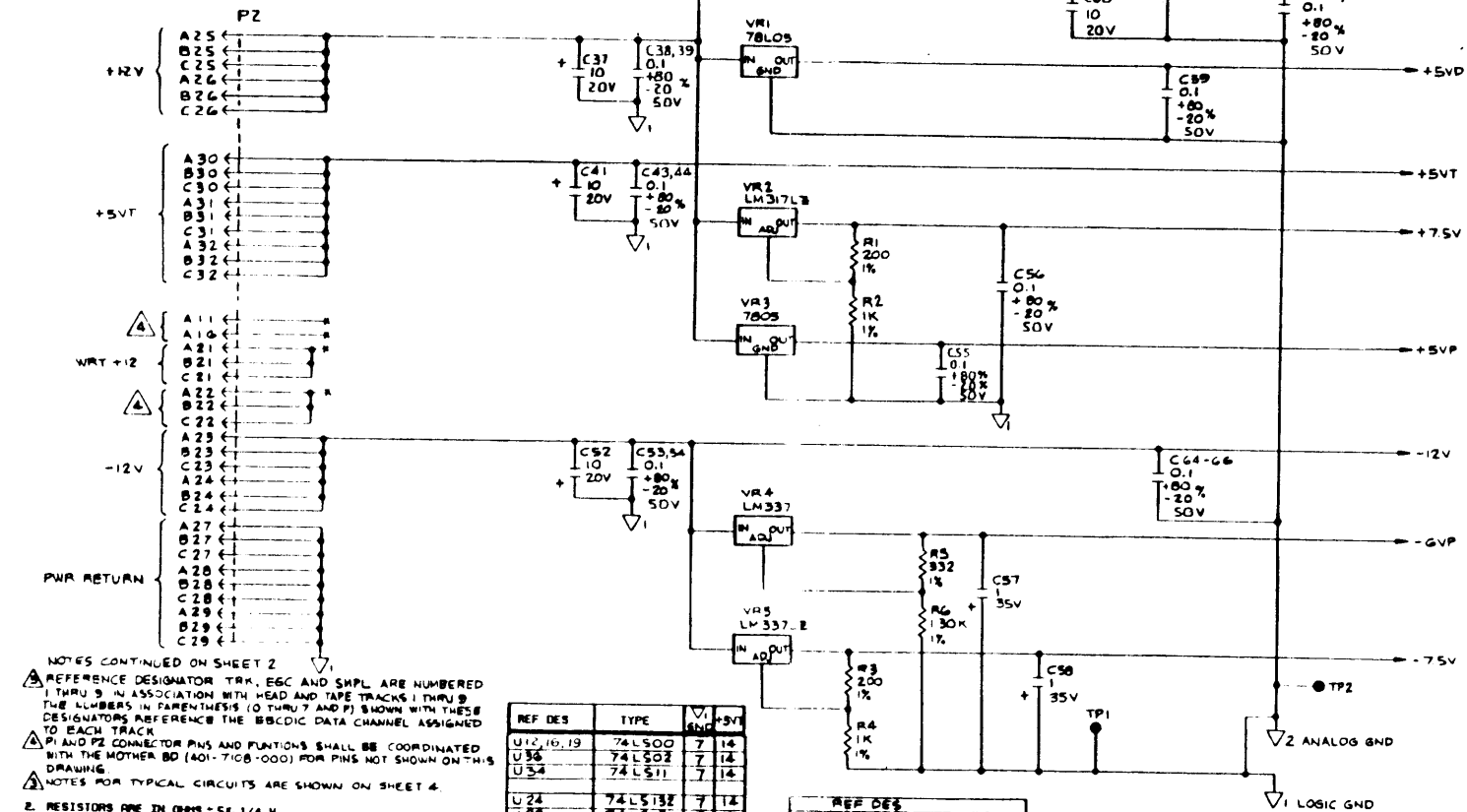

- NOTES CONTINUED ON SHEET 2
- ▲ REFERENCE DESIGNATOR TRK, ESC AND SHPL ARE NUMBERED 1 THRU 9 IN ASSOCIATION WITH HEAD AND TAPE TRACKS 1 THRU 9 THE NUMBERS IN PARENTHESES (O THRU 7 AND P) SHOWN WITH THESE DESIGNATORS REFERENCE THE BB/CDC DATA CHANNEL ASSIGNED TO EACH TRACK.
 - ▲ P1 AND P2 CONNECTOR PINS AND FUNCTIONS SHALL BE COORDINATED WITH THE MOTHER BD (401-7108-000) FOR PINS NOT SHOWN ON THIS DRAWING.
 - ▲ NOTES FOR TYPICAL CIRCUITS ARE SHOWN ON SHEET 4.

- 2. RESISTORS ARE IN OHMS = 54.1/4 W.
- 1. CAPACITORS ARE IN MICROFARADS = 18X 50V

NOTES: UNLESS OTHERWISE SPECIFIED

REV STATUS OF SHEETS	REV SHEET	B	A	A	A	A	A	A	A
		1	2	3	4	5	6	7	8

REF DES	TYPE	V _I	V _O	+5V
U12,16,19	74LS00	7	14	
U36	74LS02	7	14	
U34	74LS11	7	14	
U24	74LS132	7	14	
U28	74LS151	8	16	
U13	74LS161	8	16	
U32	74LS163	8	16	
U15	74LS193	8	16	
U27	74LS240	10	20	
U17,17,35	74LS244	10	20	
U6,26,31	74LS374	10	20	
U57	74LS593	7	14	
U23,25,30	825125	8	16	
U21	7406	7	14	
U22	2114	-	18	
U29,30,41	74LS221	8	16	

REF DES	LAST USED	NOT USED
C23	C1,4,36,40,42,45-51,63	
G2		
R7	R9,42,61	
U51	U4,7,14	
VR5		
VR2		

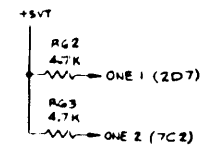

Read Analog
Type 9017
Schematic Diagram

These drawings and specifications are the property of Kennedy Company and shall not be reproduced, or copied, or used in the form for the manufacture or sale of apparatus without permission.

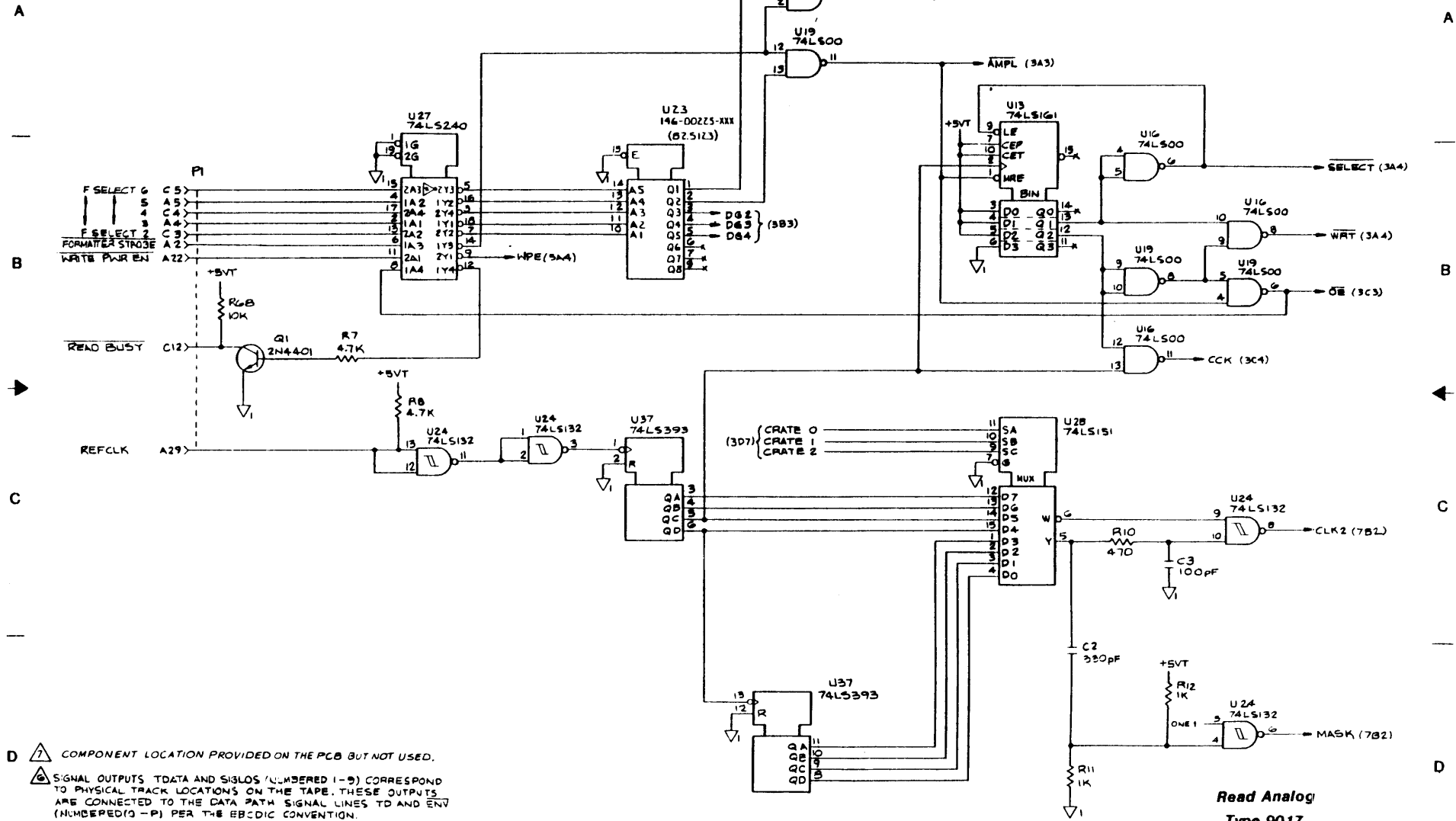

- D COMPONENT LOCATION PROVIDED ON THE PCB BUT NOT USED.
- SIGNAL OUTPUTS (DATA AND SIGLOS (NUMBERED 1-9)) CORRESPOND TO PHYSICAL TRACK LOCATIONS ON THE TAPE. THESE OUTPUTS ARE CONNECTED TO THE DATA PATH SIGNAL LINES TD AND EN (NUMBERED 10-19) PER THE EBCDIC CONVENTION.

Read Analog
Type 9017
Schematic Diagram

This drawing and specifications are the property of Kennedy Company and shall not be reproduced or copied, or used in the base for the manufacture or sale of apparatus without permission.

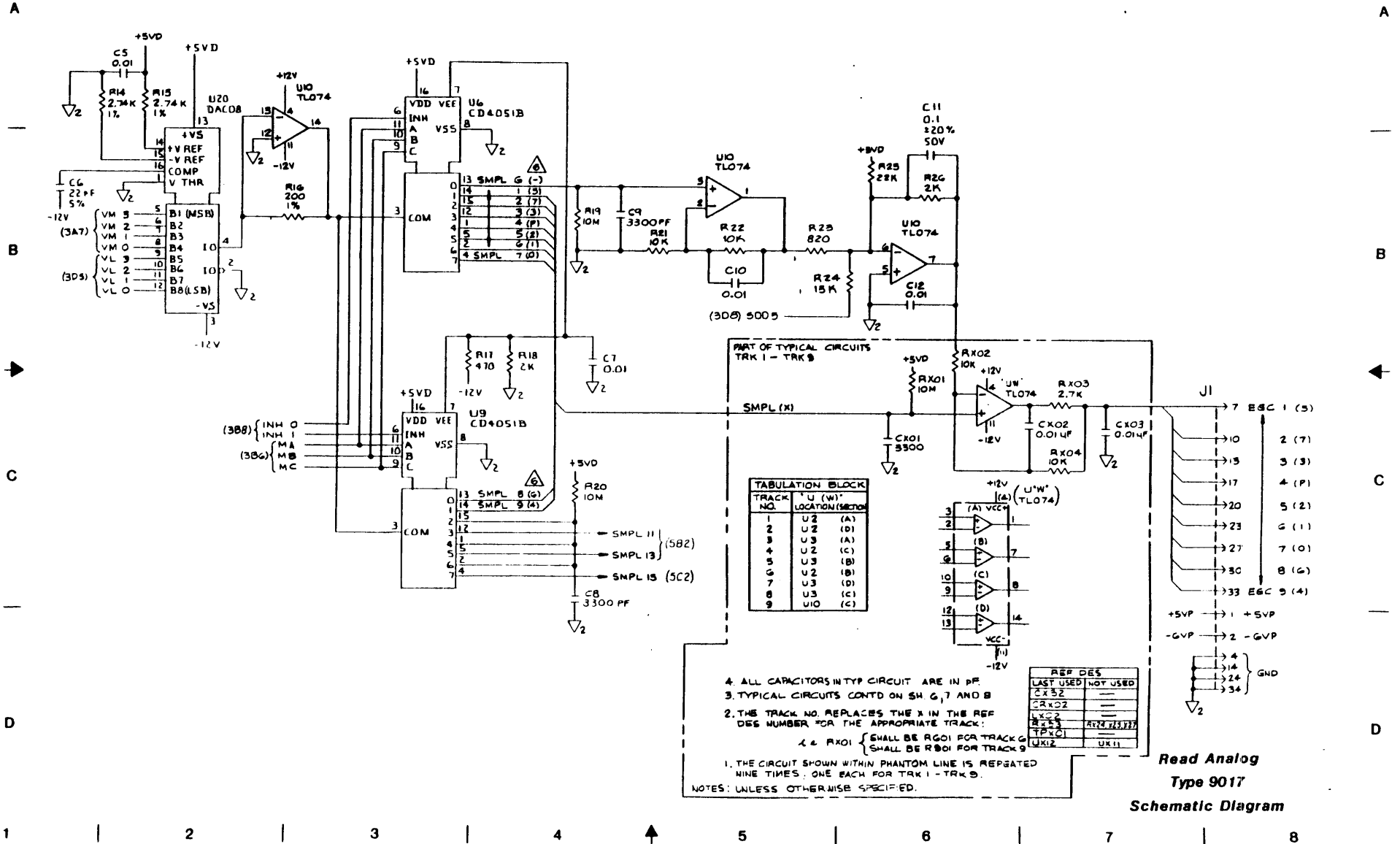

Read Analog
Type 9017
Schematic Diagram

These drawings and specifications are the property of Kennedy Company and shall not be reproduced or copied in whole or in part for the manufacture or sale of apparatus without permission.

401-09017-100 A
SHEET 5 OF 8

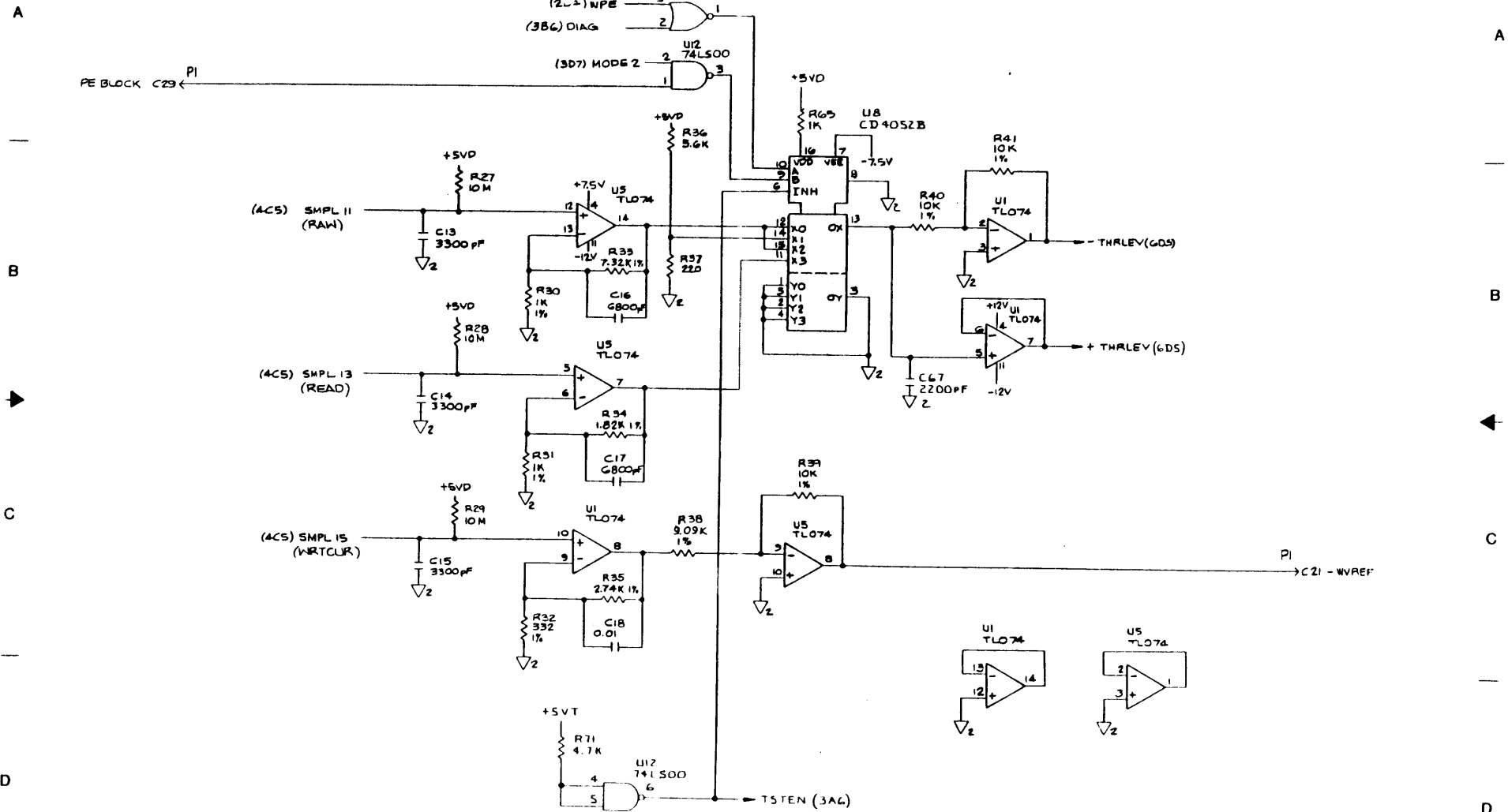

Read Analog
Type 9017
Schematic Diagram

1 | 2 | 3 | 4 | 5 | 6 | 7

These drawings and specifications are the property of Kennedy Company and shall not be reproduced or copied in whole or in part for the manufacture or sale of electrical products without permission.

401-09017-100 A
SHEET 6 of 8

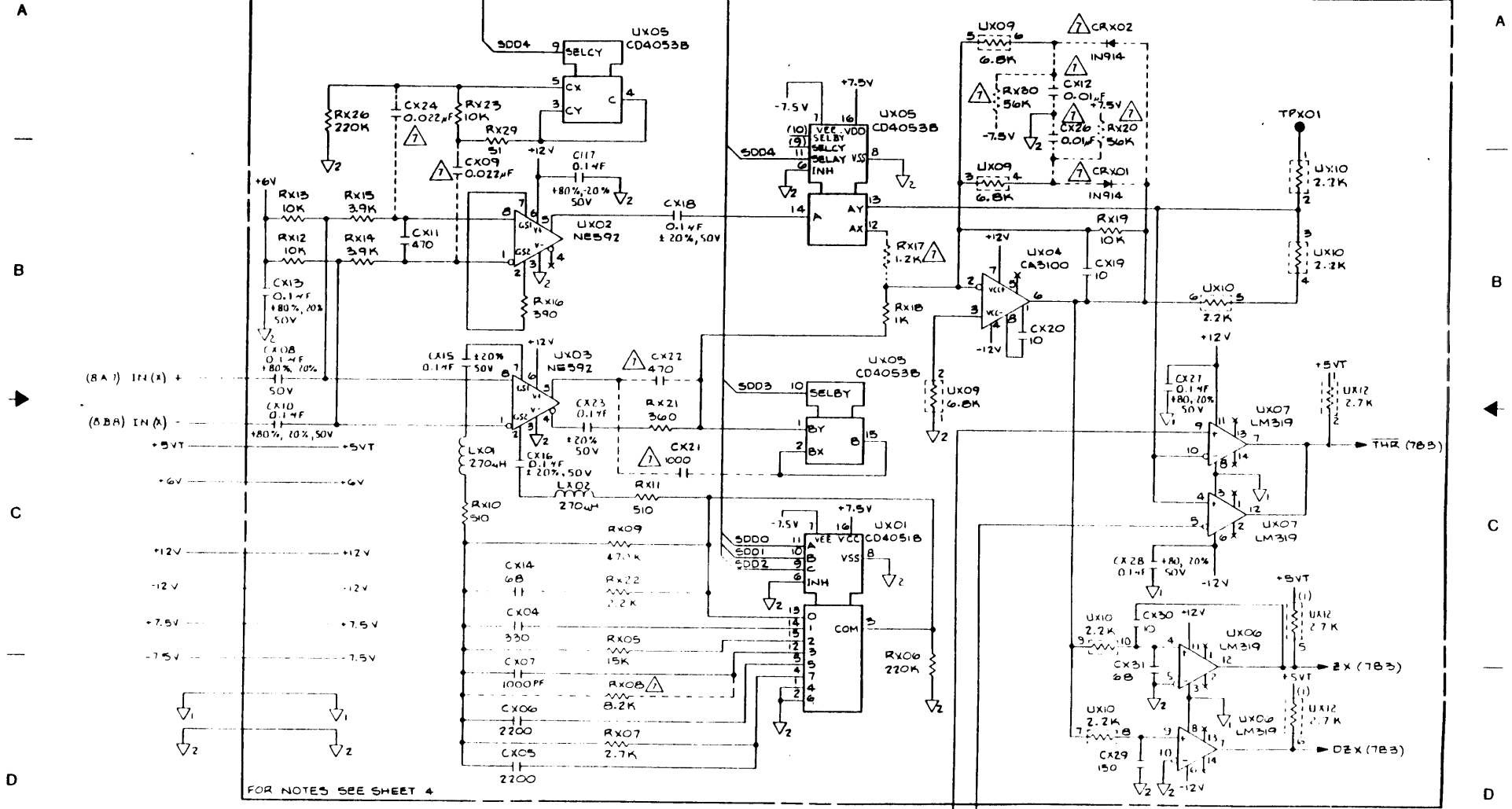

C

D

(5B6) - THRLEV
(5B0) - THRLEV
Read Analog
Type 9017
Schematic Diagram

1 | 2 | 3 | 4 | 5 | 6 | 7 | 8

1 | 2 | 3 | 4 | 5 | 6 | 7

This drawing and specifications are the property of Remko Company and shall not be reproduced, in whole or in part, for the manufacture or sale of apparatus without permission.

401-09011-100 A
SHEET 8 OF 8

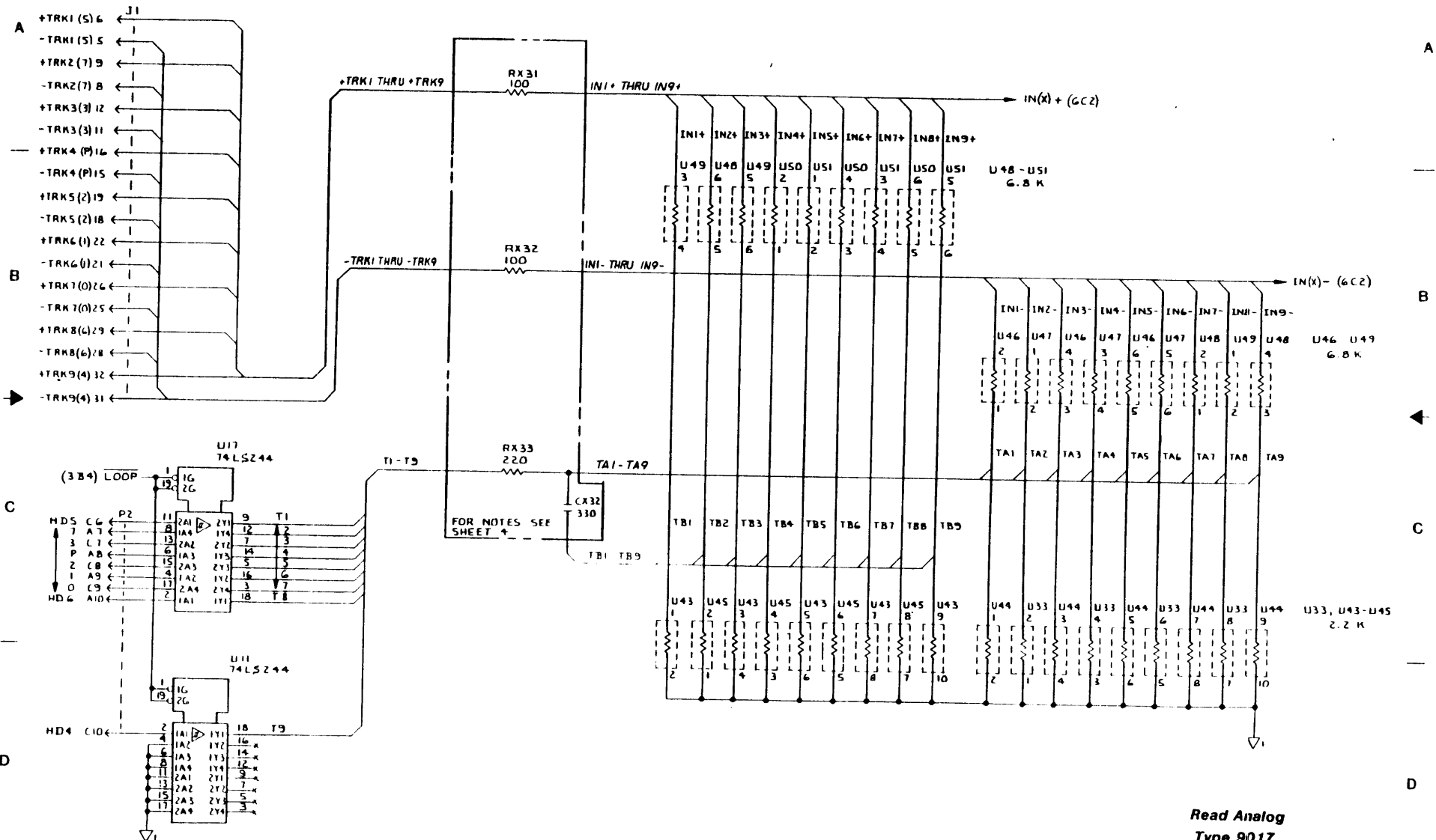

1 | 2 | 3 | 4 | 5 | 6 | 7 | 8

Read Analog
Type 9017
Schematic Diagram

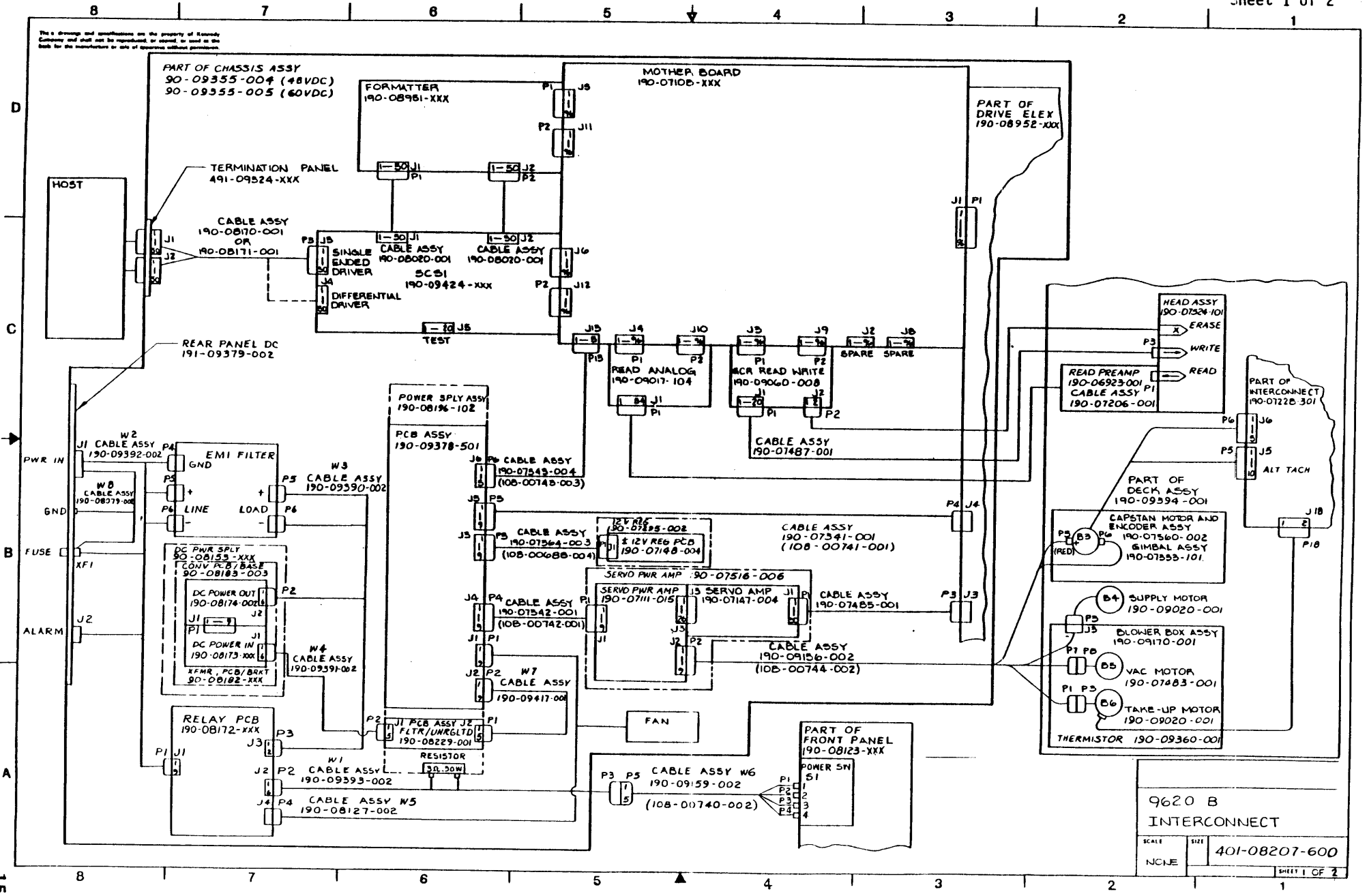

9620 B	
INTERCONNECT	
SCALE	SIZE
NC/E	401-08207-600
SHEET 1 OF 2	

15-2

This drawing and specifications are the property of Kvaerd Company and shall not be reproduced or used in whole or in part for any manufacture or sale of equipment without prior written permission.

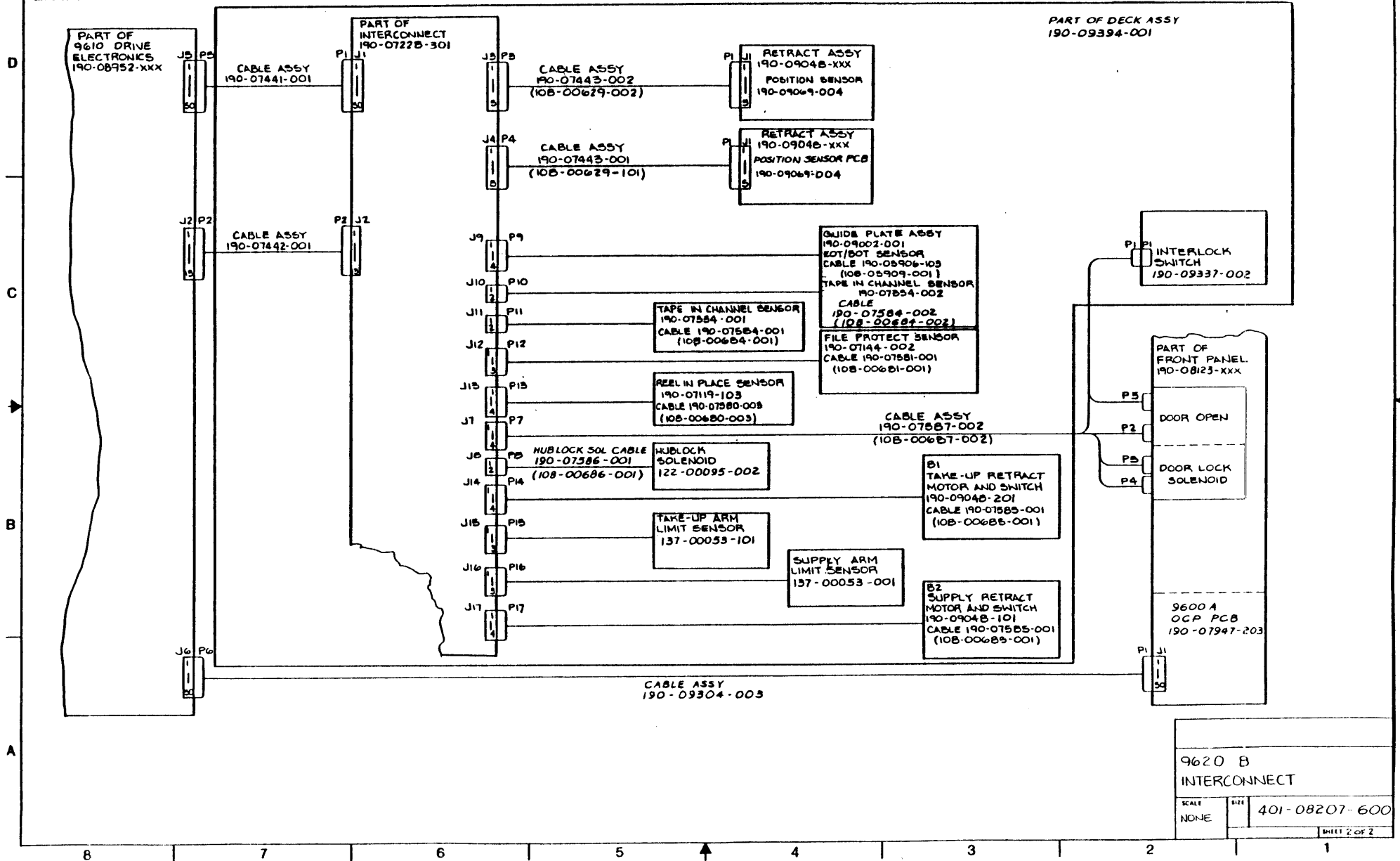

9620 B	
INTERCONNECT	
SCALE	SIZE
NONE	401-08207-600
SHEET 2 OF 2	

The drawings and specifications are the property of Kennedy Company and shall not be reproduced or copied in whole or in part for the manufacture or sale of apparatus without permission.

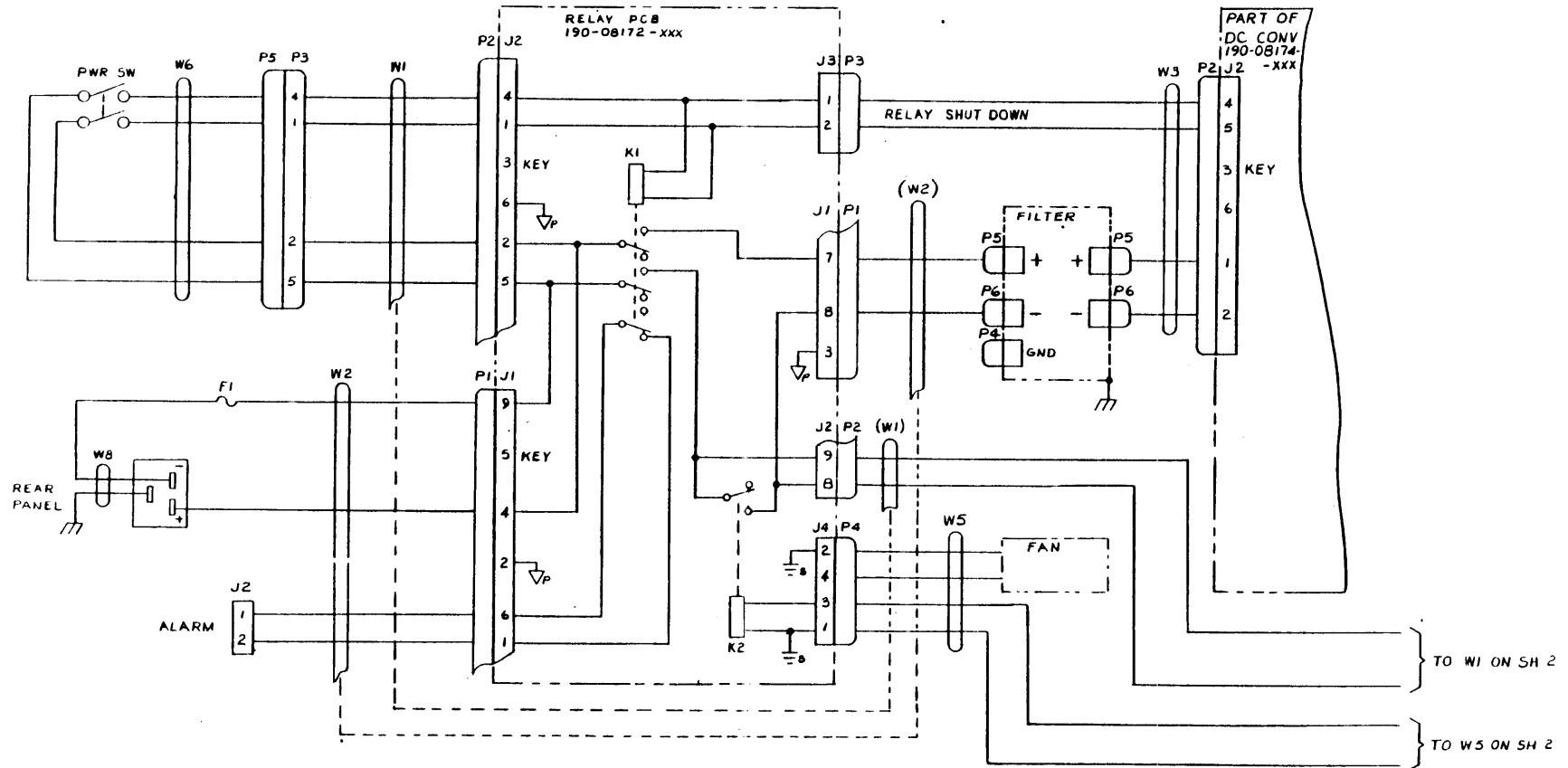

CABLE NO	PART NO
W1	190-09393-XXX
W2	190-09392-XXX
W3	190-09390-XXX
W4	190-09391-XXX
W5	190-08127-XXX
W6	190-09159-XXX
W7	190-09417-XXX
W8	190-08079-XXX

9620 POWER SUPPLY
INTCON DIAG
SCALE SIZE 401-08222-000
SHEET 1 OF 2

This drawing and specifications are the property of Kennedy Company and shall not be reproduced or used in the base for the manufacture or sale of spares without permission.

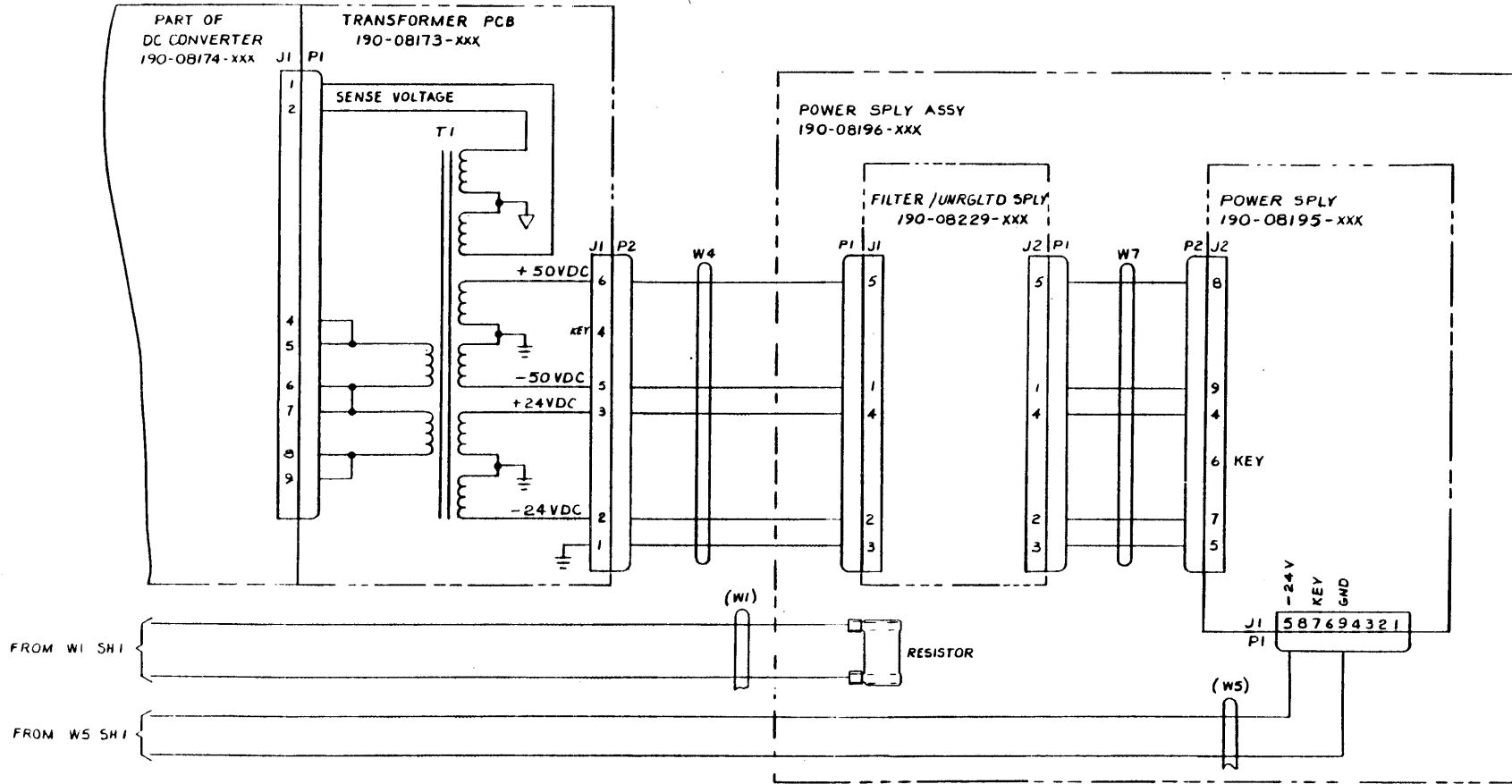

9620 POWER SUPPLY	
INTCON DIAG	
SCALE	SIZE
	401-08222-000
SHEET 2 OF 2	

These drawings and specifications are the property of Kennedy Company and shall not be reproduced or copied in whole or in part for the manufacture or sale of apparatus without permission.

401-08172-000 D
SHT 1 OF 1

90-08172-XXX TABULATION

REF DES	DASH NO	REV	DASH NO	REV
	-002	B	-502	B
48 VDC P3		60VDC P3		
R1	31.6K, 1%	40.2K 1/6		

A

A

B

B

C

C

D

D

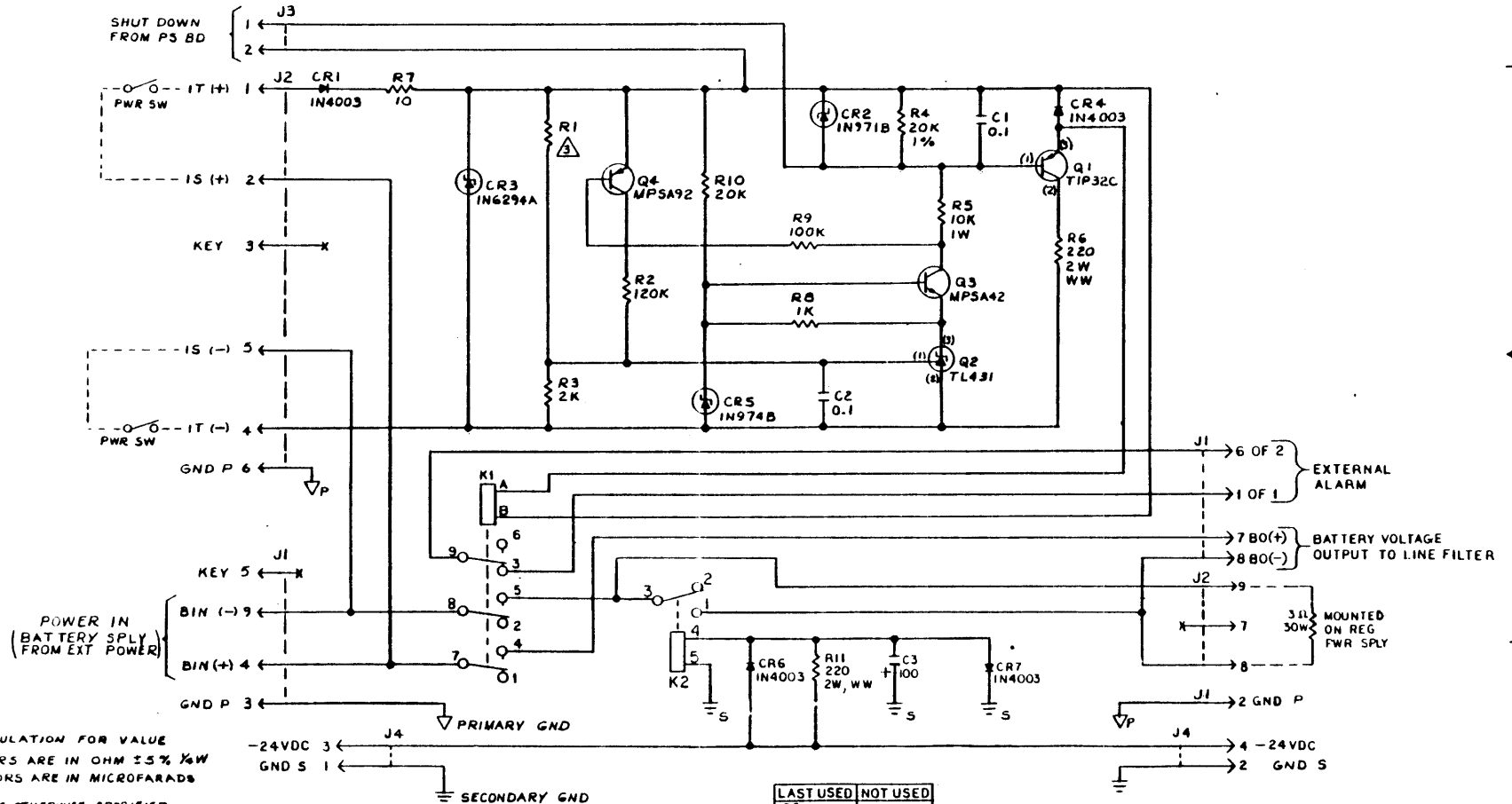

SEE TABULATION FOR VALUE
2. RESISTORS ARE IN OHM 5% 1/6W
1. CAPACITORS ARE IN MICROFARADS

NOTES UNLESS OTHERWISE SPECIFIED

REV STATUS	REV	D
OF SHEETS	SHEET	1

LAST USED	NOT USED
C3	
CR7	
J4	
Q4	
R11	
K2	

Relay Board
Type 8172
Schematic Diagram

These drawings and specifications are the property of Kennedy Company and shall not be reproduced or copied in any form for the manufacture or sale of apparatus without permission.

90-9378-TABULATION

REF DES	DASH NO	REV
	-501	B

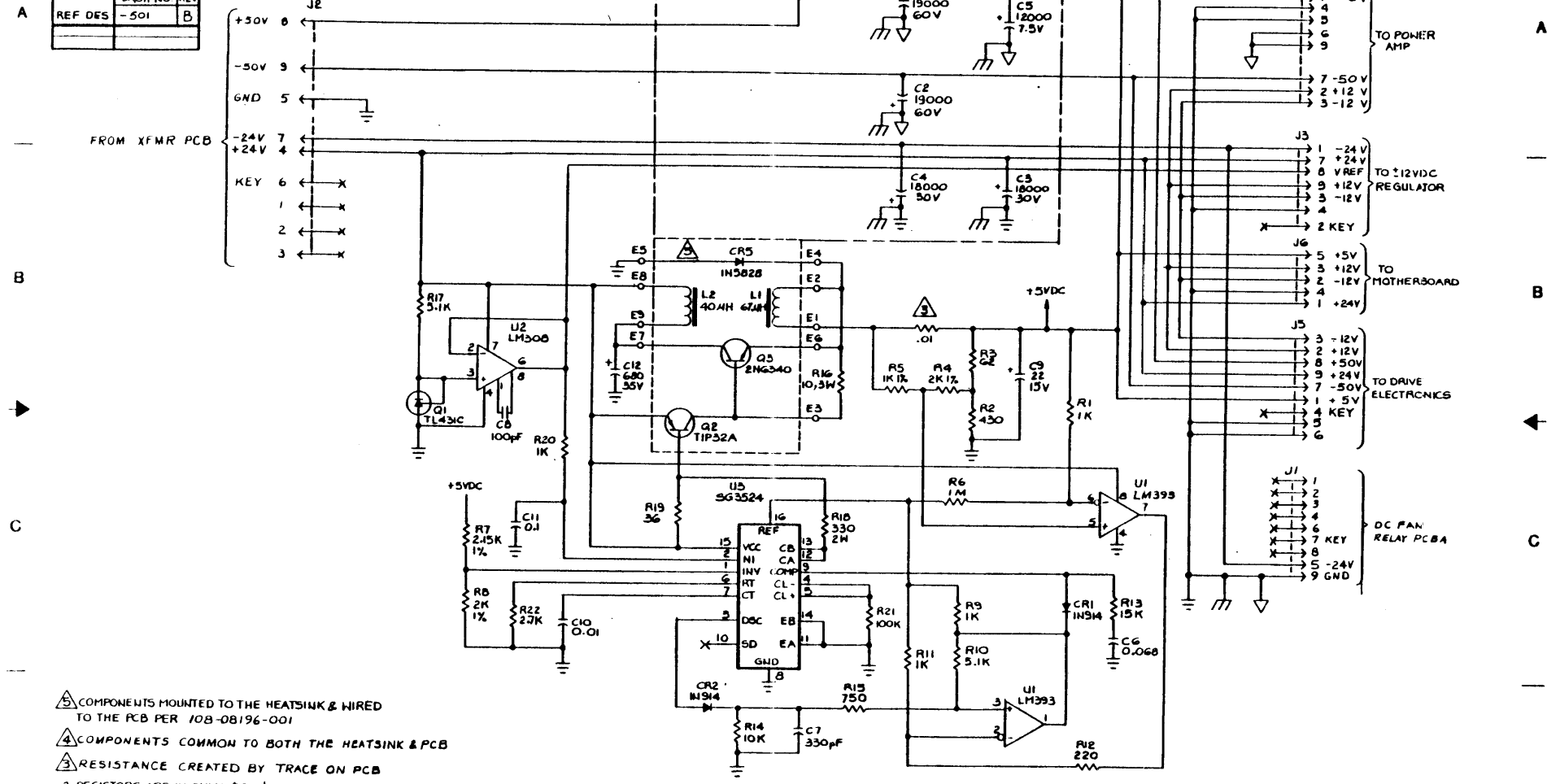

- ⚠ COMPONENTS MOUNTED TO THE HEATSINK & WIRED TO THE PCB PER 108-08196-001
- ⚡ COMPONENTS COMMON TO BOTH THE HEATSINK & PCB
- ⚡ RESISTANCE CREATED BY TRACE ON PCB

2. RESISTORS ARE IN OHMS ±5% 1/4W
1. CAPACITORS ARE IN MICROFARADS ±10% 50V
NOTES: UNLESS OTHERWISE SPECIFIED

REV STATUS OF SHEETS	REV SHEET	C
		1

LAST USED	NOT USED
R22	CR3, CR4
CR5	
L2	
Q3	
U3	
E2	
C2	
I6	

**Power Supply +5V DC
Type 9378 DC
Schematic Diagram**

1 | 2 | 3 | 4 ↓ 5 | 6 | 7 |

This drawing and specifications are the property of Kennedy Company and shall not be reproduced or copied or used in the sale for the manufacture or use of apparatus without permission.

401-08229-000 A
SHEET 1 OF 1

A

A

B

B

C

C

D

D

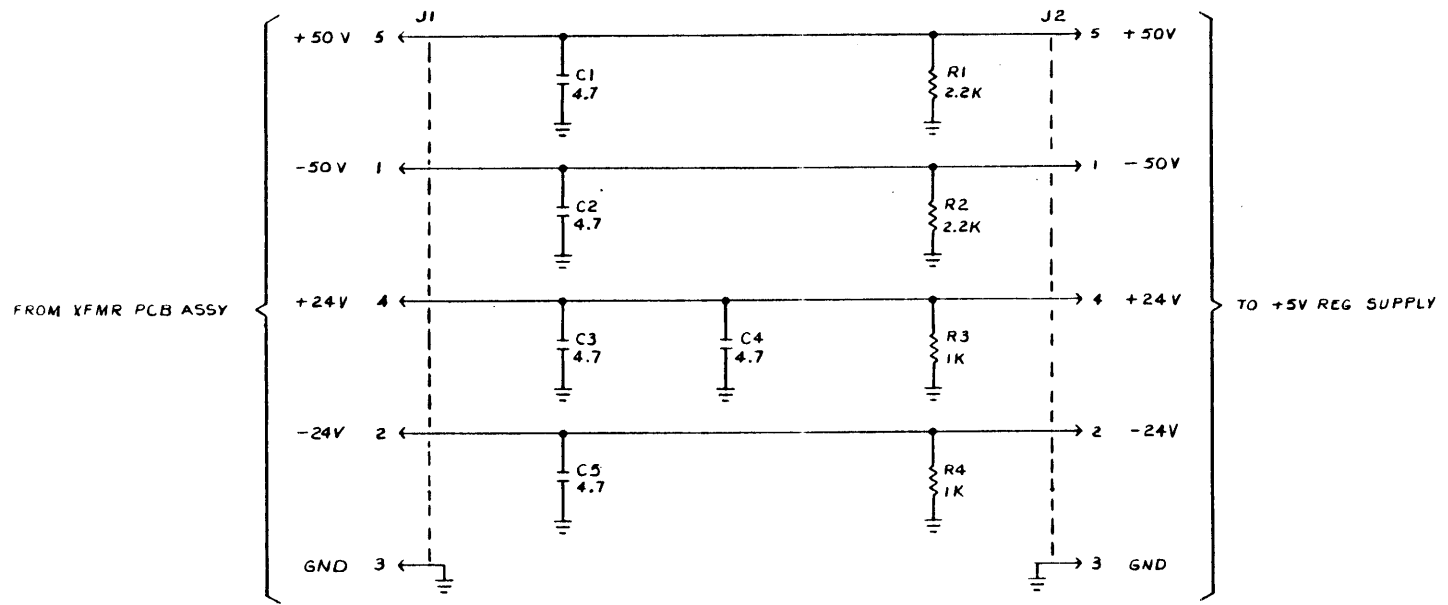

2 RESISTORS ARE 3W, WW
1 CAPACITORS ARE 1N, 1F ± 20% 100V
NOTES: UNLESS OTHERWISE SPECIFIED

FLTR/ UNRGLTD SPLY
Type 8229
SCHEMATIC DIAGRAM

1 | 2 | 3 | 4 ↑ 5 | 6 | 7 | 8

1 | 2 | 3 | 4 | 5 | 6 | 7

These drawings and specifications are the property of Kennedy Company and shall not be reproduced or copied or used as the basis for the manufacture or sale of apparatus without permission.

401-08173-000 D
SHEET 1 OF 1

90-08173-XXX TABULATION

REF DES	DASH NO	REV		
T1	48V	60V	B	B

A

B

C

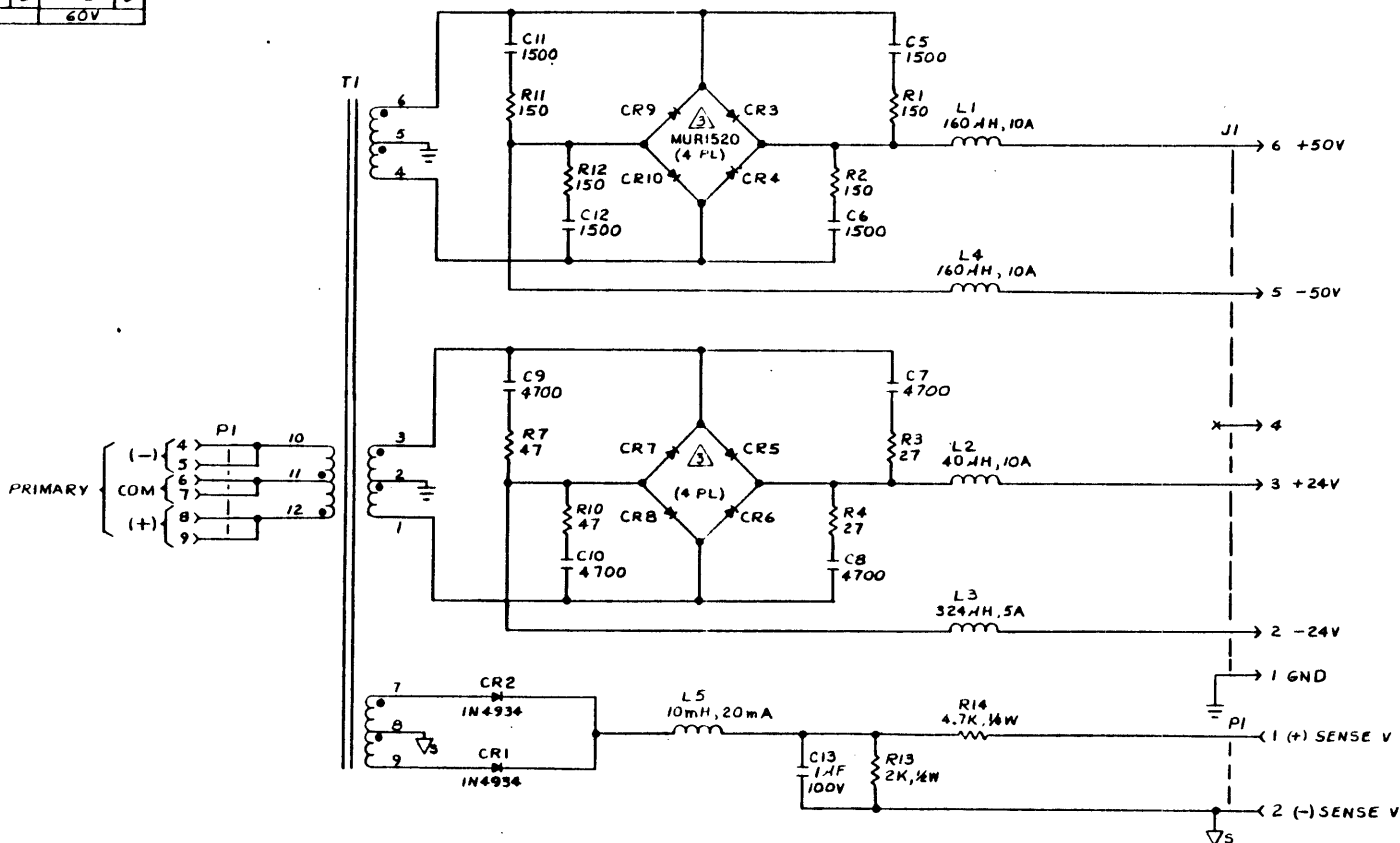

A

B

C

- 3 DIODES ARE MOUNTED ON HEATSINK 90-09376-001
2. RESISTORS ARE IN OHMS $\pm 5\%$ 2W, WW
1. CAPACITORS ARE IN PICOFARADS
- NOTES: UNLESS OTHERWISE SPECIFIED

D

REV STATUS OF SHEETS	REV	D
	SHEETS	1

LAST USED	NOT USED
C13	C1-C4
CR10	
R14	RS, G, U, D
L5	
J1	
T1	
PI	

Transformer PCB
Type 8173
Schematic Diagram

D

1 | 2 | 3 | 4 | 5 | 6 | 7 | 8

This drawing and specifications are the property of Kennedy Company and shall not be reproduced or used in the base for the manufacture or sale of apparatus without permission.

401-08174-000 F
SHEET 1 OF 1

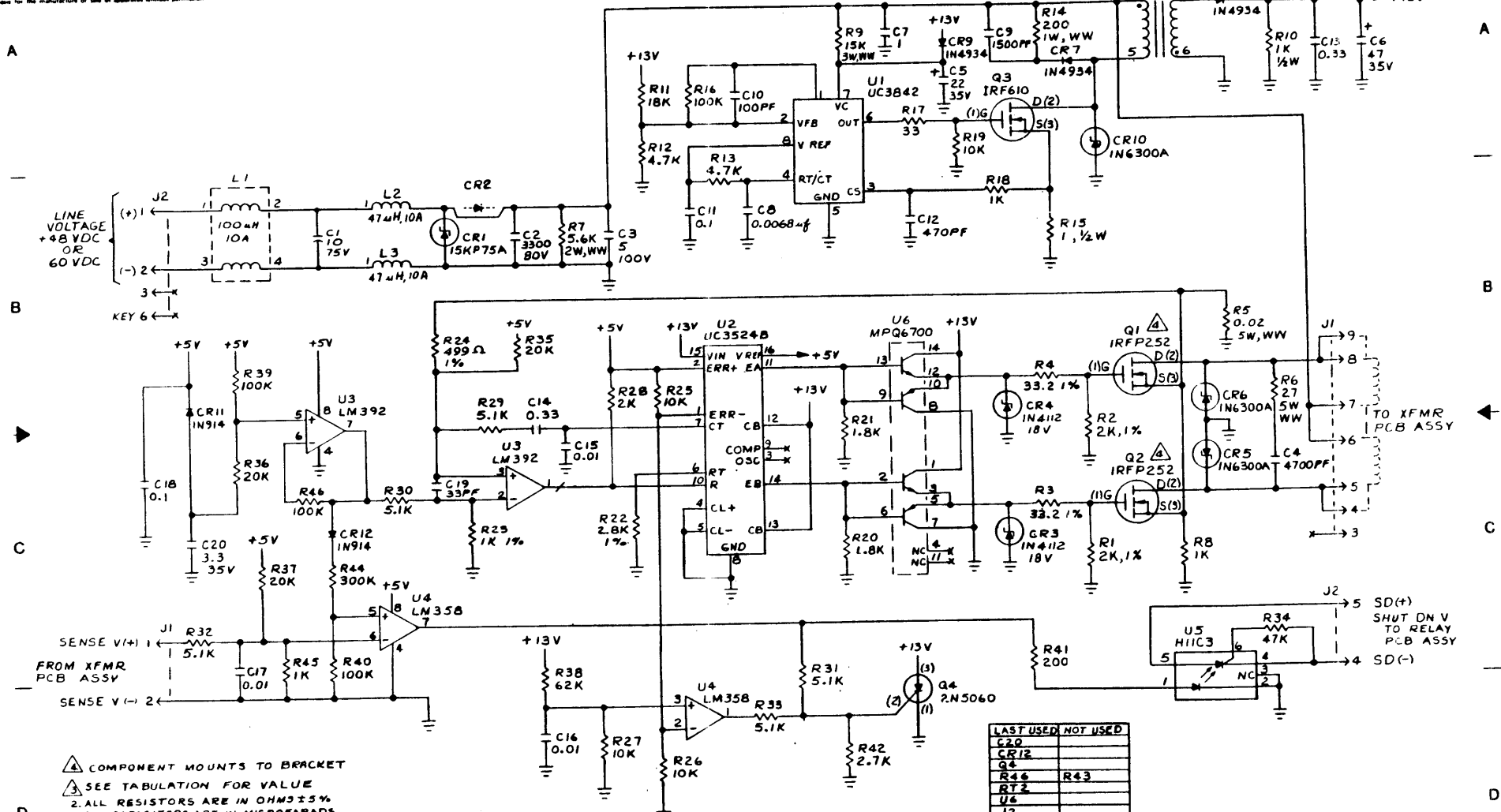

- ▲ COMPONENT MOUNTS TO BRACKET
- ▲ SEE TABULATION FOR VALUE
- 2. ALL RESISTORS ARE IN OHMS ± 5%
- 1. ALL CAPACITORS ARE IN MICROFARADS

NOTES: UNLESS OTHERWISE SPECIFIED

REV STATUS OF SHEETS	REV	F
	SHEET	1

LAST USED, NOT USED	
C20	
CR12	
Q4	
R44	R43
RT2	
U4	
J2	
L3	
T2	T1

DC Converter
Type 8174
Schematic Diagram

APPENDIX A - GLOSSARY

A.0 GENERAL

This appendix defines terms, acronyms, and abbreviations used in the manual.

Auto Speed. Operation of the Tape Drive whereby it shifts to an operating speed (50 or 100 ips) to accommodate the data throughput to/from the Host Computer.

BOT. Beginning of Tape: The section of tape near the physical beginning of tape that constitutes the approach to the beginning of the recording area. This section is marked by a photo-reflective Marker.

Block. A group of contiguous bytes considered and transmitted as a unit.

Byte. A group of eight contiguous bits that are acted on as a unit.

Character. A unit of information consisting of one byte plus a parity bit recorded as a unit.

CRC Character. Cyclic Redundancy Check Character:

In **NRZI Mode**, the next-to-last character placed in 9-track, 800-cpi, data blocks where a modified cyclic code is used. The CRC Character can be used for error detection.

Data Density. The number of single-byte characters stored per unit length of tape - usually expressed as Characters per Inch (CPI) or Bytes per Inch (BPI).

Data Access Time. Time required for tape to accelerate from a stopped state to nominal velocity and the Drive to start reading or writing data.

DDPE. Double-Density Phase-Encoded Data Format: Density is 3200 cpi which is double that of PE (Phase-Encoded Format).

EOT. End-of-Tape: A section of tape near the physical end of tape that constitutes the approach to the end of the recording area. This section is marked by a photo-reflective marker.

FM. File Mark or Tape Mark: A control block recorded on tape to separate data files from one another. A data file can consist of one or more data blocks.

Flux Transition. The change of magnetic flux from saturation in one direction to saturation in the opposite direction.

ID Burst. Density Identification Burst: A burst of data recorded near the beginning of tape, before BOT, that identifies the tape recording density as PE, or DDPE.

IPS. Inches Per Second: Parameter for expressing tape speed.

IBG. Interblock Gap: A dc-erased section of tape used to separate data blocks.

Latency. For On-The-Fly Operations, Latency refers to the time between the end of a data block and the point after which the Drive will not immediately implement the next Command before tape comes to a complete stop.

Local Operation. Operation set up or controlled from the Front Panel of the Drive with no influence from the Host Computer.

LRC Character. Longitudinal Redundancy Check Character: Used in NRZI Mode. This character is the last character in each data block. It constitutes a set of longitudinal parity bits for checking data and restoring all tracks to the de-erase polarity.

NRZI. Nonreturn-to-Zero, Change-on-ONE Data Format: Recording technique characterized by having any transition from ONE to Zero or ZERO to ONE represent a Logic ONE; all steady states (no change) represents Logic ZERO. Recording density is 800 cpi.

On-The-Fly Operation. Refers to Start/Stop Mode: Operation whereby each successive Command is issued in rapid enough sequence to keep the tape moving continuously - not stopping in IBGs.

PE. Phase-Encoded Data Format: Recording technique whereby a specific change in magnetic flux polarity represents one logic level. The opposite change in polarity represents the other logic level. Recording density is 1600 cpi.

Physical Recording Density. The number of recorded flux transitions per unit length of tape. This parameter is usually given in ftpi (Flux Transitions per Inch).

Remote Operation. Operation of the Tape Drive by the Host Computer.

Reinstruction Time. Time allowed after the Drive has written or read a data block, and before the tape comes to a complete stop, for the Host Computer to issue the next Command and continue tape motions. (Ref Figure A-1)

Reinstruction Time On Ramp. For Start/Stop Mode only - Time allowed after tape has begun to ramp down in the IBG for the Host to issue a new Command and reaccelerate tape before it comes to a complete stop in the IBG. (Ref Figure A-1)

Reposition Time. Time required for Drive to reposition tape for the next Command if the next Command was issued too late to maintain tape motion. (Ref Figure A-1)

Start/Stop Operation. Operation of the Tape Drive whereby the tape stops and starts within each Interblock Gap. Start/Stop Operation can be done at any density, but is limited to 50 ips tape speed. See On-The-Fly Operation.

Streaming Operation. Operation whereby the tape moves continuously (with some exceptions) without stopping in the Interblock Gaps. The Host Computer is allowed a full IBG period (dependent on density and tape speed) to send a valid Command (that does not change tape motion direction). If the Command is not received, within the Interblock, the Drive enters a Reposition Routine that stops the tape in an area just before the related IBG. The next Command resumes tape motion. (Ref Figure A-1)

VPE. Vertical Parity Error: Each character transmitted occupies 8 tracks for data and one track for a Parity Bit. Vertical Parity Error is one based on the parity of each character on tape.

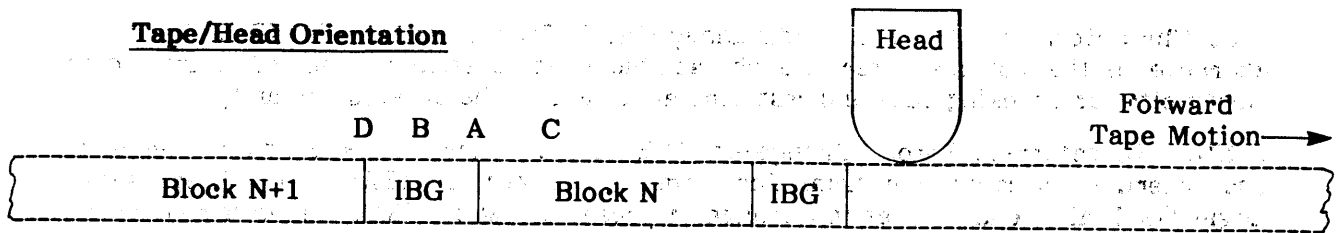

Streaming Operation

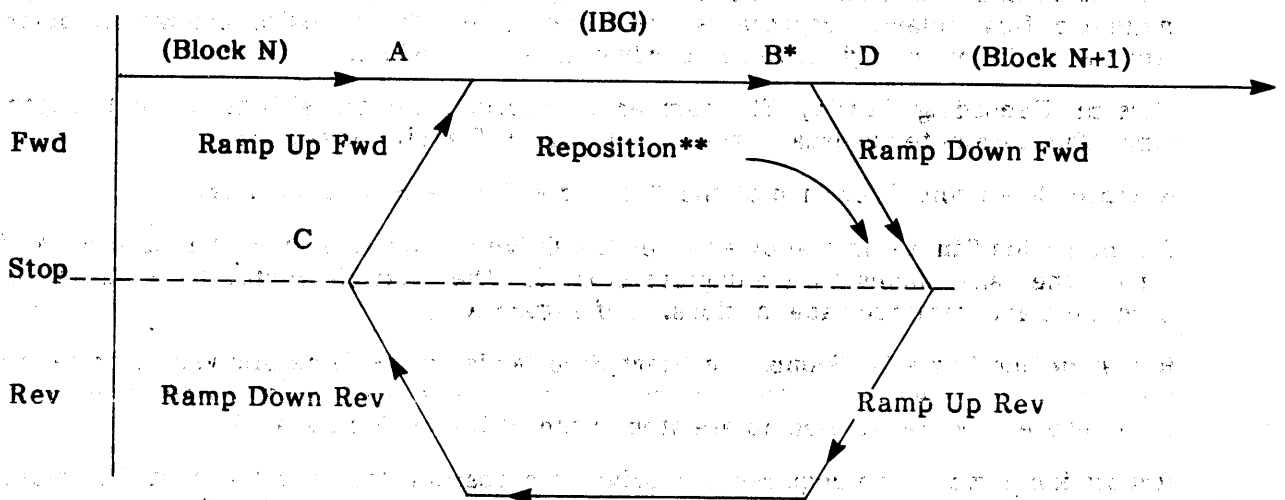

Stop/Start Operation

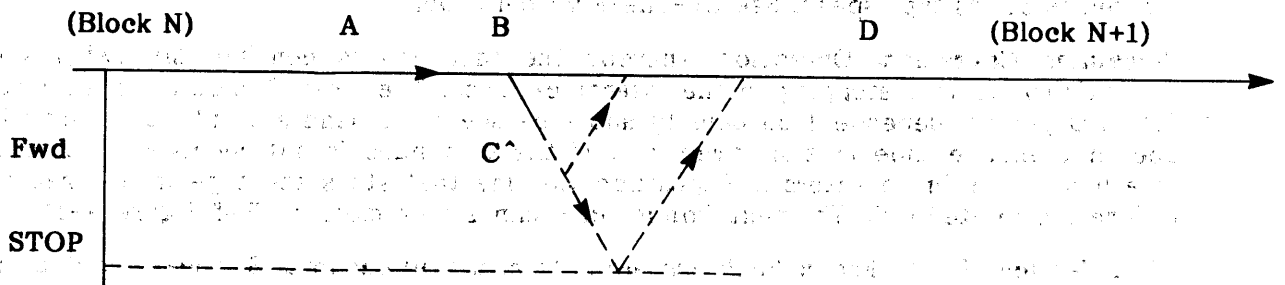

NOTE:

- * Point B is the End of Reconstruct Window, the last point where the next Command can be executed without repositioning.
- ** Repositioning occurs from B to C.
- ^ Point C is last point where new Command can be executed without ramping to a complete stop

Figure A-1. Velocity Profiles

Warranty

The Company warrants its devices against faulty workmanship or the use of defective materials (except in those cases where the materials are supplied by OEM) for a period of one year from the date of shipment to OEM, with the exception of $\frac{1}{4}$ " cartridge products which are warranted for a period of ninety (90) days.

The liability of the Company under this warranty is limited to replacing, repairing, or issuing credit (at the Company's discretion) for any devices which are returned by OEM during such period provided that (a) the Company is promptly notified in writing upon discovery of such defects by OEM; (b) the defective unit is returned to the Company, transportation charges prepaid by OEM; and (c) the Company's examination of such unit shall disclose to its satisfaction that such defects have not been caused by misuse, neglect, improper installation, repair alteration or accident.

Kennedy Company is continually striving to provide improved performance, value and reliability in its products and reserves the right to make these changes without being obligated to retrofit delivered equipment.

KENNEDY
A Division of Shugart Corporation

KENNEDY

A Division of Shugart Corporation
