

KAYPRO TECHNICAL MANUAL

JUNE 1985

Part Number 1484-E

CONTENTS

SECTION		PAGE
1.0	Introduction	
1.1	Purpose of Technical Manual	1--1
1.2	Scope of Technical Manual	1--2
1.3	Service Warning	1--2
2.0	FCC Information	2--1
3.0	Model Specifications	
3.1	KAYPRO 2	3--1
3.2	KAYPRO 2/84 and 2X	3--2
3.3	KAYPRO 4	3--3
3.4	KAYPRO 4/84	3--4
3.5	KAYPRO 4X	3--5
3.6	KAYPRO 10	3--6
3.61	KAYPRO 10 with CLOCK and MODEM	3--6.1
3.7	KAYPRO ROBIE	3--7
3.71	KAYPRO 12X	3--7.1
3.8	KAYPRO NEW 2	3--8
3.9	KAYPRO 1	3--9
4.0	ROM Revisions --- CP/M Compatibility	4--1
5.0	Chassis	
5.1	Removal/Replacement of Hood (Exc. ROBIE)	5--1
5.2	Touch-up Information	5--2
6.0	Mainboards--Troubleshooting Tips	6--1
6.1	KAYPRO 2 (81-110-n)	6--2
6.2	KAYPRO 2/4 (81-240-n)	6--8
6.3	KAYPRO 10 (81-180-n)	6--16
6.4	KAYPRO 2/84 (81-294-n)	6--26
6.5	KAYPRO 4/84 (81-184-n)	6--34
6.6	KAYPRO ROBIE (81-296-n)	6--42
6.61	KAYPRO UNIVERSAL BOARD (KAYPRO 2, 2X, 4, 4X, 10, 12X, ROBIE)	6--50
6.7	Removal/Installation Instructions	6--57
7.0	CRT Assemblies	
7.1	Descriptions and Adjustments	7--1
7.2	Video Alignment	7--3
7.3	Video Signals on KAYPRO Mainboard	7--4
7.4	Removal/Installation Instructions	7--5
8.0	Power Supplies	
8.1	Introduction	8--1
8.2	Description and 220V Configuration	8--2
8.3	Removal/Installation Instructions	8--5

CONTENTS (Continued)

SECTION		PAGE
9.0	Diskette Drives	
9.1	Introduction/Disk Drive Cleaning	9--1
9.2	Which Brand of Drive Is It?	9--2
9.3	Jumpering Diagrams	9--5
9.4	High-Density (Drivetec) Drives	9--9
9.5	Removal/Installation Instructions	9--10
10.0	Hard Disk Drives (KAYPRO 10, 12X)	
10.1	Introduction	10--1
10.2	Description	10--2
10.3	Hard Drive Configuration	10--3
10.4	Hard Drive or Floppy Drive Removal/ Installation Instructions (KAYPRO 10, 12X)	10--4
11.0	Hard Disk Controller Board (KAYPRO 10, 12X)	
11.1	Description	11--1
11.2	Removal/Installation Instructions	11--2
12.0	Interface Board (KAYPRO 10, 12X)	
12.1	Description	12--1
12.2	Removal/Installation Instructions	12--2
13.0	Keyboards	13--1
14.0	ROBIE Removal/Installation Instructions	
14.1	Chassis Covers	14--1
14.2	Diskette Drives	14--2
15.0	Troubleshooting	
15.1	Introduction	15--1
15.2	KAYPRO 2 and 4 Symptom--Fix Guides	15--2
15.3	KAYPRO 10 Symptom--Fix Guide	15--8
15.4	ROBIE Symptom--Fix Guide	15--14
15.5	KAYPRO 2/84 and 2X Symptom--Fix Guide	15--19
15.6	KAYPRO 4X Symptom--Fix Guide	15--20

CONTENTS (Continued)

SECTION		PAGE
16.0	System I/O	
16.1	Video Command Protocol	16--1
16.2	Keyboard Codes and Functions	16--3
16.3	Connector Pin-Outs	16--4
16.4	Port Addresses	16--10
17.0	Reference Section	
17.1	ASCII Chart	17--1
17.2	Memory Maps	17--2
17.3	Vendor Addresses	17--7
18.0	Suggested References	18--1
19.0	KAYPRO 16	19--1
19.1	Chassis	19--3
19.2	System Boards	19--4
19.21	IC List, KAYPRO 16	19--4.1
19.23	Board Assembly Removal	19--16
19.24	Card Removal	19--18
19.25	Mainboard Removal	19--21
19.26	Disk Controller Board Removal	19--22
19.3	CRT Assembly	19--23
19.33	CRT Removal	19--24
19.4	Power Supply	19--26
19.43	Power Supply Removal	19--29
19.5	Diskette Drives	19--31
19.53	Diskette Drive Removal	19--32
19.6	Hard Disk Drive	19--37
19.63	Hard Disk Drive Removal	19--38
19.7	Keyboard	19--41
19.8	System I/O	19--42
19.81	Parallel Printer Cable	19--42
19.84	Serial Printer Cable	19--44
19.86	Modem Cable	19--45
19.92	I/O Port Addresses	19--48
19.93	Memory Map	19--49
19.94	Switch Settings	19--50
19.95	Memory Expansion	19--52
20.0	KAYPRO 16/2	20--1

INDEX

1.0 INTRODUCTION

1.1 PURPOSE OF TECHNICAL MANUAL

This publication is intended to be a technical reference guide to be used by trained repair technicians. It will attempt to cover all dealer-serviceable sections of Kaypro computers. This manual replaces previous manuals on the subject.

The procedures and information contained in this manual assume technical expertise on the part of the reader. To avoid personal injury, do not perform any servicing unless you are a qualified service technician.

It is our desire to provide dealers with the information and support needed to expedite repairs and provide the users with the service they deserve. We encourage your comments and suggestions regarding this manual.

1.2 SCOPE OF TECHNICAL MANUAL

The information and procedures covered by this manual assume some technical knowledge on the part of the reader.

The policy of Kaypro Corporation is to repair computers to the modular level only. Even Kaypro's repair technicians do not repair switching power supplies, CRT assemblies, or disk drives. Repairs to modular components not manufactured by Kaypro Corporation (power supplies, CRT assemblies, disk drives) are NOT covered by this manual.

However, we do not discourage dealers and technicians who have the knowledge and the tools to repair to the component level from doing so, on out-of-warranty Kaypro computers.

The adjustment and removal/replacement information in this manual is organized by module type, with the exception of removal/replacement information for the KAYPRO ROBIE, which is placed in a separate section due to the differences in chassis design and hardware module placement in that machine.

1.3 SERVICE WARNING

Proper precautions must be observed to assure that components are not damaged when a unit is serviced or adapters are added to or removed from the I/O channels.

The preferred method is to have a grounding strap attached to the wrist with the drain lead connected to a common earth ground, and to have the unit positioned on a conductive grounded mat. With the above precautions observed, and the power switched off, one may insert or remove components or adapters.

If one has built up a charge, this may be felt when first contacting the aforementioned surfaces.

Failure to observe these precautions may damage the unit in such a manner as to render it unserviceable or unreliable.

2.0 FCC INFORMATION

As Kaypro keeps in step with computer technology, the models have changes which affect FCC ratings. The proper rating is affixed to the back of each computer. Contact the Kaypro Engineering Department if you need further information.

3.0 MODEL SPECIFICATIONS

3.1 KAYPRO 2 SPECIFICATIONS

CPU	Z-80, 2.5 MHz
RAM	64K bytes
MAINBOARD	81-110-n or 81-240-n series.
DISK STORAGE	Two 5-1/4 inch, double-density, single-sided, floppy disk drives, providing 191K bytes of storage per diskette.
KEYBOARD	Detachable, 72 key typewriter style keyboard with 18 programmable keys.
VIDEO SCREEN	Non-glare, 9-inch, green phosphor screen with a 25 row x 80 column display.
I/O CONNECTIONS	One "Centronics"-type parallel port, one RS-232C serial port.

3.2 KAYPRO 2/84 and 2X SPECIFICATIONS

CPU	Z80-A, 4.0 MHz
RAM	64K bytes
MAINBOARD	81-294-n series.
DISK STORAGE (Kaypro 2/84)	Two 5-1/4 inch double-density, single-sided, floppy disk drives, providing 191K bytes of storage per diskette.
DISK STORAGE (Kaypro 2X)	Two 5-1/4 inch double-density, double-sided, floppy disk drives, providing 390K bytes of storage per diskette.
KEYBOARD	Detachable, 72 key typewriter style keyboard with 18 programmable keys.
VIDEO SCREEN	Non-glare, 9-inch, green phosphor screen with a 25 row x 80 column display.
I/O CONNECTIONS	One "Centronics"-type parallel port, two RS-232C serial ports.

3.3 KAYPRO 4 SPECIFICATIONS

CPU	Z-80, 2.5 MHz
RAM	64K bytes
MAINBOARD	81-240-n series.
DISK STORAGE	Two 5-1/4 inch double-density, double-sided, floppy disk drives, providing 390K bytes of storage per diskette.
KEYBOARD	Detachable, 72 key typewriter style keyboard with 18 programmable keys.
VIDEO SCREEN	Non-glare, 9-inch, green phosphor screen with a 25 row x 80 column display.
I/O CONNECTIONS	One "Centronics"-type parallel port, one RS-232C serial port.

3.4 KAYPRO 4/84 SPECIFICATIONS

CPU	Z-80A, 4.0 MHz
RAM	64K bytes
MAINBOARD	81-184-n series.
DISK STORAGE	Two double-density, double-sided, floppy disk drives, providing 390K bytes of storage per diskette.
KEYBOARD	Detachable, 72 key typewriter style keyboard with 18 programmable keys.
VIDEO SCREEN	Non-glare, 9-inch green phosphor screen with a 25 row x 80 column display.
I/O CONNECTIONS	One "Centronics"-type parallel port, two RS-232C serial ports, one RJ11C modular telephone jack.
MODEM	Built-in, 300-baud modem, with Bell System 103 compatibility. Uses Texas Instruments TMS99531/TMS99532.
REAL-TIME CLOCK	Built-in real-time clock. Uses National MM58167.

3.5 KAYPRO 4X SPECIFICATIONS

CPU	Z-80A, 4.0 MHz
RAM	64K bytes
MAINBOARD	81-296-n series.
DISK STORAGE	Two 5-1/4 inch, high-density, double-sided, floppy disk drives providing 2.6M bytes of storage per diskette.
KEYBOARD	Detachable, 72 key typewriter style keyboard with 18 programmable keys.
VIDEO SCREEN	Non-glare, 9-inch, green phosphor screen with a 25 row x 80 column display.
I/O CONNECTIONS	One "Centronics"-type parallel port, two RS-232C serial ports, one RJ11C modular telephone jack.
MODEM	Built-in, 300-baud modem, with Bell System 103 compatibility. Uses Texas Instruments TMS99531/TMS99532.
REAL-TIME CLOCK	Built-in real-time clock. Uses National MM58167.

3.6 KAYPRO 10 SPECIFICATIONS

CPU	Z80A, 4.0 MHz
RAM	64K bytes
MAINBOARD	81-180-n series.
DISK STORAGE	One 5-1/4 inch double-density, double-sided, floppy disk drive providing 390K bytes of storage per diskette. One hard disk drive providing 10M bytes of storage.
KEYBOARD	Detachable, 72 key typewriter style keyboard with 18 programmable keys.
VIDEO SCREEN	Non-glare, 9-inch, green phosphor screen with a 25 row x 80 column display.
I/O CONNECTIONS	One "Centronics"-type parallel port, two RS-232C serial ports.

3.61 KAYPRO 10 with CLOCK and MODEM SPECIFICATIONS

CPU	Z80A, 4.0 MHz
RAM	64K bytes
MAINBOARD	81-583-n series.
DISK STORAGE	One 5-1/4 inch double-density, double-sided, floppy disk drive providing 390K bytes of storage per diskette. One hard disk drive providing 10M bytes of storage.
KEYBOARD	Detachable, 72 key typewriter style keyboard with 18 programmable keys.
VIDEO SCREEN	Non-glare, 9-inch, green phosphor screen with a 25 row x 80 column display.
I/O CONNECTIONS	One "Centronics"-type parallel port, two RS-232C serial ports.
MODEM	Built-in, 300 baud modem, with Bell System 103 compatibility. Uses Texas Instruments TMS99531/TMS99532.
REAL-TIME CLOCK	Built-in real-time clock. Uses National MM58167.

3.7 KAYPRO ROBE SPECIFICATIONS

CPU	Z80A, 4.0 MHz
RAM	64K bytes
MAINBOARD	81-296-n series.
DISK STORAGE	Two 5-1/4 inch, high-density, double-sided, floppy disk drives providing 2.6M bytes of storage per diskette.
KEYBOARD	Detachable, 72 key typewriter style keyboard with 18 programmable keys.
VIDEO SCREEN	Non-glare, 9-inch, green phosphor screen with a 25 row x 80 column display.
I/O CONNECTIONS	One "Centronics" type parallel port, two RS232C serial ports, one RJ11C modular telephone jack.
MODEM	Built-in, 300-baud modem, with Bell System 103 compatibility. Uses Texas Instruments TMS99531/TMS99532.
REAL-TIME CLOCK	Built-in real-time clock. Uses National MM58167.

3.71 KAYPRO 12X SPECIFICATIONS

CPU	Z80A, 4.0 MHz
RAM	64K bytes
MAINBOARD	81-471-n series.
DISK STORAGE	One 5-1/4 inch high-density, double-sided, floppy disk drive providing 2.6M bytes of storage per diskette. One hard disk drive providing 10M bytes of storage.
KEYBOARD	Detachable, 72 key typewriter style keyboard with 18 programmable keys.
VIDEO SCREEN	Non-glare, 9-inch, green phosphor screen with a 25 row x 80 column display.
I/O CONNECTIONS	One "Centronics"-type parallel port, two RS-232C serial ports.
MODEM	Built-in, 300 baud modem, with Bell System 103 compatibility. Uses Texas Instruments TMS99531/TMS99532.
REAL-TIME CLOCK	Built-in real-time clock. Uses National MM58167.

3.8 KAYPRO NEW 2 SPECIFICATIONS

CPU	Z-80A, 4.0 MHz
RAM	64K bytes
MAINBOARD	81-294-n series.
DISK STORAGE	One 5-1/4 inch double-density, double-sided, floppy disk drive, providing 390K bytes of storage per diskette.
KEYBOARD	Detachable, 72 key typewriter style keyboard with 18 programmable keys.
VIDEO SCREEN	Non-glare, 9-inch, green phosphor screen with a 25 row x 80 column display.
I/O CONNECTIONS	One "Centronics"-type parallel port, two RS-232C serial ports.

3.9 KAYPRO 1 SPECIFICATIONS

CPU	Z80A, 4.0 MHz
RAM	64K bytes
MAINBOARD	81-809-n series.
DISK STORAGE	Two 5-1/4 inch double-density, double-sided, floppy disk drive providing 390K bytes of storage per diskette.
KEYBOARD	Detachable, 72 key typewriter style keyboard with 18 programmable keys.
VIDEO SCREEN	Non-glare, 9-inch, green phosphor screen with a 25 row x 80 column display.
I/O CONNECTIONS	One "Centronics"-type parallel port, two RS-232C serial ports.

4.0 KAYPRO ROM REVISION—CP/M VERSION COMPATIBILITY

MODEL NAME	CP/M VERSION	MAINBOARD	ROM REVISION
2/83	2.2f	81-110	81-149-C
4/83	2.2f	81-240	81-232-A
4/83 + 88	2.2f	81-240	81-232-A
2/84	2.2g	81-294	81-292-A
4/84	2.2g	81-184	81-292-A
4/84 + 88	2.2g	81-184	81-292-A
2X	2.2g 2.2h	81-294	81-292-A
4X	2.2g 2.2h	81-297	81-326-E
ROBIE	2.2g 2.2h	81-296	81-478-A
10	2.2g 2.2h	81-180	81-302-C
2X W/MODEM and CLOCK	2.2u1	81-580	81-478-A
10 W/MODEM and CLOCK	2.2u1	81-582	81-478-A
NEW 2	2.2u1	81-294	81-478-A
1	2.2u1	81-294	81-478-A

5.0 CHASSIS

5.1 CHASSIS HOOD REMOVAL (EXCEPT KAYPRO ROBIE)

1. Turn off the machine.
2. Disconnect AC power by unplugging the power cord from wall outlet.
3. Remove the ten screws from the chassis hood; there are two on top and four on each side.
4. Remove the hood from the chassis.

CHASSIS HOOD REPLACEMENT

1. Lower the hood onto the unit.
2. Align the two holes on top of the hood with those on top of the chassis.
3. Insert the two flat-head screws into the holes on the top of the chassis and start them, but do not tighten them yet.
4. Insert the eight round-head screws, four on each side, and start them.
5. Tighten each screw securely.

5.2 TOUCH-UP INFORMATION

Kaypro Corporation has small amounts of touch-up paint for Kaypro hoods and chassis available to the dealers. Contact the Hardware Technical Support personnel to obtain this paint.

Occasionally a customer's computer will have scratches on the hood or chassis. A small amount of rubbing compound, when carefully applied, will often smooth out very small scratches on a hood or chassis. Should painting be necessary, there are two sizes of sable paintbrushes to have on hand: size 00 and size 000. These brushes are available at any art supply store.

6.0 MAINBOARDS

The following sections contain schematics, chip layout diagrams, and IC lists (by U-number) for Kaypro mainboards. This is not intended to be a theory of operation, but rather an aid in locating possible problems on a mainboard.

Consult an appropriate databook (TTL, Zilog, etc.) if you need to find out the internal workings of a particular IC.

MAINBOARD TROUBLESHOOTING TIPS:

A blank EPROM can be used to help troubleshoot Kaypro mainboards of series 81-110, 81-240, and 81-180. The appropriate model of EPROM (2732, 2716, etc) allows a quick check of the board. It will usually force the data and address lines to toggle at approximately the same amplitude, allowing the technician to use a scope to spot affected lines.

If the video display does not show a screen filled with alternating "9"s and apostrophes, you have a problem in the video RAM or associated circuitry.

You can check the main RAM and associated circuitry quickly with a scope by looking at pin 14 on each of the RAM chips. The following pattern should be observed:

For the 81-240 board:

U20 (D7)	low
U21 (D6)	low
U22 (D5)	toggle
U23 (D4)	toggle
U24 (D3)	toggle
U25 (D2)	low
U26 (D1)	low
U27 (D0)	toggle

The U-numbers of the main RAM chips will vary depending on which mainboard you have, but the pattern will be the same.

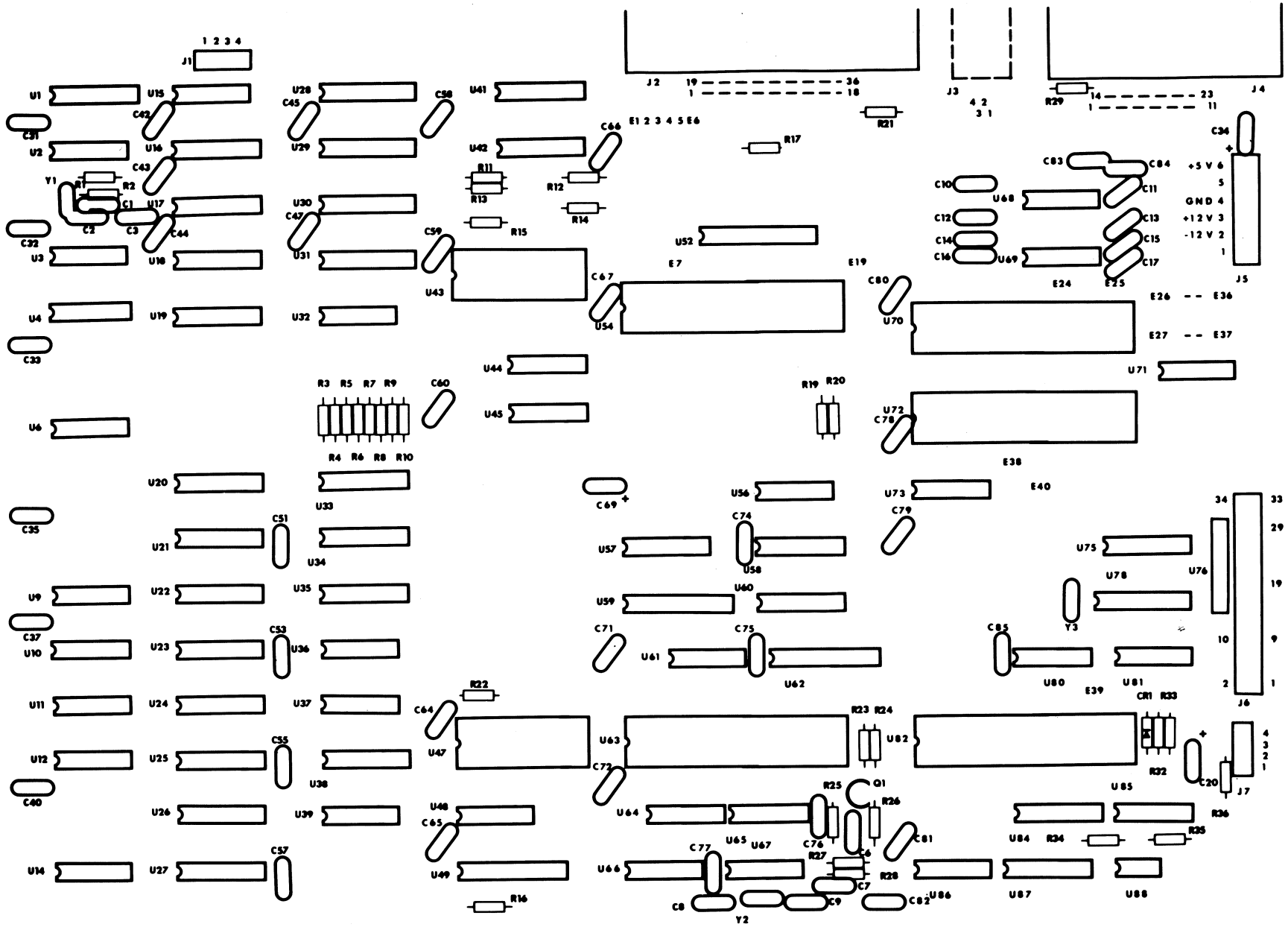

6-2

IC LIST, KAYPRO 2 (81-110-n)

Reference Designation		Description
U1	74LS161	4-bit counter
U2, U67*	74HCU04	Hex inverter, CMOS
U3	74LS290	decade counter
U4	74LS10	Tri NAND gates
U6, U11	74LS393	Dual binary counter
U9, U80	74LS08	Quad AND gates
U10, U61	73LS32	Quad OR Gates
U12, U14, U32	74LS74	Dual "D" flip-flop
U15, U39	74LS00	Quad NAND Gates
U16 through U19	74LS157	Quad 2/1 MUX
U20 through U27	MQM6665	(or equivalent) 64K x 1 RAM
U28 through U31	2114	1K x 4 RAM
U33, U34	74157	Quad 2/1 MUX
U35, U38	8216	Quad Bi-directional MUX
U36	74LS20	Dual NAND gates
U37, U56, U85	74LS02	Quad NOR gates
U41	74S151	8/1 MUX
U42	74LS174	Hex "D" flip-flop
U43	81-146	Character generator EPROM
U44, U45, U64, U65	74LS243	Quad bus trans
U47	81-149	Boot EPROM
U48, U73	74LS04	Hex inverter
U49, U52, U62	74LS241	Octal buffer
U54, U72	Z80 PIO	
U57, U58, U60	74LS138	3/8 MUX
U59	74LS373	Octal "D" latch
U63	Z80 CPU	
U66	74164	8-bit shift register
U68	1488	Quad line driver (OUT)
U69	1489	Quad SCHMITT line receiver (IN)
U70	Z80 SIO	
U71	74S04	Hex inverter
U78	8116	Dual programmable baud rate generator
U81	7406	Hex inverter, open collector
U82	FD1793	Floppy disk controller
U84	74LS195	4-bit shift register
U86	74LS293	4-bit binary counter
U87	74LS390	Dual decade counter
U88	FDC9216	Data separator

*NOTE: THERE ARE SOME VERSIONS OF THE 81-110 BOARD ON WHICH U2 AND U67 ARE NOT CMOS IC.S BUT ARE NORMAL TTL IC.S. READ THE NUMBER ON THE IC TO BE SURE.

SCOPE SIGNALS TO AID IN TROUBLESHOOTING (81-110-n)

The examples of correct signals shown below do not represent all of the signals on a Kaypro mainboard, since most signals will be simple high-low toggles. A group of video signals (CC0 through CC3) are included as illustrations of the timing relationships between the various video signals. Note that only one of the I/O signals on U57 will be low at any given time.

State of the machine: The door of drive A is open; the machine is waiting to boot.

The signal measurements were made using a Tektronix oscilloscope, model 2213. It has a bandwidth of DC-60 MHz, sensitivity of 2mV/cm, a sweep delay of 0.1 microseconds to 1 second, and a graticule display measuring 8 x 10 cm.

Signal M1 from pin 27 of the CPU (U63) was triggered on. This signal is shown in the top half of each display and was channel 1. Ground for the signals shown on channel 2 was established at first graticule line above the bottom of the display.

Each square of the representation is the equivalent of one square cm on the graticule. The scope was set for 2V/div. for all figures, and was set for .5 micro-secs/div. for all figures EXCEPT figure 6, which was taken using 1 micro-secs/div.

Figure 1: Pin 6 of U63, 2.5MHz clock signal.

Figure 2: Pin 24 of U82, 1MHz clock signal.

Figure 3: Pin 3 of U6, CC0.

Figure 4: Pin 4 of U6, CC1.

Figure 5: Pin 5 of U6, CC2.

Figure 6: Pin 6 of U6, CC3.

FIGURE 1

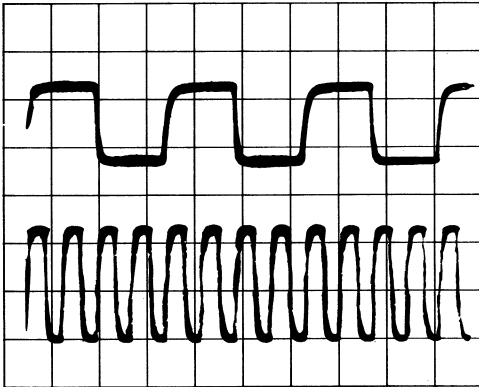

FIGURE 2

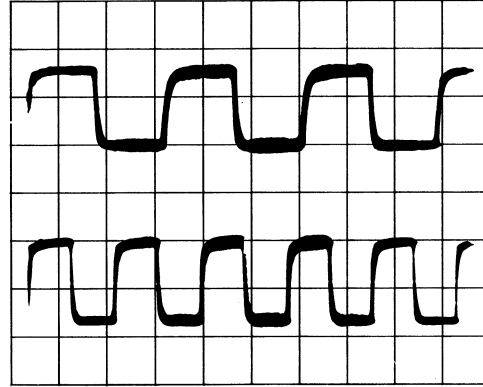

FIGURE 3

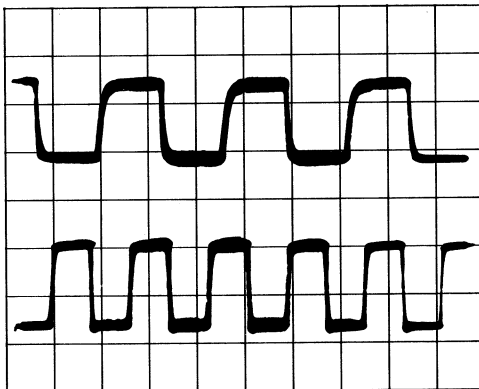

FIGURE 4

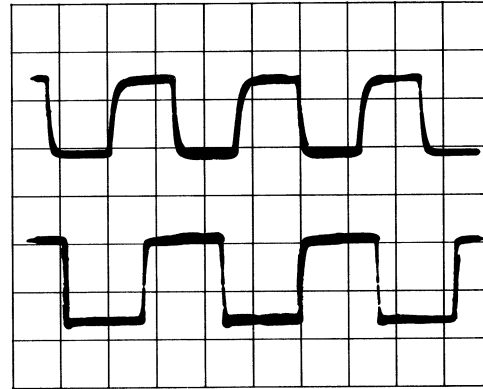

FIGURE 5

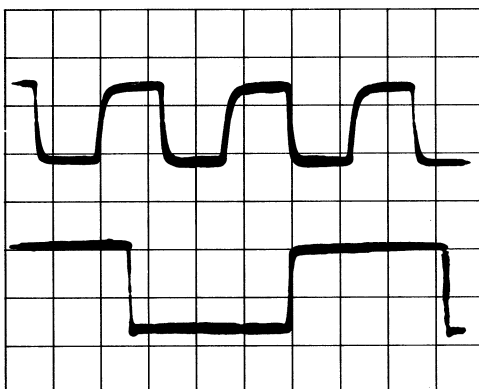
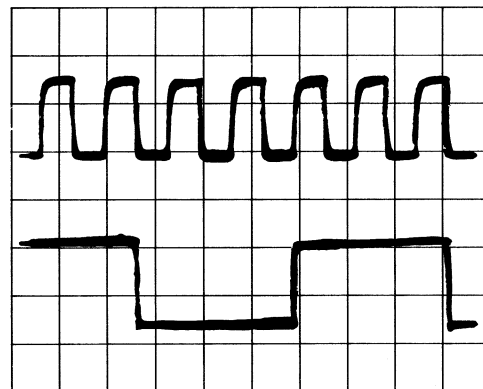
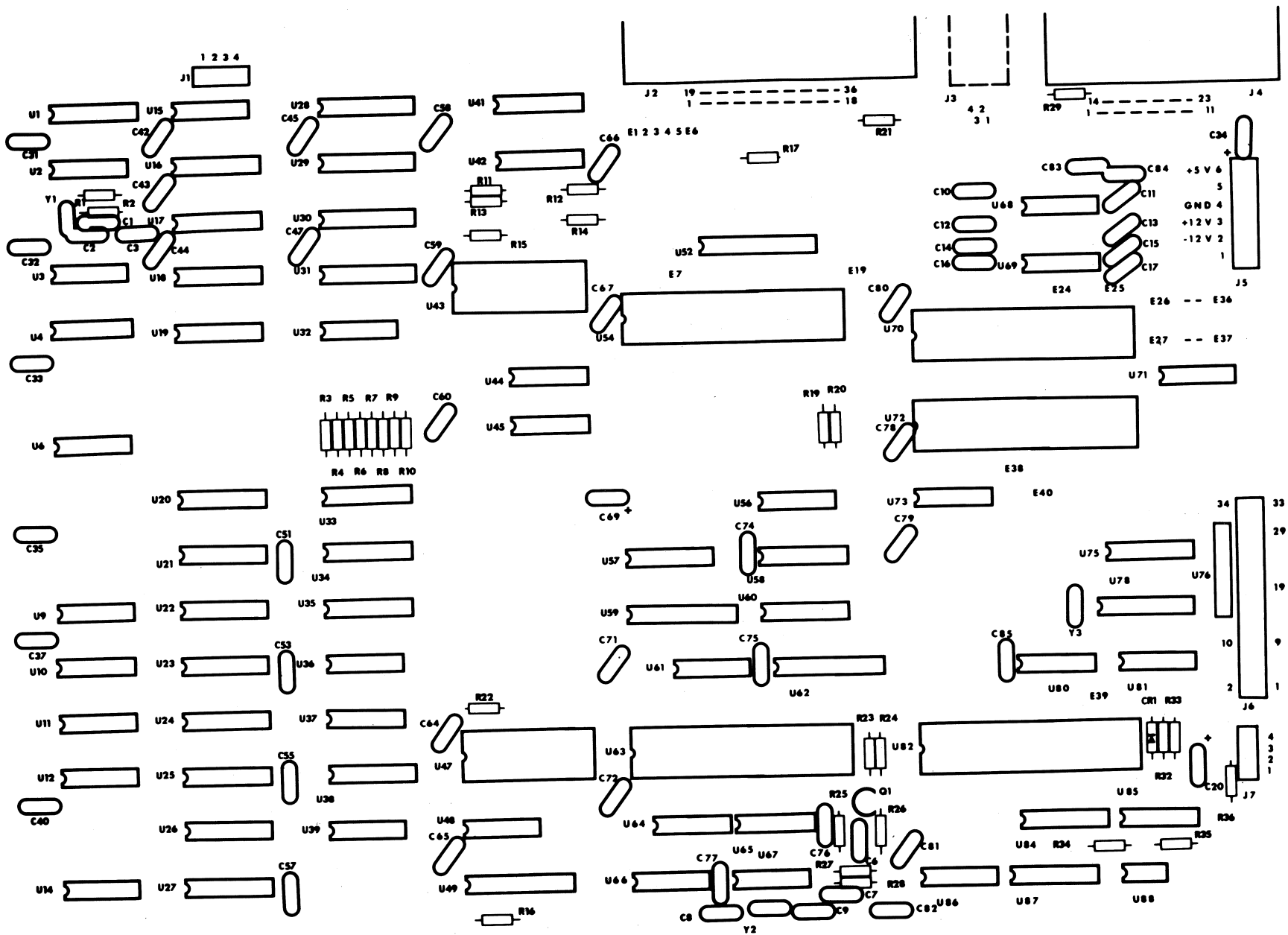

FIGURE 6



SIGNAL LOCATIONS ON MAINBOARD 81-110-n

<u>SIGNAL</u>	<u>IC</u> <u>LOCATION</u>	<u>PIN NO.</u>
CPU SIGNALS		
2.5 MHz	U 63	6
MREQB	U 62	16
RDB	U 62	5
WRB	U 62	14
MEMORY SIGNALS		
RAS	U 39	11
CAS	U 66	5
MUXC	U 66	4
VIDEO CLOCK SIGNALS		
CLOCK, Y1	U 2	8
CC0	U 6	3
CC1	U 6	4
CC2	U 6	5
CC3	U 6	6



IC LIST, KAYPRO 2/4 (81-240-n)

Reference Designation		Description
U1	74LS161	4-bit counter
U2, U67	74HCU04	Hex inverter, CMOS
U3	74LS290	Decade counter
U4	74LS10	Tri NAND gates
U6, U11	74LS393	Dual binary counter
U9, U80	74LS08	Quad AND gates
U10, U61	73LS32	Quad OR Gates
U12, U14, U32	74LS74	Dual "D" flip-flop
U15, U39	74LS00	Quad NAND Gates
U16 through U19	74LS157	Quad 2/1 MUX
U20 through U27	MCM6665	(or equivalent) 64K x 1 RAM
U28 through U31	2114	1K x 4 RAM
U33, U34	74157	Quad 2/1 MUX
U35, U38	8216	Quad Bi-directional MUX
U36	74LS20	Dual NAND gates
U37, U56, U85	74LS02	Quad NOR gates
U41	74S151	8/1 MUX
U42	74LS174	Hex "D" flip-flop
U43	81-146-n	Character generator EPROM
U44, U45, U64, U65	74LS243	Quad bus trans
U47	81-232-n	Boot EPROM
U48, U73	74LS04	Hex inverter
U49, U52, U62	74LS241	Octal buffer
U54, U72	Z80 PIO	
U57, U58, U60	74LS138	3/8 MUX
U59	74LS373	Octal "D" latch
U63	Z80 CPU	
U66	74164	8-bit shift register
U68	MC1488	Quad line driver (OUT)
U69	MC1489	Quad SCHMITT line receiver (IN)
U70	Z80 SIO	
U71	74S04	Hex inverter
U78	8116	Dual programmable baud rate generator
U81	7406	Hex inverter, open collector
U82	1793	Floppy disk controller
U84	74LS195	4-bit shift register
U86	74LS293	4-bit binary counter
U87	74LS390	Dual decade counter
U88	FDC9216	Data separator

SCOPE SIGNALS FOR TROUBLESHOOTING 81-240-n

The examples of correct signals shown below do not represent all of the signals on a Kaypro mainboard, since most signals will be simple high-low toggles. A group of video signals (CC0 through CC3) are included as illustrations of the timing relationships between the various video signals. Note that only one of the I/O signals on U57 will be low at any given time.

State of the machine: with a blank, 2732, EPROM inserted in place of normal EPROM at location U 47. The door of drive A is open; the machine is waiting to boot.

The signal measurements were made using a Tektronix oscilloscope, model 2213. It has a bandwidth of DC-60 MHz, sensitivity of 2mV/cm, a sweep delay of 0.1 microseconds to 1 second, and a graticule display measuring 8 x 10 cm.

Signal M1 from pin 27 of the CPU (U63) was triggered on. This signal is shown in the top half of each display and was channel 1. Ground for the signals shown on channel 2 was established at first graticule line above the bottom of the display.

Each square of the representation is the equivalent of one square cm on the graticule. The scope was set for 2V/div. for all figures, and was set for .5 micro-secs/div. for all figures EXCEPT figure 6, which was taken using 1 micro-secs/div.

Figure 1: Pin 6 of U63, 2.5MHz clock signal.

Figure 2: Pin 24 of U82, 1MHz clock signal.

Figure 3: Pin 3 of U6, CC0.

Figure 4: Pin 4 of U6, CC1.

Figure 5: Pin 5 of U6, CC2.

Figure 6: Pin 6 of U6, CC3.

FIGURE 1

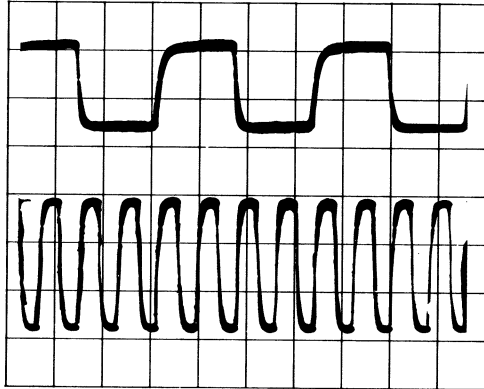

FIGURE 2

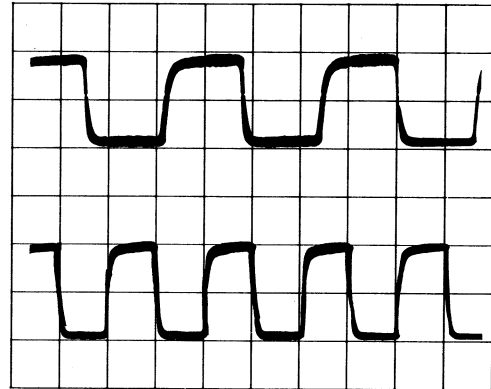

FIGURE 3

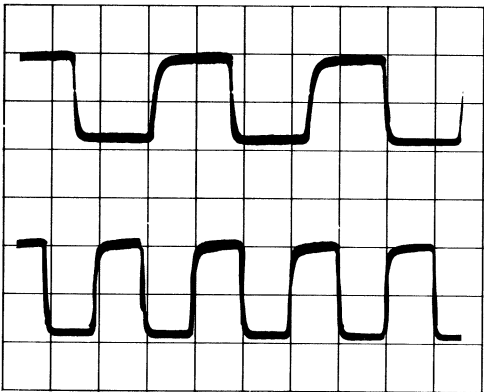

FIGURE 4

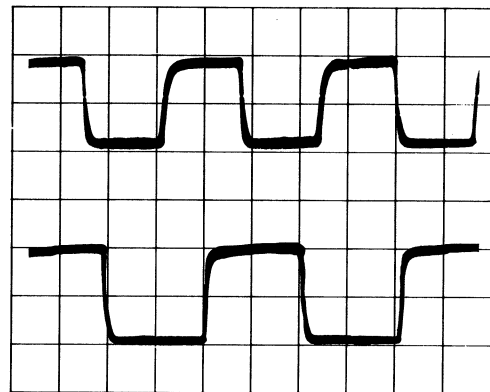

FIGURE 5

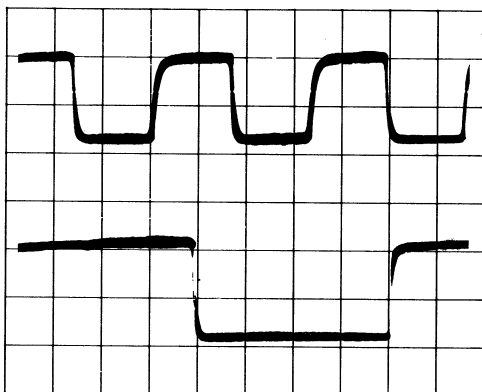
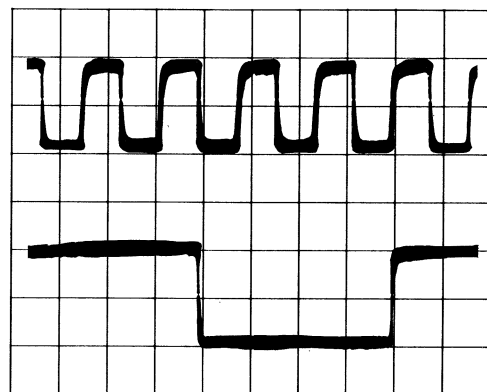

FIGURE 6



SIGNAL LOCATIONS, 81-240-n

<u>SIGNAL</u>	<u>IC</u> <u>LOCATION</u>	<u>PIN NO.</u>
CPU SIGNALS		
CPU clock	U 67	6
1 MHz	U 87	13
2 MHz	U 87	3
MREQB	U 62	16
RDB	U 62	5
MIR (reference)		
MEMORY SIGNALS		
RAS	U 39	11
CAS	U 66	5
MUXC	U 66	4
VIDEO CLOCK SIGNALS		
CLOCK, Y1	U 2	8
CC0	U 6	3
CC1	U 6	4
CC2	U 6	5
CC3	U 6	6

REVISIONS					
ZONE	LTR.	EFFECT.	DESCRIPTION	DATE	APPROV.
B			REDRAWN; WAS SH. BY FAX (T-518E)	11-1-82	R-W-J
C			LIST PIN 7 WAS SET TO 0. LOTS PIN 10 WAS REVERSED. D48 / D78 LABELS ON U15 WERE REVERSED.	12-28-82	R-W-J
D			2 MHz WAS CONNECTED TO PINS U87	4-22-83	R-W-J

6-13

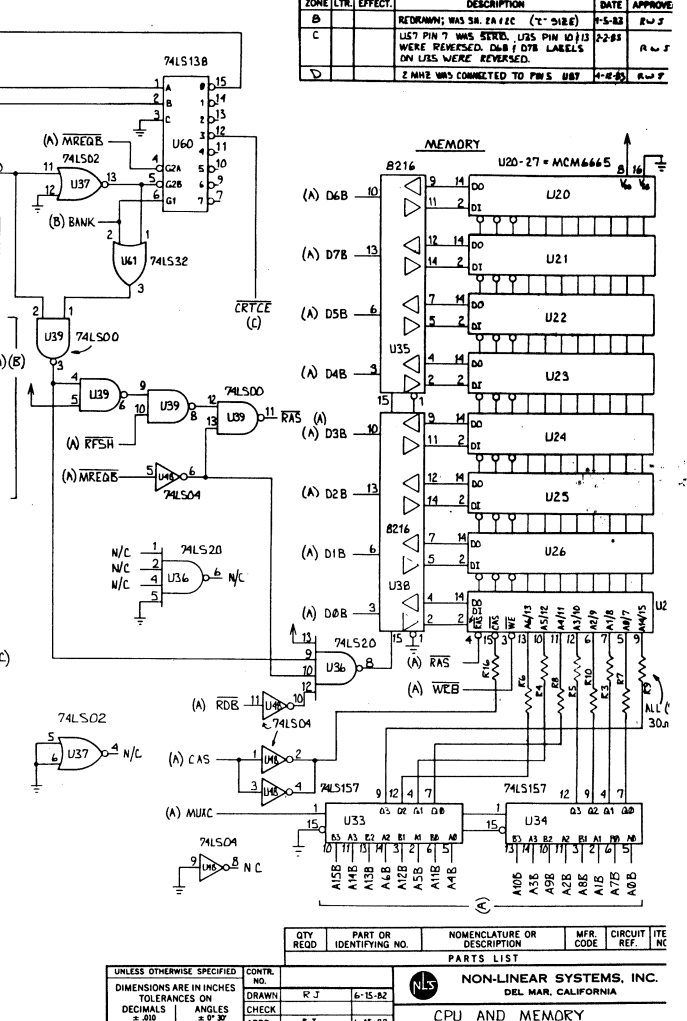
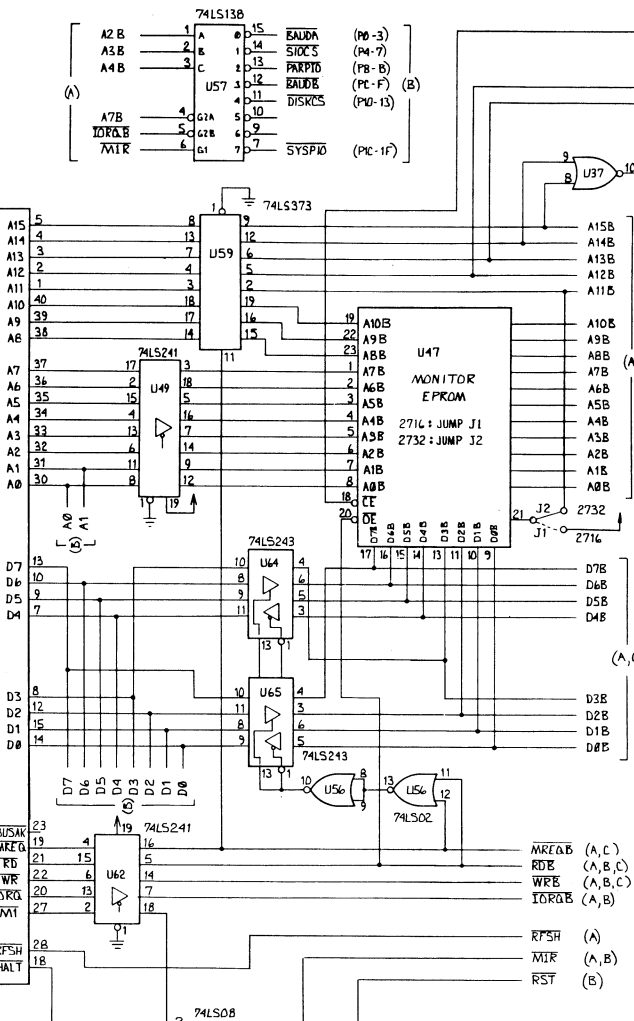
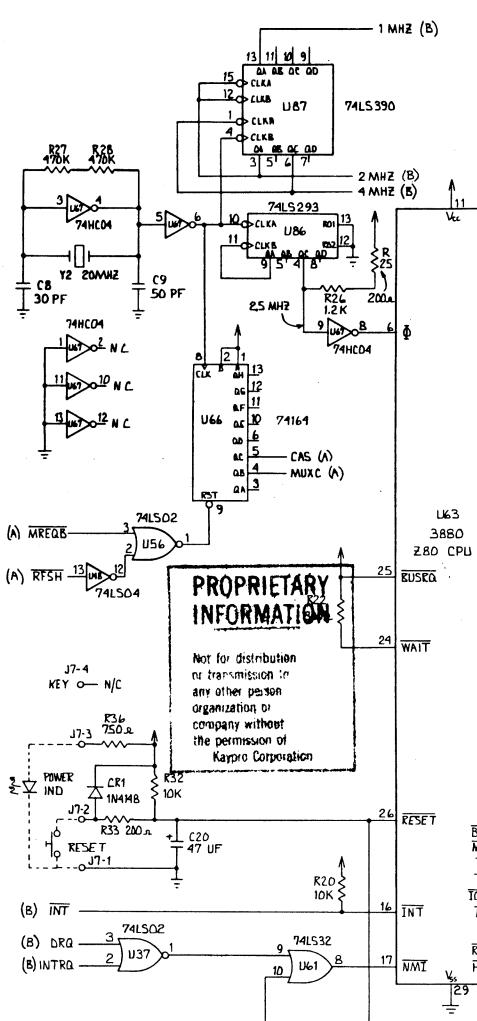
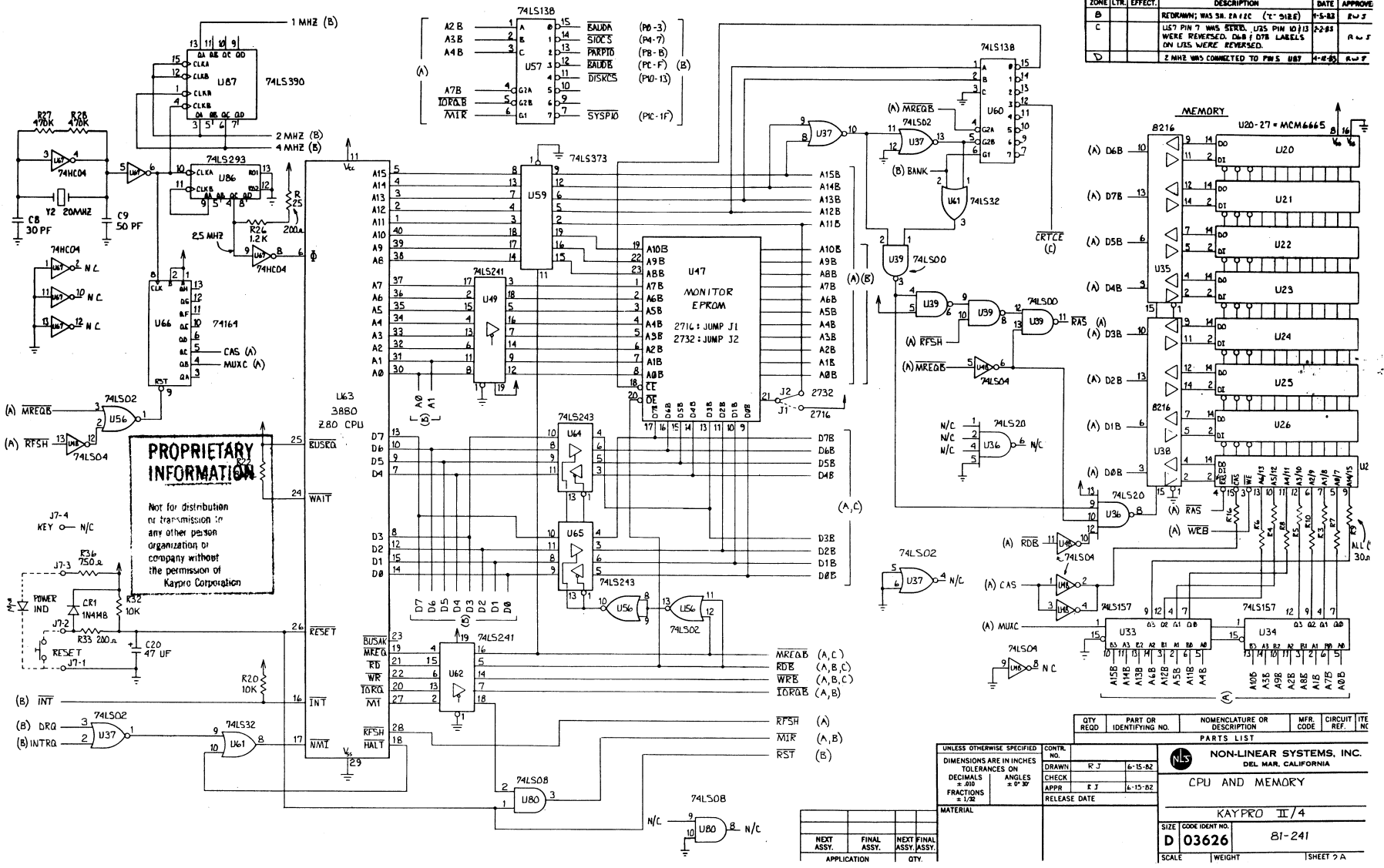

QTY REQD.	PART OR IDENTIFYING NO.	NOMENCLATURE OR DESCRIPTION	MFR. CODE	CIRCUIT REF. NO.
		NON-LINEAR SYSTEMS, INC. DEL MAR, CALIFORNIA		
		CPU AND MEMORY		
		KAYPRO II/4		
		SIZE: 03626	81-241	
		SCALE: _____	WEIGHT: _____	SHEET: 2 A

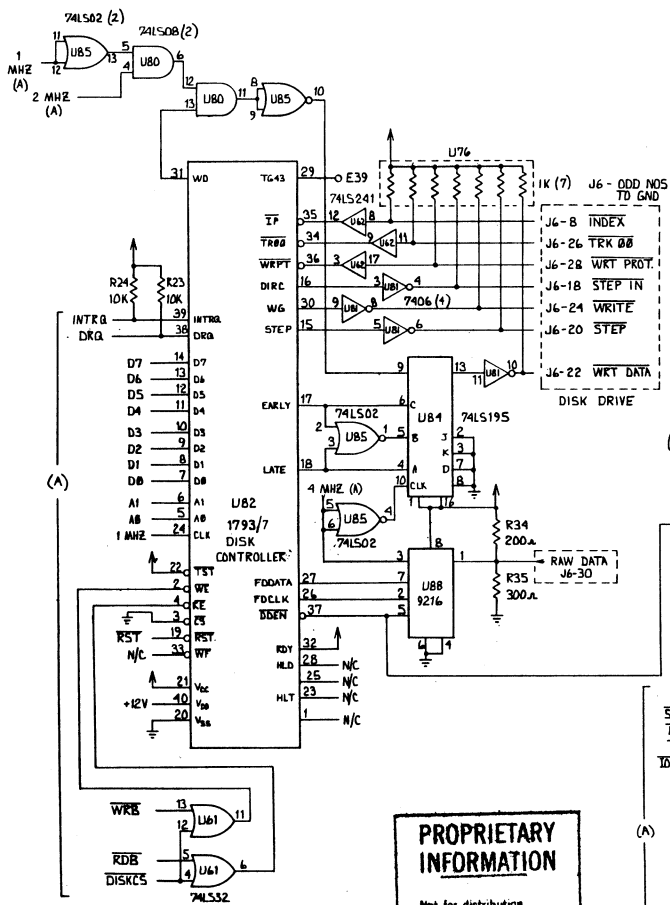

PROPRIETARY INFORMATION

Not for distribution or transmission to any other person organization or company without the permission of Kaypro Corporation

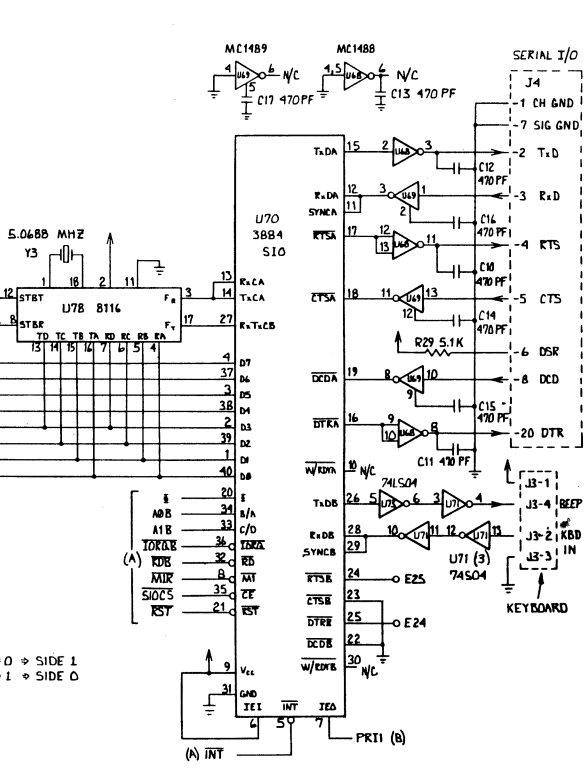
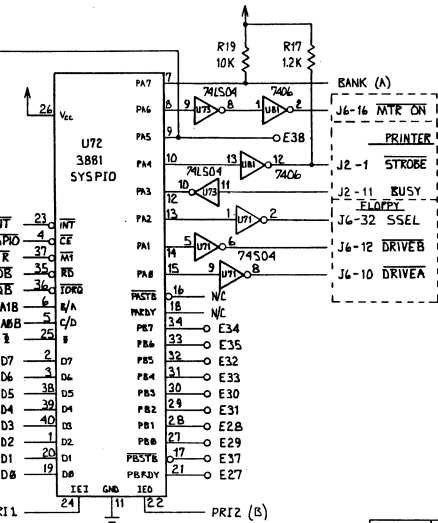
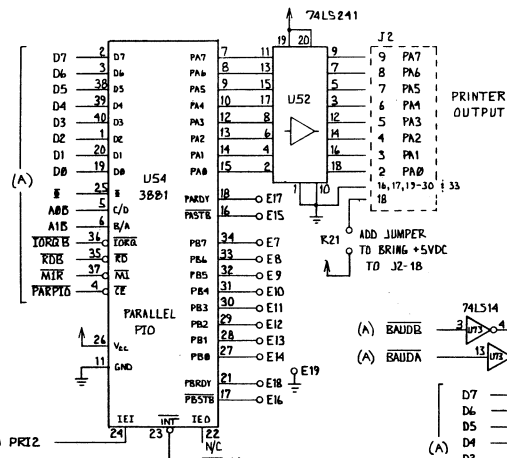

REVISIONS					
ZONE	LTR.	EFFECT.	DESCRIPTION	DATE	APPROVED
B			REDRAWN; WAS SH 201 RE ('C' SIZE)	1-5-83	R W J
C			UB5 PIN 4 HAD NO BUBBLE. U70 PIN 35 WAS SET TO GND. ADDED GND INFO ON J2, J6	2-2-83	R W J
D			LABELS ON PIN 5, 13 REVERSED (U4) U7, PIN 3 WAS LABELED F, 7 PIN 17, F ₂	5-9-83	R W J
				7-20-83	R W J

QTY RECD	PART OR IDENTIFYING NO.	NOMENCLATURE OR DESCRIPTION	MFR. CODE	CIRCUIT REF.	ITEM NO.
PARTS LIST					
NON-LINEAR SYSTEMS, INC. DEL MAR, CALIFORNIA					
I/O AND DISK CONTROLLER					
KAYPRO II / 4					
SIZE	CODE IDENT. NO.				
D	03626	B1-241			
SCALE	WEIGHT	SHEET		26	

UNLESS OTHERWISE SPECIFIED	CONTR. NO.	DATE
DIMENSIONS ARE IN INCHES	R J	5-21-82
TOLERANCES ON DECIMALS = .005	CHECK	
FRACTIONS = 1/32	APPR	5-21-82
ANGLES = 30°	RELEASE DATE	

ZONE	LTR.	EFFECT	DESCRIPTION	DATE	APR.
B			REWORK: WAS SH 28 (C-MEE)	7-8-82	BR

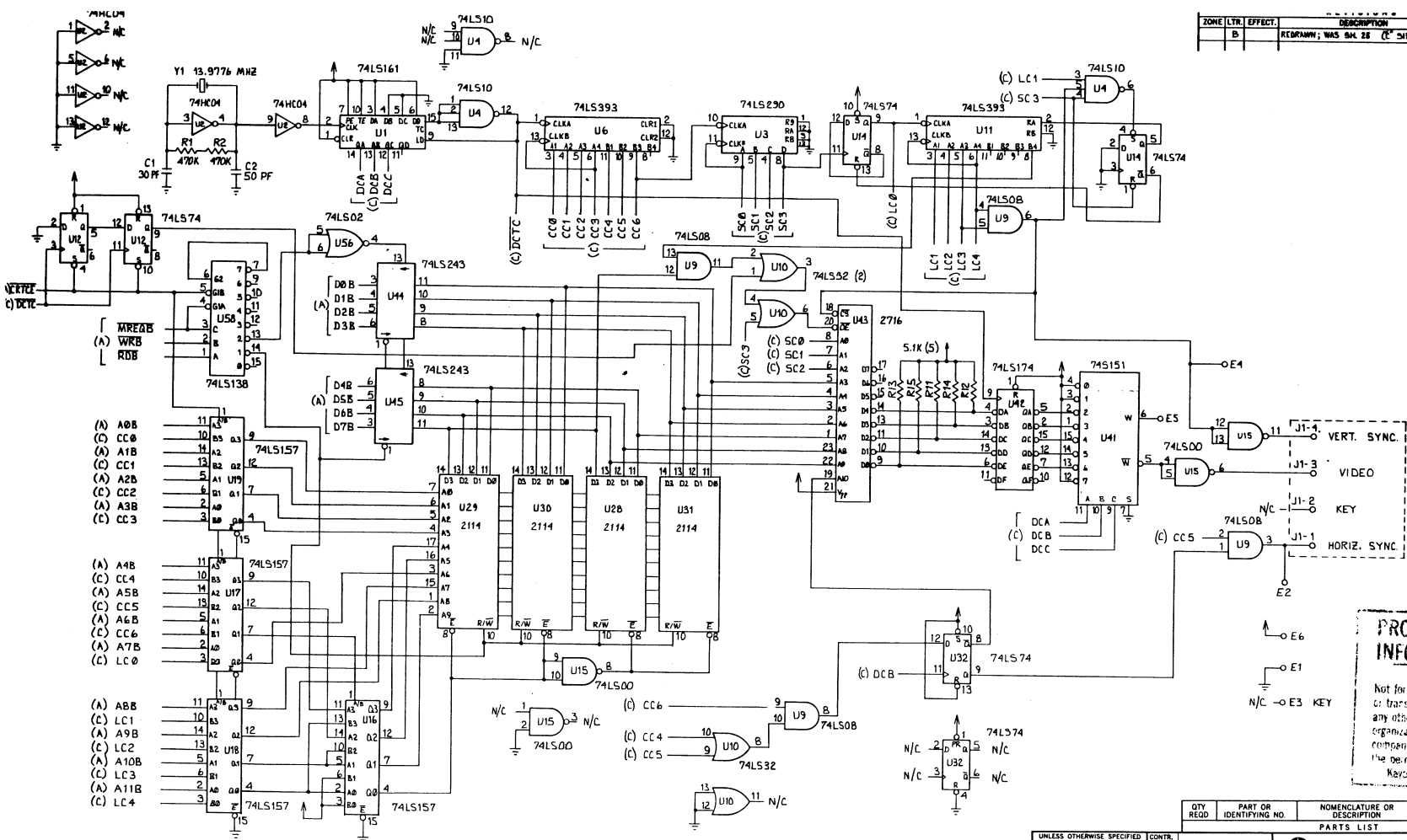

6-15

PROPRIETARY INFORMATION
 Not for distribution or transmission to any other person, organization or company without the permission of Raytheon Corporation.

QTY	PART OR IDENTIFYING NO.	NOMENCLATURE OR DESCRIPTION	MFR. CODE	CIRCUIT REF.	ITEI NO.
		PARTS LIST			
NON-LINEAR SYSTEMS, INC. DEL MAR, CALIFORNIA					
CRT CONTROL					
KAYPRO II/4					
SIZE	CODE IDENT NO.	81-241			
D	03626				
SCALE	TWEIGHT	LEAFLET 27			

UNLESS OTHERWISE SPECIFIED	CONTR. NO.
DIMENSIONS ARE IN INCHES	
TOLERANCES ON DECIMALS ±.010	DRAWN R 7 6-15-82
ANGLES ±.5°	CHECK
FRACTIONS ±1/32	APPR R 3 6-15-82
	RELEASE DATE
MATERIAL	
NEXT ASSY.	FINAL ASSY.
NEXT FINAL ASSY.	QTY

91--9

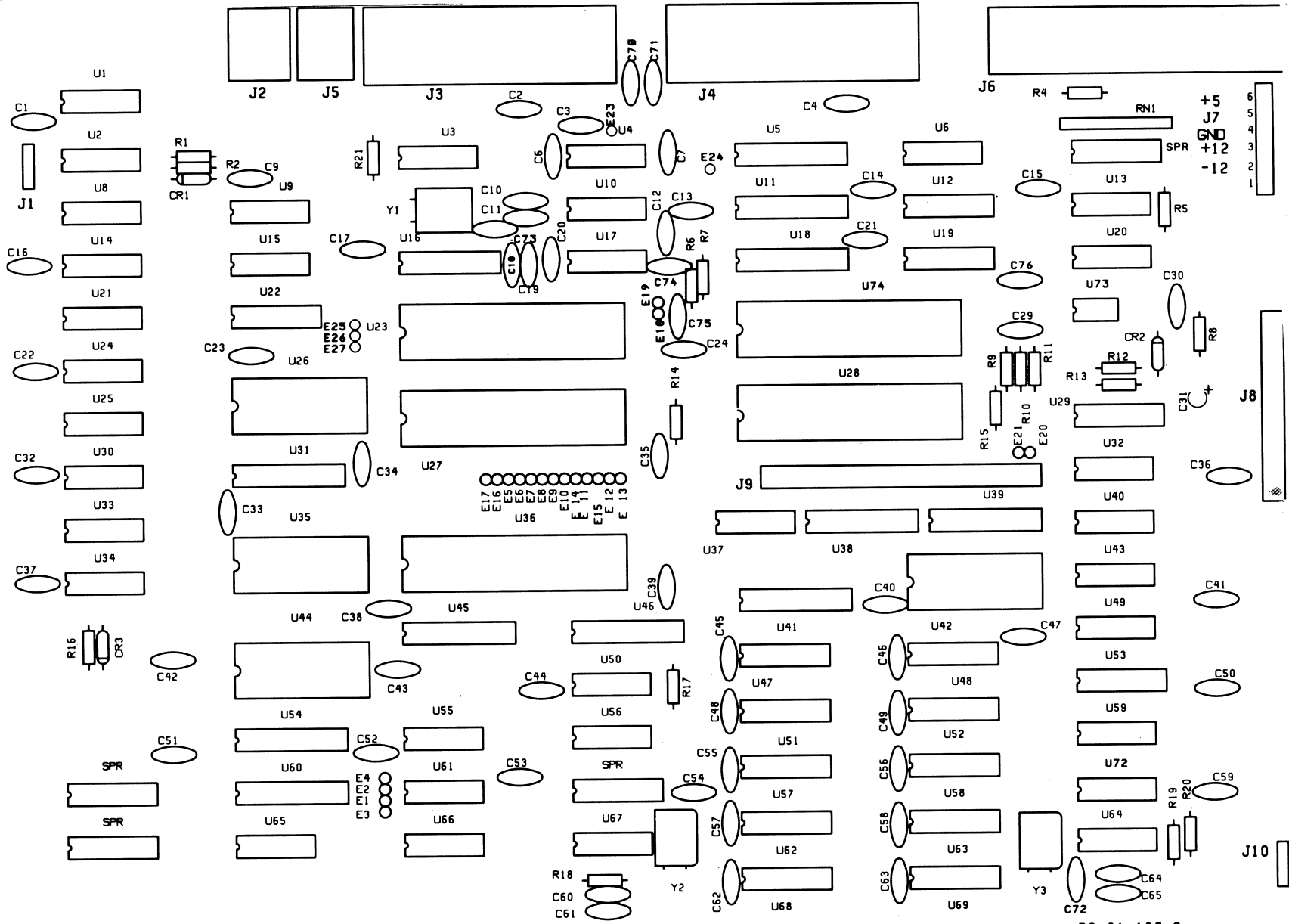

6.3 KAYPRO 18 MAINBOARD (81-180-n)

PC 81-180 C

IC LIST, 81-180-n

Reference Designation		Description
U1	74S74	Dual "D" flip-flop
U2	74S08	Hex Schmitt Quad AND gate
U3	74S04	Hex inverter
U4, U10	1489	Quad SCHMITT line receiver
U5, U38, U41	74LS244	Octal buffer
U6, U21, U24, U33, U49	74LS74	Dual "D" flip-flop
U20, U30	74LS08	Quad AND gate
U8, U37, U50	74LS00	Quad NAND gate
U9, U59	74LS393	Dual binary counter
U11, U18, U31, U45, U46, U60	74LS373	Octal "D" latch
U12, U19	74LS138	3/8 MUX
U13	7406	Hex inverter, open collector
U14	74S86	Hex Schmitt Quad XOR gate
U15, U61	74S20	Dual NAND gate
U16	8116	Dual programmable baud rate generator
U17	1488	Quad transmitter
U22	74LS165	8-bit shift register
U23, U27	Z80A SIO	
U25, U72	74LS10	Tri NAND gate
U26	81-187	Character generator EPROM (2732)
U28	Z80A CPU	
U29	74LS195	4-bit shift register
U32, U43	74LS02	Quad NOR gate
U34	74LS14	Hex Schmitt inverter
U35, U44	6116	RAM, 2K x 8-bit (200ns)
U36	6545A-1	Video controller
U39, U54	74LS245	Bi-directional 8-bit buffer
U42	81-302-C	Boot EPROM (2732)
U40	74LS32	Quad OR gate
U47, U48	74LS157	Quad 2/1 MUX
U51, U52, U57, U58, U62, U63, U68, U69	4565N-15	Dynamic RAM 64K x 1 (150ns) (Mostek number)
U53	74LS163	Synchronous 4-bit binary counter
U55	14-2-392	14-Pin pull-up resistor
U56, U65	74LS04	Hex inverter
U64, U67	74HCU04	Hex inverter, CMOS
U66	74LS93	Asynchronous 4-bit binary counter
U73	WD9216	Data separator
U74	1793	Floppy disk controller

SCOPE SIGNALS FOR TROUBLESHOOTING 81-180-n

The examples of correct signals shown here do not represent all of the signals on the 81-180-n mainboard, since most of the signals will be high-low toggles. A group of signals taken from a video clock divider (U66) are shown to illustrate the timing relationships between the various video signals.

The signal measurements were made using a Tektronix oscilloscope, model 2213. It has a bandwidth of DC-60 MHz, sensitivity of 2mV/cm, a sweep delay of 0.1 microseconds to 1 second, and a graticule display measuring 8 x 10 cm.

Each square of the representation is the equivalent of one square cm. on the graticule. The scope was set for 2V/div. and .2micro-secs/div. for all figures except figure 2, which was set at .5micro-secs/div.

Signal M1 from pin 27 of the CPU (U28) was triggered on. This signal is shown in the top half of each display and was channel 1. Ground for signals shown on channel 2 was established at the first graticule line above the bottom of the display.

State of the machine: The machine has just booted-up on the hard drive.

Figure 1: Pin 6 of U28, 4MHz clock signal.

Figure 2: Pin 24 of U74, 1MHz clock signal.

Figure 3: Pin 12 of U66, video, clock divider.

Figure 4: Pin 9 of U66, video, clock divider.

Figure 5: Pin 8 of U66, video, clock divider.

Figure 6: Pin 11 of U66, video, clock divider.

FIGURE 1

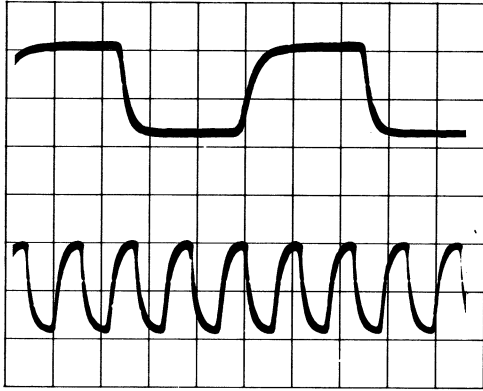

FIGURE 2

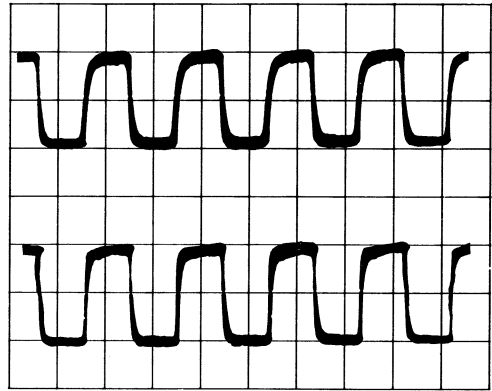

FIGURE 3

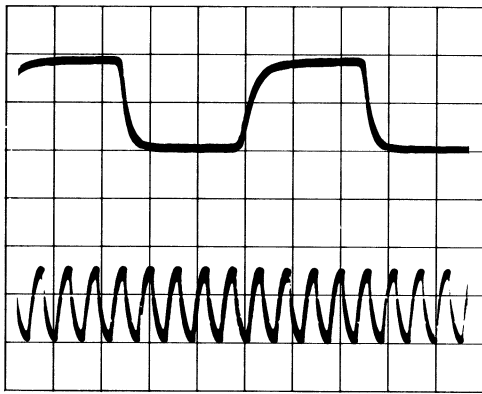

FIGURE 4

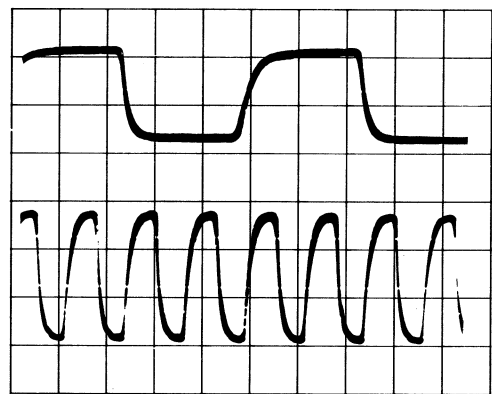

FIGURE 5

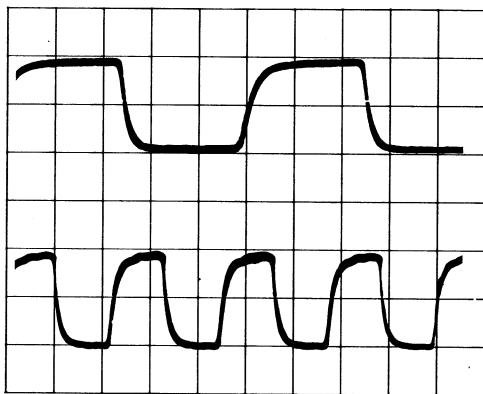
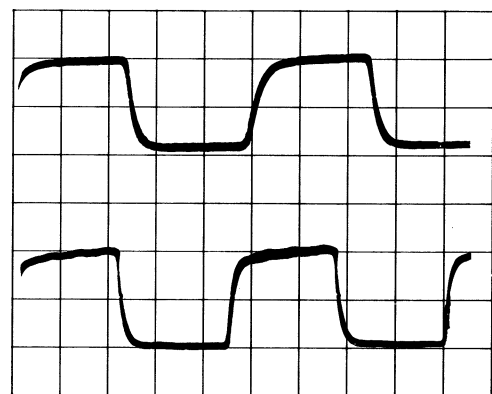
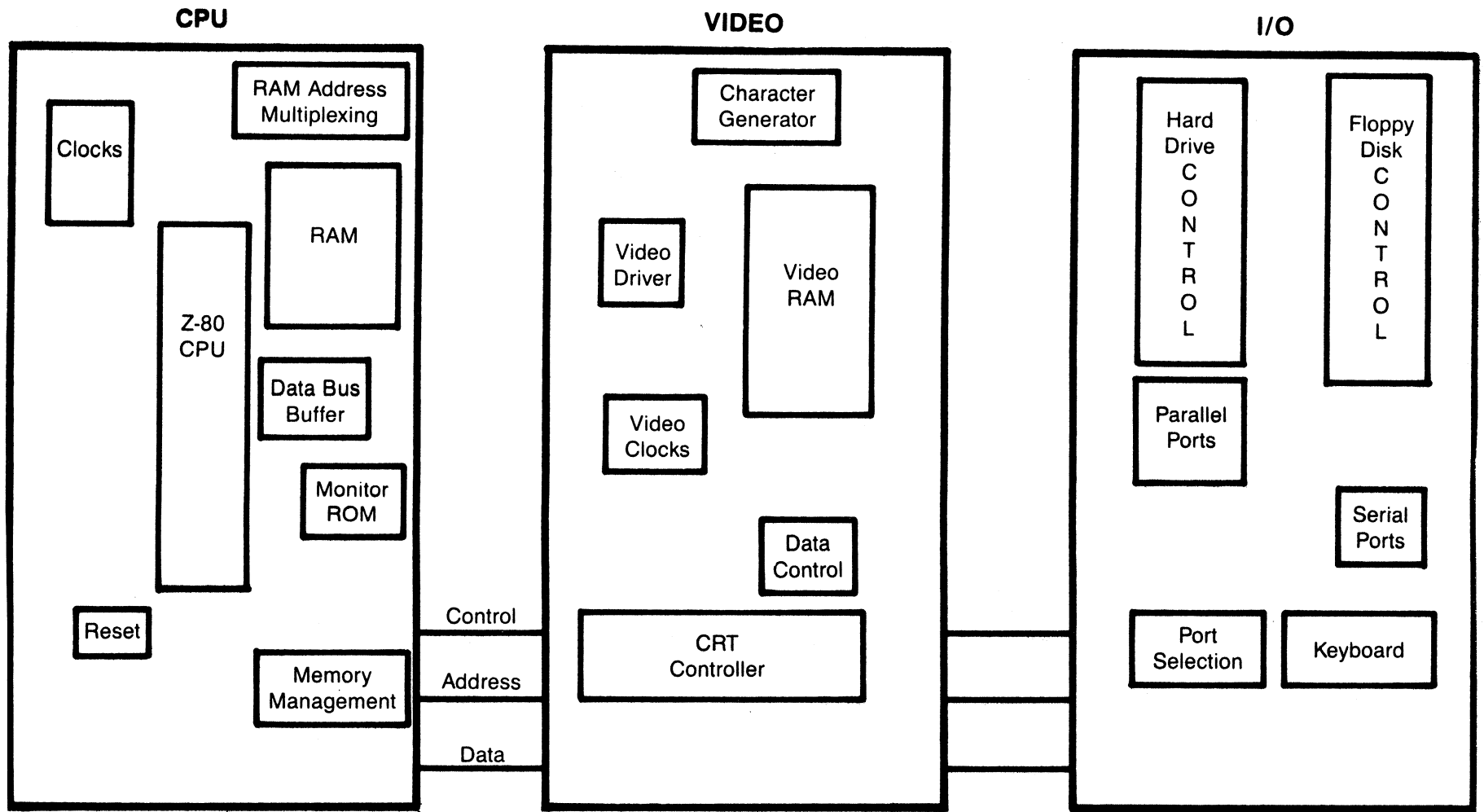
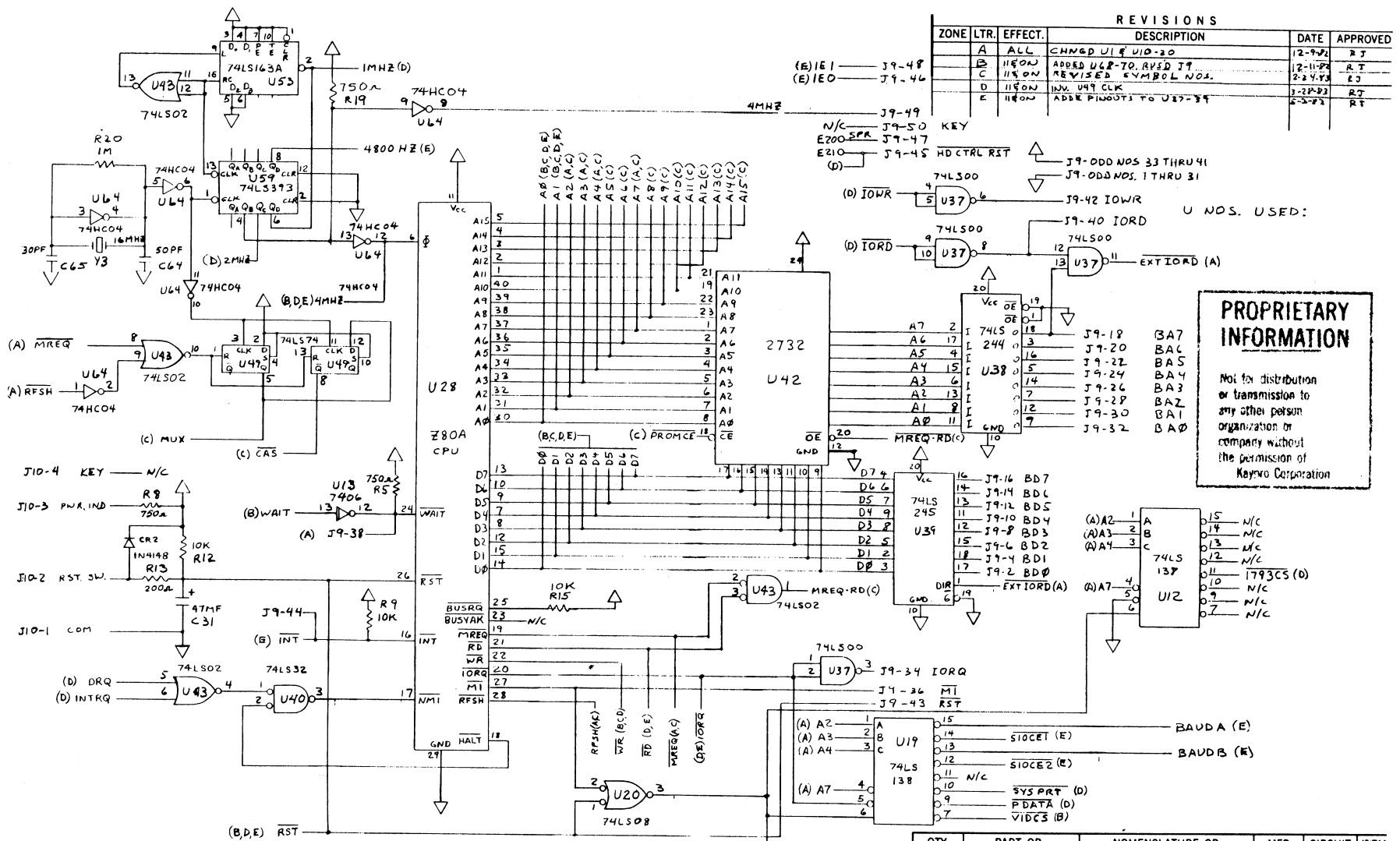

FIGURE 6





KAYPRO 10 BLOCK DIAGRAM



ZONE	LTR.	EFFECT.	DESCRIPTION	DATE	APPROVED
	A	ALL	CHANGED U1 & U10-20	12-9-82	R J
	B	11/80N	ADDED U42-70, REVISED J7	12-11-82	R J
	C	11/80N	REVISED SYMBOL NOS.	2-24-83	R J
	D	11/80N	INV. U47 CLK	3-22-83	R J
	E	11/80N	ADDED PINS TO U12-34	5-23-83	R J

KEY
 J9-49 N/C
 J9-50 J9-50
 J9-47 E200-SPR
 J9-45 (D) J9-45
 HD CTRL RST
 J9-ODD NOS 33 THRU 41
 J9-ODD NOS. 1 THRU 31
 J9-42 IOWR
 J9-40 IORD
 U NOS. USED:
 J9-18 (A)7
 J9-20 (A)8
 J9-22 (A)9
 J9-24 (A)10
 J9-26 (A)11
 J9-28 (A)12
 J9-30 (A)13
 J9-32 (A)14

PROPRIETARY INFORMATION
 Not for distribution or transmission to any other person, organization or company without the permission of Kaypro Corporation

- SPARE J7-1 _____
 -12V J7-2 _____ TO: U61-1, J2-5
 +12V J7-3 _____ TO: U61-14, J2-2, U55-40
 GND J7-4 _____
 KEY J7-5 _____ N/C
 +5V J7-6 _____

QTY REQD	PART OR IDENTIFYING NO.	NOMENCLATURE OR DESCRIPTION	MFR. CODE	CIRCUIT REF.	ITEM NO.
----------	-------------------------	-----------------------------	-----------	--------------	----------

UNLESS OTHERWISE SPECIFIED
 DIMENSIONS ARE IN INCHES
 TOLERANCES ON
 DECIMALS ± .010
 FRACTIONS ± 1/32
 ANGLES ± 0° 30'

NLS NON-LINEAR SYSTEMS, INC.
 DEL MAR, CALIFORNIA

SCHEMATIC, PROCESSOR

KAYPRO 10

APPLICATION	QTY.

SIZE	CODE IDENT NO.	SCALE	WEIGHT	SHEET 2A
C	03626			81-181

6-22

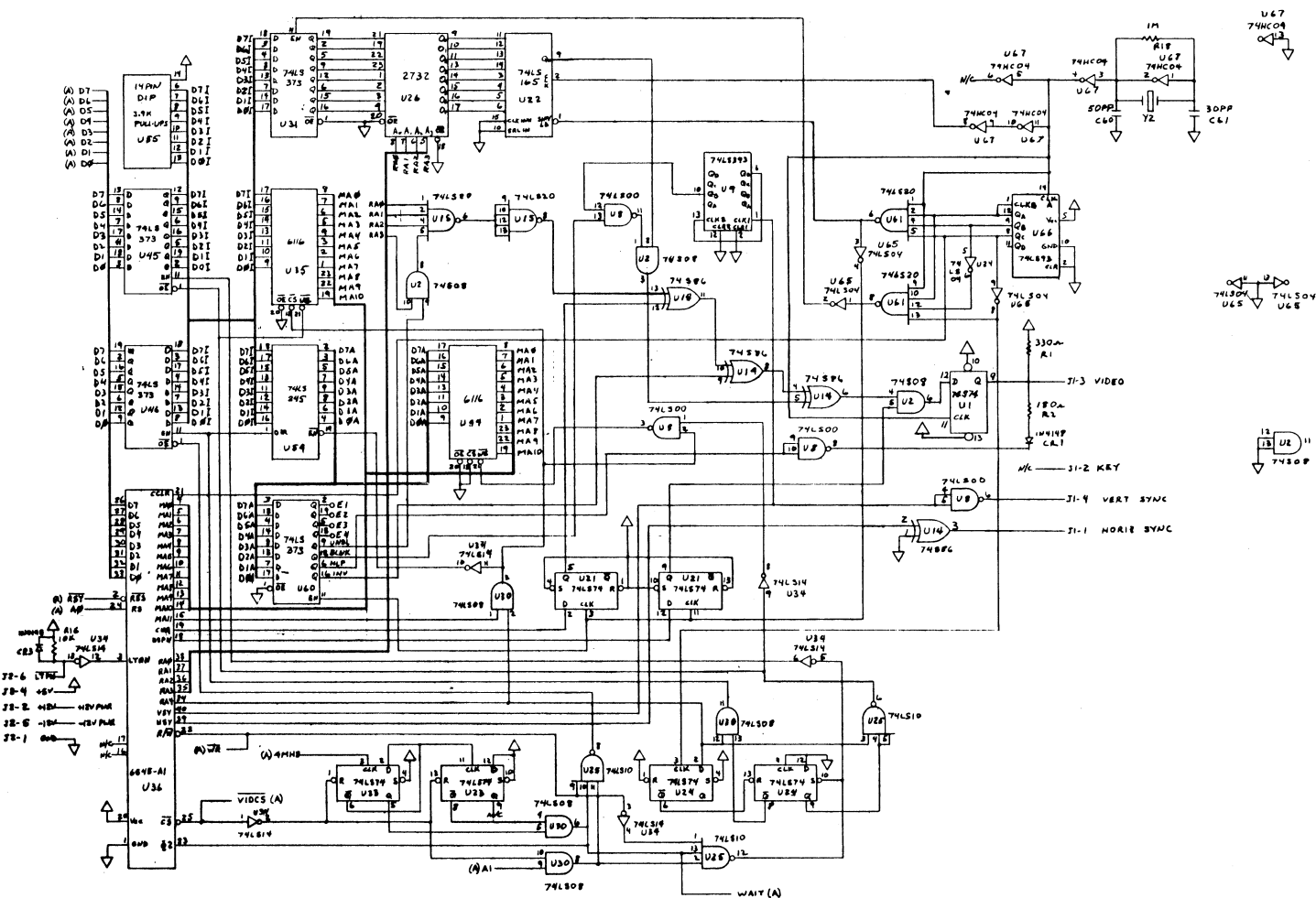

REVISIONS					
ZONE	LTR.	EFFECT	DESCRIPTION	DATE	APPROVED
A	ALL		CHG COMMENTS TO U36, U37, U38	12-28-73	A.T.
B	11-11-73		ADD U11	12-28-73	A.T.
C	11-11-73		REVISE SYMBOL U01	12-28-73	A.T.

U NOS. USED:

PROPRIETARY INFORMATION

Not for distribution or transmission to any other person, organization or company without the permission of Kaypro Corporation

P.C. BD: 61-180

QTY REQD	PART OR IDENTIFYING NO.	NOMENCLATURE OR DESCRIPTION	MFR CODE	CIRCUIT REF.	ITEM NO.
PARTS LIST					

UNLESS OTHERWISE SPECIFIED:
 DIMENSIONS ARE IN INCHES
 TOLERANCES ON DECIMALS ± .005
 FRACTIONS ± 1/32

CONTR. NO. _____
 DRAWN RWT 12-28-73
 CHECK _____
 APPR RY 12-28-73
 RELEASE DATE _____

NON-LINEAR SYSTEMS, INC.
 DEL. MAR. CALIFORNIA

SCHEMATIC, VIDEO

KAYPRO 10

SIZE CODE IDENT. NO. _____
D 03626 81-181
 SCALE _____ WEIGHT _____ SHEET 2 B

APPLICATION	FINAL ASSY.	NEXT FINAL ASSY.	QTY.

6-23

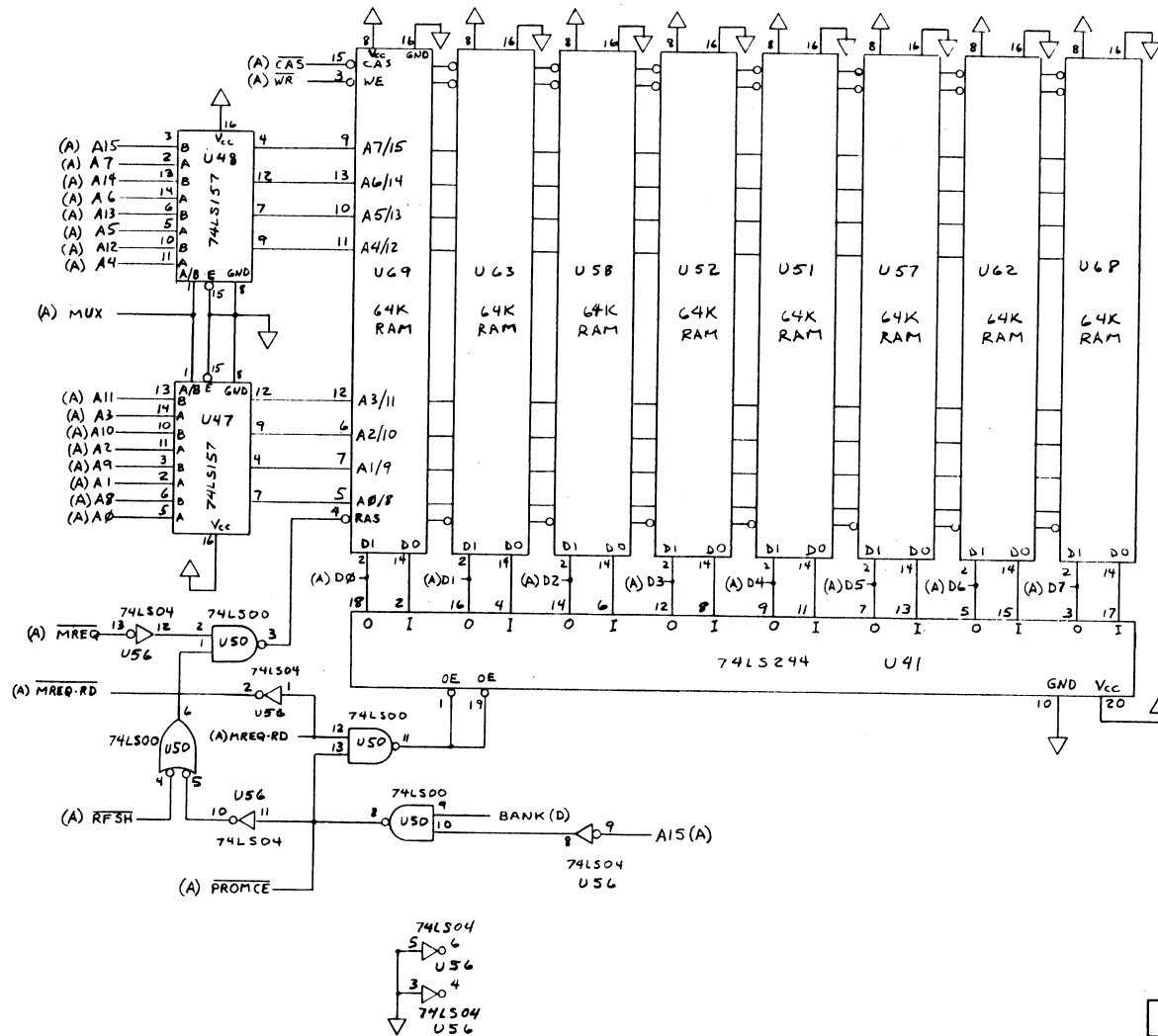

REVISIONS					
ZONE	LTR.	EFFECT.	DESCRIPTION	DATE	APPROVED
A	ALL		ADD COMM TO U49	12-7-82	RJ
B	1190N		REVISED SYMBOL NOS	2-24-83	RJ

UNOS USED:

PROPRIETARY INFORMATION
 Not for distribution or transmission to any other person, organization or company without the permission of Raytheon Corporation.

QTY REQD	PART OR IDENTIFYING NO.	NOMENCLATURE OR DESCRIPTION	MFR. CODE	CIRCUIT REF.	ITEM NO.
----------	-------------------------	-----------------------------	-----------	--------------	----------

PARTS LIST

UNLESS OTHERWISE SPECIFIED		CONTR. NO.
DIMENSIONS ARE IN INCHES		DRAWN R J 10-4-72
TOLERANCES ON		CHECK
DECIMALS ±.010	ANGLES ± 0° 30'	APPR R J 12-9-82
FRACTIONS ± 1/32		RELEASE DATE

NLS NON-LINEAR SYSTEMS, INC.
 DEL MAR, CALIFORNIA

SCHEMATIC, RAM
 KAYPRO 10

SIZE C CODE IDENT NO. 03626 81-181

APPLICATION	QTY.
NEXT ASSY.	FINAL ASSY.
NEXT ASSY.	FINAL ASSY.

SCALE WEIGHT SHEET 2 C

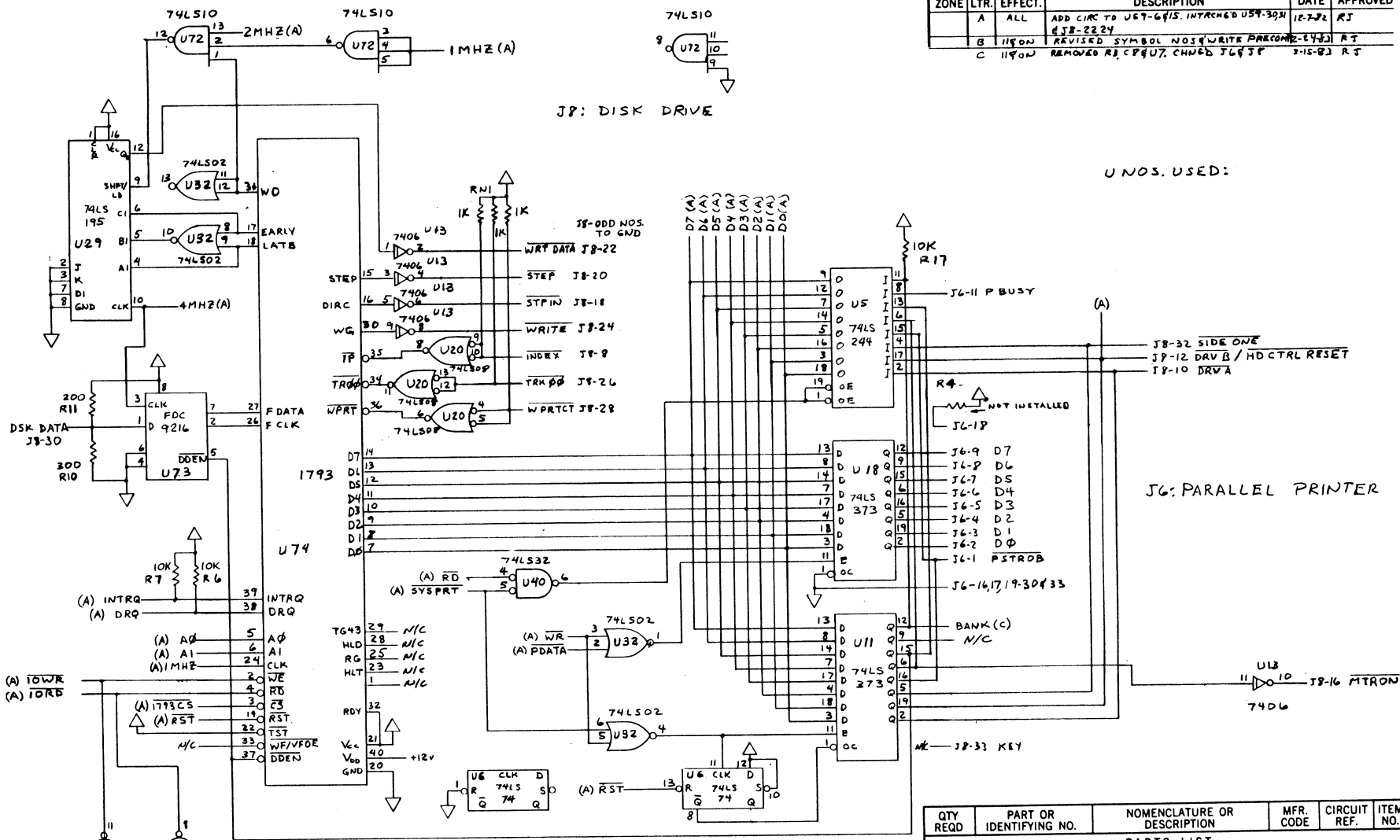

REVISIONS					
ZONE	LTR.	EFFECT.	DESCRIPTION	DATE	APPROVED
	A	ALL	ADD CIRC TO U67-G415, INTRCH4'D U54-30N	12-7-82	RJ
	B	118 ON	REVISED SYMBOL NOS & WRITE PARCOMP-243		RT
	C	119 ON	REMOVED R3, C9 & U7, CHANGED J6 & J7	3-15-83	RT

UNOS. USED:

QTY REQD	PART OR IDENTIFYING NO.	NOMENCLATURE OR DESCRIPTION	MFR. CODE	CIRCUIT REF.	ITEM NO.
----------	-------------------------	-----------------------------	-----------	--------------	----------

NON-LINEAR SYSTEMS, INC.
DEL MAR, CALIFORNIA

SCHEMATIC FLOPPY CONTROL
& PARALLEL PRINTER
KAYPRO 10

SIZE	CODE IDENT NO.	
C	03626	81-181
SCALE	WEIGHT	SHEET 2 D

PROPRIETARY INFORMATION
Not for distribution or use in excess of the minimum necessary for repair, parts or maintenance of equipment without the permission of Kaypro Corporation.

UNLESS OTHERWISE SPECIFIED		CONTR. NO.
DIMENSIONS ARE IN INCHES		DRAWN RJ 10-4-82
DECIMALS ±.010	ANGLES ± 0° 30'	CHECK
FRACTIONS ± 1/32		APPR RJ 12-9-82
MATERIAL		RELEASE DATE

NEXT ASSY.	FINAL ASSY.	NEXT FINAL ASSY.	FINAL ASSY.
APPLICATION	QTY.		

REVISIONS					
ZONE	LTR.	EFFECT.	DESCRIPTION	DATE	APPROVED
	A	ALL	INTRCHG DB D4#D2,D3 INTO U64	12-7-72	R J
	B	1190N	INTRENED A&B SECTIONS OF U63	12-27-72	R J
	C	1190N	REVISED SYMBO NOS.	2-27-73	R J
	D	12180N	ADDED CONNECTIONS TO J3-15(17)	3-27-73	R J
	D1	12180N	REVERSED J315 & 17	6-27-73	R J

U NOS. USED:

MODEM

KEYBOARD

PROPRIETARY INFORMATION

Not for distribution or transmission to any other person, organization or company without the permission of Kaypro Corporation

QTY REQD	PART OR IDENTIFYING NO.	NOMENCLATURE OR DESCRIPTION	MFR. CODE	CIRCUIT REF.	ITEM NO.
PARTS LIST					

UNLESS OTHERWISE SPECIFIED		CONTR. NO.	
DIMENSIONS ARE IN INCHES		DRAWN	R J 10-4-72
TOLERANCES ON ANGLES		CHECK	
DECIMALS ± .010	FRACTIONS ± 1/32	APPR	R J 11-9-72
		RELEASE DATE	

NLS NON-LINEAR SYSTEMS, INC.
DEL MAR, CALIFORNIA

SCHMATIC, SERIAL PORTS

KAYPRO 10

SIZE **C** CODE IDENT NO. **03626** 81-181

SCALE WEIGHT SHEET **2 E**

APPLICATION	QTY.
NEXT ASSY.	FINAL ASSY.
NEXT FINAL ASSY.	FINAL ASSY.

6-25

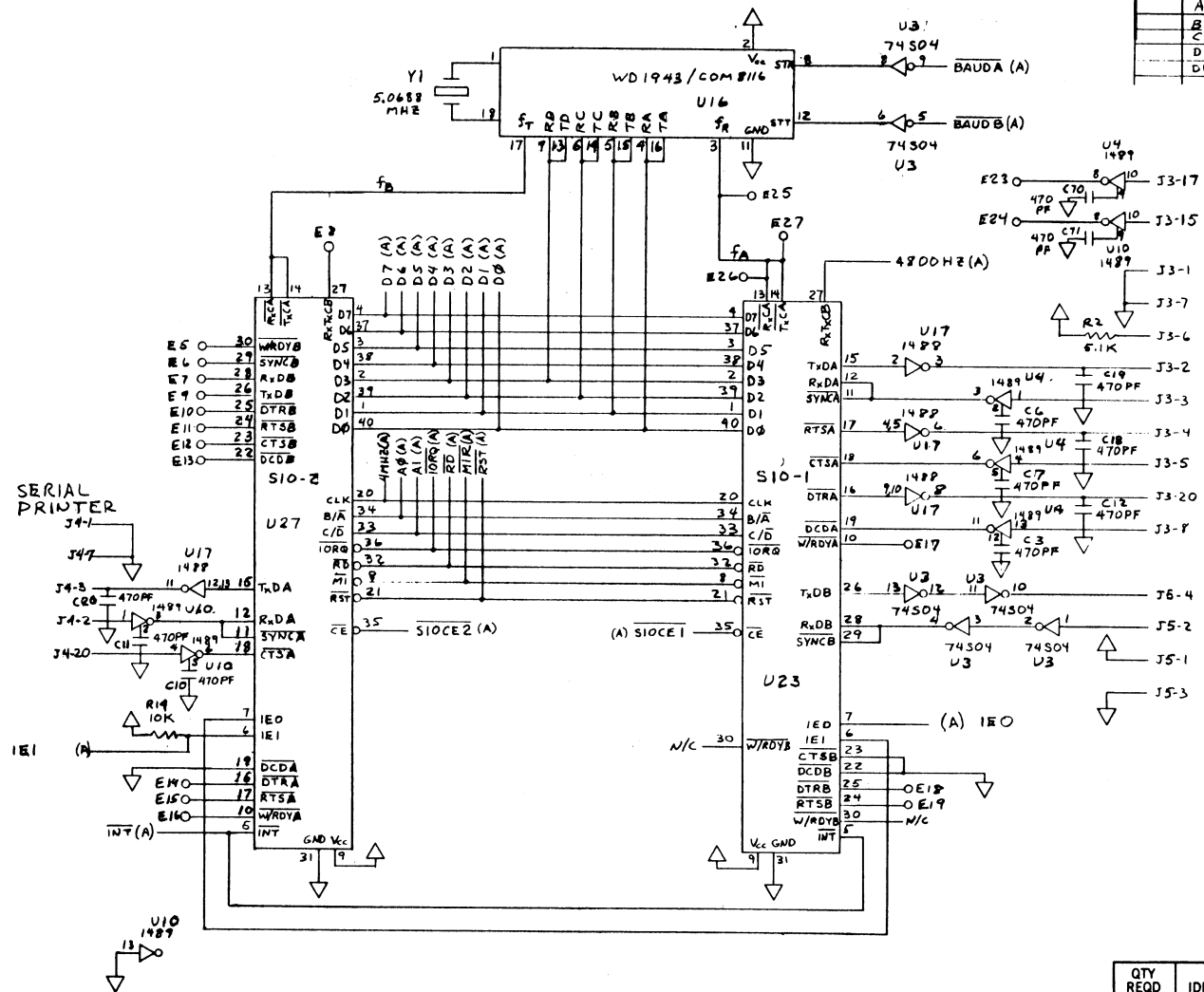

6.4 KAYPRO 2/84 AND 2X (81-294-1)

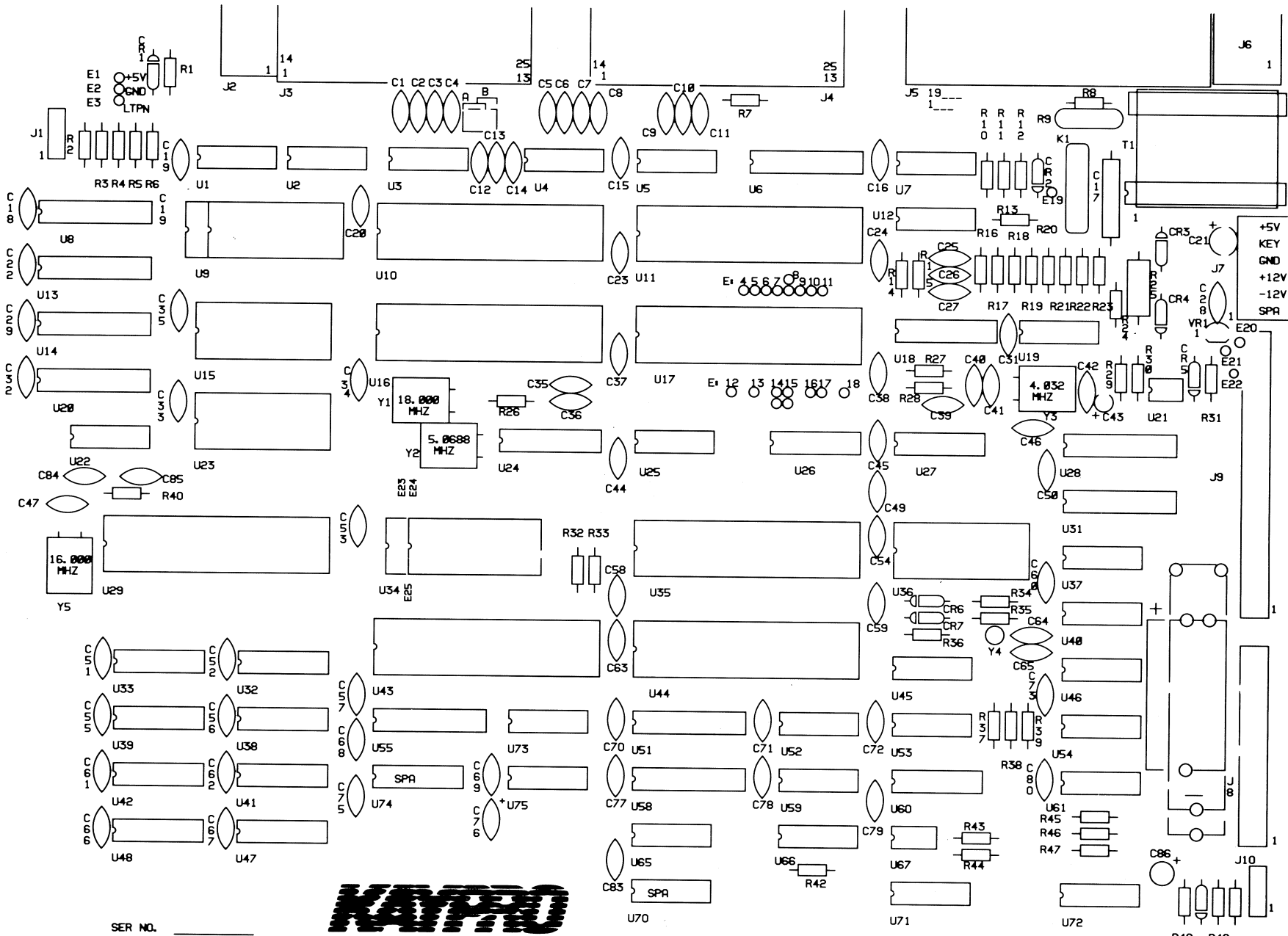

SER. NO. _____

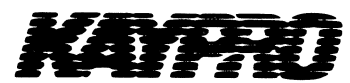

MADE IN U. S. A.

ASSY 81- _____

R48 R49
CR8 R50

IC LIST, 81-294-n

Reference Designation		Description
U1, U54	7406	Hex inverter, open collector
U2, U25, U71	74LS14	Hex Schmitt inverter
U3, U5	1489	Quad Schmitt line driver
U4	1488	Quad line driver
U6, U13, U14, U55, U58	74LS373	Octal "D" latch
U8	74LS374	Octal "D" flip-flop
U9	81-235-n	Character PROM (2732)
U10	81-189	Custom gate array
U11, U17	Z80 SIO	
U15, U23	6116	Video RAM
U16	6545EA	CRT controller
U20, U31	74LS245	Octal bus transceiver
U22	3.9K	Pull-up Resistor
U24	WD1943/ 8116	Dual programmable baud rate generator
U26, U27	74LS138	3/8 MUX
U28, U51	74LS244	Octal buffer/line driver (3-state outputs)
U29	81-194	Custom gate array
U32, U33, U38, U39, U41, U42, U47, U48	2164	64K x 1 RAM
U34	81-292	Boot PROM (2764)
U37, U45, U59, U72	74LS02	Quad NOR gate
U40	74LS00	Quad NAND gate
U43	Z80A CPU	
U44	1793	Floppy disk controller
U46	74LS04	Hex inverter
U52	74LS32	Quad OR gate
U60	74LS195	4-bit shift register
U61	74LS08	Quad AND gate
U65	74LS10	Tri NAND gate
U66, U75	74LS74	Dual "D" flip-flop
U67	FDC9216	Data separator
U73	74HC00	Quad NAND gate

REVISIONS

ZONE	LTR.	EFFECT.	DESCRIPTION	DATE	APPROVED
E210	SPR	J9-48			

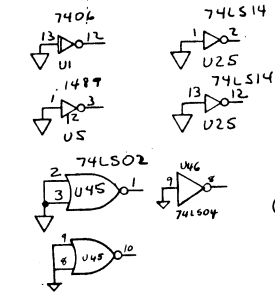

SPARE I.C.S:
U53, U70,
U74, U75

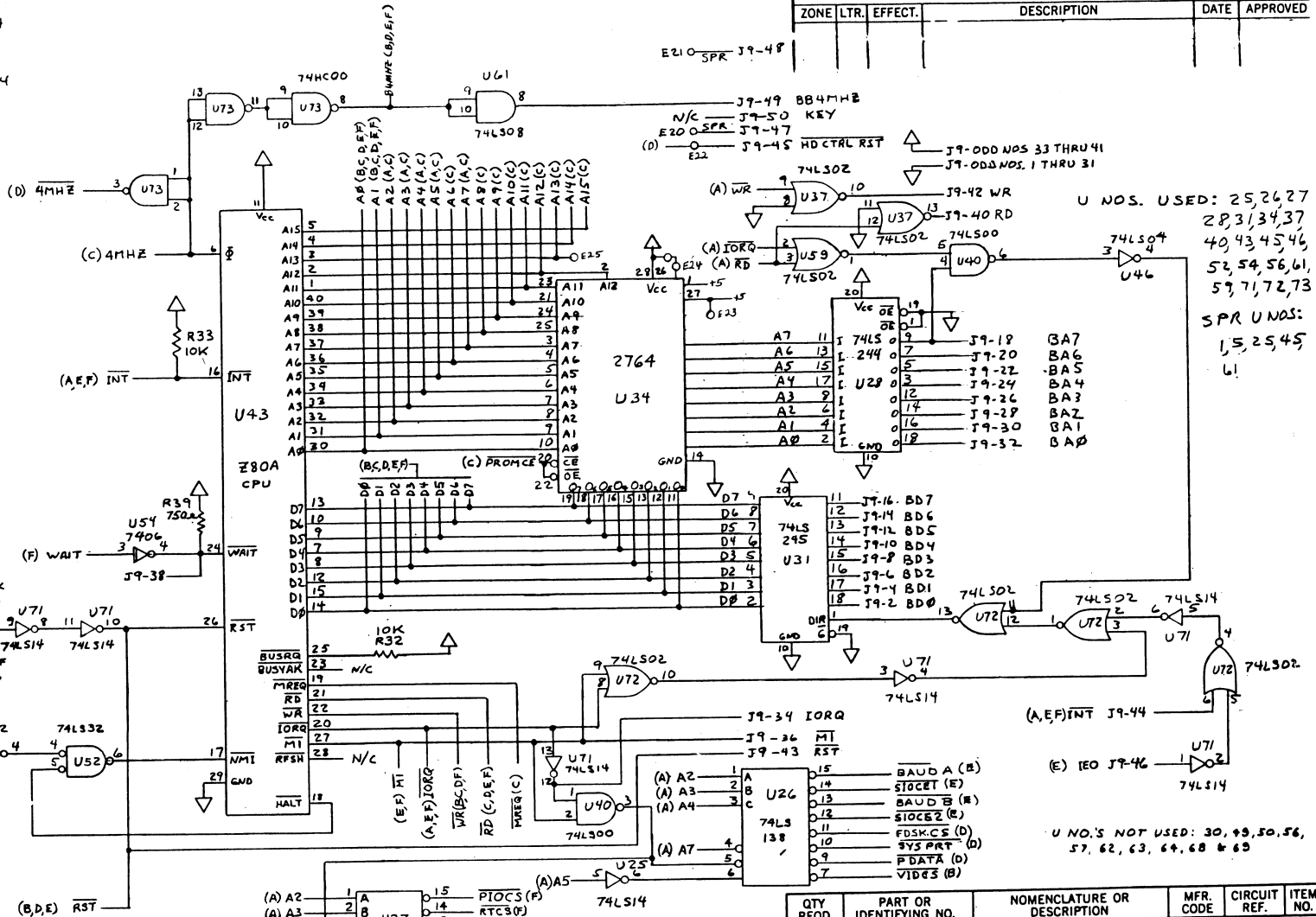
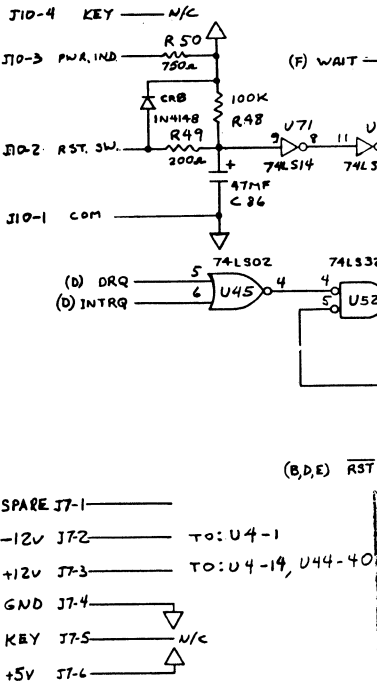

J9-49 884MHz
N/C J9-50 KEY
E200 SPR J9-47
(D) J9-45 HD CTRL RST
J9-000 NOS 33 THRU 41
J9-000 NOS. 1 THRU 31

U NOS. USED: 25, 26, 27
28, 31, 34, 37
40, 43, 45, 46
53, 54, 56, 61,
59, 71, 72, 73
SPR UNOS:
1, 5, 25, 45
61

BA7
BA6
BA5
BA4
BA3
BA2
BA1
BA0

U NOS NOT USED: 30, 49, 50, 56,
57, 62, 63, 64, 68 & 69

PROPRIETARY INFORMATION
Not for distribution or transmission to any other person, organization or company without the permission of Kaypro Corporation

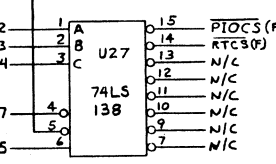

UNLESS OTHERWISE SPECIFIED	CONTR. NO.
DIMENSIONS ARE IN INCHES	
TOLERANCES ON	
DECIMALS ± .010	
FRACTIONS ± 1/32	
ANGLES ± 0° 30'	

QTY REQD	PART OR IDENTIFYING NO.	NOMENCLATURE OR DESCRIPTION	MFR. CODE	CIRCUIT REF.	ITEM NO.
----------	-------------------------	-----------------------------	-----------	--------------	----------

NON-LINEAR SYSTEMS, INC.
DEL MAR, CALIFORNIA

SCHEMATIC, PROCESSOR

KAYPRO 2/84

SIZE C CODE IDENT NO. 03626 81-295

SCALE WEIGHT SHEET 2A

APPLICATION	QTY.
NEXT ASSY.	
FINAL ASSY.	
NEXT FINAL ASSY.	
FINAL ASSY.	

BOARD REV A

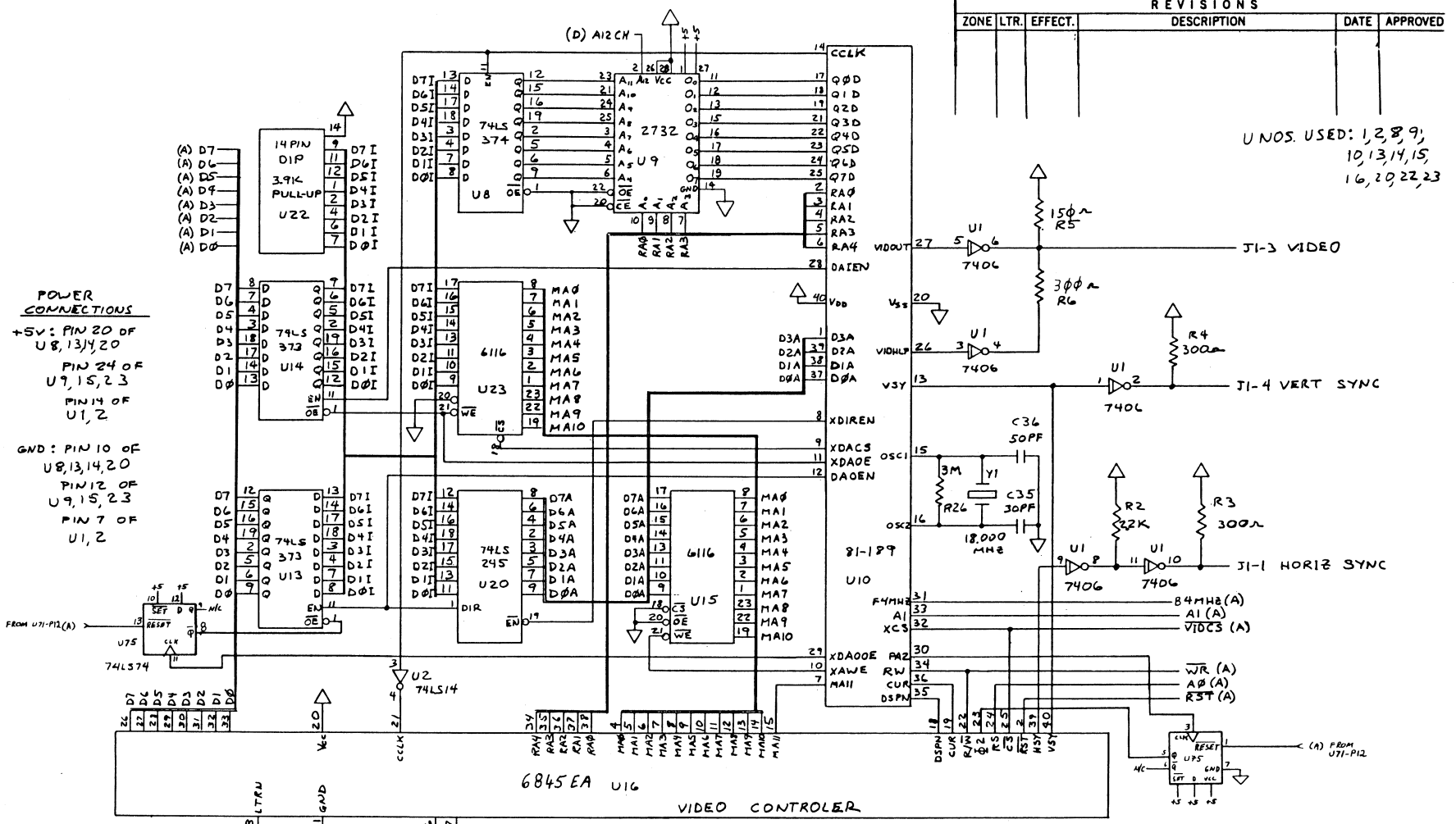

POWER CONNECTIONS
 +5V: PIN 20 OF U8, 13, 14, 20
 PIN 24 OF U9, 15, 23
 PIN 14 OF U1, 2
 GND: PIN 10 OF U8, 13, 14, 20
 PIN 12 OF U9, 15, 23
 PIN 7 OF U1, 2

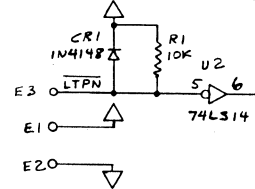

PROPRIETARY INFORMATION
 Not for distribution
 or transmission to
 any other person
 organization or
 company without
 the permission of
 NLS Corporation.

APPLICATION	FINAL ASSY.	NEXT FINAL ASSY.	QTY.

REVISIONS					
ZONE	LTR.	EFFECT.	DESCRIPTION	DATE	APPROVED

UNOS. USED: 1, 2, 8, 9,
 10, 13, 14, 15,
 16, 20, 22, 23

QTY REQD	PART OR IDENTIFYING NO.	NOMENCLATURE OR DESCRIPTION	MFR. CODE	CIRCUIT REF.	ITEM NO.
PARTS LIST					
UNLESS OTHERWISE SPECIFIED					
DIMENSIONS ARE IN INCHES		CONTR. NO.			
TOLERANCES ON		DRAWN RJ 2-29-84			
DECIMALS ± .010		CHECK			
ANGLES ± 0° 30'		APPR RWJ 2-27-84			
FRACTIONS ± 1/32		RELEASE DATE 3-6-84 KSI			
MATERIAL		BOARD REV A			
NON-LINEAR SYSTEMS, INC. DEL MAR, CALIFORNIA					
SCHEMATIC, VIDEO					
KAYPRO 2/84					
SIZE	CODE IDENT NO.	81-295		SHEET 2 B	
C	03626	SCALE	WEIGHT		

REVISIONS					
ZONE	LTR.	EFFECT.	DESCRIPTION	DATE	APPROVED

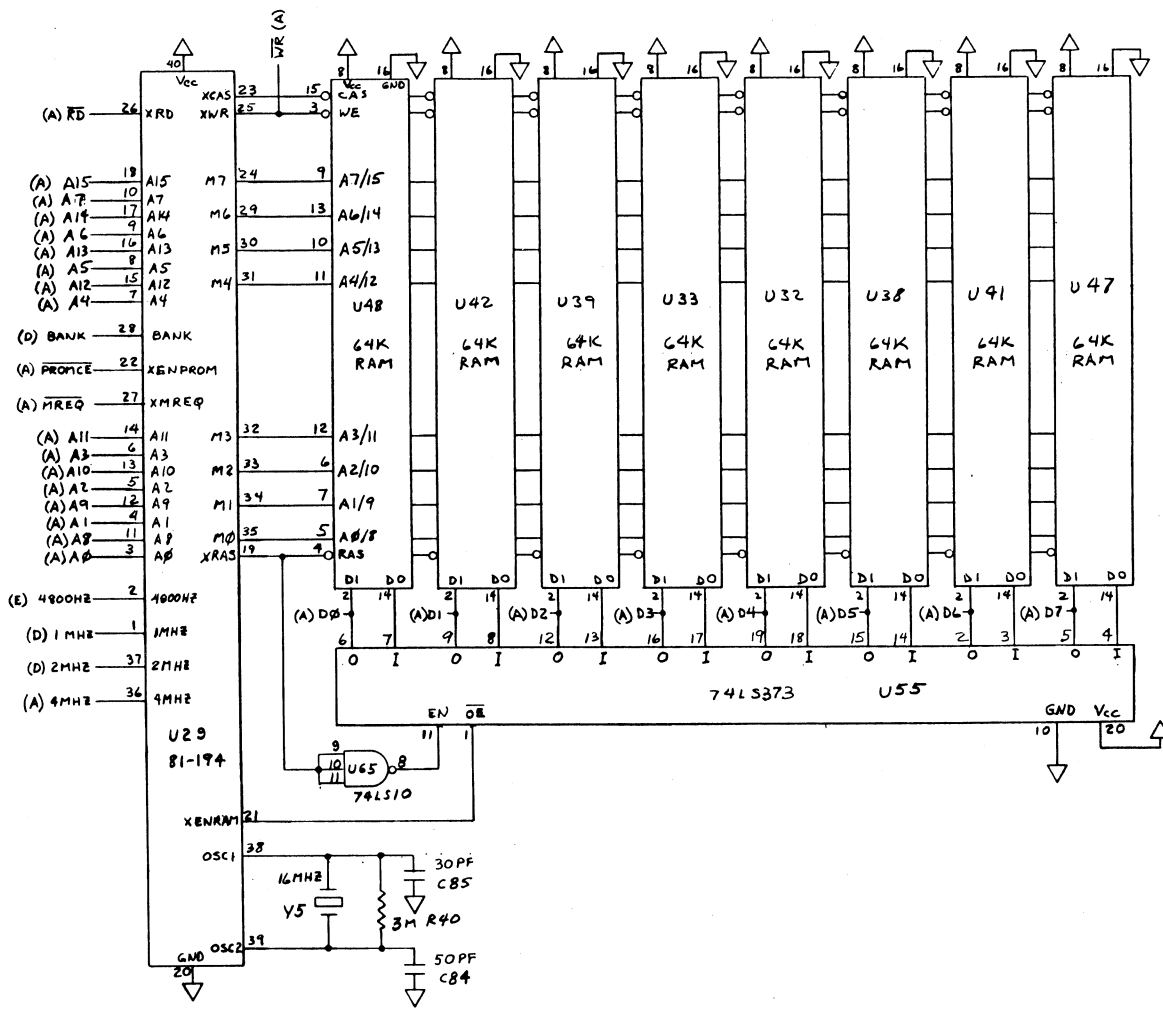

UNOS USED: 29, 48, 42,
39, 33, 32, 38, 41, 47, 55,
65

PROPRIETARY INFORMATION
Not for distribution or transmission to any other person or organization or company without the permission of Kaypro Corporation

QTY REQD	PART OR IDENTIFYING NO.	NOMENCLATURE OR DESCRIPTION	MFR. CODE	CIRCUIT REF.	ITEM NO.
PARTS LIST					

UNLESS OTHERWISE SPECIFIED		CONTR. NO.
DIMENSIONS ARE IN INCHES		DRAWN <i>ZJ</i> <i>2-24-84</i>
TOLERANCES ON		CHECK
DECIMALS ± .010	ANGLES ± 0° 30'	APPR <i>ZJ</i> <i>2-29-84</i>
FRACTIONS ± 1/32		RELEASE DATE <i>3-6-84 KSI</i>

NLS		NON-LINEAR SYSTEMS, INC. DEL MAR, CALIFORNIA	
SCHEMATIC, RAM			
KAYPRO 2/84			
SIZE	CODE IDENT NO.	81-295	
C	03626		
SCALE	WEIGHT	SHEET 2 C	

APPLICATION	NEXT ASSY.	FINAL ASSY.	NEXT FINAL ASSY.	QTY.

6-30

6-31

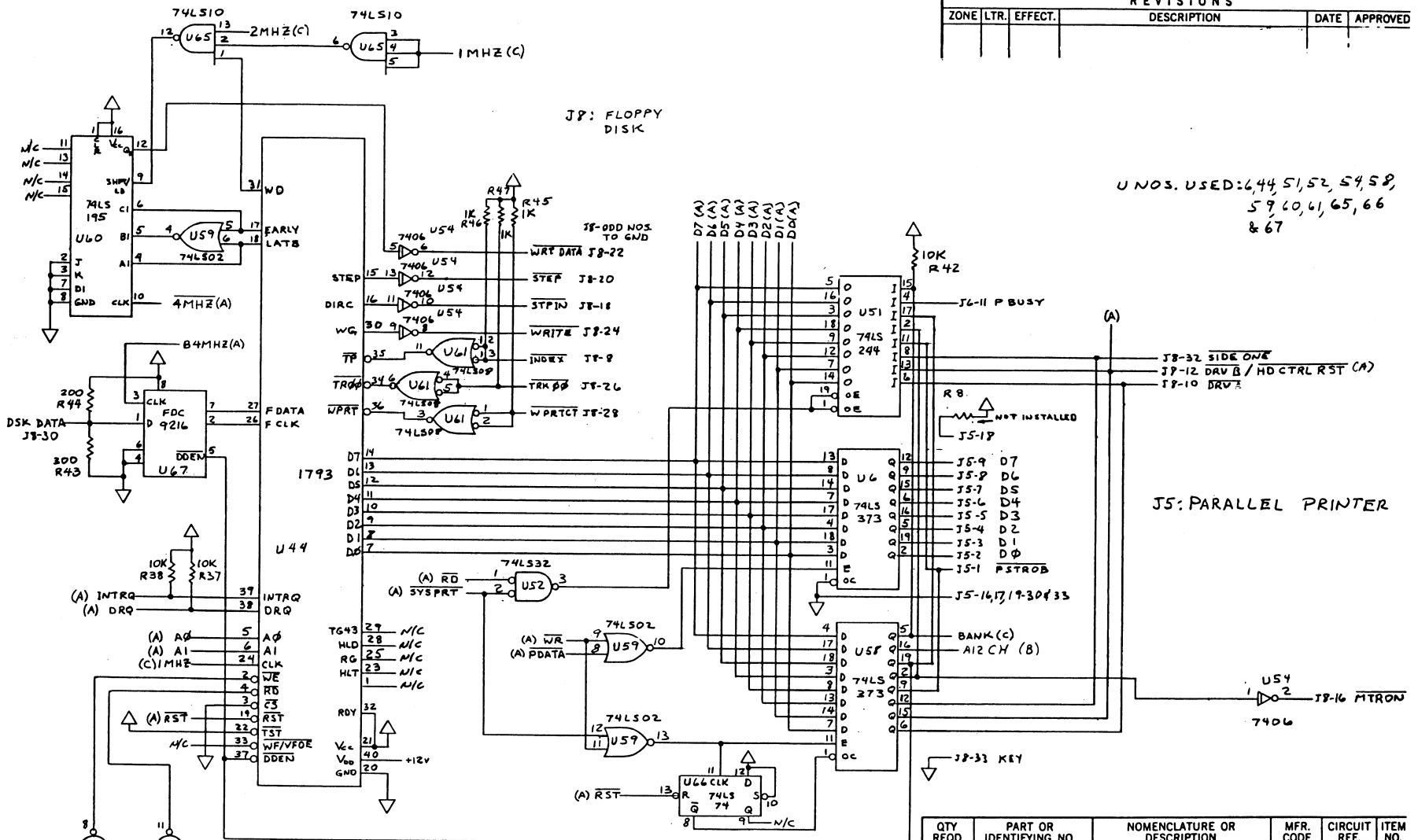

REVISIONS					
ZONE	LTR.	EFFECT.	DESCRIPTION	DATE	APPROVED

U NOS. USED: 644, 51, 52, 54, 58,
59, 60, 61, 65, 66
& 67

PROPRIETARY INFORMATION
Not for distribution or reproduction to any other person, organization or company without the permission of Logic Corporation.

APPLICATION	QTY.
NEXT ASSY.	
FINAL ASSY.	
NEXT FINAL ASSY.	
FINAL ASSY.	

UNLESS OTHERWISE SPECIFIED
DIMENSIONS ARE IN INCHES
TOLERANCES ON
DECIMALS ± .010
FRACTIONS ± 1/32
ANGLES ± 0° 30'

CONTR. NO.	
DRAWN	RJ 2-29-84
CHECK	
APPR	RJ 2-29-84
RELEASE DATE	3-6-84 KSI
Board Rev A	

QTY REQD	PART OR IDENTIFYING NO.	NOMENCLATURE OR DESCRIPTION	MFR. CODE	CIRCUIT REF.	ITEM NO.
----------	-------------------------	-----------------------------	-----------	--------------	----------

NLS NON-LINEAR SYSTEMS, INC.
DEL MAR, CALIFORNIA

SCHEMATIC, FLOPPY CONTROL & PARALLEL PRINTER

KAYPRO 2/84

SIZE	CODE IDENT NO.	
C	03626	81-295
SCALE	WEIGHT	SHEET D

REVISIONS					
ZONE	LTR.	EFFECT.	DESCRIPTION	DATE	APPROVED

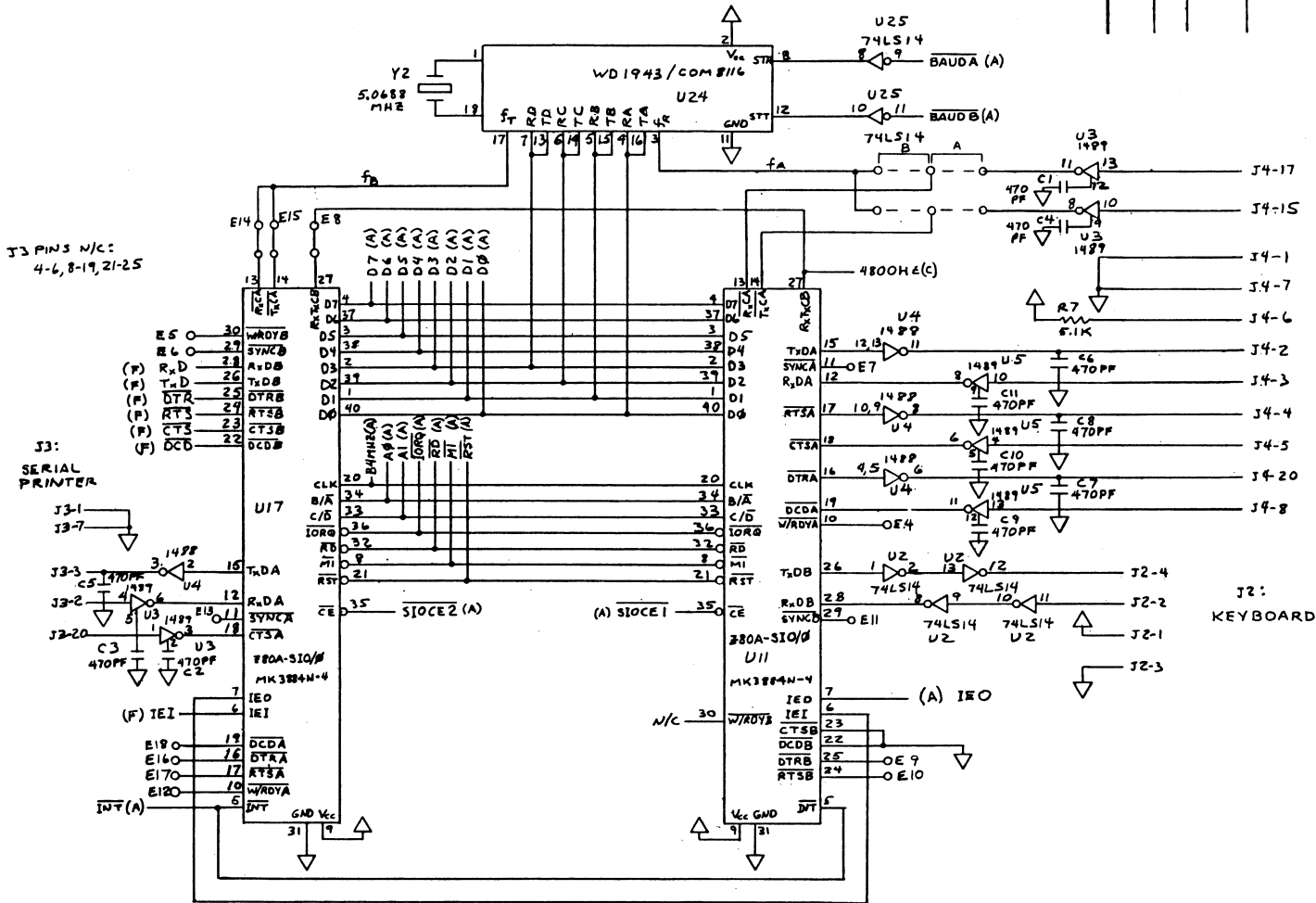

U NOS. USED: 2, 3, 4, 5, 11
17, 24, 25

J4:
SERIAL
DATA CHANNEL

J4 PINS N/C: 9-14, 16, 19, 21-25

J2:
KEYBOARD

PROPRIETARY INFORMATION
Not for distribution or transmission to any other person organization or company without the permission of Kaypro Corporation

J3 PINS N/C:
4-6, 8-19, 21-25

J3:
SERIAL
PRINTER

6-32

PWR TO U4: +12V TO PIN 14
GND TO PIN 7
-12V TO PIN 1

QTY REQD	PART OR IDENTIFYING NO.	NOMENCLATURE OR DESCRIPTION	MFR. CODE	CIRCUIT REF.	ITEM NO.
----------	-------------------------	-----------------------------	-----------	--------------	----------

NON-LINEAR SYSTEMS, INC.
DEL MAR, CALIFORNIA

UNLESS OTHERWISE SPECIFIED		CONTR. NO.	
DIMENSIONS ARE IN INCHES		DRAWN	R J
TOLERANCES ON		CHECK	
DECIMALS	± .010	ANGLES	± 0° 30'
FRACTIONS	± 1/32	APPR	R J
MATERIAL		RELEASE DATE	3-6-84/KS
		BOARD REV	A

SCHEMATIC, SERIAL PORTS

KAYPRO 2184

NEXT ASSY.	FINAL ASSY.	NEXT FINAL ASSY.	FINAL ASSY.

SIZE	CODE IDENT NO.	
C	03626	81-295
SCALE	WEIGHT	SHEET 2 E

APPLICATION QTY.

6-33

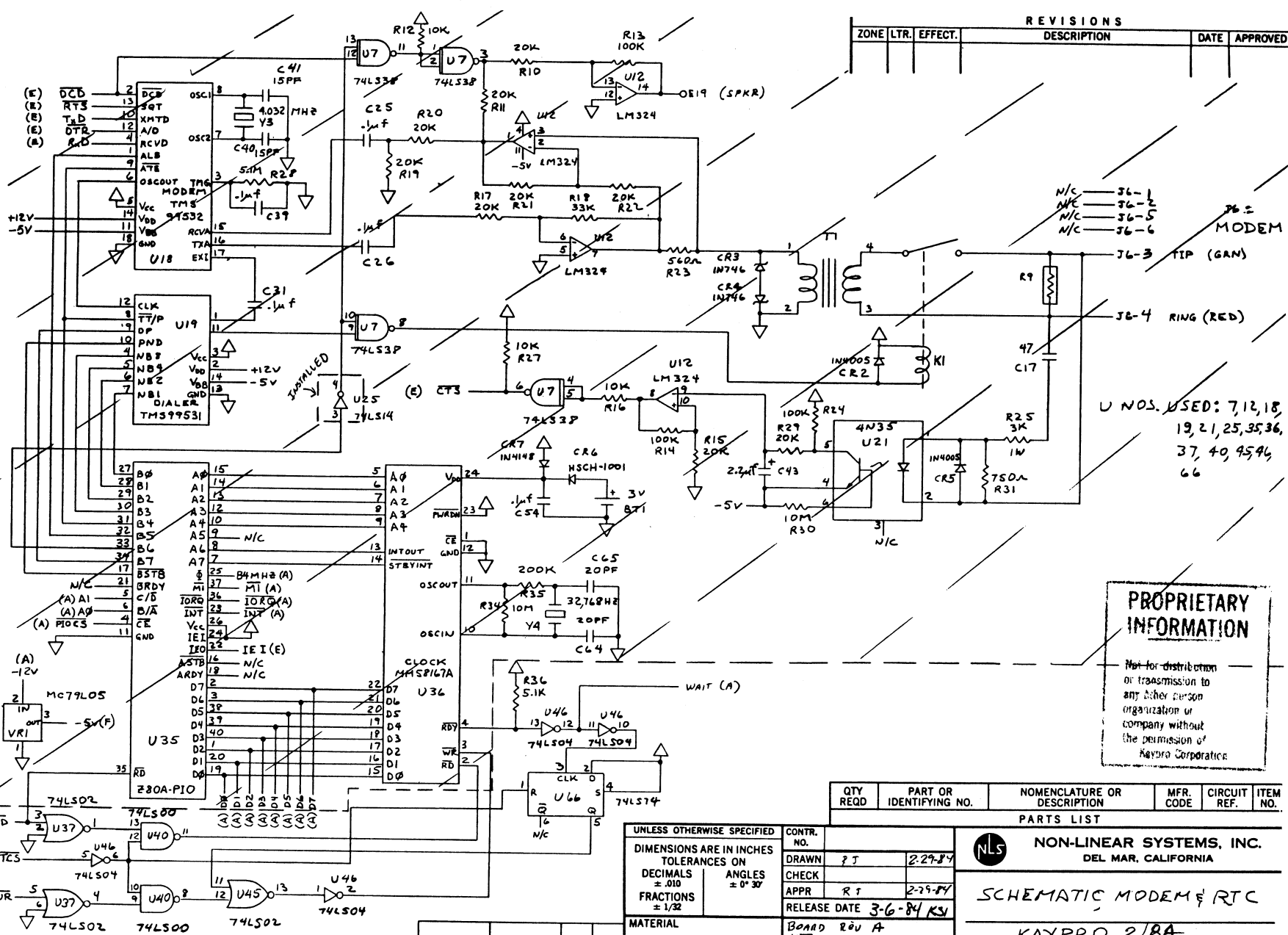

REVISIONS					
ZONE	LTR.	EFFECT.	DESCRIPTION	DATE	APPROVED

N/C = 36-1
 N/C = 36-2
 N/C = 36-5
 N/C = 36-6

36-3 TIP (GAM)
 36-4 RING (RED)
 U NOS. USED: 7, 12, 18,
 19, 21, 25, 35, 36,
 37, 40, 45, 46,
 66

PROPRIETARY INFORMATION
 Not for distribution or transmission to any other person, organization or company without the permission of Kaypro Corporation.

QTY REQD	PART OR IDENTIFYING NO.	NOMENCLATURE OR DESCRIPTION	MFR. CODE	CIRCUIT REF.	ITEM NO.
----------	-------------------------	-----------------------------	-----------	--------------	----------

NLS NON-LINEAR SYSTEMS, INC.
 DEL MAR, CALIFORNIA

SCHEMATIC MODEM & RTC

KAYPRO 2/84

UNLESS OTHERWISE SPECIFIED		CONTR. NO.	
DIMENSIONS ARE IN INCHES		DRAWN	JT 2-27-84
TOLERANCES ON		CHECK	
DECIMALS	± .010	APPR	RT 2-29-84
ANGLES	± 0° 30'	RELEASE DATE	3-6-84 KJ
FRACTIONS	± 1/32	BOARD REV	A
MATERIAL		KIT	
NOTE:		PARTS IN CROSS HATCHED AREA ARE NOT INSTALLED	

NEXT ASSY.	FINAL ASSY.	NEXT FINAL ASSY.	QTY.

SIZE	CODE IDENT NO.	81-295
C	03626	
SCALE	WEIGHT	SHEET 2 F

6.5 KAYPRO 4/84 MAINBOARD (81-184-n)

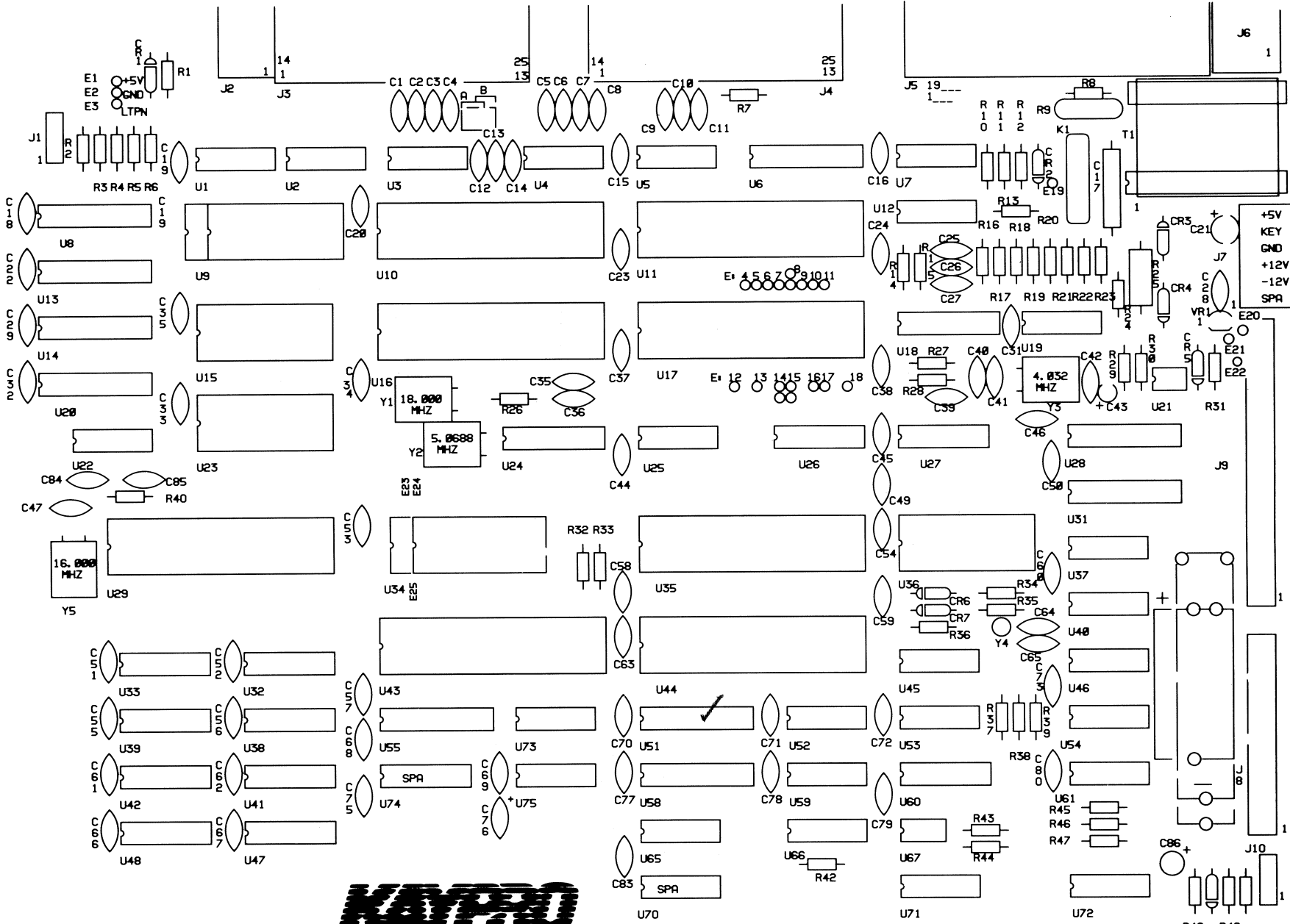

6-34

SER NO. _____

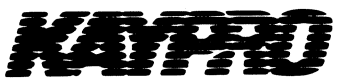

MADE IN U. S. A.

ASSY 81- _____

R48 R49 CR8 R50

IC LIST, 81-184-n

Reference Designation		Description
U1, U54	7406	Hex inverter, open collector
U2, U25, U71	74LS14	Hex Schmitt inverter
U3, U5	1489	Quad Schmitt line driver
U4	1488	Quad line driver
U6, U13, U14, U55, U58	74LS373	Octal "D" latch
U7	74LS38	Positive-NAND buffer
U8	74LS374	Octal "D" flip-flop
U9	81-235	Character PROM (2732)
U10	81-189	Custom gate array
U11, U17	Z80A SIO	
U12	LM324	Op-Amp
U15, U23	6116	Video RAM
U16	6545A	Video controller
U18	TMS 99532	Modem
U19	TMS 99531	Dialer
U20, U31	74LS245	Octal bus transceiver (3-state outputs)
U21	4N35	Photo isolator
U22	3.9K	Pullup resistor, 14-pin DIP
U24	WD1943/ 8116	Dual programmable baud rate generator
U26, U27	74LS138	3/8 MUX
U28, U51	74LS244	Octal buffer/line driver
U29	81-194	Custom gate array
U32, U33, U38, U39, U41, U42, U47, U48	2164	64K x 1 RAM
U34	81-292	Boot PROM (2764)
U35	Z80A PIO	
U36	MM581678	Clock
U37, U45, U59, U72	74LS02	Quad NOR gate
U40	74LS00	Quad NAND gate
U43	Z80A CPU	
<u>U44</u>	<u>1793</u>	<u>Floppy disk controller</u>
U46	74LS04	Hex inverter
U52	74LS32	Quad OR gate
U53, U70, U74, U75		Spares
U60	74LS195	4-bit shift register
U61	74LS08	Quad AND gate
U65	74LS10	Tri NAND gate
U66, U75	74LS74	Dual "D" flip-flop
U67	FDC9216	Data separator
U73	74HC00	Quad NAND gate

6-36

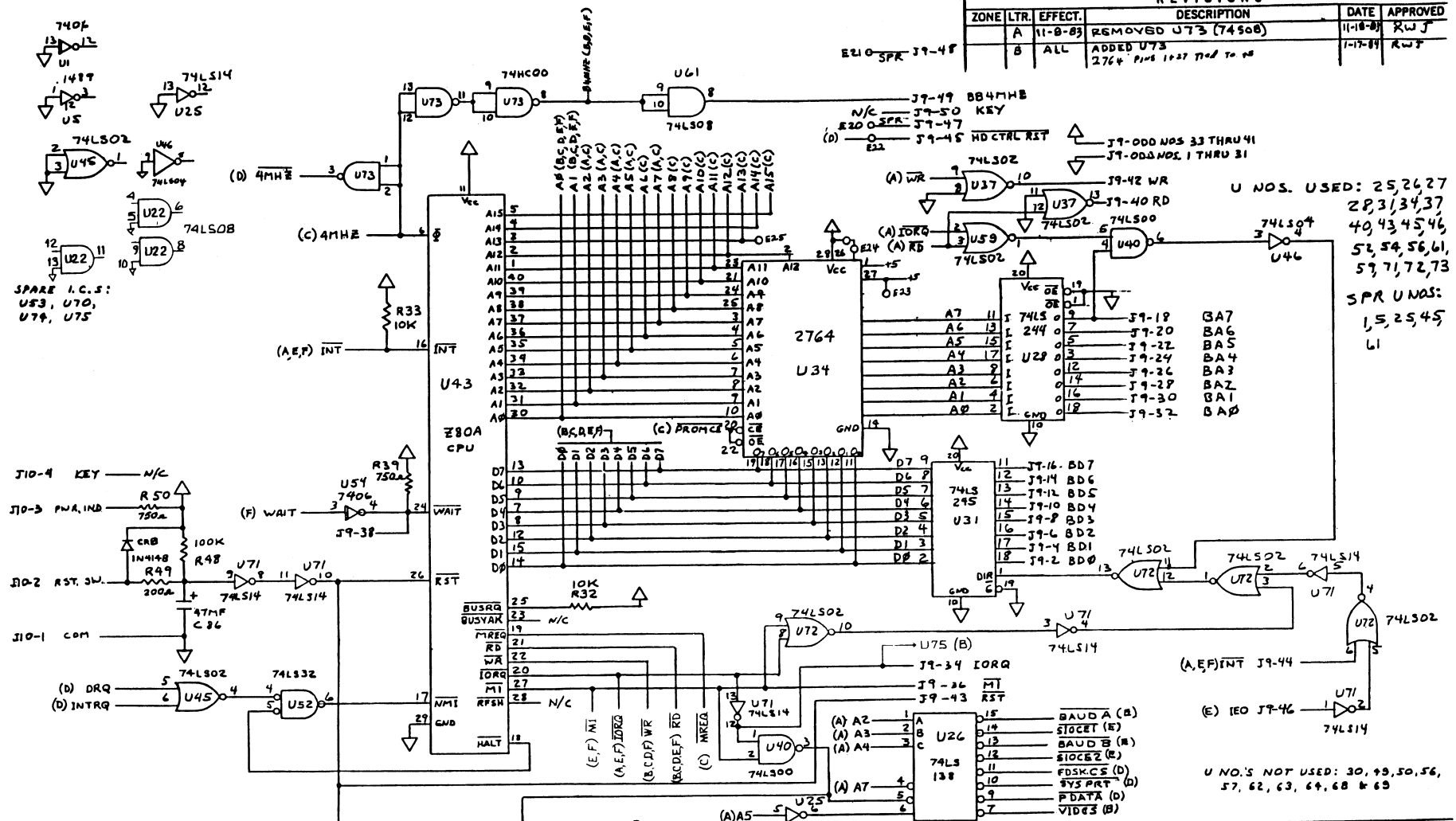

REVISIONS

ZONE	LTR.	EFFECT.	DESCRIPTION	DATE	APPROVED
	A	11-8-83	REMOVED U73 (74508)	11-18-83	KWJ
	B	ALL	ADDED U73 2764 Pin 1 & 27 Tied to Vcc	1-17-84	KWJ

U NOS. USED: 25, 26, 27, 28, 31, 34, 37, 40, 43, 45, 46, 52, 54, 56, 61, 59, 71, 72, 73
SPR UNOS: 1, 5, 25, 45, 61

U NOS NOT USED: 30, 39, 50, 56, 57, 62, 63, 64, 68 & 69

- SPARE J7-1 _____
- 12V J7-2 TO: U4-1
- +12V J7-3 TO: U4-14, U44-4
- GND J7-4 _____
- KEY J7-5 N/C
- +5V J7-6 _____

PROPRIETARY INFORMATION
This document contains information that is the property of Kaypro Corporation. Any other person's reproduction or distribution without the permission of Kaypro Corporation is prohibited.

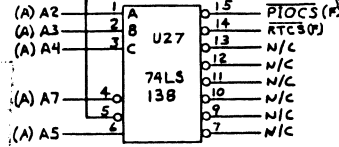

NEXT ASSY.	FINAL ASSY.	NEXT FINAL ASSY.	FINAL ASSY.	QTY.

UNLESS OTHERWISE SPECIFIED		CONTR. NO.	
DIMENSIONS ARE IN INCHES	TOLERANCES ON DECIMALS ± .010	DRAWN	RJS
ANGLES ± 0° 30'	FRACTIONS ± 1/32	CHECK	
		APPR	KWJ
		RELEASE DATE	9-10-83 RSP
MATERIAL		BOARD REV B	(81-184)

QTY REQD	PART OR IDENTIFYING NO.	NOMENCLATURE OR DESCRIPTION	MFR. CODE	CIRCUIT REF.	ITEM NO.
----------	-------------------------	-----------------------------	-----------	--------------	----------

NON-LINEAR SYSTEMS, INC.
DEL MAR, CALIFORNIA

SCHEMATIC, PROCESSOR

KAYPRO 4/84

SIZE	CODE IDENT NO.	81-185
C	03626	

SCALE | WEIGHT | SHEET 2A

6-37

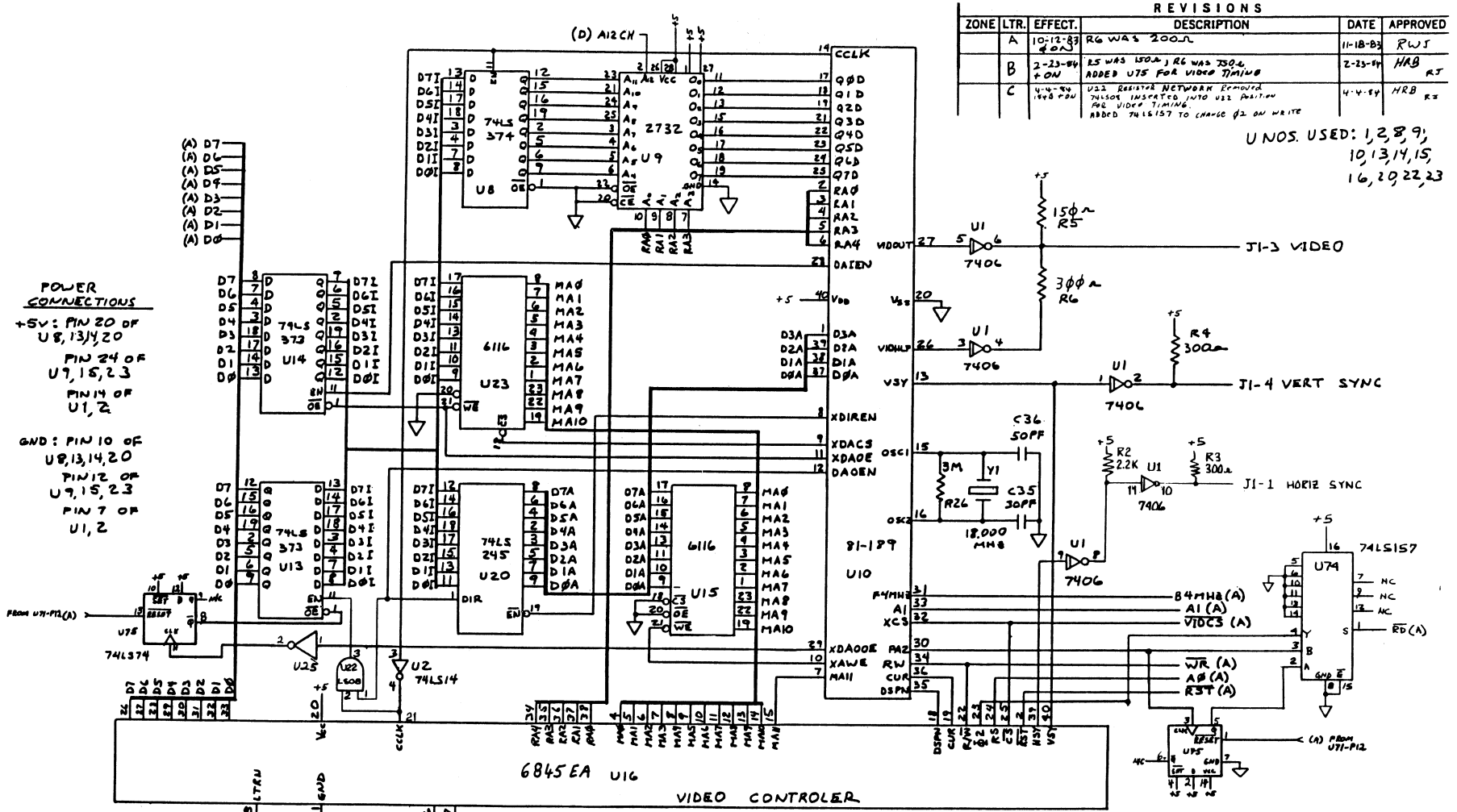

POWER CONNECTIONS
 +5V: PIN 20 OF U8, 13, 14, 20
 PIN 24 OF U7, 15, 23
 PIN 14 OF U1, 2
 GND: PIN 10 OF U8, 13, 14, 20
 PIN 12 OF U7, 15, 23
 PIN 7 OF U1, 2

PROPRIETARY INFORMATION
 Not for distribution or transmission to any other person, organization or company without the permission of the Kaypro Corporation.

REVISIONS					
ZONE	LTR.	EFFECT.	DESCRIPTION	DATE	APPROVED
A	10-12-83	RJA	R6 WAS 200Ω	11-18-83	RWJ
B	2-23-84	RON	R5 WAS 150Ω, R6 WAS 350Ω, ADDED U75 FOR VIDEO TIMING	2-23-84	HAB RJ
C	4-4-84	WES	U22 REGISTER NETWORK REMOVED 74LS08 INSTALLED INTO U22 POSITION FOR VIDEO TIMING. ADDED 74LS157 TO CHANGE Q2 ON WRITE	4-4-84	HRB RJ

UNOS. USED: 1, 2, 8, 9, 10, 13, 14, 15, 16, 20, 22, 23

QTY REQD	PART OR IDENTIFYING NO.	NOMENCLATURE OR DESCRIPTION	MFR. CODE	CIRCUIT REF.	ITEM NO.
----------	-------------------------	-----------------------------	-----------	--------------	----------

UNLESS OTHERWISE SPECIFIED		CONTR. NO.	
DIMENSIONS ARE IN INCHES		DRAWN	RJ
TOLERANCES ON DECIMALS = .010		CHECK	
ANGLES = 0° 30'		APPR	RWJ
FRACTIONS = 1/32		RELEASE DATE	9-20-83 KSP
MATERIAL		BOARD REV B	
		(81-184)	
NEXT ASSY.	FINAL ASSY.	NEXT ASSY.	FINAL ASSY.
APPLICATION		QT	

NON-LINEAR SYSTEMS, INC. DEL MAR, CALIFORNIA			
SCHEMATIC, VIDEO			
KAYPRO 4/84			
SIZE	CODE IDENT NO.		
C	03626	81-185	
SCALE	WEIGHT	28	

6-38

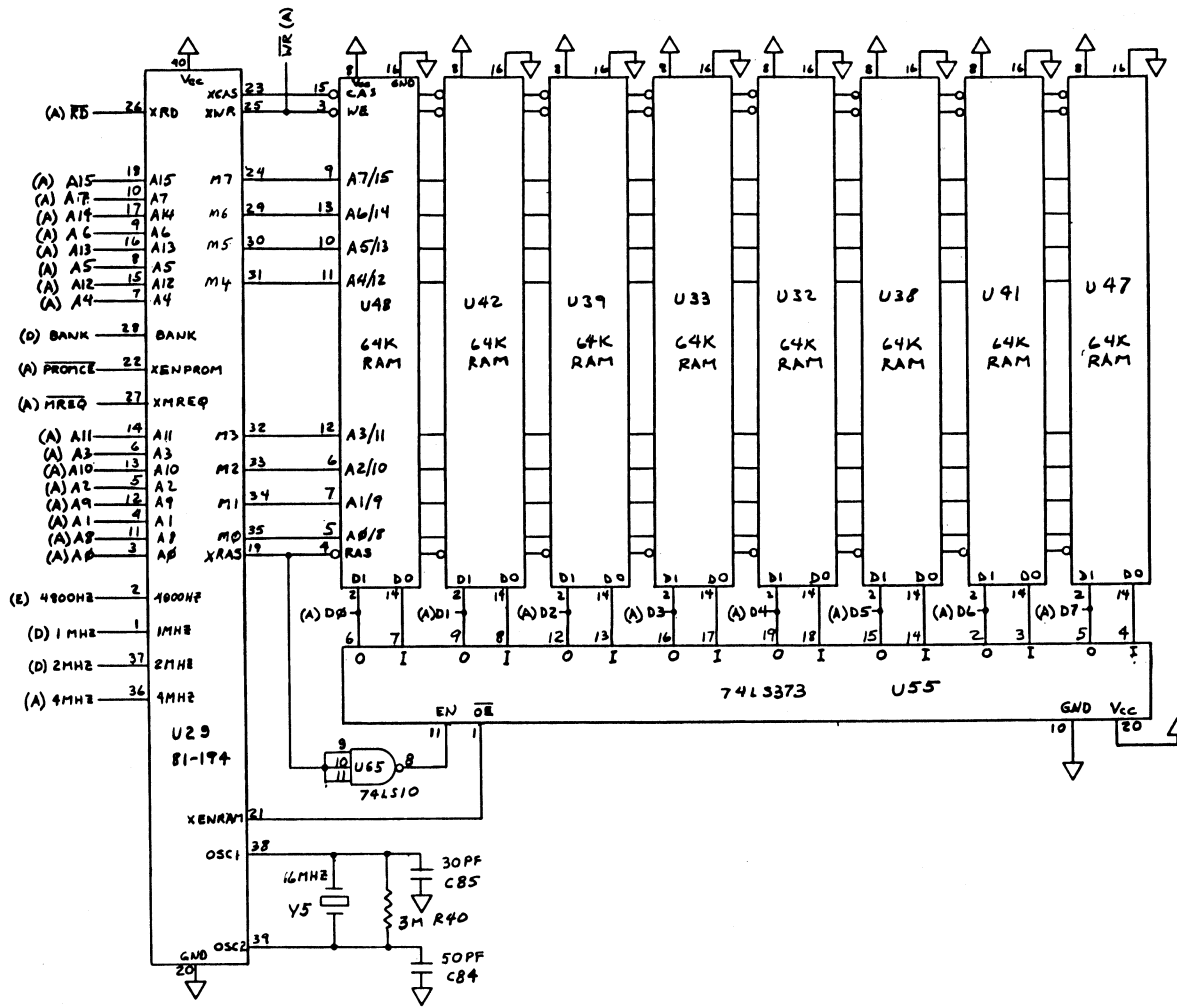

REVISIONS					
ZONE	LTR.	EFFECT.	DESCRIPTION	DATE	APPROVED

UNOS USED: 29, 48, 42,
39, 33, 32, 38, 41, 47, 55,
65

PROPRIETARY INFORMATION
Not for distribution or transmission to any other person or organization or company without the permission of Kaypro Corporation

QTY REQD	PART OR IDENTIFYING NO.	NOMENCLATURE OR DESCRIPTION	MFR. CODE	CIRCUIT REF.	ITEM NO.
PARTS LIST					

UNLESS OTHERWISE SPECIFIED		CONTR. NO.	
DIMENSIONS ARE IN INCHES		DRAWN	RJ 9-1-83
TOLERANCES ON		CHECK	
DECIMALS ± .010	ANGLES ± 0° 30'	APPR	RJ 9-16-83
FRACTIONS ± 1/32		RELEASE DATE	1-20-83 KSP

NLS NON-LINEAR SYSTEMS, INC.
DEL MAR, CALIFORNIA

SCHEMATIC, RAM
KAYPRO 4/84

SIZE	CODE IDENT NO.	
C	03626	81-185
SCALE	WEIGHT	SHEET 2 C

APPLICATION	QTY.
NEXT ASSY.	
FINAL ASSY.	
NEXT FINAL ASSY.	

BOARD REV B
(81-184)

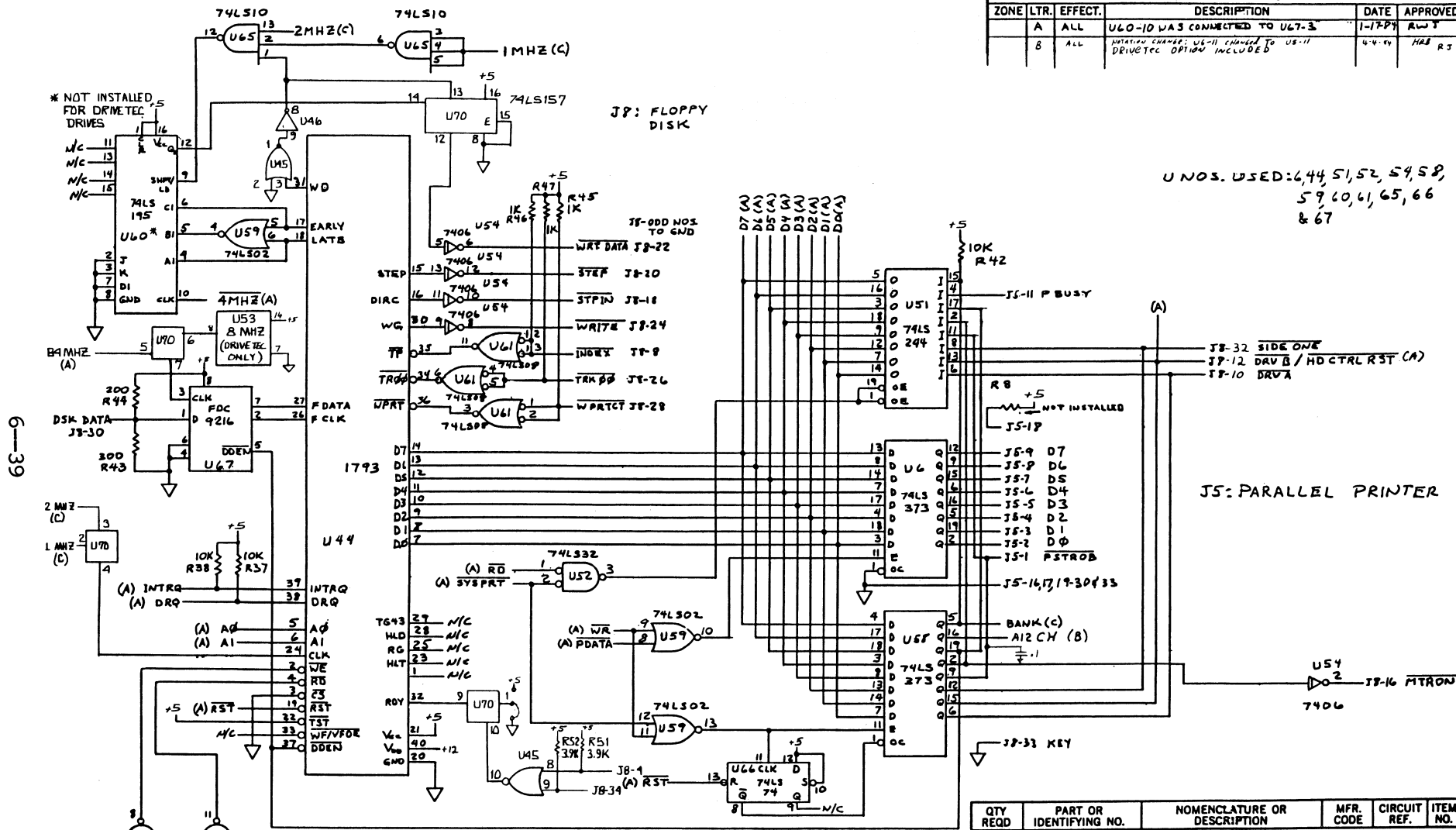

6-39

REVISIONS					
ZONE	LTR.	EFFECT.	DESCRIPTION	DATE	APPROVED
	A	ALL	U60-10 WAS CONNECTED TO U67-3	1-78	RWT
	B	ALL	INITIAL CHANGE: U6-11 CHANGED TO U5-11 DRIVETEC OPTION INCLUDED	4-4-79	HAS RJ

U NOS. USED: 6, 44, 51, 52, 54, 58,
59, 60, 61, 65, 66
& 67

J5: PARALLEL PRINTER

PROPRIETARY INFORMATION
Not for distribution or transmission to any other person, organization or company without the permission of Kaypro Corporation.

APPLICATION	QTY.
NEXT ASSY.	FINAL ASSY.
NEXT FINAL ASSY.	FINAL ASSY.

UNLESS OTHERWISE SPECIFIED		CONTR. NO.
DIMENSIONS ARE IN INCHES		
TOLERANCES ON		
DECIMALS ± .010	ANGLES ± 0° 30'	DRAWN RJ 9-4-83
FRACTIONS ± 1/32		CHECK APPR RWT 9-5-83
MATERIAL		RELEASE DATE 9-20-83 K5
		Bored Rev B (81-184)

QTY REQD	PART OR IDENTIFYING NO.	NOMENCLATURE OR DESCRIPTION	MFR. CODE	CIRCUIT REF.	ITEM NO.
PARTS LIST					
NON-LINEAR SYSTEMS, INC. DEL MAR, CALIFORNIA					
SCHEMATIC, FLOPPY CONTROL & PARALLEL PRINTER					
KAYPRO 4/84					
SIZE	CODE IDENT NO.				
C	03626	81-185			
SCALE	WEIGHT	SHEET 2 D			

REVISIONS

ZONE	LTR.	EFFECT.	DESCRIPTION	DATE	APPROVED
	A	1948	"B" JUMPPES INSTALLED IN FOIL	3-21-74	HRB RJT

U NOS. USED: 2,3,4,5,11
17,24,25

J4:
SERIAL
DATA CHANNEL

J4 PINS N/C: 9-14,16,19,21-25

J2:
KEYBOARD

PROPRIETARY INFORMATION
Not for distribution or transmission to any other person organization or company without the permission of Kaypro Corporation

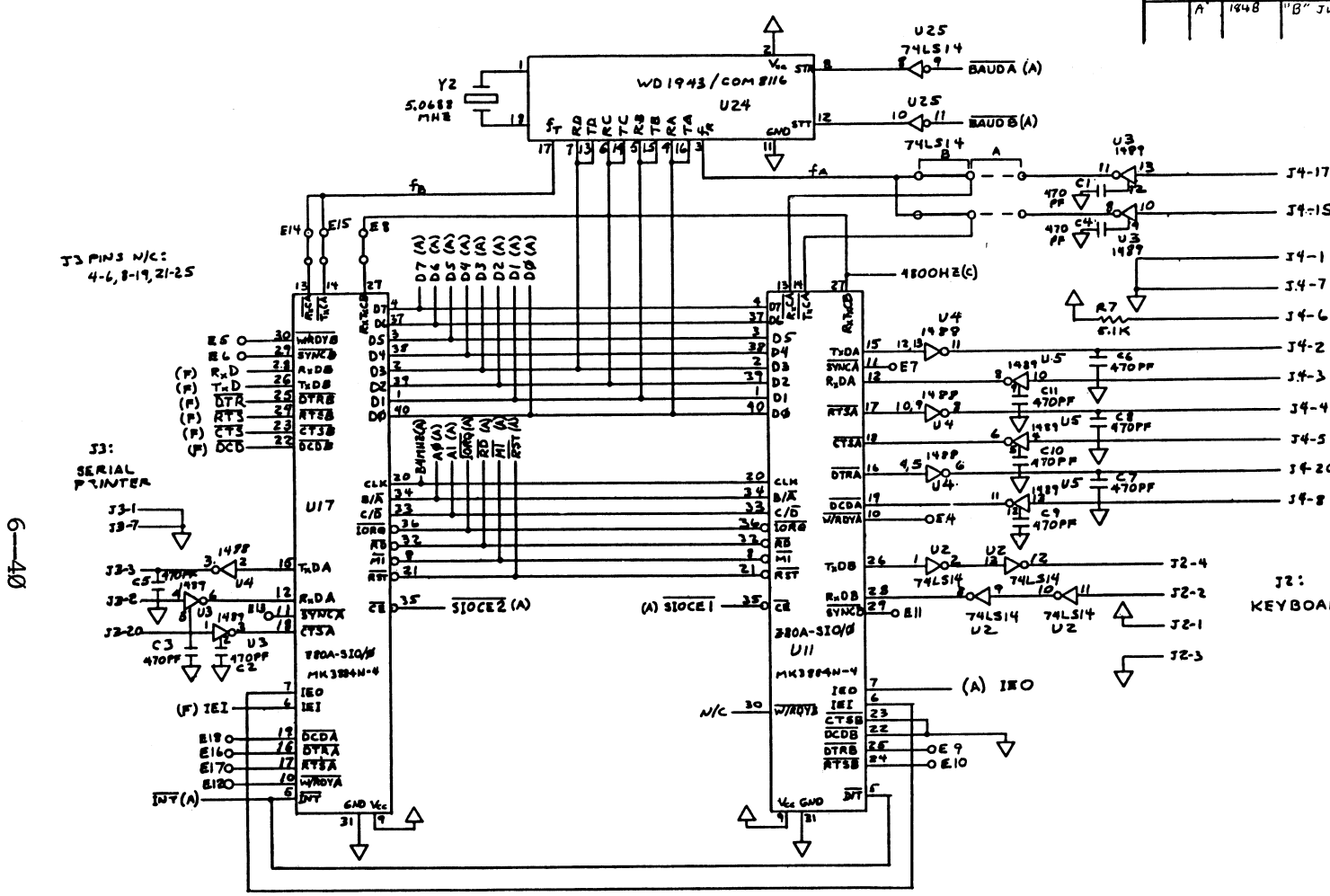

J3 PINS N/C:
4-6,8-19,21-25

J3:
SERIAL
PRINTER

PWR TO U4: +12V TO PIN 14
GND TO PIN 7
-12V TO PIN 1

QTY REQD	PART OR IDENTIFYING NO.	NOMENCLATURE OR DESCRIPTION	MFR. CODE	CIRCUIT REF.	ITEM NO.
----------	-------------------------	-----------------------------	-----------	--------------	----------

PARTS LIST
NON-LINEAR SYSTEMS, INC.
DEL MAR, CALIFORNIA

UNLESS OTHERWISE SPECIFIED
DIMENSIONS ARE IN INCHES
TOLERANCES ON
DECIMALS ± .010
FRACTIONS ± 1/32
ANGLES ± 0° 30'

CONTR. NO.	
DRAWN	R J 7-3-82
CHECK	
APPR	R W J 9-5-83
RELEASE DATE	9-30-83 KSP

SCHMATIC, SERIAL PORTS

KAYPRO 4/84

SIZE	CODE IDENT NO.	
C	03626	81-185

SCALE | WEIGHT | SHEET 2 E

APPLICATION	QTY.
NEXT ASSY.	
FINAL ASSY.	
NEXT FINAL ASSY.	

6-40

REVISIONS					
ZONE	LTR.	EFFECT.	DESCRIPTION	DATE	APPROVED
TR-1017	B	1848	CHANGED VALUE OF C54 TO 4.7UF CHANGED PWR DOWN CIRCUIT REMOVED R10, R13	4-22-79	NRB
	A	1844	CHANGED WAIT CIRCUIT	2-20-79	NRB

6-41

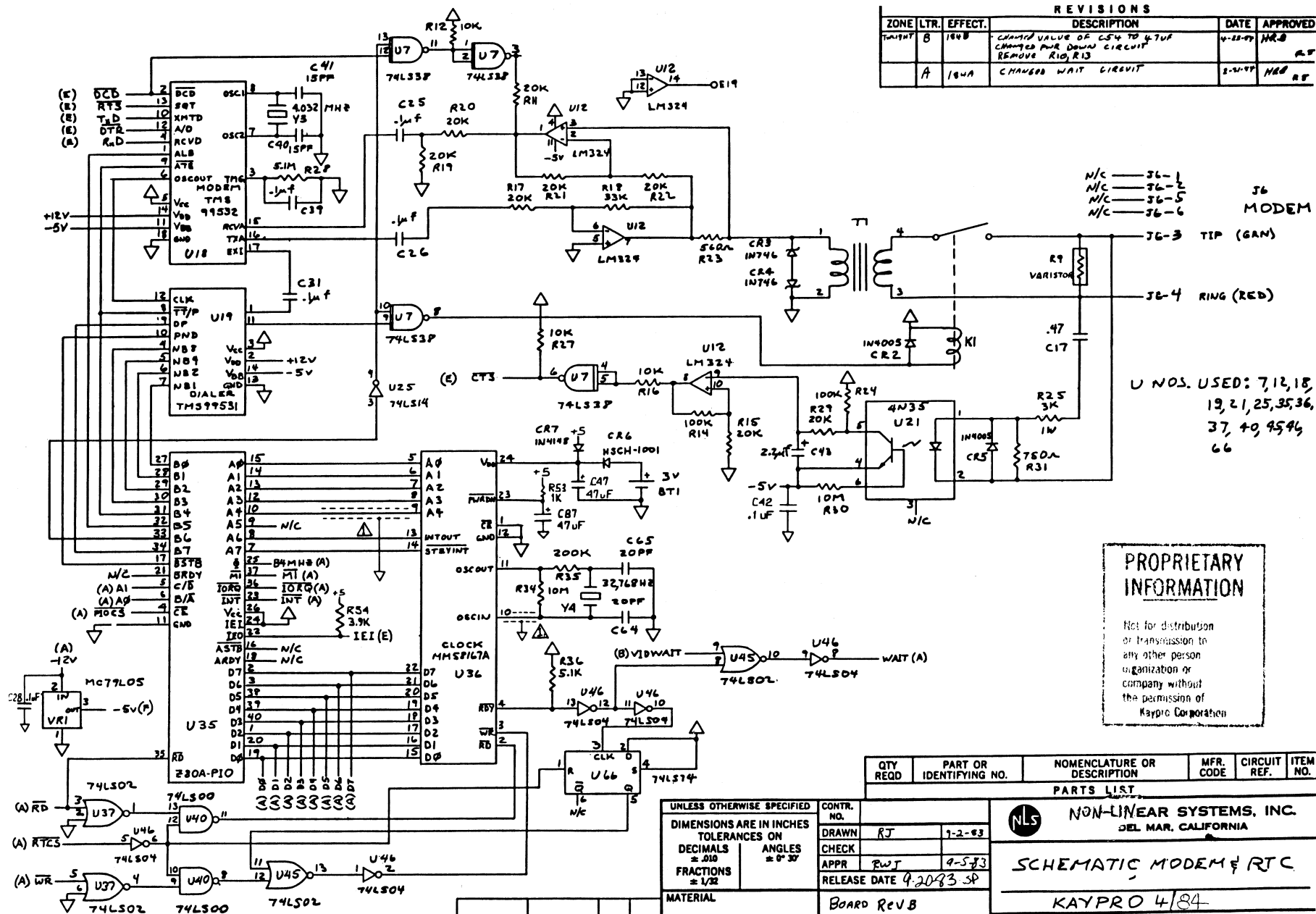

N/C — 36-1
N/C — 36-2
N/C — 36-5
N/C — 36-6

J6
MODEM

J6-3 TIP (GRN)
J6-4 RING (RED)

U NOS. USED: 7, 12, 18,
19, 21, 25, 35, 36,
37, 40, 45, 46,
66

PROPRIETARY INFORMATION

Not for distribution or transmission to any other person, organization or company without the permission of Kaypro Corporation.

QTY REQD	PART OR IDENTIFYING NO.	NOMENCLATURE OR DESCRIPTION	MFR. CODE	CIRCUIT REF.	ITEM NO.
----------	-------------------------	-----------------------------	-----------	--------------	----------

NON-LINEAR SYSTEMS, INC.
DEL MAR, CALIFORNIA

SCHEMATIC MODEM & RTC

KAYPRO 4/84

SIZE	CODE IDENT NO.	
C	03626	81-185
SCALE	WEIGHT	SHEET 2 F

UNLESS OTHERWISE SPECIFIED
DIMENSIONS ARE IN INCHES
TOLERANCES ON
DECIMALS ±.010
FRACTIONS ±1/32
ANGLES ±0°30'

CONTR. NO.	
DRAWN	RJ 7-2-83
CHECK	
APPR	RWT 9-5-83
RELEASE DATE	4.20.83 SP

MATERIAL

BOARD REV B
(81-184)

APPLICATION	QTY.
NEXT ASSY.	
FINAL ASSY.	
NEXT FINAL ASSY.	

NOTES: 1 SHIELDED BY 2 ADJACENT GROUNDED TRACES.

6.6 KAYPRO ROBITE (81-296-n)

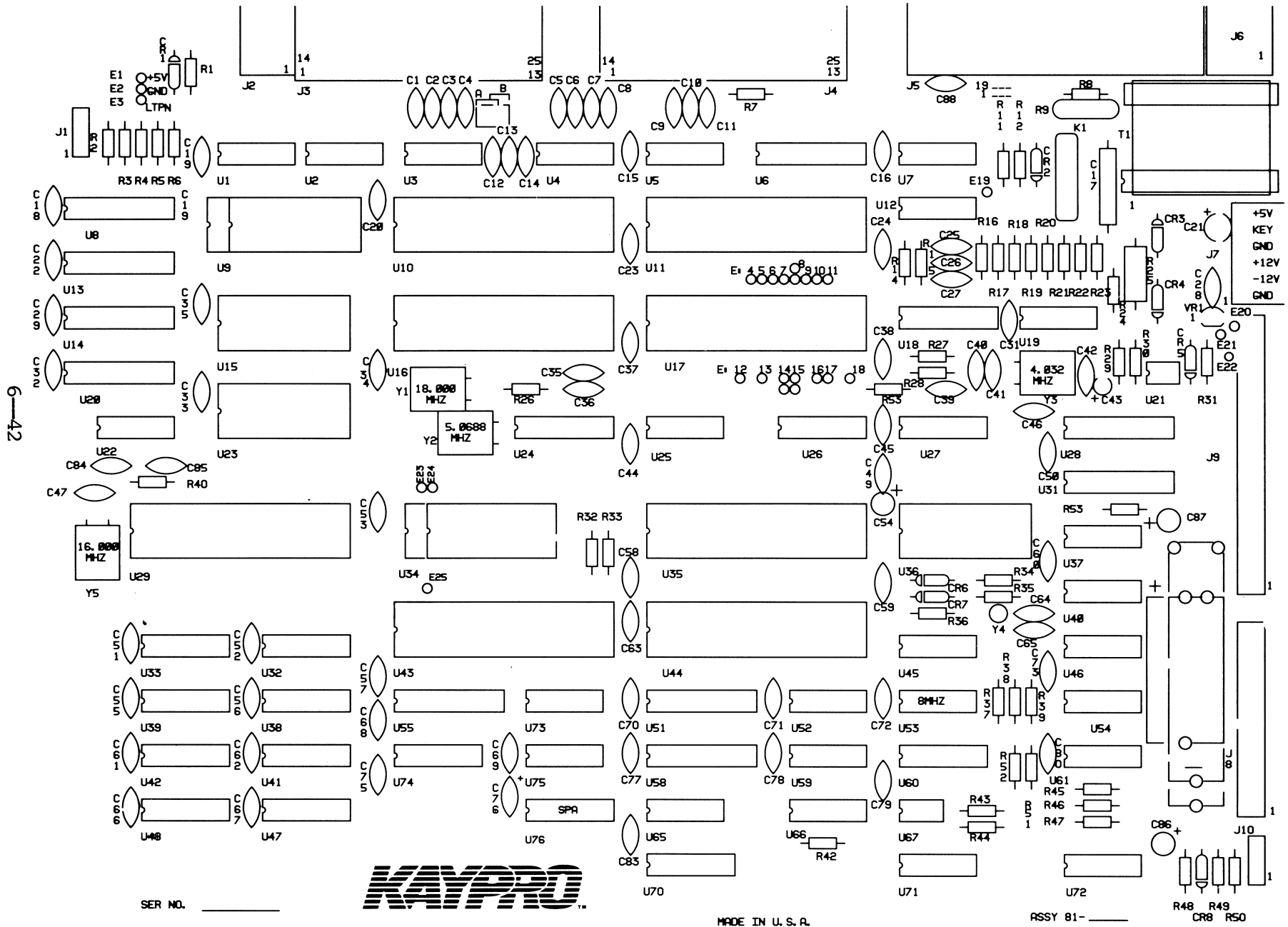

6-42

SER NO. _____



MADE IN U.S.A.

ASSY 81- _____

R48 R49
CR8 R50

IC LIST, 81-296-n

Reference Designation		Description
U1, U54	7406	Hex inverter, open collector
U2, U25, U71	74LS14	Hex Schmitt inverter
U3, U5	1489	Quad Schmitt line driver
U4	1488	Quad line driver
U6, U13, U14, U55, U58	74LS373	Octal "D" latch
U7	74LS38	Positive-NAND buffer
U8	74LS374	Octal "D" flip-flop
U9	81-235	Character PROM (2732)
U10	81-189	Custom gate array
U11, U17	Z80A SIO	
U12	LM324	Op-Amp
U15, U23	6116	Video RAM
U16	6545EA	Video controller
U18	TMS 99532	Modem
U19	TMS 99531	Dialer
U20, U31	74LS245	Octal bus transceiver
U21	4N35	Photo Isolator
U22	3.9K	Pullup resistor, 14-pin DIP
U24	WD1943/ 8116	Dual programmable baud rate generator
U26, U27	74LS138	3/8 MUX
U28, U51	74LS244	Octal buffer/line driver
U29	81-194	Custom gate array
U32, U33, U38, U39, U41, U42, U47, U48	2164	64K x 1 RAM
U34	81-326	Boot PROM (2764)
U35	Z80A PIO	
U36	MM581678	Clock
U37, U45, U59, U72	74LS02	Quad NOR gate
U40	74LS00	Quad NAND gate
U43	Z80A CPU	
U44	1793	Floppy disk controller
U46	74LS04	Hex inverter
U52	74LS32	Quad OR gate
U70, U74, U75		Spares
U60	74LS195	4-bit shift register
U61	74LS08	Quad AND gate
U65	74LS10	Tri NAND gate
U66, U75	74LS74	Dual "D" flip-flop
U67	FDC9216	Data separator
U73	74HC00	Quad NAND gate

6-44

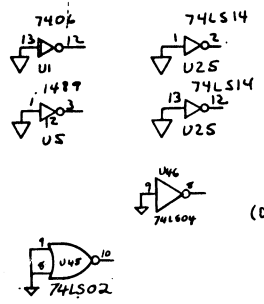

SPARE I.C.'S:
U53, U70,
U74, U75

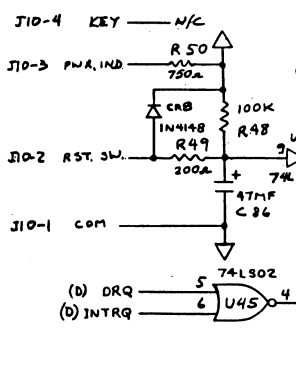

- SPARE J7-1 _____
-12V J7-2 TO: U4-1
+12V J7-3 TO: U4-14, U44-40
GND J7-4 _____
KEY J7-5 _____
+5V J7-6 _____

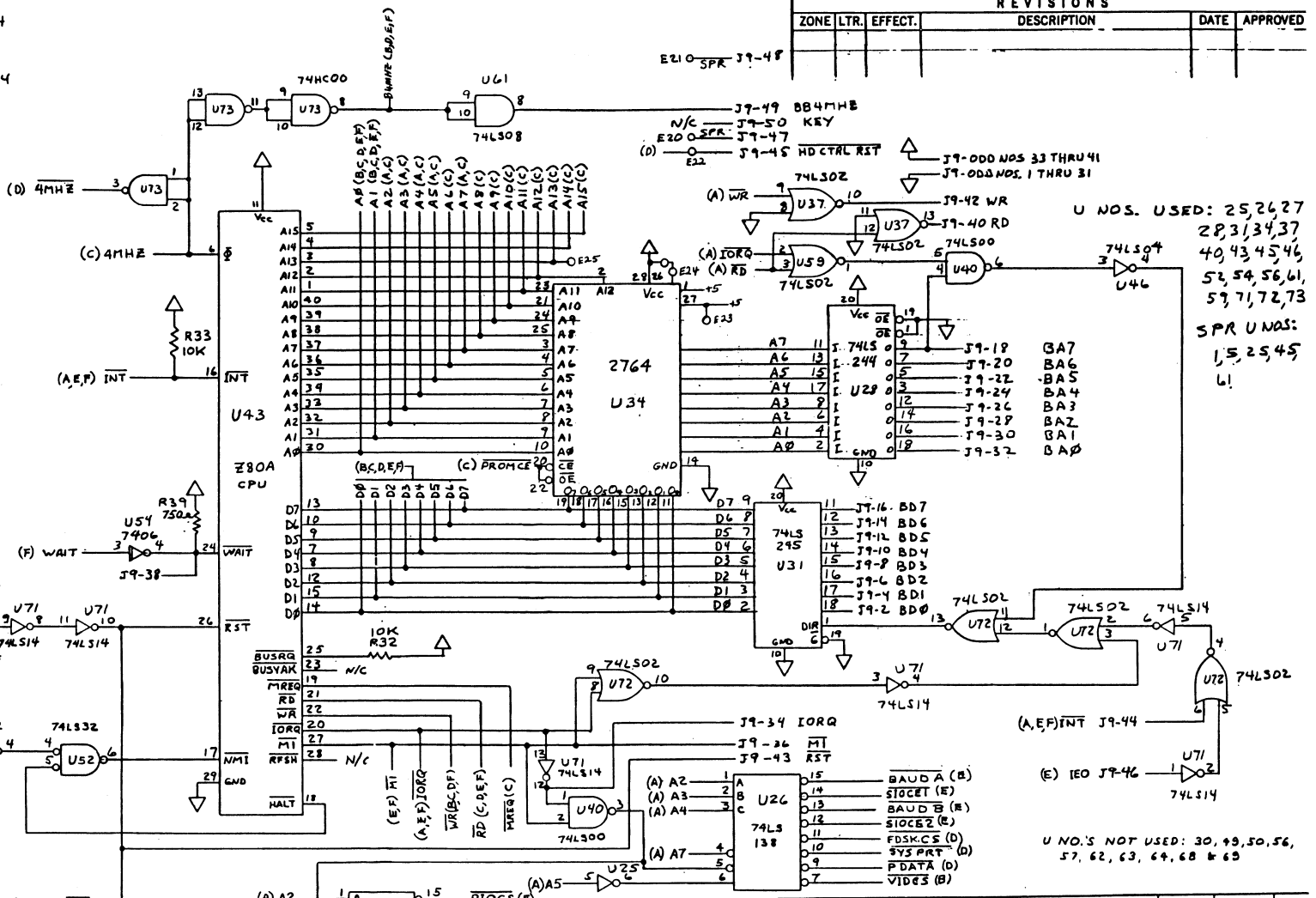

PROPRIETARY INFORMATION
Not for distribution or transmission to any other person, organization or company without the permission of Kaypro Corporation.

(A) A2	1	A	15	PIOC3 (P)
(A) A3	2	B	14	RTCS (P)
(A) A4	3	C	13	N/C
			12	N/C
			11	N/C
			10	N/C
			9	N/C
			8	N/C
(A) A5	4	5	7	N/C

UNLESS OTHERWISE SPECIFIED		CONTR. NO.	
DIMENSIONS ARE IN INCHES		DRAWN	R J
TOLERANCES ON DECIMALS ± .010		CHECK	
FRACTIONS ± 1/32		APPR	R J
MATERIAL		RELEASE DATE	3-6-81 KSI
NEXT ASSY.		BOARD:	81-184 A
FINAL ASSY.			
NEXT FINAL ASSY.			
APPLICATION			
QTY.			

QTY REQD	PART OR IDENTIFYING NO.	NOMENCLATURE OR DESCRIPTION	MFR. CODE	CIRCUIT REF.	ITEM NO.
PARTS LIST					
NON-LINEAR SYSTEMS, INC. DEL MAR, CALIFORNIA					
SCHEMATIC PROCESSOR ROBIE					
SIZE	CODE IDENT NO.	81-297			
C	03626				
SCALE	WEIGHT	SHEET 2A			

REVISIONS					
ZONE	LTR.	EFFECT.	DESCRIPTION	DATE	APPROVED
E210	SPR	J9-48			

U NOS. USED: 25, 26, 27
28, 31, 34, 37
40, 43, 45, 46
53, 54, 56, 61
59, 71, 72, 73
SPR UNOS:
1, 5, 25, 45
61

U NOS. NOT USED: 30, 39, 50, 56,
57, 62, 63, 64, 68 & 69

6-45

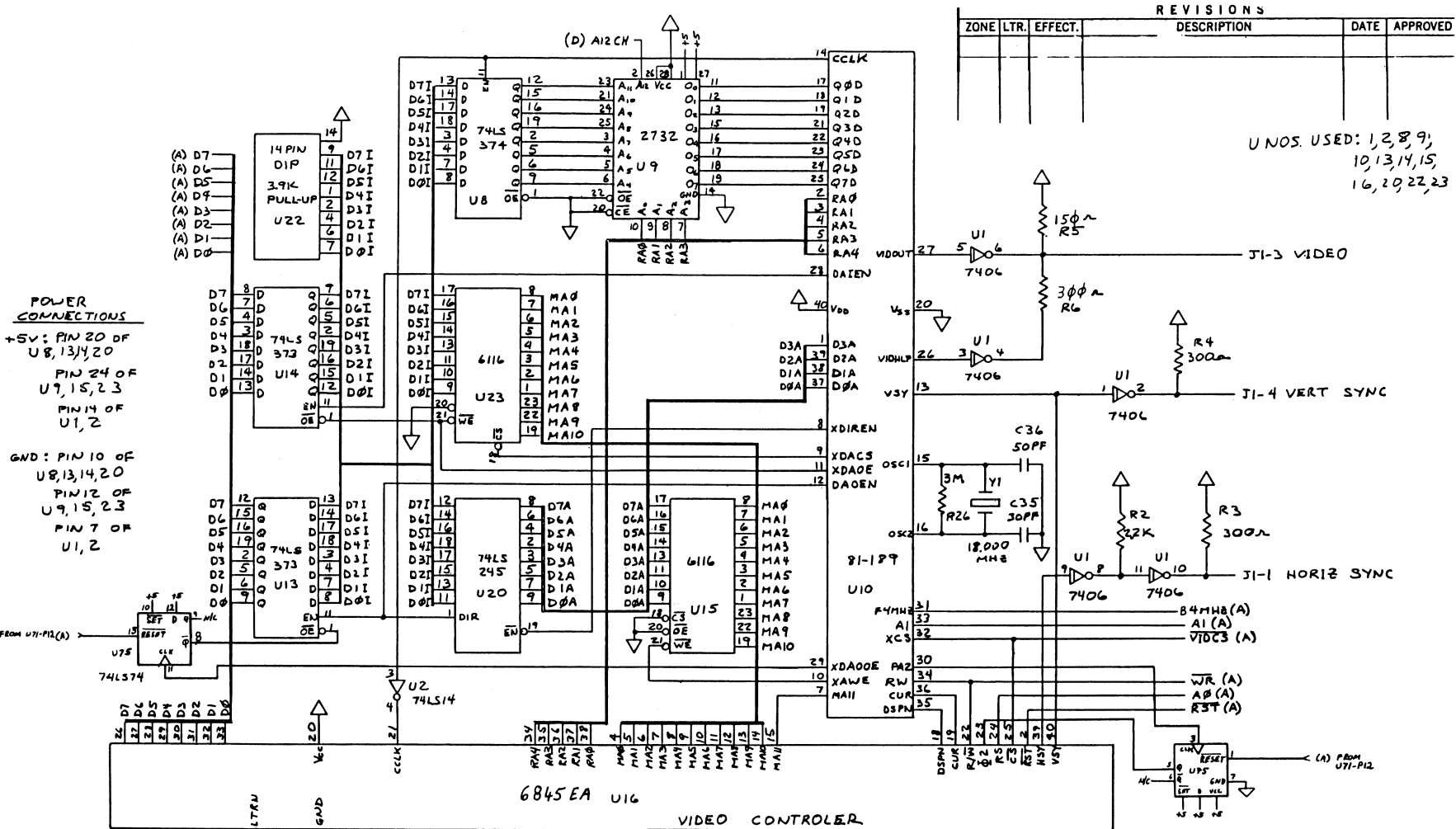

POWER CONNECTIONS
 +5V: PIN 20 OF U 8, 13, 14, 20
 PIN 24 OF U 7, 15, 23
 PIN 14 OF U 1, 2
 GND: PIN 10 OF U 8, 13, 14, 20
 PIN 12 OF U 9, 15, 23
 PIN 7 OF U 1, 2

REVISIONS					
ZONE	LTR.	EFFECT.	DESCRIPTION	DATE	APPROVED

UNOS. USED: 1, 2, 8, 9,
 10, 13, 14, 15,
 16, 20, 22, 23

PROPRIETARY INFORMATION
 Not for distribution or transmission to any other person, organization or company without the permission of Kaypro Corporation

QTY REQD	PART OR IDENTIFYING NO.	NOMENCLATURE OR DESCRIPTION	MFR. CODE	CIRCUIT REF.	ITEM NO.
----------	-------------------------	-----------------------------	-----------	--------------	----------

NON-LINEAR SYSTEMS, INC.
 DEL MAR, CALIFORNIA

UNLESS OTHERWISE SPECIFIED	CONTR. NO.	
DIMENSIONS ARE IN INCHES	DRAWN	RJ 4-143
TOLERANCES ON	CHECK	
DECIMALS ± .010	APPR	RWJ 9-12-83
ANGLES ± 0° 30'	RELEASE DATE	3-6-84 KSI
FRACTIONS ± 1/32	MATERIAL	BOARD: 81-124A

SCHEMATIC, VIDEO

ROBIE

SIZE	CODE IDENT NO.	
C	03626	81-297

APPLICATION	NEXT ASSY.	FINAL ASSY.	NEXT FINAL ASSY.	FINAL ASSY.

REVISIONS					
ZONE	LTR.	EFFECT.	DESCRIPTION	DATE	APPROVED

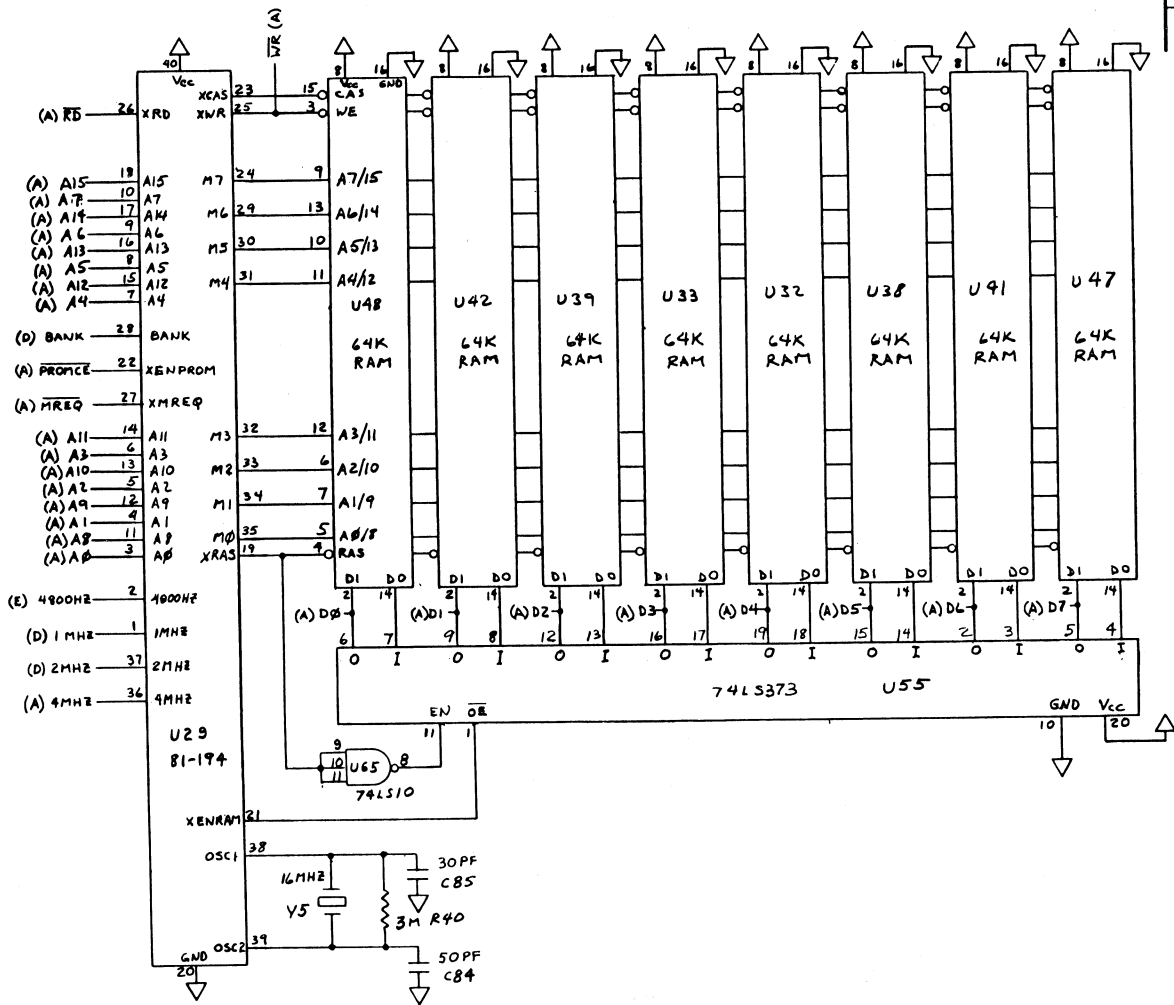

UNOS USED: 29, 48, 42,
39, 33, 32, 38, 41, 47, 55,
65

6-46

PROPRIETARY INFORMATION

Not for distribution or transmission to any other person, organization or company without the permission of Raypro Corporation

QTY REQD	PART OR IDENTIFYING NO.	NOMENCLATURE OR DESCRIPTION	MFR. CODE	CIRCUIT REF.	ITEM NO.
----------	-------------------------	-----------------------------	-----------	--------------	----------

PARTS LIST

NON-LINEAR SYSTEMS, INC.
DEL MAR, CALIFORNIA

UNLESS OTHERWISE SPECIFIED		CONTR. NO.	
DIMENSIONS ARE IN INCHES		DRAWN	RJ 7-1-83
TOLERANCES ON		CHECK	
DECIMALS	± .010	ANGLES	± 0° 30'
FRACTIONS	± 1/32	APPR	RJ 7-16-83
		RELEASE DATE	3-6-84 KSI

SCHEMATIC, RAM

ROBIE

NEXT ASSY.	FINAL ASSY.	NEXT ASSY.	FINAL ASSY.
APPLICATION		QTY.	

MATERIAL	BOARD: 81-184A
SIZE	CODE IDENT NO.
C	03626
	81-297
SCALE	WEIGHT
	SHEET 2 C

REVISIONS					
ZONE	LTR.	EFFECT.	DESCRIPTION	DATE	APPROVED

UNOS. USED: 6, 4, 5, 1, 5, 2, 5, 4, 5, 8,
5, 9, 10, 4, 1, 6, 5, 6, 6
& 67

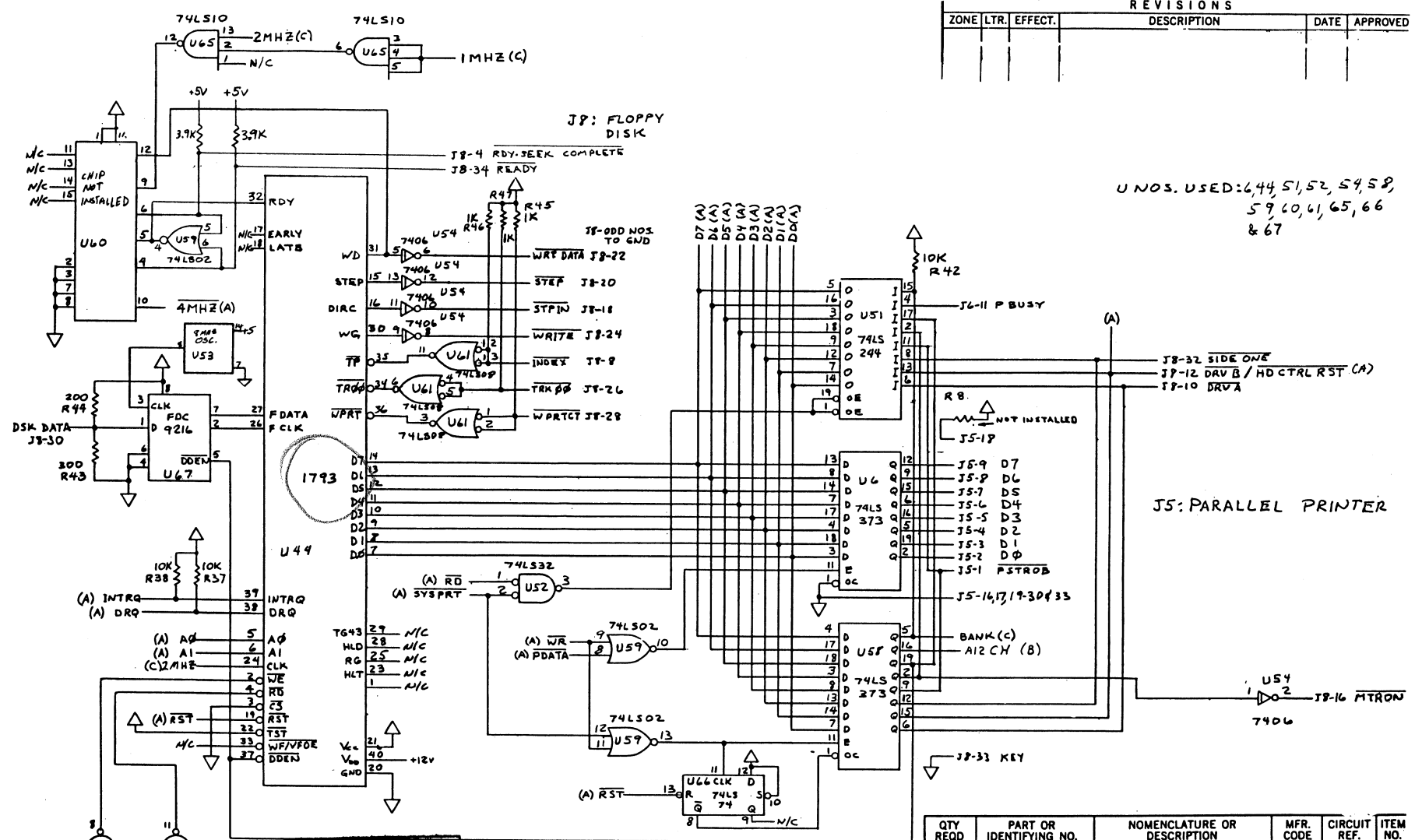

6-47

PROPRIETARY INFORMATION

Not for distribution or transmission to any other person, organization or company without the permission of Kaypro Corporation

QTY REQD	PART OR IDENTIFYING NO.	NOMENCLATURE OR DESCRIPTION	MFR. CODE	CIRCUIT REF.	ITEM NO.

UNLESS OTHERWISE SPECIFIED		CONTR. NO.	
DIMENSIONS ARE IN INCHES		DRAWN	RJ 9-4-83
TOLERANCES ON		CHECK	
DECIMALS ±.010	ANGLES ±0°30'	APPR	RJ 9-15-83
FRACTIONS ±1/32		RELEASE DATE	3-6-84 KSI
MATERIAL		BOARD: 81-184A	
NEXT ASSY.	FINAL ASSY.	NEXT FINAL ASSY.	FINAL ASSY.
APPLICATION	QTY.		

PARTS LIST			
NON-LINEAR SYSTEMS, INC. DEL MAR, CALIFORNIA			
SCHEMATIC, FLOPPY CONTROL & PARALLEL PRINTER			
ROBIE			
SIZE	CODE IDENT NO.	81-297	
C	03626		
SCALE	WEIGHT	SHEET 2 D	

REVISIONS					
ZONE	LTR.	EFFECT.	DESCRIPTION	DATE	APPROVED

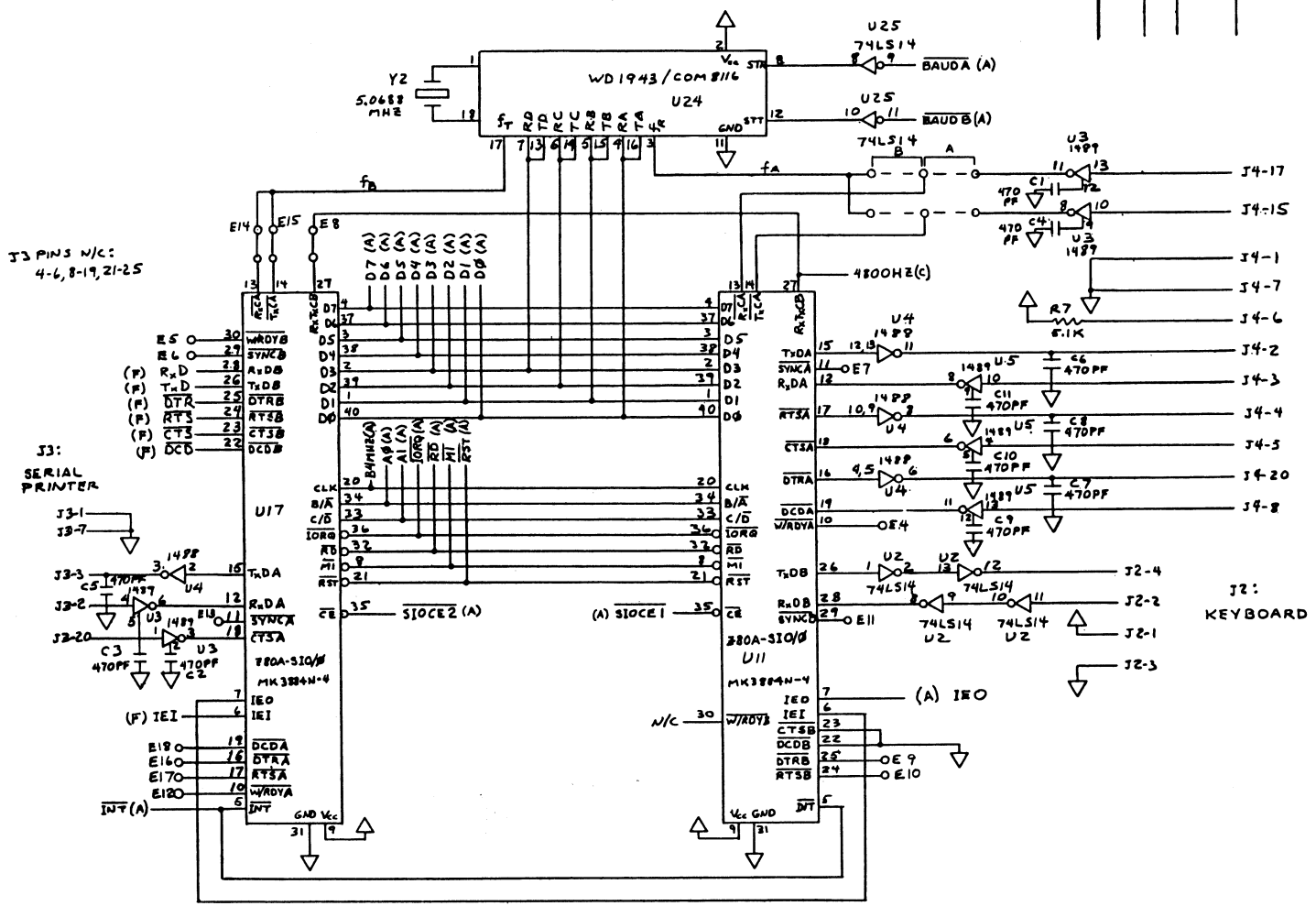

U NOS. USED: 2,3,4,5,11
17,24,25

J4:
SERIAL
DATA CHANNEL

J4 PINS N/C: 9-14,16,19,21-25

J2:
KEYBOARD

J3 PINS N/C:
4-6,8-19,21-25

J3:
SERIAL
PRINTER

**PROPRIETARY
INFORMATION**

Not for distribution
or transmission to
any other person
organization or
company without
the permission of
Kaypro Corporation

PWR TO U4: +12V TO PIN 14
GND TO PIN 7
-12V TO PIN 1

QTY REQD	PART OR IDENTIFYING NO.	NOMENCLATURE OR DESCRIPTION	MFR. CODE	CIRCUIT REF.	ITEM NO.
----------	-------------------------	-----------------------------	-----------	--------------	----------

UNLESS OTHERWISE SPECIFIED		CONTR. NO.	
DIMENSIONS ARE IN INCHES		DRAWN	R J 9-3-83
TOLERANCES ON		CHECK	
DECIMALS ± .010	ANGLES ± 0° 30'	APPR	2 S 9-11-83
FRACTIONS ± 1/32		RELEASE DATE	3-6-84 KS1

NLS NON-LINEAR SYSTEMS, INC.
DEL MAR, CALIFORNIA

SCHEMATIC, SERIAL PORTS

ROBIE

APPLICATION	QTY.
NEXT ASSY.	
FINAL ASSY.	
NEXT FINAL ASSY.	

SIZE	CODE IDENT NO.	
C	03626	81-297
SCALE	WEIGHT	SHEET 2 E

6-48

6-49

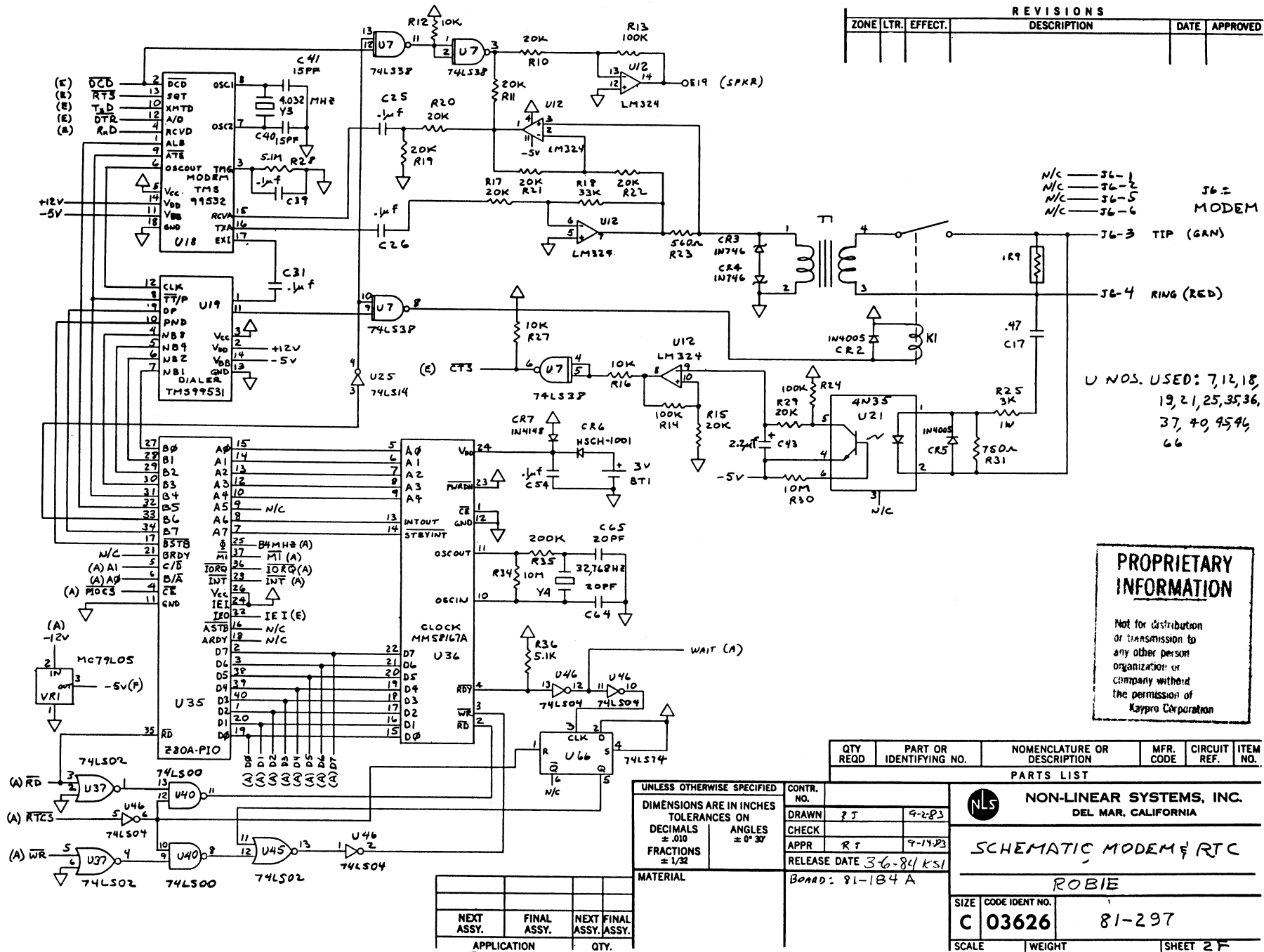

REVISIONS					
ZONE	LTR.	EFFECT.	DESCRIPTION	DATE	APPROVED

N/C — J6-1
 N/C — J6-2
 N/C — J6-5
 N/C — J6-6

J6 =
 MODEM

U NOS. USED: 7, 12, 18,
 19, 21, 25, 35, 36,
 37, 40, 45, 46,
 66

PROPRIETARY INFORMATION

Not for distribution or transmission to any other person, organization, or company without the permission of Kaypro Corporation

QTY REQD	PART OR IDENTIFYING NO.	NOMENCLATURE OR DESCRIPTION	MFR. CODE	CIRCUIT REF.	ITEM NO.
PARTS LIST					

UNLESS OTHERWISE SPECIFIED		CONTR. NO.	
DIMENSIONS ARE IN INCHES		DRAWN	J J 9-2-83
TOLERANCES ON		CHECK	
DECIMALS ±.010	ANGLES ±0°30'	APPR	R F 9-14-83
FRACTIONS ±1/32		RELEASE DATE	3-6-84 KSI
MATERIAL		BOARD:	81-184 A
NEXT ASSY.	FINAL ASSY.	NEXT FINAL ASSY.	FINAL ASSY.
APPLICATION		QTY.	

NON-LINEAR SYSTEMS, INC. DEL MAR, CALIFORNIA	
SCHEMATIC MODEM & RTC	
ROBIE	
SIZE	CODE IDENT NO.
C	03626
SCALE	WEIGHT
	81-297
SHEET 2 F	

REVISIONS

ZONE	LTR	EFFECT.	DESCRIPTION	DATE	APPROVED
	A	11-0-83	REMOVED U73 (74508)	11-18-83	KWJ
E210 SPR J9-48	B	ALL	ADDED U73 2764 pins 1227 tied to GND	1-17-84	KWJ

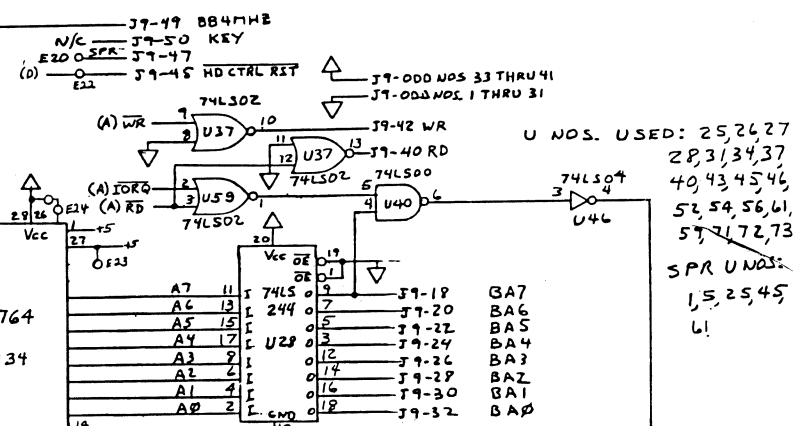
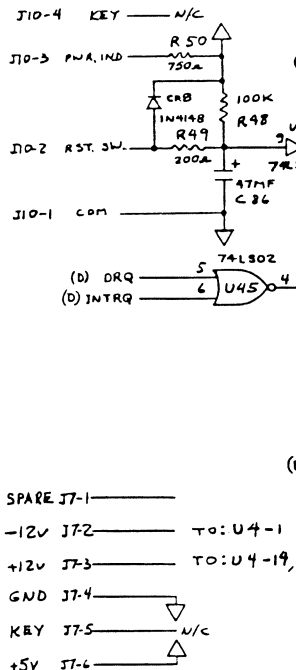
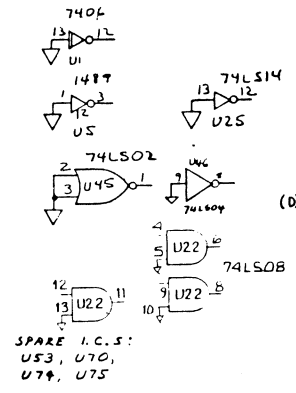
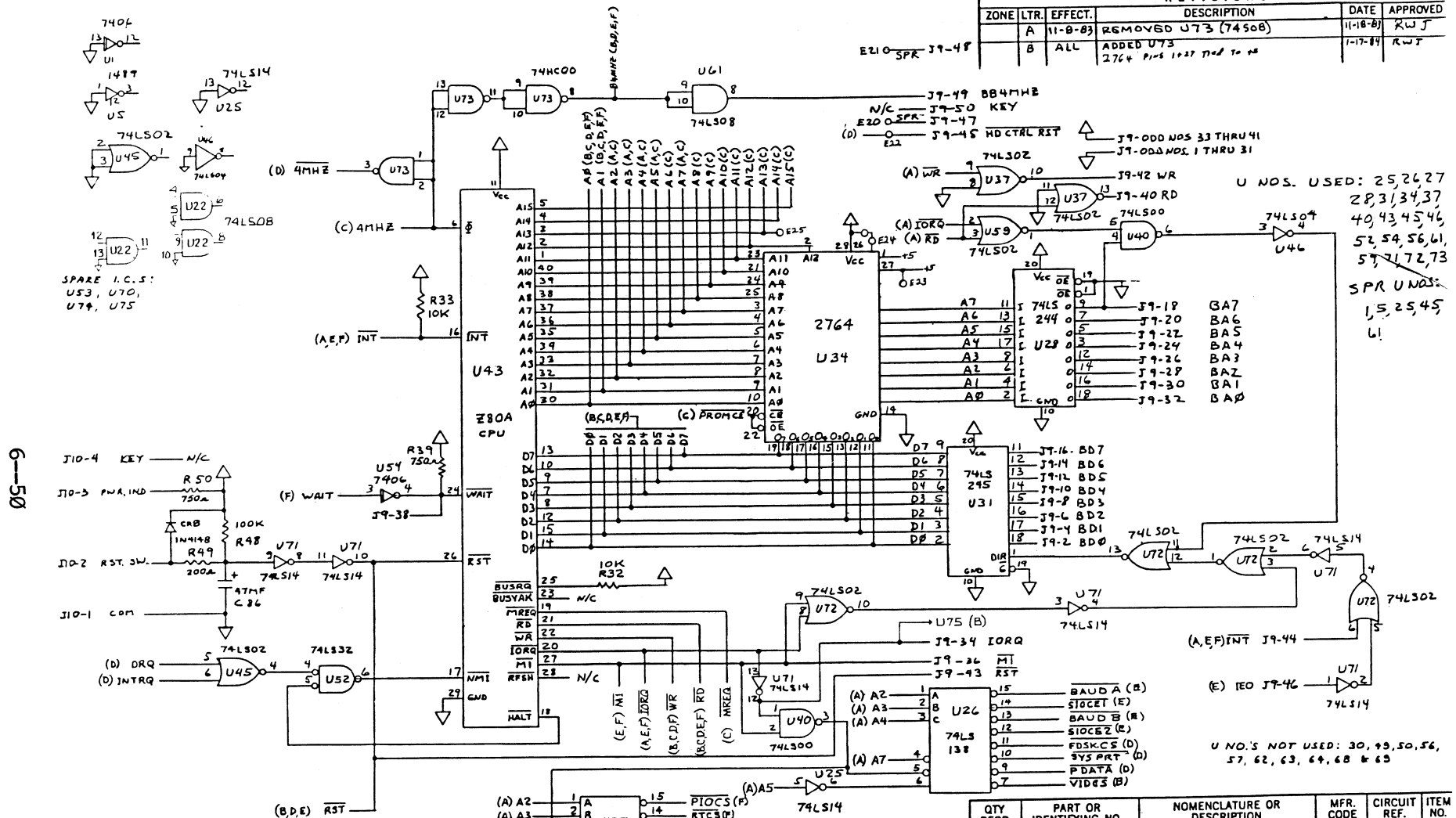

- U NOS. USED: 25, 24, 27
28, 31, 34, 37
40, 43, 45, 46
52, 54, 56, 61
57, 71, 72, 73
SPR UNOS:
1, 5, 25, 45
61

- U NOS NOT USED: 30, 39, 50, 56,
57, 62, 63, 64, 68 & 69

QTY REQD	PART OR IDENTIFYING NO.	NOMENCLATURE OR DESCRIPTION	MFR. CODE	CIRCUIT REF.	ITEM NO.
----------	-------------------------	-----------------------------	-----------	--------------	----------

NON-LINEAR SYSTEMS, INC.
DEL MAR, CALIFORNIA

SCHEMATIC, PROCESSOR

KAYPRO 2, 2x, 4, 4x, 10, 12x, RO8IE

SIZE	CODE IDENT NO.	81-185 (K2A)	81-297 (RO8IE)
C	03626	81-583 (K10)	81-29B (K4X)
		81-29S (K2X)	81-471 (K12X)

UNLESS OTHERWISE SPECIFIED	CONTR. NO.	
DIMENSIONS ARE IN INCHES	DRAWN	R J
TOLERANCES ON	CHECK	
DECIMALS ± .010	APPR	KWJ
FRACTIONS ± 1/32	RELEASE DATE	3-20-83 (KJ)

MATERIAL P.C. BOARD

81-184 REV. B
81-470 (K10, K12X ONLY)

APPLICATION	DTY
NEXT ASSY.	FINAL ASSY.
NEXT FINAL ASSY.	FINAL ASSY.

6-50

6-51

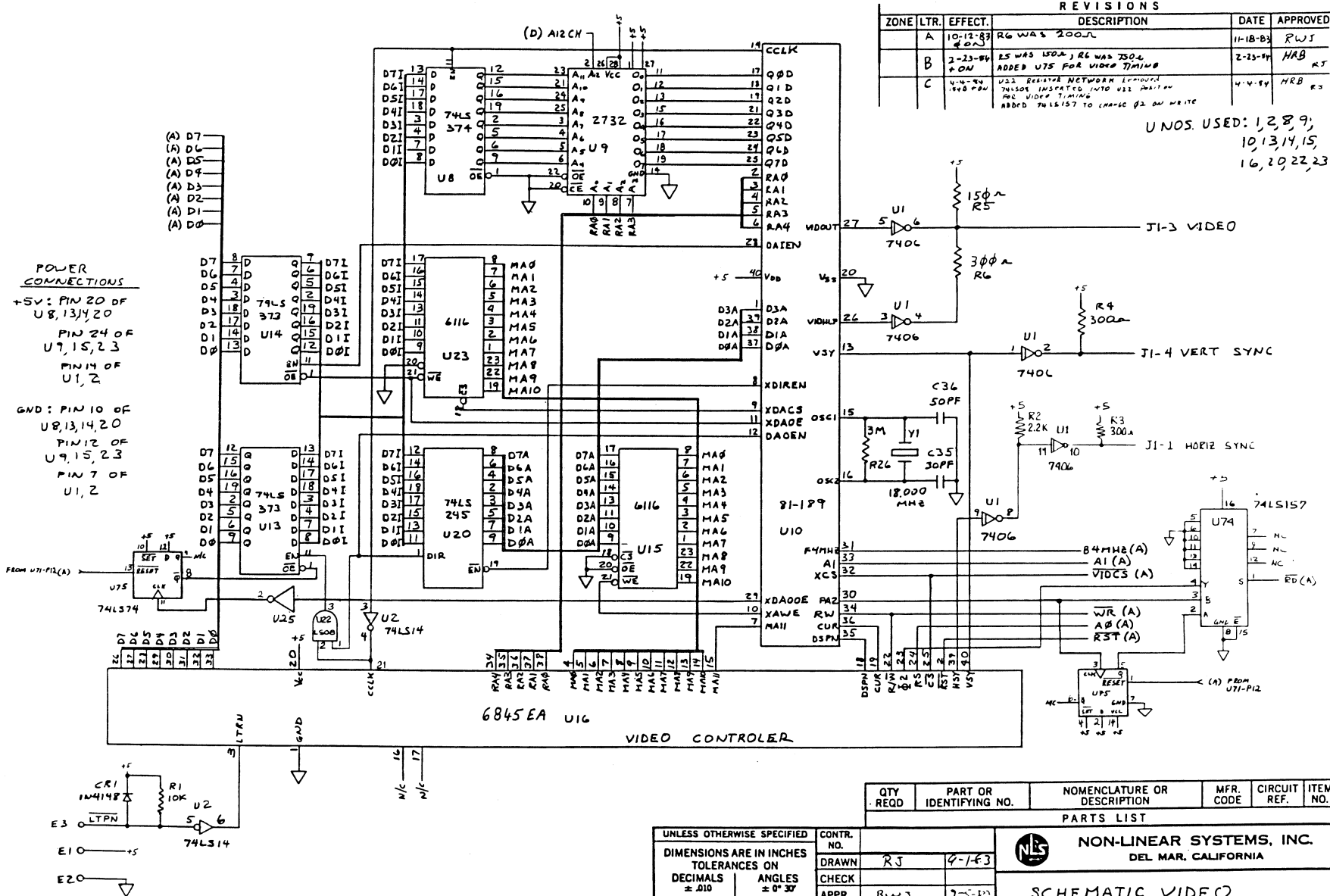

POWER CONNECTIONS
 +5V: PIN 20 OF U8, 13, 14, 20
 PIN 24 OF U7, 15, 23
 PIN 14 OF U1, 2
 GND: PIN 10 OF U8, 13, 14, 20
 PIN 12 OF U9, 15, 23
 PIN 7 OF U1, 2

ZONE	LTR.	EFFECT.	DESCRIPTION	DATE	APPROVED
A		10-12-83	R6 WAS 200Ω	11-18-83	RWJ
B		2-23-84	R5 WAS 150Ω, R6 WAS 250Ω, ADDED U75 FOR VIDEO TIMING	2-23-84	HAB
C		4-4-84	U22 RESISTOR NETWORK IN FRONT OF U20 NOT INSTALLED INTO U11 POSITION FOR VIDEO TIMING. ADDED 74LS157 TO CHANGE D2 ON WRITE	4-4-84	HRB

UNOS. USED: 1, 2, 8, 9, 10, 13, 14, 15, 16, 20, 22, 23

QTY REQD	PART OR IDENTIFYING NO.	NOMENCLATURE OR DESCRIPTION	MFR. CODE	CIRCUIT REF.	ITEM NO.
----------	-------------------------	-----------------------------	-----------	--------------	----------

UNLESS OTHERWISE SPECIFIED	
DIMENSIONS ARE IN INCHES	CONTR. NO.
TOLERANCES ON	DRAWN RJ 6-1-83
DECIMALS	CHECK
ANGLES	APPR RWJ 7-5-83
± 0.10	RELEASE DATE 9-26-83
FRACTIONS	
± 1/32	

NON-LINEAR SYSTEMS, INC.
 DEL MAR, CALIFORNIA

SCHEMATIC VIDEO

KAYPRO 2,2x,4,4x,10,12x,RODIE

SIZE	CODE IDENT NO.	81-185 (K24) 81-297 (RODIE)
C	03626	81-58 (K10) 81-298 (K4X)
		81-295 (K2X) 81-471 (K12X)

MATERIAL	PC BOARD
APPLICATION	81-104 REV B
NEXT ASSY.	OK
FINAL ASSY.	81-470 (K10, K12X ONLY)
NEXT FINAL ASSY.	
FINAL ASSY.	

6-52

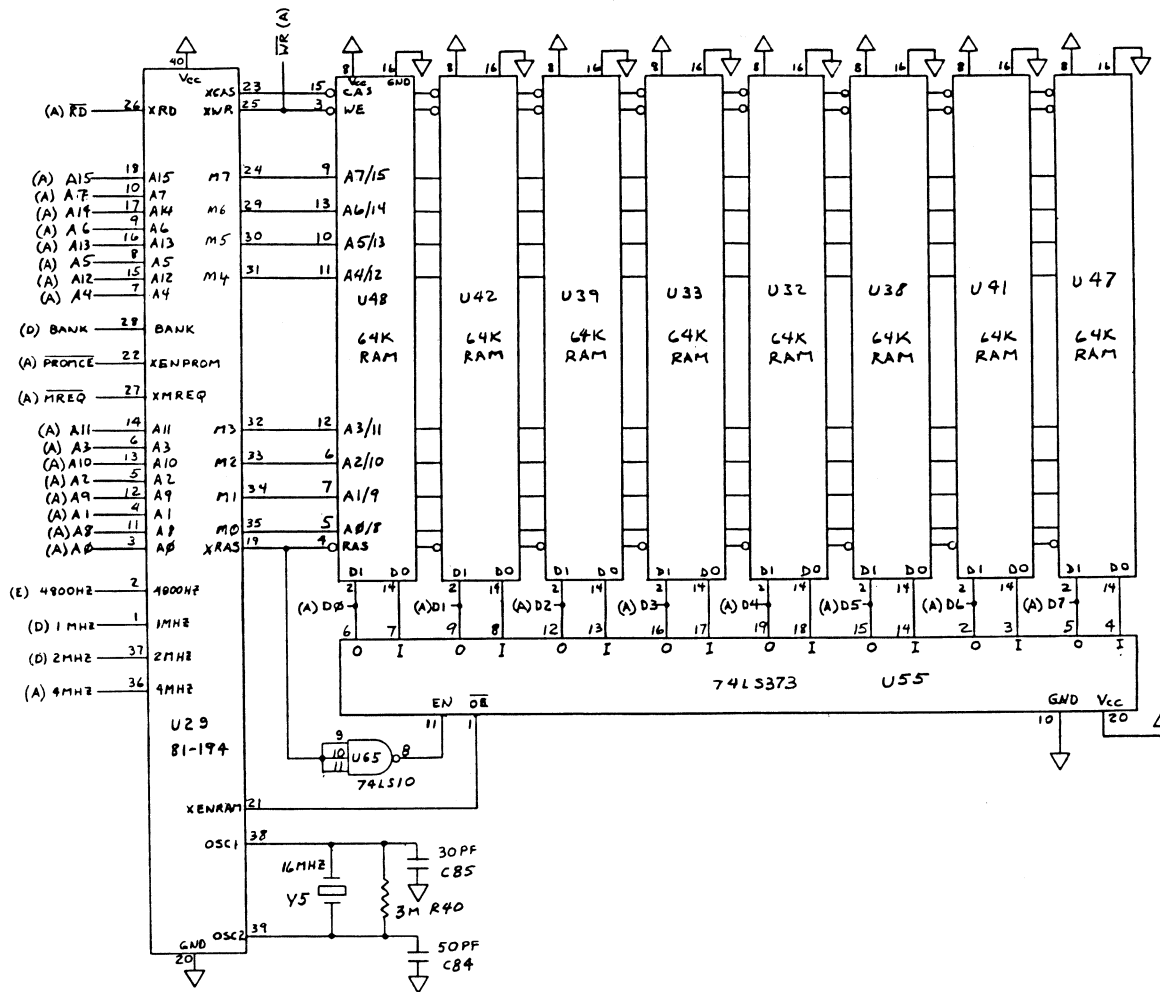

REVISIONS

ZONE	LTR.	EFFECT.	DESCRIPTION	DATE	APPROVED

UNDS USED: 29, 48, 42,
39, 33, 32, 38, 41, 47, 55,
65

QTY REQD	PART OR IDENTIFYING NO.	NOMENCLATURE OR DESCRIPTION	MFR. CODE	CIRCUIT REF.	ITEM NO.
----------	-------------------------	-----------------------------	-----------	--------------	----------

PARTS LIST

UNLESS OTHERWISE SPECIFIED		CONTR. NO.
DIMENSIONS ARE IN INCHES		DRAWN R J
TOLERANCES ON		CHECK
DECIMALS ± .010	ANGLES ± 0° 30'	APPR R J
FRACTIONS ± 1/32		RELEASE DATE 1-20-83

NLS NON-LINEAR SYSTEMS, INC.
DEL MAR, CALIFORNIA

SCHMATIC, RAM

KAYPRO 2, 2x, 4, 4x, 10, 12x, RO8IE

SIZE	CODE IDENT NO.	81-185 (K24) 81-297 (RO8IE)
C	03626	81-577 (K10) 81-298 (K4X)
		81-295 (K2X) 81-471 (K12X)

SCALE WEIGHT SHEET 2 C

NEXT ASSY.	FINAL ASSY.	NEXT FINAL ASSY.
APPLICATION		QTY.

MATERIAL P.C BOARD

81-184 REV. B

81-470 (K10, K12x ONLY)

6-53

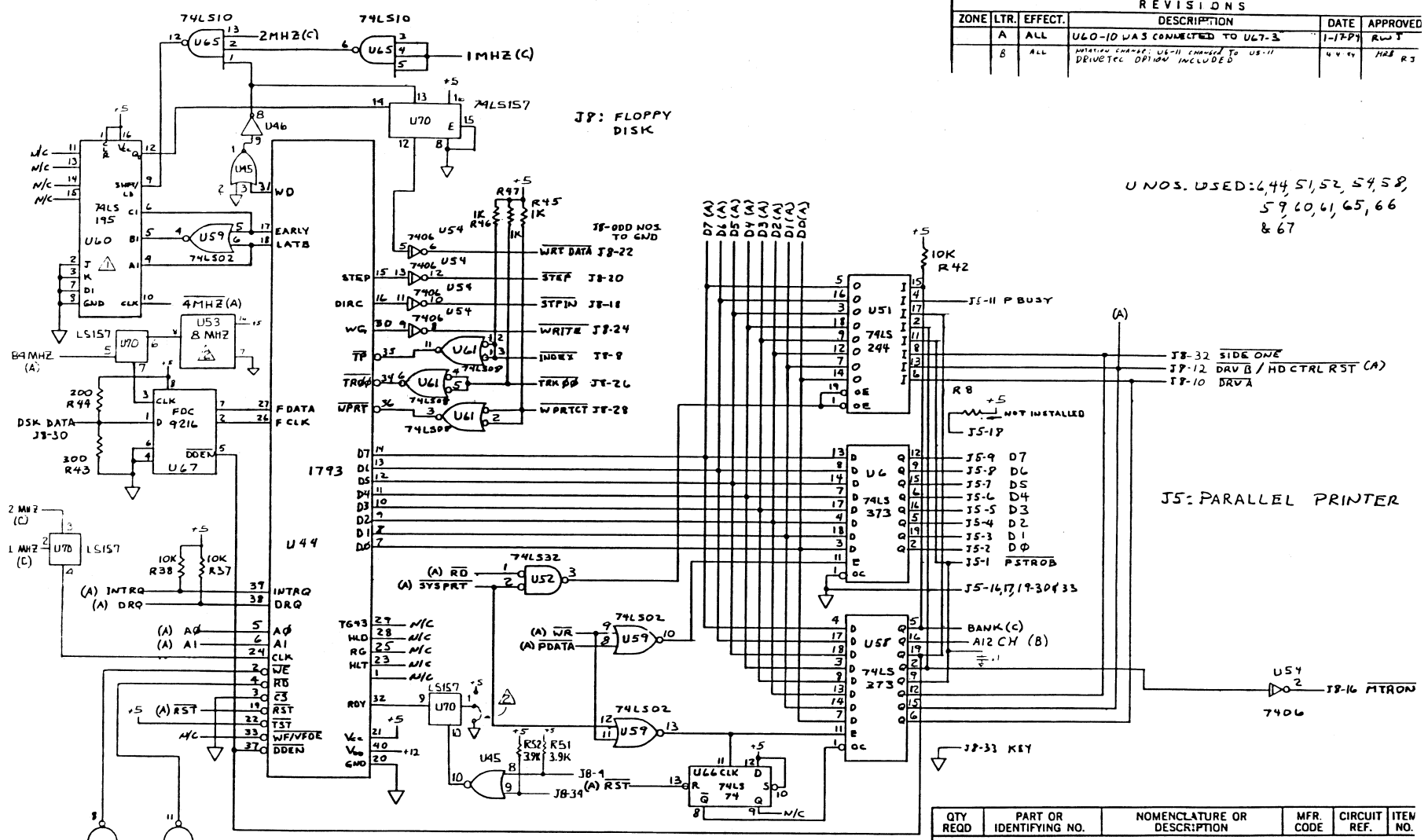

REVISIONS					
ZONE	LTR.	EFFECT.	DESCRIPTION	DATE	APPROVED
A	ALL		U60-10 WAS CONNECTED TO U67-3	1-17-73	RWJ
B	ALL		MINOR CHANGE: U5-11 CHANGED TO U5-11 DRIVETEC OPTION INCLUDED	4-4-74	HAS RJ

QTY REQD	PART OR IDENTIFYING NO.	NOMENCLATURE OR DESCRIPTION	MFR. CODE	CIRCUIT REF.	ITEM NO.
----------	-------------------------	-----------------------------	-----------	--------------	----------

UNLESS OTHERWISE SPECIFIED		CONTR. NO.
DIMENSIONS ARE IN INCHES	TOLERANCES ON DECIMALS ±.010	DRAWN RT
FRACTIONS ± 1/32	ANGLES ± 0° 30'	CHECK
		APPR RWJ
		RELEASE DATE 4-20-83

MATERIAL		PC. BOARD
NEXT ASSY.	FINAL ASSY.	81-184 REV. B
	NEXT FINAL ASSY.	OR 81-470 (K10, K12 ONLY)
APPLICATION	QTY.	

NON-LINEAR SYSTEMS, INC.
DEL MAR, CALIFORNIA

SCHEMATIC, FLOPPY CONTROL & PARALLEL PRINTER

KAYPRO 2.2x, 4.4x, 10.12x, ROBBIE

SIZE	CODE IDENT NO.	81-185 (K24) 81-297 (ROBBIE)
C	03626	81-523 (K10) 81-298 (K4X)
		81-295 (K2X) 81-471 (K12X)
SCALE	WEIGHT	SHEET 2 D

NOTES:
 △ ON 4X, 12X, ROBBIE: CUT JUMPER. ADD JUMPER TO +5V. INSTALL US3.
 △ U60 INSTALLED ON 2.2X, 4.10.

6-54

J3 PINS N/C:
4, 6, 8, 19, 21, 25

J3:
SERIAL PRINTER

PWR TO U4: +12V TO PIN 14
GND TO PIN 7
-12V TO PIN 1

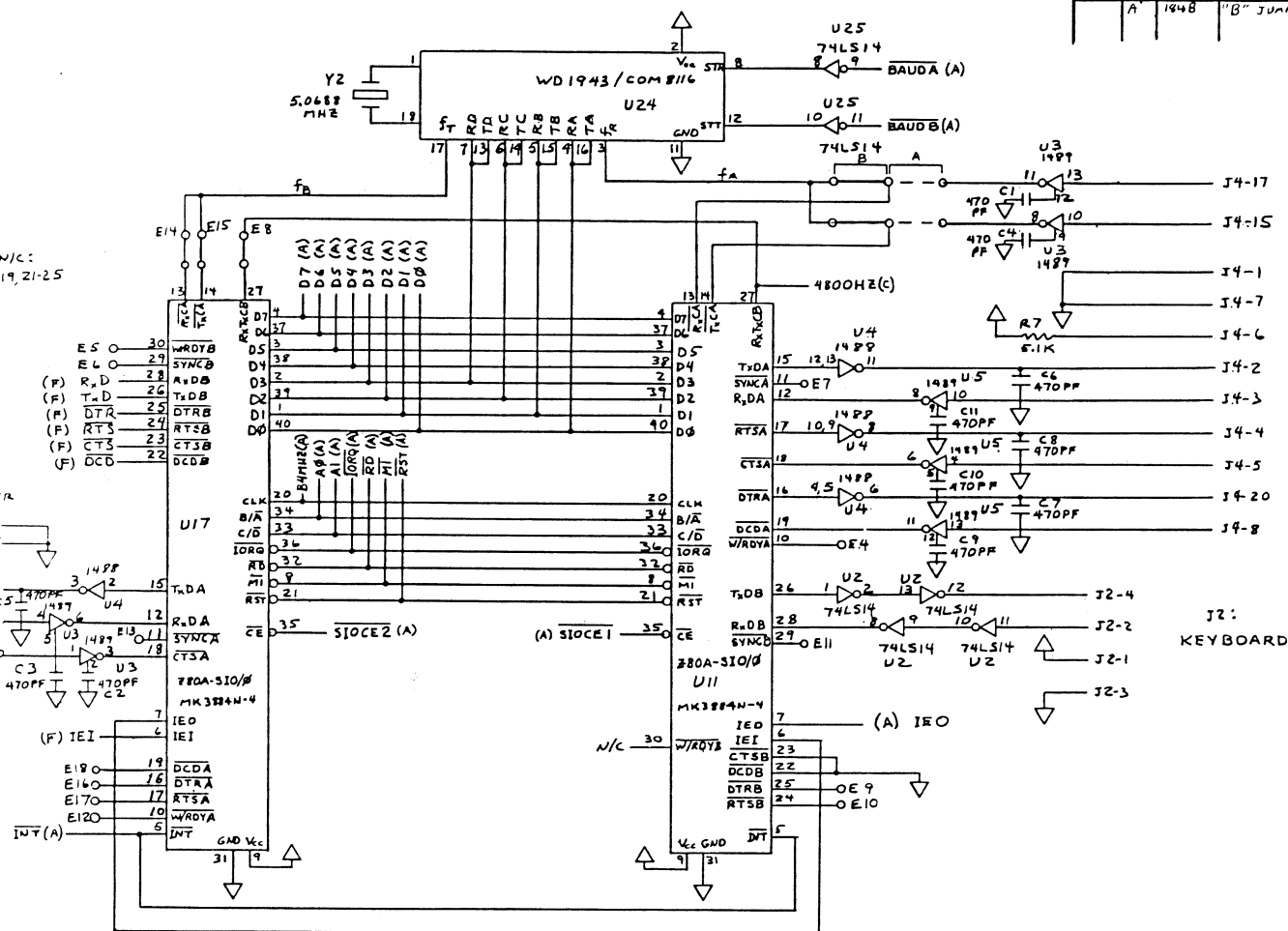

REVISIONS					
ZONE	LTR.	EFFECT.	DESCRIPTION	DATE	APPROVED
A	1948		"B" JUMPER INSTALLED IN FOIL	3-22-74	MRB NJ

U NOS. USED: 23, 45, 11
17, 24, 25

J4:
SERIAL
DATA CHANNEL

= 4 PINS N/C: 9, 14, 16, 19, 21, 25

J2:
KEYBOARD

QTY REQD	PART OR IDENTIFYING NO.	NOMENCLATURE OR DESCRIPTION	MFR. CODE	CIRCUIT REF.	ITEM NO.
----------	-------------------------	-----------------------------	-----------	--------------	----------

UNLESS OTHERWISE SPECIFIED		CONTR. NO.
DIMENSIONS ARE IN INCHES		DRAWN R J
TOLERANCES ON		9-3-77
DECIMALS ± .010	ANGLES ± 0° 30'	CHECK
FRACTIONS ± 1/32		APPR RWJ
		7-5-77
		RELEASE DATE 9-20-85 KAD

NLS NON-LINEAR SYSTEMS, INC.
DEL MAR, CALIFORNIA

SCHEMATIC, SERIAL PORTS

KAYPRO 2, 2x, 4, 4x, 10, 12x, ROBIE

SIZE	CODE IDENT NO.	81-185 (K24)	81-297 (ROBIE)
C	03626	81-583 (K10)	81-298 (K1X)
		81-295 (K2X)	81-471 (K12X)

SCALE WEIGHT SHEET 2 E

NEXT ASSY.	FINAL ASSY.	NEXT ASSY.	FINAL ASSY.	QTY.
APPLICATION				

MATERIAL	P.C. BOARD
	81-184 REV. B
	81-470 (K10, K12X ONLY)

6-55

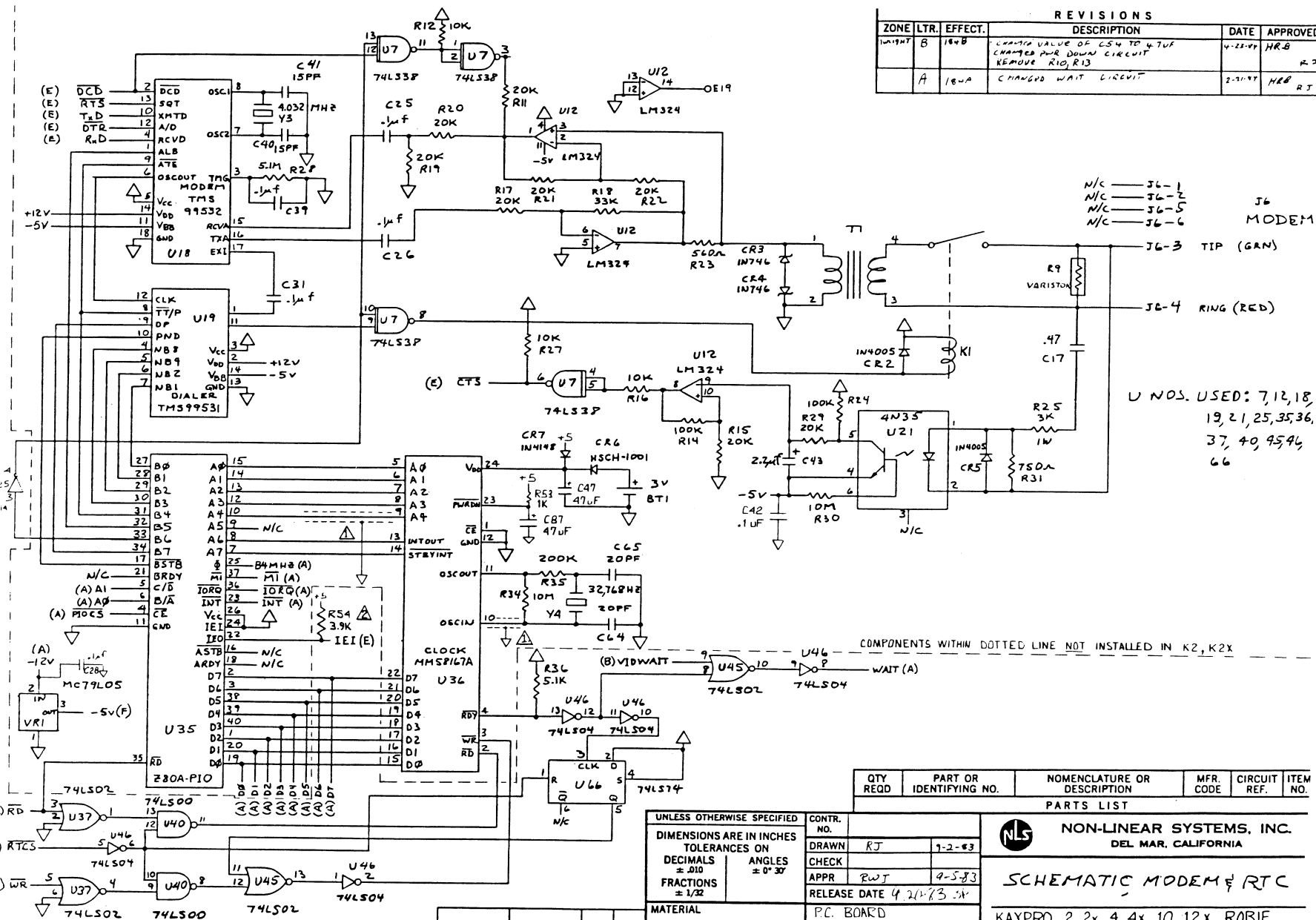

ZONE	LTR.	EFFECT.	DESCRIPTION	DATE	APPROVED
	B	18WB	CHANGE VALUE OF C54 TO 4.7UF CHANGED PWR DOWN CIRCUIT REMOVE R10,R13	4-23-83	HRB
	A	18WA	CHANGED WAIT CIRCUIT	2-21-83	HRB RT

- N/C - J6-1
- N/C - J6-2
- N/C - J6-5
- N/C - J6-6

J6 MODEM

J6-3 TIP (GRN)

J6-4 RING (RED)

U NOS. USED: 7,12,18,
19,21,25,35,36,
37,40,45,46,
66

COMPONENTS WITHIN DOTTED LINE NOT INSTALLED IN K2, K2X

QTY REQD	PART OR IDENTIFYING NO.	NOMENCLATURE OR DESCRIPTION	MFR. CODE	CIRCUIT REF.	ITEM NO.
----------	-------------------------	-----------------------------	-----------	--------------	----------

NON-LINEAR SYSTEMS, INC.
DEL MAR, CALIFORNIA



SCHEMATIC MODEM & RTC

KAYPRO 2,2x,4,4x,10,12x,ROBIE

SIZE	CODE IDENT NO.	81-185 (K2A)	81-297 (ROBIE)
C 03626		81-583 (K10)	81-298 (K4X)
		81-295 (K2X)	81-471 (K12X)

NOTES: 1. INSTALLED IN KAYPRO 2 ONLY.
SHIELDED BY 2 ADJACENT GROUNDED TRACES.

APPLICATION	QTY.
NEXT ASSY.	
FINAL ASSY.	
NEXT FINAL ASSY.	
FINAL ASSY.	

UNLESS OTHERWISE SPECIFIED
DIMENSIONS ARE IN INCHES
TOLERANCES ON DECIMALS ± .010 ANGLES ± 0° 30'
FRACTIONS ± 1/32

MATERIAL

CONTR. NO.	7-2-83
DRAWN	RJ
CHECK	
APPR	RWJ
RELEASE DATE	4-21-83

P.C. BOARD

81-184 REV B

81-470 (K10, K12X ONLY)

SCALE _____ WEIGHT _____ SHEET 2 F

REVISIONS					
ZONE	LTR	EFFECT.	DESCRIPTION	DATE	APPROVED

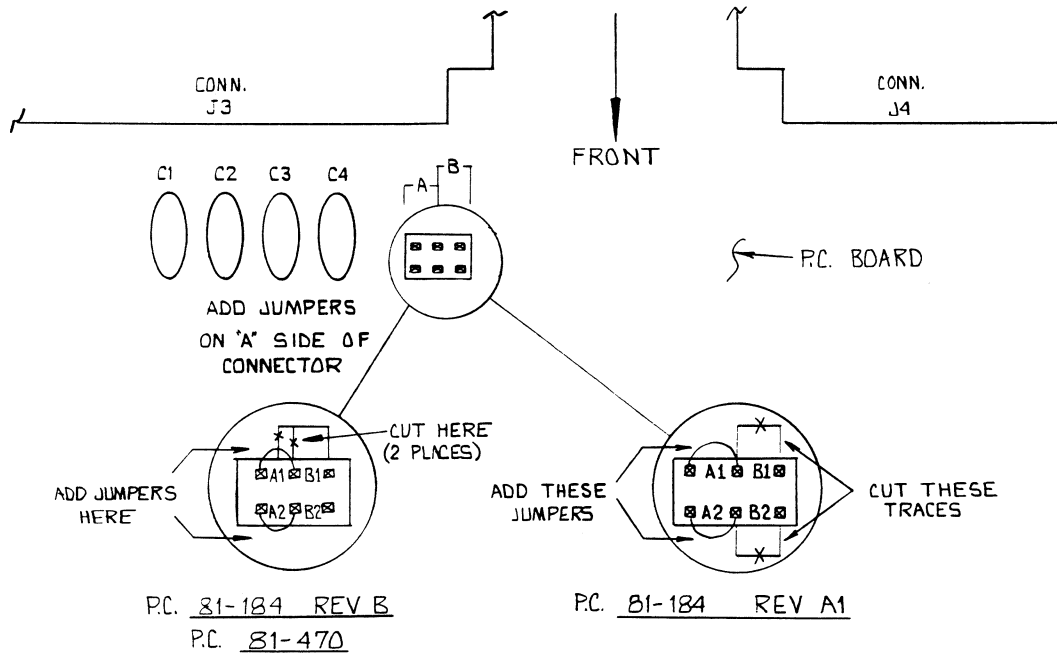

QTY REQD	PART OR IDENTIFYING NO.	NOMENCLATURE OR DESCRIPTION	MFR. CODE	CIRCUIT REF.	ITEM NO.
----------	-------------------------	-----------------------------	-----------	--------------	----------

PARTS LIST

UNLESS OTHERWISE SPECIFIED		CONTR. NO.		NON-LINEAR SYSTEMS, INC. DEL MAR, CALIFORNIA
DIMENSIONS ARE IN INCHES		DRAWN	K.BILIN&KI 5-29-84	
TOLERANCES ON		CHECK	T.SOULE 5-29-84	
DECIMALS ± .010		APPR	RWJ 5-30-84	
ANGLES ± 0° 30'		RELEASE DATE	5-30-84	USER OPTION: SYNCHRONOUS DATA MOD. (KAYPRO 2,2X,4,4X,10,12X,ROBIE)
FRACTIONS ± 1/32		MATERIAL		SIZE B CODE IDENT NO. 03626 ASSY: 81-185(K2,4) 81-277(RDBIE) 81-533(K10) 81-298(K4X) 81-295(K2X) 81-471(K12X)
APPLICATION		QTY.		SCALE — WEIGHT — SHEET 2 G

NEXT ASSY.	FINAL ASSY.	NEXT ASSY.	FINAL ASSY.

6.7 MAINBOARD REMOVAL

1. Turn off the machine and disconnect the AC power (5.1).
2. Remove the chassis hood (5.1).
3. Remove the two screws from the front of the mainboard that attach the mainboard and the two plastic standoffs.
4. Remove the screws from the rear, top of the chassis that secure the mainboard. The KAYPRO 2/83 and 4/83 each have four Phillips-head screws and two hex-head screws. The KAYPRO 10, 2/84 and 4/84 each have three Phillips-head screws and four hex-head screws.
5. Remove the power, reset, and video plugs. On the KAYPRO 2/83 and 4/83 these are J1, J5, and J7. On the KAYPRO 10, 2/84 and 4/84 these are J1, J7, and J10.
6. Remove the ribbon cable(s). On the KAYPRO 2/83 and 4/83 this is J6. On the KAYPRO 10 they are J8 and J9. On the KAYPRO 2/84 and 4/84 this is J8.
7. Remove the mainboard.

MAINBOARD INSTALLATION

1. Set the mainboard on the plastic standoffs, insert the screws, but do not tighten them yet.
2. Align the ports and the keyboard jack with the openings on the rear, top of the chassis.
3. Insert the screws through rear of chassis into mounting holes. Do not tighten yet.
4. The KAYPRO 2/83 and 4/83 each have four Phillips-head and two hex-head screws. The KAYPRO 10, 2/84 and 4/84 each have three Phillips-head and four hex-head screws.
5. Tighten the screws on the rear of the chassis and the screws that go into the plastic standoffs.
6. Replace the power, reset, and video plugs.
7. Replace the ribbon cable(s).

7.0 CRT ASSEMBLIES

7.1 HARDWARE DESCRIPTIONS AND ADJUSTMENTS

Figure 7.1
Dotronix video board

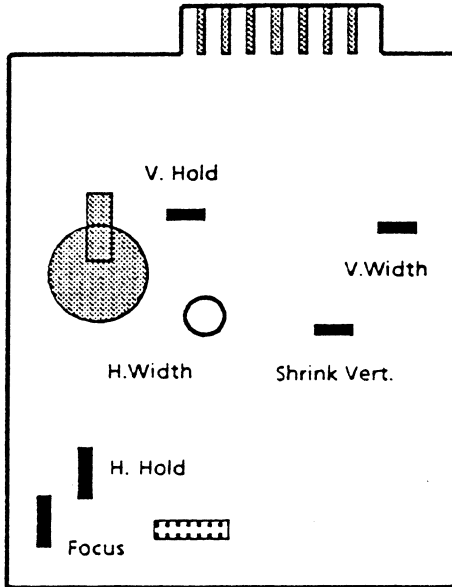
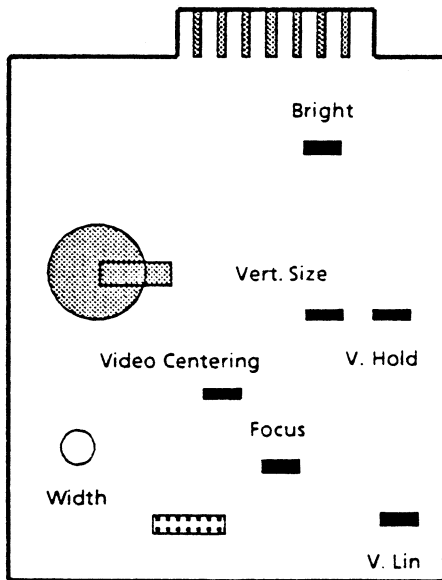

Figure 7.2
Elston video board



VIDEO ADJUSTMENTS

At the current time Kaypro is using CRT assemblies produced by Dotronix, Elston, Micrex and Toshiba. The adjustment pots are positioned in different locations on the boards and can be located by using figures 7.1 through 7.4. These pots are factory aligned and normally need no adjustment. The purpose of these adjustments is to obtain the correct size, centering, and brightness of the display.

Use only non-metallic tools when making these adjustments.

Before any adjustments are made on the video board, the ALIGN diagnostic should be invoked. This will fill the screen with H's and aid in adjustment.

HORIZONTAL CENTERING

Check to see that the pattern is centered on the screen. Adjust the horizontal hold pot until the display is correctly centered. On the Elston video board, adjust the video centering pot.

VERTICAL SIZE AND LINEARITY

The following two procedures are to be performed alternately until correct display is obtained.

Adjust the vertical size pot to obtain pattern height of approximately 4-7/8 inches.

Adjust vertical linearity pot until all characters are the same vertical size, top to bottom.

HORIZONTAL WIDTH

Adjust the horizontal width pot to obtain a display width of approximately 7 inches.

HORIZONTAL HOLD (KAYPRO 2/83 and 4/83 with Dotronix only)

Figure 7.3
Toshiba video board

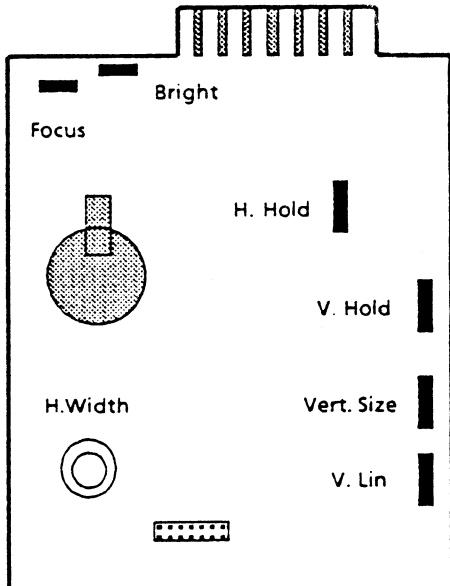

These procedures should be performed to adjust horizontal hold.

Attach one end of a test jumper to TP2 (test point 2). Attach the other end of the jumper to the heat sink at Q3.

Adjust R43 (horizontal hold pot) until the display either stops scrolling or almost stops. (sometimes they don't stop scrolling completely)

Disconnect the test jumper.

Adjust the horizontal deflection rings as needed.

FOCUS

Adjust the focus pot until the edges and center of the display image are in focus.

BRIGHTNESS

To prolong the life of the CRT, the maximum brightness obtainable should not be excessive. If the brightness is excessive, adjust the brightness pot. If the raster lines are visible, the brightness pot should be adjusted until they disappear.

Figure 7.4
Micrex video board

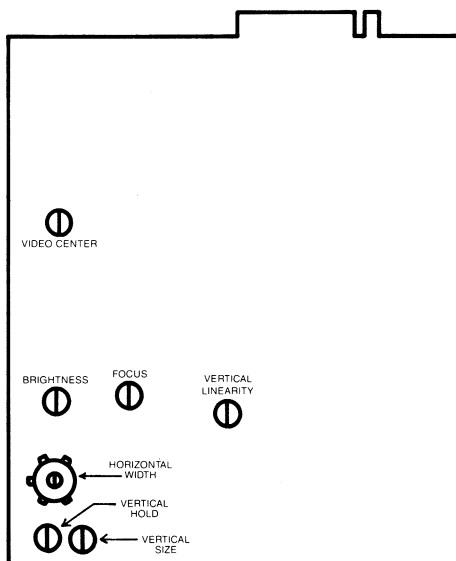

ALIGNING CRT YOKE

*** CAUTION ***

HIGH VOLTAGE IS PRESENT AT THIS POINT

Figure 7.5
Yoke alignment

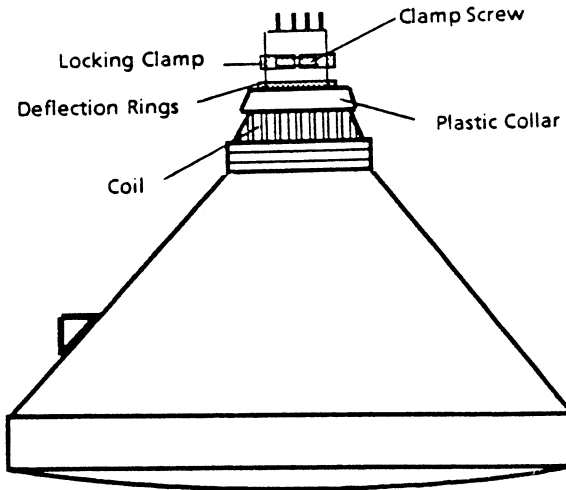

Loosen the screw on the locking clamp (figure 7.5).

Grasp the white collar on the rear of the coil.

Turn the collar in the direction required to square the display.

Turn the collar slightly past the alignment point, as it will turn back slightly when released.

Tighten the locking screw.

THIS PAGE INTENTIONALLY LEFT BLANK

7.2 PERFECT VIDEO ALIGNMENT EXAMPLE

Below is an example of perfect video alignment with a capital E positioned along the borders. You can copy this diagram onto a piece of clear, stiff plastic to use as a template over the screen.

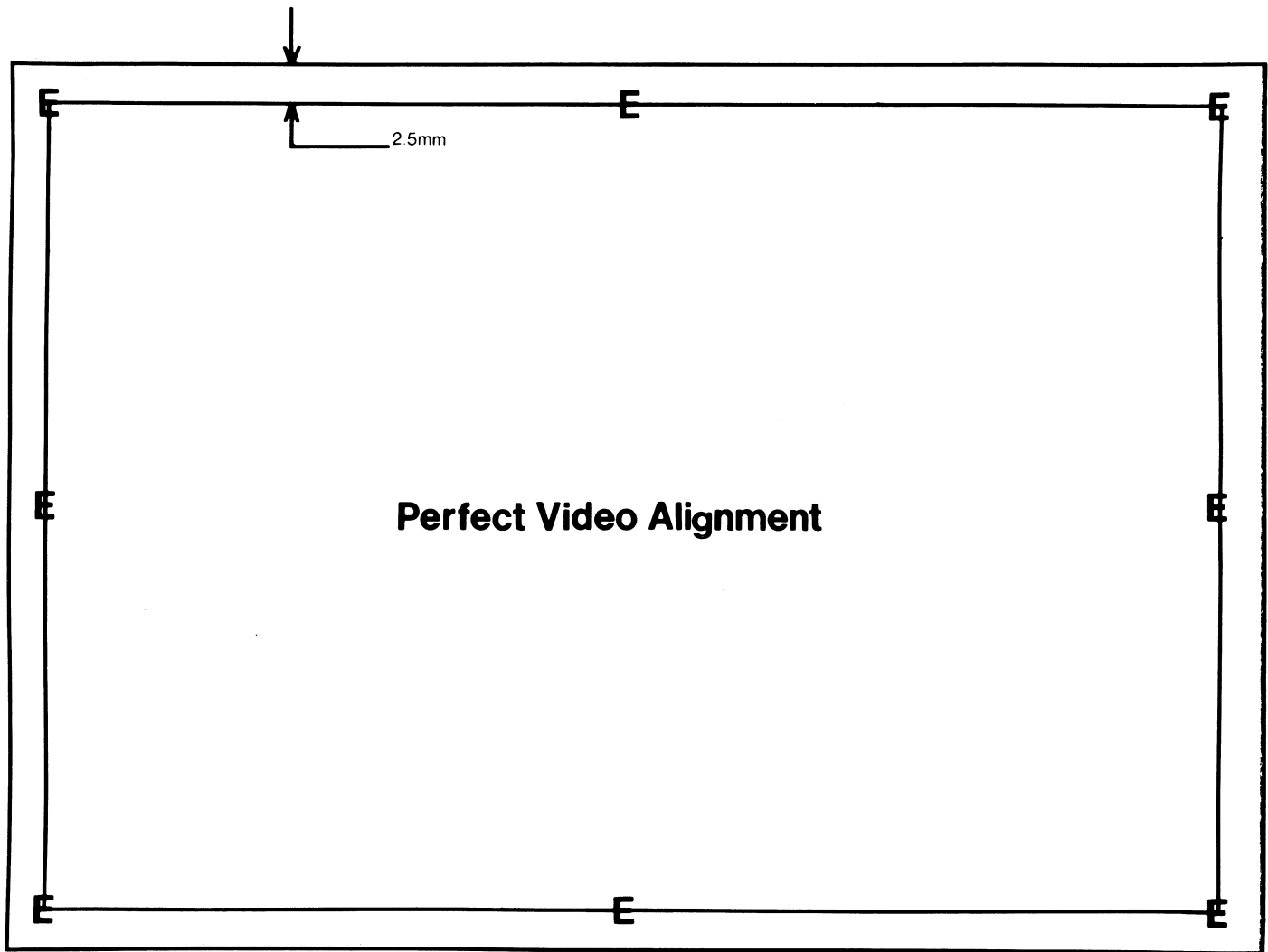

7.3 VIDEO SIGNALS, ON KAYPRO MAINBOARD

Below is a list of the video signals on connector J1 of the mainboard and the voltages on the video board. Repeated removal and installation of the video board connector will loosen the connection and produce poor contact. Malfunctions due to a loose connector can be very difficult to trace.

Video comes from the main board as separate signals, not as a composite like a TV signal.

A simple check for 12V on the video board is to turn the BRIGHTNESS pot up, then turn the rear panel brightness control down. If 12V is present on the board, you should be able to see the raster lines on the screen.

Video signals on main board at J1

- Pin 1 - Horizontal Sync.
- Pin 2 - Key
- Pin 3 - Video
- Pin 4 - Vertical Sync.

Voltages on Video Board

- Pin 1 → 0v
- Pin 6 → 0v
- Pin 7 → 12v
- Pin 8 → 0v
- Pin 9 → 4v approx. (this voltage controls brightness)
- Pin 10 → 0v

7.4 CRT ASSEMBLY REMOVAL, (EXCEPT ROBE)

1. Turn off the machine and disconnect the AC power (5.1).
2. Remove the chassis hood (5.1).
3. Remove the mainboard (6.7).
4. Remove the four screws that connect the video PCB and the bottom of the chassis. This should be done from the outside, bottom of the chassis, not from inside the machine.
5. Remove the video connector from the back of the video PCB.
6. Remove the four screws that connect the CRT to the front of the machine chassis.
7. Remove the CRT assembly from the chassis.
8. Remove the four plastic standoffs from the CRT PCB. These can be used on the new CRT PCB.

CRT ASSEMBLY INSTALLATION

*** Note: Before starting with CRT installation, check to see if the small plastic standoffs are attached to the bottom of the CRT PCB. If they are not attached, use the ones from the old board.

1. Lower the CRT assembly into the chassis.
2. Position the CRT so that the top mounting holes are aligned with the two metal standoffs on the chassis.
3. Insert screws through the top two mounting holes on the CRT and into the standoffs, but do not tighten.
4. Insert screws through the bottom two mounting holes on the CRT and into the standoffs. Tighten these two screws and the top two screws.
5. Hold the CRT PCB in place and tilt the machine up so that it is sitting on the cord wraps.
6. Align the plastic standoffs on the PCB with the holes in the bottom of the chassis.
7. Insert the four screws and tighten securely.
8. Replace the video connector on the back of the video PCB.

8.0 POWER SUPPLIES

8.1 INTRODUCTION

Kaypro is using three different brands of power supplies at the present time. These are Astec, Boschert, and Cal D.C. These three power supplies are interchangeable with any of the Kaypro computers, if the power supply being changed is a new one from the factory.

*** EXCEPTION ***

If a power supply is removed from a 2/83 or a 4/83, and it's going to be used in another computer, it MUST be used in a 2/83 or 4/83. The power supplies used in 2/83 and 4/83 computers are not interchangeable with other Kaypro computers.

There are no authorized dealer repairs that can be made on any of the power supplies. The ONLY authorized dealer service to power supplies is 220V configuration. Each brand of power supply can be configured for 220V operation.

8.2 DESCRIPTION AND 220V CONFIGURATION INSTRUCTIONS

Two fuses are associated with each of the power supplies. One fuse (2 amp) is mounted on the rear of the chassis and accessible from outside the computer. The other fuse (2.5 amp) is mounted directly on the power supply board.

Disconnect AC power from the computer whenever replacing fuses. Be especially careful when replacing the fuse on the power supply board. Use of a fuse replacement tool is recommended due to the difficulty of reaching this component.

220V CONFIGURATION

Astec Power Supply

Identified by a beige board with a white label on the right of the component side. The label will have the name ASTEC, followed by a model number, and the output voltages.

Locate the white shorting block labelled TB2. If the board is configured for 110V, a pin will be visible on the right of the shorting block.

Remove the shorting block and shift it to the right so that it covers the pin. A different pin should now be exposed on the left of the shorting block. The power supply is now configured for 220V use.

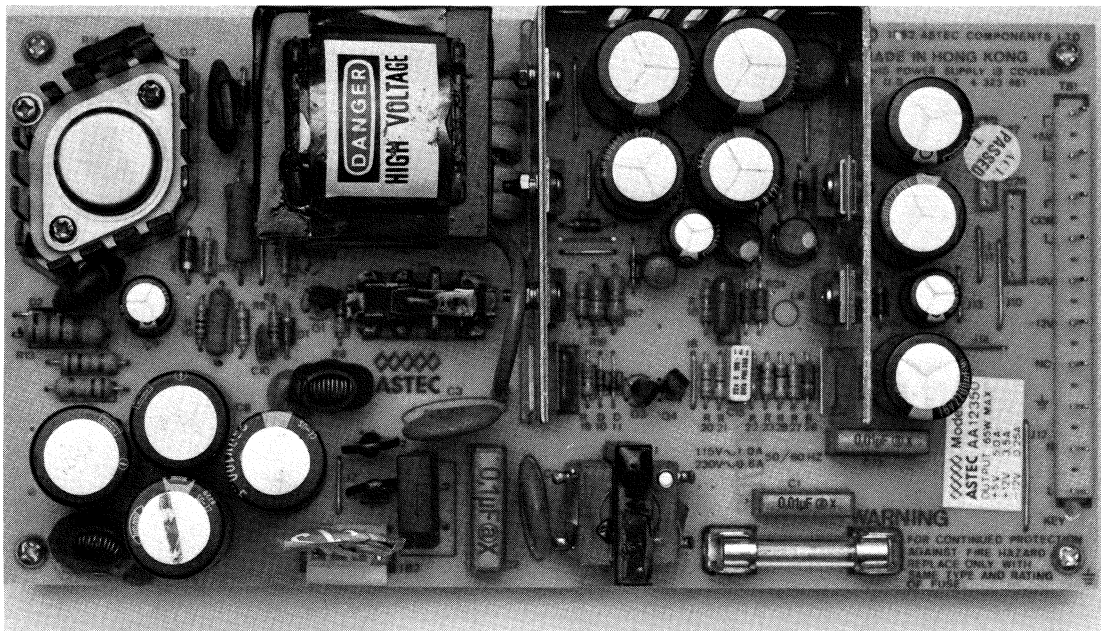

220V CONFIGURATION

Boschert Power Supply

Identified by the word "Boschert" on the component side of the board at lower right and above the fuse and capacitor C2.

Locate a six-inch wire that is soldered to point JP1. If the board is configured for 110V, the other end of the wire is attached to point E1 (labelled 110V).

Unplug the wire from point E1 and plug it into point E2 (labelled 220V). Point E2 is to the left of point E1. The power supply is now configured for 220V use.

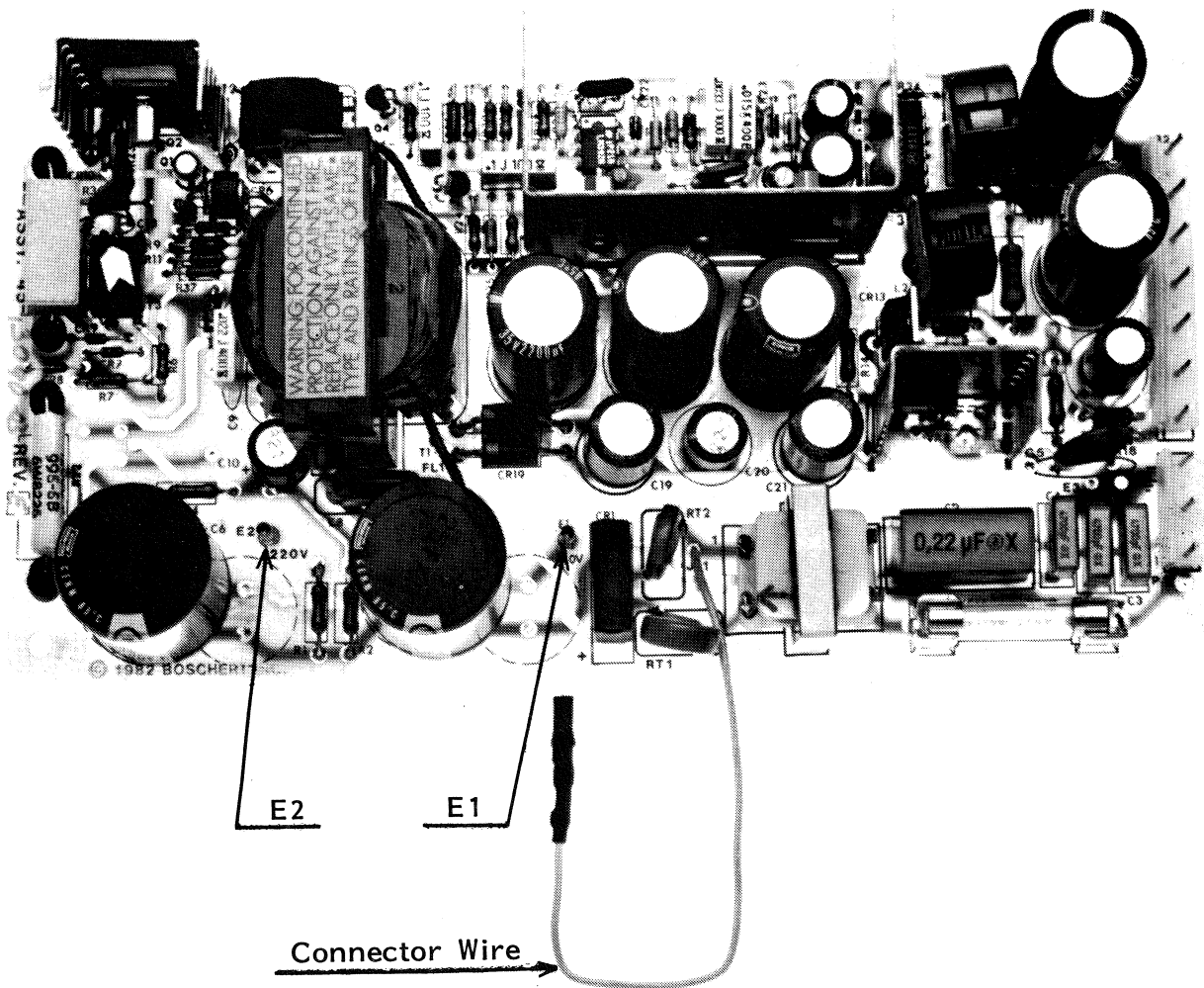

220V CONFIGURATION

Cal D.C. Power Supply

Identified by a bright blue circuit board. A white sticker with "California DC", model, and serial number is located on solder side of board.

Locate a jumper block labelled 115VAC and 230VAC. With the jumper in the 115VAC position the board is configured for 110V.

Remove the jumper from the socket labelled 115VAC and position it in the socket labelled 230VAC. The power supply is now configured for 220V use.

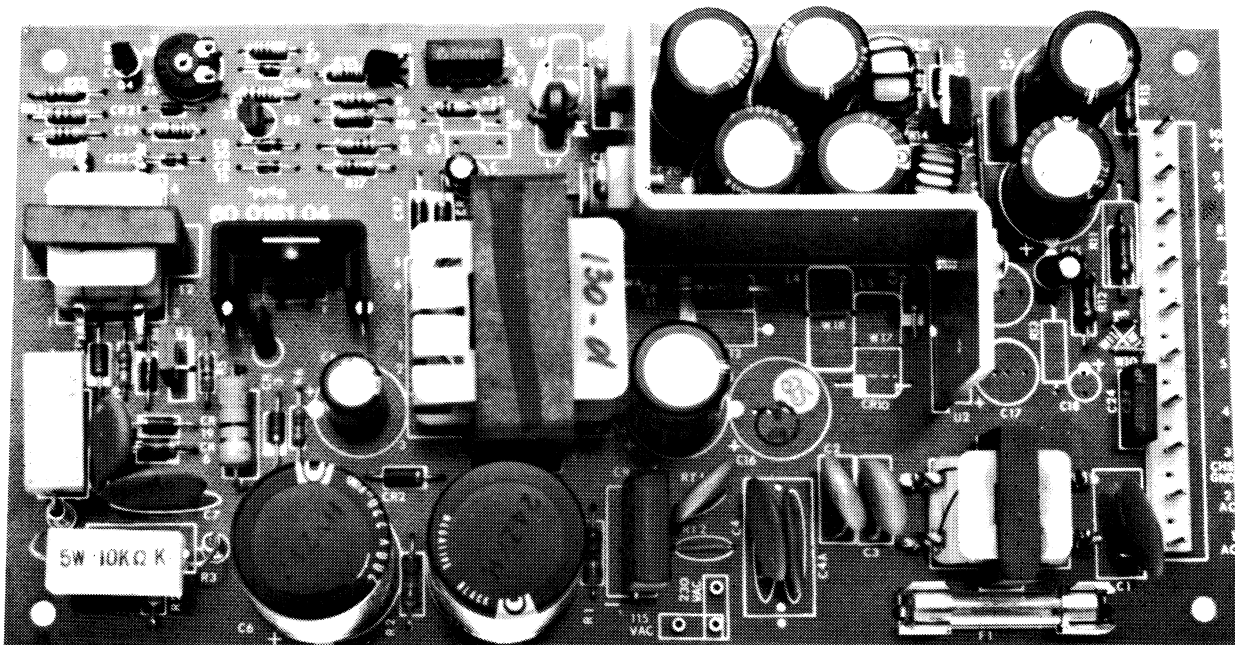

Jumper Sockets

8.3 POWER SUPPLY REMOVAL

1. Turn off the machine and disconnect the AC power (5.1).
2. Remove the chassis hood (5.1).
3. Remove the mainboard (6.7).
4. Remove the four screws that connect the power supply and the back of the chassis. These are easier to remove from outside the back of the chassis than from inside the machine.
5. Remove the power plug from the power supply.
6. Remove the tie wraps from the plastic standoffs.
7. Remove the power supply.

POWER SUPPLY INSTALLATION

1. Position the power supply inside the chassis so that the four plastic standoffs are aligned with the four mounting holes in the chassis. Be certain that the power connector is on the side nearest the drives.
2. Place the tie wraps on the plastic standoffs.
3. Insert four screws through the rear of the chassis and into the plastic standoffs of the power supply.
4. Tighten the screws securely.
5. Replace the power connector.
6. Replace the mainboard (6.7).
7. Replace the chassis hood (5.1).

9.0 DISKETTE DRIVES

9.1 INTRODUCTION

All diskette drive types (except the high-density drives in the ROBIE and 4X) are functionally interchangeable between manufacturers.

Because of the number of manufacturers from which Kaypro gets its diskette drives, no attempt is made in this manual to show alignment procedures for diskette drives. To perform drive alignments you will need a drive manual for the particular model, a Dysan Alignment Diskette (Dysan's part number: 224/2A), the knowledge and an oscilloscope. Drive manuals are available through the Hardware Technical Support Department for a nominal fee.

However, since the company recognizes the fact that many customers want a KAYPRO computer in which both drives have the same outward appearance, we provide a guide for determining models of diskette drives from the placement of the LED and the drive door closure.

This section also contains diagrams and instructions on jumpering the various models of diskette drives to be used as either A or B (or, in the case of the KAYPRO 10, C) drive.

DISK DRIVE CLEANING

Generally speaking the majority of people clean disk drives too often. Unless the environment is especially dusty or dirty, under commercial use there is no reason to clean the drives more than twice a year.

Use care in selecting a cleaning kit. Many of the drive head cleaning kits on the market are very abrasive. Cleaning is done by the liquid solution, not by mechanical scrubbing.

*****NOTE***** The manufacturer (Drivetec) of the high-density drives in the ROBIE, and 4X recommends only four brands of head-cleaning kits for their drives. The letter from Drivetec states:

"THE FOLLOWING CLEANING DISKS HAVE BEEN EVALUATED
AND ARE RECOMMENDED FOR USAGE ON THE DRIVETEC DISK
DRIVE WHEN HEAD CLEANING IS DEEMED NECESSARY:

- 1) SCOTCH #7440
- 2) HEAD COMPUTER PRODUCTS 5 1/4 CLEANING DISK
- 3) PERFECT DATA 5 1/4 CLEANING DISK
- 4) FLOPPICLENE 5 1/4 CLEANING DISK"

Refer to the symptom-fix guide for troubleshooting hints relative to the floppy drives, the Winchester hard disk, and the Drivetec (high-density) drives.

9.2 WHICH BRAND OF DRIVE IS IT?

The following figures represent the face plates of the different brands of half-height floppy drives that are used in Kaypro computers. The drive door closure and the LED position can be used to reference the drive.

Fig. 9.1, TANDON Half-Height

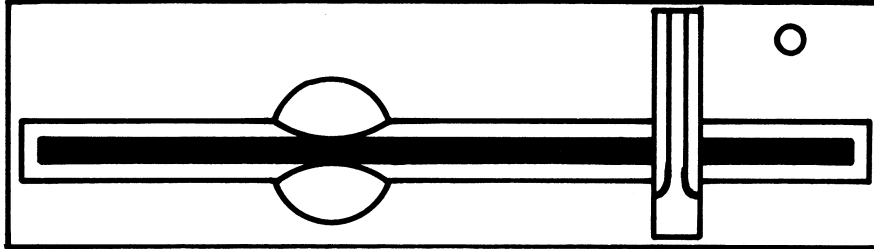

Fig. 9.2, EPSON

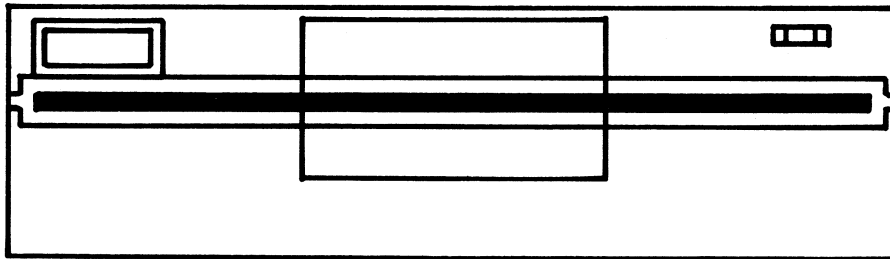

Fig. 9.3, SHUGART

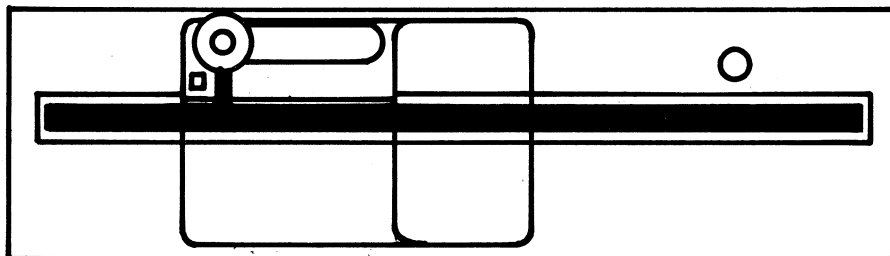

Fig. 9.4, TOKYO ELECTRIC

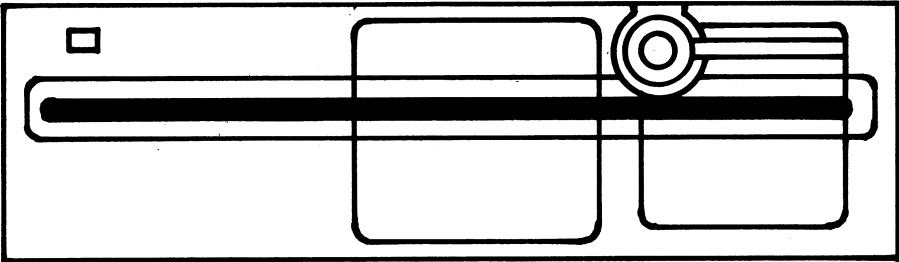

Fig. 9.5, TOSHIBA

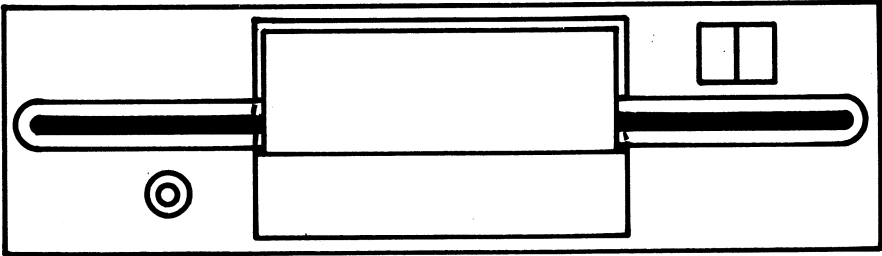

Fig. 9.6, HI-TECH

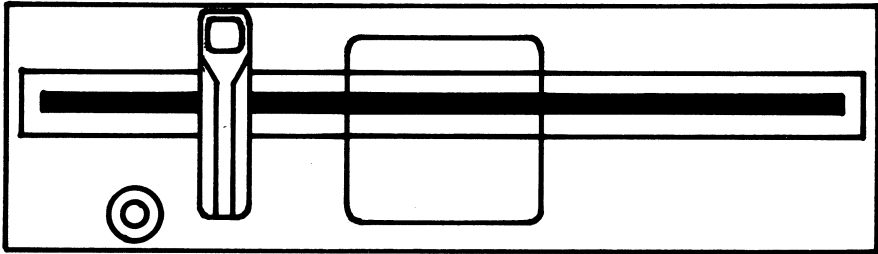

Fig. 9.7, DRIVETEC

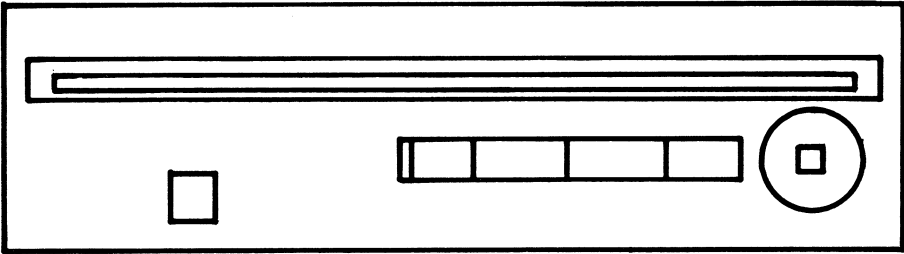
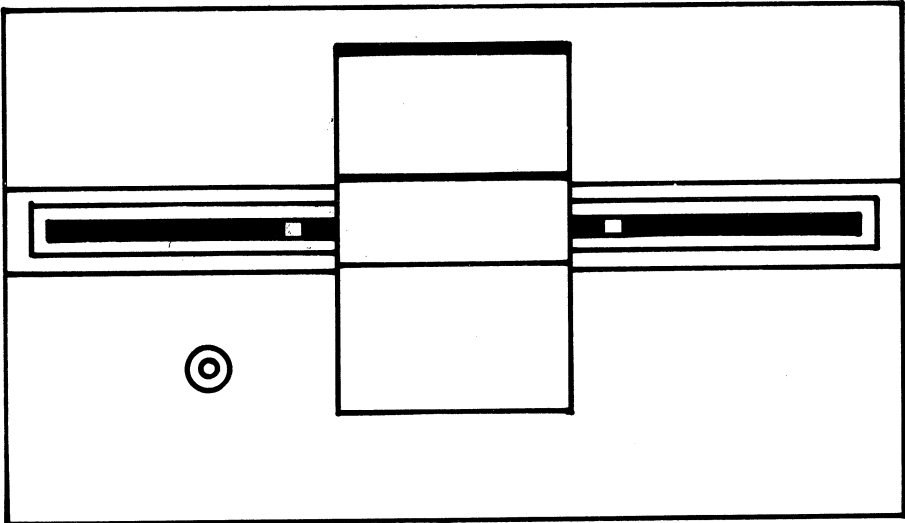

Fig. 9.8, TANDON Full-Height



9.3 JUMPERING DIAGRAMS

Figure 9.8
Tandon diskette drive

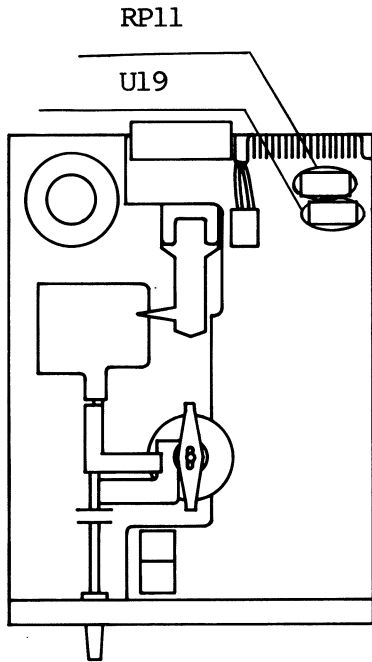
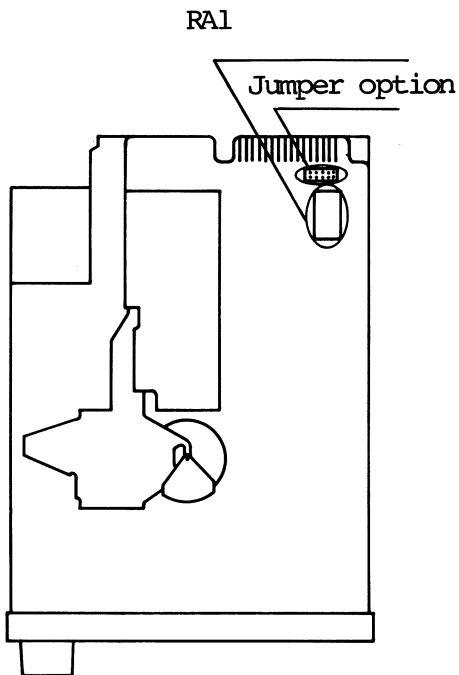

Figure 9.9
Epson diskette drive



TANDON

Used only on KAYPRO 10, Pins 2 and 15 on U19 are jumpered and a 470-ohm terminating resistor pack is inserted in RP11.

EPSON

Next to the connector for the data cable is a black plug with ten pins. These pins are jumpered to change the configuration of the drive. They are MX, 0, 1, 2, 3.

KAYPRO 10: The two pins in the "0" position should be jumpered and a 470-ohm terminating resistor inserted in RA1.

A DRIVE: Jumper the two pins in the "0" position. No terminating resistor is needed.

B DRIVE: Jumper the two pins in the "1" position. Insert a 470-ohm terminating resistor into RA1.

Figure 9.10
Shugart diskette drive

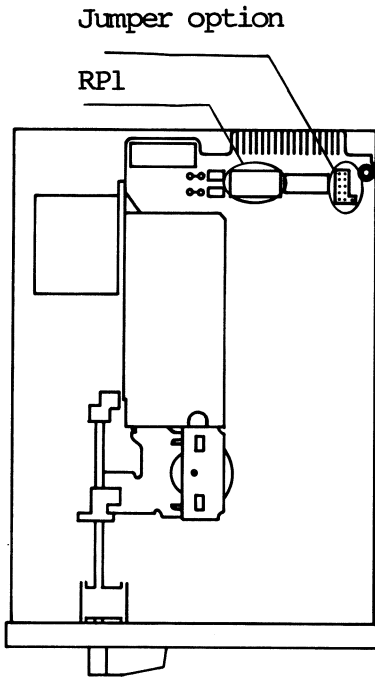

SHUGART

Next to the connector for the data cable is a blue plug with eleven pins. These pins are 1, 2, 3, 4, MX.

KAYPRO 10: Jumper the two pins in the "1" position. In the "MX" position, there are three pins. Jumper the one in the center and the one on the left of it. Insert a 470-ohm terminating resistor into RPl.

A DRIVE: Jumper the two pins in the "1" position. In the "MX" position, jumper the pin in the center and the pin on the left of it. No terminating resistor is necessary.

B DRIVE: Jumper the two pins in the "2" position. In the "MX" position, jumper the pin in the center and the pin on the left of it. Insert a 470-ohm terminating resistor into RPl.

Figure 9.11
Tokyo Electric
diskette drive

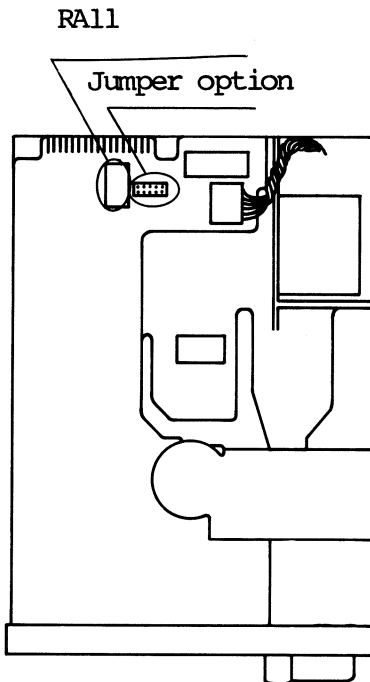

TOKYO ELECTRIC

Next to the connector for the data cable is a blue plug with ten pins. These pins are DS0, DS1, DS2, DS3, MX.

KAYPRO 10: Jumper the two pins in the "DS0" position. Insert a 470-ohm terminating resistor into RAll.

A DRIVE: Jumper the two pins in the "DS0" position. No terminating resistor is necessary.

B DRIVE: Jumper the two pins in the "DS1" position. Insert a 470-ohm terminating resistor into RAll.

Figure 9.12
Toshiba diskette drive

Jumper option

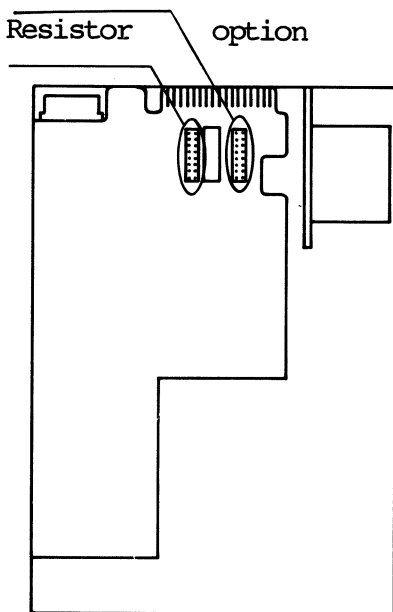

TOSHIBA

Next to the connector for the data cable is a black plug with sixteen pins. These are 1, 2, 3, 4, LI, LD, HD, HM. Next to the black plug, is a 470-ohm terminating resistor with the letters "DM" to the left of it. Locate this resistor. On the other side of the resistor is another black plug. This plug has the letters "RM" to the left of it and the letters "PJ5" to the right of it. It has sixteen pins. For the terminating resistor to function, all pins must be jumpered EXCEPT the two next to the letters "RM". When the resistor is not needed, none of the pins should be jumpered.

KAYPRO 10: Jumper the two pins in the "1" position, the two pins in the "LD" position, and the two pins in the "HM" position. The terminating resistor is needed.

A DRIVE: Jumper the two pins in the "1" position, the two pins in the "LD" position, and the two pins in the "HM" position. The terminating resistor is not needed.

B DRIVE: Jumper the two pins in the "2" position, the two pins in the "LD" position, and the two pins in the "HM" position. The terminating resistor is needed.

Note: Some Toshiba drives are manufactured using a circuit board that's different in appearance from the one in the above illustration. Although the board appears different, the circuitry is the same and the drive should be jumpered using the above instructions.

Figure 9.13
Hi-Tech diskette drive

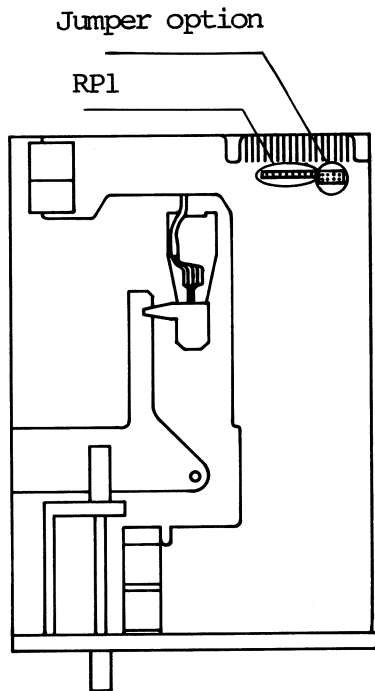

HI-TECH

Next to the connector for the data cable is a black plug with eight pins. These pins are DS0, DS1, DS2, DS3.

KAYPRO 10: Jumper the two pins in the "DS0" position. Insert a 470-ohm SIP terminating resistor into RPl.

A DRIVE: Jumper the two pins in the "DS0" position. No terminating resistor is necessary.

B DRIVE: Jumper the two pins in the "DS1" position. Insert a 470-ohm terminating resistor into RPl.

Figure 9.14
Tandon full-height
diskette drive

Option shunt 1E

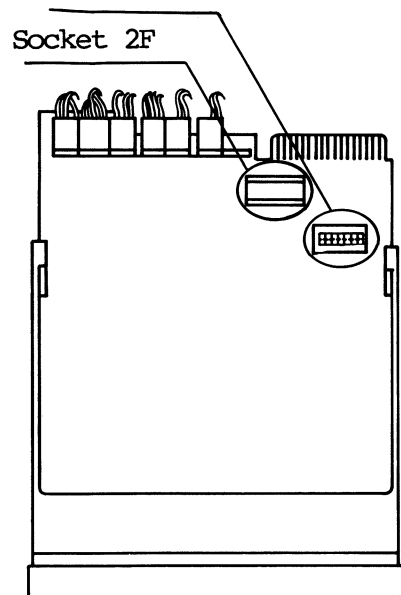

TANDON

Used only in KAYPRO II AND KAYPRO 4.

A DRIVE: Pins 1-14 and 2-13 should be jumpered in option shunt block 1E.

B DRIVE: Pins 1-14 and 3-12 should be jumpered in option shunt block 1E. Insert a 470-ohm terminating resistor into socket 2F.

9.4 HIGH-DENSITY (DRIVETEC) DRIVES

The high-density diskette drives are currently being offered in the KAYPRO ROBIE, 4X and 12X. These are 5-1/4 inch, double-sided drives with 192 tracks per inch. Each drive has 160 cylinders with a total of 320 tracks and a formatted storage capacity of 2.6 megabytes.

HIGH-DENSITY DISKETTES

The diskettes used with the high-density drives MUST be pre-formatted 17 sector, 192 TPI diskettes.

DRIVE CONFIGURATION

Next to the connector for the data cable is a drive select switch-- DS1 through DS4.

A DRIVE: DS1 should be in the "on" position. All other switches should be in the "off" position.

B DRIVE: DS2 should be in the "on" position. All other switches should be in the "off" position.

12X: DS1 should be in the "on" position. All other switches should be in the "off" position.

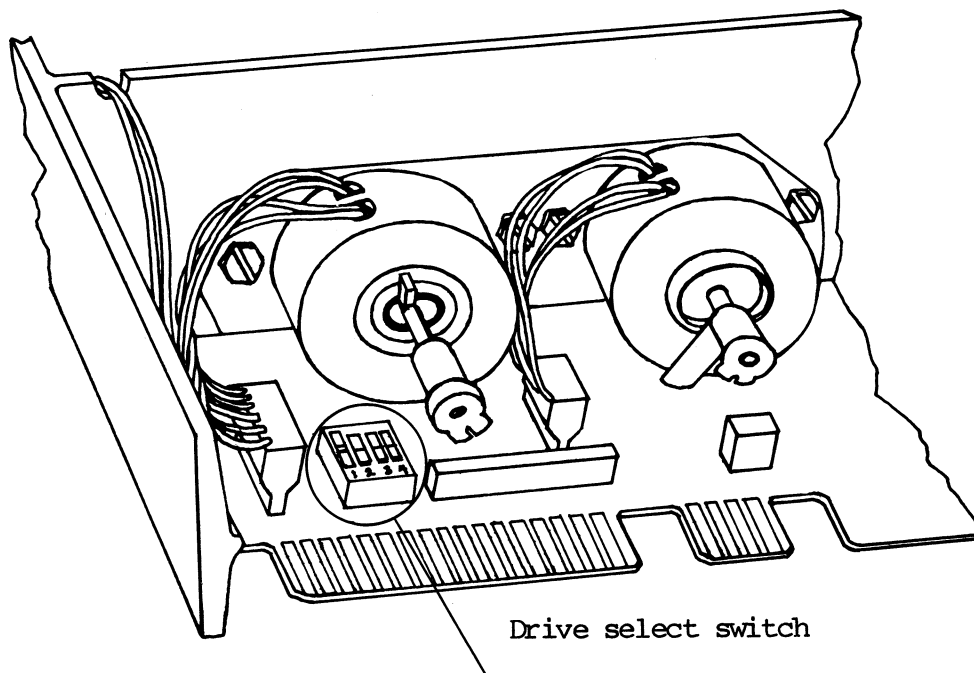

9.5 DISKETTE DRIVE REMOVAL

1. Turn off the machine and disconnect the AC power (5.1).
2. Remove the chassis hood (5.1).
3. Remove the ribbon cable, power plug, and ground wire from the rear of the drive.
4. Remove the four screws that secure the drive in the drive shield.
5. Slide the drive out of the drive shield through the front of the machine.

Note: If the drive is hard to slide out of the drive shield unit, loosen the screws holding the other drive in place.

DISKETTE DRIVE INSTALLATION

1. Configure the new drive. (A Drive or B Drive) Refer to pages 9—4 to 9—8 explaining drive configuration.
2. Slide the drive into the drive shield.
3. Align the mounting holes on the drive with the holes on the drive shield.
4. Insert four screws through the shield and into the drive mounting holes.
5. After all the screws are inserted, tighten them securely.
6. Replace the ribbon cable, power plug, and ground wire on the rear of the new drive.

10.0 HARD DISK DRIVES (KAYPRO 10 and 12K)

10.1 INTRODUCTION

Kaypro Corporation uses hard disk drives from a number of different manufacturers. As with the diskette drives, all models of hard disk drives are functionally interchangeable.

No adjustments are meant to be made by dealers (or are made by Kaypro technicians) on hard drives. And, since recovering information from a hard disk which has "crashed" requires a clean room, no directions for performing such an operation are included in this manual. Be aware that true head crashes are very rare occurrences. Most apparent hard disk problems are actually problems within other components and can be corrected without replacing the hard drive itself. Refer to the symptom-fix guide for help in troubleshooting apparent hard drive problems.

We cannot stress strongly enough that dealers instruct their customers to ALWAYS back up their data while working on a hard disk. In many cases NOTHING can be done about the loss of data in a hard-drive failure.

10.2 DESCRIPTION

The hard disk drives used in the KAYPRO 10 and the 12X are industry standard, 5-1/4 inch half-height drives offering Winchester technology. This technology includes sealed media and drive heads, with an air filtration system that prevents contamination. Since the drives are sealed, there are no dealer serviceable components on the drive. The only authorized dealer service to the hard disk drives is drive configuration.

HARD DRIVE CONFIGURATION con't.

SEAGATE

Figure 10.4
Seagate Hard Drive

Option shunt block

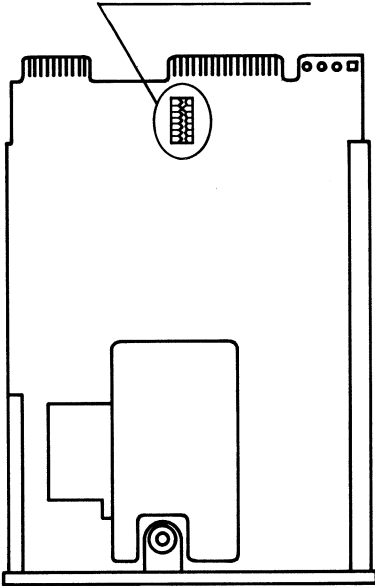

There are two types of option jumpers available on the Seagate drives. One is an option shunt block and the other is a row of jumper pins that are jumpered in pairs. Illustrations of both types are shown below for reference.

Next to the connector for the data cable, is a 16 pin option shunt block. Pins 7 and 10 should be jumpered.

Figure 10.5
Seagate Hard Drive

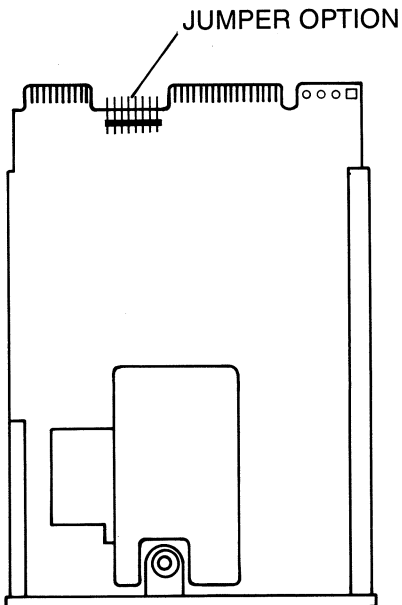

Next to the connector for the data cable is a double row of sixteen pins. With the front of the drive facing toward you and the P.C. board side facing up, jumper the two pins in the second position from the left. These are pins 7 and 10.

10.3 HARD DRIVE CONFIGURATION

MICROSCIENCE

Figure 10.1
Microscience
9 Position Switch



Figure 10.2
Microscience
10 Position Switch



There are two types of drive selection switch banks available on Microscience drives. One type has nine (9) switches and one type has ten (10) switches. These switches are located on the drive PCB next to the power plug.

9 POSITION SWITCH: Pins 1, 2, and 4 should be in the "up" position .

10 POSITION SWITCH: Pins 1, 3, 4, and 10 should be in the up position.

Refer to Figures 10.1 and 10.2 for Microscience drive configuration.

SHUGART

The Shugart hard drives should be jumpered according to figure 10.3. Next to the power connector on the rear of the drive, there are 13 sets of shorting plugs. With the rear of the drive facing you and the power connector on the right side, locate these shorting plugs. Starting on the right side (the side nearest the power connector), jumper the first eight sets of plugs, do not jumper the ninth and tenth sets, jumper the eleventh set, do not jumper the twelfth and thirteenth sets of plugs.

Figure 10.3
Shugart Hard Drive

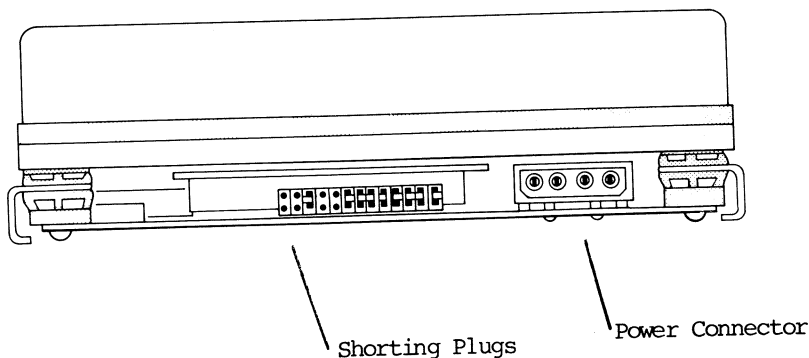

10.4 HARD DRIVE OR FLOPPY DRIVE REMOVAL FOR KAYPRO 10 OR 12X

For all hard drives and all diskette drives used in KAYPRO 10 and 12X computers.

Note: If the KAYPRO 10 has an Epson or Tokyo Electric diskette drive, it will be necessary to tilt the drive unit at an angle while removing or installing the drive. Refer to section 9.2 to determine the brand of drive.

Note: As you remove the cables on the KAYPRO 10 or 12X, it's a good idea to label them. This will insure that they get replaced correctly. Also, the end of the data cable that has a different color wire (usually red) goes to pin #1 on the connector.

1. Turn off the machine and disconnect the AC power (5.1).
2. Remove the chassis hood (5.1).
3. Remove the two diagonal braces from the right side of the chassis.
4. Tilt the machine up so that the front of the machine is sitting on the work surface and parallel to the floor.
5. Remove the six screws from the bottom of the chassis that are under the drives. Set the machine back down.
6. Remove the ribbon cables from the mainboard.
7. Slide entire drive shield unit slightly to the rear, to make room for the face of the floppy to clear the opening.
8. Lift entire drive shield unit slightly and slide out the side of the chassis.

REMOVING THE DRIVES FROM THE DRIVE SHIELD

1. Remove the ribbon cables, power plug and the ground wire from the back of the drive (hard drive or floppy). Label these.
2. Remove the two screws that attach the bottom of the drive to the drive shield (hard drive or floppy).
3. Remove the two screws that attach the top of the drive to the drive shield.
4. Slide drive out through the front of the drive shield.

HARD DRIVE OR FLOPPY INSTALLATION FOR KAYPRO 10 OR 12X

1. Configure the new drive. Refer to page 10--3 for the hard drive, pages 9--5 to 9--7 for the floppy drive.
2. Slide the drive into the shield so that the mounting holes in the drive are aligned with those in the shield.
3. Insert two screws through the top of the shield and into the mounting holes of the drive.
4. Tighten these securely.
5. Insert two screws through the bottom of the shield and into the mounting holes of the drive.
6. Tighten these securely.
7. Replace the ribbon cable(s), power plug and ground wire.
8. Slide the entire drive shield unit into the chassis.
9. Align the mounting holes in the drive shield with those in the chassis.
10. Insert the six screws through the mounting holes and tighten securely.
11. Replace the two diagonal braces.
12. Replace the ribbon cable(s) on the mainboard.
13. Replace the chassis hood.

11.0 HARD DISK CONTROLLER BOARD

11.1 DESCRIPTION

The hard disk controller board used in the KAYPRO 10 is a Western Digital board, and is not dealer-serviceable.

11.2 REMOVAL/INSTALLATION INSTRUCTIONS

HARD DRIVE CONTROLLER BOARD REMOVAL

1. Turn off the machine and disconnect AC power (5.1).
2. Remove chassis hood (5.1).
3. Remove the two diagonal braces from the right side of the machine.
4. Remove the power plug and the three ribbon cables from the hard disk controller board. Label these to insure correct replacement.
5. Remove the three screws that attach the hard disk controller board and the drive shield.
6. Remove the board.

HARD DRIVE CONTROLLER BOARD INSTALLATION

1. Position the hard disk controller board so that the mounting holes in the board are aligned with the holes in the drive shield.
2. Insert the three screws and tighten securely.
3. Replace the power plug and the three ribbon cables.
4. Replace the two diagonal braces.
5. Replace the chassis hood (5.1).

12.0 INTERFACE BOARD, KAYPRO 10 AND 12X

12.1 DESCRIPTION

The interface board that is used on the KAYPRO 10 and 12X is the interface between the mainboard and the hard drive controller board. This board is not dealer serviceable.

12.2 INTERFACE BOARD REMOVAL

1. Turn off the machine and disconnect the AC power (5.1).
2. Remove the chassis hood (5.1).
3. Remove the mainboard (6.7).
4. Remove the two ribbon cables from the interface board.
5. Remove the four screws that attach the interface board and the drive shield.
6. Remove the interface board.

INTERFACE BOARD INSTALLATION

1. Position the interface board so that the mounting holes on the board are aligned with the holes on the drive shield.
2. Insert four screws and tighten securely.
3. Replace the two ribbon cables.
4. Replace the mainboard (6.7).
5. Replace the chassis hood (5.1).

13.0 KEYBOARDS

The 76-key alphanumeric, detachable keyboard is connected to the computer by a four-wire cable and is powered by +5 VDC through the cable. The CAPS LOCK indicator light allows a quick check on whether the keyboard is receiving power.

The impedance of the connecting cable can be a critical factor in proper operation of the computer. Replacement of the standard cable with a phone cord can create malfunctions in signal transmission to the computer. This is because the wire in phone cords is too small; therefore, the impedance over the total length of the cord can be too high for reliable operation.

Wire in the standard keyboard cable is 28-gage copper, and the cable length is six feet. Should you desire a longer keyboard cable, restrict the length to not more than twelve feet, and use wire no smaller than 28 gauge.

Keyboard Cable Pinouts

- Pin 4 (Black) - Serial Data out (to keyboard), TTL level.
- Pin 3 (Red) - Ground
- Pin 2 (Green) - Serial data in (from keyboard), TTL level.
- Pin 1 (Yellow) - +5 VDC

14.0 KAYPRO ROBIE REMOVAL/INSTALLATION INSTRUCTIONS

14.1 CHASSIS COVER REMOVAL

1. Turn off the machine and disconnect the AC power(5.1).
2. Remove the four screws securing the top chassis cover (two on each side of the machine).
3. Remove the eight screws securing the bottom chassis cover (four on each side of the machine).
4. Remove the two sections of the chassis cover from the machine.

CHASSIS COVER REPLACEMENT

1. Place the lower chassis cover on the machine and align the eight mounting holes with the mounting holes in the sides of the machine.
2. Insert the eight screws into the mounting holes and tighten securely.
3. Place the top chassis cover on the machine and align the four mounting holes with the mounting holes in the sides of the machine.
4. Insert the four screws into the mounting holes and tighten securely.

14.2 DISKETTE DRIVE REMOVAL

1. Remove the top chassis cover (5.1).
2. Remove the drive support unit from the chassis. There are three screws in the front and three screws in the rear.
3. Remove the ribbon cable and the power plugs from the drives.
4. Lift the drive support unit (drives still attached) off the chassis.
5. To remove either drive from the drive support unit, turn the unit over and remove the four screws that attach the specific drive to the support unit.

DISKETTE DRIVE REPLACEMENT

1. Align the drive mounting holes with the mounting holes in the drive support unit.
2. Insert four screws into the drive support unit and into the drive. Tighten these screws securely.
3. Set the drive support unit on the chassis and align the mounting holes in the support unit with those in the chassis.
4. Insert three screws into the front mounting holes and three screws into the rear mounting holes. Tighten these securely.
5. Replace the ribbon cable and the power plugs on the drives.

15.0 TROUBLESHOOTING

15.1 INTRODUCTION

The symptom--fix guide's information is based on our experience repairing Kaypro computers. The guide is a summary of the records that Kaypro Repair maintains on each computer received.

Fixes for each problem noted are presented in **descending** order of occurrence.

15.2 KAYPRO 2 AND 4 SYMPTOM—FIX GUIDE

CONDITION	POSSIBLE CAUSE	RECOMMENDED ACTION
No power, no lights, no video	Power cord not plugged in	Check all cord connections
	Fuse is blown	Replace fuse
	Mainboard not getting power	Check harness connections; check for proper voltages; replace either harness or power supply
	Defective mainboard	Replace mainboard
	Defective fuse holder	Replace fuse holder
	Power switch shorted internally	Replace power switch
	Power supply jumpered for wrong supply	Correct jumpering on power supply
	Defective power supply	Replace power supply
	Defective harness	Replace harness
Fuse blows when power is turned on	Defective power supply	Disconnect all modules from power supply; replace power supply if fuse still blows
	One module has a short	Disconnect all modules, replace fuse, and re-connect modules, one at a time, until fuse blows. Replace that module
	Defective harness	Replace harness
High-pitched squeal or "chirp"	One module is shorted	Unplug modules, one at a time, from the harness. Replace the module whose unplugging causes the noise to stop

KAYPRO 2 AND 4 SYMPTOM—FIX GUIDE (CONT'D)

CONDITION	POSSIBLE CAUSE	RECOMMENDED ACTION
Power LED flickers	Shorted module	Disconnect modules from power, one at a time, until LED stays on; replace module whose unplugging caused LED to stay on.
	Defective power supply	Replace power supply
	Defective harness	Replace harness
No video display, or poor quality display	Brightness not adjusted	Turn up brightness knob on rear of chassis; adjust brightness pot on CRT board, if necessary
	CRT not connected	Check all connections to CRT; be sure plug on rear of CRT tube is square
	Defective CRT	Replace CRT assembly
	Defective mainboard	Replace mainboard
	Defective power supply	Replace power supply
	Defective harness	Replace harness
Video is on, but screen is filled with "garbage" characters	Defective mainboard	Replace mainboard
	Reset harness shorted to chassis	Check lugs of reset button for grounding to inside of chassis
	Defective reset harness	Replace reset harness

KAYPRO 2 AND 4 SYMPTOM—FIX GUIDE (CONT'D)

CONDITION	POSSIBLE CAUSE	RECOMMENDED ACTION
"Raster" (horizontal lines) on video	Brightness not adjusted properly	Turn up brightness knob on back of chassis; adjust brightness pot on CRT board if necessary
	Loose connection from mainboard or power supply	Check black plug from power supply to CRT board, 4-pin jumper from main board to CRT board; check that plug on rear of CRT tube is square
Strange video image	Short in brightness-adjusting knob	Check for shorts between wires in rear of brightness-adjusting knob
	Defective mainboard	Replace mainboard
Missing characters on video display	Defective mainboard	Replace mainboard
	Defective CRT	Replace CRT assembly
Will not boot	Defective diskette	Change diskettes
	Diskette has no system image	Change diskettes; use a diskette with a known good system image
	Wrong CP/M for model of machine	Check that you're not trying to boot a KP 2 with a KP 4 CP/M (KP 4 WILL boot a KP 2 CP/M)
	Defective drive B	Unplug data cable from drive B, and reset machine; if it boots, replace drive B
	Defective mainboard	Replace mainboard
	Defective drive A	Replace drive A
	Defective data cable	Replace data cable

KAYPRO 2 AND 4 SYMPTOM—FIX GUIDE (CONT'D)

CONDITION	POSSIBLE CAUSE	RECOMMENDED ACTION
Both drive LEDs are on, won't boot	Problem on power-up	Reset machine
	Diskette has no CP/M	Try known good sysgenned diskette
	Defective mainboard	Replace mainboard
	Select jumpers on drives incorrect	Check select jumpers
Drive A LED only on during reset	Drive select jumpering incorrect	Check jumpering on drive A
No LED on drive A at any time	Data cable poorly connected	Check all connections on data cable
	Defective data cable	Replace data cable
	Defective drive A	Replace drive A
	Defective mainboard	Replace mainboard
Computer boots CP/M, but no A> prompt appears	Defective diskette	Try known good, sysgenned diskette
	Defective mainboard	Replace mainboard
Rattling sound from drive when accessing	Defective drive	Replace the diskette drive
	Defective mainboard	Replace mainboard

KAYPRO 2 AND 4 SYMPTOM—FIX GUIDE (CONTINUED)

CONDITION	POSSIBLE CAUSE	RECOMMENDED ACTION
Drive will not step through all tracks on diskette	Drive connectors loose	Check all connectors on rear of drive, esp. P12 (Tandon drives)
	Defective mainboard	Replace mainboard
	Defective drive	Replace diskette drive
	Defective data cable	Replace data cable
Errors on either drive during COPY	Defective diskette	Change the diskette (if problem is on drive B, insert another blank diskette; if on drive A, try to copy from a new master)
	Defective disk drive	Replace diskette drive
	Defective mainboard	Replace mainboard
No output to parallel printer	No power to printer	Check that printer is plugged in, and selected
	Poor cable connection	Check all cable connections from computer to printer
	Printer is assigned as serial by STAT	Use STAT to assign printer device as parallel, type: STAT LST:=LPT:
	Defective mainboard	Replace mainboard
No output to serial printer	No power to printer	Check that printer is plugged in and selected
	Poor cable connection	Check all cable connections from computer to printer; also check serial port connector pins for contamination
	Printer is assigned as parallel by STAT	Use STAT to assign printer device to serial; type: STAT LST:=TTY:

KAYPRO 2 AND 4 SYMPTOM—FIX GUIDE (CONTINUED)

CONDITION	POSSIBLE CAUSE	RECOMMENDED ACTION
No output to serial printer (cont'd)	Baud rate of printer does not match baud rate of computer	Use CONFIG to set baud rate for serial port
	Defective power supply	Check voltages (esp.-12 V) at power supply output; replace power supply
	Defective harness	Check voltages (esp.-12V) at main board power connector; replace harness
	Defective mainboard	Replace mainboard
No characters on video when keys struck on keyboard	Defective keyboard coil cord	Replace coil cord
	Defective keyboard	Replace keyboard
	Keyboard connector on mainboard defective	Check for shorted contacts on keyboard plug; esp. soldering to main board
	Defective mainboard	Replace mainboard
Wrong characters or too many characters appear when a key is struck	Defective keyboard	Replace keyboard
	Defective mainboard	Replace mainboard (if "^@^@@" appears, replace 8116 IC on mainboard)

15.3 KAYPRO 10 SYMPTOM—FIX GUIDE

IMPORTANT NOTE

Do not proceed with troubleshooting a Kaypro 10 until you verify that the computer has EPROM number 81-302-n (installed at the factory), or has been upgraded in the field with kit number 81-303.

This note only applies to Kaypro 10 computers with the 81-180-n mainboard; NOT to the Kaypro 10 computers with the 81-582-n mainboard.

CONDITION	POSSIBLE CAUSE	RECOMMENDED ACTION
No power, no lights, no video	Power cord not plugged in	Check all cord connections
	Fuse is blown	Replace fuse
	Mainboard not getting power	Check harness connections, then check for proper voltages from power supply; replace either harness or power supply
	Defective mainboard	Replace mainboard
	Defective fuse holder	Replace fuse holder
	Power switch shorted internally	Replace power switch
	Power supply jumpered for wrong supply voltage	Correct jumpering on power supply
	Defective power supply	Check for proper voltage output at power supply harness connector; replace power supply
Defective harness	Replace harness	
Fuse blows when power turned on	Defective power supply	Replace power supply
	One module has a short	Disconnect all modules, replace fuse, and re-connect one by one until fuse blows again; replace it
	Defective harness	Replace harness

KAYPRO 10 SYMPTOM—FIX GUIDE (CONT'D)

CONDITION	POSSIBLE CAUSE	RECOMMENDED ACTION
High-pitched squeal or "chirp" upon power-on	One module is shorted	Unplug modules, one at a time, from the harness. Replace the module whose unplugging causes the noise to stop.
Power LED flickers	Shorted module	Disconnect modules from power one at a time until LED stays on; replace module whose unplugging causes LED to stay on
	Defective power supply	Replace power supply
	Defective harness	Replace harness
No video display, or poor quality display	Brightness not adjusted	Turn up brightness knob on rear of chassis; turn up brightness pot on CRT board, if necessary
	CRT not connected	Check all connections to CRT; ensure CRT tube plug is square
	Defective CRT	Replace CRT assembly
	Defective mainboard	Replace mainboard
	Defective power supply	Replace power supply
	Defective harness	Replace harness
Extra pixels on video	Defective mainboard	Replace mainboard
	Defective CRT	Replace CRT assembly
Inverse video only	Defective mainboard	Replace mainboard
	Defective CRT	Replace CRT assembly

KAYPRO 10 SYMPTOM—FIX GUIDE (CONT'D)

CONDITION	POSSIBLE CAUSES	RECOMMENDED ACTION
No graphics on video	Damaged system image	Run PUTSYS and PUTOVL
	Defective mainboard	Replace mainboard
	Defective CRT	Replace CRT assembly
No video; drives running	Poor cable connection	Check all cable connections, (esp. to/from video harness plug)
	Defective mainboard	Replace mainboard
	Defective CRT	Replace CRT assembly
	Elston CRT: fuse blown	Check continuity of pico-fuse on Elston video board (just above power connector) If open, replace
Hard drive boots, but no cursor on video	Defective system image	Run PUTSYS and PUTOVL from the diskette drive, push RESET
	Defective mainboard	Replace mainboard
Diskette drive boots, but no cursor on video	Defective system image on diskette	Run GENFLPY on the diskette; push RESET
	Defective mainboard	Replace mainboard
	Defective drive	Replace diskette drive
Diskette drive won't boot; or BDOS error on diskette drive	Diskette not centered	Remove diskette, center diskette in its jacket; try again
	No system image on diskette	Run GENFLPY on the diskette; push RESET
	Defective diskette	Try a known good diskette with a known good system image

KAYPRO 10 SYMPTOM—FIX GUIDE (CONT'D)

CONDITION	POSSIBLE CAUSE	RECOMMENDED ACTION
Diskette drive won't boot; or BDOS errors	Poor cable connection	Check all cable connections; esp. those to/from drives and the controller board
	No system image	Run GENFLPY
	Incorrect cable orientation	Verify that all cables are oriented properly
	Defective mainboard	Replace mainboard
	Defective drive	Replace diskette drive
Diskette drive won't format a disk	Diskette off center	Ensure that diskette is centered within its jacket
	Defective diskette drive	Replace diskette drive
	Defective mainboard	Replace mainboard
Diskette drive has BDOS errors or won't work if warm	Defective drive heads	Replace diskette drive
	Defective mainboard	Replace mainboard
Diskette drive makes a rattling noise, and won't boot	Defective diskette drive	Replace diskette drive
	Defective mainboard	Replace mainboard
High-pitched whine when diskette drive runs	Defective diskette drive ("singing heads")	Replace diskette drive

KAYPRO 10 SYMPTOM—FIX GUIDE (CONT'D)

CONDITION	POSSIBLE CAUSE	RECOMMENDED ACTION
Hard drive will not boot; or boots with "System Status 02" ("Read Fault") message	Machine not upgraded	Verify installation of eeprom number 81-302-x (at the factory), or kit 81-303; install if needed
	Poor cable connection	Check all cable connections
	Incorrect cable orientation	Verify that all cables are oriented properly
	System image degraded	Boot on a disk in the diskette drive; then log onto hard drive. Run FINDBAD (or CHECK on cylinders 0 and 1) if no errors are found, run PUTSYS and PUTOVL
	Defective controller board	Replace controller board
	Degraded format on hard disk	Boot on a disk in the diskette drive; run FORMAT on entire hard drive; then run PUTSYS and PUTOVL
	Defective mainboard	Replace mainboard
	Defective hard drive	Replace hard drive
	Defective power supply	Replace power supply

Except in the case of an obvious head crash or brake assembly failure, ALWAYS suspect other modules first when a defect appears to be within the hard drive.

No output to parallel printer	No power to printer	Check that printer is plugged in, and selected
	Poor cable connection	Check all cable connections from computer to printer
	Printer is assigned as serial by STAT	Use STAT to assign printer device as parallel; type: STAT LST:=LPT:
	Defective mainboard	Replace mainboard

KAYPRO 10 SYMPTOM—FIX GUIDE (CONT'D)

CONDITION	POSSIBLE CAUSE	RECOMMENDED ACTION
No output to serial printer	No power to printer	Check that printer is plugged in and selected
	Poor cable connection	Check all cable connections from computer to printer; also check serial port connector pins for contamination
	Printer is assigned as parallel by STAT	Use STAT to assign printer device to serial; type: STAT LST:=TTY:
	Baud rate of printer does not match baud rate of computer	Use CONFIG to set baud rate for serial port
	Defective power supply	Check voltages (esp.-12 V) at supply output; replace supply
	Defective harness	Check voltages (esp.-12V) at main board power connector; replace harness
	Defective mainboard	Replace mainboard

KAYPRO ROBIE SYMPTOM—FIX GUIDE

CONDITION	POSSIBLE CAUSE	RECOMMENDED ACTION
No video display	Defective CRT	Replace CRT assembly
	Defective mainboard	Replace mainboard
	Defective power supply	Replace power supply
	Defective harness	Replace harness
Video is on, but screen is filled with "garbage" characters	Defective mainboard	Replace mainboard
	Reset harness shorted to chassis	Check lugs of reset button for grounding to inside of chassis
	Defective reset harness	Replace reset harness
"Raster" (horizontal lines) on video	Brightness not adjusted properly	Turn up brightness knob on back of chassis; adjust brightness pot on CRT board if necessary
	Loose connection from mainboard or power supply	Check black plug from power supply to CRT board, 4-pin jumper from mainboard to CRT board; check that plug on rear of CRT tube is square
Strange video image	Defective mainboard	Replace mainboard
Missing characters on video display	Defective mainboard	Replace mainboard
Will not boot	Defective diskette	Change diskettes
	Diskette has no system image	Change diskettes; use a diskette with a known good system image
	Wrong diskette for model of machine	ROBIE will only boot on 17 sector, 192 TPI diskettes
	Defective drive B	Unplug data cable from drive B, and reset machine; if it boots, replace B drive

KAYPRO ROBIE SYMPTOM—FIX GUIDE (CON'T.)

CONDITION	POSSIBLE CAUSE	RECOMMENDED ACTION
No video display	Defective CRT	Replace CRT assembly
	Defective mainboard	Replace mainboard
	Defective power supply	Replace power supply
	Defective harness	Replace harness
Video is on, but screen is filled with "garbage" characters	Defective mainboard	Replace mainboard
	Reset harness shorted to chassis	Check lugs of reset button for grounding to inside of chassis
	Defective reset harness	Replace reset harness
"Raster" (horizontal lines) on video	Brightness not adjusted properly	Turn up brightness knob on back of chassis; adjust brightness pot on CRT board if necessary
	Loose connection from mainboard or power supply	Check black plug from power supply to CRT board, 4-pin jumper from mainboard to CRT board; check that plug on rear of CRT tube is square
Strange video image	Defective mainboard	Replace mainboard
Missing characters on video display	Defective mainboard	Replace mainboard
Will not boot	Defective diskette	Change diskettes
	Diskette has no system image	Change diskettes; use a diskette with a known good system image
	Wrong diskette for model of machine	ROBIE will only boot on 17 sector, 192 TPI diskettes
	Defective drive B	Unplug data cable from drive B, and reset machine; if it boots, replace B drive

KAYPRO ROBIE SYMPTOM—FIX GUIDE (CON'T.)

CONDITION	POSSIBLE CAUSE	RECOMMENDED ACTION
Will not boot	Defective mainboard	Replace mainboard
	Defective drive A	Replace drive A
	Defective data cable	Replace data cable
Both drive LEDs are on, won't boot	Problem on power-up	Reset machine
	Diskette has no CP/M	Try known good sysgenned diskette
	Defective mainboard	Replace mainboard
	Select jumpers on drives incorrect	Check select jumpers
Drive A LED only on during reset	Drive select jumpering incorrect	Check jumpering on drive A
No LED on drive A at any time	Data cable poorly connected	Check all connections on data cable
	Defective data cable	Replace data cable
	Defective drive A	Replace drive A
	Defective mainboard	Replace mainboard
Computer boots CP/M, but no master menu appears	Defective diskette	Try known good, sysgenned diskette
	Defective drive A	Replace drive A
	Defective mainboard	Replace mainboard
Rattling sound from drive when accessing	Defective drive	Replace the diskette drive
	Defective mainboard	Replace mainboard

KAYPRO ROBIE SYMPTOM—FIX GUIDE (CONT'D.)

CONDITION	POSSIBLE CAUSE	RECOMMENDED ACTION
Drive will not step through all tracks on diskette	Drive connectors loose	Check all connectors on rear of drive
	Defective mainboard	Replace mainboard
	Defective drive	Replace diskette drive
	Defective data cable	Replace data cable
Errors on either drive during COPY	Defective diskette	Change the diskette (if problem is on drive B, insert another blank diskette; if on drive A, try to copy from a new master)
	Defective disk drive	Replace diskette drive
	Defective mainboard	Replace mainboard
No output to parallel printer	No power to printer	Check that printer is plugged in, and selected
	Poor cable connection	Check all cable connections from computer to printer
	Printer is assigned as serial by STAT	Use STAT to assign printer device as parallel, type: STAT LST:=LPT:
	Defective mainboard	Replace mainboard
No output to serial printer	No power to printer	Check that printer is plugged in and selected
	Poor cable connection	Check all cable connections from computer to printer; also check serial port connector pins for contamination

KAYPRO ROBIE SYMPTOM—FIX GUIDE (CONT'D.)

CONDITION	POSSIBLE CAUSE	RECOMMENDED ACTION
No output to serial printer (cont'd)	Printer is assigned as parallel by STAT	Use STAT to assign printer device to serial; type: STAT LST:=TTY:
	Baud rate of printer does not match baud rate of computer	Use CONFIG to set baud rate for serial port
	Defective power supply	Check voltages (esp.-12 V) at power supply output; replace power supply
	Defective harness	Check voltages (esp.-12V) at main board power connector; replace harness
	Defective mainboard	Replace mainboard
No characters on video when keys struck on keyboard	Defective keyboard coil cord	Replace coil cord
	Defective keyboard	Replace keyboard
	Keyboard connector on mainboard defective	Check for shorted contacts on keyboard plug; esp. soldering to main board
	Defective mainboard	Replace mainboard
Wrong characters	Defective keyboard	Replace keyboard

15.5 KAYPRO 2/84 AND KAYPRO 2X SYMPTOM--FIX GUIDE

See KAYPRO 2 AND 4 SYMPTOM--FIX GUIDE for the 2/84. The problems and solutions will not be different.

For troubleshooting information on the KAYPRO 2X, see the KAYPRO 2 AND 4 SYMPTOM--FIX GUIDE for all problems.

15.6 KAYPRO 4X SYMPTOM-FIX GUIDE

For help in troubleshooting the KAYPRO 4X, see the KAYPRO ROBIE SYMPTOM-FIX GUIDE.