

**SYSTEM 86/330
INSTALLATION AND
MAINTENANCE MANUAL**

Order Number: 143897-001

REV.	REVISION HISTORY	PRINT DATE
-001	Original Issue	11/81

WARNING

HAZARDOUS VOLTAGE AND CURRENT LEVELS ARE PRESENT WITHIN THIS SYSTEM. TO AVOID RISKS OF ELECTRIC SHOCK OR FIRE, ONLY QUALIFIED TECHNICAL PERSONS SHOULD ATTEMPT PROCEDURES CONTAINED WITHIN THIS MANUAL.

Additional copies of this manual or other Intel literature may be obtained from:

Literature Department
Intel Corporation
3065 Bowers Avenue
Santa Clara, CA 95051

The information in this document is subject to change without notice.

Intel Corporation makes no warranty of any kind with regard to this material, including, but not limited to, the implied warranties of merchantability and fitness for a particular purpose. Intel Corporation assumes no responsibility for any errors that may appear in this document. Intel Corporation makes no commitment to update nor to keep current the information contained in this document.

Intel Corporation assumes no responsibility for the use of any circuitry other than circuitry embodied in an Intel product. No other circuit patent licenses are implied.

Intel software products are copyrighted by and shall remain the property of Intel Corporation. Use, duplication or disclosure is subject to restrictions stated in Intel's software license, or as defined in ASPR 7-104.9(a)(9).

No part of this document may be copied or reproduced in any form or by any means without the prior written consent of Intel Corporation.

The following are trademarks of Intel Corporation and its affiliates and may be used only to identify Intel products:

BXP
CREDIT
i
ICE
iCS
im
Insite

Intel
Intel
Intelelevision
Intellec
iRMX
iSBC
iSBX

Library Manager
MCS
Megachassis
Micromainframe
Micromap
Multibus
Multimodule

Plug-A-Bugle
PROMPT
RMX/80
System 2000

LIST OF SAFETY PRECAUTIONS

Use recommended lifting techniques. System 86/330 weighs in excess of 75 pounds.

Unlock Winchester shipping restraint before applying power. Failure to comply may cause damage to drive components.

Never attempt to service any sub-assembly with the AC power cord connected. Hazardous voltages are present within the chassis with the AC cord connected to a power source.

Exercise care when turning the unit over to gain access to the four screws securing the bottom cover to the chassis. If the Winchester drive is subjected to shock where the platters are parallel to the shock surface, media pitting may result.

WARNING

The System 86/330 generates, uses, and radiates radio frequency energy. Interference to radio communications (RFI) may result if the equipment is not installed and operated in accordance with the procedures in this manual. The equipment was tested for compliance and complies with the limits for a Class A Computing Device pursuant to Subpart J of Part 15 of FCC rules designed to provide reasonable protection against such interference (RFI) for operation in a commercial environment. The users are responsible, at their own expense, to take whatever measures are required to correct the likely occurrence of an unacceptable level of interference (RFI) if the equipment is operated in a residential area.

CONTENTS

CHAPTER 1	
GENERAL INFORMATION	
Introduction.....	1-1
System Features.....	1-1
Physical Description.....	1-2
Chassis.....	1-2
Power Supply.....	1-3
Card Cage.....	1-3
Processor Board.....	1-3
Memory Board.....	1-4
Disk Controller.....	1-4
Winchester Disk Drive.....	1-4
Flexible Disk Drive.....	1-5
Power On Functional Description.....	1-5
Specifications.....	1-10
CHAPTER 2	
INSTALLATION	
Introduction.....	2-1
Incoming Inspection.....	2-1
Installation Considerations.....	2-1
Unpacking.....	2-2
Installation Procedure.....	2-4
Rack Mounting.....	2-4
Instructions for Unlocking Winchester Shipping Restraint.....	2-6
Serial I/O Cable Fabrication Data.....	2-8
Parallel I/O Cable Fabrication Data.....	2-9
Software Installation.....	2-10
CHAPTER 3	
OPERATION	
Introduction.....	3-1
AC Power On/Off Switch.....	3-1
Front Panel Controls and Indicators.....	3-2
Reset Switch.....	3-2
Run Indicator.....	3-2
Halt Indicator.....	3-2
Intrpt Switch.....	3-3
System Initialization.....	3-3
System Confidence Test (SCT).....	3-3
Test 1. USART/Timer.....	3-4
Test 2. PIC Initialization.....	3-5
Test 3. ROM Checksum.....	3-6
Test 4. PPI Initialization.....	3-6
Test 5. NDP.....	3-6
Test 6. RAM.....	3-6
Test 7. Parity.....	3-7
Test 8. Winchester.....	3-7
Test 9. Flexible Disk.....	3-7
Test 10. Contrlr INT.....	3-7

CONTENTS (continued)

	PAGE
CHAPTER 4	
MAINTENANCE	
Introduction.....	4-1
Preventive Maintenance.....	4-1
Troubleshooting.....	4-1
Preliminary Checks.....	4-4
Removal and Replacement Procedures.....	4-4
Front Panel Removal and Replacement Procedure.....	4-5
Top Cover Removal and Replacement Procedure.....	4-6
Filler Panel Removal and Replacement Procedure.....	4-7
Top Support Angle Bracket Removal and Replacement Procedure....	4-8
Winchester Drive Removal and Replacement Procedure.....	4-9
Flexible Disk Drive Removal and Replacement Procedure.....	4-10
Power Supply Removal and Replacement Procedure.....	4-11
Card Cage Removal and Replacement Procedure.....	4-13
AC Power Switch Removal and Replacement Procedure.....	4-16
Filter 2 Removal and Replacement Procedure.....	4-17
Bottom Cover Removal and Replacement Procedure.....	4-18
Filter 1 Removal and Replacement Procedure.....	4-20
AC Power Lamp Removal and Replacement Procedure.....	4-21
CHAPTER 5	
SERVICE INFORMATION	
Introduction.....	5-1
Service and Repair Assistance.....	5-1
CHAPTER 6	
MAINTENANCE DIAGRAMS	
Introduction.....	6-1
APPENDIX A	
INSTALLING ADDITIONAL WINCHESTER DRIVES.....	A-1
APPENDIX B	
ADDING FLEXIBLE DISK DRIVES.....	B-1

CONTENTS (continued)

FIGURES

		PAGE
1-1.	System 86/330.....	1-1
1-2.	System 86/330 Internal Location Diagram.....	1-2
1-3.	SCT Test Sequence	1-8
1-4.	System 86/330 Physical Address Allocations.....	1-9
2-1.	Unpacking.....	2-3
2-2.	System 86/331 Slide Mounting Location.....	2-5
2-3.	Typical Slide Mounting Inside Cabinet.....	2-6
2-4.	Winchester Shipping Restraints.....	2-7
3-1.	System 86/330 Power on Sequence.....	3-1
3-2.	System 86/330 Controls and Indicators.....	3-2
3-3.	Successfully Completed SCT Test Results.....	3-4
4-1.	System 86/330 Troubleshooting Guide.....	4-2
4-2.	Front Panel Location.....	4-5
4-3.	Top Cover Location.....	4-6
4-4.	Filler Panel Retaining Screw Location.....	4-7
4-5.	Top Angle Bracket Retaining Screw Locations.....	4-8
4-6.	Winchester Drive Retaining Screw Locations.....	4-9
4-7.	Flexible Disk Drive Retaining Screw Locations.....	4-10
4-8.	Filter 2 Terminal Wire Locations.....	4-11
4-9.	Pin Adapter Retaining Screw Locations.....	4-12
4-10.	Power Supply Retaining Screw Locations.....	4-12
4-11.	Card Cage Board Clamp Retaining Screw Locations.....	4-14
4-12.	Card Cage Retaining Screw Locations.....	4-14
4-13.	Installation Sequence of Card Cage Retaining Screw.....	4-15
4-14.	Switch Retaining Clips.....	4-16
4-15.	Rear View of Switch.....	4-17
4-16.	Filter 2 Terminal Locations.....	4-18
4-17.	Bottom Cover Retaining Screw Locations.....	4-19
4-18.	Filter and Terminal Locations.....	4-20
4-19.	AC Power Switch Lamp Location.....	4-21
6-1.	System 86/330 Exploded View.....	6-3
6-2.	System 86/330 Interconnection Diagram.....	6-5
6-3.	System 86/330 Cable Routing Diagram.....	6-6
6-4.	iSBC 86/12A Jumper Configuration.....	6-7
6-5.	iSBC 056 Jumper Configuration.....	6-8
6-6.	iSBC 215 Jumper Configuration.....	6-9
6-7.	iSBX 218 Jumper Configuration.....	6-10
6-8.	iSBC 300 Jumper Configuration.....	6-11
6-9.	Flexible Disk Drive Cables.....	6-12
6-10.	Flexible Disk Drive Signal Cable (143494) Pin Assignments..	6-13
6-11.	Flexible Disk Drive DC Cable (143493) Connector Pinout.....	6-14
6-12.	Flexible Disk Drive AC Cable (143492) Connector Pinout.....	6-14
6-13.	Winchester Drive Cable Interconnection.....	6-15
6-14.	Pin Adapter Board Connector Locations.....	6-15
6-15.	Priam Drive Cable Routing.....	6-16
6-16.	Priam Connector Pinout.....	6-17
6-17.	Priam DC Connector Pinout.....	6-18
6-18.	System 86/330 AC Wiring Diagram.....	6-19
6-19.	System 86/330 Backplane Wiring Diagram.....	6-21
A-1.	Drive Select and Terminator Location.....	A-2
B-1.	Drive Select and Terminator Location.....	B-2

CONTENTS (continued)

TABLES

	PAGE
1-1. On Board I/O Port Address Assignments.....	1-7
1-2. System 86/330 Specifications.....	1-10
1-3. Winchester Drive Specifications.....	1-11
1-4. Flexible Disk Drive Specifications.....	1-12
1-5. Power Supply Specifications.....	1-13
2-1. Serial I/O Cable Fabrication Data.....	2-8
2-2. Parallel I/O Cable Fabrication Data.....	2-9
3-1. Interrupt Assignments.....	3-5
3-2. Interrupt Vector Addresses.....	3-5
4-1. Preventive Maintenance Schedule.....	4-1
4-2. Abnormal SCT Test Results.....	4-3
6-1. Replacement Parts List.....	6-1

CHAPTER 1. GENERAL INFORMATION

1-1. INTRODUCTION

This chapter lists the features, provides both a physical and a functional description, and lists the specifications of the System 86/330.

1-2. SYSTEM FEATURES

System 86/330, Figure 1-1, is a dedicated Real-time, multi-tasking computer with the following features:

- o Multi-tasking Operating System
- o Two Multibus slots for customer expansion
- o Full development and run-time software support
- o Extensive diagnostic support
- o Convenient form factor 16 3/4" by 12 3/4" by 21"
- o High speed 16-bit microprocessor
- o 16K bytes of ROM for bootloader and diagnostics
- o Floating point hardware
- o 320K bytes of RAM memory
- o Byte parity protection on system memory
- o High performance Winchester drive
- o Winchester automatic defect handling
- o Multiple sector transfer capability
- o Extensive error checking and reporting over the disk sub-system
- o High level language support

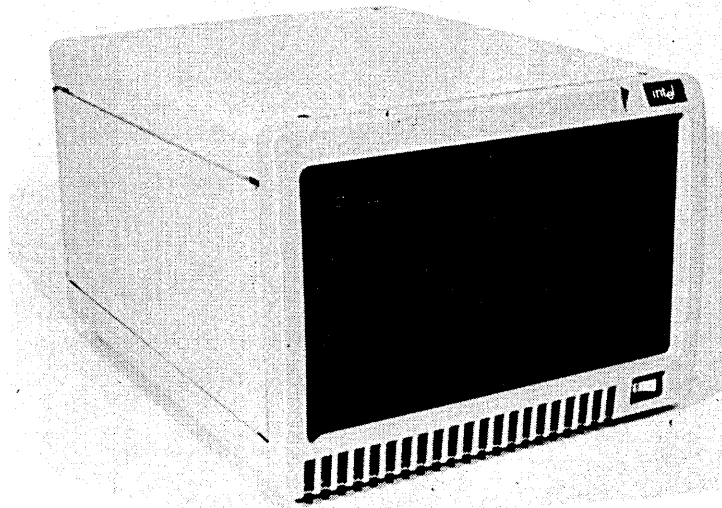

Figure 1-1. System 86/330

GENERAL INFORMATION

1-3. PHYSICAL DESCRIPTION

The System 86/330 consists of a chassis in which a six-slot card cage, a processor board, a disk controller board, a memory board, a Winchester 8-inch drive, an 8-inch flexible disk drive, and a switching power supply reside.

1-4. CHASSIS

The chassis, Figure 1-2, is designed such that access for servicing the unit is both easy and convenient. The top cover is attached by four quarter-turn fasteners. The upper rear panel securing the power supply is attached with six screws. The front panel and both side panels are attached with ball-stud fasteners. The bottom cover is attached with four screws.

Mounted onto the front of the chassis is an illuminated power switch located at the lower right corner and a front panel with two pushbutton switches and two indicators.

The rear panel of the chassis supports I/O connectors. Four of the connectors are dedicated. Connector J1 provides the RS232 serial I/O port for a CRT/Keyboard. Connector J2 provides the parallel I/O communications port for an industry standard Centronics compatible interface printer. Connector J3 provides a means to daisy chain additional Winchester drives. Connector J4 provides a means to daisy chain additional flexible disk drives.

Refer to the iSBC 680/681 MULTISTORE CHASSIS HARDWARE REFERENCE MANUAL for additional information.

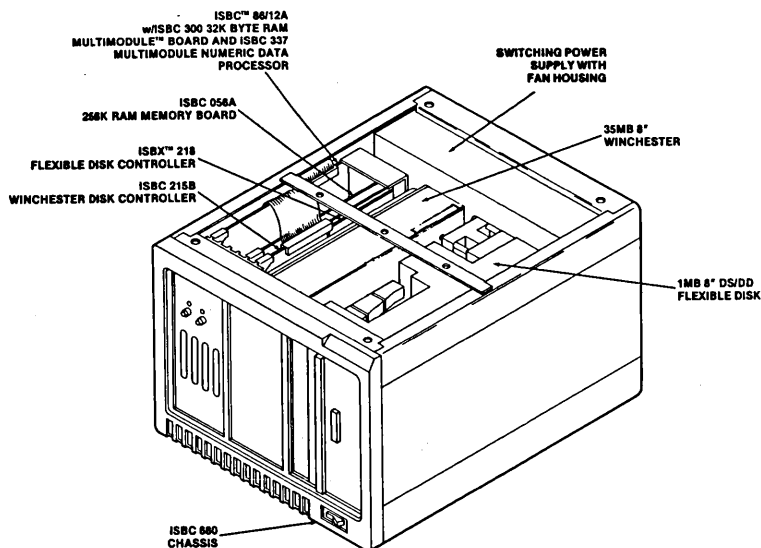

Figure 1-2. System 86/330 Internal Location Diagram

GENERAL INFORMATION

1-5. POWER SUPPLY

The power supply is mounted to the chassis at the rear panel. It is a switching power supply providing power to all elements of the system with sufficient reserve (92.5W) remaining for user installable options. Refer to paragraph 1-13 for the power supply specifications.

1-6. CARD CAGE

The six-slot card cage is mounted within the chassis on the extreme left side. DC power to all the slot connections is routed from the power supply via connector P3. All boards are installed such that the component side faces to the right when viewed from the front. In the standard configuration, the processor board is installed in the far left side which is slot connector J1. Slot connector J2 is not used due to the installation of both the iSBC 300A and iSBC 337 Multimodules onto the iSBC 86/12A board. Slot connectors J3 and J4 are available for customer usage. The RAM memory board is installed in slot connector J5. The disk controller board is installed in slot connector J6 which is the right most side of the card cage.

Hereafter, the descriptions within this manual assumes that the System is in the standard configurations.

The front panel is mounted in front of the card cage and interfaces to the backplane via connector P2. This card cage backplane supports the Intel Multibus System Bus configuration for 8- or 16-bit data transfers and 20-bit addresses.

Bus contention between the processor board and the disk controller or other Multibus master is resolved by a parallel resolution circuit within the backplane. Highest priority is assigned to the disk controller with the processor having the lowest priority.

1-7. PROCESSOR BOARD

The processor board consists of an iSBC 86/12A Single Board Computer on which is mounted a RAM expansion Multimodule (iSBC 300A) and a Numeric Data Processor (iSBC 337) Multimodule.

The iSBC 86/12A board is a Multibus System Bus master with a 16-bit microprocessor (8086), 16K of ROM memory, 32K of dual port RAM memory, a Programmable Interval Timer (8253) that controls baud rates, a Programmable Interrupt Controller (8259A), a programmable USART (8251A) for RS232 serial I/O communications, and a Programmable Peripheral Interface (8255A) configured for an industry standard Centronix compatible interface printer.

The iSBC 300A board is a RAM expansion Multimodule extending the available dual port RAM to 64K bytes.

GENERAL INFORMATION

The iSBC 337 Numeric Data Processor enhances math computing performance.

Refer to the iSBC 86/12A SINGLE BOARD COMPUTER HARDWARE REFERENCE MANUAL for a functional description of the iSBC 86/12A board.

1-8. MEMORY BOARD

The RAM memory board is an iSBC 056 board providing the system with 256K bytes of additional memory.

Refer to the iSBC 056A RAM BOARD HARDWARE REFERENCE MANUAL for a functional description of the iSBC 056 board.

1-9. DISK CONTROLLER

The disk controller consists of an iSBC 215 Winchester disk controller to which is attached an iSBX 218 Flexible disk controller Multimodule.

The iSBC 215 Winchester disk controller is an 8089 based I/O processor which controls the Winchester drive and supports the Multibus System Bus environment. It provides full sector buffering, on-board ECC, and automatic defective track handling. It also features automatic error recovery and retry, and transparent data error corrections. It can detect errors of up to 32 bits in length and can correct errors of up to 11 bits in length.

Refer to the iSBC 215 WINCHESTER DISK CONTROLLER HARDWARE REFERENCE MANUAL for a functional description of the iSBC 215 board.

The iSBX 218 Flexible disk controller is a double-wide Multimodule which is attached to the iSBC 215 board. It controls all command, data, and status between the flexible disk drive and the processor board via the iSBC 215 board.

Refer to the iSBX 218 FLEXIBLE DISK CONTROLLER HARDWARE REFERENCE MANUAL for a functional description of the iSBX 218 board.

1-10. WINCHESTER DISK DRIVE

The Winchester disk drive is a 35M byte, non-removable media, 8-inch disk drive. The head/disk assembly is completely enclosed and is not accessible for servicing. The Winchester drive is mounted in the center of the peripheral bay with a filler panel mounted in front of the drive.

Refer to paragraph 1-13 for the Winchester drive specifications.

GENERAL INFORMATION

1-11. FLEXIBLE DISK DRIVE

The flexible disk drive is a 1M byte double-sided, double-density drive. It is mounted in the right most peripheral bay such that the door access button is positioned to the right of the diskette door as viewed from the front.

Refer to paragraph 1-13 for Flexible disk drive specifications.

1-12. POWER ON FUNCTIONAL DESCRIPTION

When AC power is applied, AC power is routed through 10 AMP line filter (FL1) to one side of the circuit breaker switch. When the circuit breaker switch is placed in the ON position, filtered AC from FL1 is routed through the switch contacts through terminal board TBl. This filtered AC is then routed to the power supply filters and to the spindle motor of the flexible disk drive. With AC power supplied to the power supply, it initiates a DC power up sequence.

During this power up sequence, a memory protect signal prevents the processor from starting program execution until all DC voltages are within their rated limits.

While the DC power is sequenced up, the circuit breaker switch lamp is lit. Should the lamp begin to flicker or fail to light, it indicates a power supply problem. This could be for any of the following reasons:

- o current overload - Too much power is drawn from the power supply or a short circuit exists.
- o voltage failure - Either the regulator failed or a short circuit exists between DC voltage lines.
- o Temperature Overload - One or more of the fans quit functioning resulting in a temperature increase that exceeds 70 degrees F.
- o Primary Power - Either a short circuit of the AC lines exists or excessive current is being drawn causing the circuit breaker portion of the switch to trip.

Once power has been sequenced up, should power fail for any of the reasons listed, signal PFIN is generated which is routed to the non-maskable interrupt input of the CPU (8086) on the processor board.

The power supply sequencing signals and front panel control signals are routed via the backplane wiring through connector P2 to the processor. These signals are:

- o PFIN/ is the power fail interrupt signal from the power supply that goes active (negative true low) 8ms after a power fail event occurs.

GENERAL INFORMATION

- o MPRO/ is the memory protect signal from the power supply that goes active at least 8ms after signal PFIN goes active. Upon initial power application, this signal is active until after all voltages are within their rated limits.
- o RTC is the real time clock from the power supply. It is a periodic square wave whose frequency is synchronized with the AC line at twice the line frequency.
- o AUX RESET/ is the de-bounced state of the front panel RESET switch.
- o HLT/ is a signal from the processor that indicates that the CPU is halted.
- o WAIT/ is a signal from the processor indicating that the CPU is in a wait state.
- o ALE/ is a signal from the processor indicating that an address is present on the internal bus of the processor board.

Upon this initial power up sequence (or whenever the RESET switch on the front panel is pressed), the system is initialized forcing the CPU on the processor board to access its on-board ROM at address location FFFFF where the start of the System Confidence Test (SCT) diagnostic software program resides.

The SCT is a diagnostic program that checks the ability of the processor board to communicate with:

- o on-board I/O programmable ports
- o on-board ROM
- o on-board RAM
- o off-board RAM
- o disk controller
- o Winchester drive
- o Flexible disk drive
- o Numeric Data Processor

The CPU communicates with its on-board programmable I/O ports, under software control, through a sequence of I/O read and write commands. Table 1-1 lists the I/O port addresses used to control the various programmable functions.

GENERAL INFORMATION

Table 1-1. On-Board I/O Port Address Assignments

I/O Address*	Chip Select	Function
00C0 or 00C4	8259A PIC	Write: ICW1, OCW2, and OCW3 Read: Status and Poll
00C2 or 00C6		Write: ICW2, ICW3, ICW4, OCW1 (Mask) Read: OCW1 (Mask)
00C8	8255A PPI	Write: Port A (J1) Read: Port A (J1)
00CA		Write: Port B (J1) Read: Port B (J1)
00CC		Write: Port C (J1) Read: Port C (J1) or Status
00CE		Write: Control Read: None
00D0	8253 PIT	Write: Counter 0 (Load Count ÷ N) Read: Counter 0
00D2		Write: Counter 1 (Load Count ÷ N) Read: Counter 1
00D4		Write: Counter 2 (Load Count ÷ N) Read: Counter 2
00D6		Write: Control Read: None
00D8 or 00DC	8251A USART	Write: Data (J2) Read: Data (J2)
00DA or 00DE		Write: Mode or Command Read: Status
*Oddaddresses (i.e., 00C1, 00C3, . . . 00DD) are illegal.		

GENERAL INFORMATION

Figure 1-3 shows the SCT test sequence. Refer to paragraph 3-9 for an explanation of the SCT routines.

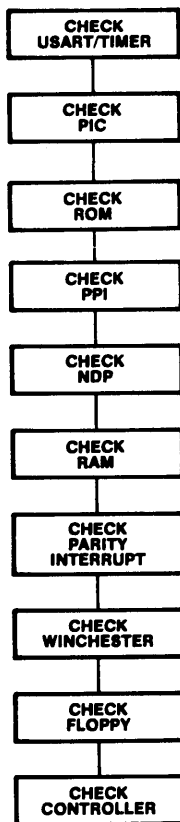

Figure 1-3. SCT Test Sequence

GENERAL INFORMATION

Upon successful completion of the SCT, control is passed to the bootstrap loader to boot the iRMX 86 Operating System from the Winchester disk. If a Winchester error is encountered (either an unformatted disk or formatted without the operating system), the system halts and the HALT light is lit. When this condition occurs (typically, at initial installation), rerun the SCT and bootstrap load the iRMX 86 Operating system contained in the file residing on the Installation Diskette installed in the flexible disk drive. Refer to paragraph 2-10. If any other NO-GO condition was encountered, the SCT exits to the 957B monitor. Refer to Table 4-2 for troubleshooting information.

Figure 1-4 shows the physical system address allocations.

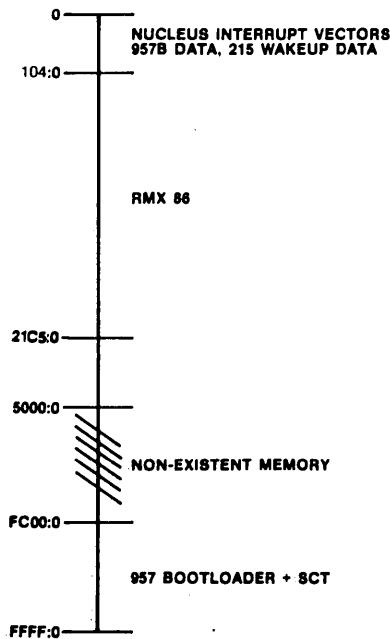

Figure 1-4. System 86/330 Physical Address Allocations

GENERAL INFORMATION

1-13. SPECIFICATIONS

Table 1-2 lists the System 86/330 specifications. Table 1-3 lists the Winchester Drive specifications. Table 1-4 lists the Flexible disk drive specifications. Table 1-5 lists the power supply specifications.

Table 1-2. System 86/330 Specifications

WORD SIZE	
Instruction:	8,16, or 32 bits
Data	8/16 bits
INSTRUCTION CYCLE TIME:	400 nanoseconds for fastest executable instructions (assuming instruction is in the queue). 1.0 microseconds for fastest executable instructions (assuming instruction is not in the queue).
MEMORY CAPACITY:	
RAM	The base system is shipped with 320K bytes which can be expanded with other Intel RAM memory boards up to 1M bytes. On board address range 00000 to 0FFFF. Off board address range 10000 through 4FFFF.
ROM	16K bytes. Address range FC000 through FFFFF.
INTERRUPTS:	Eight level, maskable, nested priority interrupt network and 1 non-maskable interrupt.
INTERFACE	EIA Standard RS232C signals provided and supported.
Serial:	9600 Baud (asynchronous) or 150 to 19.2K baud (synchronous); programmable baud rates and serial formats.
Parallel:	A parallel I/O port configured to interface with an industry standard Centronix compatible interface printer.
AC REQUIREMENTS:	6.5A @ 88 to 126VAC, 60Hz <u>+5%</u> , single-phase 3.25A @ 176 to 252VAC, 50Hz <u>+5%</u> , single-phase Maximum total power consumption 821W.

GENERAL INFORMATION

Table 1-2. System 86/330 Specification (continued)

ENVIRONMENTAL REQUIREMENTS:	
Operating:	
Temperature:	15° C to 35 C° 26° C Maximum wet bulb
Relative Humidity:	20% to 80% non-condensing over the operating temperature range.*
Altitude:	Sea level to 6000 feet.
Vibration & shock:	0.0014" PTP 5 to 25Hz 0.007" PTP 25 to 55Hz 0.3g 0 to peak 55 to 300Hz 1.0g shock for 10 to 11ms duration
Non-Operating:	
Temperature:	-25° C to 60° C
Relative Humidity:	20% to 80% non-condensing.
Altitude:	Sea level to 12000 feet.
Vibration & shock:	0.008" PTP 5 to 25Hz 0.004" PTP 25 to 55Hz 2.0g 0 to peak 55 to 300Hz 15.0g shock for 10 to 11ms duration
Shipping:	15.0g shock for 10 to 11ms duration
PHYSICAL CHARACTERISTICS:	
Width:	16.75 in. (42.55 cm)
Height:	12.25 in. (31.12 cm)
Depth:	21.00 in. (53.34 cm)
Weight:	75 pounds (34.02 kg)
*Note: The environmental combination of humidity and temperature together cannot exceed 26 C wet bulb.	

Table 1-3. Winchester Drive Specifications

Recording Density:	6670 bpi
Track Density:	480 tpi
Cylinders:	526
R/W heads:	5
Bytes/sector:	1024
Sectors/track:	12
Bytes/track:	13.4K
Rotational speed:	3600RPM
Avg. latency:	8.34 ms

GENERAL INFORMATION

Table 1-3. Winchester Drive Specifications (continued)

Transfer rate:	6.44 mbits/sec.
Head settling time:	8 ms
ACCESS TIMES:	
Track-to-track:	10 ms
Avg.:	45 ms
Max.:	90 ms
Motor/on time:	30 sec
Soft error rate:	1×10^{10}
Hard error rate:	1×10^{13}
Seek error rate:	1×10^6

Table 1-4. Flexible Disk Drive Specifications

Capacity per side:	800K bytes (unformatted) 500K bytes (IBM format - 26 sectors)
Recording Density:	6816 bpi
Track Density:	48 tpi
Number of tracks:	77/side
Number of heads:	2
Recording method:	FM or MFM
Transfer rate:	250K bits/sec
Rotational speed:	360 RPM
Rotational latency:	83ms (AVG)
Access time:	
Track-to-track:	3ms
AVG:	91ms
Head settling:	15ms
Head load:	35ms
Motor start:	2 sec.
ERROR RATES:	
Soft:	1 in 10^9 bits read
Hard:	1 in 10^{12} bits read
Seek:	1 in 10^6 seeks

The diskette is formatted such that track 0 on head 0 is recorded using single density, 26 sectors of 128 bytes each. All other tracks are recorded with either single or double density recording method using 4 or 8 sectors of 1024 bytes each.

GENERAL INFORMATION

Table 1-5. Power Supply Specifications

Component	+5V	+12V	-5V	-12V	+24V	-24V
Processor	5.875A	0.35A		0.04A		
Win.(215)	3.25A		0.15A			
Flex.(218)	0.9A					
RAM (056)	5.5A					
Flex. drive	1.0A		0.05A		0.6A	
Win. drive	2.5A		1.5A	0.4A	3.5A	
Total	19.025A	0.35A	1.7A	0.44A	4.1A	
Available for options	11.025A	1.5A	0.3A	1.5A	3.7A	1.6A

Regulation: +4%

Ripple +5V: 50mV p-p
+12V: 50mV p-p
+24V: 100mV p-p

CHAPTER 2. INSTALLATION

2-1. INTRODUCTION

This chapter provides information for incoming inspection and installation considerations and also provides instructions for unpacking, and installing the System 86/330 and unlocking the Winchester drive shipping restraint. Instructions for rack mounting the System 86/331 are provided. Software installation instructions are also provided.

2-2. INCOMING INSPECTION

Inspect the exterior of the shipping carton immediately upon receipt for evidence of mishandling during transit. If the shipping carton is either severely damaged or waterstained, request that the carrier's agent be present when the carton is opened. If the carrier's agent is not present, and the contents of the carton are damaged, keep the carton and packing material for the agent's inspection.

For repairs to a product damaged during shipment, contact the Intel Technical Service Center to obtain a Return Authorization Number and further instructions. (Refer to Chapter 5.) A purchase order will be required to complete the repair. A copy of the purchase order should be submitted to the carrier with your claim.

It is suggested that salvageable shipping cartons and packing material be saved for future use in the event the product must be shipped or returned for service.

2-3. INSTALLATION CONSIDERATIONS

The physical characteristics (width, height, depth, and weight) of the System 86/330 are given in Table 1-3. Ensure that the work area (bench, table, desk, or other structure) will accommodate and support the combined weight of the basic system and required components.

Chassis cooling is provided by fans mounted in the power supply enclosure. The chassis cooling system is designed to draw ambient room air in through openings at the bottom of the front panel. The air passes by the peripheral devices and down through holes in the top of the power supply, through the power supply and out the back of the chassis.

All chassis panels must remain in place for optimum air circulation. To ensure proper cooling, the openings in front of the unit and in the back of the unit should not be obstructed. A space of at least three inches should be maintained between the chassis and any wall or other obstruction.

INSTALLATION

The power cord for the system plugs into a three-conductor power outlet. The round pin on the power cord is safety power ground. If your facility does not have three-connector power outlets, do not defeat the safety ground by using three-prong to two-prong adapters. Have a qualified electrician rewire the system power outlets to accommodate the third wire.

As with most sensitive electronic equipment, the System 86/330 is not totally immune to its environment. To minimize performance degradation:

- a. Maintain the temperature and humidity environment in accordance with the specifications listed in Table 1-3.
- b. Use antistatic mats in the work area.

If these precautionary steps are taken and you experience problems, you can obtain service and repair assistance from Intel as directed in Chapter 5.

2-4. UNPACKING

The System 86/330 is packaged in a specially designed shipping carton, as shown in Figure 2-1, for protection against damage during shipment. To remove the System 86/330 from its shipping carton, proceed as follows:

1. Cut the retaining strap.
2. Unfold the carton at the bottom and remove the top portion of the carton.
3. Remove the accessory carton.
4. Remove the end caps protecting the unit.

CAUTION

Use recommended lifting techniques.
System 86/330 weighs in excess of 75
pounds.

5. Lift the unit from shipping carton.

INSTALLATION

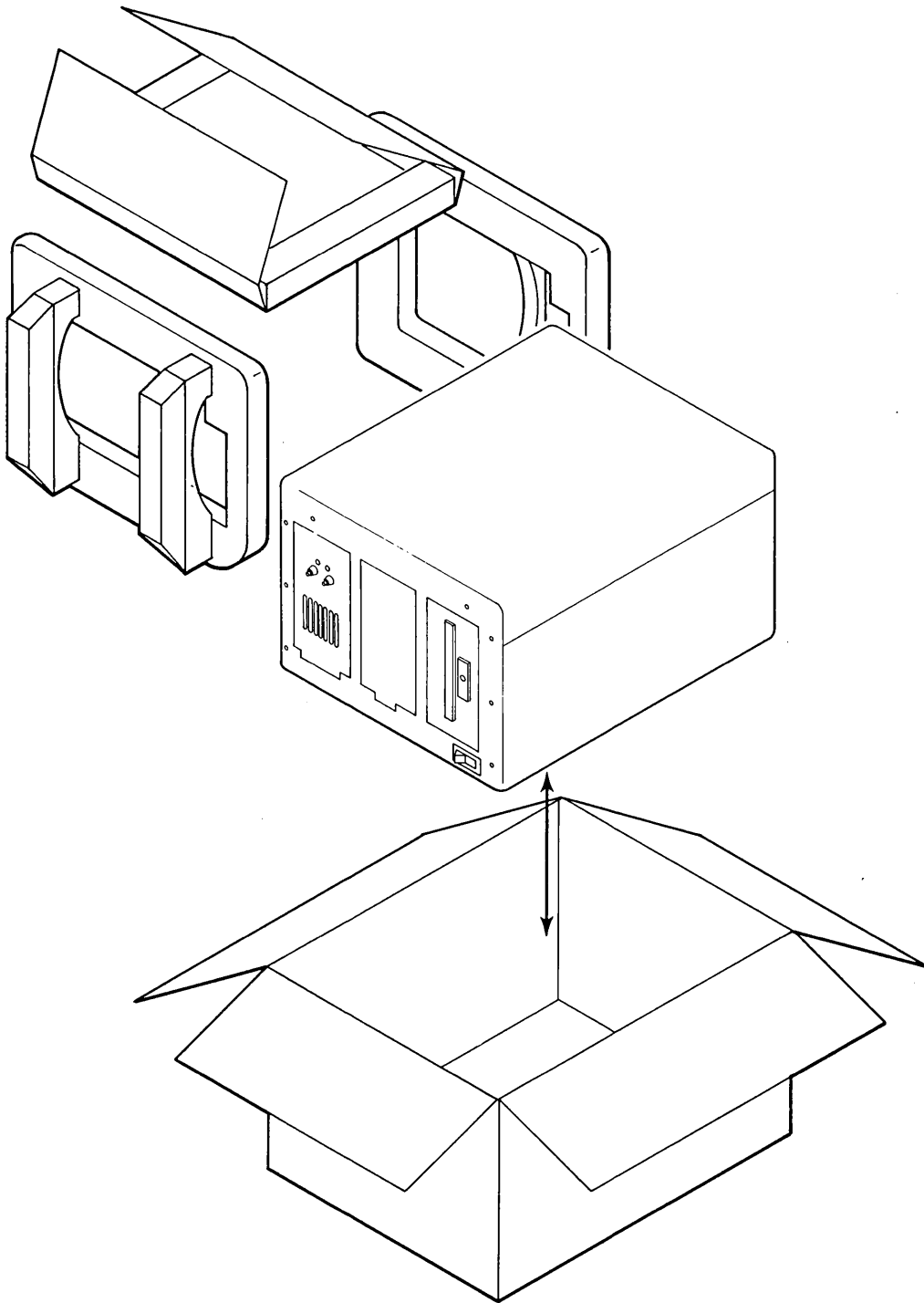

Figure 2-1. Unpacking

INSTALLATION

2-5. INSTALLATION PROCEDURE

Your System 86/330 is designed for simplicity of installation. The following procedure is primarily for an initial installation. To install the system, proceed as follows:

1. Unpack System 86/330. (Refer to paragraph 2-4.)
2. Position the system at the installation site. (The system is designed to be installed on top of a desk or to be installed in a standard RETMA rack. If the unit is to be installed on a desk top, refer to paragraph 2-3 for installation considerations. If the unit is to be rack mounted, refer to paragraph 2-6.)
3. Remove the top cover of the unit and ensure that all connectors and boards are firmly seated.
4. Interconnect the RS232 serial I/O cable between connector J1 (located on the rear panel) and the user supplied CRT/Keyboard terminal. (If the cable is not available, it needs to be fabricated. Refer to paragraph 2-8.)

(If a Centronics printer is to be connected, refer to paragraph 2-9.)

5. Position the Winchester shipping restraint to the UNLOCKED position. (Refer to paragraph 2-7.)
6. Remove flexible disk drive cardboard door restraint and cardboard diskette.
7. If an optional Winchester drive is to be added, install the optional Winchester daisy chain drive in accordance with the procedure in Appendix A.
8. If an optional flexible drive is to be added, install the optional daisy chain flexible disk drive in accordance with the procedure in Appendix B.
9. Interconnect the power cord between the back of the chassis and the power source.

2-6. RACK MOUNTING

Purchase the hardware required to install System 86/331 into a standard RETMA 19-inch wide rack. The chassis is designed for the attachment of the slides, see Figures 2-2 and 2-3.

To install the chassis into a rack enclosure, proceed as follows:

NOTE

This procedure requires two persons.

INSTALLATION

To install the chassis into a rack enclosure, proceed as follows:

NOTE

This procedure requires two persons.

1. Remove front panel from chassis. (Refer to paragraph 4-6.)
2. Install slides on each side of the chassis as shown in Figure 2-3. Then install the slide mount brackets within the RETMA rack.
3. Using two persons, lift the chassis into the rack enclosure and position at the desired height.
4. Reinstall the front panel and proceed with step 3 of paragraph 2-5.

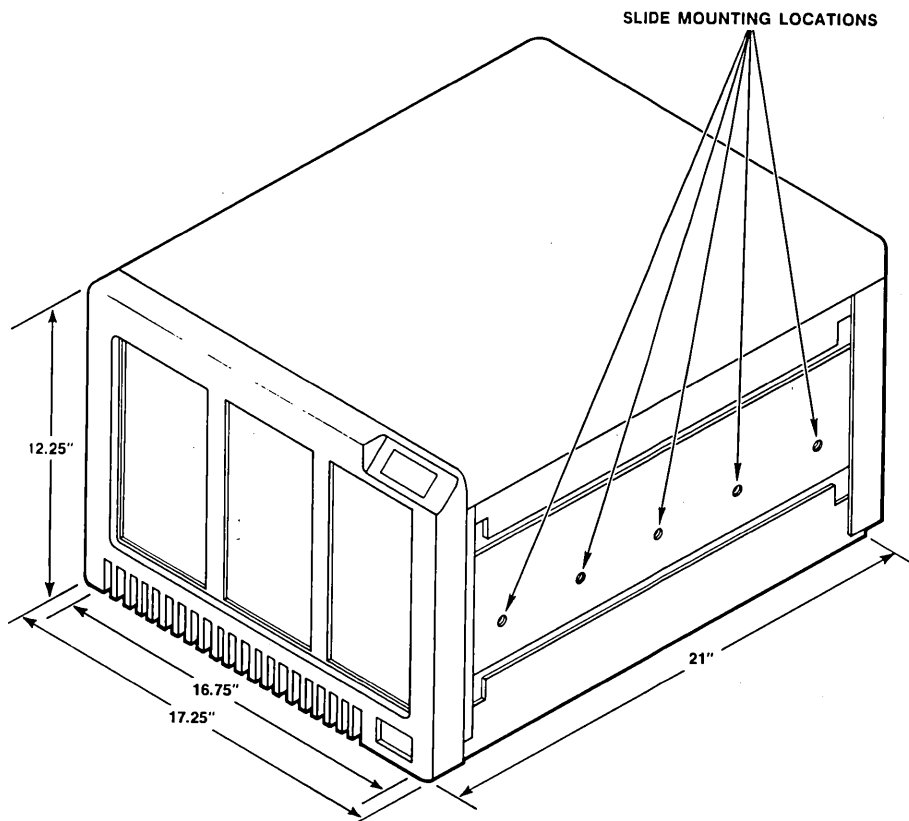

Figure 2-2. System 86/330 Slide Mounting Location

INSTALLATION

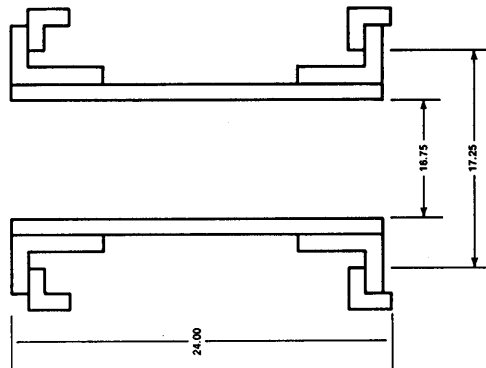

Figure 2-3. Typical Slide Mounting Inside Cabinet

2-7. INSTRUCTIONS FOR UNLOCKING WINCHESTER SHIPPING RESTRAINT

During shipment, the Winchester shipping restraint is in the locked position to prevent damage to the head/media. Before applying power to the System 86/330, ensure that it is repositioned to the unlocked position. To unlock the Winchester shipping restraint, proceed as follows:

CAUTION

Unlock Winchester shipping restraint before applying power. Failure to comply may cause damage to drive components.

1. Remove the front panel assembly by pulling out on the front panel bezel. (Refer to paragraph 4-6.)
2. Remove the top cover. (Refer to paragraph 4-7.)
3. Remove two screws securing the filler panel to the chassis and remove the filler panel. (Refer to Figure 2-4.)
4. Position the lever slightly to the left and then up and into the UNLOCK position.
5. Re-install the filler panel and bezel assemblies.

INSTALLATION

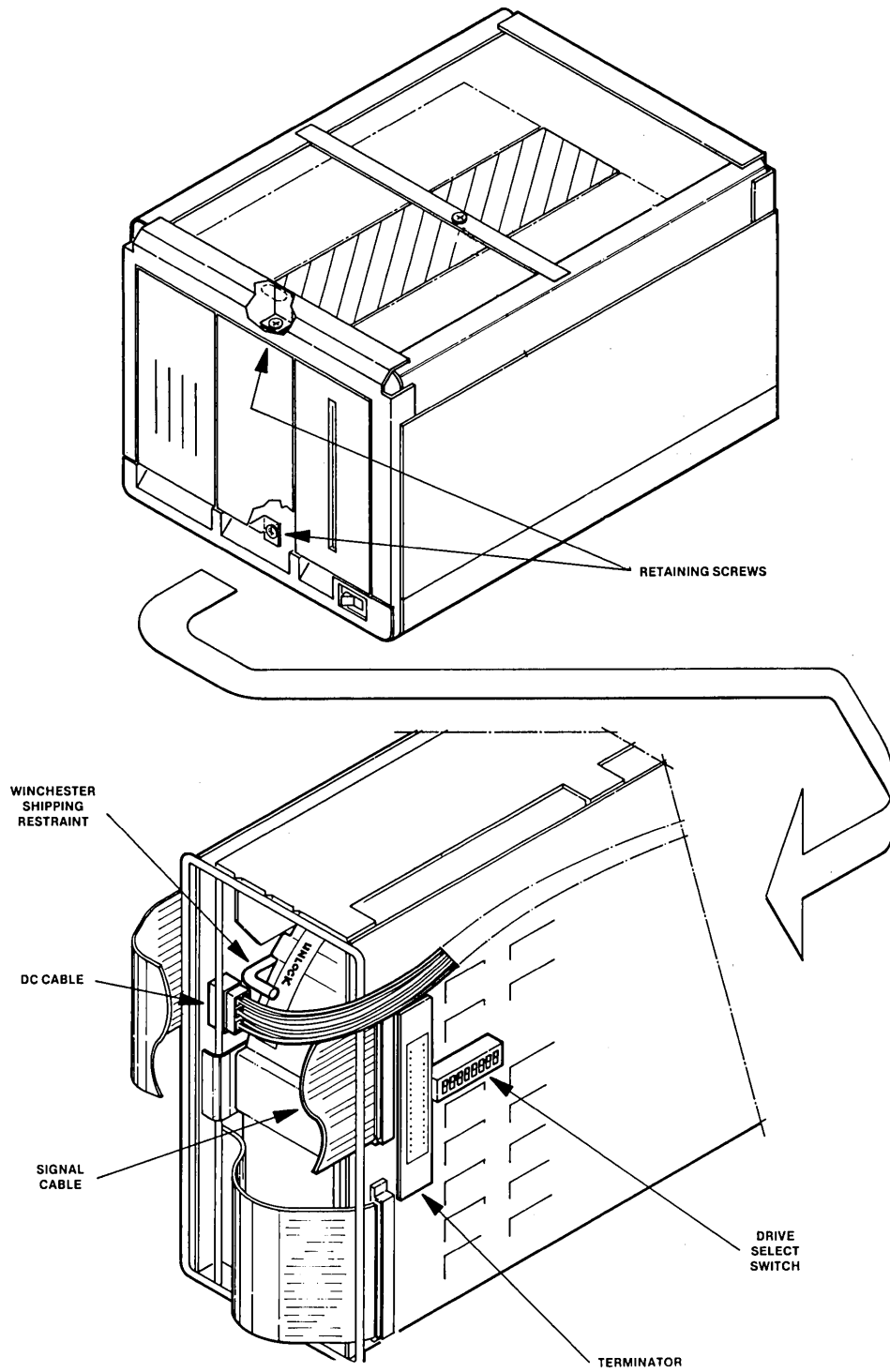

Figure 2-4. Winchester Shipping Restraints

INSTALLATION

2-8. SERIAL I/O CABLE FABRICATION DATA

The pin assignments for connector J1 are listed in Table 2-1.

Table 2-1. Serial I/O Cable Fabrication Data

PIN NUMBER	FUNCTION
1	Frame ground
2	Transmit Data (TXD)
3	Receive Data (RXD)
4	Request To Send (RTS)
5	Clear To Send (CTS)
6	Data Set Ready (DSR)
7	Ground
8	N/C
9	N/C
10	+5V DC
11	+12V DC
12	N/C
13	Sec CTS
14	N/C
15	N/C
16	Sec Rec Signal
17	Rec Sig Ele Timing (RXC)
18	N/C
19	N/C
20	Data Terminal Ready (DTR)
21	N/C
22	N/C
23	-12V DC
24	Transmit signal
25	+5V DC

INSTALLATION

2-9. PARALLEL I/O CABLE FABRICATION

The pin assignments for connector J2 are listed in Table 2-2.

Table 2-2. Parallel I/O Cable Fabrication Data

PIN. NUMBER	FUNCTION
1	N/C
3	N/C
5	N/C
7	N/C
9	N/C
11	N/C
13	N/C
15	N/C
17	N/C
19	N/C
21	N/C
23	Character Strobe
25	Printer Ready (ON LINE)
27	Printer Ready (Paper Error)
29	Character Acknowledge
31	N/C
33	Data bit 7
35	Data bit 6
37	Data bit 5
49	Data bit 4
41	Data bit 3
43	Data bit 2
45	Data bit 1
47	Data bit 0
49	N/C

All even pin numbers are tied to ground as logic ground returns.

INSTALLATION

2-10. SOFTWARE INSTALLATION

Because the Winchester disk is formatted without the iRMX Operating System files prior to being shipped, software installation consists of bootstrap loading the iRMX 86 Operating System from the flexible disk drive with the Installation Diskette inserted, formatting the Winchester disk and copying the iRMX 86 Operating System onto the Winchester disk.

Software installation is performed:

1. upon initial receipt of the System 86/330
2. to copy the latest version of the iRMX 86 Operating System
3. after replacement of the Winchester drive

To install the iRMX 86 Operating System, proceed as follows:

1. Turn the AC power switch to ON and insert the Installation Diskette into the flexible disk drive. (After a delay of about 5 seconds, a series of asterisks are displayed on the CRT.)
2. At the keyboard, enter:
Shift U (Press SHIFT and U keys together.) This invokes a baud rate search and resumes the SCT diagnostics.
3. When the CRT displays the prompt (.) during the PIC test, press the (i) key. (No c/r - where c/r is the RETURN key.)
4. After the SCT test sequence completes (the booting RMX message appears), press the RESET pushbutton on the front panel. This restarts the SCT testing sequence.
5. At the keyboard, enter:
Shift U
6. When the CRT displays the prompt during the PIC test, press the INTRPT pushbutton on the front panel.
7. At the keyboard, enter:
b :wf0: c/r (no space between the colon and the c/r key) (This boots the iRMX 86 Operating System from the flexible disk drive.)

About 5 minutes later, the CRT displays the following:

```
SYSTEM 86/330 V1.0 USER = WORLD
```

```
-DATE  
DATE:01 JAN 78  
-TIME  
TIME: 00 00 00  
-END SUBMIT LOGIN
```

```
-;To install the system on the Winchester, type:  
;  
-;SUBMIT INSTALL.CSD  
-;END SUBMIT LOGIN
```

INSTALLATION

9. At the keyboard, enter:

```
submit install.csd c/r
```

(This submits the file to format the Winchester disk and copy the iRMX 86 Operating System onto the Winchester disk.)

10. Wait until the dash prompt occurs, then press the INTRPT pushbutton on the front panel.
11. Enter:
b c/r (This boots the iRMX Operating System from the Winchester.)
12. Human Interface displays prompt (-). (The system is now ready for program development.)
13. For a list of all files on the disk, enter any of the following:
DIR c/r (displays USER directory)
DIR/SYSTEM (displays SYSTEM directory)
DIR/LANG (displays LANG directory)
DIR (displays SYSTEM directory)

CHAPTER 3. OPERATION

3-1. INTRODUCTION

This chapter provides information concerned with the controls and indicators and the basic operating instructions for System 86/330.

3-2. AC POWER ON/OFF SWITCH

THE AC power ON/OFF switch is an illuminated rocker type switch with a built in 10 AMP circuit breaker located at the lower right side of the chassis. When the switch is set to the ON position, filtered AC from line filter 1 is routed from its input terminals, through its output terminals through filter 2 to the input of the power supply. The power supply initiates a power up sequence. Figure 3-1 shows the power on sequence. When the +5V DC is sequenced up, the lamp within the switch is lighted.

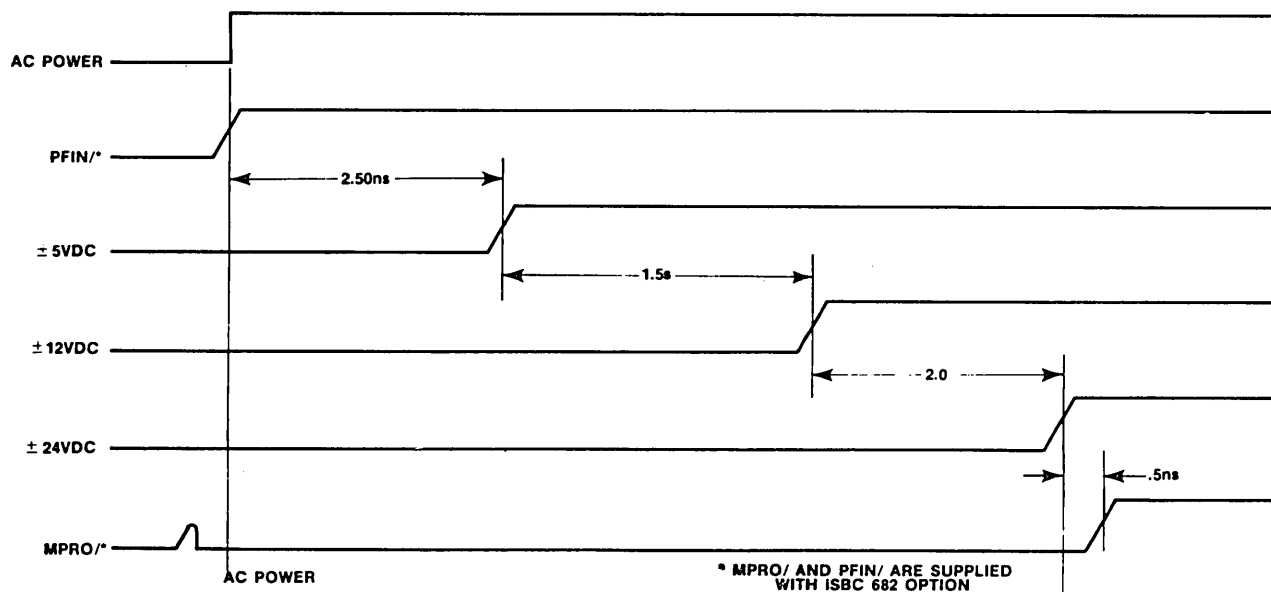

Figure 3-1. System 86/330 Power on Sequence

OPERATION

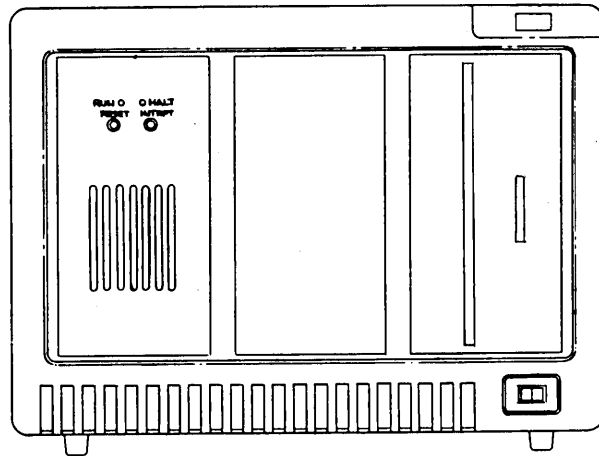

Figure 3-2. System 86/330 Controls and Indicators

3-3. FRONT PANEL CONTROLS AND INDICATORS

Figure 3-2 shows the location of the front panel controls and indicators.

3-4. RESET SWITCH

The RESET switch is a pushbutton switch wired to P2 pin 38 on the processor board. It forces the processor to execute the reset (initialize) routine.

3-5. RUN INDICATOR

The RUN indicator is a system's status indicator. It is lit when the CPU is executing an instruction. It is extinguished after a HALT instruction is executed or during a power on sequence. When an error concerned with the processor's USART is detected, the RUN indicator flashes on and off inconjunction with the HALT indicator.

3-5. HALT INDICATOR

The HALT indicator is a system's status indicator. It is lit after a HALT instruction is executed and during a power on sequence. It is extinguished when the CPU is executing an instruction. When an error concerned with the processor's USART is detected, the HALT indicator flashes on and off inconjunction with the RUN indicator.

OPERATION

3-6. INTRPT SWITCH

The INTRPT (interrupt) switch is a pushbutton switch wired to provide an interrupt level 1. It forces the processor board to execute an interrupt service routine.

3-7. SYSTEM INITIALIZATION

Upon initial power up or as a result of pressing the front panel RESET switch pushbutton, the System Confidence Test (SCT) is executed.

To invoke the System Confidence test, proceed as follows:

1. With the user supplied terminal powered on, turn System 86/330 AC power switch to ON. (After about 5 seconds delay, the CRT displays a series of asterisks.)
2. Enter:
Shift U. (This invokes the baud rate search and the SCT.)
3. The PIC test prompts for a character input.
4. Enter:
i
5. The progress and results of the SCT are displayed, see Figure 3-3.

After completion of the SCT, the bootstrap loader loads the iRMX 86 Operating System from the Winchester assuming that the SCT test results are "GO" and that the Operating System file resides on the Winchester.

3-8. SYSTEM CONFIDENCE TEST (SCT)

The SCT provides a coarse level of diagnostics that determine if major components of the System 86/330 are operational. It is passed control upon system initialization or reset.

The SCT resides in ROM on the iSBC 86/12A board and is co-resident with the iRMX 86 Bootstrap Loader and the 957B monitor. It interfaces with other software only upon termination, passing control to the Bootstrap Loader if no errors were encountered. If any error other than a Winchester error was found, control is passed to the 957B monitor.

The progress of each routine within a specific test is indicated by either a dot (period) which indicates successful completion or a question mark (?) which indicates that an error occurred. Figure 3-3 depicts a successfully completed SCT test. Table 4-2 defines an abnormal test result related to the question mark's position within the CRT display. It also lists the error encountered and the probable failing subassembly. There are ten tests.

OPERATION

If these tests terminate normally, control is transferred to the iRMX 86 Bootstrap Loader. Should an error be detected, a message is issued to the resident serial I/O channel of the iSBC 86/12A board and control is transferred to the 957B monitor at completion of the test.

SCT330, V1.0		
TEST		STATUS
USART/TIMER		GO
PIC	.*	GO
ROMCKSM	.	GO
SPINNING UP	>>>	
PPI	...	GO
NDP	.	GO
RAM TEST	TOTAL MEMORY = nnnnK	
ON BOARD		GO
OFF BOARD		GO
EXTENDED		GO
PARITY INT		GO
WINCHESTER		GO
FLOPPY		GO
CONTRLR		GO
SCT SUCCESSFUL...NOW BOOTING iRMX86		
nnnnK = decimal number of K bytes found in the system.		

Figure 3-3. Successfully Completed SCT Test Results

TEST 1. USART/TIMER

This test checks the processor's ability to communicate with its on-board USART and thus establish a communication path via the RS232 serial I/O port to the user installed CRT/keyboard.

The USART/TIMER test routine initializes the 8251 USART and the 8253 Programmable Interval Timer (PIT) on the iSBC 86/12A board. The status word from the USART is validated. If the status word is valid, a message "GO" is printed out on the attached CRT. If the status word is invalid, the HALT and RUN lights on the front panel will flash indicating that the iSBC 86/12A board is defective.

With communication established with the USART, the attached CRT is able to display the SCT results.

OPERATION

TEST 2. PIC INITIALIZATION

The second test checks the ability of the Programmable Interrupt Controller (PIC) on the processor board to generate the appropriate interrupt levels. Table 3-1 lists the various interrupt level assignments and Table 3-2 lists the interrupt vector address locations.

Table 3-1. Interrupt Assignments

Level	Description	Priority
NMI	Power fail interrupt	8 (Highest)
IR0	Floating point exception	7
IR1	Multibus interrupt 1 console	6
IR2	On board timer	5
IR3	Available to the user	4
IR4	Line Printer	3
IR5	Multibus interrupt 5 - disk	2
IR6	Serial I/O Receive	1
IR7	Serial I/O Transmit	0

Table 3-2. Interrupt Vector Addresses

Interrupt	Monitor	IRMX 86
NMI	00008	00008
0	00080	000E0
1	00084	000E4
2	00088	000E8
3	0008C	000EC
4	00090	000F0
5	00094	000F4
6	00098	000F8
7	0009C	000FC

This routine initializes the PIC 8259 . No tests are performed on this device. This test awaits an input from the user. If no input is received, a NO-GO message is generated after a time-out period. Any character may be entered except a D.

OPERATION

TEST 3. ROM CHECKSUM

This routine verifies that the address and data lines of the on-board ROM are intact. The on-board ROM address space spans address locations FC000 through FFFFF.

This routine accesses all ROM locations and calculates a checksum of their contents. The calculated checksum is compared with the recorded checksum stored in ROM. If the contents compare, a "GO" message appears on the CRT. If the values do not match, the "NO-GO" message appears.

The SCT starts the spindle motor of the Winchester drive rotating. This is done at this point within the program to allow time for the spindle motor to achieve rated spin speed before the Winchester test routine is invoked.

TEST 4. PPI INITIALIZATION

This routine checks the processor's ability to communicate with its on-board Programmable Peripheral Interface (PPI). It checks all three ports of the PPI.

The PPI 8255 is initialized and its status word is compared. If the status word is correct, the message "GO" appears. If the status word is invalid, the message "NO-GO" appears.

TEST 5. NDP

This routine checks the processor's ability to communicate with the iSBC 337 Numeric Data Processor. It writes a word to the numeric data processor (NDP) and compares the word read back.

TEST 6. RAM TEST

This routine checks the ability of the processor to communicate with RAM. The dual port RAM address space spans address locations 00000 through OFFFF. The off-board RAM address space spans address locations 10000 through 4FFFF.

If no errors are detected, a "GO" message appears on the CRT. If an error is detected, a "NO-GO" message appears.

OPERATION

TEST 7. PARITY INT

This routine verifies that the RAM memory board can detect a parity error and generate the appropriate response. It writes a test value to a RAM location while the memory parity controller is set to one format, reinitializes the controller to the opposite format, and attempts to read the original value. This should generate a parity error which causes the message "GO" to appear on the CRT. If no parity error occurs, the message "NO-GO" appears on the CRT.

TEST 8. WINCHESTER

This routine verifies that the processor can communicate with the disk controller. The processor communicates with the disk controller via four control blocks (linked lists) located in memory on the RAM memory board. The processor issues a series of instructions to the I/O Wake-up address of the disk controller.

This routine initializes the iSBC 215 Winchester controller and invokes the controller micro-diagnostics. These two functions will also cause the controller's ROM and RAM to be tested. After each function, the status word from the controller is examined. If valid status words are received, the message "GO" appears. If the status words are invalid, the message "NO-GO" appears.

TEST 9. FLEXIBLE DISK

This routine checks the iSBX 218 controller and is identical with that of the Winchester tests except for device numbers. If an error is detected, the message NO-GO will appear on the CRT. An unformatted diskette or a diskette with an invalid format causes a NO-GO message to appear. If no errors are encountered, the message GO will appear. If a diskette is not present, a NOT READY message will appear. This message is still construed to be a GO type message. If the flexible disk drive is not connected (off line), a NOT READY message appears.

TEST 10. CONTRLR INT

This test verifies that the disk controller can generate an interrupt. If an interrupt is not received, the message "NO-GO" appears on the CRT. If no errors are encountered, the message "GO" appears.

CHAPTER 4. MAINTENANCE

4-1. INTRODUCTION

This chapter provides preventive maintenance, troubleshooting, and removal and replacement procedures.

4-2. PREVENTIVE MAINTENANCE

The prime objective of any preventive maintenance activity is to provide maximum machine availability to the user. Every preventive maintenance operation should assist in realizing this objective.

Visually inspect for evidence of corrosion, dirt, wear, binds, and loose connections. Noticing these items during preventive maintenance may save downtime later. Table 4-1 lists the preventive maintenance schedule.

Table 4-1. Preventive Maintenance Schedule

Recommended Interval	Operation
12 months	Inspect flexible disk drive belt for frayed or weakened areas. Replace, if necessary.
12 months	Inspect flexible disk drive actuator band, capstan and shaft for excessive oil and dirt. Clean only if necessary.
12 months	Clean read/write heads only if necessary using Innovative Computer Products cleaning diskette (P/N 2024).

4-3. TROUBLESHOOTING

Troubleshooting is the systematic isolation of an abnormal condition or symptom down to a defective replaceable sub-assembly. If an abnormal symptom occurs during the initial power up sequence, refer to Figure 4-1. Figure 4-1 is a logical troubleshooting guide that is meant as an aid for isolating a problem occurring as a result of an initial power up sequence.

If a NO-GO message is displayed as a result of the SCT, refer to Table 4-2. Table 4-2 presents all abnormal SCT test results and lists the probable failing sub-assembly.

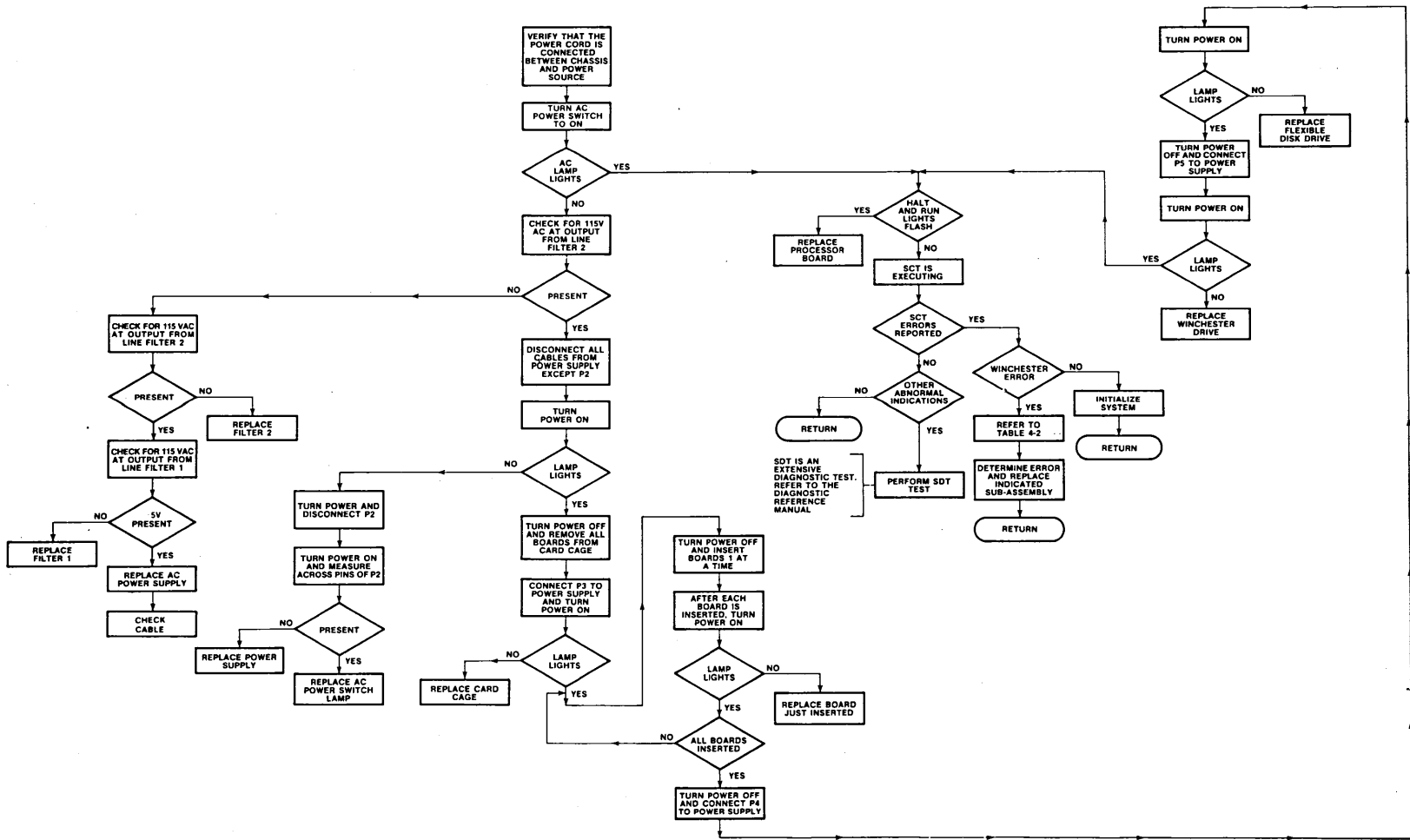

Figure 4-1. System 86/330 Troubleshooting Guide

MAINTENANCE

Table 4-2. Abnormal SCT Test Results

TEST	1 2 3 4	MEANING	CORRECTIVE ACTION
USART		If GO is not displayed the halt and run lights flash	Replace Processor Board Defective USART 8251A
PIC	? ?	TMRO INT did not occur Transmit INT did not occur	Replace Processor Board Replace Processor Board
ROMCKSM	?	Checksum variation	Replace Processor Board
SPINUP	NOT A TEST		
PPI	? ? ?	Port A Port B Port C	Replace Processor Board Replace Processor Board Replace Processor Board
NDP	?	337 Did not respond	Replace Processor Board
RAM TEST ONBOARD OFFBOARD EXTENDED			Replace Processor Board Replace iSBC 056 Board Replace user added memory Board
PARITY	?	Parity Error on MB02	Replace iSBC 056 Board
WINCHESTER	? ?	Winchester Disk is not formatted iSBC 215 Diagnostic Reported an error	Reformat disk Replace Disk Controller Board or Winchester Drive *
FLOPPY	?	Not Ready--Door Opened or Unformatted Diskette	Insert Diskette, Close Door Hit Reset Insert Formatted Diskette
CONTRLR INT	?	Floppy Diskette is not formatted or Interrupt from iSBC 215 did not occur.	Replace Disk Controller Board or Flexible Disk Drive *

* If more diagnostic information is needed, invoke the System Diagnostic Test (SCT). Refer to the System 86/300 Series Diagnostic Reference Manual (Order Number 143896).

MAINTENANCE

When a NO-GO message is displayed, determine the probable failing sub-assembly as indicated in Table 4-2. Replace the defective sub-assembly in accordance with the removal and replacement procedure listed for that sub-assembly. Then, invoke the SCT again and verify proper operation.

Perform the preliminary checks to eliminate apparent malfunctions and ensure that the unit is properly connected to an adequately rated power source.

4-4. PRELIMINARY CHECKS

1. Remove the top cover in accordance with paragraph 4-7.
2. Visually inspect the interior for evidence of:
 - a. broken or loose terminals - tighten or repair.
 - b. improper seating of boards - install boards properly.
 - c. improper seating of connectors - install connectors properly.

4-5. REMOVAL AND REPLACEMENT PROCEDURES

Removal and replacement procedures of individual sub-assemblies should be performed when indicated within the troubleshooting guide as a corrective action. Read the complete procedure before doing it.

4-6. Front Panel Removal and Replacement Procedure

The front panel assembly is removed to gain access to the filler panel, the Winchester drive, and the flexible disk drive. To remove the front panel, pull out on the front panel assembly. The front panel is attached by four ball stud fasteners, see Figure 4-2.

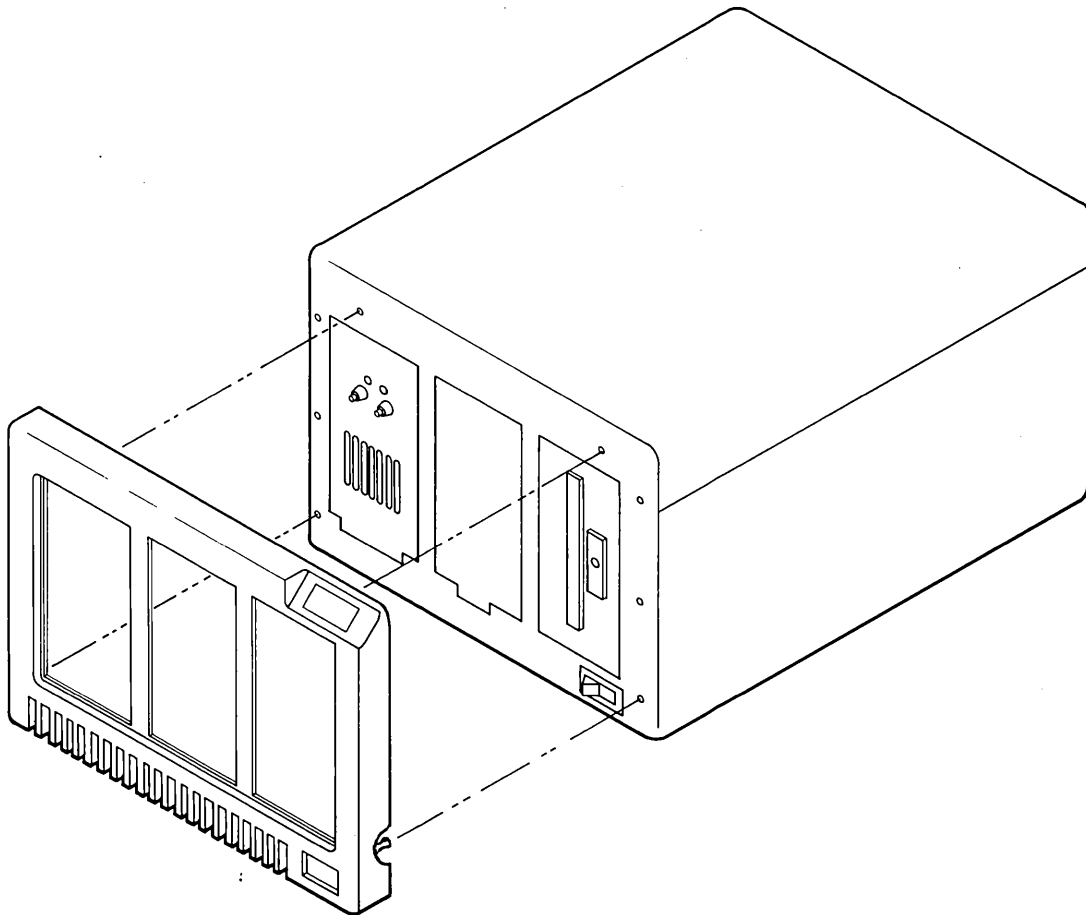

Figure 4-2. Front Panel Location

MAINTENANCE

4-7. Top Cover Removal and Replacement Procedure

The top cover is removed to gain access to the card cage, power supply connectors, and the boards within the card cage. To remove the top cover, loosen four quarter turn fasteners and remove the top cover. (Refer to Figure 4-3.)

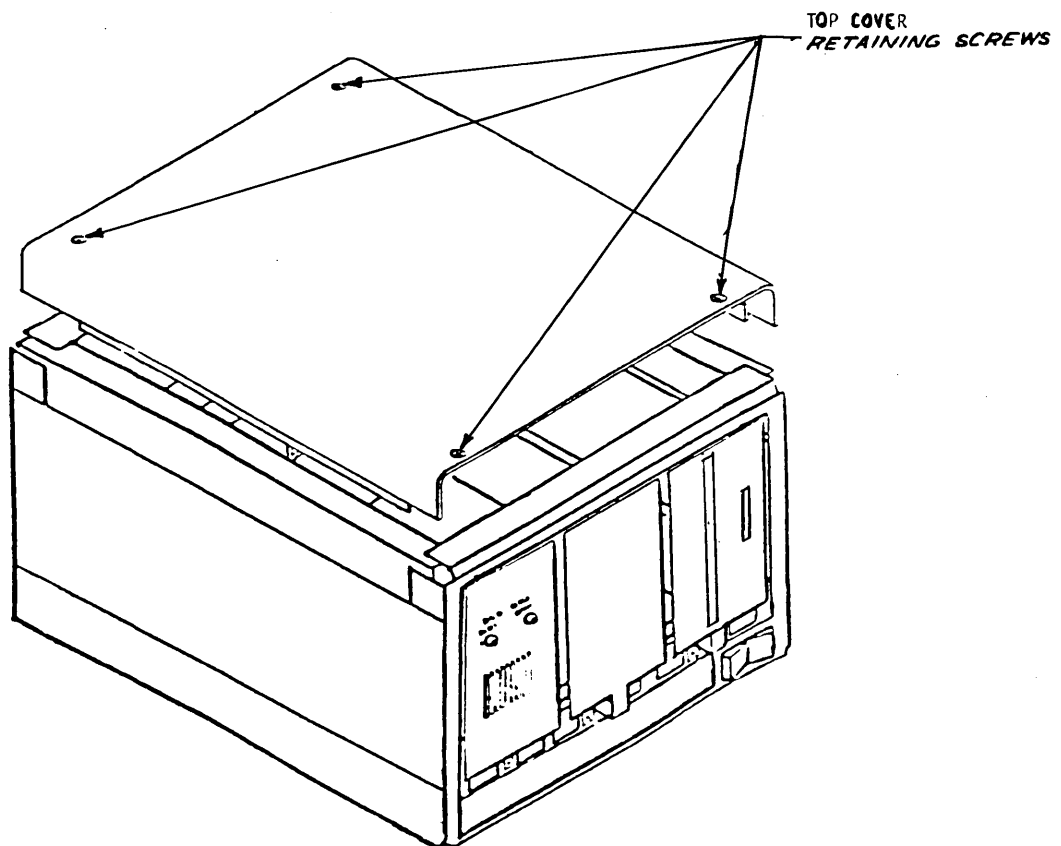

Figure 4-3. Top Cover Location

MAINTENANCE

4-8. Filler Panel Removal and Replacement Procedure

The Filler panel is removed to gain access to the Winchester drive. To remove the Filler panel, proceed as follows:

1. Turn AC power switch to OFF.

WARNING

Never attempt to service any sub-assembly within the chassis with the AC power cord connected. Hazardous voltages are present within the chassis with the AC cord connected to a power source.

2. Disconnect the AC power cord from the power source.
3. Remove the top cover.
4. Remove the front panel.
5. Remove two screws securing the filler panel to the chassis and remove the filler panel. (Refer to Figure 4-4.)

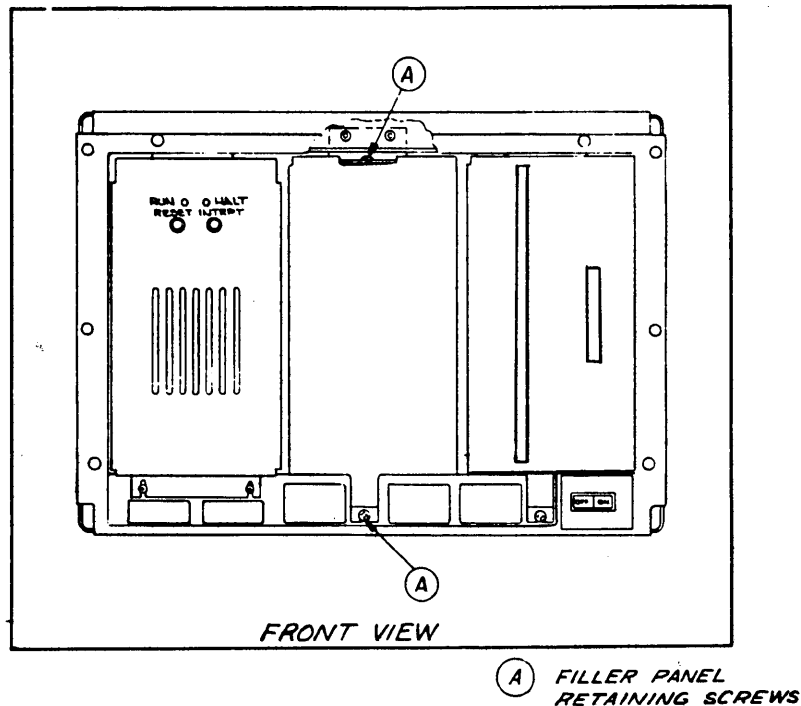

Figure 4-4. Filler Panel Retaining Screw Locations

MAINTENANCE

4-9. Top Support Angle Bracket Removal and Replacement Procedure

The top support bracket is removed to gain access to the boards. To remove the top support angle bracket, proceed as follows:

1. Turn AC power switch to OFF.

WARNING

Never attempt to service any sub-assembly within the chassis with the AC power cord connected. Hazardous voltages are present within the chassis with the AC power cord connected to a power source.

2. Disconnect the AC power cord from the power source.
3. Remove the top cover.
4. Remove four screws securing the top support angle bracket to the chassis and both drives. (Refer to Figure 4-5.)

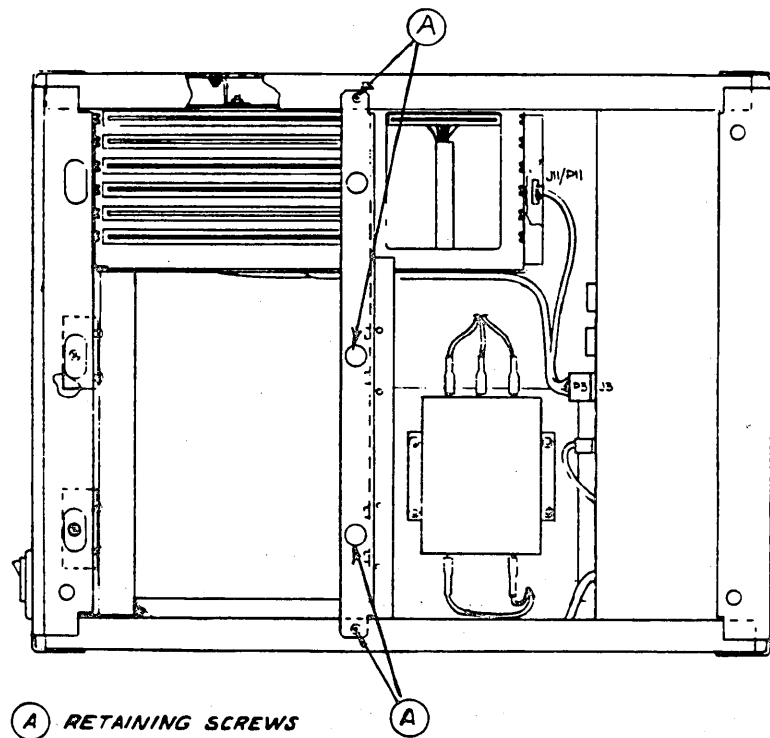

Figure 4-5. Top Angle Bracket Retaining Screw Locations

MAINTENANCE

4-10. Winchester Removal and Replacement Procedure

The Winchester drive should be replaced as a corrective action when referenced in the troubleshooting guide or to gain access to replace the card cage, or filter 2. To replace the Winchester drive, proceed as follows:

1. Turn AC power switch to OFF.

WARNING

Never attempt to service any sub-assembly within the chassis with the AC power cord connected. Hazardous voltages are present within the chassis with the AC power cord connected to a power source.

2. Disconnect the AC power cord from the power source.
3. Remove the top cover and front panel.
4. Remove the filler panel and lock the shipping restraint.
5. Disconnect the power cable and the signal cable from the Winchester drive. (Refer to Figure 4-6.)
6. Remove three screws securing the drive to the chassis.
7. Slide Winchester drive from chassis.
8. Remove slide bracket from drive and install onto replacement drive.
9. Reassemble. Assembly is the reverse order of removal.

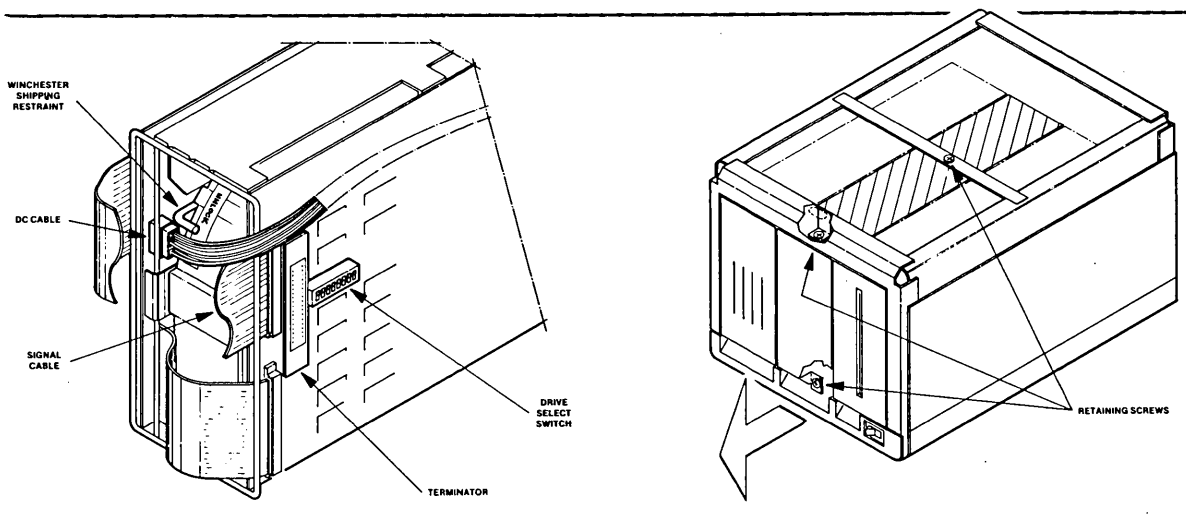

Figure 4-6. Winchester Drive Retaining Screw Locations

MAINTENANCE

4-11. Flexible Disk Drive Removal and Replacement Procedure

The Flexible disk drive is removed as a corrective action when referenced by the troubleshooting guide or to gain access to filter 2. To remove the flexible disk drive, proceed as follows:

1. Turn the AC power switch to OFF.

WARNING

Never attempt to service any sub-assembly within the chassis with the power cord connected. Hazardous voltages are present within the chassis with the AC cord connected to a power source.

2. Disconnect the AC power cord from the power source.
3. Remove the top panel.
4. Remove the front panel.
5. Remove three screws securing drive to chassis. (Refer to Figure 4-7.)
6. Slide drive forward until connectors are accessible.
7. Disconnect the signal, AC, and DC cables from the drive.
8. Remove drive from chassis.
9. Remove slide bracket from drive and install onto replacement drive.

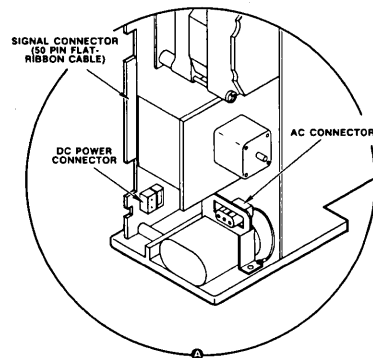
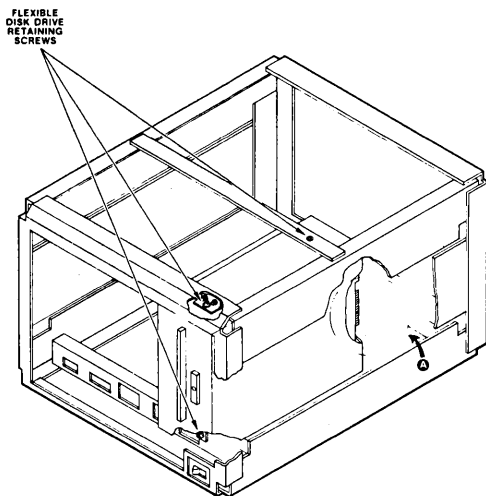

NOTE:
If drive is being daisy-chained, remove terminator(s) from all drives except the last one on the chain.

Figure 4-7. Flexible Disk Drive Retaining Screw Locations

MAINTENANCE

4-12. Power Supply Removal and Replacement Procedure

The power supply is removed as corrective action when referenced by the troubleshooting guide. To remove the power supply, proceed as follows:

1. Turn the AC power switch to OFF.

WARNING

Never attempt to service any sub-assembly within the chassis with the AC power cord connected. Hazardous voltages are present within the chassis with the AC power cord connected to a power source.

2. Disconnect the AC power cord from the power source.
3. Remove the top cover.
4. Remove the front panel.
5. Remove the filler panel.
6. Remove three screws securing the Winchester drive to the chassis.
7. Slide the Winchester drive forward until the three wires attached to filter 2 are accessible. (Refer to Figure 4-8.)
8. Disconnect all connectors (P5, P4, P3, P2) from the front of the power supply.
9. Remove the three wires to filter 2.

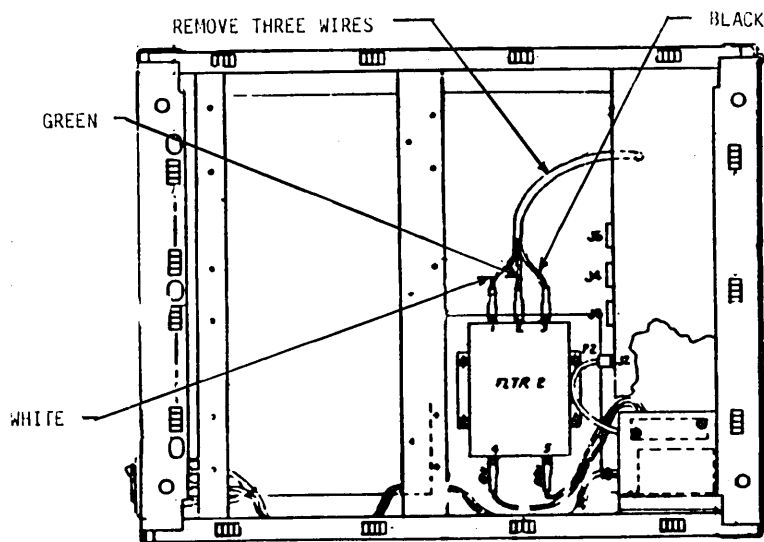

Figure 4-8. Filter 2 Terminal Wire Locations

MAINTENANCE

10. Loosen two screws securing the pin adapter board extension bracket to the power supply. Ease the pin adapter board out of the way. (Refer to Figure 4-9.)

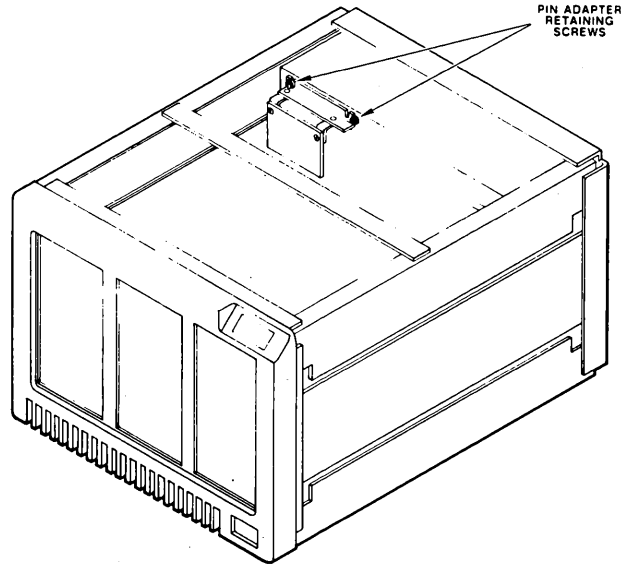

Figure 4-9. Pin Adapter Retaining Screw Locations

11. Remove six screws securing the power supply to the chassis. (Refer to Figure 4-10.)

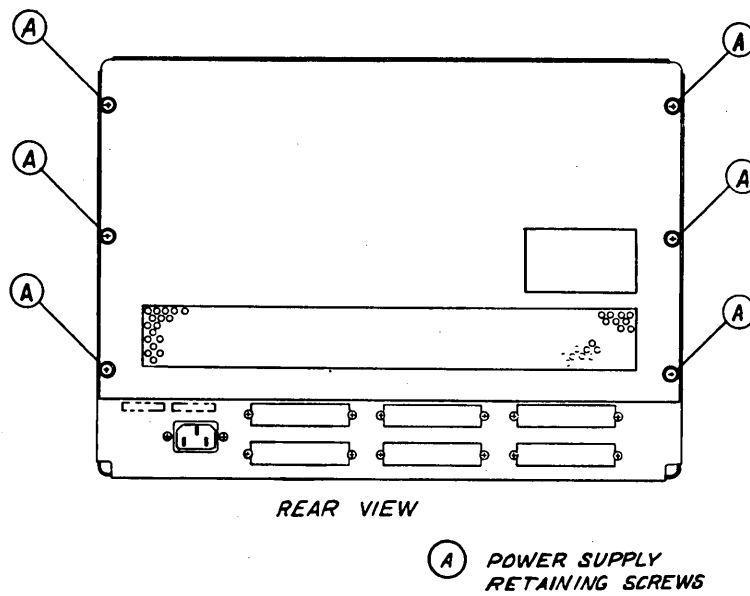

Figure 4-10. Power Supply Retaining Screw Locations

MAINTENANCE

12. Ease the power supply out from the back of the chassis until the power cable from filter 2 just contacts the lower rear connector panel. Tilt the power supply back and lift out.

NOTE

The power supply weighs about 15 pounds.

13. With the power supply out, remove the bracket from the power supply.

CAUTION

Do not replace fuses. Replacing a blown fuse resulting from a component failure will result in additional damage to the power supply circuitry.

4-13. Card Cage Removal and Replacement Procedure

To remove the card cage, proceed as follows:

1. Turn the AC power switch to OFF.

WARNING

Never attempt to service any sub-assembly within the chassis with the AC power cord connected. Hazardous voltages are present within the chassis with the AC cord connected to a power source.

2. Disconnect the AC cord from the power source.
3. Remove the top panel and left side panel.
4. Remove the four screws securing the top support angle bracket to the chassis and drives.
5. Remove the filler panel.
6. Remove the Winchester drive.
7. Disconnect connector P3 from the power supply.
8. Remove the card retainer. (Refer to Figure 4-11.)

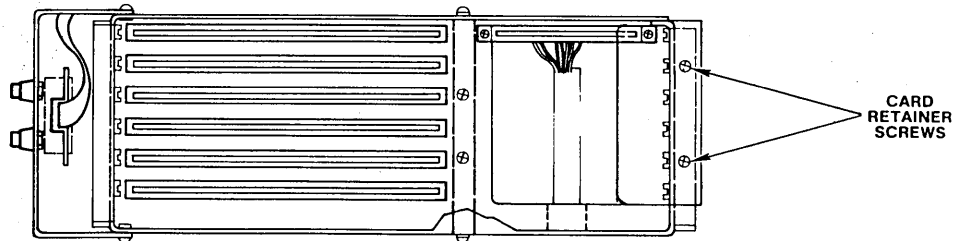

Figure 4-11. Card Cage Board Clamp Retaining Screw Locations

9. Disconnect all cables from the boards and remove all boards.
10. Remove the five screws securing the card cage to the chassis, see Figure 4-12.

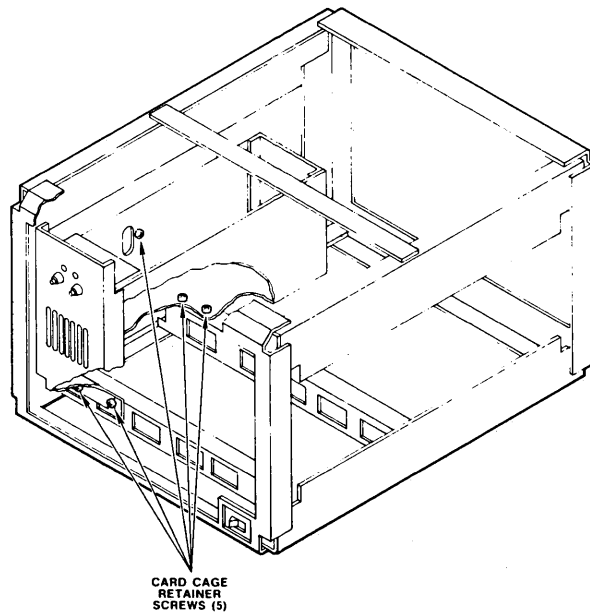

Figure 4-12. Card Cage Retaining Screw Locations

MAINTENANCE

11. Lift card cage and front panel out through the front of the chassis.
12. When installing the replacement card cage, loosen the four screws securing the front panel to the card cage and position the front panel toward the card cage.
13. Referring to Figure 4-13, align the holes in the card cage marked A and B first, install the three screws and then install the screws in the hole marked C. Tighten the five screws, then reposition the front panel and tighten the front panel retaining screws.

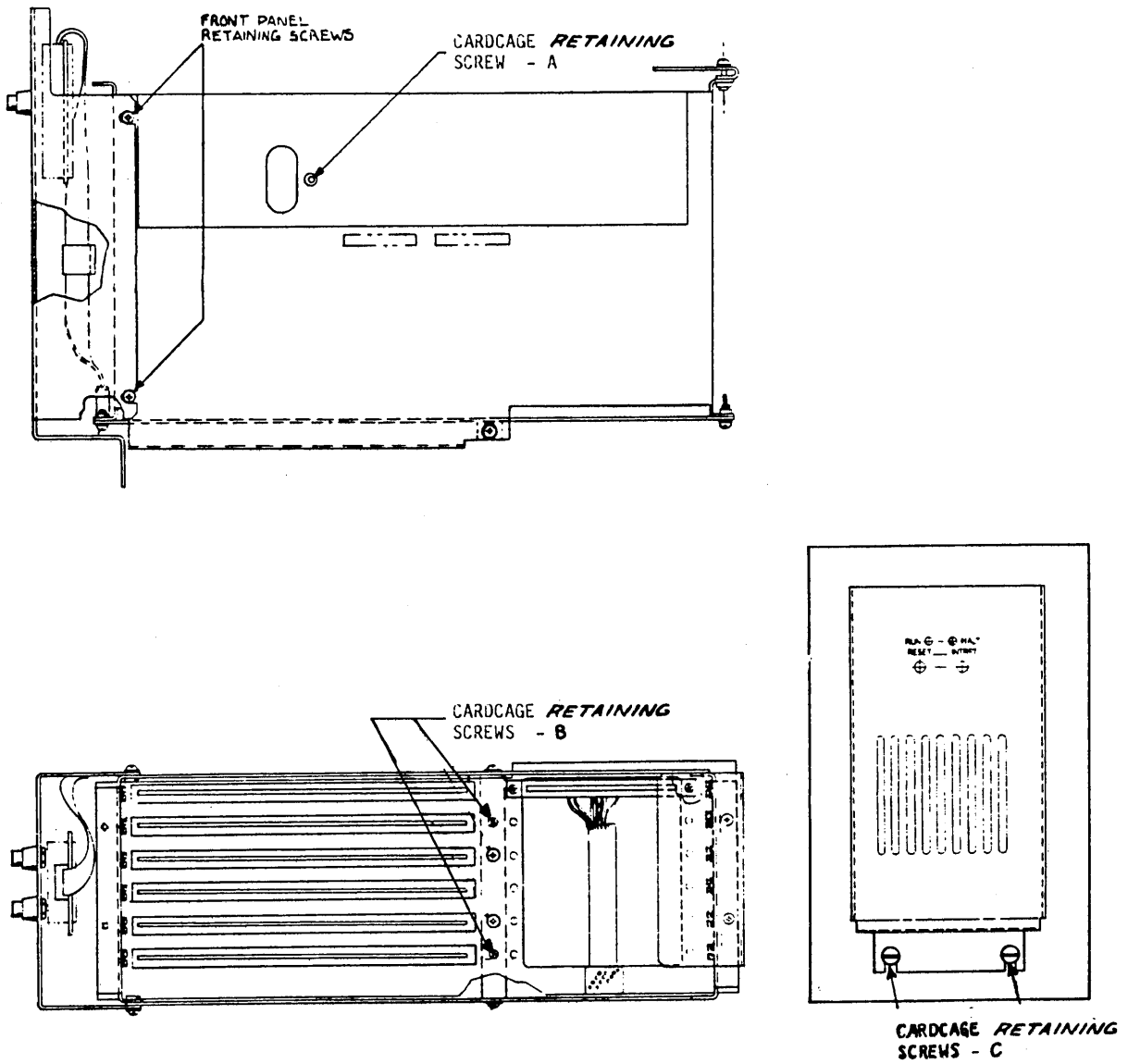

Figure 4-13. Installation Sequence of Card Cage Retaining Screws

MAINTENANCE

4-14. AC Power Switch Removal and Replacement Procedure

To replace the power switch, proceed as follows:

1. Turn the AC power switch to OFF.

WARNING

Never attempt to service any sub-assembly within the chassis with the AC power cord connected. Hazardous voltages are present within the chassis with the AC cord connected to a power source.

2. Disconnect the AC power cord from the power source.
3. Remove the top cover.
4. Remove the front panel.
5. Remove the flexible disk drive.
6. Reaching inside, squeeze the retaining clips on each side of the switch (see Figure 4-14) and push the switch out through the front.

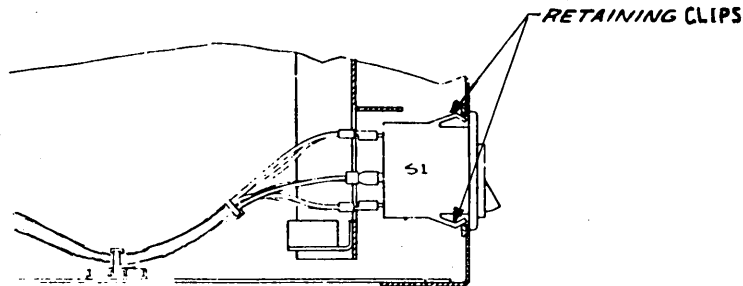

Figure 4-14. Switch Retaining Clips

7. Remove the six terminal lugs from the switch.
8. Insert the replacement switch.

MAINTENANCE

9. Viewing the switch from the back of the unit, connect the terminal lugs to the switch as shown in Figure 4-15.

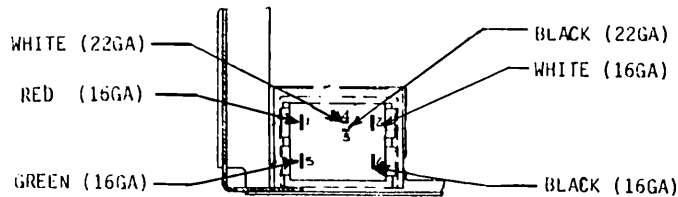

Figure 4-15. Rear View of Switch

4-15. Filter 2 Removal and Replacement Procedure

To remove Filter 2, proceed as follows:

1. Turn AC power switch to OFF.

WARNING

Never attempt to service any sub-assembly within the chassis with the AC power cord connected. Hazardous voltages are present within the chassis with the AC power cord connected to a power source.

2. Disconnect the AC power cord from the power source.
3. Remove the top cover.
4. Remove the front panel.
5. Remove the filler panel and Winchester drive.
6. Remove the flexible disk drive.
7. Disconnect the three wires leading from filter 2 to the power supply. (Refer to Figure 4-16.)
8. Disconnect the two wires from filter 2 leading to the terminal strip.
9. Remove five screws securing the drive base slide to the chassis and remove drive base slide.

MAINTENANCE

10. Remove four nuts securing filter 2 to the chassis and remove filter 2.

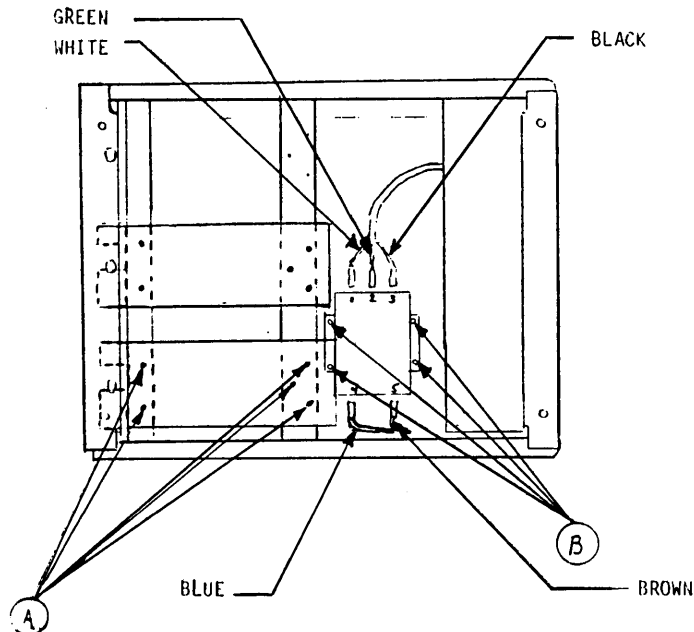

Figure 4-16. Filter 2 Terminal Locations

4-16. Bottom Cover Removal and Replacement Procedure

The bottom cover is removed to gain access to the mounting screws for filter 1. To remove the bottom cover, proceed as follows:

1. Turn the AC power switch to OFF.

WARNING

Never attempt to service any sub-assembly within the chassis with the AC power cord connected. Hazardous voltages are present within the chassis with the AC power cord connected to a power source.

2. Disconnect the AC power cord from the power source.

MAINTENANCE

CAUTION

Exercise care when turning the unit over to gain access to the four screws securing the bottom cover to the chassis. If the Winchester drive is subjected to shock where the platters are parallel to the shock surface, media pitting may result.

3. Turn the chassis over to gain access to the four screws securing the bottom cover to the chassis.
4. Remove four screws securing the bottom cover to the chassis and remove bottom cover. (Refer to Figure 4-17.)

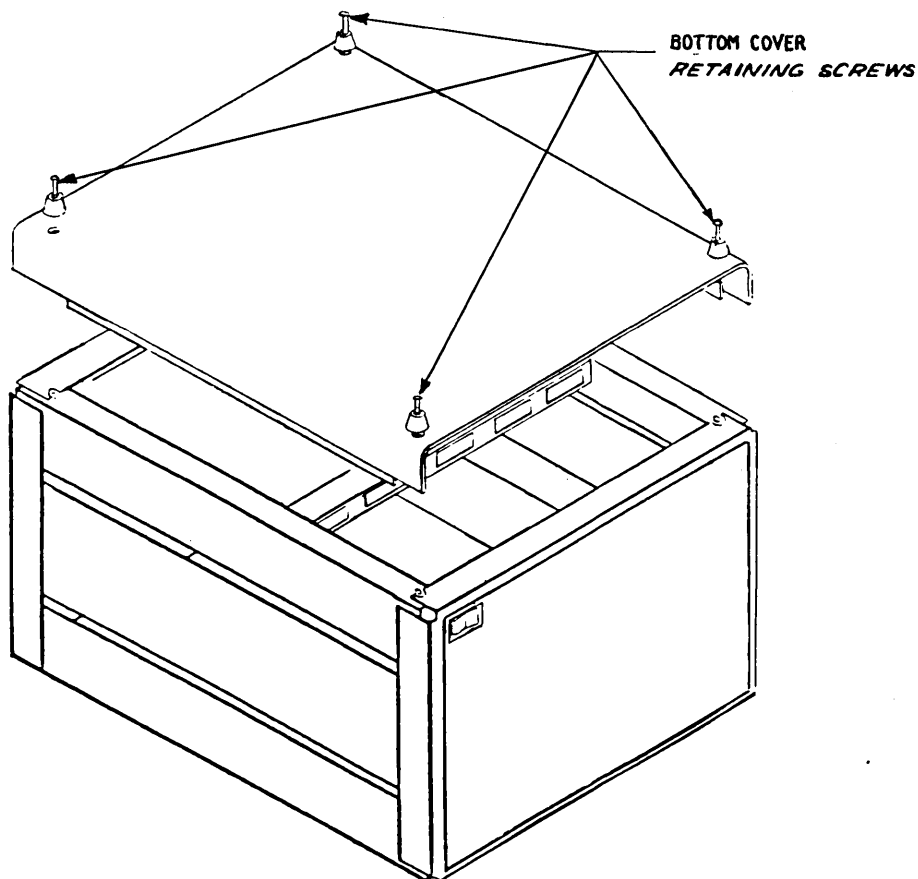

Figure 4-17. Bottom Cover Retaining Screw Locations

MAINTENANCE

4-17. Filter 1 Removal and Replacement Procedure

To remove filter 1, proceed as follows:

1. Turn AC power switch to OFF.

WARNING

Never attempt to service any sub-assembly within the chassis with the AC power cord connected. Hazardous voltages are present within the chassis with the AC power cord connected to the power source.

2. Disconnect the AC power cord from the power source.
3. Remove the bottom cover.
4. Disconnect four leads to filter 1, see Figure 4-18.
5. Remove two screws securing filter 1 to the chassis and remove filter 1.
6. Reassemble. (Assembly is the reverse order of disassembly.)

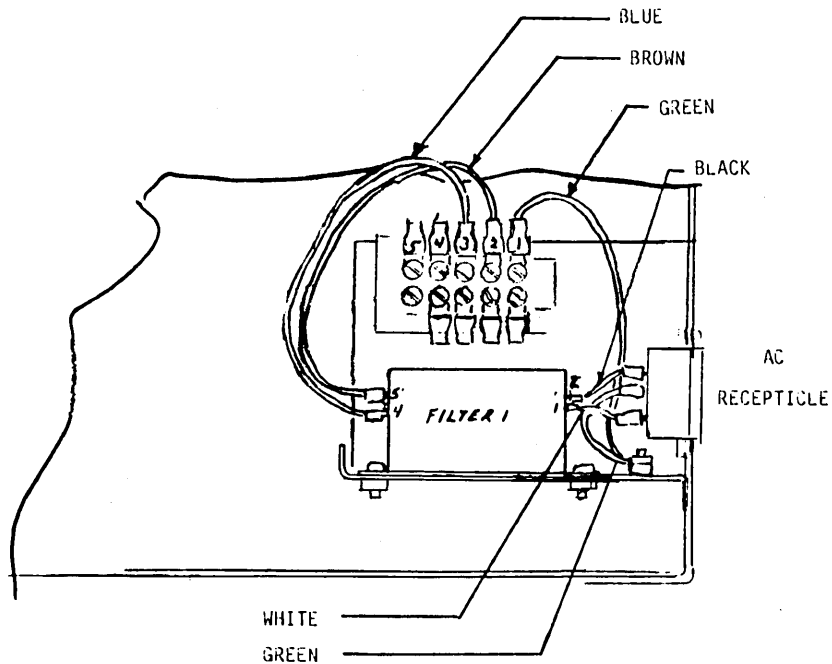

Figure 4-18. Filter And Terminal Locations

MAINTENANCE

4-18. AC Power Switch Lamp Removal and Replacement Procedure

The AC power switch lamp lights when plus 5 volts DC power from the power supply is available. To remove the AC power switch lamp, proceed as follows:

1. Turn the AC power switch to OFF.

WARNING

Never attempt to service any sub-assembly within the chassis with the AC power cord connected. Hazardous voltages are present within the chassis.

2. Disconnect the AC power cord from the power source.
3. Remove the plastic cover, see Figure 4-19.
4. Unsolder the two leads of the lamp.

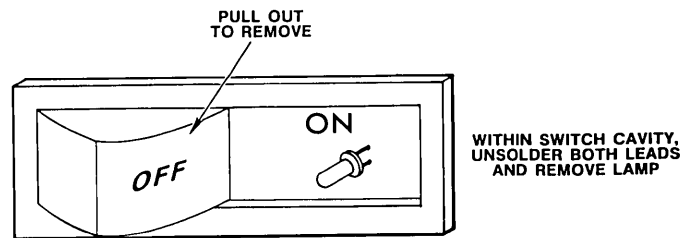

Figure 4-19. AC Power Switch Lamp Location

CHAPTER 5. SERVICE INFORMATION

5-1. INTRODUCTION

This chapter provides service and repair assistance information. For personnel safety and system component protection, refer all servicing to qualified personnel only.

5-2. SERVICE AND REPAIR ASSISTANCE

The best service for your Intel product is provided by an Intel Customer Engineer. These trained professionals will provide prompt, efficient on-site installation, preventive maintenance, or corrective maintenance services that will keep your equipment in the best possible operating condition.

Your Intel Customer Engineer can provide the service you need through a prepaid service contract or on an hourly charge basis. For further information, contact your local Intel office.

When an Intel Customer Engineer is is not available in your local area, you may contact the Intel Product Service Hotline directly at one of the following numbers:

Telephone:

From Alaska, Arizona, or Hawaii call - (602) 869-4600

From all other US locations call toll free - (800) 528-0595
TWX: 910-951-1330

Before calling the Product Service Hotline, you should have the following information available:

- a. Date you received the product.
- b. Complete part number of the product (including dash number). On boards, this number is usually silk-screened onto the board. On other Intel products it is usually stamped on a label.
- c. Serial number of product. On boards, this number is usually stamped on the board. On other Intel products the serial number is usually stamped on a label.

SERVICE INFORMATION

- d. Shipping and billing address.
- e. If your Intel product warranty has expired, you must provide a purchase order number for billing purposes.
- f. If you have an extended warranty agreement, be sure to advise the the Hotline personnel of this agreement.

Never return equipment to Intel for service or repair until after you contact an local Product Service office or the Product Service Hotline.

If return of your equipment is necessary, you will be given a Repair Authorization Number, shipping instructions, and other important information that will help Intel provide you with fast, efficient service. If the product is being returned because of damage sustained during shipment, or if the product is out of warranty, a purchase order is necessary in order for the Intel Repair Center to make the repair.

When preparing the product for shipment to the Repair Center, use the original factory packaging material if available. If the original packaging material is not available, wrap the product in a cushioning material such as Air Cap SD-240, manufactured by the Sealed Air Corporation, Hawthorne, N.J. (or equivalent) and enclose in a heavy-duty corrugated shipping carton securely, mark it "FRAGILE" to ensure careful handling, and ship it to the address specified by the Intel Repair Center.

NOTE

Customers outside of the United States should contact their sales source (Intel Sales Office or Authorized Intel Distributor) for directions on obtaining service or repair assistance.

CHAPTER 6. MAINTENANCE DIAGRAMS

6-1. INTRODUCTION

This Chapter provides a replacement parts list (refer to Table 6-1) and maintenance diagrams Figures 6-1 through 6-21.

Table 6-1. Replacement Parts List

Ref Desg.	Description	Intel Part No.	Qty/ Assy.
	Chassis	162112	1
	Front Panel, Desk	162139	1
	Desk Top Side Panels	144189	2
	Front Panel, Rack Mount	162135	1
	Top Cover	162128	1
	Bottom Cover	162131	1
	Filler Panel	144103	1
	Rack Mount Left Side Panel	144189	1
	Rack Mount Right Side Panel	144189	1
	Top Support Angle	162266	1
	Top Support Bracket	144035	4
A9	AC Recepticle Assy	162560	1
TB1	Term Block Assy	162573	1
W13	GRN Wire Assy	162378	1
W12, W15	BLU Wire Assy	164378	1
W11, W14	BRN Wire Assy	162378	1
	125V Cord Set	102196	1
FL1	10AMP Line Filter	161823	1
FL2	10AMP Line Filter	107522	1
CB1	10AMP Circuit Breaker	104257	1
W9	Cable Breaker Assy	162114	1
A8	Pin Adapter Assy	143502	1
W6	Daisy Chain Cable Assy	144247	1
	Power Supply	162491	1
W7	DC WINI Cable Assy	143500	1
W10	AC Floppy Cable Assy	143492	1
W8	DC Floppy Cable Assy	143493	1
	Card Cage Assy	162401	1
	Card Cage Bracket	162423	1
	Card Clamp	162405	1
A5	Processor Assy	143484	1
W4	Serial I/O Cable Assy	143869	1
W2	Line Print Cable Assy	143868	1
	iSBC 300	1001798	
	iSBC 337	142696	

MAINTENANCE DIAGRAMS

Table 6-1. Replacement Parts List (continued)

Ref Desg.	Description	Intel Part No.	Qty/ Assy.
W6	Disk Controller Assy	143489	1
	iSBC 215 Winchester Controller	162037	
	iSBX 218 Flex Disc Controller	162057	
W5	Radial Cable Assy	143505	1
W1	Command Cable Assy	143506	1
W3	Signal FLP Cable Assy	143494	1
A7	iSBC 056 PWA Assy	144170	1
A3	Floppy Disk Drive	143496	1
	Drive Mount Slide	162121	2
	Drive Mount Base	162122	2
A4	Winchester Drive	124698	1

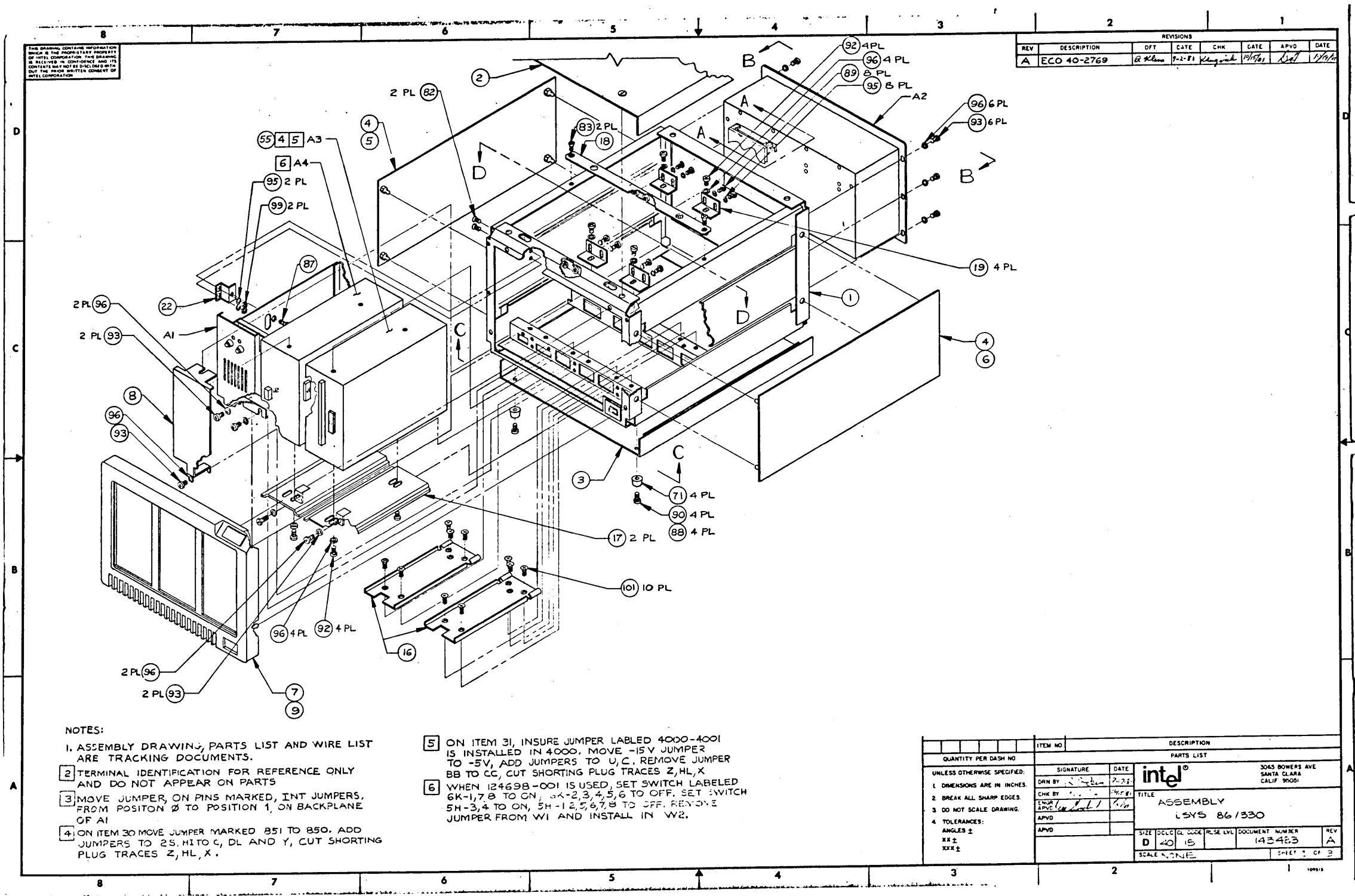

Figure 6-1. System 86/330 Exploded View 6-3/6-4

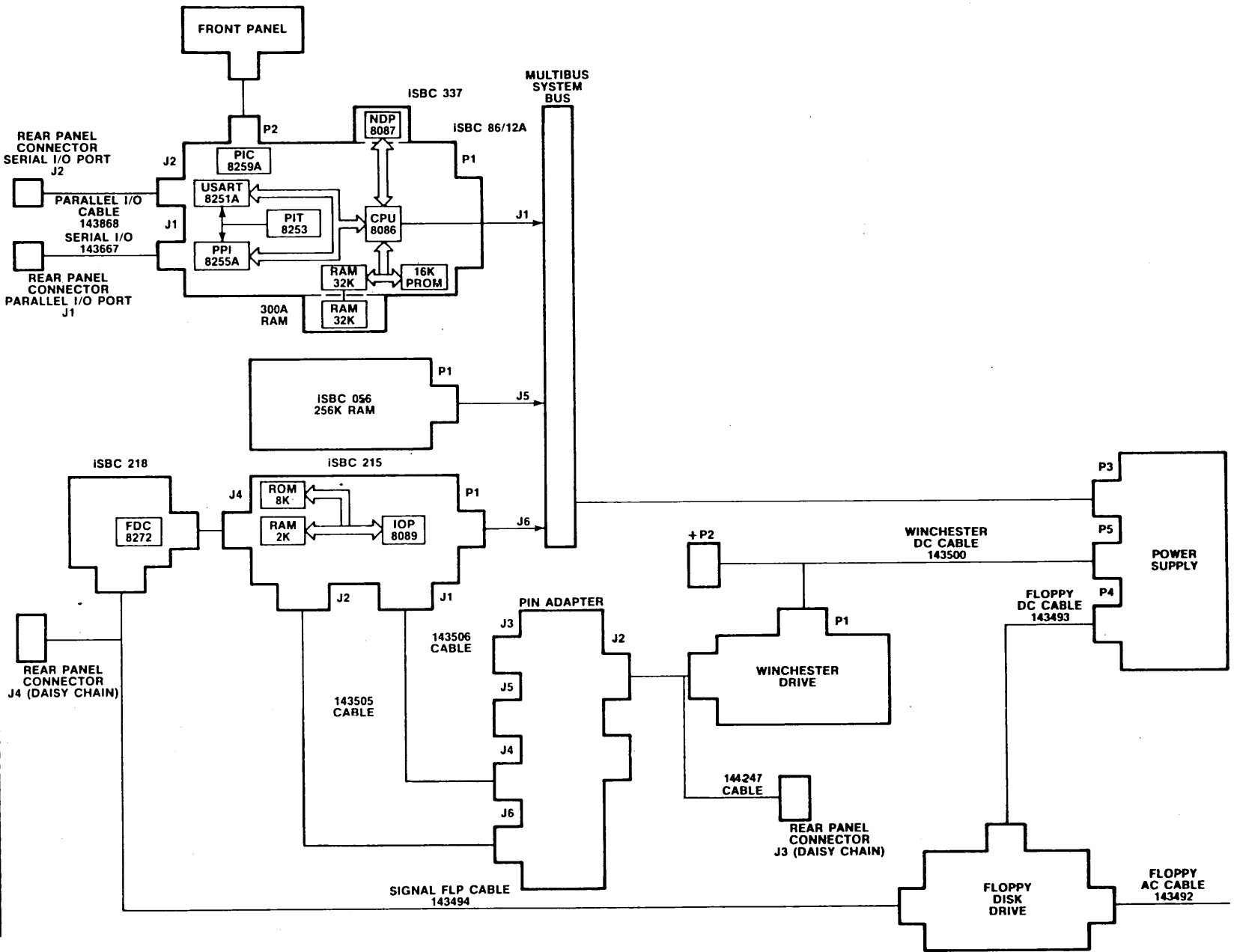

Figure 6-2. System 86/330 Interconnection Diagram

MAINTENANCE DIAGRAMS

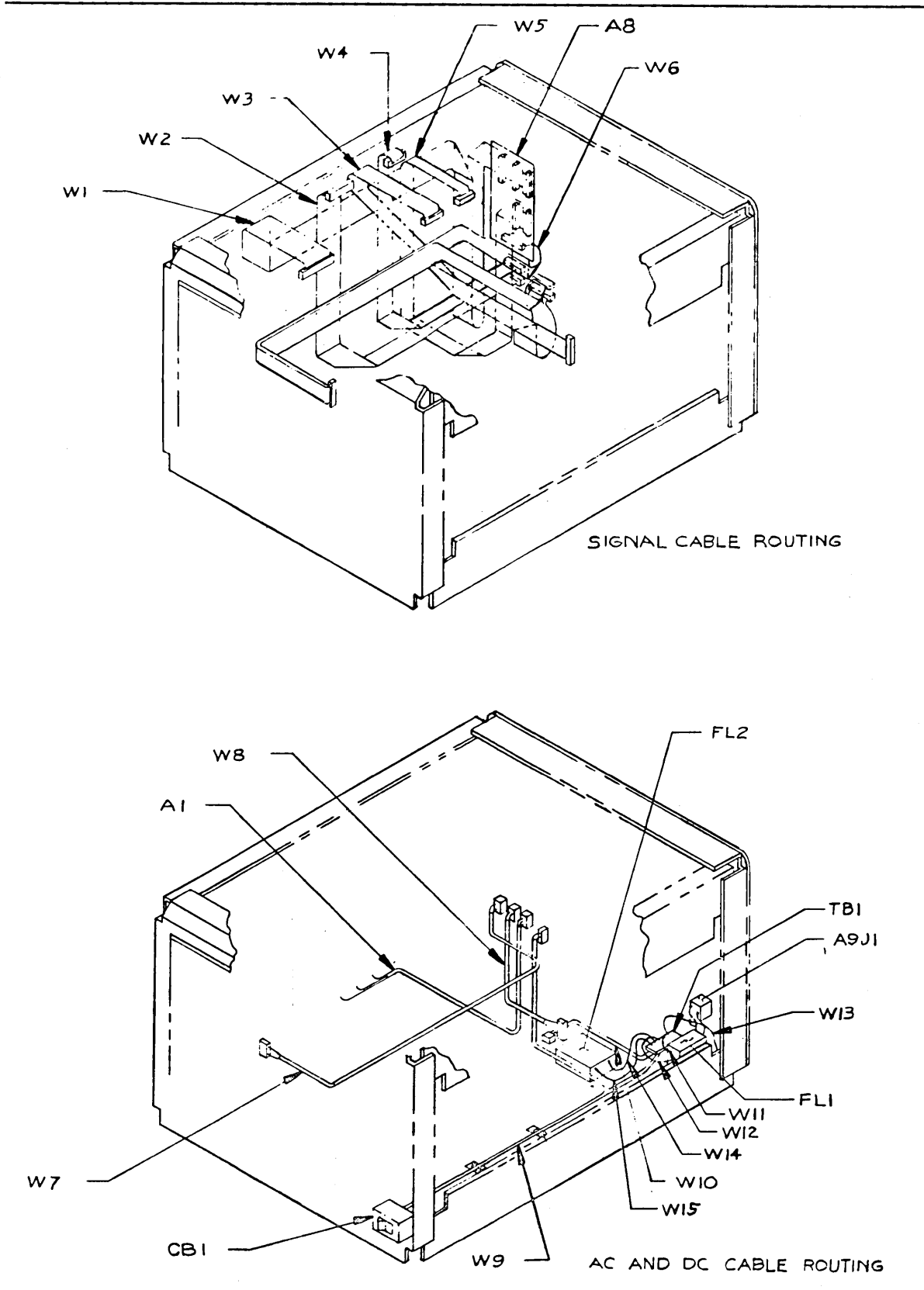
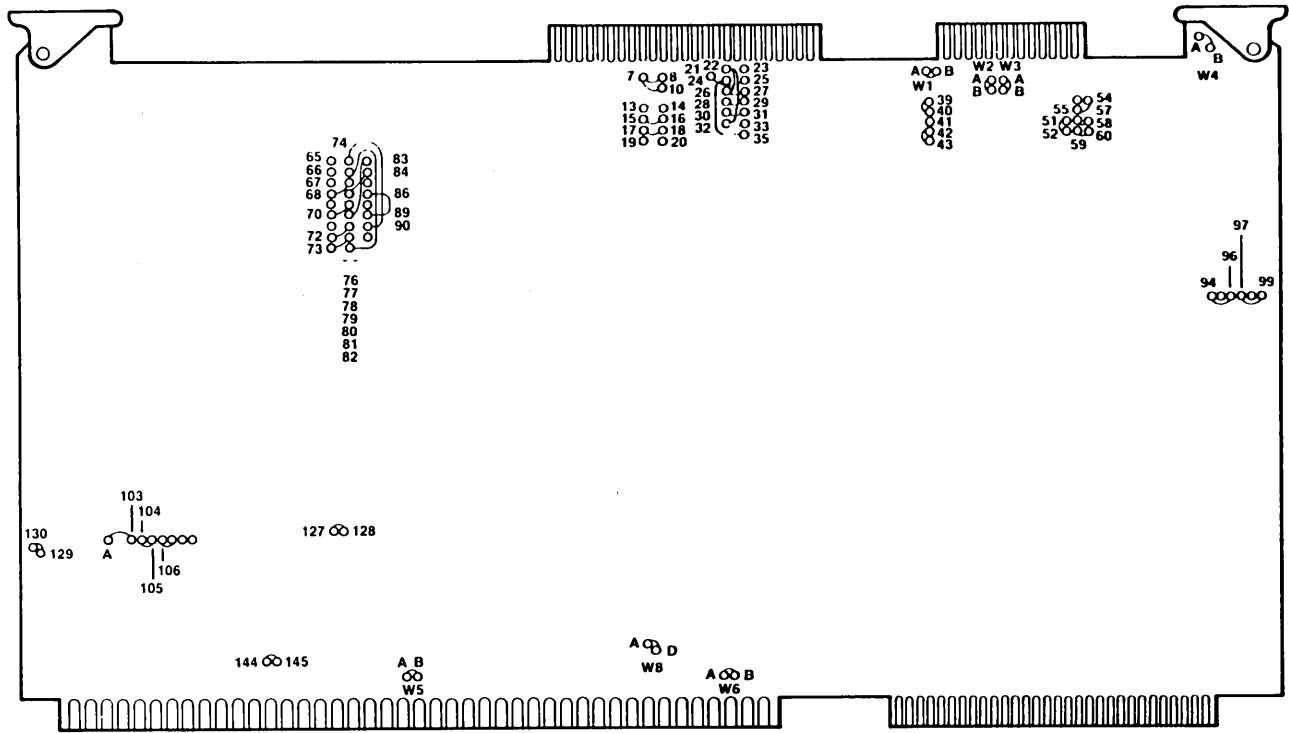

Figure 6-3. System 86/330 Cable Routing Diagram

MAINTENANCE DIAGRAMS



- | | |
|----------|-------------|
| 1 to 81 | 68 to 76 |
| 3 to 4 | 70 to 78 |
| 5 to 6 | 72 to 80 |
| 7 to 8 | 73 to 81 |
| 7 to 10 | 74 to 90 |
| 22 to 26 | 75 to 82 |
| 15 to 16 | 77 to 84 |
| 17 to 18 | 79 to 83 |
| 19 to 20 | 86 to 89 |
| 21 to 25 | 94 to 96 |
| 24 to 35 | 97 to 99 |
| 26 to 27 | 103 to 104 |
| 28 to 29 | 105 to 106 |
| 22 to 32 | 127 to 128 |
| 32 to 33 | 129 to 130 |
| 39 to 40 | 144 to 145 |
| 42 to 43 | W1 (A to B) |
| 47 to 52 | W2 (A to B) |
| 54 to 55 | W3 (A to B) |
| 57 to 58 | W4 (A to B) |
| 59 to 60 | W5 (A to B) |
| 51 to 52 | W6 (A to B) |

S1-2,3,4,5,6,8 - open
S1-1, 7 closed

Figure 6-4. iSBC™ 86/12A Jumper Configuration

MAINTENANCE DIAGRAMS

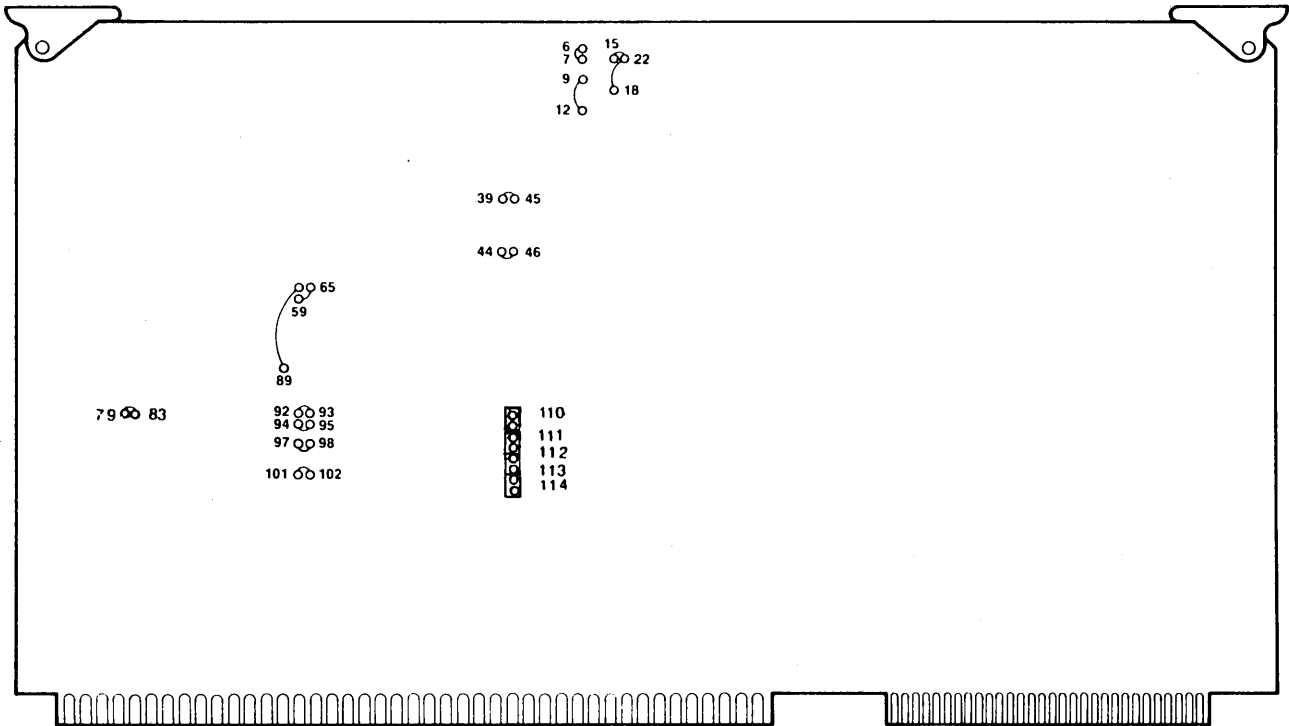

BOARD CAPACITY	256K	
MEMORY DEVICE	2164	
JUMPERS	FROM	TO
	E7	E6
	E22	E15
	E22	E18
	E45	E39
	E46	E44
	E92	E93
	E94	E95
	E97	E98
	E101	E102
	E59	E65
	E9	E12
	E89	E58
E79	F83	
E110	E111	
E110	E112	
E110	E113	
E110	E114	
UNUSED DEVICES	U1, 20	

Figure 6-5. iSBC™ 056 Jumper Configuration

MAINTENANCE DIAGRAMS

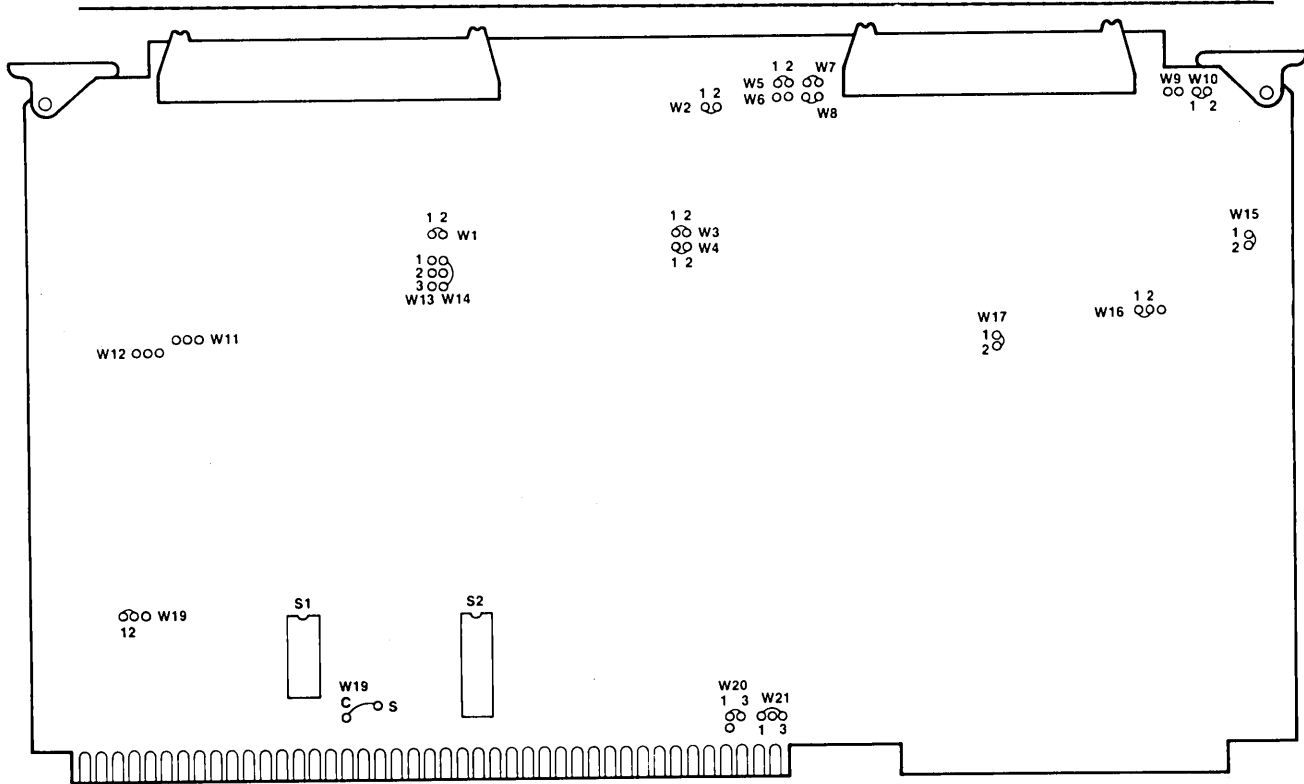

Jumper No.	Position	
	Type 1	Type 2
W1	1 to 2	1 to 2
W2	—	1 to 2
W3	1 to 2	1 to 2
W4	1 to 2	1 to 2
W5	1 to 2	1 to 2
W6	1 to 2	1 to 2
W7	1 to 2	1 to 2
W8	1 to 2	1 to 2
W9	—	—
W10	1 to 2	1 to 2
W11		
W12		
W13	1 to 2	1 to 3
W14	1 to 3	1 to 3
W15	1 to 2	1 to 2
W16	1 to 2	1 to 3
W17	1 to 2	—
W18	1 to 2	1 to 2
W19	c to 5	c to 5
W20	1 to 3	1 to 3
W21	1 to 3	1 to 3
W22	1 to 3	1 to 2
W23	1 to 2	1 to 2

Wakeup Address S1-1,2,3,4,5,6,7 - open
 Select S1-8 closed
 16 bit System + I/O: S2-3,4,5,6,7,8,9,10 - open
 S2-1,2, closed

Figure 6-6. iSBC™ 215 Jumper Configuration

MAINTENANCE DIAGRAMS

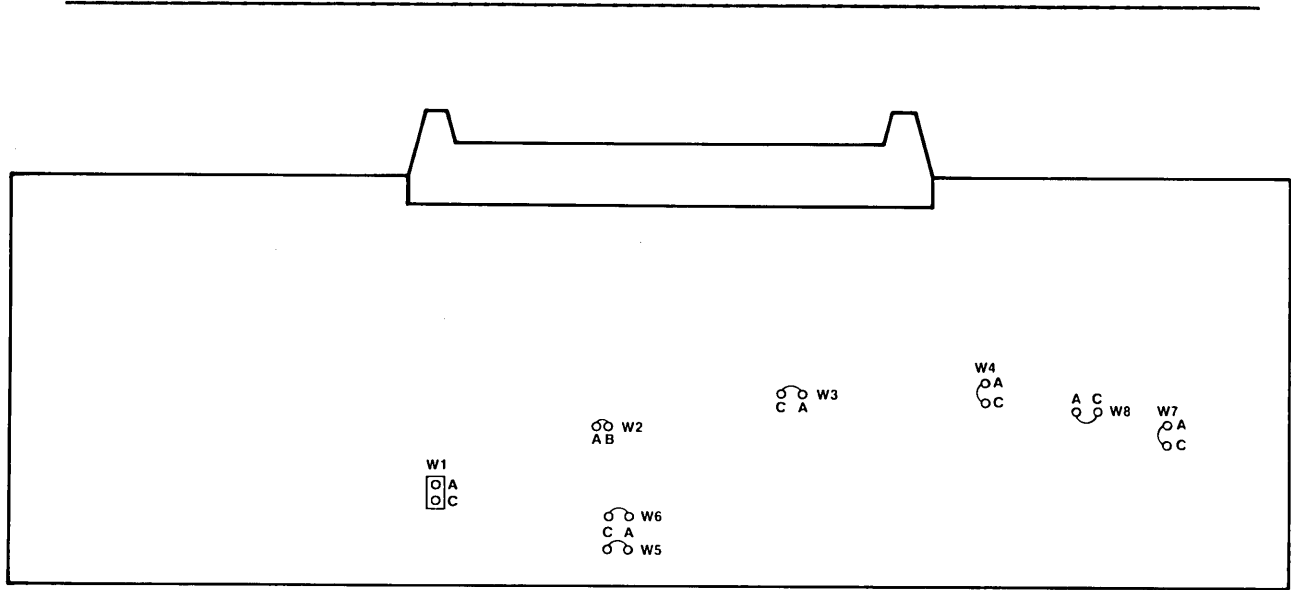

W1	A to C
W2	A to B
W3	A to C
W4	A to C
W5	A to C
W6	A to C
W7	A to C
W8	A to C

Figure 6-7. 1SBX™ 218 Jumper Configuration

MAINTENANCE DIAGRAMS

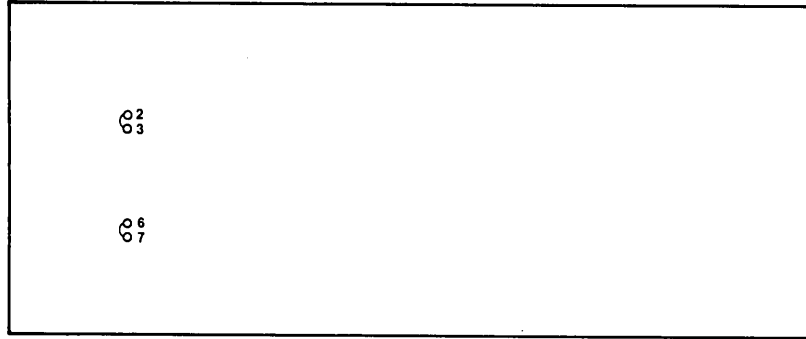

Figure 6-8. iSBC™ 300 Jumper Configuration

MAINTENANCE DIAGRAMS

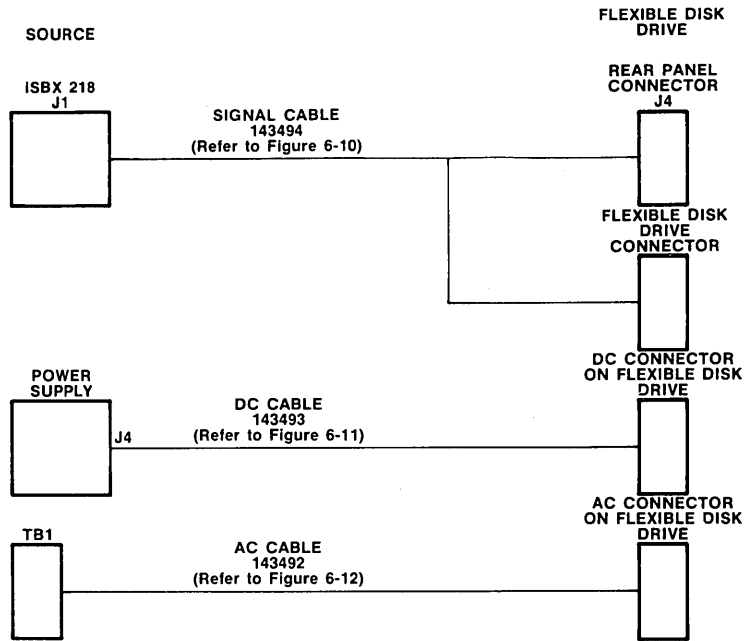

Figure 6-9. Flexible Disk Drive Cables

MAINTENANCE DIAGRAMS

LSBX218 Connector J1 Pin Out

Pin	Description	Pin	Description
1	Signal Ground	2	Low Current/
3	Signal Ground	4	Fault Reset/
5	Signal Ground	6	Fault/
7	Signal Ground	8	Reserved
9	Signal Ground	10	Two-Sided/
11	Signal Ground	12	Reserved
13	Signal Ground	14	Side Select
15	Signal Ground	16	Reserved
17	Signal Ground	18	Head Load/
19	Signal Ground	20	Index/
21	Signal Ground	22	Ready/
23	Signal Ground	24	Reserved
25	Signal Ground	26	Drive 0 Sel/
27	Signal Ground	28	Drive 1 Sel/
29	Signal Ground	30	Drive 2 Sel/
31	Signal Ground	32	Drive 3 Sel/
33	Signal Ground	34	Direction
35	Signal Ground	36	Step/
37	Signal Ground	38	Write Data/
39	Signal Ground	40	Write Enable/
41	Signal Ground	42	Track 00/
43	Signal Ground	44	Write Protect/
45	Signal Ground	46	Read Data/
47	Signal Ground	48	Reserved
49	Signal Ground	50	Reserved

Typical Drive Interface Pinout

Drive Connector Pin Number	Signal Name
1-49 odd	Ground
2	Write Current Switch
NC	
NC	
NC	
10	Two-sided
12	Disk Change
14	Side Select
16	In Use
18	Head Load
20	Index
22	Ready
24	Sector
26	Drive Select 1
28	Drive Select 2
30	Drive Select 3
32	Drive Select 4
34	Direction Select
36	Step
38	Write Data
40	Write Gate
42	Track 00
44	Write Protect
46	Read Data
48	FM Sep Data
50	FM Sep Clock

Figure 6-10. Flexible Disk Drive Signal Cable (143494)
Pin Assignments

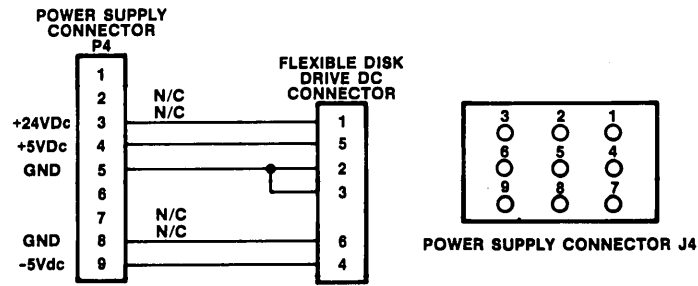

Figure 6-11. Flexible Disk Drive DC Cable (143493)
Connector Pinout

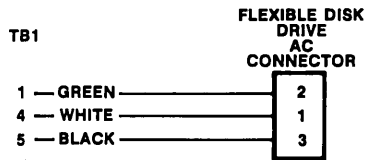

Figure 6-12. Flexible Disk Drive AC Cable (143492)
Connector Pinout

MAINTENANCE DIAGRAMS

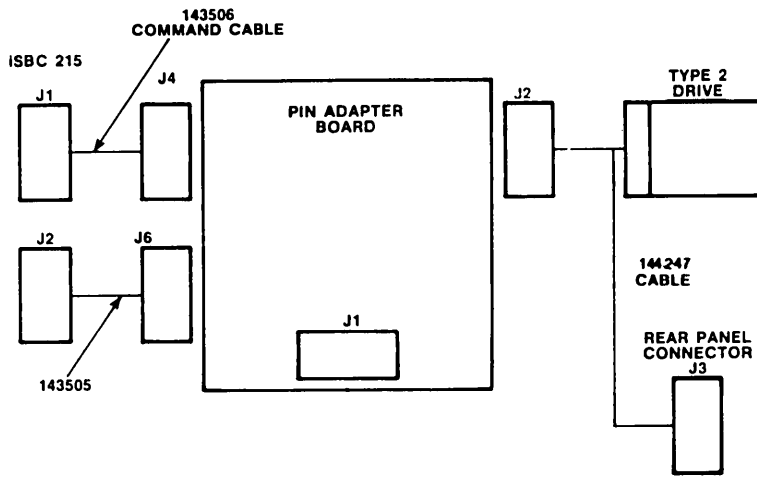
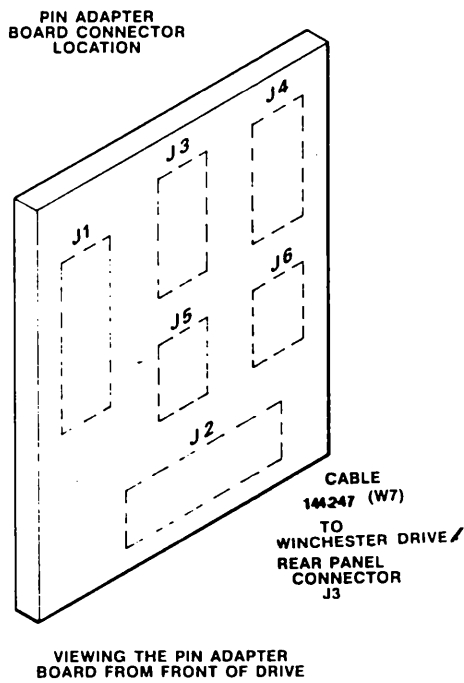

Figure 6-13. Winchester Drive Cable Interconnection



NOTE:
The connectors are not visible from this view.

Figure 6-14. Pin Adapter Board Connector Locations

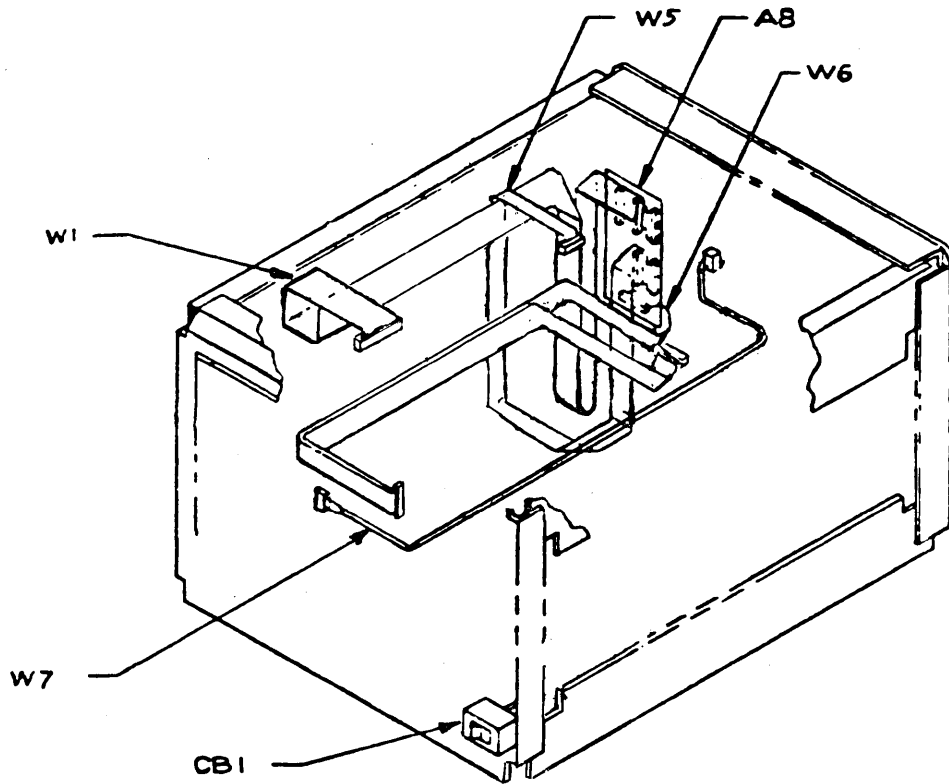

Figure 6-15. Priam Drive Cable Routing

MAINTENANCE DIAGRAMS

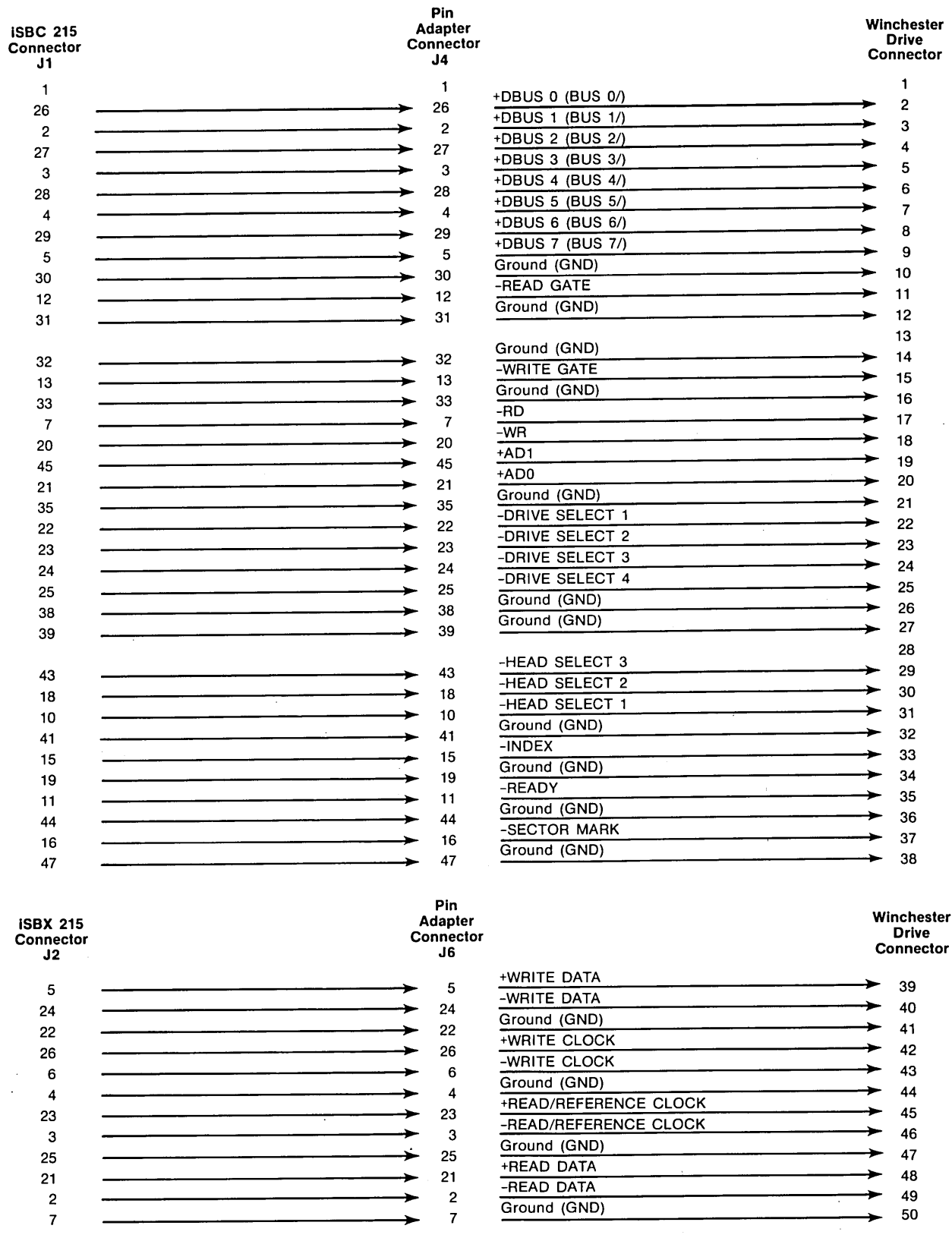

Figure 6-16. Priam Connector Pinout

MAINTENANCE DIAGRAMS

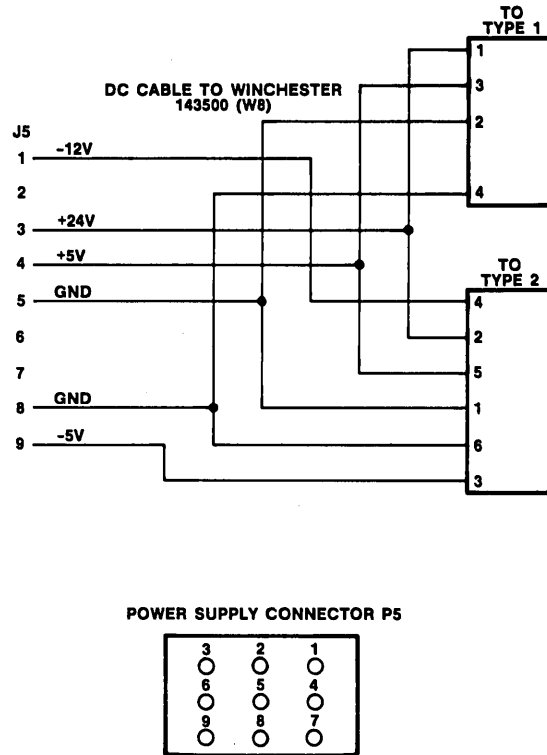

Figure 6-17. Priam DC Connector Pinout

MAINTENANCE DIAGRAMS

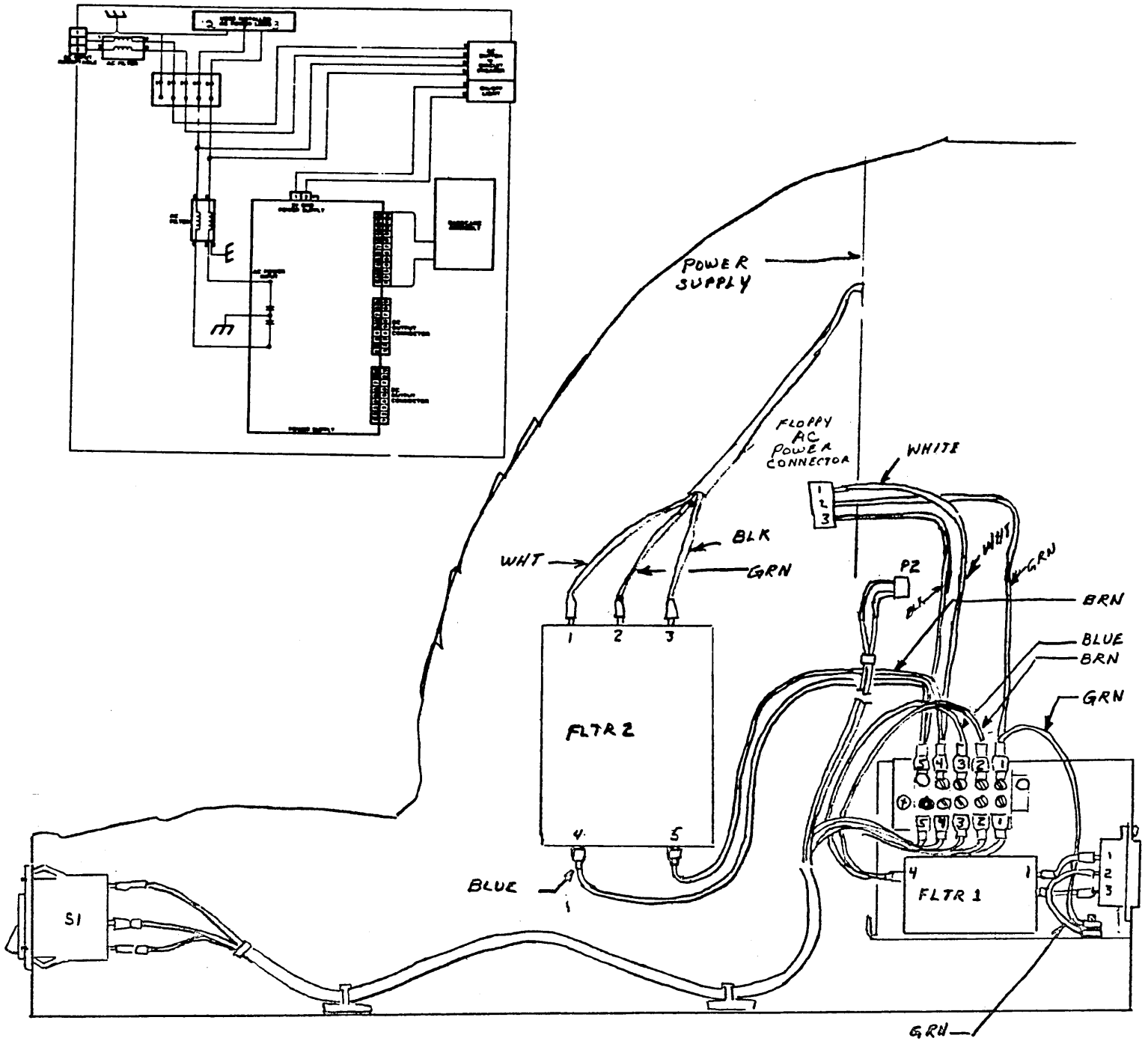

Figure 6-18. System 86/330 AC Wiring Diagram

APPENDIX A. INSTALLING ADDITIONAL WINCHESTER DRIVES

To install additional Winchester drives, proceed as follows:

1. Turn the AC power switch to off.

WARNING

Never attempt to service any sub-assembly within the chassis with the AC cord connected. Hazardous voltages are presented within the chassis with the AC cord connected to a power source.

2. Disconnect the AC power cord from the power source.
3. Remove the top cover. Refer to paragraph 4-7.
4. Remove the front panel. Refer to paragraph 4-6.
5. Remove the filler panel. Refer to paragraph 4-8.
6. Disconnect the power cable and the signal cable from the Winchester drive. Refer to Figure A-1.
7. Remove three screws securing the Winchester drive to the chassis. Refer to paragraph 4-10.
8. Slide the drive forward until the terminator and switch K6 are accessible.
9. Remove the terminator board from the Winchester drive.
10. Install the additional Winchester drive(s) into the selected chassis and connect to a power supply that supplies the rated power and voltage needed by the drives. Refer to paragraph 1-13 for Winchester drive power requirements.
11. Connect cable between connector J3 located at the rear panel of the chassis and signal connector on the added drive.

INSTALLING ADDITIONAL WINCHESTER DRIVES

12. Insert the terminator board into place on the last drive in the chain. Refer to Figure A-1.

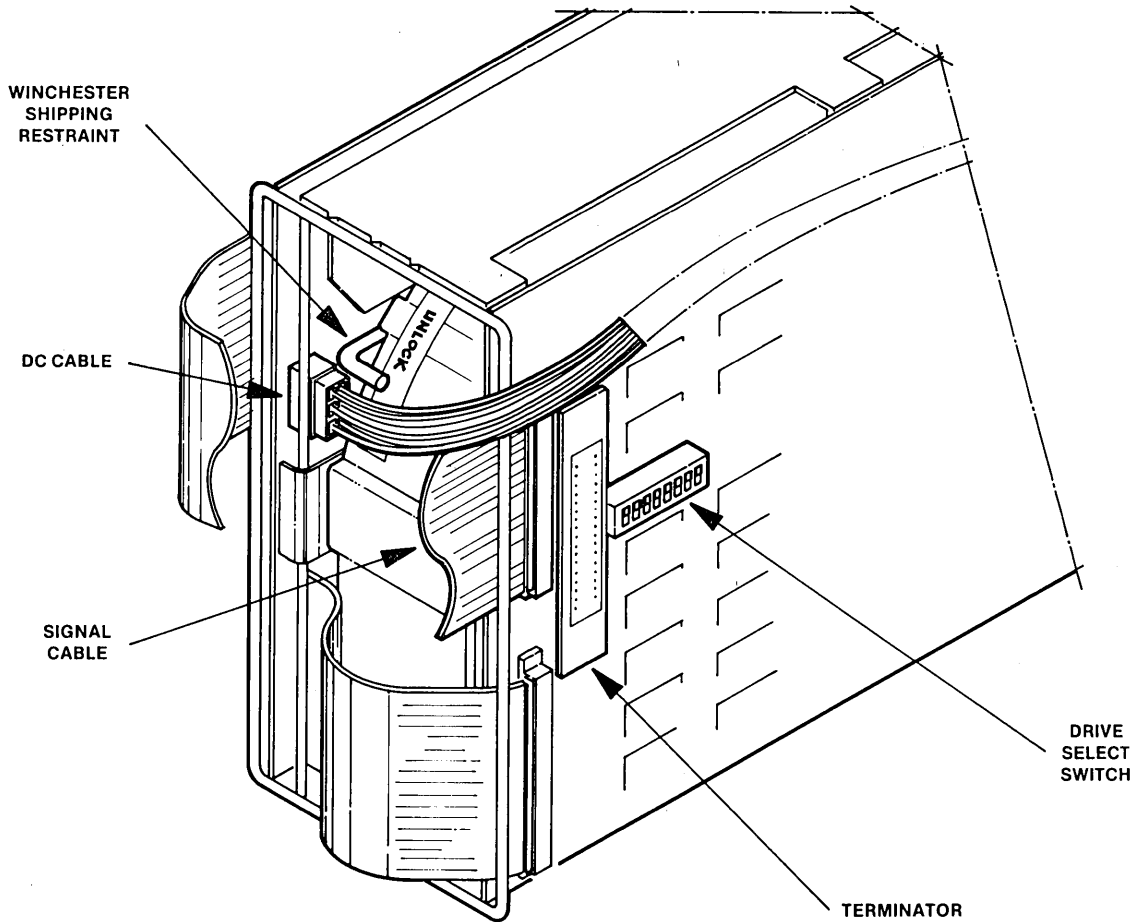

Figure A-1. Drive Select and Terminator Location

13. Position the unit select switch located at K6 on the circuit board of the Winchester drives for the appropriate unit select numbers. The unit select drive number is selected as follows:

Position	Drive Number
1-ON	1
2-ON	2
3-ON	3
4-ON	4

APPENDIX B. ADDING FLEXIBLE DISK DRIVES

To install additional flexible disk drives to the System 86/300, proceed as follows:

1. Turn AC power switch to off.

WARNING

Never attempt to service any sub-assembly within the chassis with the AC cord connected. Hazardous voltages are presented within the chassis with the AC cord connected to a power source.

2. Disconnect the AC power cord from the power source.
3. Remove the top panel and front bezel.
4. Remove three screws securing the flexible disk drive to the chassis.
5. Slide drive forward until the AC, DC, and signal cables are accessible.
6. Disconnect the AC, DC, and signal cables from the flexible disk drive.
7. Slide drive forward until the terminator and drive select jumpers are accessible. Refer to Figure B-1.
8. Remove the terminator IC pack install at location 5E.
9. Install the flexible disk drive into the selected chassis.
10. Connect cable between connector J4 located on the rear panel of the chassis and the flexible.

ADDING FLEXIBLE DISK DRIVES

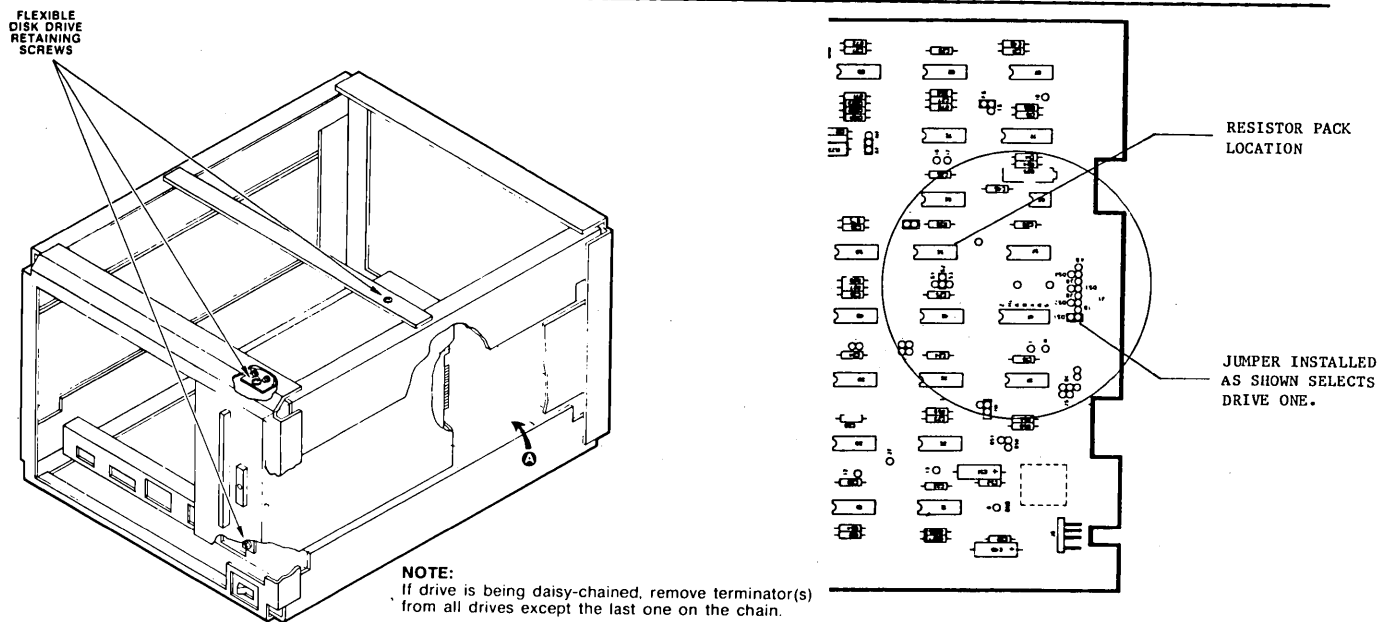

Figure B-1. Drive Select and Terminator Location

11. Reposition the drive select jumpers to configure the drives to the device numbers desired.
12. Install the terminator IC pack at location 5E on the last drive in the chain.
13. Reinstall drive into System 86/330 chassis.



REQUEST FOR READER'S COMMENTS

Intel Corporation attempts to provide documents that meet the needs of all Intel product users. This form lets you participate directly in the documentation process.

Please restrict your comments to the usability, accuracy, readability, organization, and completeness of this document.

1. Please specify by page any errors you found in this manual.

2. Does the document cover the information you expected or required? Please make suggestions for improvement.

3. Is this the right type of document for your needs? Is it at the right level? What other types of documents are needed?

4. Did you have any difficulty understanding descriptions or wording? Where?

5. Please rate this document on a scale of 1 to 10 with 10 being the best rating. _____

NAME _____ DATE _____

TITLE _____

COMPANY NAME/DEPARTMENT _____

ADDRESS _____

CITY _____ STATE _____ ZIP CODE _____

Please check here if you require a written reply.

WE'D LIKE YOUR COMMENTS . . .

This document is one of a series describing Intel products. Your comments on the back of this form will help us produce better manuals. Each reply will be carefully reviewed by the responsible person. All comments and suggestions become the property of Intel Corporation.



NO POSTAGE
NECESSARY
IF MAILED
IN THE
UNITED STATES

BUSINESS REPLY MAIL
FIRST CLASS PERMIT NO.79 BEAVERTON, OR

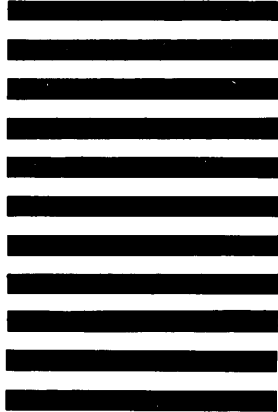

POSTAGE WILL BE PAID BY ADDRESSEE

Intel Corporation
5200 N.E. Elam Young Pkwy.
Hillsboro, Oregon 97123

O.M.S. Technical Publications



INTEL CORPORATION, 3065 Bowers Avenue, Santa Clara, California 95051 (408) 987-8080

Printed in U.S.A.