

129 **Card Data Recorder**/*Machine Description*

GA22-6980-1



129 Card Data Recorder/*Machine Description*

GA22-6980-1

Preface

This publication has been prepared primarily for the experienced operator of the IBM 29 Card Punch and the IBM 59 Card Verifier. It is designed to be used as a reference document at the operator position of the IBM 129 Card Data Recorder.

This description briefly defines the machine characteristics, capabilities, and special features. In addition, it contains operating information and procedures.

Second Edition (April 1971)

This is a major revision of, and obsoletes, GA22-6980-0. This manual should be reviewed in its entirety. Changes are continually made to the specifications herein; any such changes will be reported in subsequent revisions.

Requests for copies of IBM publications should be made to your IBM representative or to the IBM branch office serving your locality.

This manual has been prepared by the IBM Systems Development Division, Product Publications, Dept. B98, PO Box 390, Poughkeepsie, N.Y. 12602. A form for readers' comments is provided at the back of this publication. If the form has been removed, comments may be sent to the above address. Comments become property of IBM.

© Copyright International Business Machines Corporation
1970, 1971

Notes:

1. This document describes the Model 3 (punch-print-verify) machine, which has a single combination punch/read station. The Model 1 also has a combination station. Initial Model 2 machines (punch-print) have a separate punch station and read station, similar to the IBM 29 Card Punch. Model 2 machines with serial numbers 2xxxx and higher will have a single combination punch/read station, the same as the Model 1 and 3 machines.

All operations are the same on all Model 2 machines, whether they have the separate read and punch stations or the combination punch/read station.

2. This document states that column indicator shows CC when a correction card should be punched in verify mode on Models 1 and 3. (See "Column Indicator," "VER CORR (Verify Correction) Key," "Verify a Card," and "Punch a Verify Correction Card.") This CC indication will *not* be available on initial shipment Model 1 and 3 machines; it will be provided on machines with serial numbers 2xxxx and higher.

On initial Model 1 and 3 machines, without the CC indication, column indicator will show 00 for the preceding situation. *All operations are the same for all machines*; only the indication on the column indicator is different.

Contents

Introduction	4	CLEAR Switch (Momentary Spring Loaded)	9	Operating Procedures	18
Standard Features	4	REC BKSP (Record Backspace) Pushbutton	9	Power On	18
Special Features	4			Store a Program (Program Load)	18
Data Storage	5			Punch Out a Program	19
				Punch a Card	19
Operating Features	6	Keyboard Controls	10	Read Data	20
Column Indicator	7	Keyboard	11	Verify a Card	20
Card Release Pushbutton	7	FEED (Card Feed) Key	11	Punch a Verify Correction Card	21
Punch/Read and Eject Stations	7	REG (Register) Key	11	Add a Punch	21
Card Stacker	7	SKIP Key	11	Repunch (Make Over) a Card	22
Card Count Scale	7	REL (Release) Key	11	Replace the Ribbon (Models 2 and 3)	22
Stacker Stop Switch	7	Data Keys (Alpha, Numeric, Special Character, Space)	12	Remove a Card Jam	24
Card Hopper	7	PROG SEL (Program Select) Key	12	Card Information	24
Print Unit	7	ALPHA (Alphabetic Shift) Key	12	Acoustic Cover	24
Combination Punch/Read Unit	7	NUMERIC (Numeric Shift) Key	12	Keyboard Lockup Recovery	24
Keyboard Console	7	CHAR BKSP (Character Backspace) Key	12		
Keyboard	7	FIELD/WORD BKSP (Field/Word Backspace) Key	13	Special Features Summary	26
Chip Box	7	MULT PCH (Multiple Punch) Key	13	Production Statistics	26
Mainline Switch	7	VER/DUP (Verify or Duplicate) Key	13	Keystroke Counter	26
		BLANK COLUMNS/LEFT ZERO CTRL (Control) Key	13	Card Counter	26
Console Controls	8	VER CORR (Verify Correction) Key	14	Verify Correction Keystroke Counter	26
Keyboard Console	8	VER RES (Verify Reset) Key	14	Punchout Procedure	27
PUNCH/VERIFY Switch (Models 1 and 3)	8			Accumulate	28
Column Indicator	8			Additional Accumulate Program Levels	29
AUTO SKIP/DUP Switch	9			Self-checking Number Device	30
VERIFY Light	9			Modulus 10	30
REC ADV (Record Advance)/CARD FEED Switch	9			Modulus 11	30
PROGRAM MODE (Rotary Dial) Switch	9			Direct Punch Control	31
PRINT Switch (Models 2 and 3)	9	Graphics and Card Codes	15	Verify Read Control	32
CHARACTER MODE Switch	9	Program Card Codes	15	Extended Reading Board	32
READ Pushbutton	9	Card Visibility and Printing	16	Expansion Feature	32
		Data Card Codes and Graphics	17	Index	33

Introduction

The IBM 129 Card Data Recorders are key-entry, card punching and verifying machines with both data and program storage used to prepare standard 80-column cards for data processing.

The IBM 129 Card Data Recorders are available in three models:

Model 1: Punch	--	Verify
Model 2: Punch	Print	--
Model 3: Punch	Print	Verify

STANDARD FEATURES

- Two 80-position storage units plus program storage.
- Key data simultaneously with auto functions.
- Six program levels plus "no format" level.
- Keyed input error correction and correction punching.
- Immediate error correction and correction punching during verification (Models 1 and 3).
- Character, field, word, and record backspace.
- Automatic left-zero or left-blank insertion.
- Program read-in and punchout.

- Data read for duplicating and card makeover.
- A 48/64-character keyboard mode switch.
- A 29 type interlocked keyboard.
- Column indicator located on keyboard.
- A 64-character set for printing (Models 2 and 3).
- ASCII graphics available for keyboard and printing.

SPECIAL FEATURES

The following special features are described under "Special Features Summary":

- Production Statistics.
- Accumulate.
- Additional Accumulate Program Levels.
- Self-checking Number Device (Modulus 10 or 11).
- Direct Punch Control.
- Verify Read Control.
- Extended Reading Board.
- Expansion Feature.

DATA STORAGE

The 129 Card Data Recorder contains input and output sections of data storage. Each storage section can store 80 characters or columns of card information recorded in electronic form. Data keyed for punching is stored (recorded) in input storage. The column indicator shows the input storage position where the next character is to be recorded. If a character is keyed incorrectly, the machine can be backspaced and the correct character can be keyed. Rekeying erases the incorrect character in input storage and records the corrected character. After a card data record is complete in input storage, it is transferred to output storage and then punched in a card. While the card is being punched from output storage, the next card record can be keyed into input storage. (See Figure 1.)

For duplicating, data from the record in output storage is transferred to input storage and becomes part of the input record.

In a verify operation, the punched card to be verified is read into input storage, and the keyed data is compared with the data read into input storage. Errors can be corrected in input storage by a correction routine, and a correction card can be punched immediately after completion of each record verification. For verify duplicating, data in output storage is compared with data in input storage.

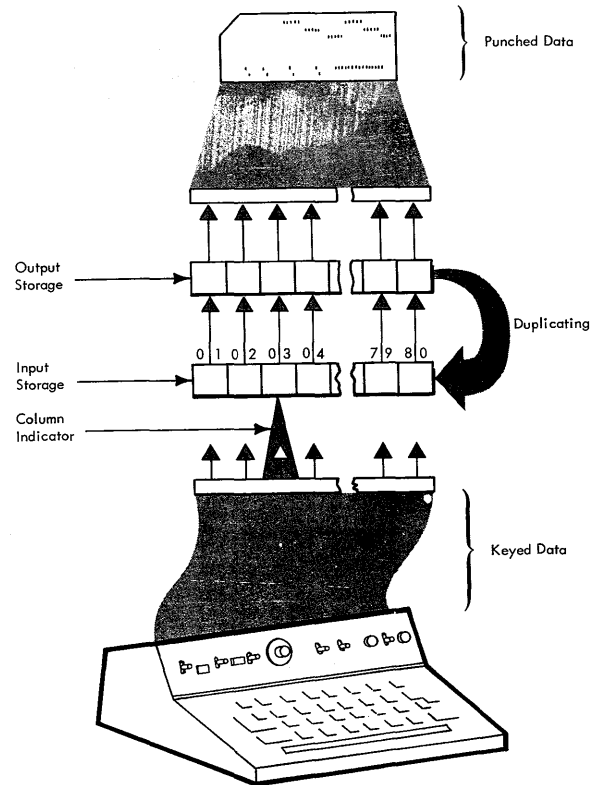

Figure 1. Input and Output Storage

Operating Features

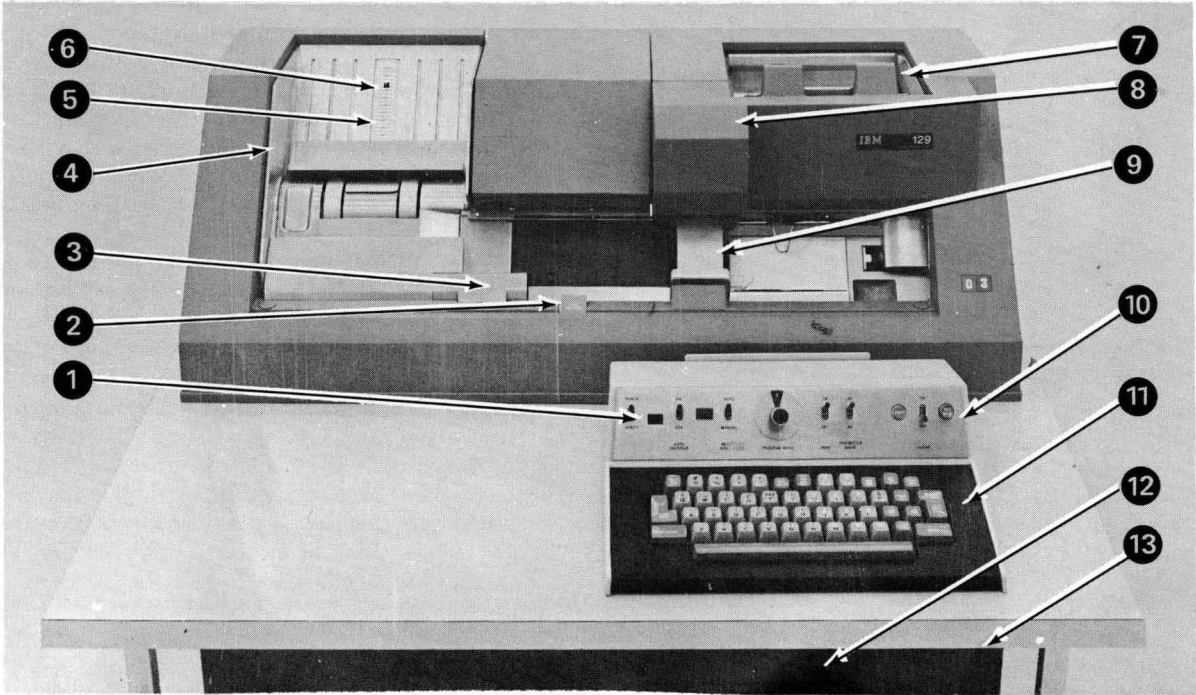

Figure 2. IBM 129 Card Data Recorder Model 3 (Punch-Print-Verify)

See Figure 2 for location of following components.

1 COLUMN INDICATOR

The column indicator, on keyboard console, shows next card column to be keyed. Refer to this indicator as a guide for spacing or backspacing to a particular column.

2 CARD RELEASE PUSHBUTTON

The card release pushbutton permits manual removal of a card from punch/read station.

3 9 PUNCH/READ AND EJECT STATIONS

Models 1 and 3 (verify capability) have a **9** combination punch/read unit at punch station, and only a card eject mechanism at the unused read location. Initial Model 2 machines have a separate **9** punch and **3** read station; later Model 2 machines have the combination punch/read station.

4 CARD STACKER

5 CARD COUNT SCALE

6 STACKER STOP SWITCH

The card stacker holds approximately 500 cards and has a convenient **5** card count scale. A full stacker operates a **6** stacker stop switch that interlocks the card feed. However, power is not turned off and operation may continue when cards are removed from stacker.

7 CARD HOPPER

The card hopper holds approximately 500 cards. Cards are placed in the hopper, in front of sliding pressure plate, face forward, with 9-edge down.

8 PRINT UNIT

The 64-character set print unit is only on Models 2 and 3.

9 COMBINATION PUNCH/READ UNIT

10 KEYBOARD CONSOLE

The keyboard console contains operating switches and controls.

11 KEYBOARD

The keyboard contains keys for a 64-character set and for control of machine. The keyboard pivots for convenience.

12 CHIP BOX

The chip box is under the desk top below the keyboard, and it should be emptied daily.

13 MAINLINE SWITCH

The mainline switch is on front right-hand side of cabinet under the keyboard. When mainline switch is turned on, machine is ready for use, in program level 0. When this switch is turned off, all programs and data are reset to blanks.

Console Controls

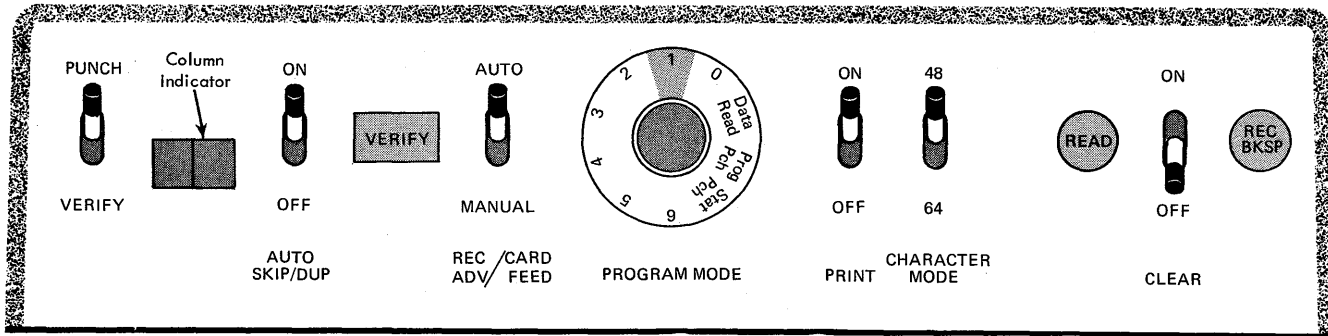

Figure 3. Keyboard Console

KEYBOARD CONSOLE

See Figure 3 for location of following controls and indicators.

PUNCH/VERIFY Switch (Models 1 and 3)

When PUNCH/VERIFY switch is set to PUNCH, machine operates as a punch. When PUNCH/VERIFY is set to VERIFY, machine operates as a verifier. This switch should be set only when card bed is clear and column indicator shows 01.

Column Indicator

The column indicator shows the position of input storage that will receive the next character. Column indicator shows 00 when REC ADV/CARD FEED is set to MANUAL and input buffer is complete; shows 88 when a field or record must be reverified in verify mode; shows CC when correction card should be punched in verify mode; and advances to 01 of next record when REC ADV/CARD FEED is set to AUTO, or when at 00 and manual program selection is made.

AUTO SKIP/DUP Switch

When AUTO SKIP/DUP is ON, programmed auto skip/dup fields operate automatically at electronic speeds. Auto duplication of blanks does not stop the function. When this switch is OFF, fields operate as manual fields. (Switch should be OFF for first record after clear operation, or if data has *not* been keyed or read into output storage.)

VERIFY Light

VERIFY light indicates verify error on verify models, and/or self-check error, if self-check feature is used.

REC ADV (Record Advance)/CARD FEED Switch

When REC ADV/CARD FEED is set to:

1. **AUTO**, machine advances from column 80 of one input record to column 01 of next input record, sets program level shown on PROGRAM MODE dial, stacks present card, and feeds next card.
2. **MANUAL**, machine stops at column 00 of current record. This allows manual program selection for next record or allows backspacing into present input record for correction of record before card is punched. Press FEED key if card feed is desired.

PROGRAM MODE (Rotary Dial) Switch

When PROGRAM MODE is set to:

1. 0-6, program level 0-6 is selected for next input record (when column indicator advances from 00 to 01) if REC ADV/CARD FEED is set to AUTO.

2. **DATA READ**, master card data enters output storage for duplication into following record.
3. **PROG PCH**, data from program storage is punched.
4. **STAT PCH**, totals for production statistics special feature are punched.

PRINT Switch (Models 2 and 3)

When PRINT is set to ON during keying into input storage, characters to be printed are the same as those punched in card. All leading 0's are print suppressed, except for units position of a field. Only 64-character set will print.

CHARACTER MODE Switch

When CHARACTER MODE is set to:

1. 64, the 64-character keyboard mode is selected.
2. 48, the 48-character keyboard mode is selected.

READ Pushbutton

When READ is pressed, program/data cards are read into storage, in conjunction with PROGRAM MODE dial.

CLEAR Switch (Momentary Spring Loaded)

When CLEAR is held ON, all cards move out of transport into stacker and column indicator returns to 01. Dup will not operate in first record following a clear operation.

REC BKSP (Record Backspace) Pushbutton

When REC BKSP is pressed, column indicator returns to column 01 of input storage without changing current program level, and any auto operation (skip/dup) programmed for column 01 is suspended.

Keyboard Controls

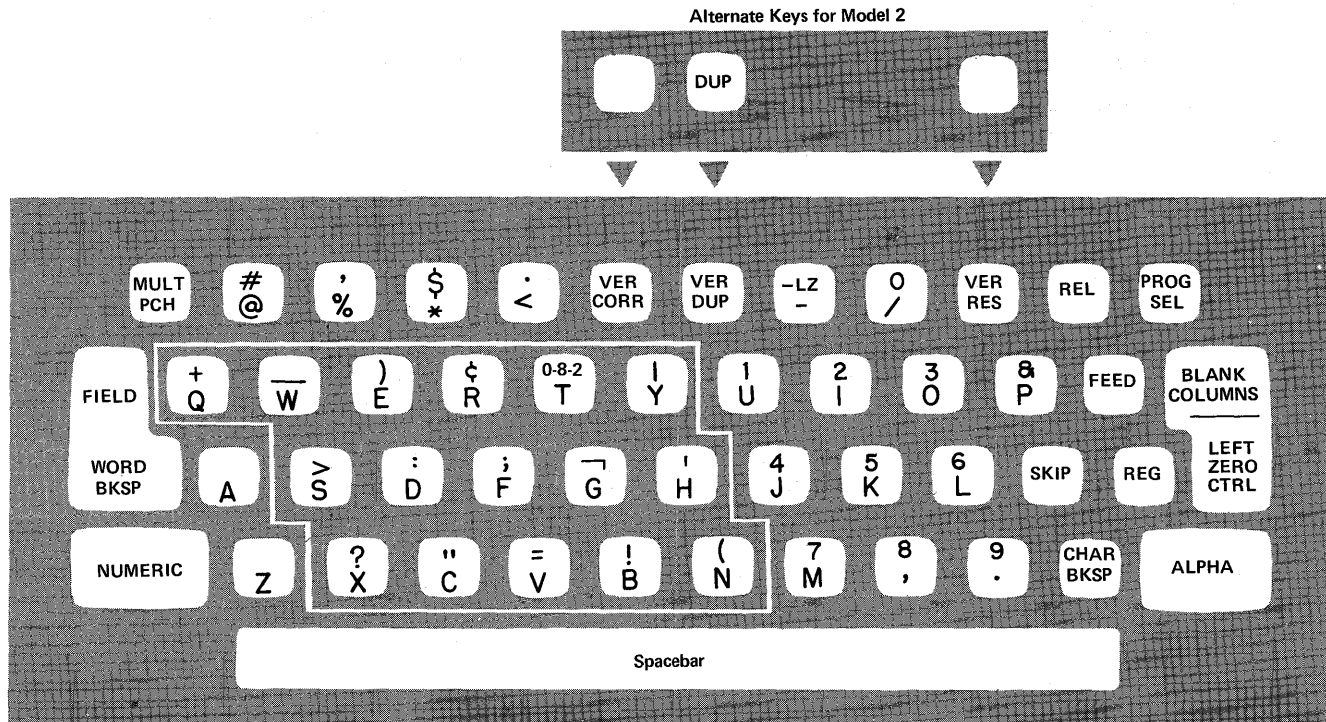

Figure 4. Keyboard Controls

KEYBOARD

See Figure 4 for location of following keyboard controls.

FEED (Card Feed) Key

Punch Mode: Holding FEED key down moves two cards from hopper into register and pre-register positions of punch station. Key is inoperative when a card is registered at punch station.

Verify Mode: Feeds one card from hopper. The card is read at punch/read station. Cards to be verified must be fed from hopper; they cannot be inserted manually.

REG (Register) Key

If a card is pre-registered or manually inserted, REG key registers the card at punch/read station. Pressing this key will not feed a card from hopper.

SKIP Key

Punch Mode: SKIP key initiates a skip to end of field definition. If no field definition or program is in level 0, this key provides a single space.

Verify Mode: Column in which SKIP key is pressed is verified to be blank, and a skip without following verification to end of that field is initiated. If column is punched, a

verify error is signaled. In a programmed LZ (left-zero) verify field, SKIP key is operative only as the first keystroke.

REL (Release) Key

Punch Mode: REL key moves column indicator through column 80, and space codes are written in input storage. The column indicator advances to column 00 if REC ADV/CARD FEED is set to MANUAL, or advances to column 01 of next record if REC ADV/CARD FEED is set to AUTO. Fields programmed for auto dup beyond point of release are duplicated if AUTO SKIP/DUP is ON.

Verify Mode: With REC ADV/CARD FEED set to AUTO, pressing REL key causes card to be released without verification and without OK punches in column 81, card is stacked, and next card is fed. With REC ADV/CARD FEED set to MANUAL, pressing REL key moves column indicator to column 00 to await operator action. (Use manual program selection and then FEED key, or set REC ADV/CARD FEED to AUTO, or use CLEAR switch to continue verify operation.) Fields programmed for auto verify beyond point of release are verified if AUTO SKIP/DUP switch is ON. Once released, a card cannot be OK-punched in column 81 (2-3 punch) unless again fed from the hopper and reverified.

Data Keys (Alpha, Numeric, Special Character, Space)

Depression of one of data keys enters a character into input storage for punching, or compares it with input storage for verifying. Alpha or numeric shift is determined by program or manual control. [The -LZ key has a special use for left-zero fields; see "BLANK COLUMNS/LEFT ZERO CTRL (Control) Key."] The special characters in the outlined area (Figure 4) are active only in 64-character mode. *Note:* The dash (-) 11-punch is available only in alpha shift.

PROG SEL (Program Select) Key

Pressing PROG SEL key followed by a data key (0-6) shifts machine to program level selected. (Keyboard locks if other than 0-6 is selected.) Program level selection can be made any number of times during the keying of a record. On advancing to next record, program returns to level indicated by the setting of PROGRAM MODE dial, if REC ADV/CARD FEED is set to AUTO.

If REC ADV/CARD FEED is set to MANUAL (column indicator at 00), depression of PROG SEL key followed by a data key (0-6) selects that level for next input record, punches and ejects present card (does not feed a card), and advances column indicator to column 01 of next record, or to first manual column if an auto field is programmed at start of record and AUTO SKIP/DUP switch is ON. Press FEED key if card feed is desired.

ALPHA (Alphabetic Shift) Key

Pressing ALPHA key shifts keyboard into alpha mode, as long as key is held down. When this key is released, machine returns to shift indicated by program.

NUMERIC (Numeric Shift) Key

Pressing NUMERIC key shifts keyboard into numeric mode, as long as key is held down. The numeric shift key must be held down when operating in program level 0 and numeric keying is required. It is used to override alpha programming when under program control. If both NUMERIC and ALPHA shift keys are pressed, numeric shift takes precedence.

CHAR BKSP (Character Backspace) Key

Each depression of CHAR BKSP key causes one manual column of backspacing, or unlocks keyboard (without a character backspace operation) if keyboard was locked due to an invalid key depression. When used after an error in verify mode, *before* rewrite, it resets the error condition and allows additional verify attempts of character in question. When used *after* rewrite, it allows reverification of rewritten character. *Note:* Character backspace will not reset a program select condition after PROG SEL key has been pressed. Either complete the selection or use FIELD BKSP key to reset program select condition.

FIELD/WORD BKSP (Field/Word Backspace) Key

A depression of FIELD BKSP key returns column indicator to first column of field being keyed. If in first column of a field, pressing this key returns column indicator to start of previous manual field.

The FIELD BKSP key operates as a word backspace key when used in conjunction with the ALPHA shift key. Pressing ALPHA shift key and FIELD BKSP key returns column indicator to column following last space that was spacebar entered, or to first column of a manual field, whichever comes first. Any backspace key (character, field/word, or record) may be used to unlock a locked keyboard. Backspace does not change the current program level.

MULT PCH (Multiple Punch) Key

Pressing MULT PCH key places keyboard in numeric shift and prevents column indicator from advancing while individual codes are keyed. If multiple punch special character is not one of standard 64 characters, printing is suppressed.

VER/DUP (Verify or Duplicate) Key

VER/DUP key is used to duplicate or verify a column or field of data from previous record in output storage. This key is inoperative unless data has been keyed or read into output storage. When this key is held down, it repeats the function at a rate of 10 fields/second in program levels 1-6, or 10 columns/second in program level 0.

Verify Mode: In a left-zero programmed field, it must be the first key pressed in the field; this key is inactive in any other position of the field.

BLANK COLUMNS/LEFT ZERO CTRL (Control) Key

Punch Mode: Pressing LEFT ZERO CTRL key, after a character or characters for a field are keyed, starts a left-zero (fill) operation if keyboard is in numeric shift or starts a left-blank (fill) operation if keyboard is in alpha shift. This key is not operative in first position of any field.

Use -LZ key for minus over units position and start LZ fill operation combined. For filled field (all digits, no 0's), use "MULT PCH (Multiple Punch) Key" procedure for minus over units position. Maximum length of a single LZ field is 79 positions.

Verify Mode: In any field, pressing BLANK COLUMNS key verifies blanks until a character or end of a field is reached.

In units position of a programmed left-zero field, this key only performs left-zero control function. This key must be pressed after verification of units position of field; otherwise, keyboard lockup occurs. Use -LZ key after units position verification for minus over units position verify and LZ control operation combined.

VER CORR (Verify Correction) Key

Verify Mode Only: Pressing VER CORR key in any field allows a rewrite of balance of field; pressing this key after a record backspace operation allows rewrite of the complete record. The keyboard locks (column indicator shows 88) and field or record must be reverified.

At completion of record verify operation, if any rewrite correction has been made by use of "VER RES (Verify Reset) Key" procedure or "VER CORR (Verify Correction) Key" procedure, machine locks with column indicator showing CC. CC indicates that a correction card should be punched. Manually insert a blank card in punch station and press VER CORR key to punch out corrected card.

VER RES (Verify Reset) Key

Verify Mode Only: Pressing VER RES key resets a verify error condition and allows a second verify attempt. If verify error is signaled again, reset is performed and third keystroke rewrites storage with the new character. After rewrite, perform character backspace and reverify; otherwise, machine will lock at end of field (column indicator shows 88) and require field backspace and reverification. (Character backspace may be used to interrupt error routine and allow additional verify attempts before rewrite.)

Graphics and Card Codes

PROGRAM CARD CODES

A program card, which is a basic part of program control, is prepared for each punching application. Proper punching in this program card controls automatic operations for corresponding columns of data cards being punched or verified. Each row in program card governs a specific function. (See Figure 5.)

Function	Punch Code	Field Location
<u>Standard Codes</u>		
Field Definition (FD)	12	All columns, except first column
Auto Skip Field	11	First column
Auto Dup/Auto Ver Field	0	First column
Alpha Shift (Programmed)	1	Each column for alpha shift
Left-zero Control Field (Verify Only)	3	First and last columns
<u>Special Feature Codes</u>		
Self-check Field	2	First and last columns
Add Accumulator A	5	First column
Add Accumulator B	6	First column
Add Accumulator C	7	First column
Punch Accumulator A, B, or C	4 + (5 or 6 or 7)	First column
Punch and Reset Accumulator A, B, or C	4 + 8 + (5 or 6 or 7)	First column
Direct Punch Control for "Buffered" Field	3	First column for direct punch mode only
Verify Read Control to Stop Verify Read Operation	11-0	Column desired to stop card

Figure 5. Program Codes

Notes for Figure 5:

1. Program codes apply in program levels 1-6. Program level 0 is 80 single-position fields, alpha shift.
2. If LZ control in units position verify is not desired, do not use 3-punch in units position.
3. Only field definition is required for LZ punching. Program cards coded for LZ in verify mode (3-punches) may be used in punch mode without alteration because machine ignores 3-codes in punch mode, unless direct punch control feature is used (see chart).
4. Minimum field size is two columns for accumulate, self check, and LZ.
5. Maximum field size is 79 columns for self check and LZ.
6. Maximum input field size for accumulate is 14 columns; maximum punchout field size is 19 columns.
7. A field may be programmed to add into any or all accumulators; punchout is limited to one accumulator per field.
8. Self-check fields may be adjacent. Self check and accumulate operate in both punch and verify mode. However, self check cannot be programmed in the same field as accumulate or left zero.
9. Verify read control (11-0 code) must not be programmed in same column as auto skip (11) or auto dup (0) codes, nor in any self-check programmed field.
10. Programs remain in storage until another program is read in to replace the original program, or until mainline switch is turned off, which resets programs 1-6 to blanks (equivalent to 80 single-position fields, numeric shift).

CARD VISIBILITY AND PRINTING

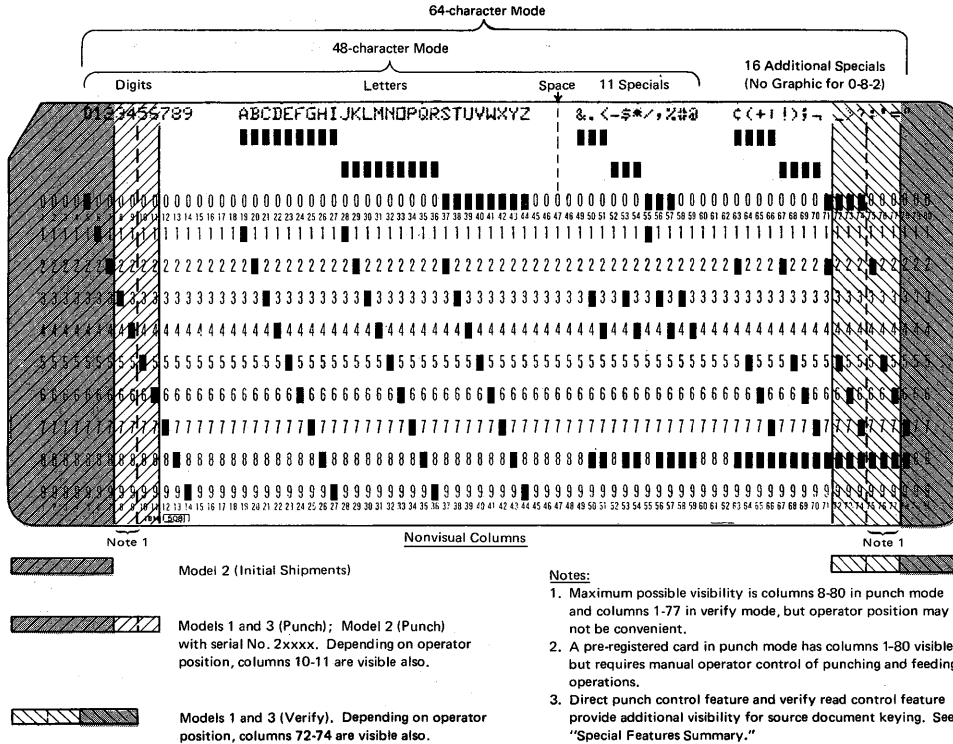

Figure 6. Card Visibility

DATA CARD CODES AND GRAPHICS

Figure 7 shows keytop graphics of 64-character set and related card codes for character set "EL."

Alpha Shift		Numeric Shift	
Graphic	Card Code	Graphic	Card Code
A	12-1	0	0
B	12-2	1	1
C	12-3	2	2
D	12-4	3	3
E	12-5	4	4
F	12-6	5	5
G	12-7	6	6
H	12-8	7	7
I	12-9	8	8
J	11-1	9	9
K	11-2	€	12-8-2 †
L	11-3	.	12-8-3
M	11-4	(12-8-5 †
N	11-5	+	12-8-6 †
O	11-6		12-8-7 †
P	11-7	!	11-8-2 †
Q	11-8	\$	11-8-3
R	11-9)	11-8-5 †
S	0-2	;	11-8-6 †
T	0-3	⌋	11-8-7 †
U	0-4	0-8-2	0-8-2 †
V	0-5	(keytop only)	
W	0-6	,	0-8-3
X	0-7	—	0-8-5 †
Y	0-8	>	0-8-6 †
Z	0-9	?	0-8-7 †
/	0-1	:	8-2 †
.	12-8-3	#	8-3
<	12-8-4	'	8-5 †
*	11-8-4	=	8-6 †
,	0-8-3	"	8-7 †
%	0-8-4	&	12
@	8-4		
—	11		

Notes for Figure 7:

1. Dagger denotes 16 additional special characters that are only in 64-character set.
2. ASCII graphics are the same as the 64-character set, except:

12-8-2 is [
 11-8-2 is]
 0-8-2 is \

3. Squared alphabetic letter □ is standard, to distinguish it from numeric 0.
4. The 11-0 combination (minus over 0) will not print. The 11-1 through 11-9 (minus over digit) will print letters J-R.
5. Space is a blank column in both alpha and numeric shift.
6. Dash (—) 11-punch is available only in alpha shift.

Figure 7. Card Codes and Graphics

Operating Procedures

POWER ON

Setting the mainline switch to ON resets (erases) all stored programs and data, and selects program level 0 regardless of PROGRAM MODE dial setting.

Program level 0 control is 80 single-position fields (alpha shift). Program levels 1-6, at this time, are controlled as 80 single-position fields (numeric shift). Program selection is possible, although program levels 1-6 are identical, until programs are read into program storage.

Punching and verifying can be done under program level 0 or 1-6 control. However, the first operation normally performed, after power is turned on, is to store the programs desired in program levels 1-6.

New program cards may be punched before programs are loaded by using the "Punch a Card" procedure.

STORE A PROGRAM (Program Load)

The desired program cards must be read into program storage to allow program control to be active during keying:

1. Operate CLEAR switch if card bed is not clear.
2. Set AUTO SKIP/DUP to OFF.

3. Set PROGRAM MODE to desired program level (1-6).
4. Insert program card at punch/read station (punch or verify mode), or feed card one cycle from the hopper to the pre-register position (punch mode). Card must *not* be registered.
5. Press READ pushbutton.

Repeat steps 3-5 for each program card to be stored. Each program load operation reads program card data into selected program storage level, stacks card in stacker, and sets machine to column 01 of that program level. Programs remain in storage until a new program is read into that program level or until a power off/on operation resets them.

Note: In punch mode, up to six program cards may be placed in hopper, fed singly, and program loaded by repeating steps 3-5. Then set PROGRAM MODE dial, manually select desired program level, and set PUNCH/VERIFY switch to PUNCH or VERIFY to start operation.

PUNCH OUT A PROGRAM

To check that a particular program has been stored at a specified level, punch out the program on a blank card:

1. Operate CLEAR switch if card bed is not clear.
2. Set PUNCH/VERIFY switch to PUNCH.
3. Set AUTO SKIP/DUP to OFF.
4. Set REC ADV/CARD FEED to MANUAL.
5. Set PROGRAM MODE to PROG PCH.
6. Insert blank card at punch station, or feed blank card from hopper.
7. Press REG (registers a card).
8. Press REL (sets column indicator at 00).
9. Press PROG SEL followed by data key (1-6) for program level desired.

Punchout follows and card is ejected. If data key 0 is pressed after PROG SEL, a blank card results. Repeat steps 6-9 for each program to be punched out.

All program cards are automatically printed (Models 2 and 3) during program punchout operation regardless of PRINT switch setting. Program punchout may be done at any time. Machine is set to that program level at conclusion of program punchout.

PUNCH A CARD

This procedure applies for punching data cards or for punching program cards (before a program has been loaded), using either program level 0 or program levels 1-6.

When programs have been read into storage, card punching can begin under program format control:

1. Place blank cards in hopper.
2. Operate CLEAR switch if card bed is not clear.
3. Set PUNCH/VERIFY switch to PUNCH.
4. Set AUTO SKIP/DUP to OFF.
5. Set REC ADV/CARD FEED to AUTO.
6. Set PRINT to ON/OFF, as desired.
7. Set CHARACTER MODE to 48/64, as desired.
8. Press FEED key (feeds two cards).
9. Set PROGRAM MODE to desired program level (1-6 or 0). Manually select desired program level by pressing PROG SEL followed by data key 1-6 or 0 (first record only).
10. Key first card record manually. Duplicating is not active and skipping is under manual control for first card. After first record has been keyed:
11. Set AUTO SKIP/DUP to ON.

On following records, programmed duplicating and skipping are performed automatically, and program level selection at start of each record is automatic, under control of PROGRAM MODE dial. Any field programmed for manual entry may be manually keyed, duplicated from last record, or skipped by manual operation. If an error is made in keying, a backspace-rewrite operation is required.

READ DATA

During this operation, a data card is read into output storage, to be used for new "master" card data for duplication into the following record:

1. Operate CLEAR switch if card bed is not clear.
2. Set PROGRAM MODE to DATA READ.
3. Insert data card at punch/read station (punch or verify mode), or feed card one cycle from hopper to pre-register position (punch mode). Card must *not* be registered.
4. Press READ pushbutton.

The machine is automatically set to program level 0 (alpha shift) and card is stacked. Continue desired operation after setting PROGRAM MODE dial, and manually selecting proper program level. Data from the data read operation cannot be punched out from output storage, except by duplication into following record.

VERIFY A CARD

Verify procedures are normally performed under program control:

1. Place cards to be verified in card hopper.
2. Operate CLEAR switch if card bed is not clear.
3. Set PUNCH/VERIFY switch to VERIFY.
4. Set AUTO SKIP/DUP to OFF.

5. Set REC ADV/CARD FEED to AUTO.
6. Set PRINT to ON/OFF (affects correction punched cards only).
7. Set CHARACTER MODE to 48/64, as desired.
8. Press FEED key (feeds one card). The first card is read and stored in input storage.
9. Set PROGRAM MODE to desired program level (1-6 or 0). Manually select desired program level by pressing PROG SEL followed by data key 1-6 or 0 (first record only).

Begin verify operation by keying first record from source document. Duplicating is not active and skipping is under manual control for the first verify record. After first record has been verified:

10. Set AUTO SKIP/DUP to ON.

On following records, programmed verify duplicating and skipping are performed automatically, and program level selection at start of each record is automatic, under control of PROGRAM MODE dial.

At completion of keying, if no errors exist, a 2- and a 3-punch are punched in column 81 of original card to signify an OK verify without errors. If column indicator shows 88, a field (or record) must be reverified. If column indicator shows CC, a correction card should be punched. Refer to "VER RES (Verify Reset) Key" and "VER CORR (Verify Correction) Key" descriptions under "Keyboard Controls" for error correction routines.

PUNCH A VERIFY CORRECTION CARD

This procedure is used during verify mode operation to punch a verify correction card after a verify record has been corrected in input storage. The column indicator shows CC for card correction:

1. Insert blank card at punch station. Card must *not* be registered.
2. Press VER CORR.

The card is registered and punched with corrected data. Only a 2-punch is punched in column 81 to signify that a correction was made during verify operation. The error card has no punches in column 81 and may be discarded. The following card is fed and read; verification continues.

Note: If correction card punching is not desired, use FEED or CLEAR, and continue verify operation. The FEED key allows manual or auto dup in following record. The CLEAR key prevents dup in following record. The error card is stacked with no punches in column 81.

Once a rewrite has been done in verify mode or record has been released, column 81 is not punched in original card. If it is desired to have column 81 punched (because of verify operator error, and card is correct as originally punched), card must be inserted in hopper, fed, and then verified without error.

ADD A PUNCH

To add a punch to an existing punched card, because repunching (makeover) of original card is not desirable, proceed as follows:

1. Operate CLEAR switch if card bed is not clear.
2. Set AUTO SKIP/DUP to OFF.
3. Set REC ADV/CARD FEED to MANUAL.
4. Set PRINT to ON/OFF, as desired.
5. Space or manually skip in input storage to desired column.
6. Key only added character or characters. Use manual alpha or numeric shift if shift of program level is not known.
7. Press REL (column indicator advances to 00).
8. Register the existing punched card at punch station.
9. Set REC ADV/CARD FEED to AUTO.

The punched card will be "overpunched" with spaces in all columns, and desired added punch(es) will be punched in column(s) in which it was keyed.

An alternate procedure would be to data read a blank card, manually dup to desired column, key the data, release, and proceed to step 8.

REPUNCH (MAKE OVER) A CARD

Repunching a card that must be altered or corrected by changing existing punches is done as follows:

1. Perform "Read Data" procedure with the punched card. (machine is automatically in program level 0, alpha shift.)
2. Set REC ADV/CARD FEED to AUTO.
3. Set PRINT to ON/OFF, as desired.
4. Manually dup up to column(s) requiring a change or correction, key the correction, then manually dup balance of the card.
5. Register a blank card at punch station, and card is then punched with original and corrected data.

REPLACE THE RIBBON (MODELS 2 AND 3)

The print ribbon feeds between **A** **N** two spools, through **D** **H** ribbon guides, and under **G** punch/read station, as shown in Figure 8. The old ribbon is removed and a new one is installed as follows:

1. Turn off mainline switch. (*Note: Punch out any production statistics or accumulate total(s) information before you turn power off because power off condition resets all totals to 0 and all programs and data to blanks.*)

2. Remove cover over print-feed unit.
3. Remove **P** ribbon-spool retaining clamp.
4. Cut or break the old **J** ribbon, then remove both **A** **N** spools from their **B** spindles and pull out the two pieces of ribbon. Empty one of the spools.
5. Place spool of new ribbon on **B** right-hand spindle; position spool so that ribbon feeds from top of spool toward the front of the machine. Lift up right end of **K** ribbon-reversing arm, if it is not already up, and unroll about 18 inches of ribbon; then push down right end of ribbon-reversing arm to hold spool steady.
6. Feed metal leading-end of the ribbon between **G** punch/read station and card bed, sliding it through groove in center of **F** card bed (between the 3 and 4 punching positions). The groove permits the extra thickness of the metal end and the **M** reversing eyelet to pass between punch die and card bed. Be sure to keep ribbon straight, with top side up at all times.
7. Hook metal leading-end of ribbon in slot in center of empty spool and wind ribbon onto spool until **M** reversing eyelet is on spool.
8. Place spool on left spindle; position it so that ribbon feeds onto spool over the top. Be sure that ribbon is not twisted and that top side of ribbon is still up.

9. Hook ribbon around **D** right and **H** left wire ribbon guides, and slide it through right and left ends of **K** reversing arm and over the **C** right and **L** left rollers in front of the ribbon spools.
10. Slide ribbon up under punch/read station so that it is in **E** upper groove provided for it in the card-printing position (above the 12 punching position), and take up the slack.
11. Replace **P** ribbon-spool retaining clamp.
12. Replace cover on print-feed unit.
13. Turn mainline switch on; machine operation can be resumed.

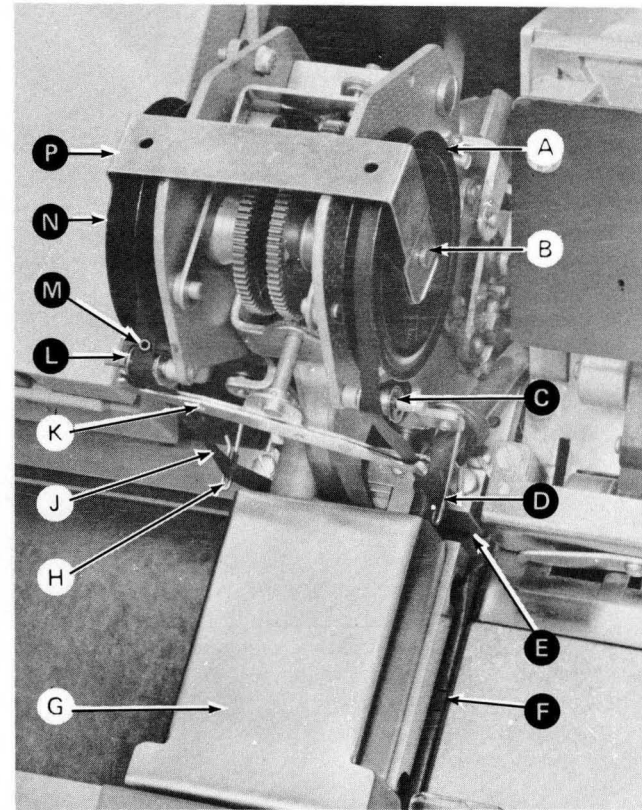

Figure 8. Ribbon Replacement

REMOVE A CARD JAM

The IBM 129 uses "fiber optics" in the read mechanism to provide high reliability and quiet operation. Card jams can normally be removed by pressing card release pushbutton and by pulling jammed card gently, or by pushing pieces of jammed card with another card.

Try to assemble jammed-card pieces together to be sure that all pieces have been removed and to facilitate makeover of the card. If all pieces cannot be removed, try the following procedure in punch mode:

1. Set PRINT and AUTO SKIP/DUP to OFF.
2. Set REC ADV/CARD FEED to MANUAL.
3. Remove any loose cards from card bed.
4. Manually select program 0. (Keyboard is in alpha shift.)
5. Key in all 80 columns, with &, -, and digits 0-9, sequentially.
6. Manually insert a card at punch station.
7. Press REG.
8. Press card release pushbutton; hold it down through step 9.
9. Manually select program 0. (Press PROG SEL, then data key 0.) Punchout follows; however, the card does not move while you press card release pushbutton.
10. Tear a strip of card about 1-inch wide and use it (or the special "type 129 card saw") to push out pieces of card which may still be under the punch.
11. Repeat this entire procedure, using DUP key for step 5. Do the procedure several times if pieces of card are still jammed.

Note: If card saw must be used, be sure to use *only* the special "type 129 card saw" that is included with every machine.

CARD INFORMATION

1. Cards with upper left or upper right corner cuts are acceptable although printing may be affected by size of cut.
2. Cards with lower corner cuts (except lower left corner cut C-3, 30-degree, 0.130-inch base measurement) cannot be fed.
3. Round corner cards are acceptable.

ACOUSTIC COVER

An acoustic cover for the card transport of the IBM 129 is available to provide further noise reduction, in addition to that resulting from the use of fiber optics sensing, electronic storage, and sound-reduced mechanical components. The cover is similar to the acoustic cover for the IBM 29/59 machine; it may be field installed.

KEYBOARD LOCKUP RECOVERY

The IBM 129 has several machine and keyboard interlocks to prevent invalid or erroneous operation, to detect potential errors, and to ensure accurate data during punch or verify operations. Recovery procedures are:

Punch or Verify Mode

Possible Causes

Invalid character key.

Attempted duplication after CLEAR.

Invalid program selection.

Hopper out of cards.

Stacker full.

Column indicator at 00, and REC ADV/CARD FEED set to MANUAL.

Punch Mode Only

Possible Causes

Attempt to key when input storage is full (may occur on records that have a small number of manual columns and remainder is auto skip or auto dup columns).

Recovery

Character backspace and rekey.

Character backspace and manually key in data.

Character backspace and select program levels 0-6.

Add cards and feed.

Remove cards and continue.

Set REC ADV/CARD FEED to AUTO, or manually select program and feed a card.

Recovery

Character backspace and continue after data in input storage has been transferred to output storage.

Verify Mode Only

Possible Causes

Compare error; VERIFY light ON.

Attempt to verify before first manual column has been read by machine. Keyboard will *not* accept keystroke.

Left-zero control error in units position of left-zero programmed field.

Failure to reverify a correction (column indicator at 88).

Recovery

Use VER RES and retry and/or correct.

Key only when first manual column has been read by machine.

Check for correct number of leading 0's in field; reverify or correct as required.

Field or record backspace and reverify.

If the preceding recovery procedures do not correct the lockup, use CLEAR and restart the operation, being sure to check switch settings and to follow the standard operating procedures. Check the program being used, via a program punchout operation, to be sure all programmed operations are valid. If special features are involved, check for correct programming and keying procedures. If lockup continues, ask your supervisor for assistance.

Special Features Summary

The following special features are available for the IBM 129 Card Data Recorder.

PRODUCTION STATISTICS

The production statistics feature provides statistics on card punch/verifier production for use in measurement of work load, analysis of errors, and job accounting. This feature provides a combination electronic counter package.

Keystroke Counter

This six-position counter (000,000 to 999,999) counts every data keystroke in punch and verify mode, and all functional keystrokes except: alpha, numeric, multipunch, feed, register, program select, dup, verify correction, and verify reset. It does not decrement; overflow rolls from 999,999 to 000,000.

Card Counter

This four-position counter (0000 to 9999) counts every output record in punch mode and every verify correct or correction punched card in verify mode. It does not count error cards in verify mode, program cards read in, and data cards read in. It counts program cards or accumulator total cards that are punched out. The counter does not decrement; overflow rolls from 9999 to 0000.

Verify Correction Keystroke Counter

This four-position counter (0000 to 9999) counts each verify correction rewrite keystroke in verify mode. It does not decrement; overflow rolls from 9999 to 0000.

Operation

All counting is done automatically under machine control, not under operator or program control. All counters may be punched out, or punched out and reset, under operator-keyboard control. Selective counter punchout is not possible. Indicative data (operator number, machine number, date, job, etc.) may be manually punched in columns 1-66 of the total card. These keystrokes are counted in keystroke counter, but total card is not counted in card counter.

Totals may be punched by batch, job, or day, etc. All counters are reset to 0 when machine power is turned off. This feature may be field installed.

Note: In verify mode, error cards, which are not counted in card counter, may be collected and counted separately and the number punched with other indicative data in the total card to provide additional data on errors per card, etc.

Punchout Procedure

Production statistics totals are punched in columns 67-80, under control of PROGRAM MODE and REL. Punchout is done by the operator as follows:

1. Set machine to punch mode. Set PRINT switch to ON, if desired.
2. Register a card; set REC ADV/CARD FEED switch to AUTO.
3. Key indicative information, as desired, in columns 1-66, using any desired program level (0-6).
4. In column 67, or prior:
 - a. Set PROGRAM MODE to STAT PCH.
 - b. Press REL to cause punchout *without* reset of statistics counters.
 - c. Press and hold NUMERIC shift and press REL to cause punchout *with* reset of statistics counters.

5. If a keystroke, other than REL, is made in column 67, production statistics will not be punched out when REL is pressed (although card will be punched with indicative data) unless appropriate backspace recovery to column 67 or prior is made before REL is pressed.
6. Punchout occurs as follows:

<i>Card Columns</i>	<i>Information Punched</i>
1-66	Indicative data or spaces
67-72	Keystroke counter total
73-76	Card counter total
77-80	Verify correction rewrite keystroke total.

7. Machine is in program level 0 at conclusion of punchout. Set PROGRAM MODE to desired home position, and manually select desired program level to continue operation.

ACCUMULATE (Requires Expansion Feature as Prerequisite)

The accumulate feature provides the ability to balance to a predetermined total, to create a hash total for a group of cards or a batch of work, or to crossfoot and punch totals in the same card or, in a following card, under program control.

Accumulate consists of three 14-position, individual accumulators that add any numeric manually keyed or duplicated fields, in punch or verify mode, into any accumulator, under program control. The maximum size of the input field is 14 positions, and any total beyond the 14th position will carry into the 15th position, and will maintain a valid total up to 19 positions. A minus accumulate condition occurs if an 11-punch is multi-

punched in units position. Amounts to be accumulated in punching can be entered only by keying or duplicating, not by a data read operation.

Operation

Accumulate arithmetic occurs only after entire record has been keyed; therefore, there are no restrictions on the use of any backspace functions during keying. Any field can be programmed to add into any or all accumulators.

In verify mode, only verified correct data is accumulated, and total fields are automatically verified for accuracy. An error in an automatically verified *total* field is indicated by AC on column indicator. The correction card that is punched will contain the correct totals based on all verified data.

Program control of the accumulator uses the 4-, 5-, 6-, 7-, 8-punches of the program card; accumulate control is active only in program levels 1 and 2 unless the "additional accumulate program levels" feature is also installed, which expands accumulate control to program levels 3-4-5-6.

Punchout, or punchout and reset, of individual accumulators are under program control, and may be done selectively. An accumulator can be programmed to punch out into any field or fields, if desired. Only one accumulator can punch at a time in any field. Group totals are normally punched out via a different program level than the accumulating program level. Maximum punchout field size is 19 positions. Credit totals are punched with an 11-punch over the units position.

In verify mode, a field programmed for auto skip and accumulate (11-punch and 5- or 6- or 7-punch) will automatically accumulate from the card.

Minimum field size is two positions. Accumulate and self check cannot be programmed in the same field. All accumulators are reset to 0 when machine power is turned off. (Not recommended for field installation.)

ADDITIONAL ACCUMULATE PROGRAM LEVELS

The accumulate feature is active only in program levels 1 and 2. The additional program levels feature provides the ability to program accumulate functions in program levels 3-4-5-6.

Accumulate is a prerequisite for "Additional Accumulate Program Levels." Additional levels may be field installed.

SELF-CHECKING NUMBER DEVICE (MODULUS 10 OR MODULUS 11)—Requires Expansion Feature as Prerequisite

A self-checking number consists of two parts: basic identifying number and its check digit. The check digit, derived from basic identifying number by a calculating technique, is always the units digit of the self-checking number. This feature assures that all digits of a number, such as an account or a part number, have been correctly keyed. Fields containing self-checking numbers can be any size up to 79 columns, including the check digit. More than one self-check field can be checked per card, and the fields may be adjacent. An 11-punch is punched in column 81 of the card to signify a valid self-checking number.

Modulus 10

Modulus 10 is designed to detect the incorrect keying of a single digit or a single transposition. It uses weighting factors 1, 2, 1, 2, which are automatically entered and calculated under machine control.

Modulus 11

Modulus 11 is designed to detect the incorrect keying of a single digit, a single transposition, and a double transposition. It uses weighting factors of 7, 6, 5, 4, 3, 2, which are automatically entered and calculated under machine control.

Operation

The self-check field is programmed with a 2-punch in both the high- and low-order field positions in addition to normal field definition. No other program codes are needed. Self-checking device operates in all six program levels. *Checking can be done in verify mode by manual keying or it can be done automatically* if the cards were punched on a machine without the self-checking device. Program the field for auto skip and self check (11-punch and 2-punch), and the self-check calculation will occur automatically.

Error procedures allow the operator to rekey a field if the self-check number does not check, or to overpunch the field to indicate an invalid number, or to skip the field and leave it blank. On Model 2 machines, a "SELF CHECK" indicator light is provided for error indication. On Model 1 and 3 machines, dual use is made of the VERIFY light for both verify and self-check error indication.

The high-order portion of a self-check field may be automatically duplicated, and the remainder of the field may be automatically skipped.

Self-checking numbers of Modulus 10 are not compatible with those of Modulus 11. Self-check number generation, self-check punch elimination, and left-based numbers are not available for Modulus 10 or 11. Self check cannot be programmed in the same field as left zero (LZ), nor in the same field as accumulate. (Not recommended for field installation.)

DIRECT PUNCH CONTROL

The direct punch control feature is available only on machines having serial number 2xxxx and higher.

On Model 1 and 3 machines, the PUNCH/VERIFY switch is expanded to a three-position switch with center position being "DIRECT PUNCH" position. On Model 2 machines, a switch is added to allow selection of punch or direct punch operation. When machine is in direct punch mode, each keystroke is punched directly into the card, and keying and card motion are synchronized. All program levels and functions are active in direct punch mode, except left zero and record backspace.

Direct punch is useful for source document punching jobs, where card design requires card motion similar to the 29 for full visibility during punching; it is also used for 29 simulation by untrained users and for card makeover or corrections, etc.

Operation

By program card control, individual fields may be keyed in a "buffered" mode, while balance of card is keyed in direct

punch mode. A 3-punch in first column of a field in direct punch mode causes that field to be "buffered" and left zero may therefore be used, and character backspace may be used for error correction. However, a backspace beyond the last column punched in the card is not possible. Adjacent fields may be programmed for "buffer" operation. Punching of the "buffered" field occurs when next direct punch column is punched.

Fields programmed for accumulate or self check will be automatically "buffered" in direct punch mode, regardless of programming. Production statistics counters count normally when direct punch is used. When column 35 is to be punched, columns 1-28 may be seen on left side of punch/read station, or columns 43-80 may be seen on right side of station, depending on operator position at keyboard.

The CLEAR switch is not operative for a card in direct punch mode. Do *not* perform program load, data read, program punchout, or production statistics punchout procedures in direct punch mode. This feature operates only in punch mode; it may be field installed.

VERIFY READ CONTROL

The verify read control feature is available only on Model 1 and 3 machines having serial number 2xxxx or higher. It is not available on Model 2 machines.

This feature facilitates operator reading of source document cards during verification, and allows verification of a source document similar to the IBM 59 procedure, without the need for card format redesign.

Operation

This feature operates only under program control. An 11-0 punch in the program card, in any desired column, will stop the machine from reading a card in verify mode, on the column in which the 11-0 is coded, before that column has been read for verification. (The column indicator shows the next column to be verified, regardless of the card position in the bed.)

If the card is stopped on column 35, by an 11-0 punch in column 35 of the program card, then columns 1-28 may be seen on the left side of the punch/read station, or columns 43-80 may be seen on the right side of the station, depending on operator position at keyboard. When column prior to the 11-0 code has been verified (column 34 in this case), reading again starts until the next 11-0 is read in the program.

All functions and operations remain the same when verify read control feature is used. Accumulate, self-check, and production statistics operate normally. The CLEAR switch is not operative until column 80 has been read for any card in which verify read control is used. [*Note:* Do not use 11-0 in column 1, nor in any column in which auto skip (11) or auto ver-dup (0) is programmed, nor in any self-check programmed field.] This feature operates only in verify mode; it may be field installed.

EXTENDED READING BOARD

The working area of the reading board may be increased by adding an extension measuring 11-1/2" x 12", to the front edge, left side of the standard reading board. This may be field installed.

EXPANSION FEATURE

The expansion feature does not provide a function by itself, but it is necessary to provide additional capacity in the machine to allow the installation of accumulate or self check. Only one feature is needed, whether accumulate or self check or both are installed. (Not recommended for field installation.)

Index

- accumulate feature 28
- acoustic cover 24
- additional accumulate levels feature 29
- ALPHA key 12
- AUTO SKIP/DUP switch 9

- backspace
 - character 12
 - field or word 13
 - record 9
- blank columns/left-zero control (BLANK COLUMNS/
LEFT ZERO CTRL) key 13
- buttons
 - card release 7
 - READ 9
 - record backspace (REC BKSP) 9
- card
 - code 17
 - counter feature 26
 - hopper 7
 - information 24
 - jam removal 24
 - printing 16
 - release pushbutton 7
 - saw 24
 - scale 7
 - stacker 7
 - visibility 16
- character backspace (CHAR BKSP) key 12
- CHARACTER MODE switch 9
- chip box 7
- CLEAR switch 9
- coding, program 15

- column indicator 7, 8
- controls
 - console 8
 - keyboard 10
- corner cut cards 24
- correction keystroke counter feature 26

- data keys 7, 10
- data read operation 20
- data storage 5
- direct punch control feature 31
- duplicate 9, 13

- eject station 7
- expansion feature 32
- extended reading board feature 32

- features
 - operating 6
 - special 4, 26
 - standard 4
- FEED key 11
- field/word backspace (FIELD/WORD BKSP) key 13

- graphics 17

- indicators, console 8

- jammed cards, removal 24

- keyboard 7, 10, 11
- keyboard console 8, 9
- keyboard console controls 10
- keyboard keys 11-14

keyboard lockup recovery 25
 keystroke counter feature 26

 left-zero key 13
 light
 column indicator 8
 VERIFY 9
 lockup recovery procedure 25

 machine components 7
 mainline switch 7, 18
 make over a card 22
 multiple punch (MULT PCH) key 13

 NUMERIC key 12

 operating procedures
 add a punch 21
 power-on 18
 punch a card 19
 punch a verify correction card 21
 read data 20
 repunch (make over) a card 22
 store a program 18
 verify a card 20

 PRINT switch 9
 print unit 7
 printing, card 16
 production statistics feature 26
 program card codes 15
 program load 18
 PROGRAM MODE switch 9
 program select (PROG SEL) key 12
 program storage 5
 punch and read stations 7
 punch mode 8, 11

PUNCH/VERIFY switch 8
 pushbuttons (*see* buttons)

 READ pushbutton 9
 record advance/card feed (REC ADV/CARD FEED) switch 9
 record backspace (REC BKSP) pushbutton 9
 recovery procedures 25
 register (REG) key 11
 release (REL) key 11
 ribbon replacement 22

 self-checking feature 4, 30
 SKIP key 11
 special features 4, 26
 stacker scale 7
 stacker stop switch 7
 standard features 4
 stations, eject and punch/read 7
 storage, input/output 5
 statistics punchout 27
 switches
 keyboard console 8
 mainline 7, 18
 stacker stop 7

 verify
 correction keystroke counter feature 26
 correction (VER CORR) key 14
 duplicate (VER DUP) 13
 error correction 14, 20
 light 9
 mode 8, 11
 OK punches 20
 reset (VER RES) key 14
 verify read control feature 32
 visibility, card 16, 31

 word backspace 13

.....CUT ALONG THIS LINE

READER'S COMMENT FORM

IBM 129 Card Data Recorder/Machine Description

GA22-6980-1

Your comments about this publication may be helpful to us. If you wish to comment, please use the space provided below, giving specific page and paragraph references.

Please do not use this form to ask technical questions about the system or equipment or to make requests for copies of publications; this only delays the response. Instead, make such inquiries or requests to your IBM representative or to the IBM Branch Office serving your locality.

Reply requested

Yes

No

Name _____

Job Title _____

Address _____

_____ Zip _____

WTC users must add postage.

YOUR COMMENTS, PLEASE

This manual is a reference source for systems analysts, programmers and operators of IBM systems. Your comments will help us produce better publications for your use. Each reply will be carefully reviewed by the persons responsible for writing and publishing this material. All comments and suggestions become the property of IBM.

Note: Please direct any requests for copies of publications, or for assistance in using your IBM system, to your IBM representative or to the IBM Branch Office serving your locality.

BUSINESS REPLY MAIL
NO POSTAGE STAMP NECESSARY IF MAILED IN THE UNITED STATES

FIRST CLASS
PERMIT NO. 419
POUGHKEEPSIE, N.Y.

POSTAGE WILL BE PAID BY

IBM CORPORATION
P.O. BOX 390
POUGHKEEPSIE, N.Y. 12602



ATTENTION: CUSTOMER MANUALS, DEPT. B98



International Business Machines Corporation
Data Processing Division
1133 Westchester Avenue, White Plains, New York 10604
(U.S.A. only)

IBM World Trade Corporation
821 United Nations Plaza, New York, New York 10017
(International)



International Business Machines Corporation
Data Processing Division
1133 Westchester Avenue, White Plains, New York 10604
(U.S.A. only)

IBM World Trade Corporation
821 United Nations Plaza, New York, New York 10017
(International)