

IBM Field Engineering Theory of Operation

29 Card Punch

Preface

This manual describes the mechanical and electrical principles of operation for the IBM 29 Card Punch including information for the wire contact relay machines. Also included is the information previously contained in Field Engineering Manual of Instruction, *IBM 29 Card Punch with Left-Zero Insertion*, Form 225-3386.

For detailed descriptions of machine functions, see *IBM 29 Card Punch*, Form A24-3332.

For adjustments and maintenance procedures, see the Field Engineering Maintenance Manual, *IBM 29 Card Punch*, Form 225-3357.

For information and maintenance procedures for the features of the IBM 29 Card Punch, including the Interpreting Card Punch, Model C, refer to Field Engineering Theory-Maintenance Manual, *IBM 29 Card Punch Features; 29 Interpreting Card Punch, Model C*, Form 223-2926.

It is assumed that the reader has little or no previous knowledge of the subject.

FIFTH EDITION (March, 1970)

This edition, Order Number S225-3358-4, is a reprint of Form 225-3358-3 incorporating changes released in the following FE Supplements:

FES NUMBER	DATE
SS23-4064	February 12, 1969
SS23-4066	May 1, 1969

Changes are periodically made to the information herein; any such changes will be reported in subsequent revisions or FE Supplements.

This manual has been prepared by the IBM Systems Development Division, Product Publications, Dept. B96, P.O. Box 390, Poughkeepsie, N.Y. 12602. A form for readers' comments is provided at the back of this publication. If the form has been removed, comments may be sent to the above address.

Contents

Chapter 1. Introduction	1-1	Circuit Card	2-34
Card Movement	1-1	Edge (SMS Card) Connectors	2-36
Punching and Reading Sequence	1-3	Standard Modular System (SMS)	2-36
Card Printing	1-4	Description	2-36
Card Hopper	1-4	SMS Card Receptacles	2-37
Card Feed, Detail Station, and Punch Station	1-4	SMS Locations and Pin Numbering	2-37
Master Station and Read Station	1-4	Wire Contact Relays	2-37
Eject Station	1-4	Printing Mechanics	2-38
Stacker	1-4	Print Wire Restoring Heads	2-40
Program Unit	1-4	Code Plate	2-40
Keyboards	1-6	Positive Code Plate Stops	2-42
Machine Wiring Diagram	1-6	Print Interposers	2-42
Location Chart	1-7	Punch Extensions and Code Plate Shifting	2-42
Card Feed and Punch: Mechanical Timing Charts	1-7	Print Pressure Plate	2-43
Cycles and Timings	1-7	Print Suppression Mechanism	2-44
		Print Character Pattern Chart	2-44
		Print Timing Chart	2-44
		Ribbon Feed	2-46
Chapter 2. Functional Units	2-1	Chapter 3. Principles of Operation	3-1
Continuously Running Mechanism	2-1	REED RELAY MACHINES	3-1
Drive Mechanism	2-1	Manual Punching Operation	3-1
Friction Clutch and Escapement Mechanism	2-2	Program Levels (Program 1 and Program 2)	3-1
Magnet and Clutch Assemblies	2-3	Error Reset	3-3
Card Feed Clutch	2-4	Feed Key	3-3
Escapement Magnet Assembly	2-4	Feed Key – First Depression	3-4
Punch Clutch Magnet Assembly	2-5	Feed Key – Second Depression	3-4
Card Feed Latch Magnet Assembly	2-5	Card-to-Card Skip (Auto Feed Switch On)	3-5
Backspace Mechanism	2-5	Register Key	3-5
Card Feed Mechanical Action	2-7	Backspace Key	3-6
Card Hopper and Feed Knives	2-8	Duplication	3-6
Card Registration Mechanics	2-11	Dummy Punch Clutch Cycle	3-6
Pressure Roll Linkage and Card Registration	2-11	Manual Duplication (One-Column, Program Control Off)	3-6
Registration Stop Plate	2-13	Manual Duplication Sequence Chart	3-8
Stacker Assembly	2-14	Mechanical Relationship – Punch Index and Escapement	3-8
Card Lever Contacts	2-15	Manual Duplication (More Than One Column)	3-9
Card Feed and Punch Circuit Breakers	2-15	Manual Duplication (Program Control On)	3-11
Keyboard Mechanics	2-15	Automatic Duplication	3-11
Bail and Latch Contacts	2-18	Skipping	3-13
Keyboard Restoring Components	2-18	Manual Skip – Program Control Off	3-13
Keyboard Interlocks	2-20	Manual Skip – Program Control On	3-15
Special Character Codes (Combination Keyboard)	2-20	Automatic Skipping	3-15
Punch Drive Mechanics	2-21	Multipunch (Multiple Punching)	3-15
Punch Drive Unit	2-22	Release Key, Not Programmed, with Cards	3-17
Punch Operating Arm	2-24	Release Key, without Cards	3-18
Interposer Bail Contacts (Two Used)	2-26	Release – Program Control On, with Cards	3-18
Space Interposer	2-26	Release Key – Blank Field	3-18
Energizing Interposer Magnets	2-26	Release Key – Manual Field	3-18
Punch, Die, and Stripper	2-27	Release Key – Auto Skip Field	3-19
Program Sensing Mechanism	2-28	Release Key – Auto Dup Field	3-19
Program Shaft	2-28	Clear	3-20
Program Control Lever (Handle), Release Bail, and Drum Interlock	2-28	Printing Control	3-20
Starwheels and Starwheel Sensing	2-29	Left-Zero Print	3-21
Starwheel Sensing Contacts	2-29	WIRE CONTACT RELAY MACHINES	3-23
Program Handle Switches 1 and 2	2-29	Manual Punching Operation	3-23
Program Cam Contacts	2-30	Program Levels (Program 1 and Program 2)	3-23
Pin Sensing Unit Mechanics	2-30	Error Reset	3-25
Pin Bail and Pin Bail Arm	2-31	Feed Key	3-25
Master Card Lever	2-31	Feed Key – First Depression	3-26
Sensing Pin Separator	2-32	Feed Key – Second Depression	3-26
Sensing Pins and Contacts	2-32	Card-to-Card Skip (Auto Feed Switch On)	3-27
Reed Relay	2-33		
Reed Relay Terminology	2-33		
Reed Relay Package	2-34		
Reed Relay Identification	2-34		

Register Key	3-27	Read Out, Punch Out	4-16
Backspace Key	3-28	Left-Zero Credit Field	4-19
Duplication	3-28	Credit Read In	4-19
Dummy Punch Clutch Cycle	3-28	Credit Read Out, Punch Out	4-19
Manual Duplication (One Column, Program Control Off)	3-28	Left-Zero Logic Controls	4-22
Manual Duplication Sequence Chart	3-30	Chapter 5. Power Supplies and Control	5-1
Mechanical Relationship – Punch Index and Escapement	3-30	Card Punch Voltages	5-1
Manual Duplication (More Than One Column)	3-31	Power On	5-2
Manual Duplication (Program Control On)	3-33	Chapter 6. Console and Maintenance Features	6-1
Automatic Duplication	3-33	Keys, Switches, and Indicators	6-1
Skipping	3-35	Toggle Switches on Switch Panel	6-1
Manual Skip – Program Control Off	3-35	Functional Keyboard Keys	6-2
Manual Skip – Program Control On	3-37	Character Keys	6-3
Automatic Skipping	3-37	Interlock Circuits	6-3
Multipunch (Multiple Punching)	3-37	Operating Instructions	6-4
Release Key, Not Programmed, with Cards	3-38	Functional Operations	6-4
Release Key, without Cards	3-39	Sequence of Operations	6-4
Release – Program Control On, with Cards	3-40	Manually Inserting and Registering Cards	6-5
Release Key – Blank Field	3-40	Numeric and Alphabetic Information	6-5
Release Key – Manual Field	3-40	Program Card Preparation	6-6
Release Key – Auto Skip Field	3-41	Manual Numeric Field	6-7
Release Key – Auto Dup Field	3-41	Manual Alphabetic Field	6-7
Clear	3-42	Manual Skip (Program Controlled)	6-7
Printing Control	3-44	Automatic Skip	6-7
Left-Zero Print	3-44	Automatic Duplication (Numeric Information)	6-7
Chapter 4. Features	4-1	Automatic Duplication (Alphabetic Information)	6-7
Left-Zero Insertion Feature	4-1	Manual Duplication (Program Control On)	6-8
Left-Zero Program Card	4-1	Chapter 7. Wiring Diagrams	7-1
Left-Zero Error Reset Key	4-1	Reed Relay Machines	7-3
Left-Zero Relays	4-1	Wire Contact (W/C) Relay Machines	7-23
PRINCIPLES OF OPERATION FOR REED RELAY MACHINES	4-1	LZ Capacitor A Registers	7-35
Read In	4-1	Appendix A. Machine Characteristics	A-1
Read Out, Punch Out	4-5	Appendix B. Electrical Symbols and Identification	
Left-Zero Credit Field	4-8	Base Machine	B-1
Credit Read In	4-8	Keyboard Electrical Functions	B-2
Credit Read Out, Punch Out	4-8	Index	X-1
Left-Zero Logic Controls	4-10		
PRINCIPLES OF OPERATION FOR WIRE CONTACT RELAY MACHINES	4-10		
Read In	4-10		

Chapter 1. Introduction

- The IBM 29 Card Punch transcribes original data to data cards in the form of punched holes.
- A printing mechanism enables printing a character in the same column as its respective punched holes.
- Codes required for IBM System/360 can be punched and printed.
- Two separate program levels allow multiple changes between program levels within a card or at the start of a card.
- A clear key causes multiple register and release cycles without feeding until the card transport is clear of all cards.
- Printed circuit techniques, reed relays, and wire contact relays are used.
- Major units are pluggable as an aid for feature installation and serviceability.

Data cards have been called the operating unit of IBM machines. All information pertaining to a particular transaction is placed in this card in the form of punched holes. The card contains 12 horizontal rows and 80 vertical columns for punching. The cards are 7 $\frac{3}{8}$ " wide, 3 $\frac{1}{4}$ " high, and 0.0065" thick.

Figure 1-1 shows how the 12 positions are punched singly to represent a numeral, or in combination to

represent a letter or a special character. The 11 punching position is also used to identify special cards and negative numbers.

At the option of the operator, the IBM 29 Card Punch with printing mechanism can print characters at the same time they are punched. Each character prints above the column punched (Figure 1-1).

Figure 1-2 is a front view of the machine (covers off). Figure 1-3 is a rear view of the reed relay machine (covers off). See Chapter 4, "Left-Zero Relays," for the wire contact relay machine.

Card Movement

- Cards are moved:
 1. From hopper.
 2. To detail station.
 3. To punch station and registered.
 4. Through master station.
 5. To read station and registered.
 6. Through eject station.
 7. To stacker and held by a card weight.

Before information can be punched, read, or printed, the card must be moved to the punching or reading

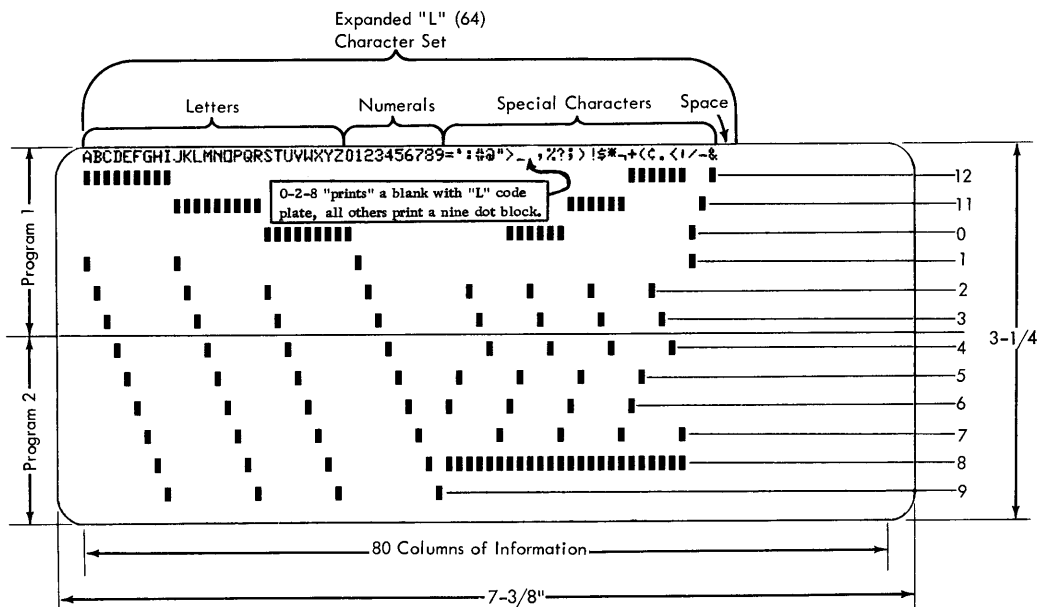

Figure 1-1. Punched Card With Printing

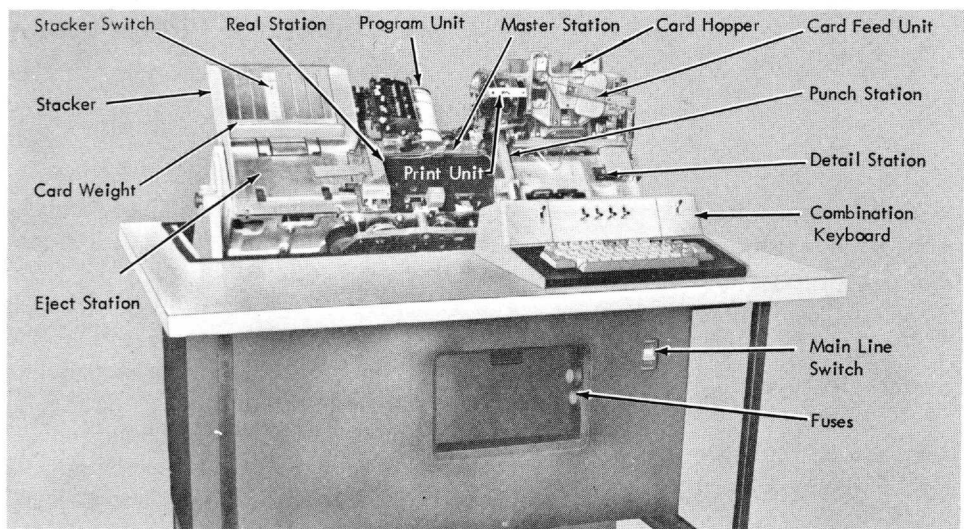

Figure 1-2. IBM 29, Front View (Covers Off)

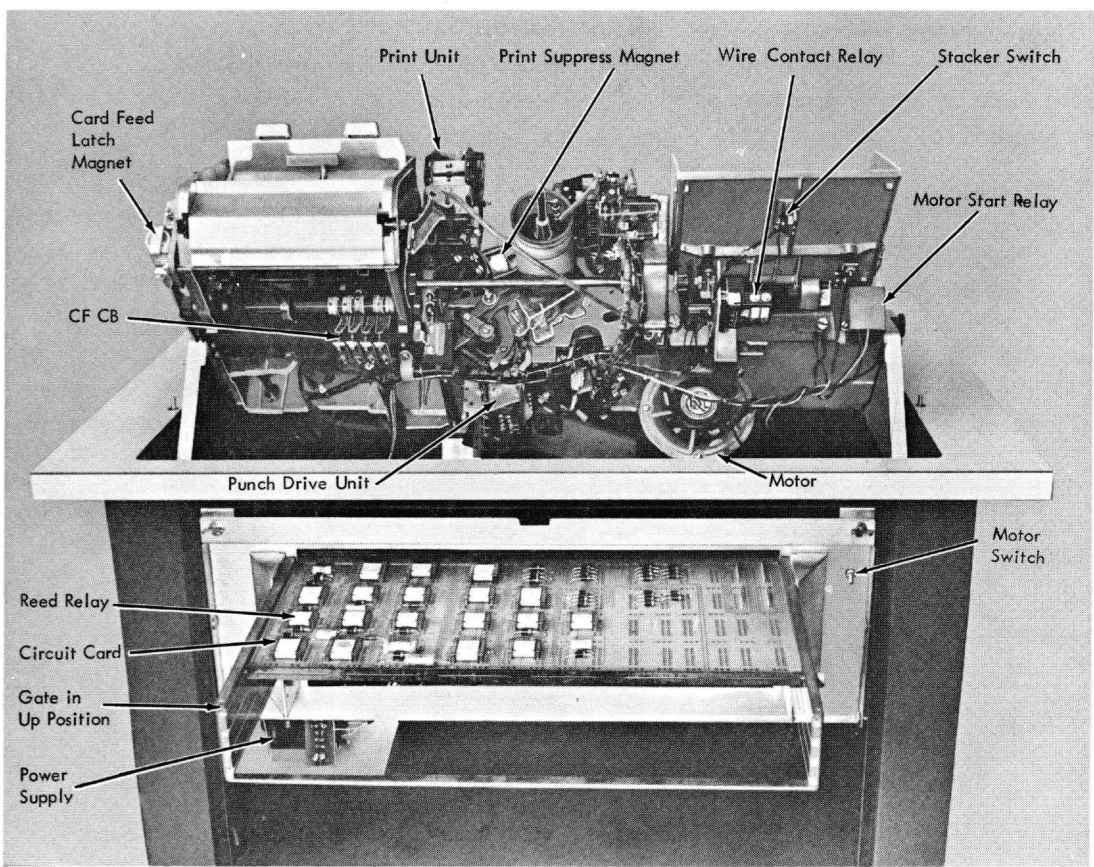

Figure 1-3. IBM 29, Rear View (Covers Off), Reed Relay Machine

stations of the machine. In addition, the card feed unit must also perform the following: contain a supply of cards for the machine, draw one card at a time from that supply, and stack the cards in temporary storage after they have passed the punching and reading stations.

The hopper contains the supply of cards for feeding into the machine. The cards are placed in the hopper 9-edge down, column 1 to the left. Each card feeds from the front of the hopper down into the machine with column 1 entering the punch station first (Figure 1-4). The card moves from the hopper through the punch station; then through the reading station to the stacker. The card stacker, the punch station, and the master station are provided with interlocks to stop the machine under faulty conditions.

Under normal operating conditions, one card is in the punch station and one card is in the detail station at all times (the first card is being registered or being punched, and the second card is in a preregistered condition). By registering the second card shortly after the first card is punched in column 80, three-fourths of the feeding time is saved over the time that would be required for two separate feed cycles.

On the first card feed cycle, a card leaves the hopper, passes through stage 1 and ends at stage 2 (detail

station). On the earliest portion of the second card feed cycle, a card is aligned at position 3 and pushed to 4 preparatory to punching (punch station).

Punching and Reading Sequence

- The IBM 29 punches and reads cards column by column (serially).
- The card passes through the machine 12-edge up and column 1 first.
- There are 12 punches at the punch station and 12 pairs of sensing pins at the card read station.

Punch Registration: When a card is in position for punching or reading, it is said to be registered. For each hole punched in a card, there is a predetermined horizontal and vertical distance from the edge of the card to the edge of the hole. An IBM card gage is used to determine if a card is punched on or off registration. A card punched with holes too far to the left or right, is off horizontal registration; too high or too low, off vertical registration.

Card Registering: Figure 1-4 shows the program drum and master card registered in column 1 while

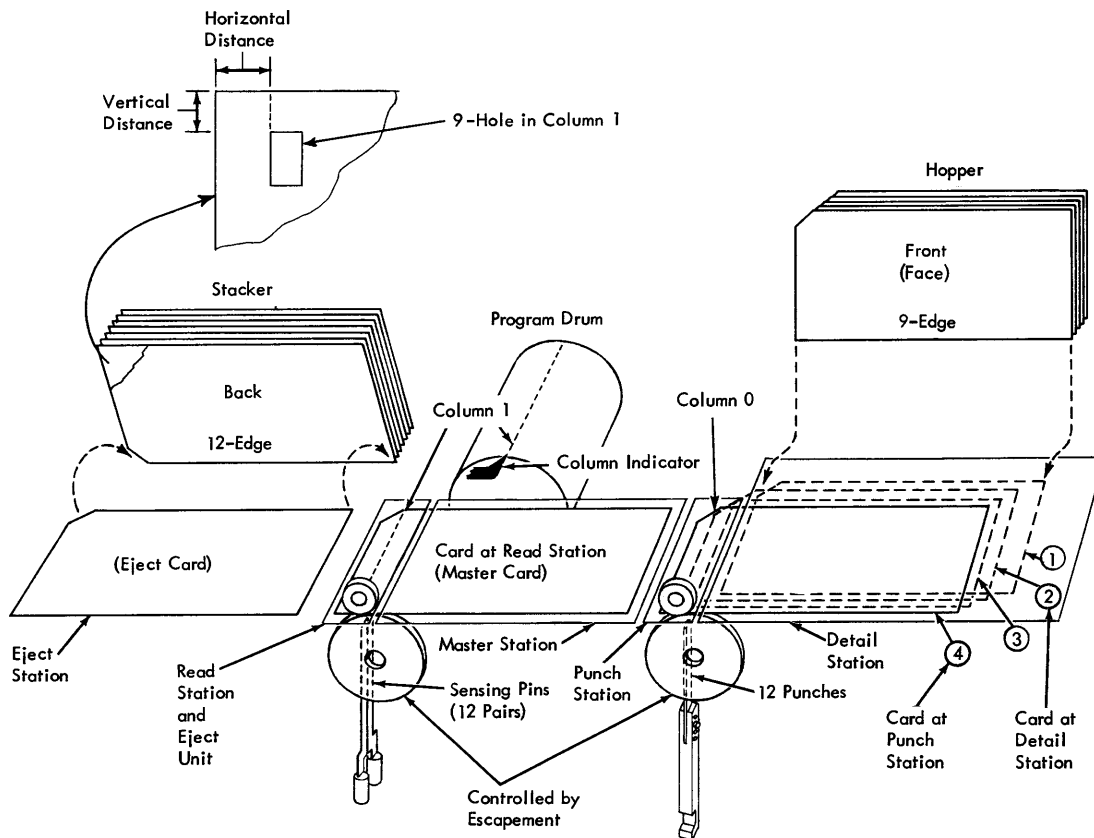

Figure 1-4. Card Path Through Machine

the detail card is registered at column 0. Do not use lower-left corner-cut cards. (If used, the feed rolls in the IBM 29 Card Punch will be unable to grip the card, especially in the punching station, where the card is registered in column 0).

Card Printing

- **The IBM 29 can print information across the top of the card; one character above each of the 80 card columns.**
- **Printing and punching occur in the same cycle.**
- **Printing is turned on or off by a print switch located on the keyboard switch panel.**

Card Hopper

- **Stores cards before processing.**
- **Holds about 500 cards.**
- **Cards are placed in the hopper face-forward with 9-edge down.**

Card Feed, Detail Station, and Punch Station

- **A card feeds from the hopper to the detail station each time the feed key is pressed.**
- **To punch the first card, press the feed key twice, or press once and hold down until the card is registered.**
- **A card must be registered in the punch station to make the keyboard active.**
- **The card is registered when the left end (column-1 end) of the card is in the correct position for punching.**

The first depression of the feed key moves a card from the hopper to the detail station. The second depression registers the first card in the punch station for punching and feeds another card from the hopper to the detail station.

When you look at the card in the punch station, the column-1 end of the card is on the left and the column-80 end is on the right.

Master Station and Read Station

- **Under control of the escapement mechanism, the master station accepts the card that has just been punched.**
- **The read station is used when reading a punched card that has data to be transferred to the new card at the punch station.**
- **The card at the read station is the master card.**
- **The card at the punch station is the detail card.**
- **Duplication can be manual or program controlled.**

A typical operation punches some fields with new information and duplicates other fields that remain the same for the whole group of cards. As each card is completed, it passes to the read station and becomes the new master card. The card just registered at the punch station becomes the new detail card. Cards are registered at both stations by pressing the register key.

Pressing the duplication key causes the cards at both stations to move column by column. The card at the read station is sensed or read, and its holes are duplicated or punched into the card at the punch station.

The read station is located approximately one card length to the left of the punch station. Consequently, each card that has been punched passes through the read station as the next card is being punched. The card in the punch station lags one column behind the card in the read station. The two cards move in synchronization, column by column. The program drum position advances column by column in synchronism with the card being read. Reading from one card to the next can be controlled by programming, field by field, so that only the desired information is transferred from the first card to the second.

Eject Station

- **Under control of the escape mechanism, the eject station accepts the card that has just been read.**
- **The eject station is located to the left of the read station and below the stacker.**
- **A card fed from the read station, with the auto feed switch off, stops in the eject station.**

Stacker

- **The stacker is under control of the card feed clutch.**
- **The stacker stores the cards after processing.**
- **The stacker holds approximately 500 cards.**

A card fed from the read station moves through the eject station directly to the card stacker (with the auto feed switch on). As the stacker fills up, the cards move a card weight up against the stacker switch. The stacker switch opens the circuit to the card feed clutch and card feeding stops.

Program Unit

- **The program unit controls the automatic functions of the machine column by column.**
- **The program control lever (handle) raises and lowers the starwheels.**

- **The program control lever operates the program-control-lever switch and interlocks the program drum.**

The program unit contains a sensing mechanism (starwheels) that mechanically senses holes in the program card. The program card is mounted on a program drum within the unit. For correct operation, the program drum must be placed so that the aligning pin at the bottom of the drum fits into the hole in the column indicator wheel. The column indicator (Figure 1-5) points out the next column to be encountered as cards pass the punch or read station.

Turning the program control lever to the right raises the starwheels and turns program control off; turning the lever to the left lowers the starwheels and turns program control on. When using the program unit to perform automatic operations, program control must be on.

The starwheels must be raised to remove or install the program drum and program card.

A card containing certain prepunched codes (Figure 1-6) is mounted on the program drum (Figure 1-7) and inserted in the machine. The starwheels mechanically sense the holes in the program card. The me-

chanical motion is converted into electrical impulses to control certain automatic functions, and shifting between alphabetic and numeric punching. Each operation is designated by a specific code punched in the program card. The program drum turns in step with the movement of the cards as they pass through the punching and reading stations, so that the program codes, which are read by the starwheels, control the operation of the machine column by column.

The program unit is activated by lowering the starwheels. The auto dup/auto skip switch must be on for program control of these operations. Two program level modes are provided and controlled by a switch (located on the keyboard switch panel) and two keys (located on the keyboard).

Under program control, the IBM 29 Card Punch duplicates at the rate of 20 columns per second. Manual duplication is about 10 columns per second. Skipping and card release proceed at the rate of 80 columns per second. The next card feeds into position in $\frac{1}{4}$ second.

The IBM 29 Card Punch *with printing mechanism* automatically duplicates at a slightly slower speed (18 columns per second) because of restrictions of the printing mechanism; manual duplication is 9 columns per second.

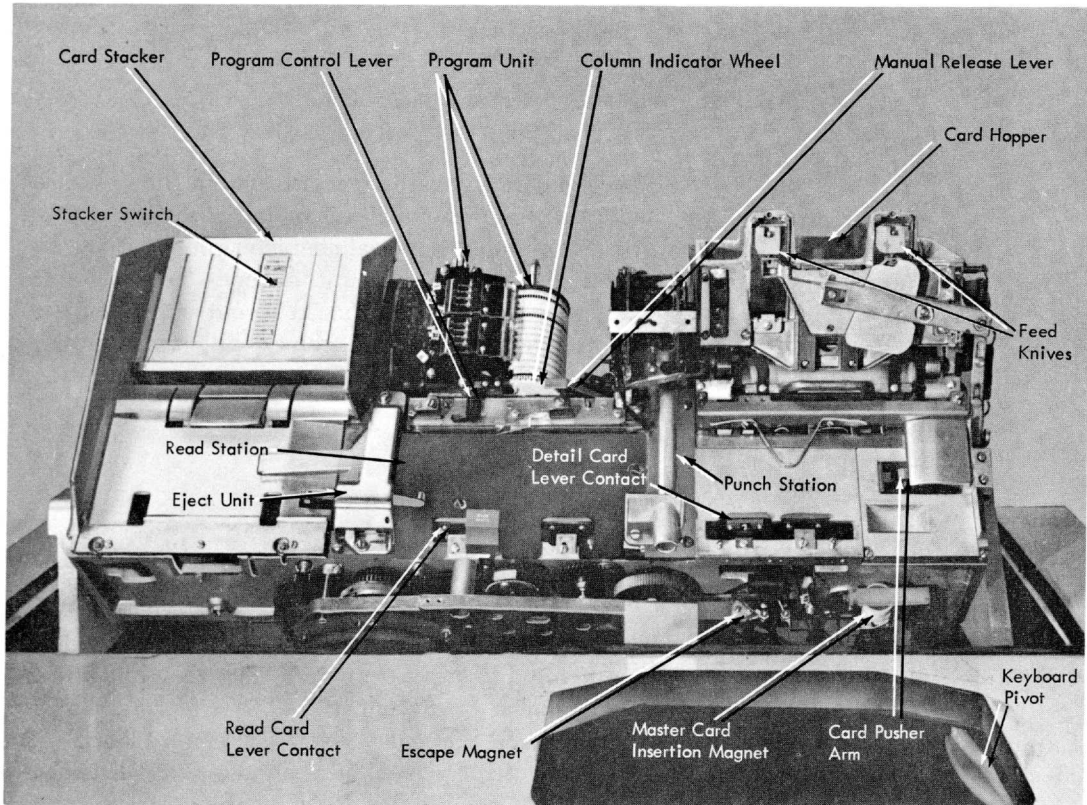

Figure 1-5. Card Transport Area

FUNCTION	PROGRAM ONE		PROGRAM TWO	
	First Column	Rest of Field	First Column	Rest of Field
Key Numerics - Field Definition	Space	12	Space	4
Key Alphabetic	1	12-1	7	4-7
Auto Skip	11	12	5	4
Duplicate Numeric	0	12	6	4
Duplicate Alphabetic	0-1	12-1	6-7	4-7

Figure 1-6. Program Card Codes

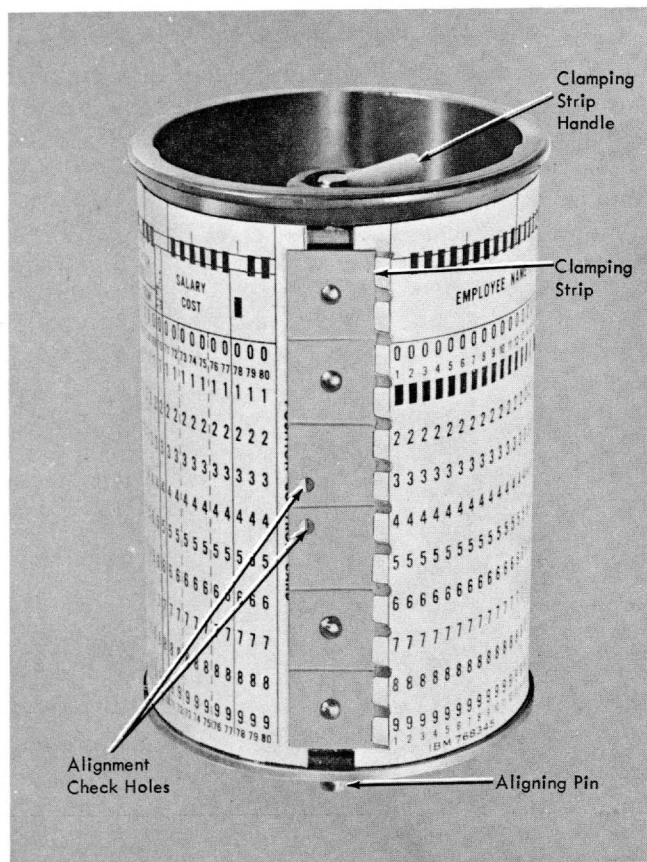

Figure 1-7. Program Drum

Keyboards

- The numeric keyboard (Figure 1-8) can punch the digits 0-9, and two special characters (& and -).
- The combination (Expanded) keyboard (Figure 1-9) can punch 63 different codes including letters, numerals, and special characters, 62 of which can be printed.

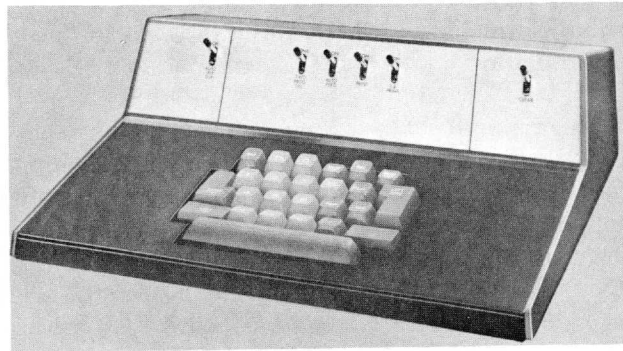

Figure 1-8. Numeric Keyboard

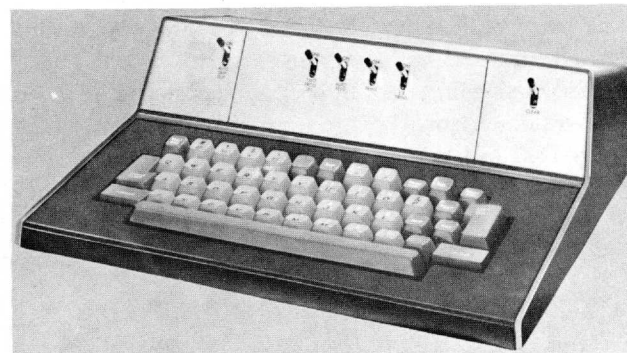

Figure 1-9. Combination Keyboard

The keyboard, which is recessed within the desk area and can rotate about 20°, can be either numeric or alphabetic-numeric-special character combination. The combination keyboard punches one “non-printable” code: the 0-8-2. The keyboard layout corresponds to that used in the latest machines with operator keyboards.

Machine Wiring Diagram

- Instructional wiring diagrams are in Chapter 7.
- All logic flow is from left to right.

The wiring diagram is drawn in logic flow form rather than being drawn point to point. The voltage distribution is shown on Systems 01.29.18.0 (for reed relay machines) or Sections 19 and 20, P/N 5405952 (for wire contact relay machines). Circuit details are included in “Appendix B.” Refer to the wiring diagram location chart for component locations (Systems

01.29.18.0 for reed relay machines or Sections 19 and 20, P/N 5405952, for wire contact relay machines).

Because the Model B machine incorporates the same circuits as the Model A, and in addition, left-zero circuitry, only Model B wiring diagrams are contained in this manual; one set for reed relay machines, and one set for wire contact relay machines.

The wiring diagram is printed in loose-leaf form and can be kept in a binder. Each page has an engineering change (EC) number. New pages can be added as changes or new features are released.

Location Chart

- **Systems 01.29.17.0 and 01.29.18.0 are the location charts for reed relay machines; sections 19 and 20, P/N 5405952 is the location chart for wire contact relay machines.**
- **Keyboard component locations are shown on separate pages.**

Point-to-point power distribution in the machine is shown on the wiring diagram location chart. Plus 48-volt source power comes from TB2-5, and 0 volts comes from TB2-4. Plus 48 volts is distributed to some machine circuits through the card lever relay points.

Each relay's name and number and its coil and point location is given on the wiring diagram location chart.

The punch TB (terminal block) is described.

Rectifiers are listed as to part number or type, identification number on the wiring diagram, and the section of the wiring diagram where located.

The connector chart gives the pin number of each wire, the reed card tab identification (letter), and the location of each pin in the wiring diagram. *Example:* E26, pin 26 on tab E, is in section 8B.

Reed relay data, giving the reed relay part number, the coil resistance, and identifying the points as N/O (normally open) or N/C (normally closed) is shown in the reed relay data chart.

The CF (card feed) cams, their location in the wiring diagram, their part numbers, and the make and break times are given in the CF cam chart.

The P (punch) cam chart gives the same kind of data as the CF cam chart.

Sections 3 and 4 show the latch contacts, bail contacts, and edge connectors of the keys on the 64-character keyboard. Systems 00.29.10.0 shows a chart listing the keystem positions, the graphics, card code, and the bail contacts associated with the 64-character keyboard. Sections 1 and 2 show the latch contacts and connectors associated with the numeric keyboard. The keyboards are connected to the machine through the C and Z edge connectors.

Card Feed and Punch: Mechanical Timing Charts

- **These charts are on Systems 00.29.10.0.**
- **They compare the timings of related motions of components within the units.**

Cycles and Timings

- **Machine punch timing is in terms of individual columns, each of which is broken down into degrees.**
- **360° represents the total time for a single column cycle of escaping and punching.**

One machine cycle, 360°, is equal to one punch clutch index cycle, or one card column. A signal to punch or read causes the card to escape (move to the next column) and then be punched or read. The punch clutch latches at 345° of a machine cycle.

Punch Drive Shaft: Revolves at 1,200rpm, or 20 cycles per second, with 1° equal to 0.139ms.

On the IBM 29 with the printing mechanism, the shaft revolves at 1,080rpm, or 18 cycles per second, with 1° equal to 0.154ms.

It is necessary to consider the relationship between degrees and milliseconds to determine the time required for a mechanical operation of the various units of the IBM 29. In the following summary, comparisons relate to the punch shaft speed of 20 cycles per second. Mechanical timings are nominal. The pick time and drop time of reed relays are negligible.

NOTE: The responses of the clutch interposer and escape magnet armatures vary according to the voltage levels and temperature levels.

Punch Clutch Cycle: Equals about 50ms. 1ms is equal to 7.2°, and 360° equal one cycle. 1° equals 0.139ms. The punch shaft runs at 1,200rpm.

CF (Card Feed) Clutch: Picks up at column 82½ during auto feed. The card feed shaft runs at 60rpm. 1° equals 2.78ms. 1ms equals 0.36° of the CF index.

CF Shaft: Starts to turn 28ms after PCC1 (program cam contact 1) makes.

Card Escapement: Starts at 223.2° of the punch clutch cycle.

CF Latch Magnet: Must be sealed at 13° of the CF (card feed) cycle to prevent feeding.

Read Card Lever Contact (Master Station): Makes at approximately column 60 of the first card.

Detail Card Lever Contact: Makes at approximately 5° to 10° of the CF cycle when a card is registered at the punch station.

Interposer Bail Contacts: Open at approximately 70°.

Starwheel Contacts: Make at 252°, during auto dup cycle.

Auto Dup Speed: 20 columns per second (50ms per column).

Manual Dup Speed: 10 columns per second (100ms per column).

Card-to-Card Skip Speed: 12ms per column.

PCC1 (Program Cam Contact 1): Breaks at 24.5° on a CF cycle. The contact is made for eight columns (or 96ms).

PCC2 (Program Cam Contact 2): Returns to normal at 22.3° on a CF cycle. The contact is made for approximately 6 columns (or 72ms).

Automatic Duplication in First Column of Card: The dummy punch cycle starts at 77° of the CF cycle. Energization of interposer magnets starts at 81° of the CF cycle.

Escape Magnet Armature: Needs about 8ms for magnet armature attraction, closing the armature contact, and allowing card movement to begin.

Card Escapement: Takes about 12ms for one column, the time varying with machine friction torque.

Punch Clutch Armature: Needs about 8ms to be attracted.

Punch Clutch: Needs about 15ms for spring take-up, the time varying with machine age and clutch lubrication.

The following chart lists the specifications of various magnets mentioned in this section.

NAME	COIL RESIST- ANCE (ohms)	RATED CURRENT (ma)	PICK-UP TIME (SEAL) (ms)
Escape Magnet	171	280	8
Punch Clutch Magnet	171	280	8
Interposer Magnet	171	280	8-10
CF Clutch Magnet	171	280	8-10
Keyboard Restore Magnet	190	250	8-10

Continuously Running Mechanism

- The three main mechanical areas of the IBM 29 Card Punch are:
 1. Card Feed Mechanism (feeds, registers, and stacks the cards).
 2. Escapement Mechanism (moves the cards column by column through the punch mechanism).
 3. Punch Mechanism (punches the card).

Drive Mechanism

- Powers the three main mechanical areas of the IBM 29.

A $\frac{1}{2}$ horsepower motor, with a high-low relay for an external starting switch, powers the machine.

Figure 2-1 is a block representation of the three main mechanical areas. Figure 2-2 shows that the three areas are controlled by clutches. The initial drive is from the drive motor through two belts. One belt drives a reduction drive mechanism and the other belt drives the punch clutch (Figure 2-3).

The prime use of the reduction drive assemblies is to reduce the speed to the card feed and escapement mechanisms.

The punch drive unit is operated at 1,200rpm through the motor drive belt. If the IBM 29 has the print mechanism, the drive belt turns the drive unit at 1,080rpm. Motor speed (to drive unit speed) is reduced by V-pulleys. The 1,225rpm motor speed is reduced to 1,200rpm drive unit speed, or 1,080rpm on machines with a print mechanism.

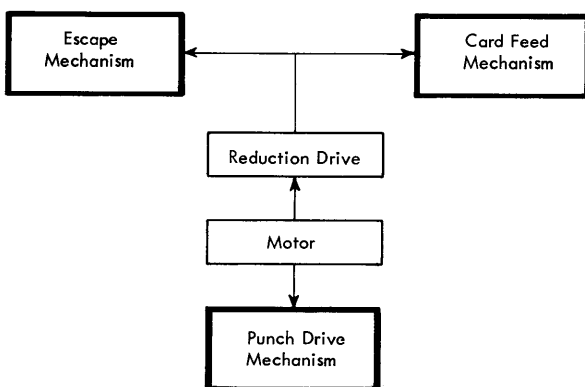

Figure 2-1. Three Main Mechanical Areas

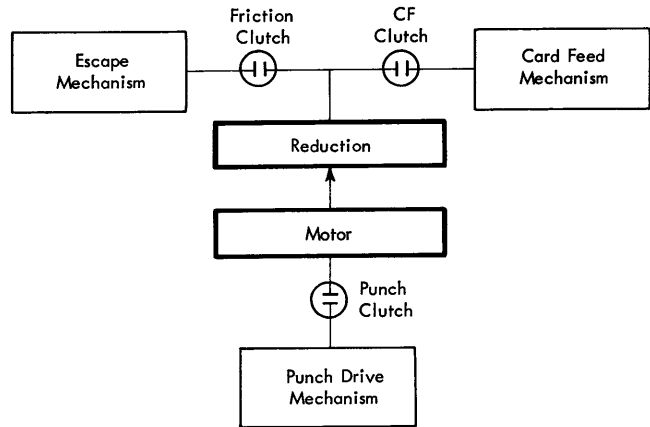

Figure 2-2. Clutch Function

Figure 2-3 shows a double V-pulley and two belts. Both the punch clutch belt and the motor belt are driven directly by the motor shaft double V-pulley. The punch clutch belt on this open gear reduction drive is adjusted by moving the motor mounting bracket. Tightening the punch clutch belt does not vary the clutch speed.

An idler arm and its spring (Figure 2-3) is used for motor belt tension. The spring-controlled motor-belt tension, through the idler arm and roller, keeps a constant drive torque on the drive shaft.

The eject idler gear is pinned to one end of the drive shaft, and a steel drive gear is pinned to the other end. The eject roll idler gear is continuously turning on the drive shaft which is parallel to the driven shaft (Figure 2-3). On the straight-cut gear arrangement, the steel drive gear is meshed with the large fiber gear.

The transverse drive shaft drives the card feed clutch ratchet assembly.

The eject feed roll and register feed roll turn whenever the motor is running via the use of idler gears.

The continuously running member of the friction clutch assembly is the friction clutch drum. The reduction drive reduces the motor speed to card feed and escapement speed; punch drive speed is reduced by belts and pulleys; card feed and escapement speed is reduced by gears.

When the main line switch is turned on, the motor in the IBM 29 Card Punch and all mechanisms not under control of a clutch run continuously. The motor,

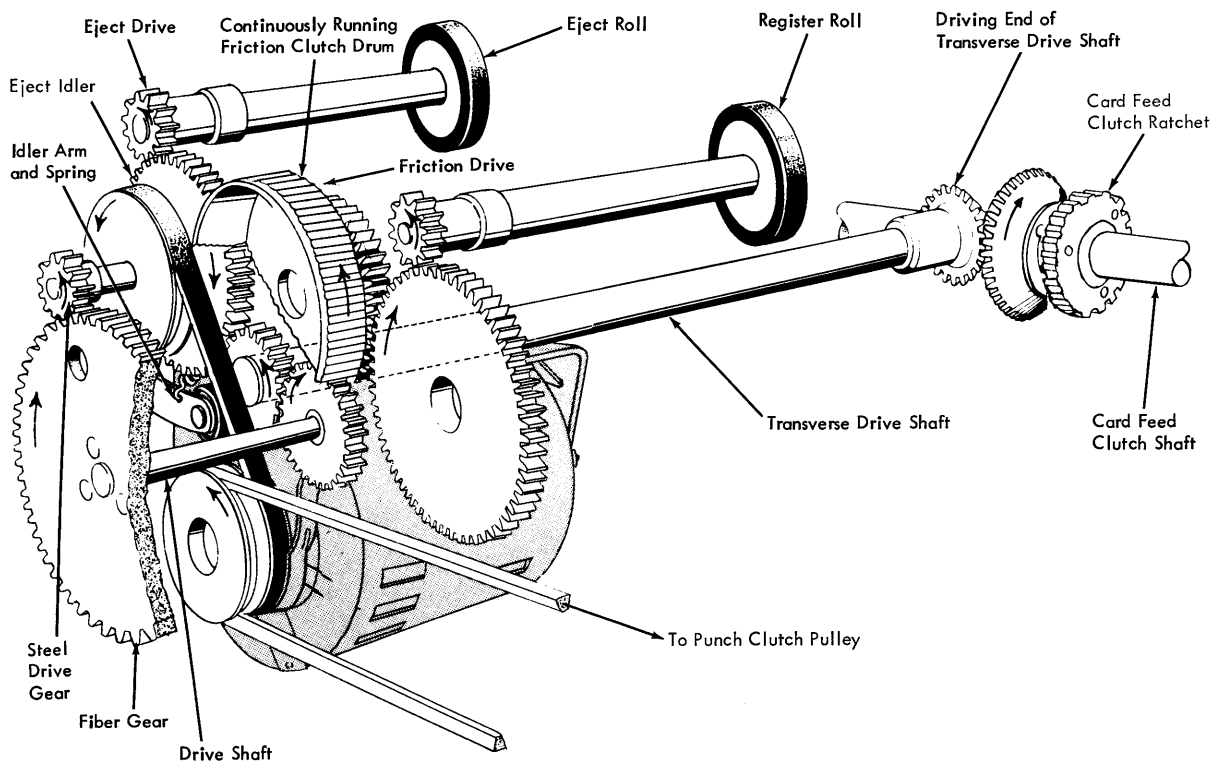

Figure 2-3. Reduction Drive

belts, reduction drive mechanism, and the gear train, including the three clutch driving members, make up the continuously running mechanism.

Friction Clutch and Escapement Mechanism

- **The clutch and escapement advance the cards through the master and detail station column by column.**
- **The friction clutch maintains a constant torque at the escape wheel.**

When the escapement armature is pulled away from the wheel, the escapement gear train turns smoothly and rapidly. The friction clutch drum is continuously running, and pressure is applied to it by the clutch spring via the nylon clutch ring. (This maintains a constant torque at the escape wheel and the escape armature.) The gear train must be free of binds, and must mesh in complete alignment to prevent any delay in escapement.

The friction clutch provides a constant torque to the escape wheel and drives the program drum and the gear train, which controls column-by-column card movement (or escapement).

The continuously running friction drum is driven through gear reduction and turns freely on the drive

shaft. Friction between the drum and the nylon ring turns the friction drive shaft. The hub containing the friction ring and its supporting spring is pinned to the friction drive shaft. Torque to the hub is produced by friction between the drum and the nylon ring. To produce constant torque on the friction drive shaft, a silicon lubricant is used on the surfaces of the nylon ring and the drum. The torque applied to the friction clutch hub varies directly with the adjustable spring tension that holds the nylon ring against the drum.

The escape wheel and the escapement magnet assembly control the movement of the escapement gear train. The cards at the read and punch stations are moved by the feed wheels. One feed wheel is pinned to the friction drive shaft, and the other feed wheel is pinned to the escape wheel shaft. In the escapement gear train (Figure 2-4), note the direction of rotation of the friction drum, the program drum, and the escape wheel. The gears between the friction drive shaft and the escape wheel shaft are another example of the use of idler gears. The program drum (part of the escapement) is under control of the escapement magnet assembly and is driven through the friction clutch. Moving one tooth on the escape wheel, with respect to the escape armature, moves the entire escapement one card column.

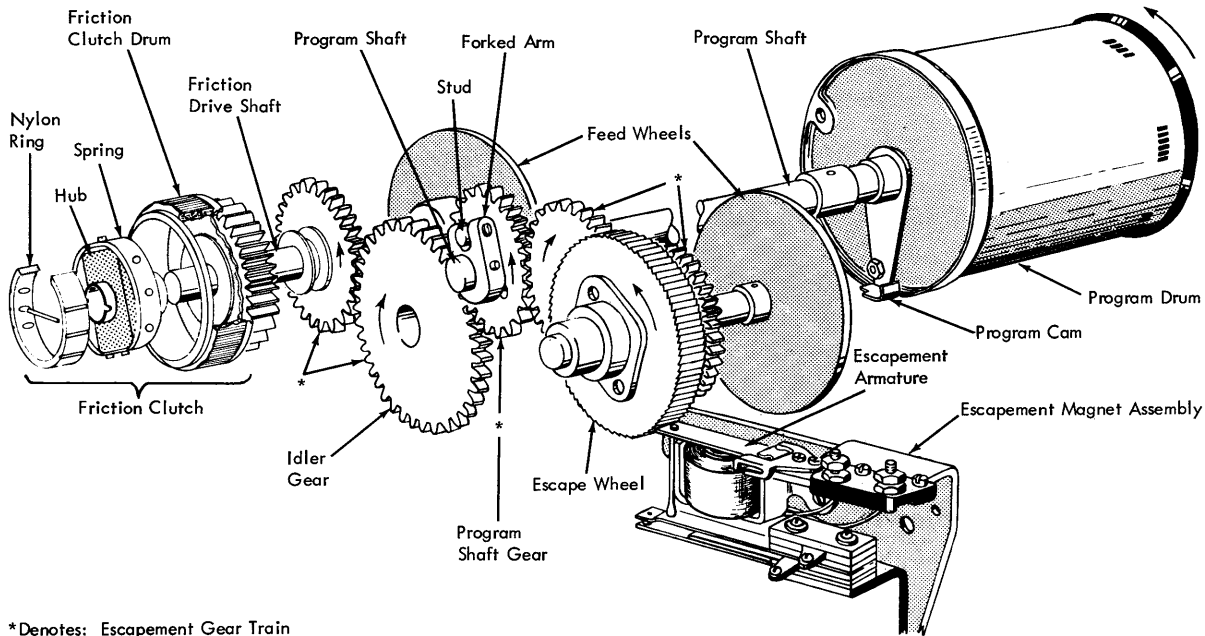

*Denotes: Escapement Gear Train

Figure 2-4. Friction Drive to Escapement

Magnet and Clutch Assemblies

- The magnet assemblies are electrically impulsed to control mechanical action.
- The clutch assemblies transfer, stop, or start mechanical action by coupling or uncoupling one to the other.

Although the operator manually controls the keys, the card punch uses a number of magnet assemblies for controlling mechanical units.

All magnet assemblies have a coil wound on the soft iron core that is mounted to the yoke. The magnet assembly armature is the part that moves when the coil is energized and the armature spring returns the armature to its normal position.

All magnet assemblies used in the IBM 29 Card Punch have four parts in common: coil, yoke, armature, and an armature return (a spring, in most cases).

The parts in common on the various magnet assemblies do not necessarily have the same physical properties. The wire wound coil is mounted to the yoke by its iron core and, when current passes through the windings of the coil, it becomes an electromagnet. The U-shaped yoke has the core of the coil mounted in the center (Figure 2-5). When the magnet coil is energized, the armature is attracted toward the core and spans the tips of the yoke. After de-energizing the magnet, a spring restores the armature to its home position. The operating strap in the escapement magnet assembly functions as an armature return spring.

Figure 2-5 shows a typical use of a magnet assembly.

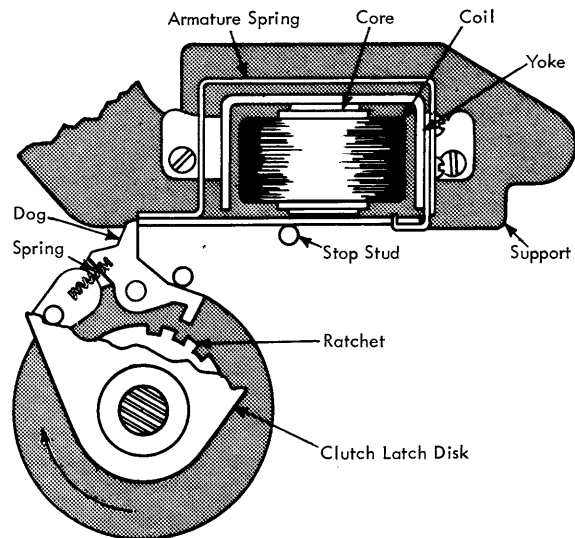

Figure 2-5. Card Feed Magnet and Clutch Assembly

The card feed clutch remains latched as long as the dog is latched on the armature. The card feed ratchet runs continuously. Attracting the armature allows the dog to pivot and engage in the ratchet.

The stop stud is fixed and the yoke is adjusted relative to the stop stud. Armature-to-dog latching and unlatching clearance is determined by the position of the yoke with respect to the stop stud. With the dog engaged in the ratchet and the magnet assembly de-energized, the armature spring holds the armature against the stop stud. The card feed clutch latches

when the tail of the dog strikes the tip of the armature; this disengages the clutch.

The card feed clutch dog pivots on a stud attached to the clutch latch disk. A feed clutch cycle is the rotation of the clutch latch disk from the point where the dog unlatches from the armature to where it re-latches on the armature. When the dog is engaged, the clutch disk rotates with the ratchet.

The dog spring shown in Figure 2-5 pivots the unlatched dog; however, when the dog is latched, the spring tends to pivot the clutch latch disk in reverse. When the dog is latched, the clutch latch disk is detented; this prevents it from turning in reverse.

Card Feed Clutch

- **The card feed clutch is a dog and multitoothed ratchet type of clutch, which turns the card feed drive.**

The card feed ratchet turns continuously, but the clutch latch disk turns only during a card feed cycle. The clutch latch disk is pinned to the horizontal card feed shaft shown in Figure 2-6. The card feed ratchet is also on the horizontal card feed shaft.

The mechanical loading of the card feed shaft acts as the detent to the card feed clutch latch disk when the dog is latched by the armature. Unlatching the dog allows the multitoothed ratchet to catch and carry

the latch disk and the card feed shaft through the card feed cycle.

Escapement Magnet Assembly

- **Allows the escape wheel to rotate via force from the friction drive.**
- **Controls movement of the cards at the punch and read stations and movement of the program drum.**
- **Restored by spring tension of the escape contact operating strap.**

The escape contact operating strap is the escape magnet armature return spring (Figure 2-7) and is transferred by an operating pin. When the escape magnet is de-energized, the escape contact operating strap opens the contacts and, with the connected operating pin, restores the escape armature. The operating pin is inserted between the escape armature and the escape contact operating strap.

The escape armature controls the movement of the escape wheel. The tip of the armature, when restored, is in a tooth of the escape wheel and prevents movement of the escape mechanism. The escape armature is retained on its pivot by a bracket, a spring, and the force of the escape wheel against its tip. When back-spacing, the escape armature is held to its pivot only by the bracket and spring.

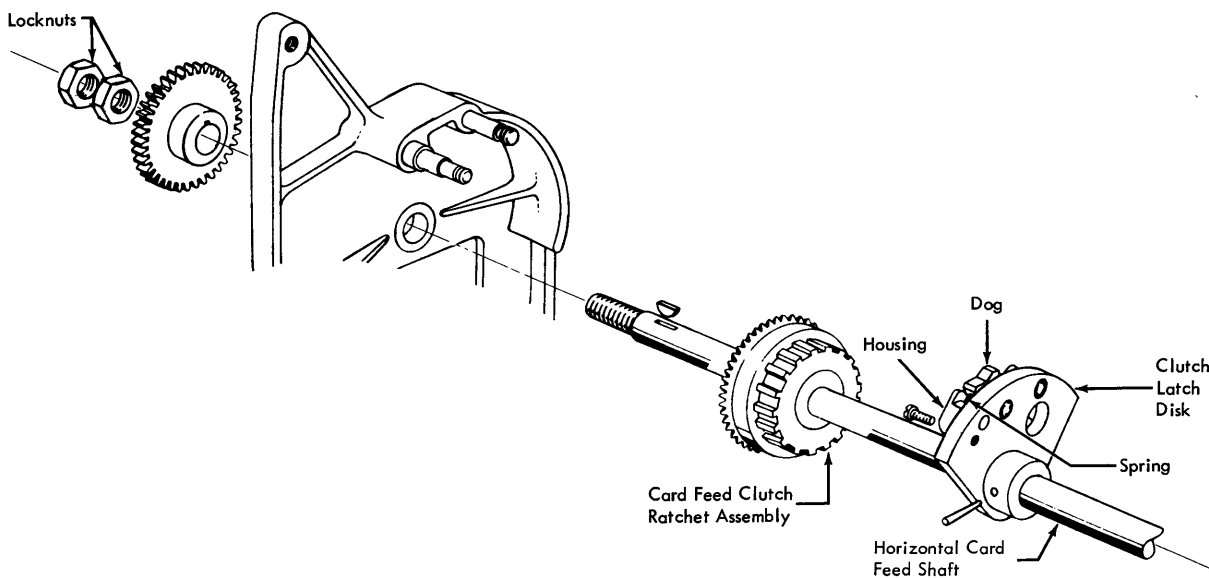

Figure 2-6. Horizontal Card Feed Shaft

The escape magnet assembly is positioned by a pivot pin. Escape armature to escape wheel adjustment is obtained by moving the escape magnet assembly on this pivot pin (Figure 2-7). The magnet and the contacts have a common mounting plate. Because the mounting plate moves on the pivot pin, escape armature to escape wheel adjustments do not change other escapement magnet assembly adjustments.

Punch Clutch Magnet Assembly

- Allows the punch clutch shaft to turn with the drive pulley.

The punch clutch magnet assembly (Figure 2-8) controls the operation of the punch clutch. Compare this magnet assembly with the one for the card feed.

A piece of nonmagnetic material prevents the residual magnetism from sealing the armature to the magnet core, and ensures faster armature return.

The punch clutch armature (Figure 2-8) is metal, and has a rubber bumper at the pivot to aid in absorbing the shock when latching.

The magnet assembly is mounted with the pivot end of the armature next to the support bracket. A coiled spring is used to restore the armature.

Card Feed Latch Magnet Assembly

- Prevents the feed knives from moving.
- Operates the latch contacts.

Figure 2-9 shows a breakdown of the latch magnet assembly. When the register key is pressed, a card feed cycle is initiated, but the card feed latch magnet assembly suppresses card feeding by suppressing the cam follower arm operation.

The latch magnet yoke and the latch magnet armature are mounted on the same plate. The yoke is po-

sitioned with respect to the armature. The curved tip of the armature holds the cam follower arm inoperative when a card is being registered.

The card feed latch magnet assembly has a common mounting plate. To adjust the card feed latch magnet assembly, with respect to the cam follower arm, adjust the mounting plate. The latch magnet armature is restored by the latch contact operating strap. The card feed latch contacts are operated by the tail of the latch magnet armature.

Energizing the latch magnet attracts the armature, and its curved tip suppresses the cam follower arm operation. The tail of the armature transfers the latch contacts. The travel of the latch magnet armature is determined by the yoke and adjustable armature backstop. When the armature is restored, the tail of the armature rests on the adjustable backstop.

Backspace Mechanism

- Operates the backspace switch.
- Moves cards in reverse up to column 1.

The backspace mechanism (Figure 2-10) moves the program drum, master card, and detail card in reverse (*backspacing the card*). The detail station feed wheel, the master station feed wheel, and the program drum shaft are in the same gear train and each one is dependent on the other two.

The actuating arm controls the three functions performed by the backspace mechanism (two electrical and one mechanical). The backspace switch (a micro-switch) controls the two electrical functions: (1) restores the keyboard and (2) opens the control circuits. The third function is mechanically moving the cards and program drum in reverse, and is controlled by an ear on the actuating arm (*actuating arm ear*).

When the backspace key is pressed, the follower end of the cam engaging arm rides on the six lobe cam. The cam drives the backspace mechanism. The backspace pawl pivots on the tail of the cam engaging arm and they are both held against the actuating arm ear by springs. The backspace pawl pivot is mounted on the tail of the cam engaging arm, and when the backspace key is pressed, the backspace pawl cam and the cam engaging arm operate together. The six lobe cam pivots the cam engaging arm up and forces the backspace pawl down. As the cam engaging arm and the backspace pawl leave their home position, the arm is under control of the cam. The pawl pivots on the tail of the cam engaging arm and the single tooth hooks into a tooth of the backspace ratchet.

Downward movement of the pawl rotates the backspace ratchet clockwise. The ratchet has three elon-

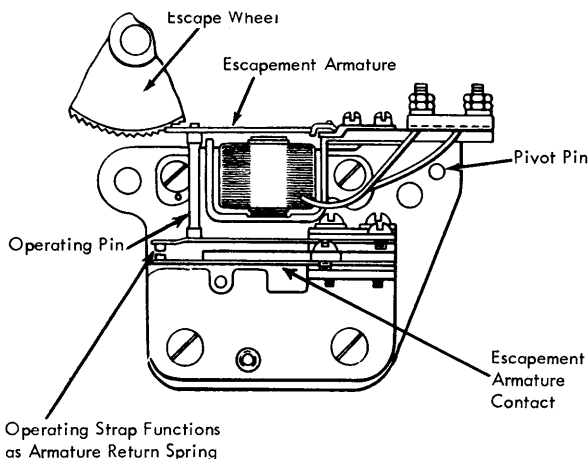

Figure 2-7. Escapement Magnet Assembly

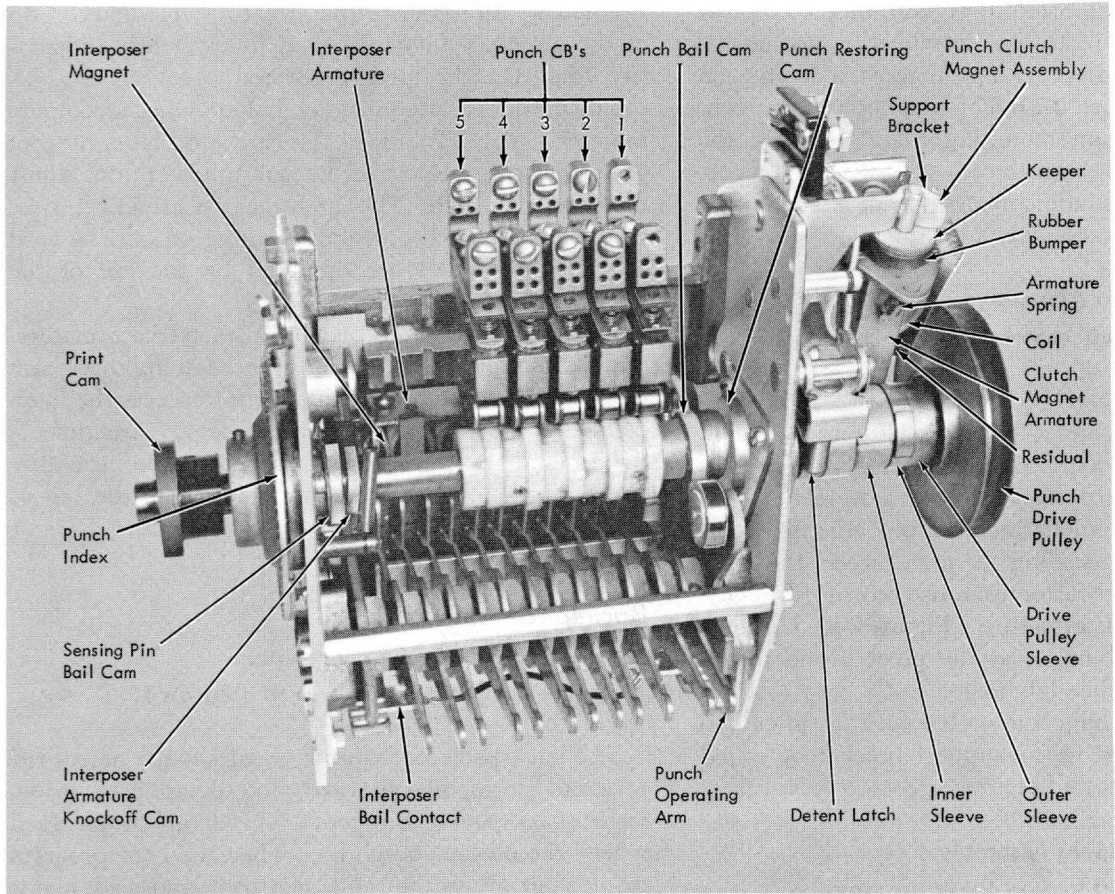

Figure 2-8. Punch Drive Unit

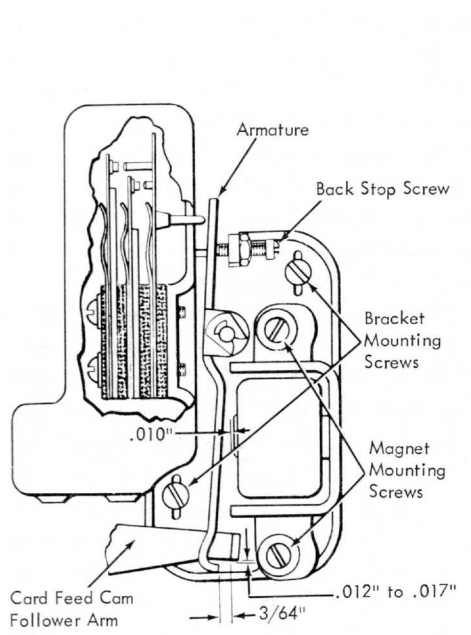

Figure 2-9. Card Feed Latch Magnet Assembly

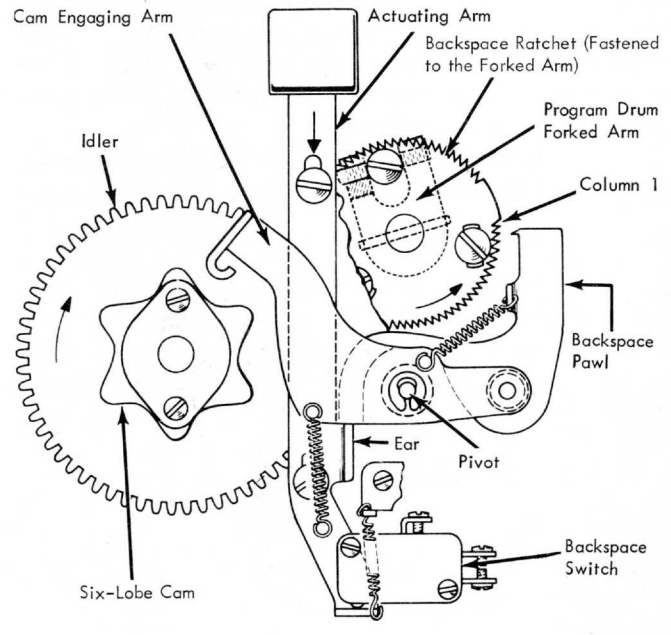

Figure 2-10. Backspace Mechanism

gated holes for mounting it to the program shaft forked arm. These elongated holes also facilitate the adjustment of the backspace ratchet in respect to the backspace pawl. The backspace ratchet is adjusted for pawl tooth to ratchet tooth overlap. Adjustment of the program shaft forked arm will not affect the pawl tooth to ratchet tooth overlap on the backspace mechanism.

The cam engaging arm going from low dwell to high dwell on the six lobe cam, must move the escape wheel a distance of $1\frac{1}{4}$ teeth with respect to the escape armature. The escape armature drops behind the escape wheel tooth and acts as a detent. Because the pawl is fastened to the forked arm, movement of the ratchet causes reverse movement of the entire escape mechanism.

The backspace pawl turns the backspace ratchet clockwise. When the arm drops into the low dwell of the cam, the tooth on the backspace pawl drags over a tooth on the backspace ratchet. In the same manner, the tip of the escape armature drags on a tooth of the escape wheel. The escape armature and the escape wheel teeth provide column-by-column escapement and detenting of the backspace mechanism for column-by-column backspacing.

Normal escapement turns the program drum from column 1 to 80. Normal backspacing can turn the program drum from 80 to 1, but the cards will not stay in registration for more than 20 columns.

Card Feed Mechanical Action

- **The card feed clutch initiates the feed cycle.**

When a feed cycle is initiated, the CF (card feed) clutch magnet is energized. This releases the tail of the dog and allows it to engage in the ratchet and rotate the clutch latch disk. The CF ratchet turns continuously on the horizontal CF shaft. The clutch latch disk is pinned to the shaft. In one CF cycle, the clutch latch disk and the horizontal CF shaft turn 360° .

The CF shaft drives the stacker unit and the CF unit. The stacker unit is driven from the stacker end (left) of shaft, and the CF unit from the hopper end (right).

The CF camshaft is driven by the CF shaft from the hopper end at a 1-to-1 ratio (one revolution of the clutch latch disk gives one revolution of the CF camshaft). The CF clutch dog is latched on the armature at 0° of the CF index gear. In one CF cycle, there will be a 360° rotation of the clutch latch disk, the horizontal CF shaft, and the CF camshaft. The CF index gear is pinned to the right end of the CF camshaft.

Figure 2-11 is a view of the right front side of the machine, the cam follower arm, the feed knives, and

the CF clutch magnet. The long spring in Figure 2-11 is the operating spring for the cam follower arm. The feed knives will move down when the cam follower arm goes on to the low dwell of the cam. The cam follower arm follows the CF cam under the force of the cam follower arm spring.

The feed knives are mounted on a common carrier that can move up and down in a porous bronze slide. When the feed knife carrier moves in the slide, the feed knives move.

Feed Knife Operating Link: The connecting link consists of two parts riveted together through elongated holes (Figure 2-11). This allows the link to change length as the force of its connecting spring is overcome. If the feed knives are jammed and the cam follower arm is being positively driven downward by the CF cam, the link will expand. This is a safety factor to prevent parts damage.

When the index leaves zero, the follower on the cam follower arm is riding on the fall of the CF cam. At this time the cam follower arm is operated by the force of the cam follower arm spring. At 83° of a CF cycle, the cam follower arm, under the force of its spring, has moved the feed knives to the fully operated position. At this point the follower is on the low dwell of the CF cam, and the link has reached the uppermost point of its travel.

Card Feed Latch Magnet: When registering a card, the curved tip of the card feed latch magnet armature controls the CF cam follower arm (Figure 2-12). The cam follower arm pivots on a bronze bearing and the front end operates the feed knives. The opposite end has a turned over ear to provide a latching surface for the CF latch magnet armature. When the CF latch magnet is energized, its armature will transfer the latch contact and prevent the cam follower arm from following the CF cam. This prevents feed knife operation.

Card Feed Index: The CF index is stamped on the CF index gear (mounted on the CF camshaft next to the CF cam), which drives the feed rolls (Figure 2-12).

Feed Rolls and Pressure Rolls: The feed knives move the card to the rubber feed rolls and steel pressure rolls (Figure 2-13). The rubber feed rolls are driven through an idler by the CF index gear.

Four steel pressure rolls (mounted to a support, that can pivot on a spring-loaded bar) run against the four rubber feed rolls. The feed rolls and their pressure rolls transport the card from the hopper to the detail bed.

Mechanical Timing Chart: Figure 2-14 shows the mechanical timing chart of the card feed knives. The timing chart shows the time that the feed knives actually contact the card and the time that the card

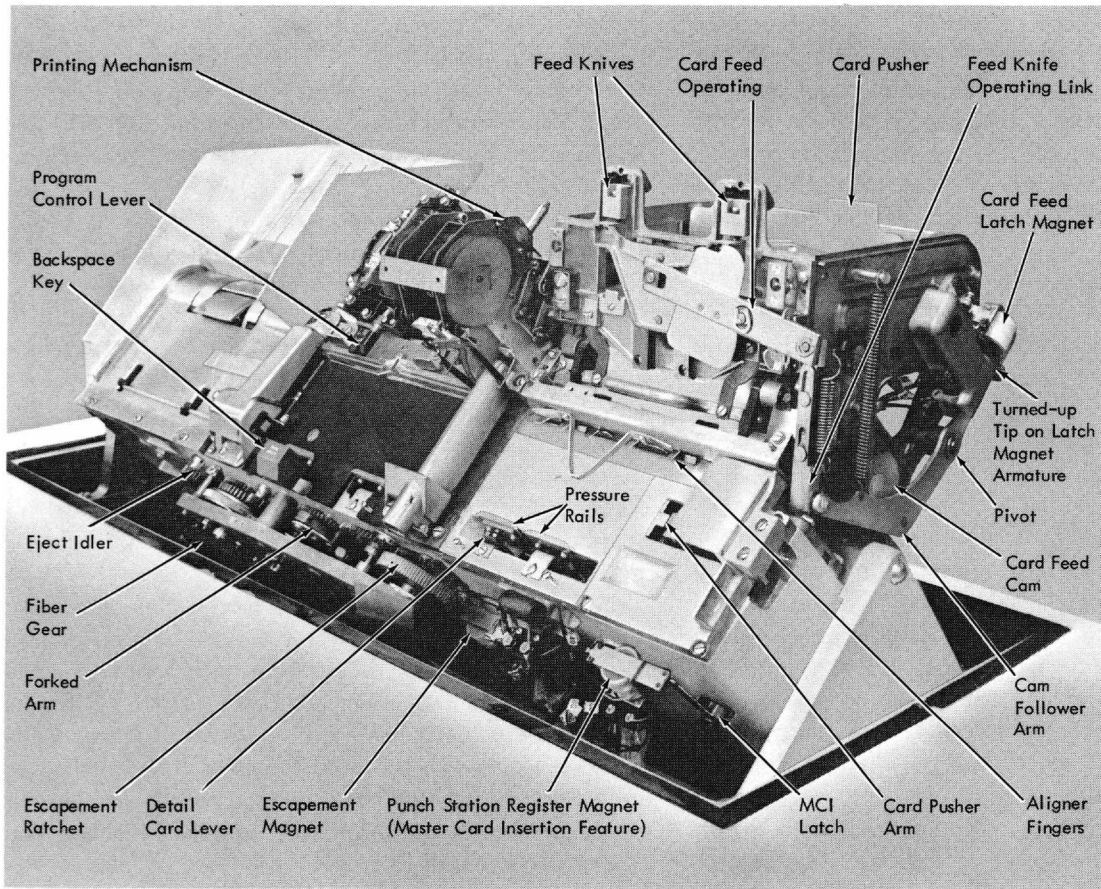

Figure 2-11. Card Feed Unit (Right Front View)

reaches the feed rolls. These timings are referenced to the *CR* index. The component listed in the left margin is in its normal condition when at the reference line. As it leaves its reference line starting at zero, it is being operated. As it returns to its reference line, it is being restored.

At 19° of a *CR* cycle, the card is moved by the feed knives and starts leaving the hopper. At 58° of a *CR* cycle, the card leaves the feed knives and enters the upper feed rolls to be transported to the detail bed.

Card Hopper and Feed Knives

- The hopper holds 500 cards.
- One card at a time can be fed.

To enable the feed knives to pick up a card on a *CR* cycle, the cards are pressed against the front of the hopper by the card pusher. With a full hopper (approximately 500 cards), the feed knives can feed cards to the feed rolls, but only one card at a time if the throat knife and block are correctly adjusted.

Cards in the hopper are held against the feed knives by pressure applied to the back of the cards from the card pusher. When the card pusher is moved to the rear of the hopper, a latch hooks onto a stud mounted in the hopper frame. The card pusher will remain to the rear of the hopper until the latch is released from the stud by the latch lever. The cards are held against the feed knives by tension from the adjustable coil spring in the card pusher.

Cards can be removed from the hopper by pushing the card pusher to the rear of the hopper until it latches. To place cards in the hopper, place the cards toward the front of the hopper, and squeeze the latch lever toward the card pusher plate to release the card pusher; this allows the card pusher to press against the cards.

The card is not in the detail station when it leaves the feed rolls. The action of the card aligner fingers and the card aligner cam complete the card movement to the detail station (Figure 2-15). When the card leaves the feed rolls, the card aligner fingers (operated by the card aligner cam) move the card down past the upper card rail.

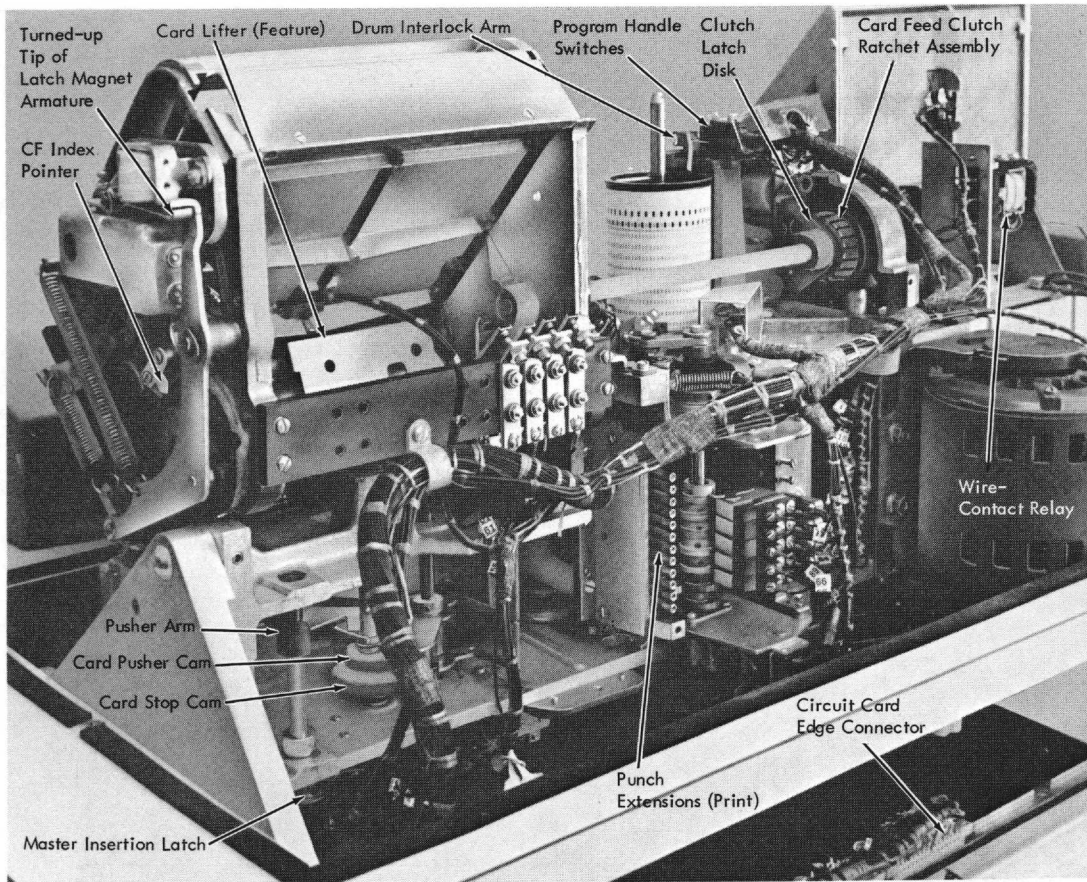

Figure 2-12. Card Feed Unit (Right Rear View)

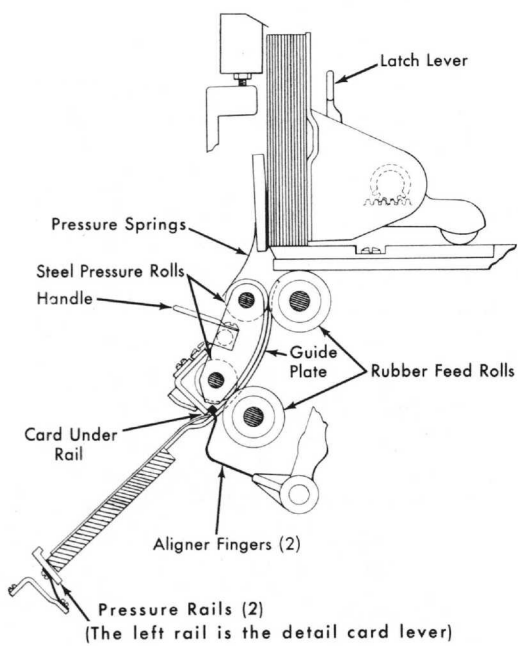
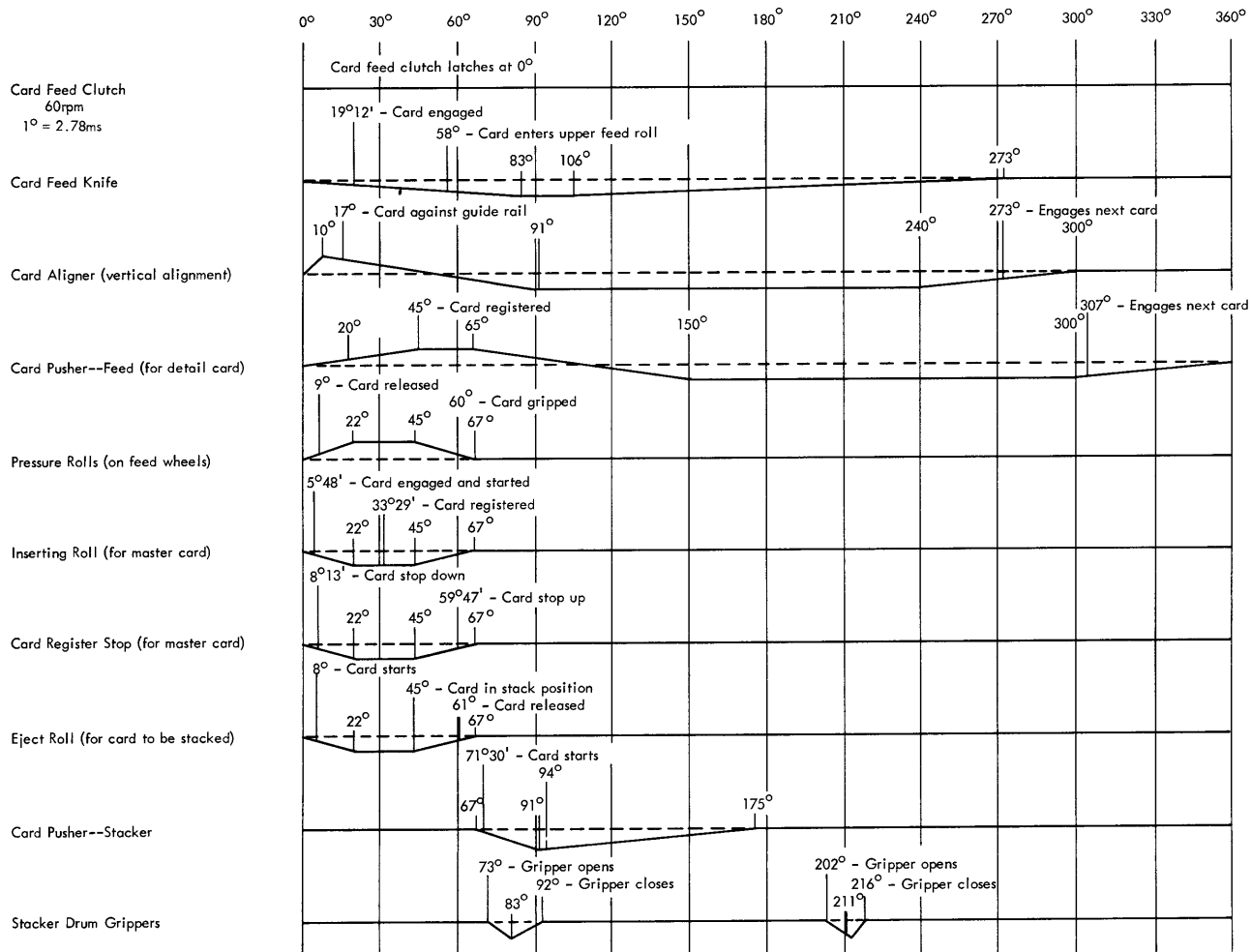

Figure 2-13. Card Feeding

Card Feed Mechanism



Punch Mechanism

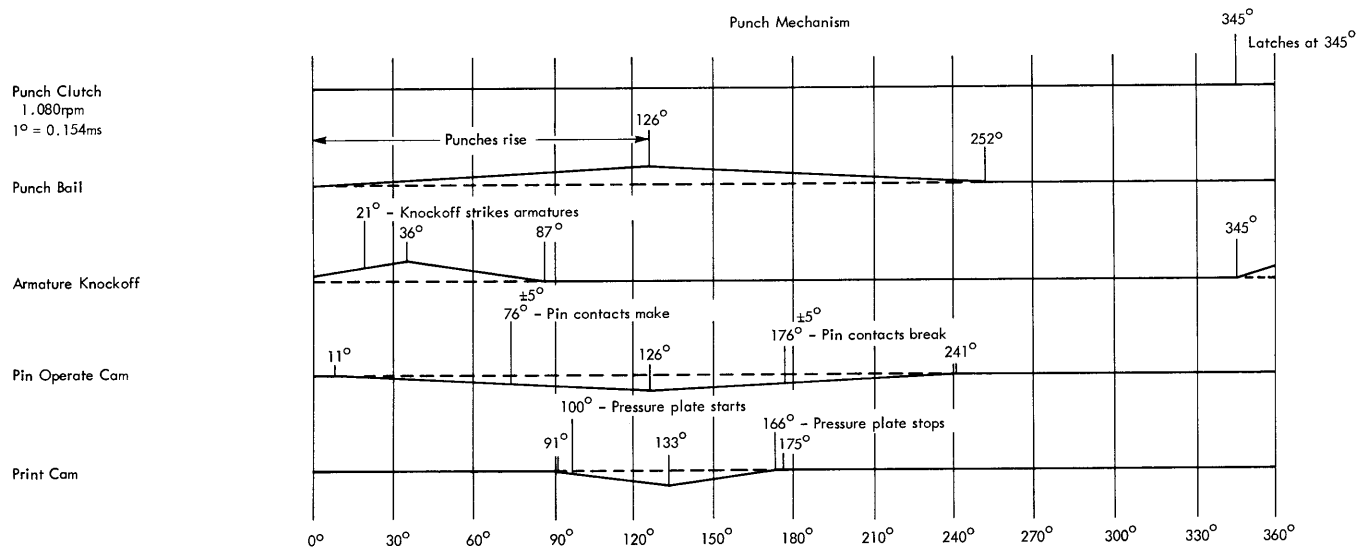

Figure 2-14. Mechanical Timing Chart

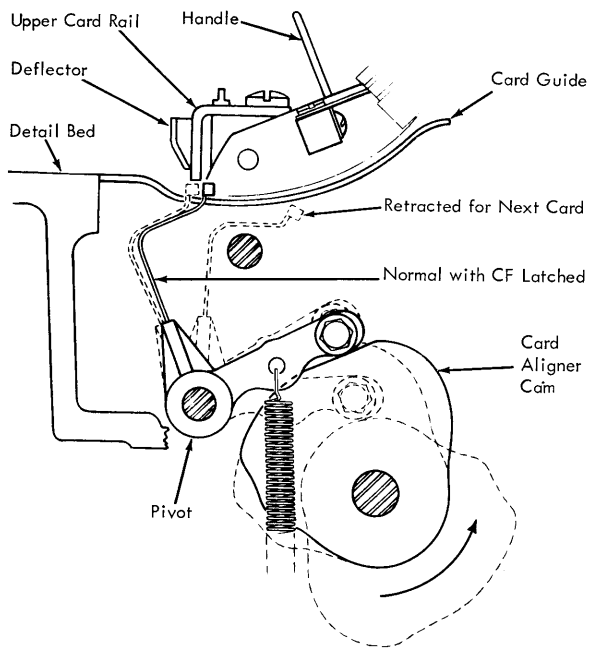

Figure 2-15. Aligner Fingers

Card Registration Mechanics

- **Cards move into correct alignment for reading and punching.**

Figure 2-16 shows the card stop and pusher cams on the card pusher camshaft. This shaft is driven at 1-to-1 ratio by the CF camshaft. The stop cam operates the stop lever cam arm, and the pusher cam operates the card pusher arm. The stop lever cam arm lifts the pressure roll as the card is being pushed by the card pusher arm. To register a card at the read and punch stations in correct synchronism, the card pusher camshaft must be timed with respect to the CF index. The card at the detail station is registered from the column 80 end by the card pusher cam (Figure 2-17).

The following is the mechanical sequence of feeding a card from the hopper to the detail station and registering another card at the punch station (refer to Figure 2-14):

1. At 19° of a CF cycle, the card in the hopper is engaged by the feed knives.
2. At 10° of the next CF cycle, the card is at the detail station and at its lowest point of travel. The card is under control of the card aligner fingers.
3. At 17° of this second CF cycle, the card contacts the upper guide rail because of the cut of the card aligner cam.
4. At 20°, the card (now at the detail station) is under the control of the card pusher arm.

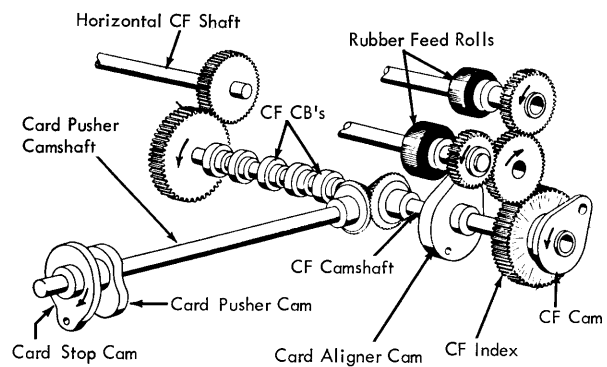

Figure 2-16. Card Pusher Camshaft

5. At 45°, the card is registered by the card pusher arm at the detail station.

6. Between 0° and 45°, the card is moved out from under the upper card rail by the card aligner fingers and is registered by the card pusher arm.

When a card is registered at the read and punch stations, the cards are spaced column by column. The cards are under control of the escape mechanism and moved by the feed wheels.

Pressure Roll Linkage and Card Registration

- **Pressure rolls under spring tension hold the cards against the feed wheels.**
- **The two pressure rolls are the master pressure roll and the detail pressure roll.**

Both pressure rolls are lifted at the beginning of a CF cycle by the card stop cam to enable a card to be registered (Figure 2-18). Lifting the master pressure roll operates the entire eject unit. Linkage and levers transfer motion from the card stop cam to the (adjustable) pressure rolls. The stop lever cam arm, release pin, release pin arm, and manual release lever are the linkage and levers that lift the pressure rolls.

The manual release lever is accessible without removing any covers (Figure 2-18). By pressing the manual release lever, an operator can remove a card from either station without removing the other card.

The read and punch pressure rolls (adjustable) turn on studs, and the axis on which the pressure rolls rotate moves when adjusted. Figure 2-19 shows three possible positions obtainable through this adjustment. The pressure rolls aid the feed wheels in the column-by-column movement of the cards. Horizontal card movement changes if the pressure roll axis is changed.

When registering a master and detail card in column 1, the cards should still be in registration when reaching column 80, if the pressure rolls and pressure rails are functioning correctly.

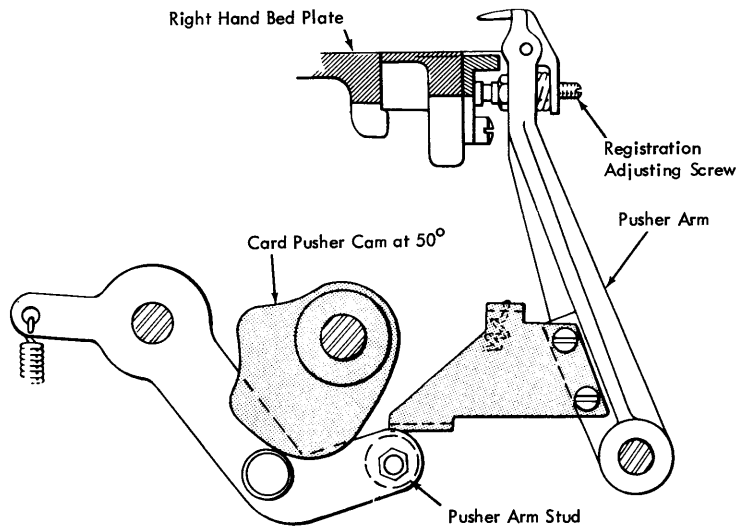
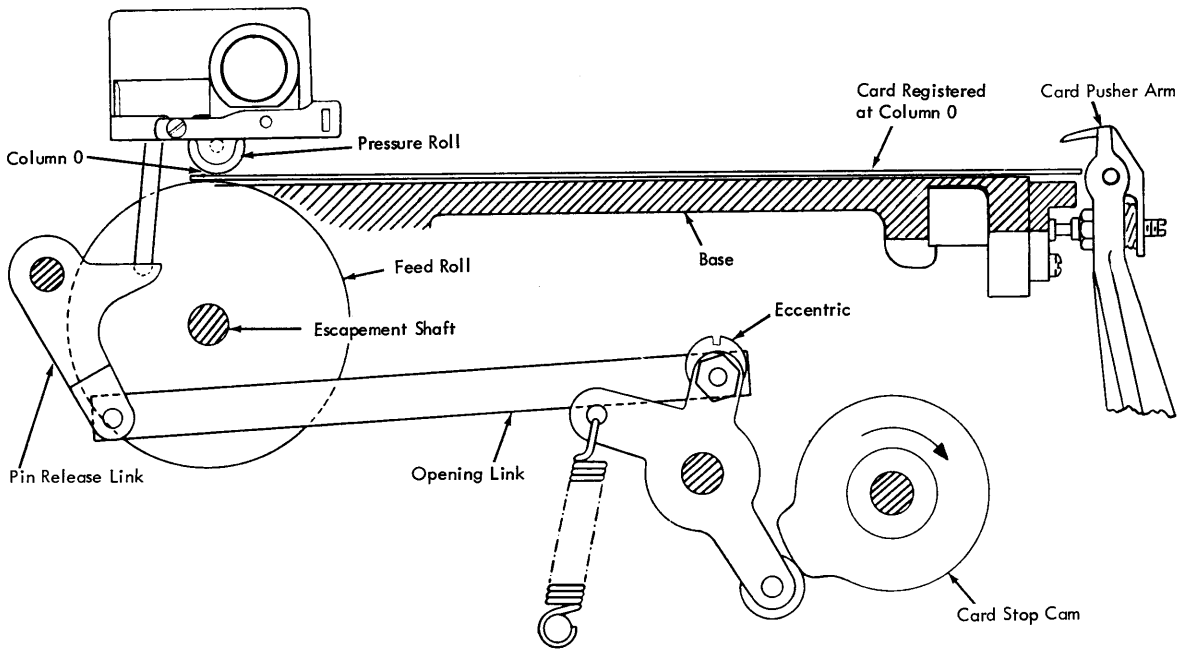

Figure 2-17. Detail Card Registration

A card registered at the punch station is in the correct position with respect to the punches. A card registered at the read station is in the correct position with regard to the sensing pins. For a card to remain in registration during column-by-column movement through the punch station, the card must be up against the upper card rail; to remain in registration during column-by-column movement through the read station, the card must be up against the left upper card rail.

With cards in the hopper, the card aligner fingers move the card down from under the upper card rail and into the detail card station on the first portion of the *CR* cycle. The card pusher arm pushes the card along the upper card rail and into the punch station for registration.

The registration pressure roll is lowered onto the continuously running feed roll to move a card into the read station for registration. When the registration

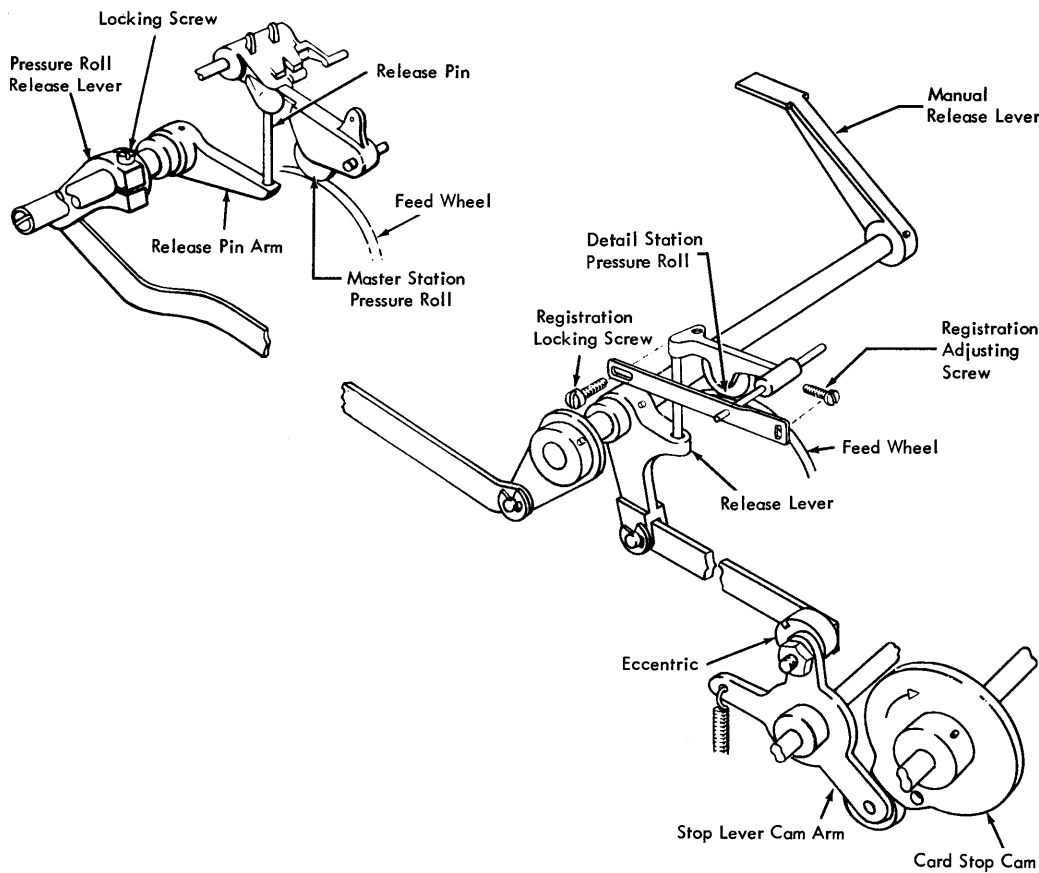

Figure 2-18. Pressure Roll Linkage

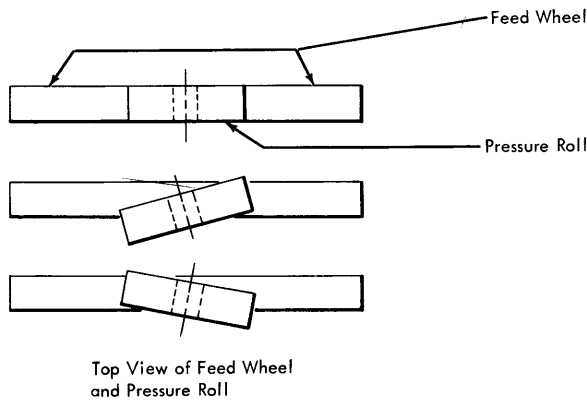

Figure 2-19. Pressure Roll Alignment

eject lever is operated, the registration and eject pressure rolls are lowered simultaneously onto the continuously running feed rolls (Figure 2-20).

Registration Stop Plate

- The stop plate stops the card being moved into the read station.

- The stop plate determines the horizontal position of the card when it is registered at the master station.

The stop plate shown in Figure 2-21 is in a fully operated position: through the card line, and the card resting squarely against its side. The spring shown in Figure 2-21 holds the stop plate against the throat plate. The stop plate is lowered by the spring and is under control of the registration eject lever.

During a CF cycle, the registration eject lever goes up. Idler lever action then moves the register lever down and the stop plate moves along with the lever. During the CF cycle, the idler lever pivots as the register lever goes down, and lowers the stop plate through the card line.

The throat plate is the upper surface of the read station opening and is a part of the registration and eject mechanism. The throat gap is determined by the distance of the throat plate from the card bed. The throat gap is between 0.012" and 0.018". Adjust this by placing shims between the throat plate and its mountings on the registration and eject mechanism.

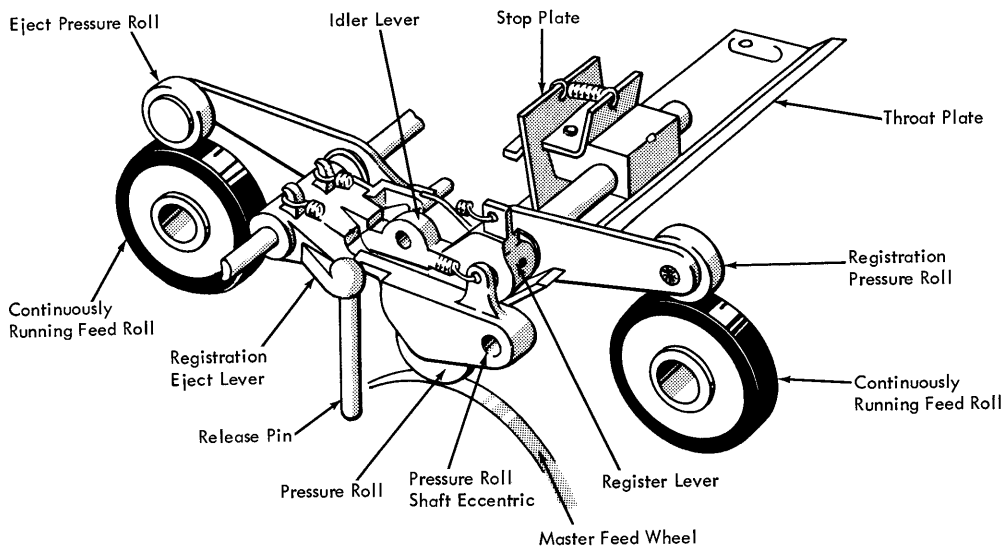

Figure 2-20. Registration and Eject Mechanism

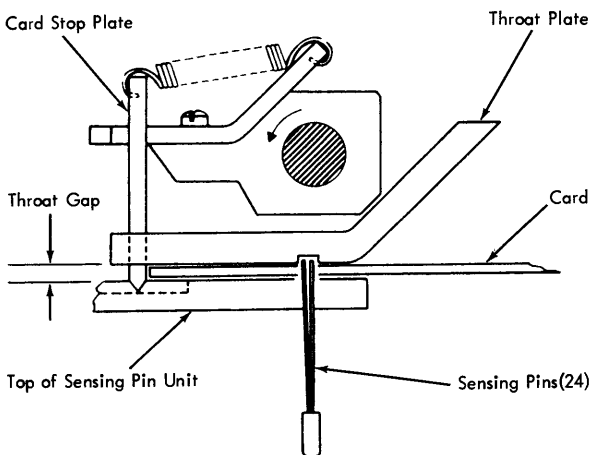

Figure 2-21. Registration (Read Station)

When the sensing pins are operated, they push the card up against the throat plate. The throat plate is now functioning as an upstop for the card at the master station. When a feed cycle occurs, the stop plate is lowered and drags on the end of the card being ejected. After the card is ejected, the stop plate is through the card line and is hit squarely by the card being registered. The vertical position of the card registered at the read station is determined by the stop plate.

Lifting the registration eject lever lifts the master pressure roll, ejects a card, moves a card into the master station, and lowers the stop plate to register a

card. The timing of the four functions of the registration and eject mechanism is determined by the length and arrangement of the levers. Worn parts (such as levers) in the register and eject mechanism can change the timing of all four functions.

Stacker Assembly

- The stacker assembly is driven by the CF clutch through an idler gear.
- One stacking cycle occurs for every CF cycle.

After a card has been ejected, it is pushed by the card pushers and guided by the traveling card guide. The pushers and card guide, components of the stacker assembly, control the card and transport it to the gripper fingers (Figure 2-22).

The stacker cam, mounted on the stacker drum, turns one complete revolution for each stacking cycle (Figure 2-22). The card pushers and the traveling card guide are both operated by the stacker cam via links and levers. The gripper fingers pivot on studs mounted on the stacker drum.

The two components that transport the card to the gripper fingers are the card pushers and the traveling card guide.

When the card is transported to the gripper fingers, the fingers grip the card (by spring tension) as it is transported from the card pusher to the stacker bed by the stacker drum. Stationary cams open the gripper fingers when a card is to be received from the card

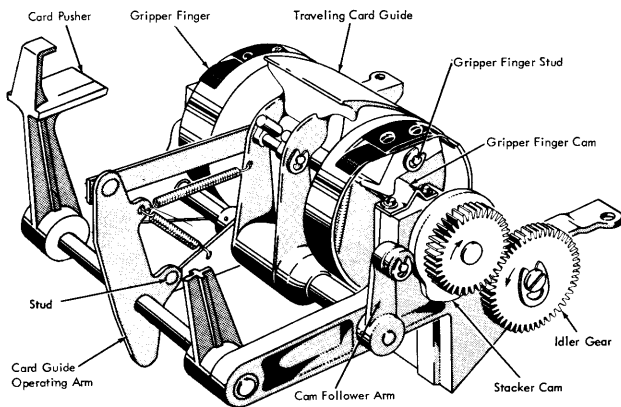

Figure 2-22. Stacker Assembly

pusher. These cams, called gripper finger cams, also open the gripper fingers when the card is delivered to the stacker bed.

There are four stationary gripper cams; two are used to open the gripper fingers to receive the card, and two to open the gripper fingers when delivering a card to the stacker bed.

The traveling card guide also aids in card registration.

Card Lever Contacts

- There are two card lever contacts:
 1. Detail card lever contact (left pressure rail in detail station.)
 2. Read card lever contact (left pressure rail in master station).

The left pressure rail in both the master station and the detail station operate as card lever contacts. The detail card lever contact closes on the second card feed cycle when a card is registered at the punch station (about 10° of the card feed cycle).

The card lever contacts are actuated by the pressure of the card against the pressure rail. A card passing through the detail or master station closes the contact. Closing of the card lever contacts by the card lever signals the machine that a card is in the punch or read station.

Card Feed and Punch Circuit Breakers

- Two types of circuit breakers (CB) are used:
 1. The card feed (CF) CB consists of a stationary contact and an operating arm operated by a CF CB cam.
 2. The high-speed (HS) CB consists of a laminated, stationary contact and spring cam follower operated by a punch (P) CB cam.

The CB's provide timed electrical impulses of a definite duration under the control of the CB cam and camshaft speed.

Figure 2-23 shows the make and break of the CF CB's (card feed circuit breakers). The contacts make while the cam roller rides on the low portion of the cam, and they open when the roller rides on the high portion.

Figure 2-23 also shows the punch CB. This CB is a high-speed plunger type. The laminated stationary contact and the cam follower spring reduce the bouncing of the contact points at high speed. This CB is designed to stand the 1,200rpm speed of the punch shaft. The cam follower roller strikes the lobe of the cam and moves upward. This upward motion, which is transmitted to the plunger through the cam follower spring, closes the contact.

Keyboard Mechanics

- The keyboard mechanism converts a manual key depression into an electrical impulse.
- The keyboard interlocks so that an operator can press only one key at a time.
- The two basic units in the keyboard are the permutation unit and the key components unit.
- Some keys perform an electrical and mechanical function, and some keys perform only an electrical function.

The principles of operation are the same for the numeric and combination keyboards.

Figure 2-24 shows the combination keyboard with the cover removed and disassembled into two major units (key components unit and permutation unit). The key unit contains all the keys. The alphabetic key, numeric key, multipunch key, program 1 key, program 2 key, feed key, error reset key, and duplicate key perform only electrical functions. These keys operate the keystem contacts (Figure 2-24).

Figure 2-25 shows one latch pull bar, one bellcrank, one latch, and one permutation bar. All the keys, except those operating the keystem contacts, operate a latch pull bar through a keystem bellcrank.

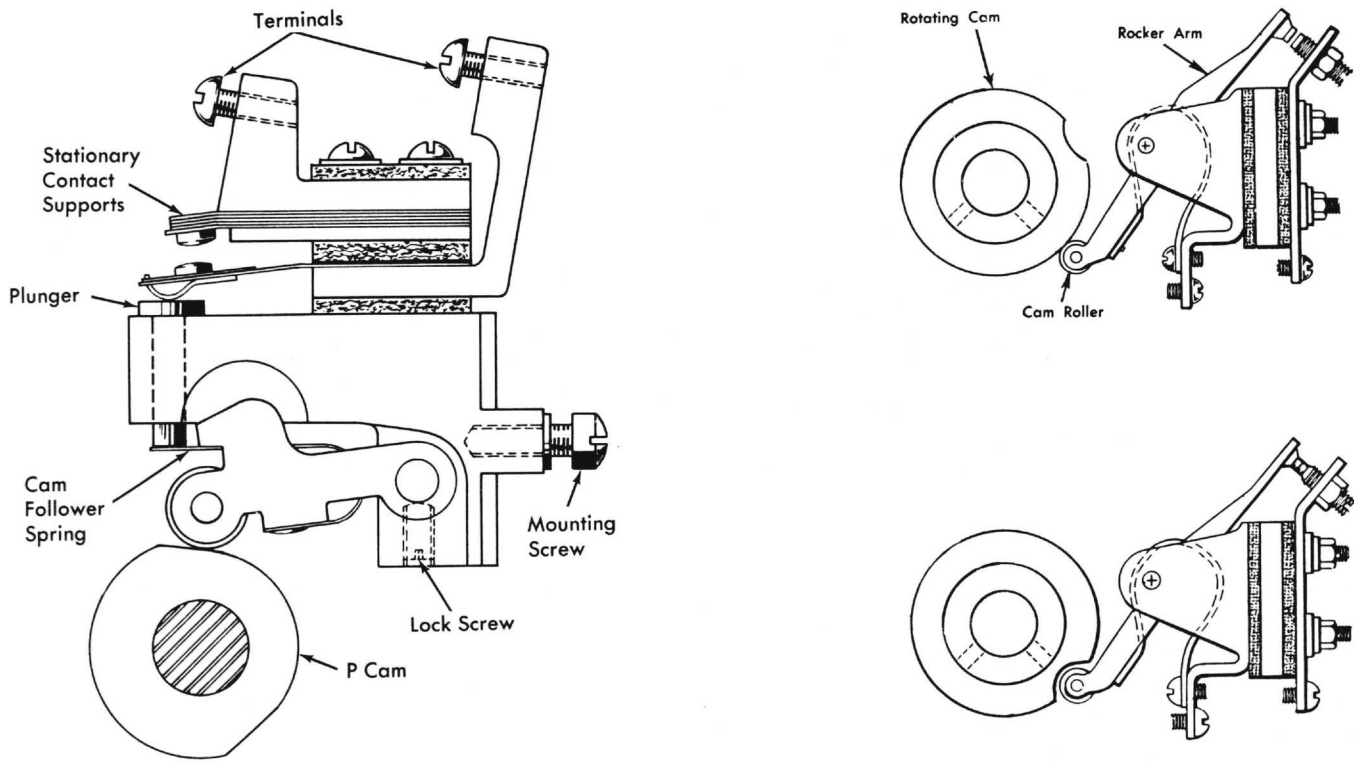

Figure 2-23. CB's (Circuit Breakers)

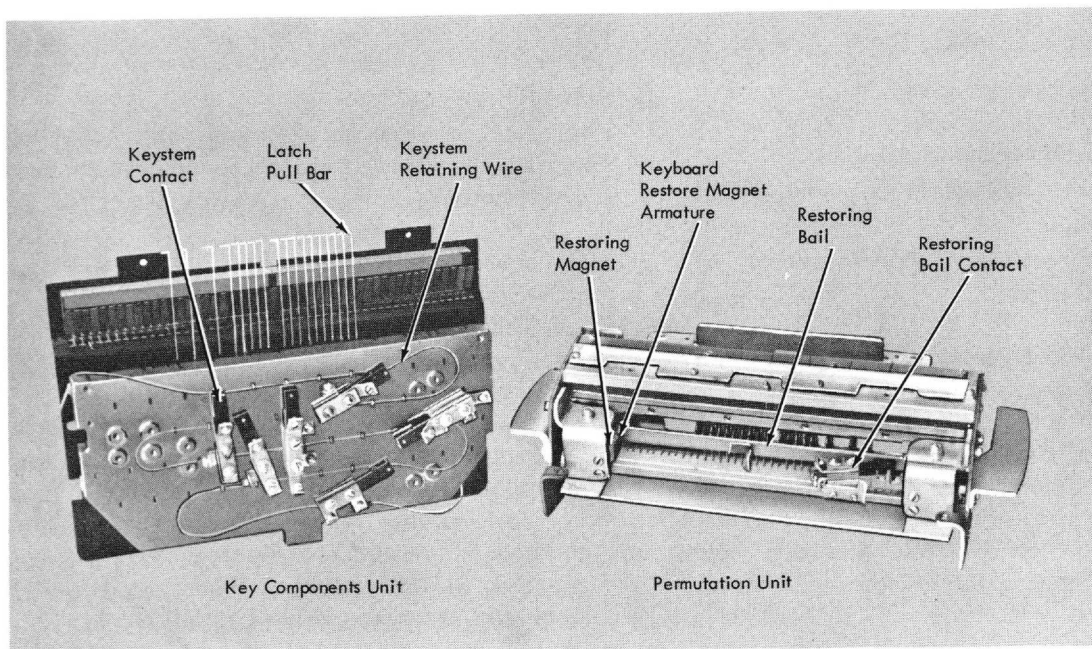

Figure 2-24. Keyboard Units

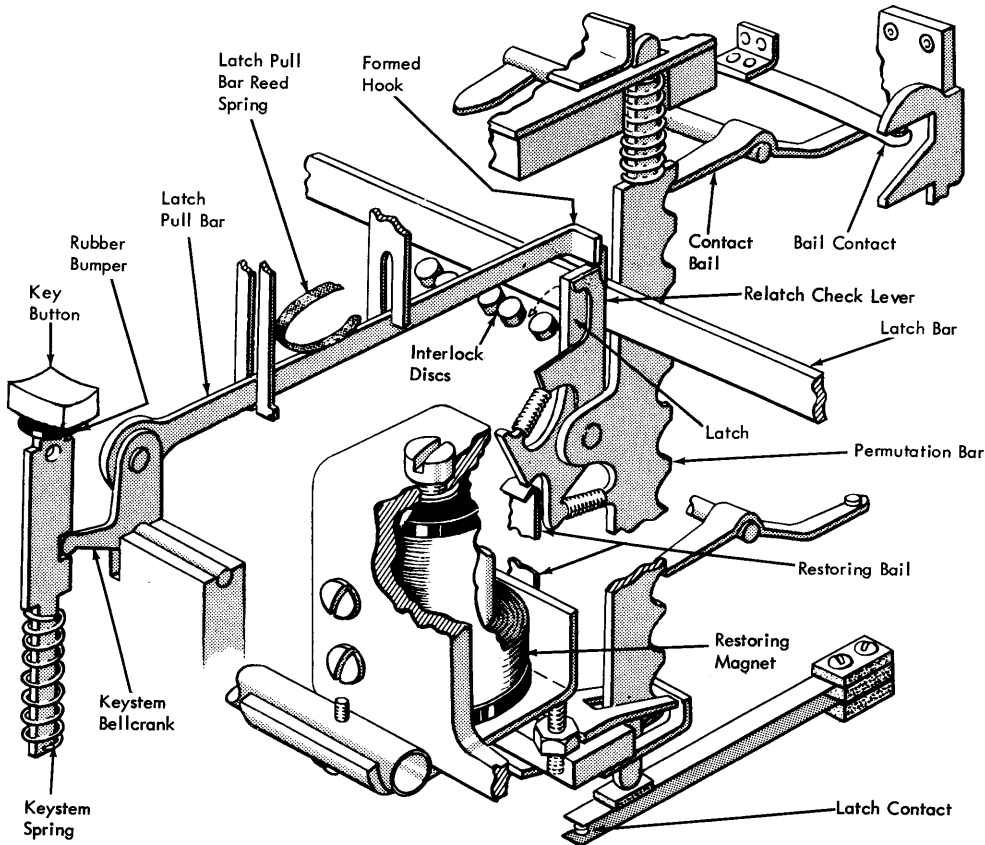

Figure 2-25. Key Position

For details of keyboard electrical functions, refer to Appendix B.

The rubber bumper, a rubber washer under the key, is associated with the keystem. The amount of downward travel by the key is partly determined by the thickness of the rubber bumper. As a key is pressed, the bellcrank pivots and moves the latch pull bar toward the keystem. The hooked portion of the latch pull bar rests in a notch in the top of the latch (Figure 2-25). When a keystem is pressed, the latch pull bar pulls the latch off the latch bar. The keystem is restored by a spring.

The mechanical operation when pressing a key is (Figures 2-25, 2-26, and 2-27):

1. The keystem bellcrank moves the latch pull bar forward.
2. The latch assembly drops off the latch bar.
3. Individual keystem springs restore the keys and the pull bars to normal.
4. A flat spring holds each pull bar against the latch assembly for relatching.

Figure 2-27 shows that the latch assembly has three parts that, although attached by a rivet, are free to pivot. Each part has its own function.

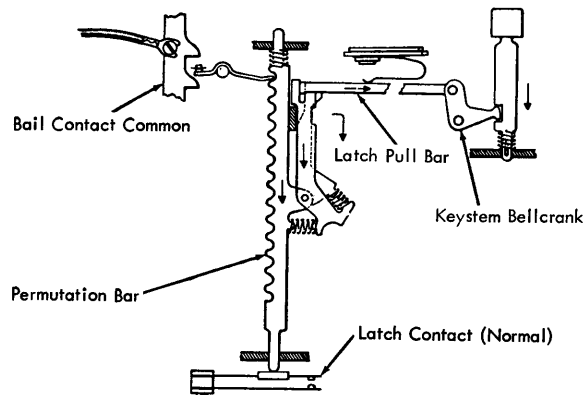

Figure 2-26. Permutation Bar and Keyboard Latch (Normal)

The permutation bar is contained in the permutation unit of the keyboard. The permutation bar supports the operating spring, and pivots to close the bail contacts. Some permutation bars operate latch contacts via a latch which pivots on the permutation bar. The latch pull bar has a 90° hook formed at one end which rests in a notch cut into the top of the latch. The bar is held in the notch by the U-shaped reed spring.

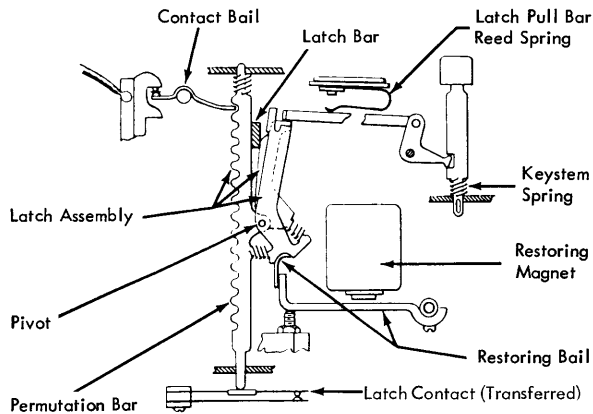

Figure 2-27. Permutation Bar and Keyboard Latch (Tripped)

The purpose of the key unit is to facilitate selection of individual characters and, after selection, to operate a permutation bar. *Permutation* means transformation or change in grouping. In the keyboard, the operation of the latch and bail contacts is under control of the permutation bars. The latch hooks over the latch bar, and holds the latch assembly and its permutation bar inoperative until a key is pressed. The permutation bar transfers the bail contact and a latch contact (Figure 2-27) necessary to punch the correct character. When the latch is hooked onto the latch bar, the spring-operated permutation bar is held restored. When the latch is pulled off the latch bar, the permutation bar is then operated by the force of the spring.

The function of the permutation bar requires it to move, and this movement is guided by the upper front guide rail and the latch stop plate at the bottom. The lower end of a permutation bar, when operated, transfers a latch contact.

Bail and Latch Contacts

- **These contacts are operated by permutation bars to energize the correct circuit for each character.**
- **Fifteen bails span the width of the keyboard.**
- **Bails, when pivoted, transfer a bail contact.**
- **A latch contact is transferred by its permutation bar.**

The contact bail (pivoted by a tab attached to the bail) rests in a notch cut in the front edge of a permutation bar. A permutation bar has 15 notches cut in its front edge for operating any of the possible 15 contact bails.

A keyboard reference chart, located in the wiring diagram on Systems 00.29.10.0, shows the combination

of latch contacts and bail contacts needed to punch a desired character. Odd-numbered bail contacts are on the right side of the keyboard, and even-numbered bail contacts are on the left side of the keyboard (as viewed from front of keyboard).

Figure 2-28 identifies the keystem numbering of both the numeric and combination keyboards. Pressing any one key can never transfer more than one latch contact, but more than one bail contact may be transferred. Latch contacts are mounted on the keyboard lower frame directly under their corresponding permutation bar.

Keyboard Restoring Components

- **The keyboard is restored by two magnets operating a bail.**
- **Pressing a key pulls a latch off the latch bar.**
- **The latch is restored to the latch bar by the restoring bail.**

The restoring bail operates a normally closed bail contact. When the keyboard restoring magnets are energized, the restoring bail restores the bail to the latch bar, and the restoring bail contact is opened.

Figure 2-29 shows the latch and relatch check levers in two different positions. The large over-all drawing shows the latch on the latch bar (restored), and the inset view shows the latch off the latch bar (tripped). The latch and relatch check levers pivot on a stud on the permutation bar. The latch is held on the latch bar by the force of a spring; the relatch check lever is operated by a spring. If the pull bar does not disengage from the latch as the latch is pulled off the latch bar, more than one punch cycle could occur for each key pressed.

When the latch is pulled off the latch bar (Figure 2-29 inset), the relatch check lever pivots toward the latch bar. The pull bar disengages from the latch because it cannot follow the latch downward. The pull bar cannot engage in the slot again until the latch and pull bar have both been restored. A key can be pressed and held pressed while the latch is pulled off the latch bar and restored to the latch bar, and the pull bar will re-engage in the latch only if the key is restored. When a latch is pulled off the latch bar, the pull bar engaging slot is covered by the relatch check lever.

The permutation bar is restored (with the latch) by the latch restoring bail. Energizing the restoring magnets operates the restoring bail and opens the restoring bail contact. The restoring bail is attached to the armatures of the keyboard restoring magnets. In every keyboard, two restoring magnets operate one restoring bail which restores the latch to the latch bar.

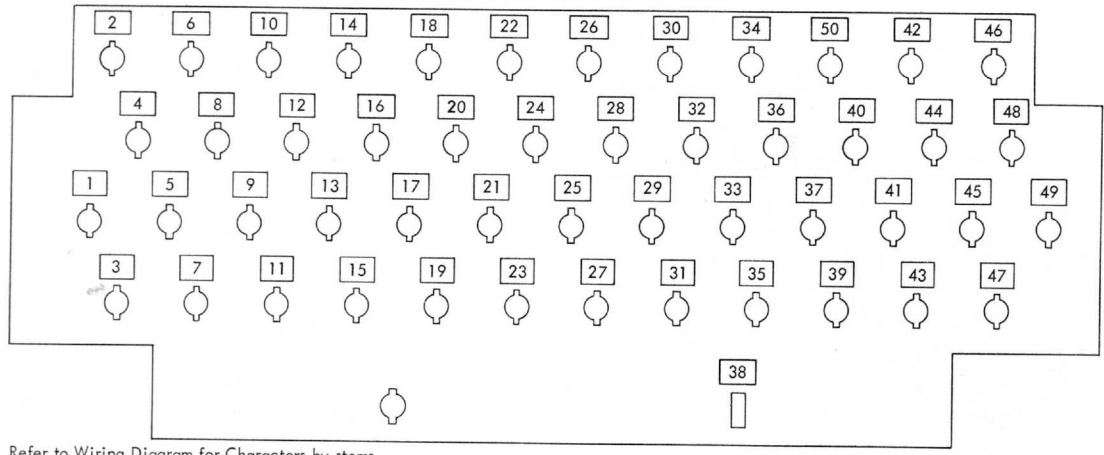
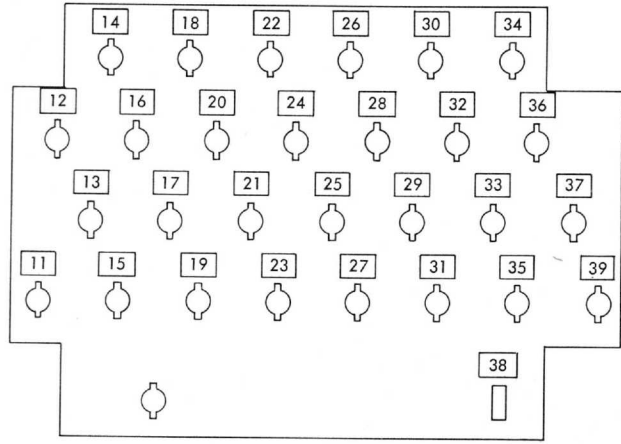

Refer to Wiring Diagram for Characters by stems.

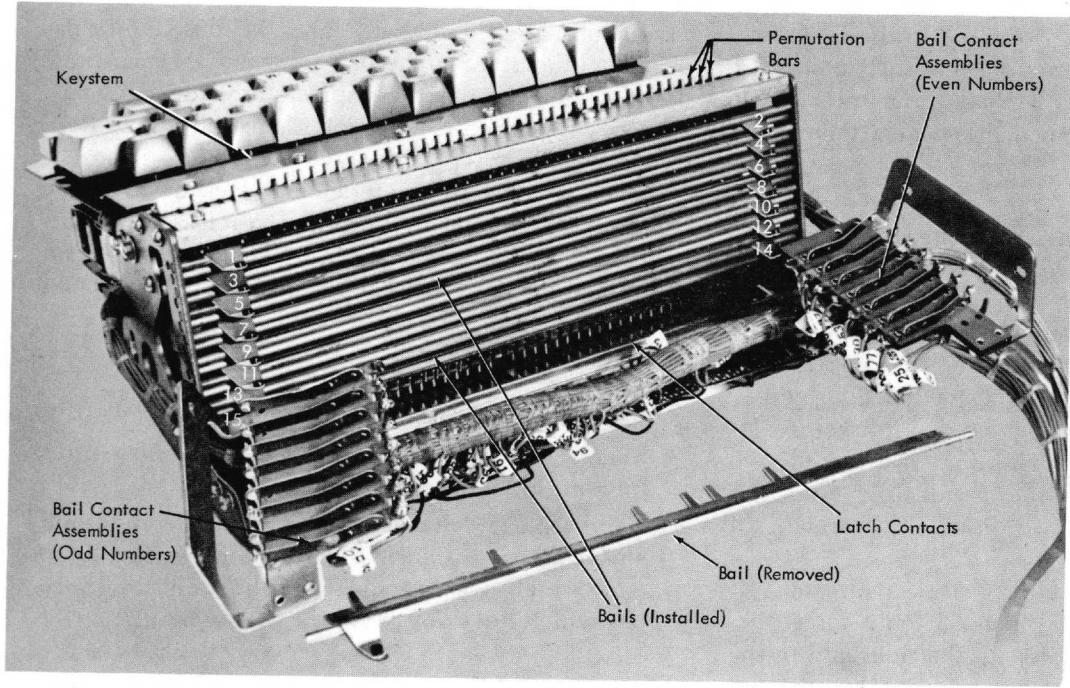

● Figure 2-28. Permutation Unit and Keystem Numbering Chart

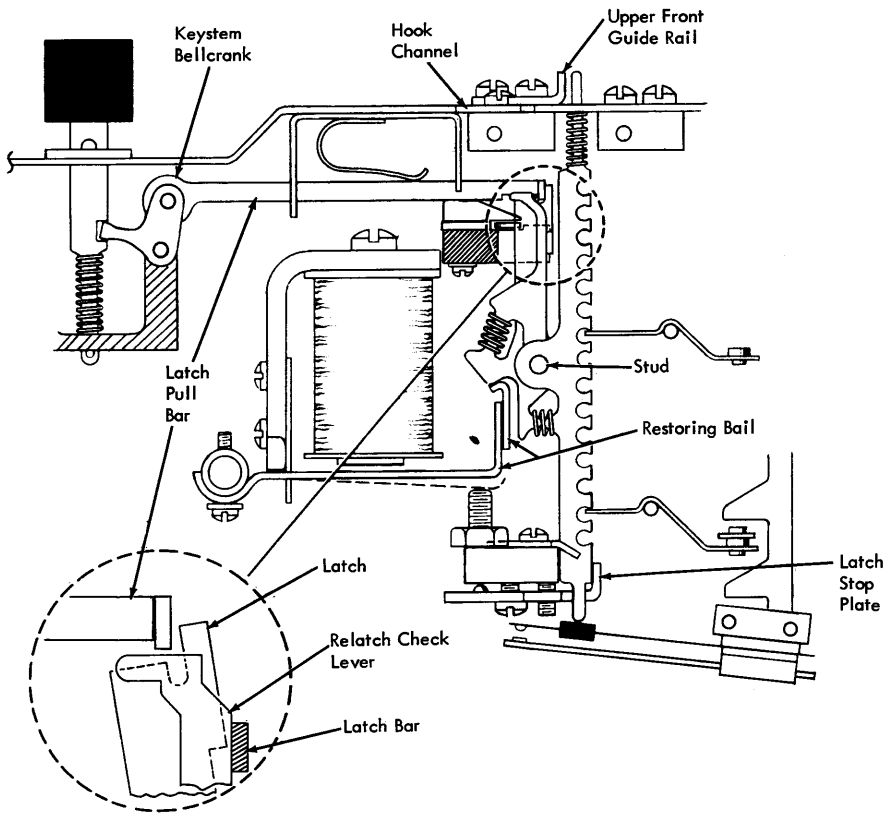

Figure 2-29. Key Position (Latched and Tripped)

The keyboard contains several latch contacts and 15 bail contacts, but only one restoring bail contact. The opening of the keyboard restoring bail contact signals that the latch has been restored to the latch bar. For correct keyboard operation, only one latch at a time can be pulled off the latch bar, thus preventing the operation of more than one key at a time.

Keyboard Interlocks

- **Interlock disks prevent more than one key at a time from being pressed.**

Figure 2-30 shows the interlock disks and the trough in which they are contained. The permutation bars and their latch assemblies are positioned side by side at equal distances apart. The interlock disks are located between each latch. The disks are placed side by side in the trough, and the line of disks spans the row of latches. Any time two disks are separated, all the disks are moved.

Figure 2-31 shows five interlock disks with latch "B" first between two of them. When a latch is forced between any two disks, the disks to the right and to the left of it are moved. Figure 2-31 shows a key pressed and latch "B" pulled off the latch bar. Before latch

"B" could be restored, the operator pressed the key for latch "D." Latch "D" cannot be pulled off the latch bar until latch "B" is restored.

When a latch is operated and the disks are separated, all the other latches are inoperative because the interlock disks cannot be spread any further apart. When a key is pressed, the latch must be restored before another key is pressed.

When a keyboard is interlocked (locked) it can be restored (unlocked) by pressing the release key. This key has a section cut away in its latch so that it can be pulled off the latch bar regardless of the position of the interlock disks.

Special Character Codes (Combination Keyboard)

- **Special character codes are punched codes other than alphabetic or numeric.**
- **Eight special characters are possible in alpha shift; 23 in numeric shift, including the 0-2-8 code which has no logical graphic, and the space bar which does not punch or print (blank).**

The multipunch key can be used along with the digit keys to allow more than one punch in a column. When

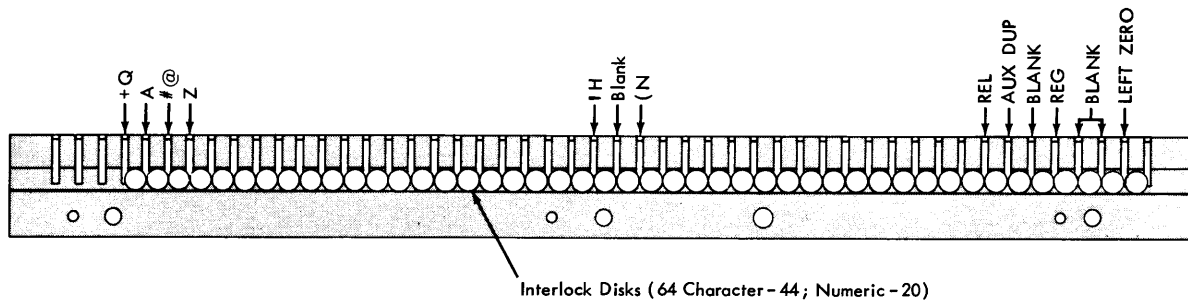

Figure 2-30. Interlock Disks

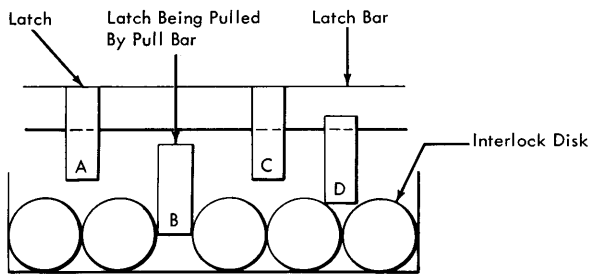

Figure 2-31. Interlock Disks

the multipunch key is pressed, the card punch is always in numeric shift. If either the "A" or "Z" key is pressed along with the multipunch key, the keyboard locks up and does not punch. (Pressing the multipunch key places the keyboard in numeric shift.) See "Appendix B" for details of keyboard operation.

Punch Drive Mechanics

- The punch drive unit is driven by a V-belt continuous drive through the punch clutch.
- The punch clutch is engaged for all punching and pin sensing operations.
- Punching and reading can take place simultaneously.

Figure 2-32 shows an exploded view of the helical-spring punch clutch. With no force applied to the free end of the spring, the coils on the end of the shaft grip the shaft with some force. By applying a counter-clockwise rotational force to the free end of the spring, the spring grips the shaft with more force. A clockwise rotational force will increase the diameter of the spring, and the spring will grip the shaft with less force.

The clutch drive pulley is continuously turning on a bearing on the end of the punch shaft. The drive pulley sleeve, part of the clutch drive pulley, runs con-

tinuously. The enlarged portion of the punch shaft has the same diameter as the outside diameter of the drive pulley sleeve. When the drive pulley sleeve is placed on the punch shaft, the punch shaft is up against the enlarged portion of the drive pulley sleeve.

The free end of the clutch spring grips the drive pulley sleeve, and the other end is secured to the punch shaft. The clutch spring has a smaller diameter than the drive pulley sleeve. One end of the spring is under the adjustable spring collar and is secured to the punch shaft by the collar. The clutch spring is manually turned clockwise so that the drive pulley sleeve can be assembled on the punch shaft. The free end of the clutch spring goes over the drive pulley sleeve, and its diameter is smaller than the diameter of the drive pulley sleeve. When the clutch spring is allowed to return to normal, it grips the drive pulley sleeve.

Three conditions exist until the free end of the clutch spring is released:

1. The clutch spring is held unwound.
2. The clutch drive pulley is continuously running.
3. The punch shaft is not turning.

When the free end of the clutch spring is released, it seeks its normal diameter, grips the drive pulley sleeve, and the clutch shaft turns with the clutch drive pulley.

The clutch sleeve slides over the clutch spring and, when turned clockwise, allows the spring stop to rest against the free end of the spring. The clutch sleeve performs the function of unwinding the clutch spring.

Figure 2-32 shows the punch clutch assembly and an inset view of the punch clutch magnet. The clutch sleeve is a split sleeve, having an inner portion and an outer portion. The inner portion of the sleeve and a collar clamp the clutch spring to the clutch shaft; the outer portion operates on the free end of the clutch spring.

Both the inner and outer portions of the clutch sleeve latch on the armature tip. The punch clutch magnet assembly is positioned with respect to the

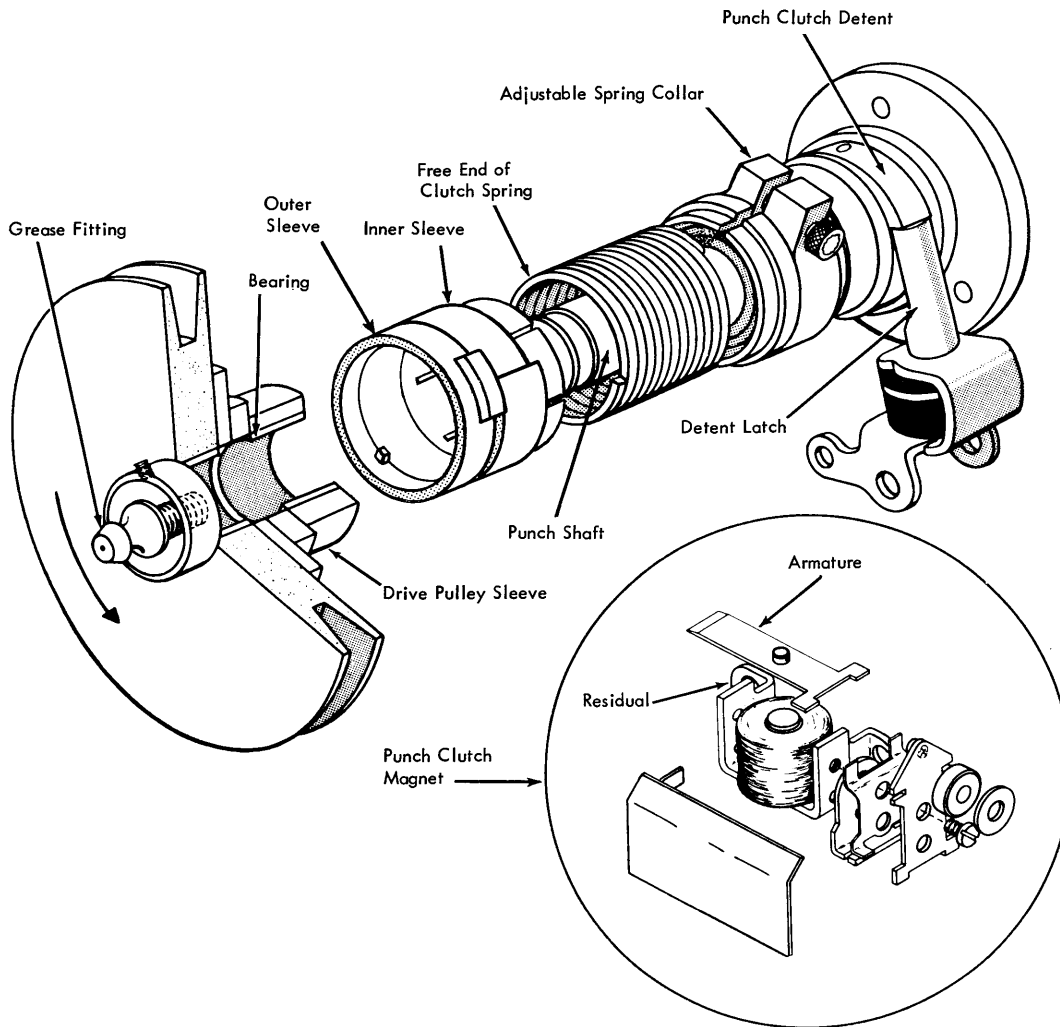

Figure 2-32. Punch Clutch Assembly

clutch sleeve. With the punch clutch magnet de-energized, the tip of the armature rests against the raised step on the outer sleeve, and the clutch is latched. The raised step engages the armature tip ahead of the raised tip on the inner sleeve (at the end of a punch clutch cycle), removing the gripping action of the spring on the drive pulley sleeve.

When the clutch magnet is energized, the clutch sleeve turns and allows the clutch spring to seek its normal diameter to grip the drive pulley sleeve. When the punch clutch magnet is energized for an instant, the armature is attracted and the punch clutch drives the punch drive unit one complete revolution. When the clutch sleeve latches on the tip of the armature, the punch drive unit stops and the index is at 345°.

For a clutch to be properly latched, it must be detented. Clutch overthrow is the amount (in degrees) the punch shaft can turn, with the clutch latched, to

allow the detent latch to drop behind the detent. To make sure the detent latch is behind the detent when the clutch latches, allow 1° to 3° overthrow.

Punch Drive Unit

- **The punch drive unit (Figure 2-33) operates the punch mechanism and the sensing pin mechanism simultaneously.**

The punch drive unit is driven by the continuously running clutch drive pulley via the punch clutch. Figure 2-34 shows the punch shaft and the different cams mounted on it. The punch clutch drive pulley is on one end of the shaft, and the index is on the other. The mechanical motion in the punch drive unit is derived from the punch shaft. The amount of mechanical motion and the timing of the motion is determined by the cams mounted on the punch shaft. The front part

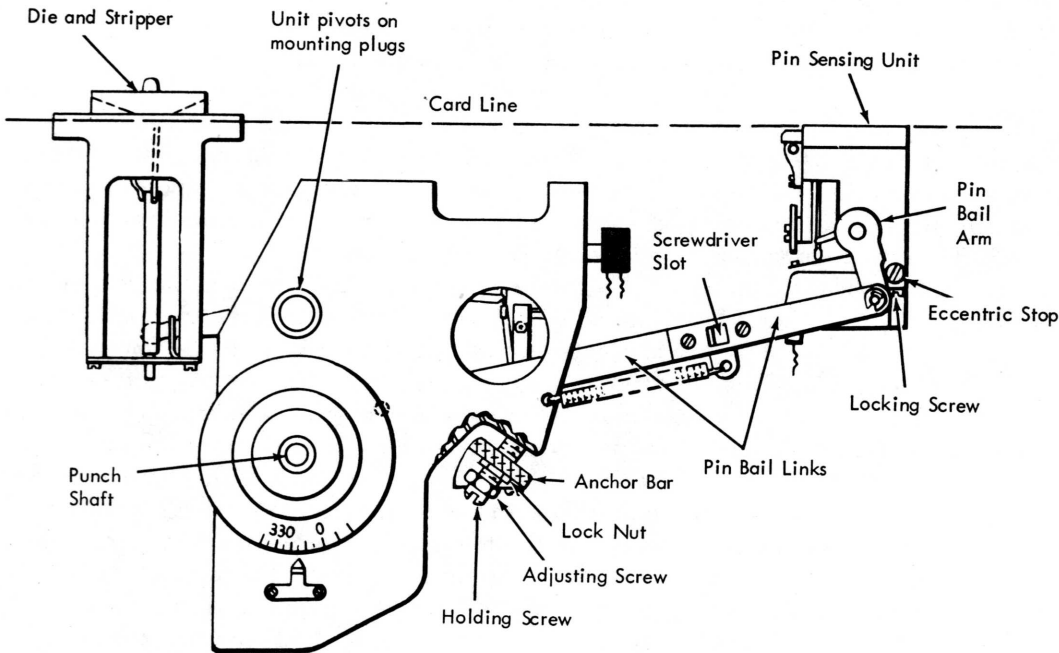
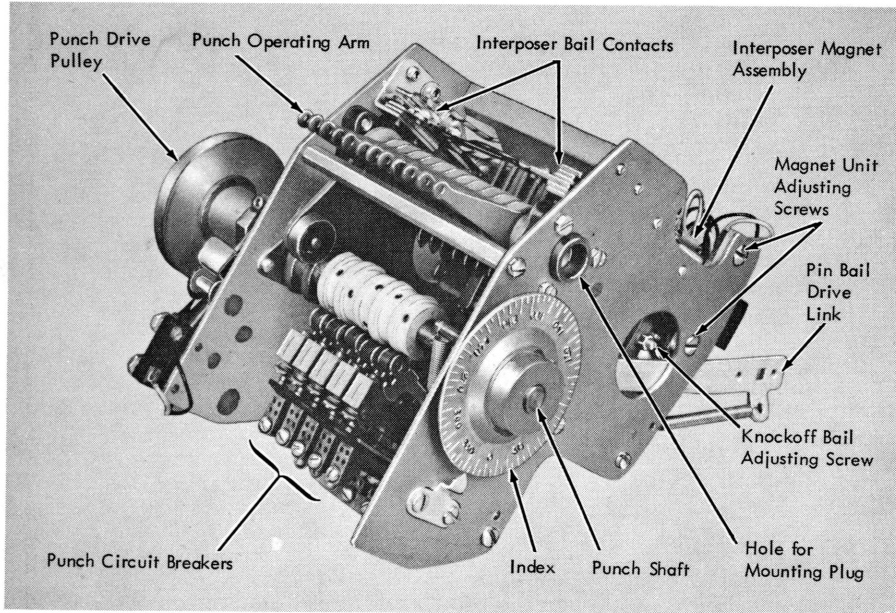

Figure 2-33. Punch Drive Unit

of the punch shaft (on the outside of the drive unit frame) contains the continuously running punch drive pulley, the punch clutch, and the detent.

One cam on the punch shaft is the punch restoring cam; a second cam is the punch bail cam. These two cams control the rocking action of the punch bail and are identified as *complementary* cams because they work together (one cam performing the first portion of a function, and the other the remainder). The next

five cams (P-cams) on the punch shaft operate the high-speed circuit breakers. The interposer armature knockoff cam operates the interposer armature knock-off bail. The last cam on the punch shaft is the sensing pin bail cam.

A knockoff bail, operated by the interposer armature knockoff cam and mounted on the punch shaft, ensures that the armatures in the interposer magnet assembly are restored.

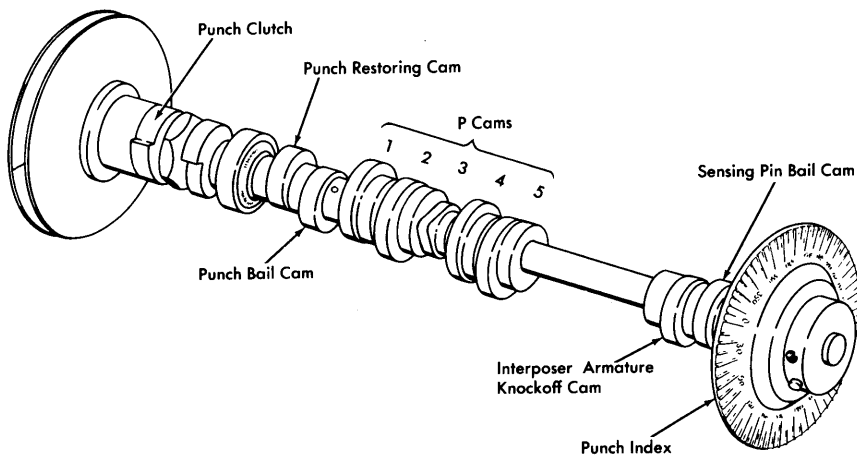

Figure 2-34. Punch Shaft Assembly

For each punch cycle, the cams and the punch shaft turn 360°. The names of the cams on the punch shaft identify the function they perform in the drive unit. (*Example:* The punch bail cam operates the punch bail.) The punch bail and the punch operating arms pivot (on the same shaft) either together or independently.

Figure 2-35 shows one punch position in the punch drive unit. On the left end of the punch operating arm is an interposer that pivots on the arm and is held with spring tension against the punch bail. The bail end of the interposer resembles a hook. The interposer spring holds the interposer against the bail, and also holds the interposer hooked on the bail.

Punch Operating Arm

- **Actuates the punch extension for punching and printing.**

The punch operating arm and the punch bail can operate independently or together. When the interposer is hooked on the bail, the punch operating arm and the punch bail are operated together by the punch shaft. With the interposer held away from the bail, only the punch bail follows the punch shaft.

In one punch cycle, the punch bail completes one cycle of operation. The interposer is hooked on the bail and the punch clutch magnet is energized for an instant. The punch bail and the punch operating arm complete one cycle of operation.

Figure 2-35 shows the end of the punch operating arm resting in a slot in the punch extension. In one punch cycle, the punch operating arm moves the punch and the punch extension through one complete cycle of operation.

When the punch interposer magnet is not energized:

1. The interposer armature holds the interposer away from the bail.
2. The punch operating arm does not move.
3. The punch extension does not move.
4. The punch does not move.

There are 13 interposer magnets, one for each possible punch, and one for spacing. To space, the machine goes through a punch clutch cycle without punching. Figure 2-36 shows the interposer magnet assembly with a number on each armature showing which interposer it controls.

The latching surface of the armature can be seen in Figure 2-35. Each interposer magnet armature has a slot cut near its operating end. With the magnet assembly positioned properly with respect to the interposers, a de-energized magnet allows the tip of its respective interposer to rest in the armature slot; the other end of the interposer is not hooked on the punch bail. When an interposer magnet is energized and the armature is attracted, the interposer is free to pivot on the punch operating arm under the force of the interposer spring. When the interposer is unlatched from its armature, it pivots and hooks on the punch bail, and the punch bail and the punch operating arm go through a complete cycle of operation. Near the end of a punch cycle, when the punch operating arm is approaching its home position, the tip of the interposer strikes the interposer armature and latches. When the interposer magnets are de-energized, the interposers are latched on the armatures. A punch operating arm, traveling with a punch bail during a punch cycle, has its interposer hooked on the punch bail. With a card at the punch station, an interposer magnet energized, and the punch clutch magnet energized, the card will be punched.

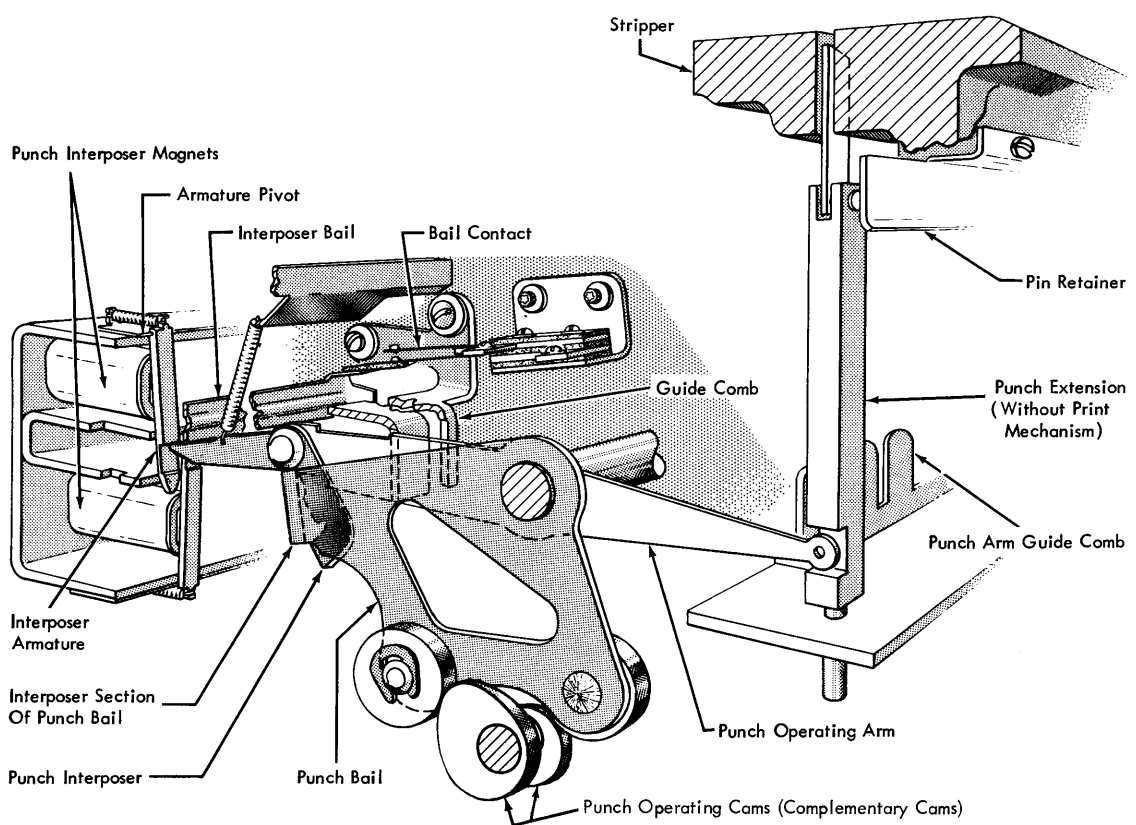
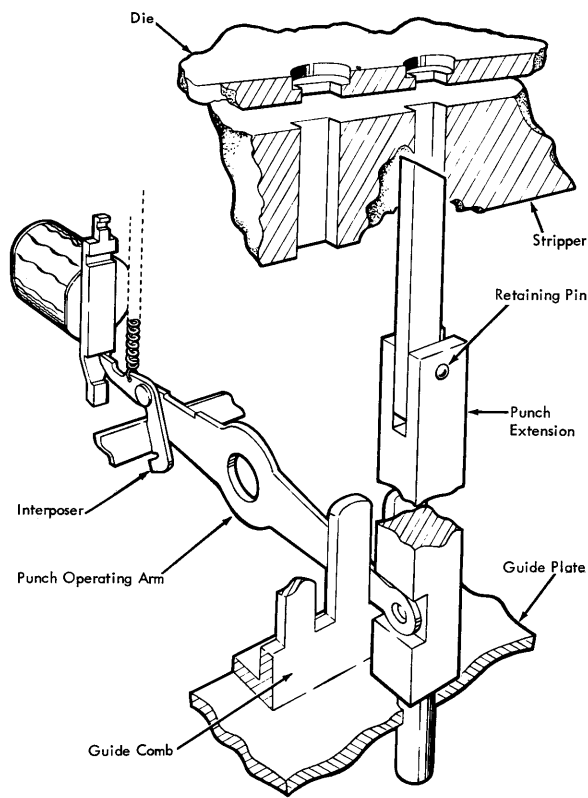

Figure 2-35. Punch Drive Unit Operation

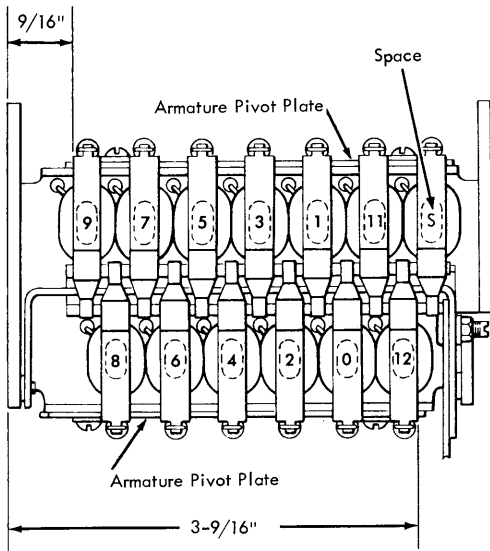

Figure 2-36. Interposer Magnet Armatures

Interposer Bail Contacts (Two Used)

- The interposer bail contacts energize the keyboard restore, escape, and punch clutch magnets.

Above the tips of the interposers is an interposer bail which spans the entire complement of interposers (Figure 2-35). When a punch interposer is unlatched from its armature, it pivots and its tip strikes the interposer bail. The two interposer bail contacts (Figure 2-33) on the inside of the drive unit frame, are operated by the interposer bail. Unlatching any interposer operates the interposer bail, and the bail closes the interposer bail contacts.

Space Interposer

- The space interposer closes the interposer bail contacts, causing an escapement and punch cycle.

To move a card at the punch station one column without punching it, the card must be spaced. The punch drive unit has a space interposer, but because no holes are punched when spacing a card, the space interposer has no punch operating arm. The space interposer operates the interposer bail to close the interposer bail contacts (Figure 2-37).

Twelve interposer magnets cause punching by latching their punch interposers on the punch bail. The thirteenth magnet in this unit is the space interposer magnet, the purpose of which is to close the interposer bail contacts and cause an escapement-and-punch cycle. The punch cycle is needed to restore the space interposer and to open the bail contacts again.

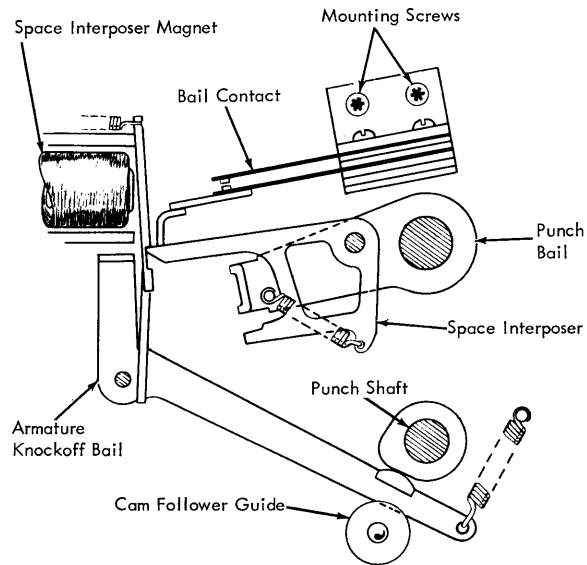

Figure 2-37. Space Interposer and Armature Knockoff Bail

Energizing Interposer Magnets

- The interposer magnets can be energized by the sensing pin contacts at the read station, or a key from the keyboard.

An interposer can be unlatched from its armature by energizing its interposer magnet through a circuit in the pin sensing unit or the keyboard.

Closing the interposer bail contacts completes a circuit to energize the escape magnet. The escape magnet pulls the escape armature away from the escape wheel and closes the escape armature contact. This allows the card to escape one column. The escape armature contact completes the circuit to energize the escape interlock relays which in turn energize the punch clutch magnet. Effectively, the interposer bail contacts cause the clutch magnet to become energized after the card has escaped.

Before the card is punched, a series of events takes place to energize the punch clutch magnet:

1. Pressing a key closes a latch contact; or via sensing pin contacts.
2. The desired punch interposer magnet is energized.
3. The interposer magnet armature unlatches its associated punch interposer.
4. The interposer latches on the punch bail, and closes the bail contacts.
5. As the interposer bail contacts close, the escapement magnet is energized.
6. The escapement magnet armature contact picks up the interlock relays.

7. Interlock relay contact points energize the punch clutch after the card escapes to the column to be punched.

At 21° of a punch cycle, the armature knockoff bail strikes the interposer armatures; at 36°, the bail is at its uppermost point in the cycle and the armatures will be restored. The interposer magnet armatures are restored from 36° of the punch cycle until the interposer magnet is energized again to start another punch cycle. At 126° of a punch cycle, the punch operating arm has operated its punch to the uppermost point in the cycle (see Figure 2-14). At 126° of a punch cycle, the pin operating cam has raised the sensing pins to the uppermost point in the cycle.

It is impossible to sense a punch at the read station and punch it into the card at the detail station during the same cycle. The sensing pins move up to sense the card at the read station at the same time the punches at the punch station are moving up to punch a card.

When duplicating a hole in a card, the sensing of the hole at the read station always occurs the cycle before punching. The sensing of a punch at 76° energizes an interposer magnet, which allows its interposer to unlatch from its armature and mechanically store

the sensed information for the remainder of the cycle. On the next cycle, the mechanically stored information is punched.

Punch, Die, and Stripper

- **The punch, die, and stripper (located under the ejector housing) perform the single function of punching.**

Figure 2-35 shows a cross-sectional, side view of the punch operation at the punch station. A card registered at the punch station is between the die and the stripper. The die is on the top of a card registered at the punch station, and the stripper and punch are below the card. As a punch rises, it penetrates the card and a hole is punched by a scissor action as the punch enters the die. When a punch is restoring, the card is stripped from the punch by the stripper.

The punches are ground on an angle so that the chips sandwich in the die and are held from falling back onto the card. The chip ejector housing is mounted to, and on top of, the die. As the chips build up in the die, they go into the chip ejector housing.

Figure 2-35 shows the punch and the punch extension located with respect to the stripper and the guide

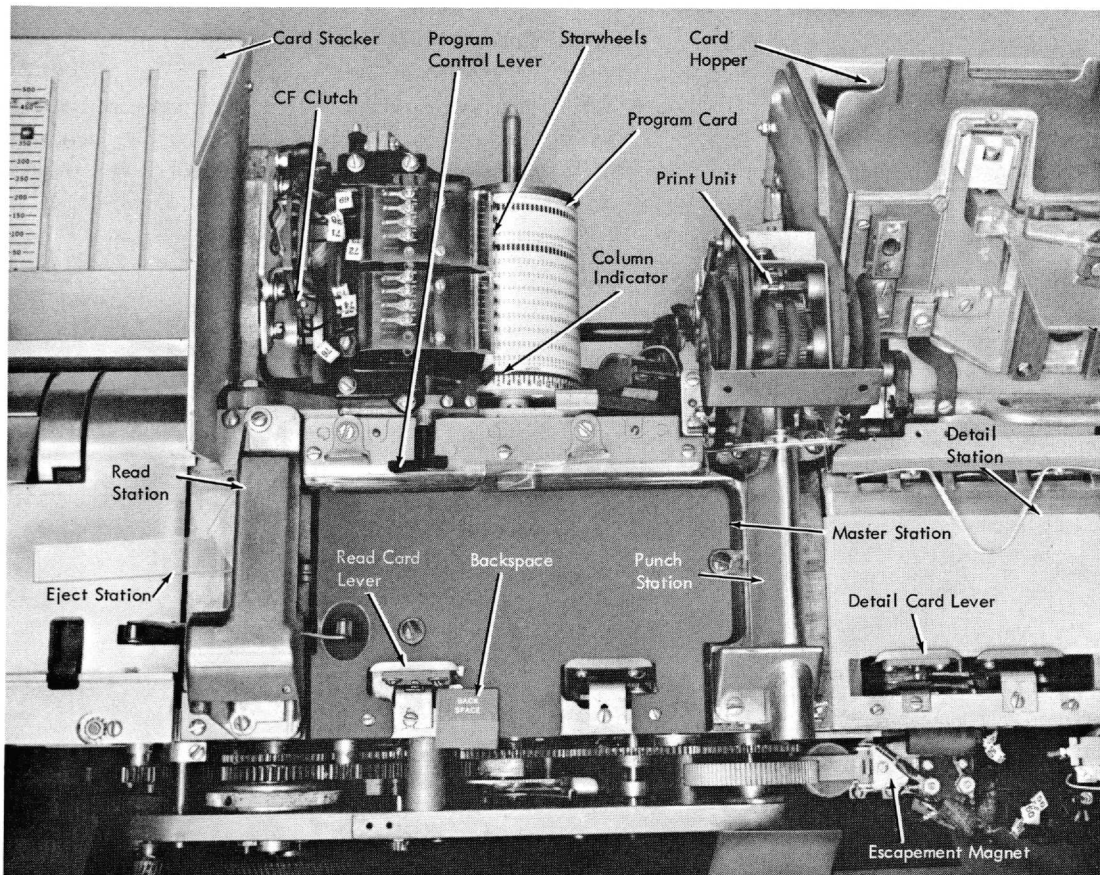

Figure 2-38. Program Unit

plate. The punch is pinned to the punch extension near the lower end of the punch extension and is free to travel up and down in the guide plate. The end of the punch operating arm rests in a notch at the guide plate end of the punch extension. The punch operating arm operates the punch extension and the punch. The punch operating arms operate in the guide comb, and the lower end of the punch extensions operate in the guide plate. When a card has been punched and the punch operating arm is restoring, the stripper pulls the card off the punch.

The punch operating arm motion used to drive the punch extension and the punch originates in the punch drive unit.

Program Sensing Mechanism

- Controls automatic machine functions through timed electrical impulses.
- Drops the escape armature into the correct tooth on the escape wheel with the correct overlap.

Distribution of electrical impulses by the program unit is mechanically controlled. Normal machine controls for automatic skipping, automatic duplicating, keyboard shifting, automatic left zero, and other functions are set up by punched codes in the program card. Electrical circuits in the program unit are completed by three different types of contacts:

1. Program handle switches 1 and 2.
2. Starwheel sensing contacts (eight on standard machines).

3. Program cam contacts 1 and 2.

All functions of the program unit are activated simultaneously by shifting the program control lever to the ON position (Figure 2-38). Separate function control is facilitated by the program select switch and program 1 and 2 keys on the keyboard.

The electrical impulses from reading (sensing) the holes in the program card initiate and control all automatic machine functions. The program drum and the master card register one column ahead of the detail card.

Program Shaft

- The program shaft rotates the program drum.
- The program shaft is driven by an idler gear in the escapement gear train and is pinned to the forked arm.

The program shaft gear is free on the shaft and drives the forked arm through a stud (Figure 2-39). The escape armature controls the static position of the escape wheel; the forked arm controls the position of the program shaft with respect to the escape wheel tooth overlap. The column indicator wheel is pinned to the program shaft. The program shaft moves in unison with master card and detail card movement.

Program Control Lever (Handle), Release Bail, and Drum Interlock

- The program control lever (also referred to as program control handle) activates the program unit. Shifting the program control lever to off position, operates the release bail (Figure 2-40).

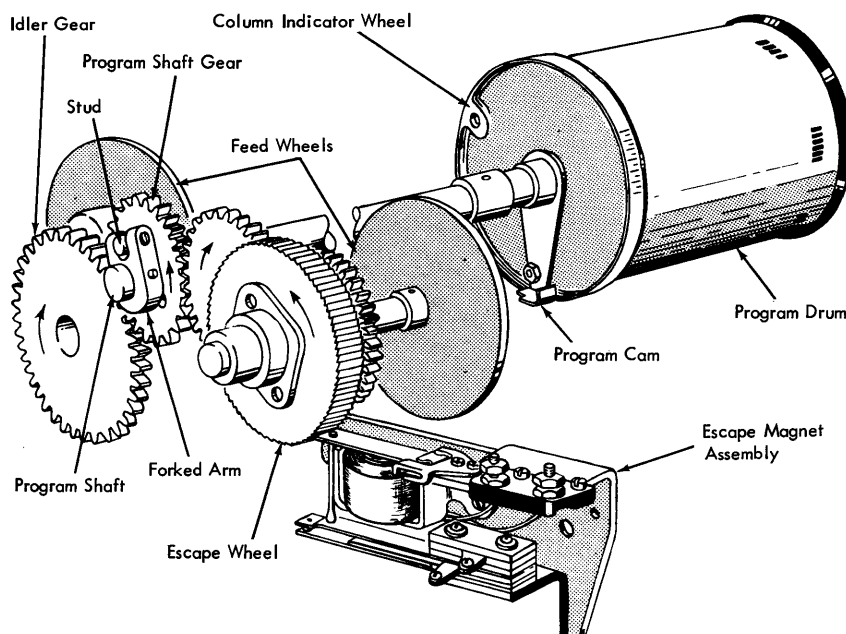

Figure 2-39. Program Shaft

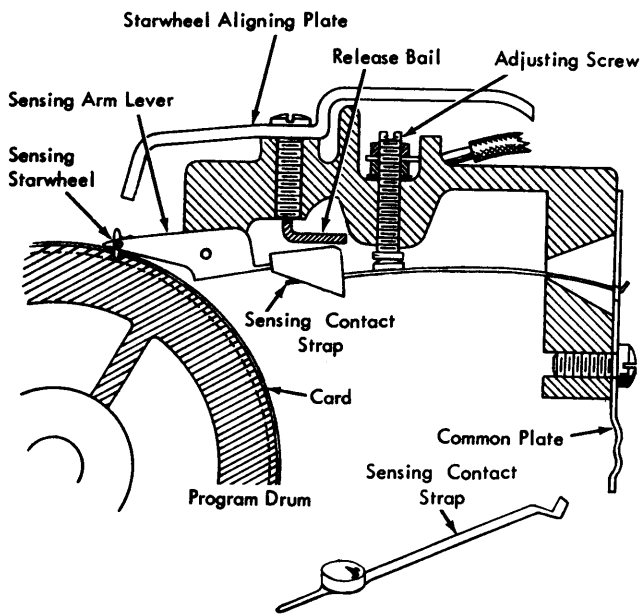

Figure 2-40. Starwheel (Program) Sensing Contact

- **The release bail positions the drum interlock so that the program drum can snap into position.**
- **The release bail raises the starwheels and arms off the program drum.**
- **The drum interlock transfers program handle switches 1 and 2 and prevents removing or replacing the program drum until the starwheels are raised.**

Starwheels and Starwheel Sensing

- **Controls circuits for automatic functions.**
- **The program drum card functions as a cam; the starwheel unit, the cam follower.**
- **The punched holes in the card represent the low dwell, which allows the starwheel sensing contacts to make.**

The starwheel rests on the program card when it has no punches. When the point of a starwheel is in the hole of a program card, the starwheel arm rests on the program card. Each starwheel arm operates a starwheel sensing contact (open when the points of the starwheel are resting on the program card). The top half of the program card contains program 1 operations, and the bottom half controls program 2 operations.

Figure 2-40 shows the starwheels (sensing wheels) that sense the punched holes in the program card to control the machine electrically. In general, the holes serve the same purpose as the low dwell on the normally closed circuit breaker cams.

The program control lever (handle) extends forward into the bed to activate or disengage the program control. Shifting the handle operates the release bail, which lifts or lowers all of the starwheels and which controls the drum interlock arm.

The starwheels must be raised high enough to clear the program drum when it is removed to change program cards. The drum interlock arm prevents the drum from being removed when the starwheels are engaged.

Starwheel Sensing Contacts

- **Drop the escapement armature into the correct tooth with the correct overlap.**

Each starwheel operates a starwheel sensing contact (referred to as starwheel contact, but also known as sensing contact and program sensing contact). A sensing contact is transferred (closes) as a point of its starwheel moves into a hole in the program card.

The stationary contact air gaps of the starwheel contacts are adjustable. The gap determines the duration of the impulse, and the forked arm adjustment (on the program shaft) determines the timing. The sensing contacts are of the strap type that uses a common contact bar. The sensing contact straps are operated by the starwheel arms. These contacts provide a +48 volt circuit path for controlling programmed functions. Their most important function is to drop the escapement armature into the correct tooth with the correct overlap.

The starwheels slide along the blank portion of the program card on two of their five points (Figure 2-41). As a hole is encountered, the leading point rolls into the hole. The sensing contact that is controlled by the starwheel closes. When the starwheel seats in the hole, the sensing arm that carries the wheel rides the program card. Consecutive holes (for example, 12's) in the program card allow the contact to remain closed. Thus the field definition (12) contact serves as a hold circuit breaker. An automatic skip or duplication can be initiated, and continues to the end of the field because the 12-sensing contact stays made as long as there are 12-holes in the program card.

Program Handle Switches 1 and 2

- **Program handle switches 1 and 2 are microswitches with enclosed contacts.**
- **These switches are transferred by the drum interlock arm whenever the program lever is shifted.**

All functions of the program unit are activated simultaneously by shifting the program control lever to the ON position (starwheels down).

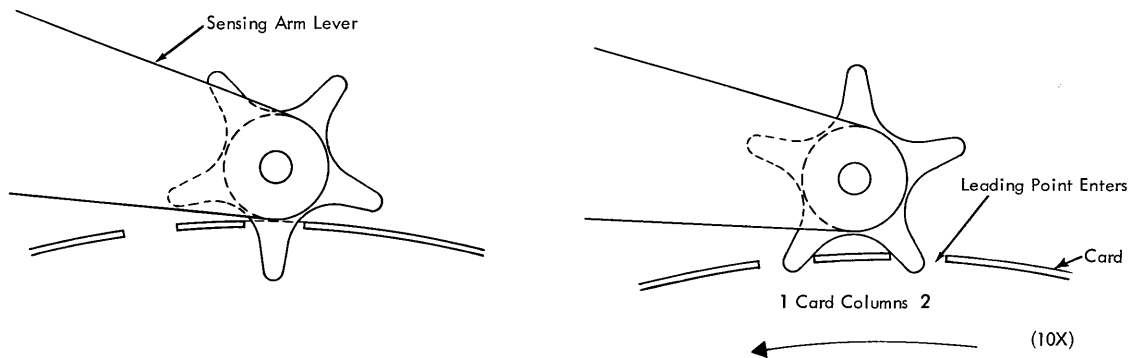

Figure 2-41. Starwheel

With the starwheels raised:

1. Program handle switch 2 places the machine in alpha mode (shift) and removes the +48 volts from the starwheel contacts.

2. Program handle switch 1 transfers control of the escape magnet from a release operation to a combination release skip controlled function for the entire card.

With the starwheels down:

1. Program handle switch 1 places the machine in numeric mode (shift) and transfers release control circuits of the escape magnet to allow the starwheels to control the release.

2. Program handle switch 2 provides +48 volts to the starwheel contacts.

Program Cam Contacts

- The program cam contacts control automatic skipping from column 80 to column 1 of the program drum, and automatic feeding of the next card.
- The two contacts are in back of the column indicator wheel and attached to the machine casting.
- A program cam fastened to the column indicator operates the contacts.
- The contacts are PCC1 and PCC2.

When the program drum completes one revolution, the program cam contacts (Figure 2-42) complete one cycle of operation. The program cam contacts are adjustable for duration, and the program cam is adjustable for timing.

The program cam has a sharp rise and an instant fall. The cam operates PCC1 and PCC2 during the drum skip from column 80 to column 1 on the program drum. The program cam contacts provide a circuit for automatic feeding during a drum skip, and ensure that the program drum stops in column 1 at the end of the skip.

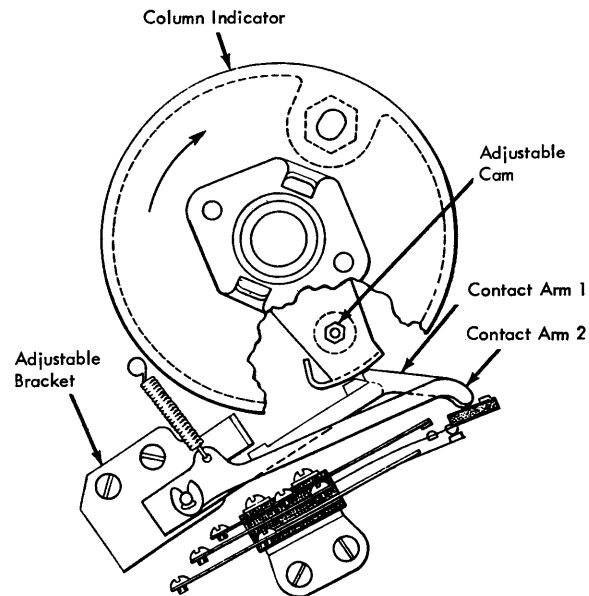

Figure 2-42. Program Cam Contacts

Pin Sensing Unit Mechanics

- The pin sensing unit is the card reading section of the read station.
- All digits in a card column are simultaneously tested by the pin sensing unit.

A card at the read station is placed in registration at the column-1 end. Because the detail card is registered from the column-80 end and then punched, any variation in registration of the holes appears at column-1 end. Dual sensing pins help compensate for any discrepancy that might occur in the length of cards or in registration. There is a separate contact for each pin to ensure that a hole is read when either pin operates.

The pin sensing unit is spring operated under control of the sensing pin bail cam in the punch unit. One complete cycle of operation of the punch drive unit

executes one cycle of operation of the pin sensing unit. When a card is registered at the read station, the pin bail is allowed to operate by the master card lever with a force equal to the tension of the drive link spring.

The sensing pin bail cam on the punch drive shaft operates the pin sensing unit (Figure 2-43) by transferring motion through the bail drive link, the short bail link, the pin bail arm, and the pin bail.

With a card at the read station, the pin bail allows the dual sensing contacts to lift the sensing pins and apply pressure on the card. If there is a hole in the card, the pins will extend through it and the contacts will make on the common contact strip. This completes the circuit for the interposer magnets. The other digits (blanks) will not allow the pins to extend upward far enough for the contacts to make on the common contact (see Figures 2-44 and 2-45).

With no card at the read station and one in the punch station, the pins are made inoperative by the action of the master card lever. The card lever is spring loaded, so that a no card condition lets the tip of the card lever rest on the pin bail and prevents the bail link from following the sensing pin bail cam.

The sensing pins are spring operated by the contact straps, and restored by the pin bail.

Pin Bail and Pin Bail Arm

- The pin bail and arm are pinned to same shaft.
- The pin bail arm operates the pin bail.
- The arm is operated by the short bail link connected to the bail drive link by the adjusting screws.
- The pin bail retracts (restores) the sensing pins.

The pin bail (Figure 2-43) is raised by the sensing pin bail cam on the punch shaft. This permits the sensing pins to seek the punched holes in the master card. The pin bail is held inoperative by the tail of the card lever when the card lever's upper point extends through the card line. The pin bail is fully restored when the pin bail arm is against the eccentric stop and the punch drive unit is at 345°. The bail link adjusting screws and the eccentric stop determine the restored position of the pin bail.

Master Card Lever

- This lever prevents pin sensing of all 12 positions when no card is at the read station.
- The lever allows the pin bail to operate when a card is registered.

A card registered at the read station holds the card lever flush with the card line and allows the pin bail to operate under control of the sensing pin bail cam. The sensing pin bail cam follower cannot follow the cam when the pin bail is held by the tail of the master card lever.

The pin bail drive link spring makes the drive link follow its operating cam. To pin sense with no card at the read station would mean that all the pins would rise and close their contacts. To prevent this, a spring operated master card lever (Figure 2-43) blocks the rise of the pin bail by preventing the drive link cam follower from riding into the low dwell of the pin sensing cam. This eliminates pin sensing of all 12 positions while cards are at the punch station only, and while the punch clutch magnet is energized. With the punch clutch latched up at 345°, the pin bail lowers, the pins retract below their separator guide, and the card lever is free to operate.

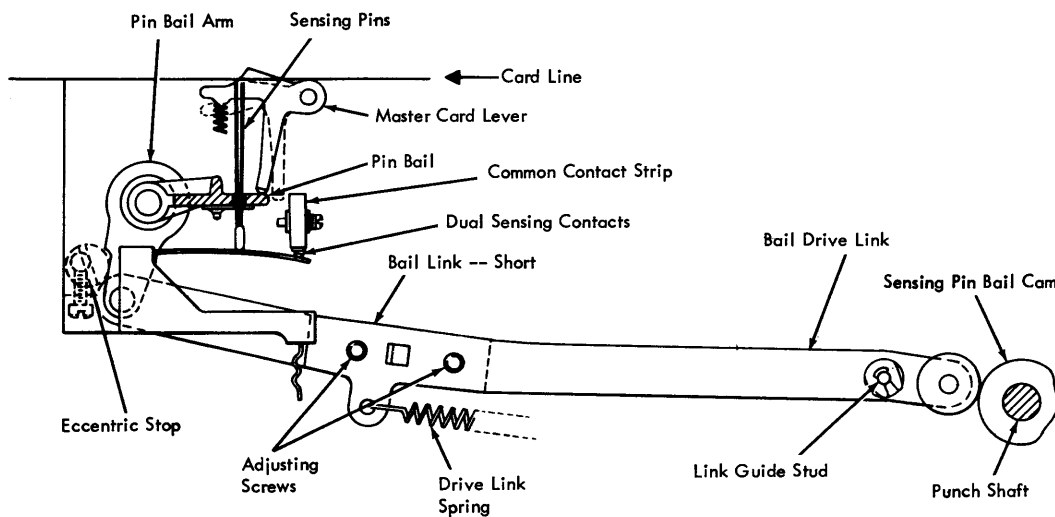

Figure 2-43. Sensing Pin Bail

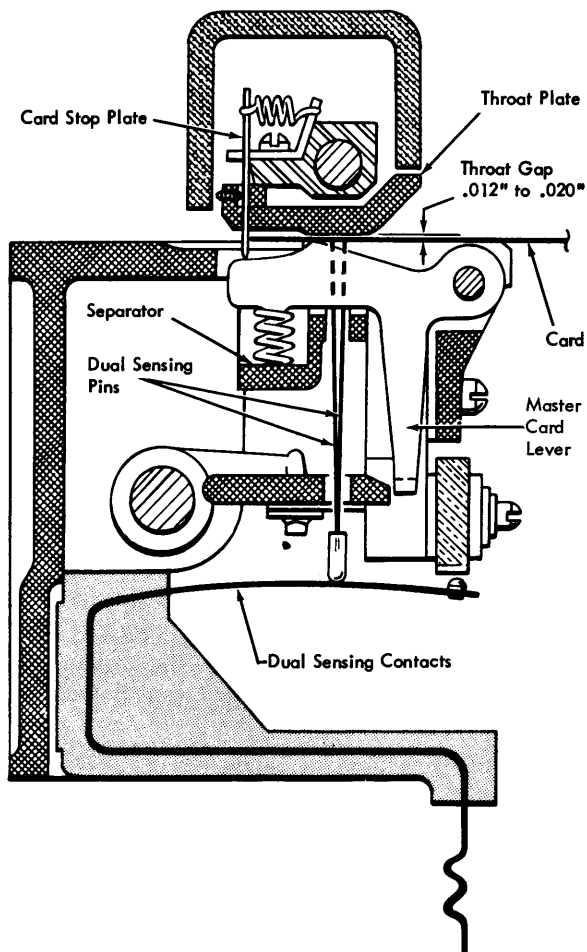

Figure 2-44. Sensing Pin Mechanism

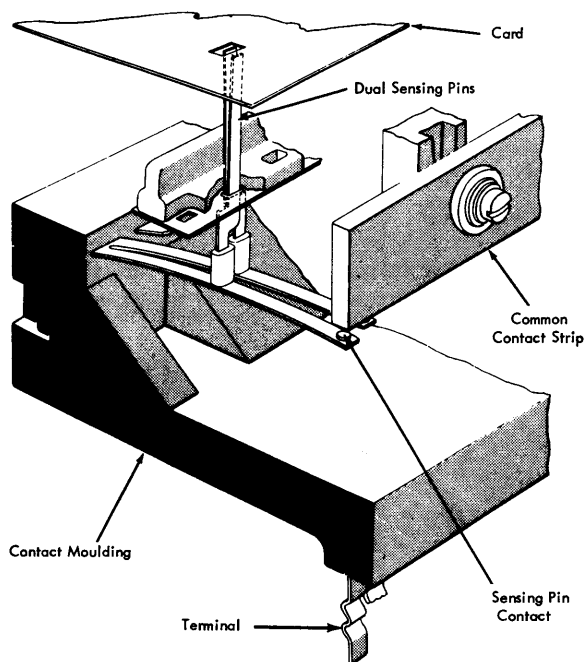

Figure 2-45. Sensing Pin Mechanism

The removable pin sensing unit, although operated through linkage from the punch shaft, is not essentially a part of the punch drive unit assembly.

Refer to the mechanical timing chart (Figure 2-14) for comparison of punch travel and pin contact duration. Both the sensing pins and the punches are free of the card by 180° when P1 makes to allow escape-ment. Although both the punches and the sensing pins are positively restored, a binding or sticky punch can cause the card to jam.

Sensing Pin Separator

- The separator guides the sensing pins when they are operated.

The separator (Figure 2-44) is a portion of the pin sensing unit frame and is made of insulating material. The pin sensing unit is mounted in the machine so that the separator is flush with the card line.

Sensing Pins and Contacts

- 12 sets of dual sensing pins (Figure 2-45) read (sense) the card at the read station.
- There is a sensing pin contact for each sensing pin (24 contacts).

The dual sensing pins operate independently; the seating of either one of the dual contacts on the common contact strip completes an electrical circuit to the interposer magnets. The sensing pins are raised by the spring tension of their contacts and are retracted by a cam driven bail. A set of pins spans 0.043", or half the lateral distance between the leading edge of a hole in one column to the leading edge of a hole in the next column. The space between pins is too small to permit reading of two columns at once when the card is registered properly.

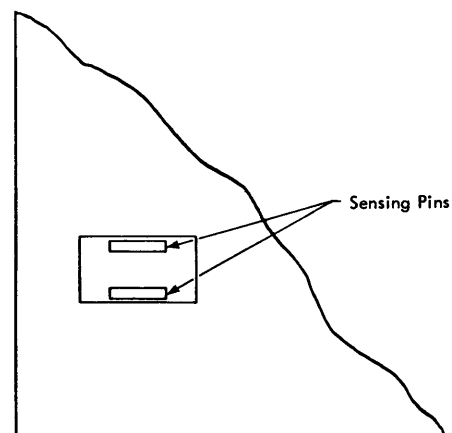

Figure 2-46. Correct Sensing Pin Card Registration (Read Station)

During a sensing cycle, if both of the pins extend through a hole in the card, it is an *ideal* pin sensing condition (Figure 2-46). Off registration is the cause for only one of the pins extending through a hole in the card at the read station (Figure 2-47). Completing the electrical circuit when there is no hole in the card is a malfunction, and causes erroneous energizing of an interposer magnet. Failing to complete the electrical circuit when there is a hole in the card is also a malfunction.

Reed Relay

- Reed relays demonstrate:
 - High-speed
 - Reliability
 - Sensitivity
 - Low Cost.

The dry reed switch is versatile. Some of its applications are in: electromechanical transducers, power amplifiers, relays, switches, and logic circuits.

A dry reed switch (Figure 2-48) consists of two magnetic reeds of nickel-iron alloy supported by and enclosed in a glass tube. The reeds have a diffused gold-rhodium surface to provide low contact resistance, high reliability, and long life. The tube, containing an inert gas, is hermetically sealed to protect the reeds from dirt, humidity, corrosive fumes, and variations in barometric pressure.

Normally Closed Reed Switch: Normally closed reeds are made in pairs using a small permanent magnet between the switches to bias them closed. The operate magnetomotive force of normally closed reeds is approximately 27 to 38 ampere-turns. Three components are molded together in a single module and pre-adjusted to assure:

1. Matched characteristics of the two reeds.
2. Specification limits are not exceeded.

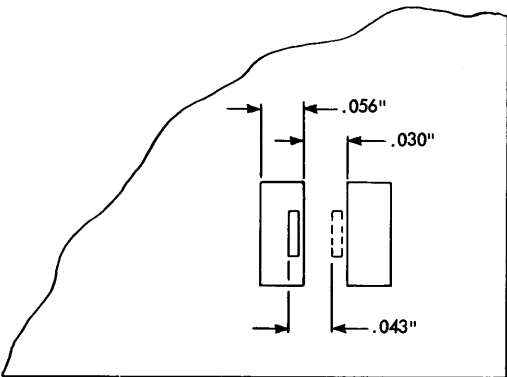

Figure 2-47. Incorrect Sensing Pin Card Registration (Read Station)

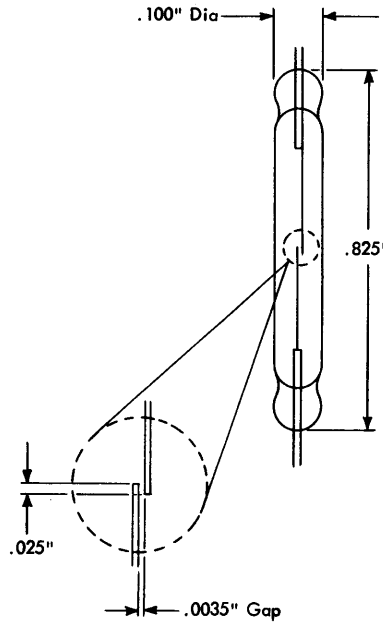

Figure 2-48. Reed Switch

3. Repeatable characteristics for life of the module.
4. Easy replacement.

The modules are convenient to stock and handle and require only those precautions that would normally be observed with the reed switch and permanent magnet.

Reed Switching Methods: The contacts of a reed switch can be brought together by an external magnetic field that exceeds the switch's pull in force. This field can be produced by either a permanent magnet or an electromagnet.

Reed Switching with Electromagnetic Action: The most frequent use of the reed switch is with an electromagnet. Single and multiple single-throw devices can give either normally open or normally closed operation. Transfer operations can be accomplished by combinations of the two basic devices.

Reed Relay Terminology

Reed Normally Closed Contacts (N/C): When a permanent biasing magnet, without coil energization, causes the reeds to remain in contact, they are normally closed.

Reed Normally Open Contact (N/O): The position of the reeds in the absence of any permanently magnetic field is normally open.

Reed Operate Time (Pick Up): With a normally open relay, operate time is the time required for the reeds to make contact (bounce free) after a dc voltage is applied across the operating coil. With normally closed contacts, it is the time required for the reeds to break contact after the coil is energized. Maximum operate time in either condition is 1 millisecond.

Reed Release Time (Drop Out): Release time is the time required for normally open contacts to separate and for normally closed contacts to close (bounce free) after the voltage is removed from the operate coil. Each N/O contact will release within 0.5 milliseconds with no coil suppression, and each N/C contact must reclose within 1ms with no coil suppression.

Reed Contact Bounce (N/O): Contact bounce is any open circuit occurring during operate time after the initial contact of the reeds. During release time, it is any contact of the reeds after they have first opened.

Reed Contact Bounce (N/C): Here, contact bounce is any contact of the reeds after they have first separated during operate time. During release time, it is any separation of the contacts after the first time they have closed.

Reed Relay Package

- This package is pluggable to provide for quick removal and insertion of the relay assembly to the circuit card.
- A locating pin molded in the bobbin assures proper attachment of the relay to the printed circuit card.

Figure 2-49 is an exploded view of a reed relay with four contacts. The reed relays have 48 volt pick and hold coils, but the IBM 29 uses only the pick coil. Reed relay contact combinations are:

1 contact	N/O
2 contacts	2N/O or 2N/C
4 contacts	4N/O, 4N/C, or 2N/O and 2 N/C
6 contacts	6N/O, 6N/C, or 4N/O and 2N/C, or 4/NC and 2N/O.

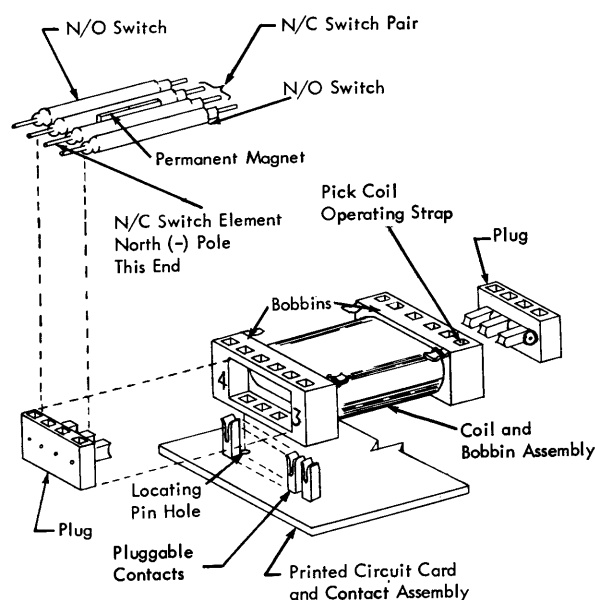

Figure 2-49. Reed Relay Package

Reed relays containing N/C points are polarized by the permanent magnet used for biasing. When the relay is energized, the N/O switches close, and the force of the permanent magnet is overcome to allow the N/C switches to open. Proper polarity opposes the bias magnet in order to open the N/C points. Maximum current in steady state through the reed switch is rated at 1 ampere.

The reed switch elements connect the reed switch to the circuit card. The reed relay coil is connected to the card in a similar manner. The reed switches are cemented at either end of the plugs within the coil and bobbin assembly. A locating pin on the 4 bobbin end position is used to locate the reed relay on the circuit card and distinguish the top of the relay from the bottom.

Reed Relay Identification

- The relay is mounted on the card so that the pick coil is at the top and the operating (+) straps are on the left side.
- The numbers 1 and 2 are etched on one bobbin of the relay and the numbers 3 and 4 are etched on the other bobbin (Figure 2-49).

The relay is mounted on the card so that the 1-2 bobbin is on the left and the 3-4 bobbin is on the right. The pick coil is wired between 1 and 3. Connections 1 and 2 are wired to the positive side of the circuit; 3 and 4 to the negative. The points of the relay are numbered from top to bottom between the pick and hold coils (Figure 2-50C).

Circuit Card

- The circuit card is used to mount relays and other circuit components.
- All external wiring to the card is cabled directly to six edge connector tabs.
- The card can be moved into a service position, and serviced, without being disconnected.

The card is 9" high and 20" wide (Figure 2-50A). Card references are made with the front of the card facing the viewer and the connector tabs pointing up. The front side of the card is the component mounting side. Component designations are from left to right, top to bottom.

The six connector tabs are labeled A-F, from left to right. There are 30 connections on each tab: 15 connections on the front and 15 connections on the back. The front connections are labeled 1, 3, 5-29 (odd numbers.) The back connections are labeled 2, 4, 6-30 (even numbers). (Example: 1C07 is card 1, connector tab C, connection 07).

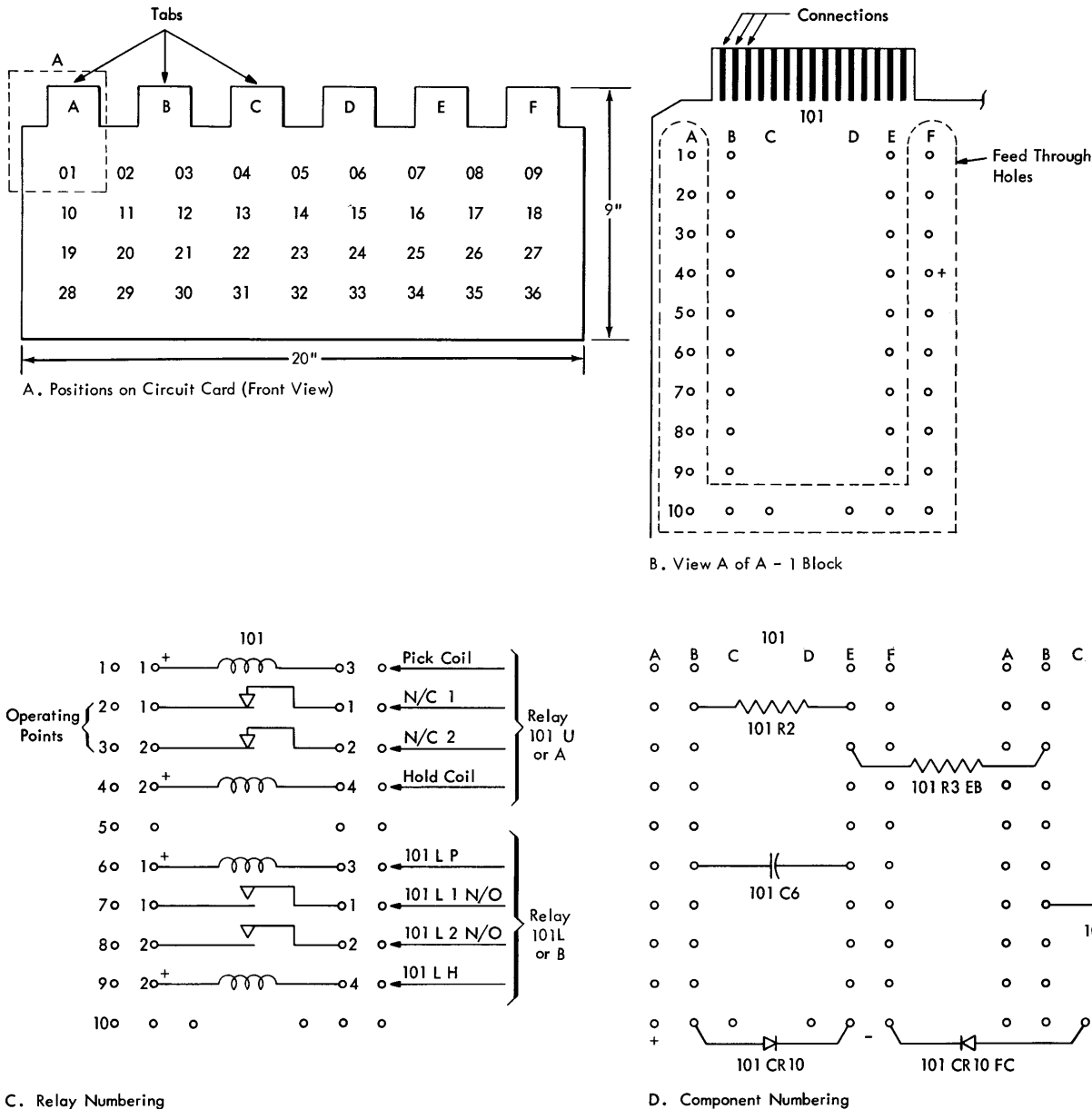

Figure 2-50. Circuit Card Component Location

The block (position) is the main component location factor. Blocks are labeled (left to right, top to bottom) with block 01 in the upper left-hand corner, and block 36 in the lower right-hand corner (Figure 2-50A). The full designation of a block is 101, 102, etc. The high-order digit represents the card number. When a machine has more than one card (example: left-zero feature), the second card is card 2, and block 01 becomes 201, and so on.

Each block consists of two columns of nine holes defining the left edge and right edge of the blocks. The bottom edge of the block is defined by two groups

of three holes each. Each column is designated by a letter (A-F) (Figure 2-50B) and the rows are numbered sequentially from top to bottom. The hole designation remains the same for each block on the card. This enables each circuit card hole to be identified by card number, block number, column letter, and row number. In Figure 2-50B, to indicate the location, we have marked a + beside hole 101F4 (the + is not on the actual circuit card).

Relays are mounted on pluggable contacts that are molded into the board. When there is more than one relay in a block, the relays are designated: U or A

(upper), and L or B (lower). The U is the top relay, the one closest to the connector tabs. *Example:* 101U and 101L as shown in Figure 2-50C.

Components on a card can be connected between the two columns within a block, or between two adjacent blocks. A component connected within a block is designated by block (number), component (symbol), and row (number). *Example:* 101CR10 (Figure 2-50D) is a diode (CR), connected within block 101, in row 10. A component connected between blocks is designated by the from-block (number), component (symbol), row (number), from pin (letter), and to pin (letter). *Example:* 101CR10FC is a diode (CR), connected from block 101 in row 10, between pin F (of block 101), and pin C (of block 102). Also in Figure 2-50D: 101R3EB is a resistor (R), connected from block 101 in row 3, between pin E (of block 101), and pin B (of block 102).

Edge (SMS Card) Connectors

- Edge connectors provide pluggability between major units of the machine.

The basic machine with print mechanism uses six SMS-type edge connectors. The keyboard, circuit card, and base units (for field installation of print mechanism) use edge connectors.

Each connector has 30 contacts that mate with either the circuit card tabs or a paddle card. Connectors A-E mount on the tabs of the circuit card and are used to distribute machine circuits to and from the relays. Connector Z mounts to a paddle card that is attached to the machine frame to the rear (back) side of the circuit card. The connector chart on Systems 01.29.18.0 of the wiring diagram identifies the connector pin locations in the wiring diagram.

Standard Modular System (SMS)

Standard printed wiring cards are used in the modular type of packaging. These SMS printed wiring cards facilitate the manufacturing process and permit standardization of circuits. The pluggable printed circuit cards contain all the components and printed wiring necessary for a particular electronic function or functions. Other printed wiring cards are used as cable connectors and back panel voltage distribution buses.

Description

The SMS *single card* (Figure 2-51) is made of an epoxy paper laminate material and is 0.056" thick, 4½" long, and 2½" wide. All of the electronic components

are mounted on the front side of the standard SMS card form. Connections to the components are made on the back side of the SMS card form by printed wiring patterns that terminate at contacts at the bottom of the card. These contacts, labeled A-R, couple the signal and standard service voltages to the circuit components when the card is inserted in the SMS socket. The printed circuit wiring (land pattern) depends on the circuit configuration of the card.

SMS twin cards (Figure 2-51) are made of the same material used in single cards. Twin cards are 5¼" wide; other dimensions are the same as for single cards. With twin cards, more circuitry can be packaged in a given space than with single cards.

The dual-density twin card (Figure 2-51) has electronic components mounted on the front side of the card. This card contains as many as 14 reed relays. Connections to components are on both sides of the card and are made by printed wiring patterns that terminate at 32 possible contacts on the back side of the card. These contacts, A-Z and 1-8, couple the

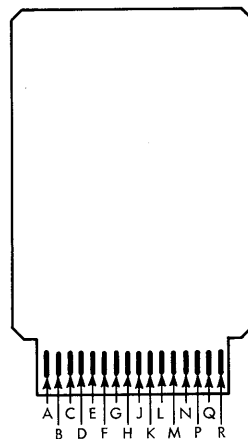

A. Single Card

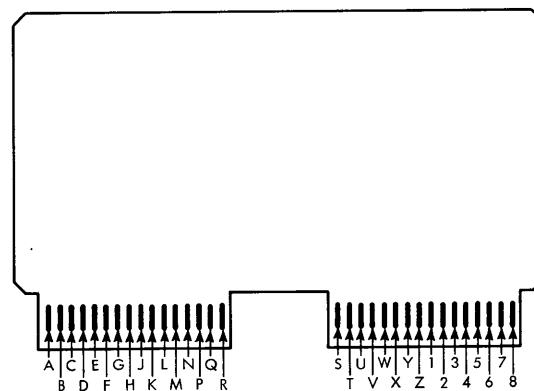

B. Twin Card

Figure 2-51. SMS Printed Wiring Cards

signal and service voltages to the circuit components when the card is inserted into two vertically adjacent SMS card sockets (Figure 2-52).

SMS Card Receptacles

The pluggable printed circuit cards are inserted into SMS receptacles as shown in Figure 2-52. Although the contacts are all in line on the card insertion side of the SMS receptacle, they pass through the receptacle in a staggered arrangement as noted in the figure. This staggering allows additional room for wire-wrapping or soldering of signal and voltage wires to the terminal pins.

SMS Locations and Pin Numbering

SMS locations are identified by:

1. Row,

2. Column or card number,
3. Pin.

Refer to Figure 2-52.

Wire Contact Relays

The wire contact relay is pluggable, employing a terminal molding connector that permits completion of wiring before the relay is installed in the machine. For detailed information on wire contact relays, refer to IBM Field Engineering Maintenance Manual, *Motors, Generators, Circuits*, Form 225-3422.

Reed Relay Machines

One four-position, high-speed, wire contact relay is used in the escape and punch clutch circuitry. A normally closed point breaks the escape magnet circuit; a normally open point picks the punch clutch magnet. This relay is located in back of the stacker, and is removable for inspection or replacement.

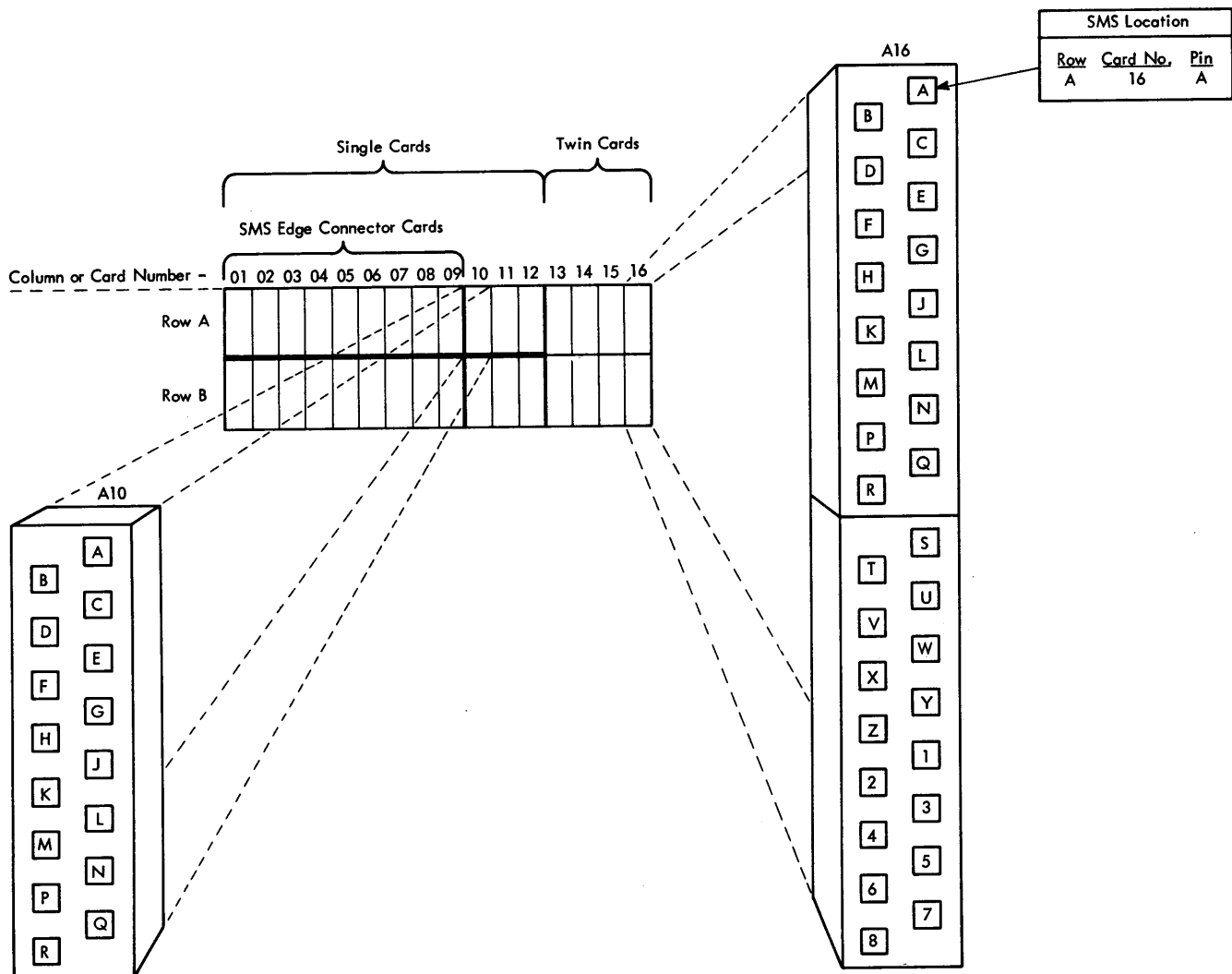

Figure 2-52. Wire Contact Relay Machine Relay Gate (Card Side View)

A second four-position wire contact relay is used as the ALPHA relay. A normally open point selects the alphabetic bails and latches; a normally closed point selects the numeric circuitry. This relay is located in the keyboard behind the latch assembly. The keyboard top cover must be removed for access to the ALPHA relay.

Wire contact relays are used in these circuits instead of reed relays because the wire contact relays can more capably handle the high incident 48vdc surges. The silver alloy contacts of the wire contact relay can stand more arcing than the reed switches.

Printing Mechanics

- The print unit contains 35 flexible, stainless-steel wires capable of printing a series of closely spaced dots in the shape of a character.
- Printing is done one character at a time.
- The printed character appears near the top edge of the card in the same column as it is punching.
- 62 different characters can be printed on machines having the EL (Expanded L) code plate.

Figure 2-53 is a front view of the print unit, and Figure 2-54 is a rear view. The wire guide (shown with respect to the die and stripper) extends through the die and is flush with the bottom of the die. The portion of the stripper directly below the small end of the wire guide is the platen for the print unit. The wire guide provides individual passages or tubes for the 35 print wires. At the small end of the wire guide, the 35 print wires converge in a rectangular form that is the over-all size of a letter (Figure 2-55).

A card at the punch station is between the die and stripper. With the wire guide in place and a ribbon over the end of the wire guide, any print wire pressed will leave its imprint (in the form of a dot) on the detail card. Through proper selection of a combination of the 35 print wires, any character can be printed. Printing and punching a character occur on the same punch cycle. The printed character will appear at the top of the same column in which it is punched.

A character to be printed must also be punched. A character to be punched does not have to be printed. A print switch on the keyboard turns printing on or off, but has no effect on punching.

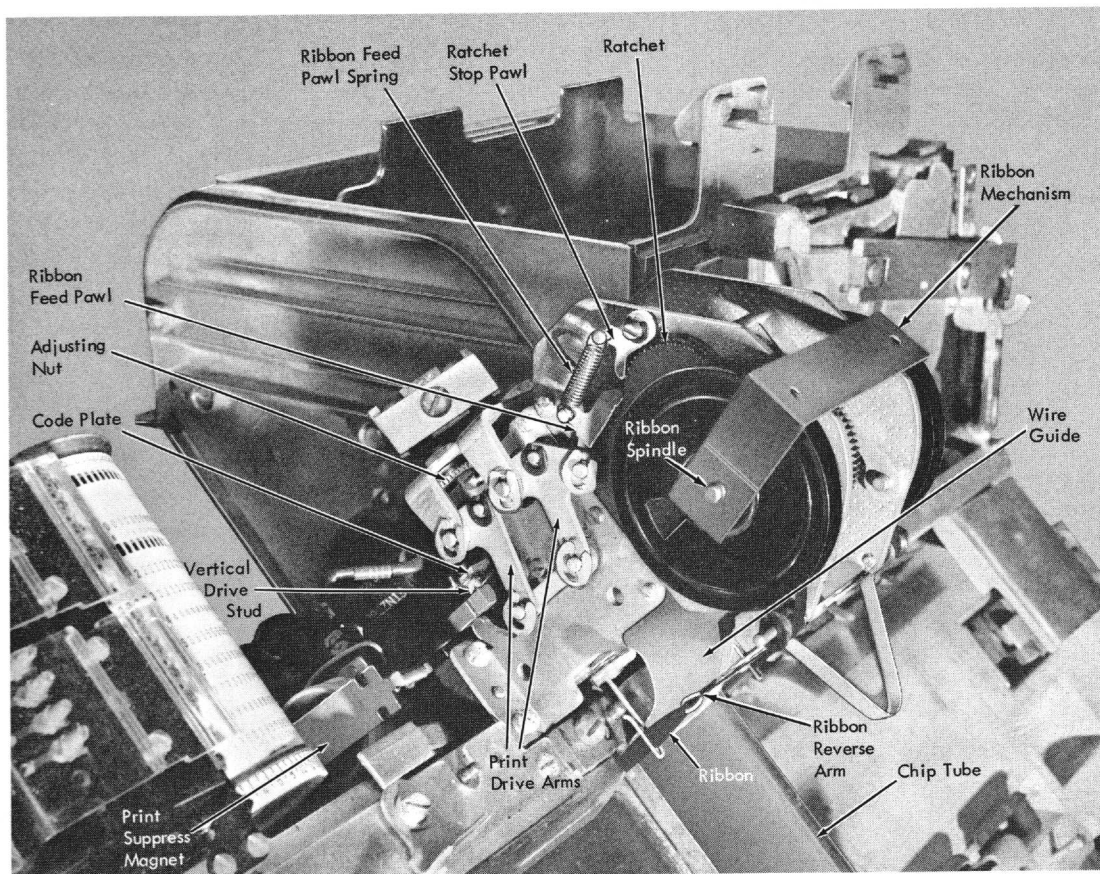

Figure 2-53. Print Unit (Left Front View)

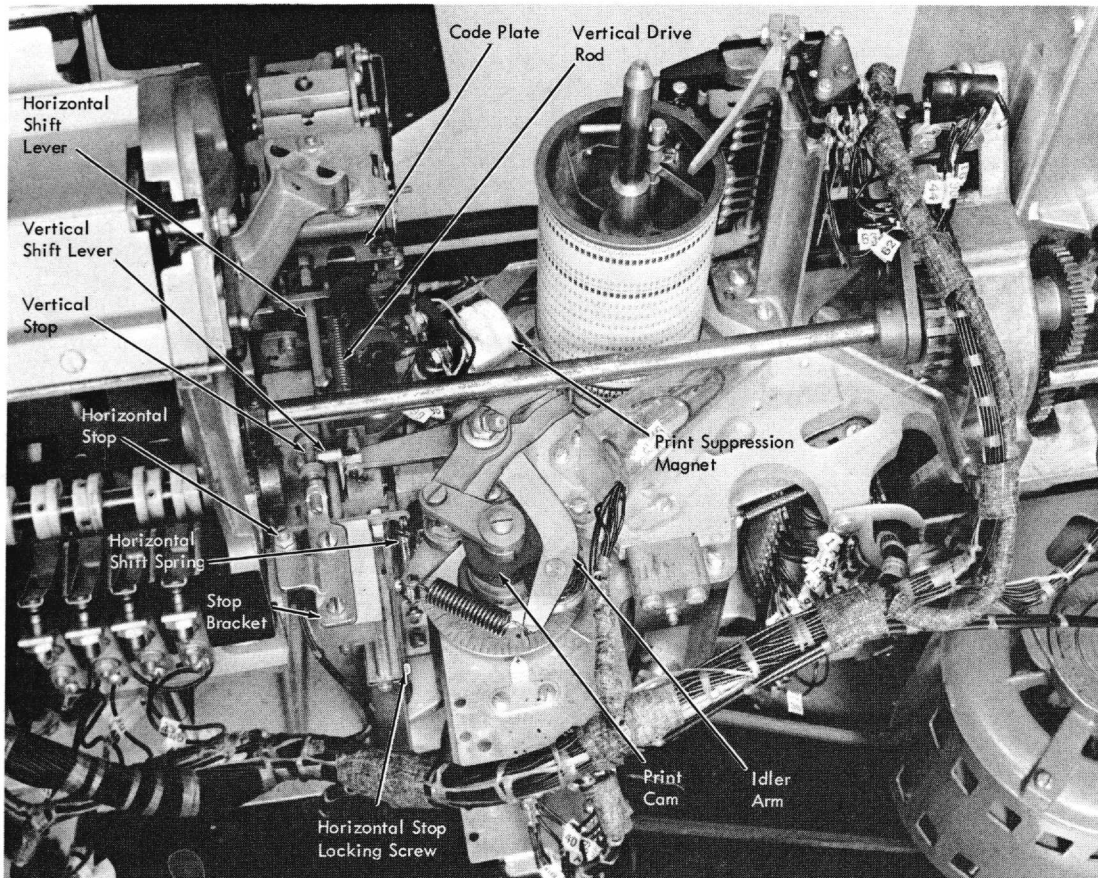

Figure 2-54. Print Unit (Rear View)

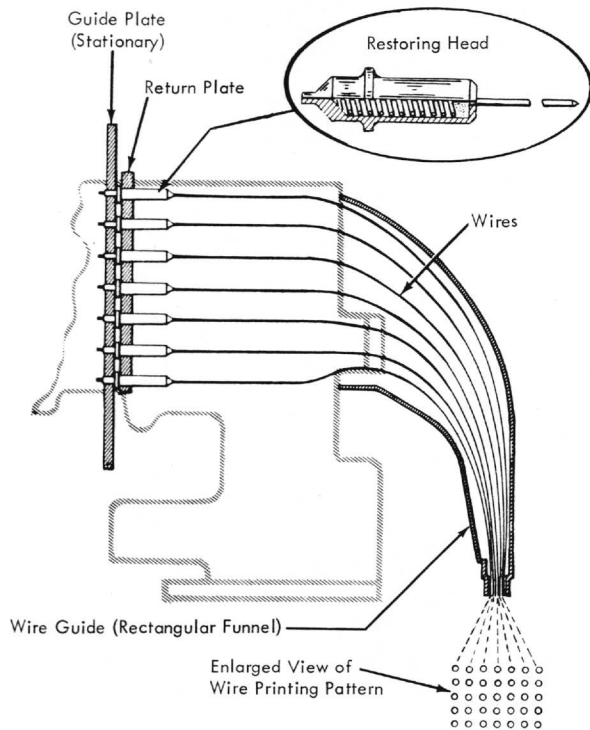

Figure 2-55. Print Wires

A code plate, with projections that outline all characters associated with the symbols on the keyboard, is used. When the code plate is forced against the wires, only those wires struck by the projections leave impressions (dots) to form a character.

The code plate projections are arranged so that by moving the code plate vertically, horizontally, or both, the same code plate serves for all characters. A system of punch operated interposers that functions in measured units according to the letter code or character punched, positions the code plate (through linkage) to the desired area.

By combining the punching of the card and the shifting of the code plate, all motion is controlled and operated through the revolution of the punch shaft. The rotating motion of the punch shaft is converted to reciprocating motion by the print drive unit and is transferred to the pressure plate by the print drive rod (see Figures 2-54 and 2-56).

A mechanical print cam, located on the punch shaft outside of the punch index, operates the linkage (through the print drive rod) to force the code plate against the wires and to print. Thus, the punch shaft operates the punches and the print plate. As the card

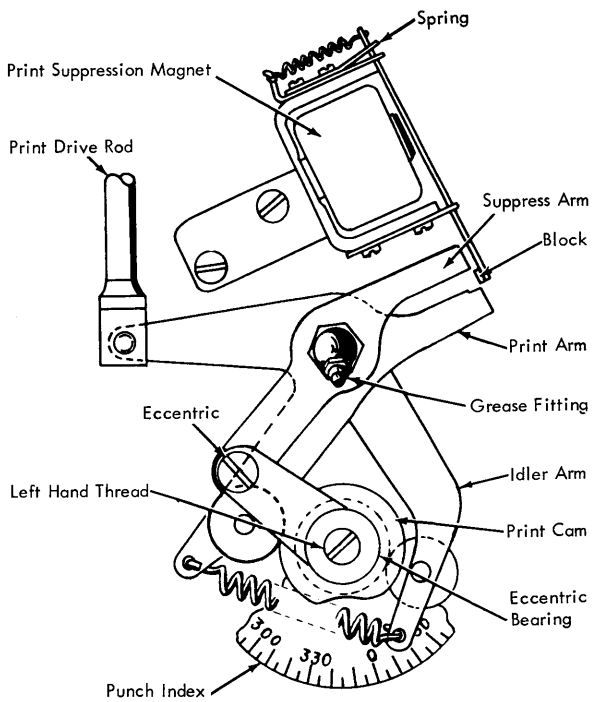

Figure 2-56. Print Drive Unit

is punched, the punches (through linkage) shift the code plate, so that the corresponding character also prints.

Print Wire Restoring Heads

- **Printing takes place when a code plate projection makes contact with a print wire restoring head.**

Each print wire (see Figure 2-55) has a restoring head fastened near the end that the code plate operates. A compression spring, located in the restoring head, controls the printing pressure of the wire against the ribbon so that uniform density of a printed character is produced.

A print wire restoring head can be seen in Figure 2-55. For a wire to be pressed, a projection on the code plate must rest on the tip (left end in the illustration) of the restoring head so that when the code plate is forced down, any print wire having its restoring head tip lined up with a code plate projection will also be forced down.

Code Plate

- **The code plate is shifted by the print interposers (through linkage) to select the correct combination of print wires to print a character.**
- **Code plate shifting is measured in relation to the amount of travel away from its home position.**

The code plate is approximately $\frac{7}{8}$ " wide and $1\frac{1}{4}$ " high and contains a great many small projections (Figure 2-57). The top surface of each projection is 0.015 " square. Center to center, adjacent projections measure 0.022 ".

The code plate is divided into 35 (7 x 5) sections. Each section is divided into 64 (8 x 8) projection locations (Figure 2-58). These 64 projection locations are defined as locations, because no one section actually contains the maximum 64 projections. It would be possible to have 2,240 (40 x 56) projections, but projections exist in only the usable positions.

In Figure 2-58, the 35 circles define the location of each restoring head tip when the code plate is in its normal or home position. These home positions are milled-out holes 0.025 " in diameter and a depth of 0.010 " below the surface of the code plate. Because the restoring heads are adjacent to these blank positions when the code plate is in its home position, nothing prints during spacing or during the pin sensing punch shaft revolution to start automatic duplication.

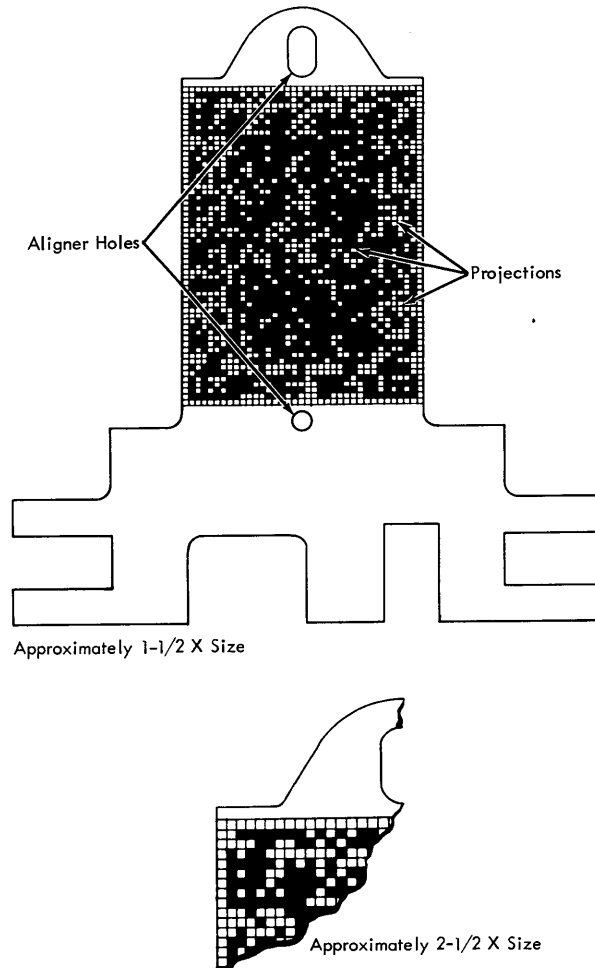

Figure 2-57. Code Plate

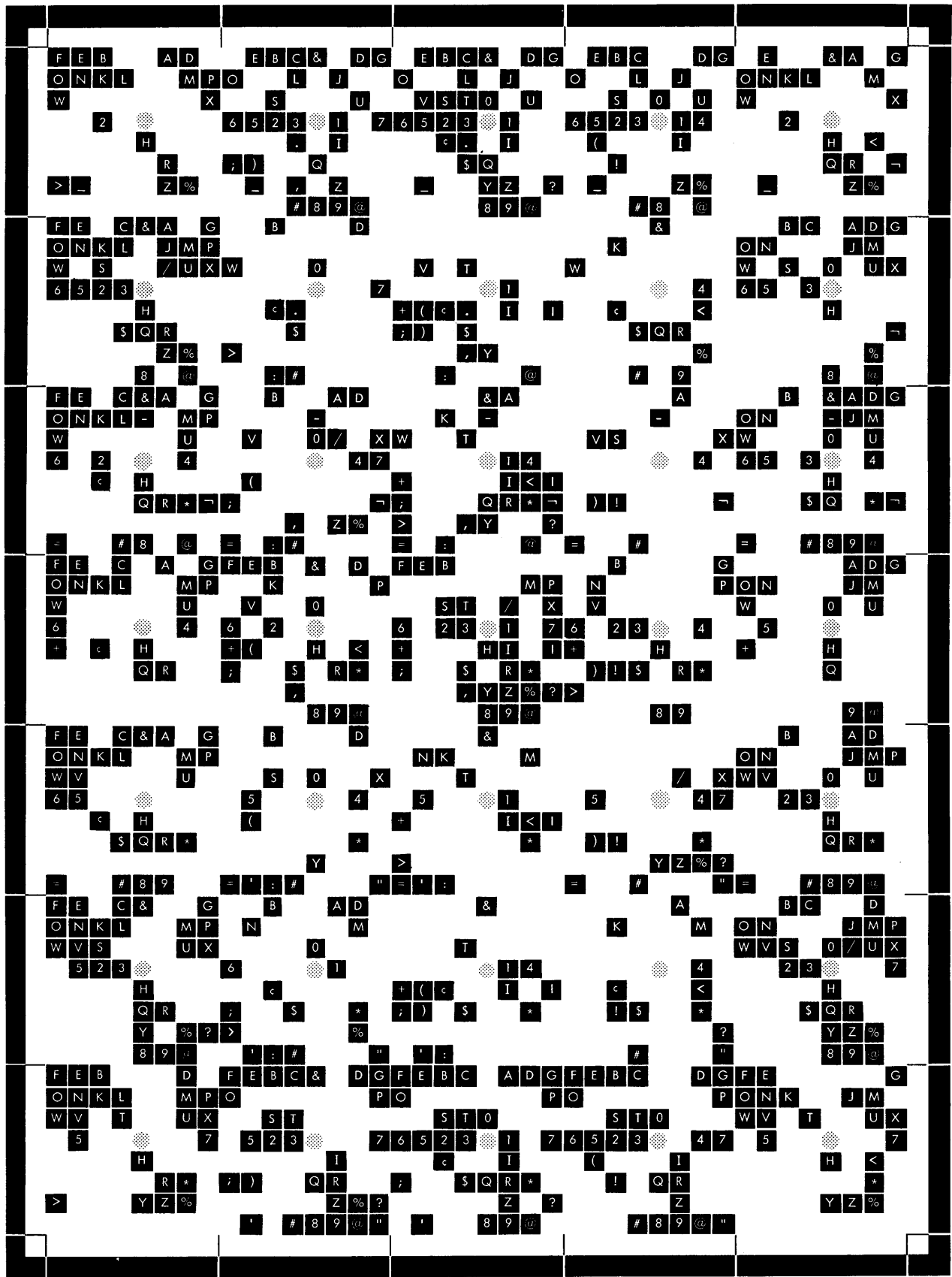

Figure 2-58. Code Plate Chart (Expanded "L")

The print wires are spread 0.176" horizontally and 0.176" vertically in front of the code plate. Each print wire restoring head faces one of the 64 (8 x 8) rectangular projection areas. Figure 2-58 shows that when positioning the code plate with respect to the tips of the restoring heads, sufficient code plate projections can be aligned with restoring head tips to print any character. At a given time, only some of the restoring heads are aligned to positions that have projections. Moving the code plate up or down, right or left, or any combination of movements changes the wire combination and also changes the printed character.

During a punch cycle, the print interposers move the code plate (through linkage) in units of 0.022", which is the center-to-center position of adjacent projections. A code plate shifted three units is equal to 0.066" travel from its home position. Upward shifting of the code plate is a positive shift, and downward shifting is a negative shift. Moving the code plate down three units is a negative three shift. Shifting the code plate to the right is a positive shift, and shifting the code plate to the left is a negative shift. Thus, shifting the code plate two units to the right is a positive two shift from its home position.

Positive Code Plate Stops

- **The stops prevent damage to the code plate through over-shifting.**

Punched codes other than those represented on the keyboard should not be duplicated. Positive code plate stops (see Figure 2-54) are provided to prevent damage to the print mechanism when codes are duplicated other than those associated with characters on the keyboard. Duplicating a column with an 8- and a 9-punch, for example, would drive the print mechanism beyond its vertical tolerance and cause damage. The positive code plate stops, in this case, prevent the vertical shift lever (Figure 2-59) from transmitting the over-shift to the vertical drive rod. *The print switch has no control over this mechanical action, and under no circumstances, should codes other than those represented on the keyboard be duplicated.*

Print Interposers

- **Two sets of print interposers position the code plate.**
- **One set controls the vertical shift, and one set controls the horizontal shift.**

Because the print unit is more accessible from the rear of the machine, directions and description are given from that point of view. The set of interposers to

the left of the punch extensions operates a slide to position the code plate vertically. The set to the right similarly positions the code plate horizontally.

The value of a cam operation of a print interposer (Figure 2-60) appears in whole-number units as plus or minus. The motion imparted to the slides equals the value (stated on the cam) multiplied by 0.020". If a punch (the cam value for which is a +3) operates, the movement imparted to its slide is 0.060". The plus or minus values are etched on the interposer faces.

The motion of each slide (that in turn shifts the code plate) has a ratio of 10 to 11. That is, 0.020" motion to either slide moves the code plate 0.022".

Punch Extensions and Code Plate Shifting

- **The extensions operate the print interposer mechanism on a punch clutch cycle.**

The punch extensions on the printing card punch extend beyond the lower guide (Figure 2-60) to operate the print interposer mechanism. The punch extensions contain the interposer yokes, which operate the interposers. Each yoke is spring operated and positively restored, and is capable of operating two interposers: one vertical, and one horizontal.

In Figure 2-60, assume that the 5 interposer magnet is impulsed after the escapement, the punch bail causes the 5-punch operating arm to raise its punch. As the punch extension lifts, the yoke is forced to rise with it and to slide its print interposer up.

As the print interposer rises, the rollers against which it operates move the horizontal slide +3 (or 0.060") toward the rear of the machine.

Figure 2-59 shows that the rollers in both sides of the interposer unit are under spring tension toward their respective stops (set by adjusting screws). All plus quantities are positively driven (by punch power) away from the fixed stop. Note that the 5-punch interposer positions the code plate horizontally only, because there is no print interposer in the vertical slide assembly for the 5-punch.

For example, the punch code for P is 11-7. The 11-punch moves the code plate two units down (or 0.044") (Figure 2-59). The 7-punch also causes the code plate to move, but it positions the code plate three units (or 0.066") to the left.

Refer to Figure 2-61 to check the combined result.

NOTE: The print wires are a stationary assembly. Therefore, to print from a code plate projection on the left of its home position, the code plate must shift to the right. The same applies to vertical placement of code plate projections. Figures 2-55 and 2-59 show that the top print wires projecting from the code plate form the bottom of the printed letters and vice versa.

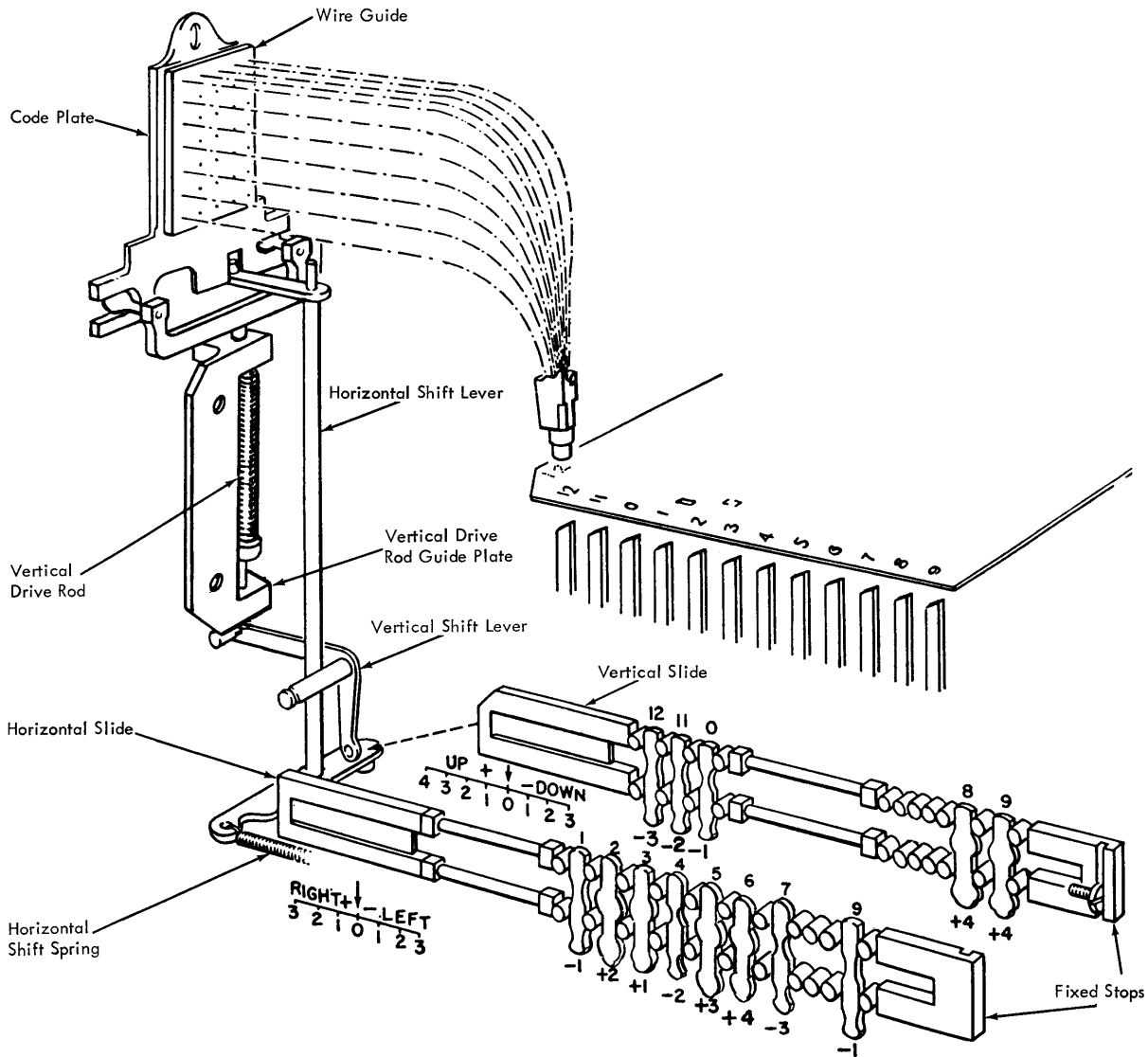

Figure 2-59. Wire Printing

Figure 2-61 is a cut-away view of the upper left corner of the code plate, wire guide plate, and return plate. This section of the EL code plate prints a dot for each of the characters shown in the chart in Figure 2-61. The dot printed for any of the characters shown in the chart is the lowest left corner of the printed character on the card. The code plate is shown in its home position with the print wire restoring head aligned as in a spacing operation.

The 11-7 code results in a code plate shift of left 3 (-3 horizontal), down 2 (-2 vertical). The grid lines in the exploded view of Figure 2-61 locate the center of the projections and the print wire home position. The 11-7 code shifts the code plate to strike the wire shown and form the lowest point (dot) of the letter P.

Print Pressure Plate

- The pressure plate forces the code plate toward the print wires during the printing cycle.

Through linkage with the print arm, the print cam permits the print arm spring to pull down on the print drive connecting link. This downward motion pivots the drive arms about their stationary shafts, and forces the pressure plate (Figure 2-62) and code plate against the print wires. The print cam positively restores the pressure plate.

A return spring at the top of the code plate and two spring driven pressure pins at the bottom repel the code plate from the print wires. These springs make the code plate follow the pressure plate, but still permit the code plate to shift efficiently.

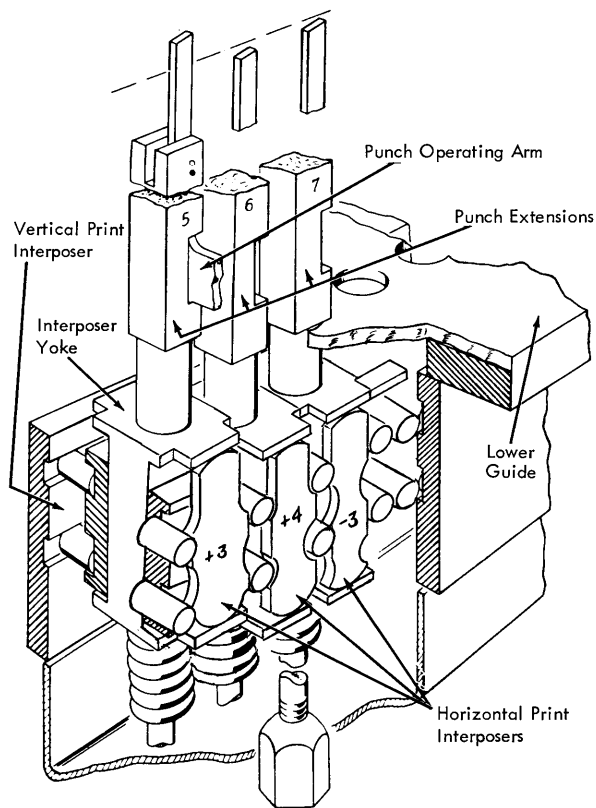

Figure 2-60. Punch Extensions and Print Interposers

Print Suppression Mechanism

- When energized, the print suppression magnet prevents printing.
- The magnet is controlled by the print switch.

The print cam is on the punch shaft outside of the punch index. The print arm and suppression arm are on the punch drive anchor pin extension, and the suppression magnet (Figure 2-63) is directly above.

The print arm is spring operated and cam restored. To prevent printing, an interposer block on the print suppression magnet armature intercepts the movement of the print arm. The print interposers still continue to shift the code plate, but because the pressure plate is not operated, printing is suppressed. The idler arm equalizes the pressure on the punch shaft.

The print suppression arm has a reciprocating motion that the eccentric drive link and eccentric bearing impart to it. The purpose of the suppression arm is to move the interposer block against the print arm, and thus to lift the print arm roller off the print cam. The suppression arm and linkage prevent the print arm follower from bouncing on the approach to the high dwell of the print cam (reducing noise and also elim-

inating the close clearance that would otherwise be necessary between the interposer block and print arm).

The high-speed, print suppression magnet is under control of the print switch. The magnet armature travels at right angles to the yoke because of the suppression arm. A flat spring returns the armature against the stop.

Print Character Pattern Chart

- This chart shows the shift necessary to position the code plate for any character.

Figure 2-64 shows the character patterns for the expanded L(EL) code plate. The chart shows all 62 printable characters, their punch codes, and (along the left and top) the plus or minus shifting of the code plate necessary for each character.

To print a P (see "Punch Extensions and Code Plate Shifting"), first locate the letter P in Figure 2-64. The 11-7 under the P defines the punch code necessary to set up the print interposers. The code plate must be shifted so that the P aligns with the home position (blank). Any character to the right of the home position has a negative horizontal shift, and any character to the left has a positive shift. Any character above the home position has a positive vertical shift, and any character below the home position has a negative shift. The P is located two units down (or a -2 vertical shift) and three units to the right which is a -3 horizontal shift. To print an F, there must be a -3 vertical shift and a $+4$ horizontal shift. To print a %, there must be a $+3$ vertical shift and a -2 horizontal shift.

The 0-8-2 punch code and the space bar do not print a logical graphic. The 0-8-2 code prints a blank with the expanded L code plate; all other code plates print a nine-dot block. The keyboard reference chart on Systems 00.29.10.0 of the wiring diagram shows the combination of keyboard components, the card codes, and the resulting printing associated with each of the keystem positions.

Print Timing Chart

- Shows mechanical timing relationships in degrees and inches.

Figure 2-65 is the print timing chart. The horizontal axis is measured in degrees corresponding to the punch drive unit index. The vertical axis represents thousandths of an inch movement of the various components.

The punch enters the card at 93° on the punch drive index and at this time has traveled approximately 0.125" from its restored position.

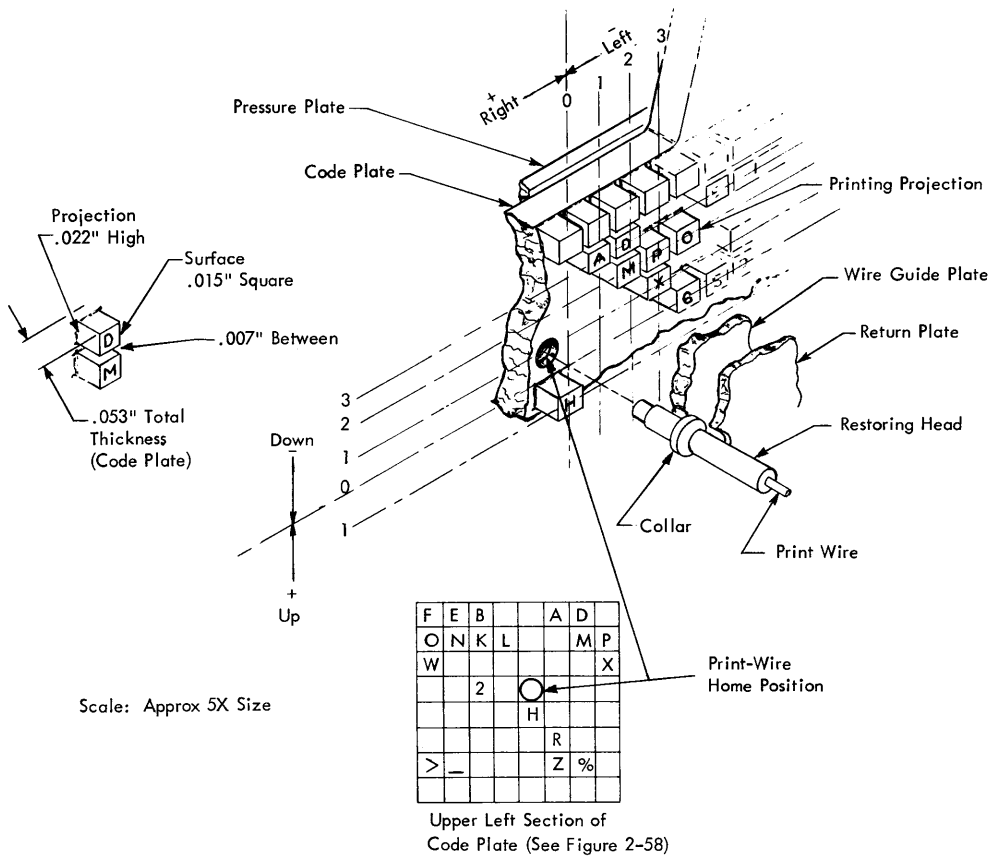

Figure 2-61. Code Plate and Restoring Head

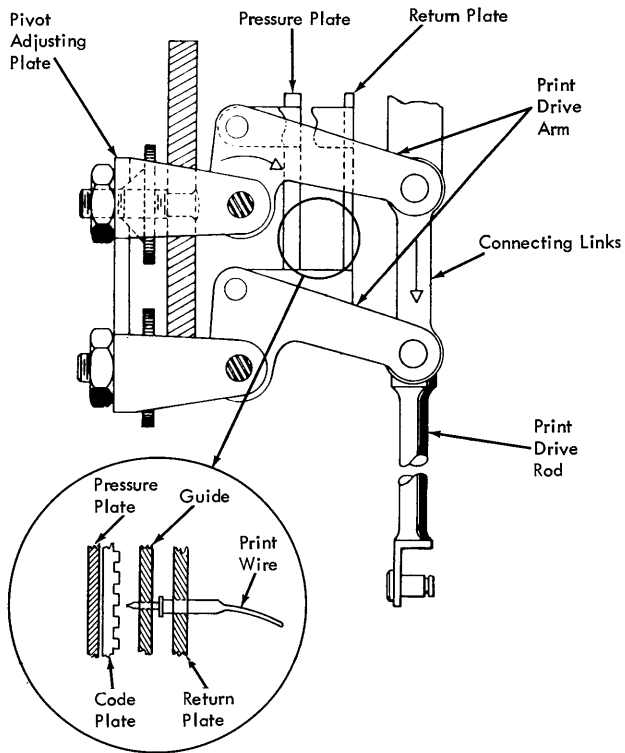

Figure 2-62. Print Drive Rod and Pressure Plate

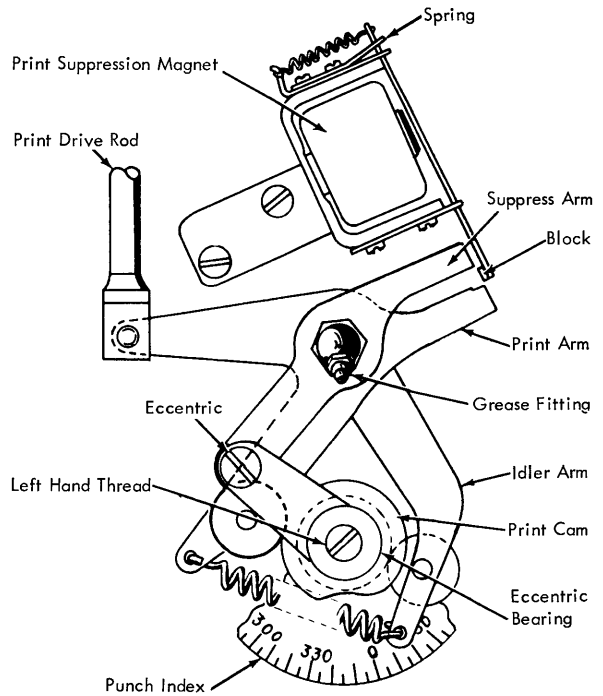

Figure 2-63. Print Suppression

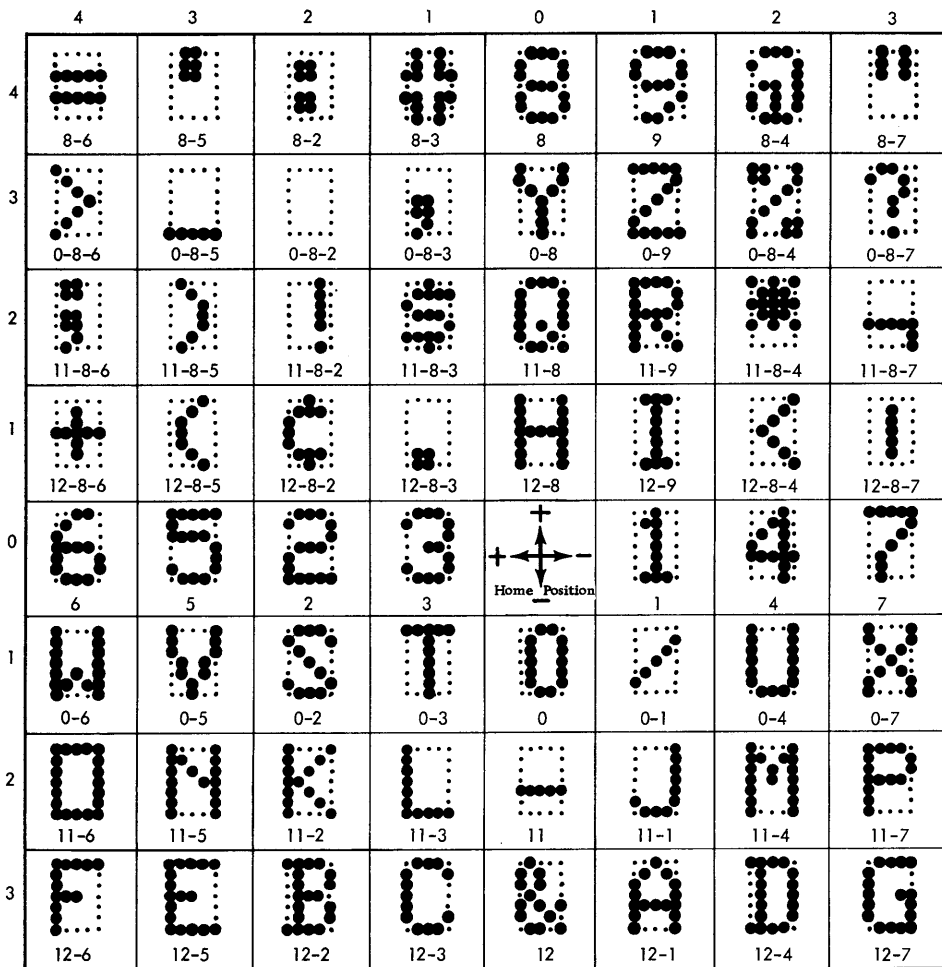

Figure 2-64. Print Character Chart

The pressure plate starts its motion at 100° and stops its motion at 166° of the punch cycle. During the 66° of the punch cycle that the pressure plate is in motion, it moves down toward the tips of the restoring heads approximately $0.100''$.

The pressure plate forces the code plate down $0.050''$ before it contacts the print wires, the print wires are moved down $0.050''$ by the code plate, and the print wire movement occurs between an estimated 115° and 150° of the punch cycle.

The horizontal and vertical interposers are positively restored and spring operated. The code plate is forced down toward the print wires by the pressure plate, and is restored along with the pressure plate.

The restoring heads rest on the return plate and the return plate is operated with the pressure plate. The print wires are restored by the return plate (Figure 2-66).

The cam follower on the print arm starts in the low dwell of the print cam at approximately 95° and is completely out of the low dwell at 170° of the punch cycle.

Ribbon Feed

- The ribbon feeds during each cycle the print unit operates.
- The ribbon is driven through the print drive arms by means of the print drive rod.

The ribbon feed mechanism (Figure 2-67) is a ratchet-type drive consisting of a ratchet stop pawl, a ribbon feed pawl, and a ratchet.

The ribbon is threaded through the ribbon reversing arm, through a ribbon guide, and between the die and stripper. As the end of the ribbon is reached, an eye in the ribbon comes in contact with the ribbon reversing arm. The ribbon reverses its direction when the ribbon reversing arm is pivoted.

Each cycle the print unit operates, the ratchet is advanced one tooth by the feed pawl and is detented by the ratchet stop pawl.

There are two ribbon spindles, one on each side of the ribbon feed unit. The driven ribbon spindle is changed from one to the other as the eye in the ribbon pivots the ribbon reversing arm.

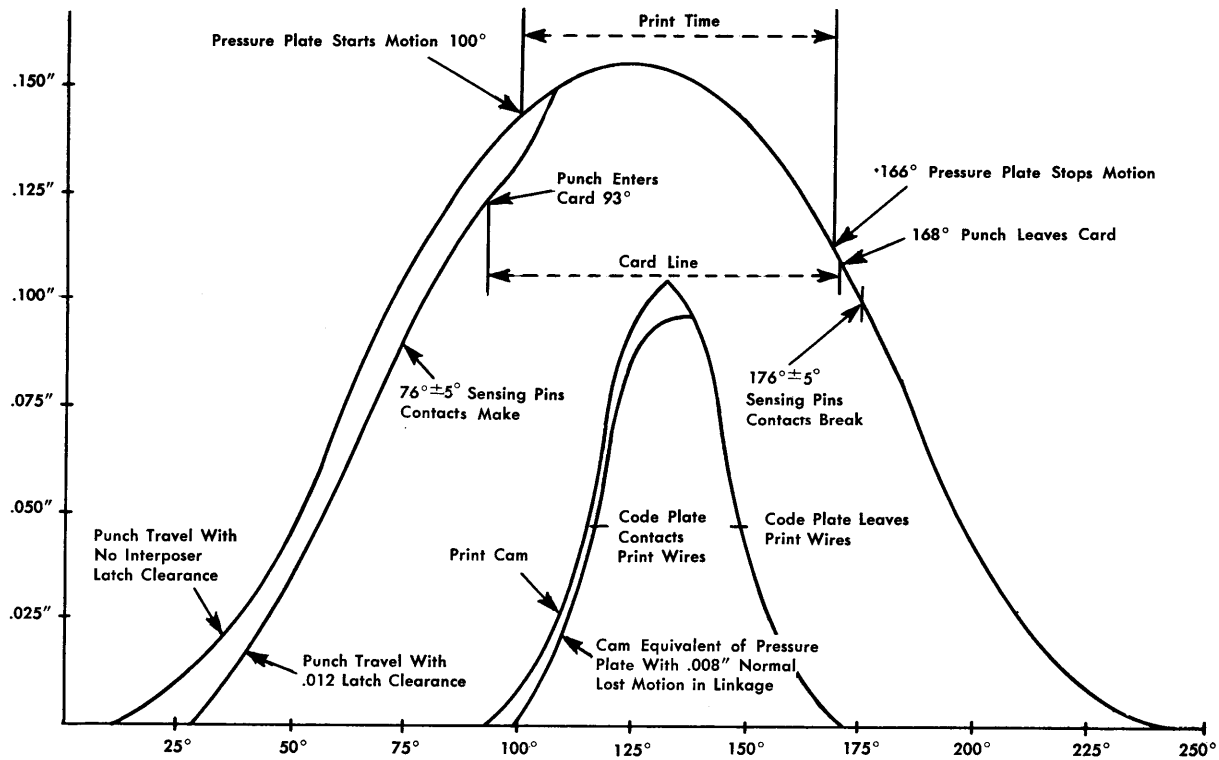

Figure 2-65. Print Timing Chart

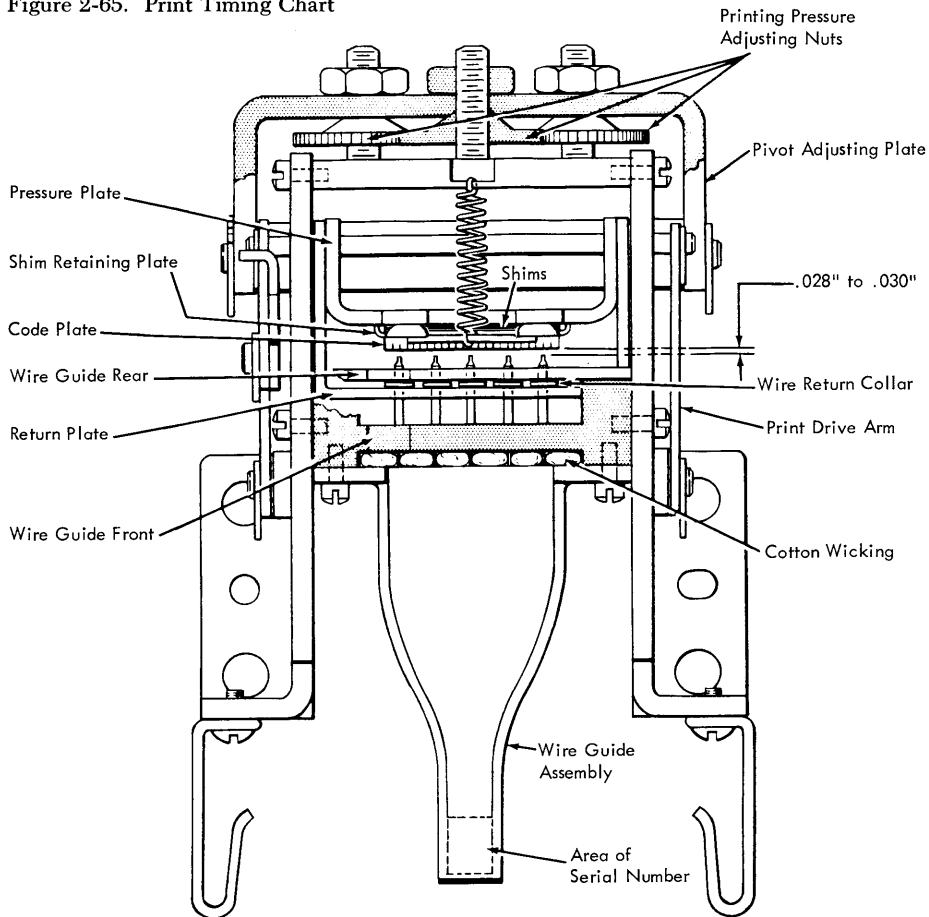

Figure 2-66. Print Unit (Top View)

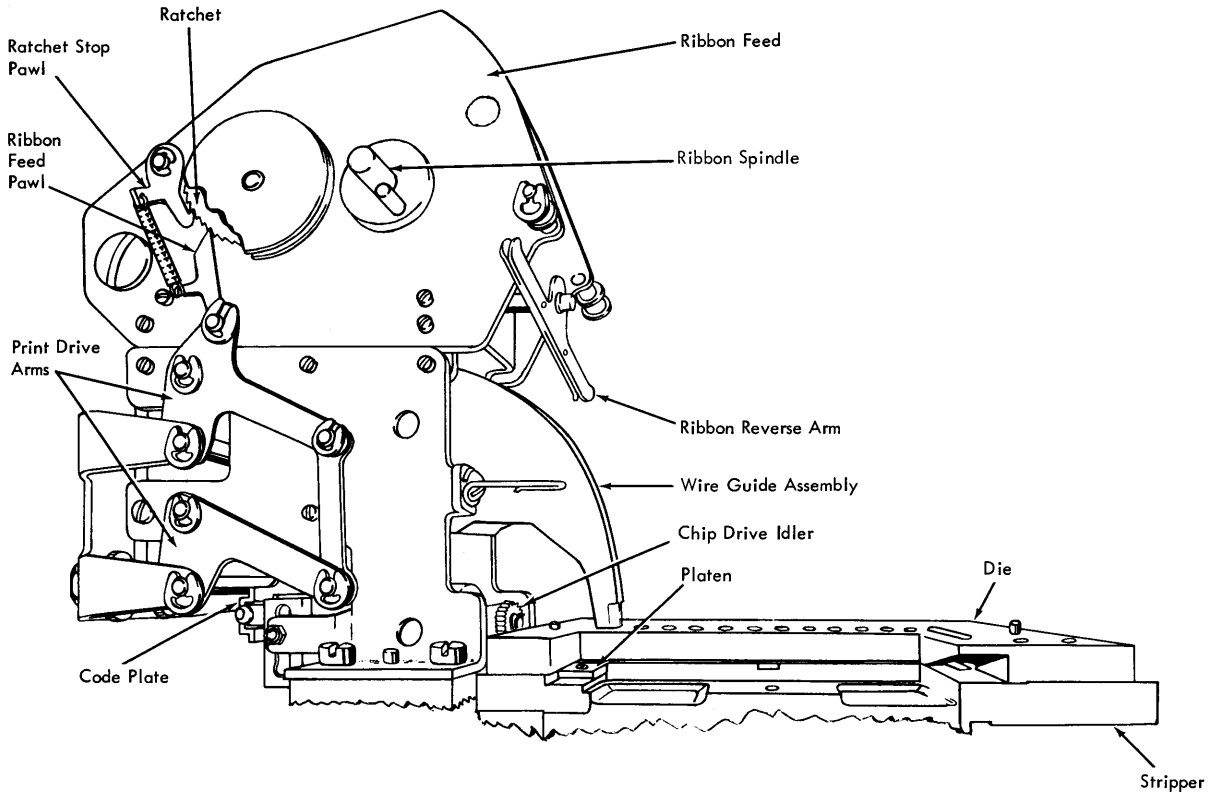

Figure 2-67. Printing

Reed Relay Machines

Manual Punching Operation

- The objectives of manual punching are:
 1. Press a character key.
 2. Escape one column.
 3. Punch the card.
 4. Restore the keyboard.

Description

To punch a card manually in column 1, a card must be registered at the punch station in column 0. With a card registered in the punch station, the card lever relays are picked and holding.

The interposer magnets can be energized from the keyboard during manual punching. Whenever an interposer magnet is energized, the corresponding punch interposer unlatches, and the two interposer bail contacts close in parallel. When the interposer bail contacts close, the escape magnet is energized.

The objectives of manual punching, as stated above, can be illustrated by a logic flow diagram. Figure 3-1 shows the manual punch operation. This diagram shows that pressing the key causes the machine to

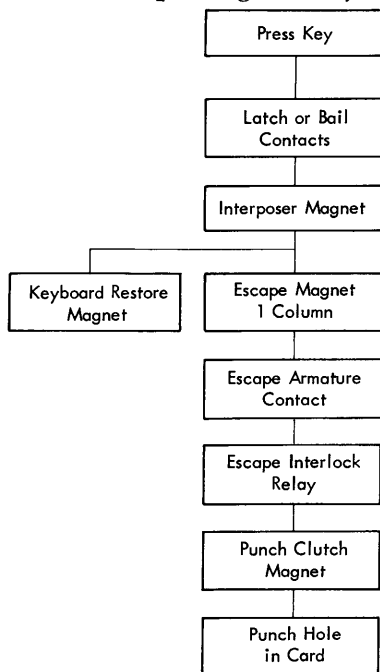

Figure 3-1. Manual Card Punch Operation

escape and then *punch*. Pressing the key also causes the keyboard to *restore*. Figure 3-1 shows all the mechanical and electrical components in the manual punch operation and how one component can cause one or more functions.

Circuit Objectives

Refer to Figure 3-1.

1. Machine escapes one space:
 - Interposer bail contacts.
 - Energize escape magnet.
2. Escapement held to one column:
 - Escape armature contact.
 - Escape interlock relays (N/C point).
 - Drop escape magnet (after one space).
3. Keyboard is restored:
 - Interposer bail contacts.
 - Energize keyboard restore magnets.
4. Punch a hole in card:
 - P2 (M149°-B79°)
 - Escape interlock relays.
 - Energize punch clutch magnet.

Program Levels (Program 1 and Program 2)

- The upper half of the program cards is used for coding Program 1 automatic operations.
- The lower half of the program card is used for coding Program 2 automatic operations.

Description

The program selection switch (PROG SEL) has two positions, identified as ONE (Program 1) and two (Program 2). The setting of this switch determines the program mode that the machine will return to as the column indicator advances from column 80 to column 1. With this switch, the operator can select programming mode 1 or programming mode 2 for each card.

The PROG ONE (program 1) key and the PROG TWO (program 2) key operate in conjunction with the program selection switch. These two keys have two different operations, depending on where in the cycle they are pressed. If a program key is pressed in column 1 or any succeeding column, the machine is shifted to that program mode for the duration of the card, or until the other program key is pressed. By using these keys, it is possible to change from program 1 to pro-

gram 2 and vice versa anywhere within the card. The program keys also operate in conjunction with the automatic feed switch. If the automatic feed switch is turned off, when the card is processed to column 80, the column indicator advances to column 1. However, an automatic feed cycle is not initiated. In this situation, pressing either the program 1 key or the program 2 key initiates a feed cycle and sets the machine to the corresponding mode.

The program select relays, to pick and hold, must have an approximate +48 voltage potential. When the relays are picked, the machine is in program 2 mode. When the relays are not energized (dropped), the machine is in program 1 mode.

Program 1 control circuits are wired to the negative side of the program select relays. When +48 volts is applied to the negative side of the relays, they are dropped. The relay points in the starwheel control circuits must be normal (dropped) for program 1 control. This allows the upper half of the program card to be read. When the relays are picked, the relay points transfer and the lower starwheel circuits read the lower half of the program card.

The program select relays are picked by either the program 2 key or through the program select 2 switch and are held through their own points.

If the auto feed switch is on and column 80 of a card is punched, a normal feed cycle takes place and the program mode reverts automatically to the position of the program select switch. This is accomplished by routing the circuit from PCC2 N/O through the auto feed switch ON, and through the program select switch, to both the CF clutch magnet and the program select relays. The program select switch in either program 1 or program 2 position has a parallel path to the CF clutch magnet to provide for an auto feed cycle. The program select switch on a manual feed or auto feed cycle controls the pick or drop of the program select relays.

If the auto feed switch is off and column 80 of a card is punched, the card in the punch station is released to the master station and the card in the detail station is not registered. This is a normal operation (card-to-card skip) with the auto feed switch off. There is a card at the master station ready to be registered in the read station, and there is a card in the detail station ready to be registered at the punch station. Under these conditions, pressing the program 2 key causes:

1. The program select relays pick.
2. The CF clutch magnet is energized.
3. The card in the master station is registered in the read station.
4. The detail card is registered in the punch station.

5. A card is fed from the hopper to the detail station.

The machine is ready for further operations in program 2 mode, because the program select relays are picked.

If the program 1 key is pressed under the previous conditions with the auto feed switch off, the program select relays have +48 volts applied to the negative side of the coils and drop them out.

Steps 2-5 are the same as when pressing the program 2 key, but the machine is in program 1 mode.

Figure 3-2 shows the basic logic flow of program 1 and program 2 selection. Figure 3-3 is a second level (AND-OR) logic of the program selection operation.

Circuit Objectives

Program 1: To shift the program control from the lower half of the program card to the upper half (refer to wiring diagrams):

1. Drop program select relays 106 and 115. (8A)
Apply +48 volts to 0 volt side of relays 106 and 115.

Program 1 key. (7A)

Program 2: To shift the program control from the upper half of the program card to the lower half:

1. Pick program select relays 106 and 115. (8A)
Program 2 key. (7A)
Hold through 115-1. (8A)

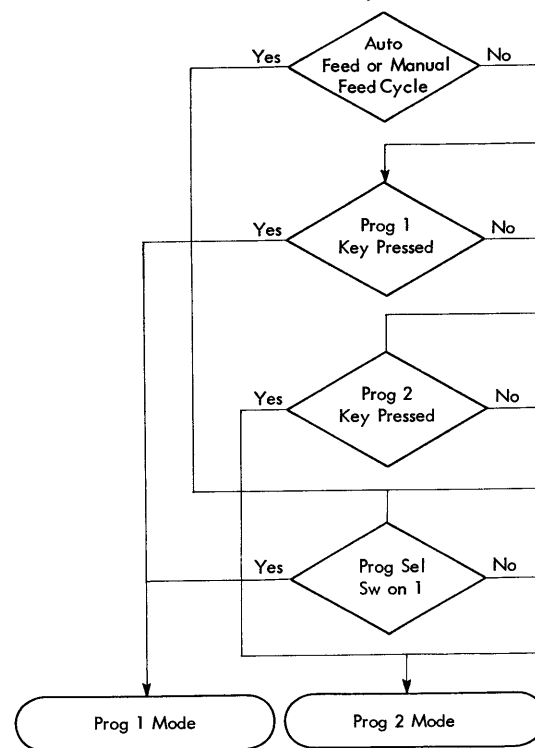

Figure 3-2. Program Selection

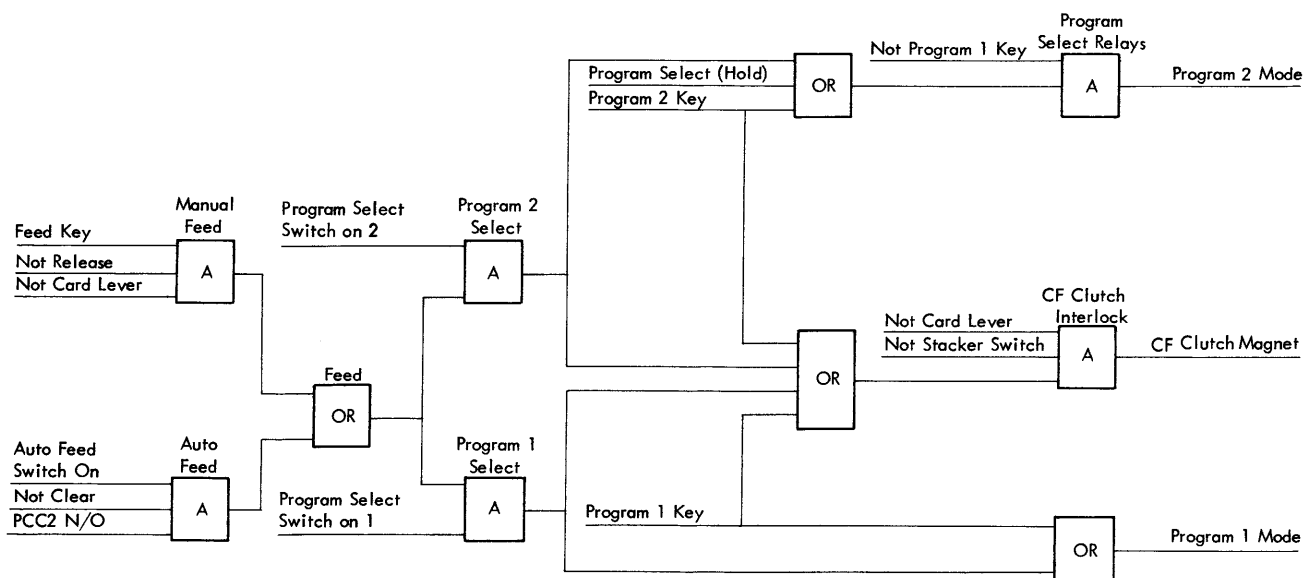

Figure 3-3. Program Selection

2. Read (sense) only lower half of program card. 106 and 115 points transferred.

End of Card – Auto Feed Switch On: To return the program mode to the position of the program select switch during an auto feed cycle:

1. Energize CF clutch magnet. (6A)
Stacker switch N/c. (6A)
Card lever 110-3 N/c. (8A)
Program select switch on 2. (7A)
Auto feed switch on. (6A)
Clear 108-2 N/c. (5A)
Clear 107-3 N/c. (5A)
PCC2 N/o. (5A)
2. Pick program select relays 106 and 115. (8A)
Parallel from PCC2 N/o, same as before, but through diode 105 CR5. (8A)
3. Hold program select relays 106 and 115. (8A)
115-1 to +48 volts. (8A)

End of Card – Auto Feed Switch Off: Advance column indicator to column 1 and prevent CF cycle:

1. Normal card to card skip:
PCC1. (9B)
 2. Prevent CF cycle:
PCC2 circuit open. (5A)
Auto feed switch off. (6A)
- Initiate feed cycle:
1. Energize CF clutch magnet. (6A)

- Stacker switch N/c. (6A)
Card lever 110-3 N/c. (8A)
Program 2 key. (7A)

Set machine to program 2 mode:

1. Pick program select relays 106 and 115. (8A)
Program 2 key. (7A)
2. Hold program 2 relays 106 and 115. (8A)
115-1 to +48 volts. (8A)

Error Reset

The error reset key energizes the keyboard restore magnets. This key has N/o and N/c keystem contact points. Plus 48 volts is supplied the N/c points through the N/c backspace switch to +48 volts at TB2-5 in the power supply. The voltage distribution is shown in the wiring diagram. (35A, 36A)

Pressing the error reset key (8A) energizes the keyboard restore magnets through the N/o error reset keystem contact. (8A)

Feed Key

- The feed key causes cards to feed from the hopper, register at the punch or read stations, and move up into the stacker.

- **The feed key (keystem) contact voltage is controlled through N/C card lever relay points.**

Pressing the feed key energizes the card feed clutch magnet. This initiates a CF (card feed) cycle, and a card feeds from the hopper to the detail station. Holding the feed key pressed initiates a second CF cycle, registering the first card in the punch station and feeding a second card to the detail station. Either the feed key or register key will register a card at the punch or read stations, and will cause a card leaving these stations to enter the stacker.

The feed key is operative only when there is no card registered at the punch station. This is because the N/C card lever relay points in the CF clutch magnet circuit open when the card lever relays are picked. This prevents energizing the CF clutch magnet through the feed key keystem contact.

Cards move through the machine as described below:

1. Pressing the feed key twice (or one long depression) executes two CF (card feed) cycles and registers a card at the punch station.
2. When the auto feed switch is on and the punching of the first card is completed, the third CF cycle is automatic.
3. The third CF cycle registers the first card at the read station, registers the second card at the punch station, and feeds a third card from the hopper to the detail station.
4. After punching the second card, the second auto feed cycle occurs.
5. The first card is ejected from the read station and stacked.
6. The second card is registered at the read station, the third card is registered at the punch station, and the fourth card is fed from the hopper to the detail station.
7. In four CF cycles the card has moved from the hopper, through the punch station, through the read station, and has been stacked.

The following feed key operation is described as a card is fed from the hopper and registered in the punch station. Two separate (momentary) feed key depressions are described to show two card feed cycles. The same operation also takes place when the feed key is held pressed for two card feed cycles.

Feed Key — First Depression

- **A card is moved from the hopper to the detail station.**
- **Punching is not possible.**
- **The keyboard is restored.**

Description

Pressing the feed key causes a card to move from the hopper to the detail station. Punching and all automatic functions are made operative when the card lever relays are energized. The card lever relay is energized through the detail card lever contact. As the card moves to the punch station, the action of the card passing between the upper card rail and the pressure rails causes the detail card lever contact to close (make) at 10° of the CF cycle. Once the detail card lever is made, the detail card lever contact stays closed as long as there are cards in the punch station.

The circuit to energize the card lever relays is through CF3 and the detail card lever contact. On the first card feed cycle, CF3 breaks before the detail card lever contact makes. Therefore, on the first card feed cycle, the card lever relays will not be energized. N/C card lever relay points prevent energizing the CF clutch magnet after the card lever relays are picked.

Circuit Objectives

1. Feed a card from the hopper to the punch bed on the first momentary depression of the feed key:
 - Energize card feed clutch magnet. (6A)
 - Feed key contact.
 - Card lever contact closes at 5° to 10° of CF cycle. (7B)
2. Card lever relays are *not* energized (punching is not active). (8B):
 - CF3 breaks (M70°-B150°) before card lever contact makes (10° of the second cycle). (7B)

Feed Key — Second Depression

- **The second card is moved from the hopper to the punch bed.**
- **The first card registers for punching.**
- **Punching and all automatic functions become operative.**
- **Restores the keyboard.**

Description

Pressing the feed key the second time causes the first card to be registered at the punch station and the second card to feed from the hopper. With a card in the punch station, the detail card lever remains closed, and provides a circuit to the card lever relays from +48 volts through CF3 (M70°-B150°).

The card lever relays make punching and all automatic functions operative because their points transfer +48 volts to all these circuits. The card lever relays remain picked under control of the program drum.

The program drum moves in unison with the card. The program cam contacts control the card lever relay

hold circuit. Program cam contact 2 N/C makes between column 87½ and 88½ on the column indicator, and breaks between column 82½ and 84. This means that program cam contact 2 N/C point is closed all the time that a card is being processed. The card lever relays hold for a few columns beyond column 80. Program cam contact 2 is timed so that the card lever relays drop out somewhere between columns 82½ and 84.

Feeding a third card is not possible because N/C card lever relay points open the circuit when the card lever relays are holding.

Circuit Objectives

1. Register first card and feed next card from hopper:

Energize card feed clutch magnet. (6A)

Feed key contact. (6A)

2. Pick card lever relays 110 and 112. (8B)

CF₃ (M70°-B150°). (7B)

(Detail card lever contact was closed by first card).

3. Hold card lever relays 110 and 112. (8B)

PCC₂. (5A)

Card-to-Card Skip (Auto Feed Switch On)

- A card-to-card skip occurs as the program drum moves out of column 80.
- This skip is controlled by the skip relay, escape magnet, and program cam contact 1 (PCC₁).
- The circuit to pick and hold the skip relay and escape magnet is through PCC₁.
- PCC₁ breaks at column 88-1/6 and stops the program drum in column 1.
- With the auto feed switch on, the circuit to energize the CF clutch magnet is through PCC₂.

The card-to-card skip circuits are established as the drum moves out of column 80. The skip continues until the drum is in column 1. The operation to move the program drum from column 80 to column 1 is similar to a release operation. As the drum moves out of column 80 for any reason, either punching or releasing, the skip relay is energized. It, in turn, picks and holds the escape magnet until column 1 is reached.

When a character key or the release key is pressed, the program drum moves out of column 80. At column 80½, the skip relay is energized through PCC₁ (program cam contact 1), which makes at column 80½ to 80¾ and breaks at column 88½. With the skip relay energized, the escape magnet picks through skip N/O

points and uses the same circuit as the skip relay. Both the skip relay and escape magnet hold under control of PCC₁ until column 88½.

When the program drum moves past column 88½, both the skip relay and escape magnet drop, and the program drum stops in column 1. As the program drum moves from column 80 to column 1, a card is fed automatically from the hopper if the auto feed switch is on.

To feed cards automatically, the CF clutch magnet circuit is completed through the auto feed switch in the ON position, from PCC₂ normally open side, and +48 volts.

NOTE: The make and break timings of PCC₂ (program cam contact 2) refer to the normally closed contact. These timings are reversed for the normally open contact. Shortly after the operating point breaks away from the normally closed contact, it makes on the normally open side. PCC₂ makes on the normally open side at column 82½ to column 84, and breaks on the normally open side at column 87½ to column 88½. Therefore, on a card-to-card skip operation with the auto feed switch on, the CF clutch magnet will be energized at column 82½ to 84.

Register Key

- Registers a card at the punch and/or read stations without feeding a card from the hopper.
- Makes punching and all automatic functions operative.
- Restores the keyboard.

Description

The register key performs all the functions of the feed key, but prevents the feeding of cards from the hopper by the action of the card feed latch magnet. Energizing the CF latch magnet causes the CF latch contact to close and supply +48 volts to the CF clutch magnet.

The CF clutch magnet operates the CF mechanism. The mechanical action of the CF latch magnet prevents the feed knives from moving downward, and no cards feed from the hopper. Even though a new card did not feed from the hopper, the card in the punch station closes the detail card lever contact, and the card lever relays pick at about 10° of this CF cycle.

Circuit Objectives

1. Energize CF latch magnet (initiates a CF mechanical cycle):

Register key latch contact. (6A)

2. Energize CF clutch magnet (causes CF mechanism to operate):

Card feed latch contact. (6A)

3. Pick card lever relays 110 and 112 at 70° of this cycle:

Detail card lever contact (closed from first card). (7B)

4. Hold card lever relays 110 and 112. (8B)

Card lever relay points 112-1 N/O. (7B)

PCC2 N/C. (5A)

5. Energize keyboard restore magnets:

CF4. (7A)

Backspace Key

- **The backspace key moves any registered card backwards, a column at a time, but not beyond column 1.**
- **The program unit is also backspaced in sequence with the card.**
- **The backspace key restores the keyboard.**
- **Refer to “Functional Units” for detailed mechanical operation.**

Backspacing sequence of operation:

1. Press the backspace key. (35A)

2. The control circuits are opened.

3. The keyboard is restored as the actuating arm transfers the backspace switch.

4. The actuating arm ear allows the cam engaging arm to go under control of the six-lobe cam.

5. Reverse card movement occurs because the cam-operated arm pivots and moves the pawl up and down.

6. When the pawl and the ratchet are meshed, the escape mechanism moves in reverse, and backspacing is detented by the escape armature.

Duplication

- **Duplication means sensing the holes in the master card and reproducing them in the detail card.**
- **There are two methods of duplication: manual and automatic.**

Description

Manual duplication is initiated by pressing the dup key without field definition. The punch unit goes through two cycles of operation for each column duplicated.

Automatic duplication is initiated by the starwheels sensing a 0-hole in program 1, or a 6-hole in program 2, in the program card. The punch unit must go through two cycles of operation for the first column duplicated, and one cycle thereafter.

Dummy Punch Clutch Cycle

- **This is the first of two punch clutch cycles. It is used to read the holes in the card at the read station, and store this information mechanically in the punch unit.**
- **The second punch clutch cycle is used to punch the stored information into the blank card at the punch station.**

Dummy punch clutch cycle is a common term used for the first cycle in a duplication operation. During the first punch clutch cycle, no punching occurs. The punch unit is made operative for the purpose of controlling the action of the pin sense unit and using the P-cam timings. Because no punching occurs, this cycle is called the dummy punch clutch cycle. The operation is explained in “Manual Duplication Sequence Chart.”

Manual Duplication (One Column, Program Control Off)

- **The punch unit must go through two cycles of operation for every column duplicated.**
- **A card can be manually duplicated by:**
 1. **Registering a punched card at the read station.**
 2. **Registering a blank card at the punch station.**
 3. **Pressing the dup key (duplication key).**

Description

The first punch cycle (dummy) is used to read the holes in the card at the read station and store this information (mechanically) in the punch unit. The second punch cycle is used to punch the stored information into the blank card at the punch station. This action occurs when the dup key is pressed.

For the following manual duplication operation, assume that program control is off (starwheels raised), the card punch is in alphabetic shift, and cards have been fed and registered. The program drum and master card are registered in column 1. The detail card is always one column behind the program drum and master card; therefore, it is registered in column 0. With the cards and program drum in this position, duplication can take place. The objectives of manual duplication with program control off are:

1. Press the dup key. (9A)

2. Restore the keyboard.

3. Read the master card (dummy punch clutch cycle).

4. Escape.

5. Punch.

Figure 3-4 shows a simplified block diagram and a sequence chart of the manual duplication operation with program control off.

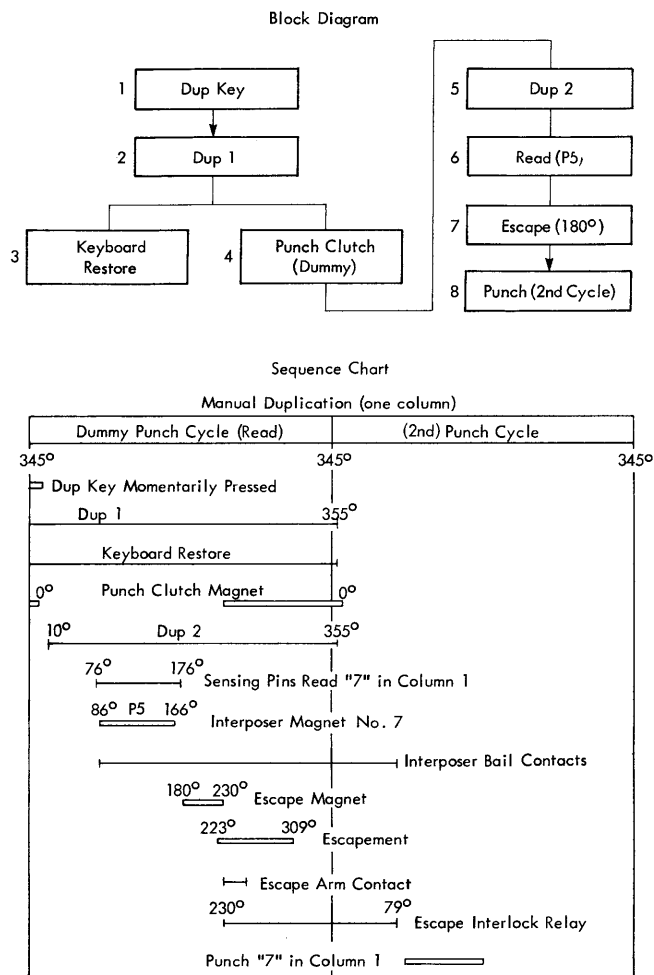

Figure 3-4. Manual Duplication (Program Control Off)

The dummy punch clutch cycle is used to read the card at the read station. During this cycle, the dup-2 relay is picked. This completes a circuit through the sensing pin contacts to energize the proper interposer magnets. During this first punch clutch cycle, no punching occurs. The punch unit is made operative for the purpose of controlling the action of the pin sense unit.

After the interposer magnet is energized, the operation is similar to manual punching. Energizing an interposer magnet closes the interposer bail contacts and energizes the escape magnet. The escape magnet allows the cards to move and closes the escape armature contact, which picks the escape interlock relay. The escape interlock relay opens the circuit to the escape magnet and allows the escape magnet armature to fall back in the next tooth on the escape wheel. This relay also energizes the punch clutch, and the information read on the previous cycle is punched into the corresponding column at the punch station.

Circuit Objectives

Refer to Figure 3-4. The digit 7 is punched in column 1 of the master card. This card is registered in column 1, and the detail card is registered in column 0. Manually duplicate column 1:

1. Energize dup-1 relays 114 and 116. (10A)
Dup keystem contact. (9A)
2. Energize the punch clutch magnet. (12A)
116-2. (11A)

The punch unit now begins to operate in preparation for reading the card.

NOTE: This completes through the 4 block and begins the dummy punch clutch cycle on the sequence chart (Figure 3-4).

3. Energize the keyboard restore magnets. (8B)
114-1. (7B)

The keyboard is held restored until dup-1 relays 114 and 116 drop out. (10A)

4. Pick dup-2 relays 120 and 122 at 10°. (10A)
116-1. (10A)
P3 (M10°-B60°). (9A)

5. Hold dup-2 relays 120 and 122. (10A)
122-4. (10A)
116-4. (10A)
131-4 (not escape interlock). (9A)
112-6. (9A)

6. Hold dup-1 and dup-2 relays either through the escape interlock relay or P4 until 355° of the next punch cycle.

122-4 (for hold on dup-2 relays only). (10A)
116-4. (10A)
P4 (M175°-B355°). (9A)

7. Energize the 7-interposer magnet.

- a. The punch shaft is turning.
- b. The sensing pins are rising.
- c. The master card is read. There is a 7 in the column to be duplicated. The 7-sensing pin contact reads the 7-hole in the master card.

120-1. (1B)

P5 (card at read station is read between 86° and 166°). (1B)

The interposer is unlatched but fails to hook on the punch bail because it has already started downward.

NOTE: This completes block 6 and about ½ through the dummy punch clutch cycle of the sequence chart (Figure 3-4).

8. Close interposer bail contacts. (9B)

Energizing the interposer magnet unlatches the interposer, which closes the interposer bail contacts.

9. Energize escape magnet when the punch shaft gets to 180°. (10B)

- a. The punch shaft is approaching the halfway point of its first revolution.
- b. At approximately 176° the sensing pins are lowered away from the card.
- c. P1 makes at 180° and the escape magnet operates (through the interposer bail contacts). (12A)
- d. Both cards escape one column.
- e. The master card is now registered in column 2.
- f. The detail card is registered in column 1 and is ready to be punched on the next punch cycle.

NOTE: This completes block 7 and ¾ through the dummy punch clutch cycle of the sequence chart (Figure 3-4).

10. The keyboard restore magnets are energized. (8B)

114-1 points are transferred. (7B)

From here on, the operation is similar to manual punching.

11. Pick escape interlock relays 131 and WCR1. (12A)
Escape armature contact. (11A)

12. Relays 131 and WCR1 hold until 79°. (12A)
131-1. (11A)
P2 (M149°-B79°). (11A)

13. Energize punch clutch magnet. (12A)
WCR1-4. (10B)
Escape armature contact. (11A)

The punch unit is now approaching the end of its first cycle of operation. The punch clutch magnet is energized until P1 breaks at 0° of the next punch cycle. The clutch sleeve does *not* latch on the tip of the magnet armature, and the punch unit continues into another cycle of operation.

During this second punch cycle, the previously tripped-off interposers are hooked on the bail. The 7-hole is punched in column 1 of the card at the punch station.

14. Keyboard restore magnets drop at approximately 79°. (8B)

Interposer bail contacts. (9B)

15. Escape interlock relays drop at 79°. (12A)
P2 breaks at 79°. (11A)

As the punch bail returns to normal, the interposer that was hooked on the bail is restored on its armature.

This completes the block diagram and the sequence chart (Figure 3-4).

The digit 7 has been manually duplicated from the master card into the detail card.

Manual Duplication Sequence Chart

- **Figure 3-4 (Sequence Chart) shows two punch clutch cycles.**

- **Both punch clutch cycles start at 345° because this is where the punch clutch is latched.**
- **Digit 7 is being read in column 1 of the master card and duplicated into column 1 of the detail card.**

Pressing the dup key starts a manual duplication operation. At this time, the punch clutch shaft is latched at 345°. Pressing the dup key picks the dup-1 relays which stay energized until 355° of the following punch clutch cycle. The dup-1 relays energize the keyboard restore magnets and the punch clutch magnet. The dup-2 relays pick at 10° and stay energized until 355° of the following punch clutch cycle. The dup-2 relays complete a circuit to the pin sense contacts and interposer magnets. Therefore, these relays must be energized to read a card at the pin sense unit (read station).

The punch shaft continues to turn and allows the sensing pins to rise and read the card between 76° and 176° as shown in the mechanical timing chart (Figure 2-14). A pin going through the 7-hole in column 1 of the card allows a CB to energize the 7 interposer magnet between 86° and 166° of the punch cycle. The 7 interposer will not hook onto the punch bail because the punch shaft is turning and the punch bail has already started down.

The tripped off interposer closes the interposer bail contacts. In a manual punch operation, this would immediately give an escapement because the punch clutch is at 345° and P1 is closed. During this manual duplication operation, the interposer bail contacts transfer at approximately 86°. The punch shaft is turning but the escape magnet is not energized until 180° of this punch cycle because P1 supplies the +48 volts to the escape magnet.

The reason for waiting until 180° before an escapement can take place is to delay movement of the card until the sensing pins leave the holes in the card. The sensing pins are raised and reading the card from approximately 76° to 176°. If the card moves before the pins leave the holes in the card, the card movement will be restricted. Even if there are no holes in the card, the pressure of the pins against the card will hold the card back if an escapement is attempted at this time.

Mechanical Relationship — Punch Index and Escapement

- **The sensing pins read the card from approximately 76° to 176°.**
- **Escapement does not take place until 180° of the punch cycle because P1 does not make until this time.**

- **When P1 makes, the sensing pins have been lowered and the card is free to move.**

Description

An approximate mechanical relationship between the punch index and escapement can be established. This relationship will show that the escape magnet is energized for approximately 50° of the punch cycle.

To arrive at this relationship, the following information is given: the punch unit operates at 1,200rpm or 20 revolutions per second; therefore, a punch unit travels 7,200° per second or 7.2° per millisecond. When the release key is pressed, the escapement can travel from column 1 to column 1 (86 teeth on the escape wheel) in approximately 1 second. This means, that one tooth on the escape wheel moves past a given point in approximately 12 milliseconds (Figure 3-5).

It takes approximately 6ms to move the escape armature out of the tooth of the escape wheel and another 3ms to pick the escape interlock relay and break the escape magnet circuit. Therefore, the escape magnet is energized approximately 7ms, or 50°, or from 180° to 230° of this punch clutch cycle. This is shown on the sequence chart in Figure 3-4.

During a duplication operation, the escape wheel moves past a given point at an approximate rate of 12ms per tooth. The movement of one tooth on the escape wheel requires 12ms or 86° on the punch clutch index. The escapement takes place from approximately 223° to 309° of this punch cycle.

The escape magnet closes the escape armature contact and energizes the escape interlock relays at about 230°. The pick impulse lasts 8ms (57°) or until 287°. The escape interlock relays then hold until 79° of the next punch clutch cycle.

As soon as the escape interlock relays pick, the punch clutch magnet is energized in preparation for the next punch cycle and stays energized until 0° of the next cycle. A tripped off interposer cannot be restored until it hooks onto the bail and is pulled down

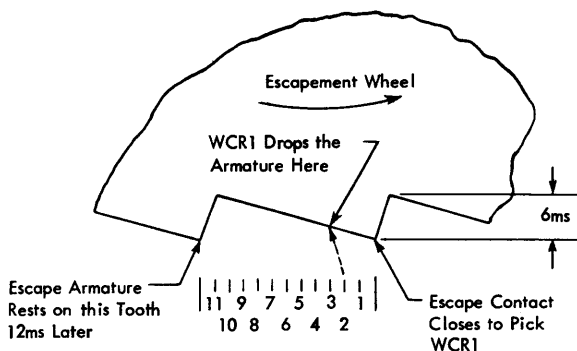

Figure 3-5. Escapement Timing

below the notch in its associated interposer magnet armature. In the following paragraph the 7 interposer trips off but does not hook on the bail.

The punch clutch shaft is still turning. The tripped off 7 interposer, which does not hook on the bail the first time, now hooks on at approximately 220° as the punch bail returns to its normal position. As we approach 345°, the escape interlock relays are still energized and another punch clutch cycle is initiated.

The first cycle was the dummy punch cycle because no punching took place; the second cycle is the actual punch cycle. It was initiated because the punch clutch magnet is energized before 345° through the escape interlock relays, therefore the punch clutch will not disengage.

During this second cycle, the 7-hole that was read on the first cycle is punched into column 1 of the card at the punch station. Dup 1 and dup 2 and the keyboard restore magnets all drop at 355°. The escape interlock relays drop at 79°. The punch unit latches at 345°, as the 7 interposer is restored.

Manual duplication (Figure 3-4) can be summarized as follows:

1. Pressing the dup key picks the dup-1 relay.
2. This relay holds the keyboard restored and starts a dummy punch clutch cycle.
3. During this cycle, the dup-2 relay is picked, and the card is read by the pin sense unit in the read station.
4. An escapement occurs which causes another punch clutch cycle.
5. The information is punched and the operation is completed.

Manual Duplication (More Than One Column)

- **Holding the dup key pressed continues manual duplication.**
- **Two punch cycles are required for each column duplicated.**
- **Cards are alternately read on one cycle and punched on the next cycle.**
- **Figure 3-6 is a sequence chart that shows two columns of information being duplicated, and four punch cycles.**
- **The first and third cycles are dummy punch cycles, and the second and fourth are actual punch cycles.**

Description

During the first cycle of operation, the card is read between 86° and 166°. The escape magnet is energized at 180°. This occurs just as it did on the single-column manual dup operation.

During the second cycle of operation (Figure 3-6), punching takes place as before. However, unlike the single-column dup operation (see Figure 3-4), the dup key is held pressed. The dup-1 relays and keyboard restore magnets are again energized at 79° as a result of dropping the escape interlock relays.

During the second cycle, *the card is not read*. The dup-2 relay points are open and there is no circuit to energize the interposer magnets. The pick of dup-2 relay 120 is controlled by the dup-1 relay and P3. Since dup 2 must be picked before 60° of *any* punch cycle, and dup 1 is not picked until 79° of *this* punch cycle, dup 2 cannot be picked and the card at the pin sense station is not read at this time.

This is why a card is not read on the actual punch cycle in a manual dup operation and also why an auto dup operation is twice as fast as a manual dup operation. During auto dup operations there is a circuit to keep dup 2 energized for the entire operation.

Circuit Objectives

Refer to Figure 3-6.

1. First cycle of operation occurs as it did on the single column dup operation:

- a. The card is read between 86° and 166°.
 - b. The interposer magnets are energized.
 - c. The escape magnet is energized at 180°.
 - d. The punch clutch magnet is energized at 230°.
 - e. The card is not punched.
2. Second cycle of operation:
- a. The card is not read.
 - b. The punch clutch magnet is energized at 180°.
 - c. The card is punched.
 - d. The dup key is held pressed.
- Pick dup-1 relays 114 and 116 and energize keyboard restore magnets at 79°. (10A, 8B)
 131-5 (normal).
 P2 drops escape interlock relays at 79°. (11A)
 Dup keystem contact. (9A)
 Dup-2 relays 120 and 122 are not picked.
 Dup-1 relays 114 and 116 dropped at 355°. (10A)
 116-1 open until 355° (10A)
 P4 breaks at 355°. (9B)
 120-1 prevents circuit to interposer magnets. (1B)
 Dup-1 relays 114 and 116 repick at 79° of second cycle. (10A)
 Dup keystem contact. (9A)
 131-5 is normal (10A)

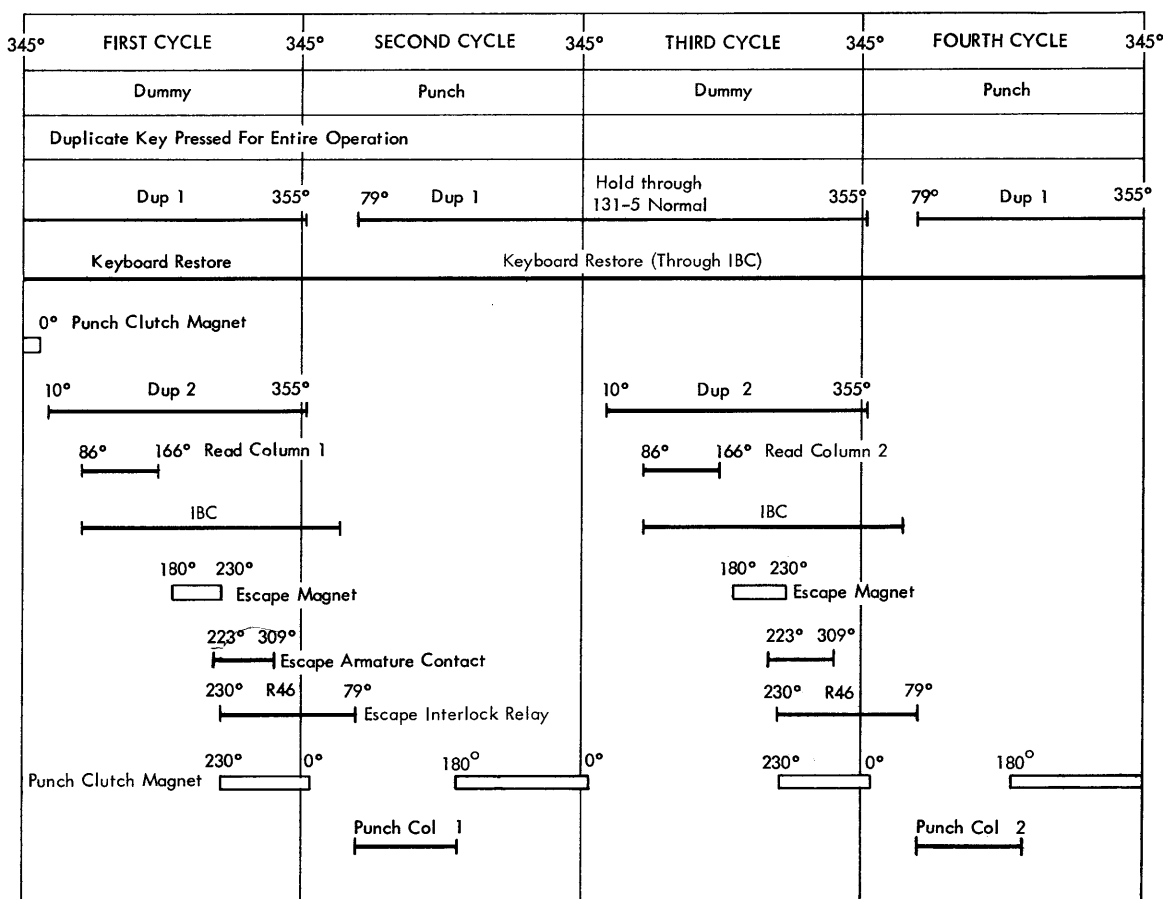

Figure 3-6. Manual Duplication (More Than One Column)

Relays 131 and wcr_1 are normal from 79° of the second cycle to approximately 230° of the third cycle, allowing a hold circuit for relays 114 and 116 through 131-5 points.

3. Third cycle of operation:

Escape interlock relays 131 and wcr_1 are normal until 230° . (12A)

Dup-1 relays 114 and 116 hold from 79° of second punch cycle until 355° of fourth cycle. (10A)

P4 (M175°-B355°). (9B)

Card at read station is read and cards escape.

Dup-2 relays 120 and 122 picked. (10A)

P3 makes at 10° . (9A)

Escape interlock relays 131 and wcr_1 picked. (12A)

4. Fourth cycle of operation:

The card is punched.

Manual Duplication (Program Control On)

- **The starwheels are lowered, the machine is in numeric shift, and the dup key starts the operation. (The master card must have a punched hole or no escapement will take place.)**
- **An escapement occurs and each punch cycle is also a read cycle under the control of field definition. Duplication continues to the end of the field.**
- **The first cycle is a dummy punch cycle. The second and third cycles are combination read and punch cycles. In a three-column field, the fourth cycle is a punch cycle only.**

Description

Figure 3-7 shows a block diagram and a sequence chart of manual duplication with program control on.

1. Pressing the dup key picks dup-1 relays 114 and 116.

2. The dup-1 relays hold the keyboard restored and start a dummy punch cycle. During this cycle, dup-2 relays 120 and 122 are picked, and card column 1 is read by the sensing pins.

3. An escapement occurs and a circuit is completed through the 12 or 4 starwheel to continue duplication. This hole in the program card provides a hold circuit for the dup-1 and dup-2 relays.

4. After an escapement, another combination read and punch cycle takes place. During this cycle, column 3 is read and column 2 is punched.

5. Another escapement takes place, and the final punch cycle punches column 3.

Circuit Objectives

Refer to Figure 3-7. Program 1 mode, program control is on, and the first three columns of the program card are punched to designate a manual numeric field.

1. First cycle of operation:

Dup-1 relays are picked through dup keystem contact. (10A)

Dup-1 relays hold the keyboard restored and start a dummy punch cycle.

During this cycle, the dup-2 relays are picked and card column 1 is read by the sensing pins. (10A)

An escapement occurs and, as the program card moves into column 2, the starwheel falls into the 12-hole in the program card. The 12-starwheel contact provides a hold circuit for dup-1 and dup-2 relays.

2. Second cycle of operation:

With dup-2 relays held during the second cycle, the card at the read station is read in column 2, and the card at the punch station is punched in column 1.

The keyboard restore has a continuous hold through the dup-1 relay (114-1).

The escape magnet is energized at 180° by the interposer bail contacts.

The master card moves to column 3, and the detail card moves to column 2.

The program drum moves to column 3, and the starwheel is still in a 12-hole in the program card.

3. Third cycle of operation:

The 12-starwheel contact holds the dup-1 and dup-2 relays.

The card at the read station is read in column 3, and the card at the punch station is punched in column 2.

The escape magnet is energized at 180° .

The master card moves to column 4, and the detail card moves to column 3.

The program drum moves to column 4, which causes the 12-starwheel contact to break and open the circuit to dup-1 and dup-2 relays.

4. Fourth cycle of operation:

The dup-1 and dup-2 relays drop at 355° .

The card will *not* be read (120-1), and a new punch cycle will *not* be initiated.

The card at the punch station is punched in column 3.

Automatic Duplication

- **The auto skip/auto dup switch must be on.**
- **Automatic duplication is initiated by sensing a 0-hole in the program card in program 1 mode, or a 6-hole in program 2 mode.**

Description

The only difference between manual dup, program control on, and auto dup is the way each operation is

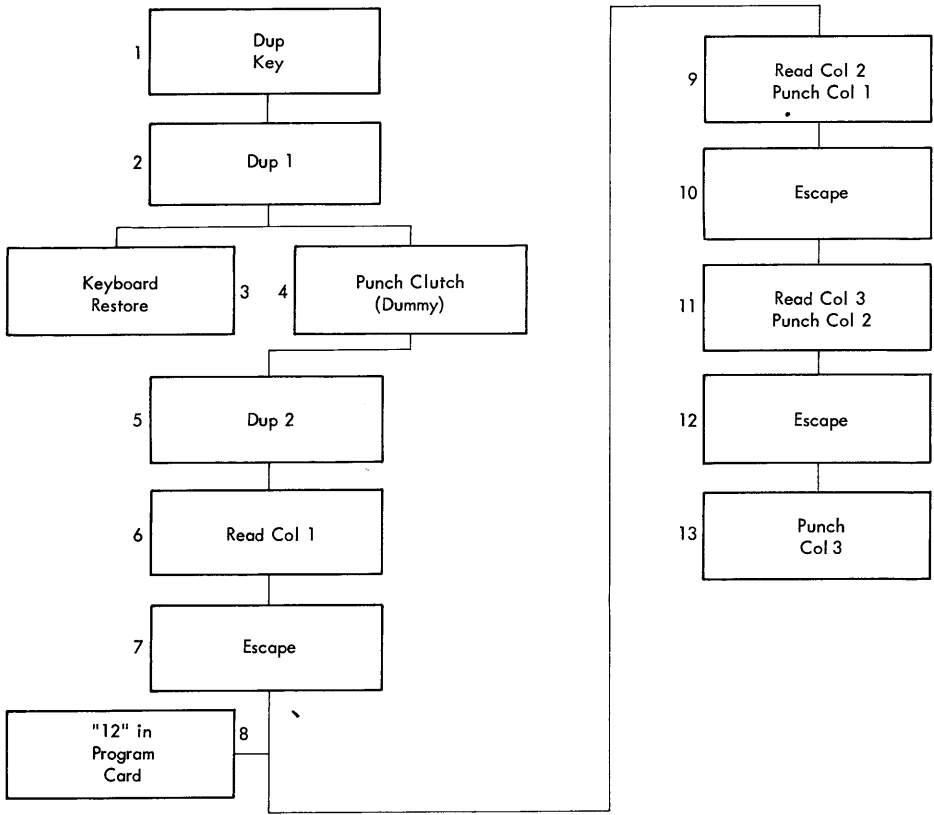

BLOCK DIAGRAM

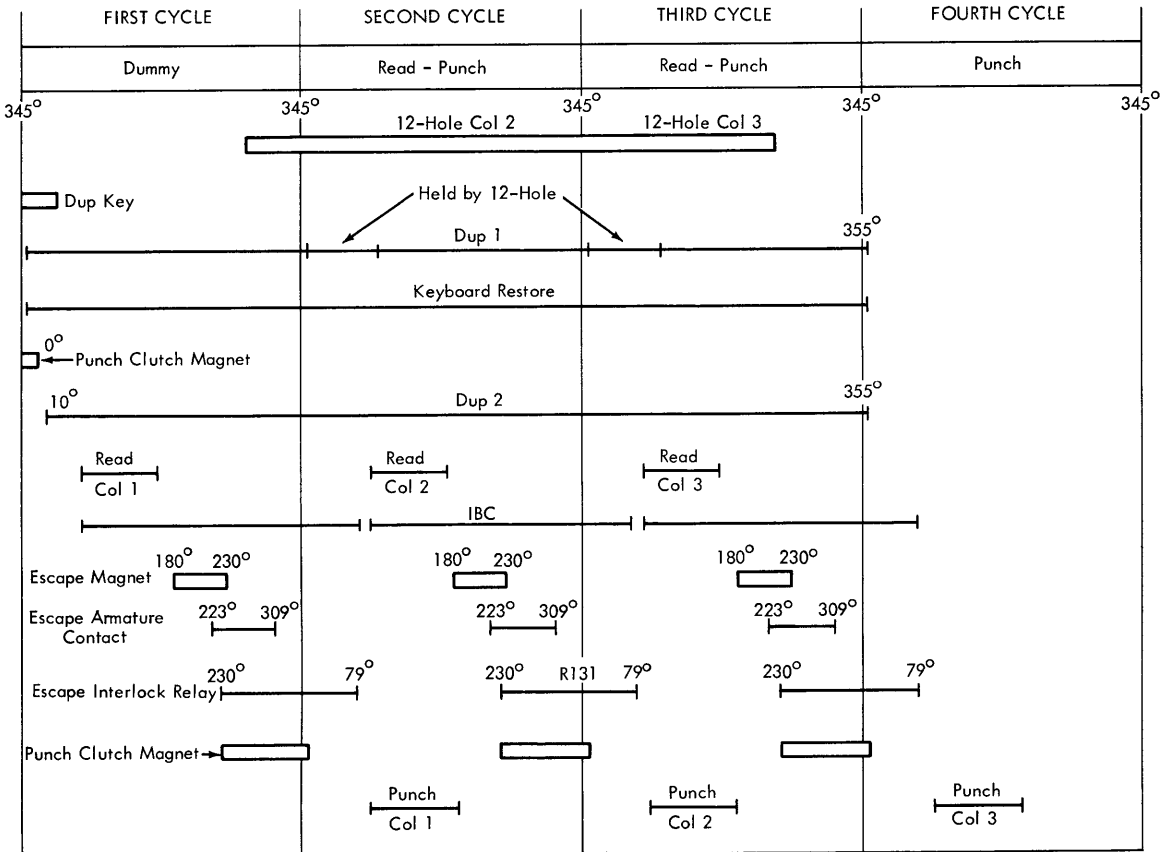

SEQUENCE CHART

Figure 3-7. Manual Duplication (Program Control On)

started. The first cycle is a dummy punch cycle to read the hole in the first column of the field in the master card. The machine then escapes one column and takes another punch clutch cycle to punch the character that was read in column 1. During this second punch cycle the machine also reads the second column of the field. The sequence of reading one column, punching the previous column, and escaping, continues until the end of field definition.

The machine is normally in numeric shift, because the starwheels are down, and will lock up on a blank column unless placed in alpha shift.

Circuit Objectives

Refer to Figure 3-8. Read a zero (program 1 mode) in the program card, take a read cycle, and escape one column.

1. First cycle of operation:
 - a. Pick dup-1 relays.
Zero (dup) program sensing contacts.
 - b. Hold dup-1 relays.
116-4.
A parallel path: P4 (M175°-B355°) to +48 volt card lever, or I31-4 N/C, 112-6 to +48 volt backspace.
 - c. Energize the keyboard restore magnets.
114-1.
 - d. Energize punch clutch for dummy punch cycle.
116-2.
 - e. Pick dup-2 relays at 10°.
116-1.
P3 (M10°-B60°).
 - f. Hold dup-2 relays.
122-4.
0-starwheel contact.
 - g. Read first column of master card.
120-1.
P5 (M86°-B166°).
 - h. Energize escape magnet.
Interposer bail contacts.
 - i. 12-starwheel contact makes, 0-starwheel contact breaks.
Program drum moves from column 1 to column 2.
 - j. Hold dup-1 and dup-2 relays.
P4 (between 0-starwheel break and 12-starwheel make).
12-starwheel contact.
 - k. Energize punch clutch magnet.
2. Second, third, and fourth cycle of operations:
 - a. The 12-starwheel contact holds the dup-1 and dup-2 relays, and continues duplication.

- b. A combination read-and-punch cycle is initiated as a result of the 12-starwheel holding dup-1 and dup-2 relays.
- c. During the second cycle of operation, column 2 is read and column 1 is punched.
- d. After an escapement, another combination read-and-punch cycle takes place.
- e. During the third cycle of operation, column 3 is read and column 2 is punched.
- f. Another escapement occurs, field definition is lost (no 12-hole in column 4 of the program card), and the final punch cycle punches in column 3.

Skipping

- Cards can be skipped by two methods:

1. Manual skip (with or without program control).
2. Automatic skip (under program control).

With program control off, pressing the skip key results in the card punch taking a single space. With program control on, the skip key initiates the escapement, and the field definition punches continue the skip to the end of the field. With a blank program card, pressing the skip key results in the card punch taking a single space.

Sensing an 11-punch (program 1 mode) or 5-punch (program 2 mode) initiates a skip automatically. The field definition in the remaining columns continue the skip through the rest of the field. This is an auto skip field. The auto skip operation is made active by lowering the starwheels and turning on the auto skip/auto dup switch.

Manual Skip – Program Control Off

- Each skip key depression causes a single column escapement and a punch cycle.

Description

Pressing the skip key closes the skip key latch contact and energizes the escape magnet. The escape magnet causes an escapement and closes the escape armature contact, which picks the escape interlock relay and the skip relay. The escape interlock relay (WCR1) drops out the escape magnet and energizes the punch clutch magnet.

The punch clutch magnet starts a punch cycle. The keyboard is restored through points of the skip relay.

Circuit Objectives

1. Energize escape magnet. (10B)
Skip key latch contact.

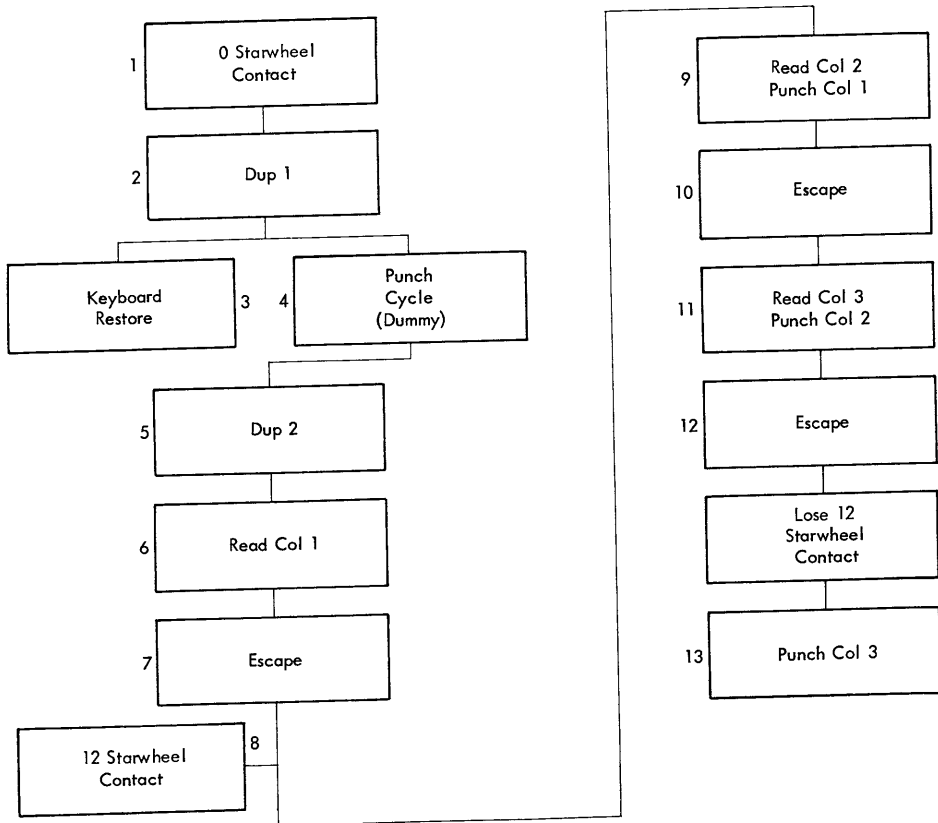

BLOCK DIAGRAM

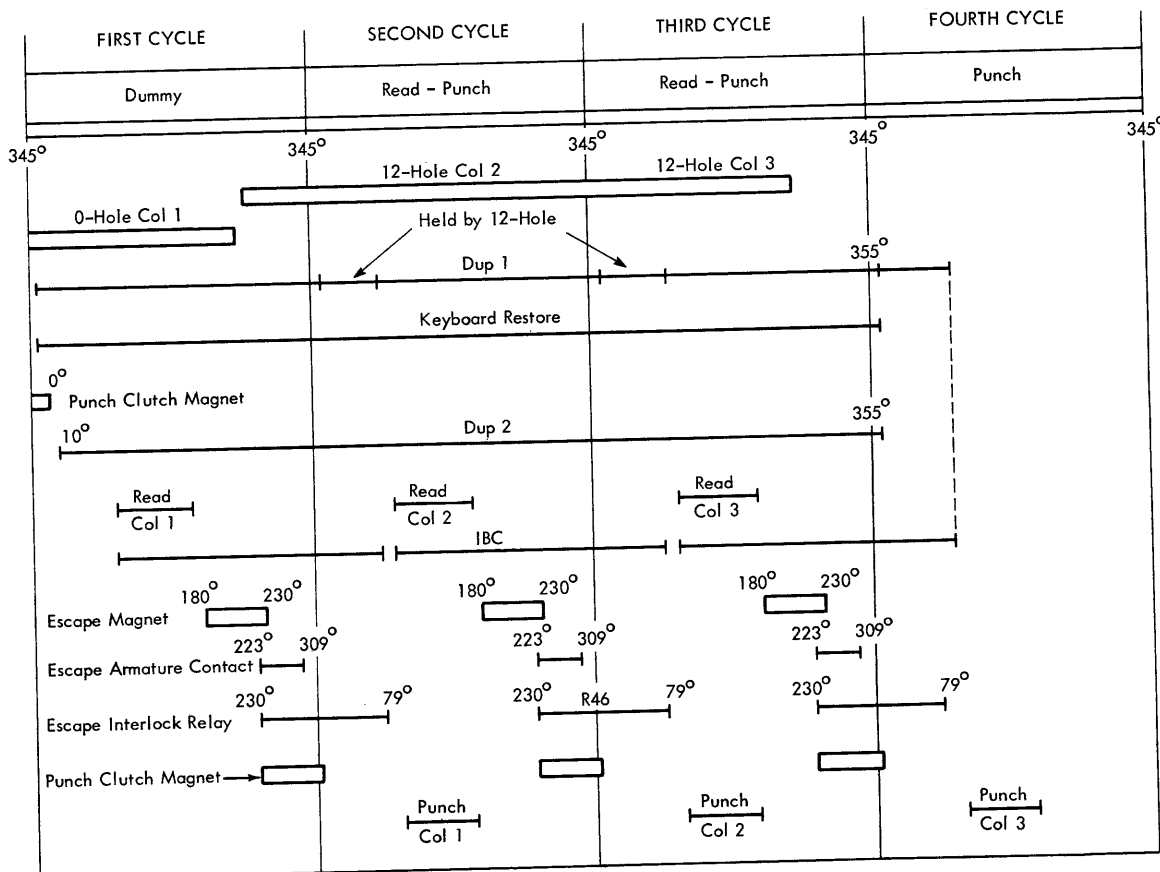

SEQUENCE CHART

Figure 3-8. Automatic Duplication

2. Pick escape interlock relays 131 and WCR1. (12A)
Escape armature contact. (11A)
3. Pick skip relays 117 and 123. (10A, 10B)
131-6. (10B)
4. Energize keyboard restore magnets. (8A)
117-1 (7A)
5. Energize punch clutch magnet. (12A)
WCR1-4. (12A)

Manual Skip — Program Control On

- **Press the skip key to initiate the operation. The 12-holes in program 1 mode (4-holes in program 2 mode) continue the operation.**
- **The major objectives of a skip key operation are:**
 1. **Hold the keyboard restored.**
 2. **Cause an escapement.**
 3. **Energize the punch clutch magnet for one cycle.**
 4. **Hold the skip relay.**
 5. **Energize the escape magnet under control of the 12-program contact.**

Description

During a manual skip operation when there is field definition in the program card, pressing the skip key causes the machine to escape one column, execute a punch clutch cycle, and then skip the remainder of the field.

The skip key picks the escape magnet, and a punch cycle takes place. During the punch clutch cycle, the skip relay picks. Because this is to be an automatic skip operation, the 12-holes provide a hold circuit for the skip relay, which in turn moves the card by energizing the escape magnet.

NOTE: Pressing the skip key with program control on and a *blank card* on the program drum causes an escapement and a punch clutch cycle. The card moves only one column because there is no hold circuit for the skip relays.

Circuit Objectives (with Field Definition)

1. Energize escape magnet. (10B)
Skip key latch contact.
2. Pick escape interlock relays 131 and WCR1. (12A)
Escape armature contact. (11A)
3. Pick skip relays 117 and 123. (10A, 10B)
131-6. (10B)
4. Energize keyboard restore magnets. (8A)
117-1. (7A)
5. Energize punch clutch magnet. (12A)
WCR1-4. (12A)
6. Hold skip relays and escape magnet.
12-starwheel contact makes.

7. Drop skip relays and escape magnet.
12-starwheel contact breaks.

Automatic Skipping

- **Automatic skipping is performed with the starwheels lowered and the auto skip/auto dup switch on.**
- **It is started by sensing an 11-hole in program 1 mode or a 5-hole in program 2 mode.**
- **It is continued and finished by the field definition punches (12-hole in program 1 mode, 4-hole in program 2 mode).**
- **The objectives of the operation are:**
 1. **Sense an 11-hole in the program card.**
 2. **Keep the keyboard restored.**
 3. **Escape one column and place the skip circuits under field definition control.**
 4. **Skip the remainder of the field.**

The auto skip/auto dup switch is on, and sensing an 11-hole in the program card (in program 1) energizes the skip relays (Figure 3-9). These relays keep the keyboard restored, prevent energizing the punch clutch, and energize the escape magnet.

Movement of the card opens the 11 program contact and closes the 12 program contact. The 12 contact provides a hold circuit for the skip relay and the escape magnet.

Because the 12-starwheel is not made at the instant the 11-starwheel breaks, a resistor and capacitor is wired in parallel with the skip relay circuit. This resistor-and-capacitor combination delays the drop out time of the skip relays so that the 12-starwheel contact can make and provide a hold for both the skip relays and the escape magnet.

Multipunch (Multiple Punching)

- **Any number of holes can be punched in one column by first pressing the multipunch key, then pressing the desired numeric keys.**
- **One escapement occurs and the punch unit is made operative without the aid of additional escapements as long as the multipunch key is held.**
- **The alpha relay cannot be picked.**

Description

The multipunch (MP) key must be pressed before a character key is pressed. The MP key operates two keystem contacts. The normally open contact is in the circuit to the MP relay, and the normally closed contact is in the alpha relay circuit. The alpha relay is

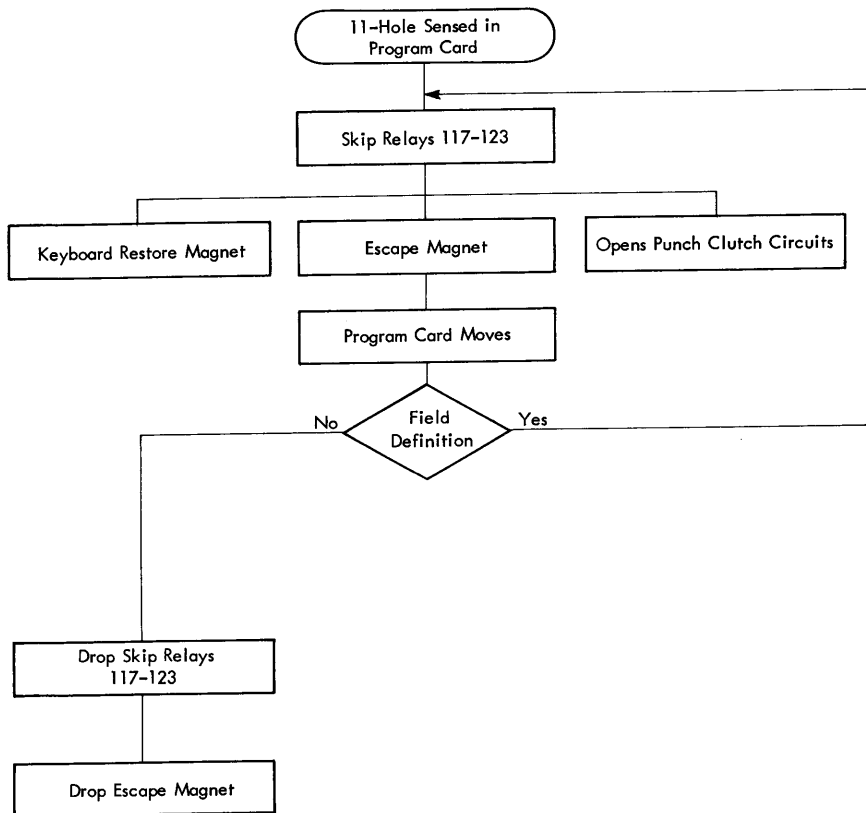

Figure 3-9. Automatic Skip

dropped immediately and remains dropped as long as the MP key is pressed, but the MP relay circuit is first picked by the MP keystem and remains held until the keystem is released.

Upon pressing a character key after first holding the MP key pressed, the machine escapes one column and a punch cycle results. The escapement closes the escape armature contact, picking the MP relay. The MP relay is held by its own points, through the keystem contacts, and opens the escape magnet circuit to prevent further escapement.

Should multiple punching occur in column 80 or in the last column preceding a programmed field (*auto skip* or *auto dup*), multipunch points delay the start of the automatic operation until the MULT PCH is released. They also prevent starting a skip if the skip key is pressed during multiple punching.

Circuit Objectives

Refer to Figure 3-10. Prevent escapements after the first cycle of operation, but allow additional punch cycles without an escapement:

1. First cycle of operation:
 - a. Drop alpha relay. (12B)
MP keystem (N/C). (6A)
 - b. Energize escape magnet. (10B)
Interposer bail contacts.
Interposer magnet energized.
Numeric keystem.
 - c. Pick MP relay. (6A)
MP keystem upper.
Escape armature contact 4.
 - d. Pick escape interlock relays. (12A)
Escape armature contact.
 - e. Punch clutch energized. (12A)
WCR1-4.
2. Second MP cycle:
 - a. Escape magnet circuit is open.
113-5. (10B)
 - b. Energize punch clutch without normal escapement.
113-6. (11A)
12-interposer bail contacts.
Interposer magnet energized.

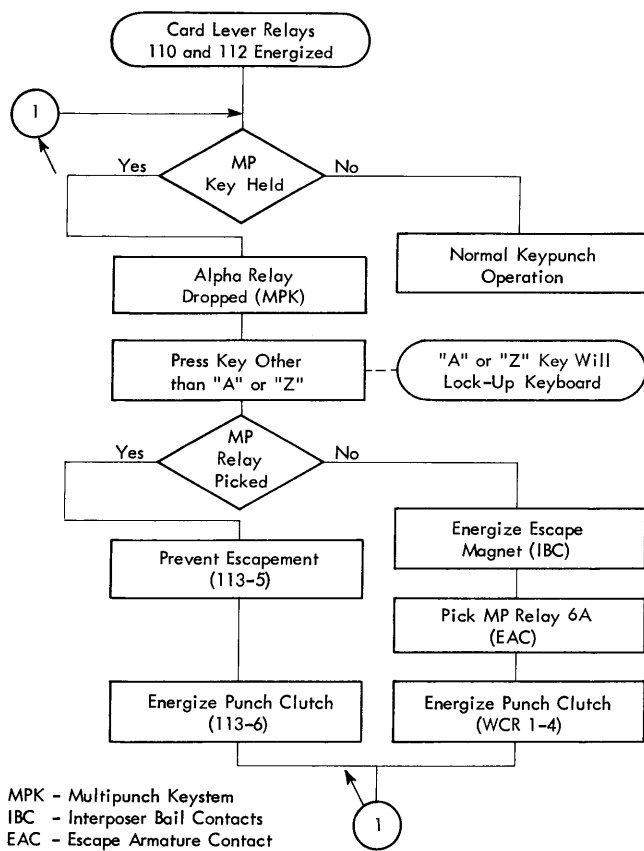

Figure 3-10. Multipunch Operation

Release Key, Not Programmed, with Cards

- Pressing the release key causes the escape mechanism to move.
- The program drum revolves and stops in column 1.
- The keyboard is restored.
- A card is fed from the hopper if the auto feed switch is on.

Description

A card will move through either the punch or read stations if the escape mechanism moves. Pressing the release key picks the release relay, skip relay, escape magnet, and operates the escape mechanism. This chain of events releases the card positioned at the punch or read station. The program drum revolves in synchronism with the card movement through the punch or read station.

The release relay is picked directly through the release key latch contact and +48 volts. Both the release and card lever relays hold under control of PCC2 N/C (program cam contact 2) until the program drum has gone past column 82½ to 84. The release and card lever relays share the same hold circuit.

The release relay points complete a circuit to pick the skip relay. Picking the skip relay energizes the escape magnet.

The escape magnet holds under control of the skip, card lever, and release relays. The program drum must get back to column 1. The release circuit, which holds the skip relay and escape magnet, opens when the release relay point transfers as the program drum moves past column 82½ to 84. Therefore, to get the drum into column 1, the skip relay and escape magnet are held by another circuit.

Both the skip relay and escape magnet hold under control of program cam contact 1 (PCC1) until column 88½ on the column indicator. When the program drum moves past column 88½, both the skip relay and escape magnet drop, and the program drum stops in column 1. With the auto feed switch on, the card punch automatically goes through a card feed cycle as the program drum moves from column 80 back to column 1.

Pressing the release key restores the keyboard. There is an alternate path for restoring the keyboard at this time. The circuit is through a skip relay point and is used on an automatic skip operation when the release key is not pressed.

The keyboard is held restored during an entire skip or release operation. Therefore, no other character key can be pressed while the escape mechanism is moving.

Circuit Objectives

1. Pick release relay 121. (6B)
Release latch contact N/O.
2. Hold release relay 121. (6B)
121-2 N/O.
3. Hold card lever relays 110 and 112. (8B)
112-1 N/O. (7B)
PCC2 (N/C column 82½ to 84). (5A)
4. Skip relays picked and held 117 and 123. (10A, 10B)
Program handle 1 raised. (9B)
121-6 N/O. (9B)
5. Energize escape magnet. (10B)
123-6 N/O. (9B)
Program handle switch 1 raised. (9B)
121-6 N/O. (9B)
6. Hold skip relays and the escape magnet to get the program drum into column 1:
PCC1 N/O (M column 80½ to 80% - B column 88½). (9B)
7. Restore the keyboard.
Keyboard restore magnets. (8A)
121-5 N/O and 117-1 N/O. (7B)

8. a. Feed a card:
PCC2. (5A)
Auto feed switch on. (6A)
- b. With the auto feed switch off, the card does not register at the next station, and there is no card feed cycle.

Release Key, without Cards

- Release *without* cards is identical to release *with* cards except the circuit to pick the skip relay and escape magnet is different.

1. Without cards in the machine, the card lever relay is normal (not picked).
2. Pressing the release key energizes release relay 121. (6B)
3. The release relay picks the skip relay through card lever 112-3 N/C and 121-6 N/O. (9B)
4. The escape magnet is energized through skip relay 123-6 N/O and 121-6 N/O. (9B)
5. The release circuits are controlled through program cam contact 2 until columns 82½ to 84.
6. The pick circuits for the skip relay and escape magnet are controlled through 112-3 N/C.
7. On a release operation, the keyboard is restored through release relay 121-5 N/O and skip relay 117-1 N/O points in parallel. (7B)

Release — Program Control On, with Cards

- Press the release key with program control on, and the card lever relays picked, to cause all the programmed operations to occur.
- During the release operation:
 1. A blank field causes auto spacing.
 2. A manual field causes a smooth release or skip.
 3. An auto skip or auto dup field causes the programmed operation to be performed.

Description

The type of field in the program card causes one of four conditions when the release key is pressed with program control on. The starwheels can sense a blank program card, a manual field containing only 12's, an auto skip field, or an auto dup field.

When the release key is pressed, the cards release. A blank field in the program card causes the machine to space or auto space continuously. A manual field, having field definition, causes a smooth release or skip. An auto skip field causes an auto skip operation, and

an auto dup field causes the machine to go into an auto dup operation.

Release Key — Blank Field

- The release key operation in a blank field in the program card alternately energizes the escape magnet and then the punch clutch magnet.

Circuit Objectives

Refer to Figure 3-11.

1. Pick release relay. (6B)
Release key latch contact.
Holds through PCC2 N/C. (5A)
2. Energize escape magnet. (10B)
121-6 N/O. (9B)
3. Pick escape interlock relays. (12A)
Escape armature contact.
4. Energize punch clutch. (12A)
WCR1-4.
5. Drop escape magnet (stops escapement). (10B)
WCR1-1
6. During the punch cycle, the escape interlock relays drop, the release relay is still held energized through PCC2 N/C. As soon as the escape interlock relays drop, the escape magnet is re-energized and the sequence of events (steps 1-5) is repeated.

Release Key — Manual Field

- The release key operation in a manual field (12's or 4's) in the program card results in a smooth skip through the entire field.

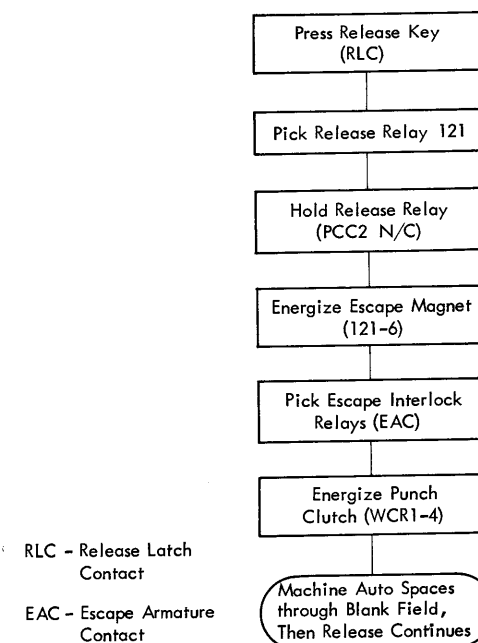

Figure 3-11. Release Key Operation (Blank Field)

Circuit Objectives

Refer to Figure 3-12.

1. Pick release relay (causes card movement). (6B)
Release key latch contact.
Holds through PCC2 N/C. (5A)
2. Pick skip relays. (10A, 10B)
121-1. (10B)
Program starwheel contacts 12 or 4.
3. No punch clutch or escape interlock relay circuit.
123-5. (11A)
4. Energize escape magnet. (10B)
123-6 and 123-1.
Hold through program starwheel contacts 12 or 4.

Release Key – Auto Skip Field

- The release key operation in an auto skip field (11 or 5 in the program card) with the auto skip/auto dup switch on, results in auto skipping the entire field.

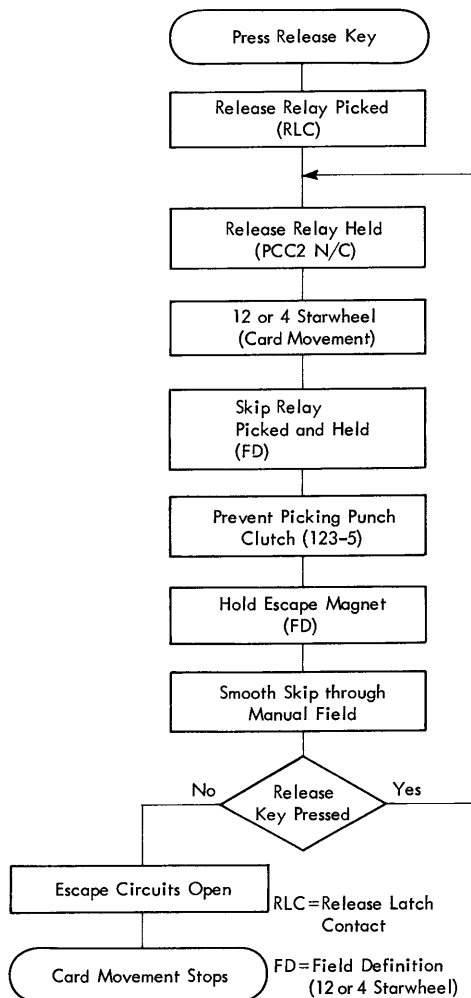

Figure 3-12. Release Key Operation (Manual Field)

Circuit Objectives

Refer to Figure 3-13.

1. Pick release relay (causes card movement). (6B)
Release key latch contact.
Holds through PCC2 N/C. (5A)
2. Pick skip relay. (10A, 10B)
121-1. (10B)
Auto skip/auto dup switch on. (9A, 9B)
Program starwheel contacts 11 or 5.
3. No punch clutch or escape interlock relay circuit.
123-5. (11A)
4. Energize escape magnet. (10B)
123-6 and 123-1.
Program starwheel contacts 11 or 5.
Holds through program starwheel contacts 12 or 4.

Release Key – Auto Dup Field

- The release key operation in an auto dup field (0 or 6 in the program card), with the auto skip/auto dup switch on, results in automatic duplicating the entire field.

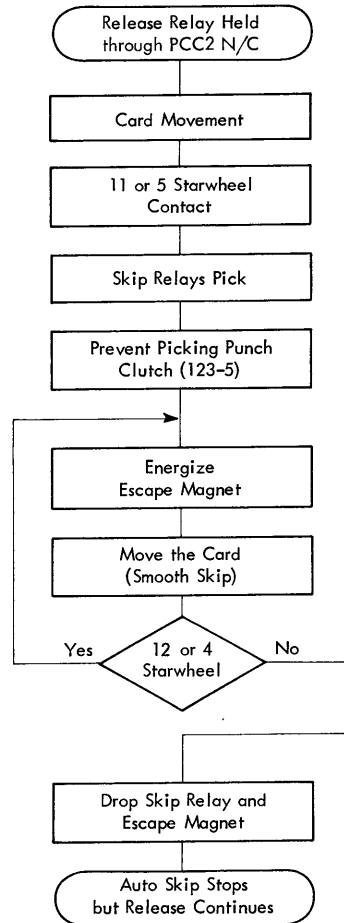

Figure 3-13. Release Key Operation (Auto Skip Field)

Circuit Objectives

Refer to Figure 3-14.

1. Pick release relay (causes card movement). (6B)
Release key latch contact.
Holds through PCC2. (5A)
2. Auto skip/auto dup switch on. (9A, 9B)
3. Dup-1 relays picked. (10A)
0 or 6 program starwheel contacts.
4. Release circuit to escape magnet is open.
114-2. (9B)
5. Auto dup starts under control of the 0- or 6-hole in the program card and continues under control of field definition (12- or 4-hole).

Clear

- The clear operation moves cards from the detail and master stations into the stacker without feeding cards from the hopper.
- The clear switch is a spring-loaded momentary contact switch, that, when operated, initiates the multiple cycles required to clear the card transport area.

Description

Refer to Figures 3-15, 3-16, and 3-17. Pressing the clear switch picks clear 1 relay, which is held through its own point, CF2, or read card lever. The MP relay will pick and hold through clear 1 and PCC2. The MP

relay will repick as long as the clear 1 relay is up when PCC2 is made. The MP relay is picked to make the starwheels inoperative. Because clear 1 is up, the skip relays will be picked through CF2, clear 1, and clear 2. Escapement will occur. Clear 2 relay is picked when PCC2 transfers at column 82½ to 84. This allows the end of the card-to-card skip to be under control of PCC1.

The transfer of PCC2 also energizes the card feed latch magnet through clear 1, causing a card feed cycle. During the CF (card feed) cycle, the machine samples for read card lever. Read card lever being made between 180° and 355° will not permit the clear 1 relay to drop out (Figure 3-16). Under this condition, escapement begins at 355°.

This operation continues until the read card lever is open during 180° to 355° of the CF cycle. The clear-1 relay drops out and the machine stops in column 1.

Circuit Objectives

Refer to Figure 3-17. With a card in the detail station:

1. Pick clear-1 relay 107. (6B)
Clear switch. (5B)
2. Hold clear-1 relay 107.
107-1.
Read card lever or CF2.
3. Pick MP relay 113. (6A)
Clear switch. (5B)
4. Hold MP relay 113.
107-2. (6A)
PCC2. (5A)
5. Starwheel control circuits broken.
MP point 113-4. (11B)
6. Pick skip relays 117 and 123. (10A, 10B)
107-6. (6B)
CF2. (5B)
7. Energize escape magnet. (10B)
107-6.
CF2.
8. Pick clear-2 relay 108. (6A)
PCC2 breaks at column 82½ to 84. (5A)
9. Cause a card feed cycle.
Energize CF latch magnet. (6A)
107-5 (5A)
PCC2.
10. Clear operation ends.
Drop clear-1 relay 107. (6B)
Read card lever open during 180° to 355°. (5B)

Printing Control

- No printing occurs when the print suppress magnet is energized.
- The print suppress magnet is energized when:
 1. The print switch is off.

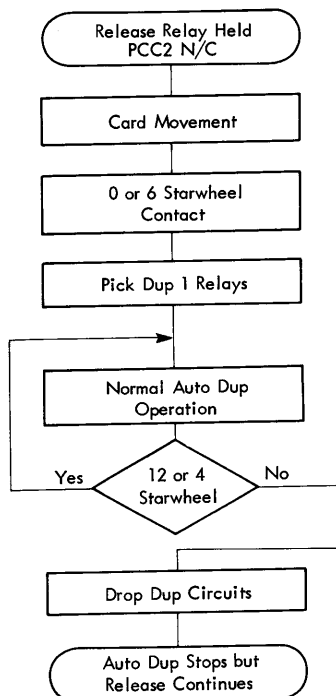

Figure 3-14. Release Key Operation (Auto Dup Field)

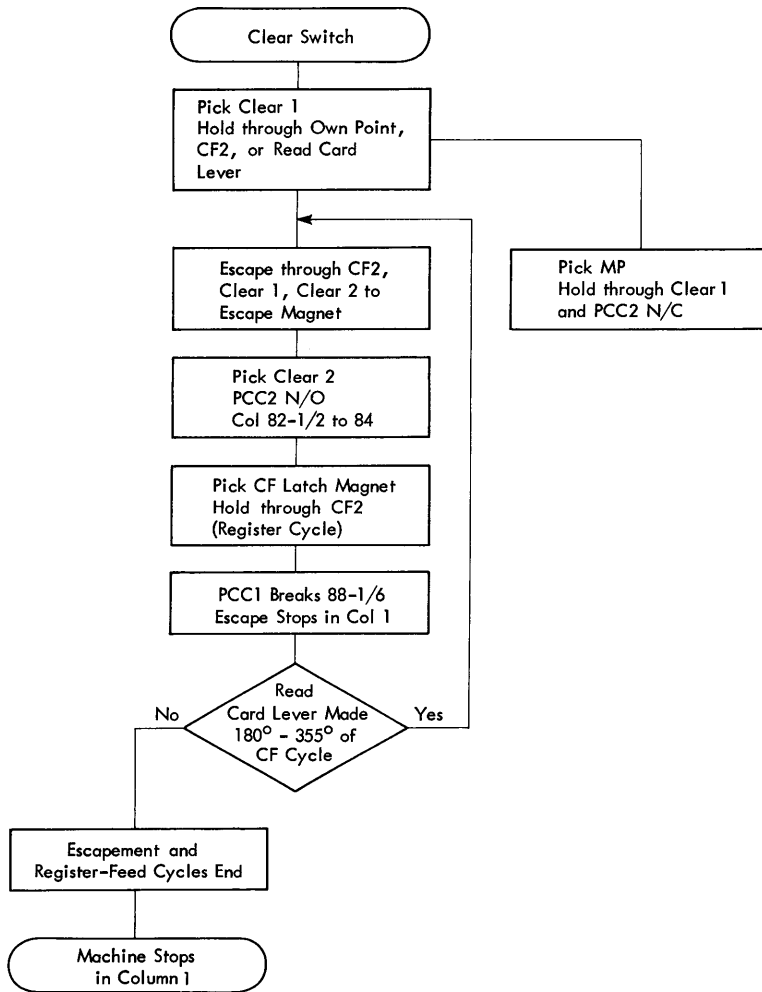

Figure 3-15. Clear Operation

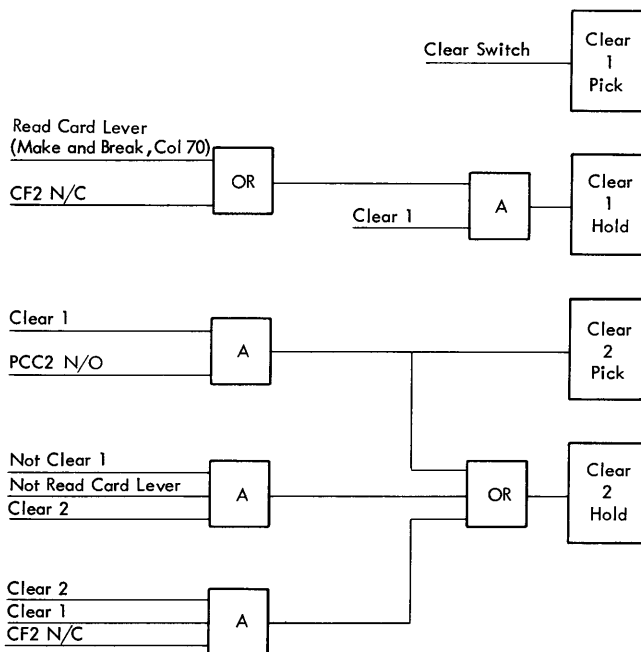

Figure 3-16. Clear 1 and Clear 2 – Pick and Hold

- The print relay is not picked, program control is on, and field definition (a 12- or 4-hole) is read by the starwheel contacts.

Description

The print suppress magnet is controlled by two circuits: one through the print switch, and one from field definition (12 or 4 starwheels) through a print relay point.

With the print switch off, printing is unconditionally suppressed. With the print switch off, +48 volts is supplied the print suppress magnet directly.

With the print switch on and the left-zero print switch in the OFF position, printing of zeros to the left of the first significant digit of a field is suppressed.

Left-Zero Print

- Left-zero printing is controlled by the left-zero print switch on the keyboard switch panel.
- The print switch must be on.

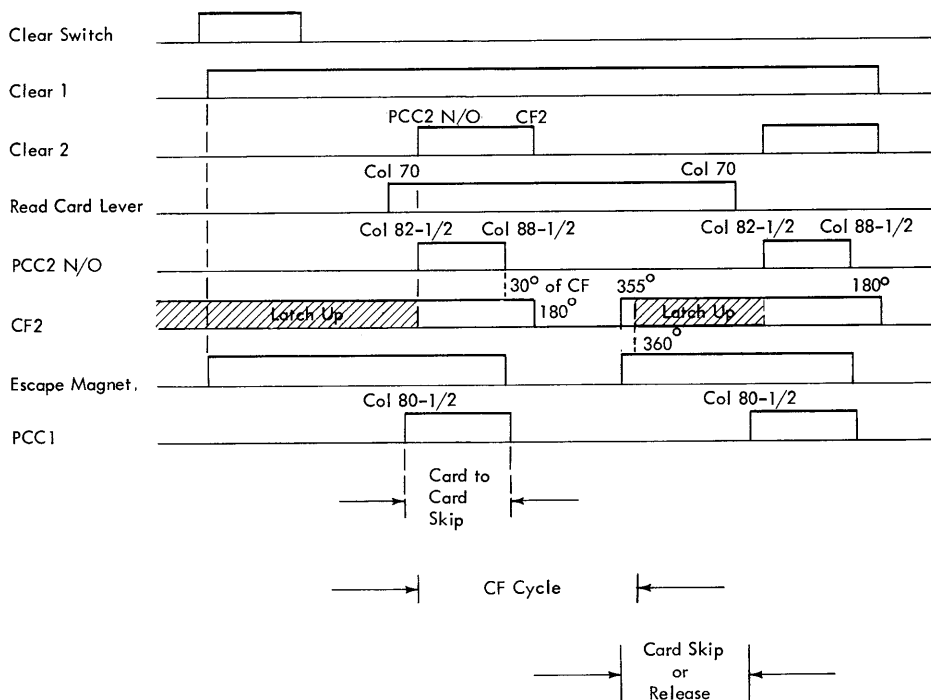

Figure 3-17. Clear Operation (With Card in Detail Station)

- **With the left-zero print switch on, and the starwheels lowered, all zeros print.**
- **With the left-zero print switch off, and the starwheels lowered, printing of zeros to the left of the first significant digit of a field is suppressed.**
- **The units position of the field always prints.**
- **When the machine is unprogrammed or when it is in a field of blank columns in the program card, all columns print.**
- **Zeros always print if the starwheels are raised.**

Description

With the print switch turned on and program control on, the print relay controls the operation of the print suppress magnet. With the print relay picked, the circuit from the field definition starwheels (12 and 4) to the print suppress magnet is open. Under this condition, all characters punched in a card are printed.

The print relay can only be picked when the interposers sense a significant digit or when the left-zero print switch is in the ON position. The hold circuits for the print relay are through its own points to P4 and 111-4 to the field definition starwheels (12 and 4).

With the left-zero print switch off and the machine under program control, the print relay remains normal until a significant digit is sensed. Once the print relay is picked, it holds through P4 as long as there are 12- or 4-holes in the program card.

During an auto dup operation, all zeros to the left of a significant digit will not print. There is no circuit from the zero sense pin to pick the print relay and break the circuit to the print suppress magnet from the field definition starwheels. Therefore, to print zeros in an auto dup operation, the print relay must be picked to prevent the 12 or 4 starwheels from energizing the print suppress magnet. The field definition punches suppress zero printing when the print relay is down and also hold the print relay up to prevent print suppression.

Alphabetic and other characters having a 0-punch print regardless of the setting of the left-zero print switch. The significant digit associated with the punched code for the character, picks the print relay and prevents energizing the print suppress magnet.

Zeros keyed from the keyboard are prevented from printing only when the machine is under program control and with field definition.

When in a manual numeric field and the entire field is punched with zeros, only the last zero in the field will be printed. The printing of the zero in the last column of the field is not suppressed, because the 12- or 4-hole in the program card is not made at print time. Before the key is pressed for this column, the program drum is in the column beyond the card registered at the punch station (program card in column 55, card at punch station in column 54). The zero key is pressed, an escapement occurs, and the 12 starwheel

contact opens. The program drum stops in column 56, and the card at the punch station stops in column 55. The punch unit operates at the same time. This zero does print because there is no 12-hole in column 56 of the program card to energize the print suppress magnet. The fact that a zero prints in the units position of a field when the left-zero print switch is off, indicates that a significant digit has not been punched ahead of this zero.

Circuit Objectives

1. Suppress all printing:
 - Energize print suppress magnet. (14B)
 - Print switch off. (13B)
2. Suppress printing of zeros until a significant digit is punched. (The machine is under program control and the left-zero print switch is off):
 - Energize print suppress magnet. (14B)
 - 12 or 4 starwheel contact.
3. Print the first significant digit after zeros, print all other characters, and print all zeros to the right of significant digits. (The left-zero print switch is off.):
 - Drop the print suppress magnet. (14B)
 - Pick print relay 111. (14A)
 - Digit pin sense contact.
 - Hold print relay.
 - P4. (9A)
 - 12 or 4 starwheel contact.

Wire Contact Relay Machines

Manual Punching Operation

- The objectives of manual punching are:
 1. Press a character key.
 2. Escape one column.
 3. Punch the card.
 4. Restore the keyboard.

Description

To punch a card manually in column 1, a card must be registered at the punch station in column 0. With a card registered in the punch station, the card lever relay is picked and holding.

The interposer magnets can be energized from the keyboard during manual punching. Whenever an interposer magnet is energized, the corresponding punch interposer unlatches, and the two interposer bail contacts close in parallel. When the interposer bail contacts close, the escape magnet is energized.

The objectives of manual punching, as stated above, can be illustrated by a logic flow diagram. Figure 3-18 shows the manual punch operation. This diagram shows that pressing the key causes the machine to

escape and then punch. Pressing the key also causes the keyboard to restore. Figure 3-1 shows all the mechanical and electrical components in the manual punch operation and how one component can cause one or more functions.

Circuit Objectives

Refer to Figure 3-18:

1. Machine escapes one space:
 - Interposer bail contacts.
 - Energize escape magnet.
2. Escapement held to one column:
 - Escape armature contact.
 - Escape interlock relays (N/C point).
 - Drop escape magnet (after one space).
3. Keyboard is restored:
 - Interposer bail contacts.
 - Energize keyboard restore magnets.
4. Punch a hole in card:
 - P2 (M135°-B65°)
 - Escape interlock relays.
 - Energize punch clutch magnet.

Program Levels (Program 1 and Program 2)

- The upper half of the program card is used for coding Program 1 automatic operations.
- The lower half of the program card is used for coding Program 2 automatic operations.

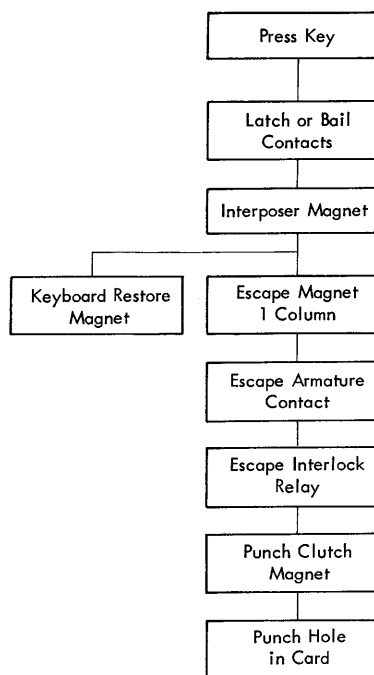

Figure 3-18. Manual Card Punch Operation

Description

The program selection switch (PROG SEL) has two positions, identified as ONE (Program 1) and TWO (Program 2). The setting of this switch determines the program mode that the machine will return to as the column indicator advances from column 80 to column 1. With this switch, the operator can select programming mode 1 or programming mode 2 for each card.

The PROG ONE (program 1) key and the PROG TWO (program 2) key operate in conjunction with the program selection switch. These two keys have two different operations, depending on where in the cycle they are pressed. If a program key is pressed in column 1 or any succeeding column, the machine is shifted to that program mode for the duration of the card, or until the other program key is pressed. By using these keys, it is possible to change from program 1 to program 2 and vice versa anywhere within the card. The program keys also operate in conjunction with the automatic feed switch. If the automatic feed switch is turned off, while the card is processed to column 80, the column indicator advances to column 1. However, an automatic feed cycle is not initiated. In this situation, pressing either program 1 key or program 2 key initiates a feed cycle and sets the machine to the corresponding mode.

The program select relays must have an approximate +48 voltage potential applied for them to pick and hold. When the program 1 relay is picked, the machine is in program 1 mode; when the program 2 relay is picked, the machine is in program 2 mode.

In program 1 mode, the upper half of the program card is read; the lower half of the program card is read in program 2 mode.

If the auto feed switch is on and column 80 of a card is punched, a normal feed cycle takes place and the program mode reverts automatically to the position of the program select switch. This is accomplished by routing the circuit from PCC2 N/O through the auto feed switch ON, and through the program select switch, to both the CF clutch magnet and the program 1 and 2 relays. The program select switch in either program 1 or program 2 position has a parallel path to the CF clutch magnet to provide for an auto feed cycle. The program select switch on a manual feed or auto feed cycle also controls the pick or drop of the program 1 and 2 relays.

If the auto feed switch is off and column 80 of a card is punched, the card in the punch station is released to the master station and the card in the detail station is not registered. This is a normal operation (card-to-card skip) with the auto feed switch off. There is a card at the master station ready to be registered in the read station, and there is a card in the detail station ready to be registered at the punch station.

Under these conditions, pressing the program 2 key causes:

1. The program 2 relay picks.
2. The CF clutch magnet is energized.
3. The card in the master station is registered in the read station.
4. The detail card is registered in the punch station.
5. A card is fed from hopper to detail station.

The machine is ready for further operations in program 2 mode, because the program 2 relay is picked.

If the program 1 key is pressed under the previous conditions with the auto feed switch off, the program 1 relay will have +48 volts applied and will be picked.

Steps 2-5 are the same as when pressing the program 2 key, but the machine will be in program 1 mode.

Figure 3-19 shows the basic logic flow of program 1 and 2 selection. Figure 3-20 is a second level (AND-OR) logic of the program selection operation.

Circuit Objectives

Program 1: To allow program control from upper half of the program card (see wiring diagrams):

1. Pick program 1 relay 13. (6A)
Program 1 key.

Program 2: To shift the program control from the upper half of the program card to the lower half:

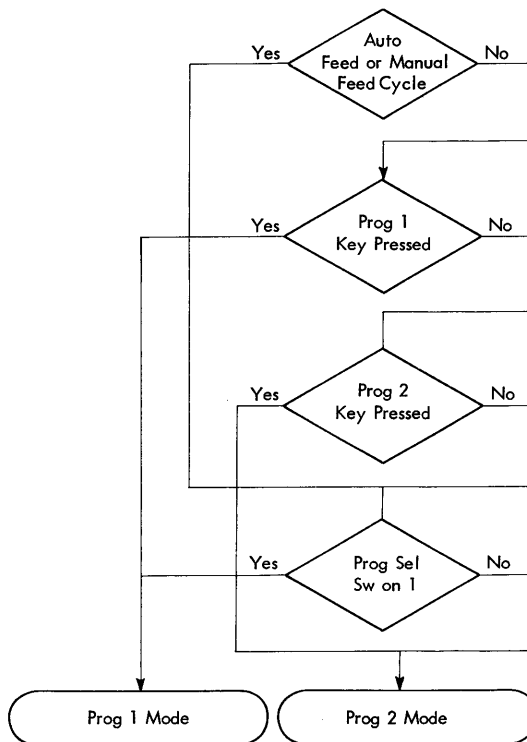

Figure 3-19. Program Selection

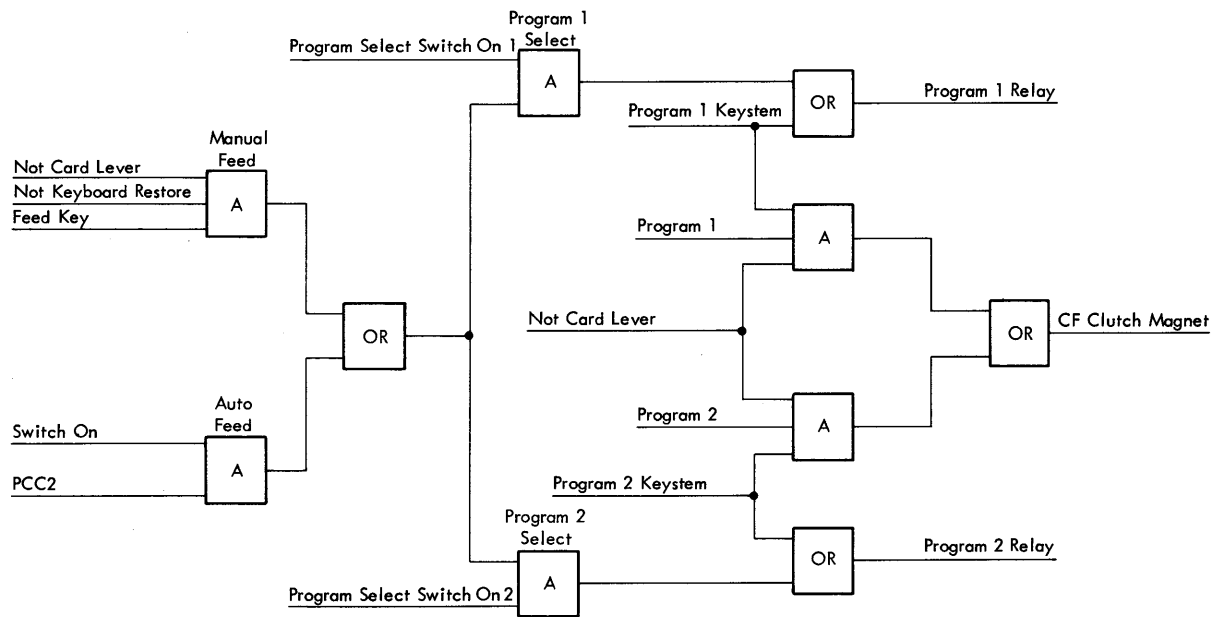

Figure 3-20. Program Selection

1. Pick program 2 relay 14. (6A)
Program 2 key. (5A)
Hold through 14-1 N/O. (6B)

2. Read (sense) only lower half of program card.
Relay 14 points transferred; relay 13 points N/c.

End of Card – Auto Feed Switch On: To return the program mode to the position of the program select switch during an auto feed cycle:

1. Energize CF clutch magnet. (6A)
Stacker switch N/c. (6A)
Card lever 24-3 N/c. (6A)
Program select switch on 2. (5A)
Auto feed switch on. (5A)
PCC2 N/O. (5A)
2. Pick program 2 relay 14. (6A)
From PCC2 N/O and prog sel sw 2. (5A)
3. Hold program 2 relay 14. (6B)
14-1 to +48 volts. (6B)

End of Card – Auto Feed Switch Off: Advance column indicator to column 1 and prevent CF cycle:

1. Normal card to card skip:
PCC1. (11A)
2. Prevent CF cycle:
PCC2 circuit open. (5A)
Auto feed switch off. (5A)

Initiate feed cycle:

1. Energize CF clutch magnet. (6A)
Stacker switch N/c. (6A)
Card lever N/c. (6A)
Program 2 key. (5A)

Set machine to program 2 mode:

1. Pick program 2 relay 14. (6A)
Program 2 key. (5A)
2. Hold program 2 relay 14. (6B)
14-1 to +48 volts. (6B)

Error Reset

The error reset key energizes the keyboard restore magnets. This key has N/O and N/C keystem contact points. Plus 48 volts is supplied the N/C points through the N/C backspace switch to +48 volts at TB2-5 in the power supply. The voltage distribution is shown in the wiring diagram. (20A)

Pressing the error reset key (7A) energizes the keyboard restore magnets through the N/O error reset keystem contact points. (7A)

Feed Key

- The feed key causes cards to feed from the hopper, register at the punch or read stations, and move up into the stacker.
- The feed key (keystem) contact voltage is controlled through N/C card lever relay points.

Pressing the feed key energizes the card feed clutch magnet. This initiates a CF (card feed) cycle, and a card feeds from the hopper to the detail station. Hold-

ing the feed key pressed will initiate a second *CF* cycle, registering the first card in the punch station and feeding a second card to the detail station. Either the feed key or register key will register a card at the punch or read stations, and will cause a card leaving these stations to enter the stacker.

The feed key is operative only when there is no card registered at the punch station. This is because the *N/C* card lever relay points in the *CF* clutch magnet circuit open when the card lever relay is picked. This prevents energizing the *CF* clutch magnet through the feed key keystem contact.

Cards move through the machine as described below:

1. Pressing the feed key twice (or one long depression) executes two *CF* (card feed) cycles and registers a card at the punch station.

2. When the auto feed switch is on and the punching of the first card is completed, the third *CF* cycle is automatic.

3. The third *CF* cycle registers the first card at the read station, registers the second card at the punch station, and feeds a third card from the hopper to the detail station.

4. After punching the second card, the second auto feed cycle occurs.

5. The first card is ejected from the read station and stacked.

6. The second card is registered at the read station, the third card is registered at the punch station, and the fourth card is fed from the hopper to the detail station.

7. In four *CF* cycles the card has moved from the hopper, through the punch station, through the read station, and has been stacked.

The following feed key operation is described as a card is fed from the hopper and registered in the punch station. Two separate (momentary) feed key depressions are described to show two card feed cycles. The same operation also takes place when the feed key is held pressed for two card feed cycles.

Feed Key — First Depression

- **A card is moved from the hopper to the detail station.**
- **Punching is not possible.**
- **The keyboard is restored.**

Description

Pressing the feed key causes a card to move from the hopper to the detail station. Punching and all automatic functions are made operative when the card lever

relays are energized. The card lever relay is energized through the detail card lever contact. As the card moves to the punch station, the action of the card passing between the upper card rail and the pressure rails causes the detail card lever contact to close (make) at 10° of the *CF* cycle. Once the detail card lever is made, the detail card lever contact stays closed as long as there are cards in the punch station.

The circuit to energize the card lever relays is through *CF3* and the detail card lever contact. On the first card feed cycle, *CF3* breaks before the detail card lever contact makes. Therefore, on the first card feed cycle, the card lever relays will not be energized. *N/C* card lever relay points prevent energizing the *CF* clutch magnet after the card lever relays are picked.

Circuit Objectives

1. Feed a card from the hopper to the punch bed on the first momentary depression of the feed key:

- Energize card feed clutch magnet. (6A)

- Feed key contact.

- Card lever contact closes at 5° to 10° of *CF* cycle.

- Card movement.

2. Card lever relay is *not* energized (punching is not active) (8B):

- CF3* breaks (M75°-B285°) before card lever contact makes (10° of the second cycle). (7B)

Feed Key — Second Depression

- **The second card is moved from the hopper to the punch bed.**
- **The first card registers for punching.**
- **Punching and all automatic functions become operative.**
- **Restores the keyboard.**

Description

Pressing the feed key the second time causes the first card to be registered at the punch station and the second card to feed from the hopper. With a card in the punch station, the detail card lever remains closed, and it provides a circuit to the card lever relays from +48 volts through *CF3* (M75°-B285°).

The card lever relay makes punching and all automatic functions operative because its points transfer +48 volts to all these circuits. The card lever relay remains picked under control of the program drum.

The program drum moves in unison with the card. The program cam contacts control the card lever relay hold circuit. Program cam contact 2 *N/C* makes between column 87½ and 88½ on the column indicator, and breaks between column 82½ and 84. This means

that program cam contact 2 N/C point is closed all the time that a card is being processed. The card lever relays hold for a few columns beyond column 80. Program cam contact 2 is timed so that the card lever relays drop out somewhere between columns 82½ and 84.

Feeding a third card is not possible because N/C card lever relay points open the circuit when the card lever relays are holding.

Circuit Objectives

1. Register first card and feed next card from hopper:
Energize card feed clutch magnet. (6A)
Feed key contact.
2. Pick card lever relay 24. (8B)
CF3 (M75°-B285°).
(Detail card lever contact was closed by first card.)
3. Hold card lever relay 24. (8B)
PCC2. (5A)

Card-to-Card Skip (Auto Feed Switch On)

- A card-to-card skip occurs as the program drum moves out of column 80.
- This skip is controlled by the skip relay, escape magnet, and program cam contact 1 (PCC1).
- The circuit to pick and hold the skip relay and escape magnet is through PCC1.
- PCC1 will break at column 88½ and stop the program drum in column 1.
- With the auto feed switch on, the circuit to energize the CF clutch magnet is through PCC2.

The card-to-card skip circuits are established as the drum moves out of column 80. The skip continues until the drum is in column 1. The operation to move the program drum from column 80 to column 1 is similar to a release operation. As the drum moves out of column 80 for any reason, either punching or releasing, the skip relay is energized. It, in turn, picks and holds the escape magnet until column 1 is reached.

When a character key or the release key is pressed, the program drum moves out of column 80. At column 80½ the skip relay is energized through PCC1 (program cam contact 1), which makes at column 80½ to 80¾ and breaks at column 88½. When the skip relay is energized, the escape magnet picks through skip N/O points and uses the same circuit as the skip relay. Both the skip relay and escape magnet hold under control of PCC1 until column 88½.

When the program drum moves past column 88½, both the skip relay and escape magnet drop, and the

program drum stops in column 1. As the program drum moves from column 80 to column 1, a card is fed automatically from the hopper if the auto feed switch is on.

To feed cards automatically, the CF clutch magnet circuit is completed through the auto feed switch in the ON position, from PCC2 normally open side, and +48 volts.

NOTE: The make and break timings of PCC2 (program cam contact 2) refer to the normally closed contact. These timings are reversed for the normally open contact. Shortly after the operating point breaks away from the normally closed contact, it makes on the normally open side. PCC2 makes on the normally open side at column 82½ to column 84, and breaks on the normally open side at column 87½ to column 88½. Therefore, on a card-to-card skip operation with the auto feed switch on, the CF clutch magnet will be energized at column 82½ to 84.

Register Key

- Registers a card at the punch and/or read stations without feeding a card from the hopper.
- Makes punching and all automatic functions operative.
- Restores the keyboard.

Description

The register key performs all the functions of the feed key, but prevents the feeding of cards from the hopper by the action of the card feed latch magnet. Energizing the CF latch magnet causes the CF latch contact to close and supply +48 volts to the CF clutch magnet.

The CF clutch magnet operates the CF mechanism. The mechanical action of the CF latch magnet prevents the feed knives from moving downward, and no cards feed from the hopper. Even though a new card did not feed from the hopper, the card in the punch station closes the detail card lever contact, and the card lever relays pick at about 10° of this CF cycle.

Circuit Objective

1. Energize CF latch magnet (initiates a CF mechanical cycle):
Register key latch contact. (5A)
2. Energize CF clutch magnet (causes CF mechanism to operate):
Card feed latch contact. (6A)
3. Pick card lever relay 24 at 75° of this cycle (8B):
Detail card lever contact (closed from first card).

4. Hold card lever relay 24. (8B)
Card lever relay points 24-1 N/o. (8B)
PCC2 N/c. (5A)
5. Energize keyboard restore magnets:
CF4. (9B)

Backspace Key

- **The backspace key moves any registered card backwards, a column at a time, but not beyond column 1.**
- **The program unit is also backspaced in sequence with the card.**
- **The backspace key restores the keyboard.**
- **Refer to "Functional Units" for detailed mechanical operation.**

Backspacing sequence of operation:

1. Press the backspace key. (7A)
2. The control circuits are opened.
3. The keyboard is restored as the actuating arm transfers the backspace switch.
4. The actuating arm ear allows the cam engaging arm to go under control of the six-lobe cam.
5. Reverse card movement occurs because the cam operated arm pivots and moves the pawl up and down.
6. When the pawl and the ratchet are meshed, the escape mechanism moves in reverse, and backspacing is detented by the escape armature.

Duplication

- **Duplication means sensing the holes in the master card and reproducing them in the detail card.**
- **There are two methods of duplication; manual and automatic.**

Description

Manual duplication is initiated by pressing the dup key without field definition. The punch unit goes through two cycles of operation for each column duplicated.

Automatic duplication is initiated by the starwheels sensing a 0-hole in program 1, or a 6-hole in program 2, in the program card. The punch unit must go through two cycles of operation for the first column duplicated, and one cycle thereafter.

Dummy Punch Clutch Cycle

- **This is the first of two punch clutch cycles. It is used to read the holes in the card at the read**

station, and store this information mechanically in the punch unit.

- **The second punch clutch cycle is used to punch the stored information into the blank card at the punch station.**

Dummy punch clutch cycle is a common term used for the first cycle in a duplication operation. During the first punch clutch cycle, no punching occurs. The punch unit is made operative for the purpose of controlling the action of the pin sense unit and using the P-cam timings. Because no punching occurs, this cycle is called the dummy punch clutch cycle. The operation is explained in "Manual Duplication Sequence Chart."

Manual Duplication (One Column, Program Control Off)

- **The punch unit must go through two cycles of operation for every column duplicated.**
- **A card can be manually duplicated by:**
 1. **Registering a punched card at the read station.**
 2. **Registering a blank card at the punch station.**
 3. **Pressing the dup key (duplication key).**

Description

The first punch cycle (dummy) is used to read the holes in the card at the read station and store this information (mechanically) in the punch unit. The second punch cycle is used to punch the stored information into the blank card at the punch station. This action occurs when the dup key is pressed.

For the following manual duplication operation, assume that program control is off (starwheels raised) and the card punch is in alphabetic shift. Cards have been fed and registered. The program drum and master card are registered in column 1. The detail card is always one column behind the program drum and master card; therefore, it is registered in column 0. With the cards and program drum in this position, duplication can take place. The objectives of manual duplication with program control off are:

1. Press the dup key. (7A)
2. Restore the keyboard.
3. Read the master card (dummy punch clutch cycle).
4. Escape.
5. Punch.

Figure 3-21 shows a simplified block diagram and a sequence chart of the manual duplication operation with program control off.

The dummy punch clutch cycle is used to read the card at the read station. During this cycle, the dup-2

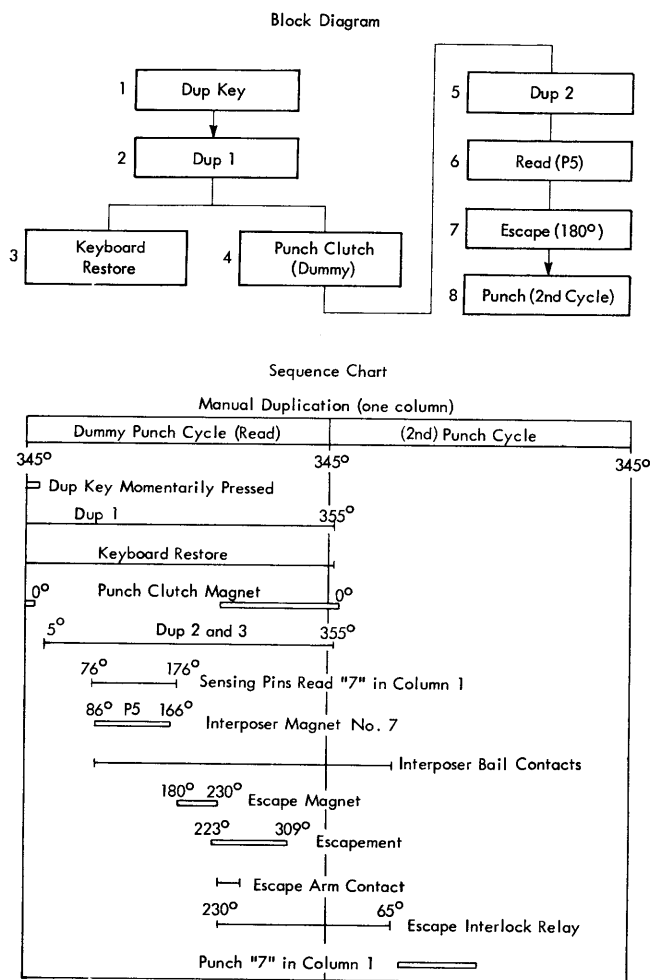

Figure 3-21. Manual Duplication (Program Control Off)

and -3 relays are picked. This completes a circuit through the sensing pin contacts to energize the proper interposer magnets. During this first punch clutch cycle, no punching occurs. The punch unit is made operative for the purpose of controlling the action of the pin sense unit.

After the interposer magnet is energized, the operation is similar to manual punching. Energizing an interposer magnet closes the interposer bail contacts and energizes the escape magnet. The escape magnet allows the cards to move and closes the escape armature contact, which picks the escape interlock relay. The escape interlock relay opens the circuit to the escape magnet and allows the escape magnet armature to fall back in the next tooth on the escape wheel. This relay also energizes the punch clutch, and the information read on the previous cycle is punched into the corresponding column at the punch station.

Circuit Objectives

Refer to Figure 3-21. The digit 7 is punched in column 1 of the master card. This card is registered in column 1, and the detail card is registered in column 0. Manually duplicate column 1:

1. Energize dup-1 relay 7. (8A)
Dup keystem contact. (7A)
2. Energize the punch clutch magnet. (10A)
7-3. (10A)

The punch unit now begins to operate in preparation for reading the card.

NOTE: This completes through the 4 block and begins the dummy punch clutch cycle on the sequence chart.

3. Energize the keyboard restore magnets. (10B)
7-6. (9B)
The keyboard is held restored until dup-1 relay 7 drops out. (8A)
4. Pick dup-2 and -3 relays 8 and 4 at 5°. (8B)
7-2. (7B)
P3 (M5°-B65°). (7B)
5. Hold dup-2 and -3 relays 8 and 4. (8B)
8-1. (8A)
7-1. (8A)

6. Hold dup-1, -2, and -3 relays either through the escape interlock relay or P4 until 355° of the next punch cycle.

- 8-1 (for hold on dup-2 and -3 relays only). (8A)
9-6 N/O. (7A)
P4 (M175°-B355°). (7A)

7. Energize the 7-interposer magnet.
 - a. The punch shaft is turning.
 - b. The sensing pins are rising.
 - c. The master card is read. There is a 7 in the column to be duplicated. The 7-sensing pin contact reads the 7-hole in the master card.
- 7-5. (1B)
P5 (card at read station is read between 86° and 166°). (1B)

The interposer is unlatched but fails to hook on the punch bail because it has already started downward.

NOTE: This completes block 6 and about ½ through the dummy punch clutch cycle of the sequence chart.

8. Close interposer bail contacts. (12B)
Energizing the interposer magnet unlatches the interposer, which closes the interposer bail contacts.
9. Energize escape magnet when the punch shaft gets to 180°. (12B)
 - a. The punch shaft is approaching the halfway point of its first revolution.

- b. At approximately 176° the sensing pins are lowered away from the card.
- c. P1 makes at 180° and the escape magnet operates (through the interposer bail contacts). (12B)
- d. Both cards escape one column.
- e. The master card is now registered in column 2.
- f. The detail card is registered in column 1 and is ready to be punched on the next punch cycle.

NOTE: This completes block 7 and ¾ through the dummy punch clutch cycle of the sequence chart.

10. The keyboard restore magnets are energized. (10B)

7-6 points are transferred. (9B)

From here on, the operation is similar to manual punching.

11. Pick escape interlock relays 9 and 10. (10A)

Escape armature contact closes. (9A)

12. Relays 9 and 10 hold until 65°. (10A)

10-1. (10A)

P2 (M135°-B65°). (9A)

13. Energize punch clutch magnet. (10A)

9-4. (9A)

Escape armature contact. (9A)

The punch unit is now approaching the end of its first cycle of operation. The punch clutch magnet is energized until P1 breaks at 0° of the next punch cycle. The clutch sleeve does *not* latch on the tip of the magnet armature, and the punch unit continues into another cycle of operation.

During this second punch cycle, the previously tripped-off interposer is hooked on the bail. The 7-hole is punched in column 1 of the card at the punch station.

14. Keyboard restore magnets drop at approximately 65°. (10B)

Interposer bail contacts. (12B)

15. Escape interlock relays drop at 65°. (10A)

P2 breaks at 65°. (9A)

As the punch bail returns to normal, the interposer that was hooked on the bail is restored on its armature.

This completes the block diagram and the sequence chart (Figure 3-21).

The digit 7 has been manually duplicated from the master card into the detail card.

Manual Duplication Sequence Chart

- Figure 3-21 (Sequence Chart) shows two punch clutch cycles.
- Both punch clutch cycles start at 345° because this is where the punch clutch is latched.

- **Digit 7 is being read in column 1 of the master card and duplicated into column 1 of the detail card.**

Pressing the dup key starts a manual duplication operation. At this time, the punch clutch shaft is latched at 345°. Pressing the dup key picks the dup-1 relay, which stays energized until 355° of the following punch clutch cycle. The dup-1 relay energizes the keyboard restore magnets and the punch clutch magnet.

The dup-2 and -3 relays pick at 5° and stay energized until 355° of the following punch clutch cycle. The dup-1 relay completes a circuit to the pin sense contacts and interposer magnets. Therefore, this relay must be energized to read a card at the pin sense unit (read station).

The punch shaft continues to turn and allows the sensing pins to rise and read the card between 76° and 176° as shown in the mechanical timing chart (Figure 2-14). A pin going through the 7-hole in column 1 of the card allows a CB to energize the 7 interposer magnet between 86° and 166° of the punch cycle. The 7 interposer will not hook onto the punch bail because the punch shaft is turning and the punch bail has already started down.

The tripped off interposer closes the interposer bail contacts. In a manual punch operation, this would immediately give an escapement because the punch clutch is at 345° and P1 is closed. During this operation, the interposer bail contacts transfer at approximately 86°. The punch shaft is turning but the escape magnet is not energized until 180° of this punch cycle because P1 supplies the +48 volts to the escape magnet.

The reason for waiting until 180° before an escapement can take place is to delay movement of the card until the sensing pins leave the holes in the card. The sensing pins are raised and reading the card from approximately 76° to 176°. If the card moves before the pins leave the holes in the card, the card movement will be restricted. Even if there are no holes in the card, the pressure of the pins against the card will hold the card back if an escapement is attempted at this time.

Mechanical Relationship — Punch Index and Escapement

- The sensing pins read the card from approximately 76° to 176°.
- Escapement does not take place until 180° of the punch cycle because P1 does not make until this time.

- **When P1 makes, the sensing pins have been lowered and the card is free to move.**

Description

An approximate mechanical relationship between the punch index and escapement can be established. This relationship will show that the escape magnet is energized for approximately 50° of the punch cycle.

To arrive at this relationship, the following information is given: The punch unit operates at 1,200rpm or 20 revolutions per second; therefore, a punch unit travels 7,200° per second or 7.2° per millisecond. When the release key is pressed, the escapement can travel from column 1 to column 1 (86 teeth on the escape wheel) in approximately 1 second. This means, that one tooth on the escape wheel moves past a given point in approximately 12 milliseconds (Figure 3-22).

It takes approximately 6ms to move the escape armature out of the tooth of the escape wheel and another 3ms to pick the escape interlock relay and break the escape magnet circuit. Therefore, the escape magnet is energized approximately 7ms, or 50°, from 180° to 230° of this punch clutch cycle. This is shown on the sequence chart in Figure 3-21.

During a duplication operation, the escape wheel moves past a given point at an approximate rate of 12ms per tooth. The movement of one tooth on the escape wheel requires 12ms or 86° on the punch clutch index. The escapement takes place from approximately 223° to 309° of this punch cycle.

The escape magnet closes the escape armature contact and energizes the escape interlock relays at about 230°. The pick impulse lasts 8ms (57°) or until 287°. The escape interlock relays then hold until 79° of the next punch clutch cycle.

As soon as the escape interlock relays pick, the punch clutch magnet is energized in preparation for the next punch cycle and stays energized until 0° of the next cycle. A tripped off interposer cannot be re-

stored until it hooks on the bail and is pulled down below the notch in its associated interposer magnet armature. In the following paragraph, the 7 interposer trips off but does not hook on the bail.

The punch clutch shaft is still turning. The tripped off 7 interposer, which does not hook on the bail the first time, now hooks on at approximately 220° as the punch bail returns to its normal position. As we approach 345°, the escape interlock relays are still energized and another punch clutch cycle is initiated.

The first cycle was the dummy punch cycle because no punching took place; the second cycle is the actual punch cycle. It was initiated because the punch clutch magnet is energized before 345° through the escape interlock relays, therefore the punch clutch will not disengage.

During this second cycle, the 7-hole that was read on the first cycle is punched into column 1 of the card at the punch station. Dup-1, -2, and -3, and the keyboard restore magnets all drop at 355°. The escape interlock relays drop at 79°. The punch unit latches at 345°, as the 7 interposer is restored.

Manual duplication (Figure 3-21) can be summarized as follows:

1. Pressing the dup key picks the dup-1 relay.
2. This relay holds the keyboard restored and starts a dummy punch clutch cycle.
3. During this cycle, the dup-2 and -3 relays are picked, and the card is read by the pin sense unit in the read station.
4. An escapement occurs which causes another punch clutch cycle.
5. The information is punched and the operation is completed.

Manual Duplication (More Than One Column)

- **Holding the dup key pressed continues manual duplication.**
- **Two punch cycles are required for each column duplicated.**
- **Cards are alternately read on one cycle and punched on the next cycle.**
- **Figure 3-23 is a sequence chart showing two columns of information being duplicated, and four punch cycles.**
- **The first and third cycles are dummy punch cycles, and the second and fourth are actual punch cycles.**

Description

During the first cycle of operation, the card is read between 86° and 166°. The escape magnet is energized at 180°. This occurs just as it did on the single-column manual dup operation.

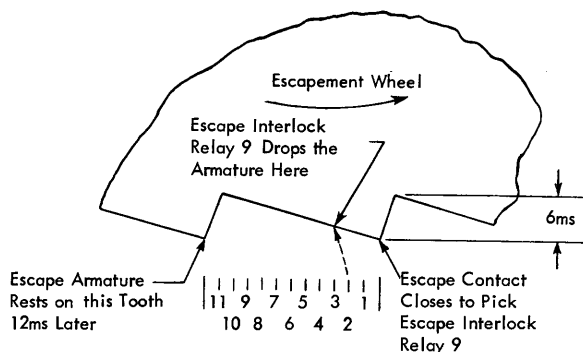

Figure 3-22. Escapement Timing

During the second cycle of operation (Figure 3-23), punching takes place as before. However, unlike the single-column dup operation (see Figure 3-21), the dup key is held pressed. The dup-1 relay and keyboard restore magnets are again energized at 65° as a result of dropping the escape interlock relays.

During the second cycle, *the card is not read*. Because the dup-2 and -3 relays are not picked, the dup-2 and -3 relay points are open and there is no circuit to energize the interposer magnets. The pick of dup-2 and -3 relays 8 and 4 is controlled by the dup-1 relay and P3. Since dup-2 and -3 must be picked before 65° of *any* punch cycle, and dup-1 is not picked until 65° of *this* punch cycle, dup-2 and -3 cannot be picked and the card at the pin sense station is not read at this time.

This is why a card is not read on the actual punch cycle in a manual dup operation and also why an auto dup operation is twice as fast as a manual dup operation. During auto dup operations, there is a circuit to keep dup-2 and -3 energized for the entire operation.

Circuit Objectives

Refer to Figure 3-23.

1. First cycle of operation occurs as it did on the single column dup operation:

- The card is read between 86° and 166°.
- The interposer magnets are energized.
- The escape magnet is energized at 180°.
- The punch clutch magnet is energized at 230°.
- The card is not punched.

2. Second cycle of operation:

- The card is not read.
- The punch clutch magnet is energized at 180°.
- The card is punched.
- The dup key is held pressed.

Pick dup-1 relay 7 and energize keyboard restore magnets at 65°. (8A)

9-2. (8A)

P2 drops escape interlock relay at 65°. (10A)

Dup keystem contact.

Dup-2 and -3 relays 8 and 4 are not picked.

Dup-1 relay 7 dropped at 355°. (8A)

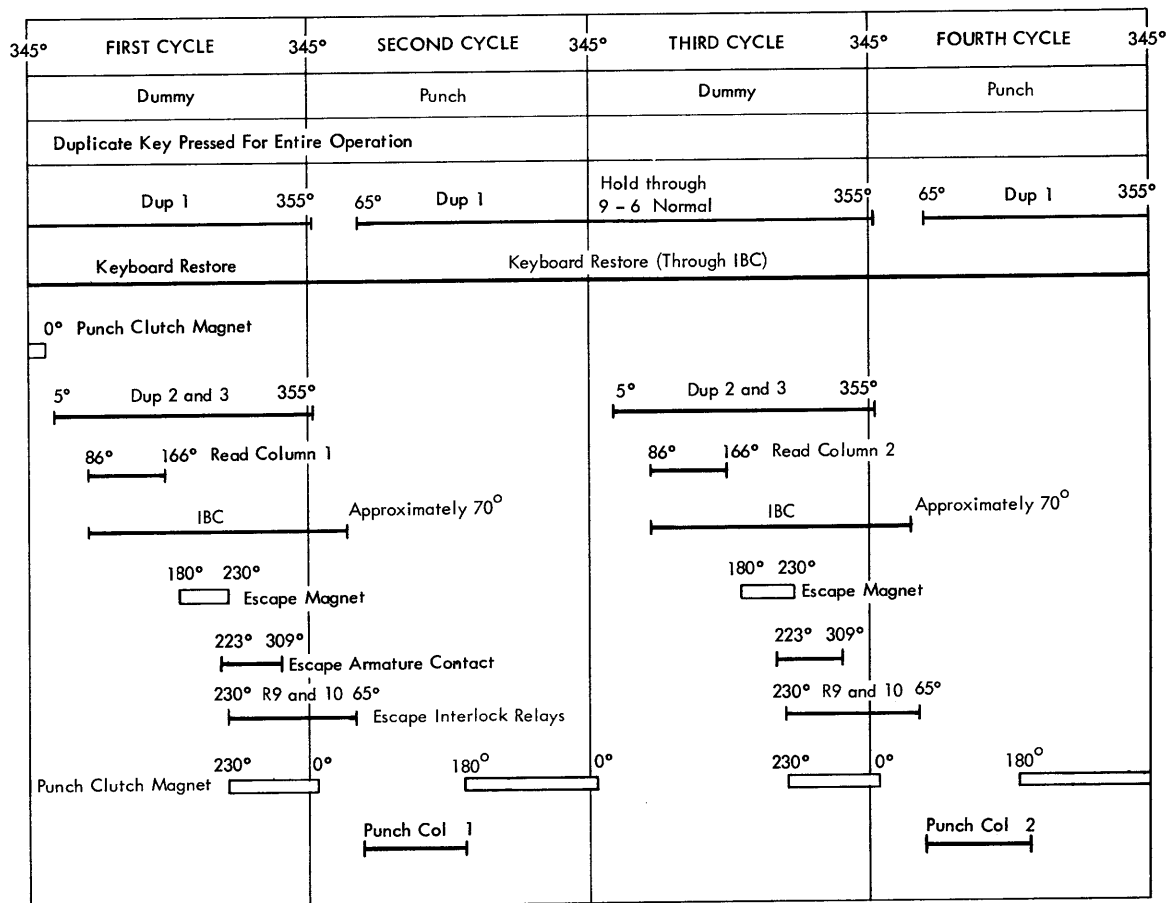

Figure 3-23. Manual Duplication (More Than One Column)

- 7-2 open until 355°. (7B)
 P4 breaks at 355°. (7A)
 Dup-3 points prevent circuit to interposer magnets. (2A)
 Dup-1 relay 7 repicks at 65° of second cycle. (8A)
 Dup keystem contact. (7A)
 9-6 is normal. (7A)
 Relays 9 and 10 are normal from 65° of the second cycle to approximately 230° of the third cycle, allowing a hold circuit for relay 7 through 9-6 points.
3. Third cycle of operation:
 Escape interlock relays 9 and 10 are normal until 230°. (10A)
 Dup-1 relay 7 holds from 65° of second punch cycle until 355° of fourth cycle. (8A)
 P4 (M175°-B355°). (7A)
 Card at read station is read and cards escape:
 Dup-2 and -3 relays 8 and 4 picked. (8B)
 P3 makes at 5°. (7B)
 Escape interlock relays 9 and 10 picked.
 4. Fourth cycle of operation:
 The card is punched.

Manual Duplication (Program Control On)

- **The starwheels are lowered, the machine is in numeric shift, and the dup key starts the operation. (The master card must have a punched hole or no escapement will take place.)**
- **An escapement occurs and each punch cycle is also a read cycle under the control of field definition. Duplication continues to the end of the field.**
- **The first cycle is a dummy punch cycle. The second and third cycles are combination read and punch cycles. In a three-column field, the fourth cycle is a punch cycle only.**

Description

Figure 3-24 shows a block diagram and a sequence chart of manual duplication with program control on.

1. Pressing the dup key picks dup-1 relay 7.
2. The dup-1 relay holds the keyboard restored and starts a dummy punch cycle. During this cycle, dup-2 and -3 relays 8 and 4 are picked, and card column 1 is read by the sensing pins.
3. An escapement occurs and a circuit is completed through the 12 or 4 starwheel to continue duplication. This hole in the program card provides a hold circuit for the dup-1, -2, and -3 relays.
4. After an escapement, another combination read and punch cycle takes place. During this cycle, column 3 is read and column 2 is punched.
5. Another escapement takes place, and the final punch cycle punches column 3.

Circuit Objectives

Refer to Figure 3-24. Program 1 mode, program control is on, and the first three columns of the program card are punched to designate a manual numeric field.

1. First cycle of operation:
 Dup-1 relay is picked through dup keystem contact. (7A)
 Dup-1 relay holds the keyboard restored and starts a dummy punch cycle.
 During this cycle, the dup-2 and -3 relays are picked, and card column 1 is read by the sensing pins. (8B)
 An escapement occurs and, as the program card moves into column 2, the starwheel falls into the 12-hole in the program card. The 12-starwheel contact provides a hold circuit for dup-1, -2, and -3 relays.
2. Second cycle of operation:
 With dup-1, -2, and -3 relays held during the second cycle, the card at the read station is read in column 2, and the card at the punch station is punched in column 1.
 The keyboard restore has a continuous hold through the dup-1 relay (7-6).
 The escape magnet is energized at 180° by the interposer bail contacts.
 The master card moves to column 3, and the detail card moves to column 2.
 The program drum moves to column 3, and the starwheel is still in a 12-hole in the program card.
3. Third cycle of operation:
 The 12-starwheel contact holds the dup-1, -2, and -3 relays.
 The card at the read station is read in column 3, and the card at the punch station is punched in column 2.
 The escape magnet is energized at 180°.
 The master card moves to column 4, and the detail card moves to column 3.
 The program drum moves to column 4, which causes the 12-starwheel contact to break and open the circuit to dup-1, -2, and -3 relays.
4. Fourth cycle of operation:
 The dup-1, -2, and -3 relays drop at 355°.
 The card will *not* be read (dup-1 and -3), and a new punch cycle will *not* be initiated.
 The card at the punch station is punched in column 3.

Automatic Duplication

- **The auto skip/auto dup switch must be on.**
- **Automatic duplication is initiated by sensing a 0-hole in the program card in program 1 mode, or a 6-hole in program 2 mode.**

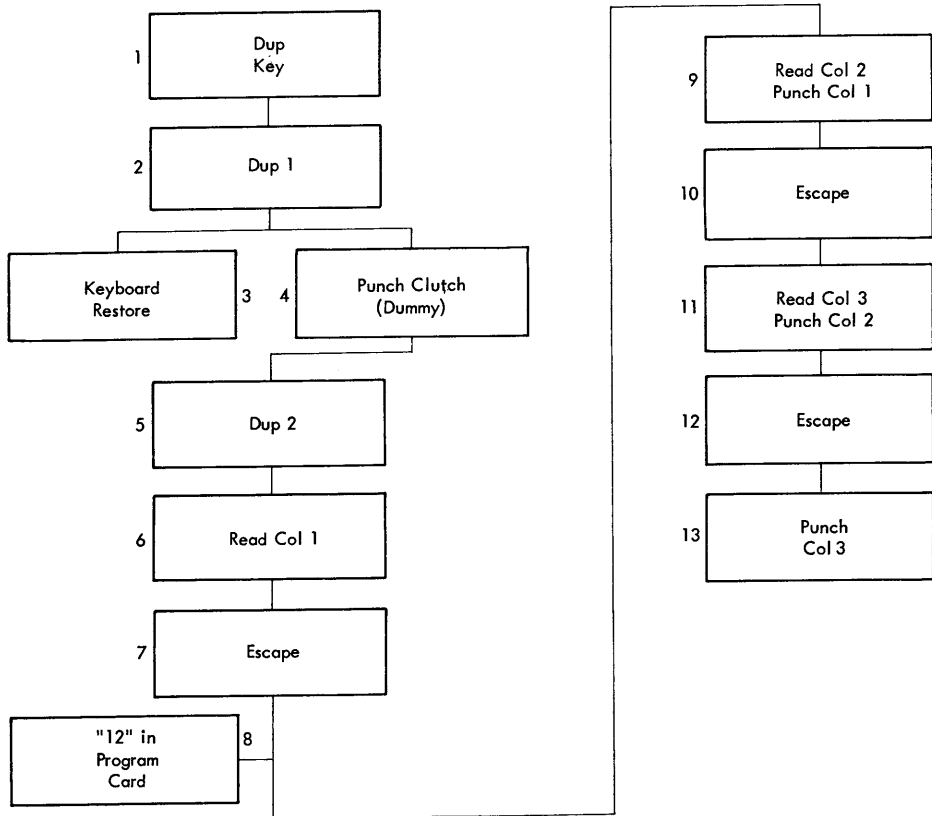

BLOCK DIAGRAM

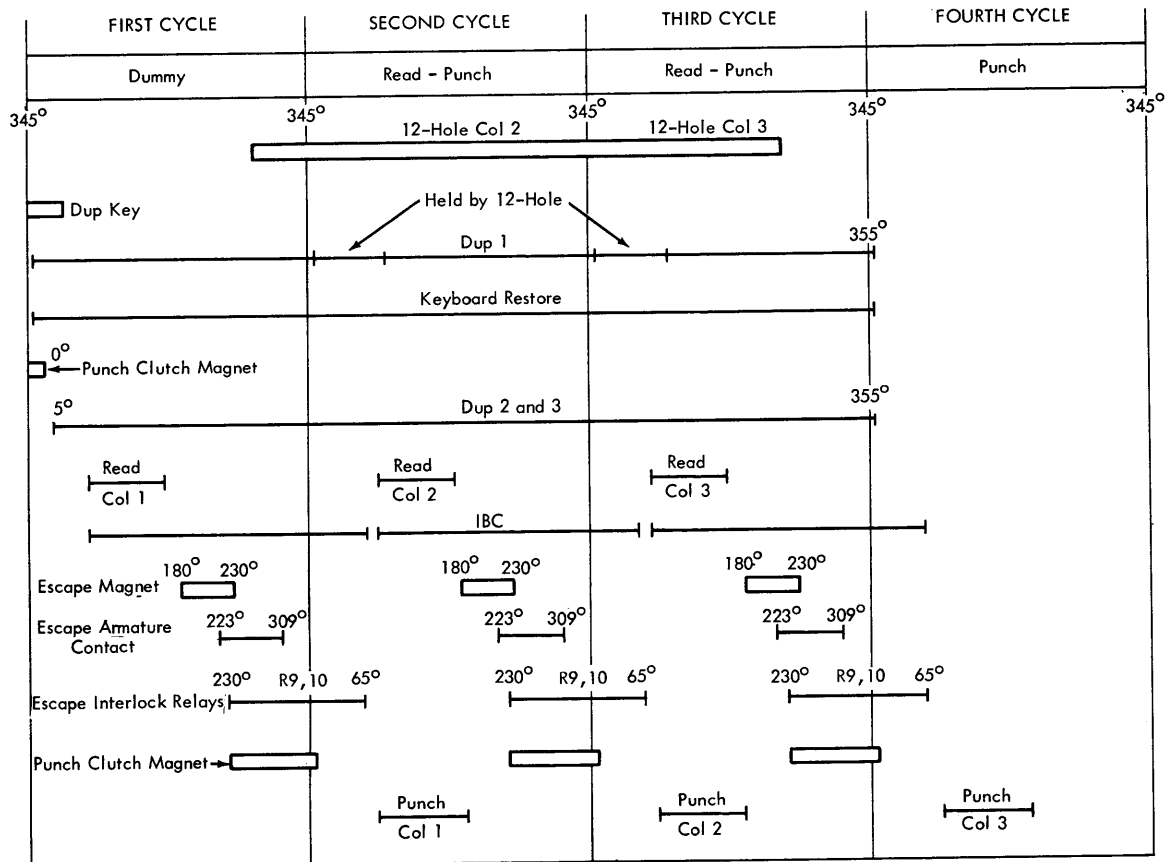

SEQUENCE CHART

Figure 3-24. Manual Duplication (Program Control On)

Description

The only difference between manual dup, program control on, and auto dup is the way each operation is started. The first cycle is a dummy punch cycle to read the hole in the first column of the field in the master card. The machine then escapes one column and takes another punch clutch cycle to punch the character that was read in column 1. During this second punch cycle the machine also reads the second column of the field. The sequence of reading one column, punching the previous column, and escaping, continues until the end of field definition.

The machine is normally in numeric shift, because the starwheels are down, and locks up on a blank column unless the machine is placed in alpha shift.

Circuit Objectives

Refer to Figure 3-25. Read a zero (program 1 mode) in the program card, take a read cycle, and escape one column.

1. First cycle of operation:
 - a. Pick dup-1 relay.
Zero (dup) program sensing contacts.
 - b. Hold dup-1 relay.
7-1.
A parallel path: P4 (M175°-B355°) to +48 volt backspace or 9-6 N/C to +48 volts.
 - c. Energize the keyboard restore magnets.
 - d. Energize punch clutch for dummy punch cycle.
7-6.
 - e. Pick dup-2 and -3 relays at 5°.
7-2.
P3 (M5°-B65°).
 - f. Hold dup-2 and -3 relays.
8-1.
Zero starwheel contact.
 - g. Read first column of master card.
Dup-1, 7-5, and dup-3 points.
P5 (M86°-B166°).
 - h. Energize escape magnet.
Interposer bail contacts.
 - i. 12-starwheel contact makes, 0-starwheel contact breaks.
Program drum moves from column 1 to column 2.
 - j. Hold dup-1, -2, and -3 relays.
P4 (between 0-starwheel break and 12-starwheel make).
12-starwheel contact.
 - k. Energize punch clutch magnet.
2. Second, third, and fourth cycles of operation:
 - a. The 12-starwheel contact holds the dup-1, -2, and -3 relays, and continues duplication.

- b. A combination read-and-punch cycle is initiated as a result of the 12-starwheel holding dup-1, -2, and -3 relays.
- c. During the second cycle of operation, column 2 is read and column 1 is punched.
- d. After an escapement, another combination read-and-punch cycle takes place.
- e. During the third cycle of operation, column 3 is read and column 2 is punched.
- f. Another escapement occurs, field definition is lost (no 12-hole in column 4 of the program card), and the final punch cycle punches in column 3.

Skipping

- **Cards can be skipped by two methods:**

1. **Manual skip (with or without program control).**
2. **Automatic skip (under program control).**

With program control off, pressing the skip key results in the card punch taking a single space. With program control on, the skip key initiates the escapement, and the field definition punches continue the skip to the end of the field. With a blank program card, pressing the skip key results in the card punch taking a single space.

Sensing an 11-punch (program 1 mode) or 5-punch (program 2 mode) initiates a skip automatically. The field definition punches in the remaining columns continue the skip through the rest of the field. This is an auto skip field. The auto skip operation is made active by lowering the starwheels and turning on the auto skip/auto dup switch.

Manual Skip – Program Control Off

- **Each skip key depression causes a single-column escapement and a punch cycle.**

Description

Pressing the skip key closes the skip key latch contact and energizes the escape magnet. The escape magnet causes an escapement and closes the escape armature contact, which picks the escape interlock relays and the skip relay. The escape interlock relays (9 and 10) drop out the escape magnet and energize the punch clutch magnet.

The punch clutch magnet starts a punch cycle. The keyboard is restored through points of the skip relay.

Circuit Objectives

1. Energize escape magnet. (12B)
Skip key latch contact. (4A)

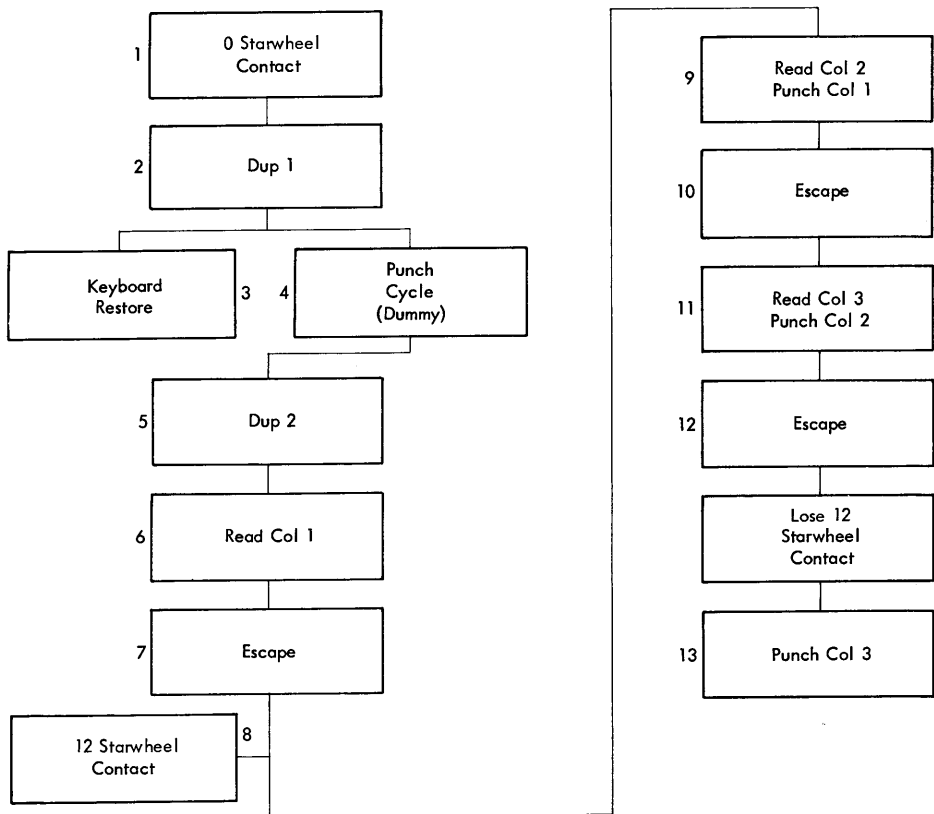

BLOCK DIAGRAM

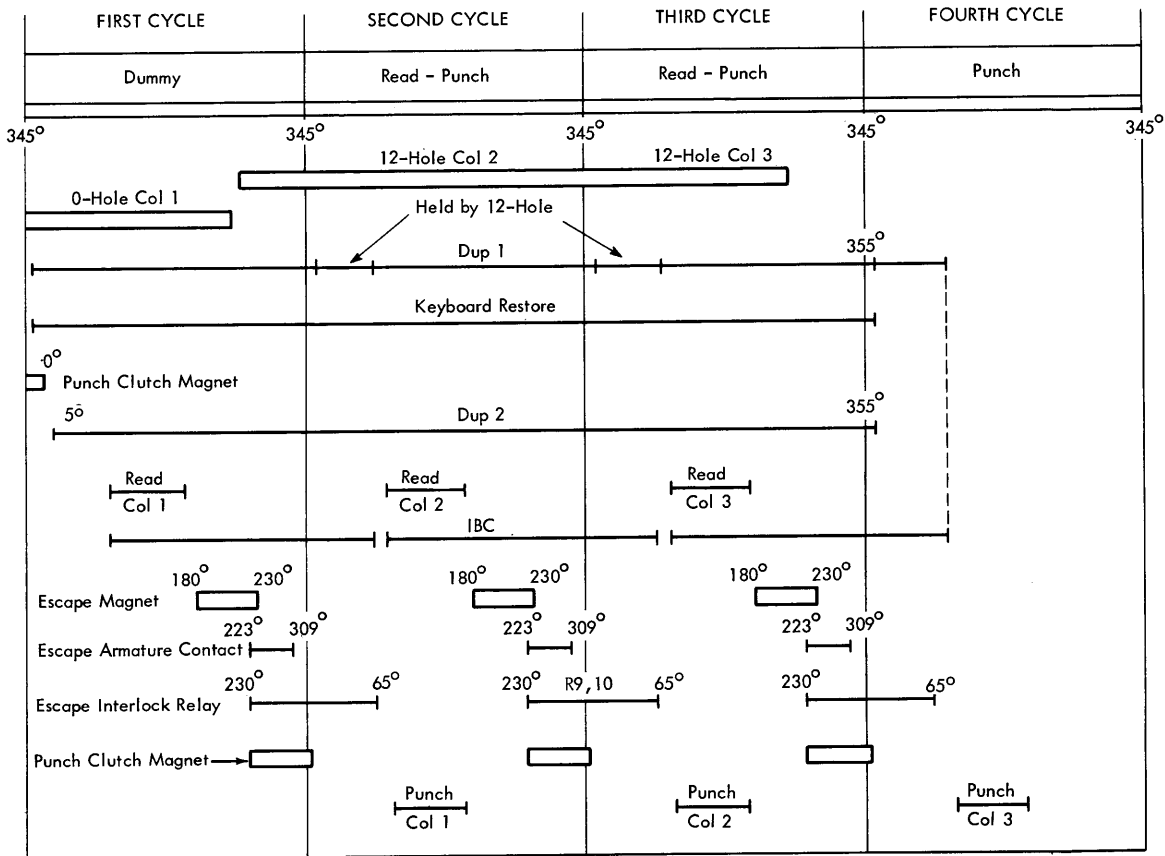

SEQUENCE CHART

Figure 3-25. Automatic Duplication

2. Pick escape interlock relays 9 and 10. (10A)
Escape armature contact. (9A)
3. Pick skip relay 19. (12A)
9-1. (12A)
4. Energize keyboard restore magnets. (10B)
19-4. (9B)
5. Drop escape magnet.
10-4. (12B)
6. Energize punch clutch magnet. (10A)
9-4. (9A)

Manual Skip — Program Control On

- **Press skip key to initiate operation. 12-holes or 4-holes in program card continue the operation.**
- **Major objectives of a skip key operation are:**
 1. **Hold the keyboard restored.**
 2. **Cause an escapement.**
 3. **Energize the punch clutch for one cycle.**
 4. **Hold the skip relay.**
 5. **Energize the escape magnet under control of the 12-program contact.**

Description

During a manual skip operation when there is field definition in the program card, pressing the skip key causes the machine to escape one column, execute a punch clutch cycle, and skip remainder of the field.

The skip key picks the escape magnet. A punch cycle takes place and the skip relay picks. Because this is to be a continued skip operation, the 12-holes provide a hold circuit for the skip relay, which in turn moves the card by energizing the escape magnet.

NOTE: Pressing the skip key with program control on and a blank card on the program drum causes an escapement and a punch clutch cycle. The card moves only one column because there is no hold circuit for the skip relays.

Circuit Objectives (with Field Definition)

1. Energize escape magnet. (12B)
Skip key latch contact. (4A)
2. Pick escape interlock relays 9 and 10. (10A)
Escape armature contact. (9A)
3. Pick skip relay 19. (9-1) (12A)
4. Energize keyboard restore magnets. (10B)
19-4. (9B)
5. Energize punch clutch magnet. (10A)
9-4. (9A)
6. Hold skip relay and escape magnet.
12-starwheel contact makes.
7. Drop skip relay and escape magnet.
12-starwheel contact breaks.

Automatic Skipping

- **The objectives of the operation are:**
 1. **Sense an 11-hole in the program card.**
 2. **Keep the keyboard restored.**
 3. **Escape one column and place the skip circuits under field definition control.**
 4. **Skip the remainder of the field.**

The auto skip/auto dup switch is on, and sensing an 11-hole in the program card in program 1 energizes the skip relay (Figure 3-26). This relay keeps the keyboard restored, prevents energizing the punch clutch, and energizes the escape magnet.

Movement of the card opens the 11 program contact and closes the 12 program contact. The 12 contact provides a hold circuit for the skip relay and the escape magnet.

Because the 12-starwheel is not made at the instant the 11-starwheel breaks, a shorted skip relay hold coil (19-1) delays the drop-out time of the skip relay so that the 12-starwheel contact can make and provide a hold for both the skip relay and the escape magnet.

Multipunch (Multiple Punching)

- **Any number of holes can be punched in one column by first pressing the multipunch key, then pressing the desired numeric keys.**
- **One escapement occurs and the punch unit is made operative without the aid of additional escapements as long as the multipunch key is held.**
- **The alpha relay cannot be picked.**

Description

The multipunch (MP) key must be pressed before a character key is pressed. The MP key operates two keystem contacts. The normally open contact is in the circuit to the MP relay, and the normally closed contact is in the alpha relay circuit. The alpha relay is dropped immediately and remains dropped as long as the MP key is pressed, but the MP relay is first picked by the escape interlock and remains held until the MP key-steam is released.

Upon pressing a character key after first holding the MP key pressed, the machine escapes one column and a punch cycle results. The MP relay is held by its own points, through the keystem contacts, and opens the escape-magnet circuit to prevent further escapement.

Should multiple punching occur in column 80 or in the last column preceding a programmed field (*auto skip* or *auto dup*), multipunch points delay the start

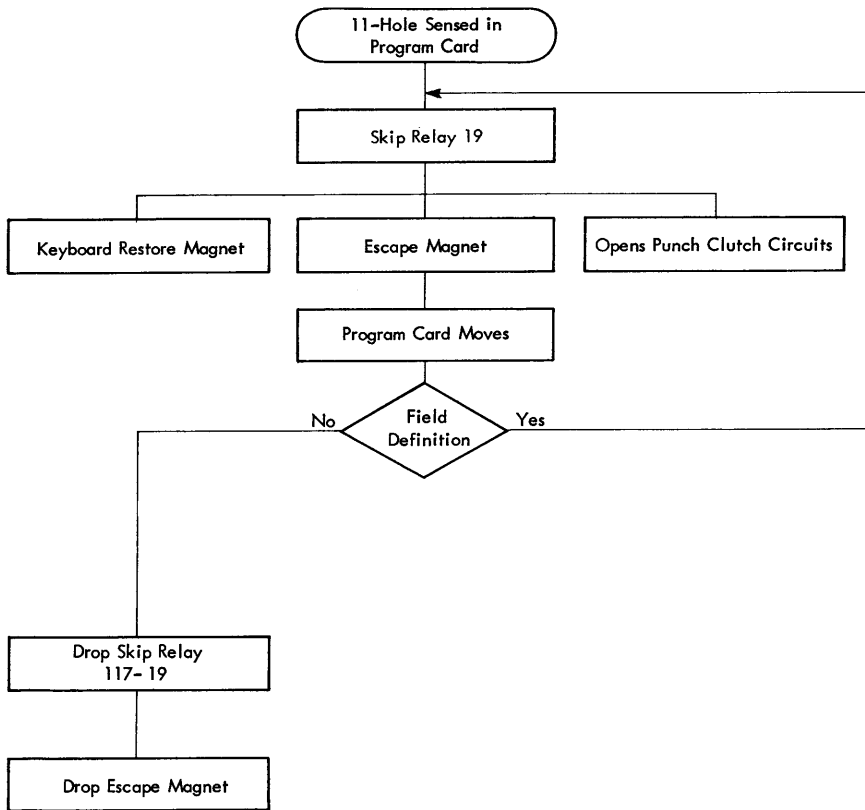

Figure 3-26. Automatic Skip

of the automatic operation until the MULT PCH is released. They also prevent starting a skip if the skip key is pressed during multiple punching.

Circuit Objectives

Refer to Figure 3-27. Prevent escapements after the first cycle of operation, but allow additional punch cycles without an escapement.

1. First cycle of operation:
 - a. Drop alpha relay. (10B)
MP keystem (N/C). (10A)
 - b. Energize escape magnet. (12B)
Interposer bail contacts. (12B)
Interposer magnet energized. (2A)
Numeric keystem.
 - c. Pick escape interlock relays. (10A)
Escape armature contact.
 - d. Pick MP relay. (10A)
MP keystem upper.
9-5 N/O.
 - e. Punch clutch energized.
9-4. (9A)
2. Second MP cycle:
 - a. Escape magnet circuit is open.
23-3 N/C. (12A)

- b. Energize punch clutch without normal escapement.
23-3 N/O. (12A)
Interposer bail contacts.
Interposer magnet energized.

Release Key, Not Programmed, with Cards

- Pressing the release key causes the escape mechanism to move.
- The program drum revolves and stops in column 1.
- The keyboard is restored.
- A card is fed from the hopper if the auto feed switch is on.

Description

A card will move through either the punch or read stations if the escape mechanism moves. Pressing the release key picks the release relay, skip relay, escape magnet, and operates the escape mechanism. This chain of events releases the card positioned at the punch or read station. The program drum revolves in synchronism with the card movement through the punch or read station.

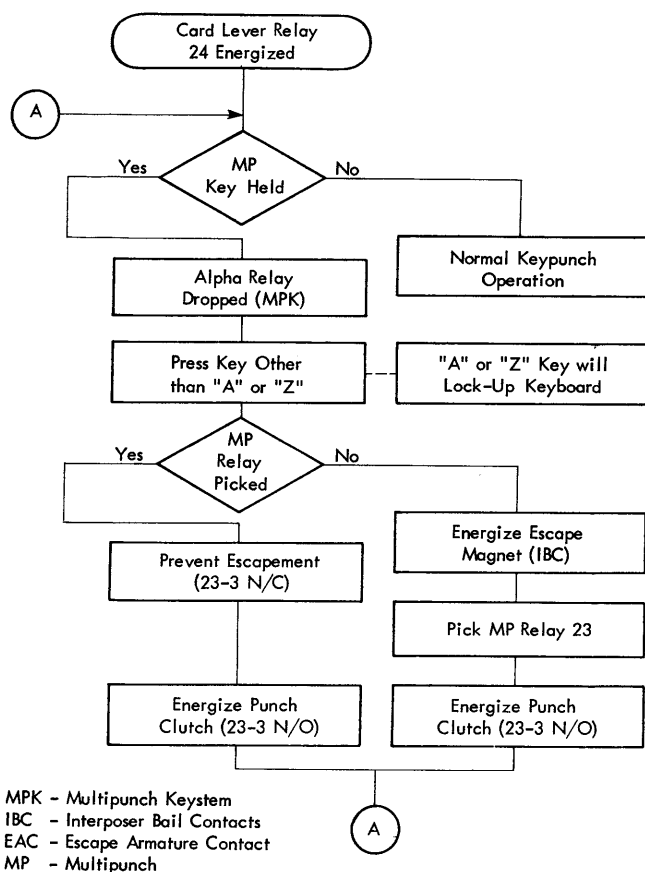

Figure 3-27. Multipunch Operation

The release relay is picked directly through the release key latch contact and +48 volts. Both the release and card lever relays hold under control of PCC2 N/C (program cam contact 2) until the program drum has gone past column 82½ to 84. The release and card lever relays share the same hold circuit.

The release relay points complete a circuit to pick the skip relay. Picking the skip relay energizes the escape magnet.

The escape magnet holds under control of the skip, card lever, and release relays. The program drum must get back to column 1. The release circuit which holds the skip relay and escape magnet opens when the release relay point transfers as the program drum moves past column 82½ to 84. Therefore, to get the drum into column 1, the skip relay and escape magnet are held by another circuit.

Both the skip relay and escape magnet hold under control of program cam contact 1 (PCC1) until column 88½ on the column indicator. When the program drum moves past column 88½, both the skip relay and escape magnet drop, and the program drum stops in column 1. With the auto feed switch on, the card punch automatically goes through a card feed cycle as the pro-

gram drum moves from column 80 back to column 1.

Pressing the release key restores the keyboard. There is an alternate path for restoring the keyboard at this time. The circuit is through a skip relay point and is used on an automatic skip operation when the release key is not pressed.

The keyboard is held restored during an entire skip or release operation. Therefore, no other character key can be pressed while the escape mechanism is moving.

Circuit Objectives

1. Pick release relay 16. (8B)
Release latch contact N/O.
2. Hold release relay 16. (8B)
16-1 N/O. (8B)
3. Hold card lever relay 24. (8B)
24-1 N/O. (8B)
PCC2 (N/C column 82½ to 84). (5A)
4. Skip relay picked and held (19). (12A)
Program handle 1 raised. (11A)
24-5 N/O. (11A)
16-3 N/O. (11A)
5. Energize escape magnet. (12B)
19-6 N/O. (12A)
16-4 N/O. (12A)
Program handle switch 1 raised. (11A)
24-5 N/O. (11A)
16-3 N/O. (11A)
6. Hold skip relay and the escape magnet to get the program drum into column 1:
PCC1 N/O (M column 80½ to 80% - B column 88½). (11A)
7. Restore the keyboard.
Keyboard restore magnets. (10B)
19-4 N/O and 16-2 N/O. (9B)
8. a. Feed a card.
PCC2. (5A)
Auto feed switch on. (5A)
b. With the auto feed switch off, the card does not register at the next station, and there is no card feed cycle.

Release Key, without Cards

- Release without cards is identical to release with cards except the circuit to pick the skip relay and escape magnet is different.

1. Without cards in the machine, the card lever relay is normal (not picked).
2. Pressing the release key energizes release relay 16. (8B)

3. The release relay picks the skip relay through card lever 24-5 N/C and 16-3 N/O. (11A)
4. The escape magnet is energized through 19-6 N/O, 16-4 N/O, 24-5 N/C, and 16-3 N/O. (11A, 12A)
5. The release circuits are controlled through program cam contact 2 until columns 82½ to 84.
6. The pick circuits for the skip relay and escape magnet are controlled through 24-5 N/C.
7. On a release operation, the keyboard is restored through release relay 16-2 N/O and skip relay 19-4 N/O points. (9B)

Release — Program Control On, with Cards

- Press the release key with program control on, and the card lever relays picked, to cause all the programmed operations to occur.
- During the release operation:
 1. A blank field causes auto spacing.
 2. A manual field causes a smooth release or skip.
 3. An auto skip or auto dup field causes the programmed operation to be performed.

Description

The type of field in the program card causes one of four conditions when the release key is pressed with program control on. The starwheels can sense a blank program card, a manual field containing only 12's, an auto skip field, or an auto dup field.

When the release key is pressed, the cards release. A blank field in the program card causes the machine to space or auto space continuously. A manual field, having field definition, causes a smooth release or skip. An auto skip field causes an auto skip operation, and an auto dup field causes the machine to go into an auto dup operation.

Release Key — Blank Field

- The release key operation in a blank field in the program card alternately energizes the escape magnet and the punch clutch magnet.

Circuit Objectives

Refer to Figure 3-28.

1. Pick release relay. (8B)
Release key latch contact.
Holds through PCC2 N/C. (5A)
2. Energize escape magnet. (12B)
19-5 N/C, 24-5 N/O, 16-3 N/O. (11A, 12A)
3. Pick escape interlock relays. (10A)
Escape armature contact.

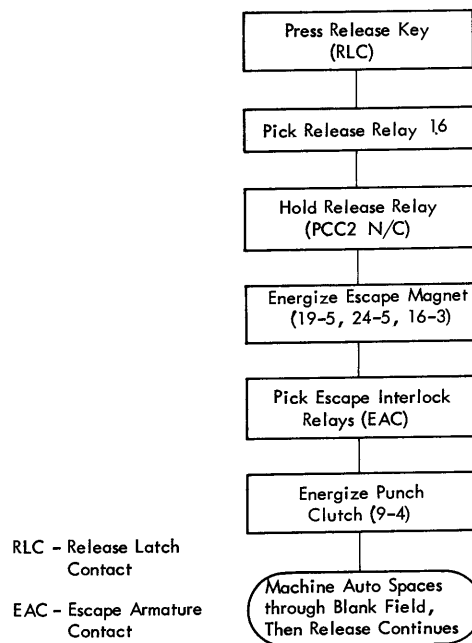

Figure 3-28. Release Key Operation (Blank Field)

4. Energize punch clutch. (10A)
9-4. (9A)
5. Drop escape magnet (stops escapement).
10-4. (12B)
6. During the punch cycle, the escape interlock relays drop, the release is still held energized through PCC2 N/C. As soon as the escape interlock relays drop, the escape magnet is re-energized and the sequence of events (steps 1-5) is repeated.

Release Key — Manual Field

- The release key operation in a manual field (12's or 4's) in the program card results in a smooth skip through the entire field.

Circuit Objectives

Refer to Figure 3-29.

1. Pick release relay (causes card movement).
Release key latch contact.
Holds through PCC2 N/C. (5A)
2. Pick skip relay. (12A)
16-4, 8-6 N/C. (11A, 12A)
Program starwheel contacts 12 or 4.
3. No punch clutch or escape interlock relay circuit.
19-4 N/C. (9B)
4. Energize escape magnet. (12B)
19-6 N/O, 8-6 N/C, 13-4.
Hold through program starwheel contacts 12 or 4.

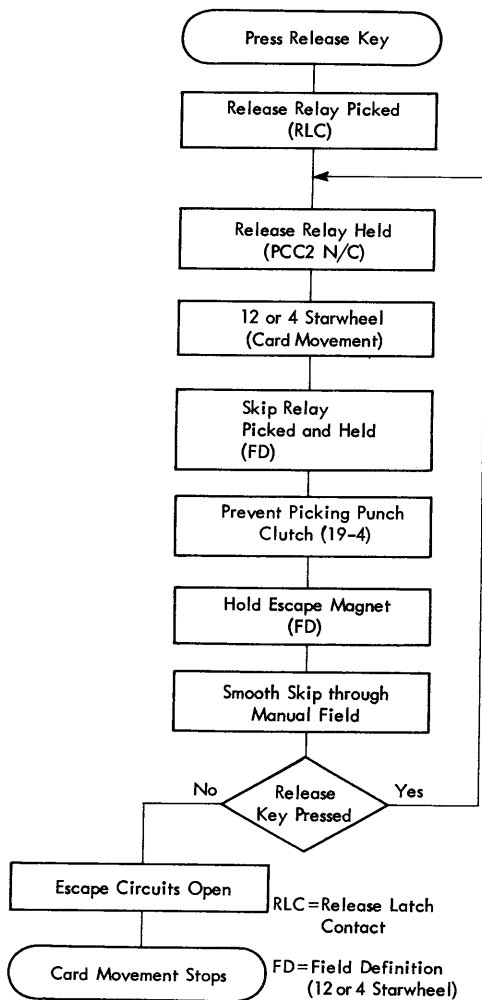

Figure 3-29. Release Key Operation (Manual Field)

Release Key – Auto Skip Field

- The release key operation in an auto skip field (11 or 5 in the program card) with the auto skip/auto dup switch on, results in auto skipping the entire field.

Circuit Objectives

Refer to Figure 3-30.

1. Pick release relay (causes card movement).
Release key latch contact. (7B)
Holds through PCC2 N/C. (5A)
2. Pick skip relay. (12A)
16-3. (11A)
Auto skip/auto dup switch on. (8A)
Program starwheel contacts 11 or 5.
3. No punch clutch or escape interlock relay circuit.
19-4. (9B)

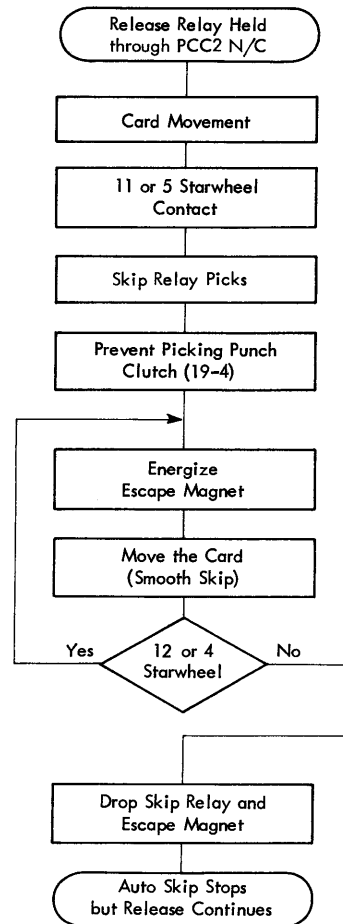

Figure 3-30. Release Key Operation (Auto Skip Field)

4. Energize escape magnet. (12B)
19-6 and 16-4. (12A)
Program starwheel contacts 11 or 5.
Hold through program starwheel contacts 12 or 4.

Release Key – Auto Dup Field

- The release key operation in an auto dup field (0 or 6 in the program card), with the auto skip/auto dup switch on, results in automatic duplicating the entire field.

Circuit Objectives

Refer to Figure 3-31.

1. Pick release relay (causes card movement).
Release key latch contact. (7B)
Holds through PCC2. (5A)
2. Auto skip/auto dup switch is on. (8A)
3. Dup-1 relay picked. (8A)
0 or 6 program starwheel contacts.
4. Release circuit to escape magnet is open.
7-4 N/C. (12A)

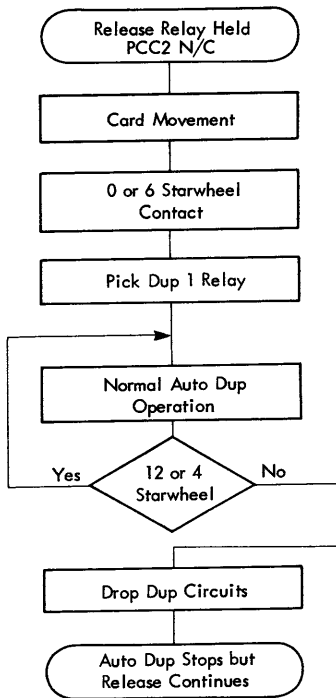

Figure 3-31. Release Key Operation (Auto Dup Field)

5. Auto dup starts under control of the 0 or 6 hole in the program card and continues under control of field definition (12- or 4-hole).

Clear

- The clear operation moves cards from the detail and master stations into the stacker without feeding cards from the hopper.
- The clear switch is a spring-loaded, momentary contact switch, that, when operated, initiates the multiple cycles required to clear the card transport area.

Description

Refer to Figures 3-32, 3-33, and 3-34. Pressing the clear switch picks the clear relay, which is held through its own points, CF2, or read card lever; or its own points and detail card lever. Card lever relay is dropped to make the starwheels inoperative. The release relay is picked through clear; skip relay is picked through release. These two relays allow the escape magnet to be picked. PCC1 transfers at column 80½ to 80%. (PCC1 holds the skip relay.) PCC2 transfers at column 82½ to 84 and drops the release relay. This is to allow the end of card-to-card skip to be under the control of PCC1.

The transfer of PCC2 also energizes the card feed latch magnet through clear relay points, causing a card feed cycle. CF3 makes at 75° and repicks the re-

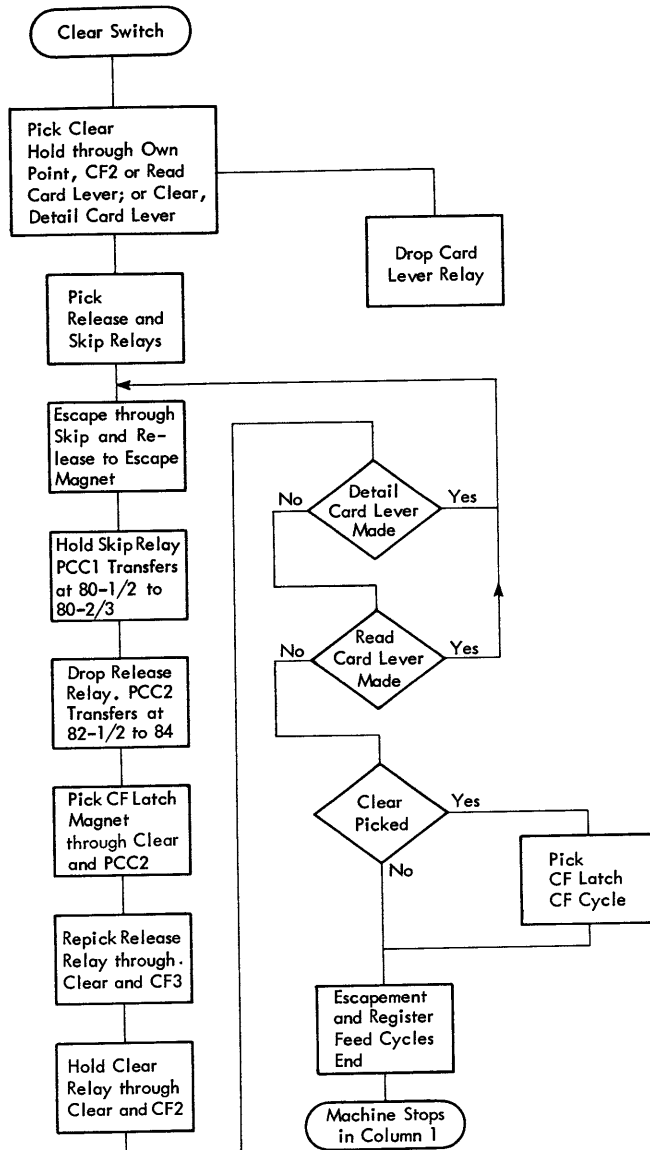

Figure 3-32. Clear Operation

lease relay through clear relay points. The clear relay remains held from CF3 through its own points and detail card lever. CF2 also holds the clear relay.

This operation continues until all cards have gone through the detail station (opening the detail card lever) and the read station (opening the read card lever); then one additional CF cycle is taken. CF2 breaks at 65° and drops the clear relay.

Circuit Objectives

Refer to Figure 3-34. With a card in the detail station:

1. Pick clear relay 17. (8B)
Clear switch. (7B)
2. Hold clear relay 17.
17-1. (8B)
Read card lever or CF2 or detail card lever or CF3.

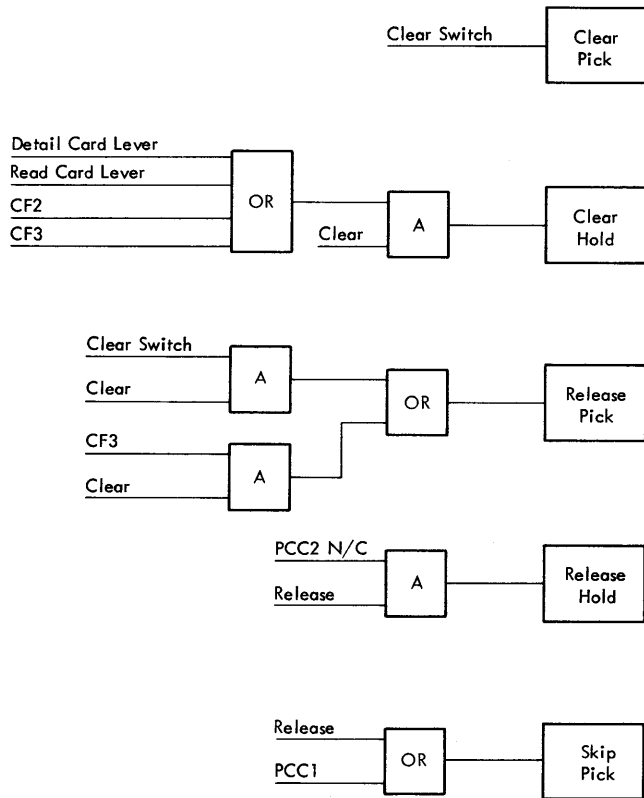

Figure 3-33. Clear - Pick and Hold

3. Drop card lever relay 24. (8B) 17-5.
4. Pick release relay 16. (8B) 17-3 N/O.
5. Starwheel control circuits broken. Card lever relay 24. (8B)
6. Pick skip relay 19. (12A) 16-3. (11A)
7. Energize escape magnet. (12B) 19-6. (12A) 16-3 and 16-4. (11A, 12A)
8. Hold skip relay. (12A) PCC1 makes at column 80½ to 80%. (11A)
9. Drop release relay. (8B) PCC2 breaks at column 82½ to 84. (5A)
10. Cause a card feed cycle. Energize CF latch magnet. (6A) 17-2. (5A) PCC2. (5A)
11. Hold clear relay. (8B) 17-4, detail card lever, 17-5, 17-1. CF3 makes at 75°. (7B)
12. Repick release relay. (8B) 17-6. (8B) CF3. (7B)

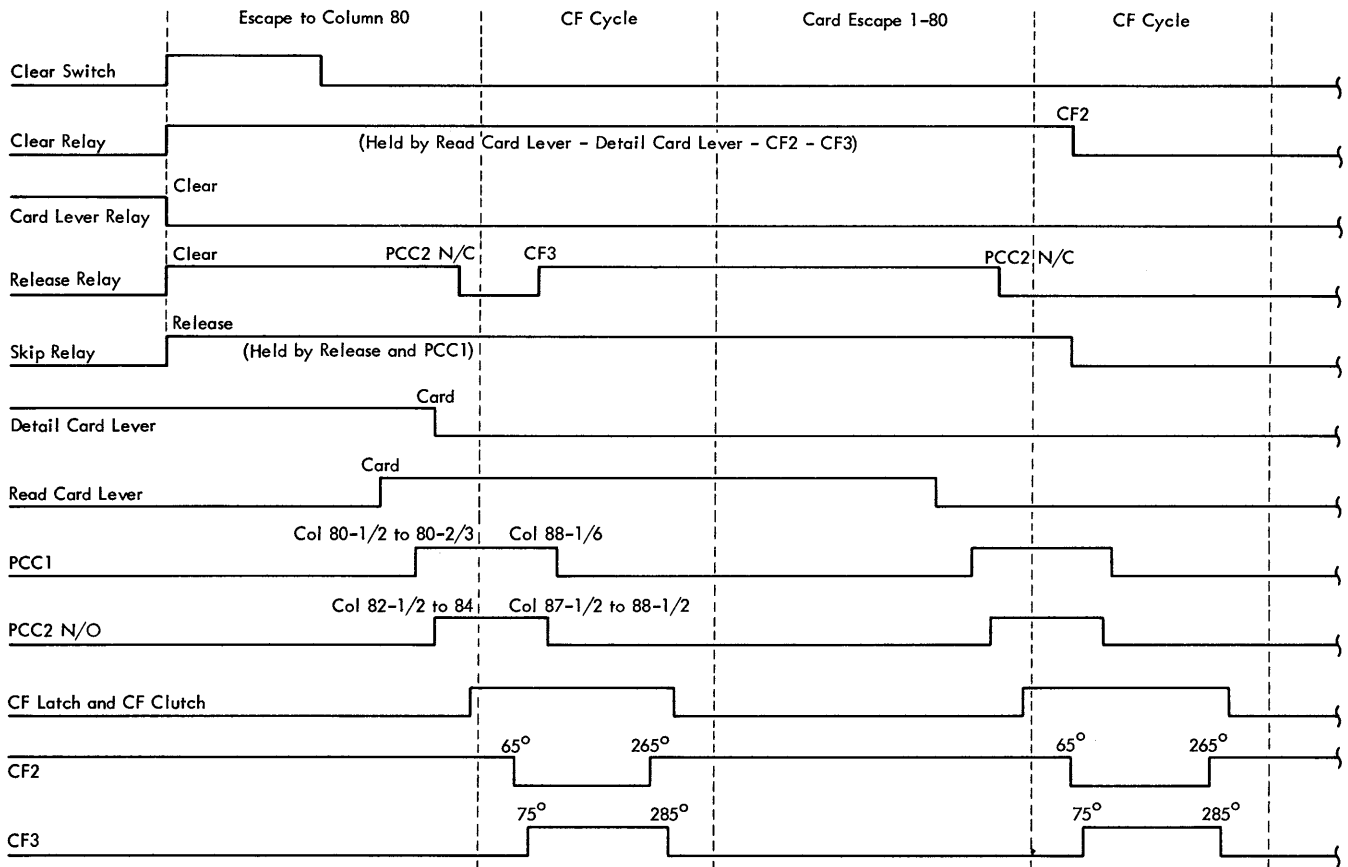

Figure 3-34. Clear Operation (With One Card in Detail Station)

13. Hold clear relay. (8B)
17-1.
CF2. (6A)
14. Drop detail card lever. (8B)
Card through detail station.
15. Drop read card lever. (7B)
Card through read station.
Read card lever opens 180° to 355°.
16. Clear operation ends.
Drop clear relay 17. (8B)
CF2 breaks at 65°. (6A)

Printing Control

- **No printing occurs when the print suppress magnet is energized.**
- **The print suppress magnet is energized when:**
 1. **The print switch is off.**
 2. **The print relay is not picked, program control is on, and field definition (a 12- or 4-hole) is read by the starwheel contacts.**

Description

The print suppress magnet is controlled by two circuits: one through the print switch, and one from field definition (12 or 4 starwheels) through a print relay point.

With the print switch off, printing is unconditionally suppressed. With the print switch off, +48 volts is supplied the print suppress magnet directly.

With the print switch on and the left-zero print switch in the OFF position, printing of zeros to the left of the first significant digit of a field is suppressed.

Left-Zero Print

- **Left-zero printing is controlled by the left-zero print switch on the keyboard switch panel.**
- **The print switch must be on.**
- **With the left-zero print switch on and the starwheels lowered, all zeros print.**
- **With the left-zero print switch off, and the starwheels lowered, printing of zeros to the left of the first significant digit of a field is suppressed.**
- **The units position of the field always prints.**
- **When the machine is unprogrammed or when it is in a field of blank columns in the program card, all columns print.**
- **Zeros always print if the starwheels are raised.**

Description

With the print switch turned on and program control on, the print relay controls the operation of the print suppress magnet. With the print relay picked, the circuit from the field definition starwheels (12 and 4) to the print suppress magnet is open. Under this condition, all characters punched in a card are printed.

The print relay can only be picked when the interposers sense a significant digit or when the left-zero print switch is in the ON position. The hold circuits for the print relay are through its own points to P4 and 19-3 to the field definition starwheels (12 and 4).

With the left-zero print switch off and the machine under program control, the print relay remains normal until a significant digit is sensed. Once the print relay is picked, it holds through P4 as long as there are 12- or 4-holes in the program card.

During an auto dup operation, all zeros to the left of a significant digit will not print. There is no circuit from the zero sense pin to pick the print relay and break the circuit to the print suppress magnet from the field definition starwheels. Therefore, to print zeros in an auto dup operation, the print relay must be picked to prevent the 12 or 4 starwheels from energizing the print suppress magnet. The field definition punches suppress zero printing when the print relay is down and also hold the print relay up to prevent print suppression.

Alphabetic and other characters having a 0-punch print regardless of the setting of the left-zero print switch. The significant digit associated with the punched code for the character, picks the print relay and prevents energizing the print suppress magnet.

Zeros keyed from the keyboard are prevented from printing only when the machine is under program control and with field definition.

When in a manual numeric field and the entire field is punched with zeros, only the last zero in the field will be printed. The printing of the zero in the last column of the field is not suppressed, because the 12- or 4-hole in the program card is not made at print time. Before the key is pressed for this column, the program drum is in the column beyond the card registered at the punch station (program card in column 55, card at punch station in column 54). The zero key is pressed, an escapement occurs, and the 12 starwheel contact opens. The program drum stops in column 56, and the card at the punch station stops in column 55. The punch unit operates at the same time. This zero does print because there is no 12-hole in column 56 of the program card to energize the print suppress magnet. The fact that a zero prints in the units position of a field when the left-zero print switch is off indicates that a significant digit has not been punched ahead of this zero.

Circuit Objectives

1. Suppress all printing:
Energize print suppress magnet. (6B)
Print switch off.
2. Suppress printing of zeros until a significant digit is punched. (The machine is under program control and the left-zero print switch is off):
Energize print suppress magnet. (6B)
12 or 4 starwheel contact.

3. Print the first significant digit after zeros, print all other characters, and print all zeros to the right of significant digits. (The left-zero print switch is off):
Drop the print suppress magnet. (6B)
Pick print relay. (6B)
Digit pin sense contact.
Hold print relay.
P4. (7A)
12 or 4 starwheel contact.

The only feature described in this chapter is the left-zero insertion feature (Model B). For the detailed theory and maintenance of all other features, refer to Field Engineering Theory-Maintenance Manual, *IBM 29 Card Punch Features; 29 Interpreting Card Punch, Model C*, Form 223-2926.

Left-Zero Insertion Feature

- **Zeros are inserted to the left of the first significant digit.**
- **Operator keys exact number without leading zeros.**
- **Only numeric information can be entered.**
- **Keying mistakes can be corrected.**

The left-zero insertion feature permits the operator to key-in only the necessary significant digits in a numeric field. The operator can then press the left-zero key (or dash key for a credit field), and the machine will punch the field with the correct number of zeros in front of the significant number. Only numeric information can be entered into the left-zero field. If a key is pressed that results in punching a 12-hole, plus numeric information, only the numeric information will be stored, but the 12 is punched immediately. An escapement occurs and the left-zero field is lost.

The left-zero feature reduces the total number of key strokes necessary to punch a field. The operator does not need to determine the correct number of zeros to insert in front of the number. If an operator enters the wrong numeric information, the field can be erased and the correct number can be keyed-in prior to pressing the LZ key.

Left-Zero Program Card

- **The size of the left-zero field is determined by the program card.**
- **A maximum of eight columns and a minimum of three columns can be programmed.**

The size of a left-zero field is determined by the program card coding (Figure 4-1). The first column of the field, high order, is punched with the correct digits to indicate field length. The remainder of the field is defined by 4's or 12's for field definition. The field cannot be less than three columns nor more than eight columns in length.

Field Size	PROGRAM 1		PROGRAM 2	
	First Column	Remaining Columns	First Column	Remaining Columns
8	2	12	8	4
7	3	12	9	4
6	2-3	12	8-9	4
5	1-2	12	7-8	4
4	1-3	12	7-9	4
3	1-2-3	12	7-8-9	4

Figure 4-1. Left-Zero Program Card Coding

Left-Zero Error Reset Key

- **Erases information stored in left-zero registers.**

When the operator presses the error reset key, the +48 volts is removed from the left-zero circuits, and all relays drop. The left-zero control relays will repick when the key is released.

Left-Zero Relays

The additional reed relays needed for the operation of the left-zero feature are mounted on two added relay boards (Figure 4-2).

The left-zero circuitry for wire contact relay machines is shown in Figure 4-3.

Principles of Operation for Reed Relay Machines

- **Key the significant number.**
- **Make corrections before the field is punched.**
- **Press the left-zero key or dash key.**

Using the program card shown in Figure 4-4, the machine stops in the high-order column of the left-zero fields. The operator may key in any number of significant digits in each field. However, if the field size is exceeded, the first digits will be shifted out and lost. Thus, incorrect information may punch out when the left-zero key or dash key is pressed.

Read In

- **The program card coding (Figure 4-4) indicates a left-zero field of each size.**
- **The operator presses the first digit key.**

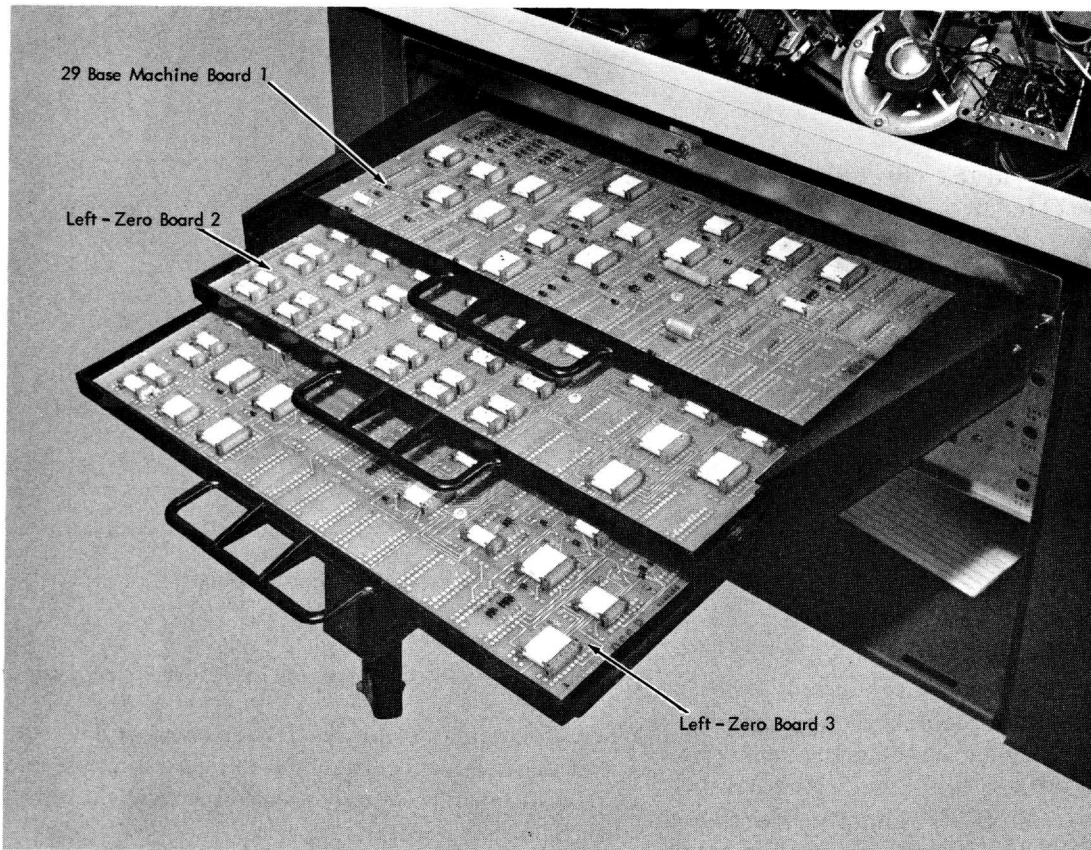

Figure 4-2. Left-Zero Relays (Reed Relay Machines)

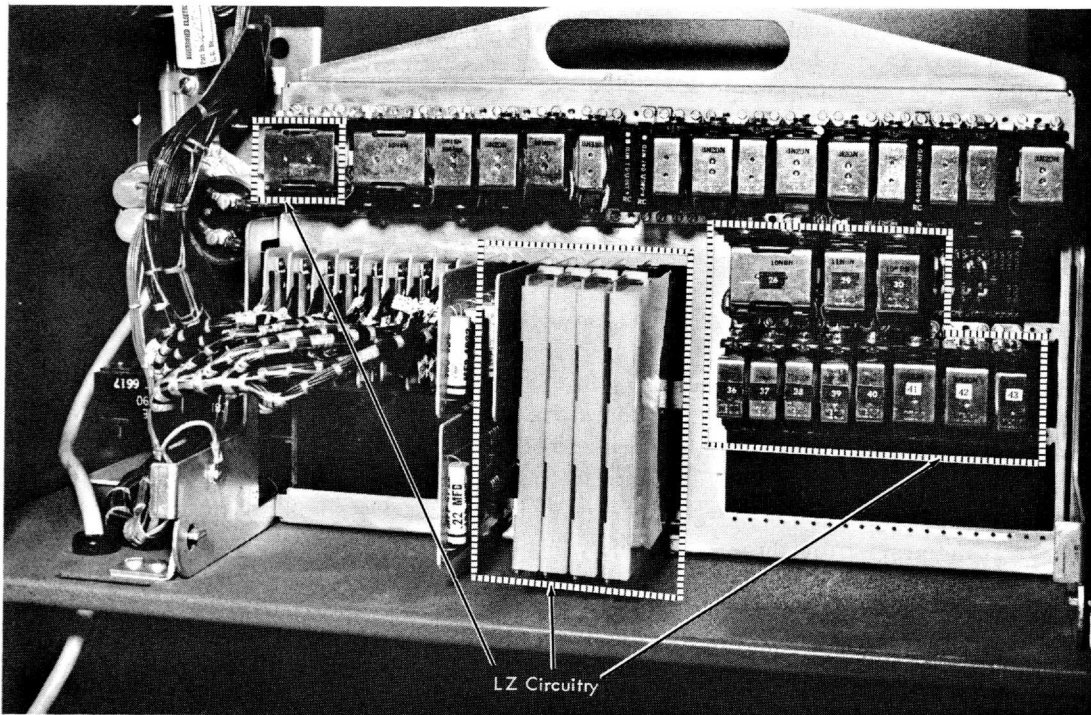

Figure 4-3. Left-Zero Relays (Wire Contact Relay Machines)

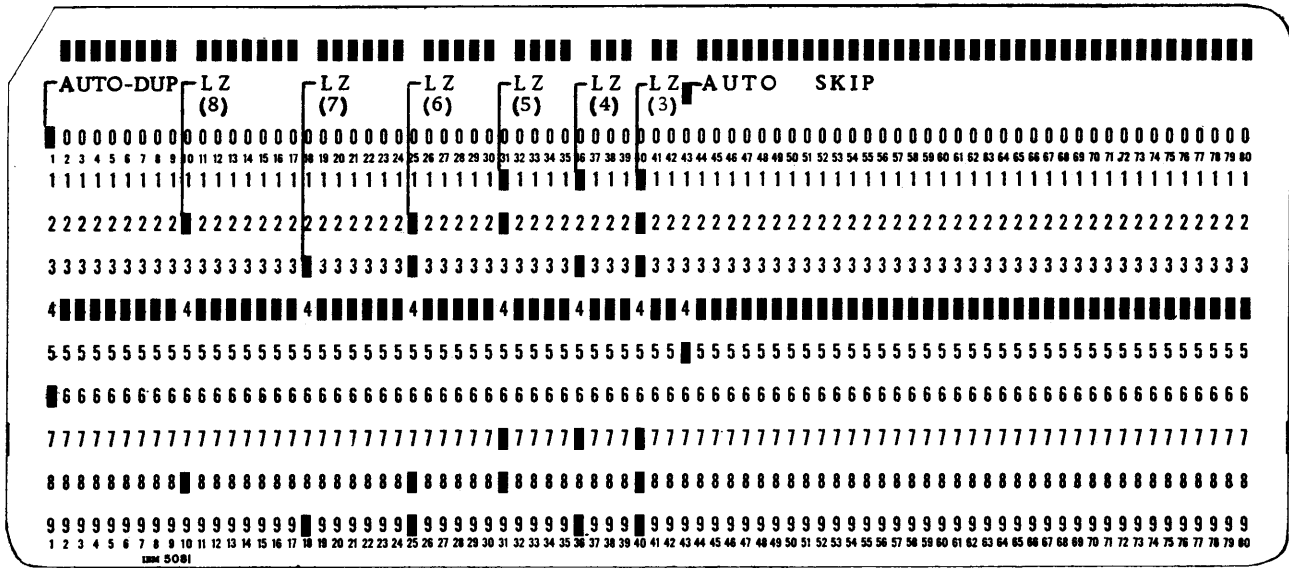

Figure 4-4. Left-Zero Program Card

- A punch clutch cycle without escapement or punching is necessary.
- The keyboard is restored.
- The first digit is stored in the eighth register.

Description

The machine is stopped at an eight-column left-zero field; the operator wishes to enter the correct digits before pressing the left-zero key. Escapement to the next column must be prevented until the left-zero key is pressed. A punch cycle is taken with each key depression. No information is entered into the interposers during the read in cycle; thus, there is no escapement. The punch clutch cycle during read-in is necessary only to use the P-cam timings for the left-zero operation.

To reduce the number of relays needed in each register to store the information as it is keyed, the decimal digits are converted into BCD (binary coded decimal) as shown in Figure 4-5.

Example: When the program card shown in Figure 4-4 is used, the machine is stopped at column 10 of the program card. The number to be keyed in this example is 46078 (Figure 4-6).

Read In Cycles

Cycle 1: Figure 4-7 shows the read in and read out logic flow. Refer to Figure 4-8 for timing within cycles. The machine is stopped at the high-order position of the left-zero field. Starwheel 2 is sensed and the left-zero field relays 1, 2, and 3 and the key entry relay are energized. The field and field size relays transfer

Decimal	1	2	3	4	5	6	7	8	9
BCD	1	2	1-2	4	1-4	2-4	1-2-4	8	1-8

Figure 4-5. BCD Code

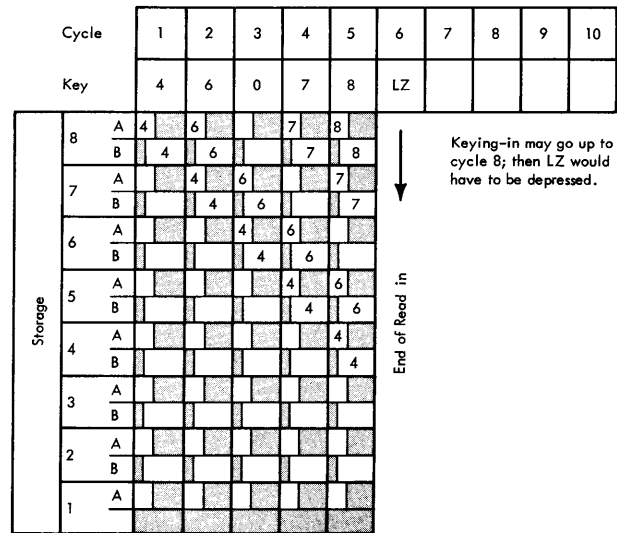

NOTE: Card remains in program column 10 throughout read in.

Figure 4-6. Read In (46078)

the keyboard latch contacts from the interposer magnets to the left-zero register, and allow entry of data into the registers.

The operator presses the correct key, closing the latch contact, and energizing the relays of the 8A register and the punch clutch. The punch clutch cir-

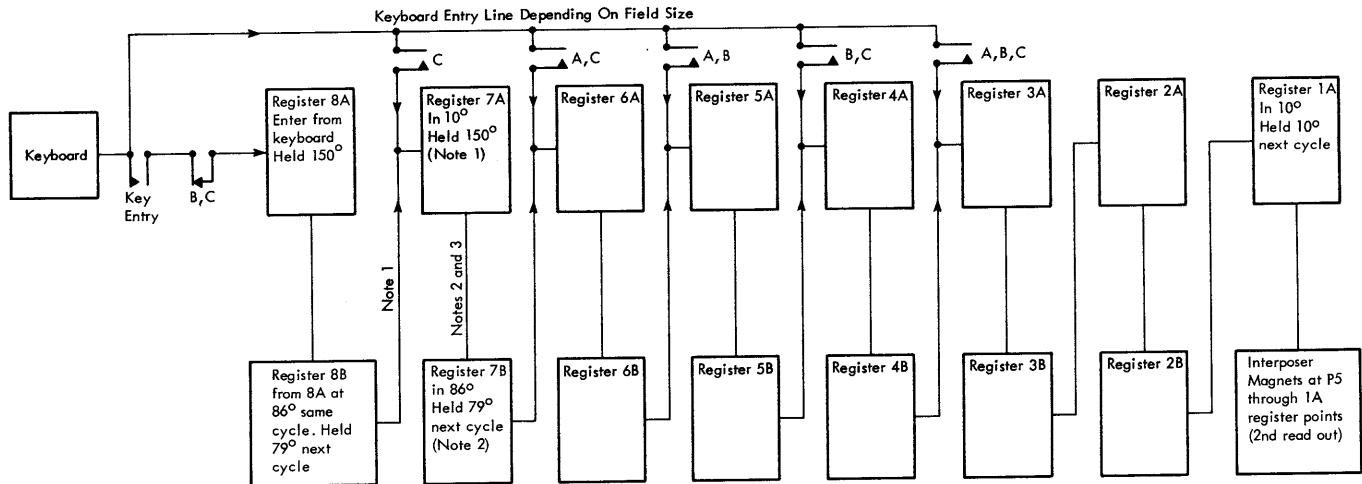

NOTE 1: Information transfers from B registers to A registers at 10°.
 NOTE 2: Information transfers from A registers to B registers at 86°.

Figure 4-7. Read In and Read Out Logic Flow

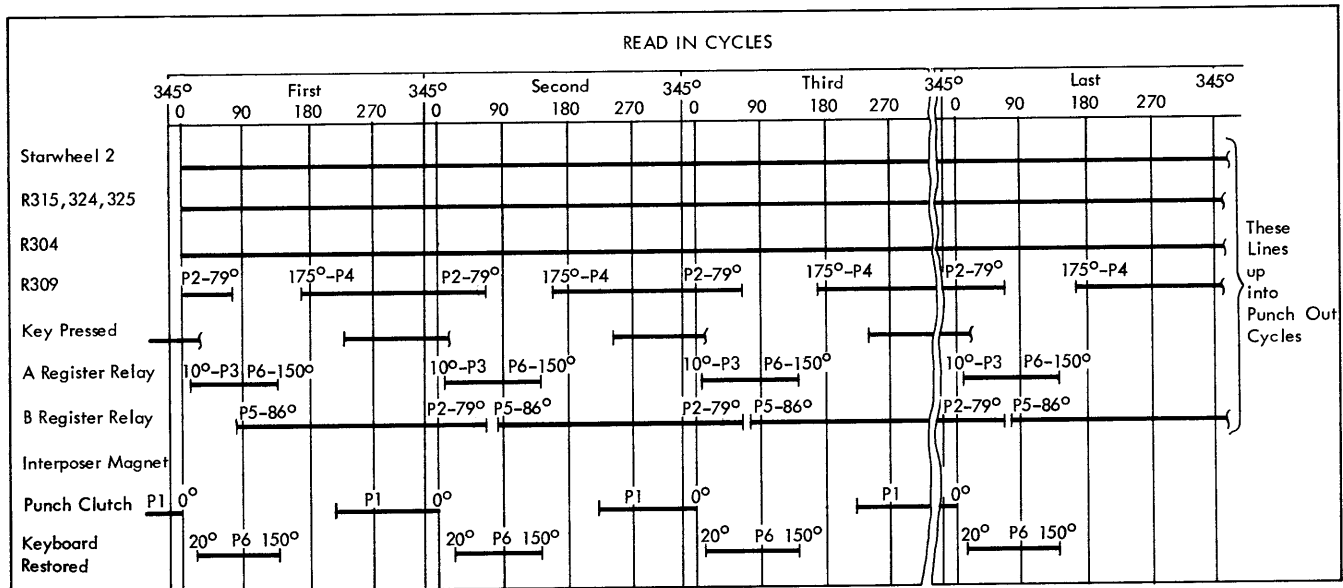

Figure 4-8. Read In Timing

cuit is opened by P1 at 0°. At 20° P6 makes, energizing the keyboard restore magnets. (P-cam-gate relay was energized at 175° by P4 in the previous cycle and is held until 79° of this cycle by P2.) When P5 makes at 86°, the correct 8B relays are picked and the information is transferred from the 8A register to the 8B register. (The 8A relays are held until 150° by P6. The 8B relays are held until 79° of the next cycle by P2.)

Field size relays are energized by the starwheels at the same time as field 1, 2, and 3 relays. The field size relays allow the data to enter registers 8A, 7A, 6A, 5A, 4A, or 3A from the keyboard. *In this example*, a 4 is stored in the 8B register (Figure 4-7).

Cycle 2: The machine is still in the high-order column, field 1, 2, and 3 relays and the key entry relay are picked.

The operator presses the next key, which closes the latch contact, and energizes the punch clutch and the correct 8A register relays. At 10° P3 makes, and the information in register 8B is transferred to register 7A. When P6 makes at 20°, the keyboard is restored. At 86° P5 makes, and the information in registers 8A and 7A is transferred to registers 8B and 7B. (Registers 8A and 7A are held until 150° by P6. Registers 8B and 7B are held by P2 until 79° of the next cycle.) *In this example*, a 6 is entered into register 8A. The 4 in

register 8B is transferred to register 7A at 10° by P3. At 86°, the 6 in 8A and the 4 in 7A transfer to 8B and 7B, respectively.

Cycle 3: A punch clutch cycle is taken. The previously entered information is transferred to the next A registers at 10°. The information is then transferred to the B registers at 86°. *In this example*, the operator presses the zero key, which closes the latch contact, and energizes the punch clutch through a N/O point of the key entry relay. Nothing is entered in register 8A, because nothing (no relays picked) in a register represents a zero during the punch out cycle. Information in the B registers transfers at 10° to the next A registers (Figures 4-7, 4-8). At 86°, the information is transferred to the B registers. At the end of this cycle, there is a 0 in 8B, a 6 in 7B, and a 4 in 6B.

Cycle 4: The 7-latch contact enters a 7 into register 8A. The previously entered information transfers to registers 7A, 6A, and 5A at 10°. The keyboard is restored by P6 at 20°. The information in the A registers is transferred to the B registers at 86°. (Register 8A is held until 150° by P6; 8B is held until 79° of the next cycle by P2.) *In this example*, the 7 key is pressed, which closes the latch contact. At the end of the cycle there is a 7 in 8B, a 0 in 7B, a 6 in 6B, and a 4 in 5B.

Cycle 5: An 8 is entered into register 8A. At 10°, the information in the B registers is transferred to the next A registers. The keyboard is restored at 20°. At 86°, the information in the A registers is transferred to the B registers. (The information in the B registers is retained until 79° of the next cycle.) *In this example*, the operator has keyed the number 46078. The B registers, at the end of the cycle, have stored an 8 in 8B, 7 in 7B, 0 in 6B, 6 in 5B, and 4 in 4B. Because registers 3B and 2B do not have any relays energized, they equal zero. All A registers equal zero.

Circuit Objectives

1. Cycle 1 (store a 4):
 - Close numeric-4 latch contact. (1A)
 - Enter numeric information into register 8A and energize the punch clutch. (12A, 21B, 22A)
 - Restore the keyboard. (18B)
 - Transfer register 8A to 8B. (25)
 - Retain information in register 8B.
2. Cycle 2 (store a 6):
 - Close numeric-6 latch contact. (1B)
 - Enter numeric information into register 8A and energize the punch clutch.
 - Transfer information from register 8B to 7A. (26A)
 - Restore the keyboard.
 - Transfer registers 8A and 7A to 8B and 7B. (25, 26)

- Retain information in registers 8B and 7B.
3. Cycle 3 (store a 0):
 - Close numeric-0 latch contact. (1A)
 - Enter numeric information into register 8A and energize the punch clutch.
 - Transfer registers 8B and 7B to 7A and 6A.
 - Restore the keyboard.
 - Transfer information from registers 8A, 7A, and 6A to 8B, 7B, and 6B.
 - Retain information in registers 8B, 7B, and 6B.
 4. Cycle 4 (store a 7):
 - Close numeric-7 latch contact. (1B)
 - Enter numeric information into register 8A and energize the punch clutch.
 - Transfer registers 8B, 7B, and 6B to 7A, 6A, and 5A.
 - Restore the keyboard. (8B, 18B)
 - Transfer information from registers 8A, 7A, 6A, and 5A to 8B, 7B, 6B and 5B.
 - Retain information in registers 8B, 7B, 6B, and 5B.
 5. Cycle 5 (store an 8):
 - Close numeric-8 latch contact. (1B)
 - Enter numeric information into register 8A and energize the punch clutch. (25A)
 - Transfer registers 8B, 7B, 6B, and 5B to 7A, 6A, 5A, and 4A.
 - Restore the keyboard.
 - Transfer information from registers 8A, 7A, 6A, 5A, and 4A to 8B, 7B, 6B, 5B and 4B.
 - Retain information in registers 8B, 7B, 6B, 5B, and 4B.

Read Out, Punch Out

- Read out the stored information.
- Set up the interposer magnets.
- Energize the escape and punch clutch magnets.
- Punch the information into the card.

Description

The punch out of a left-zero field is like an auto duplication operation; a punch cycle must be taken without an escapement to start the punch out. During the time that P5 is made, the information in the first register is read into the interposers. Information in the interposers causes the first escapement and the next punch cycle.

Preventing the transfer of information stored in the register for the first cycle (dummy cycle), allows the first register to be read and cleared. As each column is punched, the information is transferred from register to register. The transfer allows the information that is to be punched to be in register 1A at P5 time

of each punch cycle. The information is stored in BCD and converted to decimal form before reaching the interposer magnets by using register 1A relays to form a decode tree.

Read Out, Punch Out Cycles

Cycle 1: Refer to Figure 4-9 for timing within cycles. The operator presses the left-zero key, closing the left-zero latch contact, and energizing the read out relay and the punch clutch.

The left-zero field 1, 2, and 3 relays, and the key entry relay are held by starwheel 2. (P-cam-gate relay was picked at 175° of the last cycle by P4.) Information is normally transferred from the B registers to the A registers at 10° when P3 makes; for this cycle, the P3 pulse is prevented from going to the registers by N/C points of the read out relay.

Because no transfer occurs, the information is held in the B registers and the 1A register for this first cycle by the N/O points of the read out relay and starwheel 2. By the time an escapement occurs, starwheel 2 and P2 make, holding the B register. P7 is also made. (P6 or P7 is the hold for the 1A register. P7 is used as a continuing hold to register 1A; if P6 released the 1A register at 150°, the 1A relay points would open the interposer magnets circuit.) The keyboard is restored

at 20° by P6, and is held restored by a N/O point of the punch out relay to +48 volts for the rest of the left-zero field.

At P5 time (86°), the interposer magnets are energized through a N/O point of the read out relay and the decode tree of register 1A relay points. (The read out relay and 1A register energize the 0 interposer magnet, when the condition of no relays picked exists for the next punch operation.)

The punch out relay is picked by P5 through a N/O point of the read out relay. When starwheel 2 opens, the key entry relay, and field 1, 2, and 3 relays are de-energized. The escape magnet is energized by the interposer bail contacts and P1 (180°). The escape armature contact makes, energizing the escape interlock relays, and allowing the punch clutch to be energized for the next cycle. *In this example*, during the cycle, the 0 interposer magnet is energized and escapement to column 10 occurs.

Cycle 2: During this cycle, the information that was transferred from register 1A to the interposer magnet during the previous cycle is punched. The information transfers from register to register and energizes the interposer magnet for the digit to be punched during the next cycle. The punch clutch will not latch up for the rest of the left-zero field.

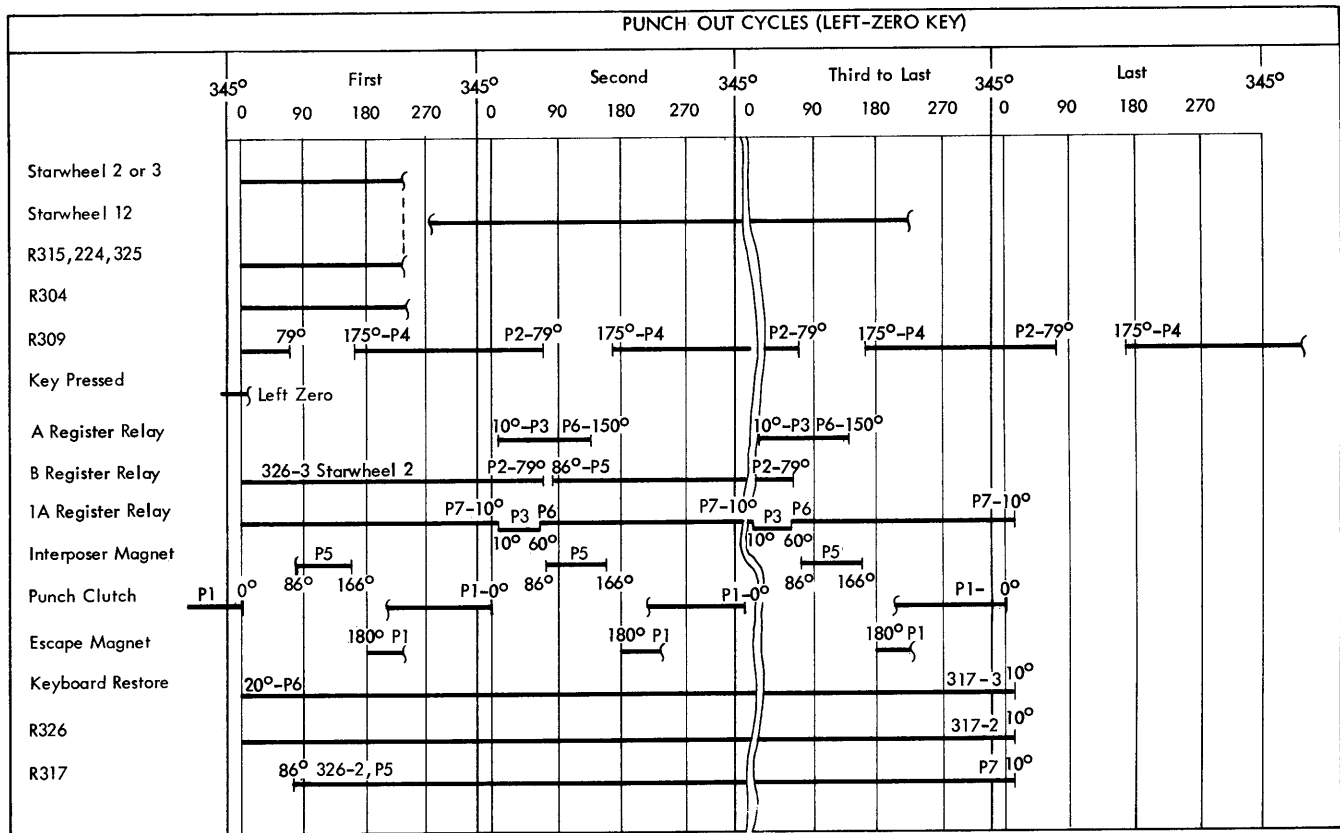

Figure 4-9. Punch Out Timing (8-Column Field)

At 10°, the information in the B registers is transferred to the next A registers (Figure 4-9). The transfer of information from the registers on this cycle and the rest of the punch out cycles is allowed to occur through a N/O point of the P-cam-gate relay, the punch out relay, and P3.

At P5 time, the interposer magnet is energized through the decode tree. The interposer bail contacts close, energizing the escape magnet. The escape armature contact energizes the escape interlock relays. The punch clutch is energized through P1, the escape interlock points, and P2. At 86° (P5), the information in registers 8A through 2A is transferred to registers 8B through 2B. (The A registers are held until 150° by P6. The 1A register is held until 10° of next cycle by P7. The information in the B registers is retained until 79° of the next cycle.) *In this example*, the 0 interposer magnet is energized, a 0 is punched in column 10, and an escapement to column 11 occurs.

Cycle 3: During this cycle, information that was set up in the last cycle is punched, new information transfers to the interposers, a new column escapement occurs, and a punch clutch cycle is initiated. At 10°, the information is transferred from registers 8A through 2A to registers 8B through 2B, and the interposer magnet is energized through the decode tree. (The A registers are held until 150°.) The escape magnet is energized by closing the interposer bail contacts; the escape armature contact energizes the escape interlock relays. The punch clutch is energized through P1, the escape interlock relays, and P2. *In this example*, a 0 is punched in card column 11, the 0 interposer magnet is energized, escapement to column 12 occurs, and the punch clutch is energized.

Cycles 4, 5, 6, and 7: Cycles 4, 5, 6, and 7 are identical to cycle 3 in operation. *In this example*, a 0 is punched in column 12, the 4 interposer magnet is energized, and escapement to column 13 occurs during cycle 4. Cycle 5 punches a 4, energizes the 6 interposer magnet, and escapes to column 14. Cycle 6 punches a 6 in column 14, energizes the 0 interposer magnet, and escapes to column 15. Cycle 7 punches a 0 in column 15, energizes the 7 interposer magnet, and escapes to column 16.

Cycle 8: During this cycle, the information set up in cycle 7 is punched. The last digit is transferred from register 2B to register 1A. The interposer magnet is energized to allow the last digit to be punched on the next cycle. At 10°, the information in register 2B is transferred to register 1A. At 86°, the information in registers 8A through 2A is transferred to registers 8B through 2B, and the interposer magnet is energized through the decode tree. The interposer bail contacts make, energizing the escape magnet at 180° (P1);

the escape armature contact makes, energizing the escape interlock relays. The punch clutch is energized through P2, the interlock relays, and P1. All digits that were keyed in have been read out, so all registers equal 0 (no relays picked). *In this example*, cycle 8 punches a 7 in column 16, energizes the 8 interposer magnet, and escapes to column 17.

Cycle 9: Escapement to the last column of the field (detail card) and out of the last column of the field (program card) occur in the last part of cycle 8. The starwheel 12 contact opens. All digits have been read out of storage; the last digit is punched in this cycle. The left-zero control relays are dropped during this cycle. At 10°, the punch out relay is dropped; after starwheel 12 contact opens, the punch out relay is held by P7 until 10° of this cycle. The N/O points of the punch out relay open, dropping read out 1 relay. The N/O points of the punch out relay open the circuit to the keyboard restore magnets, but the interposer bail contacts hold the magnet until about 65°. The digit is punched and the punch clutch latches at 345°. *In this example*, column 17 is punched with an 8 (Figure 4-10).

Circuit Objectives

1. Cycle 1 (energize 0 interposer magnet) (2A, 24A):

Close left-zero latch contact. (19A)

Cycle	Read in Last Key	1	2	3	4	5	6	7	8	9
Key	8	LZ								
8	A 8 B 8									
7	A 7 B 7									
6	A 6 B 6									
5	A 6 B 6									
4	A 4 B 4									
3	A 4 B 4									
2	A 4 B 4									
1	A									
Interposer		0	0	0	4	6	0	7	8	
Punch		Dummy	0	0	0	4	6	0	7	8
Detail Card Column	9	9	10	11	12	13	14	15	16	17
Program Card Column	10	10	11	12	13	14	15	16	17	18

← Dummy Punch Cycle

Figure 4-10. Punch Out (46078)

- Energize punch clutch and read out relay (326). (20A, 12A)
- Prevent transfer of information in registers. (326-3, 19B)
- Provide a hold on the information in registers. (326-5, 18A, 11A)
- Provide a special hold for register 1A. (18A)
- Provide a continuous restore to the keyboard. (18B)
- Energize interposer magnet. (23, 24)
- Energize punch out relay (317). (20A)
- Drop key entry (304) and field 1, 2, and 3 relays (315, 324, 325). (18A)
- Energize escape magnet. (9B, 10B)
- Energize escape interlock relays. (12A)
- Energize punch clutch. (12A)
- 2. Cycle 2 (punch a 0 and energize 0 interposer magnet):
 - Transfer B registers to next A registers.
 - Hold 1A register until 10° next cycle. (32B)
 - Transfer A registers to B registers.
 - Hold B register information until next cycle. (18A, 11A)
 - Energize interposer magnets. (23, 24)
 - Energize escape magnet. (9B, 10B)
 - Energize escape interlock relays. (12A)
 - Energize punch clutch. (12A)
- 3. Cycles 3, 4, 5, 6, and 7:
 - These cycles are similar to cycle 2.
- 4. Cycle 8 (punch a 7 in column 16 and energize 8 interposer magnet) (23, 24):
 - Transfer B registers to next A registers.
 - Hold register 1A information until 10° next cycle.
 - Energize escape magnet. (10B)
 - Energize escape interlock relays. (12A)
 - Energize punch clutch. (12A)
 - Break starwheel 12 or 4 contact.
- 5. Cycle 9 (punch an 8 in column 17):
 - Drop punch out relay (317). (20A)
 - Drop read out relay (326). (20A)
 - Open circuit to keyboard restore magnets. (317-3, 17B).

Left-Zero Credit Field

- **An 11-punch in the units position indicates a credit field.**

To indicate a credit field, the operator keys in the information just as in a debit field. To start the read out, punch out operation, the operator presses the dash (—) key instead of the left-zero key. Pressing the dash key causes a credit (11-punch) in the units column to be punched above the units digit.

Credit Read In

- **The program card coding indicates a left-zero field.**
- **The operator keys in the correct digits.**
- **The information is stored.**

Description

The program card is multipunched with a 7, 8, and 9 (program 2) in the high-order position, indicating a 3-column field; for example, column 40 (Figure 4-4). The rest of the field is punched with 4's defining the field. The operator keys in the correct number of digits, then presses the dash key to start the punch out, including an 11-punch over the digit in the units position. *In this example*, the operator keys in one digit (5), and presses the dash key to start punching.

Read In Cycle

Cycle 1: The machine is stopped at a left-zero field, and the program select relay is up. The 7, 8, and 9 starwheels energize the field 1, 2, and 3 relays, the field size relays and the key entry relay. The P-cam-gate relay is up.

The operator presses the correct key, closing a latch contact, and energizing the correct relays in register 3A (through the field size relay points and the encoding diodes). The punch clutch is energized through the key entry relay and encoding diodes. At 20° of the punch clutch cycle, the keyboard is restored. The correct relays in register 3B are energized at 86°, and the information is transferred from register 3A to register 3B. *In this example*, a 5 is stored in register 3B.

Circuit Objectives

1. Cycle 1 (store a 5):
 - Close numeric-5 latch contact. (1)
 - Enter numeric information into register 3A and energize the punch clutch.
 - Restore the keyboard. (8A)
 - Transfer register 3A to 3B.
 - Retain information in register 3B.

Credit Read Out, Punch Out

- **The operator presses the dash key for a credit field.**
- **The information is read out and punched.**
- **The units column is multipunched. (Credit X over units position.)**

Description

The operator presses the dash key, energizing the necessary relays to start the read out and punch out,

and also the relays to remember that this is a credit field. A dummy cycle must be taken first to read out the first digit to be punched. Each cycle will read out the next digit to be punched. When the end of the field is recognized, an extra cycle must be taken to punch the 11-punch. This cycle is a multipunch cycle to prevent escapement from the units position of the field.

Read Out, Punch Out Cycles

Cycle 1: Refer to Figure 4-11 for timing within cycles. The operator presses the dash key, which closes the dash latch contact, and energizes the credit field 1 relay, the read out relay, and the punch clutch. As soon as the credit field 1 relay is up, the credit field 2 relay is energized through N/O points of the credit field 1 relay. A N/C point of the read out relay prevents the transfer of information from register to register. The keyboard restore magnets are energized at 20° by P6 and are held energized for the rest of the punch out cycles. Information is held in the B registers by P2, starwheel 8, and a N/O point

of the read out relay. At 86° (P5), the punch out relay is picked through read out relay N/O points. The interposer magnet is energized through read out relay N/O points, and the decode tree of register 1A relay points. The escape magnet is energized at 180° by P1 and the interposer bail contacts. The escape armature contact makes, energizing the escape interlock relays, and allowing the punch clutch to be energized for the next cycle. *In this example*, the 0 interposer magnet is energized and an escapement to column 40 of the detail card occurs.

Cycle 2: During this cycle, the digit that was set up during the last cycle is punched. *In this example*, a 0 is punched in column 40, the 0 interposer magnet is energized, the digit 5 transfers from register 3 to register 2, and an escapement to column 41 of the detail card occurs.

Cycle 3: The digit that was set up in the last cycle is punched. At 10°, the B registers transfer to the next A registers. *In this example*, the digit 0 is punched in column 41, the 5 interposer magnet is energized, and an escapement to column 42 occurs.

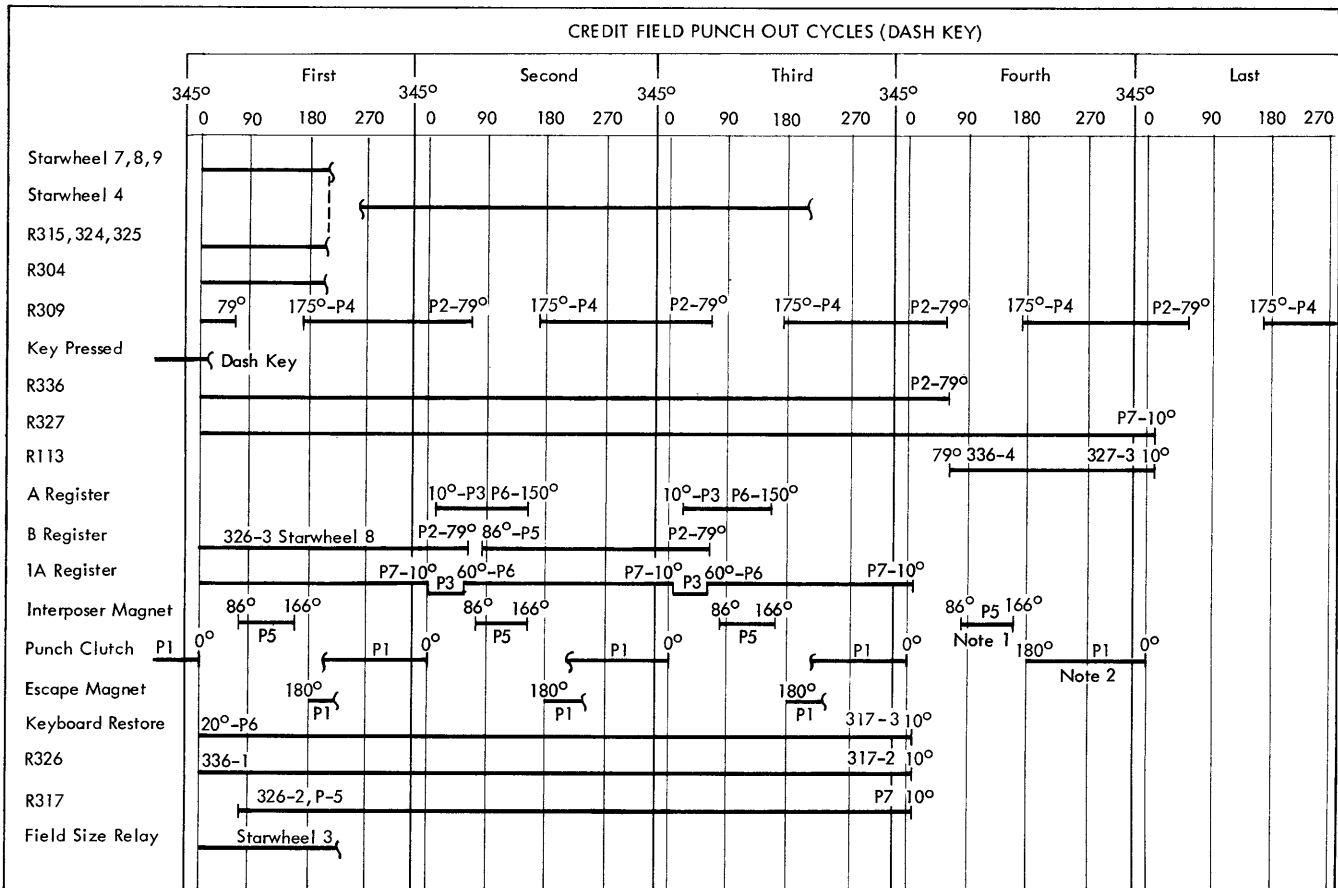

Note 1: The 11 Interposer Magnet
 Note 2: Punch Clutch Energized by Interposer Bail Contacts

Figure 4-11. Punch Out Timing (3-Column Credit Field)

Cycle 4: The last digit has been transferred from storage and is punched in this cycle. At 10°, the punch out relay is dropped. The opening of punch out relay N/O points drops the read out relay. At 79° (P2), credit field 1 relay drops. The multipunch relay is energized (through N/O points of the credit field 2 relay and N/C points of the read out relay) and prevents a circuit to the escape magnet when the 11 interposer magnet is energized. The 11 interposer magnet is energized at 86° (P5) through N/C points of the credit field 1 relay and N/O points of the credit field 2 relay. The punch clutch is energized through N/O points of the multipunch relay and the interposer bail contacts. *In this example*, a 5 is punched in column 42 and the 11 interposer magnet is energized.

Cycle 5: The credit 11 is punched during this cycle. At 10° (P7), the credit field 2 relay is dropped. N/O points of the credit field 2 relay open the circuit to the multipunch relay. The punch clutch latches at 345°. *In this example*, the 11-punch is punched above the 5 in column 42.

Circuit Objectives

1. Cycle 1 (energize 0 interposer magnet for punching in next cycle):

- Close dash latch contact. (11 key, 1A)
- Energize credit field 1 relay (336), read out relay (326), and punch clutch. (20A, 12A)
- Energize credit field 2 relay. (327). (20B)
- Prevent transfer of information in registers.
- Provide hold on the B registers and register 1A.
- Provide a continuous hold on restore magnets.
- Energize 0 interposer magnet.
- Energize the punch out relay. (317). (20A)
- Drop key entry relay (304) and fields 1, 2, and 3 relays (315, 324, 325). (18A)
- Energize escape magnet. (10B)
- Energize escape interlock relays. (131, WCR1). (12A)

2. Cycle 2 (punch a 0, energize 0 interposer magnet):

- Transfer B registers to next A registers.
- Hold register 1A until 10° of next cycle.
- Transfer A registers to B registers.
- Hold B register information until next cycle.
- Energize 0 interposer magnet.
- Energize escape magnet.
- Energize escape interlock relays. (131, WCR1)
- Energize punch clutch.

3. Cycle 3 (punch a 0, energize 5 interposer magnet):

- Transfer B registers to next A registers.
- Hold register 1A information until 10° next cycle.
- Transfer A registers to B registers.
- Hold B register until next cycle.

- Energize 5 interposer magnet.
- Energize escape magnet.
- Energize escape interlock relays.
- Energize punch clutch.
- Break starwheel 4 contact.

4. Cycle 4 (punch a 5, energize 11 interposer magnet):

- Drop punch out relay. (317). (20A)
- Drop read out relay. (326). (20A)
- Open circuit to keyboard restore magnets.
- Drop credit field 1 relay. (336). (20A)
- Energize the multipunch relay. (113). (6A)
- Prevent energizing the escape magnet.
- Energize 11 interposer magnet.
- Energize the punch clutch.

5. Cycle 5 (punch an 11 above the 5):

- Drop credit field 2 relay. (327). (20B)
- Drop multipunch relay. (113). (6A)

Left-Zero Logic Controls

Figure 4-12 is a diagram of the basic left-zero operations and their controls. The read in operations are shown with solid lines. The diagram can be used for both troubleshooting and a quick reference to general operation.

Principles of Operation for Wire Contact Relay Machines

- **Key the significant number.**
- **Make corrections before the field is punched.**
- **Press the left-zero key or dash key.**

When the program card shown in Figure 4-13 is used, the machine stops in the high-order column of the left-zero field.

The operator can key any number of significant digits. If the operator keys more digits than the field will hold, the first digits keyed will be accumulated in the 1A register and incorrect information may be punched out.

Read In

- **The program card coding (Figure 4-13) indicates a left-zero field.**
- **The operator presses the first digit key.**
- **A punch clutch cycle without escapement or punching is necessary.**
- **The keyboard is restored.**
- **The first digit is stored in the eighth register.**

Figure 4-12. Left-Zero Logic Controls and Flow

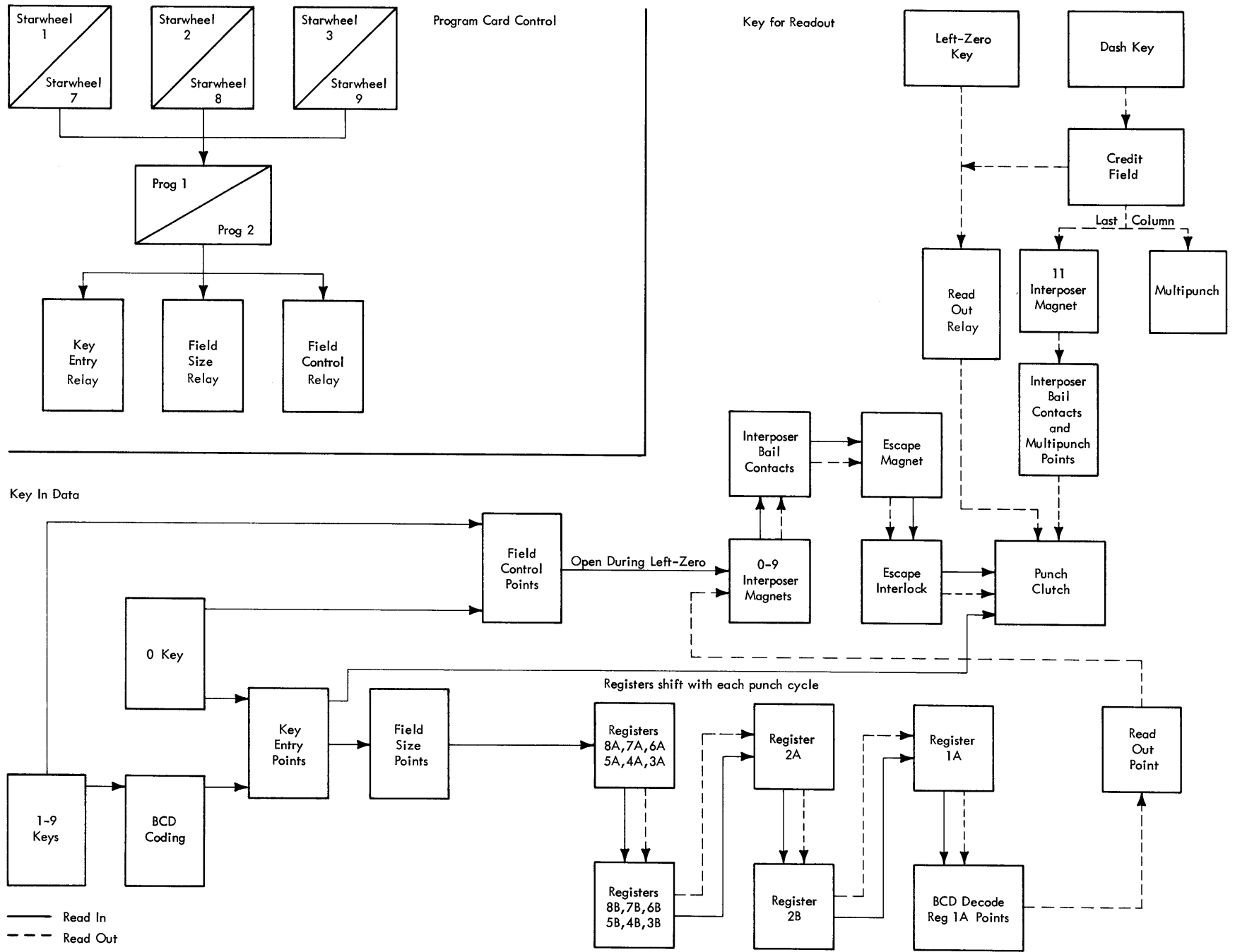

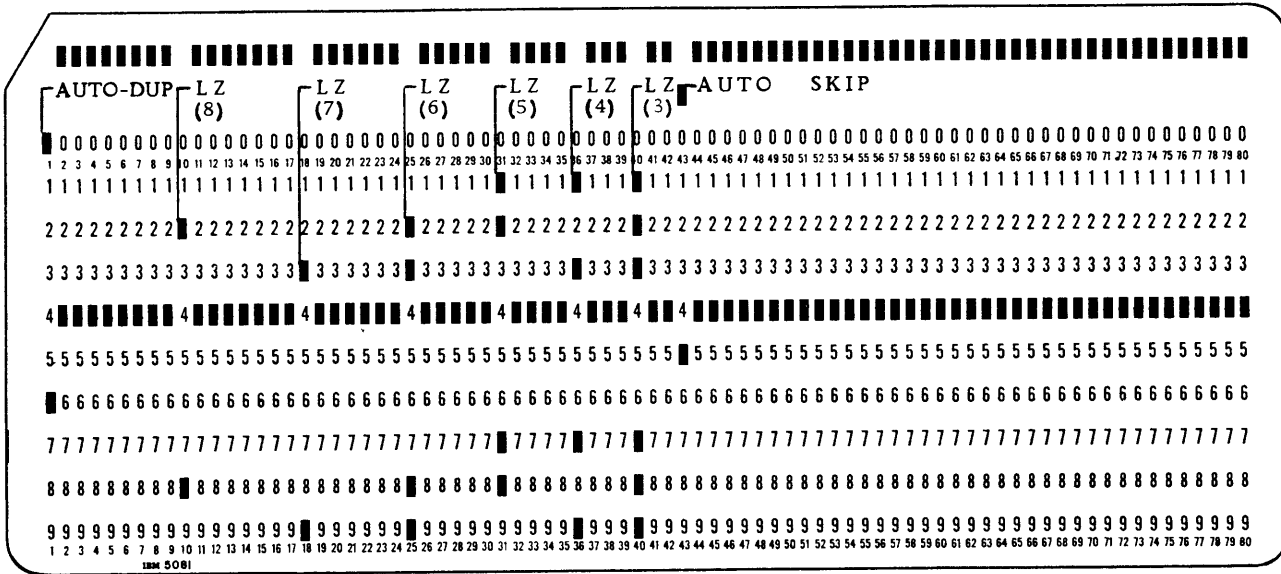

Figure 4-13. Left-Zero Program Card, Wire Contact Relay Machines

Description

The machine is stopped at an eight-column left-zero field; the operator wishes to enter the correct digits before pressing the left-zero key. Escapement to the next column must be prevented until the left-zero key is pressed. A punch cycle is taken with each key depression. No information is entered into the interposers during the read in cycle; thus there is no escapement. During read in, the punch clutch cycle is necessary only to use the P-cam timings for the left-zero operation.

To reduce the number of relays needed in each register to store the information as it is keyed, the decimal digits are converted into BCD (binary coded decimal) as shown in Figure 4-14. When the program card shown in Figure 4-13 is used, the machine is stopped at column 10 of the program card. The number to be keyed in this example is 46078 (Figure 4-15).

Read In Cycles (Read Relay A Registers)

Cycle 1: Figure 4-16 is the read in and read out logic flow. Refer to Figure 4-17 for timing within cycles. The machine is stopped at the high-order position of the left-zero field. Starwheel 2 is sensed; left-zero field size 2, field 1, and field 2 relays are energized. The field 1 relay transfers the keyboard latch contacts from the interposer magnets to the left-zero register (via the encoding circuit) and allows entry of data into the proper bit register.

The operator presses the correct key, which closes the latch contact, and energizes the 8A register relays and the punch clutch. The punch clutch circuit is opened by P1 at 0°. At 45° P6 makes, energizing the keyboard restore magnets through field 2 relay N/O

Decimal	1	2	3	4	5	6	7	8	9
BCD	1	2	1-2	4	1-4	2-4	1-2-4	8	1-8

Figure 4-14. BCD Code, Wire Contact Relay Machines

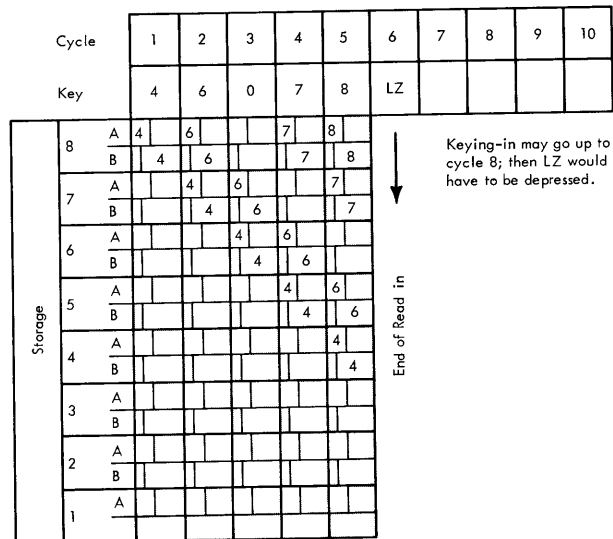

NOTE: Card remains in program column 10 throughout read in.

Figure 4-15. Read In (46078), Wire Contact Relay Machines

points. When P5 makes at 86°, the 8B relays are picked and the information is transferred from register 8A to register 8B. (The 8A register relays are held until 175° by P6; 8B is held by P2 until 65° of the next cycle.)

Field size relays are energized by the starwheels under control of the program card. The field size re-

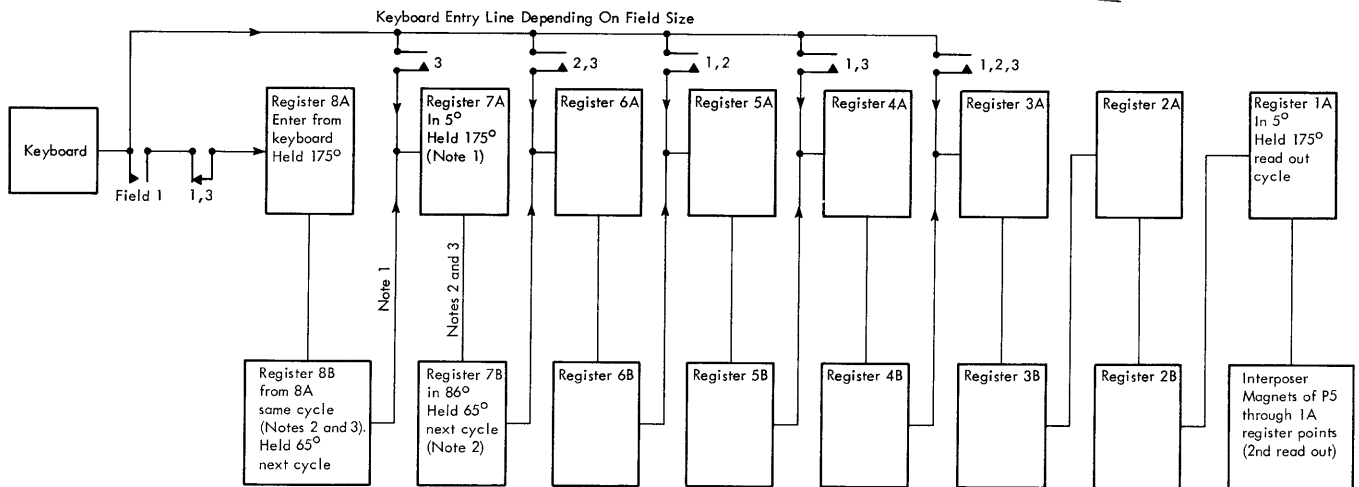

NOTE 1: Information transfers from B registers to A registers at 5°.
 NOTE 2: Information transfers from A registers to B registers at 86° (read-relay A registers).
 NOTE 3: Information transfers from A registers to B registers at 180° (capacitor A registers).

Figure 4-16. Read In and Read Out Logic Flow, Wire Contact Relay Machines

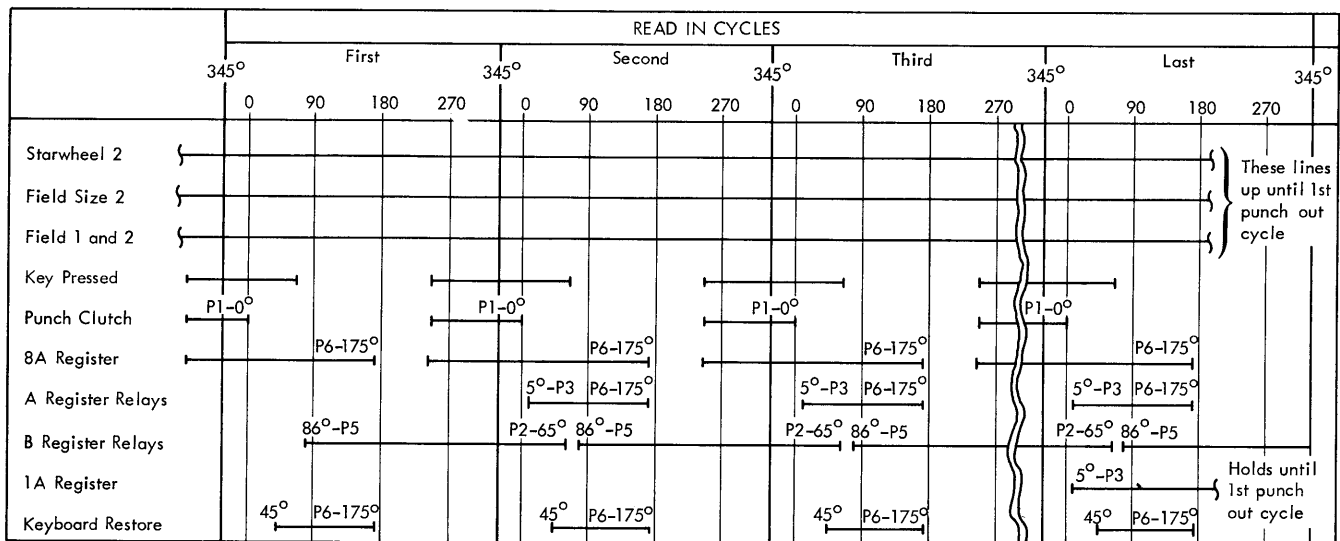

Figure 4-17. Read In Timing, Wire Contact Relay Machines (Reed Relay A Registers)

lays allow data to enter registers 8A, 7A, 6A, 5A, 4A, or 3A from the keyboard. *In this example*, a 4 is stored in register 8B (Figure 4-15).

Cycle 2: The machine is still in the high-order column, field 1 and 2, and field size 2 relays are picked.

The operator presses the next key, which closes the latch contact, and energizes the punch clutch and the 8A register relays. At 5° P3 makes, and the information in register 8B is transferred to register 7A. At 45° P6 makes, restoring the keyboard. When P5 makes at 86°, the information in registers 8A and 7A is transferred to registers 8B and 7B, respectively. (Registers 8A and 7A are held by P6 until 175°; 8B and 7B are held by P2 until 65° of the next cycle.)

In this example, a 6 is entered into register 8A. The 4 in register 8B is transferred to 7A at 5°. At 86°, the 6 in 8A and the 4 in 7A are transferred to 8B and 7B.

Cycle 3: A punch clutch cycle is taken. The previously entered information transfers to the next A registers at 5°. At 86°, information is transferred from the A registers to the B registers. *In this example*, the operator presses the 0 key, which closes the latch contact, and energizes the punch clutch. Nothing is entered into 8A (no relays picked in a register represents a 0 during a punch out cycle). At 5°, the B registers transfer to the next A registers. At 86°, the A registers transfer to the B registers. At the end of this cycle, there is a 0 in 8B, a 6 in 7B, and a 4 in 6B.

Cycle 4: The 7-latch contact enters a 7 into register 8A. The previously entered information is transferred from the B registers to the next A registers at 5°. At 45°, the keyboard is restored by P6. At 86°, P5 makes and transfers the information from the A registers to the B registers. *In this example*, the 7 key is pressed, which closes the latch contact. At the end of the cycle, there is a 7 in 8B, a 0 in 7B, a 6 in 6B, and a 4 in 5B.

Cycle 5: An 8 is entered into register 8A. At 5°, the B registers transfer information to the next A registers. At 45°, the keyboard is restored. When P5 makes at 86°, the A registers transfer to the B registers. *In this example*, the operator has keyed in the number 46078. At the end of the cycle, there is an 8 in 8B, 7 in 7B, 0 in 6B, 6 in 5B, and 4 in 4B. Because there are no relays energized in registers 3B and 2B, they equal 0. All A registers equal zero.

Circuit Objectives

1. Cycle 1 (store a 4):
 - Close numeric-4 latch contact. (1A)
 - Enter numeric information into register 8A and energize the punch clutch.
 - Restore the keyboard. (10B)
 - Transfer register 8A to 8B. (17, 18)
 - Retain information in register 8B.
2. Cycle 2 (store a 6):
 - Close numeric-6 latch contact. (1A)
 - Enter numeric information into register 8A and energize the punch clutch.
 - Transfer information from register 8B to 7A. (17, 18)
 - Restore the keyboard.
 - Transfer registers 8A and 7A to 8B and 7B (17, 18)
 - Retain information in registers 8B and 7B.
3. Cycle 3 (store a 0):
 - Close numeric-0 latch contact. (1A)
 - Enter numeric information into register 8A and energize the punch clutch.
 - Transfer register 8B and 7B to 7A and 6A.
 - Restore the keyboard.
 - Transfer information from registers 8A, 7A, and 6A to 8B, 7B, and 6B.
 - Retain information in registers 8B, 7B, and 6B.
4. Cycle 4 (store a 7):
 - Close numeric-7 latch contact. (1B)
 - Enter numeric information into register 8A and energize the punch clutch.
 - Transfer registers 8B, 7B, and 6B to 7A, 6A, and 5A.
 - Restore the keyboard. (10B)
 - Transfer information from registers 8A, 7A, 6A, and 5A to 8B, 7B, 6B, and 5B.

Retain information in registers 8B, 7B, 6B, and 5B.

5. Cycle 5 (store an 8):
 - Close numeric-8 latch contact. (1B)
 - Enter numeric information into register 8A and energize the punch clutch. (17, 18)
 - Transfer registers 8B, 7B, 6B, and 5B to 7A, 6A, 5A, and 4A.
 - Restore the keyboard.
 - Transfer information from registers 8A, 7A, 6A, 5A, and 4A to 8B, 7B, 6B, 5B and 4B.
 - Retain information in registers 8B, 7B, 6B, 5B, and 4B.

Read In Cycles (Capacitor A Registers)

Cycle 1: Figure 4-16 is the read in and read out logic flow. Refer to Figure 4-18 for timing within cycles. The machine is stopped at the high-order position of the left-zero field. Starwheel 2 is sensed; left-zero field size 2, field 1, and field 2 relays are energized. The field 1 relay transfers the keyboard latch contacts from the interposer magnets to the left-zero register (via the encoding circuit) and allows entry of data into the proper bit register.

The operator presses the correct key, which closes the latch contact, and charges the 8A register capacitor and energizes the punch clutch. The punch clutch circuit is opened by P1 at 0°. At 45° P6 makes, energizing the keyboard restore magnets through field 2 relay N/O points and terminating the charge to the 8A register capacitor. When P1 makes at 180°, the 8B relays are picked by the discharge of the 8A register capacitor and the information is transferred to the 8B register. The 8B register relays are held through P2 until 65° of the next cycle. Key entry during A-to-B-register transfer is prevented by field and end discharge relays.

Field size relays are energized by the starwheels under control of the program card. The field size relays allow data to enter registers 8A, 7A, 6A, 5A, 4A, or 3A from the keyboard. *In this example*, a 4 is stored in register 8B (Figure 4-15).

Cycle 2: The machine is still in the high-order column, field 1 and 2, and field size 2 relays are picked.

The operator presses the next key, which closes the latch contact, and energizes the punch clutch and charges the 8A register capacitors. At 5° P3 makes, and the information in register 8B is transferred to register 7A. At 45° P6 makes, restoring the keyboard. When P1 makes at 180°, the information in registers 8A and 7A is transferred to registers 8B and 7B, respectively. (8B and 7B register relays are held through P2 until 65° of the next cycle.)

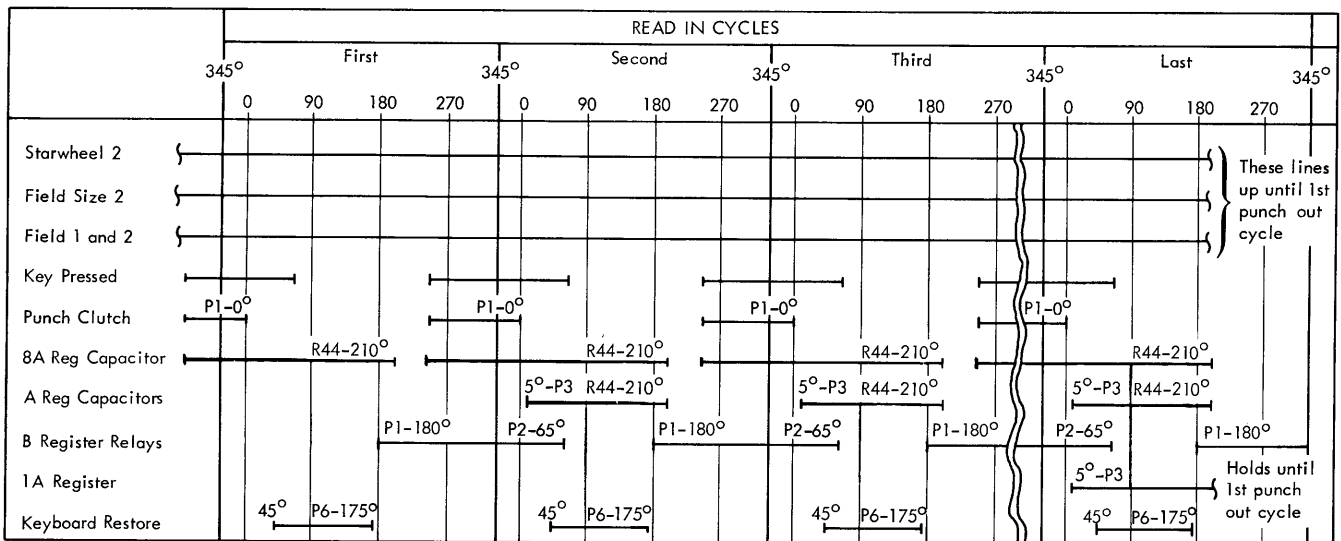

Figure 4-18. Read In Timing, Wire Contact Relay Machines (Capacitor A Registers)

In this example, a 6 is entered into register 8A. The 4 in register 8B is transferred to 7A at 5°. At 180°, the 6 in 8A and the 4 in 7A are transferred to 8B and 7B.

Cycle 3: A punch clutch cycle is taken. The previously entered information transfers to the next A register at 5°. At 180°, information is transferred from the A registers to the B registers. In this example, the operator presses the 0 key, which closes the latch contact, and energizes the punch clutch. Nothing is entered into 8A (no relays picked in a register represents a 0 during a punch out cycle). At 5°, the B registers transfer to the next A registers. At 180°, the A registers transfer to the B registers. At the end of this cycle, there is a 0 in 8B, a 6 in 7B, and a 4 in 6B.

Cycle 4: The 7-latch contact enters a 7 into register 8A. The previously entered information is transferred from the B registers to the next A registers at 5°. At 45°, the keyboard is restored through P6 and the capacitor charge is ended by the keyboard bail contacts opening. At 180°, P5 makes and transfers the information from the A registers to the B registers. In this example, the 7 key is pressed, which closes the latch contact. At the end of the cycle, there is a 7 in 8B, a 0 in 7B, a 6 in 6B, and a 4 in 5B.

Cycle 5: An 8 is entered into register 8A. At 5°, the B registers transfer information to the next A registers. At 45°, the keyboard is restored. When P1 makes at 180°, the A registers transfer to the B registers. In this example, the operator has keyed in the number 46078. At the end of the cycle, there is an 8 in 8B, a 7 in 7B, a 0 in 6B, a 6 in 5B, and a 4 in 4B. Because there are no relays energized in registers 3B and 2B, they equal 0.

Circuit Objectives

- Cycle 1 (store a 4):**
 Close numeric-4 latch contact. (1A)
 Charge numeric information into register 8A and energize the punch clutch.
 Restore the keyboard. (10B)
 Terminate capacitor charge.
 Transfer register 8A to 8B. (17, 18, 19, 20) Discharge capacitor through wcr-44 and P1.
 Allow key entry. (1A)
 Retain information in register 8B.
- Cycle 2 (store a 6):**
 Close numeric-6 latch contact. (1A)
 Charge numeric information into register 8A and energize the punch clutch.
 Transfer information from register 8B to 7A. (17, 18, 19, 20) Capacitor charges through P3 and 8B relay points.
 Restore the keyboard.
 Terminate capacitor charge.
 Transfer registers 8A and 7A to 8B and 7B. (17, 18, 19, 20)
 Allow key entry. (1A)
 Retain information in registers 8B and 7B.
- Cycle 3 (store a 0):**
 Close numeric-0 latch contact. (1A)
 Charge numeric information into register 8A and energize the punch clutch.
 Transfer registers 8B and 7B to 7A and 6A.
 Restore the keyboard.
 Terminate capacitor charge.
 Transfer information from registers 8A, 7A, and 6A to 8B, 7B, and 6B.

- Allow key entry. (1A)
 Retain information in registers 8B, 7B, and 6B.
4. Cycle 4 (store a 7):
 Close numeric-7 latch contact. (1B)
 Charge numeric information into register 8A and energize the punch clutch.
 Transfer registers 8B, 7B, and 6B to 7A, 6A, and 5A.
 Restore the keyboard. (10B)
 Terminate capacitor charge.
 Transfer information from registers 8A, 7A, 6A, and 5A to 8B, 7B, 6B, and 5B.
 Allow key entry. (1A)
 Retain information in registers 8B, 7B, 6B, and 5B.
5. Cycle 5 (store an 8):
 Close numeric-8 latch contact. (1B)
 Charge numeric information into register 8A and energize the punch clutch.
 Transfer registers 8B, 7B, 6B, and 5B to 7A, 6A, 5A, and 4A.
 Restore the keyboard.
 Terminate capacitor charge.
 Transfer information from registers 8A, 7A, 6A, 5A, and 4A to 8B, 7B, 6B, 5B, and 4B.
 Allow key entry. (1A)
 Retain information in registers 8B, 7B, 6B, 5B, and 4B.

Read Out, Punch Out

- Read out the stored information.
- Set up the interposer magnets.
- Energize the escape and punch clutch magnets.
- Punch the information into the card.

Description

This operation is initiated by pressing the left-zero (LZ) key. Unlike the operation for the reed relay machines, *no dummy cycle is taken*. The LZ key completes a circuit through the 1A register decode tree to the interposers. Information in the interposers causes the punch cycle; information is shifted to the A registers during P3 time and decoded to the interposers through 1A register at P5 time of each punch cycle. This information is stored in BCD and is converted into decimal form before reaching the interposer magnets by using the 1A register relays to form a decode tree.

Read Out, Punch Out Cycles

Cycle 1: Refer to Figure 4-19 or 4-20 for timing within cycles. The operator presses the left-zero key, which closes the left-zero latch contact and energizes the

read out relay and the first interposer magnet (through field 2 relay N/O points and the register 1A decode tree). The escape magnet is energized by the interposer bail contacts and there is an escapement to column 10. The escape armature contact makes, energizes the escape interlock relays and allows the punch clutch to be energized.

The left-zero field 1 and 2 relays are held by starwheel 2 through field size 2 relay N/O points until escapement occurs. When starwheel 2 opens, field size 2 relay and the field 1 and 2 relays are de-energized. At 5° when P3 makes, information is transferred from the B registers to the next A registers. The keyboard is restored by the interposer bail contacts and is held restored by P6 and N/O points of the read out relay to +48 volts.

At P5 time (86°), the read out interlock relay is picked, the A registers (capacitor A registers transfer at 180°) transfer to the B registers and the interposer magnets are energized (through N/O points of read out relay and the decode tree of register 1A relay points). The read out relay circuit energizes the 0 interposer magnet, when the condition of no relays picked exists, for the next punch operation.

The escape magnet is again energized by the interposer bail contacts and P1 (180°). The escape armature contact makes, energizing the escape interlock relays and allowing the punch clutch to be energized for the next cycle. *In this example*, the 0 interposer magnet is energized, a 0 is punched in column 10, and escapement to column 11 occurs.

Cycle 2: This cycle punches the information transferred from register 1A to the interposer magnet during the previous cycle. Information is transferred from register to register and the interposer is energized for the digit to be punched during the next cycle. (The punch clutch does not latch up for the rest of the left-zero field.)

At 5°, the information in the B registers is transferred to the next A registers (Figure 4-19 or 4-20). (Register 1A is held until 175° by P6.)

At P5 time (86°), the interposer magnet is energized through the decode tree. The interposer bail contacts close, energizing the escape magnet. The escape armature contact energizes the escape interlock relays (9,10). The punch clutch is energized through P1 and the escape interlock points. Information in the A registers (capacitor A registers transfer at 180°) is transferred to the B registers and retained there until 65° of the next cycle. *In this example*, cycle 2 energizes the 0 interposer magnet, punches a 0 in column 11, and escapes to column 12.

Cycle 3: This cycle punches the information that was set up in the previous cycle, transfers new infor-

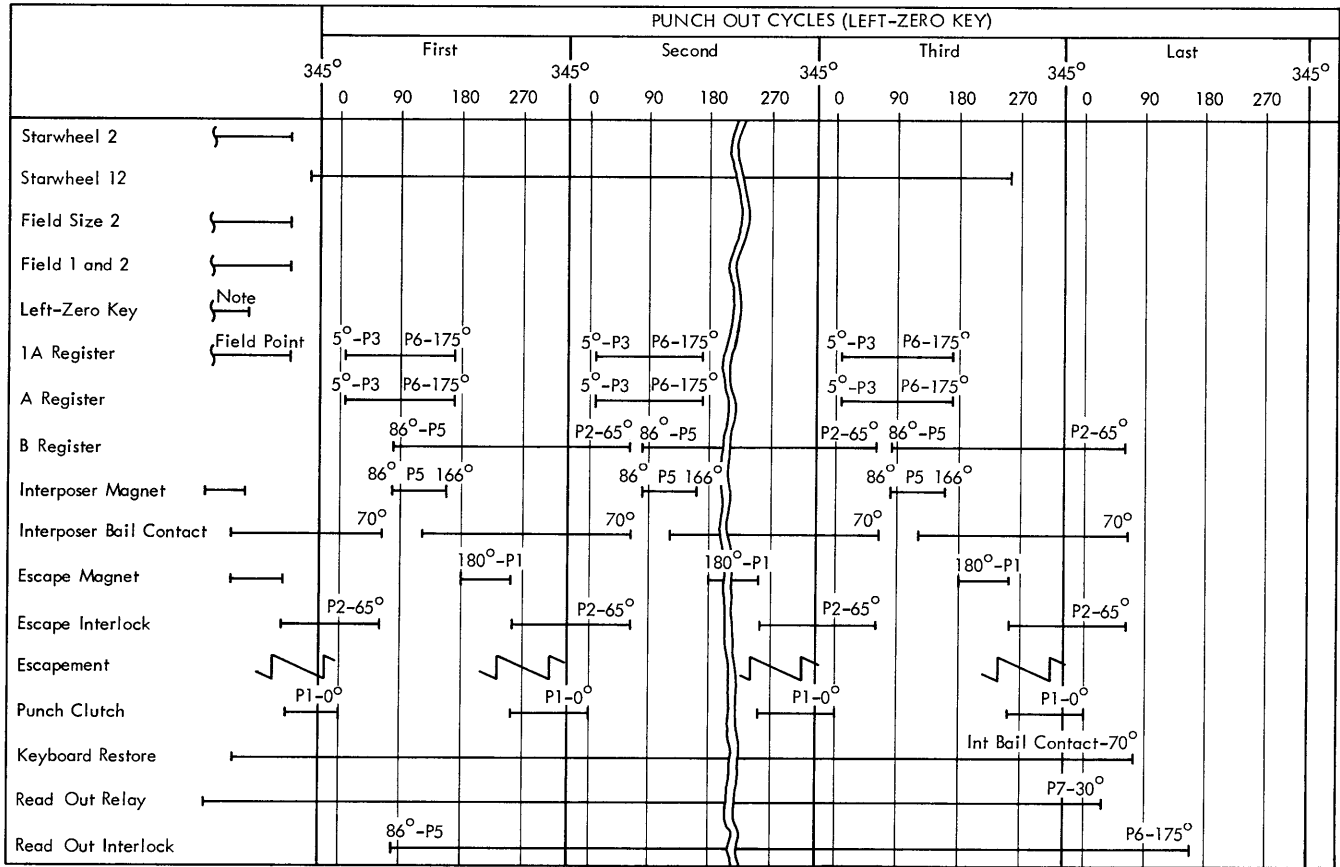

NOTE: The left-zero key picks the read out relay and the first interposer magnet to start the punch out operation.

Figure 4-19. Punch Out Timing (8-Column Field) Reed Relay A Registers, Wire Contact Relay Machines

mation to the interposers, escapes to the next column, and initiates a punch clutch cycle.

At 5°, information is transferred from the B registers to the next A registers. At 86°, the information is transferred from the A registers (capacitor A registers transfer at 180°) to the B registers and the interposer magnet is energized. The escape magnet is energized by the closing of the interposer bail contacts. The escape armature contact energizes the escape interlock relays. The punch clutch is energized through P1 and the escape interlock relays. *In this example*, a 0 is punched in card column 12, the 4 interposer magnet is energized, and escapement to column 13 occurs.

Cycles 4, 5, 6, and 7: Cycles 4, 5, 6, and 7 are similar to cycle 3 in operation. *In this example*, a 4 is punched in column 13, the 6 interposer magnet is energized, and escapement to column 14 occurs during cycle 4. Cycle 5 punches a 6 in column 14, energizes the 0 interposer magnet, and escapes to column 15. Cycle 6 punches a 0 in column 15, energizes the 7 interposer magnet, and escapes to column 16. Cycle

7 punches a 7 in column 16, energizes the 8 interposer magnet, and escapes to column 17.

Cycle 8: Escapement to the last column of the field (detail card) and out of the last column of the field (program card) occurs in the last part of cycle 7. The starwheel 12 contact opens. All digits have been read out of storage; the last digit is punched on this cycle. At 30°, the read out relay is dropped. (After starwheel 12 opens, the read out relay is held by P7 until this time.) N/O points of the read out relay open the circuit to the keyboard restore magnets, but the interposer bail contacts hold the magnets until about 65°. The digit is punched and the punch clutch latches at 345°. *In this example*, column 17 is punched with an 8 (Figure 4-21).

Circuit Objectives

1. Cycle 1 (energize 0 interposer magnet, punch a 0, re-energize 0 magnet):
Close left-zero latch contact. (16B)

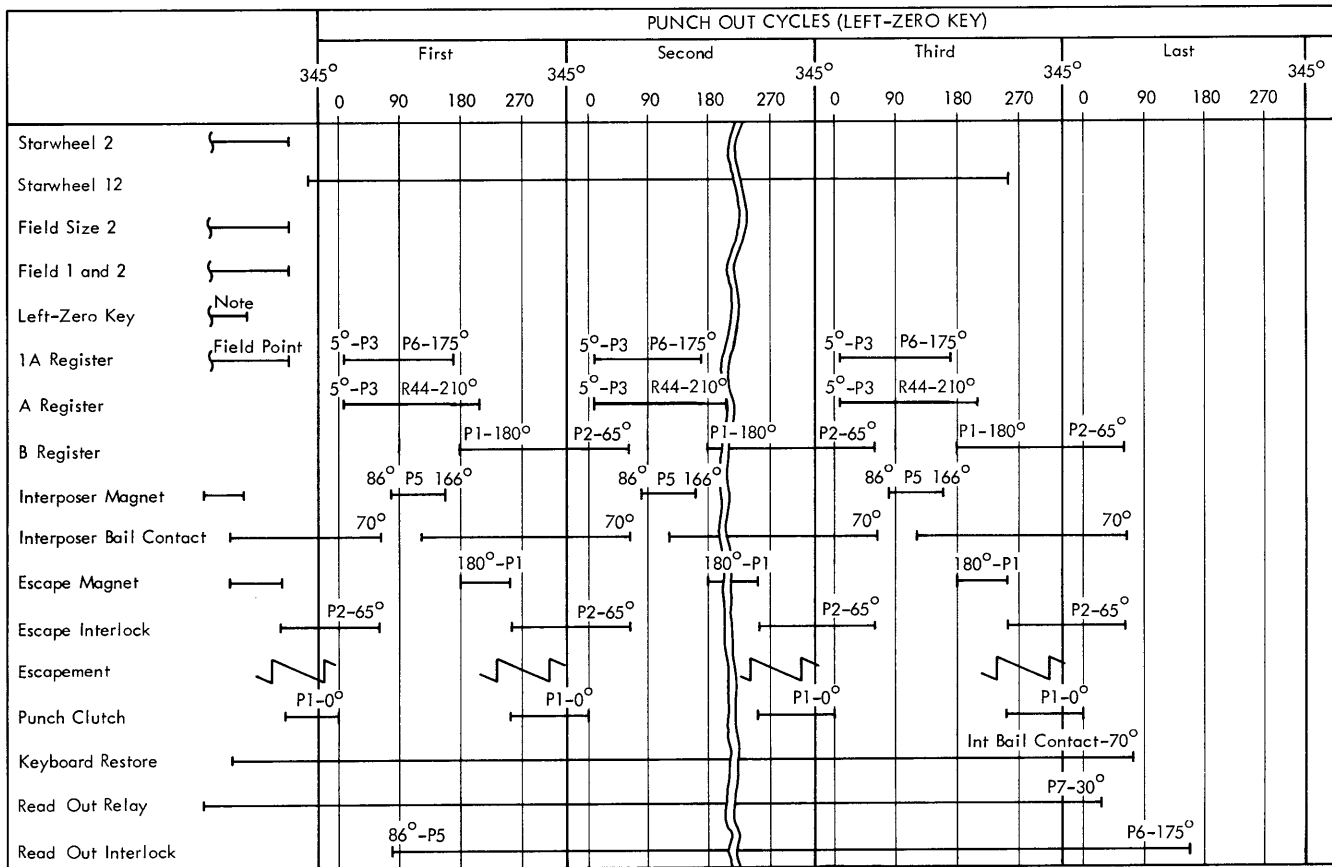

NOTE: The left-zero key picks the read out relay and the first interposer magnet to start the punch out operation.

Figure 4-20. Punch Out Timing (8-Column Field) Capacitor A Registers, Wire Contact Relay Machines

Cycle	Read in Last Key	1	2	3	4	5	6	7	8						
Key	8	LZ													
8	A 8														
	B 8														
7	A 7	8													
	B 7	8													
6	A 6		7	8											
	B 6		7	8											
5	A 5			6	7	8									
	B 5			6	7	8									
4	A 4				5	6	7	8							
	B 4				5	6	7	8							
3	A 3					4	5	6	7	8					
	B 3					4	5	6	7	8					
2	A 2						3	4	5	6	7	8			
	B 2						3	4	5	6	7	8			
1	A 1							1	2	3	4	5	6	7	8
Interposer		0	0	4	6	0	7	8							
Punch		0	0	0	4	6	0	7	8						
Detail Card Column	9	10	11	12	13	14	15	16	17						
Program Card Column	10	11	12	13	14	15	16	17	18						

- Energize read out relay (42), interposer magnet, and punch clutch. (16B, 2A, 10A)
 - Restore keyboard. (10B)
 - Transfer information from B register to next A register. (17, 18, 19, 20)
 - Drop field size 2 relay (29) and field 1 and 2 relays (1, 36). (14A)
 - Transfer A register to B register.
 - Energize interposer magnet. (2A)
 - Energize escape magnet. (12B)
 - Energize escape interlock relays. (9, 10). (10A)
 - Energize punch clutch. (10A)
2. Cycle 2 (punch a 0 and energize 0 interposer magnet):
- Transfer B register to next A register.
 - Hold register 1A until 175°. (16)
 - Transfer A register to B register.
 - Energize interposer magnet. (2A)
 - Energize escape magnet. (12B)
 - Energize escape interlock relays. (9, 10). (10A)
 - Energize punch clutch. (10A)

Figure 4-21. Punch Out (46078), Wire Contact Relay Machines

3. Cycles 3, 4, 5, 6, and 7:
These cycles are similar to cycle 2.
4. Cycle 8 (punch an 8 in column 17):
Drop read out relay (42). (16B)
Open circuit to keyboard restore magnets. (42-5, 10B)
Punch out last digit.
Latch up punch clutch at 345°.

Left-Zero Credit Field

- An 11-punch in the units position indicates a credit field.

To indicate a credit field, the operator keys in the information just as in a debit field. To start the read out, punch out operation, the operator presses the dash (—) key instead of the left-zero key. Pressing the dash key causes a credit (11-punch) in the units column to be punched above the units digit.

Credit Read In

- The program card coding indicates a left-zero field.
- The operator keys in the correct digits.
- The information is stored.

Description

The program card is multipunched with a 7, 8, and 9 (program 2) in the high-order position indicating a 3-column field; for example, column 40 (see Figure 4-13). The rest of the field is punched with 4's defining the field. The operator keys in the correct number of digits, then presses the dash key to start the punch out, including an 11-punch over the digit in the units position. *In our example*, we key in one digit (5), and press the dash key to start punching.

Read In Cycle

Cycle 1: The machine is stopped at a left-zero field and the program 2 relay is up. The 7, 8, and 9 star-wheels energize the field size 1, 2, and 3 relays, and the field 1 and 2 relays.

The operator presses the correct key, which closes a latch contact, and energizes the correct 3A register relays through the encoding network and the field size relay points. The punch clutch is energized through the encoding network. At 45° of the punch clutch cycle, the keyboard is restored. The 3B register relays are energized at 86°, and the information transfers from register 3A to 3B (capacitor A registers transfer to B registers at 180°). Information in the B registers

is held until 65° of the next cycle by P2. *In this example*, a 5 is stored in register 3B.

Circuit Objectives

1. Cycle 1 (store a 5):
Close numeric-5 latch contact. (1A)
Enter numeric information into register 3A and energize the punch clutch.
Restore the keyboard. (10B)
Transfer register 3A to 3B.
Retain information in register 3B.

Credit Read Out, Punch Out

- The operator presses the dash key for a credit field.
- The information is read out and punched.
- The units column is multipunched. (Credit X over units position.)

Description

The operator presses the dash key, which energizes the relay necessary to start the read out and punch out, and also the relay to remember that this is a credit field. Each cycle reads out the digit to be punched and sets up the digit for the next cycle. When the end of the field is recognized, an extra cycle is taken to punch the 11-punch; this cycle is a multipunch cycle to prevent escapement from the units position of the field.

Read Out, Punch Out Cycles

Cycle 1: Refer to Figure 4-22 or 4-23 for timing within cycles. The operator presses the dash key, which closes the dash latch contact, and energizes the credit relay. As soon as the credit relay is up, the read out relay is energized through credit relay N/O points. The interposer magnet is energized (through field 2 N/O points and the 1A register decode tree), the keyboard is restored, an escapement to column 40 occurs, and a punch cycle is taken.

The keyboard restore magnets are energized and are held energized for the rest of the punch out cycles by P6 and the interposer bail contacts.

At 5° (P3), register 3B is transferred to register 2A. At P5 time (86°), the 2A register is transferred to the 2B register (capacitor A registers transfer to B registers at 180°). The interposer magnet is re-energized (through N/O points of the read out relay and the decode tree of the register 1A relay points). The escape magnet is energized at 180° by P1 and the interposer bail contacts. The escape armature contact makes, which energizes the escape interlock relays, and allows the punch clutch to be energized for the next cycle. *In this example*, the 0 interposer magnet

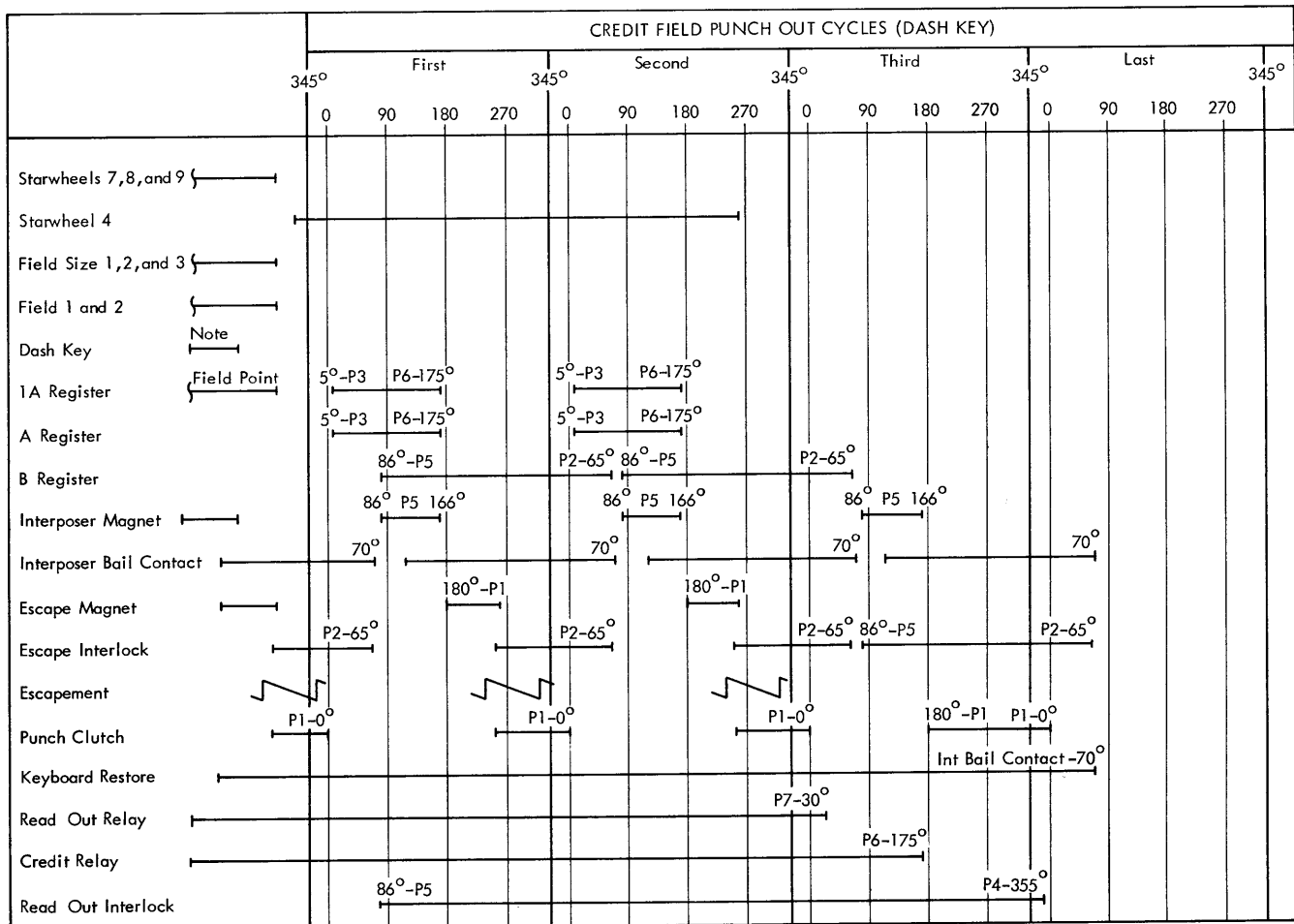

NOTE: The dash key picks the credit relay, the read out relay, and the first interposer magnet to start the punch out operation.

Figure 4-22. Punch Out Timing (3-Column Credit Field) Reed Relay A Registers, Wire Contact Relay Machines

is energized, an escapement to column 40 of the detail card occurs, a 0 is punched in column 40, the 0 interposer is re-energized, and there is an escapement to column 41.

Cycle 2: During this cycle, the digit that was set up on the previous cycle is punched. *In this example*, a 0 is punched in column 41, the digit 5 is transferred from 2B to 1A, the 5 interposer magnet is energized, and an escapement to column 42 of the detail card occurs.

Cycle 3: The last digit has been transferred from storage and is punched on this cycle. At 30°, the read out relay is dropped. (The credit relay is held by P6.) When P5 makes at 86°, the escape interlock relays are picked through read out relay N/C points and credit relay N/O points, and a punch cycle is taken. At P5 time, the 11 interposer is energized through read out relay N/C points and credit relay N/O points.

(The escape interlock relays prevent picking the escape magnet when the 11 interposer magnet is energized.) At 175°, the credit relay is dropped. *In this example*, a 5 is punched in column 42, the 11 interposer magnet is energized, and *no escapement occurs*.

Cycle 4: The credit 11 is punched during this cycle. At 65° (P2), the escape interlock relays are dropped. The interposer bail contacts open the circuit to the keyboard restore magnets. The punch clutch latches at 345°. *In this example*, an 11 is punched above the 5 in column 42.

Circuit Objectives

1. Cycle 1 (energize 0 interposer magnet for punching this cycle; re-energize for next cycle):

Close dash latch contact. (11 key, 1A)

Energize credit relay (41) and read out relay (42). (16B)

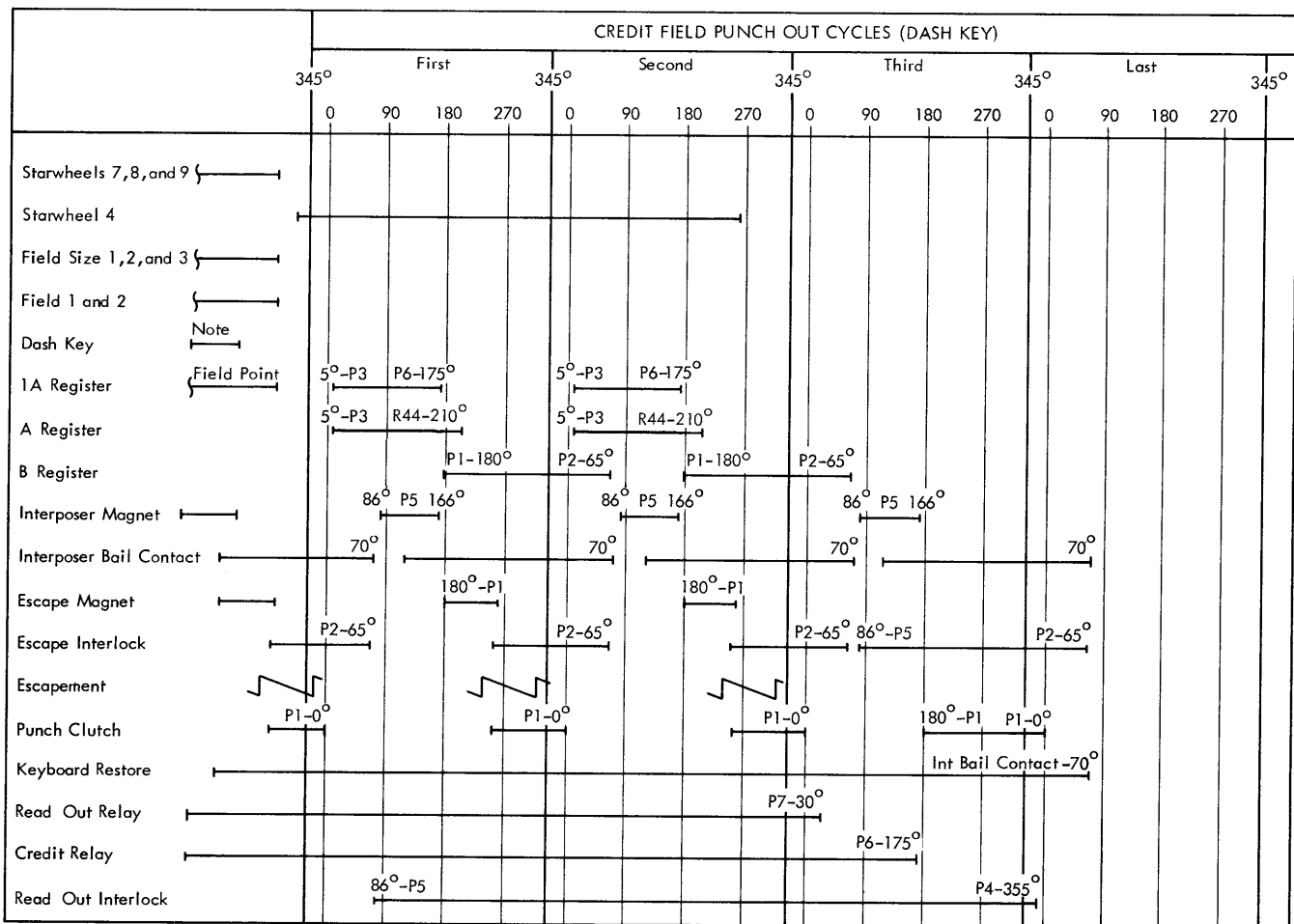

NOTE: The dash key picks the credit relay, the read out relay, and the first interposer magnet to start the punch out operation.

Figure 4-23. Punch Out Timing (3-Column Credit Field) Capacitor A Registers, Wire Contact Relay Machines

- Energize 0 interposer magnet.
- Restore keyboard magnets.
- Escape to column 40.
- Transfer information from register 3B to 2A.
- Transfer register 2A to 2B.
- Re-energize the 0 interposer magnet. (2A)
- Energize escape magnet. (12B)
- Energize escape interlock relays (9, 10). (10A)
- Energize punch clutch. (10A)
- 2. Cycle 2 (punch a 0, energize the 5 interposer magnet):
 - Transfer B registers to next A registers.
 - Hold register 1A information until 175°.
 - Transfer A registers to B registers.
 - Hold B registers until next cycle.
 - Energize 5 interposer magnet.

- Energize escape magnet.
- Energize escape interlock relays (9, 10). (10A)
- Energize punch clutch.
- Break starwheel 4 contact.
- 3. Cycle 3 (punch a 5, energize 11 interposer magnet):
 - Drop read out relay (42). (16B)
 - Energize 11 interposer magnet.
 - Energize escape interlock relays (9, 10). (10A)
 - Prevent energizing the escape magnet.
 - Energize punch clutch.
- 4. Cycle 4 (punch an 11 above the 5):
 - Drop escape interlock relays.
 - Open circuit to keyboard restore magnets.
 - Latch punch clutch.

Left-Zero Logic Controls

Figure 4-24 shows the basic left-zero operations and their controls. The read in operations are shown with solid lines. The diagram can be used for both troubleshooting and a quick reference to general operation.

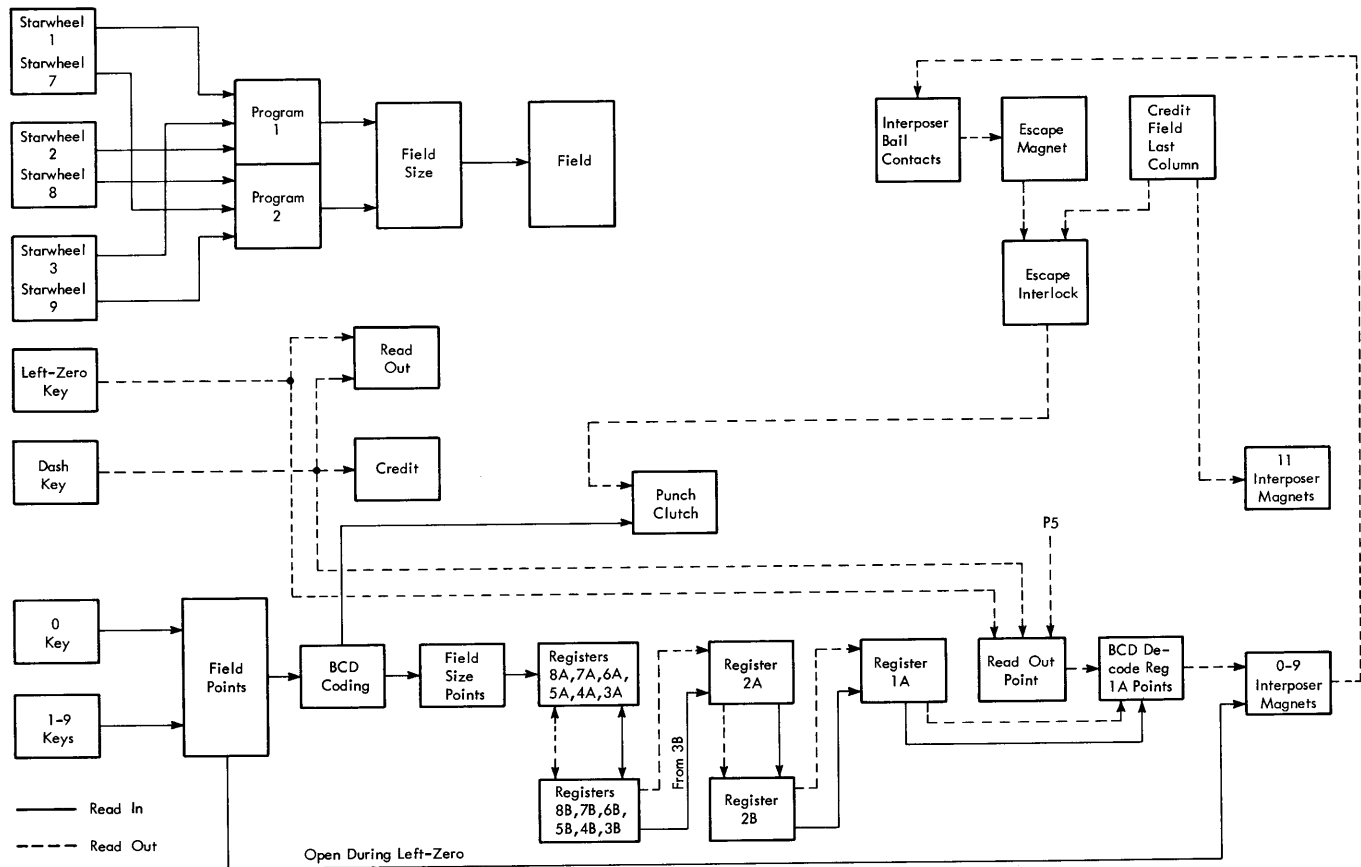

Figure 4-24. Left-Zero Logic Controls and Flow, Wire Contact Relay Machines

Chapter 5. Power Supplies and Control

- **The regulated ($\pm 10\%$) 48 volt at 1.65amp output supplies machine operating voltages.**

See the machine wiring diagram for correct connections of the ac line. The ac main line voltage can be 115v, 208v, or 230v, single phase, 60-cycle. Only one leg of the 115v input is fused. If a 208v or 230v input is used, both legs are fused. The ac input voltage can vary 10% and maintain correct machine operation.

The power supply circuit includes the motor switch and the test jack. The motor switch is a hand-operated toggle switch that turns the motor off and allows other areas of the machine to remain energized. It is useful when hand cycling of the machine is desired. Some adjustments are made with the motor stopped. The motor switch is located at the rear of the machine on the frame that mounts the reed relay gates.

The test jack is located on the power supply chassis and, when the main line switch is on, is the +48 volt source for the test probe.

NOTE: A limited number of early production machines were shipped with unregulated 3amp power supplies. The power supply page of each machine wiring diagram will indicate which power supply is installed in that machine.

Card Punch Voltages

- **The first objective is to supply the voltages necessary to operate the card punch.**
- **The power supply provides +48 volts dc, at 1.65amps, and 0 volts to operate the card punch.**
- **All voltages are available as soon as the main line switch is turned on.**
- **60 cycle operation only is described.**

As soon as the main line switch is turned on, 115vac enters the primary winding of the ferro-transformer. This ac line voltage is taken through the primary winding of the transformer and the main line switch. From here it goes through rectifiers CR1 and CR2. The rectifiers change alternating current to direct current. C1 acts as a resonant capacitor for the transformer. C2 is connected across the +48vdc at 1.65amps output and shorted by a bleeder resistor (R1). The high resistance of the parallel bleeder holds the capacitor charged to a point near peak value of the applied voltage at no load. Across the plus and minus terminals of the capac-

itors then, is developed the +48vdc at 1.65amps, and the zero volt potential. The +48v is fed through a 2amp long-time lag fuse (F3) to position 5 on terminal block 2 (TB2-5). TB2-4 is the reference point for zero voltage from the power supply.

The +48v to the punch circuits is from TB2-5, to CF4, common, to PCC2 operating strap, and from there to PCC1 operating strap.

Zero volts is supplied to the punch circuits from TB2-4 to P1 operating strap. The zero volt side of the card feed magnet is used as a source while troubleshooting.

You can now establish zero volt and +48 volt reference points on the wiring diagram. TB2-4 is the zero volt reference point in the power supply. Plus 48 volts will always be on the operating point of PCC1 and PCC2; 0vdc will always be on the operating strap of punch cam 1 (P1).

Figure 5-1 locates the components of the power supply. See "Chapter 7" for wiring diagram details.

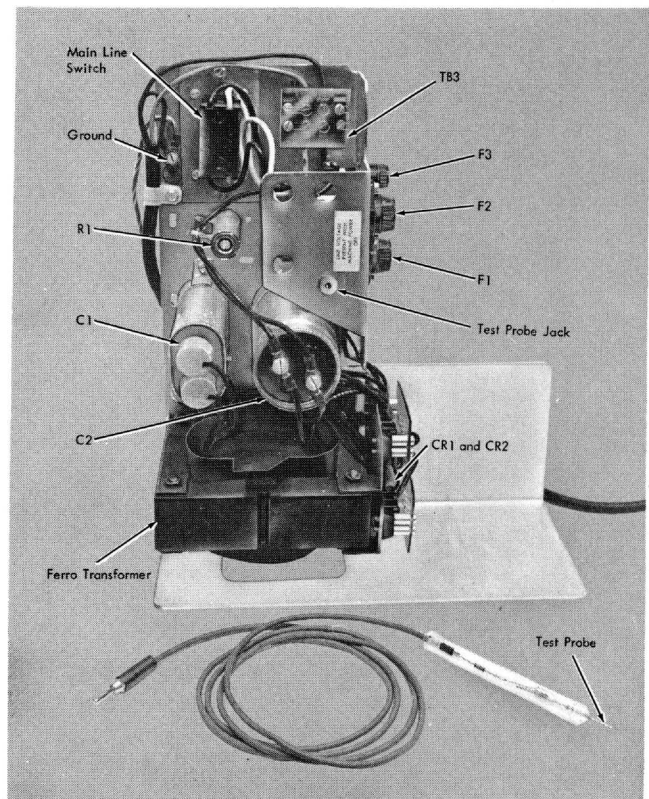

Figure 5-1. Power Supply

Power On

- **The main line switch is located on the lower right front of the machine.**
- **No warm-up period is required for machine operation.**

The motor control circuit consists of the main line switch, start relay, and motor. Closing the main line switch causes current to flow through the start relay coil and the run winding of the motor. This causes the start relay to operate or "pick up." When the start relay operates or "picks up," the motor starts because the normally open point of the relay completes the

circuit to the start winding of the motor. The start relay is a high and low current relay. On a 115vac line, the relay picks up when the current reaches 5.1 amps and drops out when it reaches 4.35 amps. The start relay contacts cut in the start winding of the motor in place of an internal starting switch inside the motor.

If the long-time lag fuse were blown, when the main line switch was turned on, the motor would not start. The machine is plugged into a 115vac outlet. With the main line switch on and the long-time lag fuse blown, a voltmeter placed across the fused terminals reads 115vac. With a good fuse, the meter would read zero volts.

Chapter 6. Console and Maintenance Features

Keys, Switches, and Indicators

Figure 6-1 shows the keys and switches associated with the numeric keyboard; Figure 6-2 shows the keys and switches associated with combination keyboards.

MAIN LINE SWITCH

Starts the motor and makes all machine functions immediately available.

Located on the lower right front of the machine.

STACKER SWITCH

Operated by the stacker card weight when about 500 cards are stacked.

When operated, prevents the card feed clutch being energized, except by the register key.

Located in the stacker.

BACKSPACE KEY

Backspaces the program card and cards at the punch and read station up to column 1.

Releases the keyboard when it becomes locked.

Located below the master station.

COLUMN INDICATOR

Indicates the next column to be encountered as cards pass the punch and read stations.

Located above the master station at the base of the program drum holder.

Toggle Switches on Switch Panel

ON/AUTO SKIP DUP

ON position makes program punching for automatic skipping and automatic duplicating effective.

AUTO SKIP DUP (off) position nullifies the 11-5 (start automatic skip), and 0-6 (start automatic duplication) codes in the program card.

Figure 6-2 shows the location on switch panel.

INSERT/STACK MC INSERT

A feature available on all models.

INSERT position allows the operator to insert a master card manually at the read station.

STACK MC INSERT position allows the operator to insert a master card manually in the stacker.

The functions are initiated by pressing the MC key (after the last detail card is registered, and before column 80 of the last detail card is punched or skipped).

ONE/TWO PROG SEL

ONE position: program 1 will be set for column 1 of the detail card during the CF cycle.

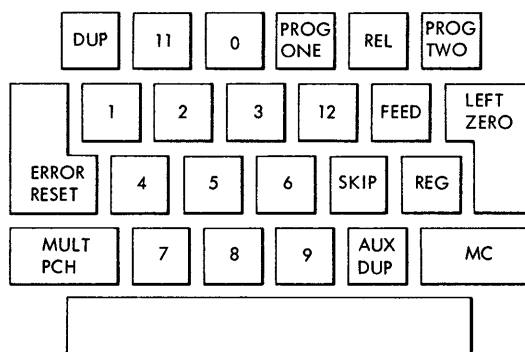
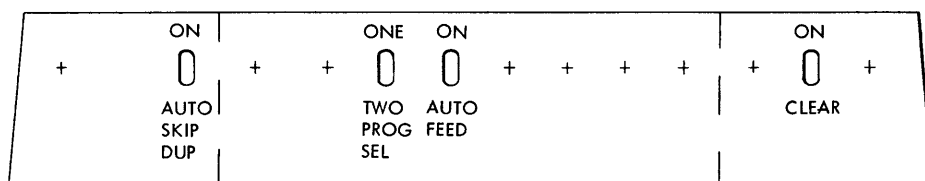

Figure 6-1. Numeric Keyboard and Switch Panel (Model B11)

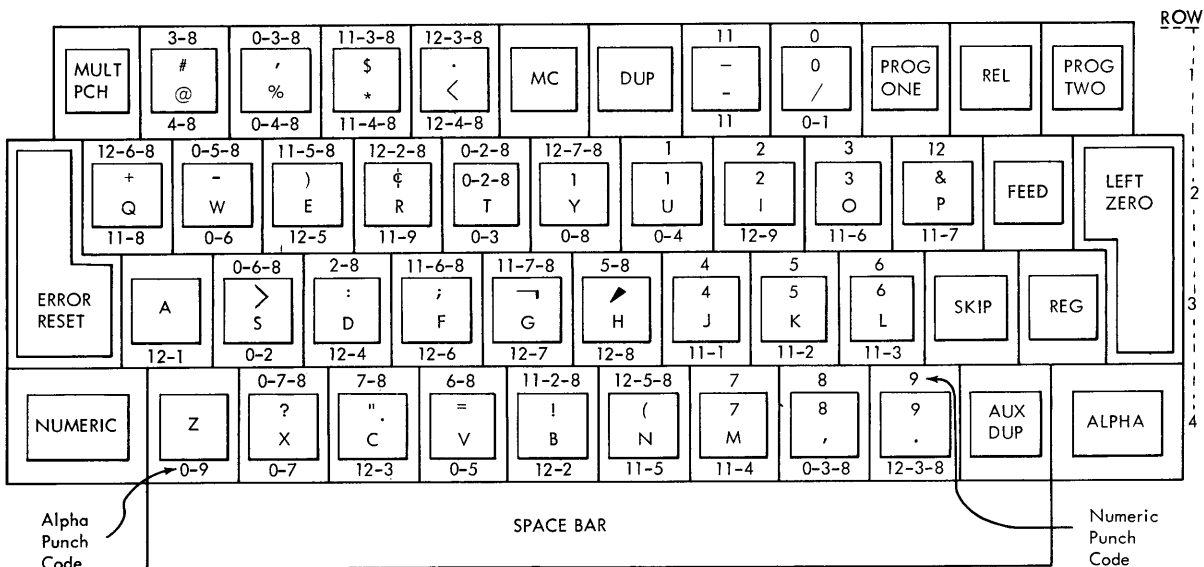
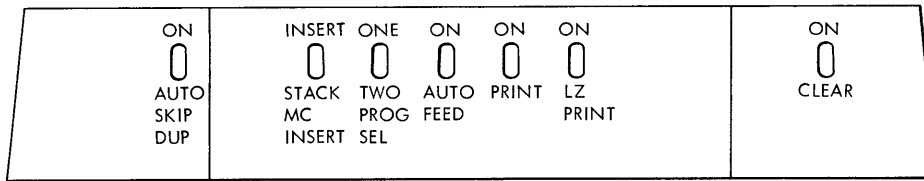

Figure 6-2. Combination Keyboard and Switch Panel (Model B22)

TWO position: program 2 will be set for column 1 of the detail card following the CF cycle.

ON/AUTO FEED

ON position: a new card is fed automatically whenever column 80 of the card passes the punch station; the card at the read station is stacked; the card at the master station is registered at the read station; the card at the detail station is registered at the punch station.

AUTO FEED (off) position: nullifies the automatic feeding functions.

ON/PRINT

A feature available on all models.

ON position: machine prints the character along the top edge of the card as each column is punched, and allows suppressing of zeros under control of the left-zero print switch.

PRINT (off) position: unconditionally suppresses all printing.

ON/LZ PRINT

Available on all models with printing feature.

ON position: all zeros to the left of the first significant digit print.

LZ PRINT (off) position: zeros to the left of the first significant digit of a field will not print, but the units position will print.

ON/CLEAR

Spring-loaded momentary contact switch.

CLEAR position: clears all cards from the feed bed, without feeding additional cards from the hopper.

One operation of the switch initiates the multiple cycles necessary to complete the clear operation.

Functional Keyboard Keys

NUMERIC

Shifts the combination keyboard into numeric position as long as the shift key is held down.

Normally used to punch numbers in an otherwise alphabetic field.

ALPHA

Shifts the combination keyboard into alphabetic position as long as the shift key is held down.

Normally used to punch letters in an otherwise numeric field.

DUP

With program control, duplicates the field for which it is pressed at 20 columns per second.

Without program control, duplicates at the rate of 10 columns per second as long as the key is pressed.

REL

Restores the keyboard.

Causes cards at the punch and read stations to be advanced completely past those stations.

Fields programmed for automatic duplication beyond the point of release are punched in the card as it advances.

FEED

Causes a card-feed cycle:

1. Feeds a card from the hopper.
2. Registers the card in the master station at the read station, and registers the card in the detail station at the punch station.
3. Stacks the card in the eject station.

SKIP

Causes skipping of the field for which it is pressed.

Normally used for skipping the right-hand portion of an alphabetic field.

REG

Registers cards at the punch and read stations.

Stacks the card in the eject station.

AUX DUP

Supplied only if the machine is equipped with the auxiliary duplication feature.

Causes the entire field to be duplicated from a master card on the auxiliary drum.

MULT PCH

Prevents normal spacing so that more than one digit can be punched in a column.

The keyboard is in numeric shift.

PROG 1

Shifts the machine to program 1 mode (upper half of program card).

Initiates a feed cycle when the automatic feed switch is off and a card has been processed through column 80.

PROG 2

Shifts the machine to program 2 mode and otherwise is the same operation as PROG 1.

ERROR RESET

Restores the keyboard.

On left-zero-insertion machines (Model B), when in a left-zero field, an error is erased by resetting storage.

SPACE BAR

Causes one-column space in a manual field.

Character Keys

- **The character keys are used manually to punch and print a card in the punch station.**

Numeric Keyboard consists of 12 single-purpose character keys that punch the digits 0-9, and two special characters (12- and 11-punches). The keyboard is so interlocked that no two keys can be operated at the same time. Multiple digits can be punched manually in one column by holding the multiple punch key down, while the keys are pressed one at a time.

Combination Keyboard consists of 34 character keys, all but two ("A" and "Z") of which are dual-purpose keys: upper and lower shift characters. Upper shift characters, shown on the key as the top character, can be punched in numeric shift. Lower shift characters, shown at the bottom of the key, can be punched in alpha shift.

Shifting is controlled automatically by the program unit, or manually by pressing ALPHA or NUMERIC. The period, dash, and comma are common to both shifts.

The "A" and "Z" keys function only in alpha shift, as they have no numeric representation. Pressing either the "A" or "Z" key in numeric shift will lock the machine. Operation can be resumed by releasing the card, backspacing, pressing the error reset key, or pressing the alphabetic shift key (which causes the letter to be punched).

The - (dash) key punches an 11 in either numeric or alphabetic shift. *It initiates no other action.*

The 12-punch is initiated by pressing the "&" key in numeric shift.

Interlock Circuits

STACKER SWITCH (N/C CONTACT)

Transferred by the stacker card weight at about 500 cards.

Opens the circuit to the card feed clutch.

Prevents feed cycles when transferred.

When this switch is transferred, only the register key can energize the card feed clutch.

DETAIL CARD LEVER (N/O CONTACT)

Left pressure rail in detail station.

Transferred when detail card is registered in punch station.

Picks card lever relays between 5° and 10° (second CF cycle).

Provides circuits for punching and all automatic functions except further card feeding.

READ CARD LEVER (N/O CONTACT)

Left pressure rail in master station.

Provides hold circuit for clear function.

KEYBOARD RESTORE MAGNETS (2)

Located in the keyboard.

Prevent manual punching while energized.

Energized by:

1. Backspace key.
2. Card feed cycle.
3. Dup key.
4. Skip operation.
5. Duplication operation.
6. Release operation.
7. Interposer bail contacts.
8. Error reset key.

MOTOR CONTROL SWITCH

Located on the right side of the circuit card mounting gate (as viewed from rear of machine).

Opens the circuit to the motor without interfering with the other machine circuits.

Operating Instructions

- Turn the main line switch on.
- Insert cards into the hopper and release the card pusher.
- Place a program card on the program drum and insert the program drum in the machine.
- Lower the starwheels.
- Turn the auto feed switch on, the auto skip/auto dup switch on, and the print switch on.
- Set the program select switch in the correct position.
- Press the release key.
- Press and hold the feed key until two cards are fed.
- Punch the card.
- The card punch is ready for all programmed operations.

Functional Operations

The IBM 29 Card Punch operations can be divided as shown in Figure 6-3. These operations are defined as:

Start and Run: Establishment of power (electrical and mechanical) necessary for machine operations. This includes the operation of the card feed, and the pick-and-hold of the card lever relay.

Interposer Selection: Engagement of an interposer or interposers with the punch bail in preparation for punching.

Escapement: Advancement of the program drum and of the escapement driven feed rolls.

Card Transport: Mechanical control of the movement of the card throughout the machine.

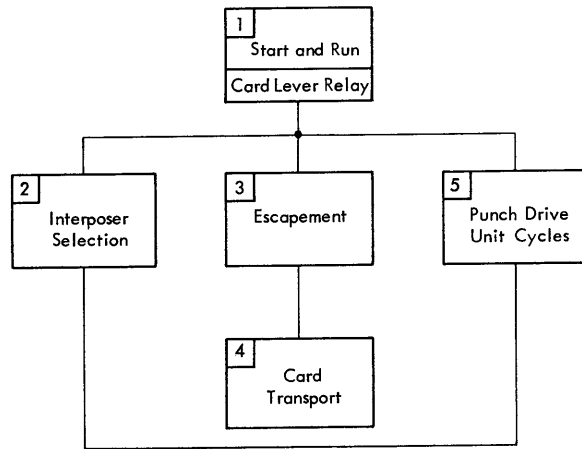

Figure 6-3. Operations

Punch Drive Cycle: Controlled rotation of the punch drive unit index shaft. According to the function, this is required to punch a hole in the card at the punch station, or to read a hole in the card at the pin sense station.

Sequence of Operations

It is essential that the customer engineer be aware of the correct sequence of operations as they are used in any machine function.

For example: the function is to punch a character from the keyboard. The sequence of operation is:

1. Start and run
2. Interposer selection
3. Escapement
4. Card transport
5. Punch drive cycle

By using the numbers only, we can show the sequence in this way.

- 1
- 2
- 3-4
- 5

Showing escapement and card transport (3-4) side by side indicates that while 3 causes 4, they happen at the same time. Using this notation, the sequence of these operations for all of the functions of the 29 are shown in Figure 6-4.

The functions shown in Figure 6-4 are the responses of the machine to the inputs given here:

Key Punch	Press any character.
Multiple Punch	Press the multiple punch key and any numeric key.
Key Skip	Press the skip key in numeric shift or alpha shift.
Manual Duplicate	Press the duplicate key for one or more columns with no programming.

Function	Key Punch	Mult Punch	Skip Key	Manual Dup	Blank Column Manual Dup	Auto Dup	Blank Column Auto Dup	Skip: Release, Auto, Drum	Release Auto Space
First Col	1 2 3-4 5	1 2 3-4 5	1 3 4-5	1 5-2 3-4 5	1 5 3-4 5	1 5-2 3-4 5	1 5 3-4 5	1 3-4	1 3-4 5
Second and Other Cols	Repeat for all Cols	2-5 Repeat for all Cycles	3-4 Repeat for Field Def	Repeat for all Cols	Repeat for all Cols	3-4 5-2 Repeat for Field Def	3-4 5-2 Repeat for Field Def	Repeat for all Cols	Repeat for all Cols
						3-4 5 Last Col			

Figure 6-4. Sequence of Operations

Blank Column Manual Duplicate

Press the duplicate key for one or more blank columns with no programming with the machine in alpha shift.

Auto Duplicate (Program 1)

Press the duplicate key or read a "0" in the program card in a column followed by "12's" in the program card.

Blank Column Auto Duplicate

As above but for blank columns with the machine in alpha shift.

Skip: Release Auto, Drum (Program 1)

Press the release key if the starwheels are up (or if down in a column programmed "12"). An "11" in a programmed card. A card-to-card skip occurs.

Release, Auto Space

Press the release key in a nonprogrammed field but with the starwheels down.

Manually Inserting and Registering Cards

A card can be placed manually in the detail station. Hand-feed the card under the card guide and move the card to the left, making sure that the right end of the card is under the card pusher arm. Press the register key to move the card into the punch station and align it in the correct position for punching column 1. *This card is registered in the punch station.* With the card registered in column 1 and no additional operations to be performed, the card can be stacked (after the following operations). Press the release key to move the card through the punch station. Press the register key to move the card into the read station. The card is then in the correct position to be read by the sensing mechanism at the read station. *This card is registered in the read station.* Press the release key to move the card into the eject station. Press the register key to move the card to the left and then up into the stacker.

Cards can also be manually inserted and registered in the master station. Upon manually inserting a card into the master station, pressing the register key regis-

ters the card in column 1 in the correct alignment so that the pin sensing mechanism can read the card. Pressing the release key moves the card into the eject station.

NOTE: Pressing the register key actuates the feed mechanism but does not feed a card from the hopper. This allows the operator to register a card in the punch or read station and prevent feeding a card from the hopper.

If the register key is pressed while a card is registered at the punch station, the register key will stay down. The release key, error reset key, or the backspace key must be pressed to restore (clear/unlock) the keyboard.

Numeric and Alphabetic Information

- This is controlled manually by the alpha and numeric keys.
- It is controlled automatically by the program card.
- The combination keyboard is in either numeric or alphabetic shift. Numeric shift is the upper character on the keyboard. Alphabetic shift is the lower character on the keyboard.
- The keyboard is in alphabetic shift when program control is off (and vice versa).

On the combination keyboard a group of keys is used to punch either numeric or alphabetic information.

There are no upper or lower case letters in the IBM hole code; just letters, digits, and special characters. The card punch is either in alphabetic or numeric shift. To punch letters, the card punch must be in alphabetic shift; to punch digits, the card punch must be in numeric shift; and to punch special characters, either alphabetic or numeric shift is used, depending on the special character that is to be punched.

The keyboard shift is controlled manually by pressing the numeric or alphabetic shift keys, or automatically by the program unit. If the program unit is not being used, program control is off. With program control off, the card punch is in *alphabetic* shift.

Example: When the card punch is in alphabetic shift, the combination 5K key is pressed and a K (11-2) punches in the card. A digit 5 will be punched if the numeric shift key and the 5K key are pressed at the same time.

Keys that punch in either alphabetic or numeric shift are *combination* keys. The "A" and "Z" keys are the only single-purpose keys on the combination keyboard.

The two most common special characters are the ampersand (&) and the dash or hyphen (-). The

ampersand is represented by a 12-punch in the card, and the dash (hyphen or minus) by an 11-punch. These are the only special characters that can be punched on the numeric keyboard. On the combination keyboard, the dash is punched by pressing the dash key in either alpha or numeric shift. The ampersand is punched by pressing the &P key (combination keyboard) while in numeric shift.

Pressing an improper key, while in numeric shift, will cause that key to stay down and the keyboard will lock up. An example would be pressing the "A" or "Z" key while in numeric shift. The keyboard can be restored by pressing the release key, backspace key, or error reset key.

Program Card Preparation

- **The program card controls all automatic punching operations.**

Correct punching in a given column of the program card controls all automatic punching operations in the corresponding column of the card that is being punched. The particular punching that is required depends on the functions to be controlled. Each digit row in the program card serves a specific purpose.

For program 1 mode operations, the operator punches a 12-hole in all columns of the program card, except the first column of every field to be punched, skipped, or duplicated. For program 2 mode operations, the operator punches a 4-hole in all columns, except the first column of every field to be punched, skipped, or duplicated.

When consecutive fields are to be skipped or duplicated, program them as a single field. In program 1 mode, the 12-contact is used for a hold circuit throughout a field that was set up by punching in the first column of the field. In program 2 mode, the 4-contact is used for a hold circuit throughout a field that was set up by punching in the first column of the field.

During the skipping operation in either program 1 or program 2 mode, the 12- or 4-punch in the program card permits skipping over all but the first column of that field at 12 milliseconds per column. The 12-position in program 1 mode and the 4-position in program 2 mode are referred to as *field definition*.

An 11-hole initiates an automatic skip in program 1 mode operation. A 5-hole initiates an automatic skip in program 2 mode operation. These punches in the first column of any field automatically start a skip over that field. The skip is continued by the 12- or 4-hole punched in the remaining columns of that field.

A 0-hole starts automatic duplication in program 1 mode. A 6-hole starts automatic duplication in pro-

gram 2 mode. These punches, depending on which position the program 1/program 2 switch is in, in the first column of any field start automatic duplication of the field. The 12-holes (program 1) or the 4-holes (program 2) continue (define) the rest of the field.

Punch 1's in program 1 mode, 7's in program 2 mode, in all columns of all alphabetic fields in the program card. Under program card control, the combination keyboard is normally in numeric shift. However, in an alphabetic field, the 1's in program 1 mode and the 7's in program 2 mode of the program card shift the multiple-purpose keys of the combination keyboard to punch the lower characters on the keys instead of the upper characters on the keys. During automatic duplication of alphabetic information, the 1-holes in program 1 mode, and the 7-holes in program 2 mode, also cause automatic spacing over blank columns.

During automatic duplicating in a numeric field, the machine stops if a blank column is sensed. It is then necessary to press ALPHA or to have 1's or 7's (depending on which position the program 1/program 2 switch is in) punched in the program card. Numeric information can be duplicated automatically whether it is programmed for the alphabetic or numeric keyboard. The 1's or 7's allow automatic spacing in a numeric field when blank columns are to be sensed.

Numeric Keyboard: When duplicating is performed, the 1-punch in program 1 mode, or the 7-punch in program 2 mode, in the program card serves a similar purpose. These punches in the program card permit automatic spacing over the blank column of an automatically duplicated field.

Clearing a Locked Keyboard: When the machine is duplicating without 1's in program 1 mode, or 7's in program 2 mode, in the program card, duplication into a blank column locks the machine. Clear this condition by one of three methods:

1. If the machine has a combination keyboard, press ALPHA to space over the blank column.
2. Lift the starwheels to space over the blank column.
3. Press the backspace key to drop out the duplicate relays.

Use the third method to unlock the keyboard when it is electrically locked.

Program Drum Installing: After a special code is punched into a data card, place the card on the cylinder called the *program drum*. The card is held on the program drum by a clamping strip that is manually operated by a clamping-strip handle (located inside the program drum at the 12-edge end of the program card).

Insert the drum on its shaft into the machine. It is held by a detent spring on the drum hub. A pin aligns the drum with the column indicator wheel.

Press the release key to advance the program drum to column 1.

Manual Numeric Field

- **Program 1:** A blank (space) in the first column of the field designates a manual numeric field, and 12's in all columns except the first, define the field.
- **Program 2:** A blank (space) in the first column of the field designates a manual numeric field, and 4's in all columns except the first, define the field.

Place the keyboard in numeric shift by turning the program control lever to the left and lowering the starwheels on the program card. When the starwheels are down, program control is on. Field definition punches do not shift the keyboard. A single-column manual numeric field is represented by a blank column in the program card not followed by 12's or 4's.

The 12's used in program 1, and the 4's used in program 2, are called field definition punches and are used to define the rest of the field. The field definition punches do not shift the keyboard, but they do allow the operator to complete a skip or duplication after the first few columns of the manual field are punched.

Manual Alphabetic Field

- **Program 1:** Punch 1's in all columns of the field, and 12's in all columns except the first, to define the field.
- **Program 2:** Punch 7's in all columns of the field, and 4's in all columns except the first, to define the field.

When the starwheels are lowered, the keyboard will be in numeric shift with a blank card in the program drum. In program 1 mode, 1-punches in the program card cause the keyboard to go into alphabetic shift. In program 2 mode, 7-punches in the program card cause the keyboard to go into alphabetic shift. In alpha shift, the dual purpose keys punch the alpha punch code of the lower graphic on that key. This can be done without having to press the alphabetic key. A single-column manual alphabetic field is represented by a 1 in the program card not followed by 12's and 1's, or 4's and 7's.

Manual Skip (Program Controlled)

- **Program 1:** The skip key initiates a skip and the 12-holes in the program card continue the skip to the end of the field.

- **Program 2:** The skip key initiates a skip and the 4-holes in the program card continue the skip to the end of the field.

If the program card is blank in either program 1 mode or program 2 mode, pressing the skip key results in the card punch taking a single space. If program control is off, pressing the skip key also results in the card punch taking a single space.

Automatic Skip

- **Program 1:** Punch an 11-hole to initiate an auto skip (automatic skip), and 12-holes in the remaining columns of that field.
- **Program 2:** Punch a 5-hole to initiate an automatic skip, and 4-holes in the remaining columns of that field.

The auto skip operation is made active by lowering the starwheels and turning on the auto skip/auto dup switch. A single column auto skip field is represented in program 1 by an 11-punch in a column of the program card, and in program 2 by a 5-punch in a column on the program card.

Automatic Duplication (Numeric Information)

- **Program 1:** Punch a 0 in the program card to initiate automatic duplication, and 12's in all columns except the first, to define the field.
- **Program 2:** Punch a 6 in the program card to initiate automatic duplication, and 4's in all columns except the first, to define the field.

When a field of information is transferred from a card at the master station to a card at the punch station, under control of the program drum, the operation is called *auto dup* (automatic duplication). If a blank column is sensed at the read station and the card punch is in numeric shift, the machine will lock up.

Automatic Duplication (Alphabetic Information)

- **Program 1:** Punch a 0 and a 1 in the first column of the field, and 12's and 1's in all columns except the first, to define the field.
- **Program 2:** Punch a 6 and a 7 in the first column of the field, and 4's and 7's in all columns except the first, to define the field.

Both alphabetic and numeric information can be automatically duplicated in alpha shift. If a blank column is sensed at the read station and the card punch is in the alphabetic shift, the blank column will duplicate as a blank.

Manual Duplication (Program Control On)

- **This is designated by the field definition punches (12's or 4's in the program card).**
- **Numeric or alphabetic information can be manually duplicated.**

Pressing the dup key with program control on, causes manual duplication to appear at different rates of speed. The rate of speed depends on the punches in the program card. If the dup key is pressed just once in a field containing 12's, these *field definition* punches continue any duplication started by the dup key, at the rate of 20 columns per second. If the dup key is pressed in a blank column in the program card, duplication occurs at the rate of 10 columns per second.

5373565

00.29.01.1

POWER SUPPLY 50 CYCLE
48V AT 1.65A POWER SUPPLY

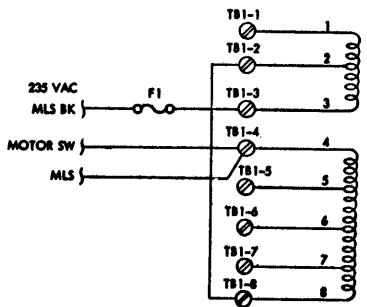
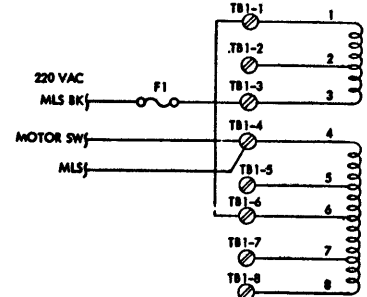
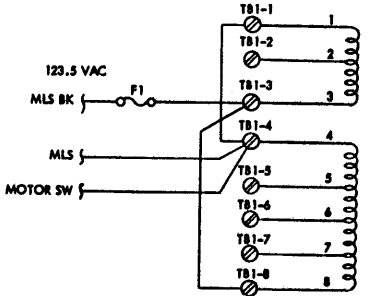
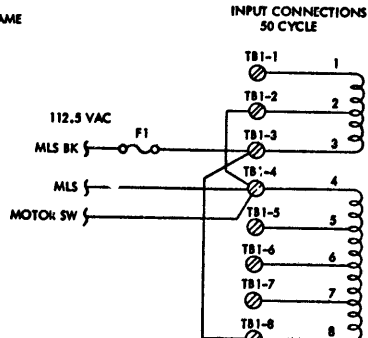
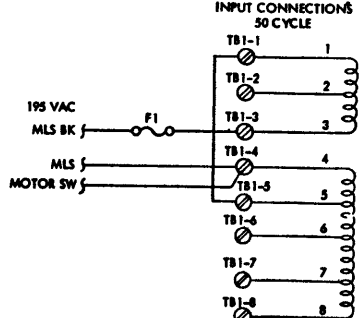
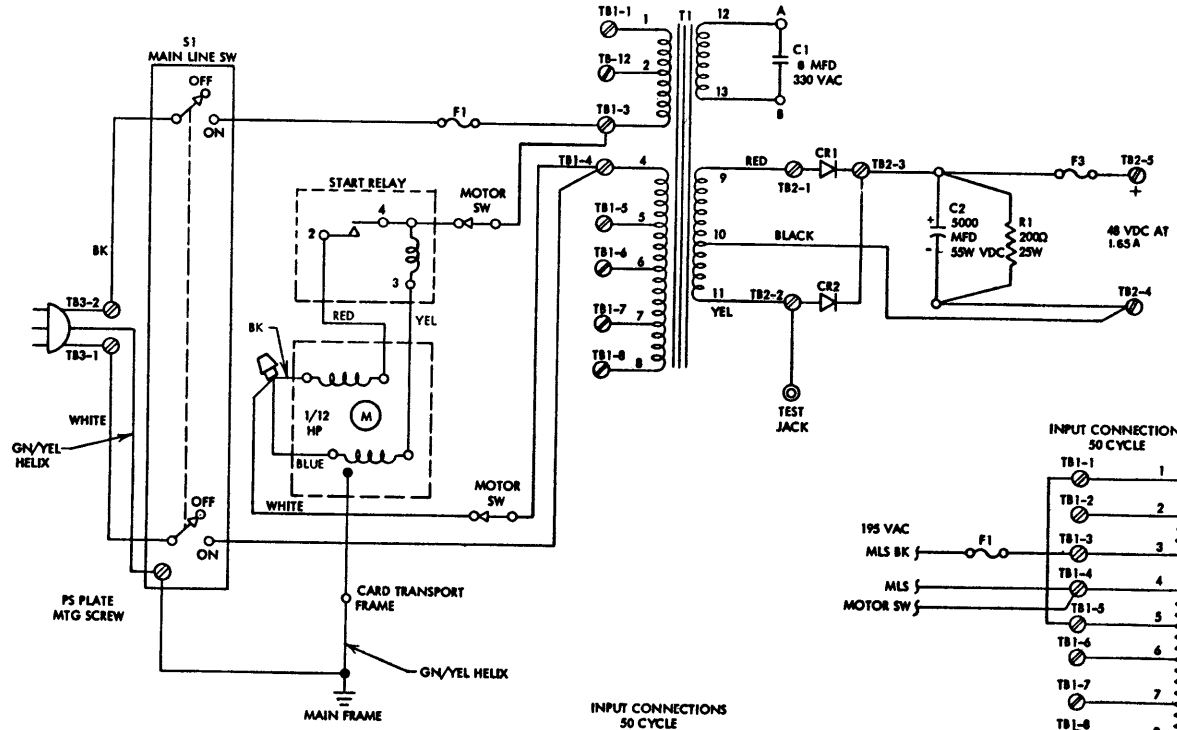

NAME	PART NUMBER
T1	5404086
C1	5247156
C2	208222
CR1 2A	5404082
CR2 2A	5404082
R1	221110
S1	5372190

LONG TIME LAG FUSE			
	AMPS	PART NO.	VOLTS AC
F1	4.0	107665	112.5
F1	4.0	107665	123.5
F1	2.0	92734	195
F1	2.0	92734	220
F1	2.0	92734	235

FUSE	AMPS	PART NO.	VOLTS DC
F3	2	3344	48

INTERNATIONAL BUSINESS MACHINES CORP.		DATE	CHANGE NO.	DATE	CHANGE NO.	NOTE	DEVELOPMENT NO.
NAME		7-6-65	205332			X PRINT TO ENG. OPER. NO. 895291	00.29.01.1
SYSTEMS DIAGRAM		11 MAR 66	205542				
DESIGN	WT	5-6-65	MODEL				
CHECK	LF	5-6-65	DRAW	141	4-30-65		
APPROV	RLJ	5-6-65	CHECK				

5373565

5373566

POWER SUPPLY 60 CYCLE-
48V AT 1.65A POWER SUPPLY

00.29.01.1

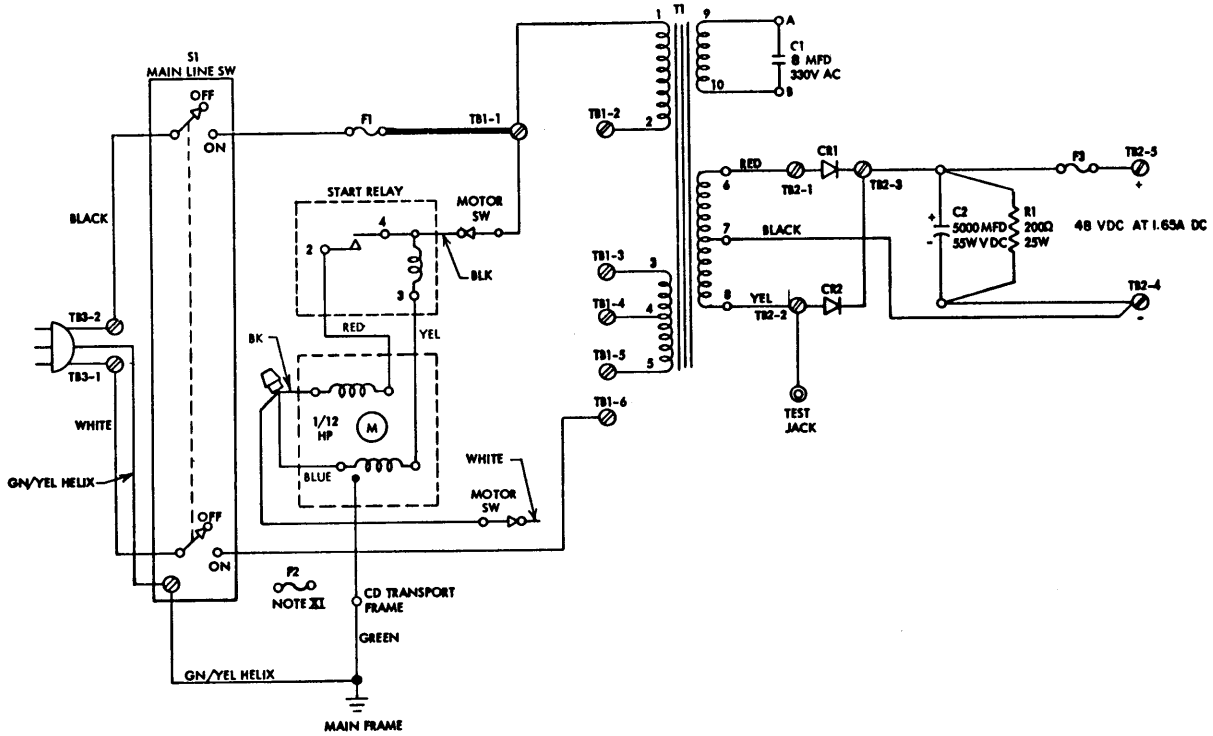

NAME	PART NO.
T1	5404081
C1	5247156
C2	208222
CR1 2A	5404082
CR2 2A	5404082
R1	221110
S1	5372190

LONG TIME LAG FUSE			
	AMPS	PART NO.	VOLTS AC
F1	4.0	107665	115
F1	2.0	92734	208
F1	2.0	92734	230
F2	2.0	92734	208
F2	2.0	92734	230

FUSE	AMPS	PART NO.	VOLTS DC
F3	2	3344	48

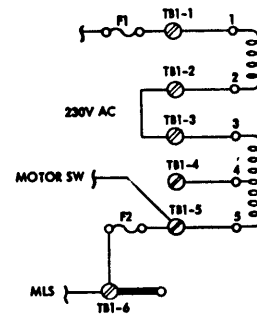
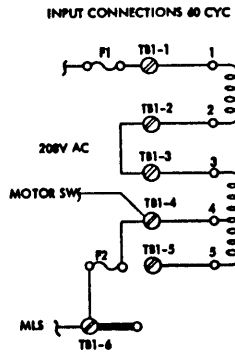
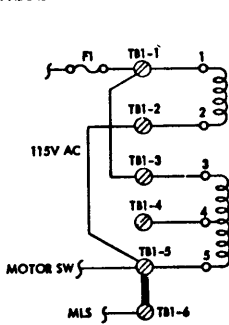

NOTES
XI FOR 115V OPERATION F2 WILL NOT BE USED

INTERNATIONAL BUSINESS MACHINES CORP.		DATE	CHANGE NO.	DATE	CHANGE NO.	NOTE	DEVELOPMENT NO.
NAME	SYSTEMS DIAGRAM	7-8-65	205332			NOTE X PRINT TO ENL. SPEC. NO. 895291	00.29.01.1
	00.29.01.1	11 MAR 66	205542				
DESIGN	WT 5-6-65 MODEL						
DETAIL							
CHECK	LF 5-6-65 DRAW ML 4-30-65						
APPRO	RLJ 5-8-65 CHECK						

5373566

5393433

LEFT ZERO

REED RELAY
NUMERIC KEYBOARD AND INTERPOSERS

2

01.29.02.1

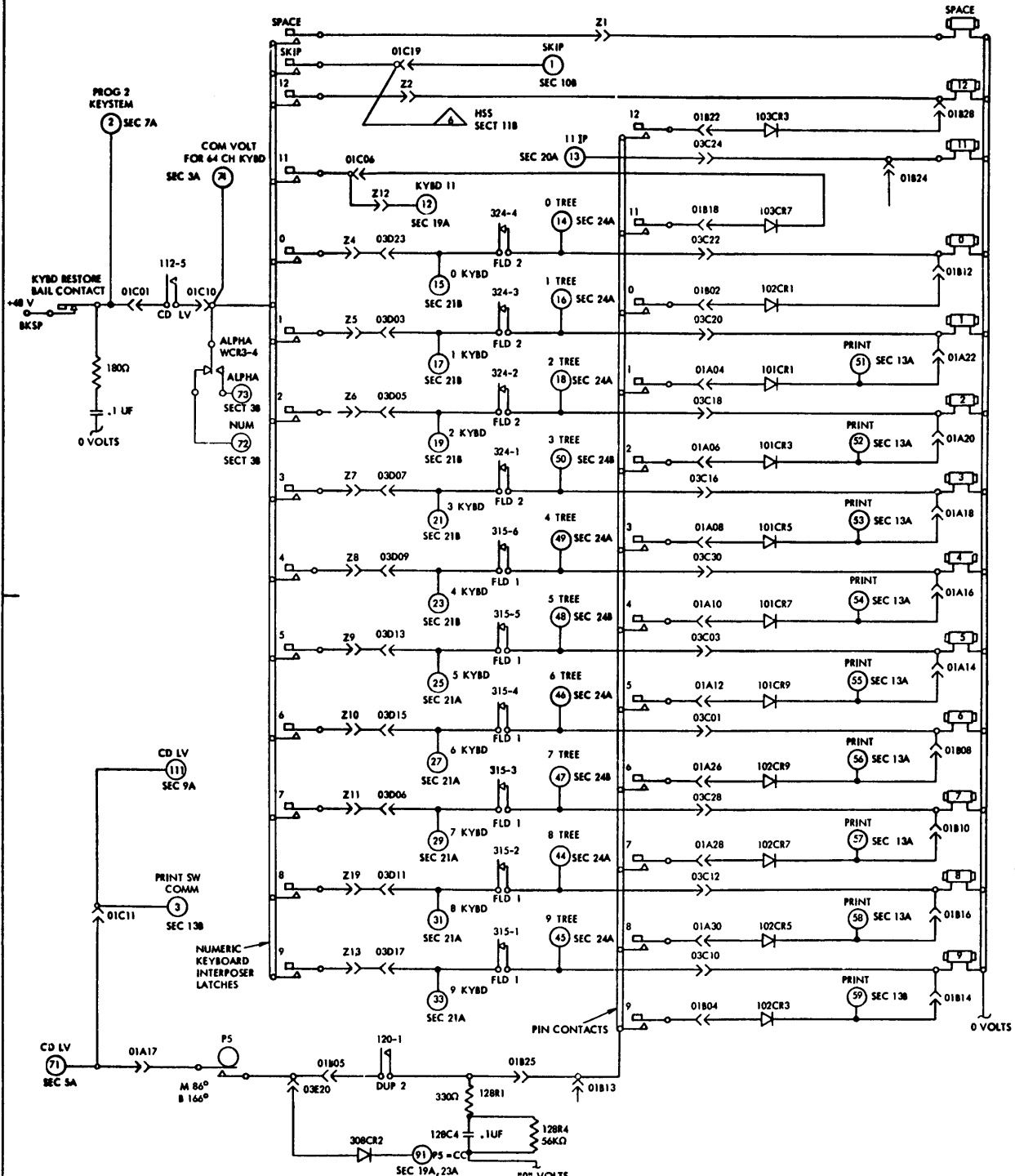

NOTES:
X1 POINT TO POINT WIRING FOR +48 AND "0" VOLT
NET SHOWN ON REE PAGE

INTERNATIONAL BUSINESS MACHINES CORP.		DATE	CHANGE NO.	DATE	CHANGE NO.	NOTE	DEVELOPMENT NO.
NAME	SYSTEMS DIAGRAM	5-14-65	205293-A			NOTE X1 PRINT TO ENG. SPEC. NO. 895291	5393433
	01.29.02.1	28OCT65	20542-C				
DESIGN	RF 3-7-65	MODEL					
DETAIL	WT 3-25-65						
CHECK	RAS 3-25-65	DRAW	GT 9-12-65				
APPROV	RLJ 3-25-65	CHECK	KWL 3-4-65				

01.29.02.1

537354

00.2903.1

REED RELAY
64 CHARACTER KYBD

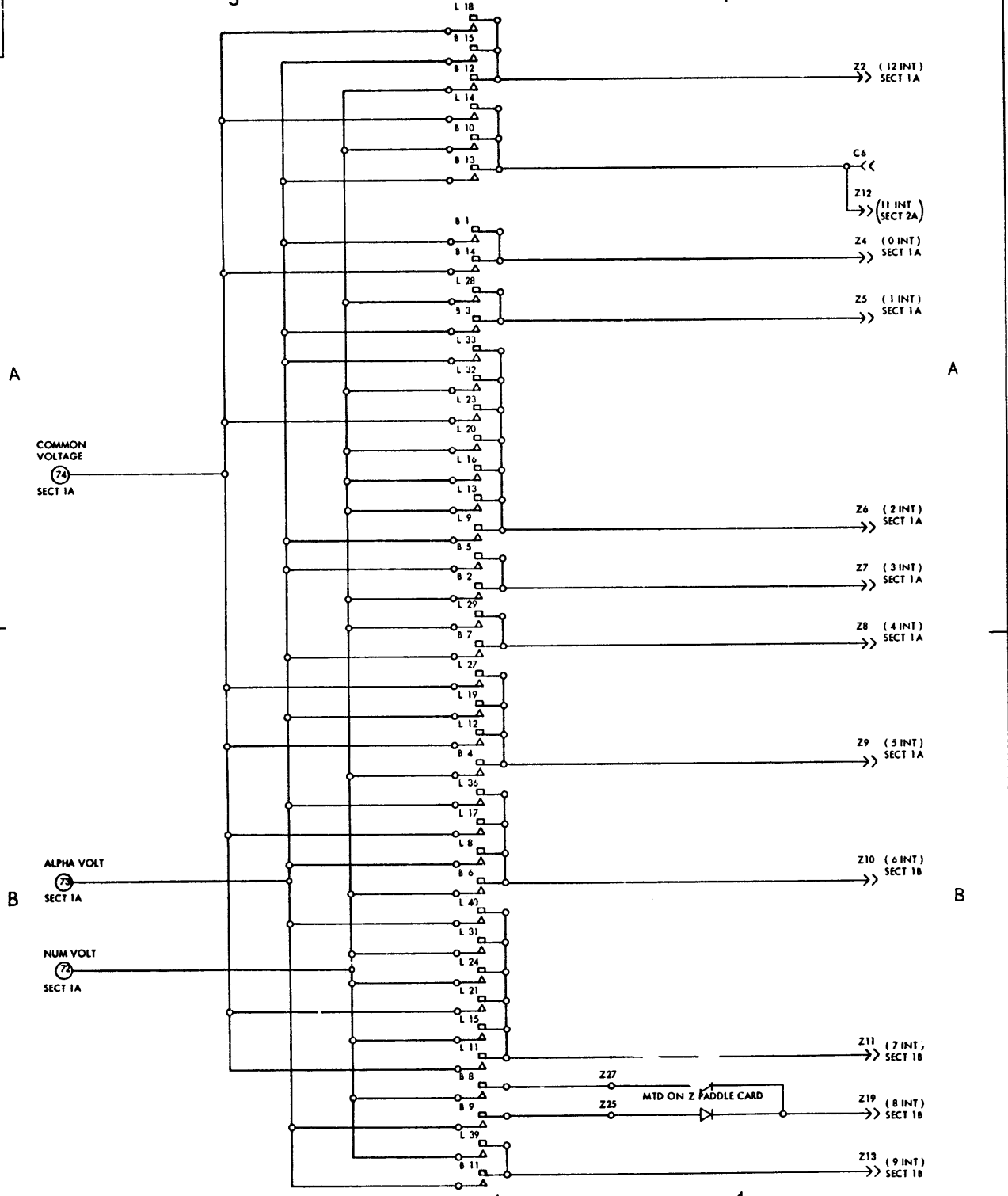

INTERNATIONAL BUSINESS MACHINES CORP.		DATE	CHARGE NO.	DATE	CHARGE NO.	NOTE	DEVELOPMENT NO.
NAME SYSTEMS DIAGRAM		12-30-64	205199			NOTE 1 PRINT TO ENG. SPEC. NO. 895291	00.2903.1
00.29.03.1		2-18-65	205260				
DESIGN	WF	2 OCT 64					
DETAIL	WF	2 OCT 64					
CHECK	LF	2 OCT 64					
APPRO	JKC	2 OCT 64					

5393434

REED RELAY MP, CD FEED, CLEAR, RELEASE

01.29.04.1

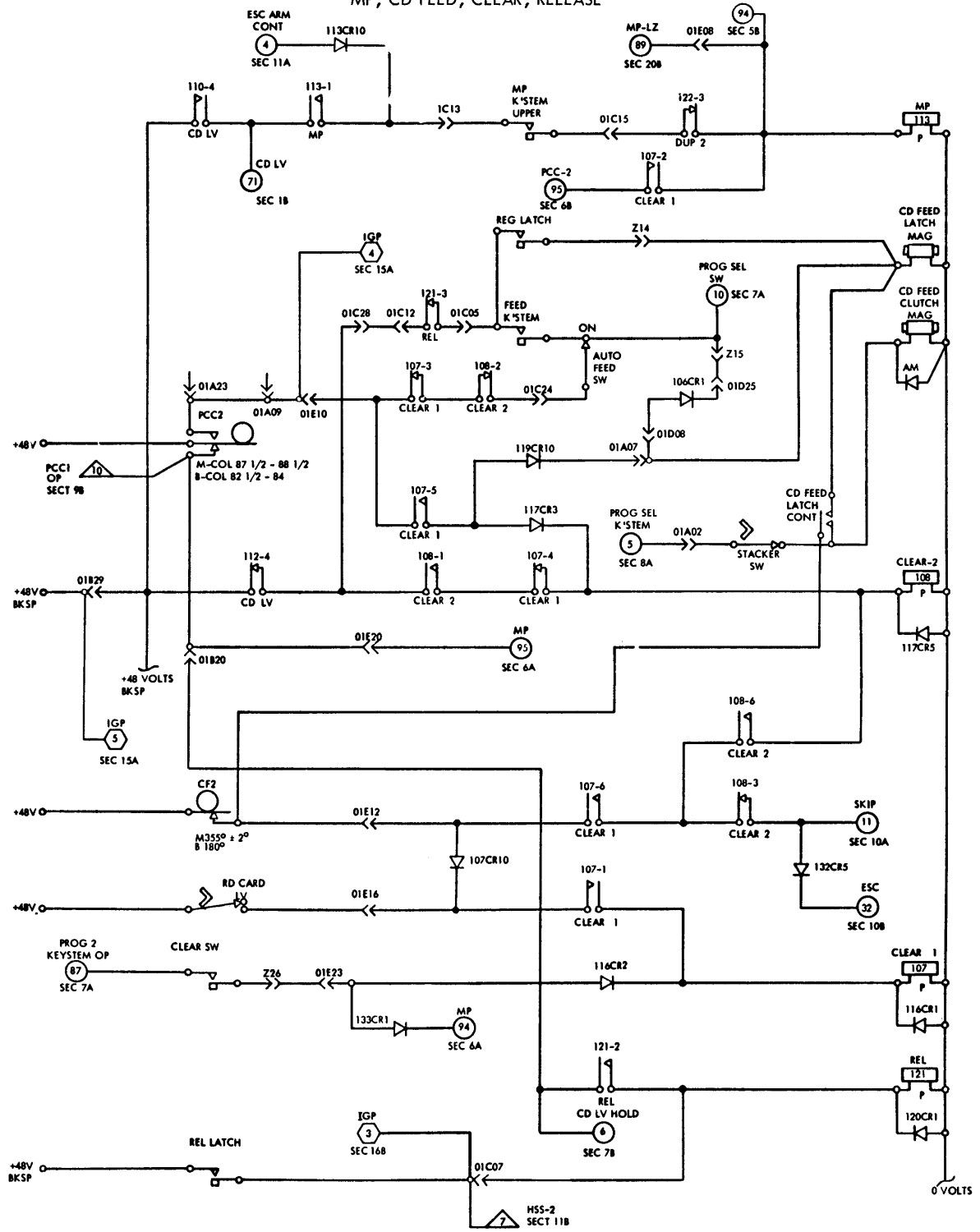

NOTES:
 XI POINT TO POINT WIRING FOR +48V AND "0" VOLT
 NETS SHOWN ON 01.29.18.0 REF PAGE

INTERNATIONAL BUSINESS MACHINES CORP.		DATE	CHANGE NO.	DATE	CHANGE NO.	NOTE	DEVELOPMENT NO.
NAME SYSTEMS DIAGRAM		5-14-65	205293-A			NOTE X PRINT TO ENB. SPEC. NO. 895291	5393434
01.29.04.1		28OCT65	205425C				
DESIGN	BF 3-25-65	MODEL					
DETAIL	WT 3-25-65						
CHECK	RAS 3-25-65	DRAW	GT 2-12-65				
APPRO	RL 3-25-65	CHECK	RWL 3-4-65				

01.29.04.1

5393435

7

REED RELAY
KEYBOARD RESTORE, PROG SEL, CD LV

8

01.29.05.1

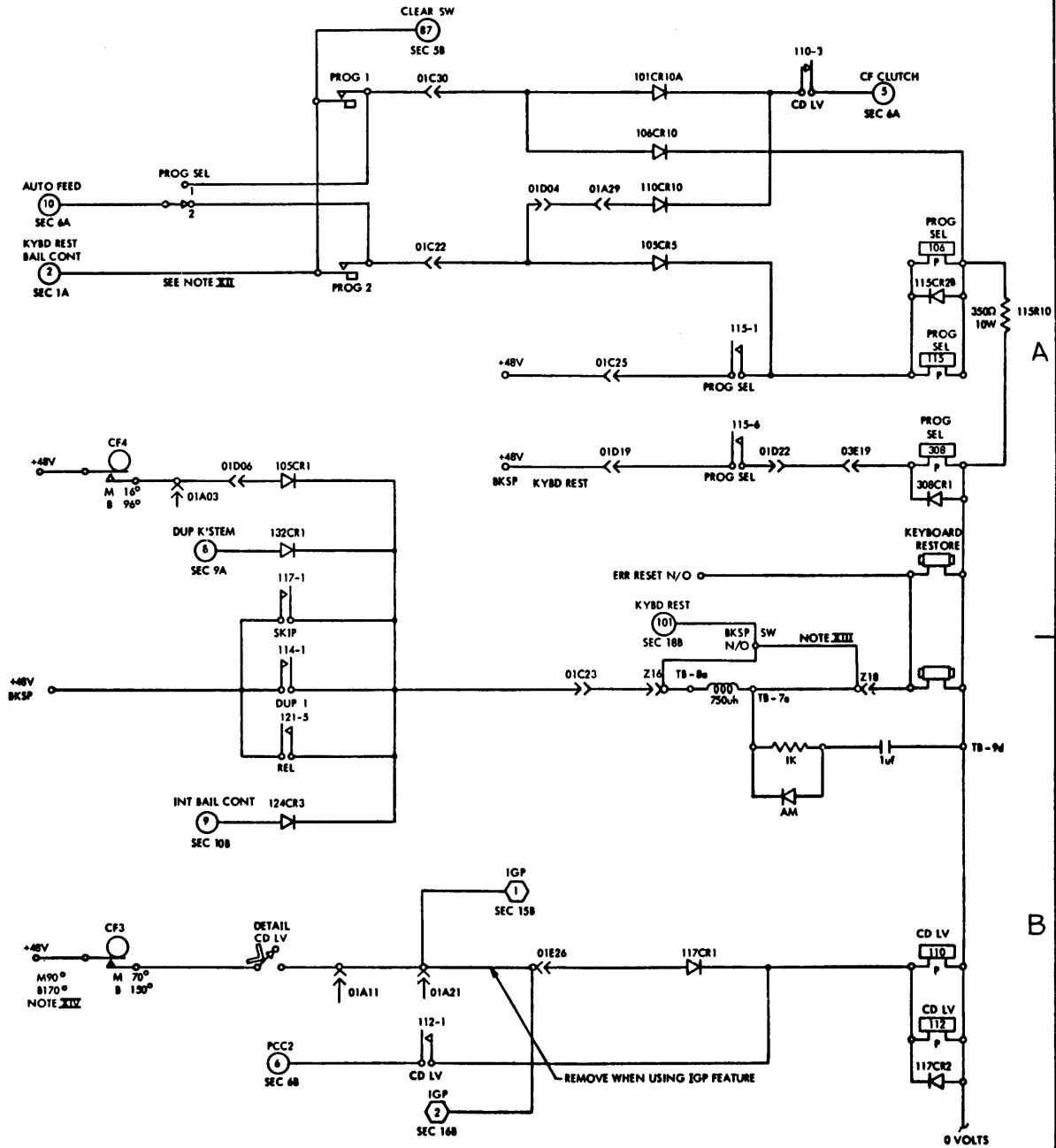

NOTES:

- XI POINT TO POINT WIRING FOR +48V AND "0" VOLT NETS SHOWN ON REF PAGE
- XII POINT TO POINT WIRING SHOWN ON REF PAGE
- XIII EARLY MODEL MACHINES HAVE BACKSPACE SW N/O WIRED TO Z18
- XIV CAM TIMINGS FOR HSS AND VLCD ONLY

INTERNATIONAL BUSINESS MACHINES CORP.		DATE	CHANGE NO.	DATE	CHANGE NO.	NOTE	DEVELOPMENT NO.
DATE	5-14-65	205293-A				NOTE 1 POINT TO ENL. OPAL. NO. 095291	5393435
REVISION	01.29.05.1	28OCT65	205423C				
DESIGN	BY 3-25-65	25MAY66	205639				
DRAWN	BY 3-25-65						
CHECKED	BY 3-25-65						
APPROVED	BY 3-25-65						

01.29.05.1

5393436

REED RELAY DUP, ESCAPE, SKIP, VLCD

01.29.06.1

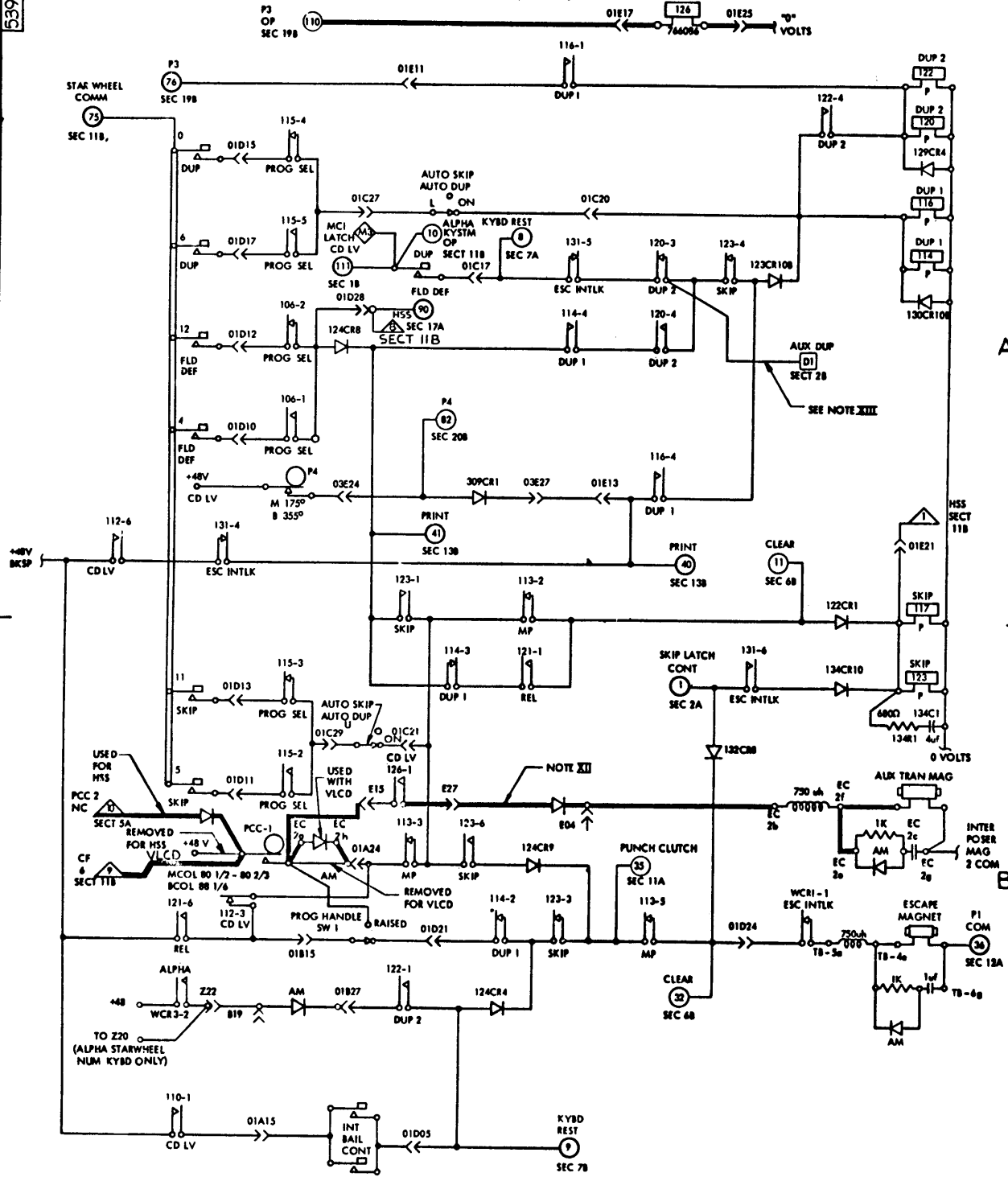

NOTES:
 XI POINT TO POINT WIRING FOR +48V AND "0" VOLT NETS SHOWN ON REF PAGE
 XII HEAVY LINES REPRESENT FEATURE INFORMATION
 XIII ON "D" LEVEL CARD AUX DUP HOLD CIRCUIT IS YELLOW WIRE

INTERNATIONAL BUSINESS MACHINES CORP.		DATE	CHANGE NO.	DATE	CHANGE NO.	NOTE	DEVELOPMENT NO.
NAME SYSTEMS DIAGRAM		5-14-65	205293-A			2 POINT TO ENCL. ENCL. NO. 095291	5393436
01.29.06.1		28OCT65	205425C				
DESIGN BF	3-25-65	MODEL	IMAR66	205542			
DETAIL WT	3-25-65						
CHECK RAS	3-25-65	GT	B-12-65				
APPROV RLJ	3-25-65	CHECK	KVL	3-4-65			

01.29.06.1

5393437

REED RELAY
PUNCH CLUTCH, ESC INTLK, ALPHA

01.29.07.1

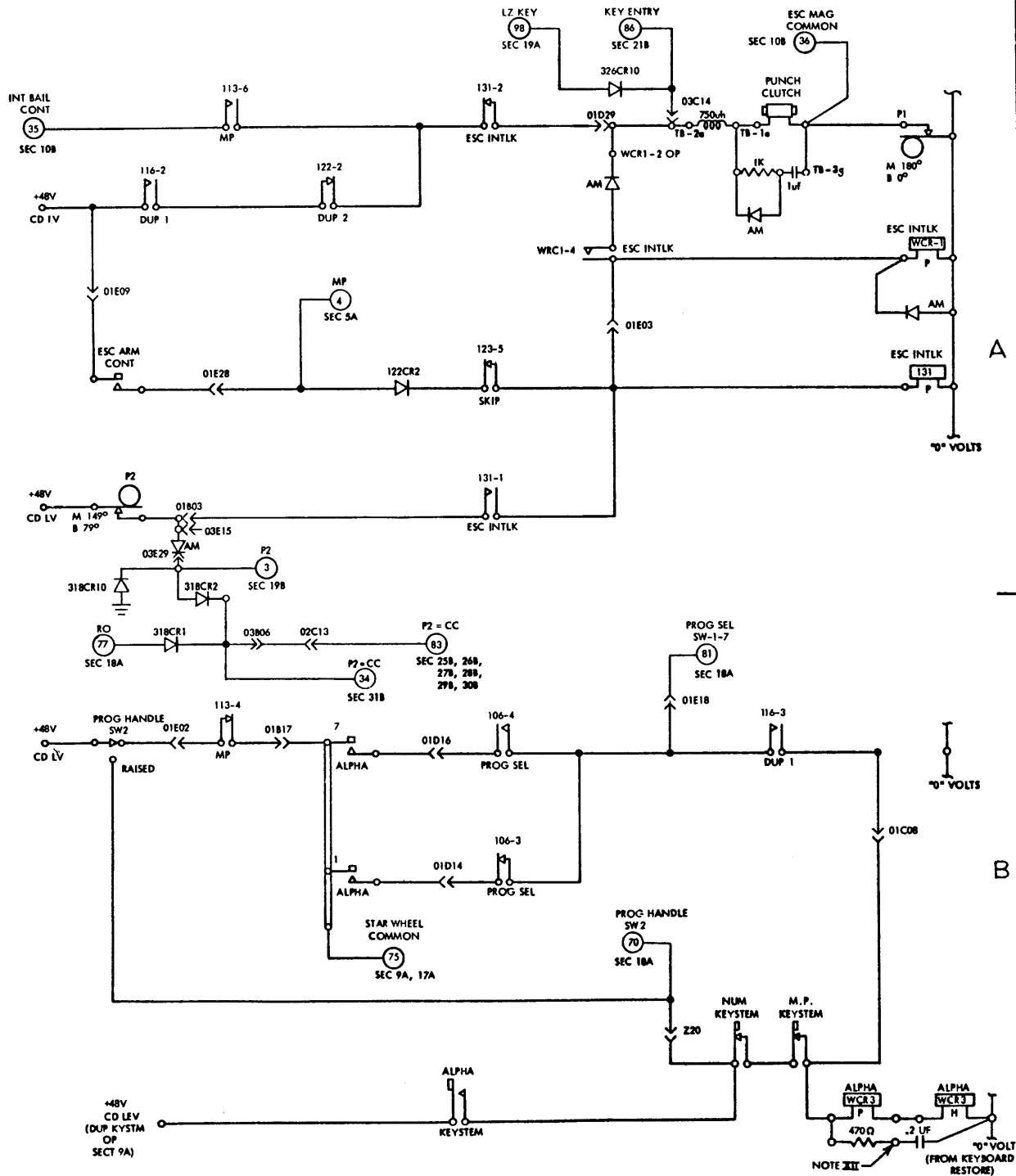

NOTES:
 I POINT TO POINT WIRING FOR +48V AND "0" VOLT NETS SHOWN ON REF PAGE
 II RC ON WCR3 - 1 OP

INTERNATIONAL BUSINESS MACHINES CORP.		DATE	CHANGE NO.	DATE	CHANGE NO.	NOTE	DEVELOPMENT NO.
NAME SYSTEMS DIAGRAM		5-14-65	205293-A			1 PRINT TO ENG. DFDL NO. 895291	01.29.07.1
DETAIL 01.29.07.1		28OCT65	205425-C				
DESIGN BF 3-25-65	MODEL	11APR66	205632				
DETAIL WT 3-25-65							
CHECK RAS 3-25-65	DRAW GT 2-12-65						
APPROV RLJ 3-25-65	CHECK RWL 3-4-65						

5393438

13

REED RELAY
PRINT

14

01.29.08.1

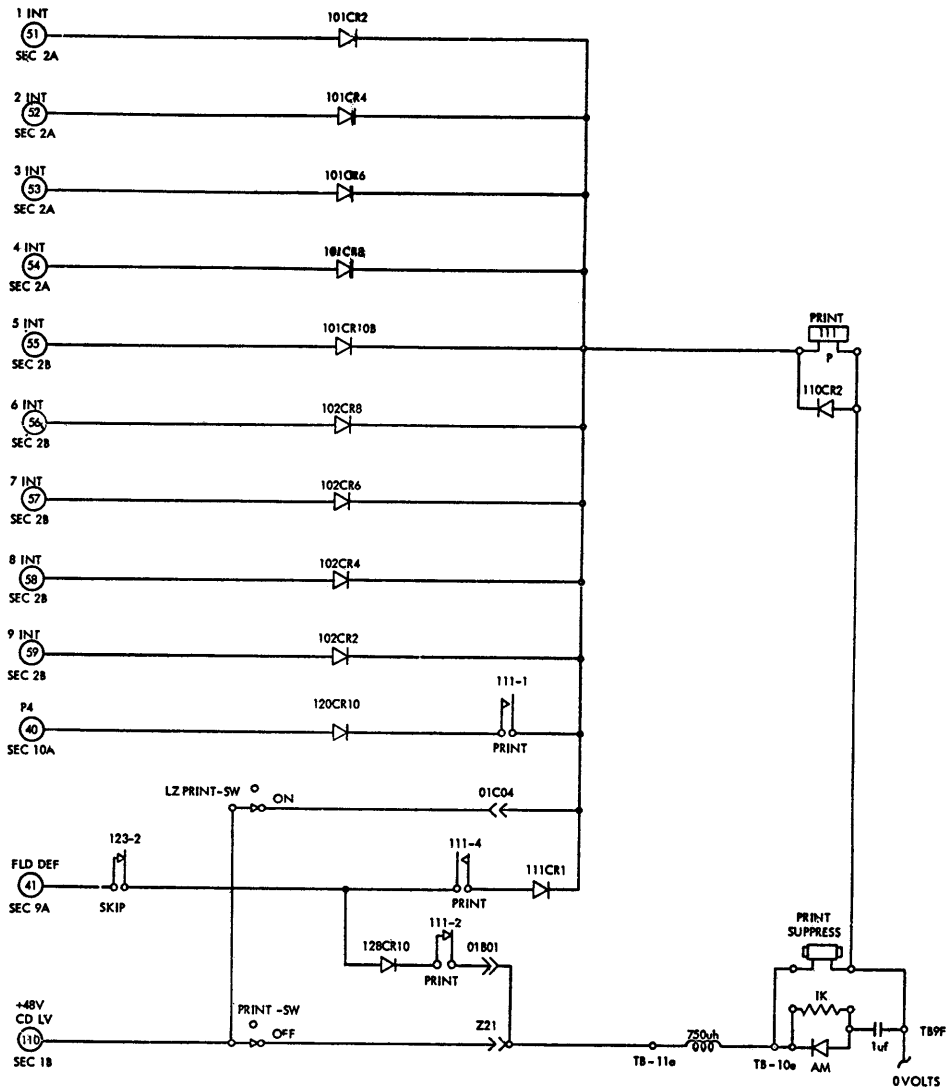

A

B

NOTES:
 XX POINT TO POINT WIRING FOR +48V AND 0V VOLT
 NETS SHOWN ON 01.29.18.0

SIMILAR TO 5373559

INTERNATIONAL BUSINESS MACHINES CORP.		DATE	CHANGE NO.	DATE	CHANGE NO.	NOTE	DEVELOPMENT NO.
NAME SYSTEMS DIAGRAM		5-14-65	205293-A			X PRINT TO ENR. SPG. NO. 895291	5393438
01.29.08.1							
DESIGN BY	3-25-65	MODEL					
DETAIL W/T	3-25-65						
CHECK RAS	3-25-65	DRAW	GY 12-12-65				
APPROV	RLJ 3-25-65	QUANT	R/W 10-2-69				

01.29.08.1

SECTIONS 15 and 16

The wiring diagram page for the Interspersed Gang Punch feature is shown in Sections 15-16.

Refer to Field Engineering Theory-Instruction Manual, *IBM 29 Card Punch Features; 29 Interpreting Card Punch, Model C*, Form 223-2926 for machines having this special feature.

593439

17

REED RELAY KEY ENTRY, FIELD SIZE

18

01.29.09.1

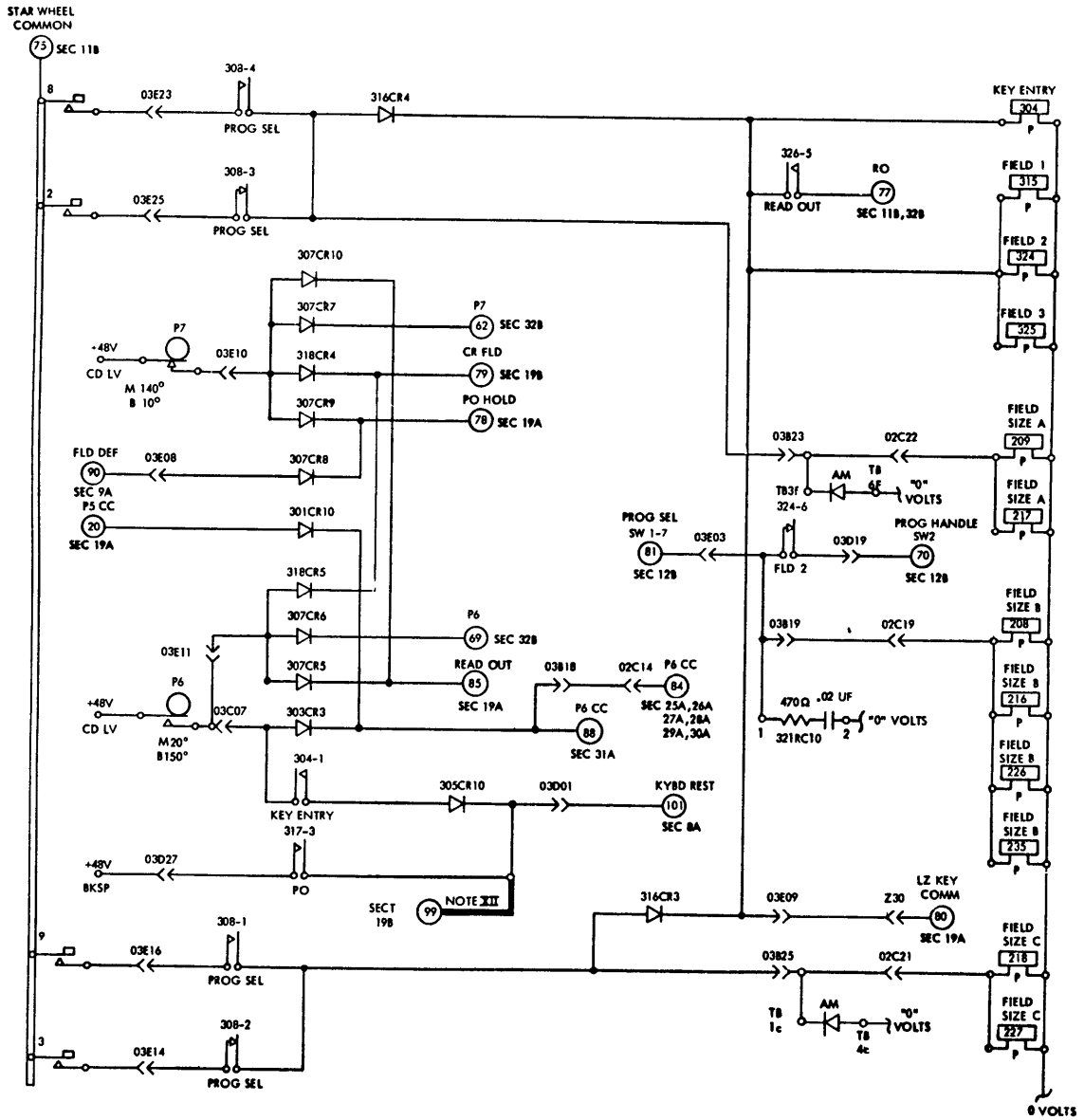

NOTES:
 XI POINT TO POINT WIRING FOR +48V AND "0" VOLT NETS SHOWN ON REF PAGE
 XII CIRCUIT FACTORY INSTALLED APRX DEC 1965

INTERNATIONAL BUSINESS MACHINES CORP.		DATE	CHANGE NO.	DATE	CHANGE NO.	NOTE	DEVELOPMENT NO.
NAME	SYSTEMS DIAGRAM	5-14-65	205293-A			NOTE X PRINT TO ENCL. SPEC. NO. 895291	593439
DESIGN	01.29.09.1	90C163	205425C				
DETAIL	3-25-65	11 MAR 66	205542				
CHECK	3-25-65	11 APR 66	205632				
APPRO	RLJ 3-25-65	CHEK	RWJ 3-4-65				

01.29.09.1

5393440

19

REED RELAY
READ OUT, PUNCH OUT, CREDIT FIELD

20

01.29.10.1

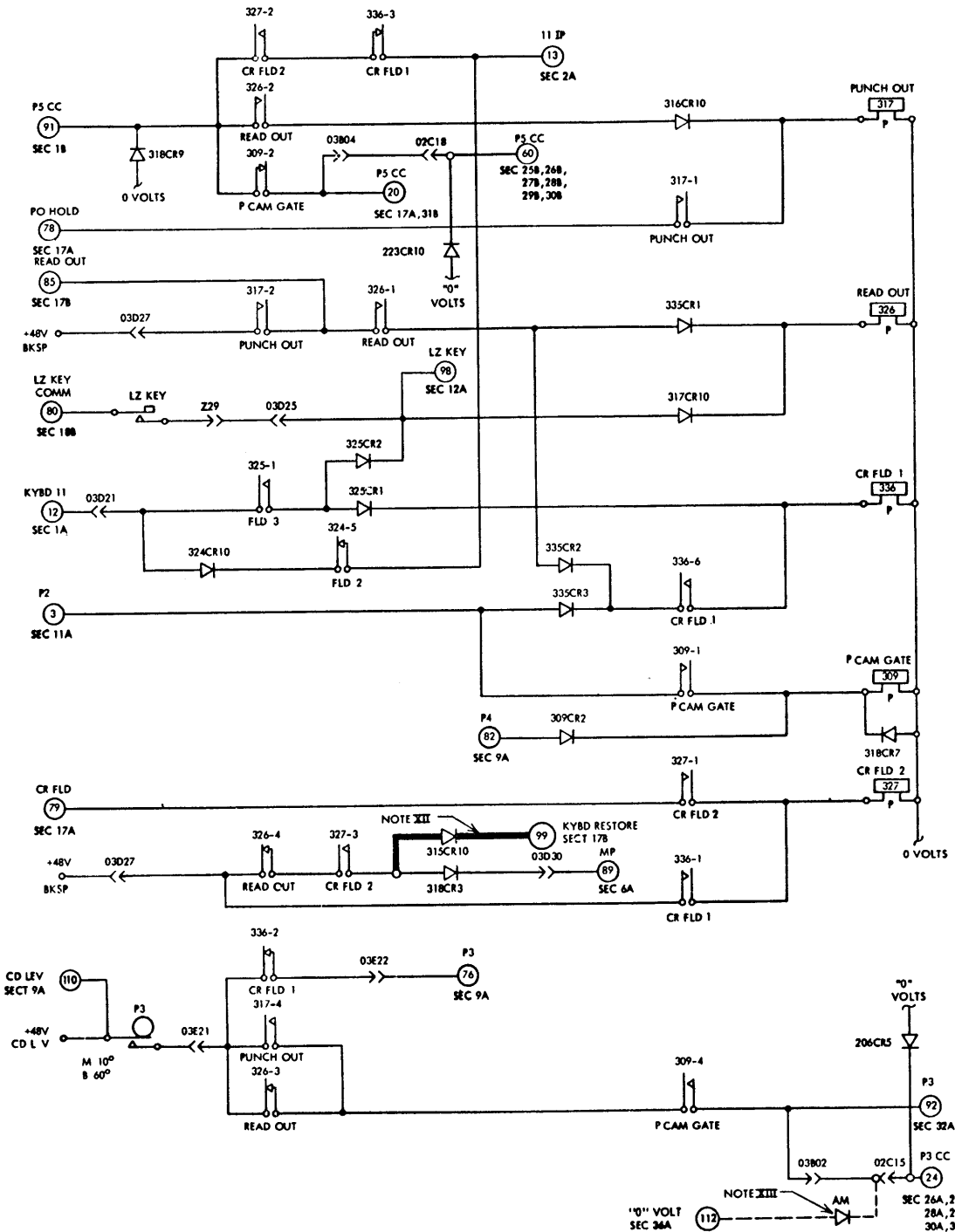

A

B

- NOTES:
- XI POINT TO POINT WIRING FOR +48V AND "0" VOLT NETS SHOWN ON REF PAGE
 - XII 315CR10 FACTORY INSTALLED APRX DEC 1965
 - XIII AM DIODE FACTORY REMOVED APRX FEB 1966

INTERNATIONAL BUSINESS MACHINES CORP.		DATE	CHANGE NO.	DATE	CHANGE NO.	NOTE	DEVELOPMENT NO.
NAME	SYSTEMS DIAGRAM	5-14-65	205293-A			X PRINT TO ENG. SPEG. NO. 895291	5393440
DESIGN	01.29.10.1	9SEP65	205322				
DETAIL	WT 3-25-65	28OCT65	205425 C				
CHECK	RAS 3-25-65	11MAR 66	205542				
APPROV	REL J 3-25-65						

01.29.10.1

5393441

21

REED RELAY FIELD SIZE

22

01.29.11.1

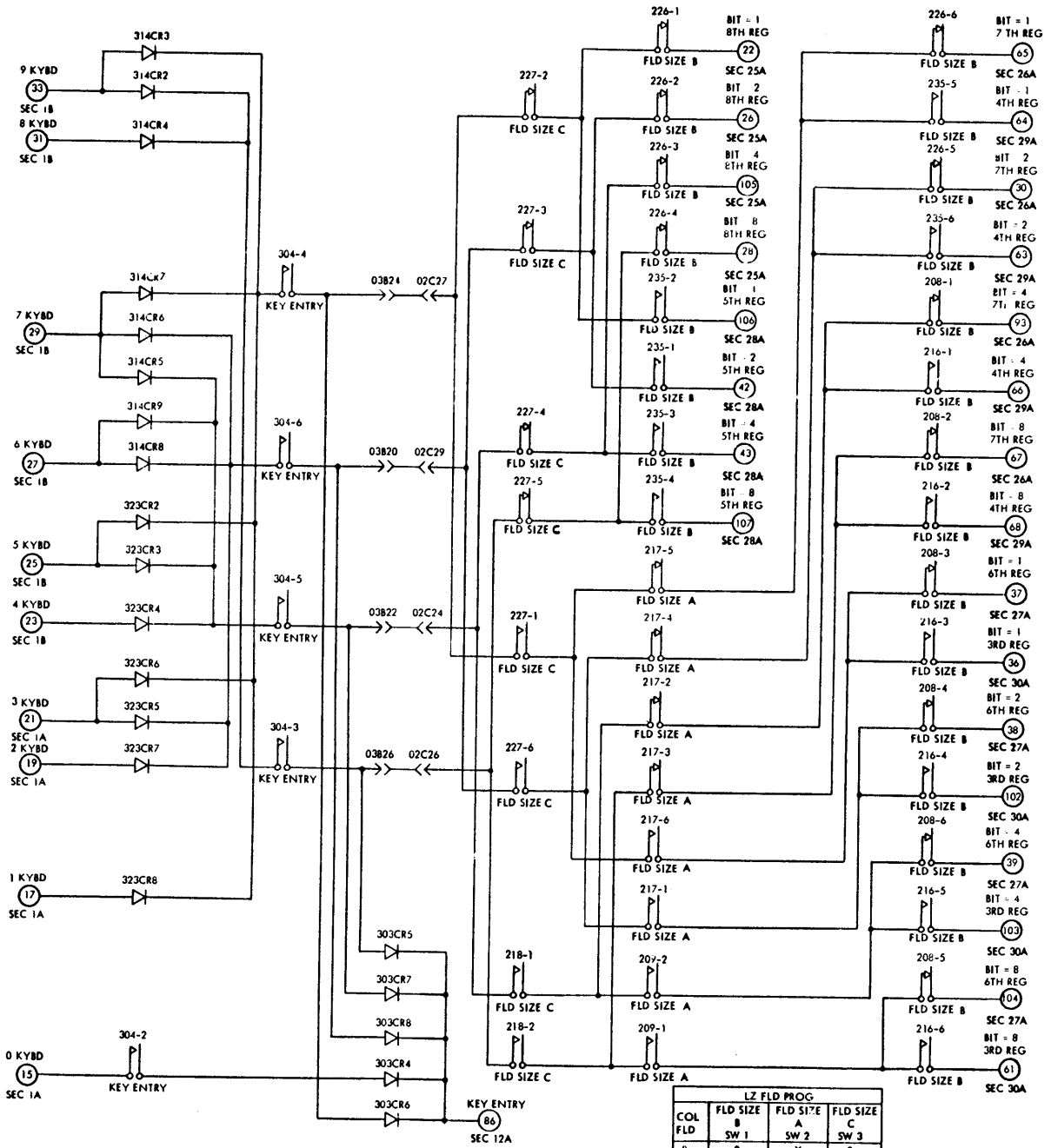

NOTES:
 X POINT TO POINT WIRING FOR +48V AND "0" VOLT NETS SHOWN ON REF PAGE

LZ FLD PROG			
COL FLD	FLD SIZE B SW 1	FLD SIZE A SW 2	FLD SIZE C SW 3
8	0	X	0
7	0	0	X
6	0	X	X
5	X	X	0
4	X	0	X
3	X	X	X

INTERNATIONAL BUSINESS MACHINES CORP.		DATE	CHANGE NO.	DATE	CHANGE NO.	NOTE	DEVELOPMENT NO.
NAME SYSTEMS DIAGRAM		5-14-65	205293-A			# PRINT TO ENCL. SPEC. NO. 895291	01.29.11.1
DESIGN BF 3-25-65 MODEL		280CT85	20542-C				
DETAIL WT 3-25-65							
CHECK RAS 3-25-65 DRAW GT 2-12-65							
APPRO RLJ 3-25-65 CHECK RWE 3-4-65							

5393442

23

REED RELAY TREE

24

01.29.12.1

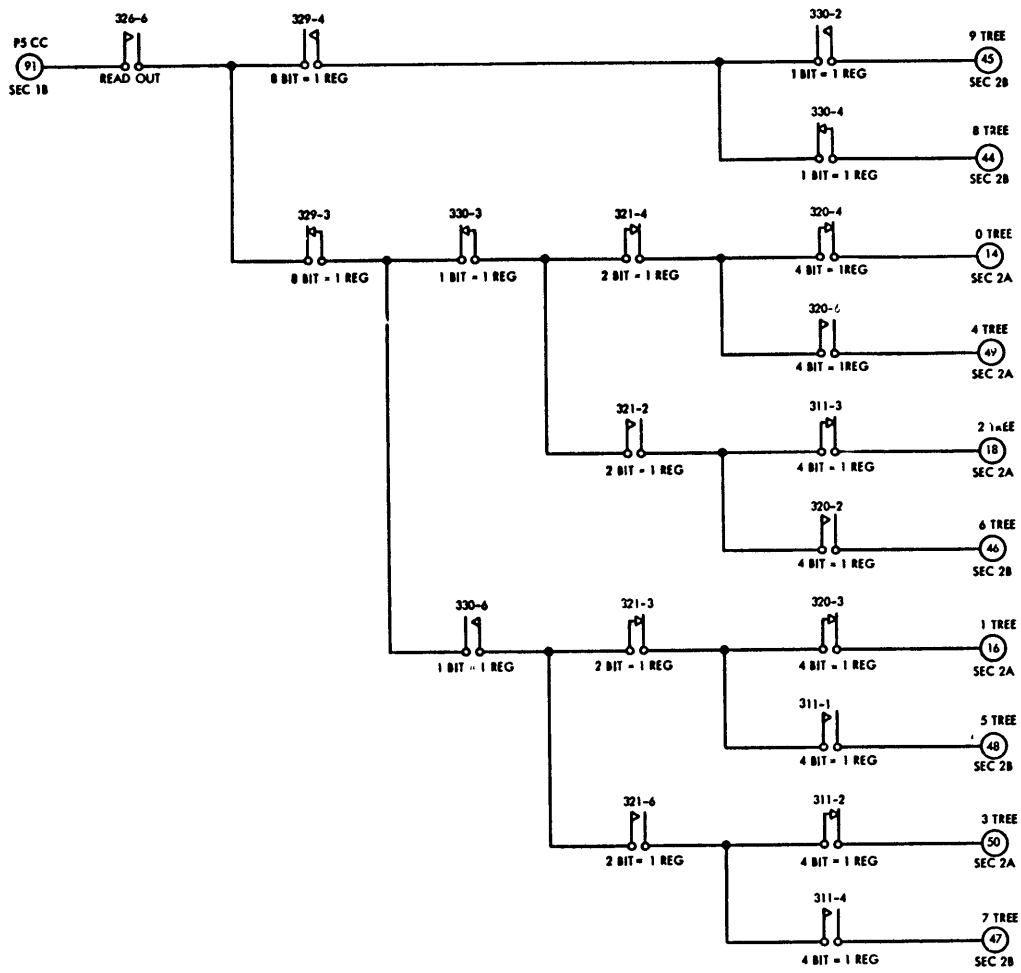

A

B

INTERNATIONAL BUSINESS MACHINES CORP.		DATE	CHANGE NO.	DATE	CHANGE NO.	NOTE	DEVELOPMENT NO.
NAME SYSTEMS DIAGRAM		5-14-65	205293-A			X PRINT TO ENG. DEPT. NO. 895291	5393442
01.29.12.1							
DESIGN	BF 3-25-65						
DETAIL	WT 3-25-65						
CHECK	RAS 3-25-65						
APPRO	RL 3-25-65						
							01.29.12.1

5393443

25
8TH REGISTER

REED RELAY
TREE

26
7TH REGISTER

01.29.13.1

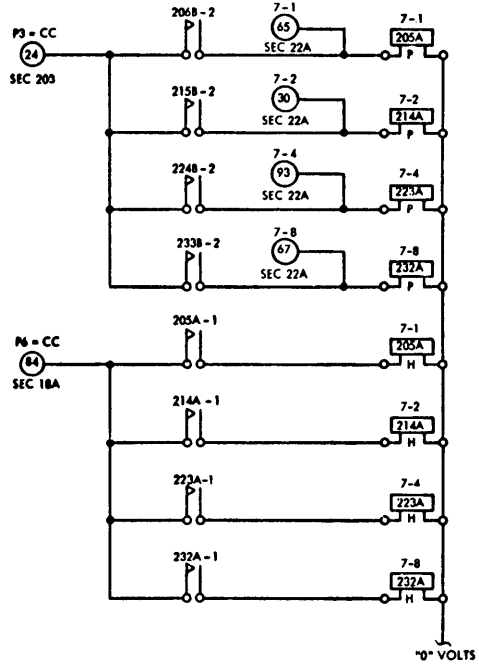
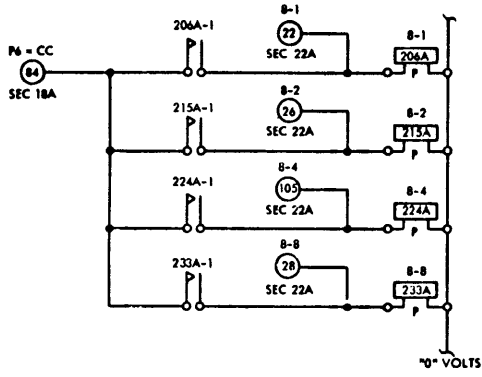

A

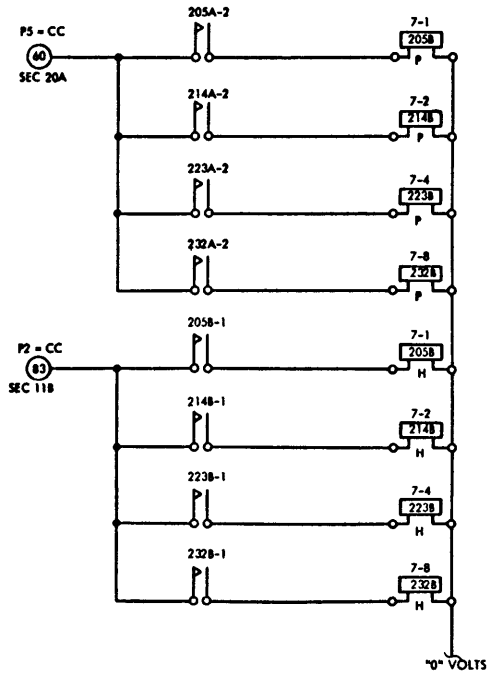
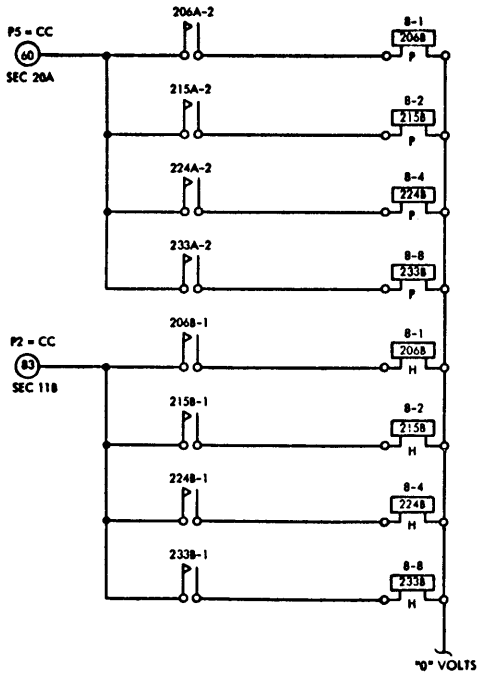

B

INTERNATIONAL BUSINESS MACHINES CORP.		DATE	CHANGE NO.	DATE	CHANGE NO.	NOTE	DEVELOPMENT NO.
NAME	SYSTEMS DIAGRAM	5-14-65	205293-A			I PRINT TO ENG. SPEC. NO. 895291	01.29.13.1
DESIGN	01.29.13.1						
DETAIL	3-25-65						
CHECK	RAS 3-25-65	DRAW	GT 2-12-65				
APPRO	RLJ 3-25-65	CHECK	RVL 3-4-65				

5393443

5393444

27
6TH REGISTER

REED RELAY TREE

28
5TH REGISTER

01.29.14.1

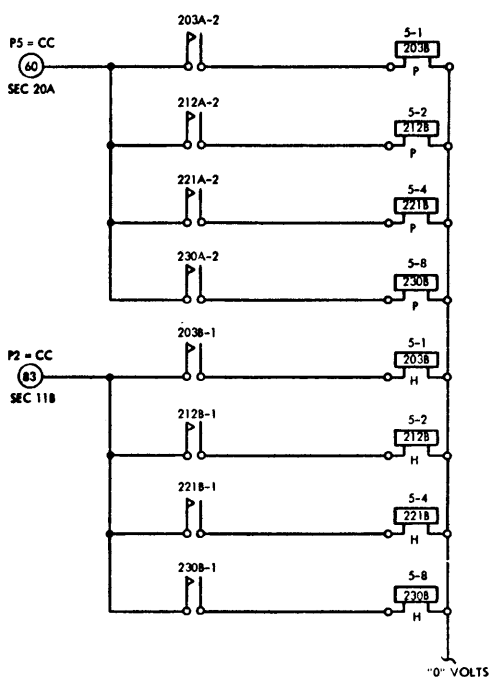
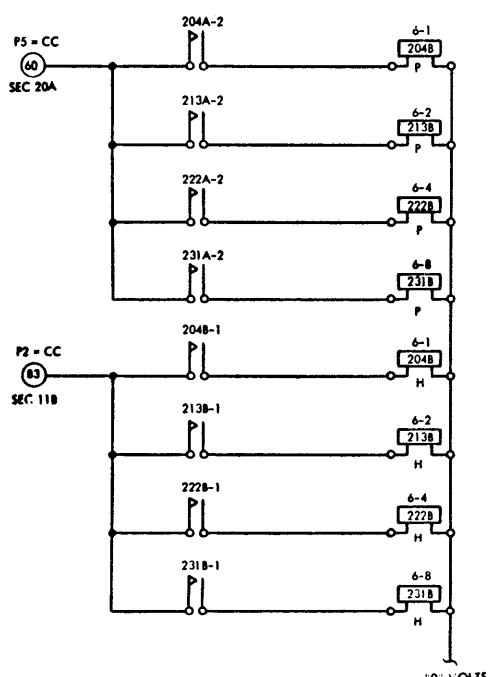
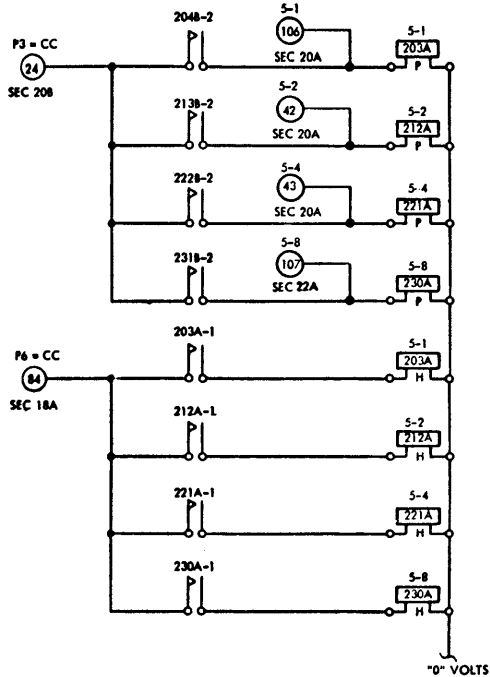
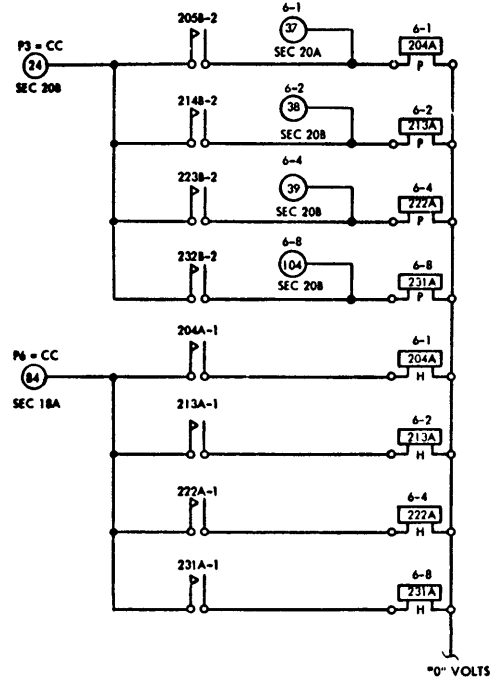

A

B

INTERNATIONAL BUSINESS MACHINES CORP.		DATE	CHANGE NO.	DATE	CHANGE NO.	NOTE	DEVELOPMENT NO.
NAME	SYSTEMS DIAGRAM	5-14-65	205293-A			NOTE X PRINT TO ENL. SPEC. NO. 895291	5393444
	01.29.14.1	28OCT65	205425-C				
DESIGN	BF 3-25-65						
DRAWN	WJ 3-25-65						
CHECK	RAS 3-25-65						
APPROV	RLT 3-25-65						
	CHECKER						

01.29.14.1

5393445

29
4TH REGISTER

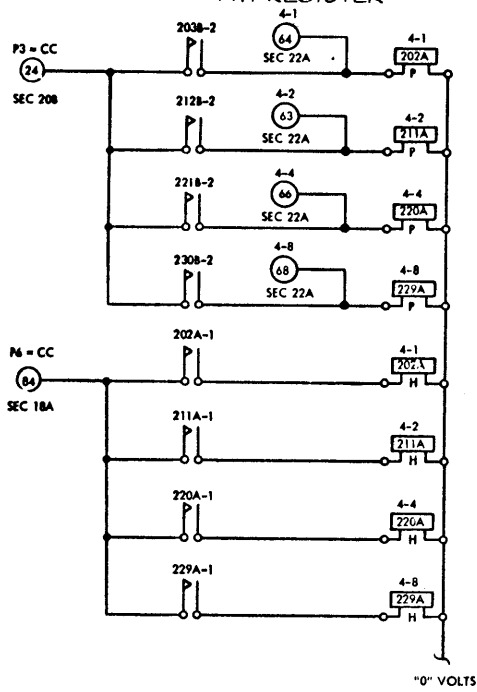

REED RELAY TREE

30
3RD REGISTER

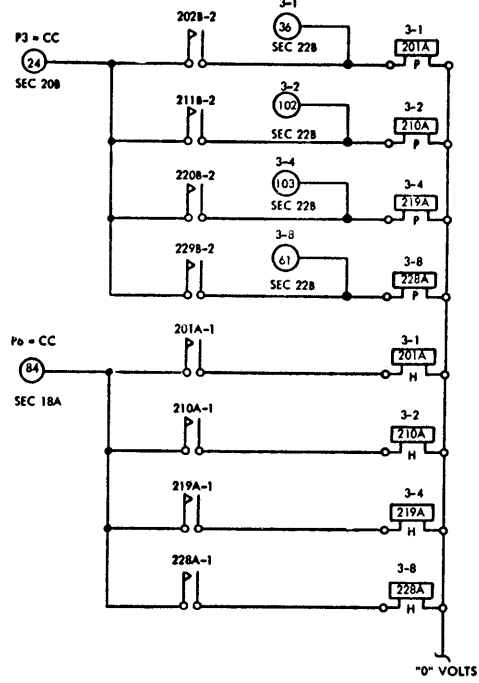

01.29.15.1

A

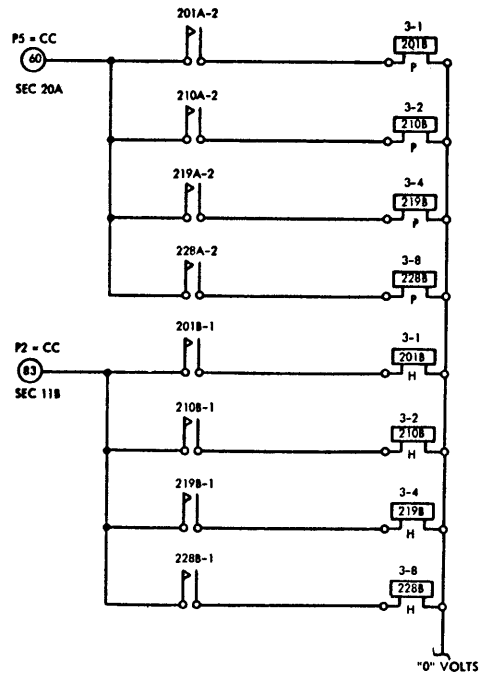
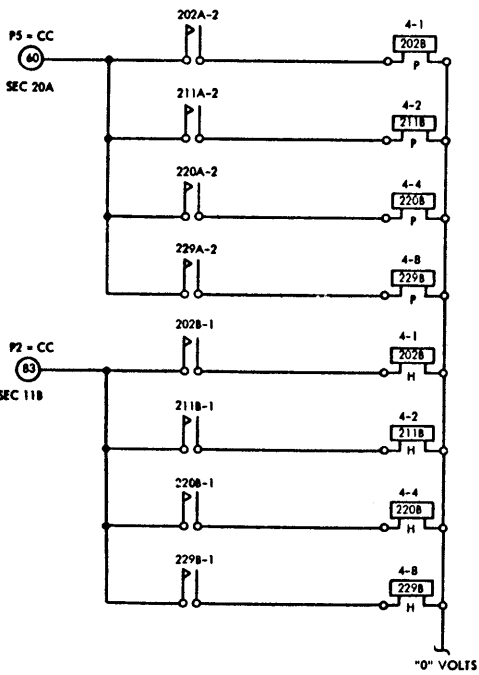

B

INTERNATIONAL BUSINESS MACHINES CORP.		DATE	CHANGE NO.	DATE	CHANGE NO.	NOTE	DEVELOPMENT NO.
NAME SYSTEMS DIAGRAM		5-14-65	205293 -A			* PRINT TO ENL. SPEC. NO. 895291	5393445 01.29.15.1
DESIGN BF 3-25-65 MODEL							
DETAIL WT 3-25-65							
CHECK RAS 3-25-65 DRAW GT 2-12-65							
APPRO REL 3-25-65 CHECK RWJ 13 4 65							

5393446

01.29.16.1

31
2ND REGISTER

REED RELAY
TREE

32
1ST REGISTER

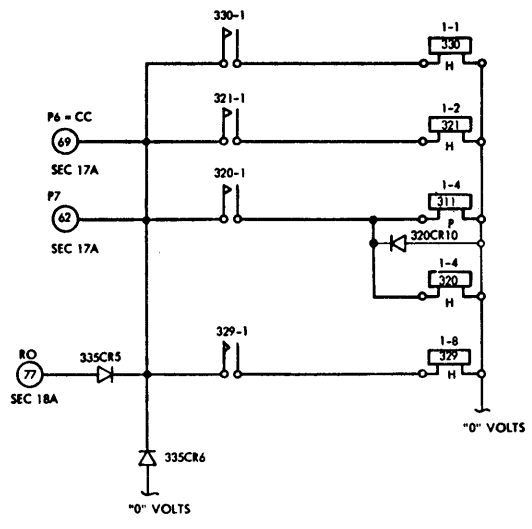
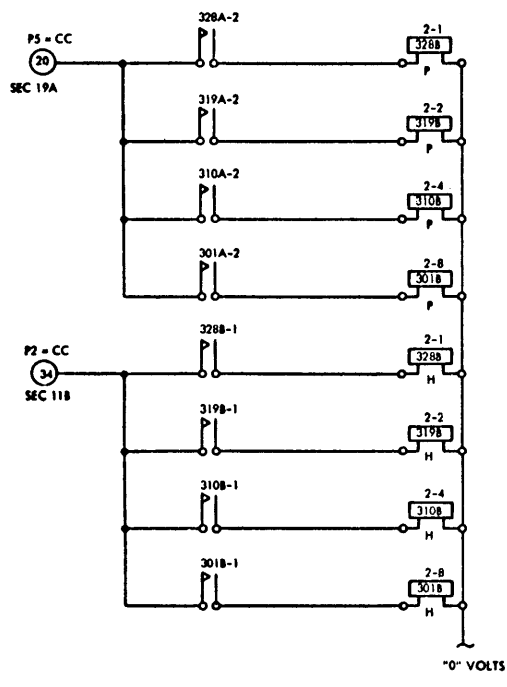
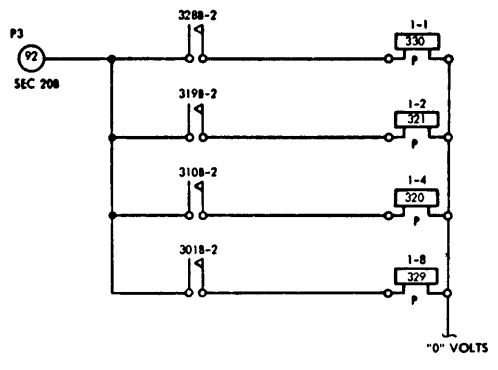
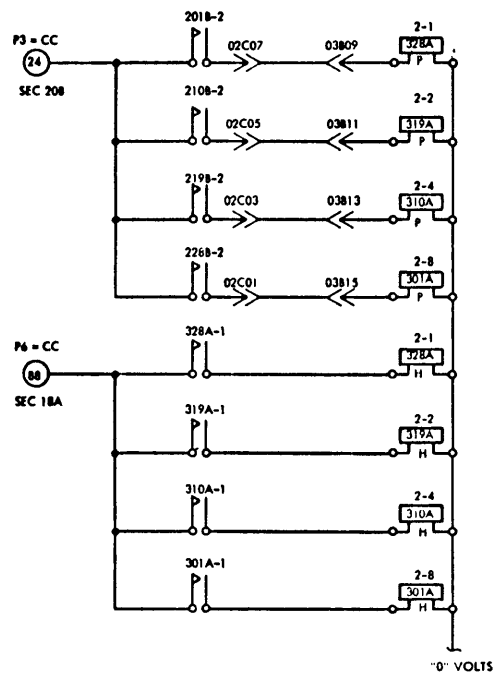

INTERNATIONAL BUSINESS MACHINES CORP.				DATE	CHANGE NO.	DATE	CHANGE NO.	NOTE	DEVELOPMENT NO.
NAME	SYSTEMS DIAGRAM			5-14-65	203293-A			NOTE 1. PRINT TO ENL. SPC. NO. 895291	0393446
DESIGN	BF	3-25-65	MODEL						
DETAIL	WT	3-25-65							
CHECK	RAS	3-25-65	DRAW	GT	2-17-65				
APPRO	KL	3-25-65	CHECK	WJ	3-4-65				
									01.29.16.1

530347

NAME	RELAY NO.	COIL		CONTACTS						PART NO.
		F	H	1	2	3	4	5	6	
CD LV	124	10A		9B						766096
PROG SEL	106	8A		9A	9A	11B	11B			766073
CLEAR 1	107	8B		6B	6A	5A	6A	5A	6B	766076
CLEAR 2	108	6A		5A	5A	6B				766075
CARD LEVER	110	8B		9B		8A	5A		6B	766073
PRINT	111	14A		14B	14B					766073
CARD LEVER	112	8B		7B		9B	5A	1A	9A	766076
MULTI PUNCH	113	6A		5A	10A	9B	11B	10B	11A	766075
DUP 1	114	10A		7B	9B	9B	10A			NOTE XI
PROG SEL	115	8A		8A	9B	9B	9A	9A	8A	766076
DUP 1	116	10A		10A	11A	12B	10A			766071
SKIP	117	10A		7A						NOTE XIII
DUP 2	120	10A		1B	10A	10A				766071
RELEASE	121	6B		10B	6B	5A		7B	9B	NOTE XII
DUP 2	122	10A		9B	11A	6A	10A			NOTE XI
SKIP	123	10B		9A	13B	10B	10A	11A	9B	766075
ESC INTRK	131	12A		11A	11A		9A	10A	10B	766075
1 BIT = 3RD REG	201A	30A	30A	30A	30B					766087
1 BIT = 3RD REG	201B	30B	30B	30B	31A					766087
1 BIT = 4TH REG	202A	29A	29A	29A	29B					766087
1 BIT = 4TH REG	202B	29B	29B	29B	30A					766087
1 BIT = 5TH REG	203A	28A	28A	28A	28B					766087
1 BIT = 5TH REG	203B	28B	28B	28B	29A					766087
1 BIT = 6TH REG	204A	27A	27A	27A	27B					766087
1 BIT = 6TH REG	204B	27B	27B	27B	28A					766087
1 BIT = 7TH REG	205A	26A	26A	26A	26B					766087
1 BIT = 7TH REG	205B	26B	26B	26B	27A					766087
1 BIT = 8TH REG	206A	25A	25A	25A	25B					766087
1 BIT = 8TH REG	206B	25B	25B	25B	26A					766087
FIELD SIZE	208	18A		22A	22A	22B	22B	22B	22B	766072
2 BIT = 3RD REG	210A	30A	30A	30A	30B					766072
2 BIT = 3RD REG	210B	30B	30B	30B	31A					766072
2 BIT = 4TH REG	211A	29A	29A	29A	29B					766072
2 BIT = 4TH REG	211B	29B	29B	29B	30A					766072
2 BIT = 5TH REG	212A	28A	28A	28A	28B					766072
2 BIT = 5TH REG	212B	28B	28B	28B	29A					766072
2 BIT = 6TH REG	213A	27A	27A	27A	27B					766072
2 BIT = 6TH REG	213B	27B	27B	27B	28A					766072
2 BIT = 7TH REG	214A	26A	26A	26A	26B					766072
2 BIT = 7TH REG	214B	26B	26B	26B	27A					766072
2 BIT = 8TH REG	215A	25A	25A	25A	25B					766072
2 BIT = 8TH REG	215B	25B	25B	25B	26A					766072
FIELD SIZE	216	18A		22A	22A	22B	22B	22B	22B	766072
FIELD SIZE	217	18A		22B	22B	22B	22B	22A	22B	766075
FIELD SIZE	218	18B		22B	22B					766072
4 BIT = 3RD REG	219A	30A	30A	30A	30B					766072
4 BIT = 3RD REG	219B	30B	30B	30B	31A					766072
MCI	119	6A		6A	7B	7B	5A	7A		766075
AUX DUP	130	2B		2B						766073
HSS-1-2										NOTE XVI

NAME	RELAY NO.	COIL		CONTACTS						PART NO.	
		F	H	1	2	3	4	5	6		
4 BIT = 4TH REG	220A	29A	29A	29A	29B					766087	
4 BIT = 4TH REG	220B	29B	29B	29B	30A					766087	
4 BIT = 5TH REG	221A	28A	28A	28A	28B					766087	
4 BIT = 5TH REG	221B	28B	28B	28B	29A					766087	
4 BIT = 6TH REG	222A	27A	27A	27A	27B					766087	
4 BIT = 6TH REG	222B	27B	27B	27B	28A					766087	
4 BIT = 7TH REG	223A	26A	26A	26A	26B					766087	
4 BIT = 7TH REG	223B	26B	26B	26B	27A					766087	
4 BIT = 8TH REG	224A	25A	25A	25A	25B					766087	
4 BIT = 8TH REG	224B	25B	25B	25B	26A					766087	
FIELD SIZE	226	18B		22A	22A	22A	22A	22A	22A	766073	
FIELD SIZE	227	18B		22B	22A	22A	22A	22A	22B	766073	
8 BIT = 3RD REG	227A	30A	30A	30A	30B					766087	
8 BIT = 3RD REG	227B	30B	30B	30B	31A					766087	
8 BIT = 4TH REG	228A	29A	29A	29A	29B					766087	
8 BIT = 4TH REG	228B	29B	29B	29B	30A					766087	
8 BIT = 5TH REG	229A	28A	28A	28A	28B					766087	
8 BIT = 5TH REG	229B	28B	28B	28B	29A					766087	
8 BIT = 6TH REG	230A	27A	27A	27A	27B					766087	
8 BIT = 6TH REG	230B	27B	27B	27B	28A					766087	
8 BIT = 7TH REG	231A	26A	26A	26A	26B					766087	
8 BIT = 7TH REG	231B	26B	26B	26B	27A					766087	
8 BIT = 8TH REG	232A	25A	25A	25A	25B					766087	
8 BIT = 8TH REG	232B	25B	25B	25B	26A					766087	
FIELD SIZE	235	18B		21A	21A	22A	22A	22A	22A	766070	
8 BIT = 2ND REG	301A	31A	31A	31A	31B					766087	
8 BIT = 2ND REG	301B	31B	31B	31B	32A					766087	
KEY ENTRY	304	18A		17B	21B	21B	21A	21B	21A	766070	
PROG SFL	308	8A		17B	17B	17A	17A			766073	
P CAM GATE	309	20B		20B	19A	20B				766072	
4 BIT = 2ND REG	310A	31A	31A	31A	31B					766087	
4 BIT = 2ND REG	310B	31B	31B	31B	32A					766087	
4 BIT = 1ST REG	311	32B		24B	24B	24A	24B			766073	
FIELD 1	315	18A		1B	1B	1B	1B	1B	1A	766093	
PUNCH OUT	317	20A		20A	19A	17B	19B			766070	
2 BIT = 2ND REG	319A	31A	31A	31A	31B					766087	
2 BIT = 2ND REG	319B	31B	31B	31B	32A					766087	
4 BIT = 1ST REG	320	32A	32B	32B	24A	24A	24A	24A	24A	766078	
2 BIT = 1ST REG	321	32A	32B	32B	24A	24A	24A	24A	24B	766078	
FIELD 2	324	18A		1A	1A	1A	1A	1A	19A	18A	766083
FIELD 3	325	18A		19A							766072
READ OUT	326	20A		19A	19A	19B	19B	18A	23A	766074	
CK FIELD 2	327	20B		20B	19A	19B				766071	
1 BIT = 2ND REG	328A	31A	31A	31A	31B					766087	
1 BIT = 2ND REG	328B	31B	31B	31B	32A					766087	
8 BIT = 1ST REG	329	32A	32B	32B	23A	23A	23A	23A	23A	766077	
4 BIT = 1ST REG	330	32A	32B	32B	24A	24A	24A	24A	24A	766078	
CK FIELD 1	336	20A		20B	19B	19A			20A	766073	

NOTE XIX, 2391158 DIODES

RECT NO.	SEC
101CR1	2A
101CR2	13A
101CR3	2A
101CR4	13A
101CR5	2A
101CR6	13A
101CR7	2B
101CR8	13A
101CR9	2B
101CR10A	8A
101CR10B	13A
102CR1	2A
102CR2	13A
102CR3	2B
102CR4	13A
102CR5	2B
102CR6	13A
102CR7	2B
102CR8	13A
102CR9	2B
102CR3	2A
102CR7	2A
102CR8	7A
102CR1	7A
102CR5	8A
102CR1	6A
102CR10	8A
102CR10	5B
110CR2	14A
110CR10	8A
111CR1	14B
113CR10	5A
115CR2B	8A
116CR1	6B
116CR2	6B
117CR1	8B
117CR2	8B

NOTE XXII

RECT NO.	SEC
117CR3	6A
117CR5	6A
119CR10	6A
120CR1	6B
120CR10	13B
122CR1	10A
122CP2	11A
122CR10	12A
123CR10B	10A
124CP3	7B
124CR4	9B
124CP8	9A
124CP9	10B
128CR10	13B
129CR4	10A
130CR10B	10A
132CR1	7A
132CR5	6B
132CR8	10B
132CR1	5B
134CR10	10B
301CR10	17A
303CR3	17B
303CR4	21B
303CR5	21B
303CR6	21B
303CR7	21B
303CR8	21B
305CR10	17B
307CR5	17A
307CR6	17A
307CR7	17A
307CR8	17A
307CR9	17A
307CR10	17A
308CR1	6A

NOTE XXIII, 2391158 DIODES

RECT NO.	SEC
308CR2	1B
309CR1	9A
309CR2	20B
314CR2	21A
314CR3	21A
314CR4	21A
314CR5	21A
314CR6	21A
314CR7	21A
314CR8	21A
314CR9	21A
316CR3	18B
316CR4	17A
316CR10	20A
317CR10	20A
318CR10	11A
319CR1	11B
319CR2	11A
319CR3	19B
319CR4	17A
319CR7	20B
319CR5	17A
320CR10	20B
318CR9	19A
323CR2	21A
323CR3	21A
323CR4	21B
323CR5	21B
323CR6	21B
323CR7	21B
323CR8	21B
324CR10	19A
325CR1	19A
325CR2	19A
326CR10	12A
335CR1	20A
335CR2	20A
335CR3	20A
335CR5	32B
335CR6	32B
206CR5	20B
223CR10	19A

NOTE XXIV, 2391158 DIODES

RECT NO.	SEC
308CR2	1B
309CR1	9A
309CR2	20B
314CR2	21A
314CR3	21A
314CR4	21A
314CR5	21A
314CR6	21A
314CR7	21A
314CR8	21A
314CR9	21A
316CR3	18B
316CR4	17A
316CR10	20A
317CR10	20A
318CR10	11A
319CR1	11B
319CR2	11A
319CR3	19B

5393448

01.29.18.0

35 + 48 VOLTS NET

REED RELAY

36 0 VOLTS NET

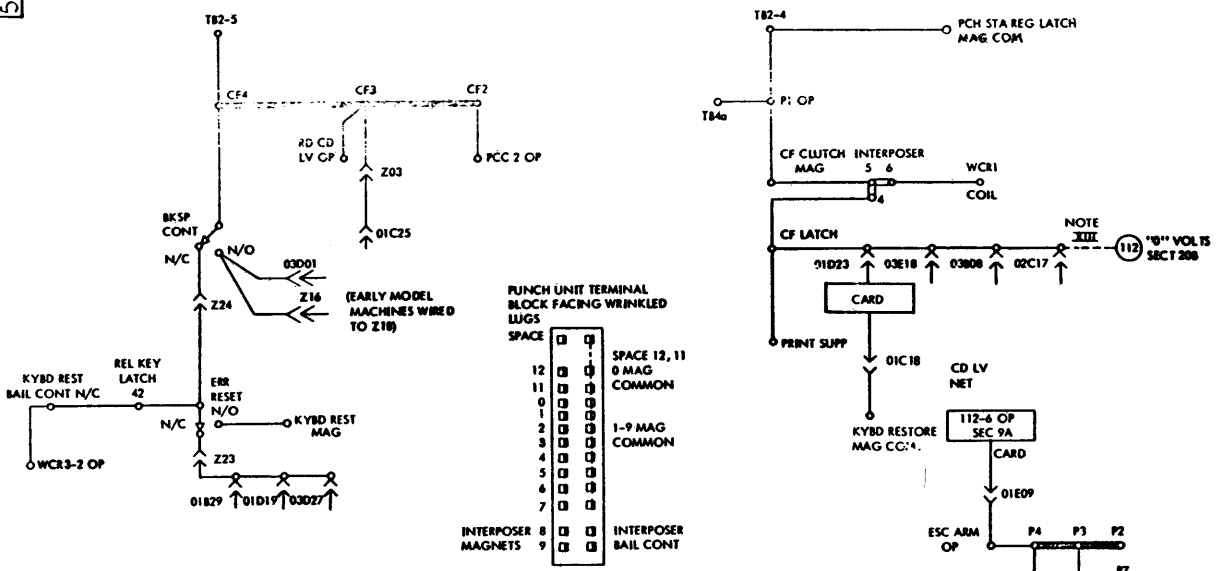

PUNCH UNIT TERMINAL BLOCK FACING WRINKLED LUGS

SPACE	12	11	10	9	8	7	6	5	4	3	2	1
	□	□	□	□	□	□	□	□	□	□	□	□
	12	11	10	9	8	7	6	5	4	3	2	1
	□	□	□	□	□	□	□	□	□	□	□	□
	12	11	10	9	8	7	6	5	4	3	2	1
	□	□	□	□	□	□	□	□	□	□	□	□
	12	11	10	9	8	7	6	5	4	3	2	1
	□	□	□	□	□	□	□	□	□	□	□	□
	12	11	10	9	8	7	6	5	4	3	2	1
	□	□	□	□	□	□	□	□	□	□	□	□
	12	11	10	9	8	7	6	5	4	3	2	1
	□	□	□	□	□	□	□	□	□	□	□	□

SPACE 12, 11 0 MAG COMMON
1-9 MAG COMMON
INTERPOSER 8 INTERPOSER BAIL CONT
MAGNETS 9

CONNECTOR CHART

PN	1A	1B	1C	1D	1E	2C	3B	3C	3D	3E	Z
1		1A				31A	2B	1B			1A
2	4A	2A			11B	20B					35A
3	7A	11A	6A**		12A	31A	2B	1A	18A		1A
4	2A	2B	14B	8A		31A	19A				1A
5			5A	9B							1A
6	2A	1B	1A	7A		31A	11B	1B	1A		1A
7	6A		6B					17B	1A		1A
8	2A	2B	12B	6A	6A	35A			17A	1A	
9	5A		2B**		11A			1A	18B	1B	
10	2B	2B	1A	9A	5A			2B	17A	1B	
11	7B	2F**	1B	9B	9A		31A		1B	17A	1B
12	2B	2A	5A	9A	5B			2B	1B	1A	
13	6A**	2B	5A	9B	10A	11B	31A		1B	1B	
14	2B	2B	1A	11B	18A		12A	1B	17B	6A	
15	9B	9B	6A	7A		20B	31A	2A	1B	17B	8B
16	2A	2B	1A	11B	5B			2A	1B	17B	8B
17	1B	11B	9A	9A		34A			1B	17A**	
18	2A	2A			12B	19A	18A	2A		36A	8B
19			1A	8A		16A	11A		18A	8A	1B
20	2A	5B	10A		5B		21A	2A	1B	17B	
21	7B		9B	9B	10A	11A		19A	19B	14B	
22	2A	2A	7A	8A		18A	71B	2A	19B	9B	
23	5A		8B	36A	5B		16A	1A	17A	35A	
24	9B	2A	6A	10B		21B	71F	2A	9A	35A	
25		1B	6A	6A			19A	17A			
26	7B		7A**		8B	21B	21B		17B	16A	5B
27	7A**	9B	9A			21A					
28	7B	2A	5A	9A	11A			2B		2B**	
29	8A	5A	9B	12A	21A				11A	19A	
30	2B		7A				2A	20B		18B	

REED RELAY DATA

PART NO.	COIL	1	2	3	4	5	6
766070/765098	1940	N/O	N/O	N/O	N/O	N/O	N/O
766071/765100	3460	N/O	N/O	N/O	N/O	N/O	N/O
766072/765221	5735	N/O	N/O				
766073/765222	3460	N/O	N/C	N/C	N/O		
766074/765224	P 3045	N/O	N/C	N/C	N/O		
766077/765224	H 3500	N/O	N/C	N/C	N/O		
766075/765225	1940	N/O	N/C	N/C	N/O		
766076/765226	1940	N/O	N/O	N/C	N/C	N/O	N/O
766078/765229	P 1815	N/O	N/O	N/C	N/C	N/O	N/O
766079/765229	H 3085	N/O	N/O	N/C	N/C	N/O	N/O
766080/765230	1940	N/C	N/C	N/C	N/C	N/O	N/O
766080/765235	7715	N/O	N/O	N/C	N/C	N/O	N/O
766082/765232	P 4500	N/O	N/O				
766080/765232	H 5700	N/O	N/O				

CARD FEED (CF) CAMS

NO.	LOC.	PART NO.	M	B
2	5B	309630	350° ± 2	110° ± 5
3	7B	309631	70° ± 2	150° ± 5
4	7A	309631	16° ± 2	96° ± 5

CAPACITORS

CAP	SFC	PART NO.
128C4	1B	212317
134C1	10B	432145

PUNCH (P) CAMS

NO.	LOC.	PART NO.	M	B
1	12A	309630	180° ± 1	0° ± 3
2	11A	309634	140° ± 3	70° ± 2
3	19B	227104	10° ± 1	60° ± 3
4	9A	309630	172° ± 3	355° ± 2
5	1B	309622	80° ± 3	160° ± 2
6	17A	326422	210° ± 2	150° ± 5
7	12A	308734	140° ± 5	10° ± 2

RESISTORS

RESISTORS	SEC	PART NO.
128R1	1B	317428
112R10	8A	597682
134R4	10B	317014
128R4	2B	301149
31RC	18R	5404074

ARC SUPP ASSEMBLIES NOTE XI

MAG	ARC SUPP	PART NO.
DIODE ASM		540137
KYBD REST BAIL CONT		537234B 1A
INDUCTOR ASM		5400916
CAPACITOR		5400939
CD FD CLUTCH MAG		2160917 6A
RESISTOR ASM		5409798
ESC INTLK BLY		342820 12
CAPACITOR (SHORT LEAD) ASM		5400890
AM DIODE		5401043 20B
CAPACITOR ASM		315562
RESISTOR ASM		112186

CONNECTOR DIODE NOTE XIII

PART NO.	TYPE OF TERMINAL
5404119	SLIP ON
5401043	TAB

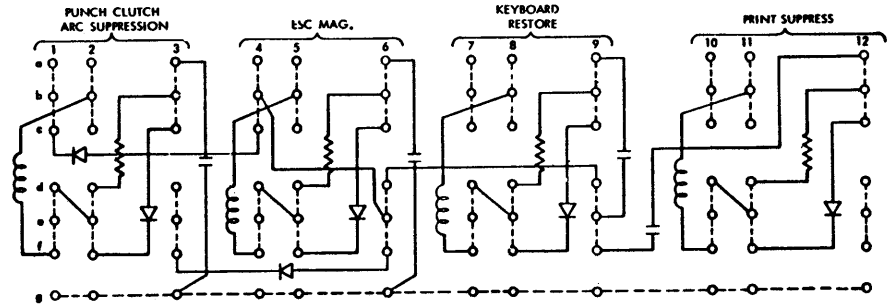

NOTES

XI ARC SUPPRESSION ASSEMBLIES WITHOUT LOCATIONS ARE LOCATED ON ARC SUPPRESSION TB

XII THESE POINTS DO NOT APPEAR ON STANDARD PAGES THEY APPEAR ONLY ON FEATURE PAGES

XIII CIRCUIT FACTORY REMOVED FEB 1968

XIV CHECK TYPE OF CONNECTOR BEFORE SELECTING DIODE ASM

NAME	DATE	CHANGE NO.	DATE	CHANGE NO.	NOTE	DEVELOPMENT NO.
SYSTEMS DIAGRAM	5-14-65	205293-A				
01.29.18.0	9SEP65	205322				
DESIGN WF 3-25-65	MODEL	280CT45				
DRAW WT 3-25-65	DRW GT 2-12-65	11712.66				
CHECK RAS 3-25-65	CHECK FWL 3-4-65	11APR66				
APPROV						

5393448

01.29.18.0

537356

00.29.10.0

KEYBOARD & CAM REFERENCE

STEM POS	GRAPHIC		CARD CODE		BAILS		LATCHES	
	ALPHA	NUMERIC	ALPHA	NUMERIC	ALPHA	NUMERIC	ALPHA	NUMERIC
1	ERROR	RESET						
2	MULTI	PUNCH						
3		NUMERIC						
4	Q	+	11-8	12-8-6	13,9	12,8,6		
5	A		12-1		15,3			
6	@	#	8-4	8-3	9,7	8,2		
7	Z		0-9		1,11			
8	W	-	0-6	0-8-5	14	14,8,4	X	
9	S	>	0-2	0-8-6	14	14,8,6	X	
10	%		0-8-4	0-8-3	14,9,7	14,8,2		
11	X	?	0-7	0-8-7	14	14,8	X	X
12	E		12-5	11-8-5	15	10,8	X	X
13	D	:	12-4	8-2	15,7	8		X
14	*	\$	11-8-4	11-8-3	7,9	8,2	X	X
15	C	"	12-3	8-7	15,5	8		X
16	R	¢	11-9	12-8-2	13,11	12,8		X
17	F	:	12-6	11-8-6	15	10,8	X	X
18	<	.	12-8-4	12-8-3	9,7	8,2	X	X
19	V	=	0-5	6-8	1	8,6	X	
20	T	0-8-2	0-3	0-8-2	14,5	14,8		X
21	G	-	12-7	11-8-7	15	10,8	X	X
22	MASTERCARD						X	X
23	B	!	12-2	11-8-2	15	10,8	X	X
24	Y	!	0-8	12-8-7	1,9	12,8		X
25	H	'	12-8	8-5	15,9	8,4		
26	DUP							
27	N	(11-5	12-8-5	13	12,8	X	X
28	U	1	0-4	1	1,7			X
29	J	4	11-1	4	13,3			X
30	-	-	11	11	13	10		
31	M	7	11-4	7	13,7			X
32	I	2	12-9	2	15,11			X
33	K	5	11-2	5	13	4	X	
34	/	0	0-1	0	14,3	14		
35	,	8	0-8-3	8	19,5	8		
36	O	3	11-6	3	13	2	X	
37	L	6	11-3	6	13,5	6		
38	SPACE						X	X
39	.	9	12-8-3	9	15,9,5		X	X
40	P	8	11-7	12	13	12	X	
41	SKIP						X	X
42	RELEASE						X	X
43	AUX DUP						X	X
44	FEED							
45	REGISTER						X	X
46	PROG 2							
47	ALPHA							
48	LEFT ZERO						X	X
49	LEFT ZERO						X	X
50	PROG 1							

ODD NUMBER BAILS ON RIGHT SIDE OF KEYBOARD
EVEN NUMBER BAILS ON LEFT SIDE OF KEYBOARD

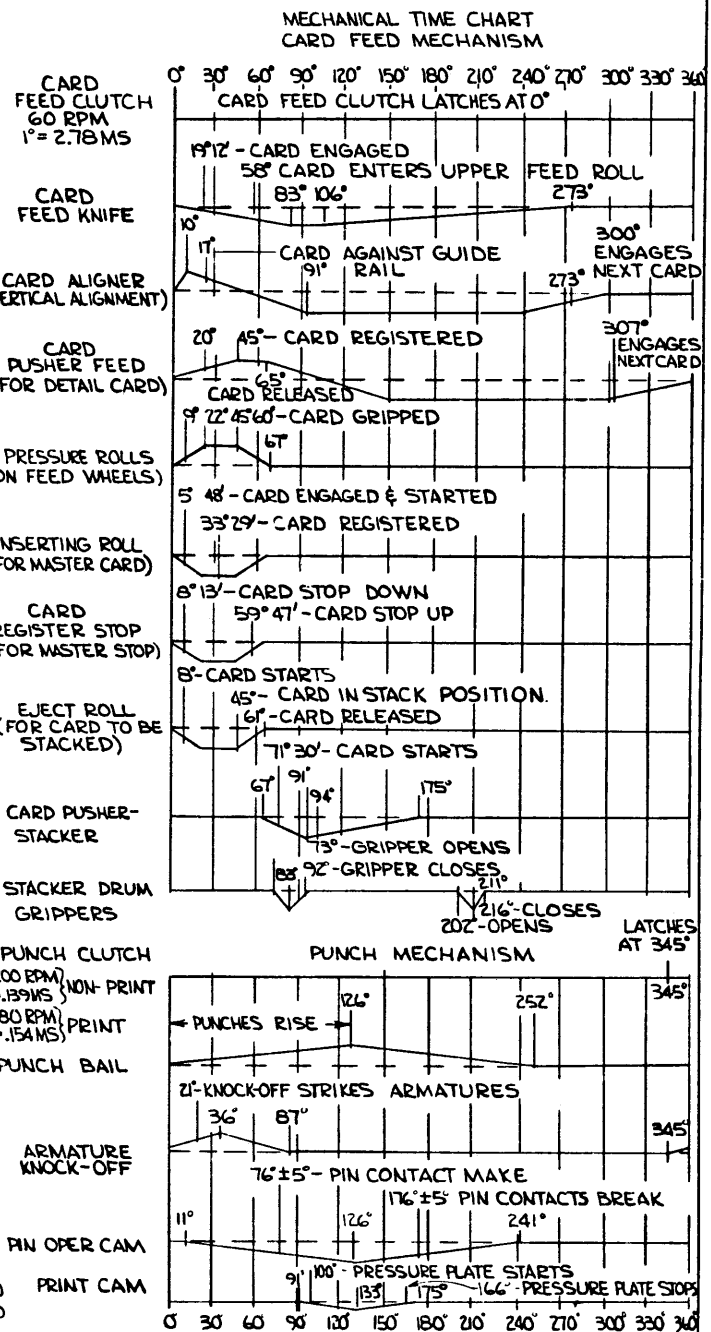

INTERNATIONAL BUSINESS MACHINES CORP.		DATE	CHANGE NO.	DATE	CHANGE NO.	NOTE	DEVELOPMENT NO.
NAME	SYSTEMS MACHINAM	12 30 64	205199			1 PRINT TO ENG. SPEC. NO. 895291	0373561
DESIGN	WT 1123(A) MODEL						
DETAIL							
CHECK	LF 1123(A) DRAW						
APPRO	RC 1123(A) CHECK						00.29.10.0

MOD "B" NUMERIC KEYBOARD - INTERPOSER MAGNETS AND PIN SENSE

W/C

5405943

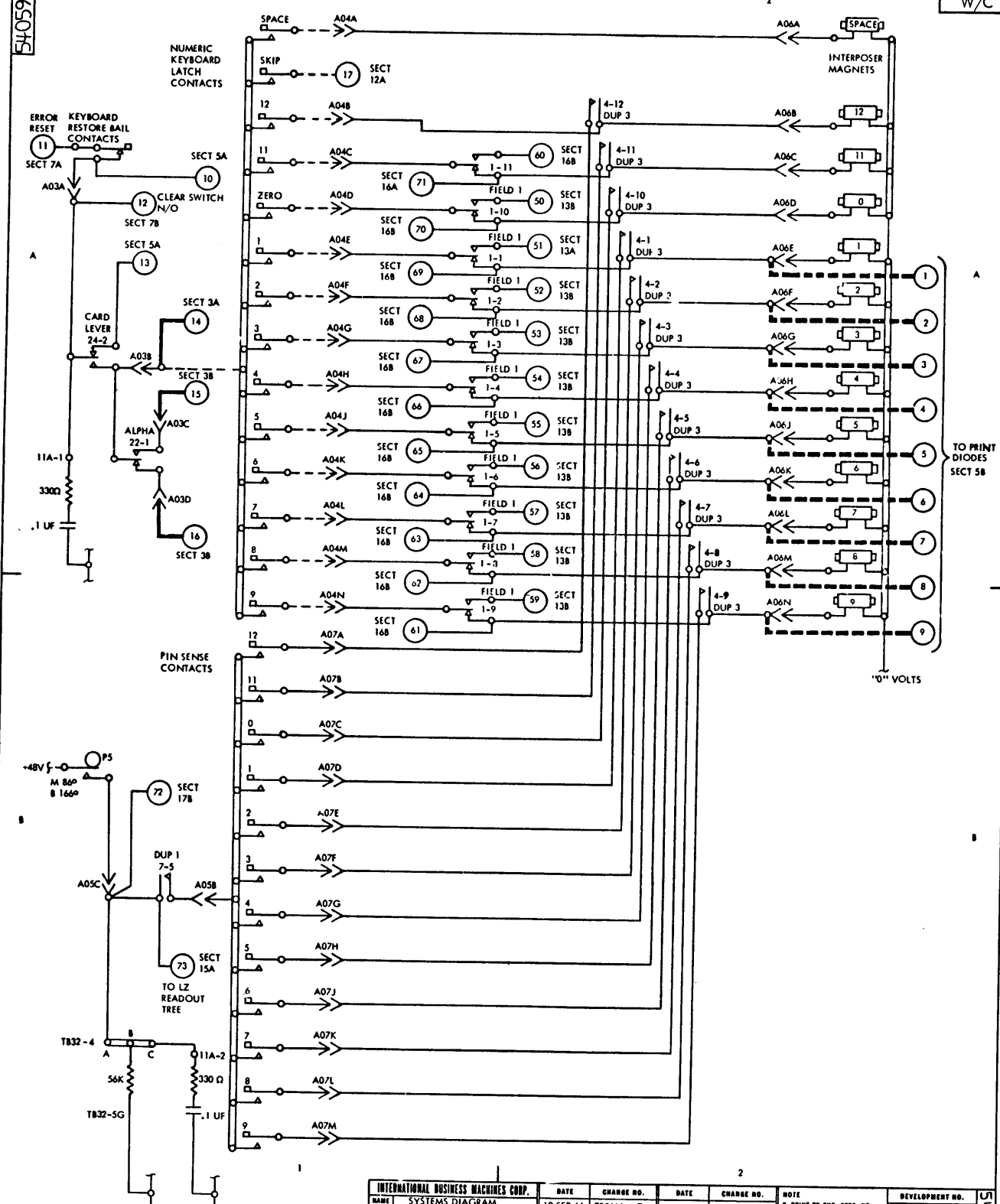

NOTES
 I POINT TO POINT WIRING FOR +48V AND "0" VOLT NETS SHOWN ON REF PAGE.

INTERNATIONAL BUSINESS MACHINES CORP.		DATE	CHANGE NO.	DATE	CHANGE NO.	NOTE	DEVELOPMENT NO.
NAME	SYSTEMS DIAGRAM	19 SEP 66	205666 - G			X PRINT TO ENG. SPEC. NO. 895291	5405943
NUM KYBD - INT MAG - PIN SENSE							
DESIGN	EB 1 SEP 66						
DETAIL	AG 9 SEP 66						
CHECK	RAS 9 SEP 66						
APPRO	RSS 9 SEP 66						

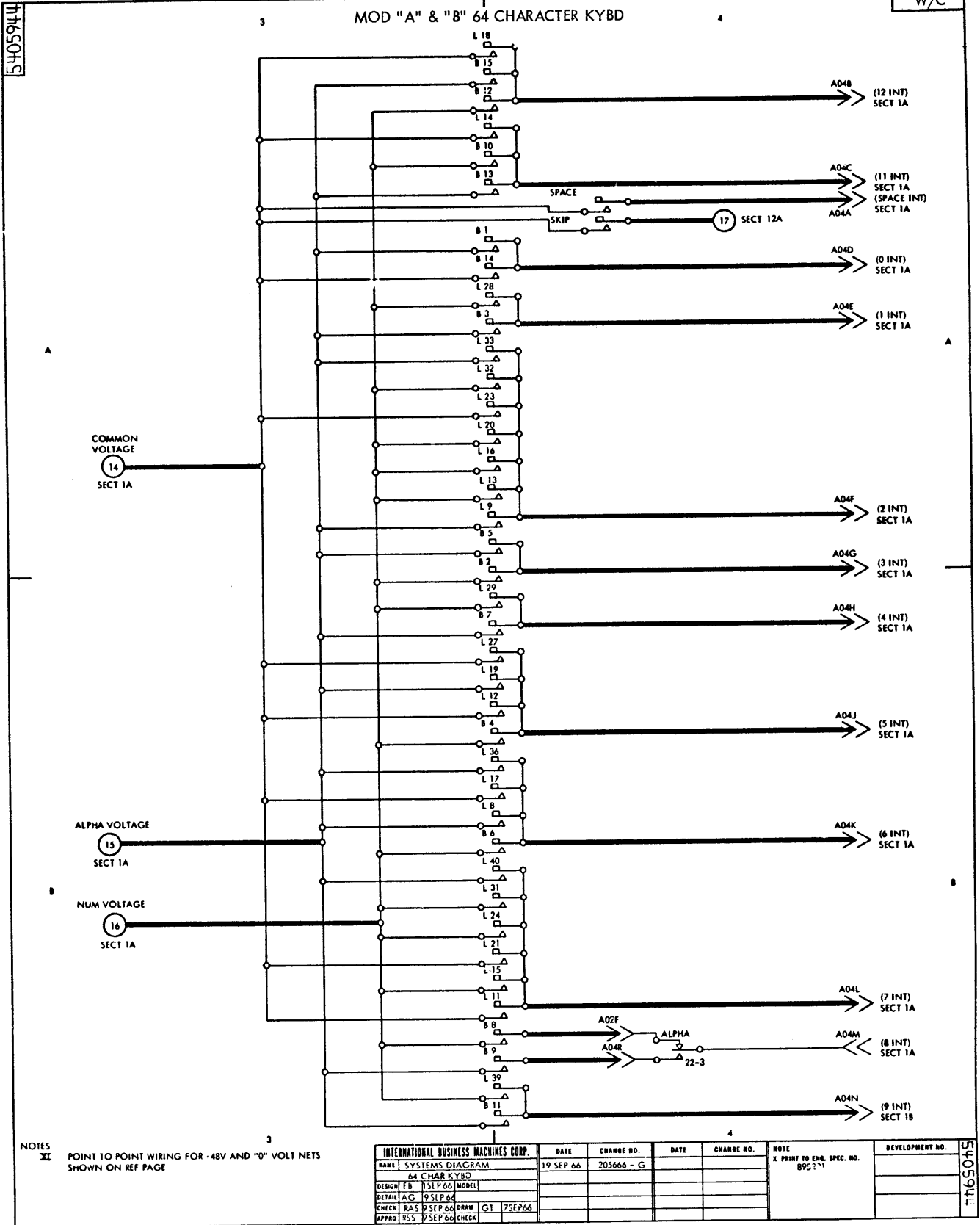

NOTES
 XI POINT TO POINT WIRING FOR +48V AND "0" VOLT NETS SHOWN ON REF PAGE

INTERNATIONAL BUSINESS MACHINES CORP.		DATE	CHANGE NO.	DATE	CHANGE NO.	NOTE	DEVELOPMENT NO.
NAME	SYSTEMS DIAGRAM	19 SEP 66	205666 - G			NOTE X PRINT TO ENL. SPEC. NO. 895-11	5405944
	64 CHAR KYBD						
DESIGN	FB 15 SEP 66 MODEL						
DETAIL	AC 19 SEP 66						
CHECK	RAS 19 SEP 66 DRAW	GT	75 SEP 66				
APPRO	USS 19 SEP 66 CHECK						

5405945

W/C

MOD "A" & "B" CARD FEED, PROG SELECT, PRINT

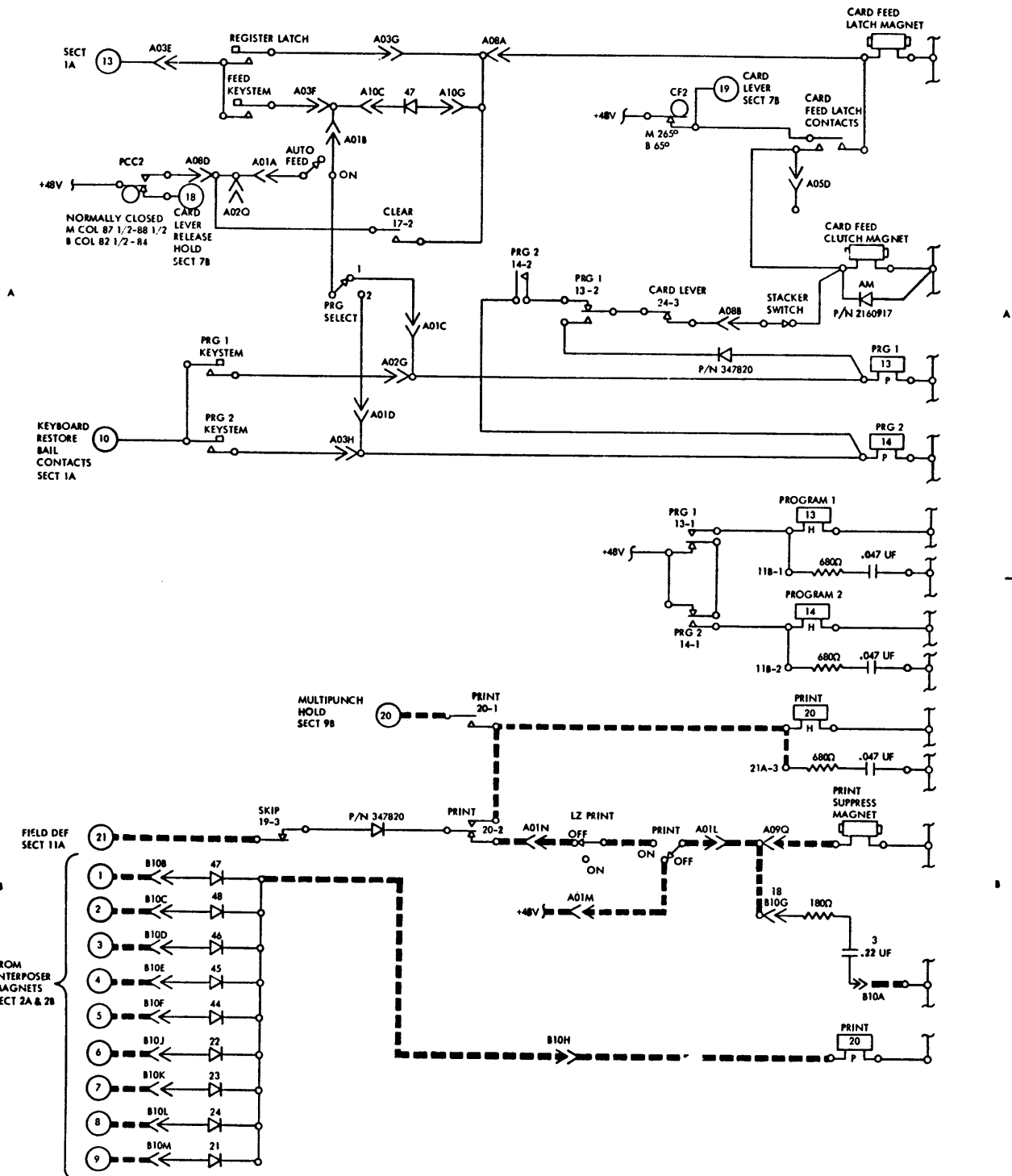

NOTES
 X POINT TO POINT WIRING FOR +48V AND "0" VOLT NETS SHOWN ON REF PAGE

INTERNATIONAL BUSINESS MACHINES CORP.		DATE	CHANGE NO.	DATE	CHANGE NO.	NOTE	DEVELOPMENT NO.
NAME	SYSTEMS DIAGRAM	19 SEP 66	205666-G			X PRINT TO ENCL. SPEC. NO.	
CD	FEED-PROG SEL-PRINT						
DESIGN	E 8 SEP 66						
DETAIL	AG 9 SEP 66						
CHECK	RAS 9 SEP 66						
APPRO	RS 9 SEP 66						
						895291	

5405945

5405916

W/C

MOD "B" DUP, CLEAR, RELEASE, CARD LEVER

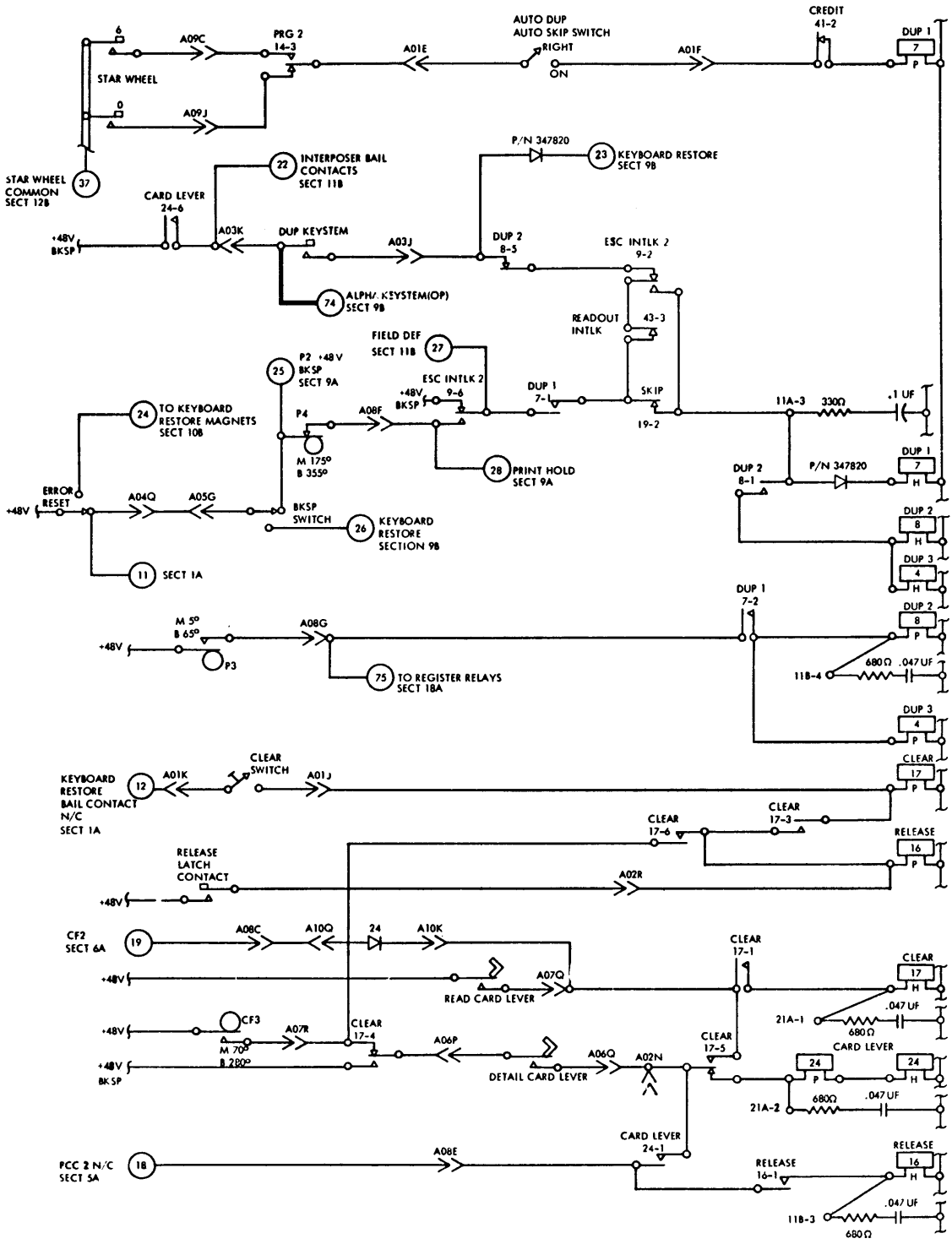

NOTES
 1. POINT TO POINT WIRING FOR +48V AND +0V VOLT NETS SHOWN ON REF PAGE

INTERNATIONAL BUSINESS MACHINES CORP.		DATE	CHANGE NO.	DATE	CHANGE NO.	NOTE	DEVELOPMENT NO.
NAME	SYSTEMS DIAGRAM	19 SEP 66	205666 - G			NOTE X PRINT TO ENG. SPEC. NO. 895291	5405916
DUP - CLEAR - REL - CD LEVER							
DESIGN	EB SEP 66						
DETAIL	AG SEP 66						
CHECK	RAS SEP 66						
APPROV	KSS SEP 66						

MOD "B" PUNCH CLUTCH, MULTI PCH, ALPHA, KEYBOARD RESTORE

W/C

5405947

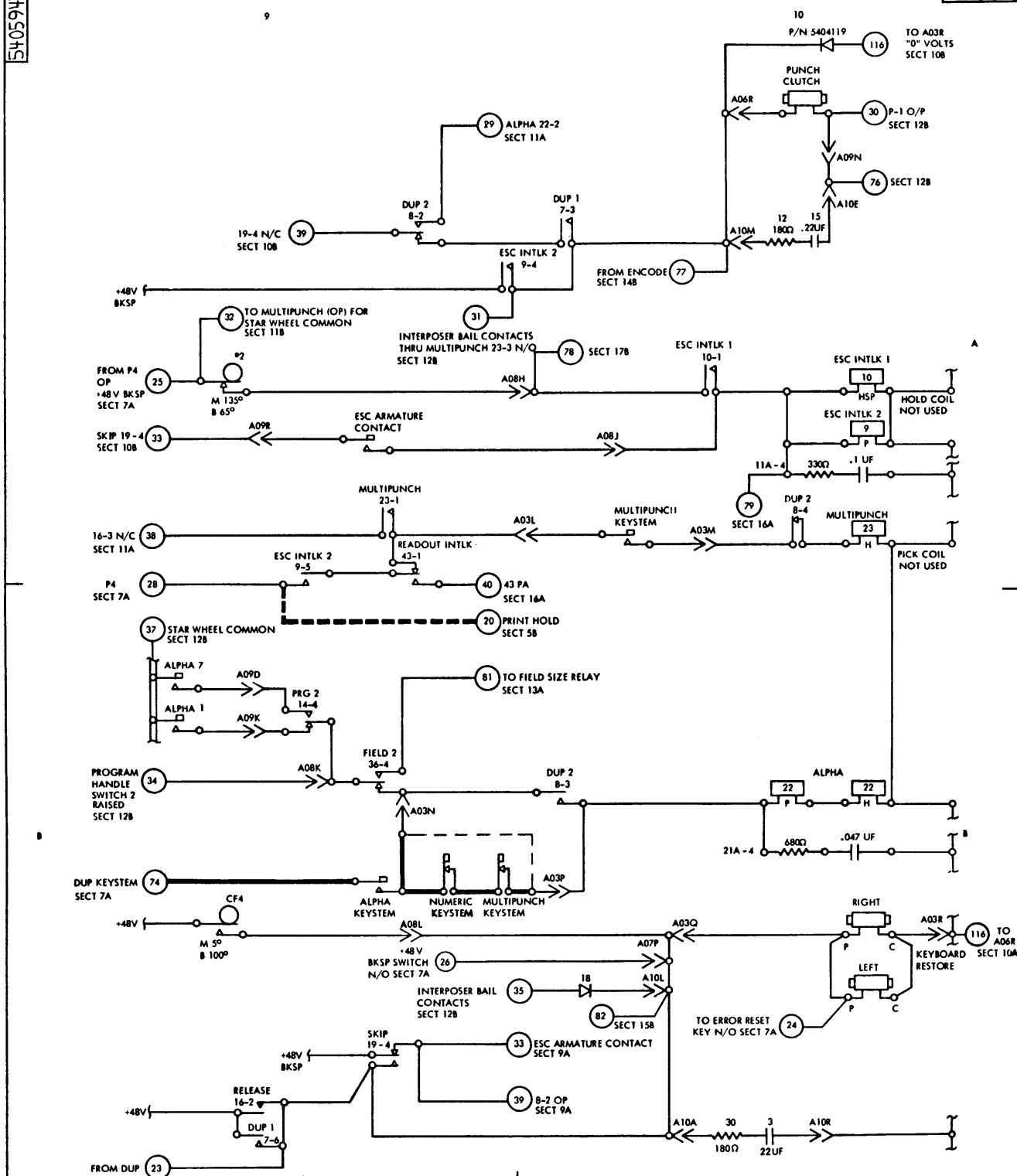

NOTES
 XI POINT TO POINT WIRING FOR +48V AND "0" VOLT NETS SHOWN ON REF PAGE

INTERNATIONAL BUSINESS MACHINES CORP.		DATE	CHANGE NO.	DATE	CHANGE NO.	NOTE	DEVELOPMENT NO.
NAME	SYSTEMS DIAGRAM	19 SEP 66	205666-G			NOTE X PRINT TO ENG. SPEC. NO. 895291	
PC	PUNCH CLUTCH-MP-ALPHA-KYBD RES						
DENGIN	EB 1 SEP 66						
DETAIL	AG 10 SEP 66						
CHECK	RAS 15 SEP 66						
APPRO	RSS 15 SEP 66						

7405948

MOD "A" & "B" SKIP - ESCAPE MAGNET

W/C

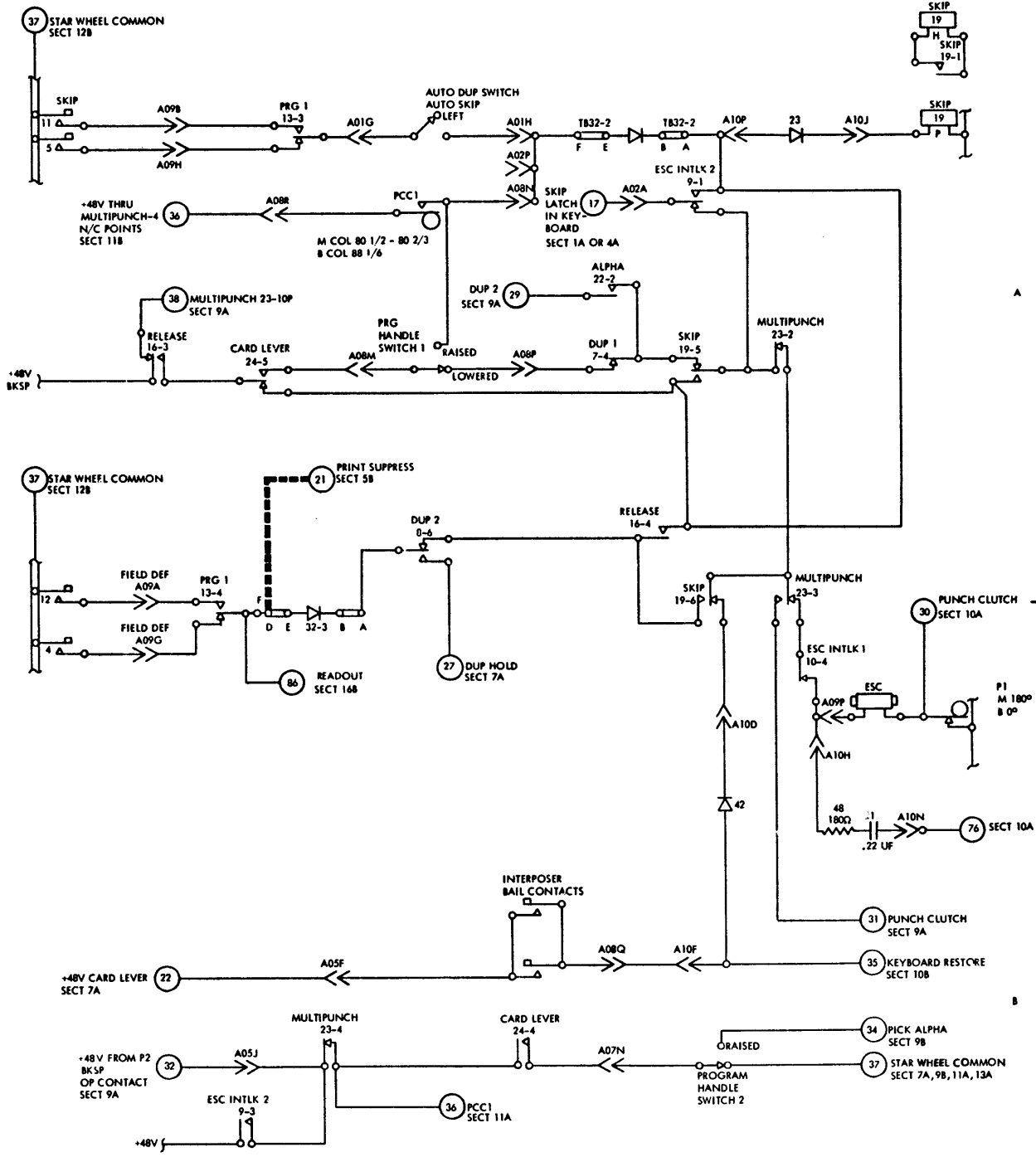

NOTES
 XI POINT TO POINT WIRING FOR +48V AND "0" VOLT NETS SHOWN ON REF PAGE

INTERNATIONAL BUSINESS MACHINES CORP.		DATE	CHANGE NO.	DATE	CHANGE NO.	NOTE	DEVELOPMENT NO.
SYSTEMS DIAGRAM		19 SEP 66	205666 - G			NOTE X PRINT TO ENR. SPEC. NO. 895291	
SKIP - ESCAPE - MAGNET							
DESIGN	E B	11 SEP 66	MODEL				
DETAIL	A G	19 SEP 66					
CHECK	R A S	19 SEP 66	DRAW	G T	7 SEP 66		
APPRO	R S S	19 SEP 66	CHECK				

7405948

5105919

MOD "B" FIELD SIZE - ENCODE

W/C

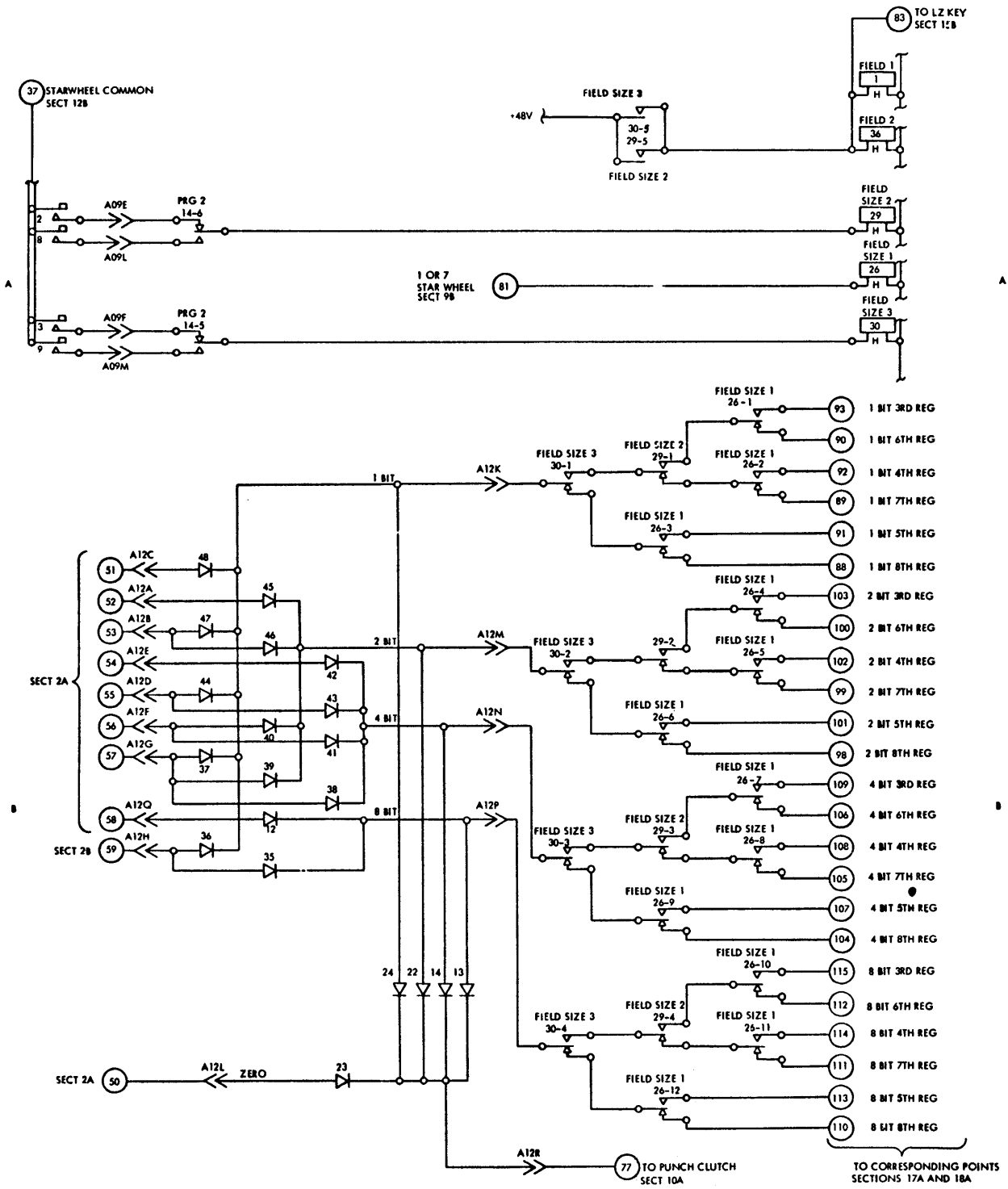

NOTES
 II POINT TO POINT WIRING FOR +48V AND "0" VOLT NETS SHOWN ON REF PAGE

INTERNATIONAL BUSINESS MACHINES CORP.		DATE	CHANGE NO.	DATE	CHANGE NO.	NOTE	DEVELOPMENT NO.
NAME	SYSTEMS DIAGRAM	19 SEP 66	205666 - G			NOTE X POINT TO ENCL. SPEC. NO. 895291	
	FIELD SIZE - ENCODE						
DESIGN	Ed 8 SEP 66 MODEL						
DETAIL	AG 9 SEP 66						
CHECK	RAS 9 SEP 66 DRAW GT 7 SEP 66						
APPROV	RSS 9 SEP 66 CHECK						

5409950

MOD "B" 1A REGISTER DECODE-READOUT

16
1ST REGISTER

W/C

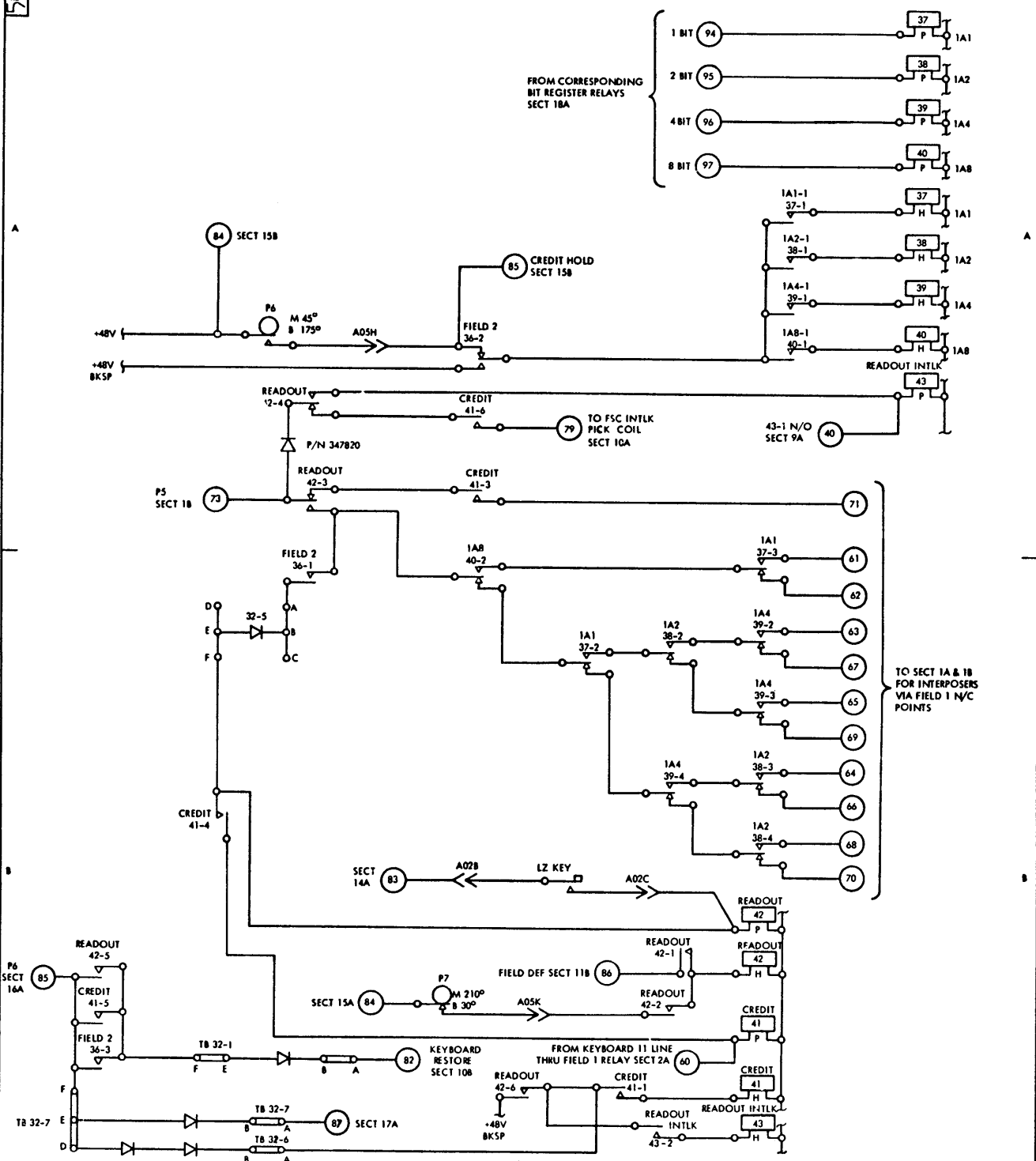

NOTES
 I POINT TO POINT WIRING FOR +48V AND "0" VOLT NETS SHOWN ON REF PAGE

INTERNATIONAL BUSINESS MACHINES CORP.		DATE	CHANGE NO.	DATE	CHANGE NO.	NOTE	DEVELOPMENT NO.
SYSTEMS DIAGRAM		19 SEP 66	205666 - G			NOTE X PRINT TO ENL. SPEC. NO. 895291	5409950
1A REG DECODE - READOUT							
DESIGN	ED	11 SEP 66	MODEL				
DETAIL	AG	19 SEP 66					
CHECK	RAS	19 SEP 66	DRAW	GT	7 SEP 66		
APPROV	RSS	19 SEP 66	CHECK				

5405951

MOD "B" BIT REGISTER

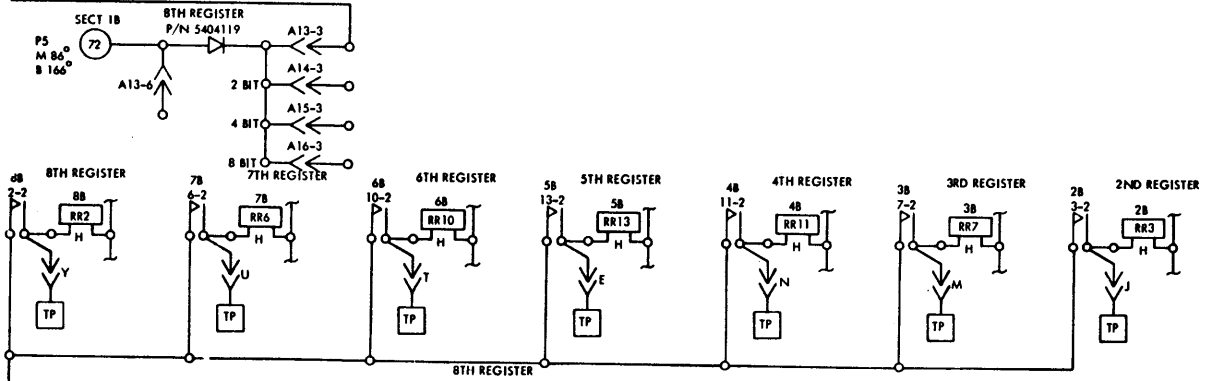
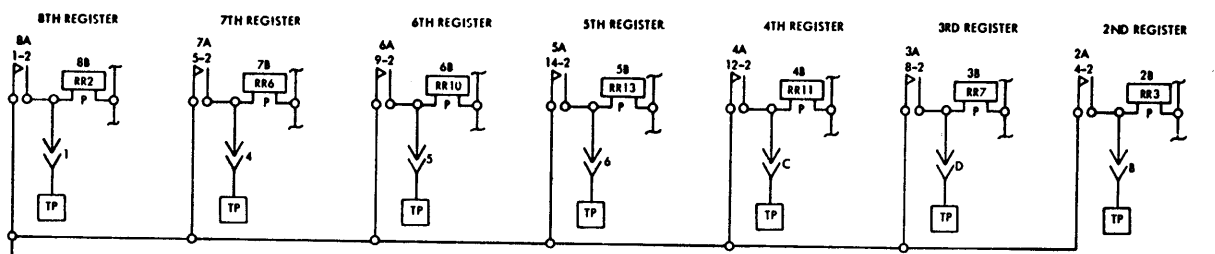
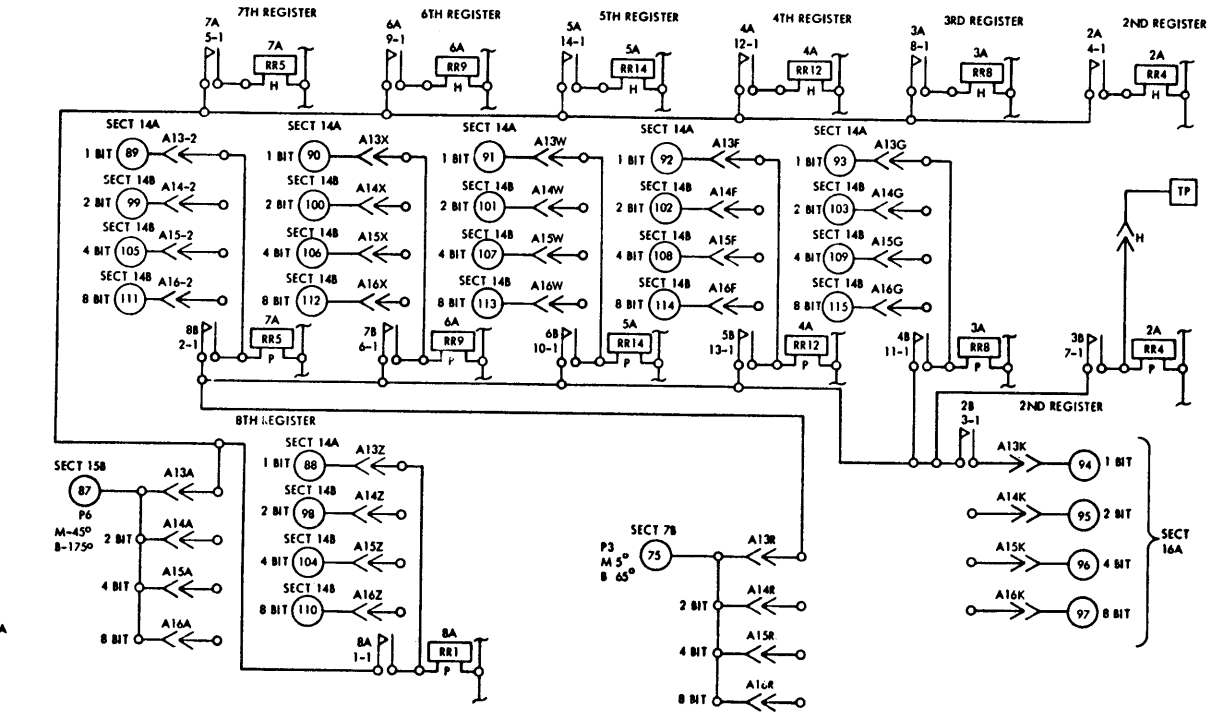

NOTES
 XI ONLY REED RELAY CARD FOR 1 BIT POSITION IS SHOWN. CARDS ARE IDENTICAL FOR 1 BIT, 2 BIT, 4 BIT AND 8 BIT.
 XII POINT TO POINT WIRING FOR -48V AND "0" VOLT NETS SHOWN ON REF PAGE

INTERNATIONAL BUSINESS MACHINES CORP.		DATE	CHANGE NO.	DATE	CHANGE NO.	NOTE	DEVELOPMENT NO.
R-WE	SYSTEMS DIAGRAM	19 SEP 66	205666-G			X PRINT TO ENG. SPEC. NO. 895291	
	BIT REGISTER						
DESIGN	EB	15 SEP 66					
DRAWN	AG	19 SEP 66					
CHECK	BAK	19 SEP 66					
APPROV	BSS	19 SEP 66					

5405952

PUNCH UNIT TERM BLOCK FACING WRINKLED LUGS

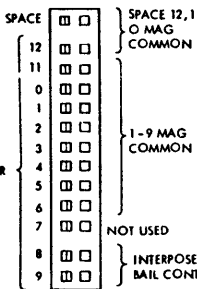

DISCRETE COMPONENTS

PART NO.	FROM	TO	SECT.
2160917	ACROSS CD FD MAG	6A	
347820	19-3 N/C	20-2 OP	5B
347820	7-6 N/O	8-5 N/C	8A
347820	7 HA	8-1 OP	8A
347820	42-4 OP	42-3 OP	15A
5404119	A03R	A06R	10A
5404119	A133	A136	17B

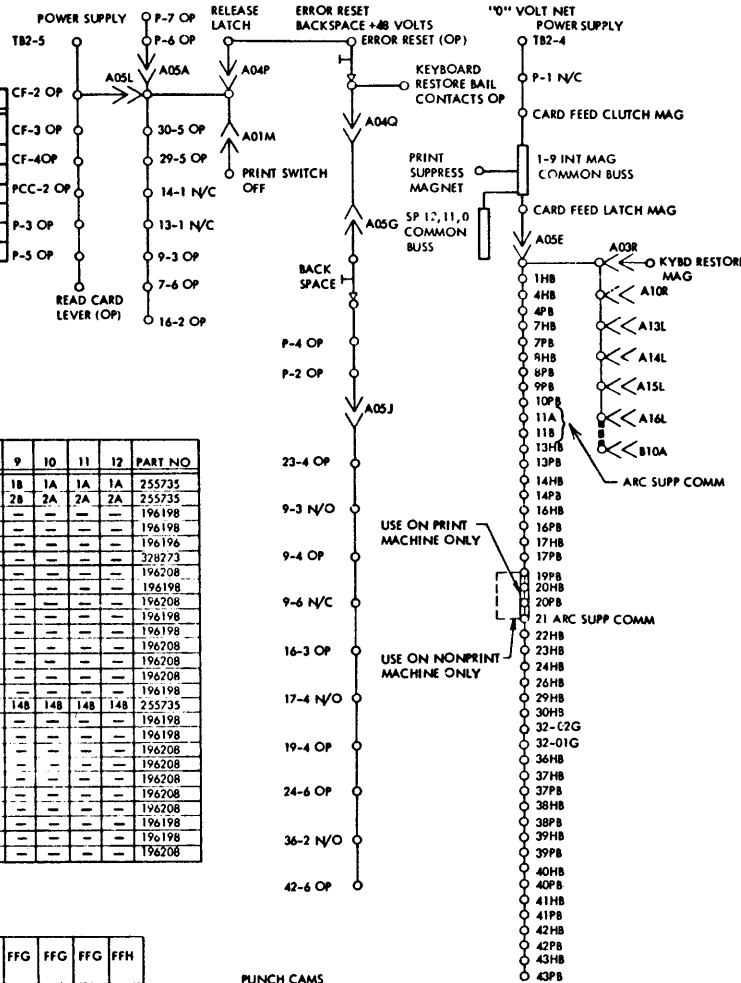

WIRE CONTACT RELAY LOCATION

RELAY	NO	COIL	1	2	3	4	5	6	7	8	9	10	11	12	PART NO
FIELD 1	1	14A	1A	1A	1A	1A	1A	1A	1A	1A	1A	1A	1A	1A	255735
DUP 3	4	8B	8A	2A	2A	2A	2A	2A	2A	2A	2A	2A	2A	2A	255735
DUP 1	7	8A	8A	8A	7A	10A	12A	1B	9B						196198
DUP 2	8	8B	8A	8A	9A	10B	10A	7A	11A						196198
ESC INLK 2	9	10A		12A	8A	11B	9A	9A	7A						196196
ESC INLK 1	10	10A		10A											328273
PROGRAM 1	13	6A	6A	6A	6A	11A	11B								196208
PROGRAM 2	14	6A	6B	6B	6A	7A	9B	13A	13A						196198
RELEASE	16	8B	8B	8B	9B	11A	12A								196208
CLEAR	17	3B	8B	8B	8A	5B	8B	8B	8B						196198
SKIP	19	12A	12A	12A	8A	5B	9B	12A	12A						196198
PRINT	20	6B	6B	5B	5B										196208
ALPHA	22	10B	10B	1A	12A	4B	XSKIP								196208
MULTIPUNCH	23		10A	9A	12A	12A	11B								196208
CARD LEVER	24	8B	8B	8B	1A	6A	11B	11A	7A						196198
FIELD SIZE 1	26	8B	14A	14A	14A	14A	14B	14B	14B	14B	14B	14B	14B	14B	255735
FIELD SIZE 2	29	8B	14A	14A	14B	14B	14B	14B	14A						196198
FIELD SIZE 3	30		14A	14A	14B	14B	14B	14A							196198
FIELD 2	36		14A	15B	15A	15B	9B								196208
IA1 REG	37	16A	16A	16A	16B	16B									196208
IA2 REG	38	16A	16A	16A	16B	16B									196208
IA4 REG	39	16A	16A	16A	16B	16B									196208
IA8 REG	40	16A	16A	16A	15B										196208
CREDIT	41	16B	16B	16B	8A	15A	15B	15A							196198
READOUT	42	16B	16B	16B	16B	15A	15B	15B							196198
READOUT INLK	43	16A	16B	9A	16B	8A									196208

CONNECTOR CHART

SMS CARD CODE	A01	A02	A03	A04	A05	A06	A07	A08	A09	A10	A11	A12	A13	A14	A15	A16	B10
A	5A	12A	1A	1A	20A	2A	1B	6A	11A	10B		13B	17A	17A	17A	17A	6B
B	5A	15B	1A	1A	1B	2A	1B	6A	11A			13B					5B
C	5A	16B	1A	1A	1B	2A	1B	7B	7A	5A		13B					5B
D	5A	MCT	1A	1A	6A	2A	1B	5A	9B	12B		13B					5B
E	7A	AUX DUP	5A	1A	20A	2A	1B	7B	13A	10A		13B					5B
F	8A	4B	5A	1A	11B	2A	1B	7A	13A	12B		13B	18A	18A	18A	18A	5B
G	11A	5A	5A	1A	7A	2A	1B	7B	11B	5A		13B	18A	18A	18A	18A	6B
H	11A	5A	1A	15A	2A	1B	9A	11A	12B			13B					6B
J	7B	7A	1A	11B	2A	1B	10A	7A	12A								5B
K	7B	7A	1A	16B	2A	1B	9B	7B			14A	16A	16A	16A	16A	16A	5B
L	6B	10A	1A	20A	2A	1B	9B	13A	10B		13B	20A	20A	20A	20A	20A	5B
M	6B	XSKIP	10A	1A	VLCD	2A	1B	11A	13A	10A		13B					5B
N	6B	8B	9B	1B	H55	2B	12B	11A	10A	12B		13B					5B
P	MCT	11A	10B	20A	H55	7B	10B	11A	12B	12A		13B					5B
Q		5A	10B	7A	MCT	8B	8B	12B	6B	7B		13B					5B
R		8B	10B	4B	H55	10A	7B	1A	9A	10B		14B	18A	18A	18A	18A	5B
S																	
T																	
U																	
V													17B	17B	17B	17B	
W													17A	17A	17A	17A	
X													17A	17A	17A	17A	
Y																	
Z																	
1																	
2																	
3																	
4																	
5																	
6																	
7																	
8																	

PUNCH CAMS

NO	LOC	PART NO	M	B
1	12B	309630	180° ± 1	0° ± 3
2	9A	309634	135° ± 3	65° ± 2
3	7B	350359	5° ± 1	65° ± 3
4	7A	309630	175° ± 3	355° ± 2
5	1B	309629	86° ± 3	166° ± 2
6	15A	376429	45° ± 2	175° ± 3
7	15B	309630	210° ± 3	30° ± 2

ARC SUPPRESSION BLOCKS

PIN	11A	11B	21A
1	1A	6A	8B
2	1B	6B	8B
3	8A	8B	6B
4	10A	8B	10B

CARD FEED CAMS

NO	LOCATION	PART NO	MAKE CONTACT	BREAK CONTACT
2	6A	344184	265° ± 5	65° ± 2
3	7B	315042	70° ± 2	280° ± 5
4	9B	313807	5° ± 2	100° ± 5

REED RELAY DATA

PART NO.	COIL	RESISTANCE	1	2
766072	P	5735	N/O	N/O
766087	P	4500	N/O	N/O
	H	5700		

TERMINAL BLOCK #32

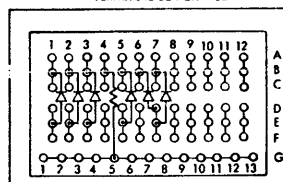

LEGEND

- PRINT FEATURE WIRING
- COMBINATION KEYBOARD WIRING
- NUMERIC KEYBOARD WIRING
- COMMON BUSS

INTERNATIONAL BUSINESS MACHINES CORP.

DATE	CHANGE NO.	DATE	CHANGE NO.
19 SEP 66	205666 - G		

NOTE: 1. PRINT TO ENG. SPEC. NO. 895291

COMPONENT SIDE

DATE	CHANGE NO.	DATE	CHANGE NO.
19 SEP 66	205666 - G		

5405952

5405942

W/C

MOD "B" LEFT - ZERO REGISTER
(SMS CARD)

COIL TERMINAL IDENTIFICATION

- 1 PICK A
- 2 HOLD A
- 3 PICK B
- 4 HOLD B

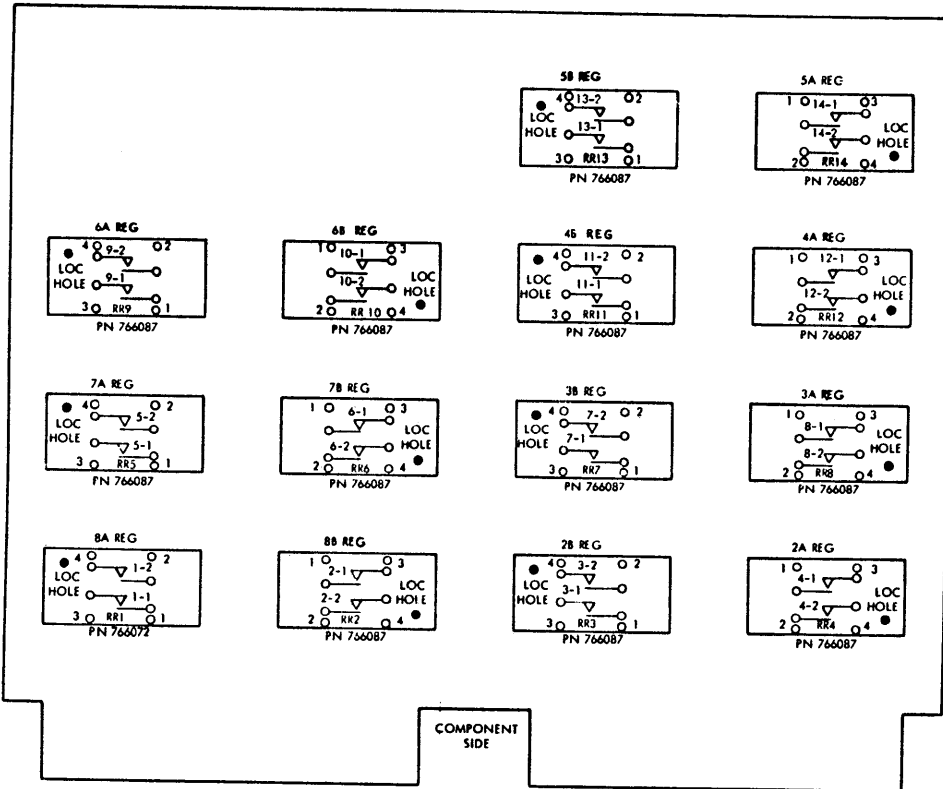

INTERNATIONAL BUSINESS MACHINES CORP.		DATE	CHANGE NO.	DATE	CHANGE NO.	NOTE	DEVELOPMENT NO.
NAME	SYSTEMS DIAGRAM	19 SEP 66	205644-G			X PRINT TO ENG. SPEC. NO. 895291	
	LZ REG (SMS CARD)						
DESIGN	EB 11 SEP 66 MODEL						
DETAIL	AC 15 SEP 66						
CHECK	RAS 19 SEP 66 DRAW GT 25 SEP 66						
APPRO	RSS 19 SEP 66 CHECK						

5405942

MOD "B" NUMERIC KEYBOARD-INTERPOSER MAGNETS AND PIN SENSE
CAPACITOR A REGISTERS

W/C

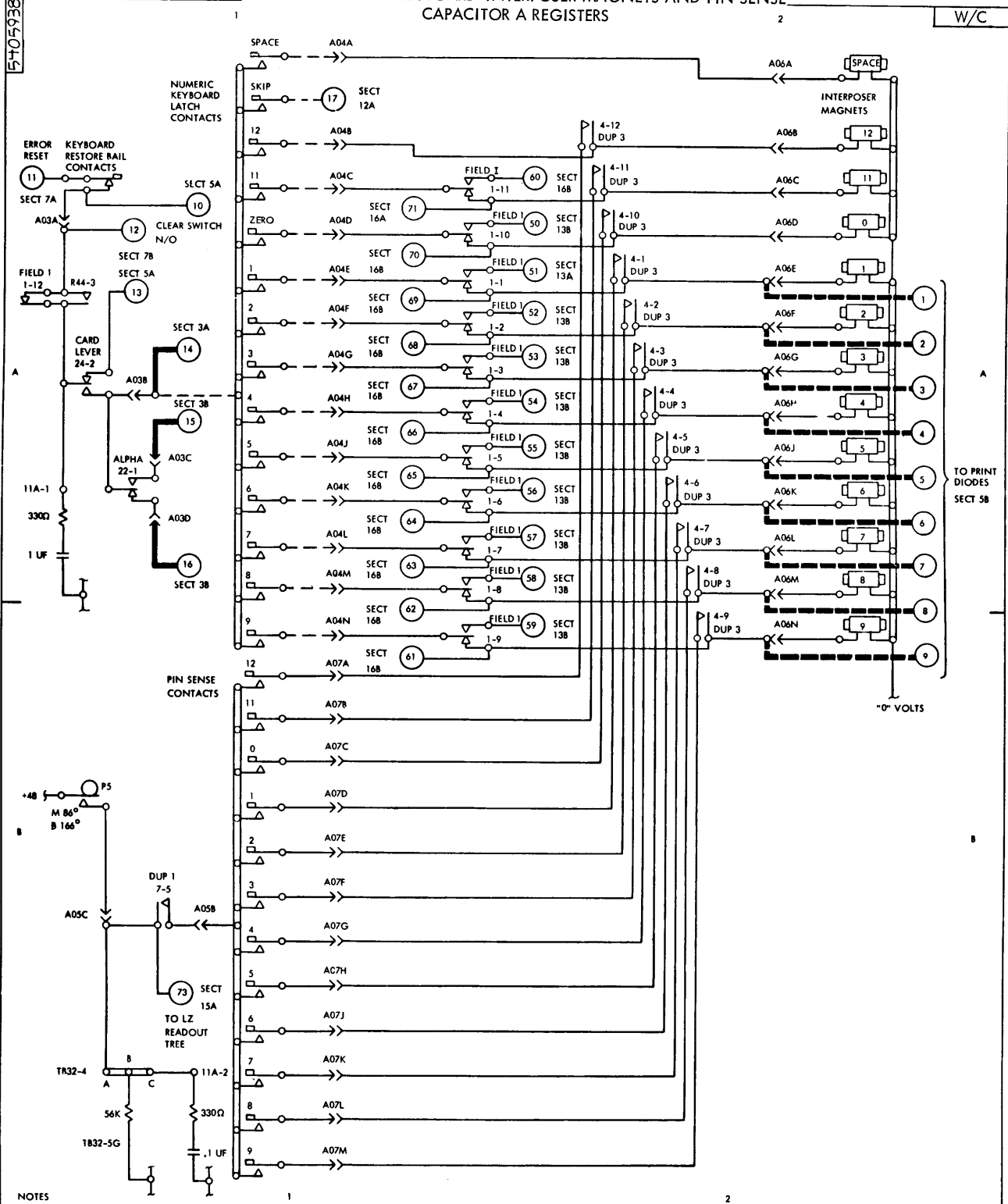

NOTES
 X PRINT TO ENG SPEC B95291
 X POINT TO POINT WIRING FOR +48V AND 0" VOLT NETS SHOWN ON REF PAGE

INTERNATIONAL BUSINESS MACHINES CORP.				DATE	CHANGE NO.	APPROVAL	DATE	CHANGE NO.	APPROVAL	DEVELOPMENT NO.
NAME SYSTEMS DIAGRAM				18SEP68	206331-C					5405938
NUM KYBD-INT MAG-PIN SENSE										
DESIGN	LB	11SEP66	MODEL							
DETAIL	AG	9SEP66	SCALE							
CHECK	RA	9SEP66	DRAWN	IDI	DAUG68					
APPROV	RSS	9SEP66	CHECK							

5405957

MOD "B" 1A REGISTER DECODE-READOUT
CAPACITOR A REGISTERS

W/C

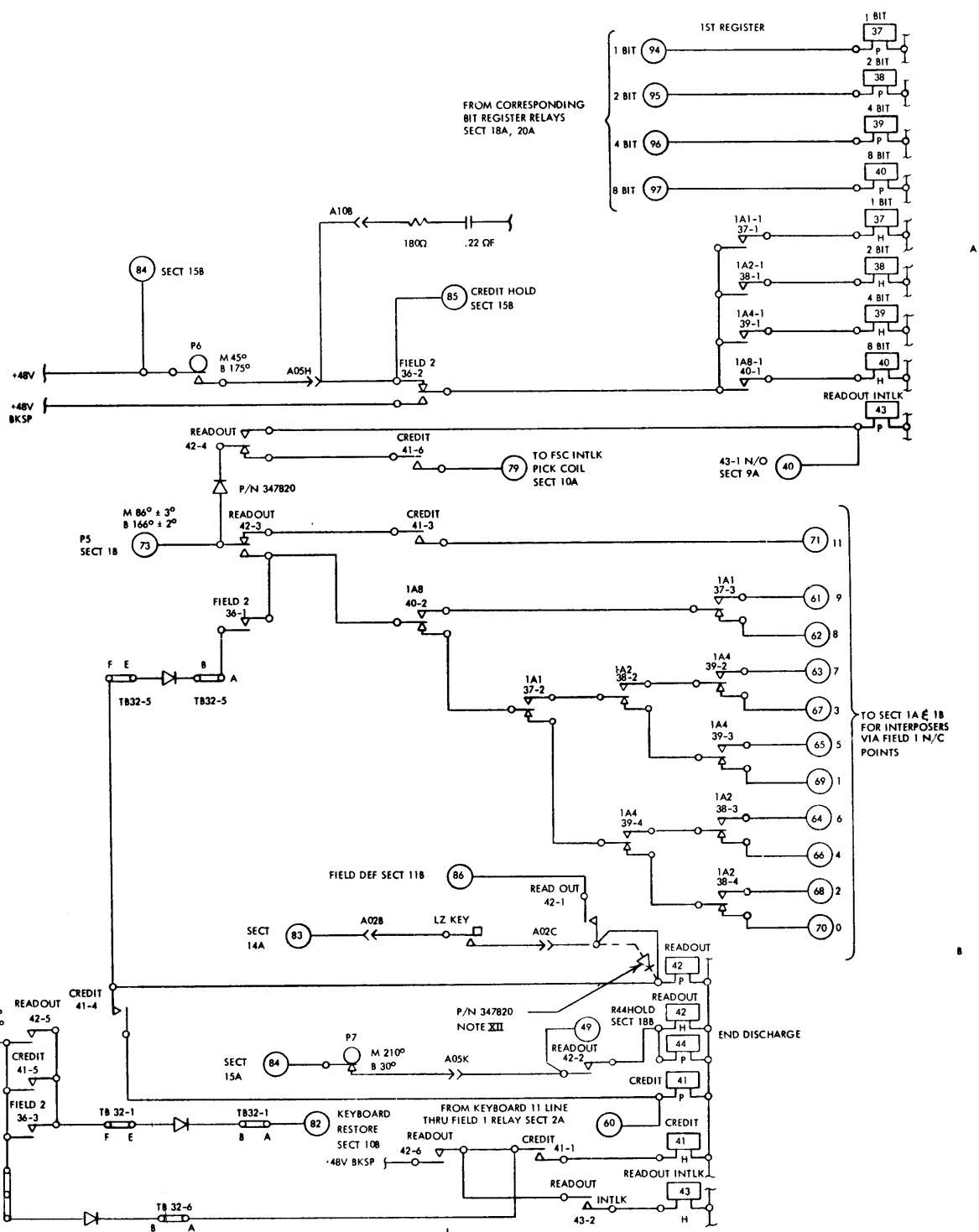

- NOTES
- I PRINT TO ENG SPEC NO 895291
 - II POINT TO POINT WIRING FOR +48V AND "0" VOLT NETS SHOWN ON REF PAGE
 - III DIODE NOT REQUIRED ON NON-PRINT. JUMPER IS INSTALLED ON NON-PRINT MACHINES

INTERNATIONAL BUSINESS MACHINES CORP.				DATE	CHANGE NO.	APPROVAL	DATE	CHANGE NO.	APPROVAL	DEVELOPMENT NO.
NAME SYSTEMS DIAGRAM				18SEP68	206331-C					5405957
1A REG DECODE - READOUT										
DESIGN	EB	11SEP66	MODP							
DETAIL	AG	05SEP66	SEC.							
CHECK	RAS	19SEP68	DR							
APPRO	RSS	19SEP68	CHGR							

MOD "B" PUNCH CLUTCH-MULTI PCH - ALPHA - KEYBOARD RESTORE
CAPACITOR A REGISTERS

5405939

W/C

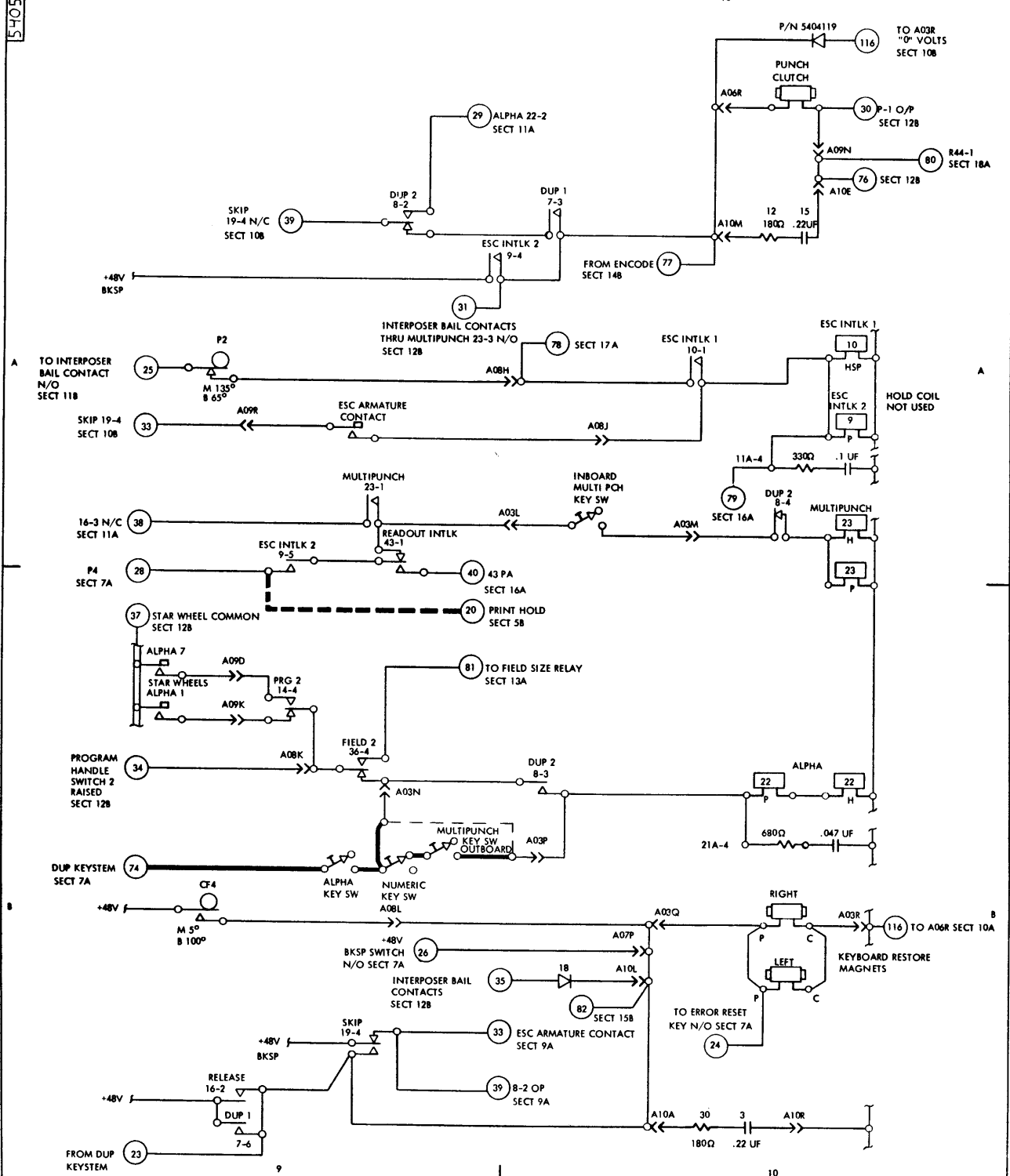

- NOTES
 X PRINT TO ENG SPEC B95291
 XI POINT TO POINT WIRING FOR +48V AND "0" VOLT NETS SHOWN ON REF PAGE

INTERNATIONAL BUSINESS MACHINES CORP.				DATE	CHANGE NO.	APPROVAL	DATE	CHANGE NO.	APPROVAL	DEVELOPMENT NO.
NAME: SYSTEMS DIAGRAM				18SEP68	206331-C					5405939
PCH CLUTCH-MP-ALPHA-KYBD RES										
DESIGN: EB 11SEP66										
DETAIL: AG 05SEP66										
CHECK: RAS 05SEP66										
APPRO: RAS 05SEP66										

MOD "B" BIT REGISTERS CAPACITOR A REGISTERS

W/C

SHEET 1 OF 3

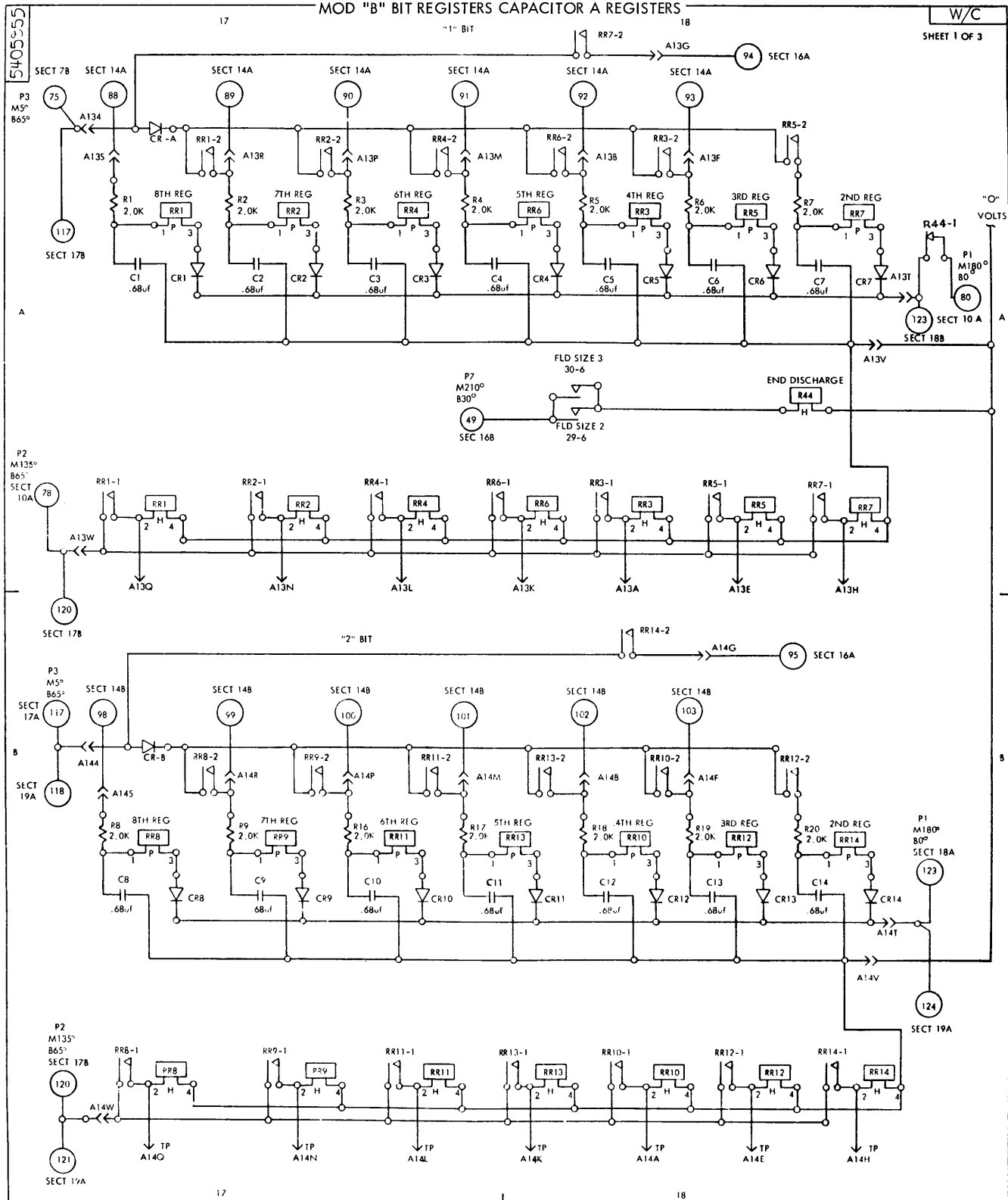

INTERNATIONAL BUSINESS MACHINES CORP.		DATE	CHANGE NO.	DATE	CHANGE NO.	NOTE	DEVELOPMENT NO.
NAME SYSTEMS DIAGRAM		1351P69	006321-C			NOTE X PRINT TO ENG. SPEC. NO. 895291	5405955
		15 JAN 69	92 0013				
DESIGN	PT	RM	CA	MODEL			
DETAIL	CD	CA	CA	CA			
CHECK	CA	CA	CA	CA			
APPRO	RM	CA	CA	CHECH			

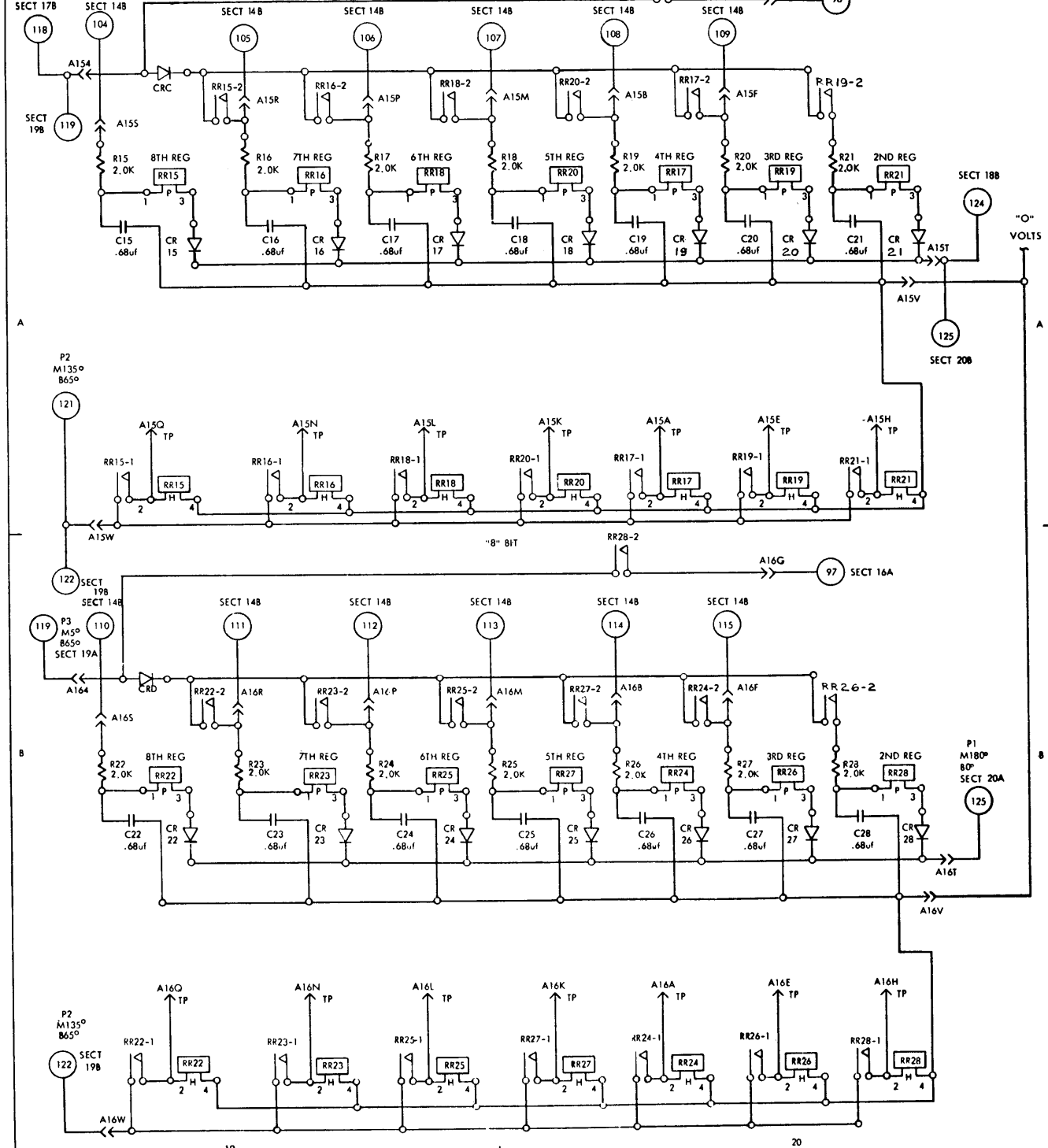

INTERNATIONAL BUSINESS MACHINES CORP.				DATE	CHANGE NO.	DATE	CHANGE NO.	NOTE	DEVELOPMENT NO.
NAME				18SEP68	206331-C			NOTE 1 PRINT TO ENG. SPEC. NO. 895291	5405955
SYSTEMS DIAGRAM				15 JAN 69	920013				
DESIGN WPT [unclear] MODEL									
DETAIL CDAL [unclear]									
CHECK RAS [unclear] DRAW [unclear]									
APPRO RMG [unclear] CHECK [unclear]									

5405956

PUNCH UNIT TERM BLOCK FACING WRINKLED LUGS

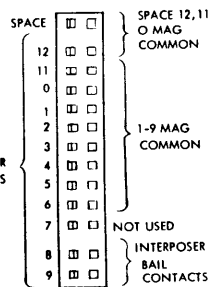
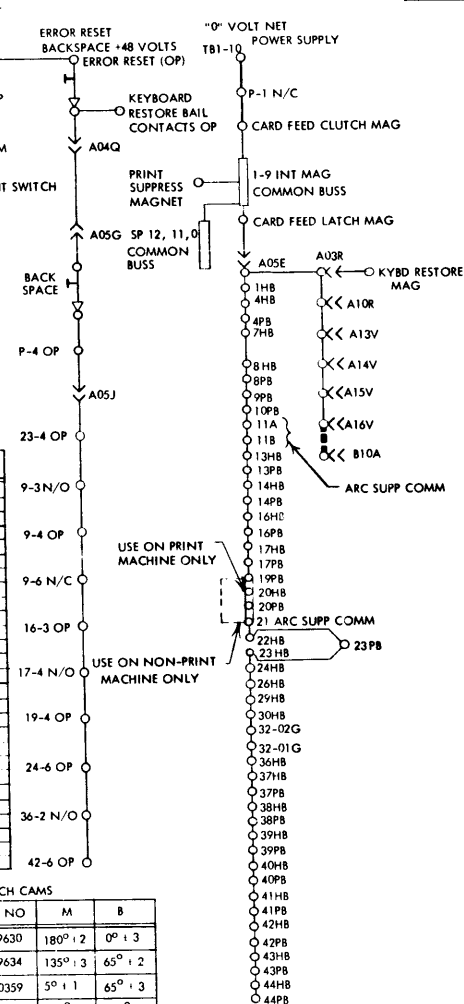
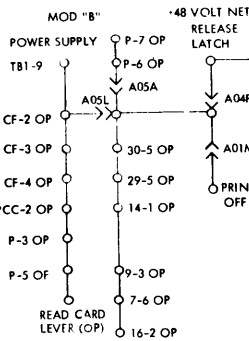

Table with columns: PART NO, FROM, TO, SECT. Rows include components like 2160917, 347820, 5404119, etc.



WIRE CONTACT RELAY LOCATION

Table with columns: RELAY, NO, COIL P, COIL H, 1, 2, 3, 4, 5, 6, 7, 8, 9, 10, 11, 12, PART NO, COIL TYPE. Rows include FIELD 1, DUP 1, ESC INLK, PROGRAM 1, CLEAR, SKIP, ALPHA, MULTIPUNCH, CARD LEVER, FIELD SIZE 1, etc.

* DO NOT INSERT WIRES

CONNECTOR CHART table with columns: SMS CARD NAME, SMS CARD CODE, PIN, A01, A02, A03, A04, A05, A06, A07, A08, A09, A10, A11, A12, A13, A14, A15, A16, B10. Rows include A, B, C, D, E, F, G, H, J, K, L, M, N, P, Q, R, S, T, U, V, W, X, Y, Z.

PUNCH CAMS table with columns: NO, LOC, PART NO, M, B. Rows include 1, 2, 3, 4, 5, 6, 7.

CARD FEED CAMS table with columns: NO, LOCATION, PART NO, MAKE CONTACT, BREAK CONTACT. Rows include 2, 3, 4.

ARC SUPPRESSION BLOCKS table with columns: PIN, 11A, 11B, 21A. Rows include 1, 2, 3, 4.

FEED RELAY DATA table with columns: PART NO, COIL, 1, 2. Row includes 766001.

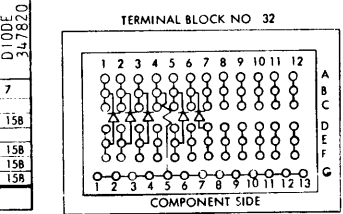

LEGEND table with columns: SYMBOL, DESCRIPTION. Rows include PRINT FEATURE WIRING, COMBINATION KEYBOARD WIRING, NUMERIC KEYBOARD WIRING.

INTERNATIONAL BUSINESS MACHINES CORP. SYSTEMS DIAGRAM table with columns: NAME, DATE, CHANGE NO, APPROVAL, DATE, CHANGE NO, APPROVAL, DEVELOPMENT NO. Includes component location table and TB32 LOCATION table.

5405955

W/C

LEFT-ZERO REGISTER
CAPACITOR A REGISTERS

SHEET 3 OF 3

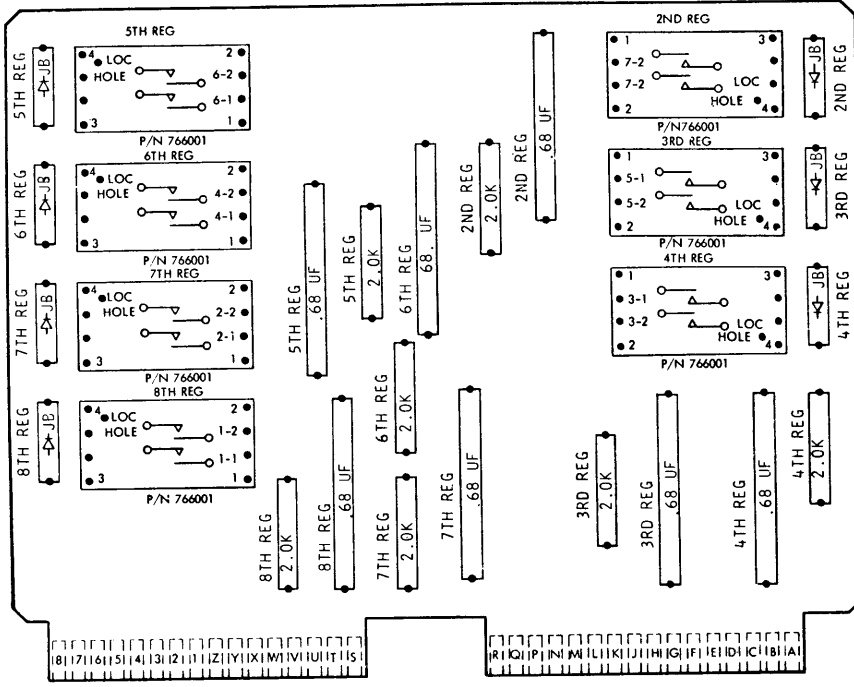

SMS TWIN CARDS
POSITIONS
A13 THRU A16

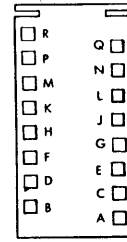
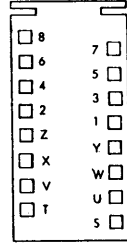

SMS SINGLE CARDS
POSITIONS A01 THRU A12 AND
B01 THRU B12

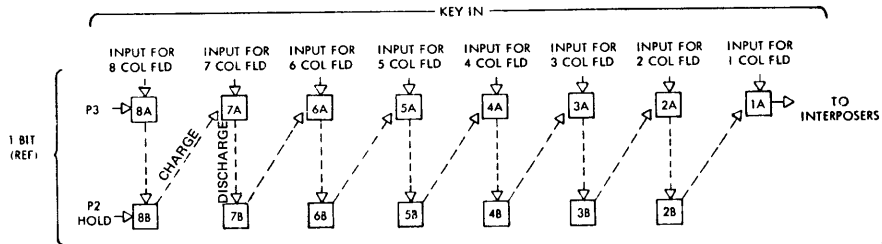
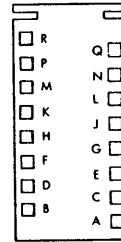

LOGIC FLOW THROUGH BIT REGISTER

VIEW - TOP OF OPEN GATE (WIRING SIDE)

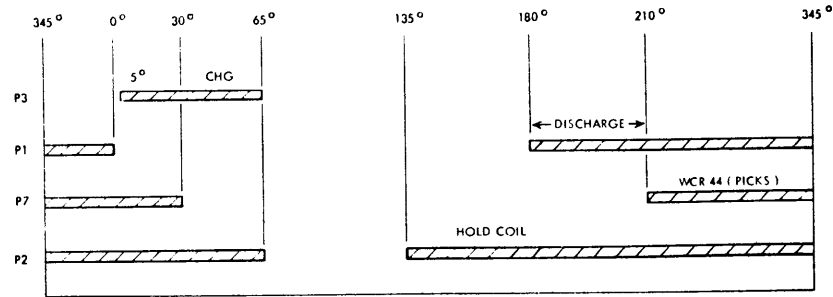

INTERNATIONAL BUSINESS MACHINES CORP.	DATE	CHANGE NO.	DATE	CHANGE NO.	NOTE	DEVELOPMENT NO.
NAME: TWIN CARD ASSEMBLY LEFT	18SEP68	206331-C			X PRINT TO ENB. OPER. NO.	
ZERO REGISTER	15JAN 69	920013			895291	
DESIGN: WPT/PDE/CLL/MODEL						
DETAIL: AG/CLL/CLL						
CHECK: RAS/PDE/CLL/DRAW						
APPRO: RMG/PDE/CLL/CHECK						
						5405955

Appendix A. Machine Characteristics

The IBM 29 Card Punch is available in nine different models shown in Figure A-1. The Model A is the basic card punch. It can have either the numeric or combination keyboard and also be equipped with or without the print feature.

The Model B is the left-zero-insertion card punch. It provides all the features of the Model A card punch with the additional left-zero feature. With the left-zero feature, it is unnecessary to key zeros to the left of significant digits in numeric fields when this feature is programmed for automatic left-zero operation.

The Model C, the interpreting card punch, provides all the features of the Model A card punch and is equipped with the print feature that can be controlled from an early read station. This makes it possible to interpret prepunched cards without punching the cards a second time.

Figure A-2 shows the compatibility of features between models.

Figure A-3 shows speeds, dimensions, and power requirements.

MODEL	NAME	KEYBOARD	FEATURE
A 11	Basic Card Punch	12-Character	
A 12	Basic Card Punch	64-Character	
A 21	Basic Card Punch	12-Character	Print
A 22	Basic Card Punch	64-Character	Print
B 11	Left-Zero Insertion Card Punch	12-Character	
B 12	Left-Zero Insertion Card Punch	64-Character	
B 21	Left-Zero Insertion Card Punch	12-Character	Print
B 22	Left-Zero Insertion Card Punch	64-Character	Print
C 22	Interpreting Card Punch	64-Character	Print

Figure A-1. IBM 29, Models

	MODEL											
	A				B				C			
Aux Duplication	X		X		X		X		X		X	
Card Insertion			X	X			X	X			X	X
Character Inhibit	X	X	X	X	X	X	X	X	X	X	X	X
High-Speed Skip	X	X			X	X			X	X		
Interspersed Gang Punch			X	X			X	X			X	X
Read Board Ext	X	X	X	X	X	X	X	X	X	X	X	X
SC Modulus 10	X	X	X	X								
SC Modulus 11							X		X			
SC Nr Generator							X		X			
Variable Length Card	X	X			X	X			X	X		

Figure A-2. IBM 29, Feature Compatibility

CHARACTERISTICS	DESCRIPTION																					
Speed:	<table border="0"> <tr> <td></td> <td><u>W/O Print</u></td> <td><u>W/Print</u></td> </tr> <tr> <td>Manual punching</td> <td>20 col/sec</td> <td>18 col/sec</td> </tr> <tr> <td>Manual duplication</td> <td>10 col/sec</td> <td>9 col/sec</td> </tr> <tr> <td>Automatic duplication</td> <td>20 col/sec</td> <td>18 col/sec</td> </tr> <tr> <td>Skipping</td> <td>80 col/sec</td> <td></td> </tr> <tr> <td>Releasing</td> <td>80 col/sec</td> <td></td> </tr> <tr> <td>Feed from pre-register to detail station</td> <td>0.250 sec</td> <td></td> </tr> </table>		<u>W/O Print</u>	<u>W/Print</u>	Manual punching	20 col/sec	18 col/sec	Manual duplication	10 col/sec	9 col/sec	Automatic duplication	20 col/sec	18 col/sec	Skipping	80 col/sec		Releasing	80 col/sec		Feed from pre-register to detail station	0.250 sec	
	<u>W/O Print</u>	<u>W/Print</u>																				
Manual punching	20 col/sec	18 col/sec																				
Manual duplication	10 col/sec	9 col/sec																				
Automatic duplication	20 col/sec	18 col/sec																				
Skipping	80 col/sec																					
Releasing	80 col/sec																					
Feed from pre-register to detail station	0.250 sec																					
Hopper	500 cards																					
Stacker	500 cards																					
Dimensions:																						
Width	39"																					
Depth	29"																					
Height	38"																					
Table height	27"																					
Maximum Weight	230 pounds																					
Power	115v, single phase, 60 cycle, 3.0a (Models A and B) 208v, single phase, 60 cycle, 1.6a (Models A and B) 230v, single phase, 60 cycle, 1.5a (Models A and B)																					
Heat Dissipation	525 BTU/Hr (Models A and B)																					
Power Receptacle Requirements	B, H (115v) C, K (208/230v)																					

Figure A-3. IBM 29, Characteristics

Appendix B. Electrical Symbols and Identification

Base Machine

For purposes of this discussion, only the reed relay diagrams are referred to in this section.

The power supply is shown on Systems 00.29.01.1 of the wiring diagram. The power supply includes the male receptacle, main line switch, long time lag fuse, start relay, $\frac{1}{2}$ horsepower motor, transformer, motor control switch, two-ampere fuses, rectifier, and filter network. All fuses on the machine are behind the chipbox. To reach the fuses, remove the chipbox.

All edge connectors are shown on the wiring diagram as arrowheads in the circuit. An example is C13 and C15 in the circuit through the multipunch (MP) keystem upper to the MP relay on Systems 01.29.04.1. This is interpreted to mean that pin 13 on tab C distributes the circuit to the MP keystem upper in the keyboard, and that the circuit returns to pin 15 on tab C to the MP relay. Refer to "Edge (SMS Card) Connectors" and "Circuit Card" for detailed information on the use of connectors. All edge connector locations are shown on Systems 01.29.18.0 of the wiring diagram.

The Z-connector is mounted to the machine frame. It connects to a paddle card that is part of the keyboard cable. The keyboard circuits are distributed through the Z- and C-edge connectors. The C-connector mounts directly to the reed relay circuit card at the rear of the machine.

NOTE: The circuit card land patterns are *not* drawn point to point. The cable wiring *is* drawn point to point. The female cable edge connector pins are shown as a wedge. The male land patterns of the circuit card tab (and the paddle card) are shown as an arrowhead. This identification enables the customer engineer to isolate either the relay circuits from the base machine or vice versa.

The symbol for a magnet is similar to that of a relay, the difference being that the magnet symbol depicts a core and the relay does not. Relays are shown as small rectangles with a digit indicating the number of the relay.

Switches are always named, and the *on* or *off* side of the switch is usually indicated. In cases where the switch has two different functions, such as 1 and 2 with the program select switch, the numbers 1 and 2 are indicated. The stacker switch is operated mechani-

cally by the cards in the stacker, and the symbol is different from those switches operated manually.

Relay points, circuit breakers, and manually operated contacts can have an operating, normally closed, or normally open contact or point. *The terms "contact" and "point" are used interchangeably.* The symbols for these three types of contacts are similar for all components.

Refer to Systems 01.29.06.1 of the wiring diagram. Dup 2 is the name of a relay contact point. Dup 2 with 120-4 over it is a normally open contact and illustrates the standard IBM symbol for a normally open contact. Each contact point has an operating contact (also known as *operating strap*) and is identified by having no point attached. The other element of the contact having a wedge-shaped point is known as the normally open point. A normally open contact, therefore, is made up of an operating contact and a normally open contact point. A normally closed contact can be recognized by a line with an extended wedge (or arrowhead) on the end. An example of a normally closed contact is the contact named dup 2 with the numerals 120-3 under it. In this case, the name alone is not the distinguishing identification of the contact point. The name dup 2 is the name of the relay, and the numbers actually identify the point.

On a wiring diagram, there is no difference in the symbol for a wire contact relay operating point and a reed relay operating point. The only difference is in the way the relay points are labeled. The wire contact relay coil is identified as WCR₁ and its points are labeled similarly.

NOTE: The 29 wiring diagram is drawn with certain conditions on the machine:

1. Power off.
2. No cards in the machine.
3. The starwheels lowered.
4. A blank card on the program drum.

There is one variation in the previous symbol explanations. The operating strap of an independently operated contact assembly (a contact assembly that is not part of a relay or circuit breaker) is designated by adding a small rectangle or square to the end of an operating contact symbol. An example of this contact can be seen on Systems 01.29.04.1 and is named MP keystem contact. Other examples of independently operated contact assemblies are the latch contacts, bail contacts, and pin contacts.

On the 29 wiring diagram, all contacts or points are shown as they are wired in the machine. A reed relay contact assembly always appears on the diagram showing the operating point and a normally closed or normally open contact in the same grouping.

The number associated with each contact point identifies it with the relay it is located on. Using the skip relay as an example, refer to Systems 01.29.17.0 and locate skip relay 123-3 and 123-6 points. The number 123 is the number of the skip relay assembly. The number-3 is a normally closed point in the skip relay. The number-6 is a normally open point in the skip relay.

During its operation, the operating contact of a relay either makes (touches) a normally open point, or it opens a normally closed point. It is common to one or the other during any operation. Therefore, the operating contact is also referred to as the *common point*.

Each starwheel contact is labeled to designate the function it performs. The number 5 and 11 starwheel contacts control (initiate) auto skip operations, the number 4 and 12 starwheel contacts control field definition, the number 6 and 0 starwheel contacts control auto dup (automatic duplication) circuits, the number 7 and 1 starwheel contacts are used for control and alpha field circuits.

The IBM symbol for a rectifier can be found in the wiring diagram. Rectifier 117CR1 is located between the detail card lever contact and the card lever relays on Systems 01.29.05.1. Electron flow in a rectifier is in the opposite direction from that of the wedge point in the rectifier symbol. The cathode of the rectifier is the vertical line in the symbol, and the anode is the base of the wedge. The positive side of the rectifier is the cathode side, and the positive terminal of each rectifier is identified with red paint so that it can be connected correctly in the circuit.

The 29 card punch uses three types of circuit breakers (CB's): the card feed CB's, the punch CB's, and the program cam contacts. CF2, CF3, and CF4 are names to identify the CB assemblies that they pertain to. Note that the symbol for CF2 (card feed number 2) has a normally closed contact. The lower contact in CF3 is the normally open contact and the contact resting against the circle is the operating contact. The circle represents the cam that moves the operating strap of the CB.

Circuit breakers close and open at different times and for different durations of time. Looking again at CF2, the title M 355° means that this CB makes contact when the card feed shaft is at 355° on the card feed index. The title B 180° means that CF2 breaks contact at 180° on the card feed index.

Punch CB3 (P3) and punch CB4 (P4) are in the dup 2 relay circuits. P3 is shown as a normally open CB. All CB's on the 29 Card Punch are the normally open type, yet you can see that P2 is shown as a normally closed CB, and P3 as a normally open CB. This is because the CB's are shown on the diagram with the punch clutch latched. The punch shaft restores to its home position or "latches" at 345°. Therefore, at 345°, P4 is making contact and is shown normally closed.

P3 is not making contact and is shown as normally open. For this reason, P1, which makes at 180° and breaks at 0°, is shown as a normally closed CB.

The symbol for CF3 indicates that this is card feed CB number 3 and that it makes at 70° and breaks at 150° on the card feed index. The card feed camshaft, on which the CF cams are mounted, latches at 0°. Since neither CF3 nor CF4 are made at 0°, both of these are shown as normally open CB's.

PCC2 (program cam contact number 2) is shown on Systems 01.29.04.1. PCC1 (program cam contact number 1) is shown with a normally open point and an operating point. PCC2 has three points: an operating point, a normally open point, and a normally closed point. The make and break time of the program cam contacts is given in columns. The timing of these contacts is controlled by the position of the program drum. There is a tolerance on the make and break time of the program cam contacts. *Tolerance* means that the contact action will occur when the contact point is between two given limits. PCC1 will make on the normally open side between column 80% and column 80%. The break time of PCC1 is very critical and should be adjusted very accurately. PCC1 is adjusted to break at column 88%.

PCC2 shows a tolerance on both the make and break time. These timings refer to the normally closed contact. The diagram shows that the operating point will make on the normally closed side between column 87% and column 88%, and will break between column 82% and column 84.

Keyboard Electrical Functions

Pressing a key on the keyboard forces a keystem down and actuates a permutation bar. This mechanical linkage closes a latch contact, a bail contact, a keystem contact, or a combination of latch and bail contacts. Certain function keys (other than character keys) close keystem contacts only. All permutation bars do not operate both latch and bail contacts. The keyboard reference chart on Systems 00.29.10.0 of the wiring diagram shows all the combinations of contacts, the card code, and the symbol associated with each keystem.

The combination keyboard wiring schematic is shown on Systems 00.29.03.1 of the wiring diagram. The latch contacts are labeled "L", and the bail contacts are labeled "B". Their associated keystems, the symbol, and the card code are shown on Systems 00.29.10.0.

The combination keyboard voltage input is shown in 3B. The common voltage line, used in both alpha and numeric shift, is through connector C10 and is controlled by a card lever relay N/O point and the keyboard restore bail N/C contact.

The alpha voltage line for the 64-character keyboard is through connector C16 and is controlled by an alpha relay N/O point, card lever relay N/O point, and the keyboard restore bail N/C contact.

The numeric voltage line for the 64-character keyboard is through connector C14 and is controlled by an alpha relay N/C point, card lever relay N/O point, and the keyboard restore bail N/C contact.

Refer to Systems 01.29.18.0 for the voltage distribution to the keyboard restore bail contact from the power supply.

The "C" and "Z" edge connectors distribute the keyboard (both numeric and combination) voltages. Systems 01.29.02.1 shows the latch contacts of the numeric keyboard and the interposer magnets. The 13 interposer magnets are connected to either the numeric or combination keyboard through the "Z" edge connector.

The even-numbered bail contacts are on the left side of the keyboard, and the odd-numbered bail contacts are on the right side of the keyboard (as viewed from the front of the keyboard).

The latch contact number is the same as its associated keystem number. When the U1 key, keystem position 28, is pressed, its latch contact (28) energizes the 1 interposer magnet if the keyboard is in numeric shift. In alpha shift, the +48 volt circuit to the 28 latch contact is broken by alpha relay N/C points, and the only active output is through 1- and 7-bail contacts. The output of the 1-bail contact energizes the

0 interposer magnet, and the output of the 7-bail contact energizes the 4 interposer magnet during the same punch cycle. The 0- and 4-card code is the letter U.

Certain latch contacts and bail contacts are in the +48 volt common circuit (refer to Systems 00.29.03.1). These latch contacts and bail contacts are not affected by alpha or numeric keyboard shifting and always produce the same punch code. *Example:* The B! key (23) latch contact always punches a 2-code (refer to Systems 00.29.10.0). Note that the bail contacts associated with the B! key (23) are 15, 10, and 8. The 23 latch contact is in the common circuit, the 15 bail contact is in the alpha circuit, the 10 bail contact is in the numeric circuit, and the 8 bail contact is in the numeric circuit.

Therefore, when a key is pressed, all its individual contacts close, but only those controlled to operate by keyboard shift energize the interposer magnets. The number of the latch or bail contact does not necessarily mean that the same interposer magnet will operate. The keys on the keyboard operating keystem contacts do not operate latch or bail contacts and are not under control of the interlock disks.

Use the keyboard reference chart on Systems 00.29.10.0, 01.29.02.1, and 00.29.03.1 with reference to each other for further understanding of the keyboards. Note that the "A" key (keystem 5) and the "Z" key (keystem 7) are not combination keys and will lock up when pressed in numeric shift.

Index

Alpha Key	6-2	Eject Station	1-4
Auto Dup Speed	1-8	Electrical Symbols and Identification	B-1
Auto Feed Switch	6-2	End of Card	
Auto Skip/Auto Dup Switch	6-1	Auto Feed Switch Off	3-3, 3-25
Automatic Duplication		Auto Feed Switch On	3-3, 3-25
Alphabetic Information	6-7	Energizing Interposer Magnets	2-26
First Column of Card	1-8	Error Reset	
Numeric Information	6-7	Key	6-3
Operation	3-11, 3-33	Key Operation	3-3, 3-25
Automatic Skip Programming	6-7	Escape Magnet Armature	1-8
Automatic Skipping	3-15, 3-37	Escapement	6-4
Aux Dup Key	6-3	Friction Clutch	2-2
Backspace		Magnet Assembly	2-4
Key	6-1	Features	4-1
Key Operation	3-6, 3-28	Feed Key	6-3
Mechanism	2-5	First Depression	3-4, 3-26
Bail and Latch Contacts	2-18	Operation	3-3, 3-25
Base Machine	B-1	Second Depression	3-4, 3-26
Card Escapement	1-7	Feed Knife Operating Link	2-7
Card Feed and Punch		Feed Knives and Card Hopper	2-8
Circuit Breakers	2-15	Feed Rolls and Pressure Rolls	2-7
Mechanical Timing Charts	1-7	Field Definition Punches	6-6
Card Feed		Field Size	4-1
Clutch	2-4	Friction Clutch and Escapement Mechanism	2-2
Detail Station and Punch Station	1-4	Functional Keyboard Keys	6-2
Index	2-7	Functional Operations	6-4
Latch Magnet	2-7	Insert/Stack MC Insert Switch	6-1
Latch Magnet Assembly	2-5	Interlock Circuits	6-3
Mechanical Action	2-7	Interlock Disks	2-20
Card Hopper	1-4	Interposer	
Feed Knives	2-8	Bail Contacts	1-7, 2-26
Card Lever Contacts	2-15	Magnets	2-26
Card Movement	1-1	Selection	6-4
Card Printing	1-4	Keyboards	1-6
Card Punch Voltages	5-1	Electrical Functions	B-2
Card Registering	1-3	Interlocks	2-20
Mechanics	2-11	Mechanics	2-15
Card-to-Card Skip		Restore Magnets	6-4
Auto Feed Switch On	3-5, 3-27	Restoring Components	2-18
Speed	1-8	Shifting	6-2
Card Transport	6-4	Keys, Switches, and Indicators	6-1
CF		Left-Zero Insertion Feature	4-1
Clutch	1-7	Credit Field	4-8, 4-19
Latch Magnet	1-7	Credit Read In	4-8, 4-19
Shaft	1-7	Credit Read Out, Punch Out	4-8, 4-19
Character Keys	6-3	Error Reset Key	4-1
Circuit Card	2-34	Logic Controls	4-10, 4-22
Clear		Print Operation	3-21, 3-44
Operation	3-20, 3-42	Print Switch	6-2
Switch	6-2	Program Card	4-1
Clutch and Magnet Assemblies	2-3	Read In	4-1, 4-10
Code Plate	2-40	Read Out, Punch Out	4-5, 4-15
Column Indicator	6-1	Relays	4-1
Combination Keyboard	6-3	Location Chart (Wiring Diagram)	1-7
Console and Maintenance Features	6-1	Machine	
Continuously Running Mechanism	2-1	Characteristics	A-1
Cycles and Timings	1-7	Wiring Diagram	1-6
Data Cards	1-1	Magnet and Clutch Assemblies	2-3
Detail Card	1-4	Main Line Switch	6-1
Lever (N/O Contact)	1-7	Manual Alphabetic Field	6-7
Drive Mechanism	2-1	Manual Duplication	
Drum Interlock	2-29	More Than One Column	3-9, 3-31
Dummy Punch Clutch Cycle	3-6, 3-28	One Column, Program Control Off	3-6, 3-28
Dup Key	6-3	Operation (Program Control On)	3-11, 3-33
Duplication	3-6, 3-28	Program Control On	6-8
Edge (SMS Card) Connectors	2-36	Sequence Chart	3-8, 3-30

Manual Dup Speed	1-8
Manual Numeric Field	6-7
Manual Punching Operation	3-1, 3-23
Manual Skip	
Operation — Program Control Off	3-13, 3-35
Operation — Program Control On	3-15, 3-37
Program Controlled	6-7
Manually Inserting and Registering Cards	6-5
Master Card	1-4
Insertion Switch	6-1
Lever	2-31
Master Station and Read Station	1-4
Mechanical	
Relationship — Punch Index and Escapement	3-8, 3-30
Timing Chart	2-7
Motor Control Switch	6-4
Multipunch (Multiple Punching) Operation	3-15, 3-37
Key	6-3
Normally Closed Reed Switch	2-33
Numeric	
Alphabetic Information	6-5
Key	6-2
Keyboard	6-3
On/Auto Feed Switch	6-2
On/Auto Skip Dup Switch	6-1
On/Clear Switch	6-2
On/LZ Print Switch	6-2
On/Print Switch	6-2
One/Two Prog Sel Switch	6-1
Operating Instructions	6-4
PCC1 (Program Cam Contact 1)	1-8
PCC2 (Program Cam Contact 2)	1-8
Permutation Bar	2-17
Pin Bail and Pin Bail Arm	2-31
Pin Sensing Unit Mechanics	2-30
Positive Code Plate Stops	2-42
Power On	5-2
Power Supplies and Control	5-1
Pressure Roll Linkage and Card Registration	2-11
Print	
Character Pattern Chart	2-44
Control	3-20, 3-44
Interposers	2-42
Mechanics	2-38
Pressure Plate	2-43
Suppression Mechanism	2-44
Switch	6-2
Timing Chart	2-44
Wire Restoring Heads	2-40
Prog 1 Key	6-3
Prog 2 Key	6-3
Program	
Cam Contacts	2-30
Card Preparation	4-1, 6-6
Control Lever (Handle), Release Bail, and Drum Interlock	2-28
Drum Installing	6-6
Handle Switches 1 and 2	2-29
Levels (Program 1 and Program 2)	3-1, 3-23
Select Switch	6-1
Sensing Mechanism	2-28
Shaft	2-28
Unit	1-4
Punch	
Extensions and Code Plate Shifting	2-42
Index and Escapement (Mechanical Relationship)	3-8, 3-30
Operating Arm	2-24
Registration	1-3
Punch Clutch	1-8
Armature	1-8
Cycle	1-7
Magnet Assembly	2-5
Punch, Die, and Stripper	2-27
Punch Drive	
Cycle	6-4
Mechanics	2-21
Shaft	1-7
Unit	2-22
Punching and Reading Sequence	1-3
Read Card Lever	
Contact	1-7
N/O Contact	6-3
Reed Relay	
Contact Bounce (N/C)	2-34
Contact Bounce (N/O)	2-34
Normally Closed Contacts (N/C)	2-33
Normally Open Contacts (N/O)	2-33
Operate Time (Pick Up)	2-33
Relay Identification	2-34
Relay Package	2-34
Relay Terminology	2-33
Release Time (Drop Out)	2-33
Switching Methods	2-33
Switching with Electromagnetic Action	2-33
Reg Key	6-3
Register Key Operation	3-5, 3-27
Registration	
Mechanics	1-3
Stop Plate	2-13
Rel Key	6-3
Release Bail	2-28
Release Key	
Auto Dup Field	3-19, 3-41
Auto Skip Field	3-19, 3-41
Blank Field	3-18, 3-40
Manual Field	3-18, 3-40
Not Programmed, with Cards	3-17, 3-38
Without Cards	3-18, 3-39
Release — Program Control On, with Cards	3-18, 3-40
Ribbon Feed	2-46
Sensing Pin Separator	2-32
Sensing Pins and Contacts	2-32
Sequence of Operations	6-4
Shifting the Keyboard	6-3
Skipping	3-13, 3-35
SMS	
Card Receptacles	2-37
Location and Pin Numbering	2-37
Printed Wiring Cards	2-36
Skip Key	6-3
Space Bar	6-3
Space Interposer	2-26
Special Character Codes (Combination Keyboard)	2-20
Stacker	
Assembly	1-4
N/C Contact	2-14
Switch	6-3
Standard Modular System (SMS)	6-1
Start and Run	2-36
Starwheels	
Contacts	6-4
Sensing Contacts	1-7
Switch Panel, Toggle Switches	2-29
Switches	6-1
Timings and Cycles	6-1
Toggle Switches on Switch Panel	1-7
Unit Operation	6-1
Wire Contact Relays	6-5
Wiring Diagrams	2-37
Symbology	7-1
B-1	

READER'S COMMENT FORM

29 Card Punch, FETOM

S225-3358-4

● How did you use this publication?

- As a reference source
- As a classroom text
- As

● Based on your own experience, rate this publication...

- As a reference source:
.....
Very Good Fair Poor Very
Good Poor
- As a text:
.....
Very Good Fair Poor Very
Good Poor

● What is your occupation?

● We would appreciate your other comments; please give specific page and line references where appropriate. If you wish a reply, be sure to include your name and address.

YOUR COMMENTS, PLEASE

Your answers to the questions on the back of this form, together with your comments, will help us produce better publications for your use. Each reply will be carefully reviewed by the persons responsible for writing and publishing this material. All comments and suggestions become the property of IBM.

Please note: Requests for copies of publications and for assistance in utilizing your IBM system should be directed to your IBM representative or to the IBM sales office serving your locality.

fold

fold



NO POSTAGE
NECESSARY
IF MAILED
IN THE
UNITED STATES

BUSINESS REPLY MAIL
FIRST CLASS PERMIT NO. 40 ARMONK, N.Y.

POSTAGE WILL BE PAID BY ADDRESSEE:

**IBM CORPORATION
P.O. BOX 390
POUGHKEEPSIE, N.Y. 12602**



ATTENTION: FE MANUALS, DEPT. B96

fold

fold



International Business Machines Corporation
Data Processing Division
1133 Westchester Avenue, White Plains, New York 10604
(U.S.A. only)

IBM World Trade Corporation
821 United Nations Plaza, New York, New York 10017
(International)