

7900 Disc Maintenance

student workbook

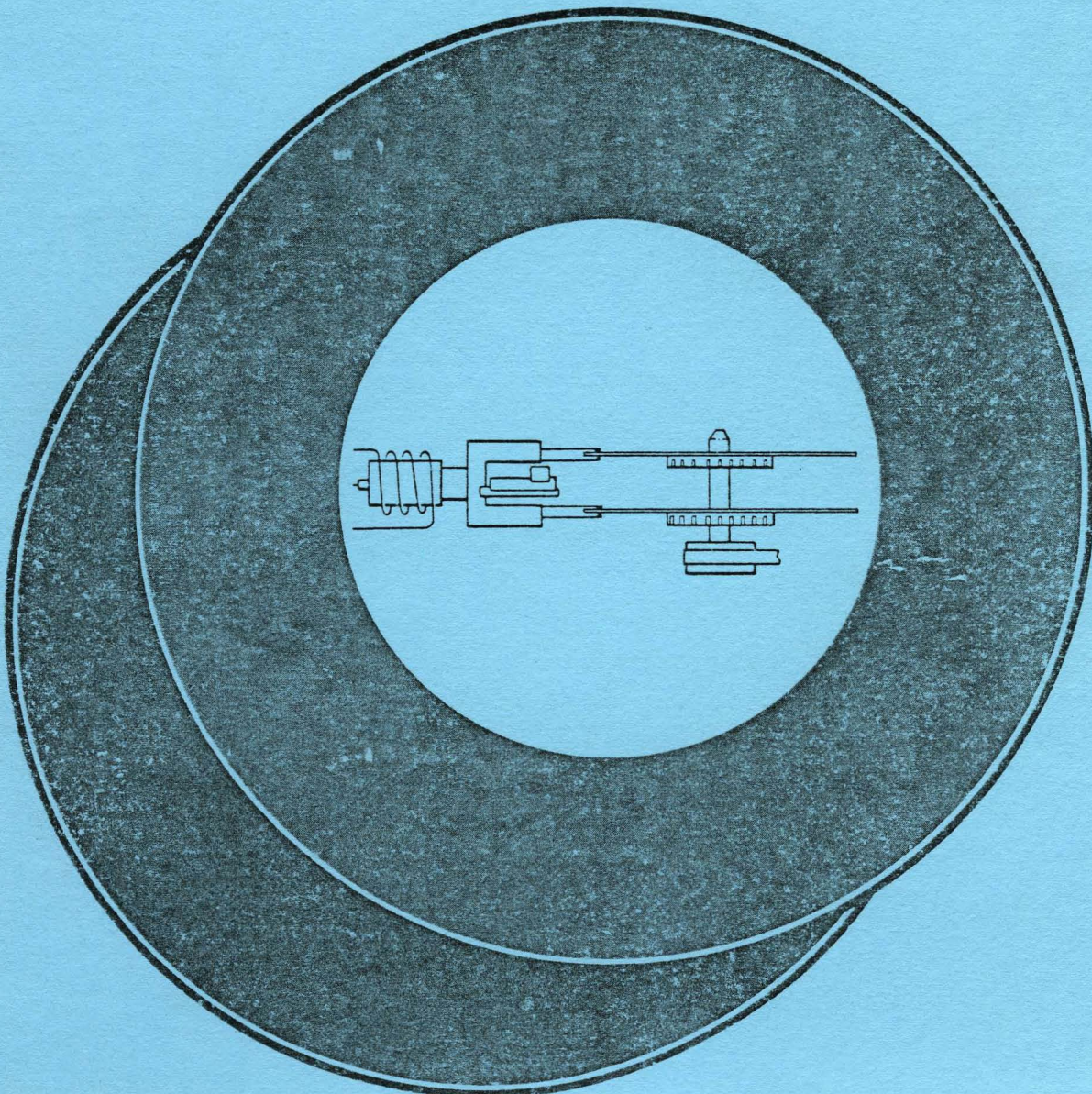



7900 Disc Maintenance

STUDENT WORKBOOK

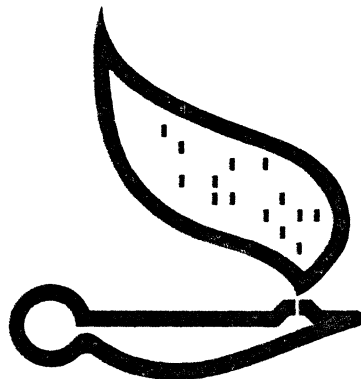

**data systems
training center**

list of effective pages

Changed pages are designated by a change date in the lower corner of the page. Original pages do not indicate a changed date. Insert latest changed pages and destroy superseded pages.

PAGE NUMBER	ISSUE	PAGE NUMBER	ISSUE
Title	Original	3-0 Thru 3-59	Original
ii Thru iv	Original	4-0 Thru 4-76	Original
1-0 Thru 1-4	Original	Back Cover	Original
2-0 Thru 2-24	Original		

preface

The student study guide provides the necessary study materials to complete this course. The materials follow the same sequence as the classroom lecture. The organization of the materials within each section of the guide follows the modularity of the course as described in the training schedule.

Section I contains an overview of the course, its objectives, prerequisites, list of required materials and class schedule.

Section II contains handouts of materials which are not available in texts handed out in class. Copies of pertinent overhead transparencies, used in the lecture portion of the class, are also included.

Section III contains copies of the exercises/lab projects. Depending on which class you are enrolled in, you may not do all of the lab projects. This section may also contain copies of quizzes and tests, or the instructor may hand these out later.

Section IV contains reference materials related to the course but not absolutely necessary to meet the objectives of the course.

contents

SECTION

I INTRODUCTION AND OVERVIEW

Level 1

Course Description	1-1
Course Objectives	1-1
Course Prerequisites	1-1
General Outline	1-2
Document Handout List	1-2

Level 2

Course Description	1-3
Course Objectives	1-3
Course Prerequisites	1-3
General Outline	1-4
Document Handout List	1-4

II HANDOUTS

7900 Interface	2-1
7900 Disc Signal Definitions	2-2
Relay Enable Circuitry	2-5
Position of PC Boards	2-7
Disc Format	2-8
Sectors	2-8
Addressing Structure	2-9
Data Rate and Capacity	2-10
Sector Format	2-11
Head Support	2-11
Erase Flux	2-12
Drive Enabled Circuitry	2-13
Starting	2-14
Spindle Motor Control	2-15
Seek Control	2-16
Carriage Control	2-17
Carriage Position Control	2-18
Carriage Direction Control	2-19
Actuator Speed Control	2-19
Servo Amplifier	2-20
Sector Address Comparison	2-21
Sector Detect	2-21
Data Lines Driver and Receivers	2-22
Data Control	2-22
Read Circuitry	2-23
Size and Speed	2-24

SECTION

III EXERCISES/LAB PROJECTS

Laboratory Procedures	3-1
Exercise/Lab Project 1	3-3
Exercise/Lab Project 2	3-7
Exercise/Lab Project 3	3-11
Exercise/Lab Project 4	3-19
Exercise/Lab Project 5	3-27
Exercise/Lab Project 6	3-31
Answers To Exercise 6	3-39
Fault Isolation Reports	3-45

IV REFERENCE MATERIALS

Troubleshooting/Aids	4-1
Troubleshooting Techniques	4-8
Shoot The Moon	4-11
Baby Sitter	4-14
IC Diagrams	4-16

SERVICE NOTES

Spare Parts	4-23
Tools and Test Equipment	4-28
Installation Procedures	4-30
Head Disc Interference	4-36
Drive Fault	4-38
Encoder PCA	4-40
Trickle Charge	4-44
Cartridge Receiver	4-45
Operational Amplifier	4-46
Motor Power Module	4-47
PM Schedule	4-48
Operator Precaution	4-50
Static Discharge Strap	4-51
Encoder Lamp Replacement	4-52
Head Alignment	4-53
Spare Parts	4-57
HP7901 Tools	4-65
HP7901 Installation	4-67
HP13210 Improvement	4-70
Intermittent Data Errors	4-72
Daisy Chaining	4-73
Intermittent Seek	4-74
Multi-Drive Environment	4-75
HP7901 Power Supply Fuse Label	4-76

introduction and overview

SECTION
I

handouts

SECTION
II

exercises/lab projects

SECTION
III

reference materials

SECTION
IV

introduction and overview

SECTION

I

SECTION I

CONTENTS

INTRODUCTION AND OVERVIEW

LEVEL 1

Course Description	1-1
Course Objectives	1-1
Course Prerequisites	1-1
General Outline	1-2
Document Handout List	1-2

LEVEL 2

Course Description	1-3
Course Objectives	1-3
Course Prerequisites	1-3
General Outline	1-4
Document Handout List	1-4

INTRODUCTION AND OVERVIEW

COURSE DESCRIPTION.

This course provides classroom theory and laboratory troubleshooting experience on the HP7900A Disc Drive and the HP13210 Interface Subsystem to the extent that the student can maintain the disc drive to the board level in the field. This course is a prerequisite for the 7900A Level 2 maintenance course.

COURSE LENGTH.

Five days.

COURSE OBJECTIVES.

To familiarize the student with the HP7900A Disc Drive and subsystem to the extent that the student can accomplish the following:

1. Board level repair the HP7900A Disc Drive.
2. Be able to make all mechanical and electrical adjustments to the extent the drive will meet all specification and compatibility requirements.
3. Board level repair the HP13210 Interface for the disc drive.
4. Use the HP13219 Disc Drive Service Unit to troubleshoot and maintain the HP7900A Disc Drive.
5. Be able to accomplish all preventive maintenance procedures.
6. Use the Cartridge Disc Memory Diagnostic 7900/13210 to board level repair and maintain the HP7900A Disc Drive by:
 - a. Interpreting the error messages for troubleshooting.
 - b. Write I/O program loops using the instructions provided by the diagnostic.

COURSE PREREQUISITES.

Mini-computer Maintenance course or equivalent field experience.

GENERAL OUTLINE.

- I. Day 1. Morning.
 - A. Intro to HP7900 Class.
 - B. Intro to HP7900 Disc Drive.
 - C. The Storage Media.
 - D. The HP7900 Heads.
 - E. Spindle Motor Heads.
- II. Day 1. Afternoon.

The students will do Lab Projects 1 and 2.
- III. Day 2. Morning.
 - A. Carriage positioning.
 - B. Sector detection.
- IV. Day 2. Afternoon.

The students will do Lab Projects 3 and 4.
- V. Day 3. Morning.
 - A. Data
 - B. 7901 Differences.
 - C. Diagnostics
- VI. Day 3. Afternoon.

The students will do Lab Project 5 and using the operator design section of the diagnostics scope the Read/Write circuits.
- VII. Day 4. Morning.

HP13210 Logics
- VIII. Day 4. Afternoon.

Troubleshooting Lab.
- IX. Day 5

Troubleshooting Lab.

DOCUMENT HANDOUT LIST.

1. *HP7900A Disc Drive Operating & Service Manual (07900-90002).*
2. *HP13215A Disc Power Supply Operating & Service Manual (13215-90003)*
3. *7900 Student Study Guide (07900-90037).*
4. *HP7900 Disc Drive Service Training Manual (07900-90022).*
5. *HP7901 Disc Drive Operating & Service Manual (07900-90003).*
6. *HP7900/13210 Cartridge Disc Memory Diagnostics (13210-90004).*
7. *HP13210 Disc Drive Subsystem Operating & Service Manual (13210-90003).*

INTRODUCTION AND OVERVIEW

COURSE DESCRIPTION.

This course provides classroom theory and laboratory troubleshooting experience on the HP7900 Disc Drive and the HP13210 Interface Subsystem to the extent that the student can maintain the disc drive to the component level in the field.

COURSE LENGTH.

Three days.

COURSE OBJECTIVES.

To familiarize the student with the HP7900/01A and subsystem to the extent that the student can accomplish the following items:

1. Component level repair the HP7900/01A Disc Drive
2. Component level repair the HP13210 Interface for the HP7900/01A Disc Drive

COURSE PREREQUISITES.

1. Mini-computer Maintenance course or equivalent field experience to the extent that the course objectives can be met.
2. HP7900/01A Level 1 course or equivalent field experience on the HP7900 Disc Drive.

GENERAL OUTLINE

- I. Day 1. Morning.
 - A. Introduction to HP7900 Level 2 Class.
 - B. Review of Sequence of Events and Handshake Signals.
 - C. Review of Power Up and Interlock System.
 - D. Spindle Motor Control.
 - E. Loading The Heads, Return To Home, and Retract Operations.
- II. Day 1. Afternoon.

Troubleshooting the areas of the drive covered by the lecture to this point.
- III. Day 2. Morning.
 - A. Carriage Positioning.
 - B. Sector Detection.
 - C. Data.
- IV. Day 2. Afternoon.

Troubleshooting the areas of the drive covered by the lecture to this point.
- V. Day 3. Morning.

HP13210 Interface Logic.
- VI. Day 3. Afternoon.
 - A. Troubleshooting the HP13210 Drive and Interface Subsystem.
 - B. Test
 - C. Course Critique

DOCUMENT HANDOUT LIST.

1. *HP7900A Disc Drive Operating & Service Manual (07900-90002)*
2. *HP13215A Disc Power Supply Operating & Service Manual (13215-90003)*
3. *HP7900 Student Study Guide (07900-90037)*
4. *HP13210 Disc Drive Subsystem Operating & Service Manual (13210-90003).*

handouts

SECT
I

SECTION II

CONTENTS

7900 Interface	2-1
7900 Disc Signal Definitions	2-2
Relay Enable Circuitry	2-5
Position of PC Boards	2-7
Disc Format	2-8
Sectors	2-8
Addressing Structure	2-9
Data Rate and Capacity	2-10
Sector Format	2-11
Head Support	2-11
Erase Flux	2-12
Drive Enabled Circuitry	2-13
Starting	2-14
Spindle Motor Control	2-15
Seek Control	2-16
Carriage Control	2-17
Carriage Position Control	2-18
Carriage Direction Control	2-19
Actuator Speed Control	2-19
Servo Amplifier	2-20
Sector Address Comparison	2-21
Sector Detect	2-21
Data Line Drivers and Receivers	2-22
Data Control	2-22
Read Circuitry	2-23
Size and Speed	2-24

7900 INTERFACE

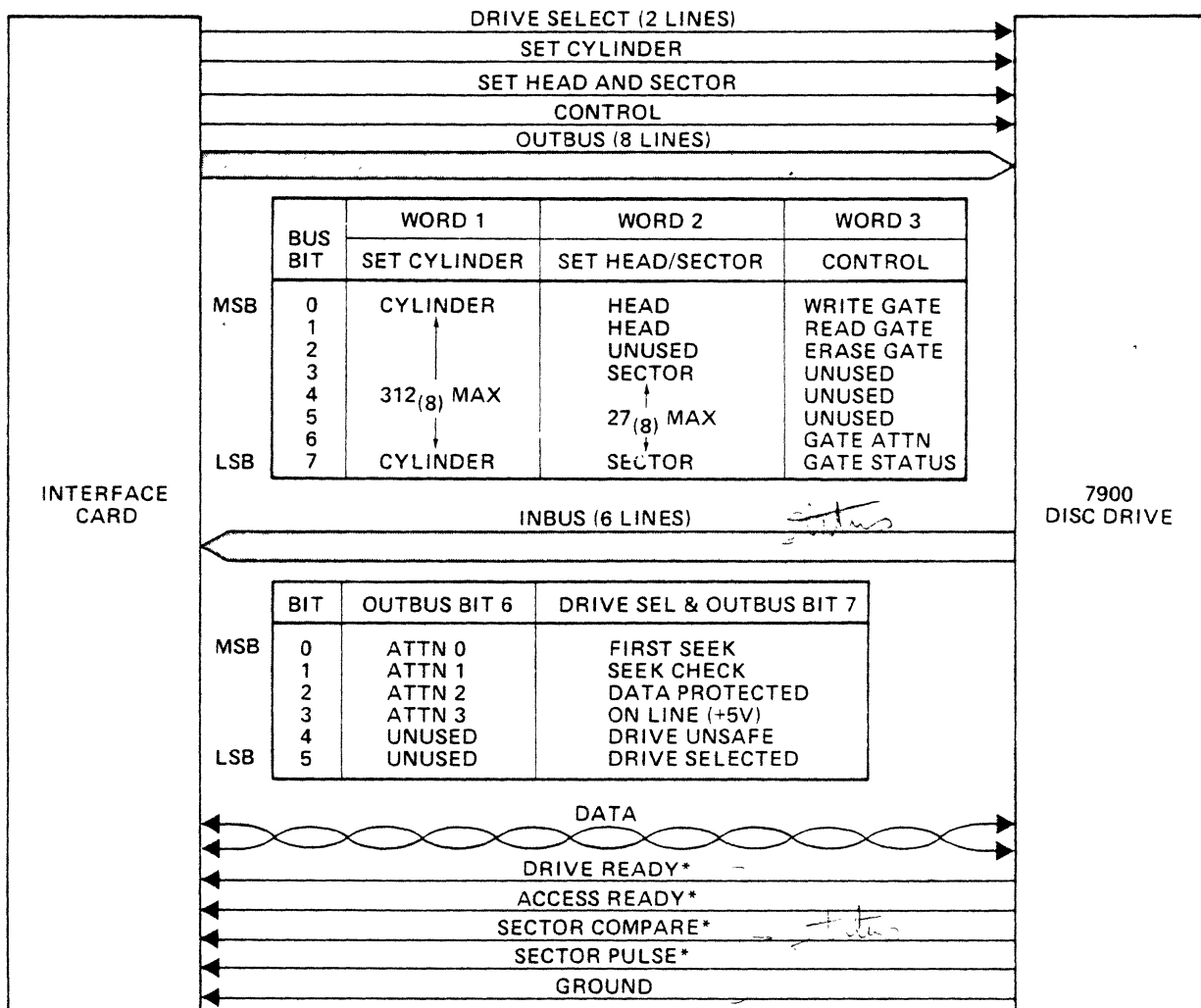

*LINE ACTIVE ONLY WHEN DRIVE SELECTED

7900 DISC SIGNAL DEFINITIONS

SIGNAL LINE	FUNCTION
$\overline{\text{Set Cylinder}}$	This pulse samples $\overline{\text{Outbus 0}}$ thru $\overline{7}$ for a new cylinder address. The address is stored in a register within the disc drive, and movement of the carriage to the new location is started. This movement is called a seek.
$\overline{\text{Outbus 0}}$	This part of the cylinder address is stored in a register within the disc drive by $\overline{\text{Set Cylinder}}$. This part of the head address is stored in a register within the disc drive by $\overline{\text{Set Head}}$. This is part of the memory control. This signal must be maintained by the disc drive controller during the entire memory operation.
$\overline{\text{Outbus 1}}$	This part of the cylinder address is stored in a register within the disc drive by $\overline{\text{Set Cylinder}}$. This part of the head address is stored in a register within the disc drive by $\overline{\text{Set Head}}$. This is part of the memory control. This signal must be maintained by the disc drive controller during the entire memory operation.
$\overline{\text{Outbus 2}}$	This part of the cylinder address is stored in a register within the disc drive by $\overline{\text{Set Cylinder}}$. This is part of the memory control. This signal must be maintained by the disc drive controller during the entire memory operation.
$\overline{\text{Outbus 3}}$	This part of the cylinder address is stored in a register within the disc drive by $\overline{\text{Set Cylinder}}$. This part of the sector address is stored in a register within the disc drive by $\overline{\text{Set Head}}$.
$\overline{\text{Outbus 4}}$	This part of the cylinder address is stored in a register within the disc drive by $\overline{\text{Set Cylinder}}$. This part of the sector address is stored in a register within the disc drive by $\overline{\text{Set Head}}$.
$\overline{\text{Outbus 5}}$	This part of the cylinder address is stored in a register within the disc drive by $\overline{\text{Set Cylinder}}$. This part of the sector address is stored in a register within the disc drive by $\overline{\text{Set Head}}$.
$\overline{\text{Outbus 6}}$	This part of the cylinder address is stored in a register within the disc drive by $\overline{\text{Set Cylinder}}$. This part of the sector address is stored in a register within the disc drive by $\overline{\text{Set Head}}$. Enables the Attention status bits of all four disc drives to appear on $\overline{\text{Inbus 0}}$ thru $\overline{3}$ lines.
$\overline{\text{Outbus 7}}$	This part of the cylinder address is stored in a register within the disc drive by $\overline{\text{Set Cylinder}}$. This part of the sector address is stored in a register within the disc drive by $\overline{\text{Set Head}}$. Enables the First Status, Seek Check, Surface Disable, +5V, and Drive Unsafe status bits of the currently addressed disc drive to appear on $\overline{\text{Inbus 0}}$ thru $\overline{4}$ lines, respectively.
$\overline{\text{Select 1}}$ $\overline{\text{Select 2}}$	Most significant bit of the drive address. Least significant bit of the drive address. These two lines contain the binary-coded logical address of a disc drive. Each one of the four disc drives decodes the address. Only the addressed disc drive will respond to commands and return status. These signals are levels, not pulses, and must be maintained during the entire disc drive operation.

7900 DISC SIGNAL DEFINITIONS (CONTINUED)

SIGNAL LINE	FUNCTION
$\overline{\text{Set Head}}$	This pulse samples $\overline{\text{Outbus 0}}$ thru $\overline{7}$ for new head and sector addresses. The addresses are stored in a register within the disc drive, and comparison of the new (desired) sector address with the current sector position of the disc drive is started.
$\overline{\text{Control}}$	This line enables the memory function specified by $\overline{\text{Outbus 0}}$, $\overline{\text{Outbus 1}}$, and $\overline{\text{Outbus 2}}$. The $\overline{\text{Control}}$ signal must remain false during the entire data transfer. If $\overline{\text{Outbus 7}}$ is low when $\overline{\text{Control}}$ is low, then the Attention flip-flop (see below) on the currently addressed disc drive will be cleared.
R/W Data 1 R/W Data 2	These two lines constitute a bi-directional differential pair of signal lines. The signal transferred in either direction is a combination of data multiplexed with a data recovery clock.
Attention	This status signal becomes high when a seek (head movement to new position) is successfully completed. It is cleared by: $\overline{\text{CONTROL}} \cdot \overline{\text{OUTBUS 7}} \cdot \overline{\text{DRIVE ADDRESS}}$ (Select 1 and 2 decoded). This signal appears on Inbus 0, 1, 2, or 3 when Outbus 6 is high.
First Status	This status bit only becomes high when Drive Ready changes from false to true. It becomes false when Attention is cleared (refer to Attention above). This signal appears on the Inbus 0 line of the addressed disc drive when Outbus 7 is high.
Seek Check	This status bit indicates that an illegal addressing function was attempted. The illegal functions which make it high are: <ol style="list-style-type: none"> 1. Cylinder address ≥ 203. 2. Sector address ≥ 24. 3. A seek was attempted while another seek was still in progress. The status bit is cleared by a seek home operation. This signal appears on the $\overline{\text{Inbus 1}}$ line of the addressed disc drive when $\overline{\text{Outbus 7}}$ is low.
Drive Unsafe	This status bit shows that it is not safe to use the disc. It is high if an illegal memory operation was attempted, or if some of the read/write circuitry failed, or if a seek operation did not finish within 850 milliseconds. The disc drive cannot be used until this condition is cleared. It is cleared by turning off the spindle motor (LOAD/UNLOAD switch on front panel) or by connecting the disc service unit which will analyze the error condition. This signal appears on the $\overline{\text{Inbus 4}}$ line of the addressed disc drive when $\overline{\text{Outbus 7}}$ is low.
Data Protect	This bit indicates the status of the write protect switches on the front panel of the disc drive. It is high if the surface selected by the head address is protected against writing; it is low if the surface is not protected. This signal appears on the Inbus 2 line of the addressed disc drive when $\overline{\text{Outbus 7}}$ is low.
Format	When in the OVERRIDE position, this switch puts a low signal on $\overline{\text{Inbus 3}}$. When the controller receives an Initialize Data command, it checks this line: if it is low, it executes the command; if it is high (i.e., switch in PROTECT position), the command channel flag is set and no attempt is made to execute the command.
Sector Pulse	A 24 microsecond pulse at the beginning of each sector. There are 24 pulses per revolution of the disc.

7900 DISC SIGNAL DEFINITIONS (CONTINUED)

SIGNAL LINE	FUNCTION
Sector Compare	<p>This status bit shows the results of a continual comparison between the current sector position of the disc drive and the address held in the sector address register within the disc drive (refer to Set Head above). It can be interpreted in either of the following two ways:</p> <ol style="list-style-type: none"> 1. It is high during the sector before the addressed sector. 2. It is high during the addressed sector. <p>It is low during the rest of the revolution of the disc.</p>
Drive Ready	This status bit indicates that the disc is ready for use; i.e., the heads are over the discs and read/write operations can take place. It becomes low if any one of the conditions necessary for safe operation of the disc drive becomes low.
Access Ready	This status bit indicates that the heads are positioned over the desired cylinder. The address of this cylinder was previously stored in the cylinder address register within the disc drive by the Set Cylinder line. It becomes low with the leading edge of the Set Cylinder pulse, and it becomes high 3 milliseconds (head-settling time) after the new cylinder position is reached.
Inbus 0	$= \overline{\text{OUTBUS 6}} \cdot \underbrace{\text{ATTENTION}}_{\text{(for disc drive 0)}} + \text{OUTBUS 7} \cdot \text{FIRST SEEK} \cdot \underbrace{\text{DRIVE ADDRESS}}_{\text{(Select 1 \& 2 decoded)}}$
Inbus 1	$= \overline{\text{OUTBUS 6}} \cdot \underbrace{\text{ATTENTION}}_{\text{(for disc drive 1)}} + \text{OUTBUS 7} \cdot \text{SEEK CHECK} \cdot \underbrace{\text{DRIVE ADDRESS}}_{\text{(Select 1 \& 2 decoded)}}$
Inbus 2	$= \overline{\text{OUTBUS 6}} \cdot \underbrace{\text{ATTENTION}}_{\text{(for disc drive 2)}} + \text{OUTBUS 7} \cdot \text{SURFACE DISABLE} \cdot \underbrace{\text{DRIVE ADDRESS}}_{\text{(Select 1 \& 2 decoded)}}$
Inbus 3	$= \overline{\text{OUTBUS 6}} \cdot \underbrace{\text{ATTENTION}}_{\text{(for disc drive 3)}} + \text{OUTBUS 7} \cdot +5V \cdot \underbrace{\text{DRIVE ADDRESS}}_{\text{(Select 1 \& 2 decoded)}}$
+5V	This signal appears on the Inbus 3 line of the addressed disc drive when Outbus 7 is low.
Inbus 4	$= \overline{\text{OUTBUS 7}} \cdot \text{DRIVE UNSAFE} \cdot \text{DRIVE ADDRESS} \text{ (Select 1 \& 2 decoded)}$
Inbus 5	This status line indicates that only this disc drive has been selected.

RELAY ENABLE CIRCUITRY

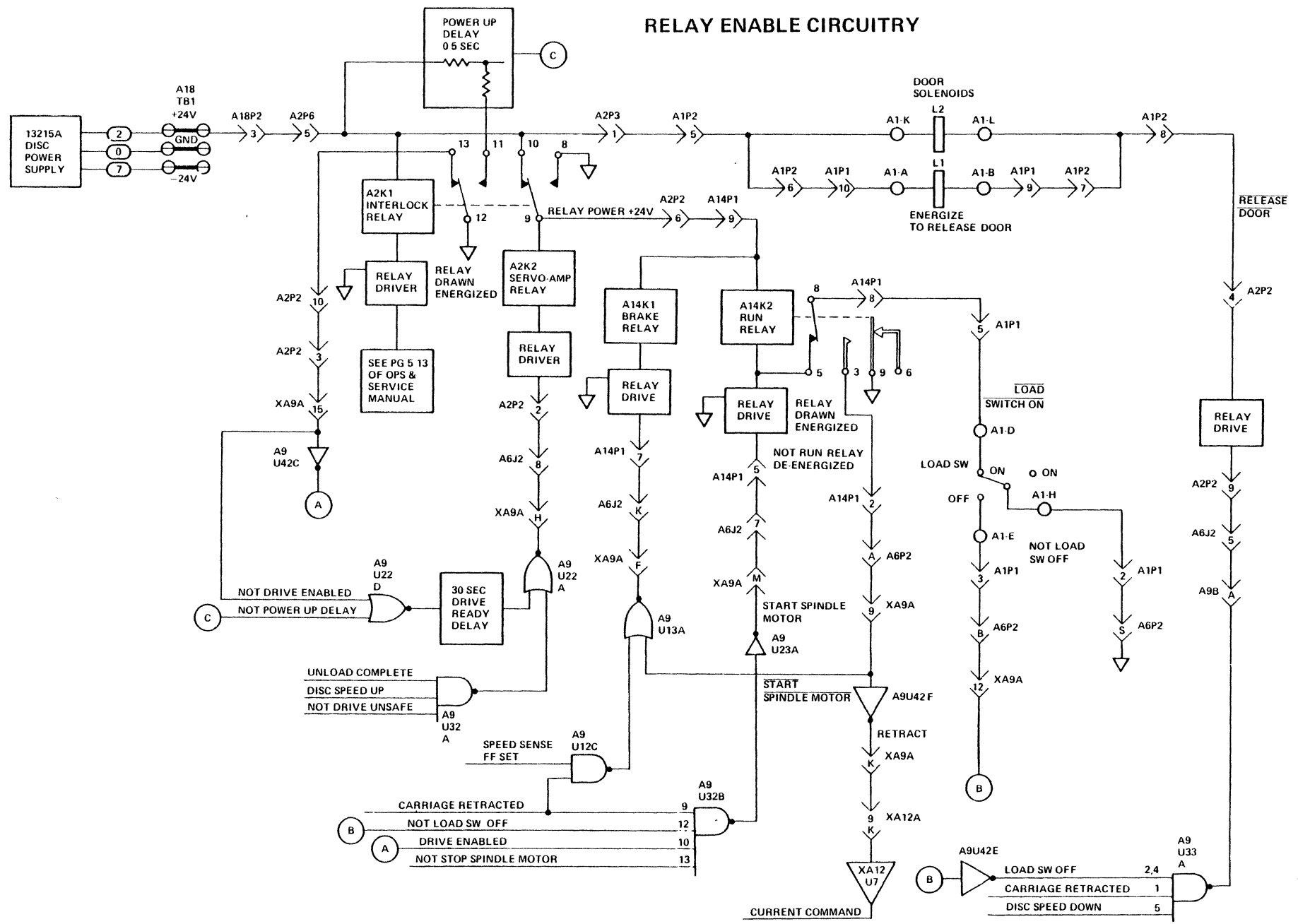

2-5

NOTES

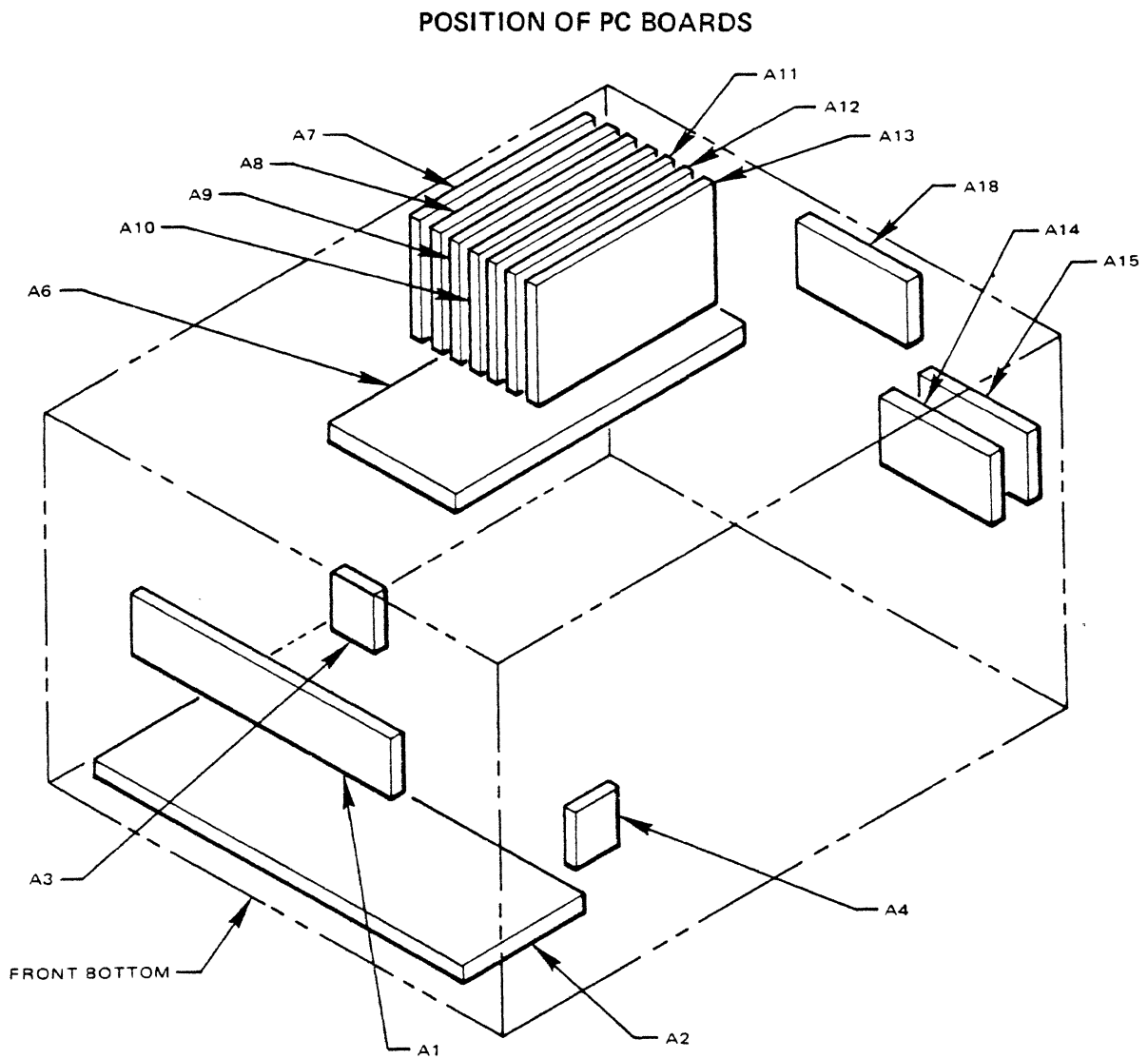

- | | |
|---|--|
| A1 – Front Panel Indicator Assembly | A10 – Read/Write Control |
| A2 – Servo Amplifier and Servo Enable Relay | A11 – Cylinder Address |
| A3 – Sector Transducer (Upper Disc) | A12 – Encoder (Carriage position and movement control) |
| A4 – Sector Transducer (Lower Disc) | A13 – Read Preamplifier and Write Driver |
| A6 – Backplane Motherboard | A14 – DC Brake (Controls for braking spindle motor) |
| A7 – I/O Multiplex | A15 – Motor Control |
| A8 – Sector Count and Compare | A18 – DC Interconnect (Over-voltage protection for +5V, straight-thru transfer for all voltages) |
| A9 – Drive Control | |

DISC FORMAT

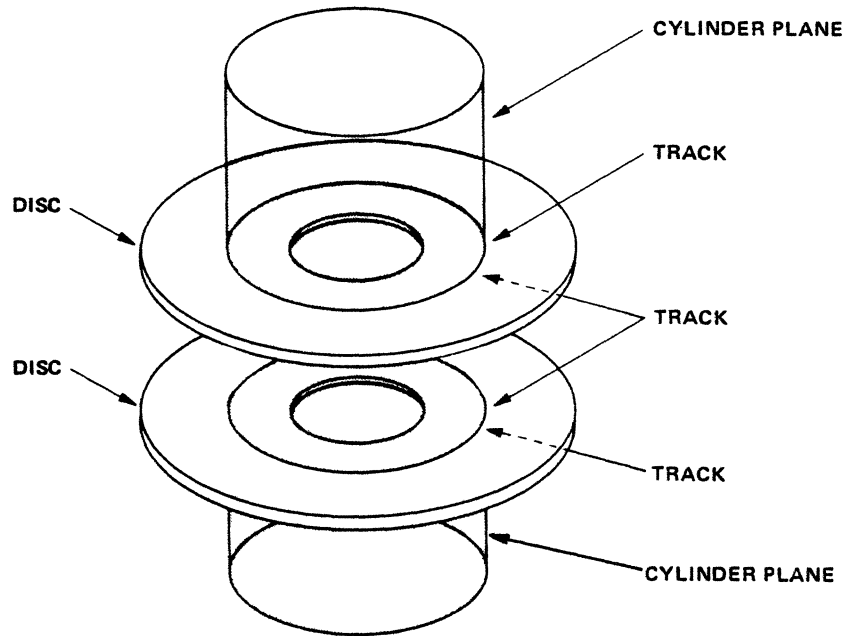

7900 DISC-13

SECTORS

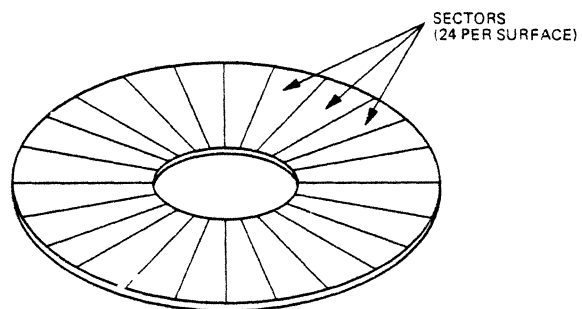

7900 DISC-14

ADDRESSING STRUCTURE

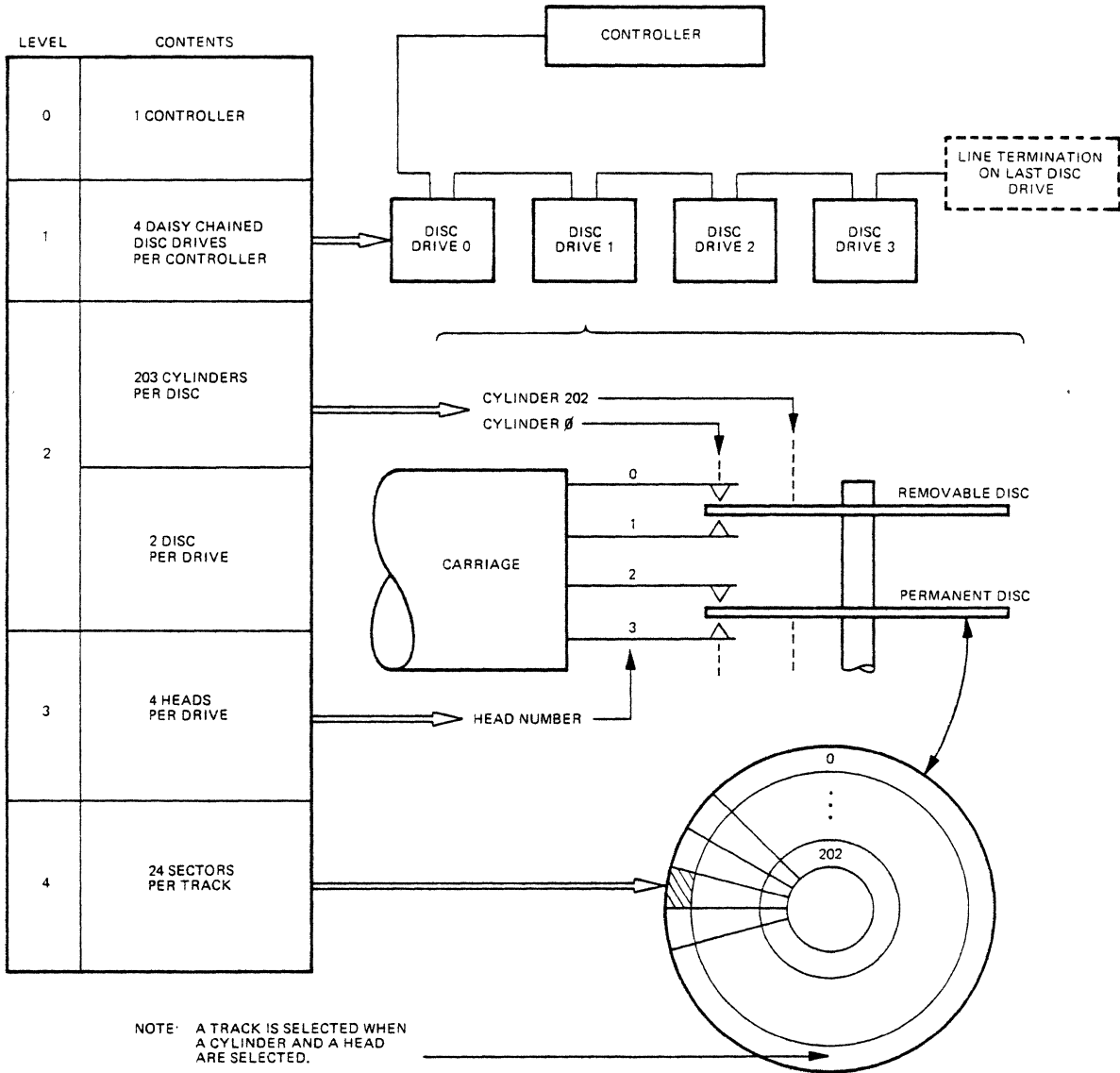

DATA RATE AND CAPACITY

DEFINITIONS

- BIT** — (Binary digIT) smallest unit of data, has two possible values - 0 and 1.
- BYTE** — A group of 8 bits, important because it is a convenient size of data to represent ASCII characters.
- WORD** — A group of 16 bits, important because the architecture of HP computers is based on a word size of 16 bits.

DATA RATE

A bit cell is 400 nanoseconds long. Therefore, the instantaneous data rate

- is --- 2.5 million bits per second,
- or --- 312,500 bytes per second,
- or --- 156,250 words per second.

The data rates above are misleading, because part of each track is used for preambles, addresses, and data checks, and some is not used. The average data rates for usable computer data

- are --- 1.97 million bits per second,
- or --- 245,760 bytes per second,
- or --- 122,880 words per second.

DATA CAPACITY

USABLE DATA CONTAINED

UNIT	WORDS	BYTES	BITS
Word	1	2	16
Sector	128	256	2,048
Track	3,072	6,144	49,152
Cylinder	12,288	24,576	196,608
Side	614,400	1,228,800	9,830,440
Disc	1,228,800	2,457,600	19,660,800
Drive	2,457,600	4,915,200	39,321,600

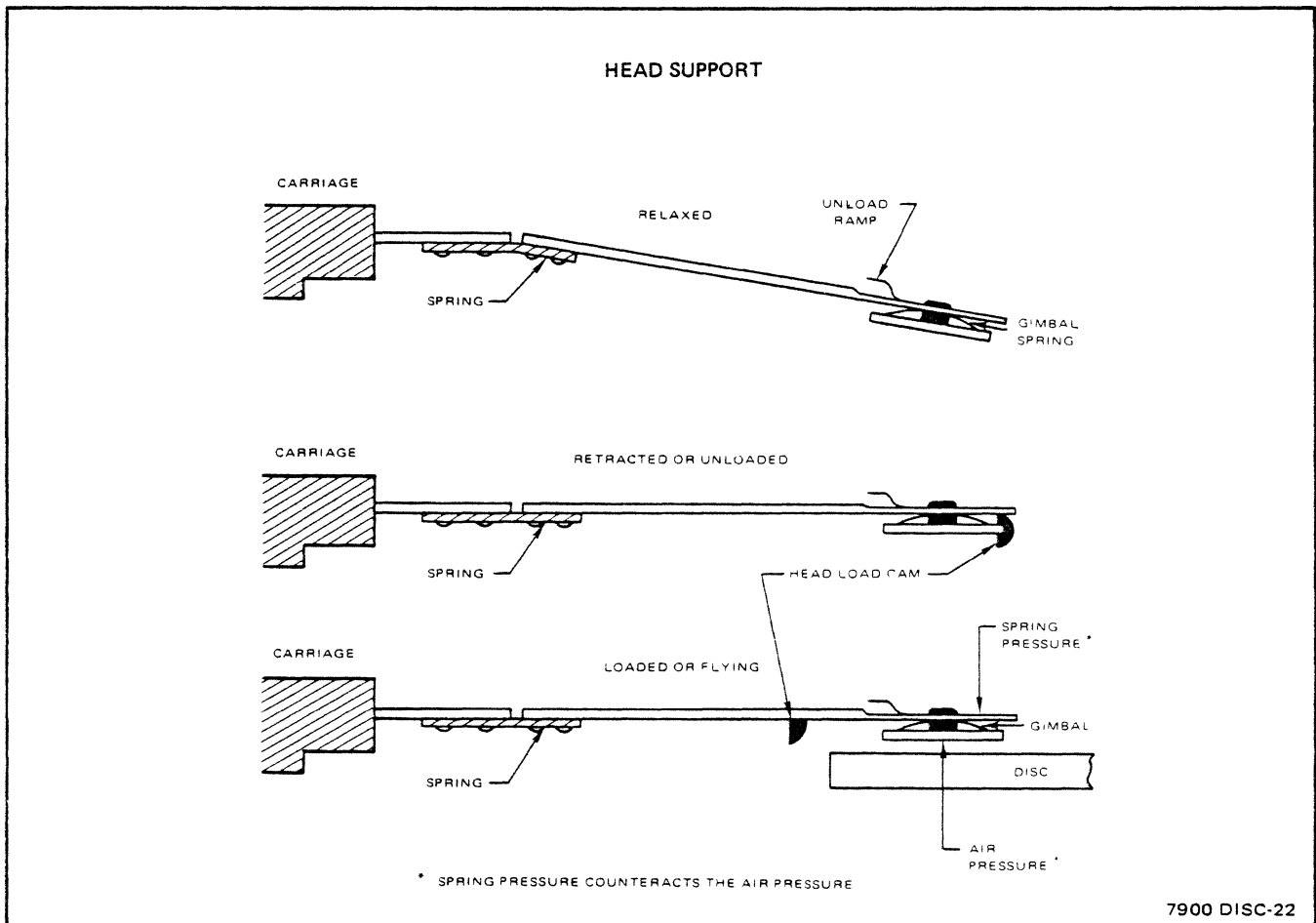
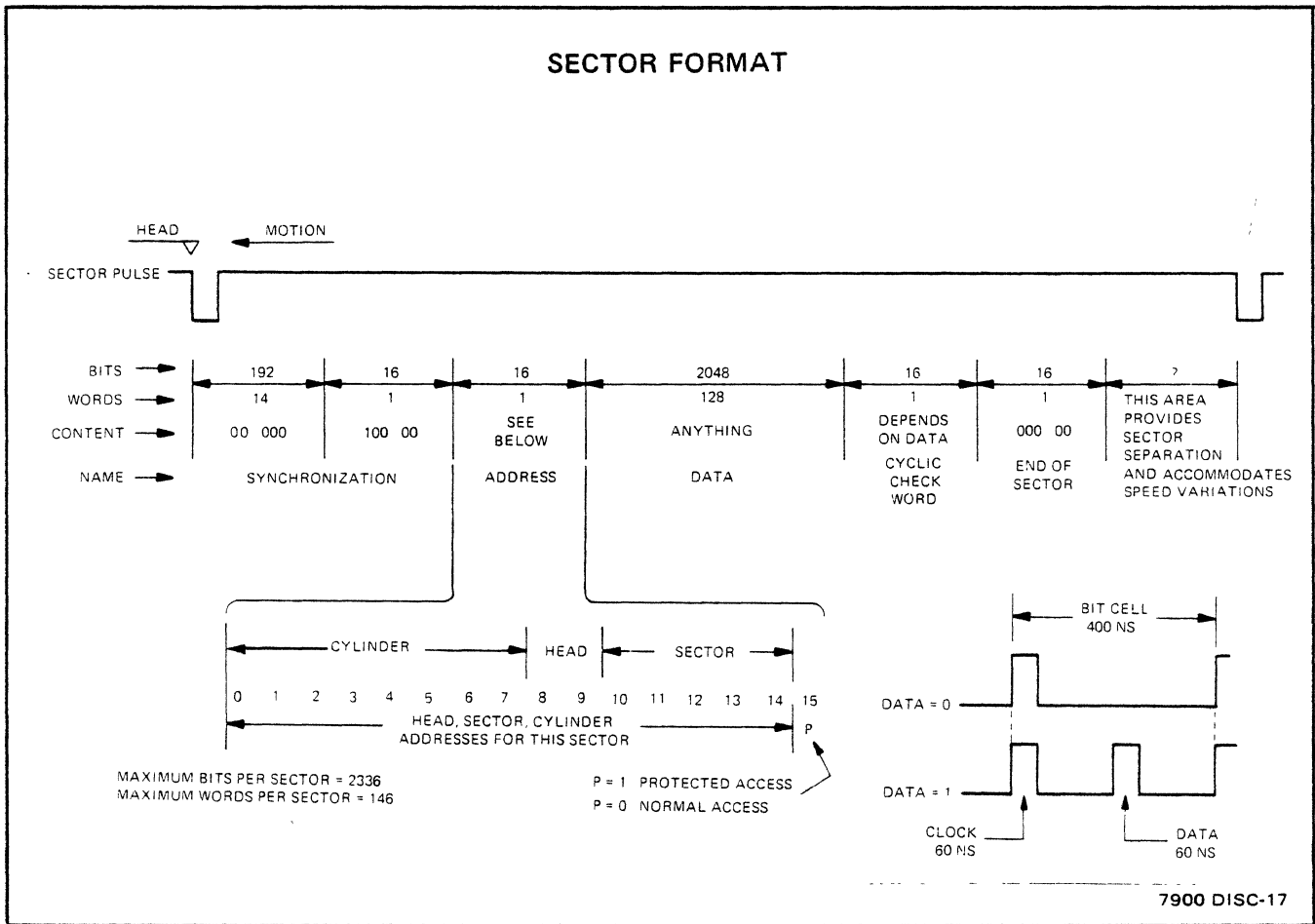

ERASE FLUX

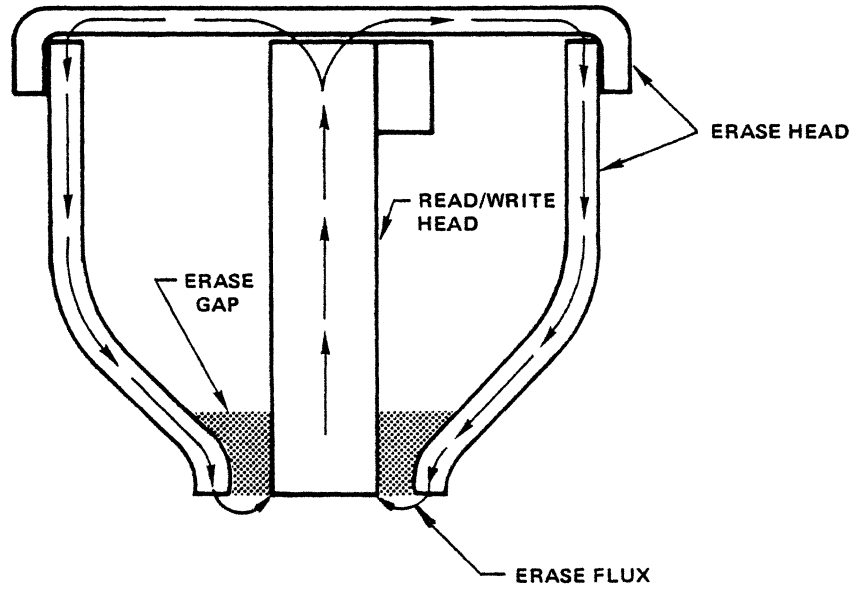

7900 DISC-24

NOTES

DRIVE ENABLED CIRCUITRY

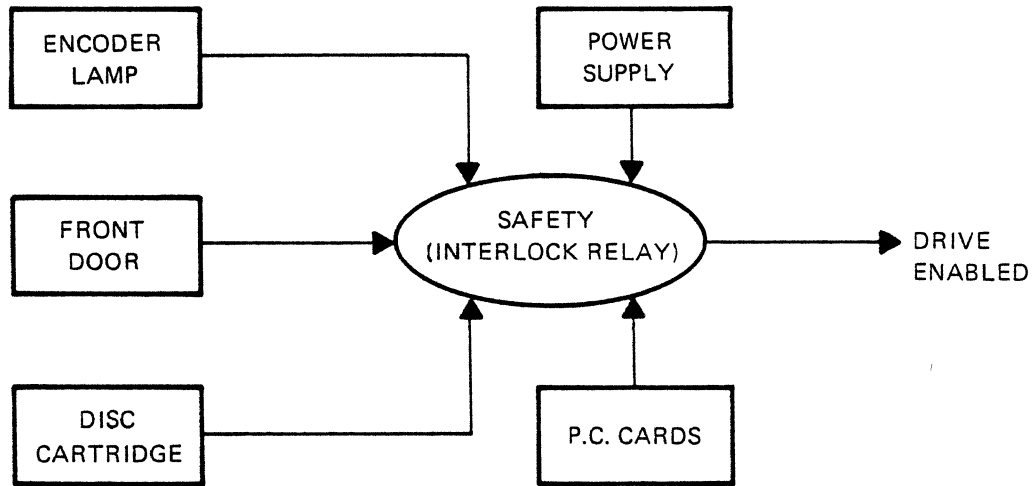

7900 DISC-33

DRIVE ENABLED CIRCUITRY

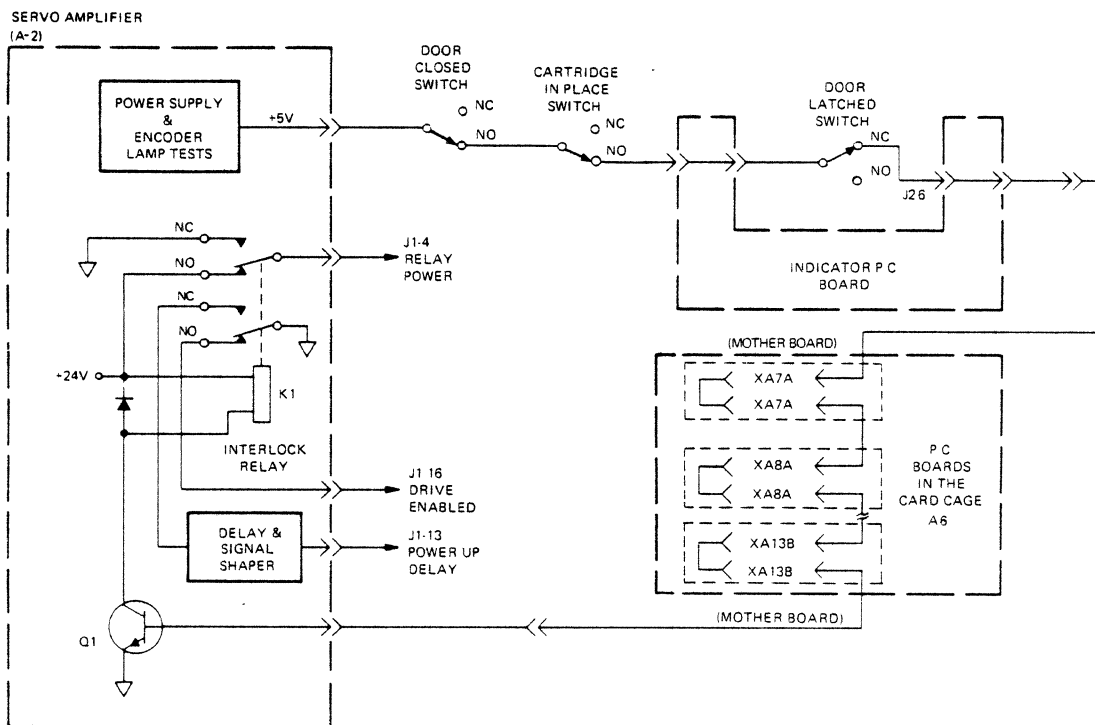

7900 DISC-34

STARTING

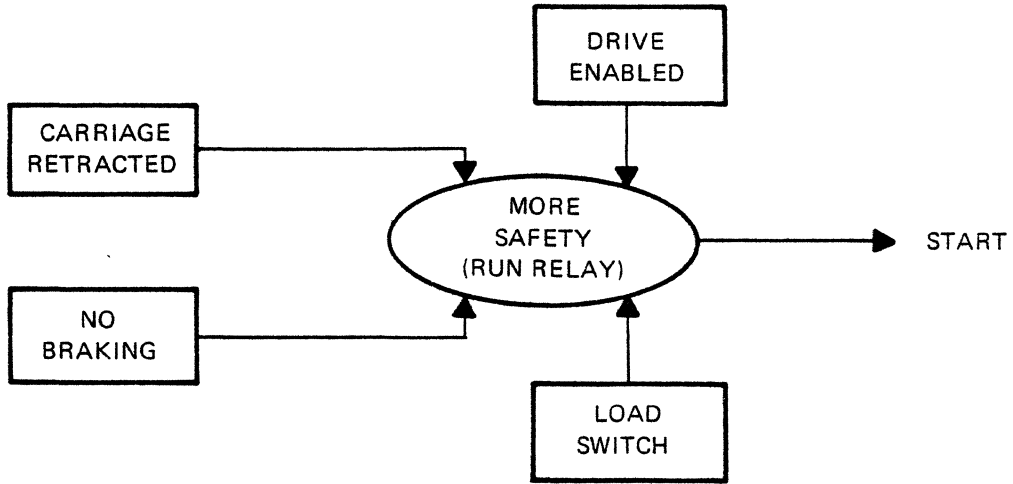

7900 DISC-35

NOTES

SPINDLE MOTOR CONTROL

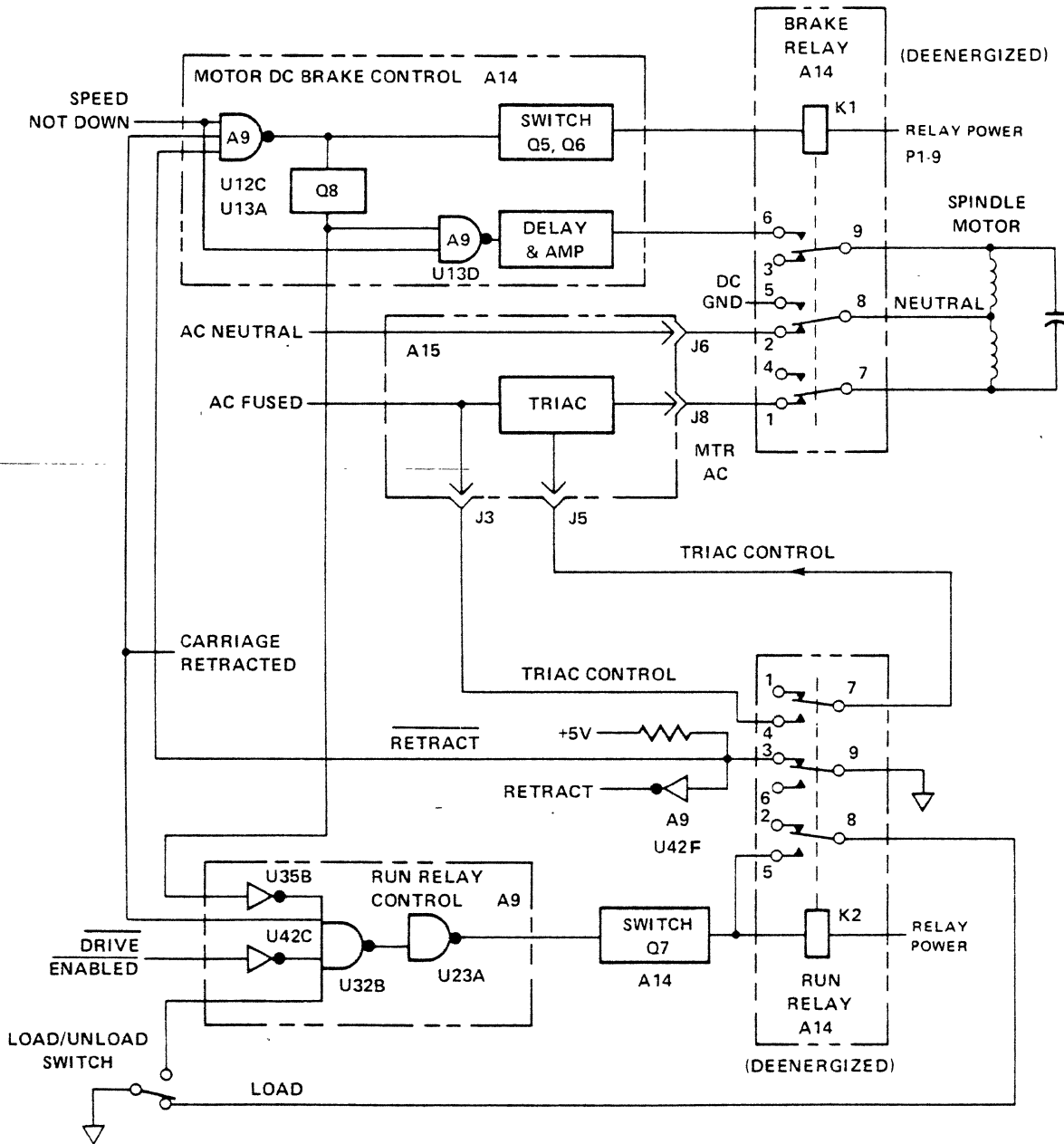

SEEK CONTROL

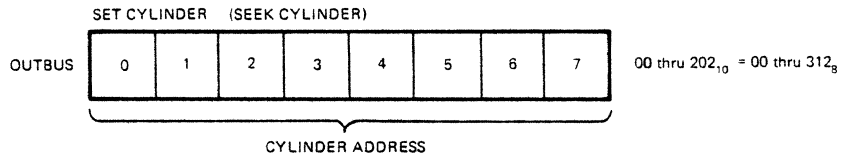
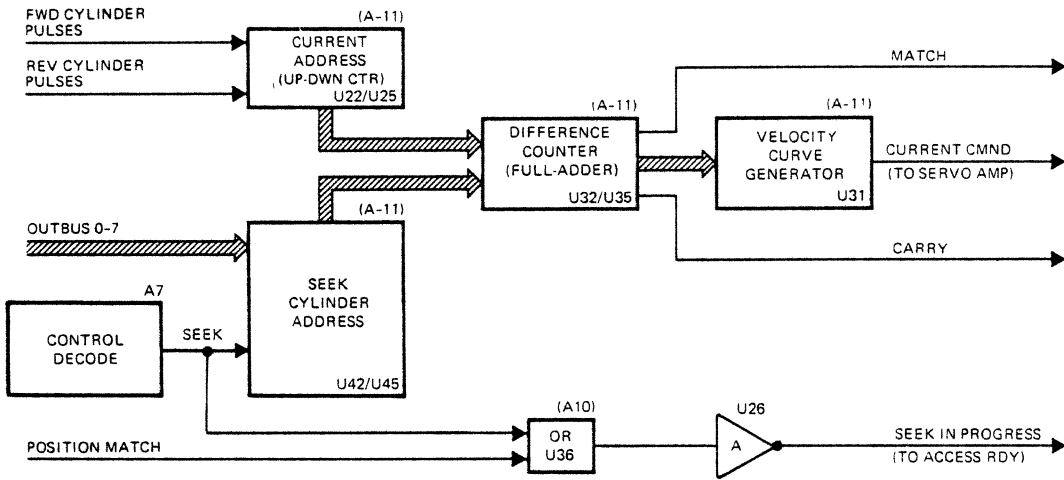

7900 DISC-48

NOTES

CARRIAGE CONTROL

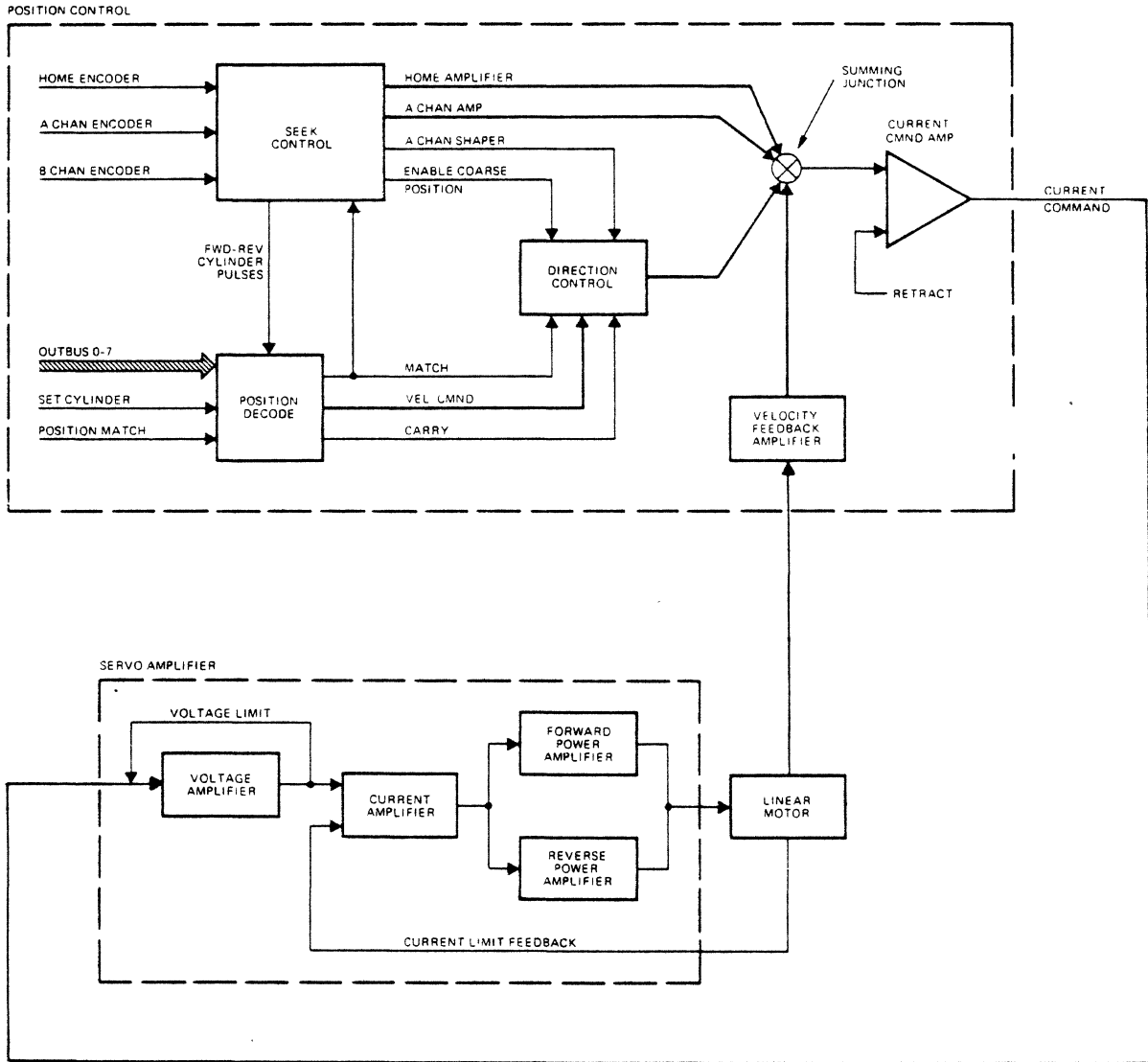

CARRIAGE DIRECTION CONTROL

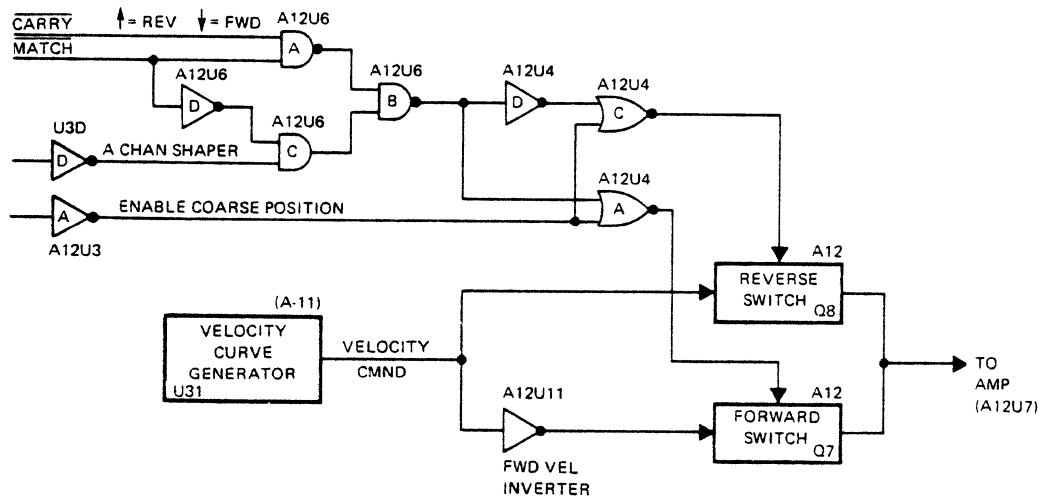

7900 DISC-52

ACTUATOR SPEED CONTROL

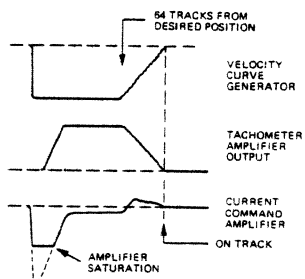
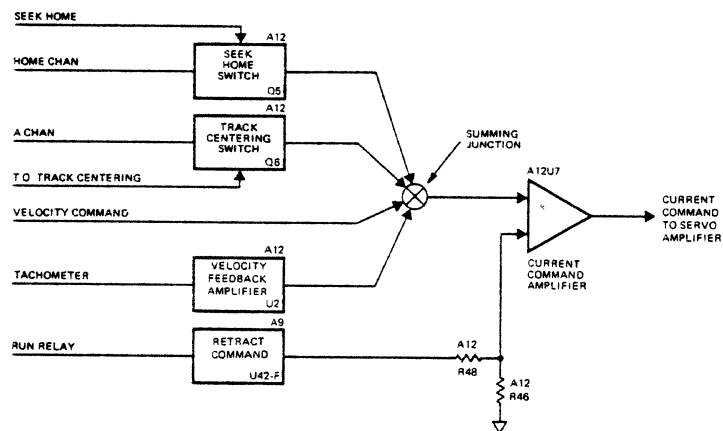

7900 DISC-53

SERVO AMPLIFIER

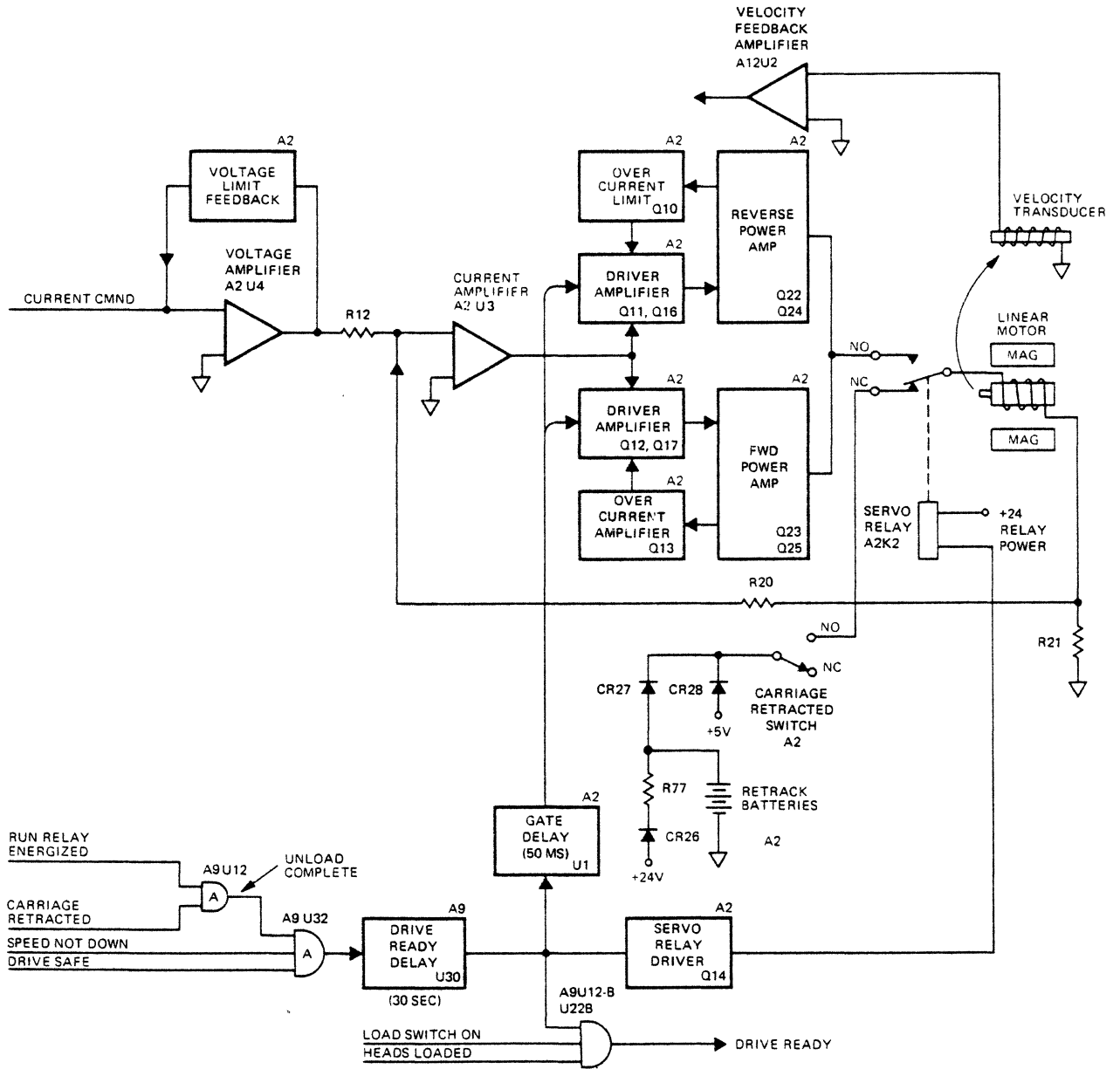

SECTOR ADDRESS COMPARISON

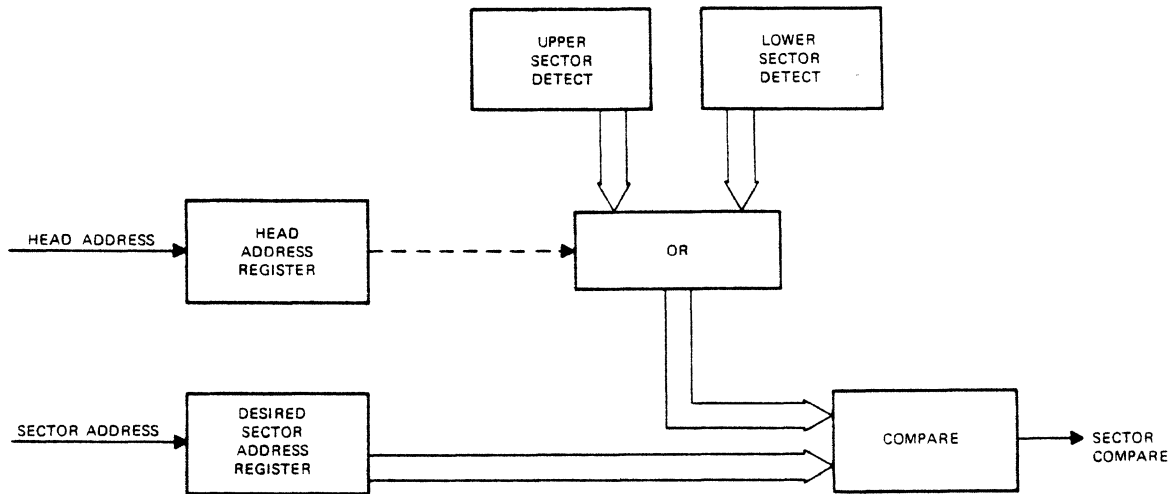

7900 DISC-57

SECTOR DETECT

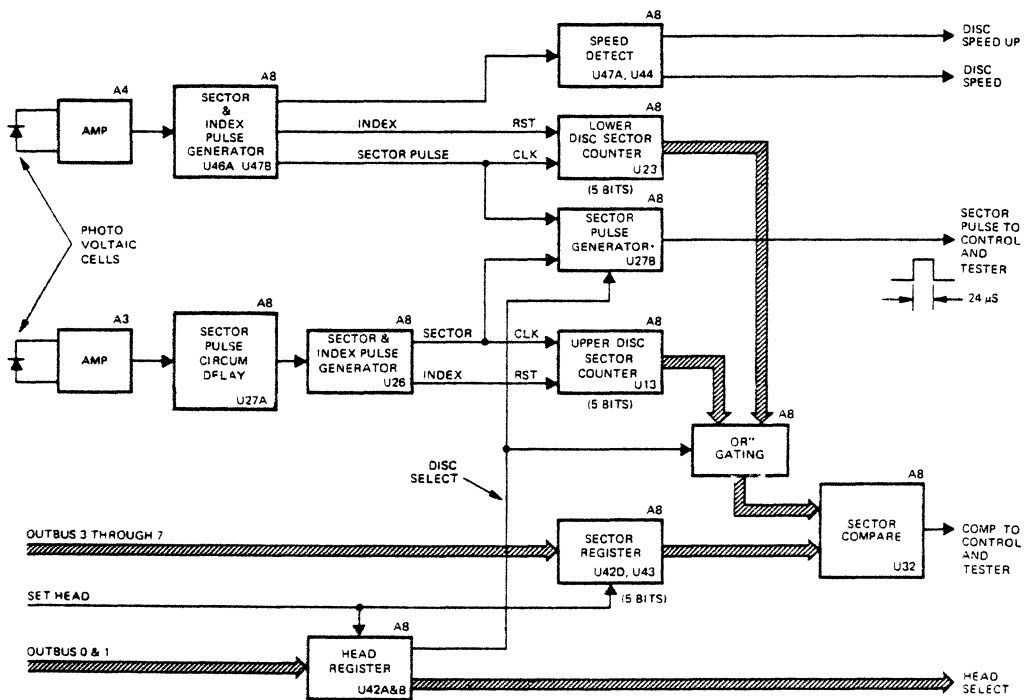

7900 DISC-58

DATA LINE DRIVERS AND RECEIVERS

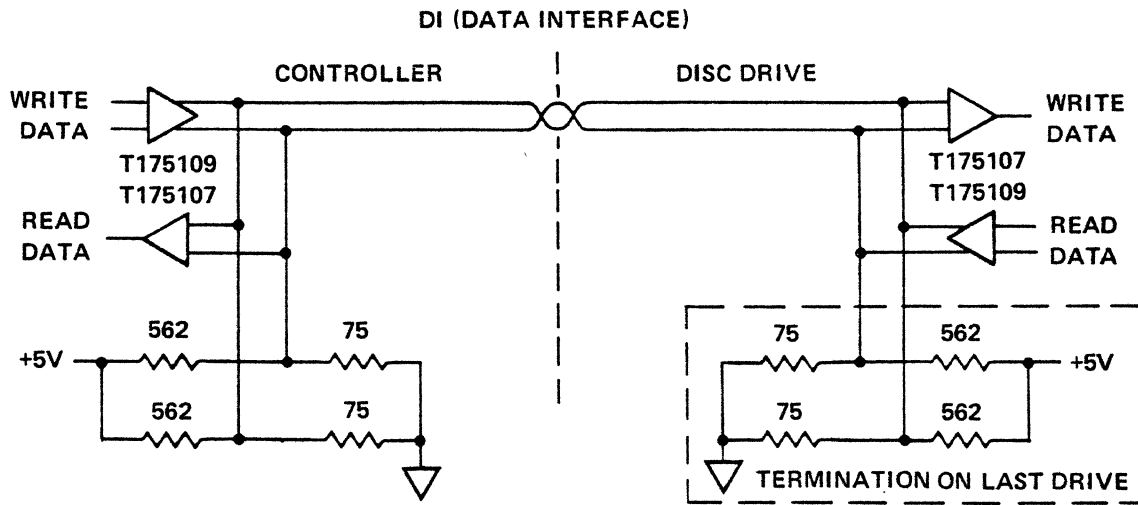

7900 DISC-61

DATA CONTROL

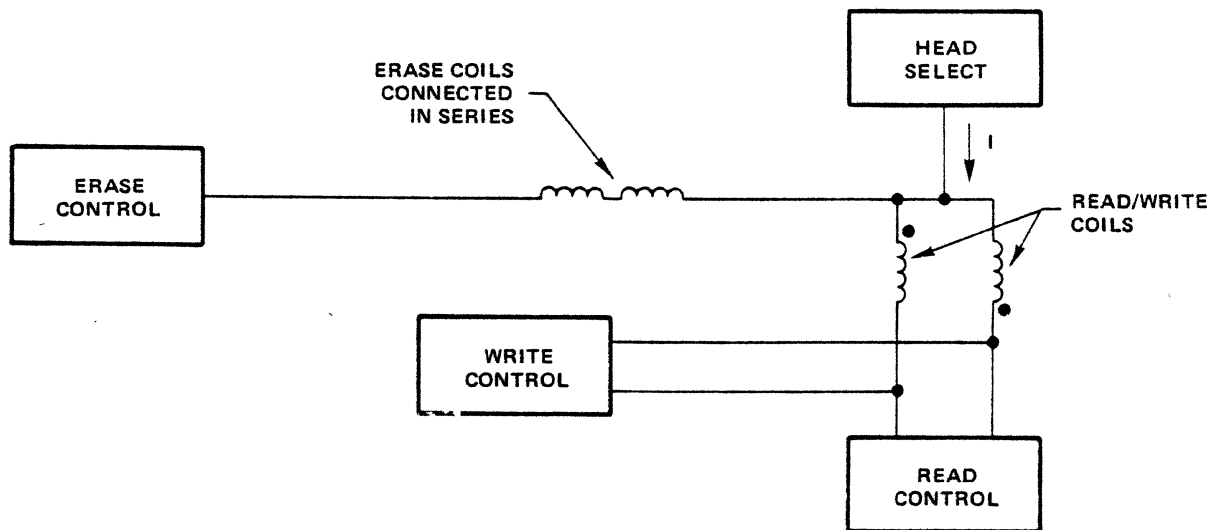

7900 DISC-62

READ CIRCUITRY

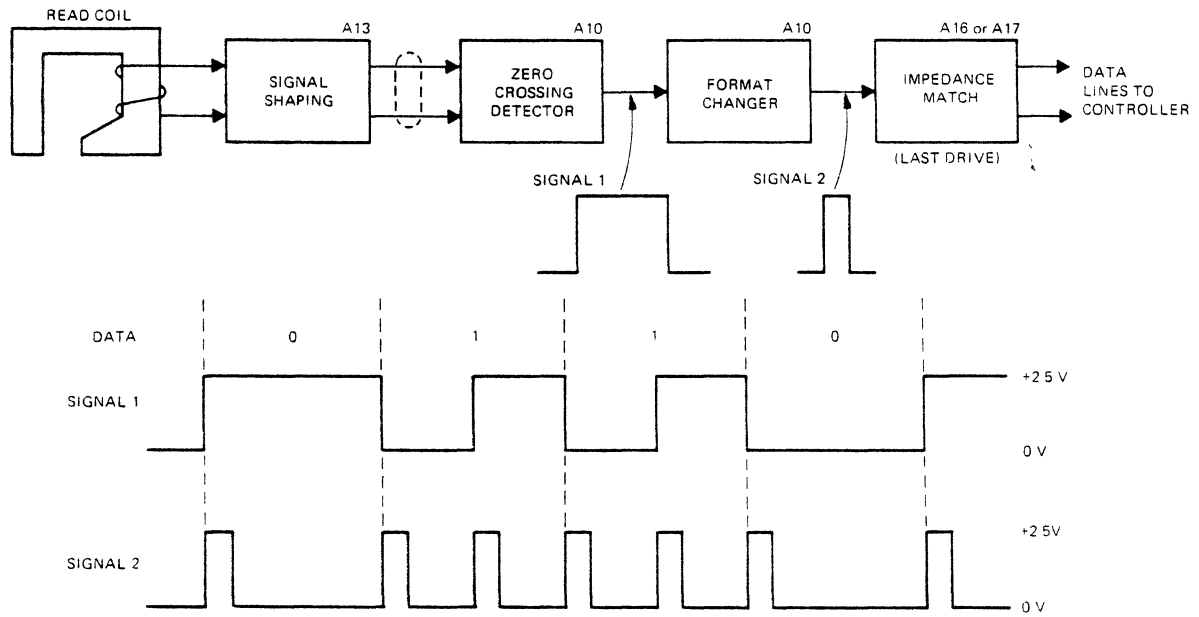

7900 DISC-63

NOTES

SIZE AND SPEED

ANGULAR VELOCITY

The disc makes 2400 revolutions per minute, 40 revolutions per second, 1 revolution per 25 milliseconds.

DIAMETERS

The diameter of track 0 is 13.14 inches.

The diameter of track 203 is 9.05 inches.

SURFACE VELOCITIES

The surface velocity at track 0 is 93.7 miles/hour.

The surface velocity at track 203 is 64.3 miles/hour.

BIT SIZES

At track 0, a bit cell is 660 microinches.

At track 203, a bit cell is 456 microinches.

Note

A bit cell during writing is 400 nanoseconds long, regardless of the track address. Also, a bit cell consists of one flux reversal for the clock and one flux reversal for the data (if data = 1). Therefore, the distance between flux reversals is one half the bit sizes shown above.

exercises/lab projects

SECT
II

SECTION III

CONTENTS

Laboratory Procedures	3-1
Exercise/Lab Project 1	3-3
Exercise/Lab Project 2	3-7
Exercise/Lab Project 3	3-11
Exercise/Lab Project 4	3-19
Exercise/Lab Project 5	3-27
Exercise/Lab Project 6	3-31
Answers To Exercise 6	3-39
Fault Isolation Reports	3-45

LABORATORY PROCEDURES

HOUSEKEEPING

Maintain good housekeeping in the lab. No food or drink will be allowed in the lab. Do not place ash trays on the machine. Books and papers placed on top of the machine or the scope will cut off the airflow and cause overheating.

When troubleshooting, always turn off power before asking instructor for another bug. Power should also be turned off before going on a break.

Start cleaning up 10 minutes before the end of the lab period. Be sure that tools, test equipment, test tapes, furniture, and machine covers are returned to their proper places. Maintain good housekeeping throughout the lab period and especially at the close of the period. The way you handle and care for tools and equipment, and the appearance of your working area, are generally indicative of the quality of your work. What kind of a job do you do?

Clean P.C. board tab contact following removal of a bug tape. Handle P.C. boards by their edges only to avoid decreasing insulation resistance.

SAFETY PRECAUTIONS

All jewelry must be removed — no watches, rings, cuff links, etc., can be worn while working on the machines. If you roll your sleeves, roll them above the elbow to prevent looseness at the roll.

Know the location and type of fire extinguishers. Learn the operation and location of machine emergency power-off switches and circuit breakers. Scopes must be grounded at all times. Use a ground lead between the scope and machine frame in addition to the grounded power cord.

Do not replace metal covers on the machine with power on; they may short out terminals.

NOTES

Assembly and Component Locations
 HP7900A Disc Drive O&S Manual
 HP13215A Disc Power Supply O&S Manual

To familiarize the student with the HP 7900 to the extent the student can correlate the main subassemblies and components with schematic diagrams and other material presented in the course.

Instructions: With power off and the power cord unplugged from the AC source, remove the covers in the order listed below.

Note: The screws holding the covers on are of different lengths for several reasons. Carefully observe what size and type of screw is removed from each hole.

I. 13215A POWER SUPPLY

- A. Remove the top cover.
- B. Using the *13215A Disc Power Supply Operating and Service Manual (13215-90003)* refer to Figure 6-1 (page 6-3), Figure 6-2 (page 6-5) and Figure 3-1 (page 3-1) and locate the following items.

- 1. AC Power Distribution terminal board (TB1) _____
- 2. DC Power Distribution terminal board (TB2) _____
- 3. 120 Vac line fuse (F1) _____
- 4. 240 Vac line fuse (F2) _____
- 5. +5 Vdc supply fuse (F3) _____
- 6. +12 Vdc supply fuse (F4) _____
- 7. -12 Vdc supply fuse (F5) _____
- 8. +24 Vdc supply fuse (F6) _____
- 9. -24 Vdc supply fuse (F7) _____
- 10. Regulator Assembly (A1) _____
- 11. +5 V Voltage Reference Amp and Error Amp (A1U2) _____
- 12. +5 V Voltage adjust (A1R7) _____
- 13. +12 V Voltage Reference Amp and Error Amp (A1U1) _____
- 14. -12 V Voltage Error Amp (A1U3) _____
- 15. +5 V Series Regulator (A1Q6) _____

- i. S2 _____
- j. S3 _____
- k. S4 _____
- l. S5 _____
- m. S6 _____
- n. S7 _____
- o. L1 _____
- p. L2 _____
- q. L3 _____
- r. L4 _____
- s. DS1 _____
- t. C1 _____
- u. C2 _____
- v. B1 _____
- w. B2 _____
- x. F1 _____
- y. F2 _____

- _____ 3. Expose the DC Interlock Board, A18 by removing the rear cover. Compare the board with the schematic diagram (Figure 5-45 of the *7900A O&S Manual*). Replace the rear cover.
- _____ 4. Identify the upper and lower heads. To expose the lower two heads, remove the lower head access cover. Refer to index 12, Figure 6-4 (page 6-11) in the *7900A O&S Manual*.
- _____ 5. Identify the Encoder Plate (index 7) and the Position Vernier (index 18) on Figure 6-3 (page 6-8) in the *7900A O&S Manual*.
- _____ 6. Identify the Position Scale (index 25) and the Encoder Head Assembly (index 24) on Figure 6-2 (page 6-4) in the *7900A O&S Manual*.

II. 7900 CARTRIDGE DISC UNIT.

_____ A. Remove the covers as shown in the *7900A O&S Manual (7900-90002)* Figure 6-1 (page 6-2).

- 1. Remove the top cover. Do not remove the two front center screws. Watch for different size screws.
- 2. Remove the two side panels. Watch for different size screws.
- 3. Remove the bottom covers. Remove ALL screws except the ones that hold the two sections of the cover together.

_____ B. Using the *7900 O&S Manual* locate all items listed in Figure 3-1. The student should take the time to read the purpose of each item listed.

_____ C. Remove and look at the absolute filter using the procedure listed in the *7900A O&S Manual*, paragraph 5-4 steps b through h.

_____ D. Locate the following listed parts using Figures 5-11 (page 5-18) and 5-12 (page 5-19) in the *7900A O&S Manual*.

1. Remove each of the following listed boards. It is suggested that the student briefly compare the board with the respective schematic diagram in Chapter 5 of the *7900A O&S Manual*.

- a. I/O Multiplex Board (XA7) _____
- b. Sector Count and Compare Board (XA8) _____
- c. Drive Control Board (XA9) _____
- d. Read/Write Control Board (XA10) _____
- e. Cylinder Address Board (XA11) _____
- f. Encoder Board (XA12) _____

2. Using Figures 5-11 and 5-12 in the *7900A O&S Manual* locate the following items and state the name or general use of the item.

- a. A1 _____
- b. A2 _____
- c. A3 _____
- d. A4 _____
- e. A6 _____
- f. A14 _____
- g. A15 _____
- h. S1 _____

- _____ B. Set the DELAY switch to ON.
- _____ C. Rotate the ACCESS MODE switch to ONE CYLINDER INCREMENTS.
- _____ D. Press RUN to start the operation.
- _____ E. To remove the time delay between seeks, set the DELAY switch off.
- _____ F. To halt the operation, set the DRIVE OPERATION CONTROL switch to ACCESS STOP.

III. SINGLE SEEK.

- _____ A. With the disc drive loaded set the DRIVE OPERATION CONTROL switch to ALLOW ACCESS MODE.
- _____ B. Rotate the ACCESS MODE switch to SINGLE SEEK.
- _____ C. Press the RUN switch once.
Note: This step must be done to repeat single seek operations only if either the DRIVE OPERATION CONTROL or ACCESS MODE switches have been changed.
- _____ D. Set the desired cylinder address into the ADDR A switches. Legal cylinder addresses are $000_{(8)}$ through $312_{(8)}$. (Note: up = "1"; down = "0".)
- _____ E. Set the desired head and sector addresses into the ADDR B switches. Legal head address for 7900 is 0 through 3. Legal head address for 7901 is 0 and 1 only. Legal sector address is octal 00 through 27. (Note: up = "1"; down = "0".)
- _____ F. Press the SINGLE OP button three times.
- _____ G. To do a second single seek operation repeat steps D through F. If either the DRIVE OPERATION CONTROL or ACCESS MODE switches are changed between seek operations, A through F must be repeated.

IV. SEEK ALTERNATE.

- _____ A. With the disc drive loaded set the DRIVE OPERATION CONTROL switch to ALLOW ACCESS MODE.

Disc Drive Service Unit

HP13219A Disc Service Unit O&S Manual

To familiarize the student with the 13219A Disc Service Unit to the extent the student can use all functions of the unit to maintain and troubleshoot the disc unit.

I. CONNECTING THE 13219A DISC SERVICE UNIT.

- _____ A. Stop the 7900 Disc Unit if it is running.
- _____ B. Turn off all power.
- _____ C. Set the DRIVE OPERATION CONTROL switch to the ACCESS STOP position. This switch prevents accidental initiation of operations by inhibiting internal clock generation.
- _____ D. Cable the service unit to the disc drive by connecting the service unit cable W4P2 to the disc drive service connector, A6J1 at the left side of the disc drive chassis. The cable should be oriented with the "cable-end" of the cable connectors facing the front of the disc drive and service unit. Connect the other end of the cable to the service unit.
- _____ E. The disc drive must be taken off-line for servicing by removing the I/O connector cable at the back of the disc drive. If the disc drive to be tested is last in a series of parallel connected units, the termination circuit board at the back of the disc drive must be reinstalled in the last remaining disc drive in the series. If the disc drive to be tested is the only drive in the series, have the instructor remove or disable the interface cards in the computer.
- _____ F. Power on the disc unit.
- _____ G. Load the disc drive.
- _____ H. Set DRIVE SELECT switches to the binary equivalent of the address for the disc drive under test. The SELECT DRIVE READY and SELECT ACCESS READY indicators should light. Rotate the DRIVE CONDITION switch to DRIVE STATUS.

II. ONE CYLINDER INCREMENTS.

- _____ A. With the disc drive loaded, set the DRIVE OPERATION CONTROL switch to ALLOW ACCESS MODE.

VI. SINGLE CYCLE (SERVO INHIBIT).

- _____ A. The SINGLE CYCLE (SERVO INHIBIT) position of the ACCESS MODE switch works the same as the SINGLE SEEK position except the SEEK signal is never sent to the disc drive. Instead, the TEST SERVO INHIBIT signal is sent to prevent seeking.

Note: Be sure to set the ACCESS MODE switch to SINGLE CYCLE *before* pressing RUN. Set RESET DRIVE FAULT to ON.

- _____ B. The SINGLE CYCLE position of the ACCESS MODE switch also allows checking the disc drive fault circuitry and automatic head unloading. To use this feature perform the following steps.
1. Load the disc drive unit.
 2. Set the RESET DRIVE FAULT switch to the off (down) position.
 3. Perform any one of the following operations:
 - a. Toggle the DRIVE OPERATION CONTROL switch between the ACCESS STOP position and the ALLOW ACCESS MODE positions.
 - b. Rotate the ACCESS MODE switch to any of the other positions then back to the SINGLE CYCLE position.
 4. Press the RUN switch.
 5. Press SINGLE SEEK three times. The unit will fault out and unload the heads.
 6. Set RESET DRIVE FAULT to ON. Heads will load.

Note: There may be a 30 second delay before the heads load.

VII. DISCONNECTING THE DISC SERVICE UNIT.

- _____ A. Unload the disc drive.
- _____ B. Turn off the power supply and disconnect it from the AC source.
- _____ C. Uncable the service unit from the disc drive.
- _____ D. Restore the drive back to an operational condition on the system if it was connected to a system at the start of this project. Ask the instructor to restore the interface cards, if applicable.

- _____ B. Rotate the ACCESS MODE switch to SEEK ALTERNATE.
- _____ C. Set the two desired cylinder addresses into ADDR A and ADDR B switches. Legal addresses are $000_{(8)}$ through $312_{(8)}$. (Note: up = "1"; down = "0".)
- _____ D. Set the DELAY switch to ON.
- _____ E. Press RUN to start the operation.
- _____ F. To halt the seeks, set the DRIVE OPERATION CONTROL switches to ACCESS STOP.
- _____ G. To remove the time delay between seeks, set the DELAY switch to OFF.

CAUTION

Before changing cylinder addresses, set the DRIVE OPERATION CONTROL switch to the ACCESS STOP position. This will prevent spurious seek operations from damaging the drive.

V. RESTORE HOME.

- _____ A. With the disc drive loaded set the DRIVE OPERATION CONTROL switch to ALLOW ACCESS MODE.
- _____ B. Rotate the ACCESS MODE switch to either the ONE CYLINDER INCREMENTS or SINGLE SEEK position.

CAUTION

Do not hold the RESTORE HOME pushbutton down while doing one cylinder increments. Failure to heed this caution may result in damage to the drive.

- _____ C. Press RUN to start the operation.
- _____ D. Press RESTORE HOME once.

8. Compare waveforms 7, 8, and 9. At what track does clipping of the waveform occur while going forward? _____
While going reverse? _____
9. What causes the clipping in waveforms 7, 8, and 9? _____

10. What is the reason for the positive overshoot on waveform 10? _____

11. What is the reason for the oscillations at the zero voltage level of waveforms 11 and 12? _____

12. Scope A12TP4. *Gently* push the carriage forward until you feel it resist. What changes do you see in waveform 11? _____

13. *Gently* push the carriage backward until it resists. What changes do you see in the waveform 11? _____

14. Does waveform 13 change polarity or pulse width when going in reverse? _____
If yes, what changes and how much? _____

15. At what track count does clipping occur on waveform 14? _____
16. What causes the small steps in waveform 15? _____

Servo Waveforms
HP7900A Disc Drive O&S Manual

To familiarize the student with the dynamic signals of the HP 7900 Disc Drive to the extent the student can use the signals for maintenance procedures and troubleshooting.

I. SERVO WAVEFORMS.

A. Observe the following waveforms by scoping one test point and varying the track seeks. As you scope each test point, find the test point on the detailed schematic diagram in the *7900A Disc Drive O&S Manual* and associate the waveform with the circuitry and signal name. Check off each waveform as you scope it, and answer the following questions:

1. Using waveform 1, approximately how much time does it take for a one track forward seek (minus track centering time)? _____

2. What is the positive and negative peak amplitudes of waveform 1?

+ _____ , - _____ .

3. What is the voltage of the A channel (waveform 1) when the heads are centered on the track? _____

4. Why does the A channel amplifier (waveform 1) have this voltage?

(Look at waveforms 2 and 3 before doing question 5.)

5. What is the positive peak and negative peak amplitudes of waveform 4?

+ _____ , - _____ .

6. What voltage does the B channel amplifier (waveform 4) have when the heads are centered on the track? _____

7. Compare waveforms 5 and 6. Notice that a 200 track seek takes twice as long as a 64 track seek. Why doesn't it take three times as long to do a 200 track seek?

CHANNEL A: TEST POINT
 CHANNEL B: ACCESS READY (SERVICE UNIT)
 SYNC EXT: A11TP2 SET CYLINDER
 10:1 DIVIDER PROBES
 CHOPPED

**SINGLE TRACK SEEK
 ALTERNATE**

ON THE SERVICE UNIT SELECT:
 DRIVE STATUS
 RESET DRIVE FAULT
 ALLOW ACCESS MODE
 SEEK ALTERNATE
 DELAY ON

PRESS:

RUN

A12TP2
 VELOCITY TRANSDUCER

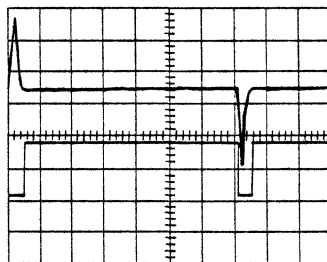

⑦ 1V/CM, 10MSEC/CM

A12TP4
 CURRENT COMMAND

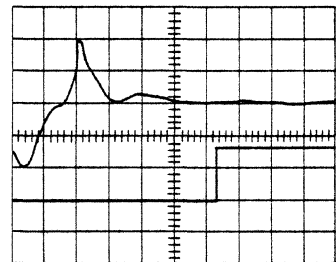

⑩ .5V/CM, 1MSEC/CM

**64 TRACK SEEK
 GOING FORWARD**

ON THE SERVICE UNIT SELECT:
 DRIVE STATUS
 RESET DRIVE FAULT
 ALLOW ACCESS MODE
 SEEK ALTERNATE
 DELAY ON
 ADDR A = 64

PRESS:

RUN

A12TP2
 VELOCITY TRANSDUCER

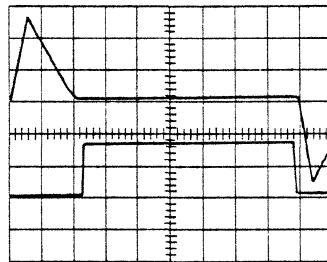

⑧ 2V/CM, 10MSEC/CM

A12TP4
 CURRENT COMMAND

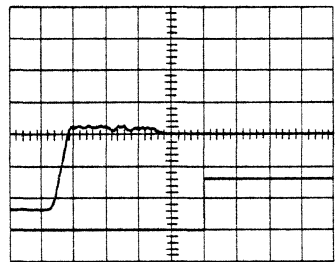

⑪ 5V/CM, 5MSEC/CM

**200 TRACK SEEK
 ALTERNATE**

ON THE SERVICE UNIT SELECT:
 DRIVE STATUS
 RESET DRIVE FAULT
 ALLOW ACCESS MODE
 SEEK ALTERNATE
 DELAY ON
 ADDR A = 200

PRESS:

RUN

A12TP2
 VELOCITY TRANSDUCER

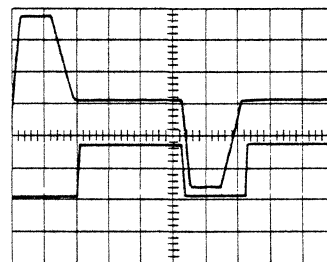

⑨ 2V/CM, 20MSEC/CM

A12TP4
 CURRENT COMMAND

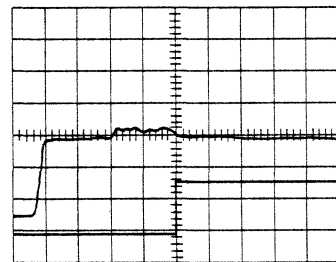

⑫ 5V/CM, 10MSEC/CM

CHANNEL A: TEST POINT
 CHANNEL B: ACCESS READY (SERVICE UNIT)
 SYNC EXT: A11TP2 SET CYLINDER
 10:1 DIVIDER PROBES
 CHOPPED

**SINGLE TRACK SEEK
 GOING FORWARD**

ON THE SERVICE UNIT SELECT:
 DRIVE STATUS
 RESET DRIVE FAULT
 ALLOW ACCESS MODE
 ONE CYLINDER INCREMENTS
 DELAY ON

PRESS:
 RUN

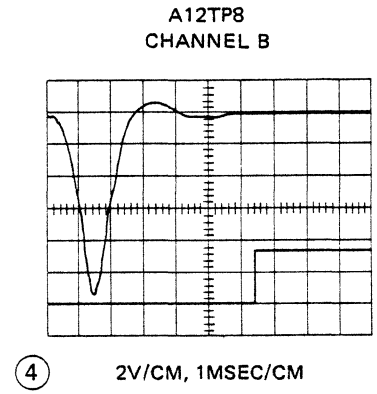
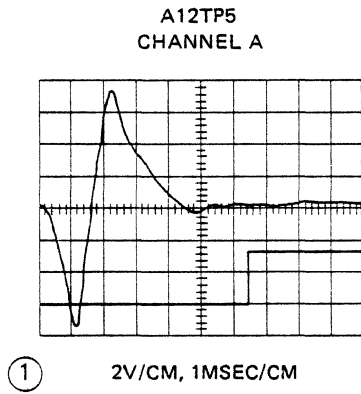

**64 TRACK SEEK
 ALTERNATE**

ON THE SERVICE UNIT SELECT:
 DRIVE STATUS
 RESET DRIVE FAULT
 ALLOW ACCESS MODE
 SEEK ALTERNATE
 DELAY ON
 ADDR A = 64

PRESS:
 RUN

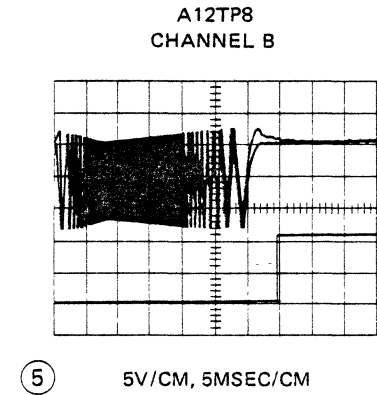
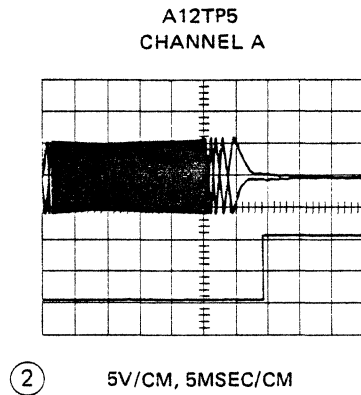

**200 TRACK SEEK
 ALTERNATE**

ON THE SERVICE UNIT SELECT:
 DRIVE STATUS
 RESET DRIVE FAULT
 ALLOW ACCESS MODE
 SEEK ALTERNATE
 DELAY ON
 ADDR A = 200

PRESS:
 RUN

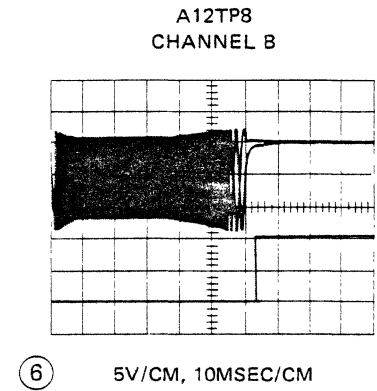
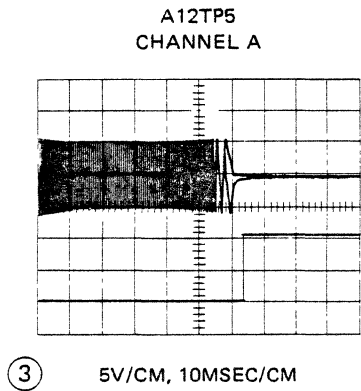

B. Scope the signals specified below and answer the questions about each signal.

1. Set the scope to 2MSEC/CM and do *ONE CYLINDER INCREMENTS* with DELAY on. Scope the following test points and record the amplitude of each signal.

<u>Carriage Movement</u>	<u>(2V/CM) A2TP3</u>	<u>(.5V/CM) A2TP4</u>
Forward	_____ V+	_____ V+
Forward	_____ V-	_____ V-
Reverse	_____ V+	_____ V+
Reverse	_____ V-	_____ V-

2. With the oscilloscope at 5V/CM and 10MSEC/CM do 310₍₈₎ track seeks with DELAY off. Scope the following testpoints and record the amplitude of each signal.

<u>Carriage Movement</u>	<u>A2TP3</u>	<u>A2TP4</u>
Forward	_____ V+	_____ V+
Forward	_____ V-	_____ V-
Reverse	_____ V+	_____ V+
Reverse	_____ V-	_____ V-

CHANNEL A: TEST POINT
 CHANNEL B: ACCESS READY (SERVICE UNIT)
 SYNC EXT: A11TP2 SET CYLINDER
 10:1 DIVIDER PROBES
 CHOPPED

**SINGLE TRACK SEEK
 GOING FORWARD**

ON THE SERVICE UNIT SELECT:
 DRIVE STATUS
 RESET DRIVE FAULT
 ALLOW ACCESS MODE
 ONE CYLINDER INCREMENTS
 DELAY ON

PRESS:
 RUN

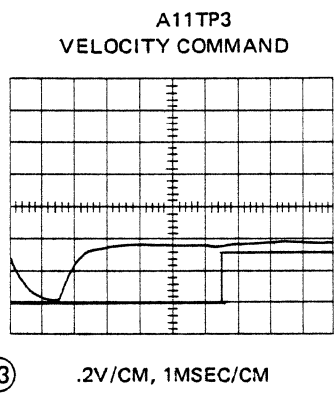

**64 TRACK SEEK
 ALTERNATE**

ON THE SERVICE UNIT SELECT:
 DRIVE STATUS
 RESET DRIVE FAULT
 ALLOW ACCESS MODE
 SEEK ALTERNATE
 DELAY ON
 ADDR A = 64

PRESS:
 RUN

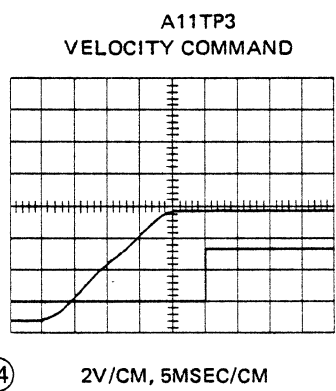

**200 TRACK SEEK
 ALTERNATE**

ON THE SERVICE UNIT SELECT:
 DRIVE STATUS
 RESET DRIVE FAULT
 ALLOW ACCESS MODE
 SEEK ALTERNATE
 DELAY ON
 ADDR A = 200

PRESS:
 RUN

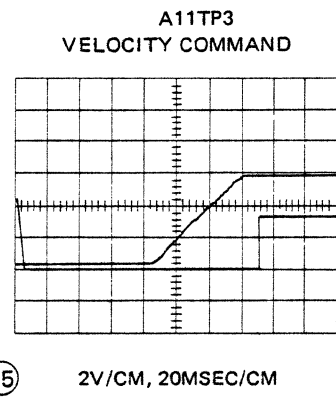

III. SECTOR ADDRESSING WAVEFORMS.

- A. Measure the output of the upper sector transducer at A3 J3.
1. With light from DS1 _____ V.
 2. Light blocked from DS1 _____ V.
- B. Set the scope to 2V/CM and 10 μ SEC/CM. Use channel B to scope SECTOR PULSE at A8 TP5. Sync INT on channel B. Record the pulse width. _____ μ S.
- C. Set the scope to 2V/CM and 20 μ SEC/CM. Use channel A to scope INDEX at A8 TP3. Sync INT – on channel A. Record the pulse width. _____ μ S.
- D. Set the scope to 2V/CM and 2MSEC/CM.
1. Turn the horizontal sweep Vernier toward UNCALIBRATED until two INDEX pulses appear on the screen.
 2. Observe channel B and record the number of sector pulses that occur between the *index* pulses. _____.
- E. Set the scope to 2V/CM and 5MS/CM. Use channel A to scope INDEX at A8 TP3. Sync _____ INT – on channel A.
1. Use channel B to scope SECTOR COMPARE on the DDSU.
 2. While doing single seeks, select the following sector addresses and measure the delay time between INDEX and SECTOR COMPARE. Press SINGLE OP. Record the delay times below.

SECTOR ADDRESS	DELAY TIME
0	_____ MS
1	_____ MS
11 ₍₈₎	_____ MS
23 ₍₈₎	_____ MS

II. SEEK WAVEFORMS.

- A. Set the scope to .2V/CM, 1MSEC/CM, and CHOPPED. Sync INT and scope A11 TP2 while doing one cylinder increments with DELAY off. What is the pulse width of the SEEK signal at this point ____ μ SEC.
- B. Sync on A8 TP3 (INDEX). Set the scope for .5V/CM and scope A12 TP3.
1. Restore the carriage to home (cylinder zero) position. What is the voltage at A12 TP3?
_____V
 2. Do a single seek operation to cylinder 1.
 1. What is the voltage at A12 TP3? _____V
 3. Do a single seek operation to cylinder 2.
 2. What is the voltage at A12 TP3? _____V
If the carriage is moved to cylinder 3, do you think the voltage will increase any more? _____
 4. Do a single seek operation to cylinder 3.
 3. Did the voltage increase? _____
To what new value, if yes? _____
- C. Set the scope to 5MSEC/CM and .5V/CM. Scope A12 TP3 with A channel and A12 TP6 with B channel.
1. Initiate a delayed seek alternate operation alternating between home and cylinder 4. As a result of looking at these signals, what do you think the main purpose of the Home Detector/Schmitt Trigger is? _____
- D. Set the scope to 1MSEC/CM and 5V/CM. Sync INT. With the A channel scope A12 TP5. With the A channel scope A12 TP5. With the B channel scope A12 TP8. Do one cylinder increments with the delay off.
1. When the disc unit is seeking forward, which pulse leads by 90 degrees? _____
 2. When the disc unit is seeking reverse, which pulse leads by 90 degrees? _____

I. ENCODER CLEARANCE ADJUSTMENT (Continued)

- D. Turn on the disc power supply and set the disc drive LOAD/UNLOAD switch to LOAD.
- E. Wait for the spindle to reach maximum speed (about 30 seconds).
- F. Manually extend the carriage and ensure that the clearance between the encoder plate and the reticle is between 0.005 and 0.008 inch at both ends of travel. If this is not met, the encoder mounting screws must be loosened and encoder housing moved. Loosen the encoder mounting screws for the encoder base assembly to adjust the encoder plate to the left or right.

CAUTION

When checking or adjusting the encoder clearance, use non-metallic feeler gauge to avoid scratching the encoder glass.

- G. Perform the Encoder Parallelism Adjustment procedure starting with step "D."

II. ENCODER PARALLELISM ADJUSTMENT.

- A. Disable cartridge-in-place interlock switch S5 and door closed switch S6.
- B. Place folded Kimwipe between the upper heads.
- C. Disable the linear motor by removing connector A2P5 on the servo amplifier assembly.
- D. Scope the (A channel) amplifier output on the encoder assembly, A12TP5.

CAUTION

To prevent the lower heads from contacting and damaging the disc surface, speed must always be up while the carriage is extended.

- E. Loosen the encoder locking screw (Allen head).
- F. Turn on the disc power supply and set the disc drive LOAD/UNLOAD switch to LOAD.
- G. Wait for the spindle motor to reach maximum speed (about 30 seconds).
- H. Manually exercise the carriage and adjust the encoder parallelism adjusting screw for maximum peak-to-peak amplitude.
- I. Observe the shape of the waveform. The waveform should be almost triangular with little rounding of the peak, as shown in Figure 1.

Note: At this point, the reticle mask marks are parallel to the encoder cylinder marks.

Alignment and Adjustments
 HP7900A Disc Drive O&S Manual
 HP13219A Disc Service Unit O&S Manual

To familiarize the student with the HP 7900 adjustment and alignment procedures to the extent the student can adequately use the procedures to maintain and troubleshoot the disc drive.

INSTRUCTIONS.

Before doing the adjustments and alignments, set the LOAD/UNLOAD switch to UNLOAD. Remove the disc cartridge. Set the disc power supply POWER switch to OFF. Remove the disc drive top cover and cartridge receiver. The following alignments and adjustments should be done in the order presented in this project. Sign off each step as you complete it.

COMPLETED	PARAGRAPH	ADJUSTMENT
_____	I	Encoder Clearance Adjustment
_____	II	Encoder Parallelism Adjustment
_____	III	Encoder Alignment
_____	IV	Head Alignment
_____	V	Sector Circumferential Adjustment
_____	VI	Seek Time Adjustment

I. ENCODER CLEARANCE ADJUSTMENT.

To adjust the encoder clearance, proceed as follows:

- A. Disable disc drive cartridge-in-place switch S5 and door closed switch S6.
- B. Place a folded Kimwipe between the upper heads.
- C. Disable the linear motor by removing connector A2P5 on the servo amplifier assembly.

CAUTION

To prevent the lower heads from contacting and damaging the disc surface, the disc drive speed must always be up while the carriage is extended.

III. ENCODER ALIGNMENT (continued)

- B. Turn on disc power supply and set the LOAD/UNLOAD switch to LOAD.
- C. Wait for spindle to reach maximum speed.
- D. Scope the encoder assembly channel A amplifier output, A12TP5.
- E. Manually move the carriage back and forth while making the following adjustments:
 1. Adjust the A GAIN ADJ variable resistor on encoder assembly A12 for $12 \pm 0.5V$ peak-to-peak output. (See Figure 2.)
 2. Adjust the A BAL ADJ variable resistor on encoder assembly A12 for an equal swing (± 0.5 volts) above and below 0 volts. (See Figure 2.)

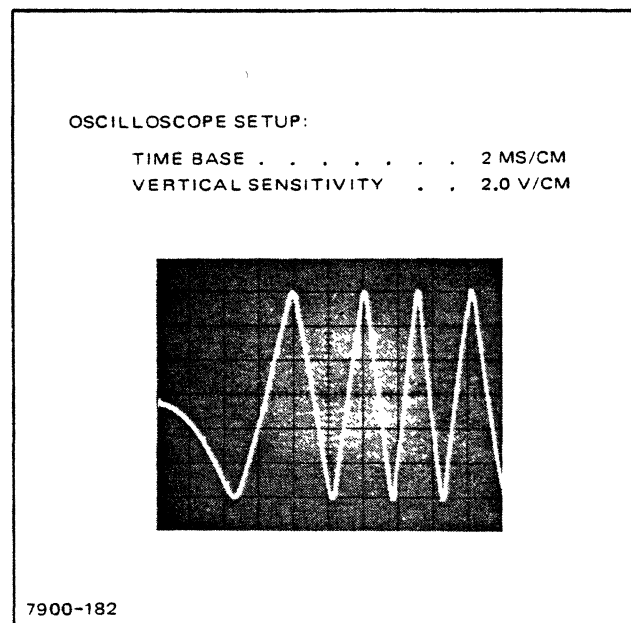

Figure 2. Encoder Alignment Waveform

IV. HEAD ALIGNMENT.

To align the disc drive heads, proceed as follows:

- A. Turn on the disc power supply and set up disc protect switch S3 so that the U/D lamp lights.
- B. Install the alignment disc cartridge (part no. 1535-0066).
- C. Set the LOAD/UNLOAD switch to LOAD.
- D. Alternately seek between cylinders 000 and 128. Set the DELAY switch to ON.
- E. Allow the disc drive to operate for approximately 25 minutes to stabilize disc drive temperature. The top cover of the disc drive must be on during this time.
- F. Position the carriage to cylinder 100 and select head 0.
- G. Scope A13 TP2.
- H. Sync on INDEX, A8 TP2.
- I. Set the RESET DRIVE FAULT switch to ON.
- J. Loosen the locking screws holding the head in place.
- K. Using the head adjusting tool, position the head to minimize amplitude modulation of the output signal. (See waveforms in Figure 3.)

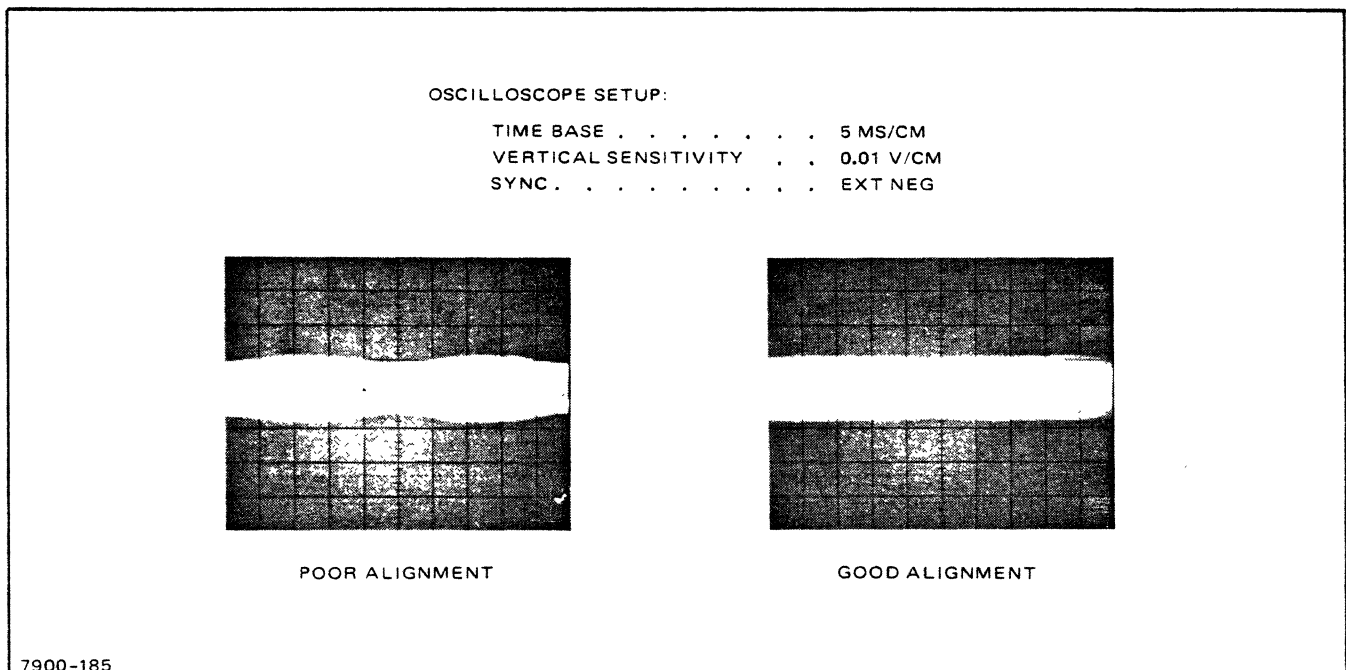

Figure 3. Head Alignment Waveforms

III. ENCODER ALIGNMENT. (continued)

- F. Set the C BAL ADJ variable resistor on encoder assembly A12 at midrange.
- G. Set the VEL COM variable resistor on cylinder address assembly A11 fully counterclockwise; then advance it 1/4 turn clockwise.
- H. Retract the carriage, set LOAD/UNLOAD switch to UNLOAD, and remove disc drive power.
- I. Connect the disc service unit. (Refer to *Disc Service Unit O&S Manual*.)
- J. Reconnect COIL lead A2P5.
- K. Move servo amplifier power connector A2P6 to the TEST position (A2 J7).

Note: Current is limited to the linear motor while in the TEST position, preventing possible damage to the motor during adjustments.

- L. Remove the carriage detent.
- M. Restore disc drive power.
- N. Set the RESET DRIVE FAULT switch to ON. Set the LOAD/UNLOAD switch to LOAD.
Note: After 30 seconds, the carriage will extend to the HOME position (cylinder 000).
- O. Scope the channel C amplifier output, A12TP3. Set the scope to 10MS/CM and .01V/CM.
- P. Adjust the C BAL ADJ variable resistor to obtain an oscilloscope deflection of 0.0 ± 0.1 volts.
- Q. Do one-cylinder increment seeks to ensure that the cylinder addressing circuitry is functional.
- R. Set the LOAD/UNLOAD switch to UNLOAD and remove disc drive power.
- S. Reconnect A2P6 to the operate position. Remove the Kimwipe from between the upper heads.
- T. Install the carriage detent, cartridge receiver, and a "scratch" disc cartridge.
- U. Restore disc drive power and set LOAD/UNLOAD switch to LOAD.
- V. Program the disc service unit to alternately seek between cylinder 000 and 202.
- W. Scope the ACCESS READY test point on the disc service unit.
- X. Adjust the VEL CMND variable resistor on cylinder address assembly A11, such that the "not" Access Ready signal is low (0 volts) for 53 ± 2 milliseconds.
- Y. Set the DRIVE OPERATION CONTROL on the disc service unit to ACCESS STOP.
- Z. Set the LOAD/UNLOAD switch to UNLOAD and remove drive power.

V. SECTOR CIRCUMFERENTIAL. (continued)

- F. Observe the waveform in Figure 4 and ensure that the first data pulse is present within ± 6 microseconds of the data pulse in step "D".

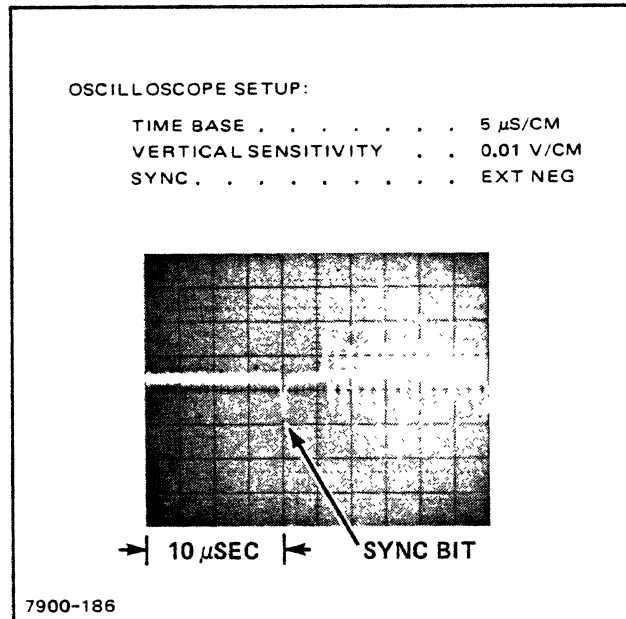

Figure 4. Data Pulses

Note: If the above requirement is not met, ensure that the heads are properly seated in the carriage assembly.

- G. Adjust the sector position variable resistor until the data pulse is half way between its present position and the 20 microsecond position. This assures equal displacement of the data pulses for heads 0 and 1 in relation to the 20 microsecond position (i.e. both data pulses should now be within 3 microseconds of the 20 microsecond position).
- H. Remove any alignment tools and restore disc drive for operation.

IV. HEAD ALIGNMENT. (continued)

- L. Tighten the locking screw and ensure that the adjustment has not changed.
- M. Seek to cylinder 95 and ensure that the circumferential adjustment waveform is present.

Note: If the waveform is not present, it is possible that the head was aligned to cylinder 105 instead of cylinder 100.

- N. Using the disc service unit, select head 1.
- O. Repeat steps IV.F through M for head 1.

SECTOR CIRCUMFERENTIAL

To adjust for minimum sector circumferential seek (or skew) proceed as follows:

- A. Using the disc service unit, position the carriage at cylinder 95 and select head 0.
- B. Scope A13TP2.
- C. Connect the SYNC probe to upper disc index test point A8TP4.
- D. Adjust the sector position variable resistor (A8R2) so that the first data pulse is 20 microseconds from the leading edge of the index pulse (beginning of sweep) as shown in Figure 4.
- E. Select head 1.

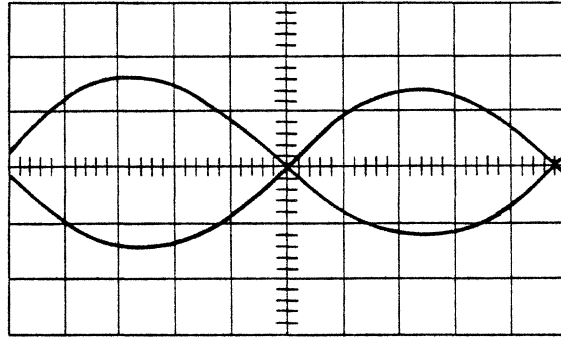

CORRECT ALIGNMENT

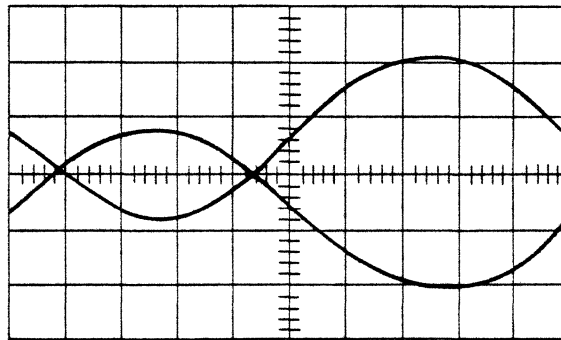

**POOR ALIGNMENT
HEADS TOO FAR FORWARD**

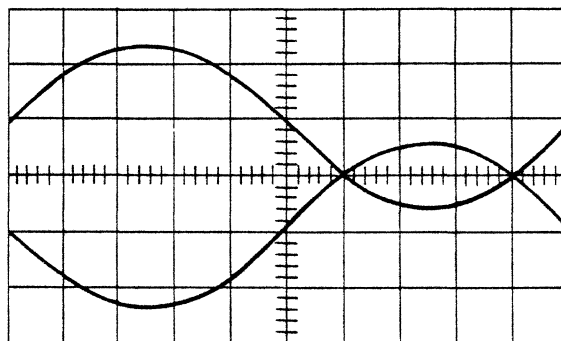

HEADS ADJUSTED TOO FAR REVERSE

Figure 1. Head Alignment Waveforms

Catseve Pattern Alignment Procedure
SN 7900A-15A

The student will use the MDS certification pack and the following procedure to determine if a head is correctly aligned. He will recognize the pattern associated with an incorrectly aligned head and make the appropriate adjustments.

A. HEAD ALIGNMENT.

To align the disc drive heads using the MDS certification pack, perform the following steps:

1. Turn on the disc power supply and set upper disc protect switch S3 to DATA PROTECT U/D.
2. Install the alignment disc cartridge (part no. 1535-2531).
3. Set the LOAD/UNLOAD switch to LOAD.
4. On the disc service unit, set the RESET DRIVE FAULT switch to ON.
5. Set the disc service unit to do ALTERNATE SEEKS between cylinders 000 and 128. Set DELAY to ON.
6. Allow 25 minutes for the disc drive temperature to stabilize. The disc cover must be on during this time.
7. Seek to cylinder 100 ($144_{(8)}$) and select head 0.
8. Set the scope for 2MSEC/CM and .05V/CM. Scope the read/write preamplifier A13TP2.
9. Use the B channel to scope A8TP4.
10. Set the B channel to 2V/CM, CHOPPED.
11. Sync INT – on the upper INDEX PULSE, A8TP4.
12. Uncalibrate the horizontal sweep until two index pulses can be seen; one at the first mark and one at the last mark of graticule. (See Figure 1.)

B. Sector Circumferential Adjustment (continued)

6. Select head 1.

7. Ensure that the first data pulse is within 20 ± 6 microseconds of the index pulse.

Note: If the above requirements are not met, ensure that the heads are properly seated in the carriage assembly. If heads are seated properly and alignment cannot be accomplished within specs, replace the head that is out of tolerance.

8. Adjust the sector position variable resistor (A8R1) so that 20 microseconds of delay occurs midway between the pulse positions observed in steps 5 and 7.

9. Remove any alignment tools and restore the disc drive back to operation.

13. Loosen the locking screw holding the head in place.
14. Using the head adjusting tool, position the head until the crossover point is exactly in the center of the scale. (See Figure 1.)
15. Tighten the locking screw and ensure that the adjustment has not changed.
16. Perform steps 7 through 15 for head 1.

B. Sector Circumferential Adjustment.

To adjust for minimum sector circumferential, perform the following steps:

1. Using the disc service unit, position the carriage at cylinder 95 and select head 0.
2. Set the A channel for .05V/CM and $5\mu\text{S}/\text{CM}$. Scope the read/write preamplifier A13TP2.
3. Set the B channel to 2V/CM and ALTERNATE. Scope A8TP4.
4. Sync INT – on the upper INDEX PULSE, A8TP4.
5. Adjust the sector position variable resistor (A8R2) for a 20-microsecond delay from the INDEX PULSE (beginning of sweep) to the start of the first data pulse. (See Figure 2.)

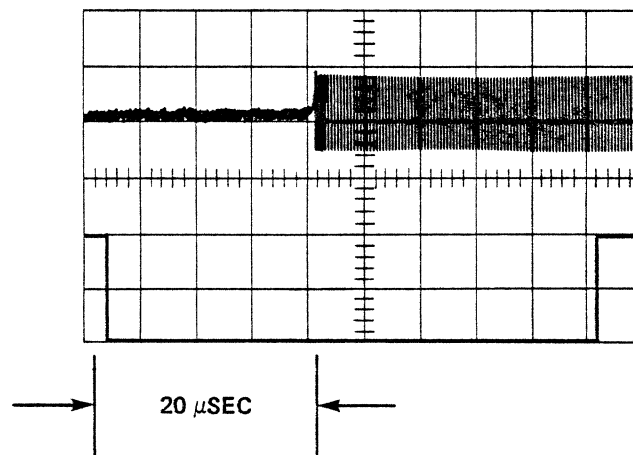

Figure 2. Circumferential Waveform

4. What is the one operation that can be done with the 7900 Disc Drive which does not require a logical drive address to be sent to the drive?

5. Why are the three signals SET CYLINDER, SET HEAD & SECTOR, and CONTROL sent to the Disc Drive when information is sent over the outbus lines?

6. Fill in the following tables of legal addresses:

A. HP 7900

1. Cylinder Address:

a. _____ (10) through _____ (10)

b. _____ (8) through _____ (8)

2. Sector Address:

a. _____ (10) through _____ (10)

b. _____ (8) through _____ (8)

3. Head Address: _____ through _____

B. HP 7901

1. Cylinder Address:

a. _____ (10) through _____ (10)

b. _____ (8) through _____ (8)

2. Sector Address:

a. _____ (10) through _____ (10)

b. _____ (8) through _____ (8)

3. Head Address: _____ through _____

7. What is the primary difference between the status information that is gated into the controller via the inbus lines and the status sent to the controller when that drive is selected?

7900 Level 1 Questions

7900 Operation & Service Manual

13215 Operation & Service Manual

To provide the student with a set of questions which will help the student review the material presented in class.

1. The 13215 Power Supply provides the following voltages:

- A. _____ VDC adjustable, regulated.
- B. _____ VDC regulated.
- C. _____ VDC regulated.
- D. _____ VDC $\pm 10\%$ unregulated.
- E. _____ VDC $\pm 10\%$ unregulated.

2. Match the following board designations (which are not plugged onto the motherboard) with their names.

- | | |
|-----|--------------------------|
| A1 | Servo Amp Assembly |
| A2 | Motherboard Assembly |
| A3 | DC Brake Assembly |
| A4 | Board Does Not Exist |
| A5 | Indicator Assembly |
| A6 | Lower Sector Transducer |
| A14 | Motor Control Assembly |
| A15 | Upper Sector Transducer |
| A18 | DC Interconnect Assembly |

3. Match the following board designations (which are plugged onto the motherboard) with their names:

- | | |
|-----|----------------------------|
| A7 | Read Preamp & Write Driver |
| A8 | Sector Count & Compare |
| A9 | Drive Control |
| A10 | I/O Multiplex |
| A11 | Encoder Assembly |
| A12 | Read/Write Control |
| A13 | Cylinder Address |

16. What 7900 Drive condition does the UNSAFE STATUS bit reflect?

17. Which Inbus bit is not used by the HP 7901?

18. Explain in your own words why the data is transmitted via one twisted pair line instead of using 16 inbus lines.

19. What will cause the SECTOR COMPARE signal to be asserted by the disc drive?

20. State four things that will cause the SEEK CHECK status bit to be asserted.

- A. _____
- B. _____
- C. _____
- D. _____

21. In your own words define the term "cylinder" as it applies to the HP 7900.

22. What is the purpose of the fourteen 16-bit words of preamble written on the sector?

8. What two conditions will cause the disc drive to assert the attention signal?

9. What feature allows the computer program or the controller to determine the reason for the attention signal being asserted?

10. What is the maximum number of attention signals that can be returned to the controller at any one time?

11. In your own words explain what causes the attention signal to drop and why this method was used to drop the attention signal.

12. What is the time period of the sector pulses being sent to the controller?

13. Explain the difference between the two signals DRIVE READY and ACCESS READY.

14. What does the DATA PROTECTED STATUS bit tell the controller and/or programmer?

15. Which switch controls the ON LINE STATUS bit? _____

33. If the Interlock Relay drops out what causes the action listed in questions 30 through 32?

34. Once the Run Relay is energized, the relay driver is turned off. What furnishes the ground to hold the Run Relay energized?

35. When the carriage is to be driven forward the polarity of the voltage on the Input Summing Mode line will be _____. When the carriage is to be driven backward the polarity will be _____. When the carriage is positioned on the center of a track the voltage on the Input Summing Mode line should be _____ volts.

36. The _____ gate will be turned on whenever the carriage is to do a Seek Home operation. The Seek Home operation can be initiated in two ways.

These are:

A. _____

B. _____

37. The _____ gate will be turned on when the carriage is to be driven forward. In order to drive the carriage forward using this gate, three types of information must be sent to the Disc Drive. These three types of information are:

A. _____

B. _____

C. _____

38. Using the information listed in A, B, and C of the previous question, the carriage can also be driven in reverse using the _____ gate.

39. Once the carriage is over the boundaries of the specified track, the _____ gate is turned on to position the heads exactly on the center of the track. When turned on, this gate causes the Input Summing Mode Line to follow the output of the _____.

23. What is the purpose of the one 16-bit word postamble written after the CRCC word?

24. What is the name of the type of erase that the HP 7900 uses?

25. What component allows AC to be applied to the spindle motor?

26. What five items are checked by the Interlock Relay?

- A. _____
- B. _____
- C. _____
- D. _____
- E. _____

27. What component causes AC to be applied to the spindle motor?

28. What component allows DC braking to be applied to the spindle motor?

29. What component allows the actuator assembly to be driven?

30. What will happen if the Servo Amp Relay drops out?

31. What two things will happen if the Interlock Relay drops out?

- A. _____
- B. _____

32. What will not happen if the Interlock Relay drops out?

46. When doing a forward seek, the A channel amplifier outputs the most positive voltage (before/after) the B channel amplifier. Therefore, the A channel (leads/lags) the B channel amplifier by 90 degrees.
47. When doing a reverse seek, the A channel amplifier outputs the most positive voltage (before/after) the B channel amplifier. Therefore, the A channel (leads/lags) the B channel amplifier by 90 degrees.
48. The output of the _____ amplifier directly feeds the Input Summing Mode line when doing a seek home operation.
49. The output of the amplifier (in question 48) is _____ when the heads are retracted, _____ when the heads are at a track greater than zero, and _____ when the heads are at track zero.
50. The retract circuitry formed by the batteries (+5V), the carriage retracted switch and the servo amp relay is *a/ways* used to retract the heads.
True or False? _____

40. The signal _____ going high enables turning on the fine positioning gate and the output of the _____ going high is the timing to tell the fine positioning gate exactly when to turn on.
41. When a cylinder address is sent to the Disc Drive the signal _____ tells the direction control whether to move or not and the signal _____ tells the direction control how fast to move.
42. The signal _____ is fed directly to the Input Summing Mode line when driving in reverse and inverted and fed to the Input Summing Mode line when driving forward. The reason for this is that this signal is always _____ when driving the actuator regardless of the direction the carriage is to be driven.
43. The signal _____ tells the direction control which direction to drive the carriage. When this signal is _____ the carriage will be driven forward and when the signal is _____ the carriage will be driven backward.
44. The signal _____ is (180 degrees out of phase/in phase) with the Input Summing Mode line. This signal is fed to a voltage amplifier where it (is/is not) inverted. Thus, the input to the power amplifier circuits are (in phase/out of phase) with the Input Summing Mode line.
45. Which of the following statements about the tachometer and velocity transducer amplifier are true?
- _____ A. The tach controls the speed of the actuator any time it moves.
- _____ B. The tach controls the speed of the actuator only when moving as a result of sending a cylinder address to the Disc Drive.
- _____ C. The output of the amplifier controls the Input Summing Mode line by applying a voltage that opposes the voltage applied by the FET gate.
- _____ D. The output of the amplifier is 180 degrees out of phase with the input.
- _____ E. The output of the amplifier does not feed the Input Summing Mode line, but controls the actuator by controlling the current applied to it.

6. A. 7900

1. a. $000_{(10)}$ through $202_{(10)}$.
b. $000_{(8)}$ through $312_{(8)}$.
2. a. $00_{(10)}$ through $23_{(10)}$.
b. $00_{(8)}$ through $27_{(8)}$.

3. 0 through 3

B. 7901

1. a. $000_{(10)}$ through $202_{(10)}$.
b. $000_{(10)}$ through $312_{(8)}$.
2. a. $00_{(10)}$ through $23_{(10)}$.
b. $00_{(8)}$ through $27_{(8)}$.

3. 0 through 1

7. The information gated via the inbus lines is only gated when asked for by asserting the Drive Address, the signal "Control" and bit 7 of the outbus lines. This status information is often called "non-stable status". The "stable" status is gated to the controller when that drive is selected via the Drive Select lines and is stable on the lines as long as that drive is selected.
8. Loading the heads or completing a seek operation.
9. The First Seek status bit being asserted says that the attention signal was sent because the heads loaded. If the attention signal was sent because a seek operation had been completed, the First Seek status bit would not be asserted.
10. Four
11. The attention signal is dropped by doing a status of that particular drive (Drive Select, Control and Outbus bit 7). Selecting the drive by the logical device number to interrogate status informs the disc drive that its attention signal is being serviced. The attention signal for that drive is then dropped.

7900 Disc
7900 Level I Answers
7900 O&S Manual
13215 O&S Manual

Answers to the student study questions.

1. A. + 5VDC
B. +12VDC
C. -12VDC
D. +24VDC
E. -24VDC
2. A1 – Indicator assembly
A2 – Servo Amp assembly
A3 – Upper Sector transducer
A4 – Lower Sector transducer
A5 – Board does not exist
A6 – Motherboard assembly
A14 – DC Brake assembly
A15 – Motor Control assembly
A18 – DC Interconnect assembly
3. A7 – I/O multiplex
A8 – Sector Count and Compare
A9 – Drive Control
A10 – Read/Write Control
A11 – Cylinder address
A12 – Encoder Assembly
A13 – Read Preamp and Write Driver
4. Gate Attention
5. To tell the disc drive what information is being transmitted over the Outbus lines.

23. The purpose of the one 16-bit word postamble is to clean up the track for an area after the CRCC word because the actual data track is not erased.
24. Straddle Erase.
25. Two components could have been listed, the Interlock Relay (A2K1) and the Brake Relay (A14K1). The Interlock Relay being energized helps enable the Run Relay via the signal DRIVE ENABLED and this was the answer desired. However, the Brake Relay must be de-energized in order to apply the AC to the spindle motor also.
26.
 - A. Power supply voltages.
 - B. Current through the encoder lamp.
 - C. The front door closed.
 - D. The Disc Cartridge in place.
 - E. All PC cards plugged in.
27. The Run Relay. One set of contacts triggers the triac control on the A15 board and applies the AC to the spindle motor.
28. Energizing the brake relay allows DC to be applied to the spindle motor to apply a braking action.
29. The Servo Amp Relay.
30. The carriage will retract.
31.
 - A. The Servo Amp Relay will drop out and the carriage retract.
 - B. The Run Relay will drop out and AC removed from the spindle motor.
32. The Brake Relay will not be able to energize so DC braking cannot be applied to the spindle motor.
33. Dropping the Interlock Relay drops +24VDC power to the Servo Amp Relay, Brake Relay and Run Relay.
34. The ground is provided through one set of contacts of the Run Relay and the Load Switch.

12. 24 microseconds.
13. Drive Ready means the heads are loaded and a fault condition does not exist. Access Ready means that the drive is not busy doing a seek operation.
14. The Data Protected status bit says that the selected platter has the protect switch set and cannot be written onto.
15. The protect/override switch on the A2 board.
16. Fault condition.
17. Inbus bit 5.
18. One twisted pair is used because the disc drive does not have a serializer/deserializer network. A twisted pair is used to facilitate using a differential amplifier, current level type signal, which is much less susceptible to induced noise.
19. The Present Sector Counter in the disc drive for the selected platter is incremented by the sector pulses until that counter equals the contents of the Sector Address Register.
20.
 - A. A cylinder address $\geq 313_{(8)}$.
 - B. A sector address $\geq 30_{(8)}$.
 - C. A head address ≥ 2 (7901 only)
 - D. A seek operation taking too long (seek time out)
21. A cylinder is all sectors on both surfaces of one platter with the heads held at one track (cylinder) address. With the heads at one cylinder address two cylinders are available, one consisting of the 48 sectors on the cartridge platter and the other consisting of the 48 sectors on the fixed platter.
22. The purpose of the fourteen 16-bit words of preamble is to set up the data separation circuitry in the controller so that the controller can detect the data bits at the rate they are actually being read rather than hoping the data bits are being read at the ideal rate (2.5 MHz).

- 45. A. True
- B. False
- C. True
- D. False
- E. False

46. Before
Leads

47. After
Lags

48. C channel

49. Positive
Negative
Zero volts

50. True

- 35. positive
negative
zero
- 36. Command Servo Home
 - A. Loading the heads.
 - B. Asserting the two signals SET HEAD AND SECTOR and SET CYLINDER at the same time.
- 37. Forward Velocity
 - A. Drive Select (Drive logical address)
 - B. The signal SET CYLINDER
 - C. The cylinder address over the outbus lines.
- 38. Reverse Velocity
- 39. Fine positioning
 - A channel amplifier
- 40. NOT MATCH
 - B channel shaper
- 41. NOT MATCH
 - VELOCITY COMMAND
- 42. VELOCITY COMMAND
 - Negative
- 43. NOT CARRY
 - Low
 - High
- 44. CURRENT COMMAND
 - 180 degrees out of phase
 - is
 - out of phase

HP 7900/7901 FAULT ISOLATION REPORT

NAME _____

TIME STARTED _____

INSTRUCTOR _____

TIME FINISHED _____

DATE _____

STUDENT PROBLEM NO. _____

1. Briefly describe the problem. _____

2. Briefly state what main assembly or subassembly you think is failing and why!

3. Show this form to the instructor before doing any scoping.

Instructor's Initials _____

4. What is the failing signal?

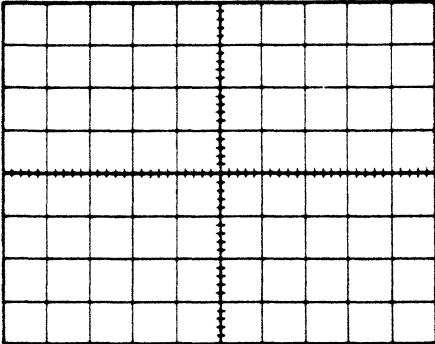
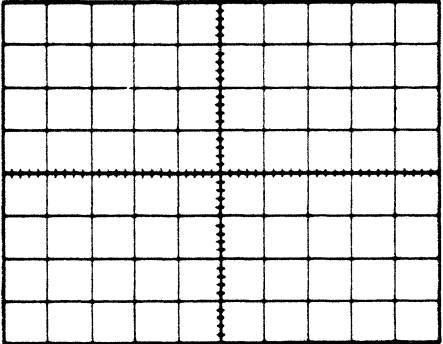
SHOULD BE		IS
	PROBLEM # _____ VOLTS/DIV _____ TIME/DIV _____ SYNC _____ SIGNAL _____	

5. Explain why the problem was giving the symptoms it did. _____

6. If you answered 2 above incorrectly, what symptom was overlooked or lead you astray?

HP 7900/7901 FAULT ISOLATION REPORT

NAME _____

TIME STARTED _____

INSTRUCTOR _____

TIME FINISHED _____

DATE _____

STUDENT PROBLEM NO. _____

1. Briefly describe the problem. _____

2. Briefly state what main assembly or subassembly you think is failing and why!

3. Show this form to the instructor before doing any scoping.

Instructor's Initials _____

4. What is the failing signal?

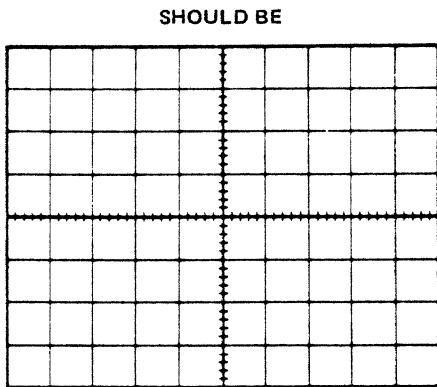

PROBLEM # _____
 VOLTS/DIV _____
 TIME/DIV _____
 SYNC _____
 SIGNAL _____

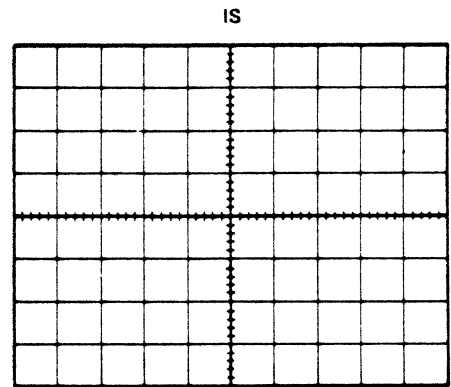

5. Explain why the problem was giving the symptoms it did. _____

6. If you answered 2 above incorrectly, what symptom was overlooked or lead you astray?

HP 7900/7901 FAULT ISOLATION REPORT

NAME _____

TIME STARTED _____

INSTRUCTOR _____

TIME FINISHED _____

DATE _____

STUDENT PROBLEM NO. _____

1. Briefly describe the problem. _____

2. Briefly state what main assembly or subassembly you think is failing and why!

3. Show this form to the instructor before doing any scoping.

Instructor's Initials _____

4. What is the failing signal?

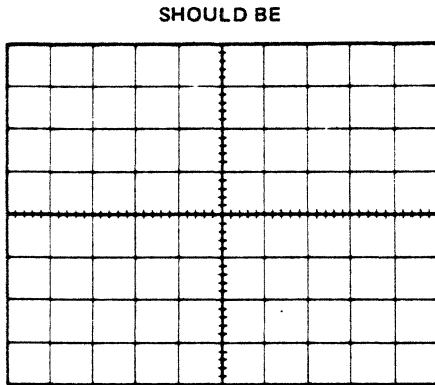

PROBLEM # _____
 VOLTS/DIV _____
 TIME/DIV _____
 SYNC _____
 SIGNAL _____

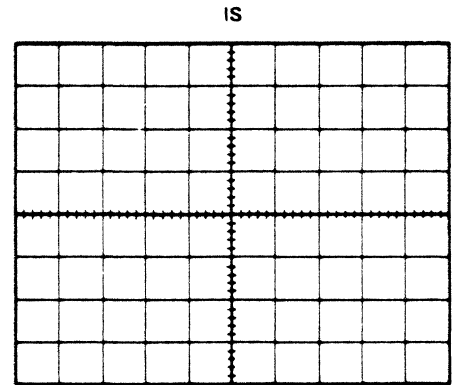

5. Explain why the problem was giving the symptoms it did. _____

6. If you answered 2 above incorrectly, what symptom was overlooked or lead you astray?

reference materials

SECTION
IV

SECTION IV

CONTENTS

Troubleshooting Aids	4-1
Troubleshooting Techniques	4-8
Shoot the Moon	4-11
Baby Sitter	4-14
IC Diagrams	4-16

SERVICE NOTES

Spare Parts	4-23
Tools and Test Equipment	4-28
Installation Procedures	4-30
Head Disc Interference	4-36
Drive Fault	4-38
Encoder PCA	4-40
Trickle Charge	4-44
Cartridge Receiver	4-45
Operational Amplifier	4-46
Motor Power Module	4-47
PM Schedule	4-48
Operator Precaution	4-50
Static Discharge Strap	4-51
Encoder Lamp Replacement	4-52
Head Alignment	4-53
Spare Parts	4-57
HP7901 Tools	4-65
HP7901 Installation	4-67
HP13210 Improvement	4-70
Intermittent Data Errors	4-72
Daisy Chaining	4-73
Intermittent Seek	4-74
Multi-Drive Environment	4-75
HP7901 Power Supply Fuse Label	4-76

TROUBLESHOOTING AIDS FOR CUSTOMER ENGINEERS

Almost every successful problem solving sequence may be broken down into three steps:

1. Recognize that a problem exists.
2. Define the problem.
3. Solve the problem.

The following notes are aimed at overcoming some of the mental blocks which hinder CE's solutions to hardware problems.

In trying to help a mentally-blocked person to solve (with that same blocked mind) his own mental problems, the emphasis is necessarily in Recognizing and Defining the problems (see 1 and 2 above). Thus, by simply listing some common mental blocks, and hoping that the CE will retain them in the most conscious part of his mind, a great step has been made towards overcoming them.

Together with this list of common mental blocks (1-11 below, with a summary at 12 below), some comments on simulating and repairing the physical hardware failures themselves also appear (13-16 below).

These notes read sequentially, but this does not mean that they should only be considered sequentially. Indeed (since any complex problem solving sequence has many different asynchronous levels — each level consisting of several simple problem solving sequences), every note is constantly applicable. Therefore, these notes should be read over and over again — until all of the notes merge together in the reader's mind. (The cross references may be omitted on the first two readings.)

Finally, these notes usually take the form of questions which the CE can ask himself or maxims which the CE can repeat to himself. This format serves two purposes:

1. It helps the CE to retain these notes.
2. It encourages the CE to talk to himself; and all successful problem solvers talk to themselves.
1. You must want to fix the problem.
 - a. The emphasis is on "you" — this is quite different from wanting to see the problem fixed.
 - b. Before you can possibly want to fix a hardware problem you must truly believe that a hardware problem exists (in contrast to a software problem).
2. You must believe that *you* can fix the problem.
 - a. Again, the emphasis is on "you".
 - b. Remember that, except for design errors, etc. (see 16g), the equipment once ran properly.

3. Gather information about the problem.
 - a. Determine what should have happened.
 - b. Determine what really happened.
 - c. Information which is not immediately and obviously useful should also be gathered and retained (see 4, 6e, and 14d).
 - d. What you *know* about the problem should be stated both precisely and concisely (in 100 words or less, what do you know?).
 - e. What you have *assumed* about the problem should be stated both precisely and concisely (in 500 words or less, what do you think you know?).
 - f. What you *don't know* about the problem should be stated both precisely and concisely (in 1,000 words or less, what don't you know?).
4. Be especially watchful for "amazing" information.
 - a. The more outrageously illogical a failure indication appears to be, the more likely it is that the indication could only have resulted from one, very specific component failure (but see 6a and 16g).
 - b. Therefore, logically interpreting one piece of "amazing" information is quite often equivalent to several hours of troubleshooting with "ordinary" information.
 - c. But before you can interpret "amazing" information, you must overcome your amazement.
5. Define the problem.
 - a. The definition should be both precise and concise (in 10 words or less, what's wrong?).
 - b. Every hardware problem solving sequence can be looked at as a series of redefinitions of the problem.
 1. Each redefinition of the problem directs subsequent information gathering and the new information gathered results in yet another redefinition of the problem (see 3).
 2. Each redefinition attempts to isolate the failure to a smaller and smaller physical area.
 3. The problem gets fixed when a redefinition (e.g.; J006 is bad) has isolated the failure to an easily replaceable area (e.g.; a logic card).
6. Attack one problem at a time.
 - a. In the case of multiple problems, attack one problem and forget all other problems (but see 6d) — do not become confused or overwhelmed by multiple problems.
 - b. Choose the easiest problem to attack (and see 6e).
 - c. But choose the problem which is not influenced by any of the other problems (e.g.; fix the memory before attacking the card reader test program failure; and, if any test program reports two separate failures, attack the failure that was reported first).
 - d. When you fix one problem (see 6b), you will probably find that you have fixed all of your problems. When a system in the field goes down, it is usually caused by only one component failure — multiple problems are usually related.
 - e. Conversely, a single component failure will often cause several, seemingly unrelated problems. Therefore, do not be in too big of a hurry to attack the first problem you see — an easier problem may exist (see 3 and 6b).

7. Match your troubleshooting method to the problem.
 - a. Hit or Miss — almost all good CE's will initially attack a problem using this method (see, for instance, 13d2). A CE usually knows the weak spots in his system; and the CE's job is to get the system up as soon as possible. However, you will almost never fix a hard problem using this method. Therefore, you must recognize when to abandon this method (perhaps the first time you break for coffee).
 - b. Logical — in order to use this method you must understand both the problem and the equipment. Most hard problems will be fixed using this method. In practice, of course, the Logical method is always used in combination with the Hit or Miss method — nobody completely understands any problem or any equipment.
8. Be wary of impatience.
 - a. Impatience results in sloppy technique. And it is your technique which both controls and monitors all of your actions.
 - b. Impatience is especially hard to withstand once you have found (or think you have found) the solution to the problem.
9. Be suspicious of every fact.
 - a. Anything which you know, or think you know, about the problem may be wrong.
 - b. Any conclusion which you have drawn may be invalid — Is the conclusion inescapable? Is no other conclusion possible (see 3e and 3f)? Is there any way to verify the conclusion?
10. Hold on to the problem.
 - a. Do not lose sight of the current problem definition (see 5b, especially 5b1).
 - b. Do not stray far from the current problem definition without redefining the problem (see 5b, especially 5b1).
 - c. Relate each new problem redefinition to every former problem definition (see 5b).
 - d. Confirm each new problem redefinition (see 5b and 9, especially 9b).
11. Resist details.
 - a. Retain an overview of the problem: Do not lose sight of the chain of former problem definitions — especially the earliest, most general links (see 5b and 10c).
 - b. Keep your current picture of the problem as big as possible: Narrow your viewpoint only if either the broader viewpoint is barren of further information or you are "hot on the trail" of the problem.
 1. Gather general information (see 3).
 2. Make broad problem definitions (see 5b).
 3. Work at a gross level.

(e.g.; Be reluctant to exchange a failing Fortran program for its Machine Language object code listing. And be reluctant to exchange the console for a scope probe.)

12. If you run out of ideas, you are dead.
 - a. First: You must recognize when you are stuck. This is never easy – especially if you are really involved in the problem.
 1. Stop every hour and evaluate your progress (see 11a).
 2. But remember: Not every problem can be solved in an hour.
 - a. Confidence in your problem information (see 3) and definitions (see 5) will prevent you from abandoning a mode of attack too soon.
 - b. Do you still want to fix the problem (see 1)?
 1. Frustration can breed both depersonalization of the problem and indifference toward its solution.
 - c. Do you still believe that you can fix the problem (see 2)?
 1. Frustration can breed self-doubt.
 2. And, in truth, it is only because you once had some ideas about the problem that you ever believed you could fix the problem.
 - d. Try something different.
 - e. Use previously unused information (see 3c and 4).
 - f. Look for new information (see 3).
 1. Verify some of your assumptions (see 3e).
 2. Resolve some of your unknowns (see 3f).
 - g. Look at old information from a different angle (i.e., state the information differently; see 3d).
 - h. Regather old information (see 3, 8 and 9).
 - i. Back up to some previous point where you had a hold on the problem (see 10).
 1. You may be lost – and are now wandering around without direction (see 10a).
 2. You may have lost the problem – and are now troubleshooting something that is not even failing (see 10b, 10c, and 10d).
 - j. Enlarge your current Picture of the problem (see 11b).
 - k. Look at the problem from a different angle (i.e.; define the problem differently; see 5).
 - l. Change your troubleshooting method (see 7).
 - m. If you have multiple problems, attack another problem (see 6, especially 6d and 6e).
 - n. Stop and think for awhile – allow any half-submerged ideas to come to the surface.
 - o. Try getting a fresh idea from someone else.
 1. Describe the problem to this someone in general terms only – detailing the history of how you got stuck will only serve to stick him too.
 - p. Try anything – including going to the men's room, going out to eat, or going home to bed.

13. Simulate the problem.
 - a. A controlled, understandable program that fails gives you a controlled, understandable problem to attack.
 - b. First: Watch CAREFULLY while the user's program fails – do not believe any 2nd hand reports of the failure.
 - c. Second: Examine the user's failure (see 3).
 - d. Then: Try a controlled simulation of the user's program (using either your own code or patched-together pieces of the user's code).
 1. The more faithful the simulation is to the user's program, the better chance you will have of duplicating the failure. (Use the same memory banks as the user; using delays, make your I/O rates the same as the user's; if possible, use the user's data patterns – better yet, use his actual cards, tapes, etc.)
 2. When attempting a controlled simulation with your own code, the usual technique is to start with a simple, non-failing program. Operations are added and/or altered until the failure appears (see 13e and 13f). Then operations which do not influence the failure are deleted (see 13k). The results are a simple, failing program. This is Hit or Miss troubleshooting (see 7a).
 3. When attempting a controlled simulation with patched-together pieces of the user's code, the usual technique is to start with a complex, failing program (basically the user's program). Operations which do not influence the failure are deleted (see 13k). The results are a simple, failing program. This is Logical troubleshooting (see 7b).
 - e. If the simulation program does not fail, you may be doing something different – WHAT? Perhaps the user's program is using format level 2 for double spacing the Line Printer while yours is using a different type of spacing.
 - f. If the simulation program does not fail, you may not be doing enough – EXPAND! (Perhaps the user's program has two data channels running I/O concurrently while yours is using only one data channel.)
 - g. If the simulation program does not fail, the failure may have gone away – intermittent failures may have to be excited by shock, voltage, temperature, or humidity changes – Does the user's program still fail?
 - h. Any unexplained action by the simulation program may be a failure – explain every effect of the simulation program.
 - i. Any failure of the simulation program is a good problem to attack – the failure need not appear identical to the user's failure (see 6d and 6e).
 - j. Once the simulation program is failing, assure yourself that the failure is being caused by faulty hardware and not by a bug in the program.
 - k. Then: Delete every operation which does not influence the failure. The result should be a simple, controlled, understandable program that exposes a hardware failure.

14. Become familiar with the problem.
 - a. Vary the failing simulation program — every variation is a piece of information; every non-failing variation is a piece of information.
 - b. Every trial simulation program which did not fail is a piece of information (see 13e, 13f and 13g).
 - c. Every operation necessary for the failure of the simulation program is a piece of information; Any operation unnecessary for the failure of the simulation program may be a piece of information (see 13k).
 - d. Any previously unused information may now become meaningful (see 3c).
 - e. Any other problem, if multiple problems exist, may be a piece of information (see 6d and 6e).
 - f. Enough understanding of the problem can sometimes be gained at this stage to logically determine the failing component — by finding a unique component which is both used by every failing program and not used by every non-failing program.
15. Isolate the problem.
 - a. Make the simulation program fail as often as possible (by selecting the most critical pattern, delays, temperature, etc.).
 - b. Make the simulation program fail as simply as possible (by eliminating any convenience code, like pattern generation and pattern checking subroutines, which had facilitated varying the program at 14a).
16. Fix the problem.
 - a. This actually means to repeat the above techniques (and to avoid the above pitfalls) at a different level — the electrical or mechanical level instead of the program level.
 - b. And one of the questions which must be answered (sometimes a hard one) is whether the problem is electrical or mechanical.
 - c. Another (usually harder) question to be answered is which piece of equipment in the system is failing (but see 16e).
 - d. Using the scope, look for a bad signal (assuming the problem is electrical; see 16b).
 - e. Any bad signal is OK to start with — even the appropriate I/O signal from a failing peripheral (e.g.; the parity error status line, the reply line, etc. — and after all, the I/O signals from a peripheral are the only means by which any program, including your simulation program, knew when a peripheral failed).
 - f. Any signal which you can not fully explain may be a bad signal — explain the rise, fall, amplitude, duration, and repetition rate of every signal.
 - g. Trace back the bad signal to the failing component. (If the problem is not a component failure (e.g.; a design error or wiring error) but you have absolutely assumed that a component is failing, you will now be hopelessly stuck — Did the equipment ever run properly?)
 - h. Replace the failing component (see 5b3).
 - i. Make sure the bad signal is now good and the simulation program no longer fails.
 - j. You can be fairly sure that you have fixed the problem and not just (temporarily) eliminated the (current) failure indications — you understood (and had control of) the problem. (If the user's program still fails, you have a true multiplicity of failures, return to 1.)

17. Analyze your problem-solving sequence.
 - a. Underline the statements in this list which proved helpful to you – you are prone to need the same help in the future.
 - b. Add other statements to this list which would have proved helpful to you – again you are prone to need the same help in the future.
 1. Of course, the more general the statement, the more helpful it will prove to be – Extract general statements from your specific experiences.
 - c. Can any good luck which befell you be translated into a statement and added to this list – so that the same good luck may be consciously courted in the future.

TROUBLESHOOTING TECHNIQUES

Troubleshooting is a systematic, logical approach to determine and correct any fault in the equipment operation. In its full meaning, troubleshooting requires the following of the customer engineers:

1. Know in detail how the system works under normal conditions. The engineer should study the equipment to determine how each standard and special circuit works when operating normally. This will increase his troubleshooting efficiency.
2. Know the function of, and how to manipulate, all equipment controls and adjustments. Aging equipment often requires readjustment and realignment of critical circuits. Also, it would be somewhat difficult to check out a piece of equipment without knowing how to set its controls.
3. Know how to use test equipment and technical manuals or other performance data. Making voltage measurements with a multimeter set on a current scale would lead to some interesting, but wrong, observations. Technical manuals generally are the engineer's best source of information, containing both operational and performance data.
4. Be able to analyze logically the information of an improperly operating system.
5. Be able to apply a systematic, logical procedure to locate the trouble. The time you save may be your own.
6. Be able to use the proper tools to repair the trouble.
7. Perform a check-out procedure on the repaired system to ensure proper operation. The trouble you repaired may have had lots of company. The system may require readjustment because of the repair.

COMPLETE TROUBLESHOOTING PROCEDURE

The preceding troubleshooting techniques can be summarized into four major areas:

1. Determine the symptoms.
2. Localize the trouble to a functional unit.
3. Isolate the trouble to a circuit.
4. Locate the specific trouble.

The following paragraphs describe briefly the systematic, logical troubleshooting procedure.

DETERMINE SYMPTOMS

In order to repair any electronic equipment, you must first determine whether it is operating properly or whether there is something wrong. To satisfy this requirement completely, you must be thoroughly familiar with all the operational characteristics of the equipment. This means that you must provide valid answers to the questions: What is this equipment supposed to do? and How well is this job being done?

Determine Symptoms means that you must know what the equipment is supposed to do when it is operating normally and, in addition, that you must be able to recognize when the normal job is not being done. The normal and abnormal symptoms are then analyzed to formulate in your mind the question: Where in the equipment could there be trouble that will produce these symptoms?

LOCALIZE TROUBLE TO FUNCTIONAL UNIT

Systems can be subdivided into units or areas which have a definite purpose or function. The term function is used here to denote an electronic operation performed in a specific area of the system.

In order to localize the trouble intelligently — systematically and logically — you must have a knowledge of the functional units of the equipment and then correlate all the symptoms previously determined. Thus, the first consideration in localizing the trouble to a functional unit is really a valid estimate of the area in which the trouble might be in order to cause the indicated symptoms. Initially, several technically accurate possibilities may be considered as the probable trouble area.

ISOLATE TROUBLE TO CIRCUIT

After the trouble is localized to a single functional unit, the next step is to isolate the trouble to a circuit in the faulty unit. To do this you consider the signal paths in the circuitry that contain the indicating instruments or other built-in aids that point to abnormal performance. By concentrating on this circuitry and ignoring the other circuits that produce normal indications, you narrow down (isolate) the limits wherein the possible trouble lies. You then use test equipment such as an oscilloscope, a meter, etc., for "signal tracing" in the suspected faulty area. Thus, by making valid educated estimates and properly using the applicable diagrams, bracketing techniques, signal tracing, and signal defective circuit.

LOCATE SPECIFIC TROUBLE

Although this troubleshooting step mentions only, "locate the specific trouble," it also includes a final analysis, or review, of the complete procedure, along with using repair techniques to remedy the trouble once it has been located. This final analysis will enable you to determine whether some other malfunction caused the component to become faulty or whether the component located is the actual cause of the equipment trouble.

When trying to locate the trouble, inspection using the senses — sight, smell, hearing, and touch — is very important. This inspection is usually performed first, in order to gather information that may more quickly lead to the defective component. Among the things to look for during the inspection using the senses are burned, charred, or overheated components, and arcing in the high voltage circuits. In equipment in which it is relatively easy to gain access to the circuitry, a rapid visual inspection should be performed first. Then the active device can be removed from the circuit and checked. On the other hand, in equipment in which access to the circuitry is difficult, the active device should be removed from the circuit and checked before performing the visual inspection. In many cases, the trouble can be located by using these two steps. Next in line for locating the specific trouble is to use an oscilloscope to observe waveforms and a meter to measure voltages. The last test usually is to use a meter to make resistance and continuity checks to pinpoint the defective component.

Figure A is a block diagram showing the relationship between the steps along with the specific things you must do or use to complete the requirements of each step satisfactorily. It can be seen that the first step — determining the symptoms — requires the use of the senses, observation of the system performance, previous knowledge of system operation, the manipulation of the operational controls, and the recording of notes. Determining the symptoms presupposes the ability to recognize improper indications and, in addition, knowledge of the manipulation of operational controls and data recording (note taking) of the effect they have on the symptoms.

The second step — localizing the trouble to a functional unit — depends upon the data observed and recorded in the first step plus the use of a functional area could cause the indicated symptoms? Then bracketing, or narrowing down the probable deductions to a single functional unit, is used along with the test equipment to actually pinpoint the faulty function. The observations in this step refer to noting the indications of the testing devices used to localize the trouble.

The third step of the procedure — isolate the trouble to a circuit — uses all the information gathered up to this time. The main difference is that now servicing block diagrams and schematic diagrams are used instead of a functional block diagram. The fourth step — locate the trouble — is where all the findings are reviewed and verified to ensure that the suspected part is the cause of the failure.

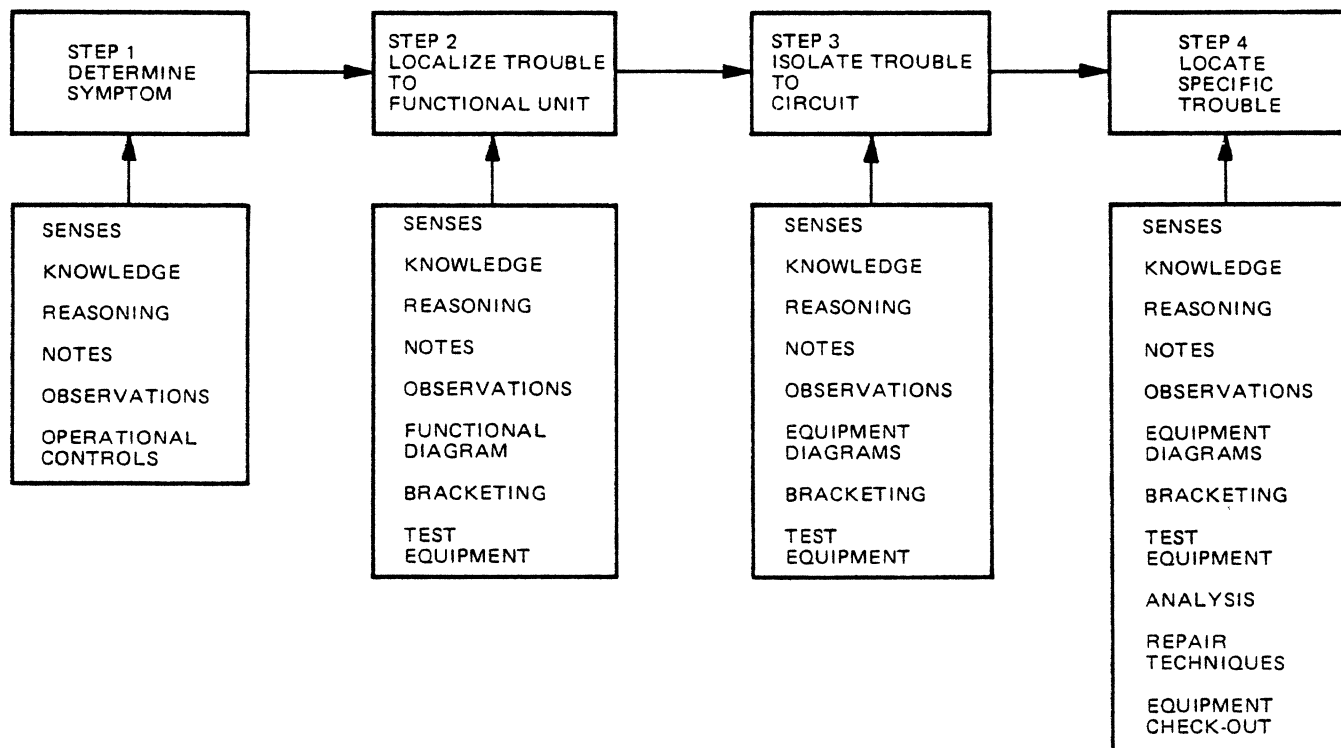

Figure A. Block Diagram Representation of the Overall Troubleshooting Procedure

"SHOOT THE MOON"

The basic objective of the "Shoot the Moon" technique is to detect the presence of a signal or change in voltage that cannot be positively observed with a normal single sweep set-up.

One use would be in detecting an impulse which is very infrequent such as a noise spike. Another use is when the pulse is nonrepetitive, such as when the machine will not run continuously and must be single-cycled through an operation. Initial scope settings are as follows:

- a. Remove all connections from the front of the scope with the possible exception of the ground wire.
- b. Set up the controls.
- c. Set the TIME/DIV control to 0.1 second.
- d. Rotate the FOCUS control fully counter-clockwise.
- e. Reduce the INTENSITY. (This is done to prevent the slow moving trace from burning the phosphor coating on the inside of the CRT. It also makes a single sweep easier to see. You should now be seeing an enlarged spot or "moon" continuously sweeping across the CRT.)
- f. With the Channel 1 VERTICAL control, position the center of the "moon" on the center horizontal line of the graticule, which will be used as a reference level.
- g. With the HORIZONTAL POSITION control, position the start of the trace at the extreme left of the graticule.

The values of the following settings are used for illustration only. They will vary depending on the voltage to be detected in actual application. The object of these settings is to cause the beam to sweep across the CRT only if we detect a signal of a certain amplitude at the Vertical Input to Channel 1.

Assuming that you wanted to detect an impulse of at least 5 volts amplitude in a positive direction, proceed as follows:

- a. Set the Channel 1 VOLTS/DIV control to 0.5 volts.
- b. With the Channel 1 VERTICAL POSITION control, move the trace up one major division on the graticule. (This would be the level to which a 0.5 volt input signal would move the trace, if using a x10 probe.)
- c. Move the COUPLING switch to DC. (This will stop automatic triggering of the sweep and allow the sweep to be triggered with an input signal to the scope.)
- d. Set the SLOPE switch to PLUS. (This is done because you are trying to detect a positive-going signal.)
- e. Set the SOURCE switch to INTERNAL. (This is done because the circuit to be tested will be connected to the Vertical Input hub.)
- f. To cause the sweep to trigger at the 5 volt setting, first start with the LEVEL control fully clockwise to the extreme plus direction.
- g. Now, while watching the CRT for a sweep, slowly turn the LEVEL control counter-clockwise until one sweep occurs. (The LEVEL control is now set to trigger on a signal of plus 5 volts from the reference line at the center of the graticule.)

“SHOOT THE MOON”

The basic objective of the “Shoot the Moon” technique is to detect the presence of a signal or change in voltage that cannot be positively observed with a normal single sweep set-up.

One use would be in detecting an impulse which is very infrequent such as a noise spike. Another use is when the pulse is nonrepetitive, such as when the machine will not run continuously and must be single-cycled through an operation. Initial scope settings are as follows:

- a. Remove all connections from the front of the scope with the possible exception of the ground wire.
- b. Set up the controls.
- c. Set the TIME/DIV control to 0.1 second.
- d. Rotate the FOCUS control fully counter-clockwise.
- e. Reduce the INTENSITY. (This is done to prevent the slow moving trace from burning the phosphor coating on the inside of the CRT. It also makes a single sweep easier to see. You should now be seeing an enlarged spot or “moon” continuously sweeping across the CRT.)
- f. With the Channel 1 VERTICAL control, position the center of the “moon” on the center horizontal line of the graticule, which will be used as a reference level.
- g. With the HORIZONTAL POSITION control, position the start of the trace at the extreme left of the graticule.

The values of the following settings are used for illustration only. They will vary depending on the voltage to be detected in actual application. The object of these settings is to cause the beam to sweep across the CRT only if we detect a signal of a certain amplitude at the Vertical Input to Channel 1.

Assuming that you wanted to detect an impulse of at least 5 volts amplitude in a positive direction, proceed as follows:

- a. Set the Channel 1 VOLTS/DIV control to 0.5 volts.
- b. With the Channel 1 VERTICAL POSITION control, move the trace up one major division on the graticule. (This would be the level to which a 0.5 volt input signal would move the trace, if using a $\times 10$ probe.)
- c. Move the COUPLING switch to DC. (This will stop automatic triggering of the sweep and allow the sweep to be triggered with an input signal to the scope.)
- d. Set the SLOPE switch to PLUS. (This is done because you are trying to detect a positive-going signal.)
- e. Set the SOURCE switch to INTERNAL. (This is done because the circuit to be tested will be connected to the Vertical Input hub.)
- f. To cause the sweep to trigger at the 5 volt setting, first start with the LEVEL control fully clockwise to the extreme plus direction.
- g. Now, while watching the CRT for a sweep, slowly turn the LEVEL control counter-clockwise until one sweep occurs. (The LEVEL control is now set to trigger on a signal of plus 5 volts from the reference line at the center of the graticule.)

Before connecting the circuit to be tested to the Vertical Input hub, you must change the sweep level to the middle of the graticule which is the zero or reference level. To do this:

- a. Move the COUPLING switch to the AUTOMATIC position which will cause the trace to appear.
- b. With the VERTICAL POSITION control, move the trace to the horizontal center line of the graticule.
- c. Now return the COUPLING switch to the DC position.

The scope is now set up to detect a positive-going signal of 5 volts or more. At this time, you would connect the circuit to be tested to the Vertical Input hub. To illustrate:

- a. Turn the CALIBRATOR to the 5 volt setting.
- b. Momentarily touch the probe tip of the x10 probe to the CALIBRATOR OUTPUT hub. (You should see one sweep across the CRT. If you do not see a sweep, then the LEVEL control is improperly adjusted and you will have to readjust it.)
- c. Touch the probe tip to the CALIBRATOR OUTPUT hub again and you will see the trace again.

We have sensed a voltage of short duration and caused a slow trace to be displayed which is very easy to see. If the signal should occur again while the beam is moving across the CRT, the trace would be deflected vertically. This is insignificant, because the scope is not set up to display the waveform of the signal. To illustrate:

- a. Hold the probe tip on the CALIBRATOR OUTPUT hub and the beam will be continuously deflected by the Calibrator square wave. (The trace should now appear as two "moons" sweeping across the CRT. This is because the Calibrator signal frequency is very high in comparison to the time base setting being used.)
- b. Remove the probe tip from the CALIBRATOR OUTPUT hub.
- c. Change the CALIBRATOR setting to the 2 volt position.
- d. Momentarily touch the probe tip to the CALIBRATOR OUTPUT hub. (There should not be a trace because the 2 volt signal is less than what the scope was set up to detect. If there was a trace then the LEVEL control was turned too far in the counter-clockwise direction and you should remake this adjustment.)
- e. Change the CALIBRATOR to 10 volts.
- f. Momentarily touch the probe tip to the CALIBRATOR OUTPUT hub. (This should cause the beam to sweep across the CRT one time.)

From this you can see that any signal of less than 5 volts will not trigger the scope and you will not see a trace. Any signal of 5 volts or greater will trigger the scope and you will see a slow moving trace or "moon" on the CRT. It is also possible to cause the sweep to be triggered by a negative voltage. To demonstrate this:

- a. Move the INVERT CHANNEL 1 switch to the INVERT position. (This is done to make the positive voltage from the Calibrator Output appear as a negative voltage to Channel 1.)
- b. Set the SLOPE switch to MINUS since the signal to be detected is a negative-going pulse.
- c. Move the COUPLING switch to the AUTOMATIC position to make the trace appear.

- d. With the Channel 1 VERTICAL POSITION control, center the trace on the first major division below the centerline of the graticule.
- e. Move the COUPLING switch to the DC position.
- f. To adjust the triggering level, first turn the LEVEL control fully counter-clockwise to the extreme minus position.
- g. Then while watching the CRT for a trace, slowly rotate the LEVEL control in a clockwise direction until one sweep occurs.
- h. Move the COUPLING switch to the AUTO position to cause the trace to appear.
- i. With the Channel 1 VERTICAL POSITION control, center the trace on the center horizontal line of the graticule.
- j. Move the COUPLING switch to the DC position.

The scope is now set up to detect a negative-going signal of 5 volts or more. To prove this:

- a. Turn the CALIBRATOR to the 5 volt position.
- b. Momentarily touch the probe tip to the CALIBRATOR OUTPUT hub. (You should see a trace across the CRT. If you do not see a trace, then the LEVEL control is improperly adjusted and the adjustment must be remade.)
- c. Change the CALIBRATOR to the 2 volt position.
- d. Momentarily touch the probe tip to the CALIBRATOR OUTPUT hub. (You should not see a sweep. If you do, the LEVEL control is improperly adjusted and the adjustment must be remade.)

For this demonstration you use the Invert Channel 1 switch in the INVERT position. This was only for illustration purposes and would not be done in an actual application.

It is important to remember that the "Shoot the Moon" technique will only detect the occurrence of a signal of some pre-determined amplitude. It will not indicate the maximum voltage of the signal. It will not show the duration of the signal, nor will it show any time relation between the signal being detected and any other signal in the machine being serviced.

“BABY SITTER”

With the “Shoot the Moon” procedure, we are able to detect a signal that is intermittent or nonrepetitive. However, this requires that you constantly view the CRT for a sweep. This is very undesirable if the trouble is highly intermittent and you have to watch the CRT for a long period of time.

By using the dual input feature of the scope, we can cause the scope to remember if it detected a signal that caused a sweep. When using the scope this way, it is commonly referred to as a “Baby Sitter.” To use the scope as a “Baby Sitter”:

- a. Set it up to “shoot the moon” on Channel 1. (The scope should already be set up as a result of the previous practice problem. If it isn’t, set it up to “shoot the moon” on Channel 1.)
- b. Turn the Mode switch to Channel 2.
- c. Set the Channel 2 VOLTS/DIV control to the same setting that you are using for Channel 1.
- d. Move the COUPLING switch to the AUTO position to cause the trace to appear.
- e. With the Channel 2 POSITION CONTROL, center the sweep on the same line that you are using for reference on Channel 1.
- f. Move the COUPLING switch to the DC position.
- g. Make sure that the TRIGGER CHANNEL 1 ONLY control is pushed in.
- h. Turn the Mode switch to the ALTERNATE position.
- i. Remove the patch cord from the Channel 1 Vertical Input and plug it into the CALIBRATOR OUTPUT hub.
- j. Momentarily touch the probe tip from Channel 1 to the CALIBRATOR OUTPUT hub. (This may or may not cause a trace on the CRT.)
- k. Momentarily touch the probe tip from Channel 2 to the CALIBRATOR OUTPUT hub. (This should cause one sweep on the CRT.)
- l. Touch the CALIBRATOR OUTPUT hub alternately using the Channel 1 and Channel 2 probe tips. (You should see a trace each time you touch the CALIBRATOR OUTPUT hub.)
- m. If the last probe tip you used was Channel 1, then momentarily touch the CALIBRATOR OUTPUT hub using the CHANNEL 2 probe tip.
- n. Once more, touch the CALIBRATOR OUTPUT hub using the CHANNEL 2 probe tip. (You should not see a trace. This is because you are using the ALTERNATE position of the Mode Switch.)

The Channel 2 input is now ineffective until Channel 1 receives a signal of sufficient amplitude to trigger the sweep. (You can use this feature to remember that a signal has been detected at the Channel 1 input.)

Now let me talk for a moment about how you would apply the technique to an actual machine application. To use this set-up on a machine:

- a. Connect the circuit to be monitored to the Channel 1 input.
- b. Next you would trigger Channel 2 by applying a voltage of the same amplitude as the signal to be detected. (If it is a plus voltage, you could use the CALIBRATOR OUTPUT. If it is a minus voltage, you would have to use a voltage from the machine.)

When the circuit to be monitored is connected to Channel 1 input, the Channel 2 has been triggered, then the scope is said to be "armed."

This simply means that the scope is ready to detect a signal from the machine. Channel 1 will be triggered by a signal of the pre-determined value. A second signal to Channel 1 will not cause triggering. This is because we are on ALTERNATE mode, and Channel 2 cannot be triggered because it has no input.

Even though you were not watching the CRT, you can test the scope to see if a signal was detected.

Testing the "Baby Sitter" is accomplished by applying the "arming" voltage to the Channel 2 Input. If this causes a trace on the CRT, then there **MUST** have been a signal to Channel 1. If this does **NOT** cause a trace on the CRT, then there **COULD NOT** have been a signal to Channel 1. (This, in essence, is what the "Baby Sitter" is.)

It enables us to monitor a particular circuit without actually being present at the scope as long as power is maintained both on the scope and the machine. This could be hours or days.

From this you can see that we could even monitor the circuit while the customer used the machine.

One additional precaution to be observed is this: When the scope is set up and left to monitor a circuit, it is good practice not to leave a wire connected to the Channel 2 input. This is because there would be a possibility of triggering Channel 2 with a noise signal, and thus inadvertently rearming the scope.

MC1733/C

(HP 1820-0477)

MONOLITHIC DIFFERENTIAL VIDEO AMPLIFIER

... a wideband amplifier with differential input and differential output. Gain is fixed at 10, 100, or 400 without external components or, with the addition of one external resistor, gain becomes adjustable from 10 to 400.

- Bandwidth – 120 MHz typical @ $A_{VD} = 10$
- Rise Time – 2.5 ns typical @ $A_{VD} = 10$
- Propagation Delay Time – 3.6 ns typical @ $A_{VD} = 10$

Characteristic	Symbol	Min	Typ	Max
Differential Voltage Gain				
Gain 1	400	250	400	600
Gain 2	100	80	100	120
Gain 3	10	80	10	12

TYPICAL APPLICATIONS

Figure 1 – Basic Circuit

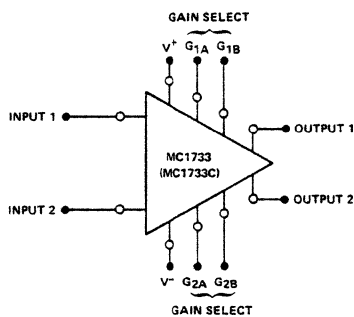
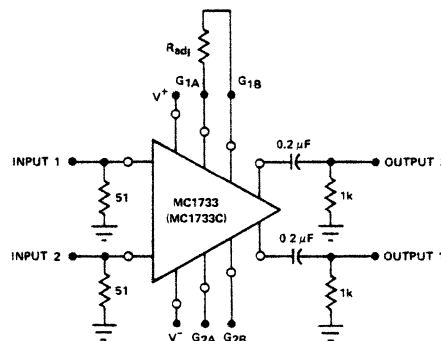
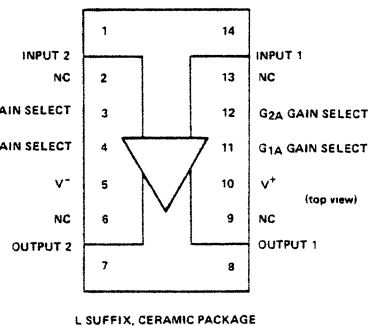
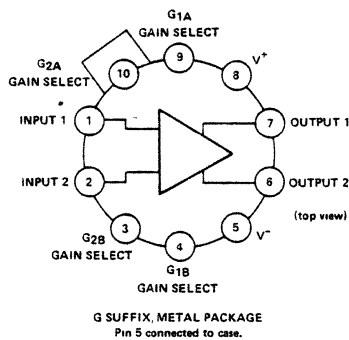

Figure 2 – Voltage Gain Adjust Circuit



CONNECTION DIAGRAMS



USED ON BOARDS: A13 U1

NOTE: THIS INFORMATION IS FOR TRAINING PURPOSES ONLY.

LM710C

(HP 1820-0398)

VOLTAGE COMPARATOR
GENERAL DESCRIPTION

The LM710C is a high-speed voltage comparator intended for use as an accurate, low-level digital level sensor or as a replacement for operational amplifiers in comparator applications where speed is of prime importance. The circuit has a differential input and a single-ended output, with saturated output levels compatible with practically all types of integrated logic.

The LM710C is useful as a pulse height discriminator, a voltage comparator in high-speed A/D converters or a go, no-go detector in automatic test equipment. It also has applications in digital systems as an adjustable-threshold line receiver or an interface between logic types.

TYPICAL APPLICATIONS

Schmidt Trigger

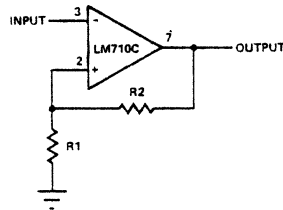

Line Receiver With Increased Output Sink Current

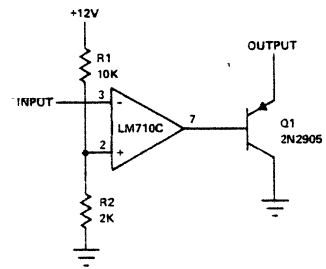

Pulse Width Modulator

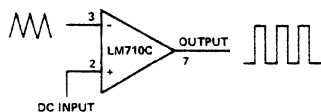

Level Detector With Lamp Driver

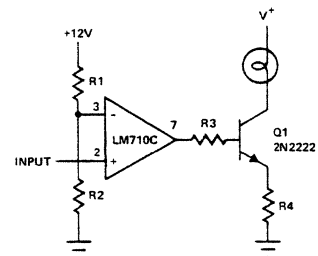

CONNECTION DIAGRAMS

Metal Can

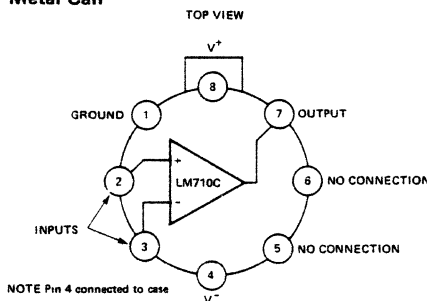

USED ON BOARDS: A10 U25, U35

NOTE: THIS INFORMATION IS FOR TRAINING PURPOSES ONLY.

LM307

(HP 1820-0493)

**OPERATIONAL AMPLIFIER
GENERAL DESCRIPTION**

The LM307 is a complete, general purpose operational amplifier, with the necessary frequency compensation built into the chip.

In addition to reduced input current, the offset voltage and offset current are guaranteed over the entire common mode range and maximum drift specifications are given. The amplifier also offers many features which make its appli-

cation nearly foolproof: overload protection on the input and output, no latch-up when the common mode range is exceeded, as well as freedom from oscillations. The low input currents also make it particularly well suited for long interval integrators or timers, sample and hold circuits and low frequency waveform generators.

TYPICAL APPLICATIONS

Inverting Amplifier

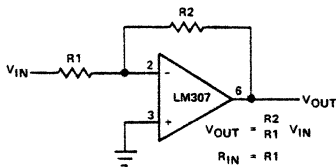

Non-Inverting Amplifier

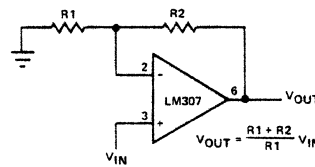

CONNECTION DIAGRAMS

Cavity Dual-In-Line Package

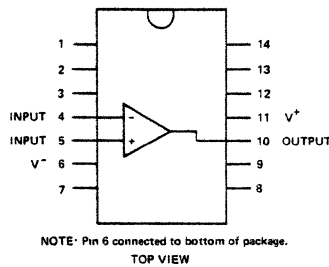

USED ON BOARDS: A12 U1, 2, 7, 9, 11, 12

NOTE: THIS INFORMATION IS FOR TRAINING PURPOSES ONLY.

9383/5483,7483

(HP 1820-0305)

4-BIT FULL ADDER

DESCRIPTION. The 9383/5483, 7483 full adder performs the addition of two 4-bit binary numbers. The sum (Σ) outputs are provided for each bit and the resultant carry (C) is obtained from the fourth bit. Designed for medium-to-high-speed, multiple-bit, parallel-add/serial-carry applications, the circuit utilizes high-speed high fan-out transistor-transistor logic (TTL) but is compatible

with both DTL and TTL families. The implementation of a single-inversion, high-speed, Darlington-connected serial-carry circuit within each bit minimizes the necessity for extensive "look-ahead" and carry-cascading circuits.

TYPICAL APPLICATIONS

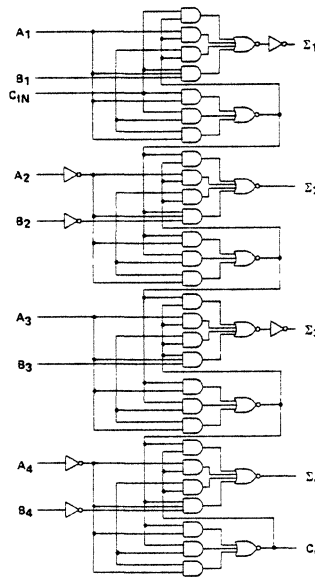

CONNECTION DIAGRAMS

V_{CC} = PIN 5
 GND = PIN 12

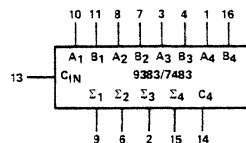

PIN NAMES

A1, B1, A3, B3
 A2, B2, A4, B4
 C_{IN}
 $\Sigma_1, \Sigma_2, \Sigma_3, \Sigma_4$
 C₄

Data Inputs
 Data Inputs
 Carry Input
 Sum Outputs
 Carry Out Bit 4

USED ON BOARDS: A11 U32, U35

NOTE: THIS INFORMATION IS FOR TRAINING PURPOSES ONLY.

(HP 1820-0515)

9602 MONOSTABLE MULTIVIBRATORS (1-SHOTS)

DESCRIPTION. The 9602 is a DC level sensitive retriggerable monostable multivibrator which provides an output pulse whose duration and accuracy is a function of external timing components.

The inputs are D.C. coupled making triggering independent of input transition times. If the input signal is applied to an active high input, triggering will occur on the rising edge of the waveform. By applying the input signal to an active low input, triggering will occur on the falling edge of the waveform.

The input conditions to be satisfied for triggering are indicated by the external logic symbols.

Each time the input conditions for triggering are met, the external capacitor is discharged and a new cycle is started. Successive inputs with a period shorter than the delay time trigger the monostable resulting in a continuous true output. Retriggling may be inhibited by tying the negation (\overline{Q}) output back to an active level low input.

The 9602 has an active low reset inputs (\overline{CD}) which allow the one shot to be reset.

TYPICAL APPLICATIONS

**9602 Dual
Retriggerable,
Resettable**

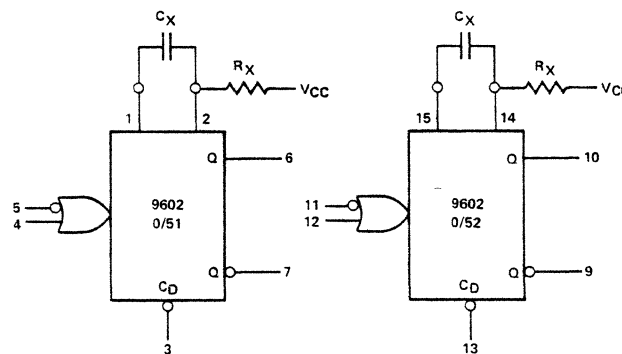

CONNECTION DIAGRAMS

USED ON BOARDS: A8 and A9

NOTE: THIS INFORMATION IS FOR TRAINING PURPOSES ONLY.

LM301A

(HP 1820-0477)

OPERATIONAL AMPLIFIER
GENERAL DESCRIPTION

The LM301A is a general-purpose operational amplifier which features improved performance over the 709C and other popular amplifiers.

The low input currents make it particularly well suited for long interval integrators or timers, sample and hold circuits and low frequency waveform generators.

In addition, the circuit can be used as a comparator with differential inputs up to $\pm 30V$; and the output can be clamped at any logic circuits.

TYPICAL APPLICATIONS

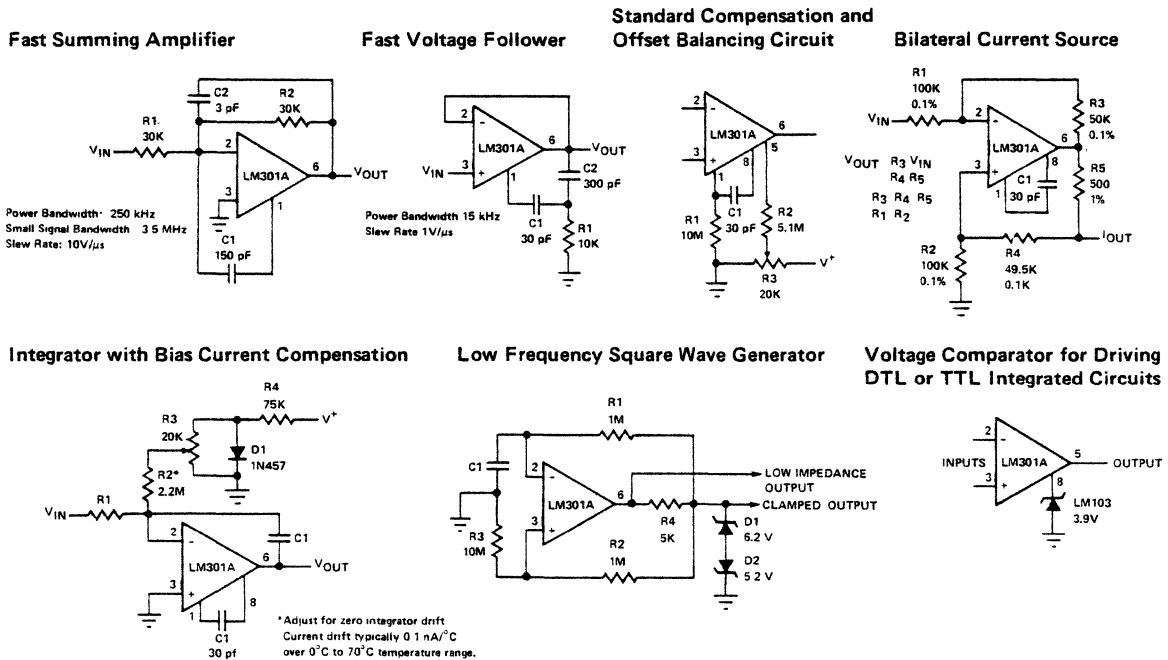

CONNECTION DIAGRAMS

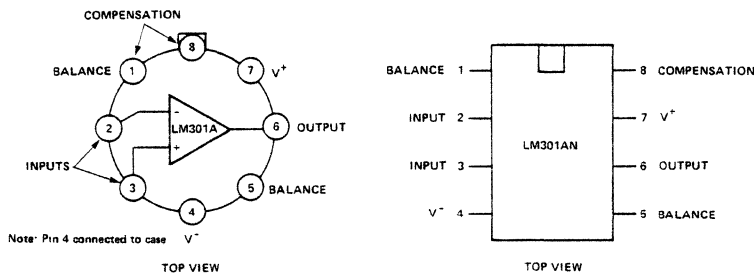

USED ON BOARDS: A2 U3, U4 ; A9 U30 ; A11 U31 ; A12 U14

NOTE: THIS INFORMATION IS FOR TRAINING PURPOSES ONLY.

HP 1820-0192

(HP 1820-0192)

TYPICAL APPLICATIONS

CHARACTERISTIC NUMBER	INPUT LEVEL		OUTPUT LEVEL		OPEN INPUT ACTS AS	PROPAGATION DELAY	
	LOGIC 1 (VOLTS MIN)	LOGIC 0 (VOLTS MAX)	LOGIC 1 (VOLTS MIN)	LOGIC 0 (VOLTS MAX)		TO LOGIC 1 (NS)	TO LOGIC 0 (NS)
62	2.0	0.9	2.5	0.4	—	12	15

CONNECTION DIAGRAMS

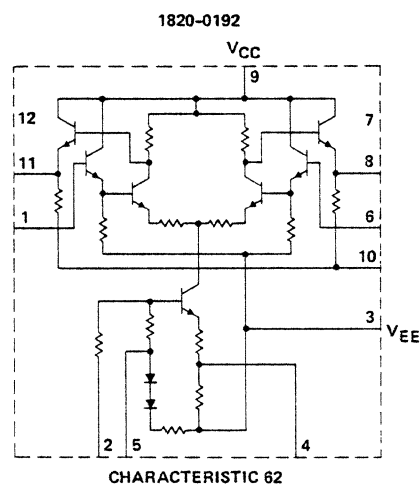

USED ON BOARDS: A13 U2

NOTE: THIS INFORMATION IS FOR TRAINING PURPOSES ONLY.

S E R V I C E N O T E

HP 7900A-1A SUPERSEDES:

HP 7900A DISC DRIVE
RECOMMENDED SPARE PARTS

The attached list provides spare parts provisioning guidelines for the HP 7900A cartridge disc drive.

The list is divided into three quantity levels:

- Level I Electrical and Mechanical components most frequently replaced.
- Level II Printed circuit boards and replaceable modules.
- Level III All items included in Level I and II, plus some additional high cost, or low failure rate parts and subassemblies. This level is recommended for support of isolated units or depot level maintenance.

The parts are listed in ascending numerical order by HP stock number. Manufacturer code and part number are supplied for purchasing convenience.

GF/tj/wn

11/71-42



HP PART NUMBER	DESCRIPTION	LEVEL 1	LEVEL 2	LEVEL 3	MFR CODE	MFR PART NUMBER
1854-0072	TSTR: SI NPN	2	0	2	80131	2N3054
1854-0215	TSTR: SI NPN	3	0	3	80131	2N3904
1854-0518	TSTR: SI NPN (SELECTED FROM 2N5877)	2	0	2	28480	1854-0518
1854-0519	TSTR: SI NPN (SELECTED FROM 2N3772)	2	0	2	28480	1854-0519
1855-0052	TSTR: FET	2	0	2	80131	2N4360
1855-0056	TSTR: FET	2	0	2	07263	2N4342
1855-0078	TSTR: FET SI	2	0	2	28480	1855-0078
1884-0012	RECTIFIER: SC	2	0	2	02735	2N3528
1884-0055	THYRISTOR: TRIAC 200V	2	0	2	86684	40529
1884-0076	THYRISTOR: TRIAC 400V	2	0	2	86684	40430
1884-0088	THYRISTOR: SCR 200V	2	0	2	86684	2N3228
1901-0026	DIODE: SI 0.75A 200 PIV	2	0	2	04713	SR1358-8
1901-0040	DIODE: SI 30 MA 30 WV	4	0	4	07263	FDG1088
1901-0044	DIODE: SI 20MA/1V	2	0	2	28480	1901-0044
1901-0049	DIODE: SI 0.75A 50 PIV	2	0	2	04713	SR 1358-6
1901-0416	DIODE: SI 30 MA 3A 200 PIV	2	0	2	28480	1901-0416
1901-0418	DIODE: SI 3 AMP 400 PIV	2	0	2	04713	1N5000
1901-0460	DIODE: SI 3-LAYER	2	0	2	03508	STB 523
1902-0025	DIODE BREAKDOWN: 10.0V 5% 400MW	2	0	2	28480	1902-0025
1902-0041	DIODE BREAKDOWN: 5.11V 5%	2	0	2	04713	SZ10939-98
1902-0048	DIODE BREAKDOWN: 6.8V 5%	2	0	2	04713	SZ10939-134
1902-0049	DIODE BREAKDOWN: 6.19V 5%	2	0	2	04713	SZ10939-122
1902-3003	DIODE BREAKDOWN: 2.37V 2%	2	0	2	04713	SZ10939-3
1902-3036	DIODE BREAKDOWN: 3.16V 5%	2	0	2	04713	SZ10939-38
1902-3149	DIODE BREAKDOWN: 9.09V 5%	2	0	2	28480	1902-3149
1902-3205	DIODE BREAKDOWN: 15.0V 5%	2	0	2	28480	1902-3205
1902-3224	DIODE BREAKDOWN: 17.8V 5% 400MW	2	0	2	28480	1902-3224
1910-0016	DIODE: GE 100MA/0.85V 60 PIV	2	0	2	93332	D2361
1990-0085	PHOTO TRANSISTOR: 30V	2	0	2	07263	FPT-100
1990-0320	PHOTOCELL ASSY	2	0	2	28480	1990-0320
2100-2489	R: VAR FLM 5K OHM 10% LIN 1/2W	2	0	2	28480	2100-2489
2100-2514	R: VAR CERMET 20K OHM 10% LIN 1/2W	2	0	2	28480	2100-2514
2100-2517	R: VAR FLM 50K OHM 10% LIN 1/2W	2	0	2	28480	2100-2517
2100-2692	R: VAR CERMET 1 MEGOHM 20% TYPE V 1/2W	2	0	2	28480	2100-2692
2100-0303	FUSE: CARTRIDGE 2A 250V SLOW-BLOW	5	0	5	71400	MDX-2A
2100-0365	FUSE: 4A 250V SLOW-BLOW	5	0	5	71400	MDA-4A
2140-0094	LAMP: INCANDESCENT 5 VOLT	3	0	3	92966	7153
2140-0343	LAMP: INCANDESCENT 14V 0.8A	3	0	3	98978	330
2140-0361	LAMP: INCANDESCENT 5V 0.115A	3	0	3	71744	CM7-7118
3101-1051	SWITCH: TOGGLE SPDT ON-NONE-ON	1	0	1	27191	8908K507
3101-1607	SWITCH: SENSITIVE	1	0	1	28480	3101-1607
3101-1608	SWITCH: SENSITIVE	1	0	1	28480	3101-1608
3140-0762	MOTOR, BLOWER	0	0	1		
3140-0763	MOTOR, SPINDLE	0	0	1		
3150-0225	FILTER, ABSOLUTE	1	0	1		
9100-1623	COIL/CHOKE 27 UH 5%	1	0	1	28480	9100-1623
9100-1627	COIL/CHOKE 39 UH 5%	1	0	1	82142	15-1315-2J
3160-0243	IMPELER, BLOWER	0	0	1		
4208-0037	FILTER, FRONT DOOR	1	0	1		

HP PART NUMBER	DESCRIPTION	LEVEL	LEVEL	LEVEL	MFR CODE	MFR PART NUMBER
		1	2	3		
07900-60001	HEAD (UP)	0	0	1	28480	07900-60001
07900-60004	HEAD (DOWN)	0	0	1	28480	07900-60004
07900-60006	READ/WRITE PREAMP PCA	0	1	1	28480	07900-60006
07900-60008	SECTOR COUNT PCA	0	1	1	28480	07900-60008
07900-60009	DRIVE CONTROL PCA	0	1	1	28480	07900-60009
07900-60011	READ-WRITE CONTROL PCA	0	1	1	28480	07900-60011
07900-60018	MOTOR POWER MODULE	0	1	1	28480	07900-60018
07900-60027	SECTOR TRANSDUCER ASSY.	0	1	1	28480	07900-60027
07900-60032	DISC ASSY. (LOWER)	0	0	1	28480	07900-60032
07900-60033	TERMINATOR PCA	0	1	1	28480	07900-60033
07900-60048	SERVO AMPLIFIER PCA	0	1	1	28480	07900-60048
07900-60051	INDICATOR PCA	0	1	1	28480	07900-60051
07900-60052	CYLINDER ADDR PCA	0	1	1	28480	07900-60052
07900-60053	ENCODER PCA	0	1	1	28480	07900-60053
07900-60056	DC INTERCONNECT PCA	0	1	1	28480	07900-60056
07900-60058	I/O MULTIPLEX PCA	0	1	1	28480	07900-60058
07900-60060	COIL LEAD ASSY.	0	0	1	28480	07900-60060

HP PART NUMBER	DESCRIPTION	LEVEL	LEVEL	LEVEL	MFR CODE	MFR PART NUMBER
		1	2	3		
0160-2055	C: FXD CER 0.01 UF +30-20% 100 VDCW	2	0	2	56289	C023F101F103ZS22-CDH
0180-0098	C: FXD TA ELECT 100 UF 20% 20 VDCW	1	0	1	56289	150D107X0020S2-DYS
0180-0100	C: FXD TA ELECT 4.7 UF 10% 35 VDCW	1	0	1	56289	150D475X9035B2-DYS
0180-0113	C: FXD TA ELECT 100 UF +20 - 15% 30 VDCW	1	0	1	56289	109D107C2030T2-DYP
0180-0116	C: FXD TA ELECT 6.8 UF 10% 35 VDCW	1	0	1	56289	150D685X9035B2-DYS
0180-0136	C: FXD ELECT 10 UF +100 - 10% 50 VDCW	1	0	1	56289	40D106F050DC4M1
0180-0141	C: FXD ELECT 50 UF +75 - 10% 50 VDCW	1	0	1	56289	30D506G050DD2-DSM
0180-0228	C: FXD ELECT 22 UF 10% 15 VDCW	1	0	1	56289	150D226X9015B2-DYS
0180-0229	C: FXD TA ELECT 33 UF 10% 10 VDCW	1	0	1	56289	150D336X9015B2-DYS
0180-0387	C: FXD TA ELECT 47 UF 5% 20 VDCW	1	0	1	28480	0180-0387
0180-1746	C: FXD TA ELECT 15 UF 10% 20 VDCW	1	0	1	28480	0180-1746
0683-2205	R: FXD COMP 22 OHM 5% 1/4W	1	0	1	01121	CB 2205
0686-1015	R: FXD COMP 100 OHM 5% 1/2W	1	0	1	01121	EB 1015
0686-1025	R: FXD COMP 1K OHM 5% 1/2W	1	0	1	01121	EB 1025
0686-2225	R: FXD COMP 2.2K OHM 5% 1/2W	1	0	1	01121	EB 2225
0698-0084	R: FXD MET FLM 2.15K OHM 1% 1/8W	1	0	1	28480	0698-0084
0698-3132	R: FXD FLM 261 OHM 1% 1/8W	1	0	1	28480	0698-3132
0698-3136	R: FXD MET FLM 17.8K OHM 1% 1/8W	1	0	1	28480	0698-3136
0698-3150	R: FXD MET FLM 2.37K OHM 1% 1/8W	1	0	1	28480	0698-3150
0698-3155	R: FXD MET FLM 4.64K OHM 1% 1/8W	1	0	1	28480	0698-3155
0698-3157	R: FXD MET FLM 19.6K OHM 1% 1/8W	1	0	1	28480	0698-3157
0698-3159	R: FXD MET FLM 26.1K OHM 1% 1/8W	1	0	1	28480	0698-3159
0698-3160	R: FXD MET FLM 31.6K OHM 1% 1/8W	1	0	1	28480	0698-3160
0698-3162	R: FXD MET FLM 46.4K OHM 1% 1/8W	1	0	1	28480	0698-3162
0698-3435	R: FXD MET FLM 38.3 OHM 1% 1/8W	1	0	1	28480	0698-3435
0698-3437	R: FXD MET FLM 133 OHM 1% 1/8W	1	0	1	28480	0698-3437
0698-3439	R: FXD MET FLM 178 OHM 1% 1/8W	1	0	1	28480	0698-3439
0698-3440	R: FXD MET FLM 196 OHM 1% 1/8W	1	0	1	28480	0698-3440
0698-3441	R: FXD MET FLM 215 OHM 1% 1/8W	1	0	1	28480	0698-3441
0698-3443	R: FXD MET FLM 287 OHM 1% 1/8W	1	0	1	28480	0698-3443
0698-3444	R: FXD MET FLM 316 OHM 1% 1/8W	2	0	2	28480	0698-3444
0698-3446	R: FXD MET FLM 383 OHM 1% 1/8W	1	0	1	28480	0698-3446
0698-3451	R: FXD MET FLM 133K OHM 1% 1/8W	1	0	1	28480	0698-3451
0698-3452	R: FXD MET FLM 147K OHM 1% 1/8W	1	0	1	28480	0698-3452
0698-3456	R: FXD MET FLM 287K OHM 1% 1/8W	1	0	1	28480	0698-3456
0698-3457	R: FXD MET FLM 316K OHM 1% 1/8W	1	0	1	28480	0698-3457
0698-3460	R: FXD MET FLM 422K OHM 1% 1/8W	1	0	1	28480	0698-3460
0757-0123	R: FXD MET FLM 34.8 OHM 1% 1/8W	1	0	1	28480	0757-0123
0757-0198	R: FXD MET FLM 100 OHM 1% 1/2W	1	0	1	28480	0757-0198
0757-0279	R: FXD MET FLM 3.16K OHM 1% 1/8W	1	0	1	28480	0757-0279
0757-0280	R: FXD MET FLM 1.0K OHM 1% 1/8W	1	0	1	28480	0757-0280
0757-0288	R: FXD MET FLM 9.09K OHM 1% 1/8W	1	0	1	28480	0757-0288
0757-0289	R: FXD MET FLM 13.3K OHM 1% 1/8W	1	0	1	28480	0757-0289
0757-0290	R: FXD MET FLM 6.19K OHM 1% 1/8W	1	0	1	28480	0757-0290
0757-0401	R: FXD MET FLM 100 OHM 1% 1/8W	1	0	1	28480	0757-0401
0757-0403	R: FXD MET FLM 121 OHM 1% 1/8W	1	0	1	28480	0757-0403
0757-0416	R: FXD MET FLM 511 OHM 1% 1/8W	1	0	1	28480	0757-0416
0757-0418	R: FXD MET FLM 619 OHM 1% 1/8W	1	0	1	28480	0757-0418
0757-0420	R: FXD MET FLM 750 OHM 1% 1/8W	2	0	2	28480	0757-0420
0757-0438	R: FXD MET FLM 5.11K OHM 1% 1/8W	1	0	1	28480	0757-0438
0757-0441	R: FXD MET FLM 8.25K OHM 1% 1/8W	1	0	1	28480	0757-0441
0757-0442	R: FXD MET FLM 10.0K OHM 1% 1/8W	1	0	1	28480	0757-0442
0757-0447	R: FXD MET FLM 16.2K OHM 1% 1/8W	1	0	1	28480	0757-0447
0757-0449	R: FXD FLM 20K OHM 1% 1/8W	1	0	1	28480	0757-0449
0757-0458	R: FXD MET FLM 51.1K OHM 1% 1/8W	1	0	1	28480	0757-0458

HP PART NUMBER	DESCRIPTION	LEVEL	LEVEL	LEVEL	MFR CODE	MFR PART NUMBER
		1	2	3		
0757-0462	R: FXD MET FLM 75K OHM 1% 1/8W	1	0	1	28480	0757-0462
0757-0465	R: FXD MET FLM 10K OHM 1% 1/8W	1	0	1	28480	0757-0465
0757-0799	R: FXD MET FLM 121 OHM 1% 1/2W	1	0	1	28480	0757-0799
0761-0008	R: FXD MET OX 510 OHM 5% 1W	1	0	1	28480	0761-0008
0764-0044	R: FXD MET OX 3.2K OHM 5% 2W	1	0	1	28480	0764-0044
0811-1666	R: FXD WW 1.0 OHM 5% 2W	1	0	1	28480	0811-1666
0811-2490	R: FXD WW 0.1 OHM 3% 5W	1	0	1	28480	0811-2490
0811-3039	R: FXD WW 0.1 OHM 5% 10W	1	0	1	28480	0811-3039
0812-0060	R: FXD WW 5K OHM 5% 5W	1	0	1	28480	0812-0060
1000-0276	ENCODER: PLATE	1	0	1	28480	1000-0276
1420-0088	BATTERY, NICAD	0	0	4	05397	CH500
1500-0300	DRIVE BELT: 50 HZ	1	0	1	28480	1500-0300
1500-0301	DRIVE BELT: 60 HZ	1	0	1	28480	1500-0301
1820-0054	IC: TTL QUAD 2-INPT NAND GATE	1	0	1	01295	SN4342
1820-0068	IC: TTL TRIPLE 3-INPT POS NAND GATE	1	0	1	12040	SN7410N
1820-0069	IC: TTL DUAL 4-INPT POS NAND GATE	1	0	1	01295	SN4344
1820-0077	IC: TTL DUAL D F/F (LATCH)	1	0	1	01295	SN4354
1820-0099	IC: DIGITAL	1	0	1	01295	SN7493N
1820-0141	IC: TTL QUAD	1	0	1	28480	1820-0141
1820-0174	IC: TTL HEX INVERTER	1	0	1	01295	SN8199
1820-0175	IC: TTL HEX CONVERTER	1	0	1	01295	SN8200
1820-0192	IC: VIDEO AND WIRE BAND AMPLIFIER	2	0	2	28480	1820-0192
1820-0207	IC: TTL MONOSTABLE MULTIVIBRATOR	2	0	2	07263	SL 12895
1820-0233	IC: TTL UP-DOWN 4-BIT BINARY COUNTER	2	0	2	01295	SN10625
1820-0239	IC: TTL QUAD 2-INPT NOR GATE	2	0	2	04713	MC 3002P
1820-0250	IC: TTL 6-BIT COMP	2	0	2	28480	1820-0250
1820-0269	IC: DIGITAL QUAD 2-INPT NAND GATE	2	0	2	01295	SN12785
1820-0282	IC: TTL 2-INPT OR GATE	2	0	2	01295	SN13603
1820-0301	IC: TTL QUAD LATCH BUFF STORAGE	2	0	2	01295	SN4463
1820-0305	IC: BINARY FULL ADDER	2	0	2	01295	SN7483N
1820-0398	IC: LINEAR	2	0	2	01295	SN72710N
1820-0477	IC: LINEAR OPERATIONAL AMPLIFIER	2	0	2	28480	1820-0477
1820-0493	IC: LINEAR	2	0	2		LM307N
1820-0511	IC: TTL QUAD 2-INPT AND GATE	2	0	2	01295	SN20572
1820-0515	IC: TTL + LOGIC	2	0	2	07263	SL50099
1820-0535	IC: DIGITAL	2	0	2	28480	1820-0535
1820-0537	IC: TTL DUAL 4-INPT NAND GATE	2	0	2	01295	SN7413N
1820-0577	IC: TTL DIGITAL HEX INVERTER	2	0	2	01295	SN22729
1820-0722	IC: DIGITAL	2	0	2	28480	1820-0722
1820-0723	IC: DIGITAL	2	0	2	28480	1820-0723
1826-0040	IC: LINEAR VIDEO AMPLIFIER	2	0	2	28480	1826-0040
1826-0041	ID: LINEAR ZERO VOLTAGE SWITCH	2	0	2	02735	CA3059
1853-0010	TSTR: SI PNP (SELECTED FROM 2N3251)	2	0	2	28480	1853-0010
1853-0012	TSTR: SI PNP	2	0	2	80131	2N2904A
1853-0020	TSTR: SI PNP (SELECTED FROM 2N3702)	2	0	2	28480	1853-0020
1853-0036	TSTR: SI PNP	2	0	2	80131	2N3906
1853-0305	TSTR: SI PNP	2	0	2	80131	2N5875
1854-0019	TSTR: SI NPN (SELECTED FROM 2N2369)	2	0	2	28480	1854-0019
1854-0039	TSTR: SI NPN	2	0	2	80131	2N3053
1854-0045	TSTR: SI NPN	2	0	2	04713	2N956
1854-0053	TSTR: SI NPN	2	0	2	80131	2N2218
1854-0071	TSTR: SI NPN (SELECTED FROM 2N3704)	2	0	2	28480	1854-0071

S E R V I C E N O T E

HP 7900A-2b SUPERSEDES:

HP 7900A DISC DRIVE

TOOLS, TEST EQUIPMENT AND MAINTENANCE SUPPLIES

Listed below are the Tools, Test Equipment and Maintenance supplies required for maintaining, aligning and repairing the HP 7900A Disc Drive:

OSCILLOSCOPE SET, AS FOLLOWS OR EQUIVALENT:

HP 180A	Oscilloscope	1 each
HP 1801A	Dual Chan. Vertical Amp.	1 each
HP 1821A	Time Base	1 each
HP 10006A	Probe, 10:1	3 each

DIGITAL VOLTMETER SET, AS FOLLOWS OR EQUIVALENT:

HP 3469B	Digital Voltmeter	1 each
----------	-------------------	--------

DISC SERVICE UNIT:

HP 13219A	Service Unit	1 each
Head Cleaning Tool	07900-00091	1 each
Extender Board	07900-60014	1 each
Head Adjustment Tool	07900-60044	1 each
Alignment Cartridge	1535-2531 or 1535-0066	1 each
Mylar Feeler Gauge 0.005"	1535-0648	1 each
Filtered Alcohol (6 oz.)	1535-1432	1 each
Lint Free Tissue (Kimwipe)	9300-0001	1 each

(Continued)

BG/lm/WN

3/73-22

HEWLETT **hp** **PACKARD**

STANDARD TOOLS:

Posi Drive Screwdriver	(Stanley 2951)
Posi Drive Screwdriver	(Stanley 2952)
Long Nose Pliers	(Xcelite 71CG)
Wire Cutters	(Xcelite 74CG)
Screwdriver 4" x 1/4"	(Xcelite R-144)
Screwdriver 4" x 1/8"	(Xcelite R-184)
Wire Stripper	(K-Miller 101-S)
6" Steel Rule	(General 616)
Soldering Iron	(Ungar 6010)
Inspection Iron	(G.C. Elect. 5090-P)
IC Pin Clip	(A-P Inc.)
Socket Keys	(Xcelite 99PS-40)

S E R V I C E N O T E

SUPERSEDES:

7900A DISC SYSTEM
INSTALLATION PROCEDURES

This service note contains important information to facilitate installation of the 7900A Disc Drive and associated equipment at end-user customer sites. Reference is made to other readily available documents which have been provided or which accompany the disc system.

This device must be installed by HP trained personnel who are familiar with proper installation and service techniques. If the system is damaged as a result of installation by unauthorized personnel, the warranty will be void.

A complete 7900A Disc System is comprised of a 13210A Interface Kit, one to four 7900A Disc Drives and a 13215A Power Supply for each drive. This Service Note is intended to assist in installing such a system in a HP 2940A Cabinet.

The following materials will be received when a complete system is installed:

13210A Interface Kit:

- 13210-60000 DISC 2 Interface Board
- 13210-60004 DISC 1 Interface Board
- 13210-60003 Interface Cable
- 13210-90003 Operating and Service Manual
- 13041-60001 Diagnostic Tape
- 13210-90004 Diagnostic Manual

BG /Im /wn

(Continued)

5/72-42



Installation Procedures

7900A Disc Unit:

9164-0045	24 Sector Cartridge
07900-90002	Disc Operating and Service Manual
07900-60033	Termination P.C. Board
07900-60034	Multi Unit Cable (Required if two or more drives are installed)
13215A	Power Supply
13215-60011	Power Supply Rack Mounting Kit
13215-90003	Power Supply Operating and Service Manual
07900-60066	Disc Unit Rack Slide Mounting Kit

Remove all packing materials, straps, etc. Inspect all equipment thoroughly for dents, scratches, etc., which may have occurred during shipment. Report any damage to the carrier and the nearest HP Sales Office immediately.

---CAUTION---

Dangerous voltages are present in the system which require application of standard safety precautions.

Special tools and equipment are required to install the 7900A Disc System. These tools are described in Service Note 7900A-2.

To install the 7900A Disc System, perform the following steps in sequence:

Refer to Section II of the 7900A Operating and Service Manual for additional information.

1. Install the mounting kit in the 2940A Cabinet.
2. Mount the slide on the 7900A drive.
3. Extend the slide racks and install the 7900A Drive in the cabinet.

Refer to Section II of the 13215A Power Supply Manual for additional installation information.

1. Insure that TB1 of the power supply is wired for the proper primary power source. Refer to Figure 4 of this note and Section II of the 13215A Manual.

(Continued)

Installation Procedures

2. Mount the 13215-60011 Rack Mounting Kit as described in the 13215A Manual. Mount the 13215A Power Supply. Insure that there is no electric continuity between the power supply and the 2940A Cabinet.
3. Connect primary power to the power supply and check the supply voltages below:

---NOTE---

If this unit is to be connected to any power source other than 110-120VAC, 60 Hz, a power cable plug must be locally purchased to meet requirements.

TB2-1	Ground
TB2-3	+5 VDC \pm 5%
TB2-4	-12 VDC \pm 5%
TB2-5	+12 VDC \pm 5%
TB2-7	+24 VDC \pm 10%
TB2-8	-24 VDC \pm 10%

Remove primary power.

4. If all voltages are within specifications, connect the AC/DC power cables between the 13215A and the 7900A drive. Refer to 13215-90003 Power Supply Operating and Service Manual.
5. Check to insure that there is no electrical continuity between the 7900A chassis and the 2940A cabinet.

Refer to Section II of the 7900A Operating and Service Manual.

1. Extend the drive on its slides and remove the top cover. Remove the carriage shipping detent to allow carriage motion. The carriage shipping detent should be saved for future use in the event the equipment is relocated. See Figure 1.

(Continued)

Installation Procedures

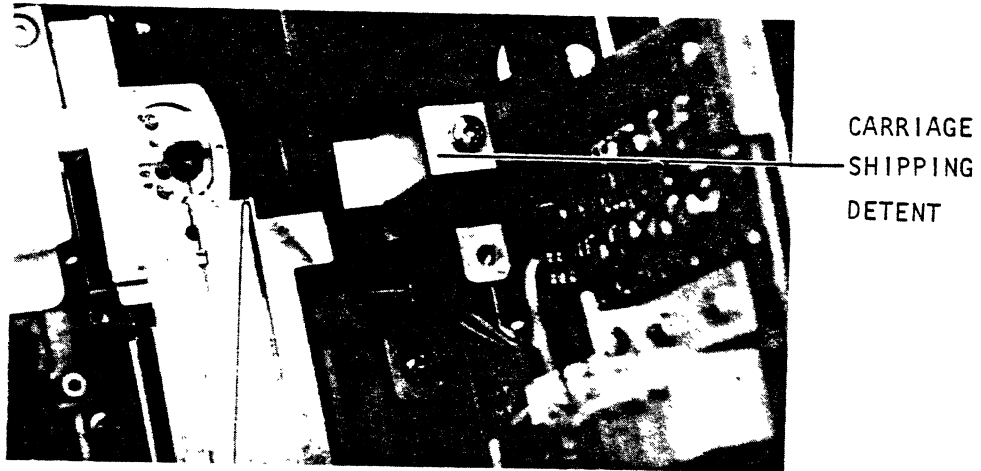

Figure 1

2. To insure proper cartridge seating, clean any foreign material from the spindle magnet.
3. Check the drive alignment as specified in Section V of the Operating and Service Manual. Insure that the following adjustments are within the required specifications:

Encoder Alignment

Servo Adjustment

NOTE: Check Access time for $> 52 < 55$ MSEC.

4. To ensure cartridge interchangeability, check the following adjustments:

Head Alignment

Sector Circumferential

Refer to Section II of the 13210A Operation and Service Manual.

1. Install the disc interface P.C. Boards in the desired I/O select code slots in the computer. The DISC 1 interface board will be installed in the high priority (lower numbered) I/O slot.

(Continued)

Installation Procedures

---NOTE---

If the interface kit is being installed in a 2116A, Resistor R-22 on the DISC 1 board must be desoldered and moved to the empty connection pad (+5V) between R22 and C-16. Refer to Figure 4-1 (parts location) and the schematic diagram (grid location D-8) in the 13210A Operating and Service Manual.

2. Connect the interface cable between the interface boards and the A-17 P.C.A. receptacle on the back of the drive.
3. Install the termination P.C. Board in the A-16/A-20 P.C.A. receptacle on the back of the drive. Refer to Figure 5-13 of the Operating and Service Manual and Figure 3 of this note.
4. If more than one drive is to be connected to the interface, a multi-unit cable must be used to daisy chain the drives together. This cable should be connected between the A-16/A-20 P.C.A. receptacle (in place of the terminator) to the A-17 receptacle of the daisy chained drive. The terminator P.C.A. must be installed in the last unit on line.
5. Insure that the correct DRIVE SELECT and ATTENTION address jumpers are installed. Jumper coding is described on the I/O multiplex board (A-7) schematic.

---NOTE---

Insure that no two drives have the same select address.

Refer to the 7900/13210 Diagnostic Manual for operating instructions and failure analysis.

1. Install a spare cartridge and load the drive being installed.

(Continued)

Installation Procedures

May, 1972

2. Use the diagnostic program to initialize both the upper and lower disc.

This may be accomplished as follows:

Set both DATA PROTECT switches OFF. Set the PROTECT/OVERRIDE switch (located behind coarse filter screen) to OVERRIDE. Use the operator design section (S-7) of the diagnostic and execute the following instructions:

```
SD,X
LB,AA
IS          (Select Head 0)
ID
IS, ,2     (Select Head 2)
ID
RT,AA,202  (Loop 202 Times)
HT,777     (Hlt, display 7778)
EN
```

3. Verify proper operation of the drive (upper and lower disc) by running the complete diagnostic program.

S E R V I C E N O T E

7900A-4 SUPERSEDES:

7900A DISC DRIVE
HEAD-DISC INTERFERENCEGENERAL

Head-Disc Interference (frequently referred to as a head crash) is a result of unwanted head contact with the disc surface. Head-Disc Interference (HDI) is most commonly caused by a build-up of dirt on the Read/Write Head or a foreign particle in the air stream between the head and disc surface. If HDI occurs, it must be TOTALLY corrected before normal operation is resumed or reoccurrence is likely.

RECOGNITION

HDI can usually be recognized by one or more of the following symptoms:

- A. Repetitive hard read errors from a drive that previously operated properly.
- B. Uncommon noise from the drive. This noise may be recognized as anything from a "tinkling" sound to a constant "screech".
- C. Read/Write Head damage such as streaks of oxide on the ceramic. A small amount of oxide on the leading edge of the ceramic shoe is not uncommon but should not be allowed to build up.
- D. Disc surface damage. This may appear as anything from gross concentric scratches to small "dings" in the oxide.

In the event of HDI or if HDI is suspected, do not move the cartridge to another drive. Moving the cartridge is very likely to propagate the head crash.

GF/tj/wn

(Continued)

10/71-42



Head-Disc Interference

CORRECTION

To recover from HDI, the following procedure should be followed:

- A. Remove the damaged disc and clearly mark it as unusable.
- B. Remove the damaged heads. When a head "crashes", oxide is frequently broken loose from the disc surface. This contaminates the entire disc area. Consequently, both heads associated with the damaged disc are sometimes destroyed.
- C. Inspect the heads very carefully. If any damage (even very minor scratches) exist, remove the head from service.
- D. Attempt to determine the cause of the crash. Keep in mind that the head "flies" approximately 100 microinches above the disc surface. This means that any foreign material in the head area can initiate a crash that may become progressively worse.
- E. Correct the cause of the crash and clean any undamaged head in accordance with the drive Operating and Service Manual. DO NOT attempt to repair a head assembly or disc surface.
- F. Restore the drive to operational status and initialize the new disc.
- G. Report the incident to the Mountain View Division Service Engineering Group via TWX or telephone.

HDI PREVENTION

The possibility of HDI can be minimized through good preventive maintenance and operating procedures. The main points of these procedures are:

- A. Inspect the heads every 60-90 days and clean as required.
- B. Keep the front door filter clean.
- C. Replace the absolute filter every year or sooner if required.
- D. Perform cleaning routines as described in the drive Operating and Service Manual.
- E. Keep the covers on the drive and the front door closed whenever possible.
- F. Store the cartridge on edge in a clean area.
- G. Do not store a cartridge in the drive.
- H. Allow the cartridge time to attain room temperature before installing it in the drive.
- I. Operate the drive in as clean an environment as possible.

S E R V I C E N O T E

7900A-5a SUPERSEDES:

7900A DISC DRIVE

Drive Fault or Intermittent Read Errors

Two engineering changes should be incorporated in preamp PCA Part No. 07900-60006 and 07900-60039 Series 1145 and Below. Change I is designed to correct a possible multi-head select error caused by diode breakdown. This change is for preamp boards Series 1149 and below. These boards were shipped in drives with serial prefix 1202A and Below. Change II will eliminate intermittent read/write errors caused by the excessive decrease of write current beyond track 128. This change should be incorporated in boards Series 1127. These boards were shipped in drives with serial prefix 1143A and below.

CHANGE I

<u>Qty</u>	<u>Description</u>	<u>HP Part Number</u>	<u>Ref Designator</u>
2	Res. Fix MF 14.7K 1/8W 1%	0698-3156	R51, 52
19	Diode 30V 30MA	1901-0450	CR3-6, 9-22,24
1	Label PC Assy	7124-2099	
1	Label, Disc Drive	7120-0134	

IMPLEMENTATION

Refer to the Operating and Service Manual to gain access to the preamp assembly and for the location of the above components.

Replace the old components with the ones supplied and change the ID tag on preamp board to read 1205. Install the preamp in the 7900A disc drive and verify proper operation. Change the date code serial number on the disc drive to 1205A-XXXXX.

BG/lm/WO

(Continued)

4/72-42



Possible symptoms if new components are not in preamp:

1. Drive fault with a multihead select (octal code 7 TP 2, 3 and 4 of A10 assembly) are true.
2. Drive fault with an erase gate no erase current (octal code 1 TP 3 of A10 assembly) is true.
3. Address Error while running diagnostic with status print out of E21, and E22, due to the inability of the preamp to detect sync "1" word.

CHANGE 11

<u>Qty</u>	<u>Description</u>	<u>HP Part Number</u>	<u>Ref Designator</u>
1	Res. Fix 619 ohm 1/8W	0757-0422	R35
2	Trans	1854-0260	Q10 and 14

IMPLEMENTATION

Refer to 7900A Operating and Service Manual to gain access to the preamp assembly and for location of components. Replace the old components with the ones described above. Install the preamp PCA and verify proper operation.

S E R V I C E N O T E

HP 7900A-6 SUPERSEDES:

None

HP 7900A DISC DRIVE
 Serial No. Prefix 1205A & Below
 ENCODER P.C.A. HP P/N 07900-60053

Two changes have been made to Encoder P.C.A. (A12) to improve reliability. The first change eliminates an intermittent "Drive Busy" status (00005) while running the diagnostic or in some software, a "Drive Not Ready" status. The bad status is the result of reaching the desired new cylinder, momentarily gating "Access Ready", then overshooting the cylinder and dropping "Access Ready." The Diagnostic (or other software) receives the initial Access Ready and proceeds. Meanwhile, the drive overshoots and the CPU receives Drive Not Ready status from the interface.

The second change deletes the Velocity Gain adjustment. This adjustment was redundant and not necessary.

PARTS REQUIRED

<u>QTY</u>	<u>HP P/N</u>	<u>DESCRIPTION</u>	<u>REF DESIGNATOR</u>
1	0757-0465	Res.Fix.100K 1/4W 1%	R47
1	0683-2745	Res.Fix.270K 1/4W 5%	.59
1	0683-6835	Res.Fix. 68K 1/4W 5%	R65
1	7124-2099	Label P. C. A.	
1	7120-0134	Label, Drive	

BG/lm/WA

5/72-22



IMPLEMENTATION

1. Refer to the 7900A Operating and Service Manual and remove the Encoder P.C.A. (A12)
2. Replace R 59 with a 270K resistor. See Figure 1.
3. On the solder side of the board, attach a 68K Resistor between pins 3 and 6 of U14. See Figure 1.
4. See Figure 1. Delete R9 and R61. Replace R47 (90.9K) with a 100K Resistor.
5. On the circuit side, add a jumper between R47 and U7 pin 6. See Figure 1.
6. Type the PC label to read 07900-60053 Series 1213A.
7. Change the label on the drive to reflect series 1213-xxxxxx.
8. Align the disc drive using the attached Servo Adjustment Procedure.
9. Run the Disc Diagnostic and return the disc drive to normal operation.
10. Make the above changes in the Parts List and Schmetics of the Operating and Service manual and add the Servo Alignment procedure in the appropriate place in the manual.

5-39 Servo Adjustment

5-40 To adjust the Servo Amplifier; proceed as follows:

- a. Connect the Disc Service Unit to A6J1 on the disc Drive (Refer to the Disc Service Unit Operating and Service Manual.)
- b. Turn on power and place load switch in the load position.
- c. Set the **Reset Drive Fault** switch on the Disc Service Unit to on.
- d. Set the **ACCESS MODE** Switch on the Disc Service Unit to the **INCREMENTAL SEEK** position and the Drive Operation Control switch to **ALLOW ACCESS** mode. Push Run.
- e. Connect Oscilloscope to A. Channel Amplifier, A12TP5.
- f. Connect the SYNC probe to Access Ready on the Disc Service Unit.
- g. Adjust A Gain, A12 R8, so that the position waveform is 12 volts P to P.
- h. Center waveform with A Bal. A12 R1 until there are equal positive and negative excursions.

NOTE: The amplitude of the A Channel signal may vary between tracks. The waveform should never be less than 10 volts P. to P. on single track seek. However, the amplitude may be less than 10 volts or more than 12 volts on multitrack seek.

- i. Program the Disc Service Unit to alternately seek between cylinder 00 and 202.
- j. Connect the oscilloscope to the Access Ready test on the Disc Service Unit.
- k. Adjust VEL CMND Variable Resistor A11R36, such that the Access Ready Signal is low (0 volts) for a period > 52 and < 55 MSEC.
- l. Set the **DRIVE OPERATION CONTROL** on the Disc Service Unit to **ACCESS STOP**.
- m. Set the **LOAD** switch to off and remove drive power.

- n. Install spare cartridge and perform alternate seeks between cylinder 00 and 202 to ensure that disc drive is performing properly (Refer to Disc Service Unit Operating and Service Manual)

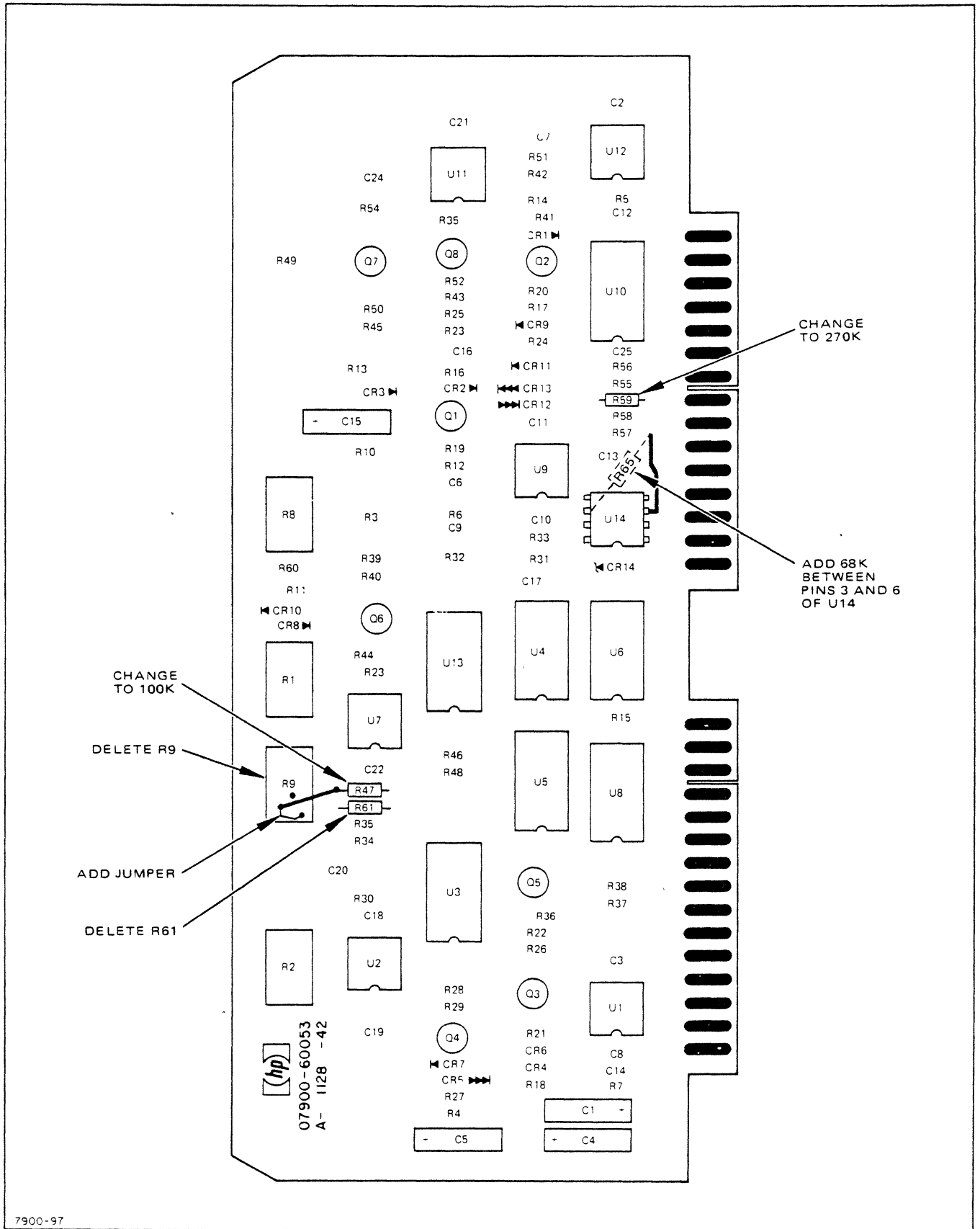

Figure 1 Encoder Assembly A12 Parts Location Diagram

S E R V I C E N O T E

7900-7 SUPERSEDES:

HP7900A Disc Drive

All Series

INCREASE TRICKLE CHARGE TO THE RETRACT BATTERIES

A change has been made to the HP 7900A Servo P.C.A. (A2) to increase the change current to the retract batteries. This change will ensure that the current to retract the carriage in the event of a power failure will be more than adequate.

PARTS REQUIRED

Qty	Description	HP P/N	Ref
1	Res. Fix 1.5K 1 W 5%	0761-0015	R77
1	PC Label		

IMPLEMENTATION

1. Refer to the 7900 Operating and Service Manual to gain access to the A2 P.C.A. and the location of R 77.
2. Clip the resistor leads next to the resistor and straighten the leads remaining on the board.
3. Attach 1.5K resistor to the leads remaining on the board.
4. Reassemble the disc drive and return it to normal operation.
5. Change the part No. Label to read Series 1223.
6. Make the above change in the 7900 Operating and Service Manual.

BG/lm/WN

5/72-22



S E R V I C E N O T E

7900A-8 SUPERSEDES:

HP7900 DISC DRIVES

Installing the Cartridge Receiver

When installing the cartridge receiver into the HP 7900A Disc Drive, care should be taken to prevent breaking the receiver holding clips on the Receiver Pivot Block. To prevent breaking, pull back the two receiver retaining tabs and insert the receiver.

Furthermore, the Receiver modesty shield (Rubber Flap) should be pushed back behind the exposed lip of the front casting. If this shield is not installed properly, the cartridge may not seal properly, and a possible head crash may result.

BG/lm/WN

22-9/72



S E R V I C E N O T E

7900A-9 SUPERSEDES:

HP 7900A DISC DRIVE

Encoder PCA PN 07900-60053 Prefix 1223 & Below

OPERATIONAL AMPLIFIER PART NO. CHANGE

In the event that Operational Amplifier U9 or U12 (HP P/N 1820-0493) fails, replace it with HP P/N 1826-0068. The old amplifier may not provide adequate frequency response. The new amplifier has been pre-tested by the vendor.

The questionable parts are in drives with serial prefixes 1232A and below.

IMPLEMENTATION

In the 7900 Operating and Service Manuals Parts List, replace U9 and U12 with HP P/N 1826-0068.

BG/lm/WN

10/72-22



S E R V I C E N O T E

7900A-10 SUPERSEDES:

HP 7900A CARTRIDGE DISC DRIVE

Serial No. Prefix 1236 and Below

MOTOR POWER MODULE REPLACEMENT

PN 07900-60041 EXCHANGE

A change has been made on the motor control P.C.A. (A15) of the motor power module. This change deletes the zero crossing detector. By removing the zero crossing detector, the spindle motor is no longer vulnerable to line transients and therefore will not normally heat up.

The motor power module is required on all 7900's used with the HP 3000. Also the new module has been UL approved. Thus to prevent any confusion on replacement in the field, turn in the old motor power modules (Exchange PN 07900-60041), which are in stock and spares kits for credit and order the new motor power module (Exchange PN 07900-60068).

NOTE: The new motor power module will work in all 7900's, but the old module with zero crossing detector will not work in new 7900's Serial No. Prefix 1245 and above.

BG/lm/WN

11/72-22

HEWLETT  PACKARD

For more information, call your local HP Sales Office or East (201) 265-5000 • Midwest (312) 677-0400 • South (404) 436-6181
West (213) 877-1282. Or, write: Hewlett-Packard, 1501 Page Mill Road, Palo Alto, California 94304. In Europe, 1217 Meyrin-Geneva

S E R V I C E N O T E

7900A-11 SUPERSEDES:

HP 7900A CARTRIDGE DISC DRIVE
PREVENTIVE MAINTENANCE SCHEDULE

Attached is a preventive maintenance schedule for the 7900A disc. The schedule in the manual has been revised to require absolute filter change every 6 months. In addition, it is now recommended that the lower disc assembly be cleaned at 6-month intervals.

To clean the lower disc, use the same cleaning techniques as those used when the disc is replaced in the field.

These are:

1. Remove the lower disc assembly.
2. Clean the recording surface using KimWipes and filtered 91% isopropyl alcohol. NOTE: While spinning the disc assembly, wipe the surfaces from the inside to the outside edge.
3. Replace the lower disc assembly.
4. Place disc back into operation.

NOTE

The importance of keeping the disc clean cannot be over emphasized. The attached is a minimum recommended P.M. schedule. However, various customer environments may require that the schedule be accelerated to prevent catastrophic failures.

BG/lm/WN

Page 1

11/72-22

HEWLETT  PACKARD

TIME INTERVAL

ITEM	2 MONTHS	6 MONTHS	1 YEAR
1. Heads	Clean with 91% filtered alcohol and KIMWIPES		
2. Carriage Rails	A. Clean with filtered alcohol and Q-tips. B. Inspect for bearing wear and ease of rotation.		
3. Encoder Plate	Clean with filtered alcohol and Q-tips.		
4. Spindle	A. Clean with masking tape by pressing sticky side to exposed surface. B. Inspect for bearing wear & ease of rotation.		
5. Linear Motor	Clean with masking tape by pressing sticky side to exposed portion of coil.		
6. Front Door Filter	Clean with vacuum cleaner.		
7. Absolute Filter	Inspect for contamination. Replace if dirty.	Unconditional replacement.	Unconditional replacement.
8. Casting and Receiver	Clean with alcohol and Kimwipes.		
9. Lower Disc Assembly		Remove and clean with alcohol and Kimwipes.	Remove and clean.
10. Belt	Inspect for wear and possible replacement.		
11. Static Discharge Contact	Inspect for looseness.		Unconditional replacement.
12. Power Supply	Check and adjust voltages if necessary.		
13. Alignment	Check and adjust if necessary.		

S E R V I C E N O T E

7900A-12 SUPERSEDES:

HP 7900A Cartridge Disc Drive

All Serial Numbers

OPERATOR PRECAUTION

System operators should use caution when inserting a cartridge into a 7900 Disc Drive. If the cartridge is inserted with force, head Zero may be knocked out of alignment. Thus, please insert the cartridge slowly.

What actually takes place when inserting the cartridge with force is just prior to the cartridge seating home in the receiver, the recording platter floats free. The forward momentum of the free floating platter carries it into the holding arm of head Zero. Thus knocking head Zero out of alignment.

Again please insert the cartridge slowly into the 7900 Disc Drive.

BG/jp/WN

3/73-22



S E R V I C E N O T E

7900A-13 SUPERSEDES:

7900A CARTRIDGE DISC DRIVE

All Serial Numbers

STATIC DISCHARGE STRAP

The 7900 Disc Drive has a past history of noisy operation due to bad contact buttons on the spindle. Not only does the noise cause concern among the customers, but also the button causes particles to fall on the servo P.C.A. with a result of intermittent retracts. The problem is caused by a static button which is the wrong composition of metal. The bad button contains 92% silver. It should contain 50% silver and 50% carbon.

However, not all buttons are bad. The disc drives which contain spindles that do not protrude through the spindle pulley have the correct button. In the event the static discharge strap requires changing on a disc drive with a spindle shaft which does not protrude through pulley, order HP P/N 07900-00093.

If however, the disc drive contains a spindle which protrudes through the pulley, the disc drive contains a bad static button. This button causes the excessive noise. To alleviate this situation, replace the present static discharge with a new one (HP P/N 07900-60069). This strap can be installed in place of the old one. However, before replacing the strap, use a piece of fine sandpaper and polish the tip of the spindle. Then install the new strap P/N 07900-60069. Note P/N 07900-60069 can be used ONLY on disc drives which contain a spindle that protrudes through the pulley.

BG/rp/WA

4/73-22



S E R V I C E N O T E

7900A-14 SUPERSEDES:

7900A CARTRIDGE DISC DRIVE

All Serial Numbers

ENCODER LAMP REPLACEMENT

In the event that the lamp in the Encoder Head Assembly (HP P/N 07900-60026) fails, it is not necessary to replace the complete assembly. The encoder lamp can be replaced as an individual assembly.

To obtain the encoder lamp assembly, order HP P/N 07900-60061. This part includes pre-aged lamps and leads.

BG/rp/WN

4/73-22



S E R V I C E N O T E

7900A-15A Supersedes:
7901A-4A

7900A/7901A DISC DRIVE

All Serial Numbers

HEAD ALIGNMENT USING CATSEYE PATTERN

The procedure on the following pages must be followed when using a HP CE Cartridge (P/N 1535-2531) for aligning heads and index transducer.

JG/lm/WN

6/73-22



For more information, call your local HP Sales Office or East (201) 265-5000 • Midwest (312) 677-0400 • South (404) 436-6181 • West (213) 877-1281. Or, write: Hewlett-Packard, 1501 Page Mill Road, Palo Alto, California 94304. In Europe, Post Office Box 85, CH-1217 Meyrin 2, Geneva Switzerland. In Japan, Yokogawa-Hewlett-Packard, 1-59-1, Yoyogi, Shibuya-Ku, Tokyo, 151.

Printed in U.S.A.

A. Head Alignment

To align the disc drive heads using the MDS certification pack, proceed as follows:

1. Install the DSU in the appropriate slot and disconnect channel cable.
2. Turn on the disc power supply and set UPPER DISC PROTECT SWITCH S3 to PROTECT.
3. Install the alignment disc cartridge (part number 1535-2531)
NOTE: For the 7901A, throw S1 on All to TEST (rear) position.
4. Set the LOAD/UNLOAD switch to Load.
5. Set the RESET DRIVE FAULT SWITCH on the disc service unit to ON.
6. Set the disc service unit to allow the disc drive to alternately seek between cylinders 000 and 202. The DELAY switch must be ON. (Refer to Disc Service Unit Operating and Service Manual.)
7. Allow the disc drive to operate in this manner for approximately 25 minutes to stabilize the disc drive temperature. The top cover of the disc drive must be ON during this time.
8. Using the disc service unit, position the carriage to cylinder 100 and select head 0. (100 decimal = 144 octal).
9. Connect the A Channel of the oscilloscope to TP2 on read/write pre-amplifier assembly A13. (A6TP1 for 7901A)
10. Connect the B channel of the oscilloscope to TP4 of the Sector Assembly A8 (A11TP3 for 7901A)
11. Set the oscilloscope for 2 milli-seconds/cm, 0.05V/cm for A channel and ZV/cm for B channel. (chopped).
12. Sync, internal negative on the upper index pulse (A8TP4).
13. Uncalibrate the oscilloscope horizontal until two index pulses can be seen. Adjust the oscilloscope until the two index pulses are on the two outer marks of the oscilloscope scale (SEE Figure 1).
14. Loosen the locking screw holding the head in place.
15. Using the head adjusting tool, position the head until the cross-over point is exactly in the center of the oscilloscope scale (See waveforms in Figure 1).
16. Tighten the locking screw and ensure that the adjustment has not changed.
17. Perform steps 7-15 for Hd 1.

B. Sector Circumferential Adjustment*

To adjust for minimum sector circumferential seek (or skew) proceed as follows:

1. Using the disc service unit, position the carriage at cylinder 95 and select head 0.
2. Connect the A channel of the oscilloscope to TP2 of read/write preamplifier assembly A13. (A6TP1 for 7901A)
3. Connect the B channel of the oscilloscope to TP4 of the sector assembly A8.
4. Sync internal negative on the upper index pulse (A8TP4). (A11TP3 for 7901A)
5. Set the oscilloscope for 5 micro-seconds/cm, A Channel .05V1 cm for A channel, and 2 V/cm for B channel. Make sure scope is set for alternative traces, and horizontal sweep is calibrated.
6. Adjust the sector position variable resistor (A8R²1) for a 20 ± 3 micro-second delay from the index pulse (beginning of sweep) to the start of the first data pulse. (SEE the waveform figure 2)
7. Select Head 1.
8. Observe the waveform and ensure that the first data pulse is $20 \text{ msec} \pm 3 \text{ msec}$.

NOTE

If the above requirements are not met, care should be taken to ensure that the heads are properly seated in the carriage assembly. If heads are seated properly, and alignment cannot be accomplished within specs, replace head that is out of tolerance.

9. Adjust the sector position variable resistor (A8R1) so that the 20 micro-seconds of delay occurs midway between the pulse positions observed in steps "6" and "8", and no greater than 6 microseconds spread between the heads.
10. Remove any alignment tools, inspect heads for foreign matter, and restore the disc drive back to operation.

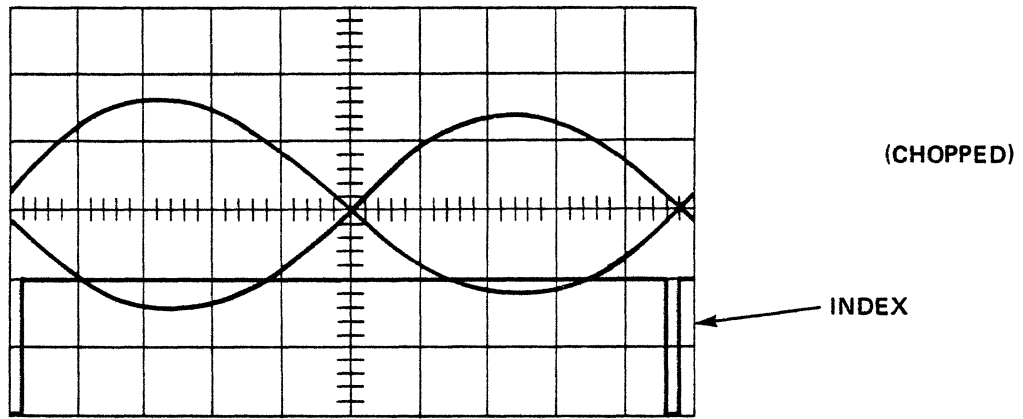

Figure 1. Catseye Pattern

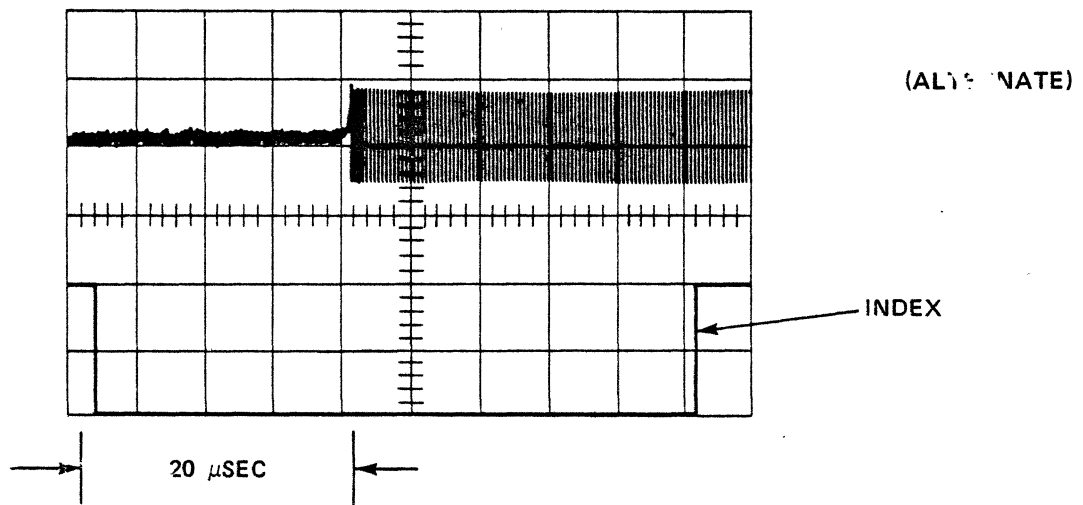

Figure 2. Circumferential Waveform

S E R V I C E N O T E

7901A-1 SUPERSEDES:

HP 7901A DISC DRIVE
RECOMMENDED SPARE PARTS

The attached list provides spare parts provisioning guidelines for HP 7901A cartridge disc drive.

The list is divided into three quantity levels:

- Level I Electrical and Mechanical components most frequency replaced.
- Level II Printed circuit boards and replaceable modules.
- Level III All items included in Level I and II, plus some additional high cost, or low failure rate parts subassemblies. This level is recommended for support of isolated units or depot level maintenance.

The parts are listed in ascending numerical order by HP stock number. Manufacturer code and part number are supplied for purchasing convenience.

BG/ps/WN

2/72-42



HP PART NUMBER	DESCRIPTION	LEVEL 1	LEVEL 2	LEVEL 3	MFR CODE	MFR PART NUMBER
0160-2055	C:FXD CER 0.01 UF +30 -20% 100 VDCW	2		2	56289	C023F101F103ZS22- CDH
0180-0100	C:FXD TA Elect 4.7 UF 10% 35 VDCW	1		1	56289	150D475X9035B2- DYS
0180-0116	C:FXD TA Elect 6.8 UF 10%	1		1	56289	150D685X9035B2- DYS
0180-0197	C:FXD TA Elect 2.2 UF	1		1	56289	150D225X9020A2- DYS
0180-0218	C:FXD TA Elect .15	1		1	56289	150D154X9035A2- DYS
0180-0229	C:FXD TA Elect 33 UF 10% 10 VDCW	1		1	56289	150D336X9015B2- DYS
0180-0291	C:FXD TA Elect 1.0	1		1	56289	150D105X9035A2- DYS
0180-0374	C:FXD TA Elect 10.0	1		1	56289	150D106X9020B2- DYS
0180-0376	C:FXD TA Elect .47	1		1	56289	150D474X9035A2- DYS
0180-1701	C:FXD TA Elect 6.8 MF	1		1	11187	150D685X0006A2- DYS
0180-1746	C:FXD TA Elect 15 UF 10% 20 VDCW	1		1	28480	0180-1746
0180-1835	C:FXD TA Elect 68	1		1	56289	150D686X0015R2- DYS
0180-2207	C:FXD TA Elect 100	1		1	56289	150D107X9010R2- DYS
0698-3132	R:FXD MF 261 OHM 1% 1/8W	1		1	75042	CEA T-0
0698-3136	R:FXD MF 17.8K 1% 1/8W	1		1	75042	CEA T-0
0698-3150	R:FXD MF 2.37K 1% 1/8W	1		1	75042	CEA T-0
0698-3154	R:FXD MF 4.22K 1% 1/8W	1		1	75042	CEA T-0
0698-3155	R:FXD MF 4.64K 1% 1/8W	1		1	75042	CEA T-0
0698-3156	R:FXD MF 14.7K 1% 1/8W	1		1	75042	CEA T-0

HP PART NUMBER	DESCRIPTION	LEVEL 1	LEVEL 2	LEVEL 3	MFR CODE	MFR PART NUMBER
0698-3157	R:FXD MF 19.6K 1% 1/8W	1		1	75042	CEA T-0
0698-3160	R:FXD MF 31.6K 1% 1/8W	1		1	75042	CEA T-0
0698-3161	R:FXD MF 38.3K 1% 1/8W	1		1	75042	CEA T-0
0698-3260	R:FXD MF 464K 1% 1/8W	1		1	75042	CEA T-0
0698-3437	R:FXD MF 133 OHMS 1% 1/8W	1		1	75042	CEA T-0
0698-3439	R:FXD MF 178 OHM 1% 1/8W	1		1	75042	CEA T-0
0698-3440	R:FXD MF 196 OHM 1% 1/8W	1		1	75042	CEA T-0
0698-3441	R:FXD MF 215 OHM 1% 1/8W	1		1	75042	CEA T-0
0698-3450	R:FIX MF 42.2K 1% 1/8W	1		1	75042	CEA T-0
0698-3451	R:FIX MF 133K 1% 1/8W	1		1	75042	CEA T-0
0698-3457	R:FIX MF 316K 1% 1/8W	1		1	75042	CEA T-0
0698-3459	R:FIX MF 383K 1% 1/8W	1		1	75042	CEA T-0
0698-3515	R:FIX MF 5.9K 1% 1/8W	1		1	75042	CEA T-0
0698-3700	R:FIX MF 715 OHM 1% 1/8W	1		1	75042	CEA T-0
0698-4002	R:FIX MF 5.0K 1% 1/8W	1		1	75042	CEA T-0
0698-4007	R:FIX MF 27.8K 1% 1/8W	1		1	75042	CEA T-0
0698-4465	R:FIX MF 931 OHM 1% 1/8W	1		1	75042	CEA T-0
0698-4470	R:FIX MF 6.98K 1% 1/8W	1		1	75042	CEA T-0
0698-4619	R:FIX MF 1.15K 1% 1/8W	1		1	75042	CEA T-0
0698-5088	R:FIX MF 12.0K 1% 1/8W	1		1	75042	CEA T-0
0698-5092	R:FIX MF 160K 1% 1/8W	1		1	75042	CEA T-0
0698-5663	R:FIX MF 330 OHM 1% 1/8W	1		1	75042	CEA T-0
0698-5672	R:FIX MF 2.7K 1% 1/8W	1		1	75042	CEA T-0
0757-0279	R:FIX MF 3.16K 1% 1/8W	1		1	75042	CEA T-0
0757-0280	R:FIX MF 1.0K 1% 1/8W	1		1	75042	CEA T-0
0757-0283	R:FIX MF 2.0K 1% 1/8W	1		1	75042	CEA T-0

HP PART NUMBER	DESCRIPTION	LEVEL 1	LEVEL 2	LEVEL 3	MFR CODE	MFR PART NUMBER
0757-0288	R:FIX MF 9.09K 1% 1/8W	1		1	75042	CEA T-0
0757-0382	R:FIX MF 16.2K 1% 1/8W	1		1	75042	CEA T-0
0757-0398	R:FIX MF 75 OHM 1% 1/8W	1		1	75042	CEA T-0
0757-0401	R:FIX MF 100 OHM 1% 1/8W	1		1	75042	CEA T-0
0757-0402	R:FIX MF 110 OHM 1% 1/8W	1		1	75042	CEA T-0
0757-0403	R:FIX MF 121 OHM 1% 1/8W	1		1	75042	CEA T-0
0757-0416	R:FIX MF 511 OHM 1% 1/8W	1		1	75042	CEA T-0
0757-0417	R:FIX MF 562 OHM 1% 1/8W	1		1	75042	CEA T-0
0757-0420	R:FIX MF 750 OHM 1% 1/8W	1		1	75042	CEA T-0
0757-0428	R:FIX MF 1.62K 1% 1/8W	1		1	75042	CEA T-0
0757-0430	R:FIX MF 2.21K 1% 1/8W	1		1	75042	CEA T-0
0757-0442	R:FIX MF 10.0K 1% 1/8W	1		1	75042	CEA T-0
0757-0443	R:FIX MF 11.0K 1% 1/8W	1		1	75042	CEA T-0
0757-0447	R:FIX MF 16.2K 1% 1/8W	1		1	75042	CEA T-0
0757-0449	R:FIX MF 51.1K 1% 1/8W	1		1	75042	CEA T-0
0757-0462	R:FIX MF 75K 1% 1/8W	1		1	75042	CEA T-0
0757-0465	R:FIX MF 100K 1% 1/8W	1		1	75042	CEA T-0
0811-2490	R:FIX WW 0.1 OHM 3% 5W	1		1	91637	RS5-78
0811-3048	R:FIX 1.5 OHM 5W	1		1	91637	RS5-78
0811-3049	R:FIX 2.75 OHM 10W	1		1	91637	RS10-46
0812-0060	R:FIX 5K 3% 5W	1		1	91637	CW5-2
1000-0276	Plate - Encoder	1		1	28480	1000-0276
1420-0088	Battery - NICAD	0		4	61637	CH500
1810-0020	Res. Network	2		2	56289	200C1098-CRR
1820-0054	IC: TTL QUAD 2 INPT NAND GATE	2		3	01295	SN 7400N

HP PART NUMBER	DESCRIPTION	LEVEL 1	LEVEL 2	LEVEL 3	MFR CODE	MFR PART NUMBER
1820-0068	IC: TTL Triple - 3 - INPUT NAND GATE	2		3	01295	SN7410N
1820-0069	IC: TTL Dual - 4 - INPUT NAND GATE	2		3	01295	SN7420N
1820-0077	IC: TTL Dual D Flip-Flop	2		3	01295	SN7474N
1820-0099	IC: TTL 4-Bit Binary Counter	2		3	27014	SN7493N
1820-0111	IC: TTL BCD to Decimal Decoder	2		3	07263	SL50019
1820-0174	IC: TTL Hex Inverter	2		4	01295	SN 8199
1820-0192	IC: Video and Wide Band Amp	2		3	02735	CA3001
1820-0207	IC: Monostable Multivibrator	2		3	28584	SL12895
1820-0233	IC: TTL Up-down 4-bit counter	2		3	27014	SD7842
1820-0239	IC: TTL Quad 2 INPT Nor Gate	2		4	04713	SC7527PK
1820-0282	IC: TTL Quad 2 INPT Ex or Gate	2		3	01295	SN13603
1820-0305	IC:	2		3	01295	SN7483N
1820-0398	IC: Diff Comparator	2		3	01295	SN72710N
1820-0437	IC: Quad D Flip-Flop	2		3	04713	SC7531PK
1820-0439	IC: Voltage Reg.	2		3	07263	SL21385
1820-0477	IC: Operational Amp	2		3	27014	SL10307
1820-0493	IC: Operational Amp	3		4	27014	SL10084
1820-0511	IC: TTL Quad 2 Input and Gate	2		3	01295	SN20572
1820-0515	IC: TTL Dual Re-trig MV	2		3	07263	SL50099
1820-0535	IC: TTL Dual 2 Input Driver	2		3	01295	SP16150
1820-0537	IC: TTL Dual 4 Input NAND Gate	2		3	01295	SN22158
1820-0577	IC: TTL Hex Inverter	2		3	01295	SN22729
1820-0706	IC: TTL 5 - Bit Comparator	2		3	07263	SN17306

HP PART NUMBER	DESCRIPTION	LEVEL 1	LEVEL 2	LEVEL 3	MFR CODE	MFR PART NUMBER
1820-0722	IC	2		3	01295	SN16725
1820-0723	IC	2		3	01295	SN16724
1826-0064	IC	2		3	07263	SL22456
1853-0010	TSTR SI PNP	2		4	04713	SM4713
1853-0012	TSTR SI PNP	2		3	80131	2N2904A
1853-0036	TSTR SI PNP	2		3	80131	2N3906
1853-0303	TSTR SI PNP	2		3	02735	2N5956
1854-0019	TSTR SI NPN	2		3	07263	S6516
1854-0039	TSTR SI NPN	2		3	80131	2N3053
1854-0045	TSTR SI NPN	2		3	04713	SS2190
1854-0063	TSTR SI NPN	2		3	18722	2N3055
1854-0071	TSTR SI NPN	2		3	01295	SKA1124
1854-0072	TSTR SI NPN	2		3	80131	2N3054
1854-0215	TSTR SI NPN	2		3	80131	2N3904
1854-0519	TSTR SI NPN	2		3	04713	2N3772
1855-0056	TSTR	2		3	07263	2N4342
1855-0078	TSTR FET SI	2		3	01295	SF85572
1884-0012	Rectifier SC	2		3	02735	2N3528
1884-0054	Thyristor: Triac	2		3	86684	40526
1884-0076	Thyristor: Triac	2		3	86684	40430
1884-0088	Thyristor: SCR 200V	2		3	86684	2N3228
1901-0026	Diode: SI 0.75A 200 PIV	2		3	04713	SR1358-8
1901-0040	Diode: SI 30 MP 30 WV	4		7	07263	EDG1088
1901-0418	Diode: SI 3 AMP 400 PIV	2		3	04713	SR1846-12
1901-0450	Diode: SI	2		3	09214	S156/DHD125
1901-0460	Diode: SI 3 Layer	2		3	03508	STB523

HP PART NUMBER	DESCRIPTION	LEVEL 1	LEVEL 2	LEVEL 3	MFR CODE	MFR PART NUMBER
1902-0025	Diode: Zener 10.0V	2		3	04713	SZ10939-182
1902-0041	Diode: Zener 5.11V	2		2	04713	SZ10939-98
1902-0048	Diode: Zener 6.81V	2		2	04713	SZ10939-134
1902-0049	Diode: Zener 6.2V	2		2	04713	SZ10939-122
1902-3059	Diode: Zener 3.83V	2		2	04713	SZ10939-62
1902-3082	Diode: Zener 4.64V	2		2	04713	SZ10939-86
1902-3149	Diode: Zener 9.09V	2		2	04713	SZ10939-170
1902-3193	Diode: Zener 13.3V	2		2	04713	SZ10939-218
1902-3203	Diode: Zener 14.7V	2		2	04713	SZ10939-230
1906-0032	Rectifier: Power	2		2	04713	MDA 980-3
2100-1757	R. Var 500 OHM	1		2	75042	CT 106-4
2100-2489	R. Var 5K OHM	1		2	73138	62-226-1
2100-2514	R. Var 20K OHM	1		2	73138	62-228-1
2110-0016	Fuse - 6 AMP	5		5	75915	313-600S
2110-0030	Fuse - 5 AMP	5		5	75915	313005
2110-0036	Fuse - 8 AMP	5		5	75915	
2110-0342	Fuse - 8 AMP	5		5	75915	314-008
2110-0365	Fuse - 4 AMP	5		5	71400	MDA - 4 AMP
2140-0343	Lamp, Incandescent 14V 0.8A	3		5	98978	330
3101-0070	Switch, Slide	1		1	79727	GF126-000
3101-1213	Switch, DPDT	1		1	09298	T8001
3101-1258	Switch, SPDT	1		1		
3101-1395	Switch, Pushbutton	1		1	87034	53-67280-121/A1H
3101-1607	Switch, Sensitive	1		1	01963	E23-00K
3101-1608	Switch, Sensitive	1		1	01963	E21-36HX

HP PART NUMBER	DESCRIPTION	LEVEL 1	LEVEL 2	LEVEL 3	MFR CODE	MFR PART NUMBER
3101-1617	Switch, Sensitive	1		1	01963	E63-24K
3140-0761	Motor, Drive			1	03596	19HG
3150-0231	Filter, Absolute	1		1		
4208-0039	Filter, Front	1		1		
5060-0049	Preamp, Extender	1		1	28480	5060-0049
9100-1623	Inductor, 27 UH 5%	1		1	28480	9100-1623
9100-1627	Inductor 39 UH 5%	1		1	82142	15-1315-2J
07900-60001	Head-up			1	28480	07900-60001
07900-60004	Head Down			1	28480	07900-60004
07901-60002	Drive Control PC Assy		1	1	28480	07901-60002
07901-60003	Preamp PC Assy		1	1	28480	07901-60003
07901-60004	R/W Control PC Assy		1	1	28480	07901-60004
07901-60005	Sector/Cyl PC Assy		1	1	28480	07901-60005
07901-60006	Encoder PC Assy		1	1	28480	07901-60006
07901-60007	I/O Multiplex PC Assy		1	1	28480	07901-60007
07901-60008	Motor Control PC Assy		1	1	28480	07901-60008
07901-60009	Servo Amp/Reg PC Assy		1	1	28480	07901-60009
07901-60013	Termination PC Assy		1	1	28480	07901-60013
07901-60014	Indicator PC Assy		1	1	28480	07901-60014
07901-60022	Coil Lead Assy			1	28480	07901-60022
07901-60028	Unit Select Switch Assy			1	28480	07901-60028

S E R V I C E N O T E

7901-2 SUPERSEDES:

HP 7901A DISC DRIVE

Tools, Test Equipment and Maintenance Supplies

Listed below are the tools, test equipment and maintenance supplies required for maintaining, aligning and repairing the HP 7901A Disc Drive.

Oscilloscope Set as follows or equivalent:

HP 180A, Oscilloscope	1 each
HP 1801A, Dual Chan. Vertical Amp	1 each
HP 1821A, Time Base	1 each
HP 10006A, Probe, 10:1	3 each

Digital Voltmeter Set as follows or equivalent:

HP 427A, Multi-Function	1 each
	1 each

Disc Service Unit:

HP 13219A Service Unit	1 each
Head Cleaning Tool, 07900-00091	1 each
Extender Board, 07901-60012	1 each
Preamp Extender Board, 5060-0049	1 each
Alignment Cartridge, 1535-0066	1 each
Mylar Feeler Gauge 0.005", 1535-0648	1 each
Filtered Alcohol (6 oz), 1535-1432	1 each
Lint Free Tissue (Kimwipe), 9300-0001	1 box

Standard Tools:

Posi Drive Screwdriver	(Stanley 2951)
Posi Drive Screwdriver	(Stanley 2952)
Long Nose Pliers	(Xcclite 71CG)
Wire Cutters	(Xcclite 74CG)

BG/ps/WN

(over)

2/72-41



Standard Tools (continued)

Screwdriver 4" x 1/4"	(Xcclite R-144)
Screwdriver 4" x 1/8"	(Xcclite R-184)
Wire Stripper	(K-Miller 101-S)
6" Steel Rule	(General 616)
Soldering Iron	(Ungar 6010)
Inspection Mirror	(G.C. Elect. 5090P)
IC Pin Clip	(A-P Inc)
Socket Keys	(Xcclite 99 PS-40)

S E R V I C E N O T E

HP 7901A DISC DRIVE

SUPERSEDES:

INSTALLATION GUIDE

7901-3

This service note is intended to facilitate installation of the 7901A Disc Drive and associate equipment at end user sites using HP 2100 Series Computer. Documents referenced to in this note have been provided with disc system.

This device must be installed by HP trained personnel who are familiar with installation and service techniques. If system is damaged as a result of installation by unauthorized personnel, the warranty will be void.

A complete 7901A Disc System consists of a 13210 Interface Kit and one to four 7901 Disc Drives. This service note is intended to assist in installing such a system in a HP 2940 A Cabinet.

The following materials will be received when a complete system is installed:

13210A Interface Kit

13210-60000	Disc 2 Interface Board
13210-60004	Disc 1 Interface Board
13210-60003	Interface Cable
13210-90003	Operating and Service Manual
13210-90004	Diagnostic Manual
13041-60001	Diagnostic Tape

7901A Disc Unit

9164-0045	24 Sector Cartridge
07901-90003	Disc Operating and Service Manual
07901-60013	Termination P.C. Assy
07900-60034	Multi-unit Cable (required if two or more drive are installed)

Remove all packing materials, straps, etc. Inspect all equipment thoroughly for damage which may have occurred during shipment. Report any damage to the carrier and nearest HP sales office immediately.

BG/lm/wn

(CONTINUED)

3/72-42

HEWLETT  PACKARD

INSTALLATION GUIDE

-CAUTION-

Dangerous voltages are present in the system which requires application of standard safety precautions.

Special tools and equipment are required to install the 7901A Disc System. These tools are described in Service Note 7901A-2.

Refer to Section 11 of the 13211A Rack Slide Mounting Kit Installation Manual for additional information.

1. Install the mounting kit in the 2940A Cabinet.
2. Mount the slide on the 7901A Drive
3. Extend the slide racks and install the 7901A Drive in the cabinet.

Refer to Section 2 of the 7901A Operating and Service Manual to insure that TBI is wired for the proper primary power source.

-NOTE-

If this unit is to be connected to any power source other than 110-120 VAC, 60 Hz, a power cable plug must be locally purchased to meet requirements.

Check to insure that no electrical continuity exists between the 7901A and 2940A Cabinet.

Refer to Section 5 of the 7901A Operating and Service Manual.

1. Extend the drive units slides out and remove the top cover. Remove the carriage shipping detent to allow carriage motion. The carriage shipping detent should be saved for future use in the event the equipment is relocated.
2. To insure proper cartridge seating, clean any foreign material from the spindle magnet.
3. Check the drive alignment as specified in Section 5 of the Operating and Service Manual. Insure that the following adjustments are within the required specifications:

Encoder Clearance	Para. 5-42
Encoder Parallelism	Para. 5-44
Encoder Alignment	Para. 5-46
Servo Adjustment	Para. 5-48

4. To insure cartridge interchangeability, check the following adjustments:

Head Alignment	Para. 5-50
Sector Circumferential	Para. 5-52

(CONTINUED)

INSTALLATION GUIDE

Refer to Section II of the 13210A Operating and Service Manual.

1. Install the disc interface P.C. Boards in the desired I/O select code slots in the computer. The Disc I interface board will be installed in the high priority (lower number) I/O slot.

-NOTE-

If the interface kit is being installed in a 2116A, Resistor R-22 on the Disc I board must be desoldered and moved to the empty connection pad (+5V) between R22 and C-16. Refer to Figure 4-1 (parts location) and the schematic diagram (grid location D-8) in the 13210A Operating & Service Manual.

2. Connect the interface cable between the interface boards and the A13 P.C.A. receptacle on the back of the drive.
3. Install the termination P.C. Board in the A14 receptacle on the drive.
4. If more than one drive is connected to the interface, a multi-unit cable must be used to daisy chain the drives together. This cable should be connected between the A14 (using an I/O extender in place of the terminator board) and A14 of the adjacent drive. The terminator P.C.A. must be installed in the last unit on line.
5. Insure that the correct drive address is selected (Drive address switch under front door).

-NOTE-

Insure that no two drives have the same select address.

Refer to the 7900/13210 Diagnostic Manual for operating instructions and failure analysis.

1. Install a spare cartridge and load the drive being installed.
2. Use the diagnostic program to initialize the disc. This may be accomplished as follows:

Set the DATA PROTECT switch to off. Set the PROTECT/OVERRIDE switch (located behind course filter screen) to OVERRIDE. Use the operator design section (S-7) of the diagnostic and execute the following instructions:

```
SD, X
LB, AA
IS
ID
RT, AA 202 (Loop 202 Times)
HT, 777 (HIT display 7778)
EN
```

3. Verify proper operation of the drive by running the complete diagnostic program.

S E R V I C E N O T E

HP 13210 Disc Interface #2

13210A-1A SUPERSEDES:

HP P/N 13210-60000 and 13210-60005

Serial Number Prefix 1138A and Below

Product Improvement Change

A recent engineering change was made on the disc Interface "2" PCA to improve data reliability. This change increases the width of the data window by improving the rise time of the data window pulse. This enables the Interface to reliably detect the "SYNC 1" word and in turn improve VCO lockup.

Parts Required

<u>Qty</u>	<u>Description</u>	<u>HP Part No.</u>	<u>Ref. Des.</u>
2	Res. Fix. 5.6K 1/4 5%	0683-5625	F11 & 13
1	Label	7124-2099	

IMPLEMENTATION

1. Remove Disc Interface "2" PCA. from Computer.
2. Refer to attached figure. Replace R11 and R13 with 5.6K Resistors.

NOTE: Use a low wattage soldering Iron to avoid damage to the multi layer board.
3. Change the serial number label to read 1210-A-xxxxx.
4. Place the Interface Card on a service extender and connect Interface cables.
5. Turn on Power to the Disc Drive and Computer.
6.
 - a. Allow at least 5 minutes warm-up time, connect TP2 (U111A, pin 2) to ground and connect digital frequency counter to TPI (Ug1B, pin 4).
 - b. Frequency counter should read between 2.495 and 2.505 MHz.
 - c. If required, adjust C18 to obtain a counter reading between 2.495 and 2.505 MHz.
7. Remove Extender and run the diagnostic.
8. Return the system to Normal operation.
9. Make the above changes in the 13210A Operating and Service Manual.

BG/lm/WN



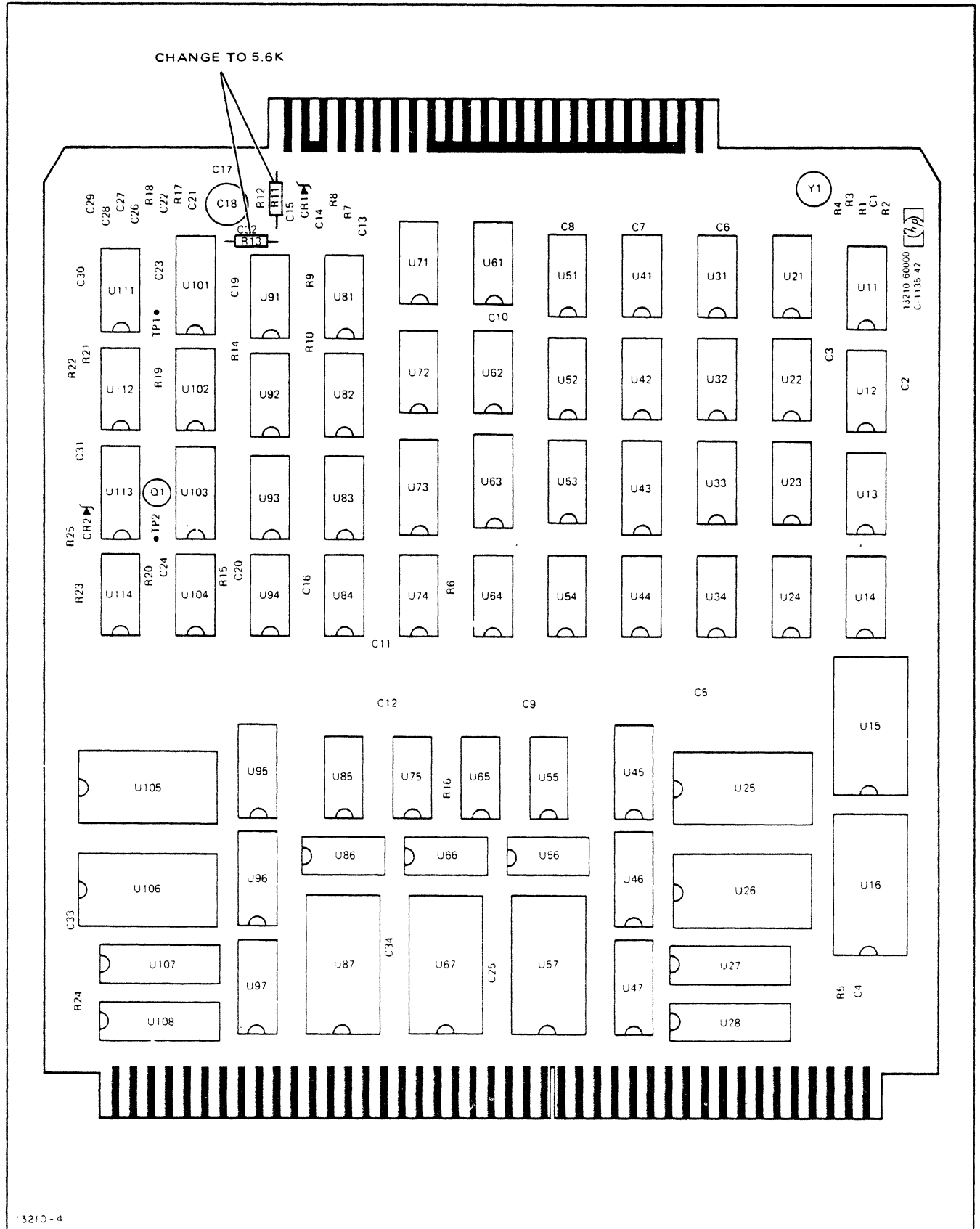

Figure 4-3. Disc Interface 2 PCA Parts Location Diagram

S E R V I C E N O T E

13210A-2 SUPERSEDES:

13210A DISC INTERFACE

All Series

INTERMITTENT RANDOM DATA ERRORS

Some IC'S in the 13210A require a minimum of 4.5 volts for VCC. If the supply does not meet this minimum requirement, random data errors may result.

To insure this problem does not occur, check (and adjust if necessary) the computer supply voltages after all I/O interface boards are installed.

BG/lm/WN

5/72-22

HEWLETT  PACKARD

For more information, call your local HP Sales Office or East (201) 265-5000 • Midwest (312) 677-0400 • South (404) 436-6181 West (213) 877-1282. Or, write: Hewlett-Packard, 1501 Page Mill Road, Palo Alto, California 94304. In Europe, 1217 Meyrin-Geneva

S E R V I C E N O T E

13210-3 SUPERSEDES:

HP 13210A DISC INTERFACE
 Daisy Chaining 4 Disc Drives
 13210-60004 Disc Interface 1 P. C. A.
 Serial No. Prefix 1211A and Below

The increased capacitance resulting from adding a fourth disc drive on the 13210A daisy chain may cause write errors. The problem is caused by delaying Sector Compare in the controller and failing to set the write latch. To alleviate this problem, change C14 on the disc Interface 1 PCA.

PARTS REQUIRED

<u>QTY</u>	<u>DESCRIPTION</u>	<u>HP P/N</u>	<u>REF. DESIGN</u>
1	Cap. Fix 5000 PF	0160-2145	C14

IMPLEMENTATION

Remove Disc 1 from CPU.

Replace C14 with 5000 pf Capacitor. Refer to 13210 Operating and Service Manual for Part Location.

Change the Serial No. Prefix of the PCA to 1232A-xxxxx.

Change the Operating and Service Manual Parts List to reflect the above change.

NOTE: This change is mandatory on all 4 disc drive systems and should be done on the remainder of the 13210's at next PM.

BG/lm/WA

22-9/72

HEWLETT  PACKARD

S E R V I C E N O T E

13219A-1A SUPERSEDES:

HP 13219A DISC SERVICE UNIT

Serial No. 1202A & Below

13219-60001 P.C.A.

INTERMITTENT SEEK WITH THE DELAY SWITCH IN OFF POSITION

In the event that the Disc Service Unit (DSU) intermittently seeks with the switch off a resistor and capacitor can be changed to alleviate this problem.

PARTS REQUIRED

<u>QTY</u>	<u>DESCRIPTION</u>	<u>HP P/N</u>	<u>REF DESIGNATION</u>
1	Cap. Fxd 470 PF	0160-3533	C2
1	Res. Fxd 38.3K	0698-3161	R5

IMPLEMENTATION

1. Gain access to 13219-60001 PCA. Refer to the DSU Operating and Service Manual to gain access to PCA.
2. Locate C2 and R5 and replace with new value.
3. Change the Serial No. Prefix to 1219A-xxxxx.
4. Reassemble and check DSU operation.

BG/ng/WN

22-9/72



S E R V I C E N O T E

7900A-17 Supersedes:

7900A CARTRIDGE DISC

All Serial Numbers

OPERATING IN A MULTI-DRIVE ENVIRONMENT

When operating the 7900A Drive in a Multi-Drive environment do not turn the power off on any one of the drives. If power is removed from any drive in the string a drive fault will result. The drive fault is caused by signal lines in the drive not being pulled up with the internal 5 volt power supply.

BG/slj/WN

7/73-22



For more information, call your local HP Sales Office or East (201) 265-5000 • Midwest (312) 677-0400 • South (404) 436-6181 • West (213) 877-1281. Or, write: Hewlett-Packard, 1501 Page Mill Road, Palo Alto, California 94304. In Europe, Post Office Box 85, CH-1217 Meyrin 2, Geneva, Switzerland. In Japan, Yokogawa-Hewlett-Packard, 1-59-1, Yoyogi, Shibuya-Ku, Tokyo, 151.

Printed in U.S.A.

S E R V I C E N O T E

7901A-6 Supersedes:

7901A DISC DRIVES

Serial No. 1321A-00235 and Below

POWER SUPPLY FUSE LABEL CHANGE

On the early produced 7901A Disc Drives, the silk screened identification of fuses F1 and F3 were reversed in regards to fuse values. The fuses are located behind the front air filter.

To correct this problem, two stickers have been developed to label the fuses correctly. The F1 sticker is HP P/N 7120-3834 and reads:

F1
8A
250
VAC

Before, the fuse was labeled 6.25A.

The F3 sticker is HP P/N 7120-3833 and reads:

F3
6.25A
250
VAC

Before, the fuse was labeled 8A.

On figure 5-43 of the 7901A Operation and Service Manual change the value of F3 from 6A to 6.25A.

JG/lm/WA

7/73-22

HEWLETT  PACKARD

For more information, call your local HP Sales Office or East (201) 265-5000 • Midwest (312) 677-0400 • South (404) 436-6181 • West (213) 877-1281. Or, write: Hewlett-Packard, 1501 Page Mill Road, Palo Alto, California 94304. In Europe, Post Office Box 85, CH-1217 Meyrin 2, Geneva, Switzerland. In Japan, Yokogawa-Hewlett-Packard, 1-59-1, Yoyogi, Shibuya-Ku, Tokyo, 151.

Printed in U.S.A.

