

# **DPS8 46/70 LO PROFILE REFERENCE MANUAL**



This document and the information contained herein are confidential to and the property of Honeywell Information Systems Inc. and are made available only to Honeywell employees for the sole purpose of maintaining Honeywell's products. This document, any copy thereof and the information contained herein shall be maintained in strictest confidence; shall not be copied in whole or in part except as authorized by the employee's manager; and shall not be disclosed or distributed (a) to persons who are not Honeywell employees, or (b) to Honeywell employees for whom such information is not necessary in connection with their assigned responsibilities. Upon request, or when the employee in possession of this document no longer has need for the document for the authorized Honeywell purpose, this document and any copies thereof shall be returned to the employee's manager. There shall be no exceptions to the terms and conditions set forth herein except as authorized in writing by the responsible Honeywell Vice President.

**G.796**

**This document and the information contained herein are confidential to and the property of Honeywell Information Systems Inc. and are made available only to Honeywell employees for the sole purpose of maintaining Honeywell's products. This document, any copy thereof and the information contained herein shall be maintained in strictest confidence; shall not be copied in whole or in part except as authorized by the employee's manager; and shall not be disclosed or distributed (a) to persons who are not Honeywell employees, or (b) to Honeywell employees for whom such information is not necessary in connection with their assigned responsibilities. Upon request, or when the employee in possession of this document no longer has need for the document for the authorized Honeywell purpose, this document and any copies thereof shall be returned to the employee's manager. There shall be no exceptions to the terms and conditions set forth herein except as authorized in writing by the responsible Honeywell Vice President.**

**M.S. J-10  
HED AZ07**

February, 1984

**HONEYWELL CONFIDENTIAL AND PROPRIETARY**

REFERENCE MANUAL  
DPS8 46/70 LO PROFILE  
TABLE OF CONTENTS

	<u>Figure</u>
LESSON 1: GEOGRAPHY AND CONFIGURATION	
DPS-8 Lo Profile Single System Module . . . . .	1-1
System Components . . . . .	1-2
CPU Cabinet Panels . . . . .	1-3
MMU Cabinet Panels . . . . .	1-4
IOM Cabinet Panels . . . . .	1-5
Cabinet Zones and Locations . . . . .	1-6
Components Common to All Cabinets . . . . .	1-7
Memory Port Mapping . . . . .	1-8
Site "C" Layout . . . . .	1-9
LESSON 2: DYNAMIC MAINTENANCE PANEL SELF-TESTS	
(All References for Lesson 2 are in the Dittybook Supplement, Pages 9-1 thru 9-6.)	
LESSON 3: AUTO TESTS	
Field Auto and CPU Subset . . . . .	3-1
Auto Features . . . . .	3-2
Auto Test Initiation . . . . .	3-3
Sample Test Listing . . . . .	3-4
Test Sequence Execution (Shs. 1, 2) . . . . .	3-5
Test Sequence Options . . . . .	3-6
LESSON 4: LO PROFILE POWER	
Typical Cabinet Front View . . . . .	4-1
Power On Sequence (Shs. 1 thru 3) . . . . .	4-2
Power System Overview . . . . .	4-3
IOM Power Modules . . . . .	4-4
CPU Power Modules . . . . .	4-5
MMU Power Modules . . . . .	4-6
High Voltage Buss . . . . .	4-7
Cabinet Air Flow . . . . .	4-8
Typical +5V Regulator . . . . .	4-9
Power Control Module . . . . .	4-10
Examples of Overtemperature Alarm Indications (Sheet 1) . . . . .	4-11
Examples of Overtemperature Shutdown Indicators (Sheet 2) . . . . .	4-11
Power Faults/DC Confidence . . . . .	4-12
Maintenance Aids (Sheets 1 thru 6) . . . . .	4-13

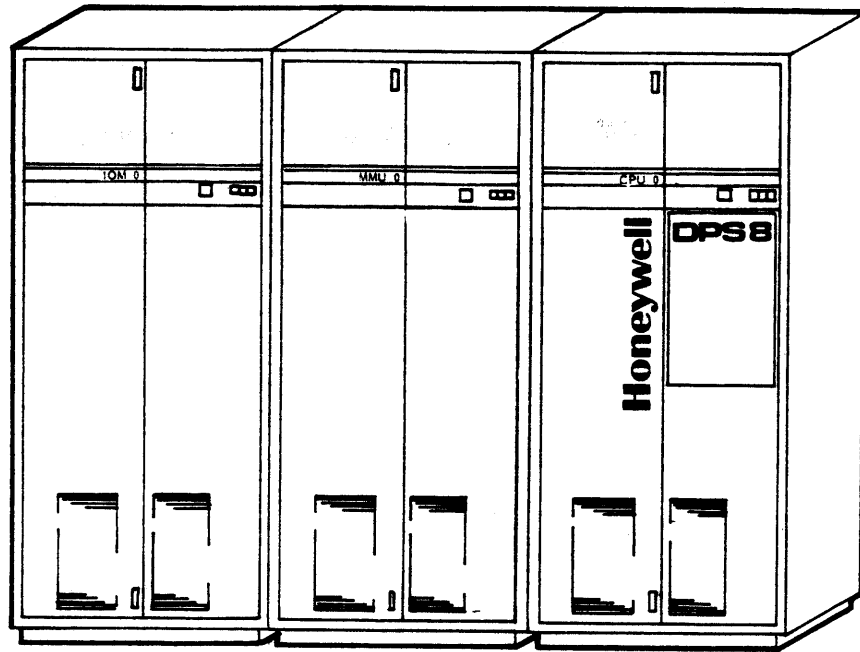

**HONEYWELL CONFIDENTIAL AND PROPRIETARY**  
DPS-8 Low Profile Single System Module  
Figure 1-1

8-52/62

2 sys. console

4 meg words

8-70

4 CPU, IOU, MMU

4 meg words

⊗ FNP

4 system console

16 megabytes

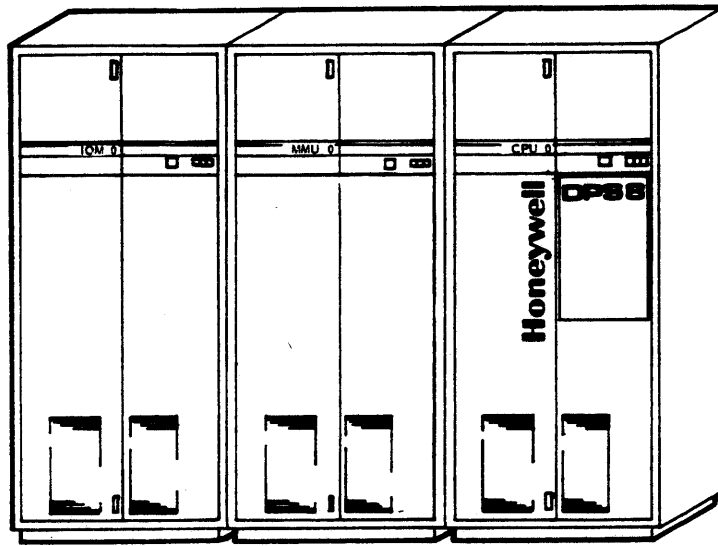

CENTRAL SYSTEM

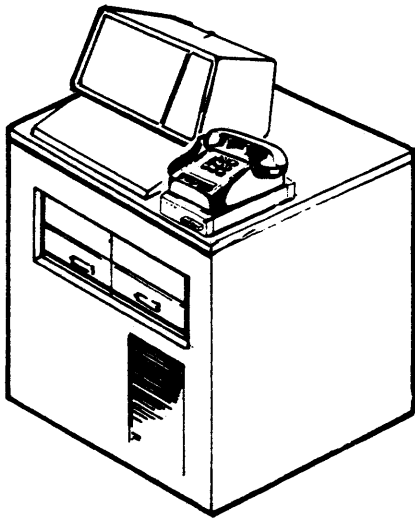

DPU SUBSYSTEM

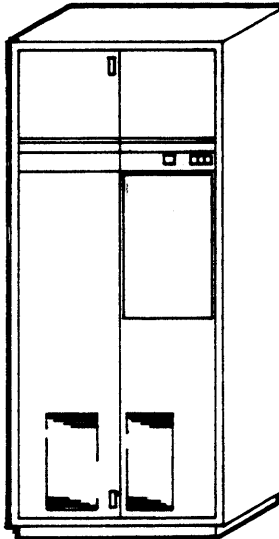

MICROPROGRAMMED PERIPHERAL CONTROLLER



SYSTEM CONSOLE

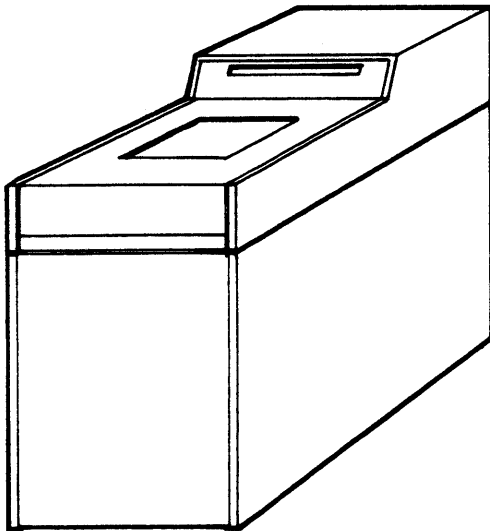

DISK DRIVE

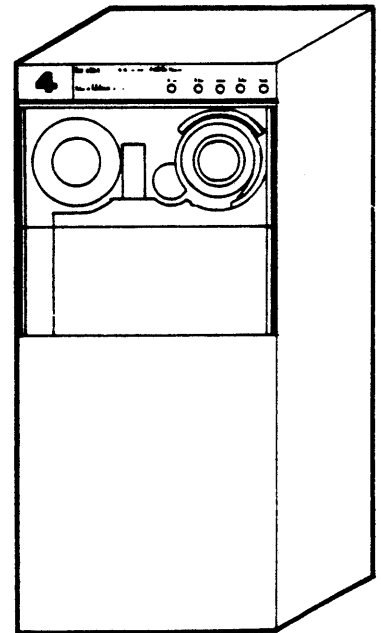

TAPE DRIVE

HONEYWELL CONFIDENTIAL AND PROPRIETARY

System Components  
Figure 1-2

CPU CABINET PANELS

In the single system module, the CPU cabinet is to the extreme right as illustrated here. The operator's Control Panel is mounted on the front of the right door.

Also illustrated on this page are the Zone location designators, Maintenance Panel connector, and CPU Configuration Panel. The CPU Configuration Panel is located on the inside of the left door. Refer to the Test and Repair Manual, 58009927, for more information.

The CPU cabinet Zone V contains the cabinet power panels.

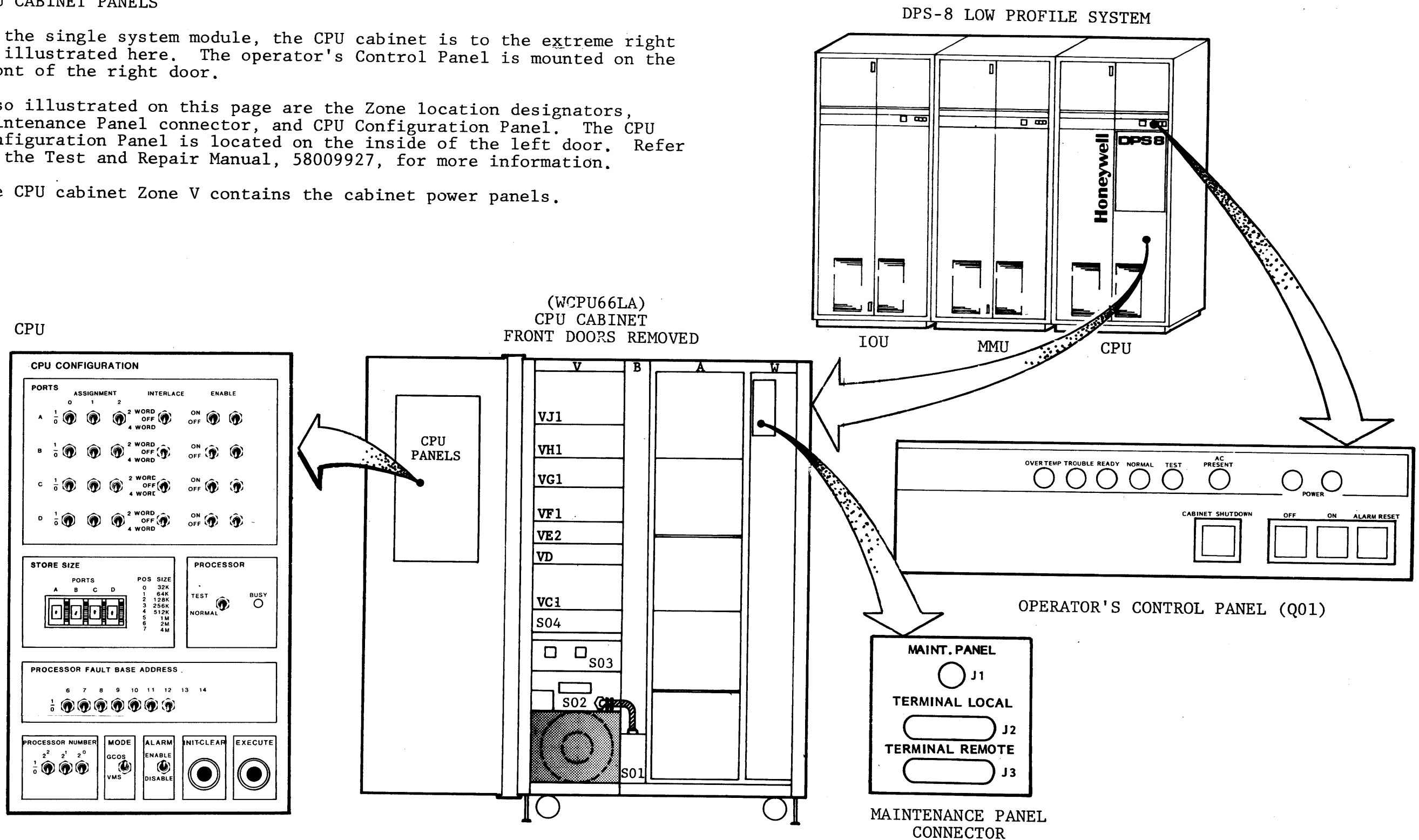

HONEYWELL CONFIDENTIAL AND PROPRIETARY

CPU Cabinet Panels

Figure 1-3

MMU CABINET PANELS

In the single system module configuration, the MMU cabinet is the center cabinet. The Operator's Panel, Maintenance Panel connector plate, Syndrome Panel, SCU Configuration Panel, and SCU Maintenance Panel are illustrated on this page. The syndrome and SCU panels are located on the inside of the left door. Refer to the Test and Repair Manual, 58009927, for more information.

Cabinet Zone V contains the cabinet power panels.

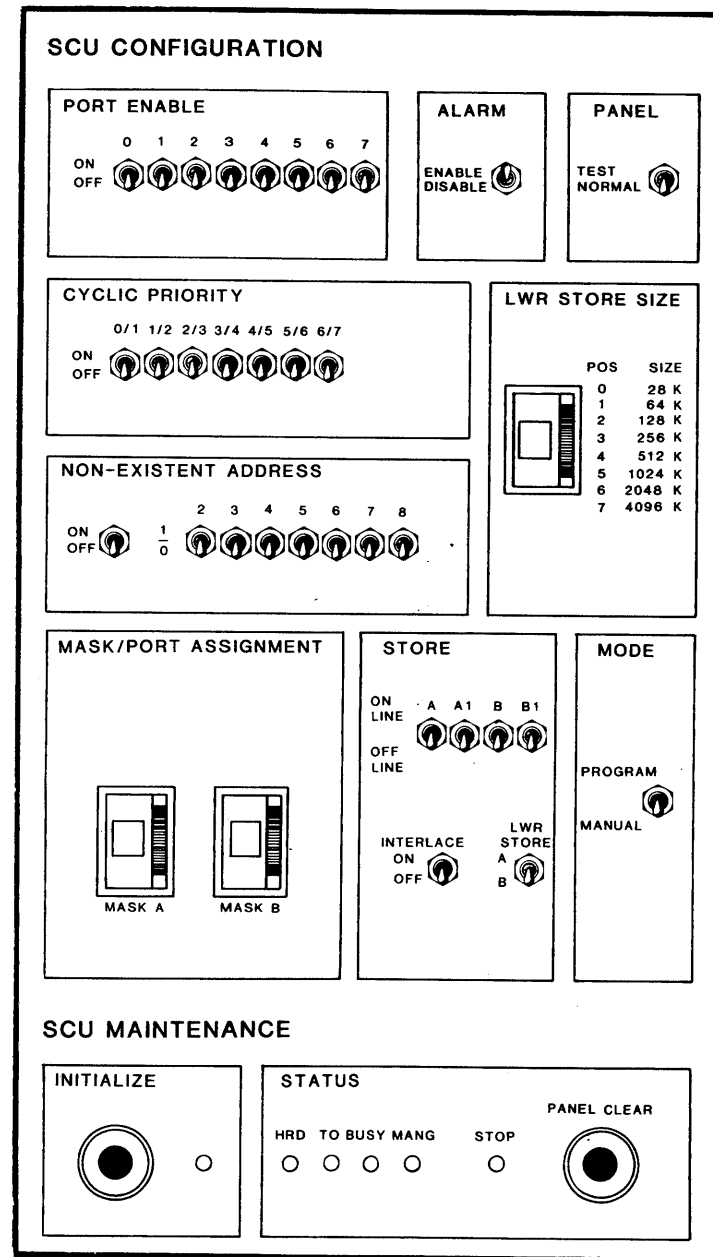
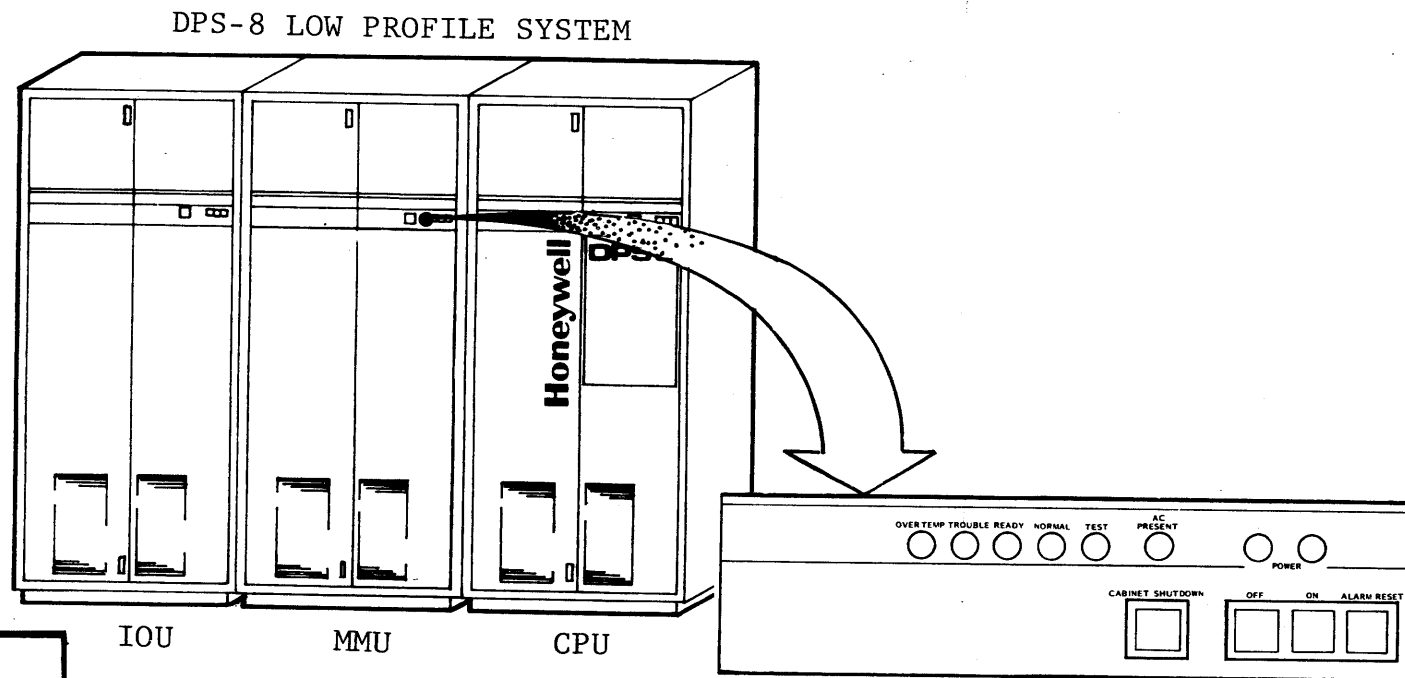

CONFIGURATION PANEL

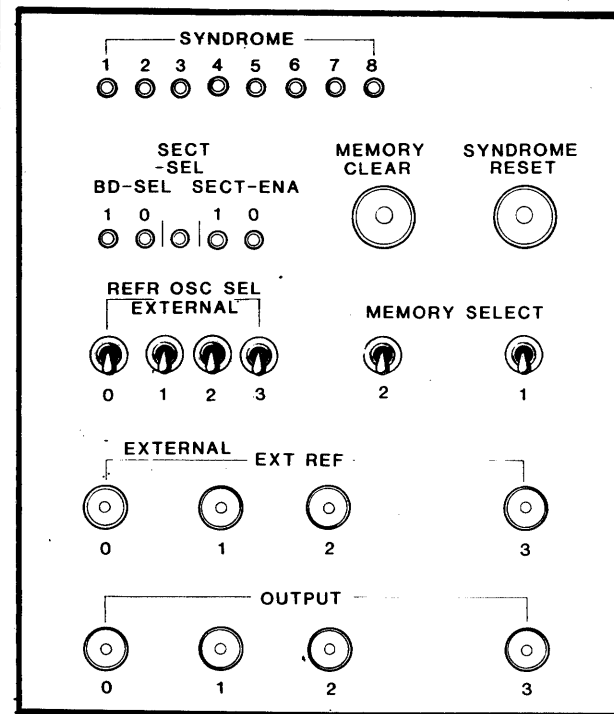

SYNDROME PANEL

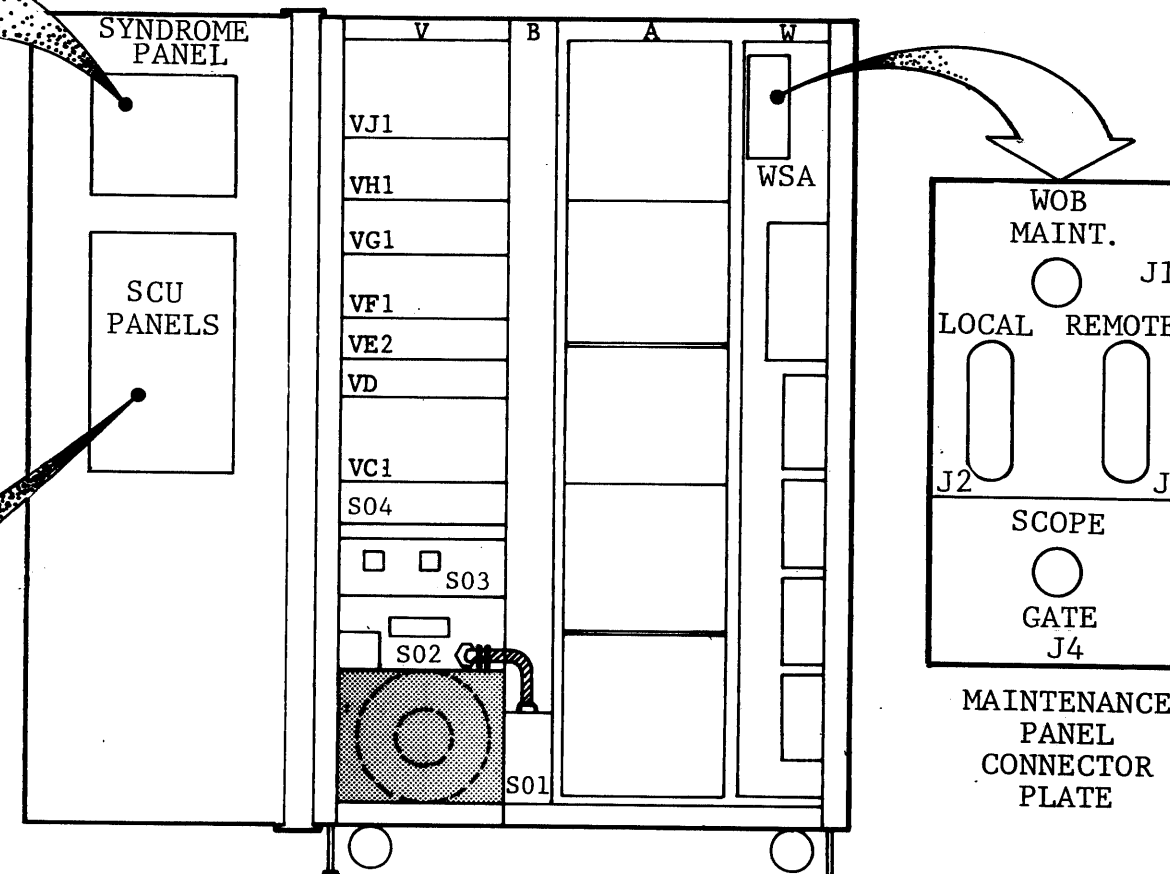

MMU CABINET WITH LEFT DOOR OPEN AND RIGHT DOOR REMOVED

MMU Cabinet Panels

HONEYWELL CONFIDENTIAL AND PROPRIETARY

Figure 1-4

IOM CABINET PANELS

The IOM Cabinet Panel locations illustrated here are those in the single system module. Also illustrated are the cabinet zone locations designators, Operator's Control Panel, Maintenance Panel Connector, and IOM Configuration and Bootload Panels located on the inside of the left door. Refer to the Test and Repair Manual, 58009927, for more information.

IOM Cabinet Zone V contains the power panels.

CONFIGURATION PANEL

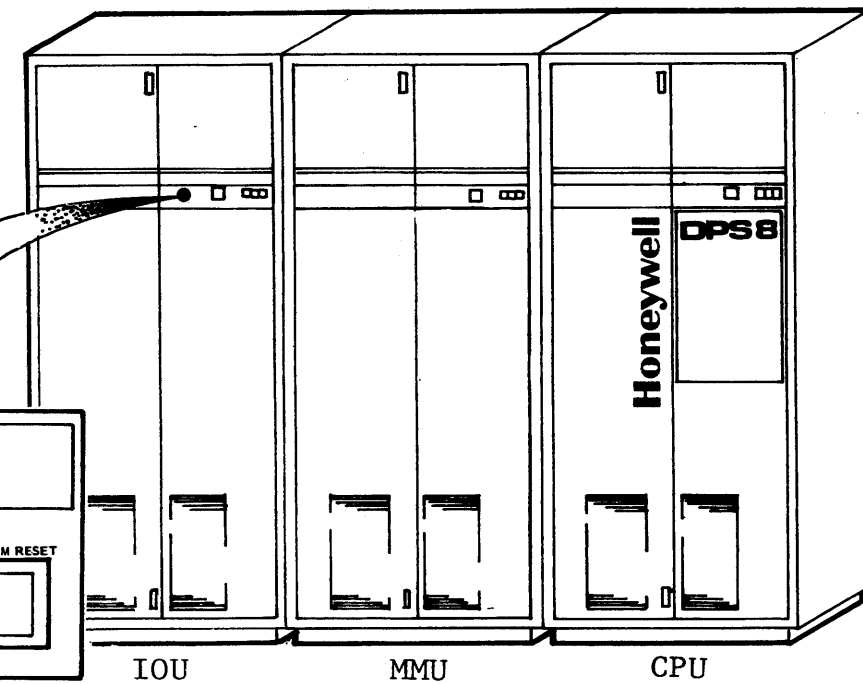
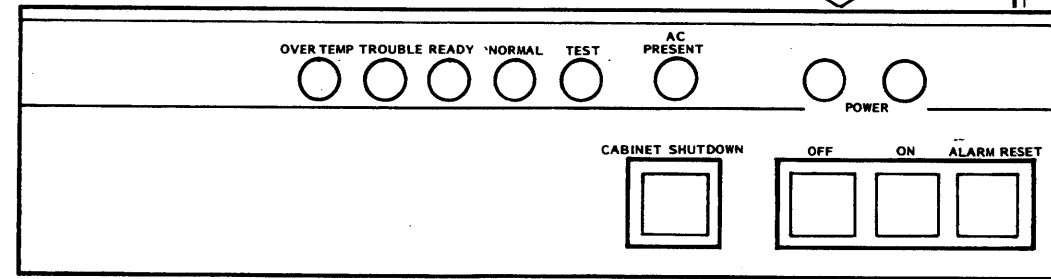
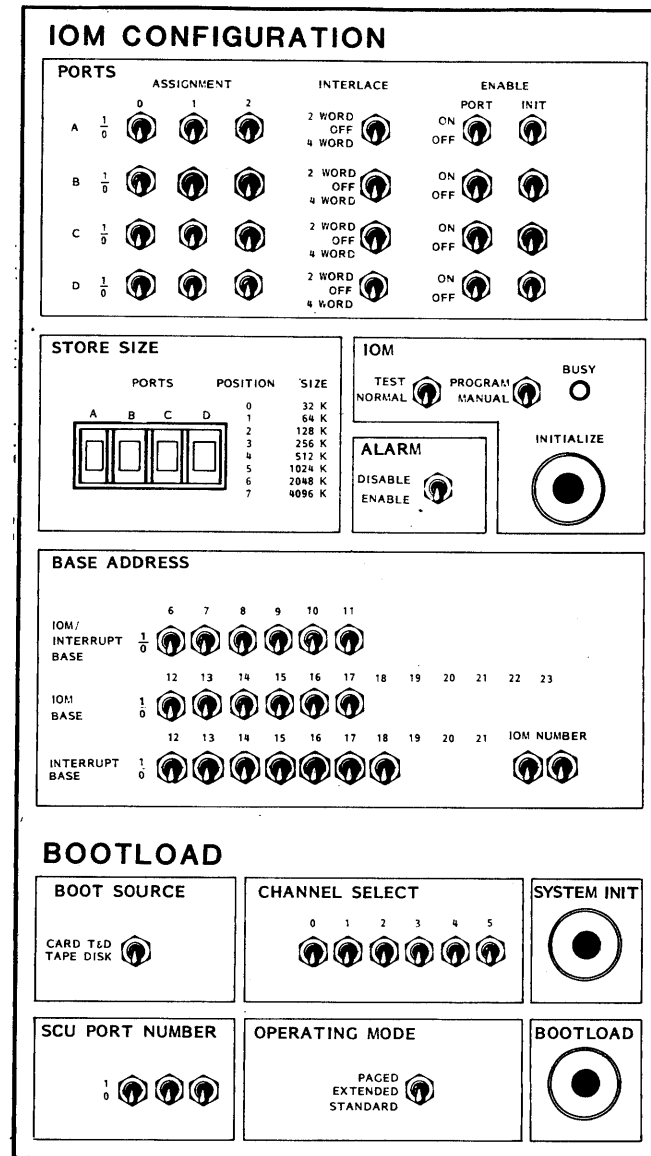

IOM CABINET  
LEFT DOOR OPEN, RIGHT DOOR REMOVED

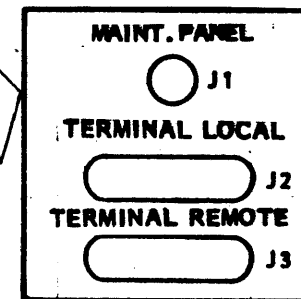
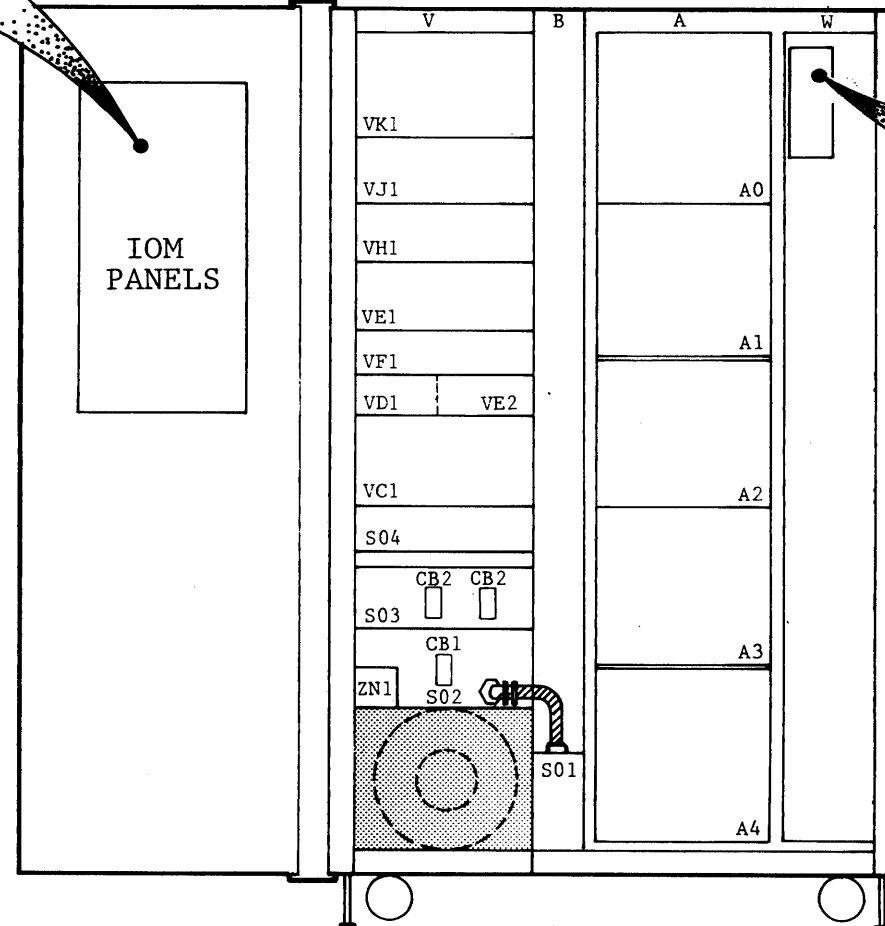

MAINTENANCE PANEL  
CONNECTOR

IOU Cabinet Panels

Figure 1-5

HONEYWELL CONFIDENTIAL AND PROPRIETARY



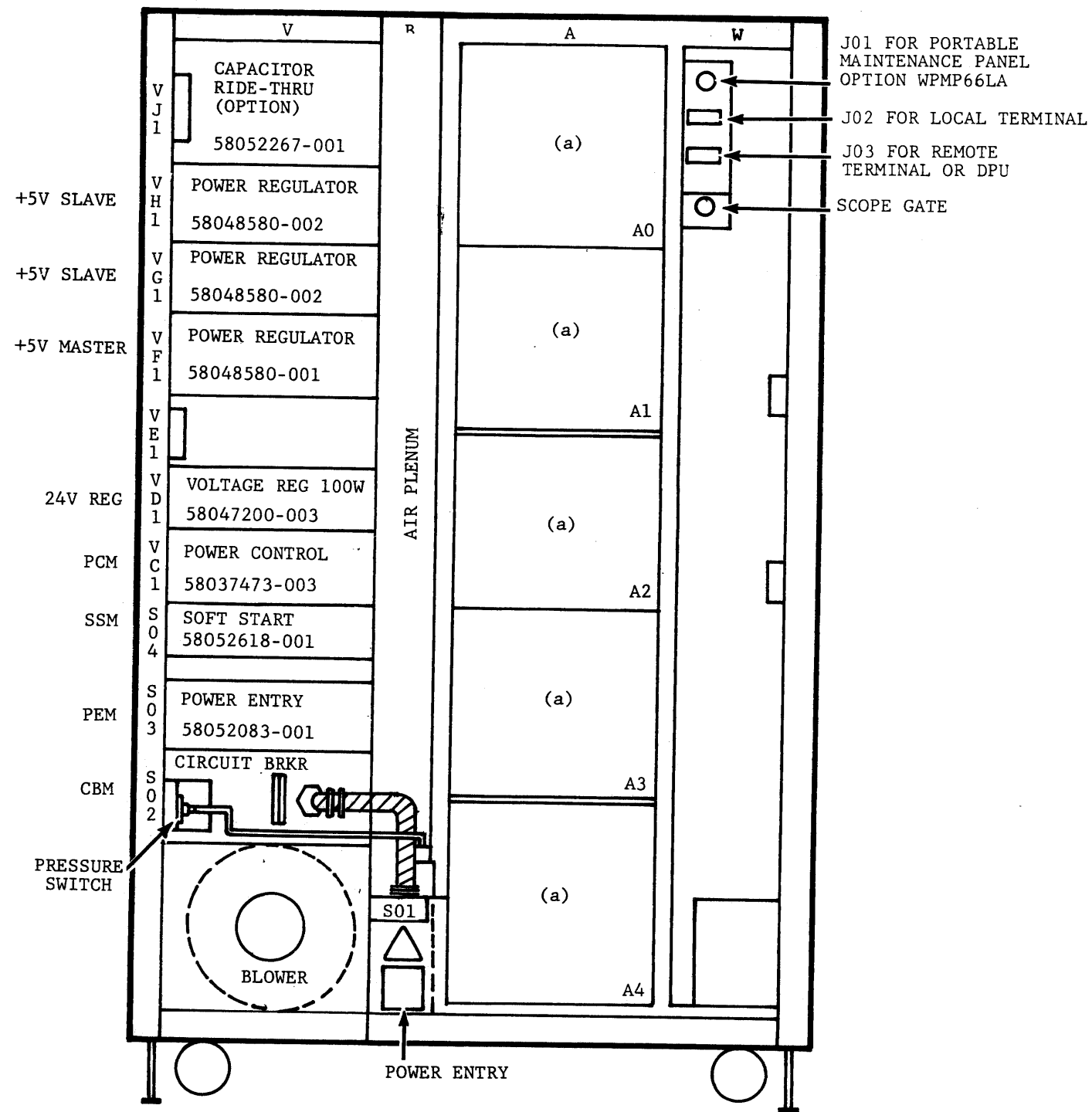

FRONT VIEW  
POWER AND LOGIC  
MODULE DOORS REMOVED

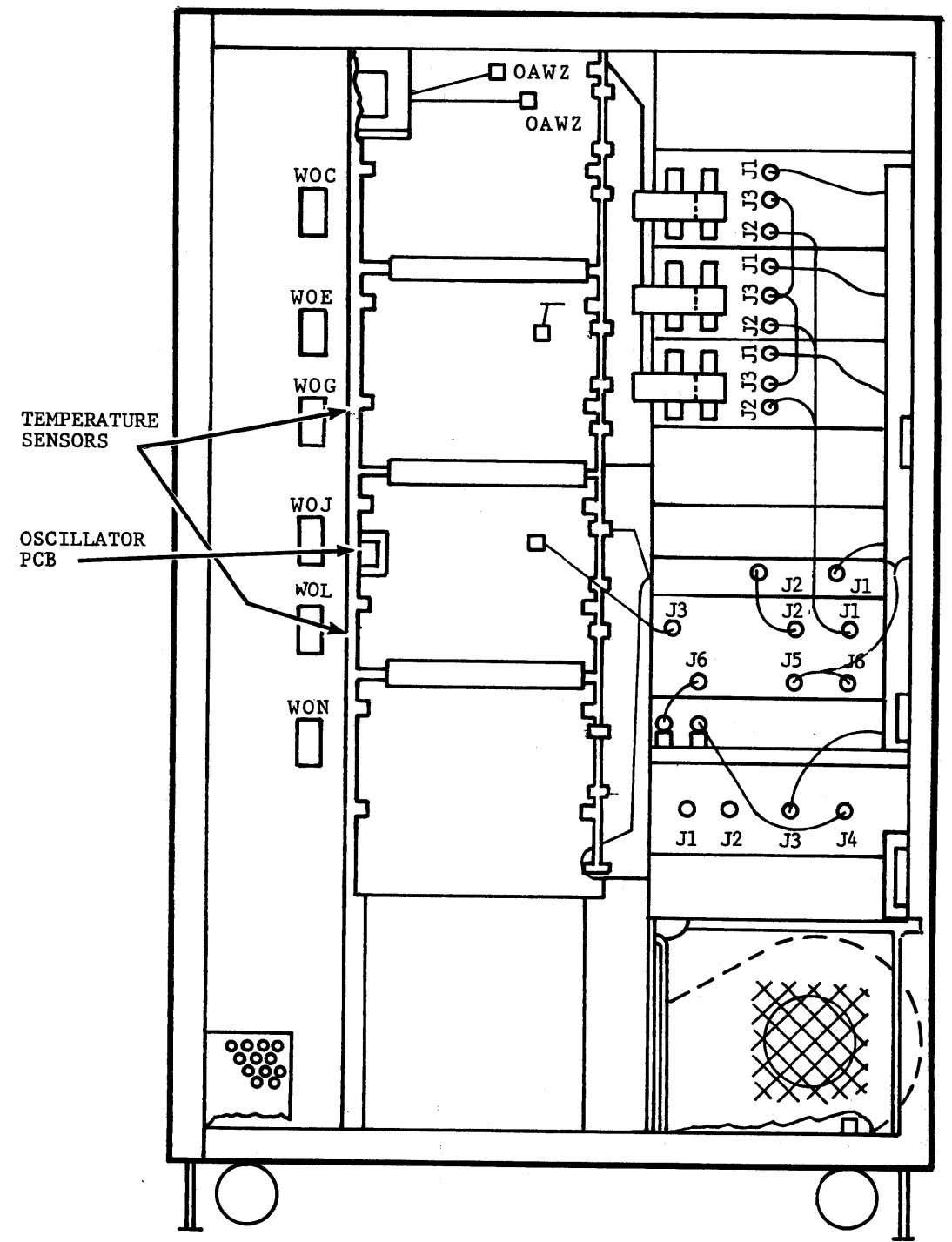

BACK VIEW  
POWER AND LOGIC  
MODULE DOORS REMOVED

HONEYWELL CONFIDENTIAL AND PROPRIETARY

Cabinet Zones and Locations

Figure 1-6

COMPONENT DESIGNATOR	ZONE	DESCRIPTION
ZMI/Z01	Bottom portion Zone V	Blower control assembly and blowers
ZN1	Left from lower position Zone V	Airflow sensor and switch assembly
S01	Lower portion of Plenum Zone B	Site power connector terminal board (S01 TB1)
S02	V	Circuit Breaker Module, contains circuit breaker (S02 CB1) that applies power to the cabinet
S03	V	Power Entry Module with circuit breakers (S03-CB2/CB3) for FAN and REG. power on/off control
VC1	V	Power Control Module with Power Control and Configuration switches and indicators
VD1	V	100 Watt Voltage Regulator
Plenum	B	Force air column to circulate air over and around power supplies and logic boards
Logic Buckets A0-A4	A	Logic card and backpanel area.
Depends on Type Cabinet and Options	W	Heat sensors area and special area depending on cabinet type CPU, MMU, or IOM requirements.

**HONEYWELL CONFIDENTIAL AND PROPRIETARY**

Components Common to all Cabinets  
Figure 1-7

Port Assignment	Store Size	Memory Addressed	Octal Addresses
0 A	0 (32K)	0-32K	0-100 000
	1 (64K)	0-64K	0-200 000
	2 (128K)	0-128K	0-400 000
	3 (256K)	0-256K	0-1 000 000
	4 (512K)	0-512K	0-2 000 000
	5 (1024K)	0-1024K	0-4 000 000
	6 (2048K)	0-2048K	0-10 000 000
	7 (4096K)	0-4096K	0-20 000 000
1 B	0 (32K)	32-64K	100 000-200 000
	1 (64K)	64-128K	200 000-400 000
	2 (128K)	128-256K	400 000-1 000 000
	3 (256K)	256-512K	1 000 000-2 000 000
	4 (512K)	512-1024K	2 000 000-4 000 000
	5 (1024K)	1024-2048K	4 000 000-10 000 000
	6 (2048K)	2048-4096K	10 000 000-20 000 000
	7 (4096K)	4096-8192K	20 000 000-40 000 000
2 C	0 (32K)	64-96K	200 000-300 000
	1 (64K)	128-192K	400 000-600 000
	2 (128K)	256-384K	1 000 000-1 400 000
	3 (256K)	512-768K	2 000 000-3 000 000
	4 (512K)	1024-1536K	4 000 000-6 000 000
	5 (1024K)	2048-3072K	10 000 000-14 000 000
	6 (2048K)	4096-6144K	20 000 000-30 000 000
	7 (4096K)	8192-12288K	40 000 000-60 000 000
3 D	0 (32K)	96-128K	300 000-400 000
	1 (64K)	192-256K	600 000-1 000 000
	2 (128K)	384-512K	1 400 000-2 000 000
	3 (256K)	768-1024K	3 000 000-4 000 000
	4 (512K)	1536-2048K	6 000 000-10 000 000
	5 (1024K)	3072-4096K	14 000 000-20 000 000
	6 (2048K)	6144-8192K	30 000 000-40 000 000
	7 (4096K)	12288-16384K	60 000 000-100 000 000
4 E	0 (32K)	128-160K	400 000-500 000
	1 (64K)	256-320K	1 000 000-1 200 000
	2 (128K)	512-640K	2 000 000-2 400 000
	3 (256K)	1024-1280K	4 000 000-5 000 000
	4 (512K)	2048-2560K	10 000 000-12 000 000
	5 (1024K)	4096-5120K	20 000 000-24 000 000
	6 (2048K)	8192-10240K	40 000 000-50 000 000
	7 (4096K)	---	---
5	0 (32K)	160-192K	500 000-600 000
	1 (64K)	320-384K	1 200 000-1 400 000
	2 (128K)	640-768K	2 400 000-3 000 000
	3 (256K)	1280-1536K	5 000 000-6 000 000
	4 (512K)	2560-3072K	12 000 000-14 000 000
	5 (1024K)	5120-6144K	24 000 000-30 000 000
	6 (2048K)	10240-12288K	50 000 000-60 000 000
	7 (4096K)	---	---
6	0 (32K)	192-224K	600 000-700 000
	1 (64K)	384-448K	1 400 000-1 600 000
	2 (128K)	768-896K	3 000 000-3 400 000
	3 (256K)	1536-1792K	6 000 000-7 000 000
	4 (512K)	3072-3584K	14 000 000-16 000 000
	5 (1024K)	6144-7168K	30 000 000-34 000 000
	6 (2048K)	12288-14336K	60 000 000-70 000 000
	7 (4096K)	---	---
7	0 (32K)	224-256K	700 000-1 000 000
	1 (64K)	448-512K	600 000-2 000 000
	2 (128K)	896-1024K	3 400 000-4 000 000
	3 (256K)	1792-2048K	7 000 000-10 000 000
	4 (512K)	3584-4096K	16 000 000-20 000 000
	5 (1024K)	7168-8192K	34 000 000-40 000 000
	6 (2048K)	14336-16384K	70 000 000-100 000 000
	7 (4096K)	---	---

Memory Port Mapping  
Figure 1-8

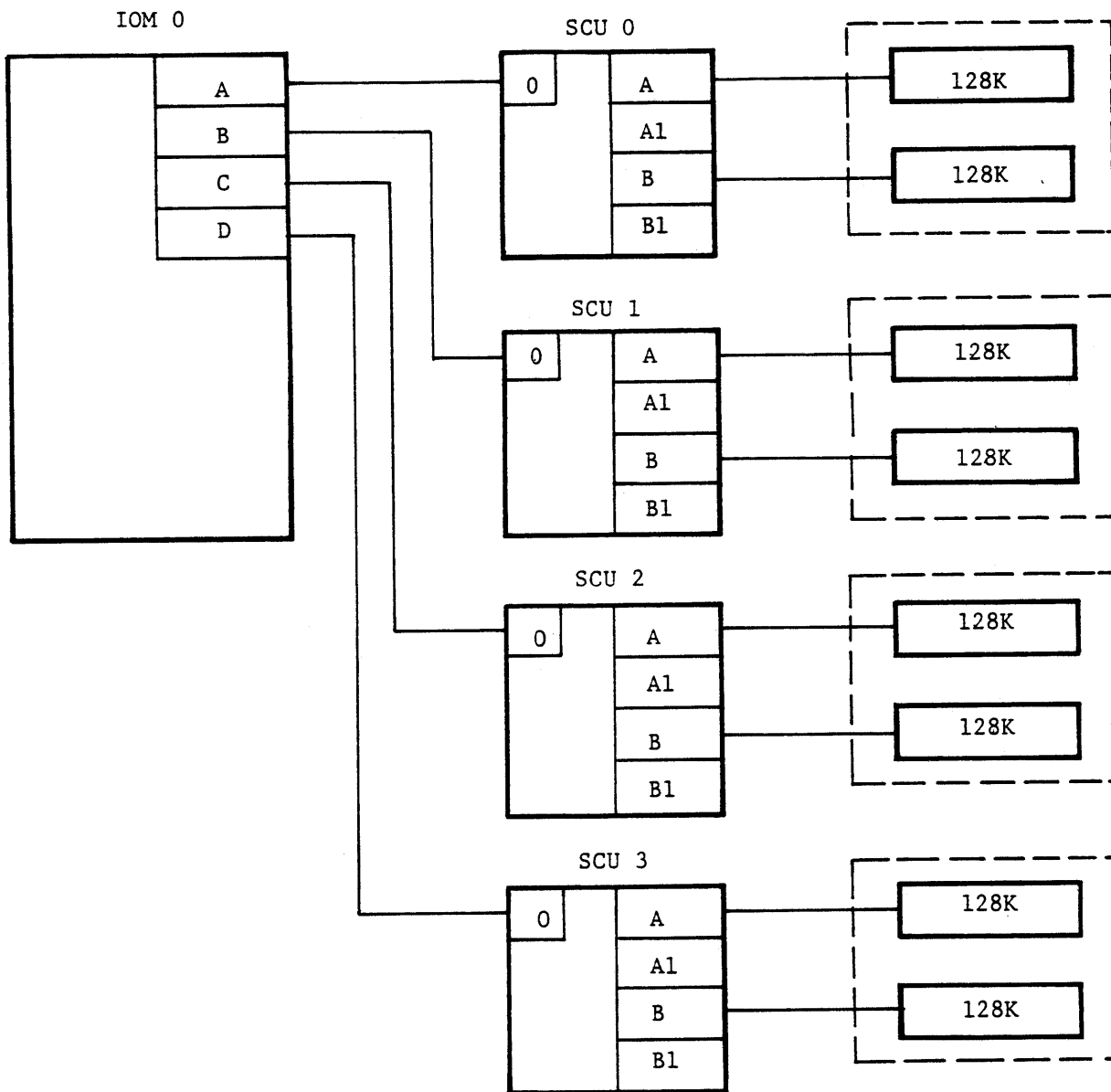

Site C Layout  
Figure 1-9

HONEYWELL CONFIDENTIAL AND PROPRIETARY

THIS PAGE INTENTIONALLY LEFT BLANK.

NOTE: THERE ARE NO REFERENCE  
MANUAL FIGURES FOR LESSON 2.

DPSE DPU

PRELIMINARY FIELD AUTO  
AND  
CPU SUBSET

*CPA E SMTCS A.3 or higher  
ETCOMP Firmware D or higher*

DISKETTES

SMTCS  
SYSTEM MAINTENANCE  
AND TEST CONTROL  
SOFTWARE DPU operat.

CPUAX  
AUTO EXEC AND INDEX  
Test set + every inst.

LIBRARY  
CPU SUBSET = 8  
DISKETTES 235 tests

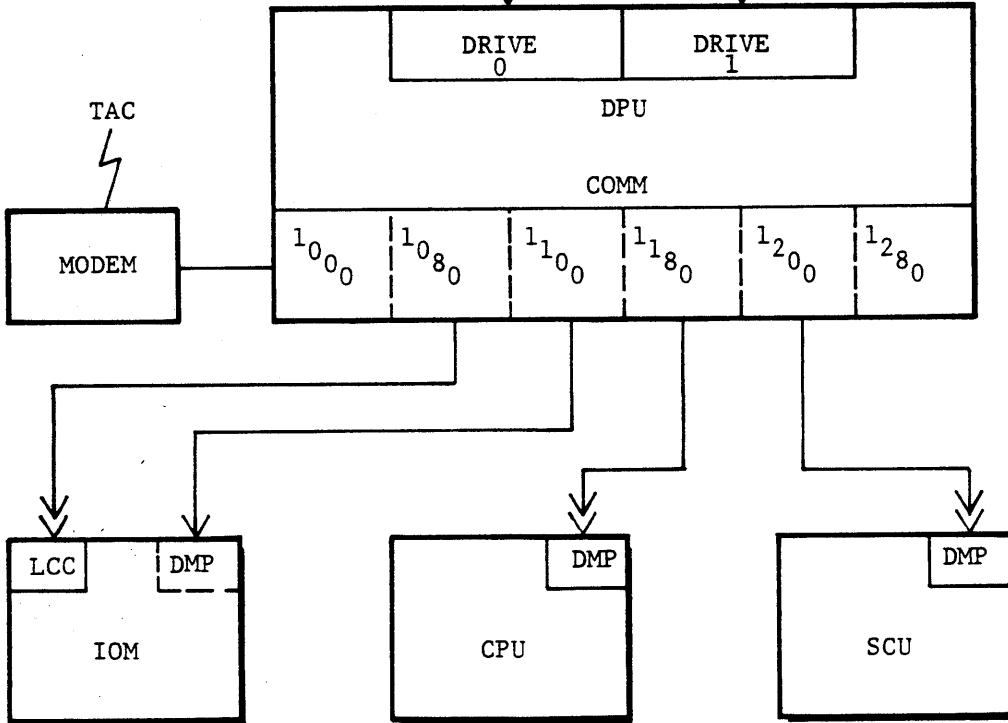
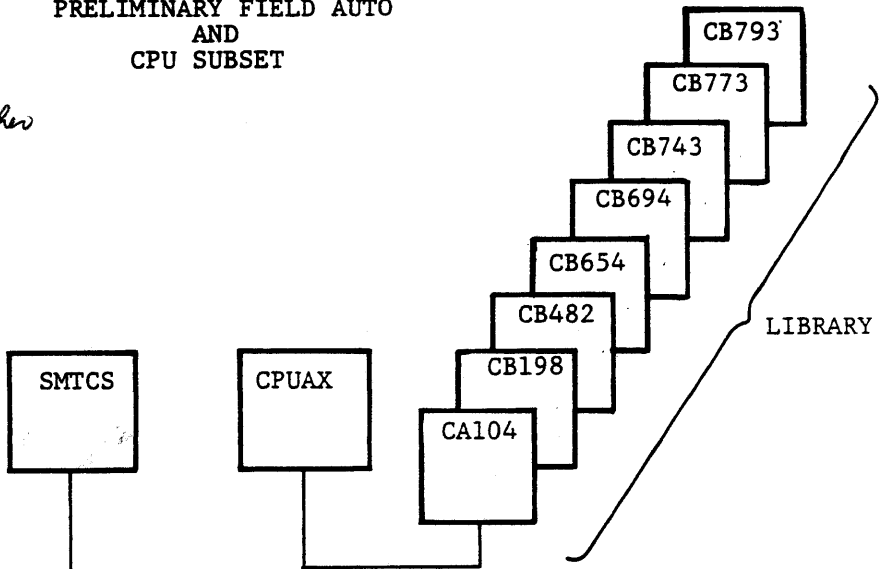

HONEYWELL CONFIDENTIAL AND PROPRIETARY  
Field Auto and CPU Subset  
Figure 3-1

## AUTO FEATURES

(Preliminary Release A.3)

- Execute Sequence

- One test
- Test Series (individually specified)
- Test range (first through last specified)
- Combo of above

- Execute Options

REPEAT LAST TEST SEQUENCE 1 TIME  
TERMINATE AUTO  
SAVE DMP STATE AND TERMINATE AUTO  
ERROR DISPLAY SUPPRESS  
STATUS OF MODES (OPTIONS)  
DISPLAY TEST INDEX  
RE-INITIALIZE DMP  
SUPPRESS ALL DISPLAY

SINGLE STEP (NOT IMPLEMENTED)

CONTINUOUS SEQUENCE REPEAT - BYPASS INPUTS

- Error Display

- Failing command pair
- Line Number (Listing Ref)
- Was Data  
Should Be Data  
Compare Mask

Figure 3-2

HONEYWELL CONFIDENTIAL AND PROPRIETARY



(All operator inputs are underlined in the following dialoss).

\*\*\* DIAGNOSTIC PROCESSOR UNIT REV A.3 (DL6.07) \*\*\*

RMI ACTIVE

C? AUT CPUDD  
WORKING...  
MOUNT DISKETTE ^CPUAX *drive 1*  
CARRIAGE RETURN WHEN READY OR @ TO QUIT  
(CARRIAGE RETURN)  
ENTER TEST SEQUENCE

?  
THE TEST SEQUENCE INPUT MAY BE FOR A SINGLE TEST:  
A200  
FOR SEVERAL TESTS:  
A200,A205,A210,A210,A209  
FOR A GROUP OF TESTS:  
A200-A210  
OR FOR A COMBINATION OF THE ABOVE REQUESTS:  
A200-A205,A209,A211-A215

THE ABBREVIATION FOR ANY ONE OF THE FOLLOWING OPTIONS  
MAY BE ENTERED INSTEAD OF A TEST SEQUENCE.

REPEAT	(R)	REPEAT LAST TEST SEQUENCE 1 TIME
QUIT	(Q)	TERMINATE AUT
SUSPEND	(S)	SAVE DMP STATE AND TERMINATE AUT
(BREAK)		TERMINATE AUT
ERR SUPP	(.E)	ERROR DISPLAY SUPPRESS (TOGGLE)
MODE STAT	(.M)	STATUS OF MODE FLAGS
LIST INDX	(.X)	DISPLAY TEST INDEX
INIT DMP	(.I)	RE-INITIALIZE DMP
PRT OFF	(.P)	SUPPRESS ALL DISPLAY
CONTINUE Y OR N	- Y	
STEP	(.S)	SINGLE STEP (NOT IMPLEMENTED)
LOOP	(.L)	CONTINUOUS SEQUENCE REPEAT - BYPASS INPUTS

LOOP OPTIONS: (MUTUALLY EXCLUSIVE)

RESTART	(.R)	RESTART SEQUENCE AT BEGINNING (DEFAULT)
CONTINUE	(.C)	CONTINUE TEST SEQUENCE WITH SAME TEST
NEXT TEST	(.N)	CONTINUE TEST SEQUENCE WITH NEXT TEST
(BREAK)		TERMINATE LOOP OPTION

ENTER TEST SEQUENCE

Auto Test Initiation  
Figure 3-3

REV. 1

HONEYWELL CONFIDENTIAL AND PROPRIETARY

\*\*\*\*

\* A104 REV. A CPU 01/30/81

\* A104 REV. C2 CPU 12/10/80 \*\*\* HONEYWELL PROPRIETARY \*\*\*

\* CHECK DIS  
\* CHECK CU CYCLE

```

*****
0002      DCL      %STRD,D;
0003      DCL      %STRSW,D;
0004      DCL      WRTBUF,"100"D;
0005      CONTROL  INCL;
0006      CONTROL  RESET;
0007      CONTROL  STCL;
0008      WRITE    ADSTOP,0;
0009      CONTROL  STCU;          STEP CYCLE-CU
0010      WRITE    DATA,77777777277; DATA SWS-77777777277
0011      CONTROL  EXSWCO;       EXECUTE-IN/OUT
0012      CONTROL  WAIT,1;
0013      READ     IWR,Y,%STRD;   ADDRESS,CU 77777
0014      COMPARE  %STRD,7777777727700000000000,, "E0";
0015      READ     STAT,%STRD;    DIS         OFF
0016      COMPARE  %STRD,000400000000000000000000,
0017                        037600000000000000000000, "E0";
*
0018      CONTROL  INCL;          INIT & CLR-IN/OUT
0019      CONTROL  WAIT,1;
0020      READ     STAT,%STRD;    DIS         ON
0021      COMPARE  %STRD,010000000000000000000000,, "E0";
*****
0022      ENDTEST;

```

HONEYWELL CONFIDENTIAL AND PROPRIETARY  
Sample Test Listing  
Figure 3-4

ENTER TEST SEQUENCE  
A100  
TEST NOT IN DIRECTORY  
ENTER TEST SEQUENCE

*A100 not in d*

ENTER TEST SEQUENCE  
A104  
A104 A *Test ID + Rev.*  
*^CA104>A104 Diskette Vol. + Test File*  
MOUNT DISKETTE ^CA104  
CARRIAGE RETURN WHEN READY OR I TO IGNORE  
I (or 3 unsuccessful retries)  
TEST NOT FOUND ^CA104>A104  
ENTER TEST SEQUENCE

**HONEYWELL CONFIDENTIAL AND PROPRIETARY**

Test Sequence Execution  
Figure 3-5  
Sheet 1 of 2

```

ENTER TEST SEQUENCE
A104
A104  A
^CA104>A104
  MOUNT DISKETTE ^CA104
  CARRIAGE RETURN WHEN READY OR I TO IGNORE
  (carriage return)
* A104 REV. A CPU 12/11/80  ID, Rev, date of Test
  TEST ERROR
^CA104>A104  Path name
  READ IWRY,%STRRD;
  COMPARE %STRRD,77777777277000000000000000,, "E0";
  LINE NO IS          0014
  WAS DATA IS        000000000000000000000000000000
  SHOULD BE DATA IS  7777777727700000000000000000
  MASK DATA IS       7777777777777777777777777777
  CONTINUE Y OR N

Y
  TEST ERROR
^CA104>A104
  READ STAT
  READ STAT,%STRRD;
  COMPARE %STRRD,0100000000000000000000000000,, "E0";
  LINE NO IS          0021
  WAS DATA IS        000000000000000000000000000000
  SHOULD BE DATA IS  010000000000000000000000000000
  MASK DATA IS       7777777777777777777777777777
  CONTINUE Y OR N

N
ENTER TEST SEQUENCE

```

*Cross Ref. Test Listing*

**HONEYWELL CONFIDENTIAL AND PROPRIETARY**

Test Sequence Execution  
 Figure 3-5  
 Sheet 2 of 2

THE ABBREVIATION FOR ANY ONE OF THE FOLLOWING OPTIONS  
MAY BE ENTERED INSTEAD OF A TEST SEQUENCE.

REPEAT	(R)	REPEAT LAST TEST SEQUENCE 1 TIME
QUIT	(Q)	TERMINATE AUT
SUSPEND	(S)	SAVE DMP STATE AND TERMINATE AUT
(BREAK)		TERMINATE AUT
ERR SUPP	(.E)	ERROR DISPLAY SUPPRESS (TOGGLE) NOTE (A)
MODE STAT	(.M)	STATUS OF MODE FLAGS
LIST INDX	(.X)	DISPLAY TEST INDEX
INIT DMP	(.I)	RE-INITIALIZE DMP <i>Hung up</i>
PRT OFF	(.P)	SUPPRESS ALL DISPLAY
CONTINUE Y OR N	- Y	
STEP	(.S)	SINGLE STEP (NOT IMPLEMENTED)
LOOP	(.L)	CONTINUOUS SEQUENCE REPEAT - BYPASS INPUTS

LOOP OPTIONS: (MUTUALLY EXCLUSIVE)

RESTART	(.R)	RESTART SEQUENCE AT BEGINNING (DEFAULT)
CONTINUE	(.C)	CONTINUE TEST SEQUENCE WITH SAME TEST
NEXT TEST	(.N)	CONTINUE TEST SEQUENCE WITH NEXT TEST
(BREAK)		TERMINATE LOOP OPTION
ENTER TEST SEQUENCE		

NOTE (A): EACH USE OF .E WILL ALTERNATELY TURN THE  
OPTION ON AND OFF.

HONEYWELL CONFIDENTIAL AND PROPRIETARY

Test Sequence Options  
Figure 3-6

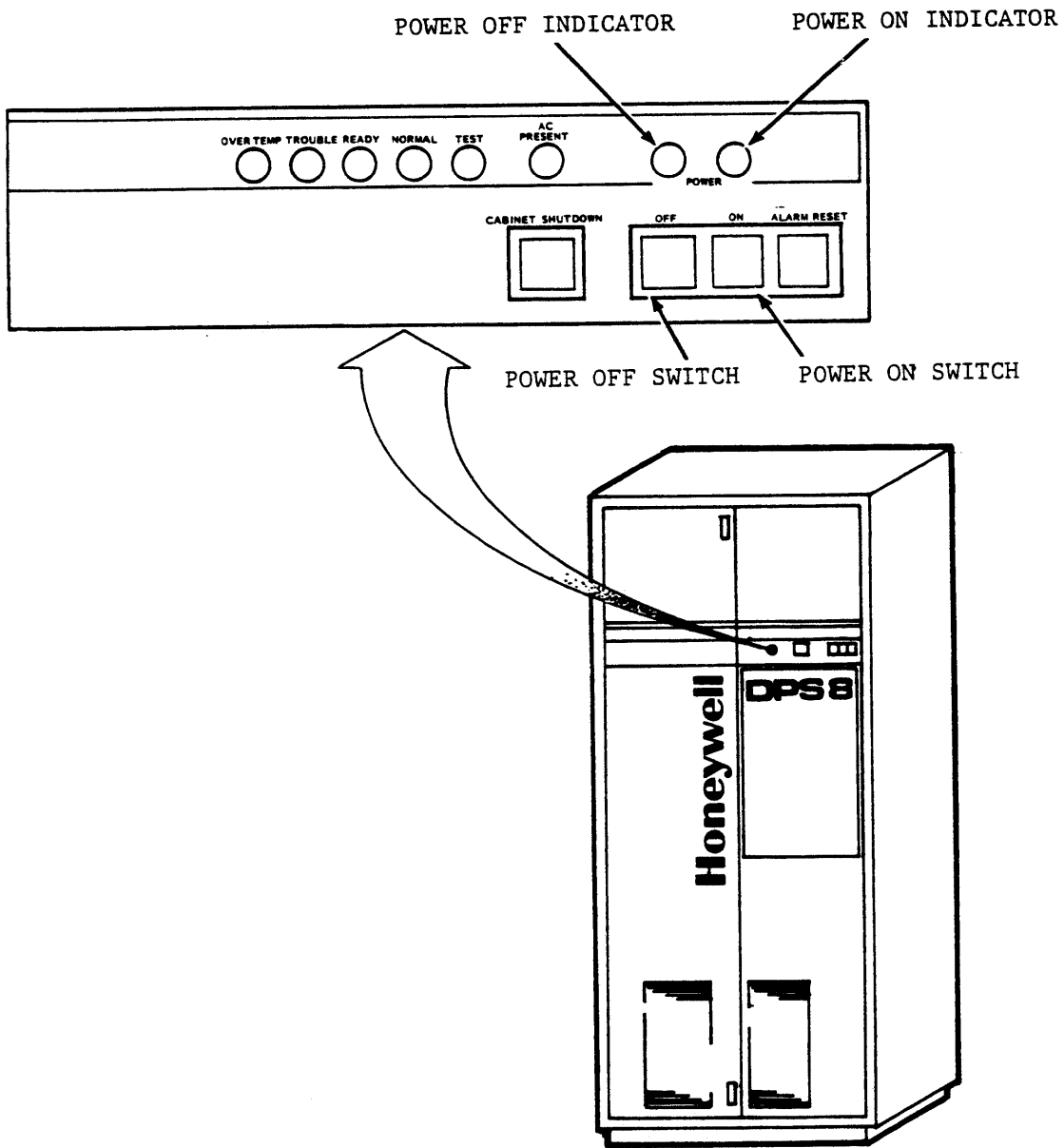

**HONEYWELL CONFIDENTIAL AND PROPRIETARY**

Operator Panel  
Figure 4-1

**POWER AND CONFIGURATION**

**Input/Output Multiplexer**

1. Set the Input/Output Multiplexer cabinet AC circuit breaker **①** to the ON position.
2. Verify that the AC PRESENT and POWER OFF indicators **②** are illuminated.
3. Ensure that the Master Power Regulator (VF1) OFF-REMOTE switch **③** is in the REMOTE position.

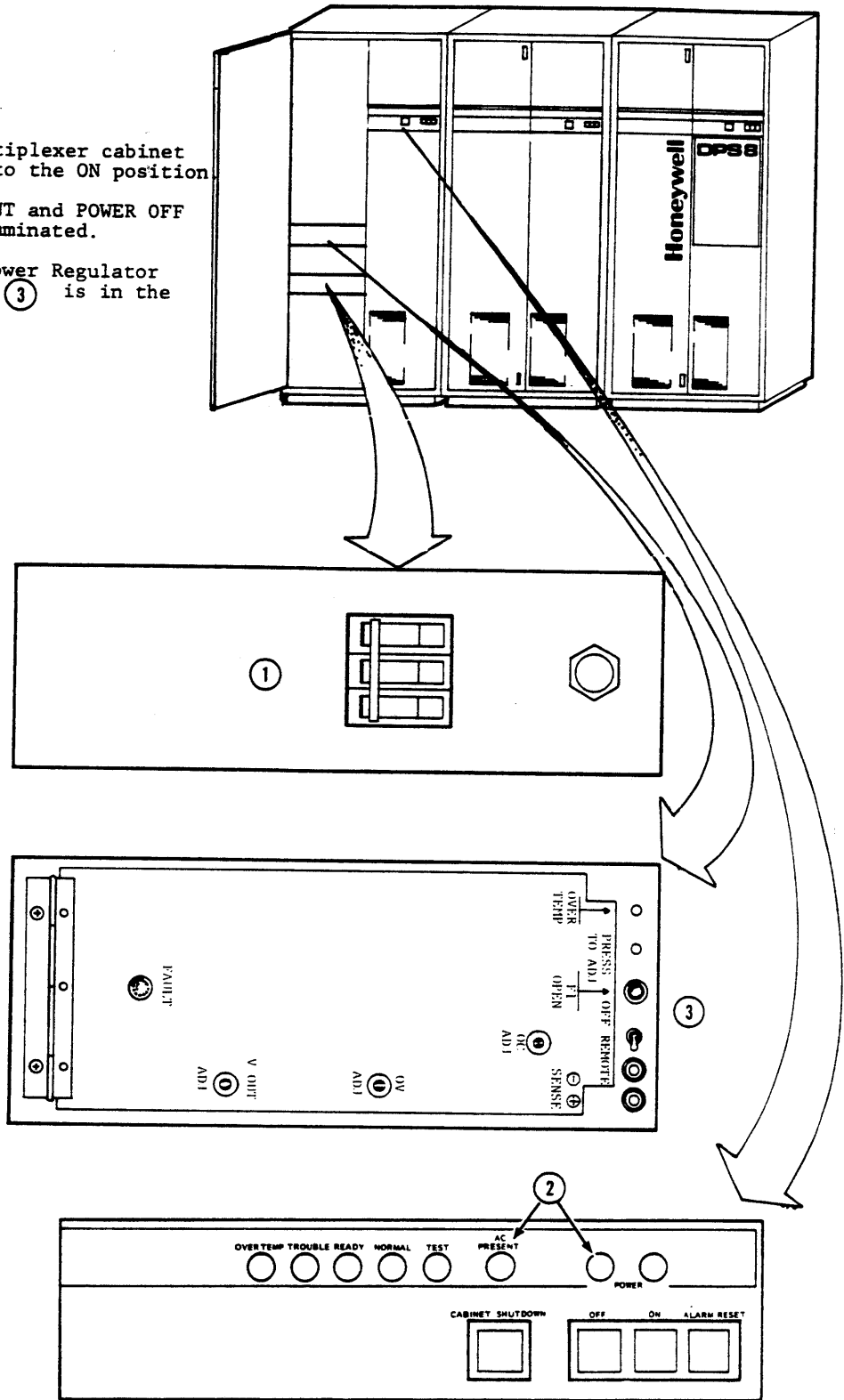

**HONEYWELL CONFIDENTIAL AND PROPRIETARY**

Power On Sequence

Figure 4-2

Sheet 1 of 3

(Continued)

4. Ensure that the Margins and Power Control LOCAL-REMOTE switches (1) are in the REMOTE position.
5. Set the FAN and REGULATORS circuit breakers (CB3, CB2) (2) to the ON position.
6. Ensure that the CABINET SHUTDOWN switch (3) is in the OUT position.

NOTE: PRESS AND RELEASE THE CABINET SHUT-DOWN SWITCH TO FULFILL THE REQUIRE-MENT.

7. Press and release the POWER ON switch (4)
8. Verify that the POWER ON (5) and the DC CONF., DC ON (6) indicators are illuminated.

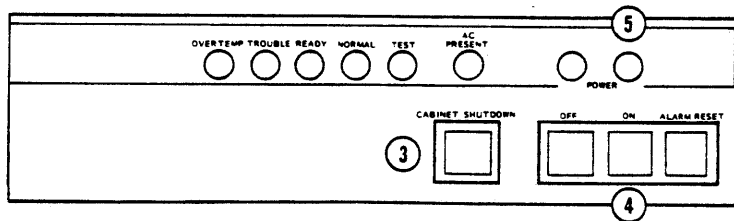
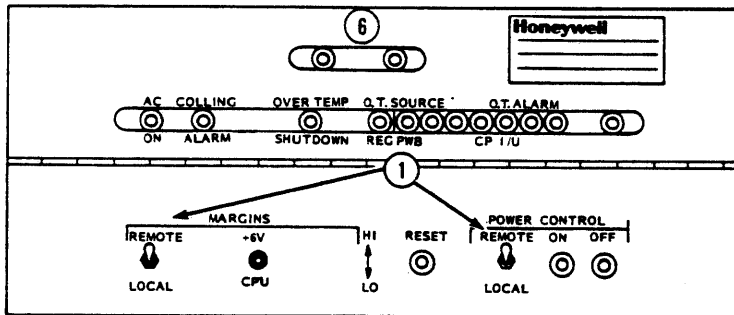
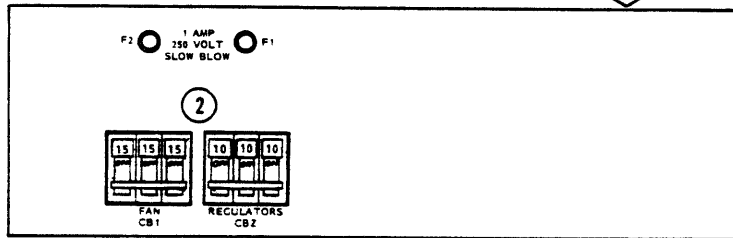
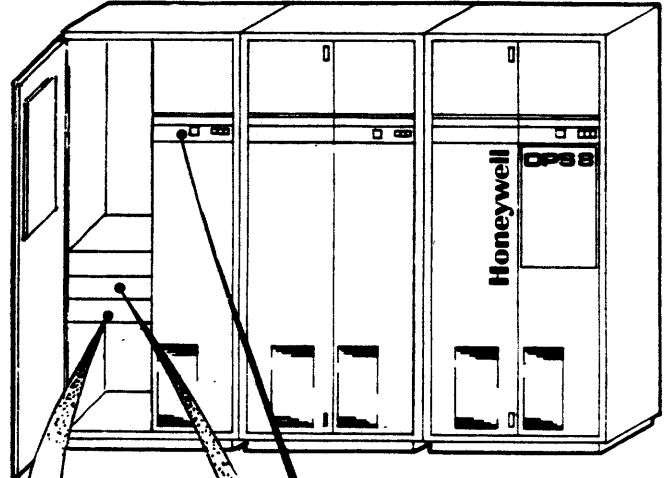

HONEYWELL CONFIDENTIAL AND PROPRIETARY

Power On Sequence  
Figure 4-2  
Sheet 2 of 3



(Continued)

9. Verify that the POWER OFF indicator <sup>①</sup> is extinguished.
10. Verify that the TROUBLE indicator <sup>②</sup> extinguishes and the READY indicator <sup>②</sup> becomes illuminated after approximately three seconds.

NOTE: FAILURE OF ANY PROCEDURAL STEP REQUIRES CAREFUL NOTING OF THE FAULT SYMPTOM AND, AT THE DISCRETION OF THE SUPERVISOR, CONTACTING TAC FOR TECHNICAL ASSISTANCE. (SEE PARAGRAPH 4.1, PRIOR TO CALLING THE RESPONSE CENTER)

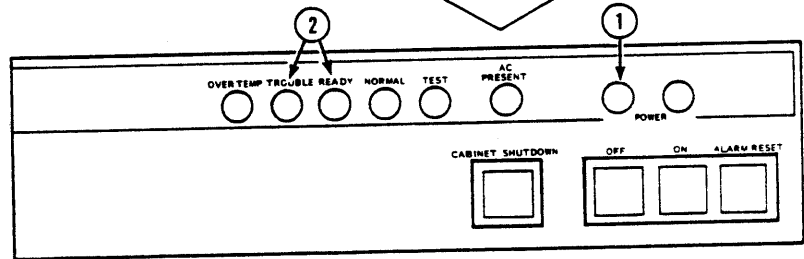
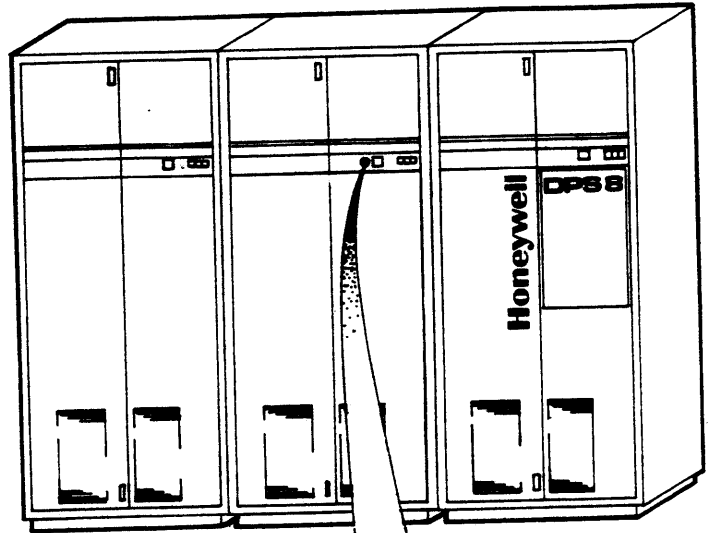

**HONEYWELL CONFIDENTIAL AND PROPRIETARY**

Power On Sequence  
Figure 4-2  
Sheet 3 of 3

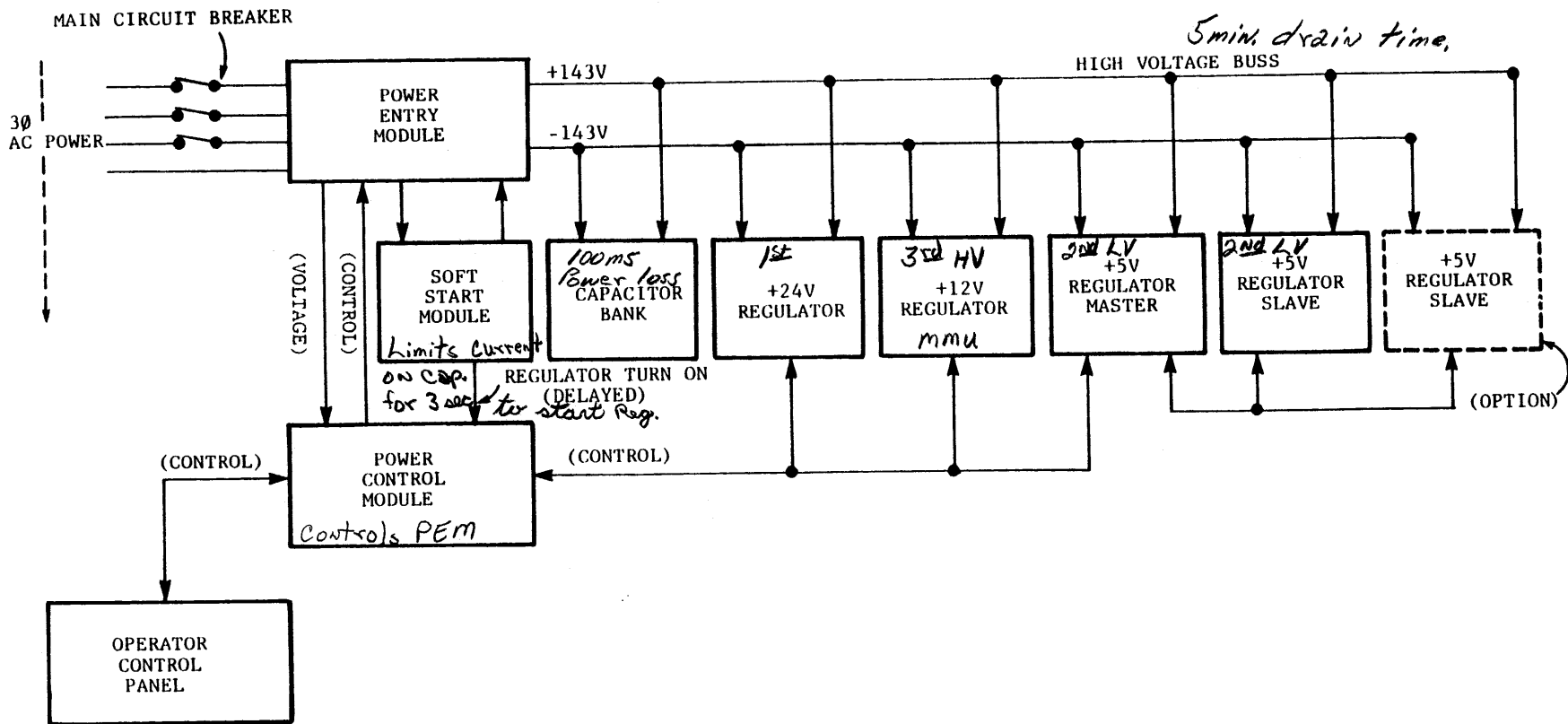

HONEYWELL CONFIDENTIAL AND PROPRIETARY

Power System Overview

Figure 4-3

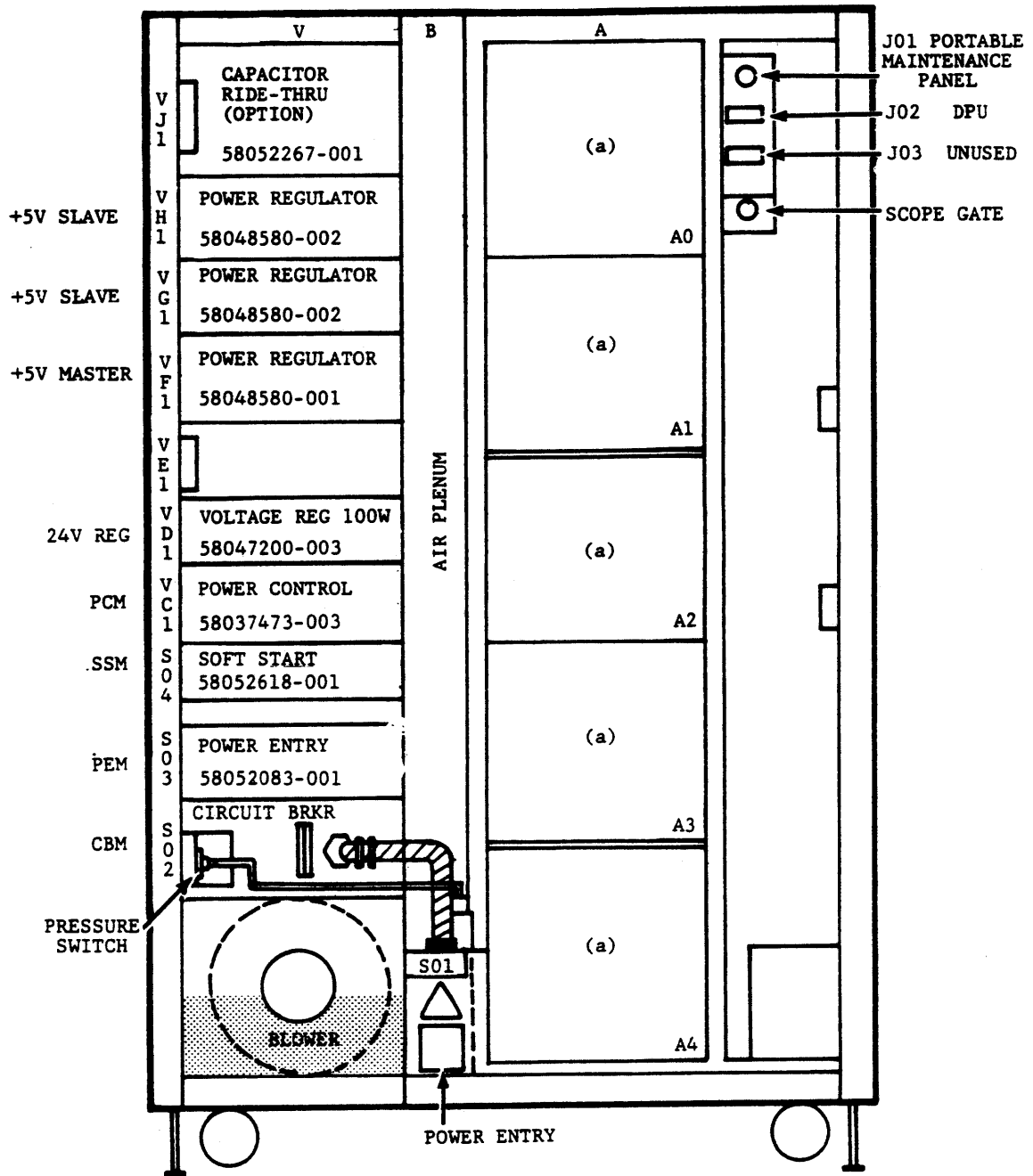

TYPICAL INPUT/OUTPUT MULTIPLEXER (IOM) UNIT  
FRONT VIEW (DOORS REMOVED)

HONEYWELL CONFIDENTIAL AND PROPRIETARY

IOM Power Modules  
Figure 4-4

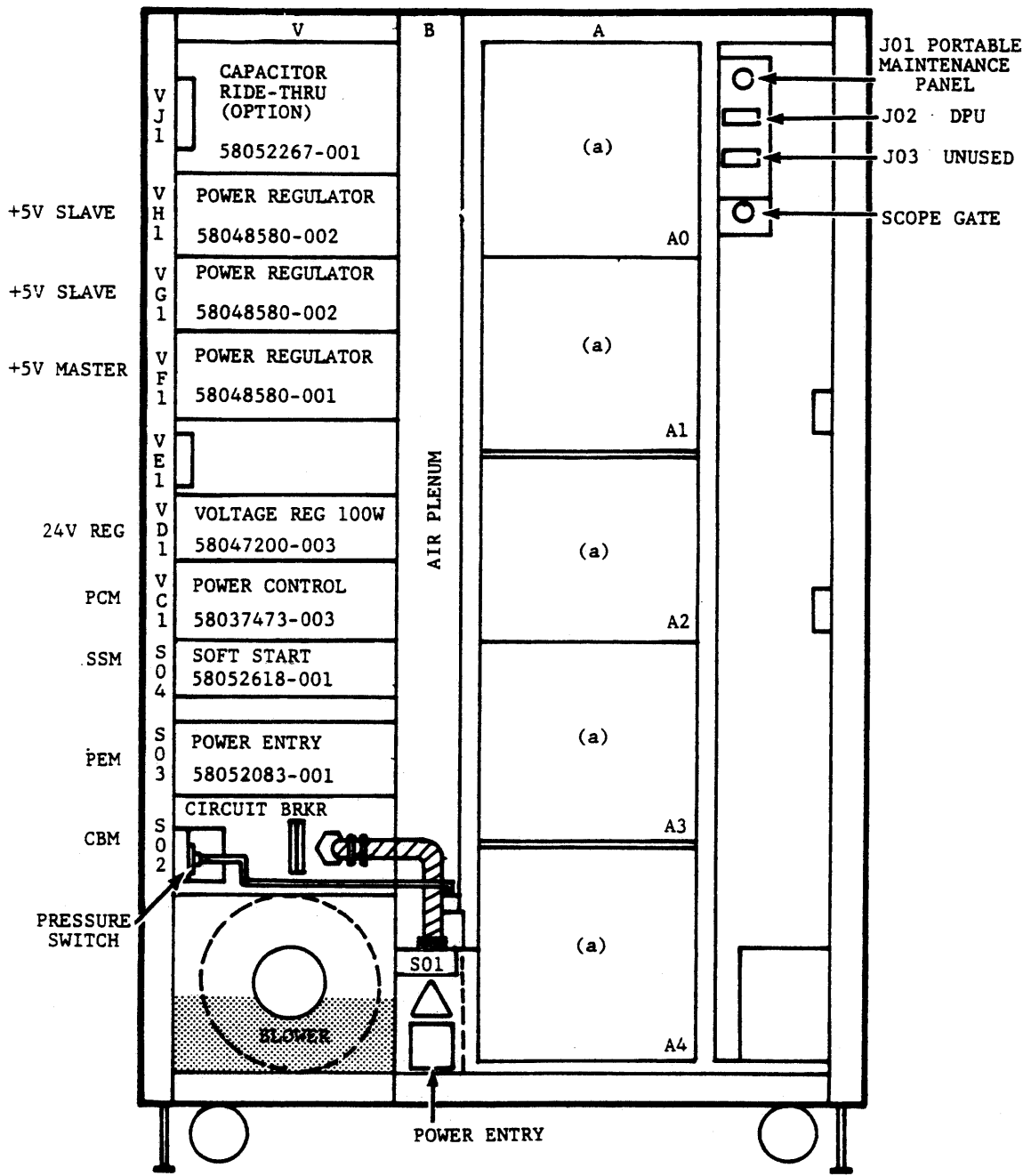

TYPICAL CENTRAL PROCESSOR UNIT (CPU)  
FRONT VIEW (DOORS REMOVED)

HONEYWELL CONFIDENTIAL AND PROPRIETARY

CPU Power Modules  
Figure 4-5

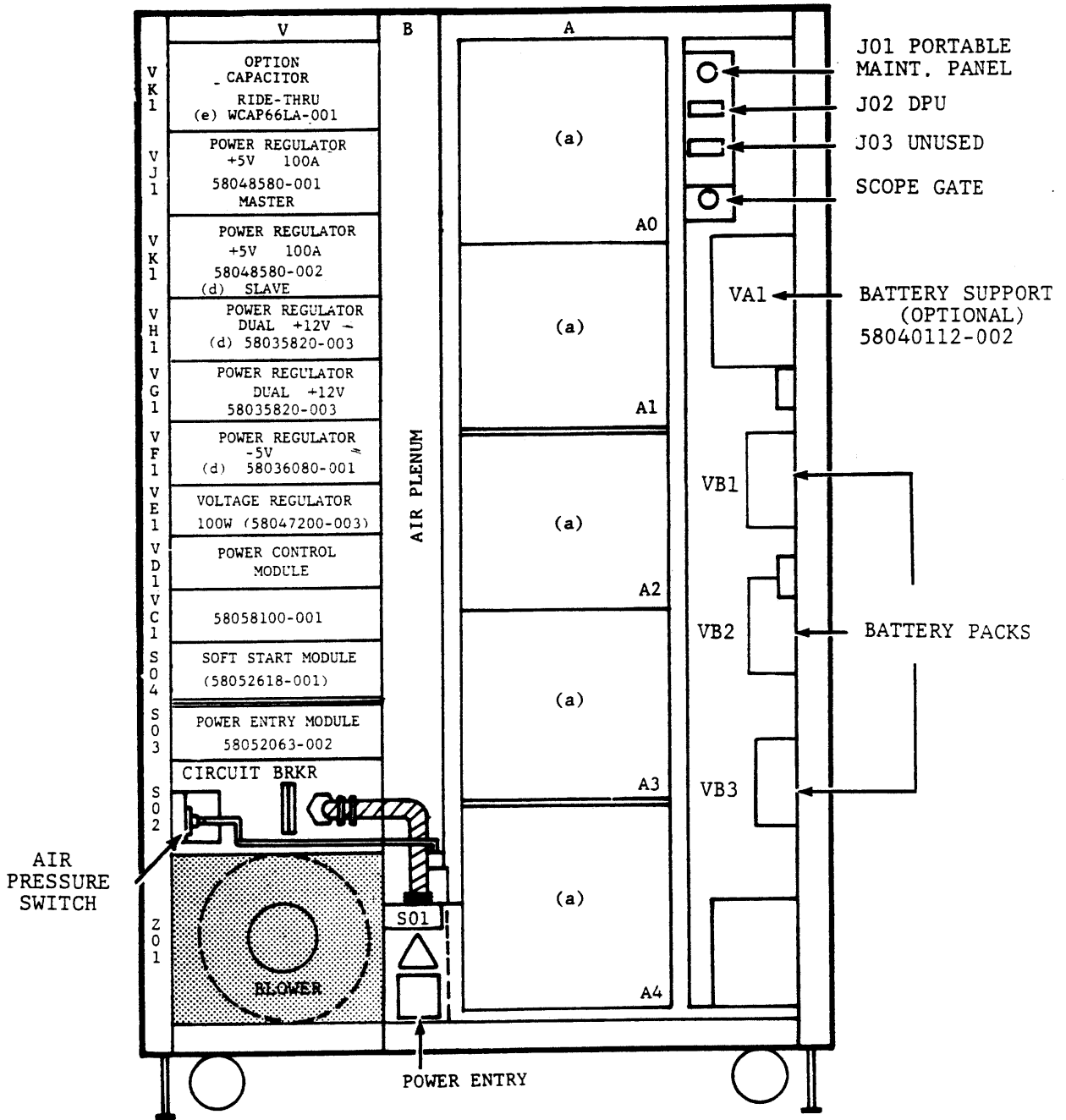

TYPICAL MAIN MEMORY UNIT (MMU)  
FRONT VIEW (DOORS REMOVED)

**HONEYWELL CONFIDENTIAL AND PROPRIETARY**

MMU Power Modules  
Figure 4-6

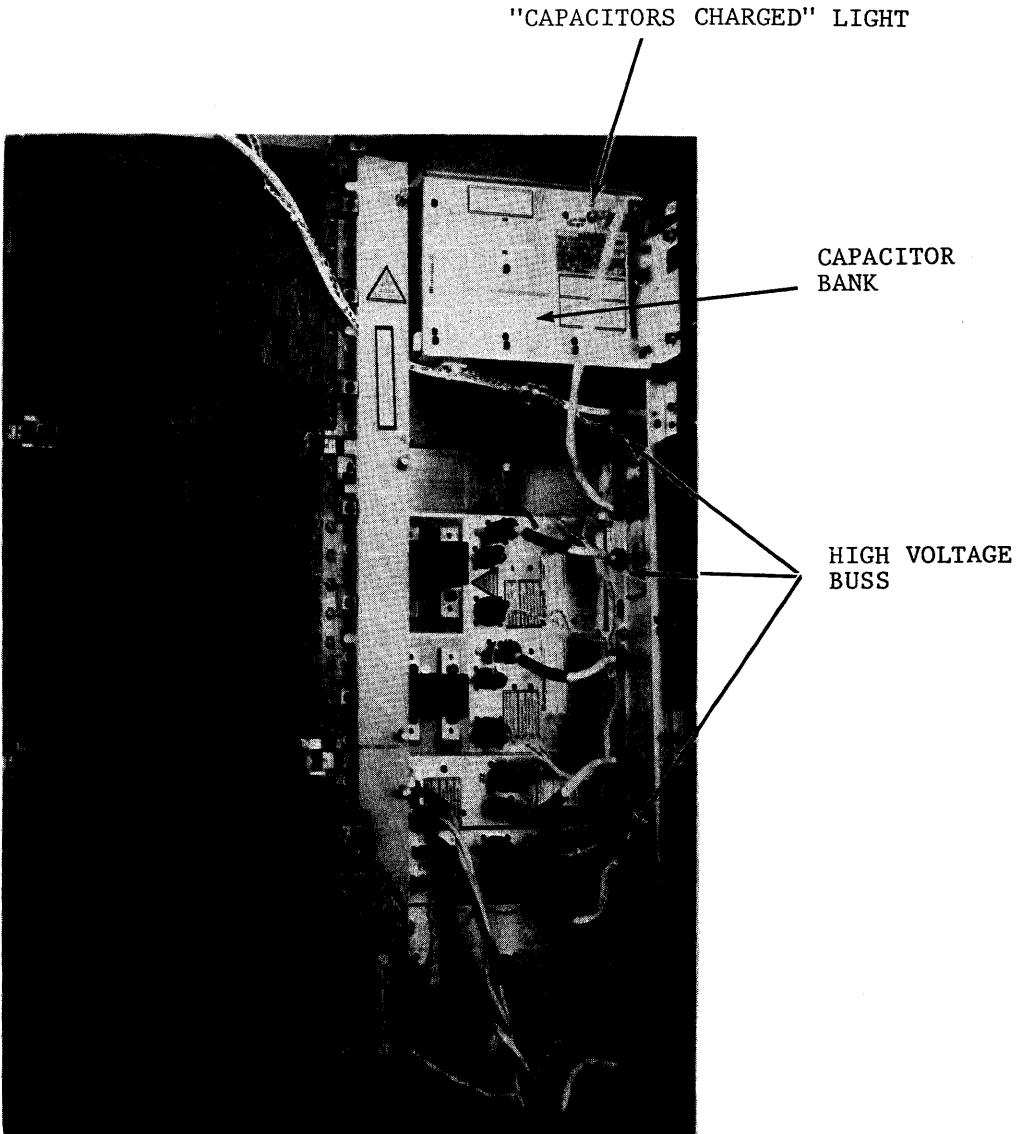

RIGHT REAR VIEW

High Voltage Buss  
Figure 4-7

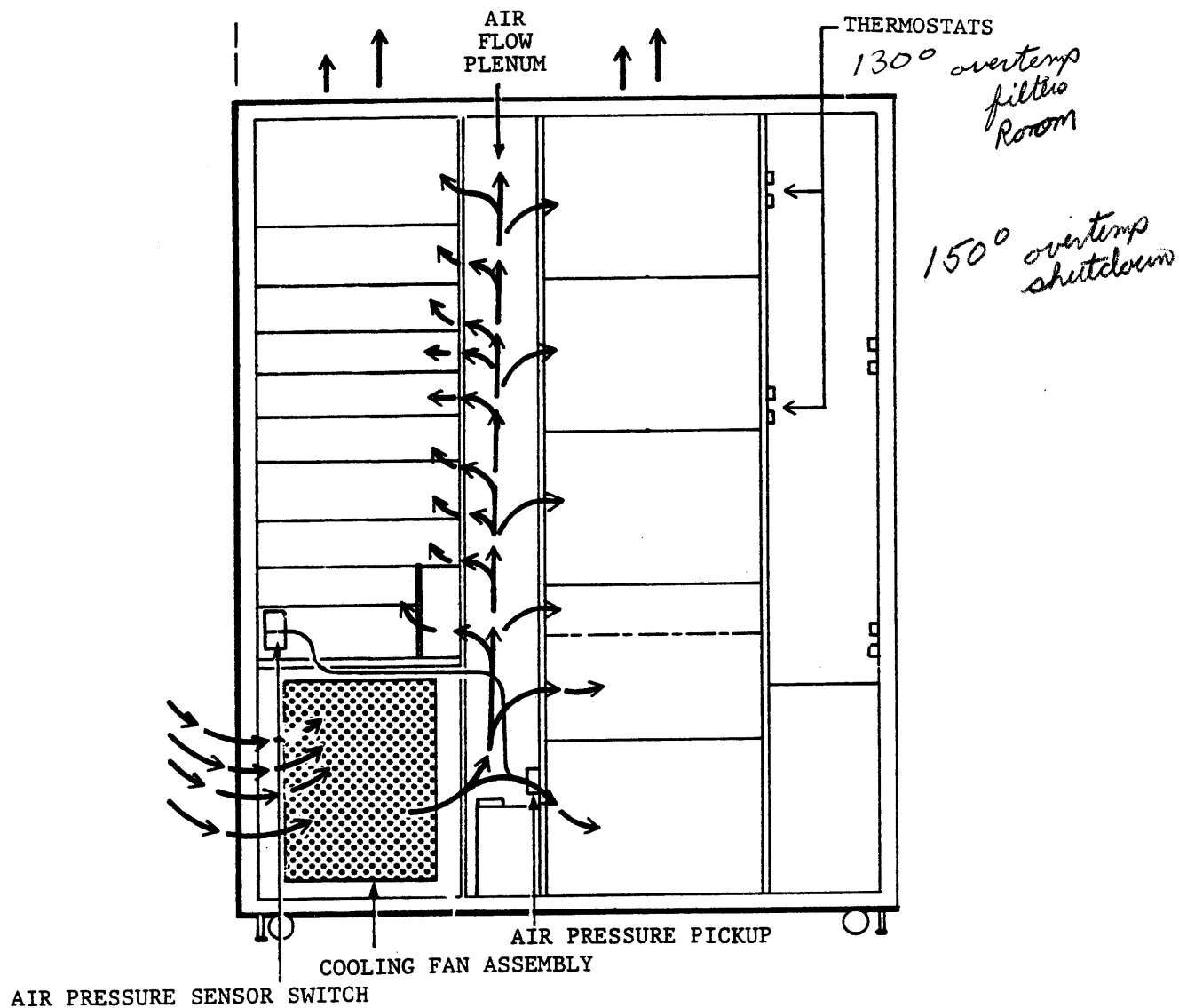

IOU/MMU/CPU CABINET AIRFLOW  
FRONT VIEW (WITHOUT DOORS)

**HONEYWELL CONFIDENTIAL AND PROPRIETARY**

Cabinet Airflow  
Figure 4-8

CONDITIONS: Logic area in the CPU is getting too warm. System is still operable.  
The audio alarm just turned on.

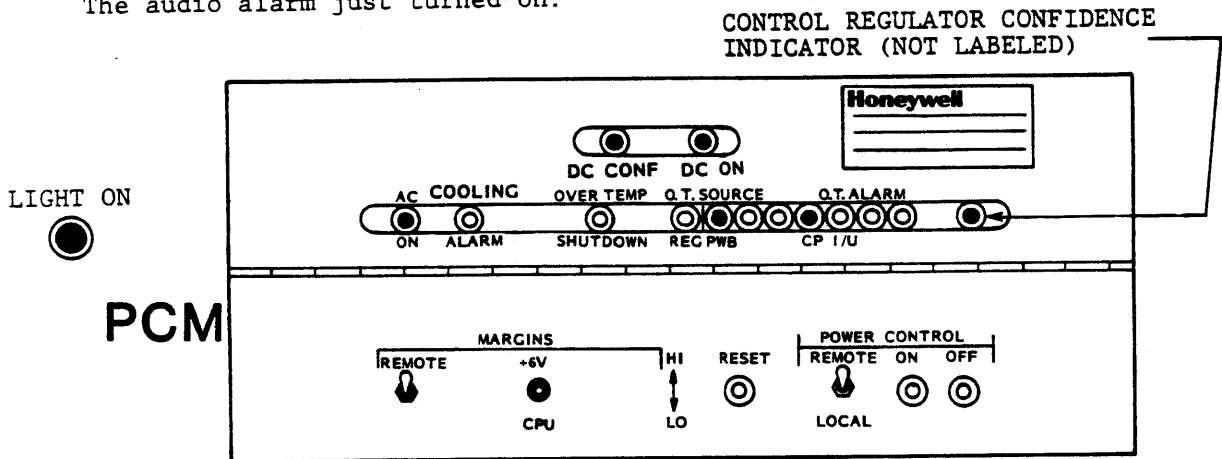

CONDITIONS: The +5V Master Regulator is getting too warm. System is still operational.  
The audio alarm just turned on.

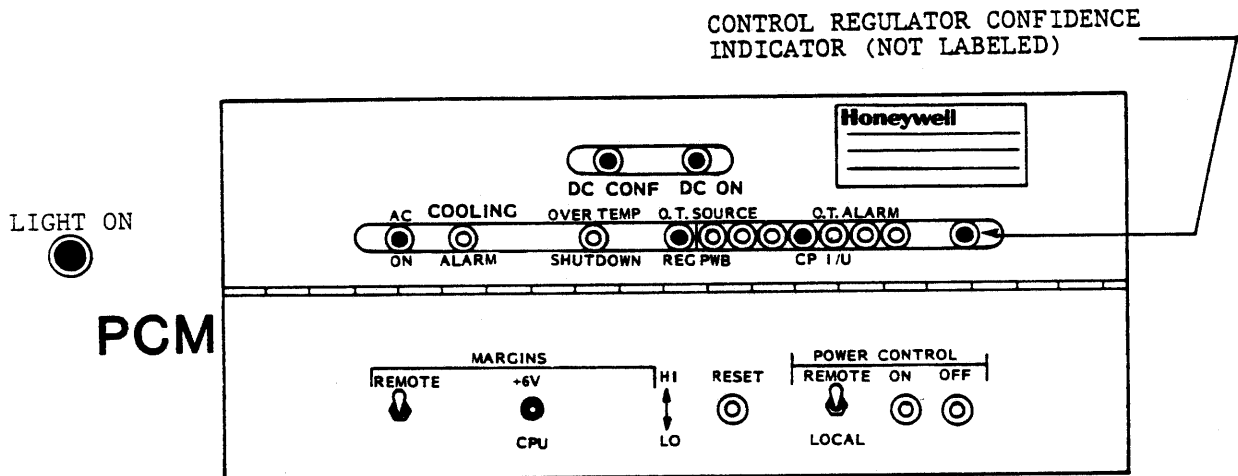

**HONEYWELL CONFIDENTIAL AND PROPRIETARY**  
Examples of Overtemperature Alarm Indications  
Figure 4-11  
Sheet 1 of 2



CONDITIONS: Audio alarm sounds.  
 D.C. power has just dropped.  
 +5V Master regulator is extremely hot.

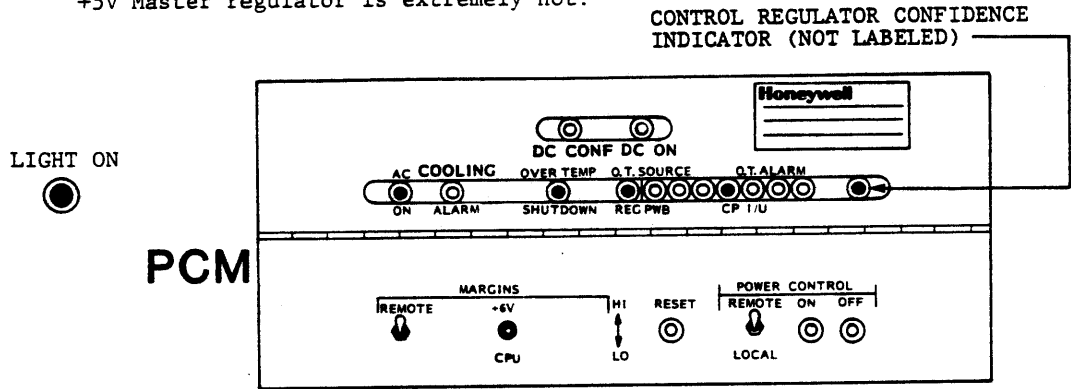

CONDITIONS: Audio alarm sounds.  
 D.C. power drops.  
 You arrive on site about an hour later.

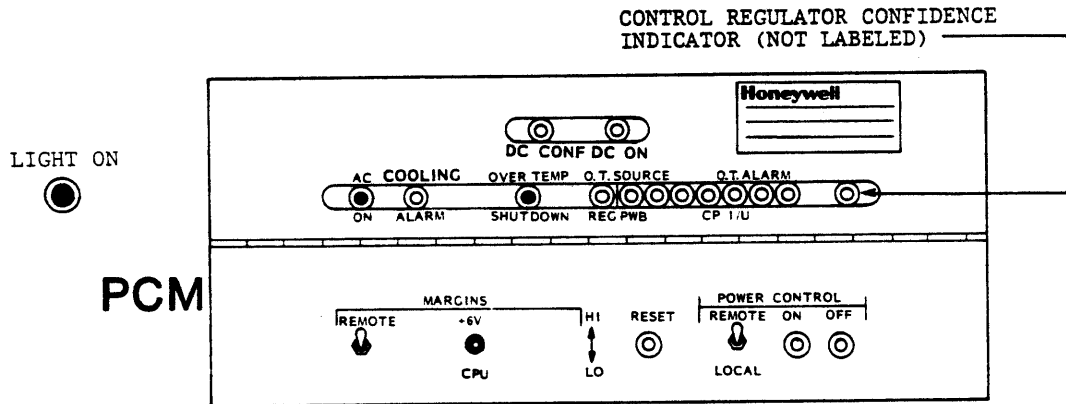

NOTE: THE OVERTEMPERATURE SOURCE AND ALARM INDICATORS ARE NOT LATCHED AND WILL TURN OFF WHEN THE UNIT COOLS OFF.

**HONEYWELL CONFIDENTIAL AND PROPRIETARY**  
 Examples of Overtemperature Shutdown Indicators  
 Figure 4-11  
 Sheet 2 of 2

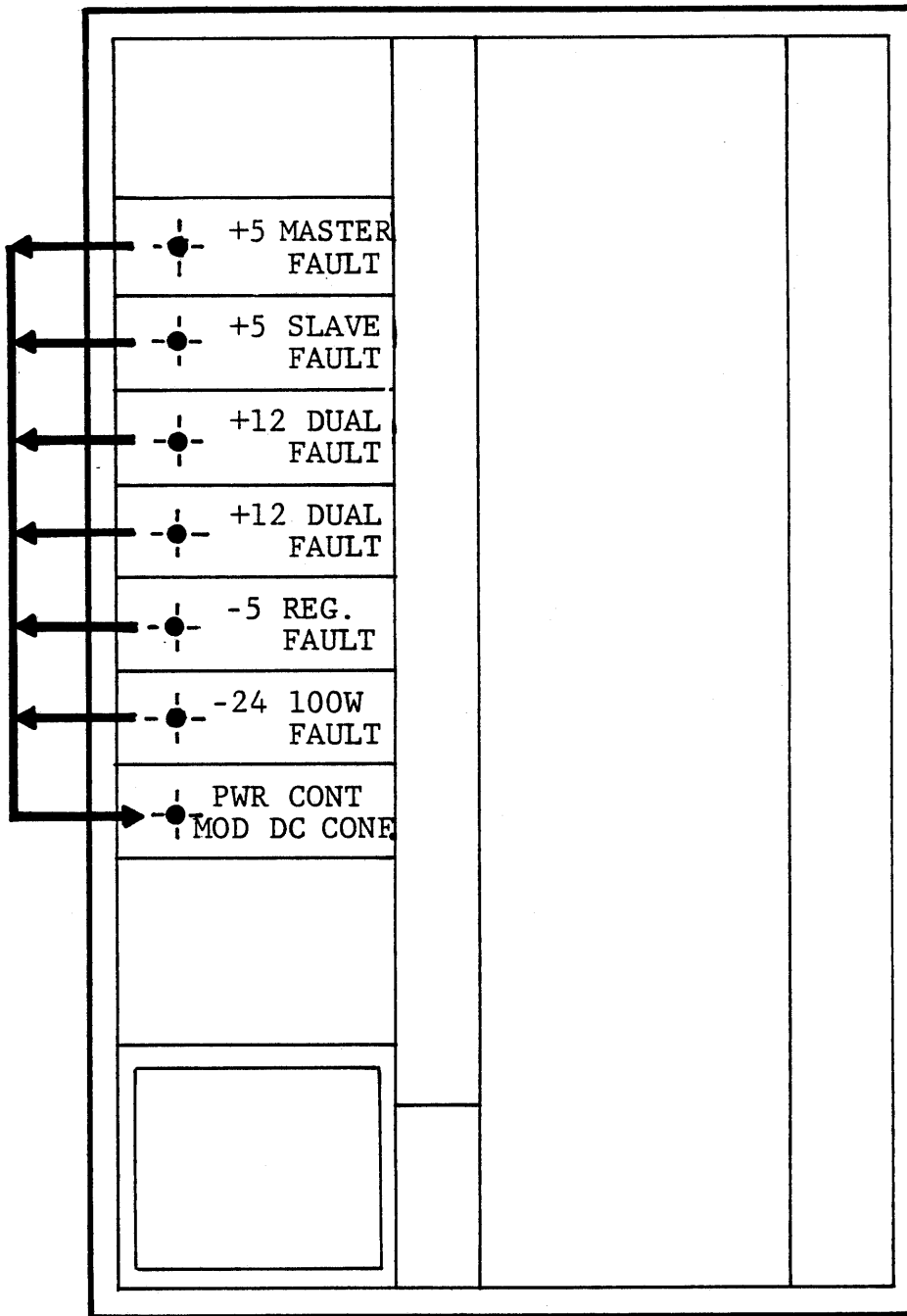

**HONEYWELL CONFIDENTIAL AND PROPRIETARY**  
 Power Faults/DC Confidence  
 Figure 4-12

#### 4.0 MAINTENANCE AIDS

##### 4.1 INTRODUCTION

These maintenance aids are part of the product maintenance documentation (PMD) for the DPS 8/52, DPS 8/62 and DPS 8/70 power and cooling systems in accordance with PMD Specification 58061028.

<b>WARNING</b>
----------------

HIGH CURRENT AND HIGH VOLTAGE SHOCK  
HAZARDS ARE PRESENT IN THE POWER SYSTEM.

1. NEVER CONNECT OR DISCONNECT POWER CABLES OR WIRING WHILE POWER IS ON.
2. WAIT AT LEAST FIVE MINUTES AFTER POWER IS OFF FOR THE CAPACITOR RIDE-THRU MODULE TO DISCHARGE BEFORE WORKING ON THE POWER SYSTEM.
3. OBSERVE AND OBEY ALL CAUTION AND WARNING SIGNS AND LABELS.

The maintenance aids are divided into two parts: The Power System and Cooling System. The power system maintenance aids include power regulator adjustment procedures and a power and cooling troubleshooting guide. Also included are checks for proper blower and air flow sensor switch operation.

The level of the maintenance aids is to the optimum replaceable unit (ORU), which is a module and/or a PWB, including fuses and other replaceable parts.

**HONEYWELL CONFIDENTIAL AND PROPRIETARY**

Figure 4-13  
Sheet 1

4.3 POWER/COOLING TROUBLESHOOTING GUIDE

The Troubleshooting Guide flowchart on this page can be used as an aid in locating a problem that is suspected of being in the power or cooling system. See Figure 4-13 Sheet 3 for power control module (PCM) controls and indicators.

REMARKS/NOTES

**WARNING**

HIGH CURRENT AND HIGH VOLTAGE SHOCK HAZARDS ARE PRESENT IN THE POWER SYSTEM.

1. NEVER CONNECT OR DISCONNECT POWER CABLES OR WIRING WHILE POWER IS ON.
2. WAIT AT LEAST FIVE MINUTES AFTER POWER IS OFF FOR THE CAPACITOR RIDE-THRU MODULE TO DISCHARGE BEFORE WORKING ON THE POWER SYSTEM.
3. OBSERVE AND OBEY ALL CAUTION AND WARNING SIGNS AND LABELS.

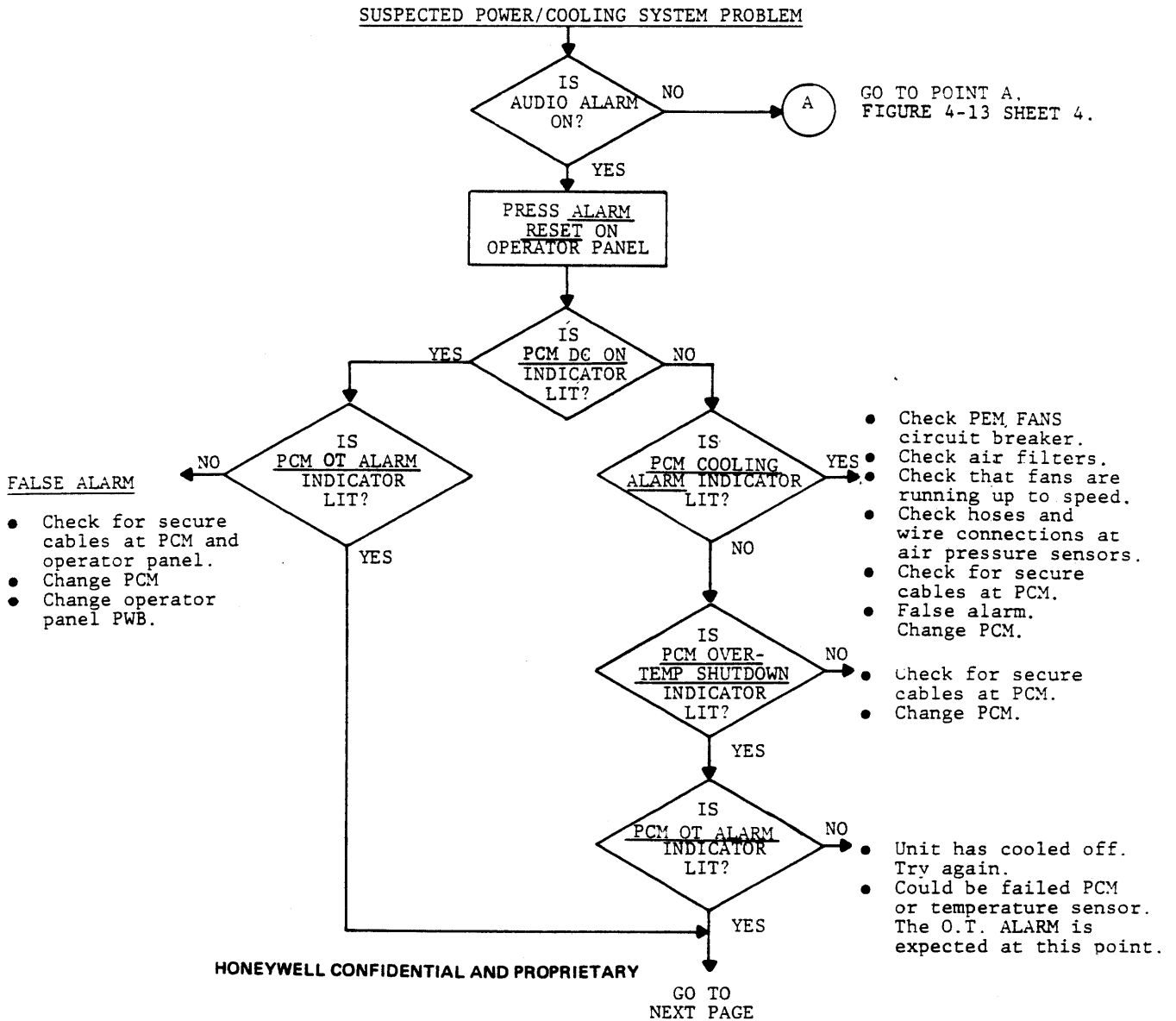

Figure 4-13 Sheet 2

POWER/COOLING TROUBLESHOOTING GUIDE - CONT'D.

4.3.1 REMARKS/NOTES

● GENERAL:

Package and return failed ORU to your Logistics Cluster with a completed repair form.

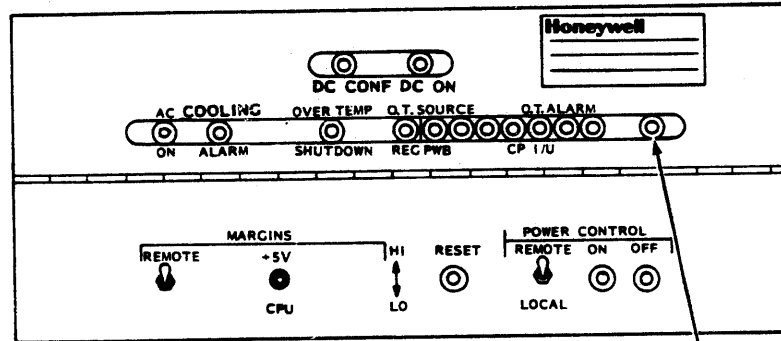

PCM Control Panel  
Figure 4-1A

CONTRCL REGULATOR CONFIDENCE  
INDICATOR (NOT LABELED)

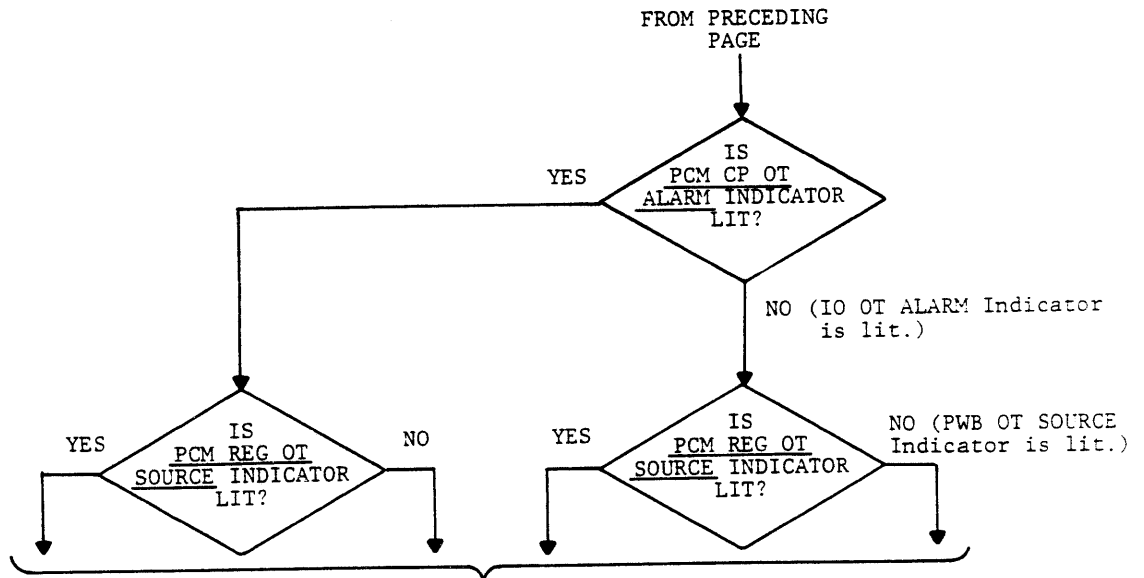

- Check for proper room temperature.
- Check for dirty air filters.
- Check for blocked air intake at front and rear of cabinet.
- Check for blocked air escape at top of cabinet.
- Check for overheated +5V power regulator. Replace if room temperature and air flow is normal.

HONEYWELL CONFIDENTIAL AND PROPRIETARY

Figure 4-13  
Sheet 3

POWER/COOLING TROUBLESHOOTING GUIDE - CONT'D.

4.3.1 REMARKS/NOTES (CONT'D.)

CONTROL REGULATOR CONFIDENCE INDICATOR (NOT LABELED)

PCM Control Panel Figure 4-1A

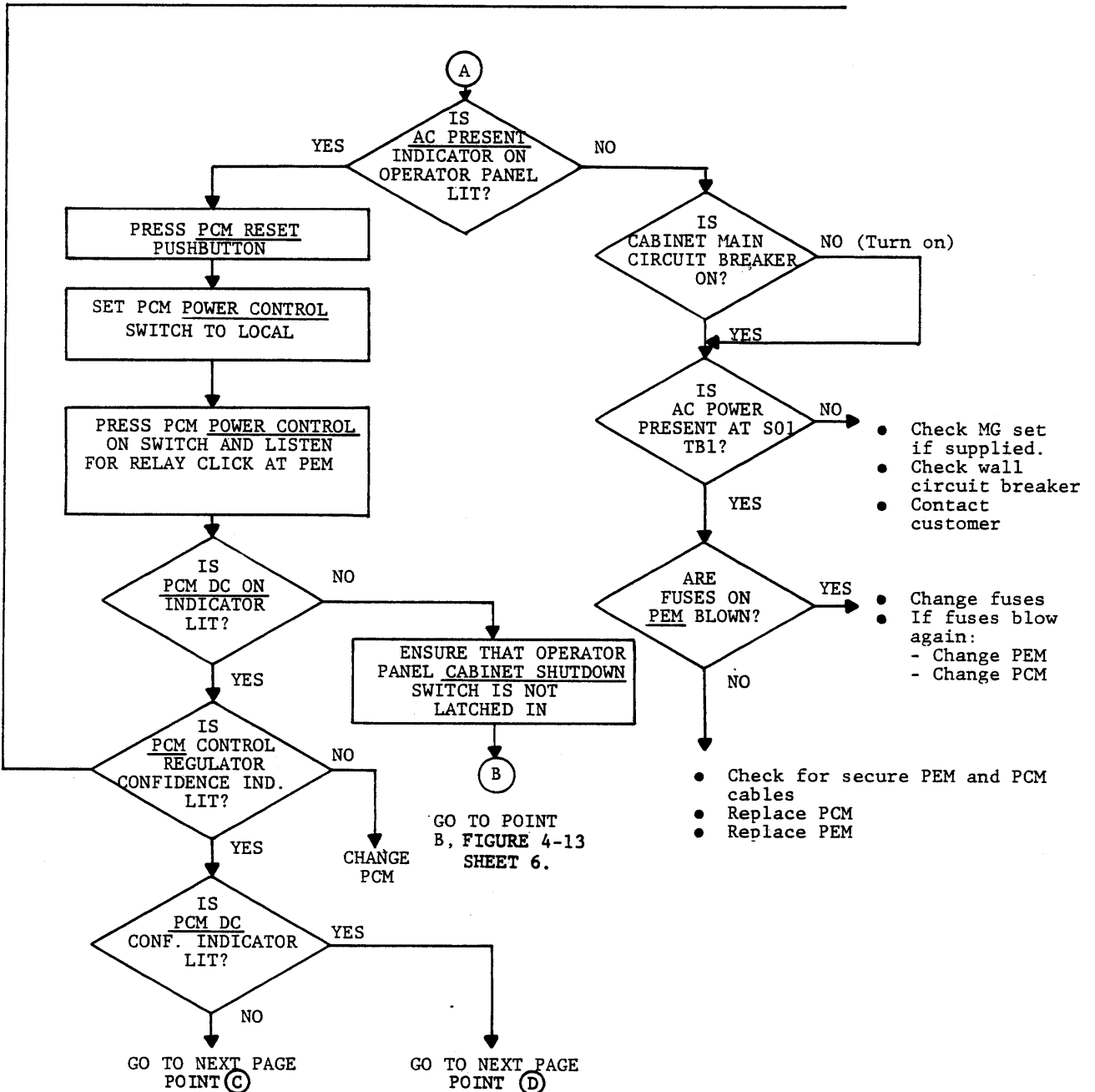
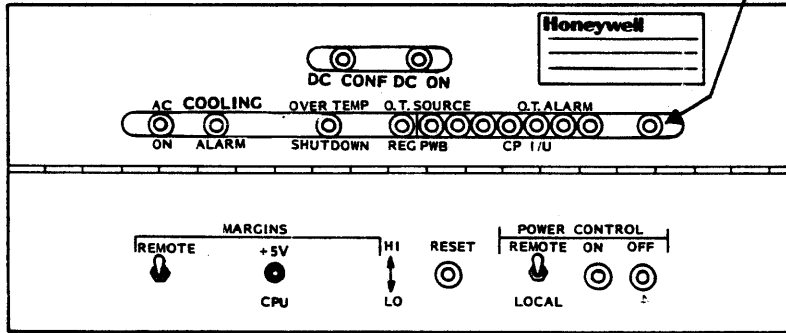

HONEYWELL CONFIDENTIAL AND PROPRIETARY

Figure 4-13 Sheet 4

POWER/COOLING TROUBLESHOOTING GUIDE - CONT'D.

4.3.1 REMARKS/NOTES (CONT'D.)

Before replacing any power regulator for a fault condition. Proceed as follows:

1. Turn overcurrent adjust potentiometer one or two turns CW and try to turn power on.
2. Turn output voltage adjust potentiometer one or two turns CCW and try to turn power on.
3. If either of the above corrects the fault, adjust regulator for proper operation.

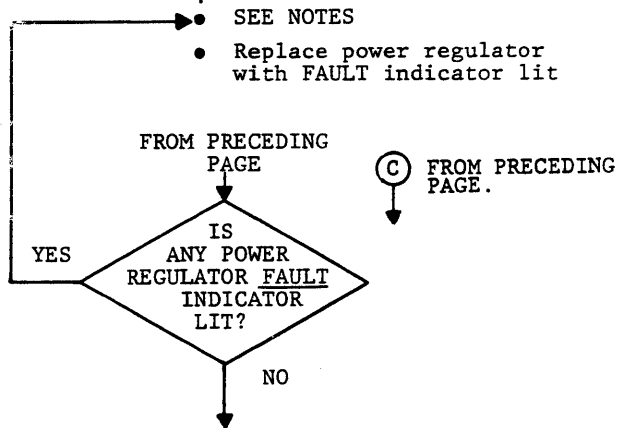

- Check each power regulator output
- Replace power regulator with no output if only one regulator is bad (SEE NOTES)
- Replace PCM if more than one regulator has no output

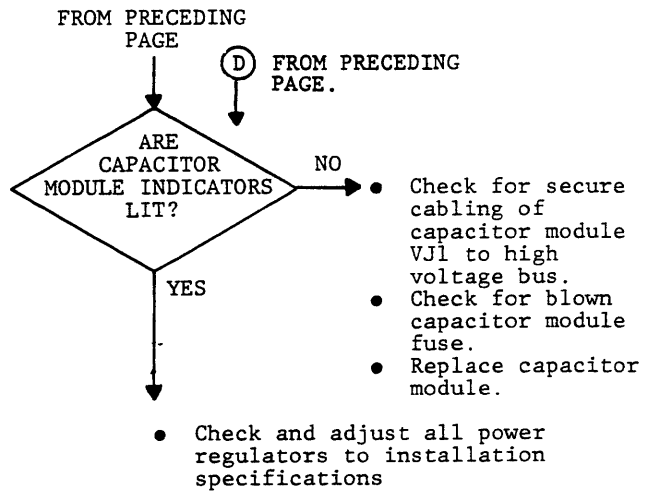

HONEYWELL CONFIDENTIAL AND PROPRIETARY

Figure 4-13  
Sheet 5

4.3.1 REMARKS/NOTES (CONT'D.)

**CAUTION**

BEFORE CHANGING SSM THE FOLLOWING STEPS MUST BE PERFORMED. OTHERWISE, THE NEW SSM WILL FAIL IMMEDIATELY WHEN POWER IS REAPPLIED.

1. Remove PEM
  - A. Disconnect one side of VR1 from L2 and check VR1 for short. Replace PEM if shorted.
  - B. Repeat above for VR2 and L3.
  - C. Check CR6 for short and replace PEM if shorted.
2. Reinstall PEM.
3. Remove capacitor module.

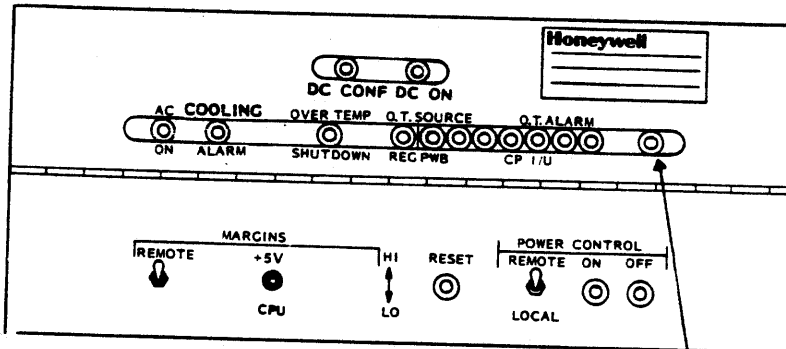

PCM Control Panel  
Figure 4-1A

FROM FIGURE 4-13 SHEET 4.

**CAUTION**

THE CAPACITOR MODULE WEIGHS ABOUT 66 POUNDS. CARE SHOULD BE TAKEN NOT TO DROP IT.

- Check CR1 for short and replace capacitor module if shorted.
4. Reinstall capacitor module.
  5. Change failed SSM.

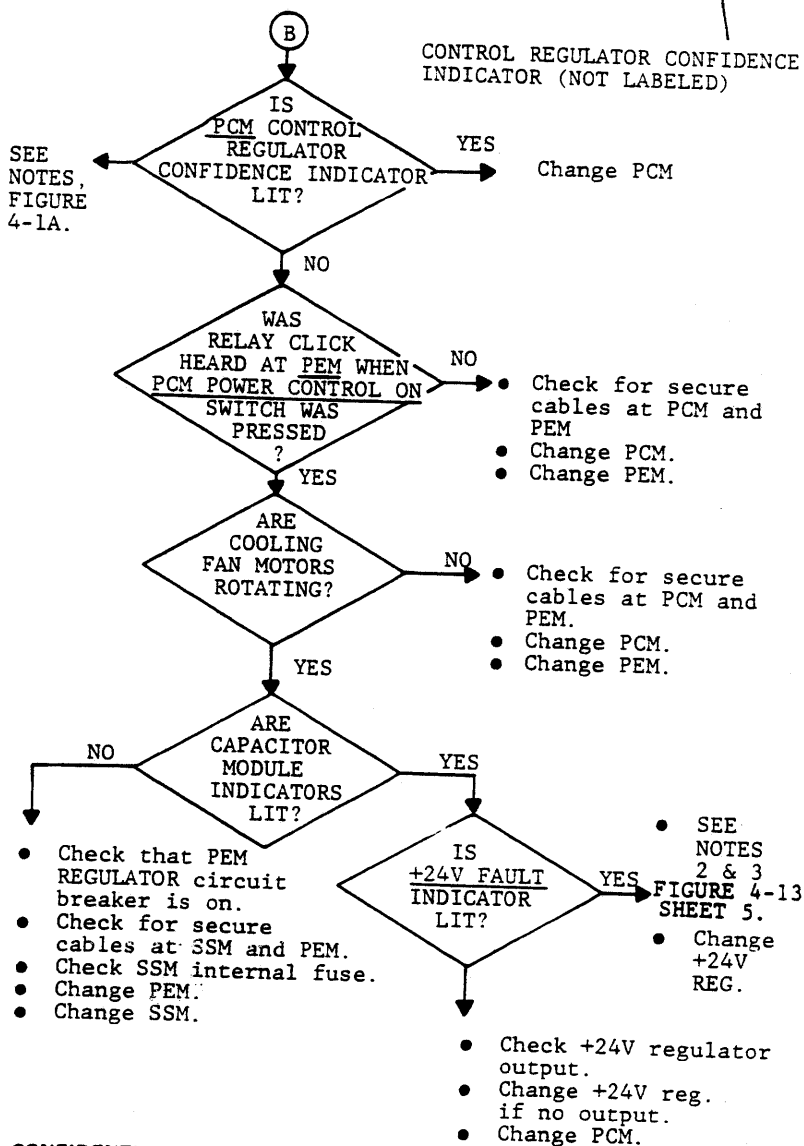

SEE NOTES - CAUTION



4.3.2 COOLING SYSTEM MAINTENANCE AIDS

4.3.2.1 AIR FLOW SENSOR SWITCH OPERATION

NOTE: THE AIR FLOW SENSOR SWITCH IS NORMALLY CLOSED. THE SWITCH OPENS WHEN THE BLOWER REACHES ITS NORMAL OPERATING SPEED ABOUT 4-8 SECONDS AFTER INITIAL STARTUP.

To check the operation of this switch proceed as follows:

NOTE: THE AIR FLOW SENSOR SWITCHES ARE LOCATED AT QXN1 and XZN1 ABOVE THE COOLING BLOWERS AT THE FRONT OF THE CABINET.

1. Remove switch cover.
2. Remove COMMON (top) wire.
3. Loosen NORMALLY OPEN (middle) screw.
4. Set WOM to scale RX1 and clip VOM to top and middle screws.
5. Turn blower on and allow a few seconds for blower to reach normal speed. If VOM reads a short, the switch is good; if VOM reads open, the switch is defective.

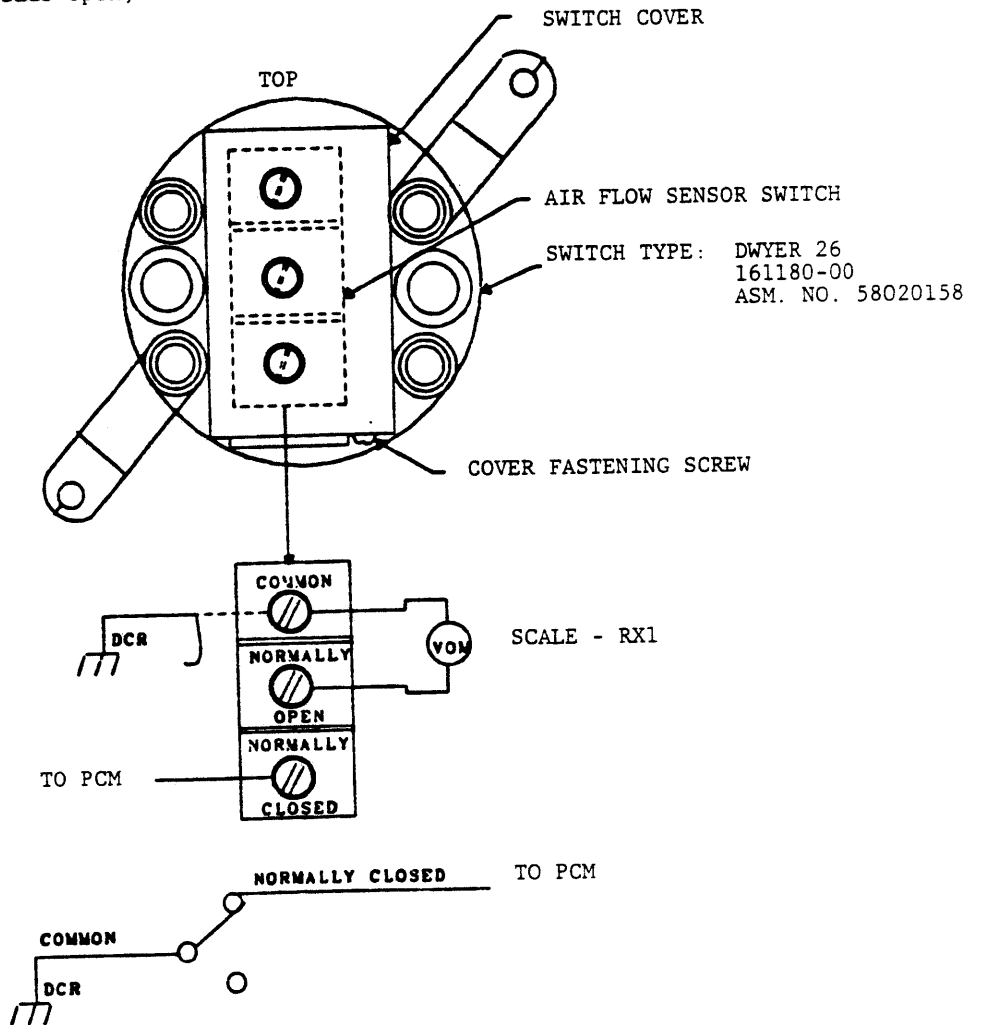

AIR FLOW SENSOR SWITCH

HONEYWELL CONFIDENTIAL AND PROPRIETARY

Figure 4-13  
Sheet 7