

TECHNICAL MANUAL

M 200 CARD READER

January 1972

 **DOCUMATION**
INCORPORATED

841 EAST NEW HAVEN AVENUE

MELBOURNE, FLORIDA 32901

(305) 725-5500

DOCUMATION, INCORPORATED

WARRANTY

All Documation, Incorporated products are warranted against defective materials and workmanship under normal use and service. The Documation, Incorporated obligation under this warranty is limited to the correction or replacement of any unit which proves defective in material or workmanship under normal use and service within one year after delivery, provided this unit is returned to the Documation, Incorporated shipping point with all transportation charges prepaid.

TECHNICAL MANUAL

M 200
CARD READER

January 1972

© DOCUMENTATION, INCORPORATED, 1971
No parts of this manual may be reproduced in whole or in part without written permission of Documentation, Incorporated.

**DOCUMENTATION**
INCORPORATED
841 EAST NEW HAVEN AVENUE
MELBOURNE, FLORIDA 32901

IMPORTANT NOTICE

THIS TECHNICAL MANUAL IS SUPPLIED
WITH DOCUMENTATION CARD READER SERIAL
NUMBER 7206123

THIS MANUAL SHOULD REMAIN WITH THAT
CARD READER.

TABLE OF CONTENTS

<u>Title</u>	<u>Page No.</u>
Introduction	1
General	1
Specifications	3
Operation	4
General	4
Initial Setup	4
Loading the Input Hopper	4
Unloading Stacker	6
Switches and Indicators	6
Rear Panel Switches	7
Operational Flow Chart	8
Theory of Operation	9
Card Track	9
Data Recovery	9
Oscillator/Four-Phase Clock Logic	14
Pick Control Logic	14
Sync Control Logic	17
Preset Counter Logic	17
Offset Count/Storage Register	21
Comparator Logic	21
Wide-Strobe Control Logic	23
Character Buffer/Output Logic	23
Column Counter Control Logic	26
Control Logic	26
Motion Check Logic	29
Lamp Drivers	29
Interface	30
General	30
Timing	30
Connectors	33
Signal Characteristics	35
Grounding	35

TABLE OF CONTENTS

Continued

<u>Title</u>	<u>Page No.</u>
Preventive Maintenance	36
General	36
Cleaning	36
Lubrication	38
Repair	39
General	39
Repair Procedures Table of Contents	39
Required Tools	39
Replacement of Hopper Empty Switch	41
Adjustment of Picker Sector Travel	41
Adjustment of Tension on Main Drive Motor Belt	41
Adjustment of Stacker Tray Spring	44
Stacker Shaft Support-Bearing Replacement	44
Replacement of Belt on Vacuum Pump Motor Assembly	46
Replacement of Main Drive Motor Belt	49
Replacement and Adjustment of Magnetic Pickup	52
Replacement of Solenoid	52
Replacement of Roller Bearings, Read Head or Light Station	55
To Replace Roller Assembly Bearings	57
To Replace Read Head	58
To Replace Light Station	58
Replacement of Picker	60
Replacement of Stacker Full Switch	61
Replacement of Stacker Photocell	61
Electrical Drawings	Appendix A
Parts List	Appendix B
Signal Mnemonics and Abbreviations	Appendix C

LIST OF ILLUSTRATIONS

<u>Figure No.</u>	<u>Title</u>	<u>Page No.</u>
1	Three-Quarter Front View	2
2	Three-Quarter Rear View	2
3	Switch Location	5
4	Operational Flow Chart	8
5	M Series Card Reader Logic Block Diagram	10
6	Timing Relationship for Standard Punched Card	12
7	Oscillator/Four-Phase Clock Logic Block Diagram	15
8	Pick Control Logic Block Diagram	16
9	Sync Control Logic Block and Timing Diagram (Sheet 1 of 2)	18
9	Sync Control Logic Block and Timing Diagram (Sheet 2 of 2)	19
10	Preset Counter Logic Block Diagram	20
11	Comparator Logic Block Diagram	22
12	Wide-Strobe Control Logic Block Diagram	24
13	Character Buffer Storage Logic Block Diagram	25
14	Column Counter Control Logic Block Diagram	27
15	Control Logic Block and Timing Diagram	28
16	Standard Interface Timing for M Series Readers	31
17	Circuit Characteristics	35
18	Removal of Fan Screen	37
19	Solenoid Lubrication	38
20	Three-Quarter Front View	42
21	Three-Quarter Rear View	42
22	Partial Front View, Cover Removed	43
23	Picker Sector Adjustment	43
24	Partial Front View, Stacker Spring	45
25	Rear View, Cover Removed	47
26	Rear View, Cover and Rear Connector Panel Removed	47
27	Front View, Main Wiring Connections	48
28	Front View, Main Mounting Plate Removal	48
29	Vacuum Pump Belt Adjustment	50
30	Bottom View, Main Mounting Plate	50
31	Timing Disc Air-gap Adjustment	51
32	Stacker Casting Removal and Bearing Replacement	53
33	Solenoid Replacement and Adjustment	54

LIST OF ILLUSTRATIONS

Continued

<u>Figure No.</u>	<u>Title</u>	<u>Page No.</u>
34	Top View Casting Assemblies	56
35	Bottom View Main Drive Motor Assembly	56
36	Top View Stacker Casting Assembly	59
37	Stacker Panel Removal	59
38	Stacker Full Switch Replacement	62
39	Main Frame Component Location	63

INTRODUCTION

GENERAL

This manual provides operational, interface and maintenance information for the M 200 Punched Card Reader manufactured by Documation Incorporated, 841 East New Haven Avenue, Melbourne, Florida 32901. The manual is sectionalized to cover operational instructions, theory of operation, interface details, preventive maintenance, and repair. The appendix includes electrical schematics and wiring details.

The M 200 Card Reader shown in figures 1 and 2, is designed to read standard EIA 12-row, 80 column punched cards. The hopper capacity is adequate to hold approximately 550 cards of .007" thickness. These are separated from the stack sequentially and moved past a phototransistor read station where the data is recognized in a serial, column-by-column manner. The cards are then stacked into the output hopper in the same order as they were originally put into the reader. The reading cycle is externally controlled for single card selection or continuous run. In the continuous mode, the reader will read 300 cards per minute.

The M Series card readers are specifically designed for continuous duty operation in adverse operational environments. The chassis is of heavy duty construction and all components have been chosen to provide for rugged, reliable performance. The vacuum-type picker has a remarkable tolerance to mutilated, warped, and edge-damaged cards. The short card track and gentle acceleration forces of the card handling mechanism yield insignificant wear so that card decks routinely last in excess of 1000 passes.

The information contained in this manual is accurate and complete as of the date of publication. Documation will continue to improve both its products and the effectiveness of its documentation. Comments and suggestions as to how this manual may be improved are solicited. Address comments to:

Engineering Writer
Documation, Incorporated
841 East New Haven Avenue
Melbourne, Florida 32901
(305) 724-1111

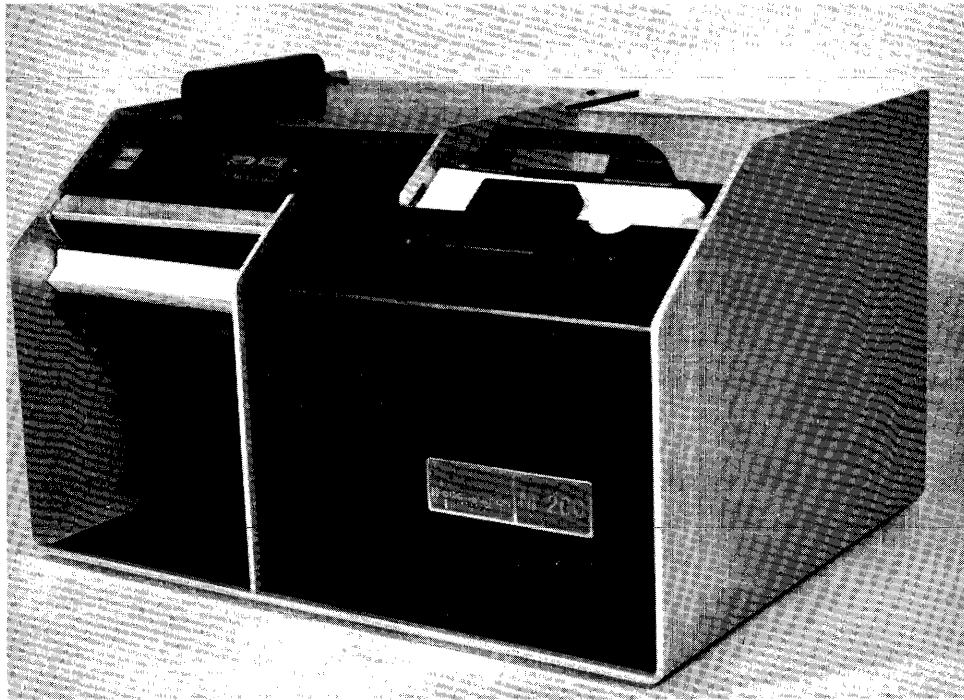

Figure 1. Three-Quarter Front View

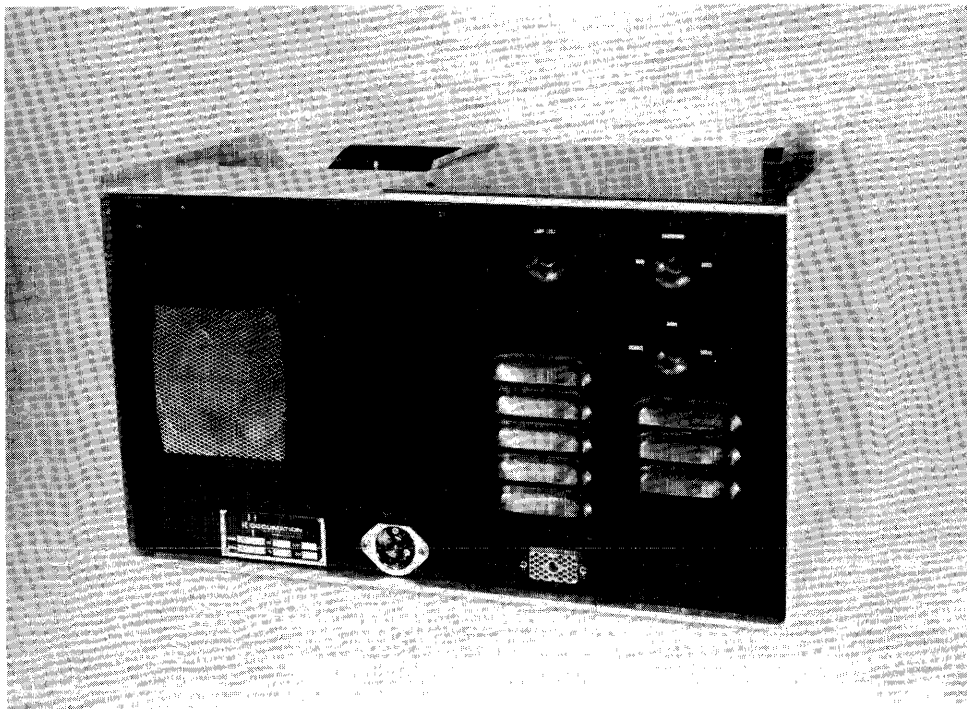

Figure 2. Three-Quarter Rear View

M 200 SUMMARY SPECIFICATIONS

Reading Speed: 300 cards per minute maximum in continuous run.
Single Card Cycle: 200 milliseconds.

Card Type: Standard 80 column EIA card.

Control: Demand feed, one card-at-a-time under external program control. Reader will continuous run as long as the Pick Command remains TRUE.

Hopper Size: 4.0 inches (approximately 550 cards of 7 mill thickness).

Stacker Size: 4.0 inches (approximately 550 cards of 7 mill thickness).

Power Requirements:

Voltage: 115 VAC \pm 15V, single phase, @ 60 hz (standard model)
230 VAC \pm 30V, single phase, @ 50 hz (export model)

Power: 950 VA starting load for 3 sec
400 VA running load

Size:

Height: 11 inches 27.9 cm

Width: 19 $\frac{1}{4}$ inches 48.9 cm

Depth: 14 inches 35.5 cm

Weight: 60 lbs. 27.3 kg

OPERATION

GENERAL

The following paragraphs provide description and instructions for normal operation of the M Series Card Readers. All operator controls and indicators are described with turn-on/shut-down instructions included. Refer to figure 3 for the location of switches and indicators mentioned in the following description.

INITIAL SET-UP

1. Upon receipt of a new reader from the manufacturer, the two red 8-32 screws in the bottom plate must be removed. These lock the blower motor plate for shipment to prevent damage to the motor plate vibration isolators. If the reader is to be reshipped, these screws should be retained and reinserted prior to packing.
2. Plug in the AC power cord. Notice that this is a clockwise twist-lock connector.
3. Set the MODE switch (rear panel) in LOCAL.
4. Set the SHUTDOWN switch (rear panel) in AUTO.
5. Switch the CIRCUIT BREAKER (power switch) to energize the reader (blower will not come on at this time).
6. Press the LAMP TEST switch and observe that all front panel indicators illuminate.
7. Load a deck of cards into the input hopper.
8. Press the RESET switch. The blower should come on and after a short delay (approx. 3 seconds), the cards should be picked and stacked. When the input hopper is empty, the blower should shutdown and the HOPPER CHECK light illuminate.
9. This completes the initial off-line operational test.

LOADING THE INPUT HOPPER

Loading the input hopper with punched cards to be read is performed as follows:

1. Pull the hopper follower back with one hand and load the card deck into the hopper area; the first card to be read must be placed at the front with the "9" edge down, column 1 to the left. Continue placing cards into the input hopper until it is loosely filled (approximately 550 cards).

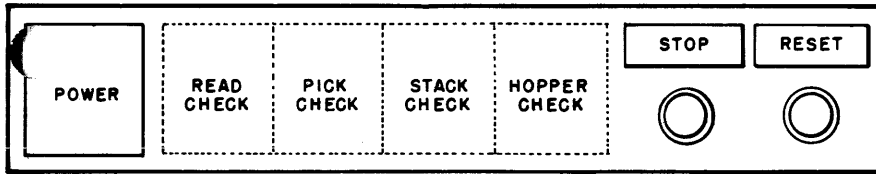

FRONT CONTROL PANEL

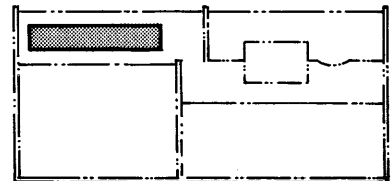

AC POWER SWITCH

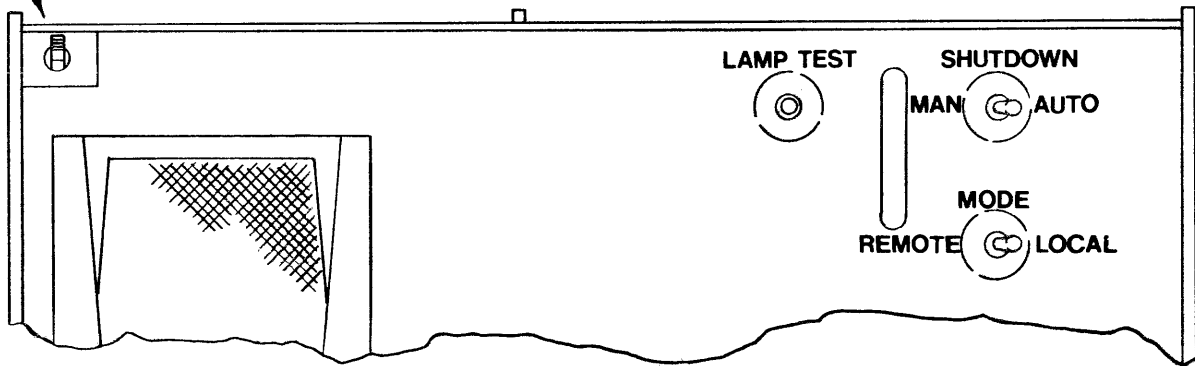

REAR PANEL

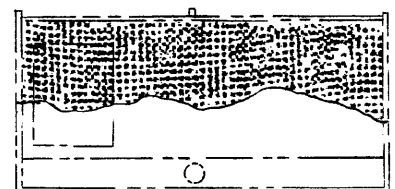

Figure 3. Switch Location

CAUTION

DO NOT PACK THE INPUT HOPPER SO FULL
THAT THE RIFFLE ACTION IS INHIBITED

2. The hopper may be loaded while cards are being read if the operator is careful to keep tension on the front portion of the deck while loading additional cards at the rear. This is best done with the input hopper approximately $\frac{1}{2}$ to $\frac{1}{3}$ full. Use just enough pressure to maintain the riffle action.

3. Unloading the input hopper is the reverse of the loading procedure. Normally all cards are processed through the reader; however, if it is necessary to unload the hopper, push the follower down and remove the card deck. If the cards are arranged in a particular order, exercise care in repacking them in their storage container so that the order is maintained.

UNLOADING STACKER

To unload the stacker, perform the following steps:

1. Pull stacker follower back with one hand and remove the front or rear portion of the card deck from the stacker area, being careful that deck order is maintained.

2. The stacker may be unloaded while cards are being read.

SWITCHES AND INDICATORS

POWER (toggle circuit breaker and indicator)

All power to the card reader is controlled by this circuit breaker. Since the indicator is supplied by the +5V power supply, it is illuminated only when power has been applied to the entire AC distribution system. Toggling the switch (indicator is illuminated) in down position removes the power from the card reader.

STOP (momentary-action pushbutton/indicator switch)

Actuation of the STOP switch immediately overrides the PICK COMMAND and lowers the READY line. The card reader will stop operation after the card currently in the track is read completely; power is not removed from the reader by this action. The red STOP indicator is illuminated as soon as the switch is depressed.

RESET (momentary-action pushbutton/indicator switch)

Actuation of the RESET switch clears all error flip-flops and initializes all counters. The reset action is initiated by the return stroke of the RESET switch. The green RESET indicator is the READY signal that also appears at the output connector. The card reader is then ready to accept a PICK COMMAND.

READ CHECK (indicator)

The READ CHECK alarm indicator denotes that the card just read may be torn on the leading or trailing edges or have punches in the 0 or 81st columns. The READ CHECK will cause the reader to stop. If it occurs on all cards, it is an indication of a fault in the read electronics.

STACK CHECK (indicator)

The STACK CHECK alarm indicator denotes that the previous card was not fully seated in the output hopper. Check the card track to make sure it is clear and check the stacker for a badly mutilated card.

PICK CHECK (indicator)

The PICK CHECK alarm indicator denotes that a card has failed to reach the read station after a PICK COMMAND has been received. Inspect the cards in the input hopper for excessive leading edge damage, torn webs, or cards stapled together. If so, remove the staple or straighten the card and reinsert.

If no apparent card damage is present, check for excessive card deck warpage (in excess of 1") and/or ink glaze buildup on the picker face. Clean the picker face with solvent.

HOPPER CHECK (indicator)

The HOPPER CHECK alarm indicator denotes that either the input hopper is empty or the stack hopper is full. This is a normal operational occurrence.

REAR PANEL SWITCHES

LAMP TEST (pushbutton switch)

Depressing the LAMP TEST switch illuminates all front-panel indicators to determine if an indicator lamp is inoperative.

MODE (toggle switch)

When placed in the LOCAL position, this switch disables the PICK COMMAND input to the card reader and allows the operator to run the reader off-line by depressing the RESET pushbutton switch on the front panel. When placed in the REMOTE position, this switch enables the PICK COMMAND input to the card reader, which places the reader on-line for normal remote control operation. Data and other output signals are present at all times.

SHUTDOWN (toggle switch)

When placed in the MANUAL position, this switch energizes the blower for continuous operation whether or not cards are in the input hopper. When placed in the AUTO position, this switch provides an automatic shutdown of the blower

when the input hopper is emptied. The blower will automatically restart when cards are placed in the hopper and the RESET switch is depressed. Expect a delay of approximately 3 seconds for the blower to run up.

OPERATIONAL FLOW CHART

Figure 4 shows a flow chart of the sequence of events which may be encountered in operating the reader. If trouble is experienced, refer to this check list before calling for maintenance.

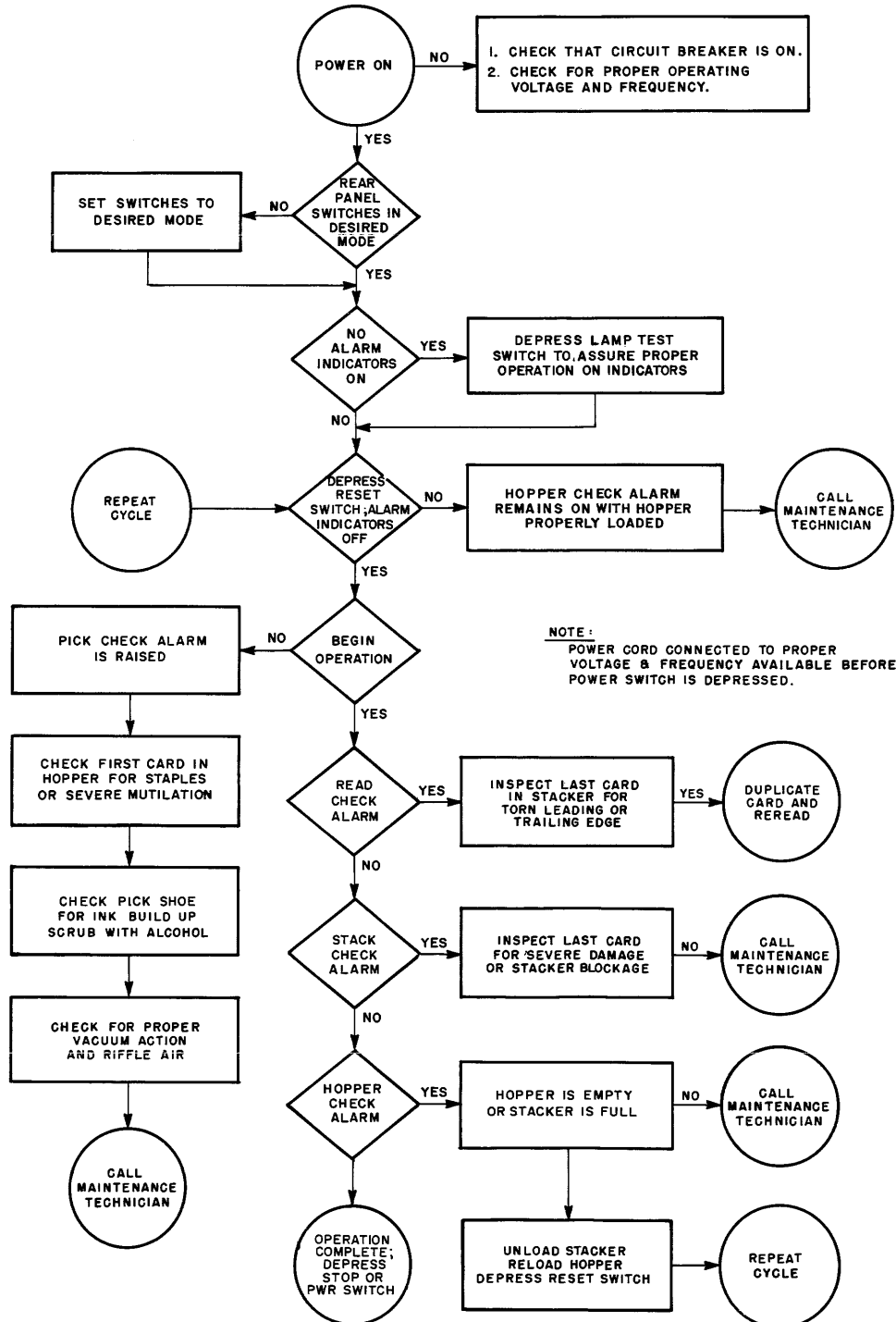

Figure 4. Operational Flow Chart

THEORY OF OPERATION

CARD TRACK

The Documentation card reader line is unique in several respects, in that card wear is insignificant and a card jam is virtually an impossibility. The card track is designed around a patented vacuum picker which works in conjunction with riffle air in the input hopper to produce a card reader which is very tolerant to damaged cards. This tolerance extends to cards which have been badly worn, edge nicked, warped, bent, folded or otherwise damaged as a result of rough handling.

The riffle air acts on the first half inch of cards in the input hopper so that they stand apart, individually "air cushioned" from the rest of the card deck and each other. This prevents the cards from sticking together in case of static electricity, hole locking, or torn webs. Should the cards have been subjected to high humidity conditions prior to being loaded into the card reader, the riffle air also minimizes the effect of swelling or frictional increases between the cards.

The picker mechanism utilizes a strong vacuum to grasp the bottom card, and upon command, draw it away from the bottom of the stack. The card is smoothly accelerated through the wide throat into the constant speed drive rollers. The design of the vacuum picker and its associated throat block prevent the unit from double picking so well that cards which are even stapled together will not enter the card track. Should cards which are stapled or taped together be inadvertently put in the input hopper, the card reader will stop, indicating a PICK CHECK. The operator can remove the staples, separate the cards, re-enter them in their proper position in the deck and resume reading.

The card track itself is very short so that at no time is more than one card in motion. The combination of damaged card tolerance, gentle card treatment and short card track have produced a card reader which is virtually jam proof. Card life has proven to be in excess of 1000 passes.

DATA RECOVERY

The logic block diagram for the M Series card reader is shown in figure 5. The description that follows applies to all Documentation M Series punched card readers since the reliable recovery of data from cards passing down the card track is accomplished in the same manner regardless of track velocity.

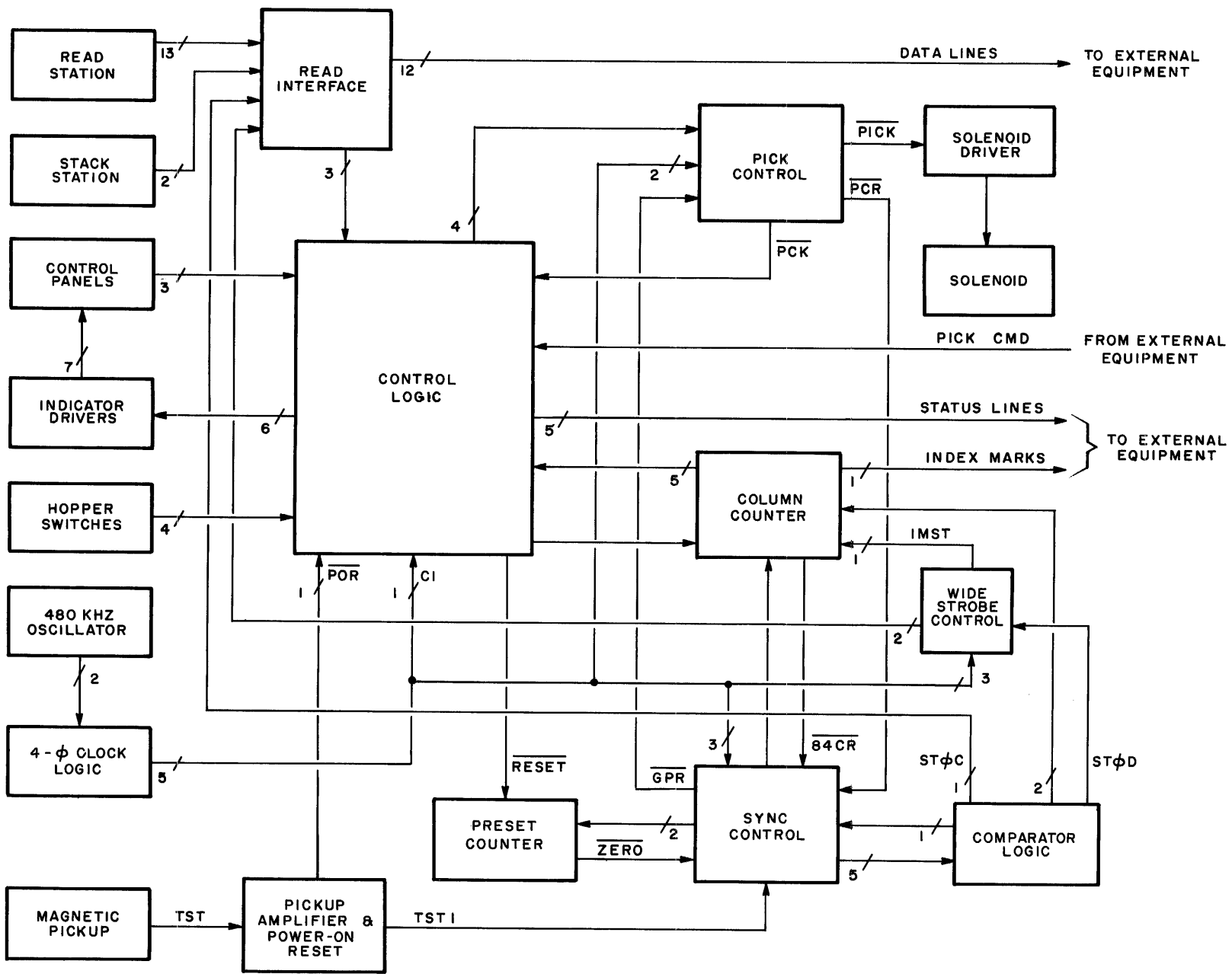

Figure 5. M Series Card Reader Logic Block Diagram

The heart of the card reader electronics is the control logic and sync control, where the internal logic timing and the movement of the card past the read station is synchronized to enable accurate sequential interpretation of the data on the card. Primary logic timing is established by the 480-KHz crystal oscillator and the associated four-phase clock logic, whose outputs are used to shift, store, and control other timing operations. Card movement speed is established by the hysteresis synchronous drive motor, belts and steel drive rollers. A timing disk consisting of a ferrous notched wheel is mounted on the drive roller shaft. Synchronization input to the logic is derived from the magnetic reluctance pickup associated with this timing disk. Sufficient resolution is provided such that two signals are produced by the pickup for each card data column as it is moved through the card track at the track speed of the particular M Series reader being used.

When a PICK COMMAND is received from the external program control, card processing will be started provided no alarm conditions exist with the card reader powered up. The Pick Control logic then produces a PICK signal to the Solenoid Driver, a PCLK signal to the control logic, and a pick-command reset (PCR) to the sync control. These actions initialize the various control circuits and energize the solenoid to pick a punched card from the input hopper. If a card does not reach the read station, the PICK CHECK alarm is raised.

The read station and stack station utilize phototransistor sensor arrays to both read the card hole pattern and to monitor card movement. When a card is picked and moved into the card track, the leading edge is detected by the first phototransistor in the read station to go dark. This produces a Good Pick Reset (GPR). As the card continues to move past the read station, the various control circuits are synchronized with the card movement to enable interpretation of the column data contained in the card hole patterns and to output this data at the same timing point for each of the 80 columns.

Since GPR is generated by the leading edge of the card, its occurrence is also utilized to start the synchronization process necessary for the precise generation of the data column strobes. At GPR, the Preset Counter is enabled to produce an interval equivalent to the time it takes the card to move 0.049 inches. || The value of this preset interval is different for each reader model and is hard-wired into the counter. || Its value establishes the time that should elapse from the detection of the leading edge of the card to the occurrence of the first possible data column 0' (see figure 6). The first two data holes

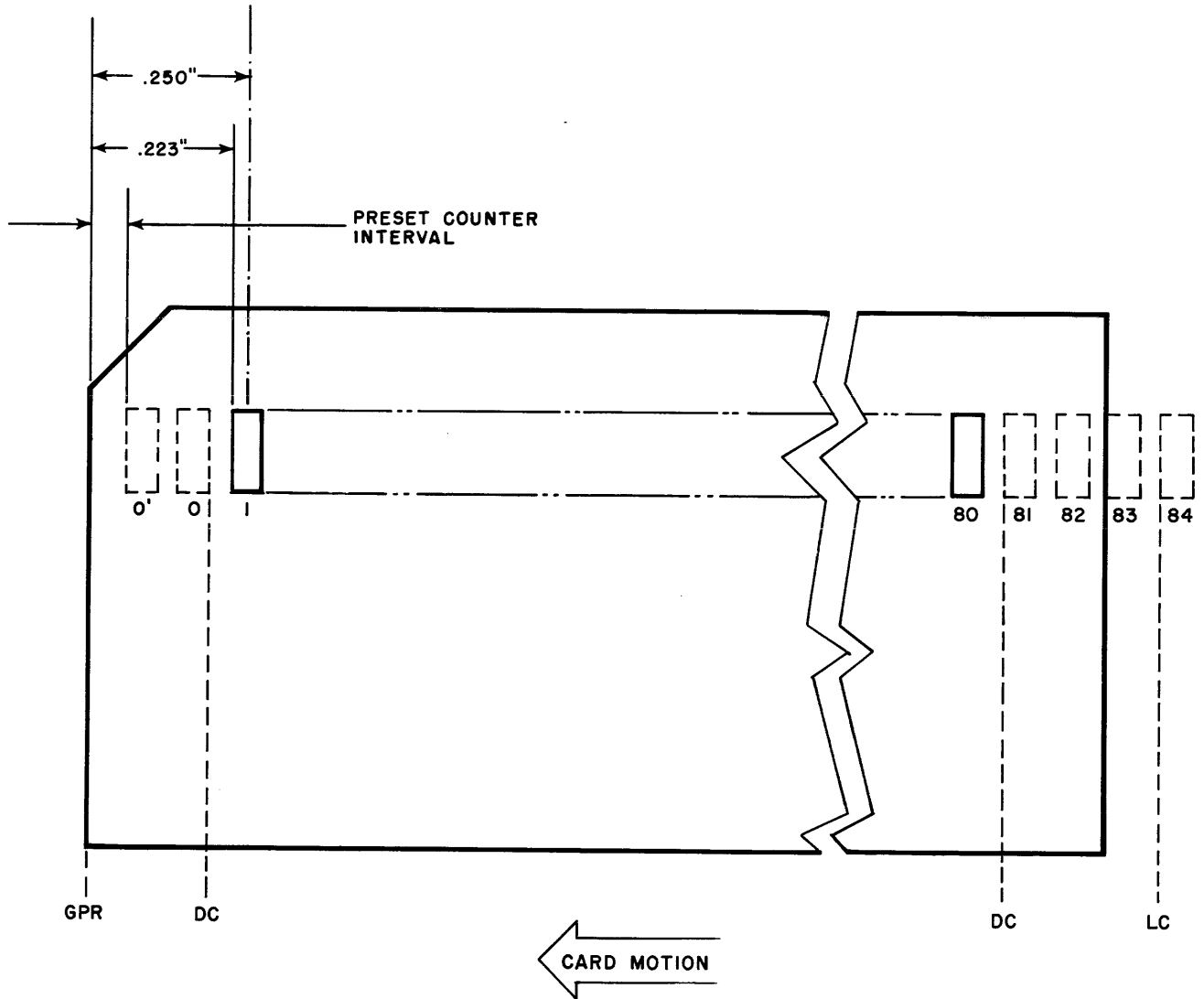

NOTES :

- (1) DASHED LINES INDICATE PSEUDO HOLES IN CARD.
- (2) DC = DARK CHECK
LC = LIGHT CHECK
GPR = GOOD PICK RESET
- (3) HOLE SIZE EXAGGERATED FOR EXPLANATION.

Figure 6. Timing Relationship for Standard Punched Card

are actually pseudo-columns, since by EIA standard, no data appears in the first 0.223 inches of the card.

When the Preset Counter ZERO signal is produced, indicating the end of the preset period and the start of card data columns, the Offset Count is set to synchronize the card reader logic to the signals from the magnetic pickup. This offset is the value of the count accrued during the time from the beginning of pseudo-column 0' to the second occurrence of a signal from the timing disk (TST). Refer to page 21, paragraph OFFSET COUNT/STORAGE REGISTER for the detailed discussion. Once established, this relationship will remain constant for the rest of the data columns on that card. Since two TST pulses are provided for each data column, every second TST pulse starts the Offset Counter in the comparator which counts until it matches the value of the Offset Storage. Thus, the offset value is determined and stored at the beginning of each card, then utilized to establish the same data-read point for each of the 80 data columns on that card. Since each offset comparison is derived from the timing disk signal (TST), the strobes are hence precisely locked to the progress of the card past the read station. This synchronization is accomplished within the comparator logic, which produces the strobe signals. Figure 6 shows the basic punched card with its relation to GPR, pseudo holes, and data column holes.

The STØC signals from the comparator logic are counted by the Column Counter to produce the character-count strobes, index-marker strobes, and light/dark-check strobes required for each card. The STØD is used to start the Wide-Strobe Control logic, which establishes the timing point for the index marker strobe (the spacing of the index markers will vary according to the speed of the model being used); the Wide-Strobe Control logic also produces the column data enables that are used to store data for each column into the storage registers in the interface logic. The index marks and the twelve data lines are then made available to the external equipment via the output/interface connector (J2).

This summarizes the function accomplished by the logic circuits supplied with each card reader. The following sections describe each operational block in more detail. The reader should familiarize himself with the various signal mnemonics used in the text description since it will aid in interpreting the detailed logic schematics contained in the appendix.

OSCILLATOR/FOUR-PHASE CLOCK LOGIC

A general block diagram and timing diagram of the Oscillator/Four-Phase Clock logic is shown in figure 7. The oscillator is a 480-KHz, crystal-controlled clock assembly manufactured by Motorola with TTL compatible outputs. The two-stage control register divides the oscillator output by four and provides phasing to the control gates. These gates are then strobed by the inverted clock signal to produce the four phases of output clock for internal timing as one-microsecond wide signals, shifted by approximately one microsecond from each other. The C1 clock is the inverted output of one flip-flop in the two-stage control register and is a symmetrical squarewave approximately 8.33 microseconds wide (120 KHz frequency).

PICK CONTROL LOGIC (Sync Card)

The function of the Pick Control logic (figure 8) is to:

1. Receive the clocked pick command ($\overline{\text{PCLK}}$) from the control logic
2. Generate the solenoid drive pulse ($\overline{\text{PICK}}$)
3. Wait out the interval while the card leading edge is accelerated to the read station (between 14 to 27 ms)
4. If the leading edge has not arrived in 50 ms, generate another solenoid drive pulse ($\overline{\text{PICK}}$)
5. Repeat the pick attempt six times and if the leading edge has not appeared, generate a pick fail alarm ($\overline{\text{PSET}}$).

When the external program PICK COMMAND is received after power-on reset (POR) has occurred and if no alarm condition exists (READY line raised), the control logic initiates the pick sequence by gating the C1 clock to produce $\overline{\text{PCLK}}$. The $\overline{\text{PCLK}}$ signal is counted by two decade counter stages and a six-stage binary counter in the Pick Control logic. Decode gates are provided to set and later reset a solenoid control FF generating a timed solenoid drive pulse ($\overline{\text{PICK}}$), which energizes the pick solenoid to move the bottom punched card into the card track.

If the card is not picked, the six-stage binary counter continues to receive the $\overline{\text{PCLK}}$ signal and after approximately 50 ms rolls over to begin another up-count. This recycles the solenoid control FF through its set/reset sequence and produces another pick attempt. Each solenoid drive signal is counted by a three stage binary counter and after six complete pick attempts, an alarm signal ($\overline{\text{PSET}}$) is generated to disable the pick control and indicate a PICK CHECK.

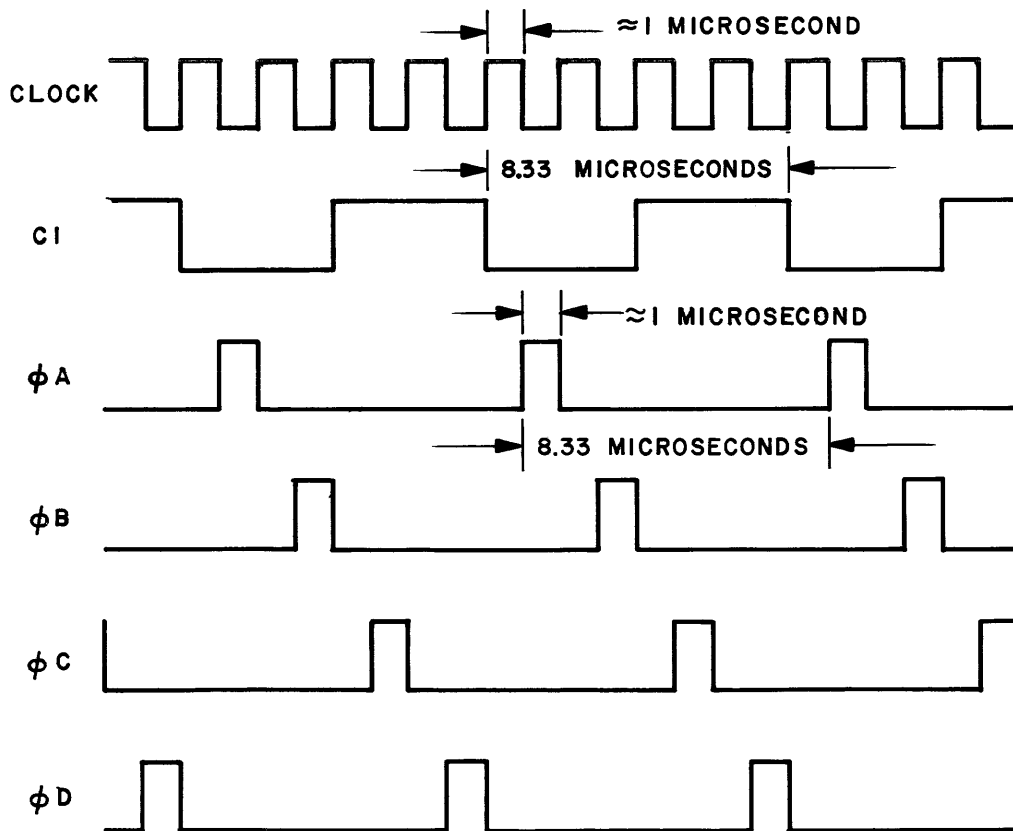
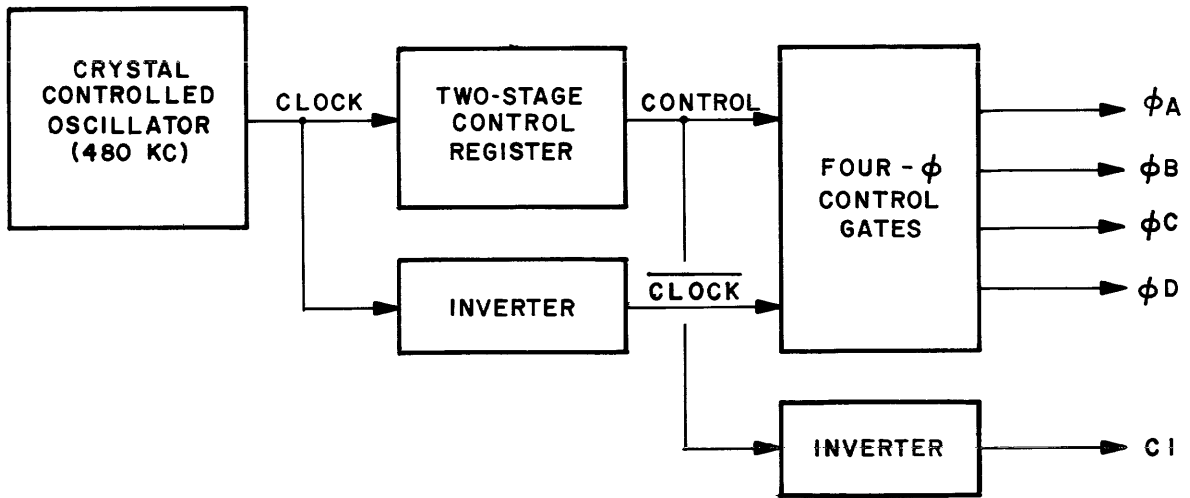
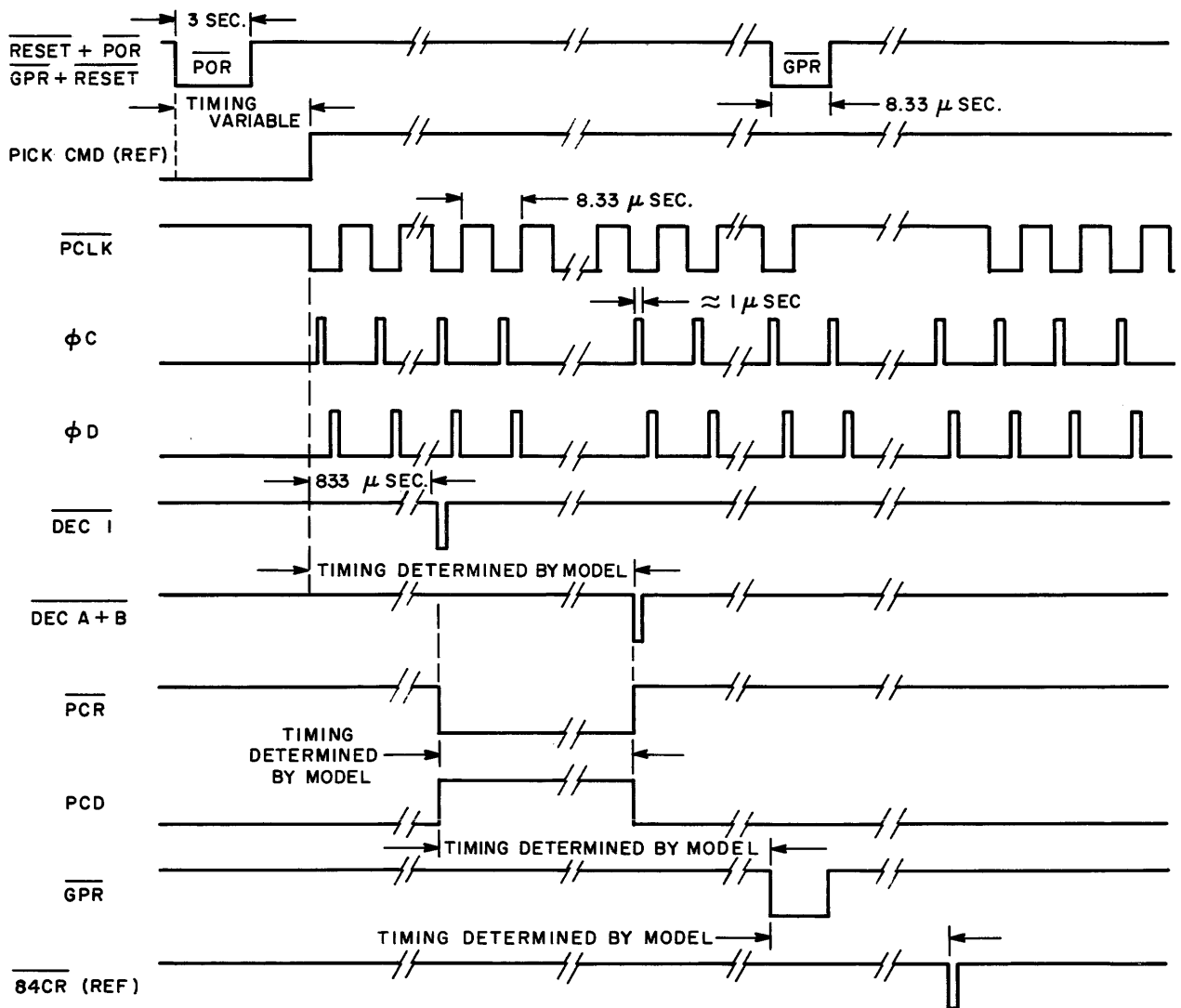
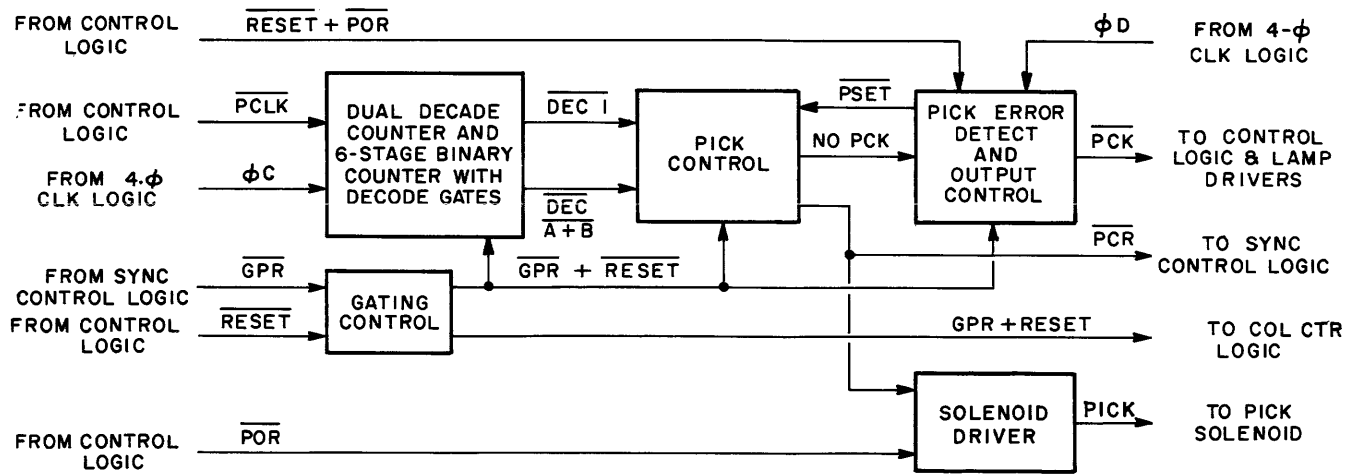

Figure 7. Oscillator/Four-Phase Clock Logic Block Diagram



NOTE: TIMING NOT SHOWN TO SCALE.

Figure 8. Pick Control Logic Block Diagram

If a card is picked at any time before the end of the sixth attempt, a Good Pick Reset (GPR) is produced to reset the Pick Control logic counters until the end of the read cycle for the picked card. The GPR pulse is generated when the leading edge of a card first reaches the read station. The end of the read cycle is defined as the 84th pseudo-column ($\overline{84CR}$) passing the read station (see figure 6). The $\overline{84CR}$ signal, generated by the Column Counter logic, enables the \overline{PCLK} to be started again if the external program PICK COMMAND is still present and the READY line is still raised. The above cycle repeats until all cards in the input hopper have been processed or until an error condition occurs.

SYNC CONTROL LOGIC

The Sync Control logic (figure 9) provides data readout synchronization from the timing disk. The timing disk is mounted on the same shaft as the first capstan roller. This capstan roller engages the card as it is released by the picker and thereafter determines the speed at which the card will be moved through the card track. The asynchronous card pick sequence causes the card to arrive at the read station at an arbitrary time in relation to the timing disk. The edge of the ferrous alloy timing disk is provided with gear-type serrations such that two flux reversals occur for each column of data on the card moving down the card track. These are sensed by the magnetic pickup and its associated amplifier to produce two TST1 signals for each column of data.

From figure 6 it can be seen that the first one-quarter inch of a punched card, (which contains no data per EIA standard) could have two data columns punched into it. The M Series reader logic assumes the presence of these columns as if they do exist and they are called column 0' (first pseudo-column occurring after the leading edge) and column 0 (second pseudo-column).

PRESET COUNTER LOGIC

The TST1 signals produced by the timing disk pickup amplifier are gated with the internal logic clock to produce the TST2 signals as positive-going, 8.33-microsecond output pulses that are phased to $\emptyset C$ of the four-phase clock. When GPR occurs, the \overline{PRCLK} signal is started by the store and offset control logic circuits. This clock signal is used to drive the Preset Counter logic. See figure 10. The Preset Counter is used to produce the delay necessary while the card moves the distance from the leading edge of the card to the beginning of pseudo-column 0'. This value is different for each track velocity used in the various M Series card readers. The occurrence of the GPR signal is used

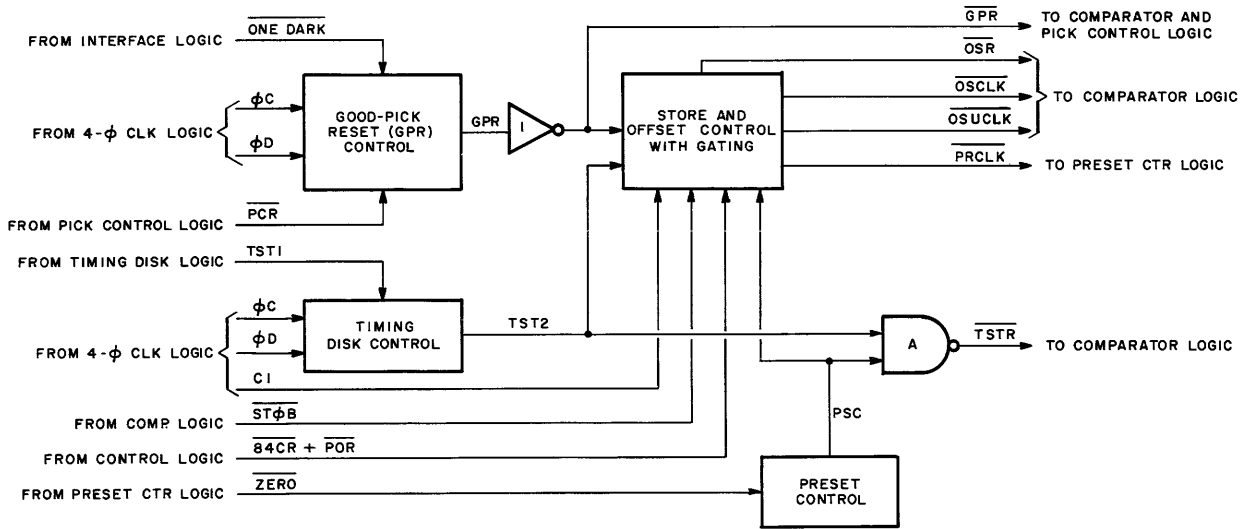

NOTES:

- (1) FOLLOWING TIMING NOT SHOWN TO SCALE.
- (2) TIME SCALE OF SECOND GROUP NOT SAME AS FIRST GROUP.

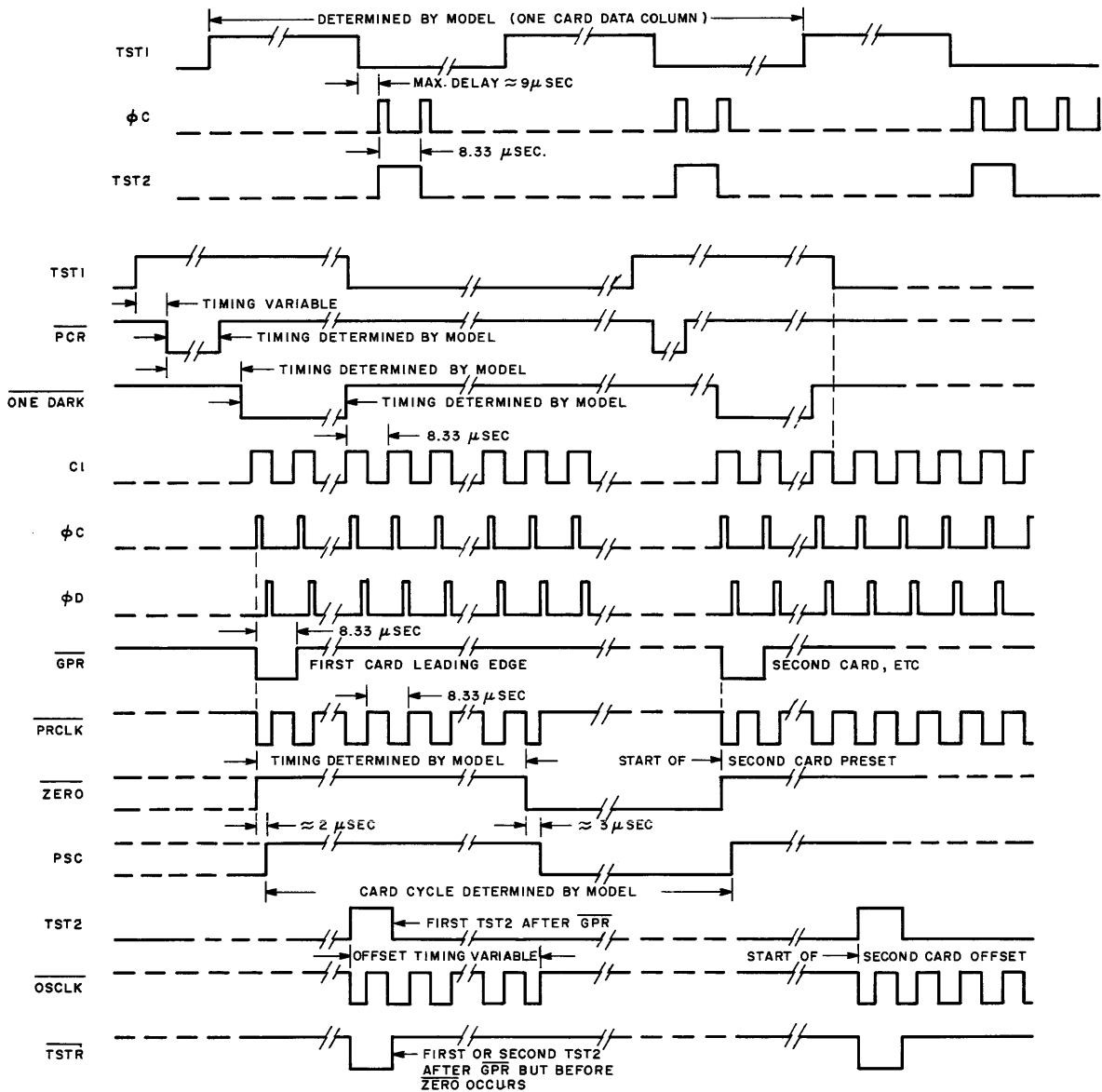

Figure 9. Sync Control Logic Block and Timing Diagram (Sheet 1 of 2).

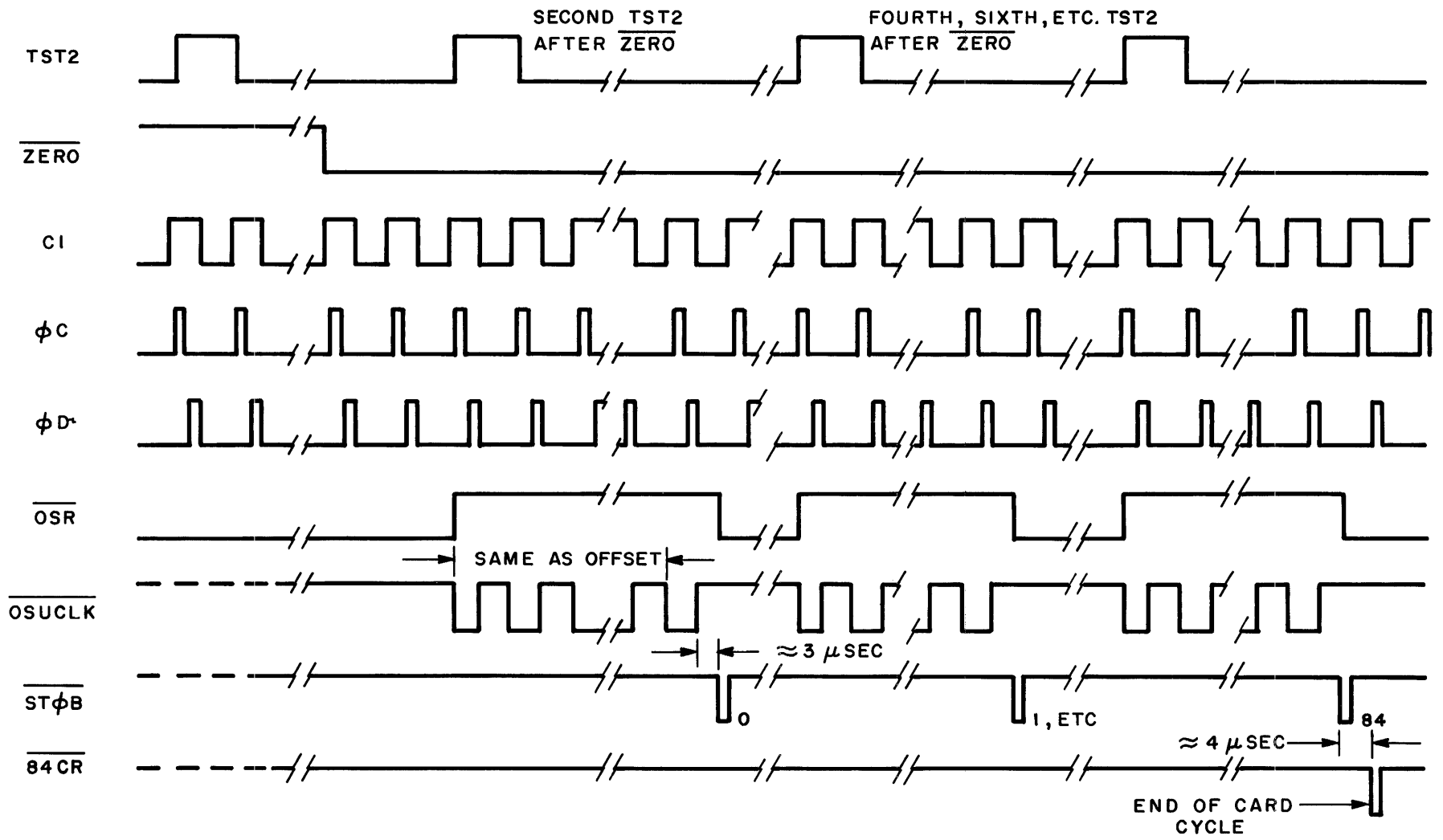
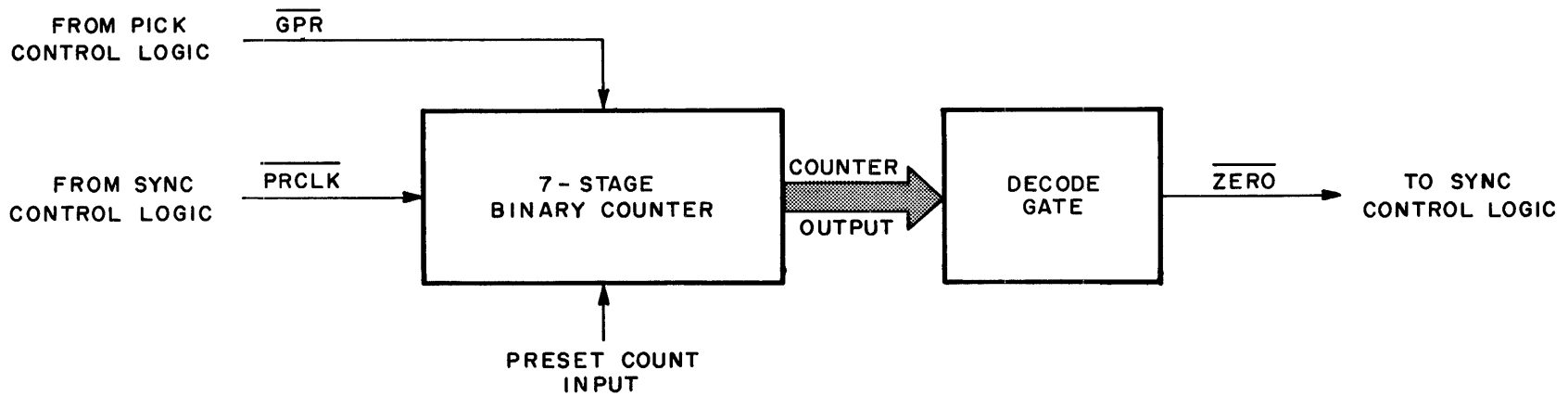

Figure 9. Sync Control Logic Block and Timing Diagram
(Sheet 2 of 2)



NOTE:
TIMING NOT SHOWN TO SCALE

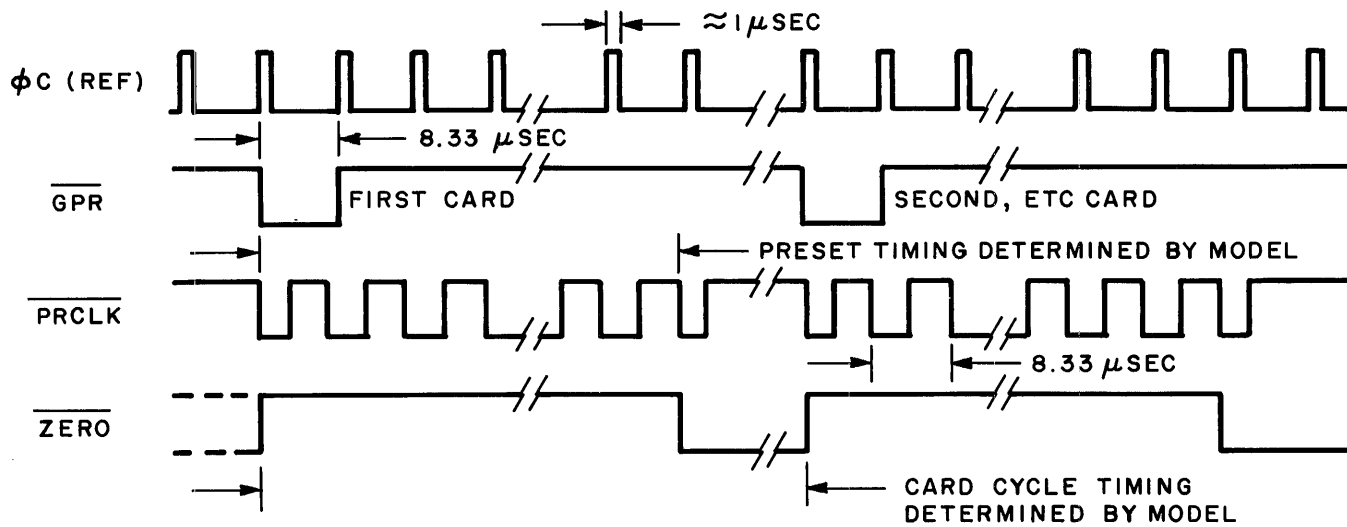

Figure 10. Preset Counter Logic Block Diagram

to "jam" set a hard-wired binary value into the Preset Counter and then when $\overline{\text{PRCLK}}$ is enabled, the counter counts up to all one's. This ZERO value is detected and defines the beginning of pseudo-column 0'.

OFFSET COUNT/STORAGE REGISTER

Since the leading edge of the card may arrive at the read station at an arbitrary time in relation to the TST signals, it is necessary to determine this "offset" so that later data column strobes generated from the occurrence of the TST1 signals will continue to be offset by the same amount for all 80 columns of that particular card. It should be noted that this offset interval between TST and the data column strobes will be different for each successive card, but is constant within each card.

The first TST2 after GPR starts the $\overline{\text{OSCLK}}$ signal, which is used to trigger the offset storage counter. These circuits count and store the time interval between the TST2 signal and the end of preset interval (i.e., beginning of pseudo-column 0'). If two TST2 signals occur before the preset timing is complete (as indicated by generation of $\overline{\text{ZERO}}$), the second TST2 resets the Offset Counter and its counting begins again (i.e., the shortest time interval between TST2 signals and end of preset timing is always selected). This "offset" interval is the synchronizing point that establishes the beginning of each of the remaining 80 data columns on that particular card.

The initialization reset for the Offset Counter is produced by $\overline{\text{TSTR}}$, which is generated by the first and/or second TST2 signal after GPR but before $\overline{\text{ZERO}}$ occurs. After the preset timing $\overline{\text{ZERO}}$ is produced, the $\overline{\text{PRCLK}}$, $\overline{\text{OSCLK}}$, and $\overline{\text{TSTR}}$ circuits are inhibited until the next GPR is generated; however, the second, fourth, sixth, etc., TST2 signal after $\overline{\text{ZERO}}$ is used to produce the $\overline{\text{OSR}}$ and $\overline{\text{OSUCLK}}$ signals. These two signals enable the Offset Comparator circuits to reproduce a time interval equal to the original offset count for each of the 80 columns of data in a punched card. In turn, this synchronizes various timing strobes within the card reader to allow for stable recovery of the data in each card column.

COMPARATOR LOGIC

As explained above, the Comparator Logic (figure 11) stores the offset interval and uses its value to generate the 80 data column strobes and index marks for external equipment synchronization.

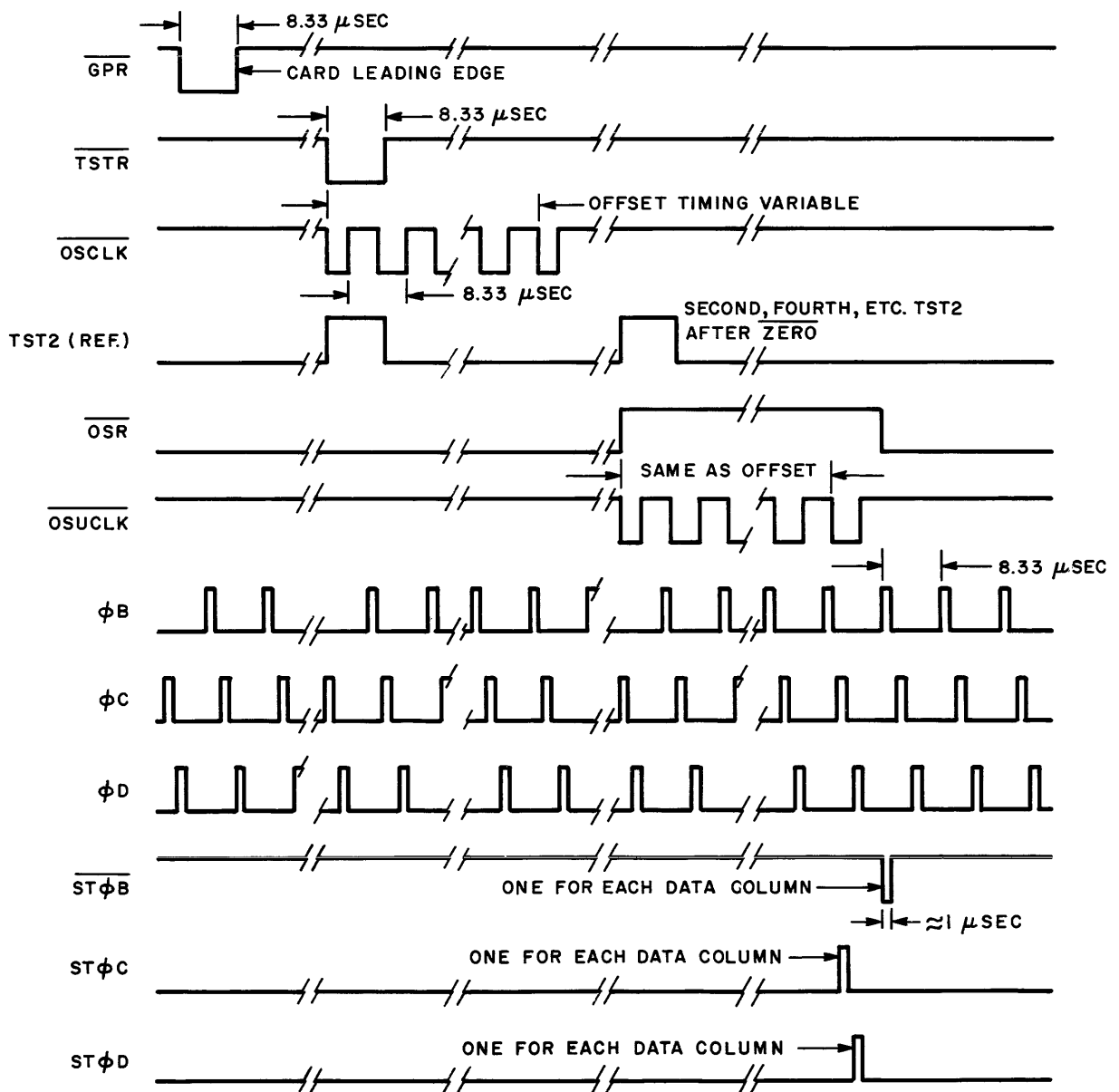
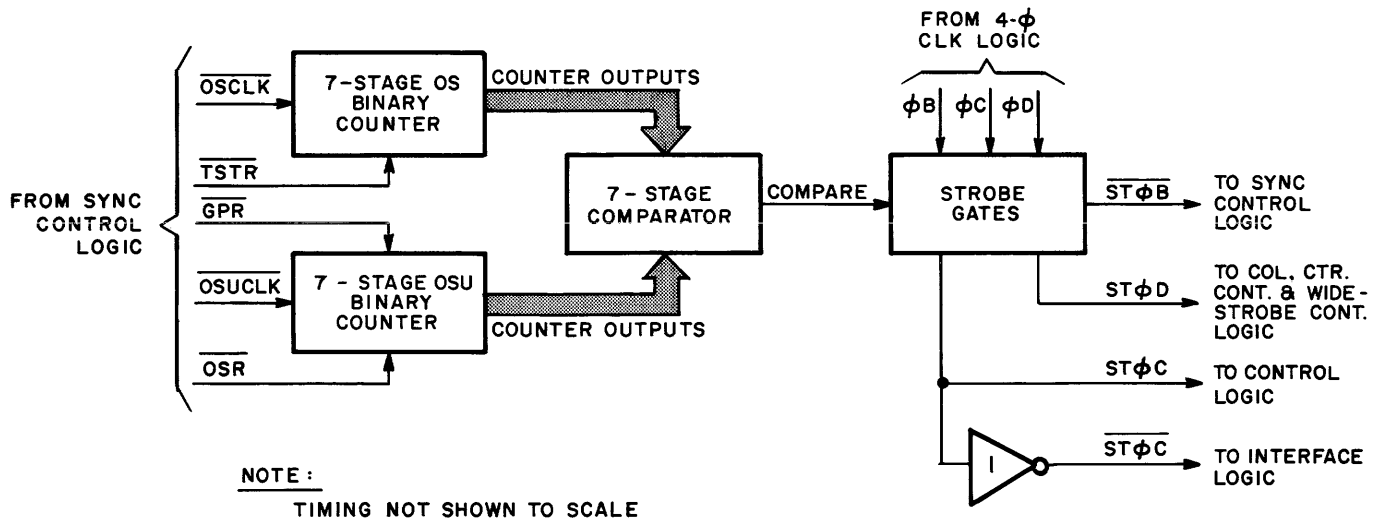

Figure 11. Comparator Logic Block Diagram

The $\overline{\text{OSR}}$ signal, which is raised by the second, fourth, etc., TST2 signal after the ZERO detect point occurs, allow the Offset Counter to be up-counted by the $\overline{\text{OSUCLK}}$ signal from sync control. A seven-stage, parallel comparator circuit recognizes when this count has equalled the binary value stored in the seven-stage offset counter. This up-count interval is regenerated 80 times as the card moves past the read station. Hence, by using this technique of re-establishing the value of the offset interval at the beginning of each card, the 80 data strobes are able to readjust for the arbitrary leading edge arrival.

The output of the comparator logic is a sequence of four pulses which actually initiate the various strobe actions. These are derived from the four-phase clock as follows: $\overline{\text{ST}\phi\text{C}}$ occurs first, followed by $\overline{\text{ST}\phi\text{D}}$, $\overline{\text{ST}\phi\text{A}}$, and $\overline{\text{ST}\phi\text{B}}$ ($\overline{\text{ST}\phi\text{B}}$ is used to reset the compare cycle).

WIDE-STROBE CONTROL LOGIC

The Wide-Strobe Control logic (figure 12) is used to produce the index marker strobes (IMST) and the column storage data strobe (CSDS). The $\overline{\text{ST}\phi\text{D}}$ signal, generated by the comparator logic, presets a seven-stage counter to a binary value determined by the card reader model. The counter then counts to all ones and in so doing, opens the Character Buffer gates for a time interval controlled by the hard-wired binary value. During the count cycle of the counter, any TRUE signals from the 12 read station sensors will be stored into the latch-type storage registers of the Character Buffer. At the end of the count cycle, the index marker strobe control circuits produce the six-microsecond wide IMST signal, which is routed through the column-counter logic to produce the Index Marks for external equipment synchronization. This insures that the data for the particular column being read is stored properly, allowing transients to settle out before the Index Mark is transmitted.

CHARACTER BUFFER/OUTPUT LOGIC

The output of the 12 phototransistor sensor arrays is gated to the Character Buffer by the wide strobe signal ($\overline{\text{CSDS}}$) as described above. Any TRUE level received from the read array during the duration of this $\overline{\text{CSDS}}$ enable will be stored and will appear on the output line. It will remain until the Character Buffer is reset by the $\overline{\text{ST}\phi\text{C}}$ signal. Refer to figure 13 for the block diagram and timing relationships. It is important to note that data is only guaranteed to be present from the trailing edge of the $\overline{\text{CSDS}}$ pulse to a point shortly before $\overline{\text{ST}\phi\text{C}}$. The guarantee period is different for each reader model and even though a generous delay is guaranteed, it is good practice to accept the data as soon as offered by

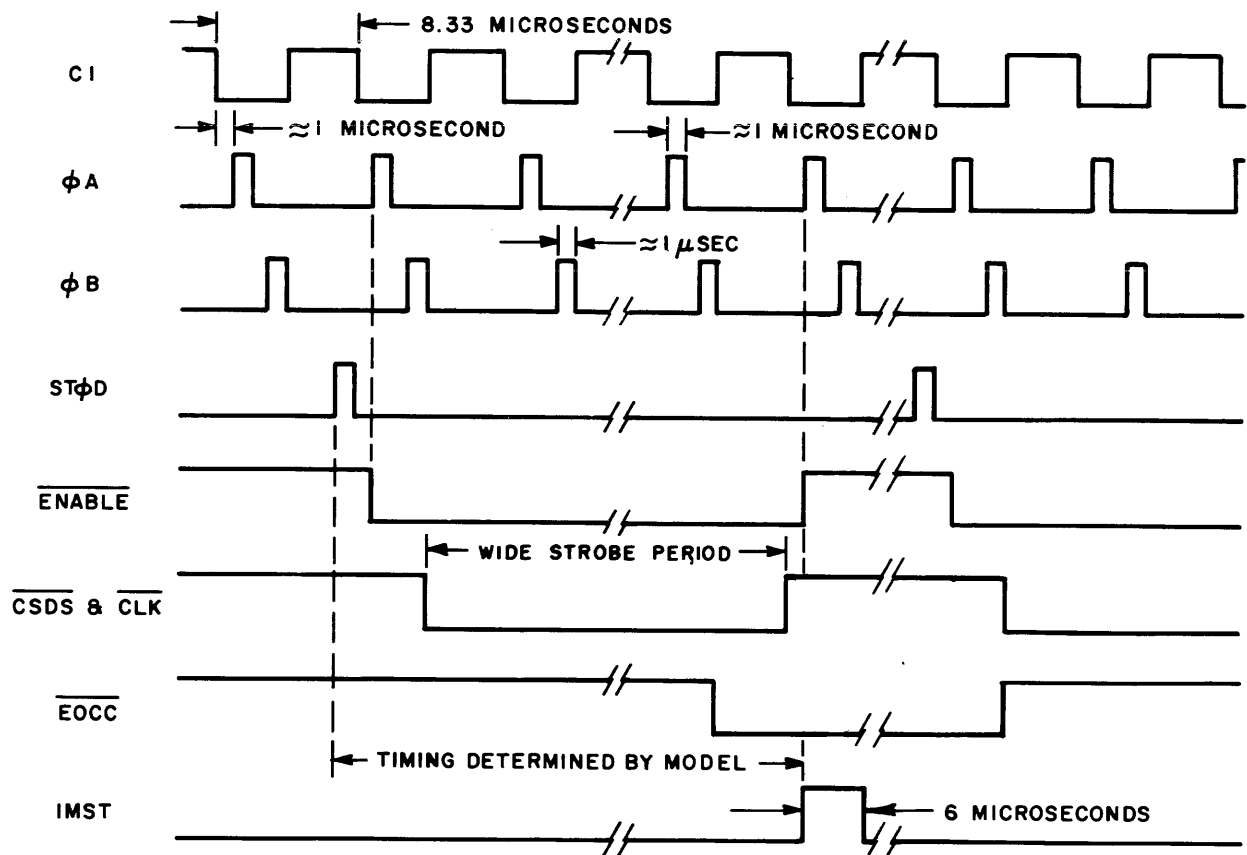
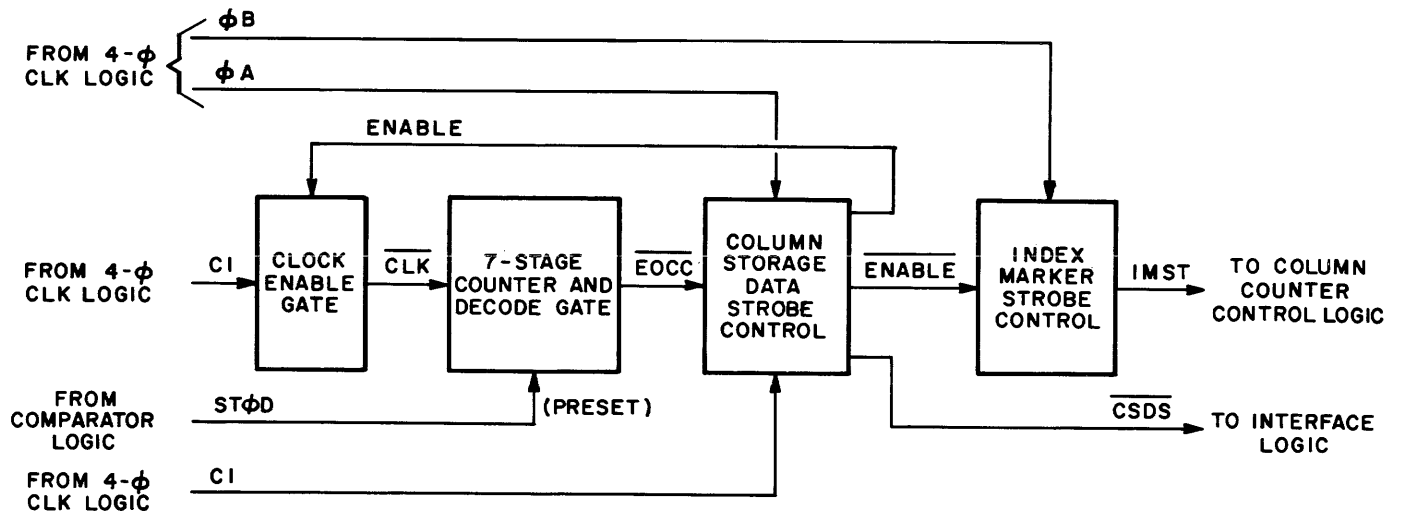

NOTES:

- (1) $ST\phi D$ SYNCHRONIZED TO CARD DATA COLUMNS.
- (2) TIMING NOT SHOWN TO SCALE.

Figure 12. Wide-Strobe Control Logic Block Diagram

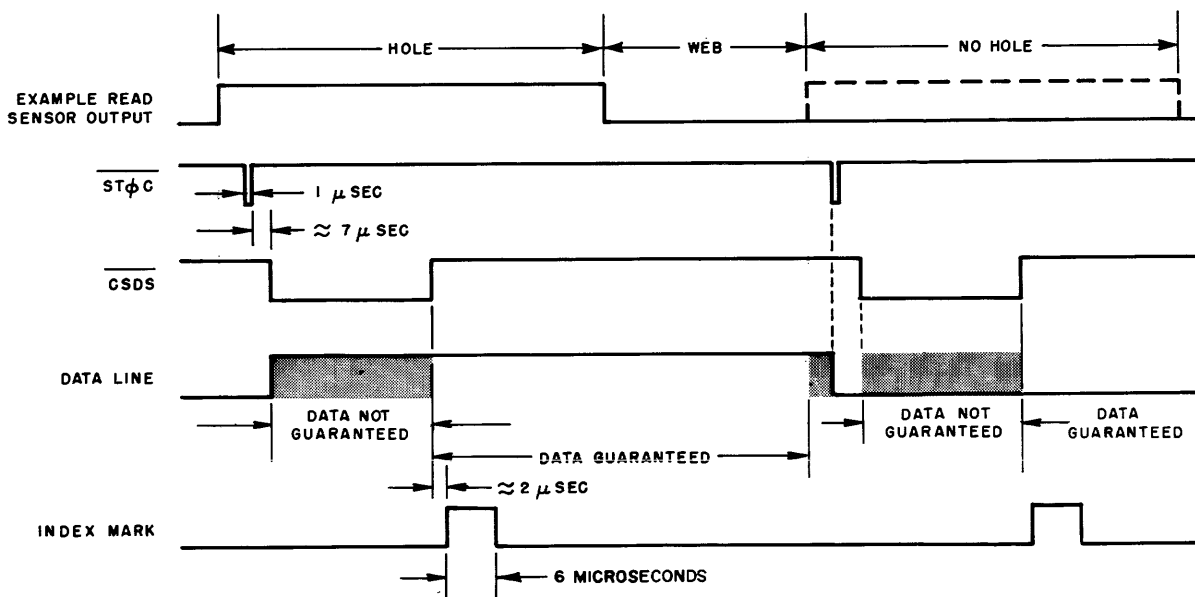
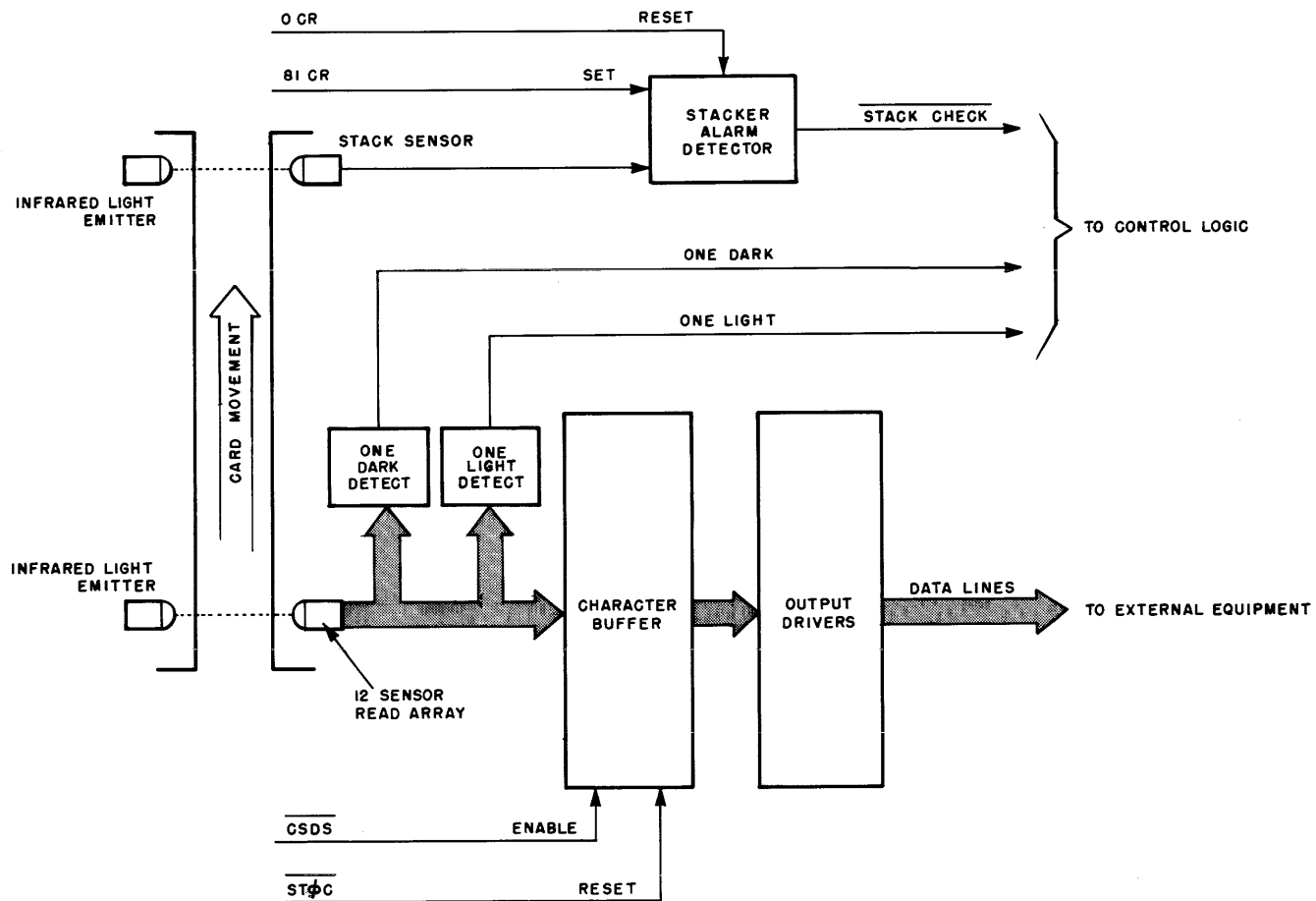

- NOTES:
- (1) TIMING NOT SHOWN TO SCALE.
 - (2) THE SPACING BETWEEN STφC, THE DURATION OF CSDS, AND THE GUARANTEE PERIOD OF THE DATA DIFFERS DEPENDING ON READER MODEL. REFER TO INTERFACE SECTION FOR SPECIFIC TIMING.

Figure 13. Character Buffer Storage Logic Block Diagram

the Index Mark. Either the leading or trailing edge of the Index Mark (IM) may be used to accept the data. The data signals will have settled by the occurrence of IM.

The ONE LIGHT and ONE DARK signals are derived if any one sensor goes light or dark. These signals are sent to the Control logic where they are interrogated at the proper time (see figure 6) to establish that the card does not have leading or trailing edge tears (Dark Check) and that the sensor array is responding to its stimuli properly (Light and Dark Check).

COLUMN COUNTER CONTROL LOGIC

The Column-Counter Control logic (figure 14) is initialized by GPR to begin counting the number of data columns read as the card moves past the read station. The seven-stage binary counter is triggered by $ST\bar{O}C$, which is synchronized to the data column of a card. The counter decode gating recognizes $0CR$ (pseudo-column 0) and $81CR$ (pseudo-column 81) to produce the two dark checks ($\bar{D}CKS$). This provides the dark check of the read station at the beginning and end of the card being read. The counter decode gating circuits also detect $1CR$ (enable) and $81CR$ (disable) to control the Index Marker generation. The $84CR$ count recognition is used to initiate the Light Check and to indicate the end of the read cycle. This signal also re-establishes the readiness of the card reader to accept the next pick command (provided no alarm conditions have occurred for the card being processed).

CONTROL LOGIC

The Control logic (figure 15) contains the error alarm detection circuits, ready-condition detect circuits, and pick control and gating circuits.

The Pick Check control circuits signal the fact that a card has been picked (i.e., no $\bar{P}CK$ alarm signal has occurred), to the Read Check Control logic. Unless two successful Dark Checks are received, an automatic Dark Check alarm is generated. In like manner, a successful Light Check must be received prior to the $\bar{84}CR$ (end of card read cycle) to prevent a READ CHECK. In other words, a READ CHECK is not generated when this logic senses the successful occurrence of two dark checks (0th pseudo-column and 81st pseudo-column), and that a successful light check has occurred prior to the generation of $\bar{84}CR$.

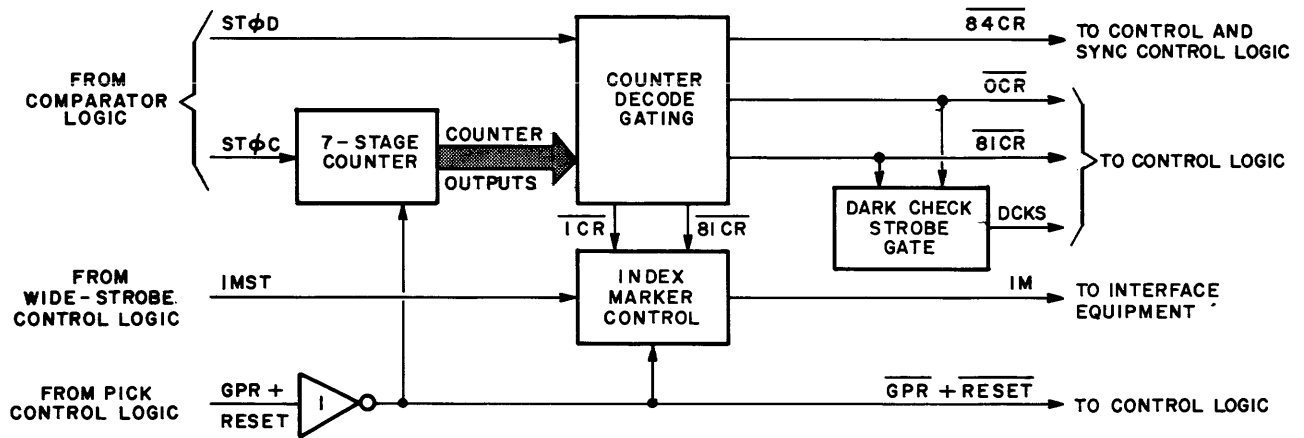

NOTE :

- (1) TIMING NOT SHOWN TO SCALE.
- (2) GPR OCCURS AT LEADING EDGE OF CARD.

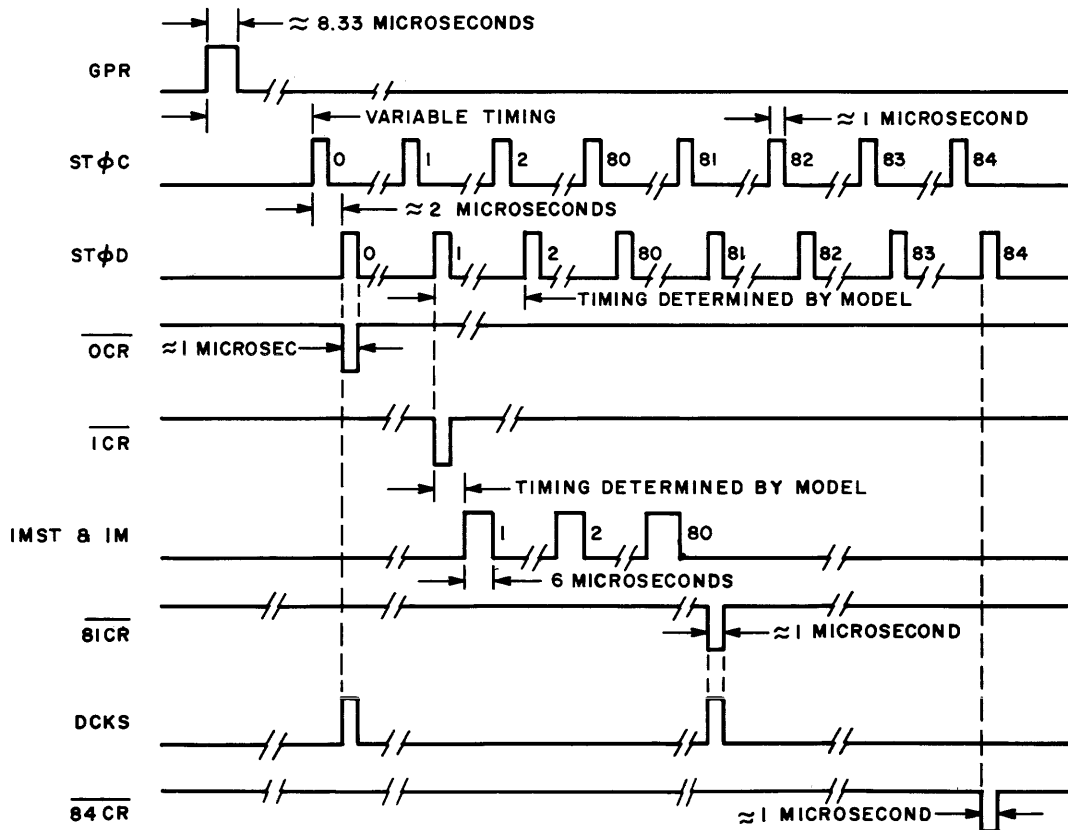
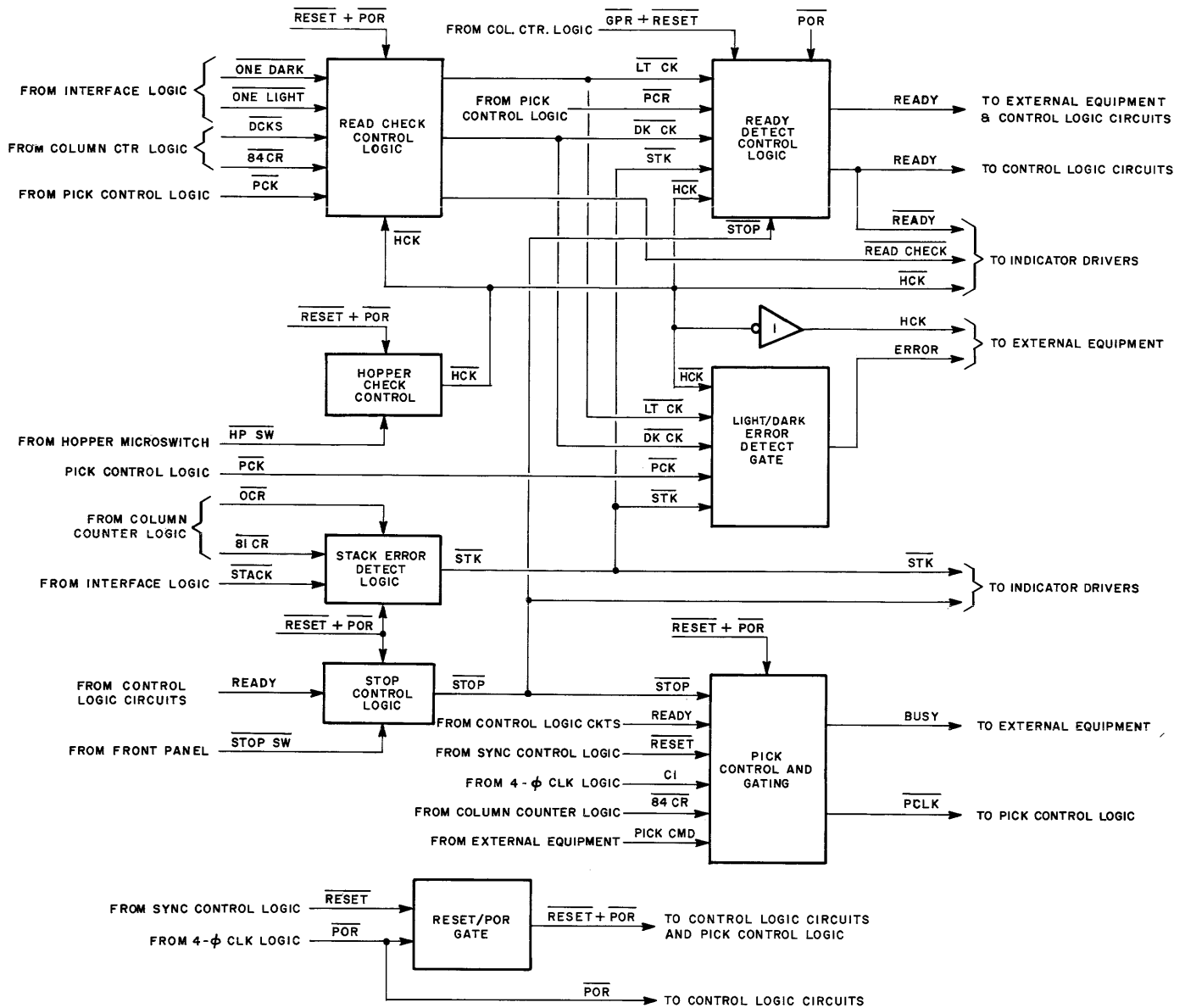

Figure 14. Column Counter Control Logic Block Diagram



NOTE:
TIMING NOT SHOWN TO SCALE

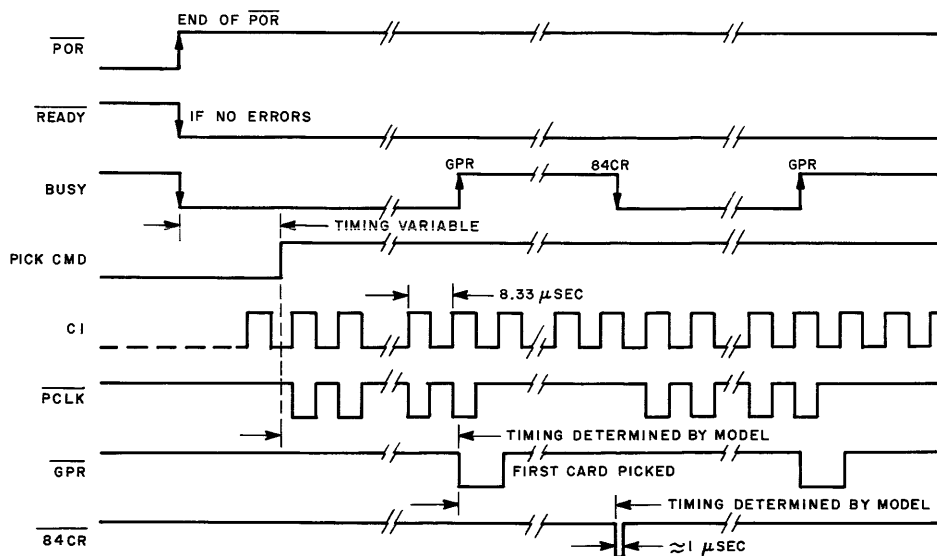

Figure 15. Control Logic Block and Timing Diagram

The Error Detect gate recognizes a data error condition from any of the above detect circuits and provides an ERROR signal to the external equipment. Simultaneously the particular alarm condition indicator on the card reader front control panel is illuminated. The Hopper Check Control circuits utilize the microswitch in the riffle cap to sense when the hopper is empty of cards. Another microswitch in the stacker follower assembly senses when the output stacker is full of cards. Either of these conditions will generate the $\overline{\text{HCK}}$ alarm.

The Stop Control logic detects the fact that the STOP pushbutton switch on the card reader front control panel has been depressed or that a light/dark check error has occurred to lower the READY line. The Ready Detect control logic utilizes the fact that no alarm conditions exist to raise the READY line for external program control and internal control use. The READY line is lowered at the instant of error detection but the card reader operation is not stopped until after the present card is processed completely.

MOTION CHECK LOGIC

The stack check sensor (see figure 13) is located at the exist of the card track and detects that the tail of a card is clear of the card track (hence, fully seated in the output stacker). The Stack Alarm logic is designed to test that the stack sensor made a dark-to-light transition (i.e., track clear) between the time a 81CR signal occurs (card tail leaving the read station) and the OCR signal of the next card. Should this transition not have taken place, a STACK CHECK alarm is generated. This signal is combined with the Pick Check alarm to generate a MOTION CHECK alarm to the external equipment should either condition occur. The card reader is stopped and the READY line goes FALSE.

LAMP DRIVERS

The lamp drivers amplifiers provide the current drive for the alarm indicators on the front control panel. The LAMP TEST input to the lamp driver circuits enables the output drivers for all indicators simultaneously, providing the operator with a rapid check to determine that all #328 bulbs are good.

INTERFACE

GENERAL

This section covers the interface between the M Series punched card readers and the equipment into which it transfers data.

TIMING

In interfacing the M Series card readers to an external system or card reader controller, the designer should appreciate that three separate categories of interface signals are being dealt with. The first are the signals which control and report the status of card processing, the second are the data signals themselves with their associated index marks, and the third are the various alarm signals provided. In the description following, the designer should refer to the timing diagram shown in figure 16.

Pick Control

The PICK COMMAND initiates the card read cycle, and depending upon its duration, the card reader will either continuous run or operate in a card-at-a-time mode. This signal can be presented to the reader at any time, but the reader will only accept it when the READY line is TRUE. The READY signal indicates that the card reader is cleared of errors and is ready to receive a PICK COMMAND from the external program control. A visual indication of the READY line is the green RESET indicator on the front control panel.

The conditions which must be present for the READY line to be TRUE are:

1. Power applied and the 3 second run-up completed.
2. The input hopper has been loaded.
3. Depressing the RESET pushbutton switch will bring the READY line TRUE.

Should all of the above conditions be satisfied, the presence of a PICK COMMAND signal will generate the PICK pulse to the picker solenoid. The first card is introduced into the card track, and after a delay (see A, figure 16), the leading edge will arrive at the read station. The BUSY signal will go TRUE as soon as the leading edge of the card enters the read station.

To initiate the card pick cycle, the PICK COMMAND must be present for at least 1 microsecond (us) concurrently with the READY signal. Once the pick cycle is initiated, the PICK COMMAND line is ignored until the BUSY signal goes

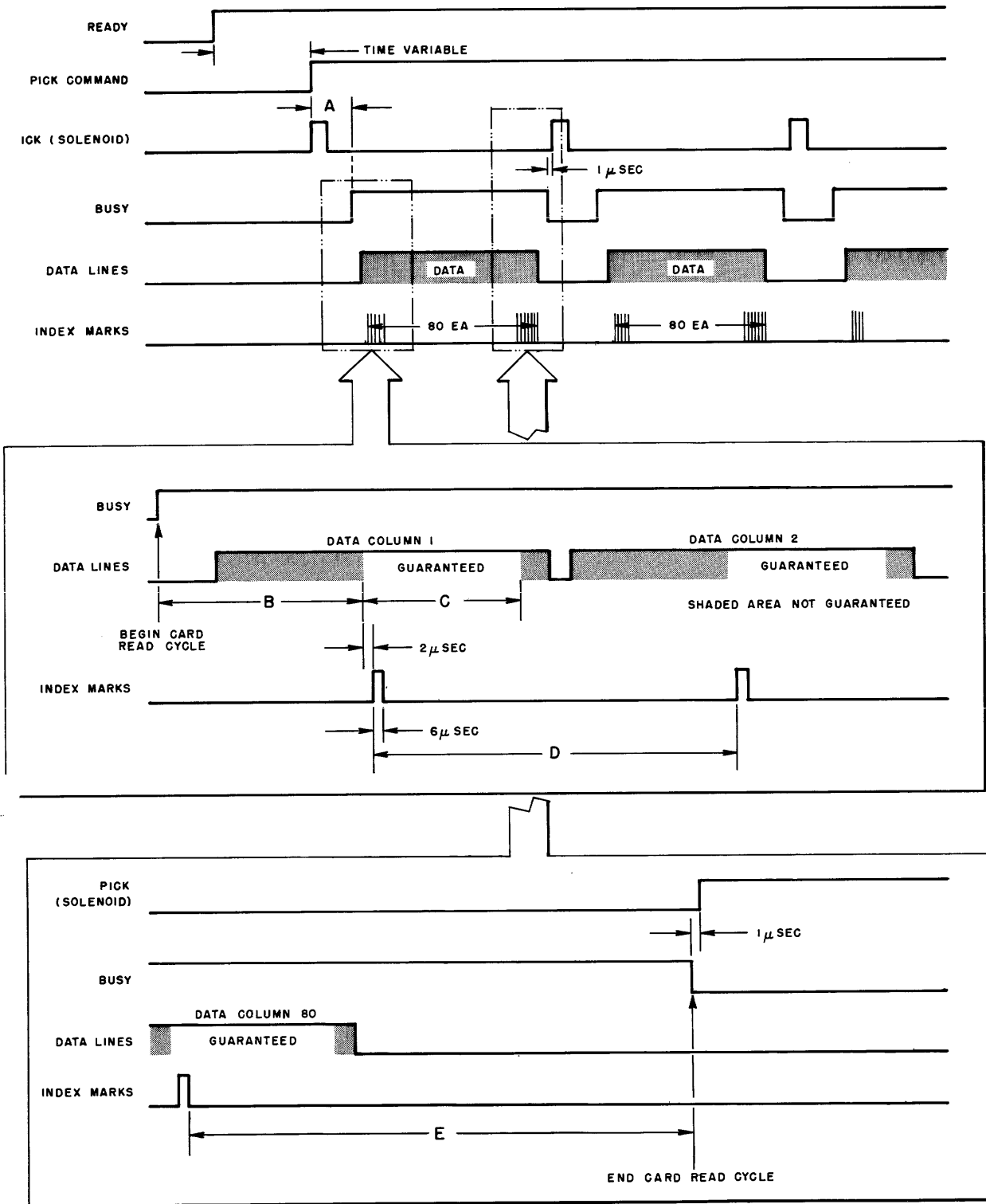

NOTE:
WAVEFORMS NOT SHOWN TO SCALE.

MODEL	A (MIN)	B	C	D	E	CARD PICK CYCLE
M200	24	6250	1314	2014	8050	200
M300	24	2600	435	870	102,660	200
M600	24	2600	435	870	3480	100
M1000	15	1860	240	478	1910	60
M1200	14	1120	240	405	1529	50
	M SEC	μ SEC	μ SEC	μ SEC	μ SEC	M SEC

Figure 16. Standard Interface Timing for M Series Readers

FALSE, indicating the end of the card read cycle. In card-at-a-time operation, it is suggested that the PICK COMMAND be retained TRUE until receipt of the column 1 index mark. In the continuous run mode, the PICK COMMAND may be left in the TRUE condition and a new PICK signal will be automatically generated within 1 us of the BUSY signal going FALSE.

Should the picker fail to engage the card, the Pick Control logic will wait 50 milliseconds (ms) and automatically try again. It will continue to generate a PICK pulse every 50 ms until 6 attempts have been made. After 6 attempts have been unsuccessful (300 ms), a PICK CHECK alarm will be generated, disabling the READY line.

Data Readout

The card read cycle starts with the recognition that the card leading edge has entered the read station. At this time the BUSY line goes TRUE. Eighty equally spaced Index Marks of 6 us duration are generated while the BUSY signal is present. The time spacing of the Index Marks and the BUSY signal are shown by intervals B, D, and E on figure 16.

It can be seen from the timing diagram that data signals may appear on the data output lines before the occurrence of the associated Index Mark. Since torn webs are sometimes encountered which could partially obscure the hole, all Documentation card readers feature a wide data acceptance interval to provide greater tolerance to this damage. During this interval, any signal from the read station sensors indicates a hole, and therefore is recognized as a valid data bit and is stored into the Character Buffer. Since the contents of the Character Buffer are subject to change throughout this interval, the data is not guaranteed until the end of the acceptance interval. This period is terminated 2 us prior to the Index Mark.

By the time the Index Mark is generated, the data will have been read, stored, and the data lines should have settled. Data levels are guaranteed to remain on the output lines available for transfer to the external equipment for interval C. The data lines may actually remain TRUE longer than the guaranteed period; however, the absolute duration of the data signal is not controlled as it will vary slightly due to variations in the track speed of the card reader.

Alarms

A description of the standard alarm signals provided in the M Series reader follows:

Hopper Check

The HOPPER CHECK signal remains FALSE during normal card reader operation, but goes TRUE if either the input hopper is empty or the output stacker is full. If the input hopper is empty and the SHUTDOWN switch is in AUTO position, the blower is also automatically switched off; when the input is reloaded and RESET pressed, the blower is automatically re-energized.

When the last card leaves the input hopper, the switch which senses the empty condition immediately signals a HOPPER CHECK and disables the READY signal. This occurs at about the time that the 16th data column is being read. The reader continues the read cycle; however, when the BUSY line next goes FALSE the reader is stopped. In the case of a full output stacker, the HOPPER CHECK signal only appears at the end of the read cycle during which it occurred.

Error

The ERROR signal is produced by failure of the light or dark check. This usually indicates that a card has a tear at the leading or trailing edge (DARK CHECK). If the read station should experience an emitter/sensor failure while reading a card, the LIGHT CHECK will pick it up. Either type of failure will be signalled by the ERROR line going TRUE and a READ CHECK indication on the front panel.

Motion Check

The MOTION CHECK signal is a composite of the PICK CHECK and STACK CHECK alarm. Both alarms are conditions requiring operator intervention and are furnished to the interface as a single alarm line. The condition is displayed on the front panel indicator lights as either a PICK CHECK or a STACK CHECK. The MOTION CHECK signal will occur within 300 ms of the initiation of an unsuccessful pick attempt or in time to inhibit the picking of the second card after the stacker sensor detects that a card is not completely clear of the card track.

CONNECTORS

The 38 pin output connector provides access for all control, data and alarm lines. A separate twist-lock connector provides entry for AC power. The output connector is Elco part no. 00-8016-038-000-707 and the mating connector is Elco part no. 00-8016-038-217-704. This mating connector assembly is available from Documation and is shipped unassembled as a kit with connector base, cover and 38 solder type pins (#60-8017-0513).

The power connector is Hubbell part no. 7486. The mating connector is Hubbell part no. 7484. The mating AC power connector is supplied on the standard accessory power cord; however, it is identified in case it is desired to fabricate a special power interface.

The standard M Series pin assignment configuration is given in the following table:

Signal Connector

SIGNAL CONNECTOR PIN LIST

PIN	SIGNAL	DESCRIPTION	PIN	SIGNAL	DESCRIPTION
A ✓	D12	Row 12 Data <i>white-blue</i>	X ✓	D7 (RET)	<i>black-green</i>
B ✓	D11	Row 11 Data <i>blue-white</i>	Y ✓	D8	Row 8 Data <i>green-black</i>
C ✓	D0	Row 0 Data <i>blue-black</i>	Z ✓	D9	Row 9 Data <i>brown-white</i>
D ✓	D1	Row 1 Data <i>blue-green</i>	AA ✓	IM	Index Mark <i>orange-black</i>
E ✓	D12 (RET)	<i>yellow-green</i>	BB ✓	RDY	Ready <i>blue-black</i>
F ✓	D11 (RET)	<i>white-brown</i>	CC ✓	D8 (RET)	<i>red-brown</i>
H ✓	D0 (RET)	<i>red-green</i>	DD ✓	D9 (RET)	<i>brown-red</i>
J ✓	D1 (RET)	<i>black-brown</i>	EE ✓	IM (RET)/GRD	Signal Ground <i>orange-white</i>
K ✓	D2 <i>green-red</i>	Row 2 Data	FF ✓	RDY (RET)	<i>white-orange</i>
L ✓	D3 <i>red-blue</i>	Row 3 Data	HH X	ERROR	Error
M ✓	D4 <i>brown-black</i>	Row 4 Data	JJ X	HCK	Hopper Check
N ✓	D5 <i>black-dark brown</i>	Row 5 Data	KK X	MOCK	Motion Check
P ✓	D2 (RET)	<i>white-grey</i>	LL ✓	PC	Pick Command <i>orange-red</i>
R ✓	D3 (RET)	<i>red-orange</i>	MM ✓	BSY	Busy <i>green-white</i>
S ✓	D4 (RET)	<i>grey-white</i>	NN X	Error (RET)	
T ✓	D5 (RET)	<i>white-green</i>	PP X	HCK (RET)	
U ✓	D6 <i>black-grey</i>	Row 6 Data	RR X	MOCK (RET)	
V ✓	D7 <i>grey-black</i>	Row 7 Data	SS ✓	PC (RET)	<i>red-grey</i>
W ✓	D6 (RET)	<i>black-blue</i>	TT ✓	BSY (RET)	<i>grey-red</i>

POWER CONNECTOR PIN LIST

PIN	SIGNAL
W	Safety ground (green)
X	Neutral (white)
Y	115 Volts (black)

SIGNAL CHARACTERISTICS

The standard interface is supplied as the output of TTL type 7404. Signal sense is specified as a Logical TRUE and is a positive level, Logical FALSE is a ground level. Circuit characteristics are shown in figure 17. Other output drive configurations are available.

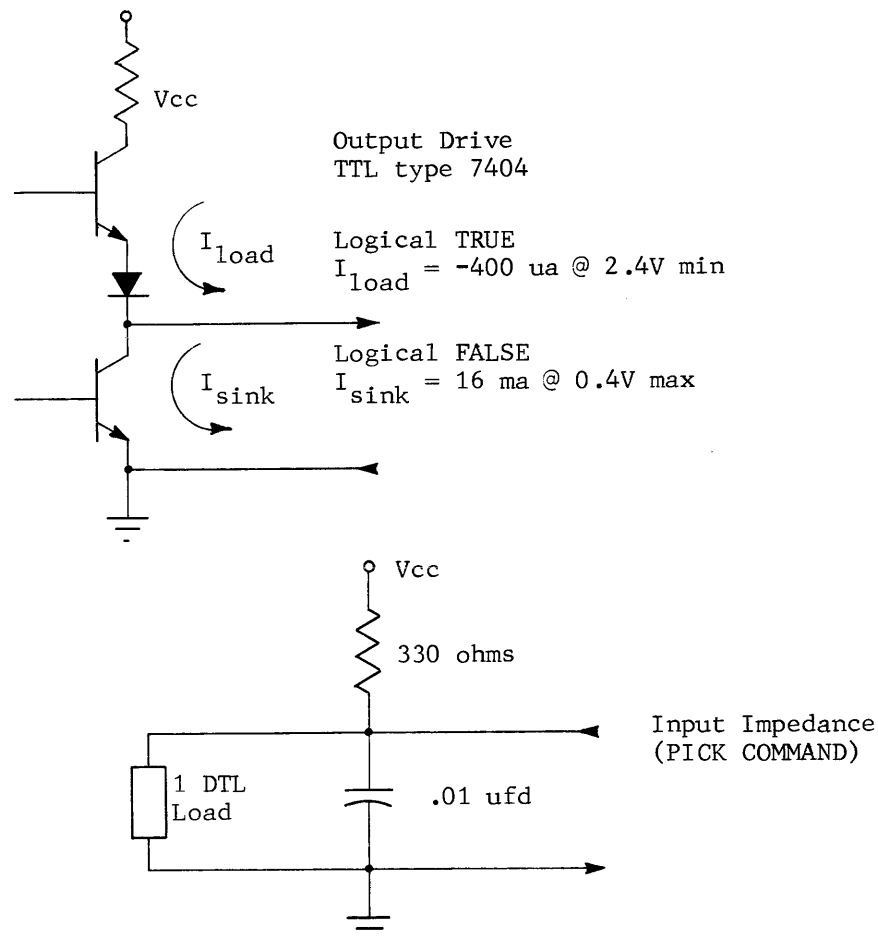

Figure 17. Circuit Characteristics

GROUNDING

Grounding within the M Series card readers maintains AC power and signal ground separate. Signal ground is the logic power return (Vcc return) and is transformer isolated from the AC power distribution system. The chassis is protected by connection to the safety wire (green) in the AC power cord.

It is recommended that twisted pair cable be used to connect the M Series card readers to external equipment. The signal returns should be terminated as close as possible to the signal receivers. It should be noted that pin EE (Index Mark return) is designated as SIGNAL GROUND on the pin assignment chart. If twisted pair interconnection is not used, it is recommended that pin EE be connected to the external equipment signal return.

PREVENTIVE MAINTENANCE

GENERAL

The following paragraphs provide information for preventive maintenance and general care of the M Series card readers. The M Series card readers are of rugged construction and are designed to provide many hours of failsafe, reliable operation; as such, preventive maintenance consists primarily of routine cleaning.

CLEANING

Picker Shoe

IMPORTANT

AFTER EACH 40 HOURS OF OPERATION, THE NEO-PRENE SURFACE OF THE PICKER SECTOR SHOULD BE WIPED WITH A SOLVENT SUCH AS DENATURED ALCOHOL OR LACQUER THINNER.

This will remove the glaze buildup from the ink which rubs off of the cards. This is especially prevalent where new cards are used exclusively. If this glaze is allowed to remain, it reduces the coefficient of friction of the picker sector to the point that erratic pick operation may result.

After each 160 hours of operation, the picker sector should be examined to see if any of the vacuum holes have become plugged with lint, trash, or card meal which the solvent scrub has failed to dislodge. If so, gently push this debris through the holes with a paper clip while the reader is on. The vacuum system will remove the debris.

Casting Assemblies

After each 160 hours of operation, the card track should be cleaned. Using a 5/64 Allen wrench, remove four button head screws (3), figure 20, holding top panel cover. Remove this cover and use a vacuum cleaner to remove any card debris buildup around the picker and stacker castings. Use a small brush to clean around the picker and stacker rollers and picker sector.

Cooling Fan

The cooling fan air-intake screen performs the function of preventing dirt and dust from entering the card reader interior. Depending upon the

operational atmosphere, the screen should be cleaned as necessary. Use a flat-blade screwdriver and remove the screen (Figure 18); then clean in a solvent or use a vacuum cleaner as necessary.

Exterior Cleaning

The exterior M Series Card Readers should be cleaned as often as practical. Wipe the exterior with a clean, lint-free cloth saturated with a mild solvent such as denatured alcohol or household ammonia after each 40-hour operational period. If persistent dirt buildup is present, the exterior should be rubbed down with a heavier solvent. Attention to this routine will keep the anodized finish of the reader with a like-new appearance indefinitely.

LUBRICATION

Rotary Solenoid

The rollers of the rotary solenoid normally require grease only after 40 million cards have been processed through the reader. Since there is a possibility that the grease may dry out in certain low humidity localities, it is advised to lubricate these rollers every six months. Apply one drop of Ledex

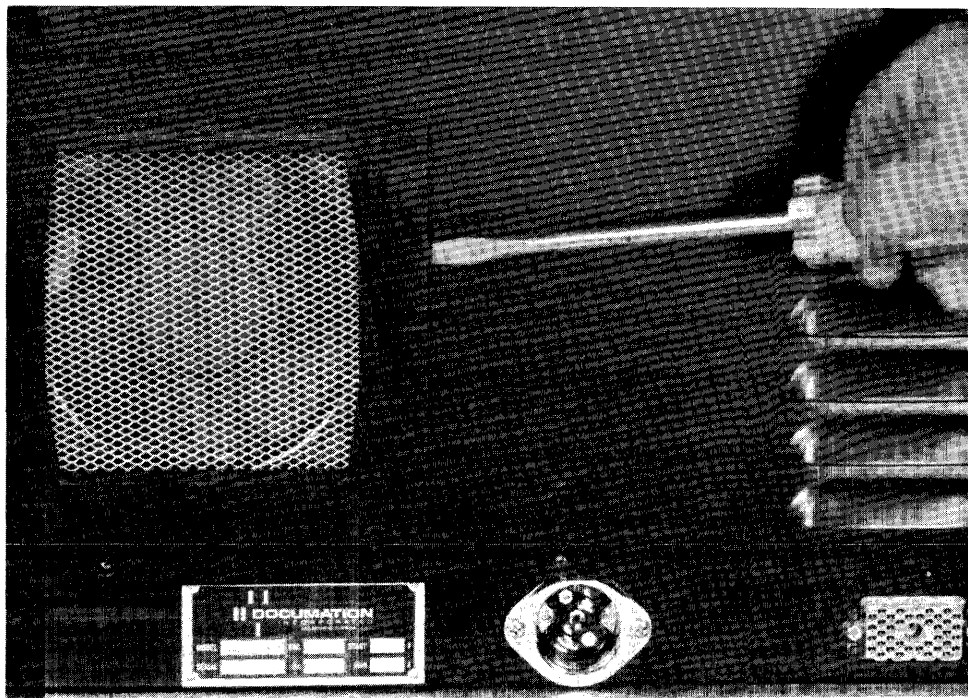

Figure 18. Removal of Fan Screen

No. 2 lubricant to each of the three roller grease points (figure 19). A lubricant kit is available from Ledex Inc., Dayton, Ohio (Part No. 124048-001) or from Documation, Incorporated.

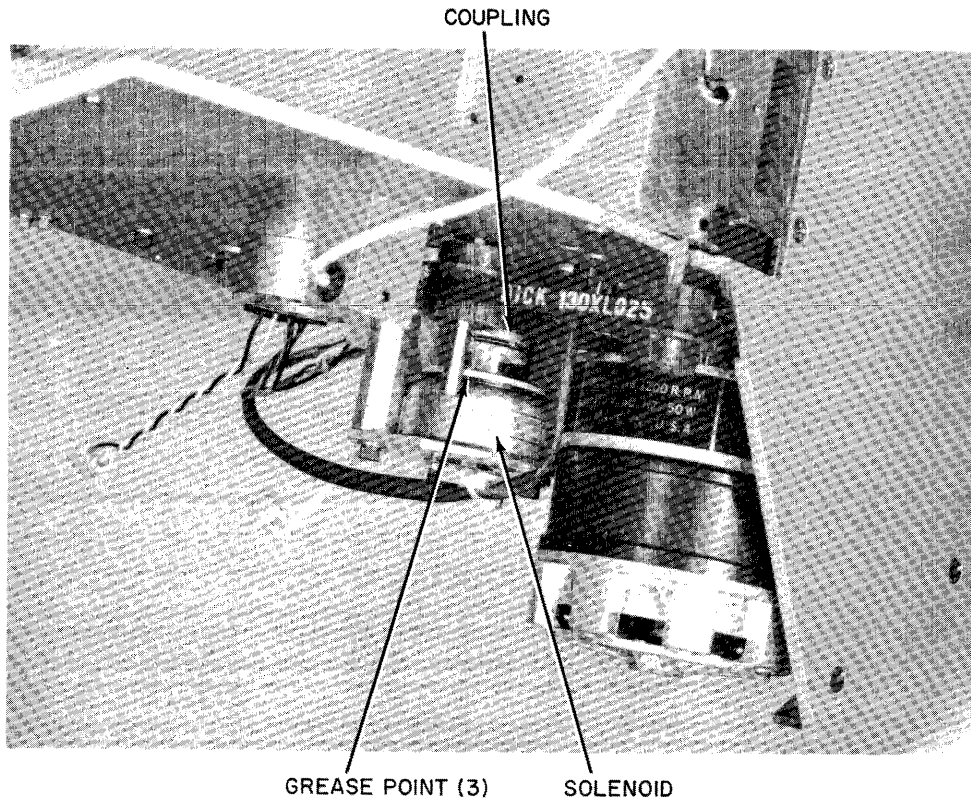

Figure 19. Solenoid Lubrication

REPAIR

GENERAL

The following repair procedures detail step by step methods for those parts for which replacement may be required during the life of the reader. It is recommended that these procedures are followed closely and performed by a person familiar with tools, their use and assembly/disassembly techniques.

REPAIR PROCEDURES TABLE OF CONTENTS

<u>Title</u>	<u>Page No.</u>
1. Replacement of Hopper Empty Switch	41
2. Adjustment of Picker Sector Travel	41
3. Adjustment of Tension on Main Drive Motor Belt	41
4. Adjustment of Stacker Tray Spring	44
5. Stacker Shaft Support-Bearing Replacement	44
6. Replacement of Belt on Vacuum Pump Motor Assembly	46
7. Replacement of Main Drive Motor Belt	49
8. Replacement and Adjustment of Magnetic Pickup	52
9. Replacement of Solenoid	52
10. Replacement of Roller Bearings, Read Head or Light Station	55
11. To Replace Roller Assembly Bearings	57
12. To Replace Read Head	58
13. To Replace Light Station	58
14. Replacement of Picker	60
15. Replacement of Stacker Full Switch	61
16. Replacement of Stacker Photocell	61

REQUIRED TOOLS

The following tools are required to perform assembly/disassembly on the M Series Card Readers.

TOOL DESCRIPTION	MANUFACTURER/PART NUMBER SPECIAL TOOLS
1. 1/16" - Allen Screwdriver	
2. 3/32" - Allen Wrench (long arm)	
3. 5/64" - Allen Wrench (long arm)	
4. 7/64" - Allen Wrench (long arm)	
5. 1/8" - Allen Wrench (long arm)	
6. 9/64" - Allen Wrench (long arm)	
7. .050" - Allen Wrench (short arm)	
8. 1/16" - Allen Wrench (short arm)	
9. AMP Extraction Tool	AMP 91022-1
10. "AMP Leaf Contact" Extraction Tool	AMP 465195-2 or 465275-1
11. "AMP Modified Fork" Contact Extraction Tool	AMP 91037-2
12. "AMP Mod IV" Contact Extraction Tool	AMP 91029-1A
13. Deutsch Insertion/Extraction Tool	NAS 1664-16
14. Elco Extraction Tool	Elco 061877-02
15. Elco Insertion Tool	Elco 061742-04
16. Feeler Gauge Set 0.0015" thru 0.025"	
17. Flat Nose Pliers	
18. Knife Blade - 2 1/2" blade	
19. Medium Flat Blade Screwdriver 3" long	
20. Medium Flat Blade Screwdriver 6" long	
21. 6" Metal Scale, decimal/fraction per inch	
22. 1/4" - Open End or Socket Wrench	
23. 1/32"- Open End or Socket Wrench	
24. 7/16"- Open End or Socket Wrench	
25. #1 Phillips Screwdriver 6" long	
26. #2 Phillips Screwdriver 6" long	
27. Printed Circuit Card Extender	Documation P/N 1040405
28. #2 Retaining Ring Remover	
29. Side Cutter	
30. Solder Removal Tool	
31. 60-watt Soldering Iron	
32. 32-oz. Spring Scale	

REPLACEMENT OF HOPPER EMPTY SWITCH

1. Using a flat blade screwdriver or a 5/64 Allen wrench, LOOSEN five DZUS fasteners or remove five 6 x 32 button head screws (1) retaining top cover, figure 20.
2. Lift top cover sufficiently to reveal the control panel connector, figure 22, and disconnect the control panel connector. The top cover may now be removed.
3. Using a 3/32 Allen wrench, remove two socket head screws holding raffle cap, figure 22.
4. Remove two leads from hopper empty switch, figure 22.
5. Using a 1/16 Allen wrench, remove two button head screws holding switch, figure 22.
6. Replace switch and adjust so that microswitch is mechanically actuated with card in hopper and disengaged with hopper empty.
7. Reassemble in reverse order of disassembly.

ADJUSTMENT OF PICKER SECTOR TRAVEL

1. Perform steps 1 and 2 of Replacement of Hopper Empty Switch Procedure.
2. Using a 5/64 Allen wrench, LOOSEN two 6 x 32 socket head screws (2) holding picker stop, Figure 22.
3. Adjust picker stop so that the rear edge of the last row of holes in picker sector is in a vertical line with the pick vacuum set screws' centerline, Figure 23. Tighten the two socket head screws holding the picker stop.
4. Using a 9/64 Allen wrench, LOOSEN the two 8 x 32 socket head screws (3) retaining the picker bumper, Figure 22.
5. Adjust the picker bumper so that a card picked by hand just makes contact with the first set of rollers. Tighten the two socket head screws holding the picker bumper.
6. Reassemble in reverse order of disassembly.
7. Using a Phillips screwdriver, LOOSEN the throat block screw and adjust throat block for .007" to .008" clearance between picker sector and throat block, Figure 23. Tighten throat block screw and check reader for proper pick action.

ADJUSTMENT OF TENSION ON MAIN DRIVE MOTOR BELT

1. Perform steps 1 and 2 of Replacement of Hopper Empty Switch Procedure.
2. Using a Phillips screwdriver, LOOSEN three main drive motor mounting screws (4), figure 22.

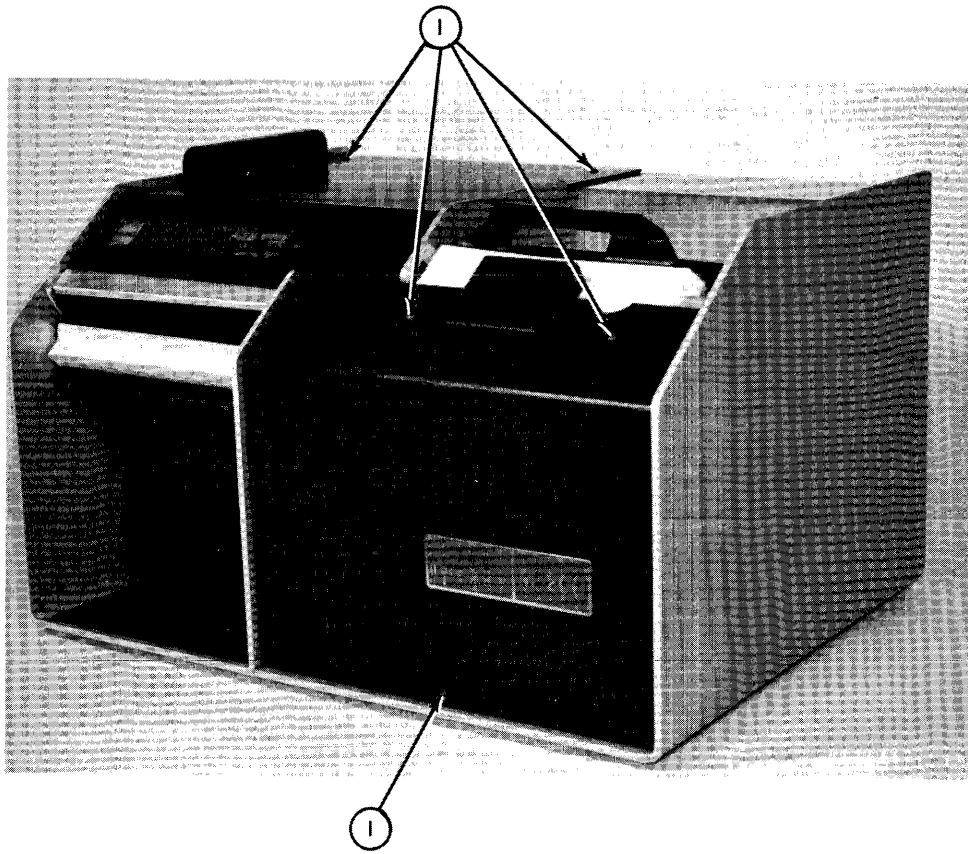

Figure 20. Three-Quarter Front View

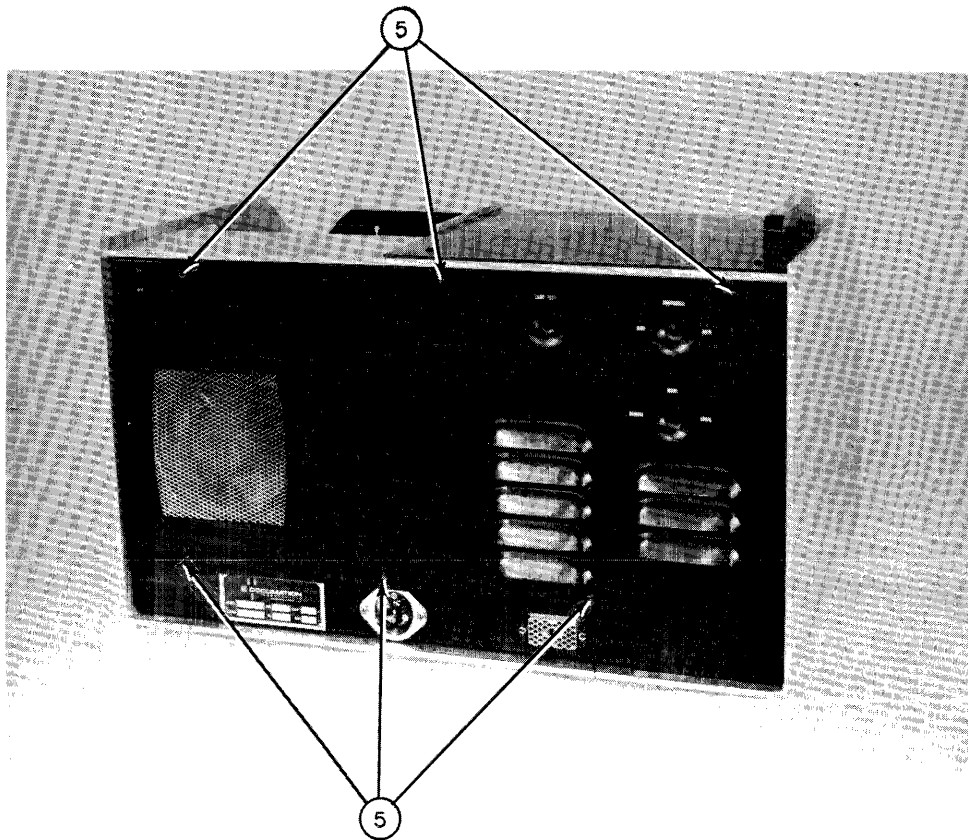

Figure 21. Three-Quarter Rear View

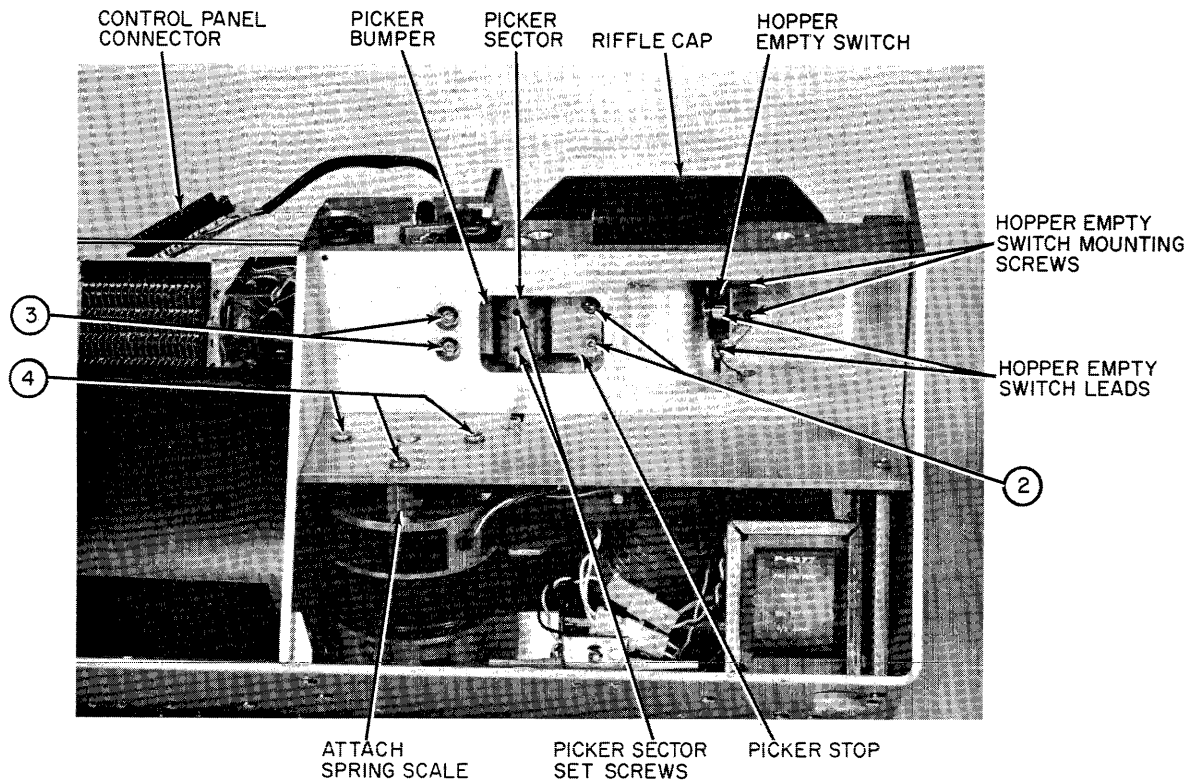

Figure 22. Partial Front View, Cover Removed

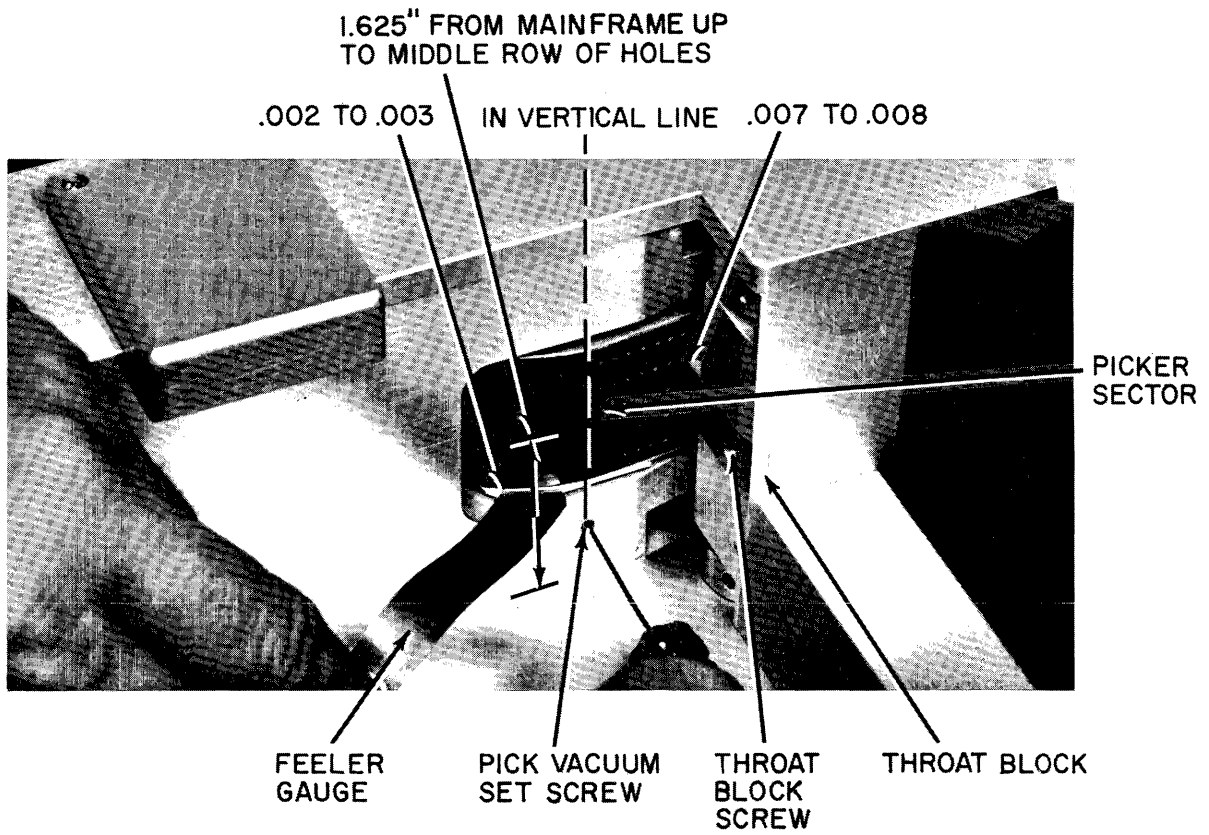

Figure 23. Picker Sector Adjustment

3. Attach a 32-ounce spring scale with a round hook end to the front main drive motor standoff, figure 22.
4. Apply 24-ounces of force to the motor standoff. This will apply the correct tension to the main drive motor belt.
5. With this force applied, tighten the three main drive motor mounting screws.

CAUTION

BELT TENSION IS A CRITICAL ADJUSTMENT;
EXERCISE CARE THAT TENSION IS CORRECT TO
PREVENT EXCESSIVE BELT AND MOTOR SHAFT
BEARING WEAR.

6. Readjust magnetic pickup using step 8 of Replacement and Adjustment of magnetic pickup.
7. Reassemble in reverse order of disassembly.

ADJUSTMENT OF STACKER TRAY SPRING

1. Perform steps 1 and 2 of Replacement of Hopper Empty Switch Procedure.
2. Locate stacker tray spring behind left side of stacker tray-facing reader.

Use the following guidelines to adjust the stacker tray spring:

3. The six holes in the spring plate may be termed the stacker tray rate adjustment. Generally, if the cards being read are heavy (very few punches), the spring will be placed in one of the holes toward the front of the plate. If the cards being read are light (many punches), the spring will be placed in one of the holes toward the rear of the plate. The spring is adjusted at the factory (as illustrated) for about 20-25% punch density or about 3 punches per column.
4. The four holes in the spring bracker may be termed the stacker tray preload adjustment. The spring should be placed in the bracket in a position which will allow sufficient clearance for the card to drop into the stacker tray and the tray then continue to load evenly and smoothly.

STACKER SHAFT SUPPORT - BEARING REPLACEMENT

1. Perform steps 1 and 2 of Replacement of Hopper Empty Switch Procedure.

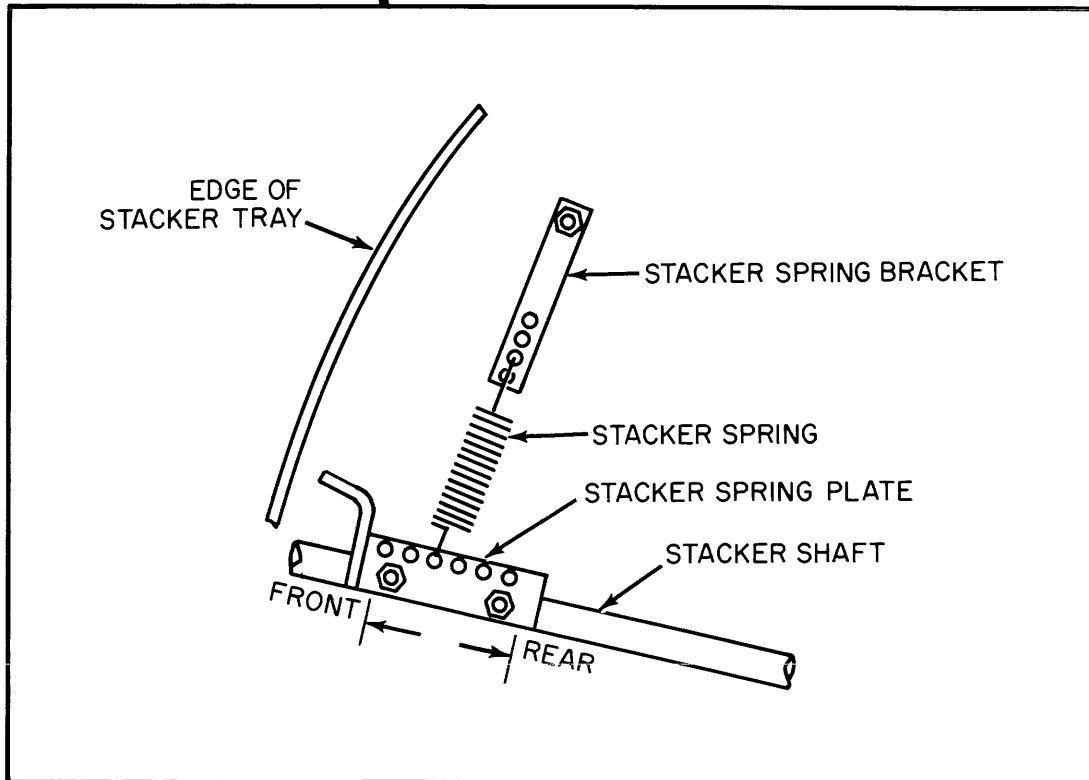
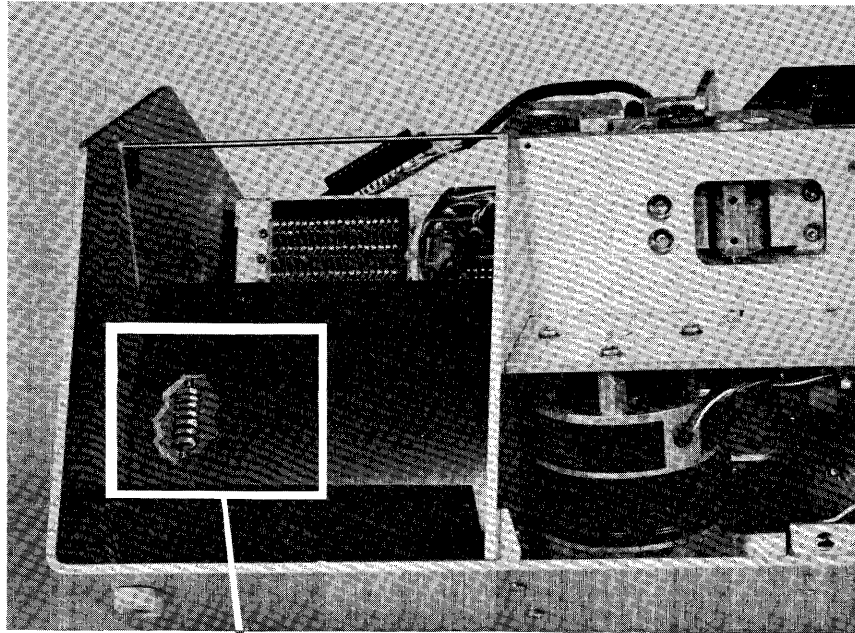

Figure 24. Partial Front View, Stacker Spring

2. LOOSEN eight DZUS fasteners (5) or remove six 6 x 32 button head screws holding rear panel, figure 2.
3. Disconnect fan motor connector and remove rear panel, figure 25.
4. Remove three 6 x 32 Phillips pan head screws (6) from bottom plate holding rear connector panel, figure 25.
5. Using a 5/16 Allen wrench, LOOSEN stacker shaft collar set screw, figure 26.
6. Remove two 8 x 32 pan head screws (7) from mainframe holding stacker shaft support casting, figure 26.
7. Move stacker shaft support casting to the rear and slide off shaft to the left.
8. Using an arbor press, remove and replace the two bearings in the stacker shaft support casting.
9. Reassemble in reverse order of disassembly making sure to replace collar on shaft when replacing casting.

REPLACEMENT OF BELT ON VACUUM PUMP MOTOR ASSEMBLY

1. Perform steps 1 through 4 of Stacker Shaft Support - Bearing Replacement.
2. Disconnect light station from power supply, figure 26.
3. Disconnect motor AC connector - located off cable on mainframe, figure 27.
4. Disconnect solenoid driver connector, figure 27.
5. Disconnect yellow lead from relay, figure 27.
6. Lift rubber protective cover from capacitor and remove red and blue leads from capacitor, figure 27.
7. Remove hopper empty switch leads, figure 22.
8. LOOSEN vacuum hose clamp screw and remove hose from main mounting plate, figure 27.
9. LOOSEN vacuum adapter clamp screw and lift adapter out of pump, figure 25.
10. Remove read head connector from card cage, figure 34.
11. Remove three 8 x 32 Phillips pan head screws (8), one from main mounting plate, and two from under mainframe, figure 28.
12. Remove two 8 x 32 flat head screws (9) from top of main mounting plate, figure 28.
13. Remove the main mounting plate and lay to one side.
14. Remove screw holding ground strap to subframe, figure 26.

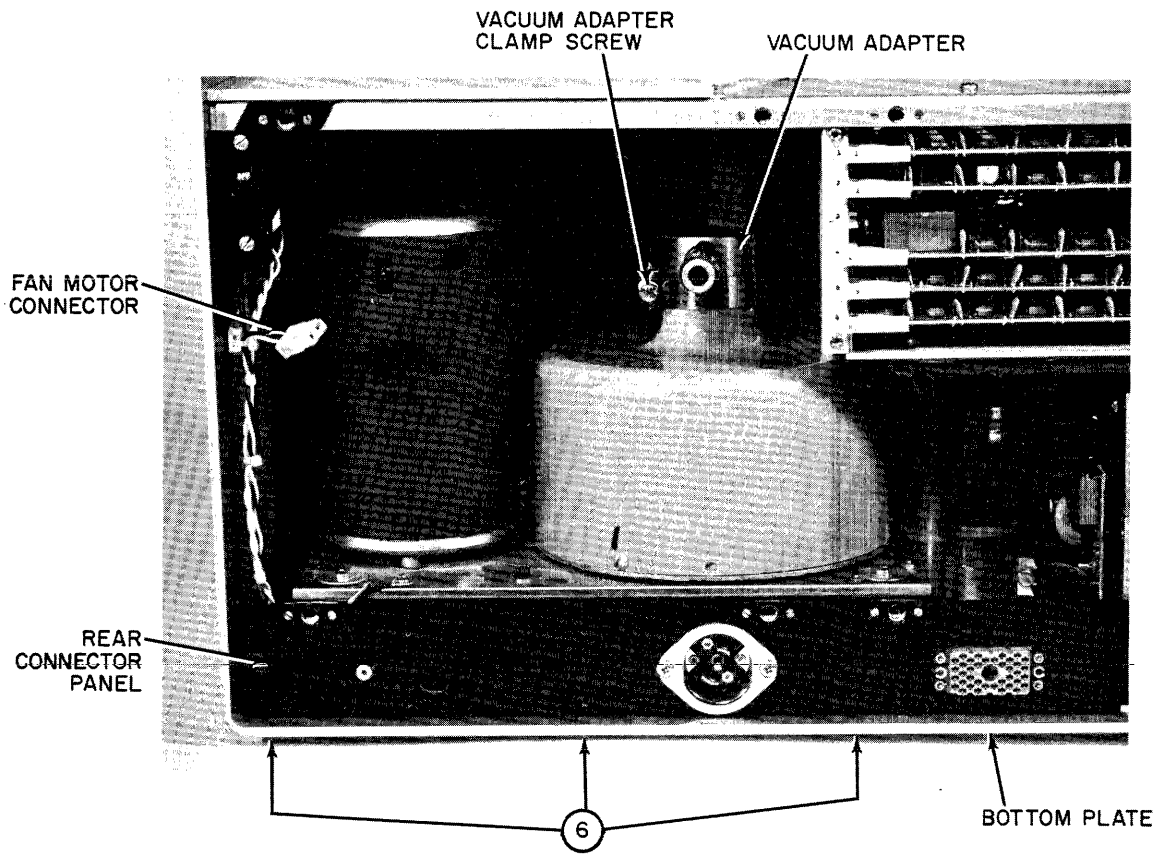

Figure 25. Rear View, Cover Removed

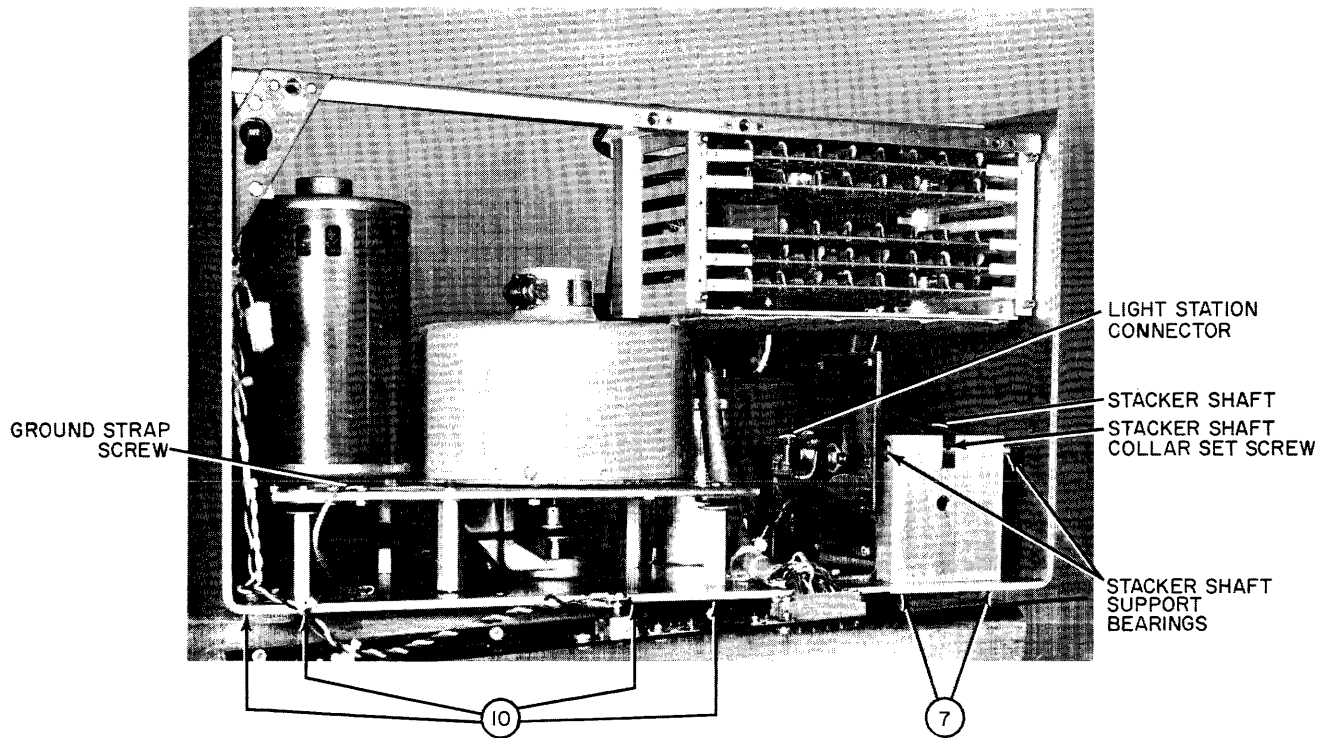

Figure 26. Rear View, Cover and Rear Connector Panel Removed

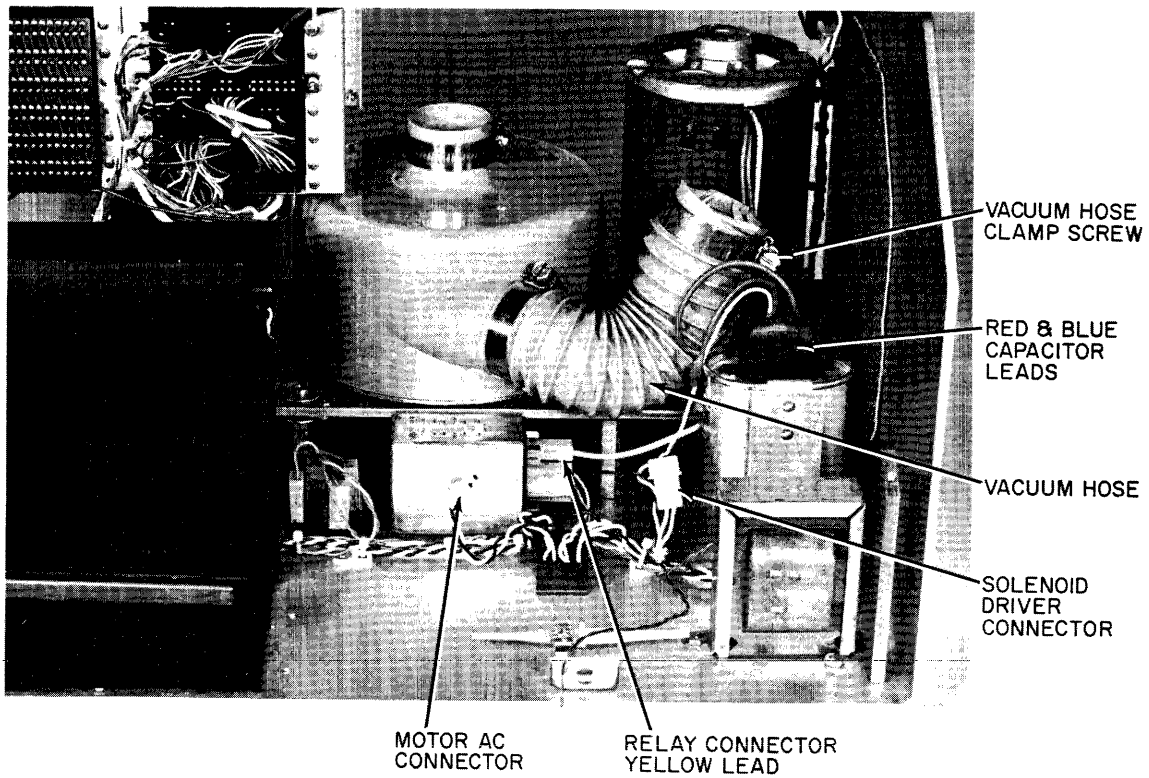

Figure 27. Front View, Main Wiring Connections

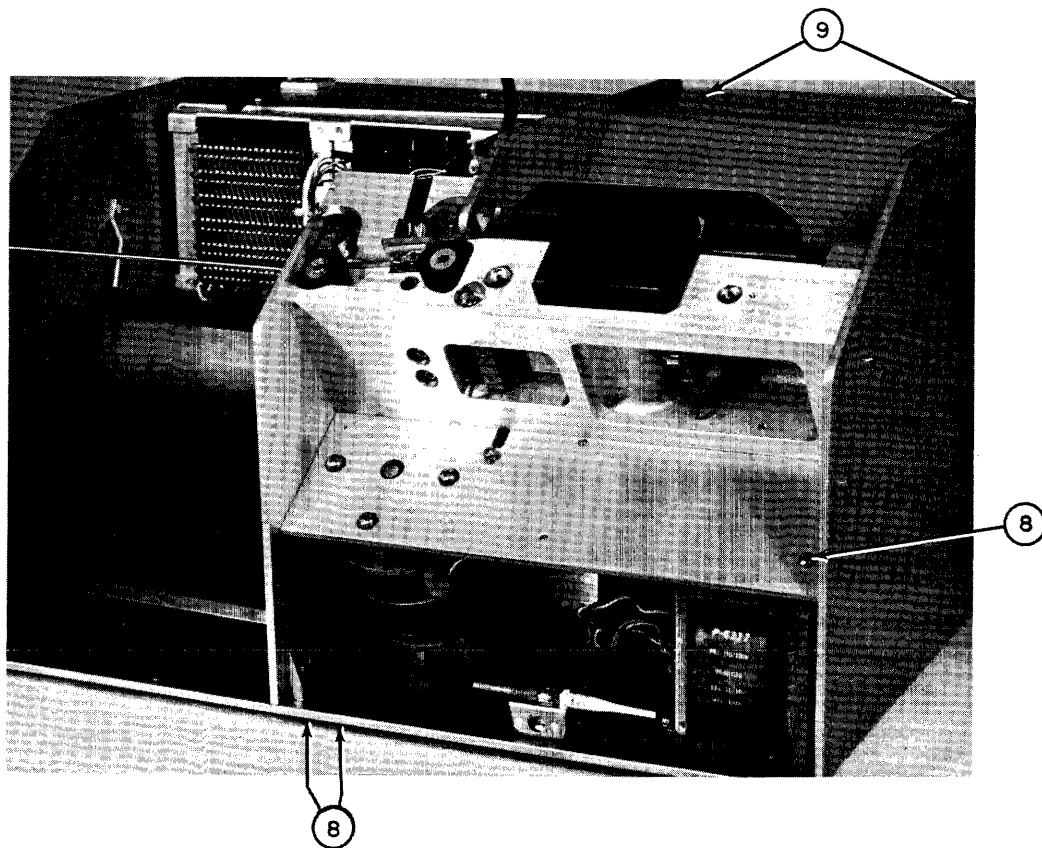

Figure 28. Front View, Main Mounting Plate Removal

15. Remove four Phillips head screws (10) located on underside of mainframe, figure 26.
16. The vacuum pump motor assembly may now be removed from the card reader.
17. LOOSEN the three hex bolts (11) holding the vacuum pump in place, figure 29.
18. Replace vacuum pump belt, figure 29.
19. Using a spring scale, adjust vacuum pump for a belt tension of 4-6 ounces. This is about 3/64" belt deflection, figure 29.
20. With the appropriate belt tension applied, tighten the three hex vacuum pump mounting bolts, figure 29.
21. Reinstall the vacuum pump assembly into the card reader in reverse order of disassembly.

REPLACEMENT OF MAIN DRIVE MOTOR BELT

1. It is necessary to remove the main mounting plate for this repair. Perform steps 1 through 13 of Replacement of Belt on Vacuum Pump Motor Assembly.
2. Using a Phillips screwdriver, remove three main drive motor mounting screws (4), figure 22. If the belt was not broken, there should now be sufficient slack to slip the belt over the motor pulley and remove the motor.
3. Using a 5/64 Allen wrench, LOOSEN one 8 x 32 set screw in timing disk, figure 30.

CAUTION

REMOVE TIMING DISK USING EXTREME CARE
NOT TO DAMAGE THE TEETH ON DISK. WRAP
DISK IN SOFT TISSUE WHILE NOT IN THE READER.

4. Replace the main drive motor belt over the timing disk pulley and the roller pulley and motor shaft pulley in that order.
5. Replace the belt over the motor shaft pulley, replace the motor in its mounting position, and then replace the motor mounting screws but DO NOT tighten.
6. Perform steps 3 through 5 of Adjustment of Tension on Main Drive Motor Belt.
7. Replace timing disk on shaft and line up teeth on timing disk with tip on magnetic pickup. Using a feeler gauge, check for .007 to .008 clearance

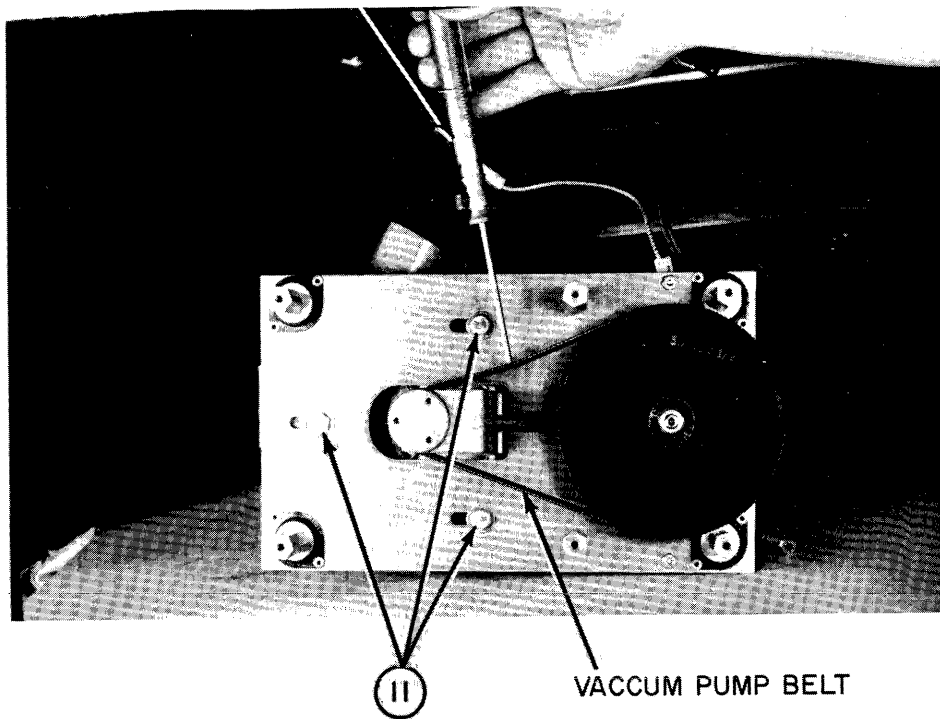

Figure 29. Vacuum Pump Belt Adjustment

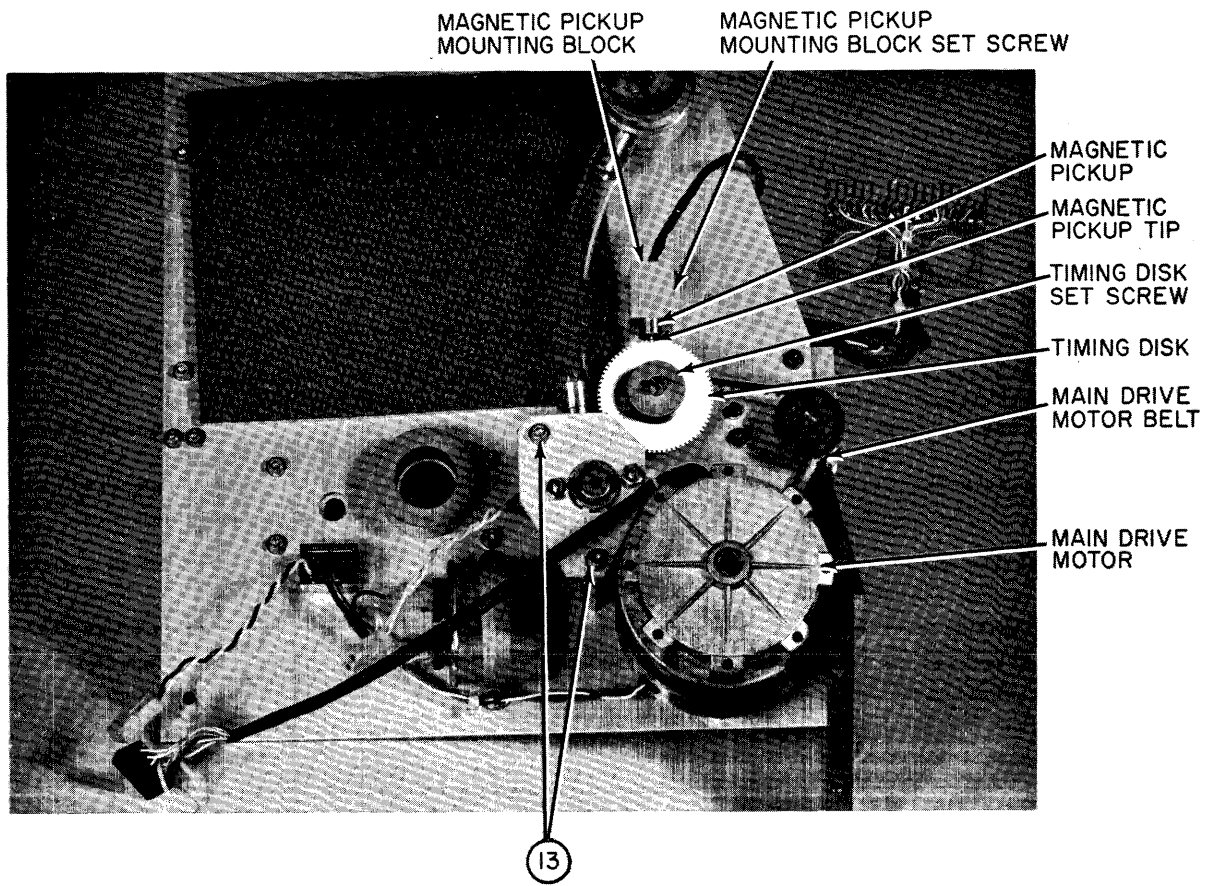

Figure 30. Bottom View, Main Mounting Plate

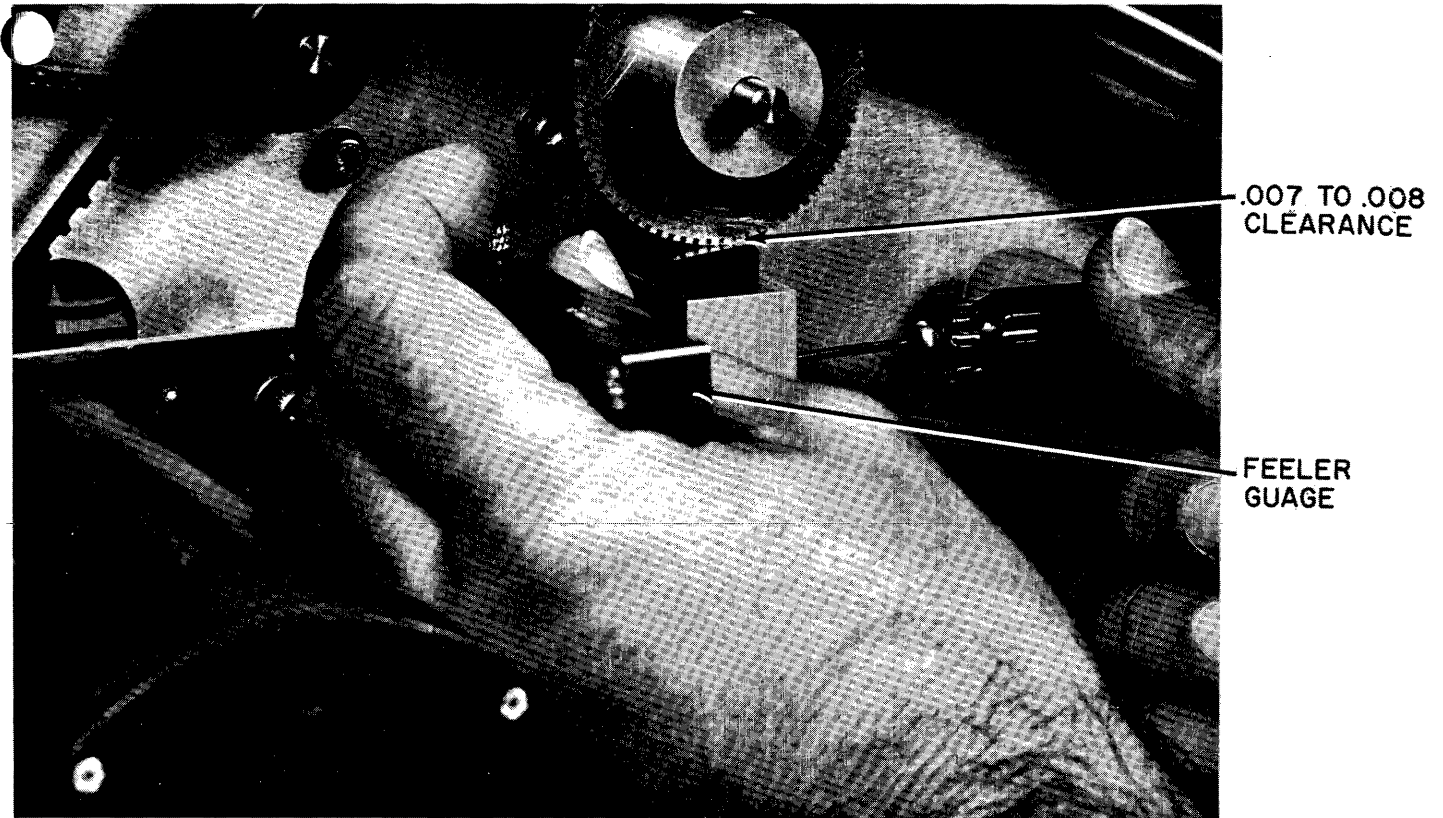

Figure 31. Timing Disc Air-gap Adjustment

between timing disk teeth and magnetic pickup tip. If out of clearance, perform step 8 of Replacement and Adjustment of Magnetic Pickup, figure 31.

NOTE

Before tightening timing disk set screw, check to make sure timing disk teeth are precisely in a horizontal plane with the magnetic pickup tip.

8. Reassemble card reader in reverse order of disassembly.

REPLACEMENT AND ADJUSTMENT OF MAGNETIC PICKUP

1. It is necessary to remove the main mounting plate for this repair. Perform steps 1 through 13 of Replacement of Belt on Vacuum Pump Motor Assembly.
2. Using a 1/16 Allen wrench, LOOSEN set screw in magnetic pickup mounting block, figure 30.
3. Remove magnetic pickup from mounting block, figure 30.
4. Unwrap the read head connector cable to free the magnetic pickup cable.
5. Unsolder wires from pins J, K and L on the read head connector, figure 34.
6. Solder the new magnetic pickup wires to the read head connector and rewrap the read head connector cable.
7. Insert the new pickup unit into the mounting block.
8. Using a feeler gauge, adjust spacing between timing disk teeth and tip of pickup unit for .007 to .008, figure 31.
9. Reassemble card reader in reverse order of disassembly.

REPLACEMENT OF SOLENOID

1. It will be necessary to remove the main mounting plate for this repair. Perform steps 1 through 13 of Replacement of Belt on Vacuum Pump Motor Assembly.
2. Remove solenoid spring from spring post and arm stud, figures 32 and 33.
3. Using a .050 or 1/16 Allen wrench, LOOSEN two set screws in the top solenoid coupling, figure 33.
4. Using a 9/64 Allen wrench, remove two 8 x 32 socket head screws (13) holding solenoid mounting plate, figure 33. Remove solenoid.

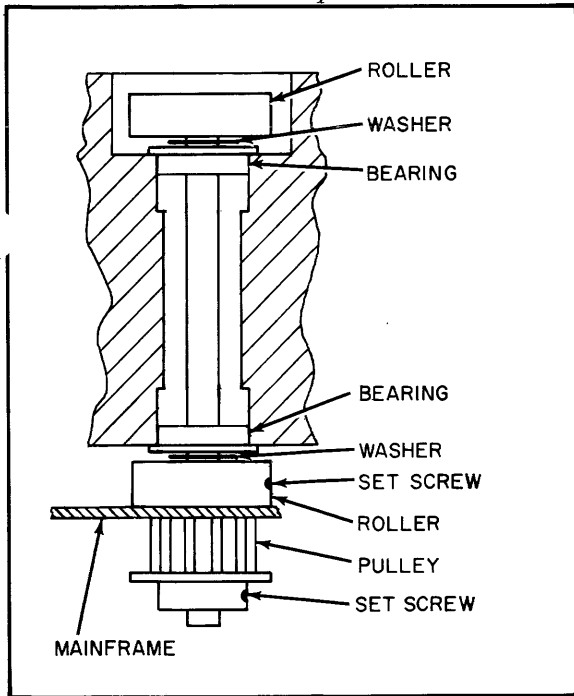
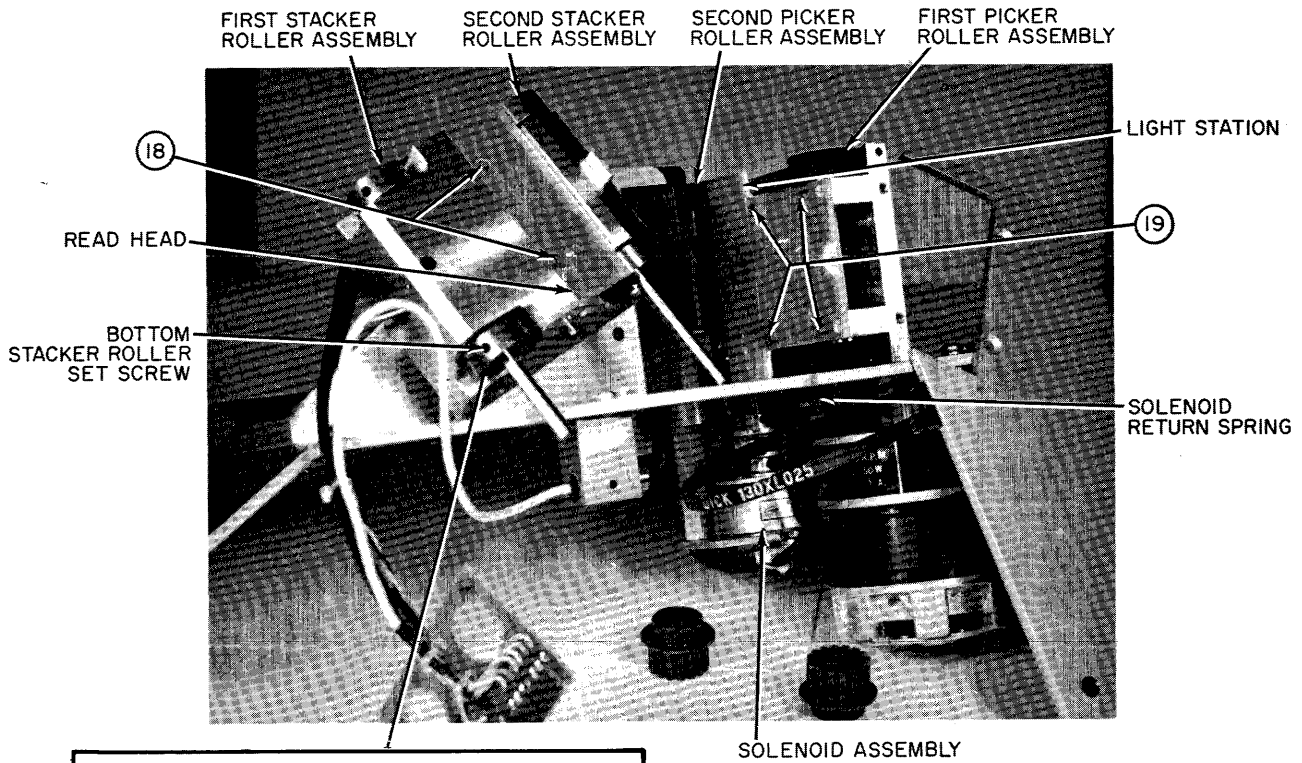

Figure 32. Stacker Casting Removal and Bearing Replacement

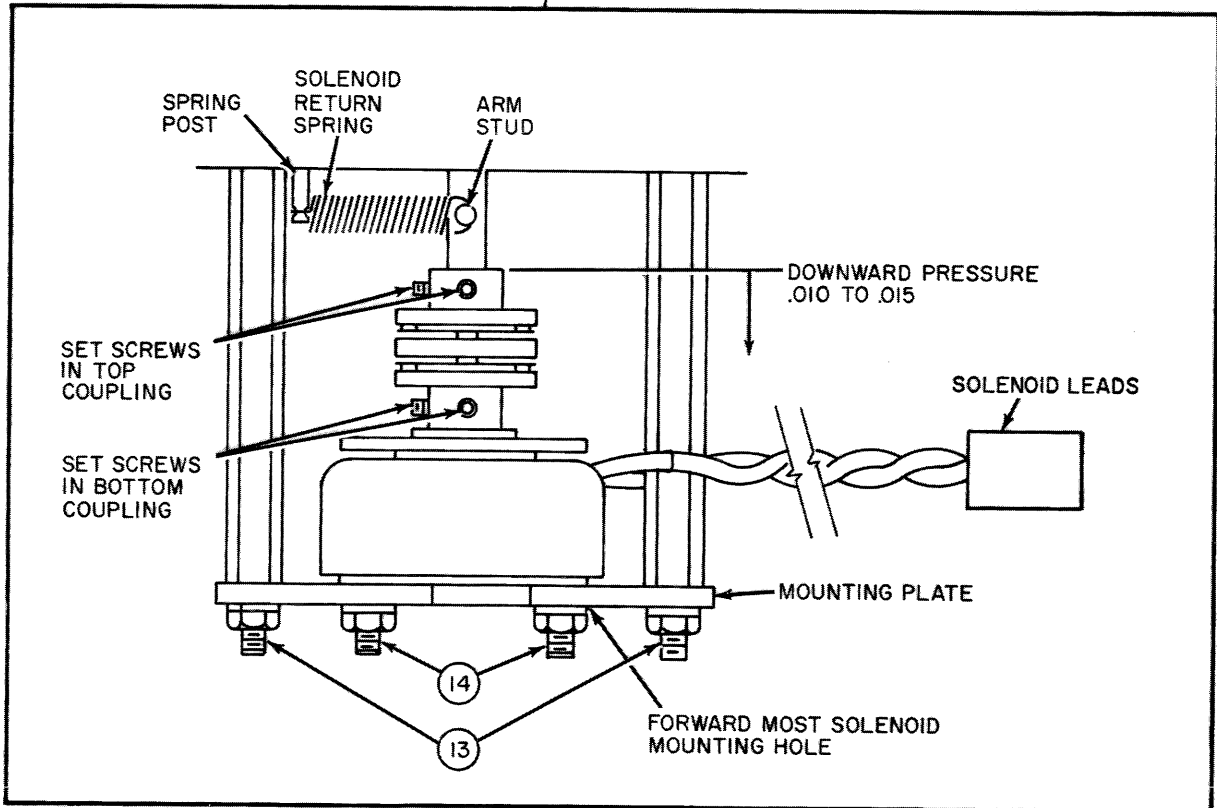
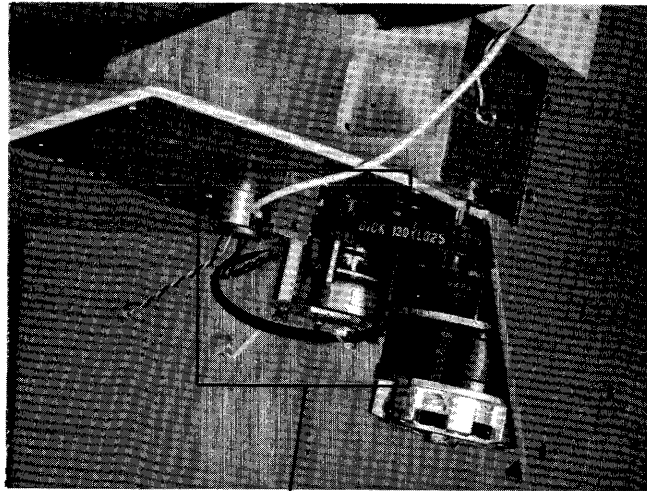

Figure 33. Solenoid Replacement and Adjustment

5. Using an 11/32 hex wrench, remove two 8 x 32 mounting nuts (14) , figure 33.

6. Using a .050 or 1/16 Allen wrench, LOOSEN two set screws retaining the coupling on the solenoid shaft. Remove coupling, figure 33.

NOTE

Remove the set screws from the coupling and replace using LOCKTITE GRADE C. All operational and mounting hardware, with the exception of panel screws, should be replaced using LOCKTITE GRADE C.

7. Replace the coupling locating the bottom coupling set screws on the two flat sides of the shaft, figure 33.

8. Tighten the bottom coupling set screws and replace the solenoid on the mounting plate making sure holes are in the proper position, with wires extending from the LEFT side, as viewed from the bottom of the main mounting plate.

9. Replace solenoid on mounting posts.

10. Replace the solenoid return spring between the spring post and the arm stud, figure 33.

11. Preload the solenoid coupling by pressing downward .010 to .015 and tighten the top coupling set screws, figure 33.

NOTE

The solenoid will turn as the set screws are tightened to the flat sides of the shaft. This is a natural built in alignment. This alignment prevents the solenoid from bottoming-out during operation.

12. Reassemble reader in reverse order of disassembly.

REPLACEMENT OF ROLLER BEARINGS, READ HEAD OR LIGHT STATION

NOTE

Use the following ten procedures to remove the stacker casting. This casting must be removed to accomplish any of the above three repairs.

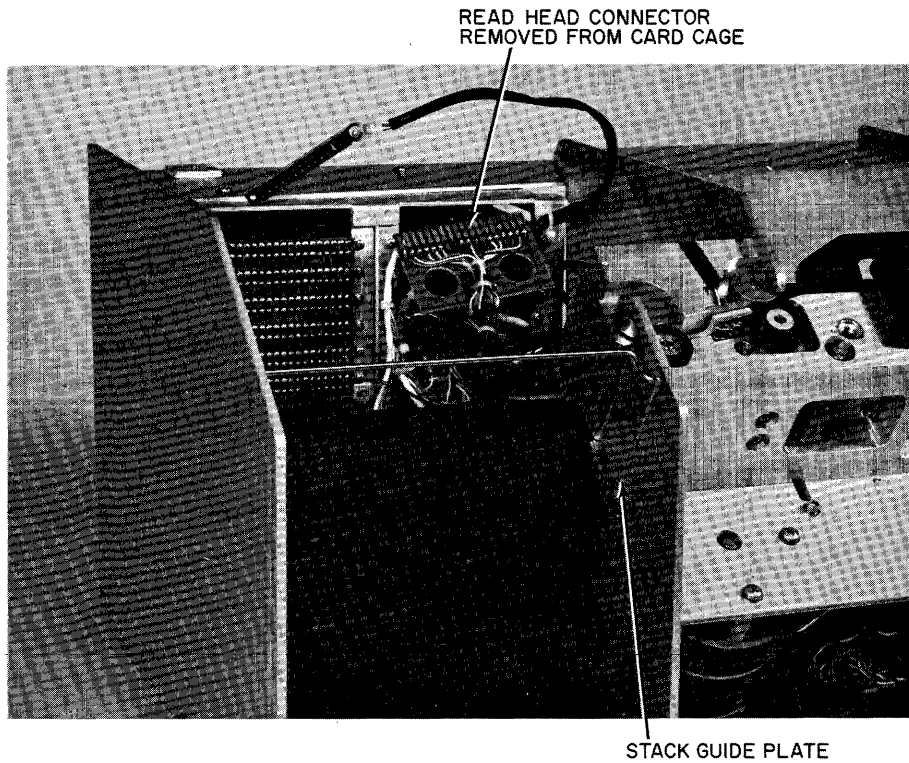

Figure 34. Top View Casting Assemblies

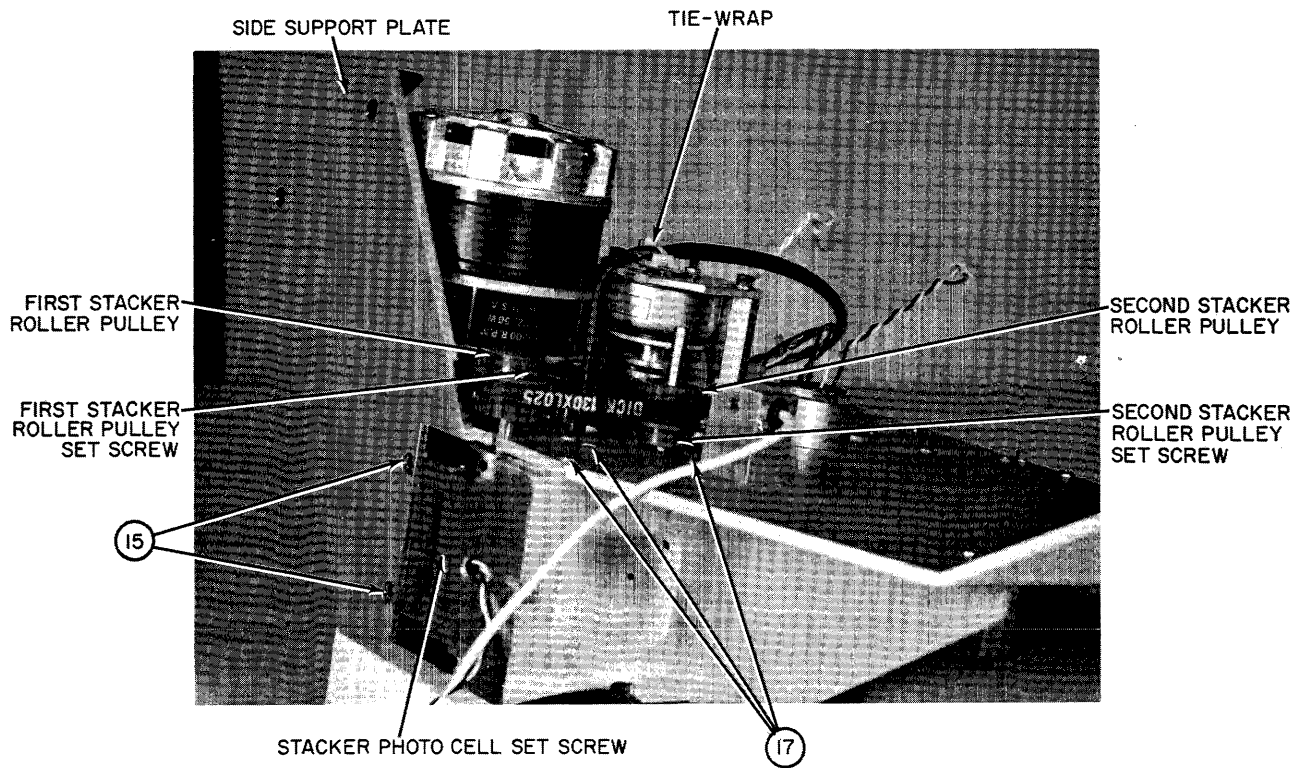

Figure 35. Bottom View Main Drive Motor Assembly

1. It will be necessary to remove the main mounting plate for these repairs. Perform steps 1 through 13 of Replacement of Belt on Vacuum Pump Motor Assembly.

2. Using a flat blade knife, remove stack guide plate, figure 34.

3. Remove two 8 x 32 Phillips flat head screws (15) holding side support plate, figure 35.

4. Remove two 8 x 32 Phillips screws (16) from input hopper wall, figure 23.

5. LOOSEN three Phillips screws (4) holding main drive motor, figure 22.

6. Using a 5/64 Allen wrench, LOOSEN set screw in timing disk. Remove timing disk, figure 30.

7. Remove main drive motor belt, figure 30.

8. Using a 3/32 Allen wrench, LOOSEN the set screws in the two stacker nylon pulleys, figure 35. Remove pulleys.

9. Cut nylon tie-wrap on solenoid mounting plate, holding light station cable, figure 35.

10. Using a 9/64 Allen wrench, remove three 8 x 32 socket head screws (17) holding stacker casting, figure 35. Lay stacker casting to one side.

TO REPLACE ROLLER ASSEMBLY BEARINGS

1. Using a 1/16 Allen wrench, LOOSEN the set screw in the bottom roller of the assembly to be removed. Remove roller, figure 32.

NOTE

The second picker roller has a split shaft. LOOSEN the set screw in the top or bottom roller. The shaft of either may then be removed from the center of the casting, figure 32.

2. Remove bottom bearing spacer washer from shaft, figure 32.

3. Lift shaft straight up out of casting. Note there is another spacer washer between the top roller and the bearing seat, figure 32.

4. Using a knife blade, pry out top or bottom bearing to be replaced.

NOTE

The bearings are a loose pressfit into the casting. If the bearings appear difficult to remove, use a slender tool such as a small Allen screwdriver and tap the EDGE of the bearing from the inside of the shaft hole.

5. Reassemble in reverse order of disassembly, making sure spacer washers are installed between top and bottom rollers and bearing seats.
6. Apply firm finger pressure between the top and bottom rollers and tighten set screw in the bottom roller. Check that there is NO VERTICAL PLAY in the shaft after tightening the roller set screws.
7. When replacing the nylon pulleys, make sure set screw is on the flat side of the shaft, and that the pulley flange is oriented correctly, figure 35.

CAUTION

USING MODERATE TORQUE, TIGHTEN PULLEY SET SCREWS.
DO NOT OVERTORQUE OR DAMAGE WILL RESULT TO PULLEY.

8. Re-install stacker casting onto main mounting plate. To insure pressure between the stacker and picker rollers, squeeze the stacker casting and picker casting together with hand pressure when tightening the three 8 x 32 socket head screws (17) holding the stacker casting, Figure 35. After tightening, check pinch between rollers. The steel roller should cause a slight depression onto the rubber rollers.
9. Perform step 8 of Replacement and Adjustment of Magnetic Pickup, page 52.
10. Perform step 21, page 61, of Replacement of Picker.

TO REPLACE READ HEAD

1. Remove two 4-40 x $\frac{1}{4}$ flat head Phillips screws (18) to remove read head, figure 32.
2. Install new read head and replace read head connector in card cage when installing main mounting plate, figure 34.

TO REPLACE LIGHT STATION

1. Remove four 2-56 x $\frac{1}{4}$ flat head Phillips screws (19) to remove light station, figure 32.
2. Remove nylon tie-wrap from solenoid mounting plate, figure 35.
3. Install new light station and replace tie-wrap on solenoid mounting plate.

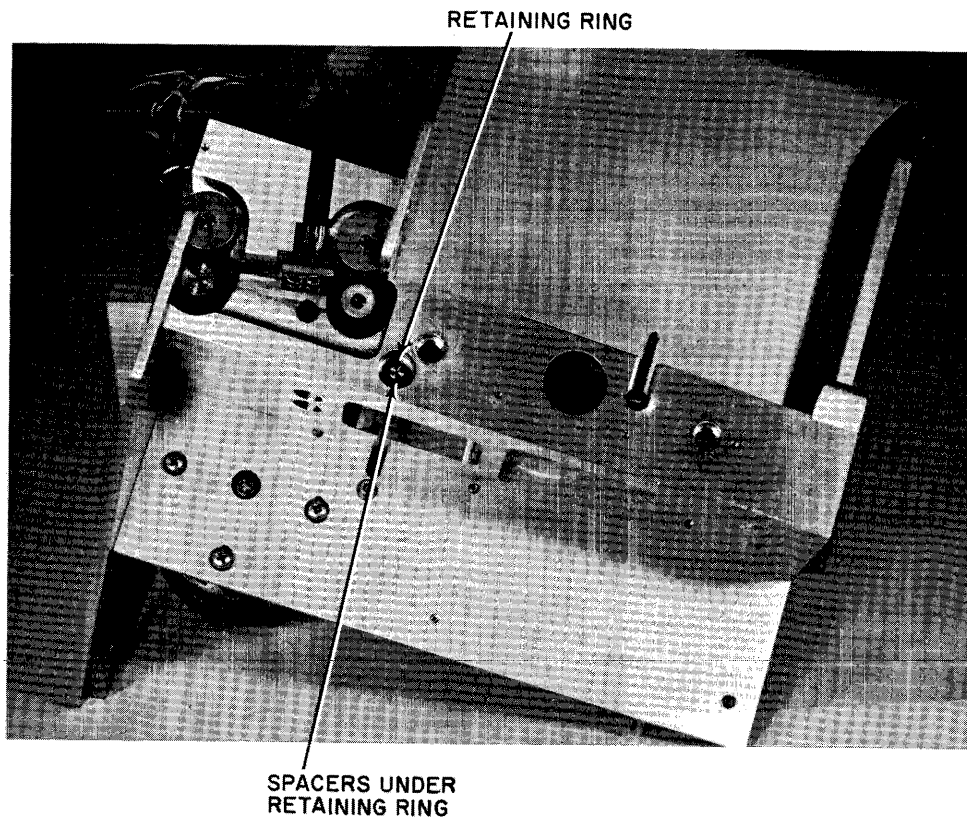

Figure 36. Top View Stacker Casting Assembly

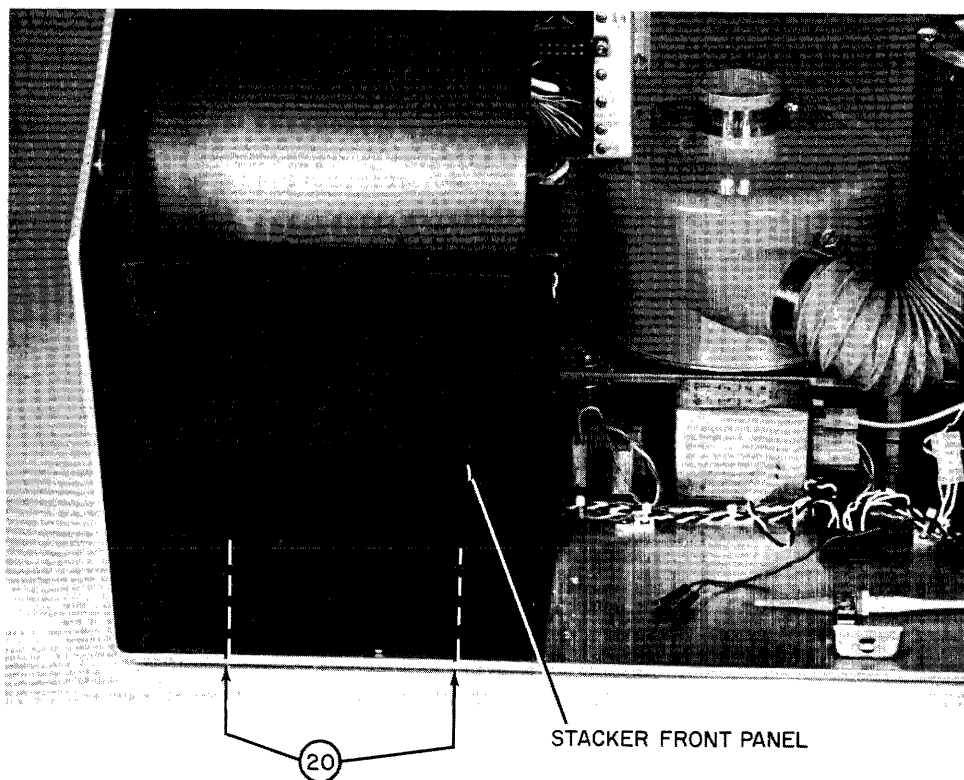

Figure 37. Stacker Panel Removal

4. Reinstall stacker casting onto main mounting plate in reverse order of disassembly.

5. Plug light station connector into power supply when installing main mounting plate, figure 26.

REPLACEMENT OF PICKER

1. It is necessary to remove the main mounting plate for this repair. Perform steps 1 through 13 of Replacement of Belt on Vacuum Pump Motor Assembly.

2. Remove solenoid return spring from spring post and arm stud, figure 33.

3. Using a .050 or 1/16 Allen wrench, LOOSEN two set screws in the top solenoid coupling, figure 33.

4. Using a 9/64 Allen wrench, remove two 8 x 32 socket head screws (13) holding solenoid mounting plate, figure 33.

5. Remove solenoid assembly.

6. Using a #2 retaining ring remover tool, remove the retaining ring from the top of the picker shaft, figure 36.

7. Remove spacers located under the retaining ring, figure 36.

CAUTION

ALL OF THE SPACERS MUST BE REPLACED
IN REASSEMBLY.

8. Using a 5/64 Allen wrench, LOOSEN two set screws holding picker sector, figure 22.

9. Remove picker shaft from bottom of main mounting plate.

10. Using a Phillips screwdriver, remove throat block, figure 23.

11. Remove picker sector from rear side of picker casting, figure 23.

12. Replace picker sector, shaft, spacers and retaining ring.

13. Adjust shaft to place sector set screws on flat side of shaft.

14. Using a 6" metal ruler, measure 1.625" from the main mounting frame up to the center row of holes on the picker sector, figure 23.

15. Retaining this measurement, tighten the two picker sector set screws, figure 22.

16. Using a .050 Allen wrench, LOOSEN the pick vacuum set screw, figure 23.

17. Using a feeler gauge, adjust clearance between pick vacuum tube plate and picker sector for .002 or .003. Tighten pick vacuum set screw, figure 23.

18. Check sector travel using procedure for adjustment of Picker Sector travel.

19. Replace solenoid and adjust top solenoid coupling using step 11 of Replacement of Solenoid. Replace return spring, figure 33.

20. Replace throat block but do not tighten set screw, figure 23.

21. Using a feeler gauge, adjust pick throat for a clearance of .007 to .008 between throat block and picker sector and tighten screw, figure 23.

22. Reassemble reader in reverse order of disassembly.

REPLACEMENT OF STACKER FULL SWITCH

1. Perform steps 1 and 2 of Replacement of Hopper Empty Switch.

2. Remove two 6 x 32 Phillips screws (20) from bottom of mainframe holding stacker front panel, figure 37.

3. Remove wires from switch, remove and replace switch, figure 38.

4. Check to make sure switch is mechanically activated when stacker tray is almost full.

5. Reassemble reader in reverse order of disassembly.

REPLACEMENT OF STACKER PHOTOCELL

1. Perform steps 1 and 2 of Replacement of Hopper Empty Switch.

2. Using a 1/16 Allen screwdriver, LOOSEN set screw in stacker casting holding stacker photocell, figure 35.

3. Remove photocell from casting, figure 35, and tag black and white wires from photocell.

4. Replace photocell, align photocell flush with stacker casting face-plate, and tighten photocell set screw, figure 35. Replace leads.

5. Reassemble reader in reverse order of disassembly.

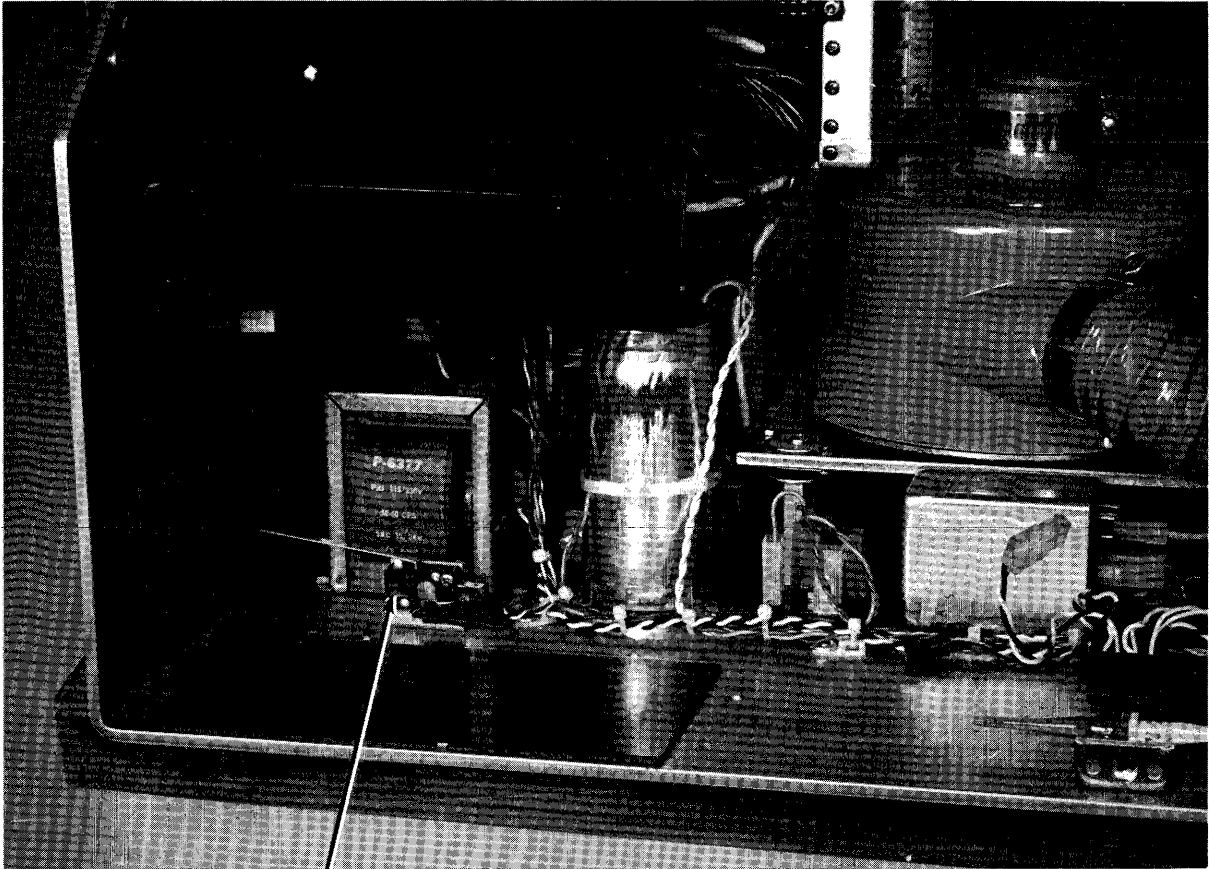

STACKER FULL SWITCH

Figure 38. Stacker Full Switch Replacement

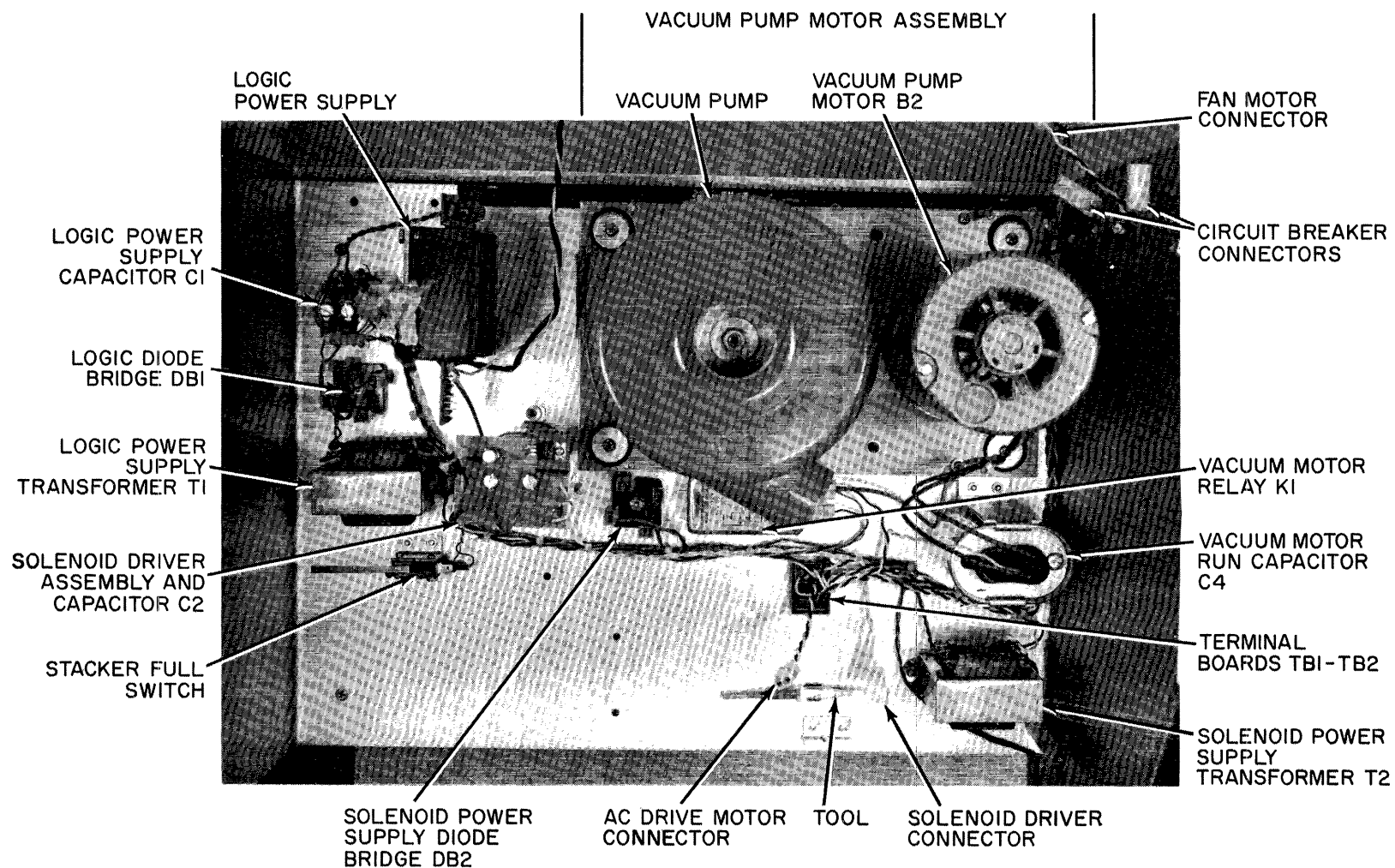

Figure 39. Main Frame Component Location

APPENDIX A

ELECTRICAL DRAWINGS

The electrical drawings included as part of this manual represent the standard Documentation card reader. If special electrical drawings are required, they will be included as reduced blueprints and will supersede the standard drawings.

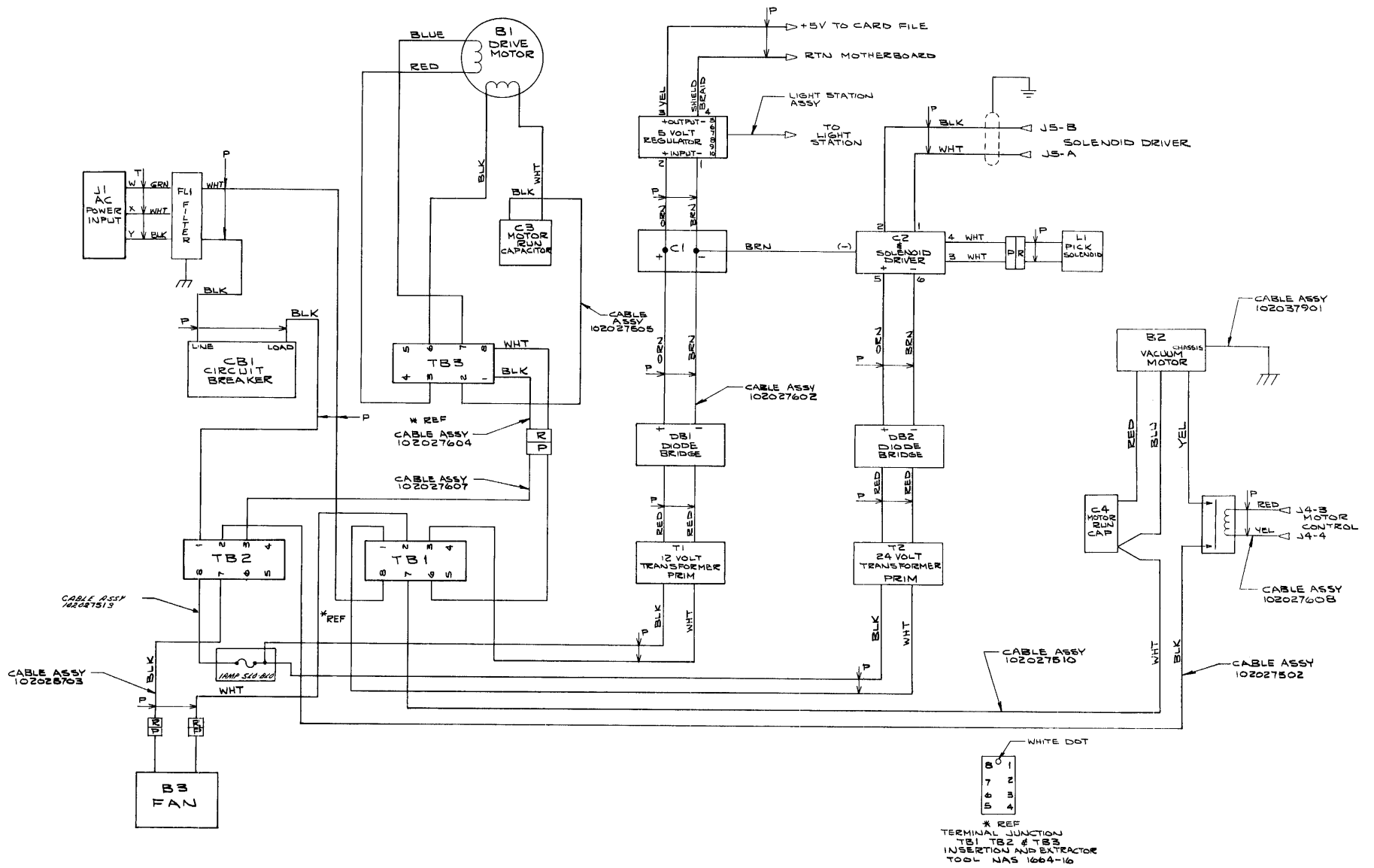
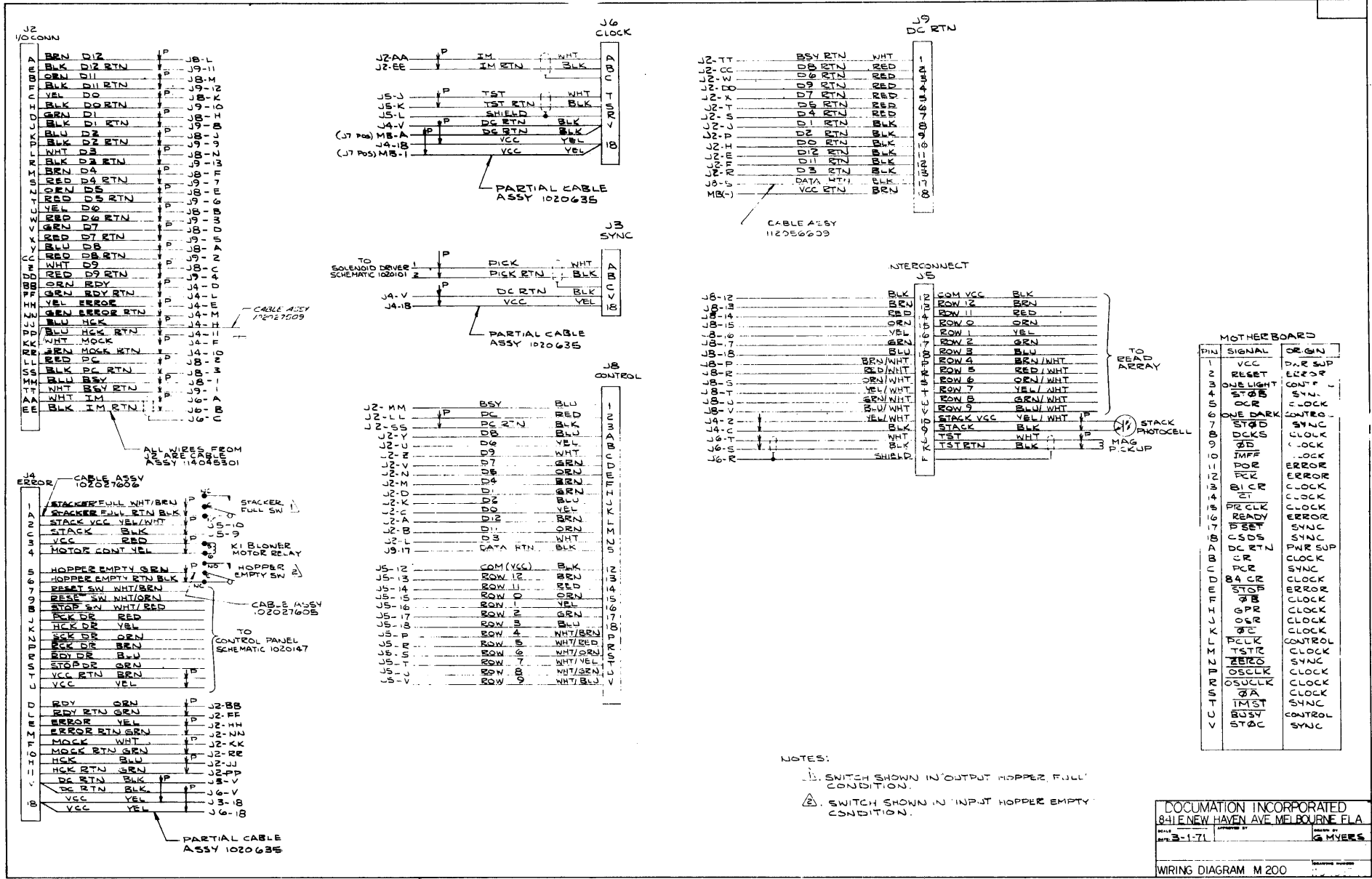

Figure A1. Wiring Diagram (Sheet 1 of 2)
Dwg. No. 1140755A



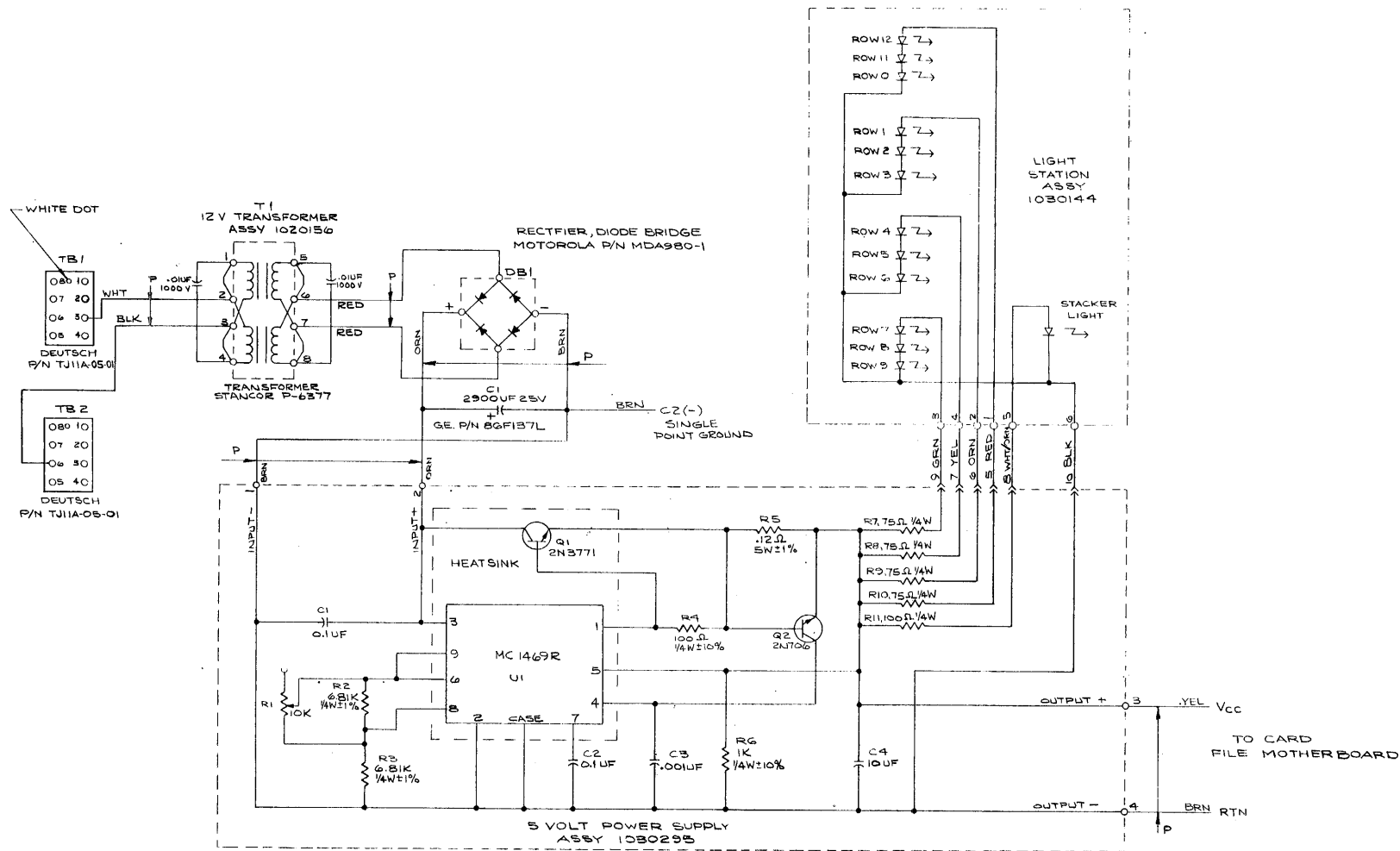
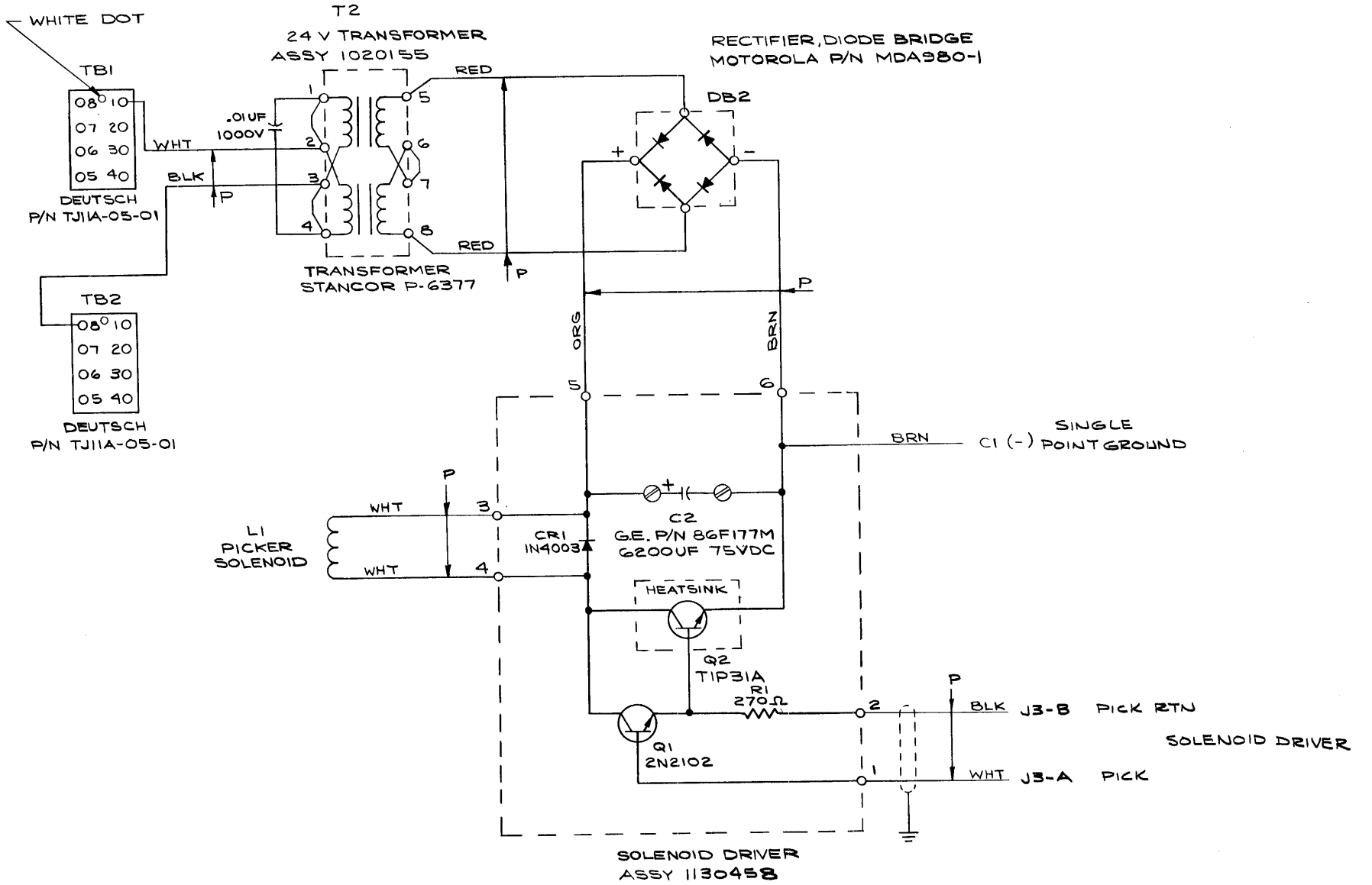
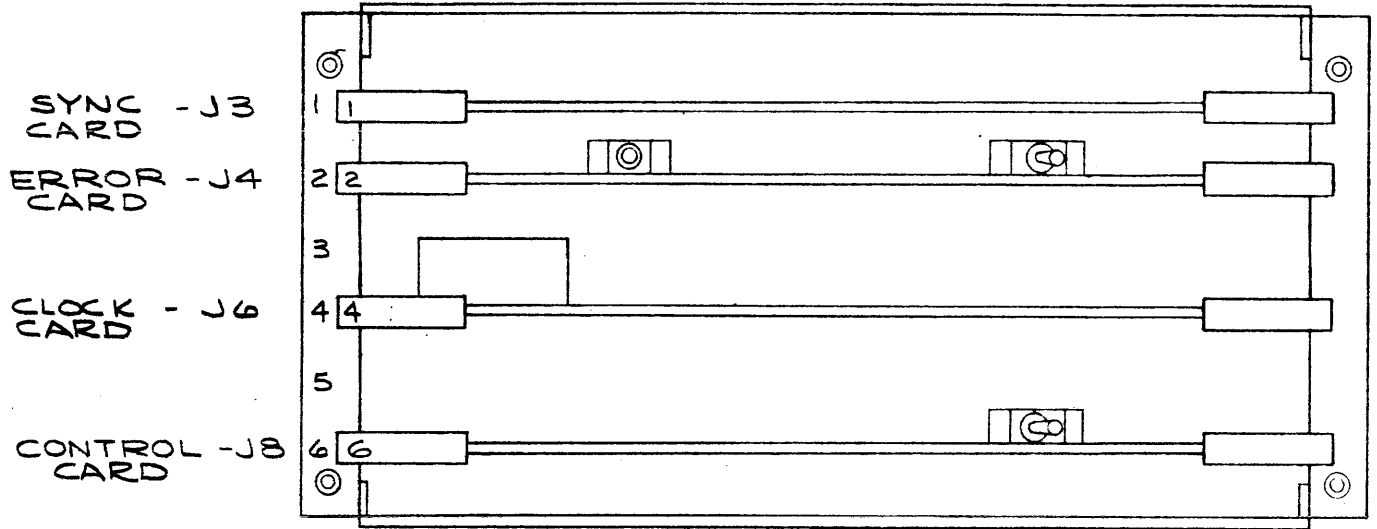

Figure A2. 5 Volt Power Supply
Dwg. No. 1140637



A4

Figure A3. Solenoid Driver
Dwg. No. 1140632



CARD FILE , REAR VIEW
COVER REMOVED

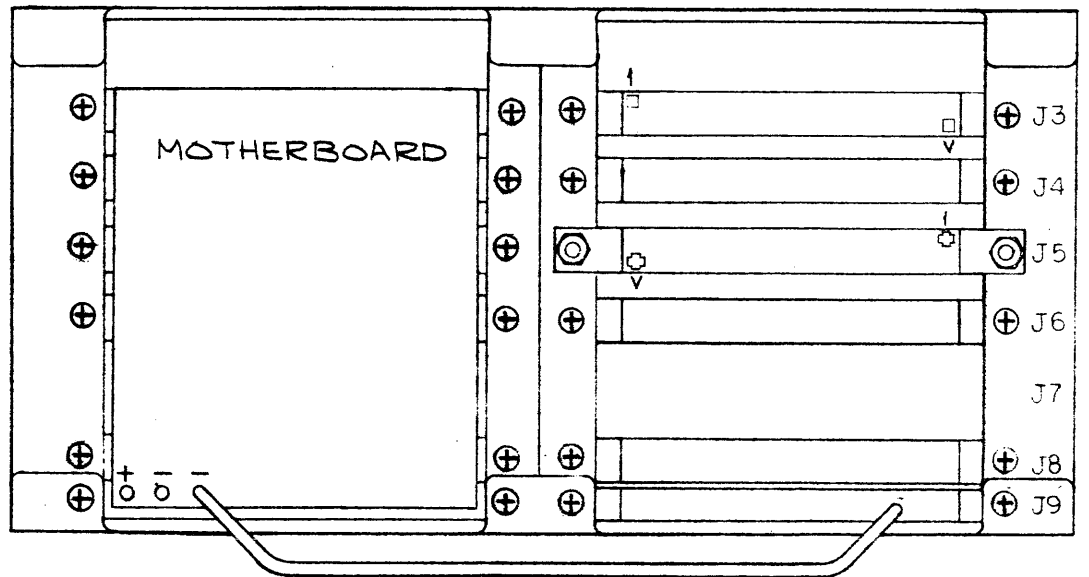

CONNECTOR VIEW

Figure A4. Card File

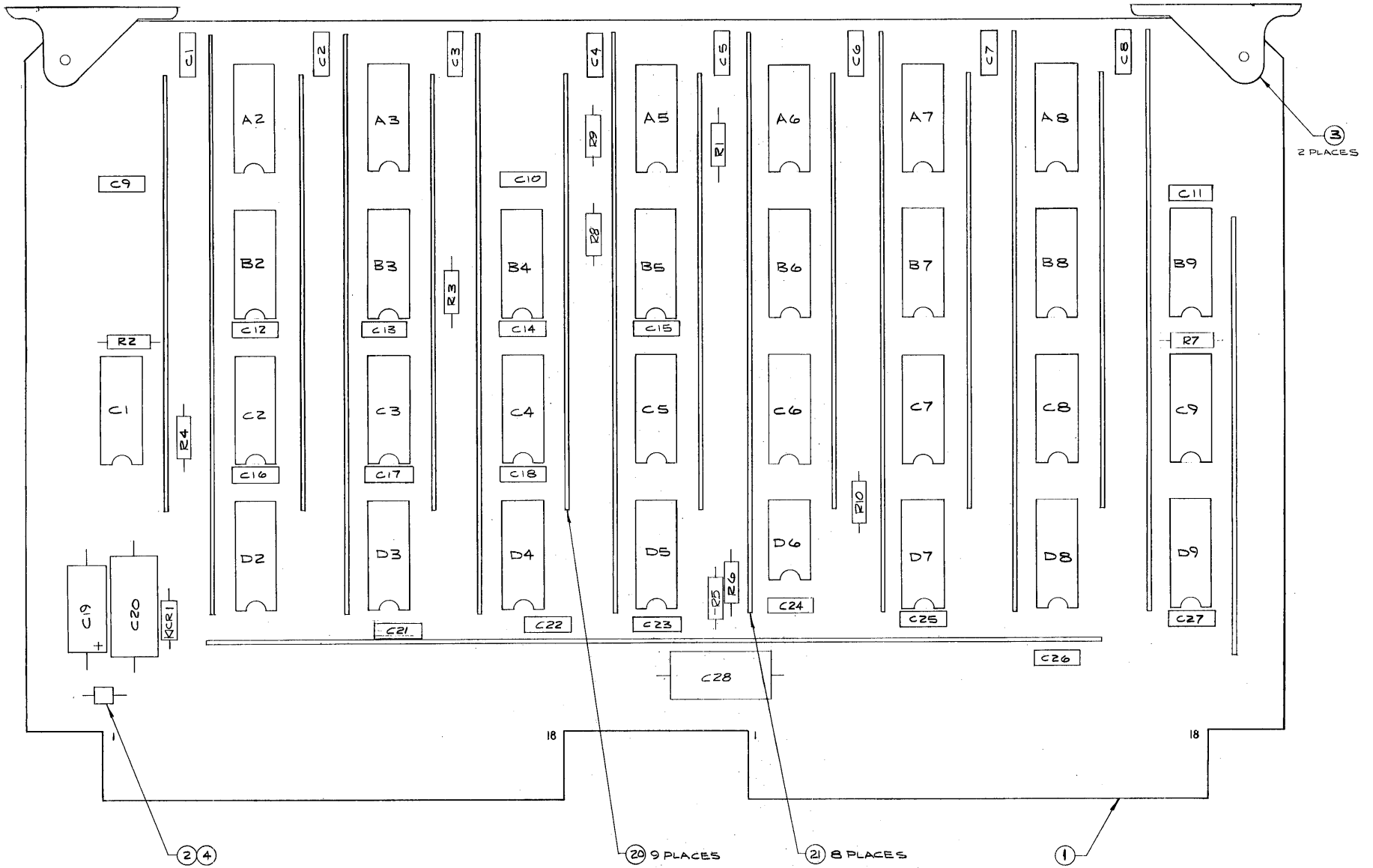

Figure A5. Sync Card Assembly
Dwg. No. 1040353E

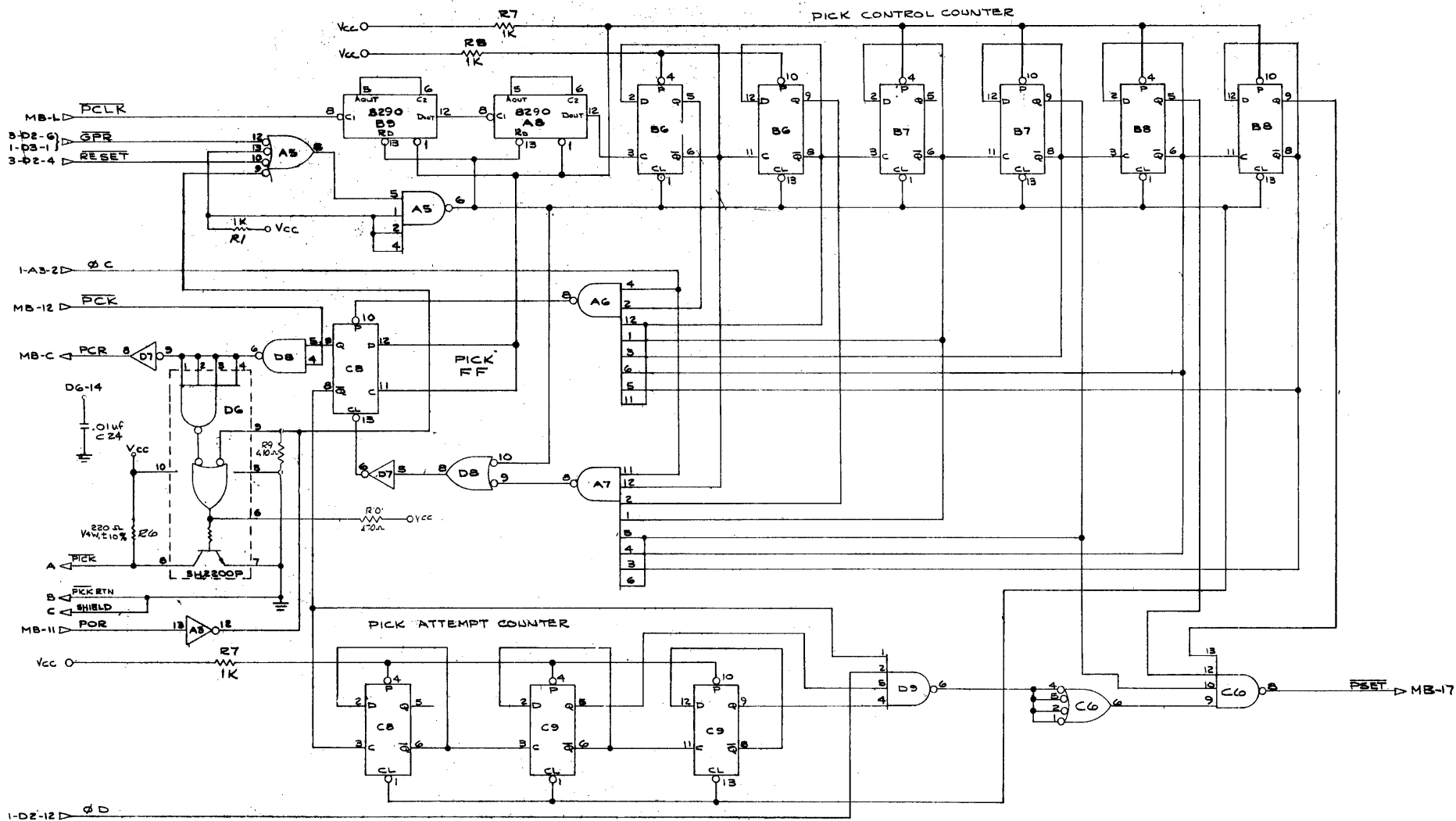

Figure A6. (Sheet 2 of 3)

A8

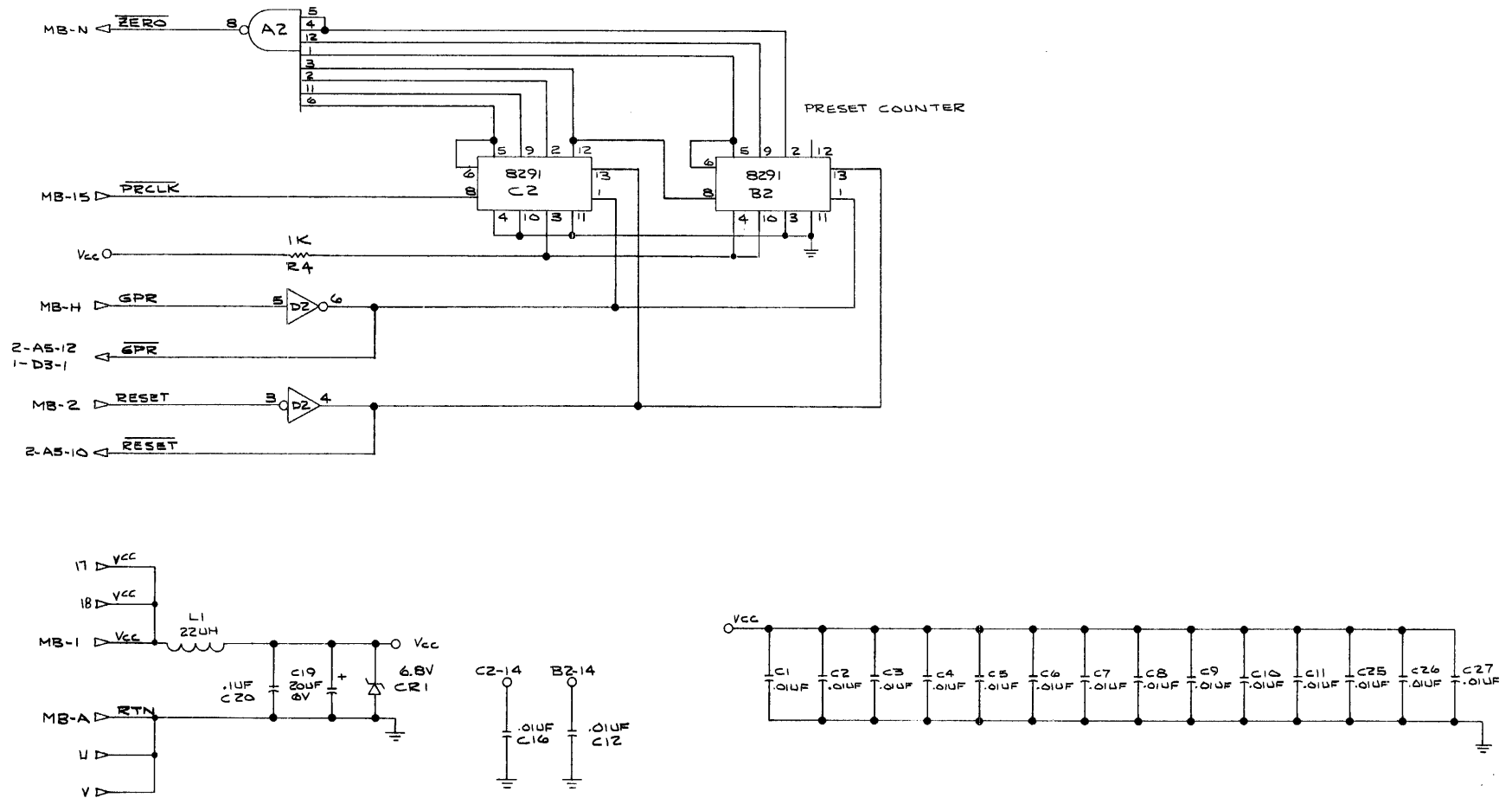

Figure A6. (Sheet 3 of 3)

A10

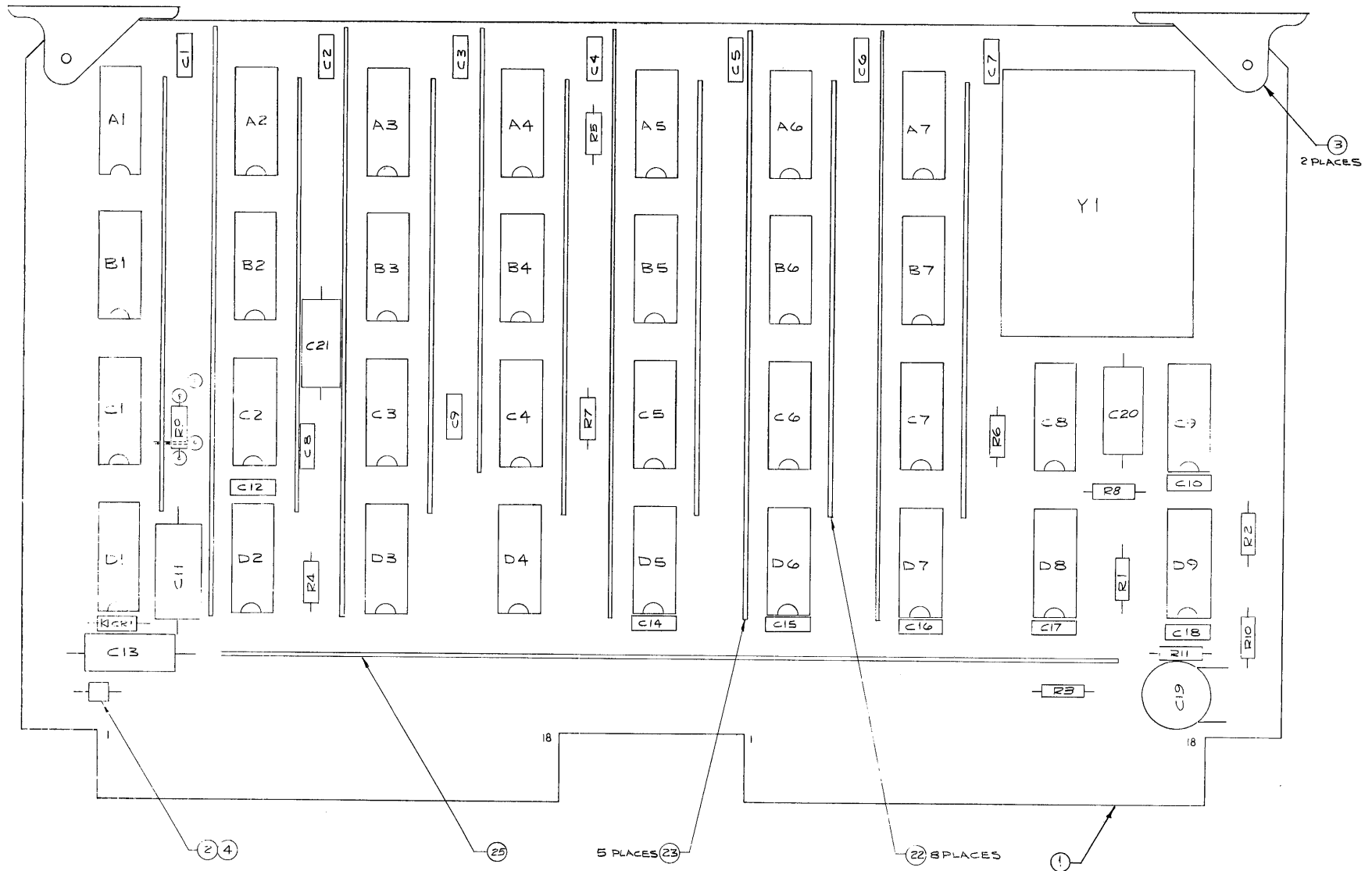

Figure A7. Clock Card Assembly
Dwg. No. 1040765

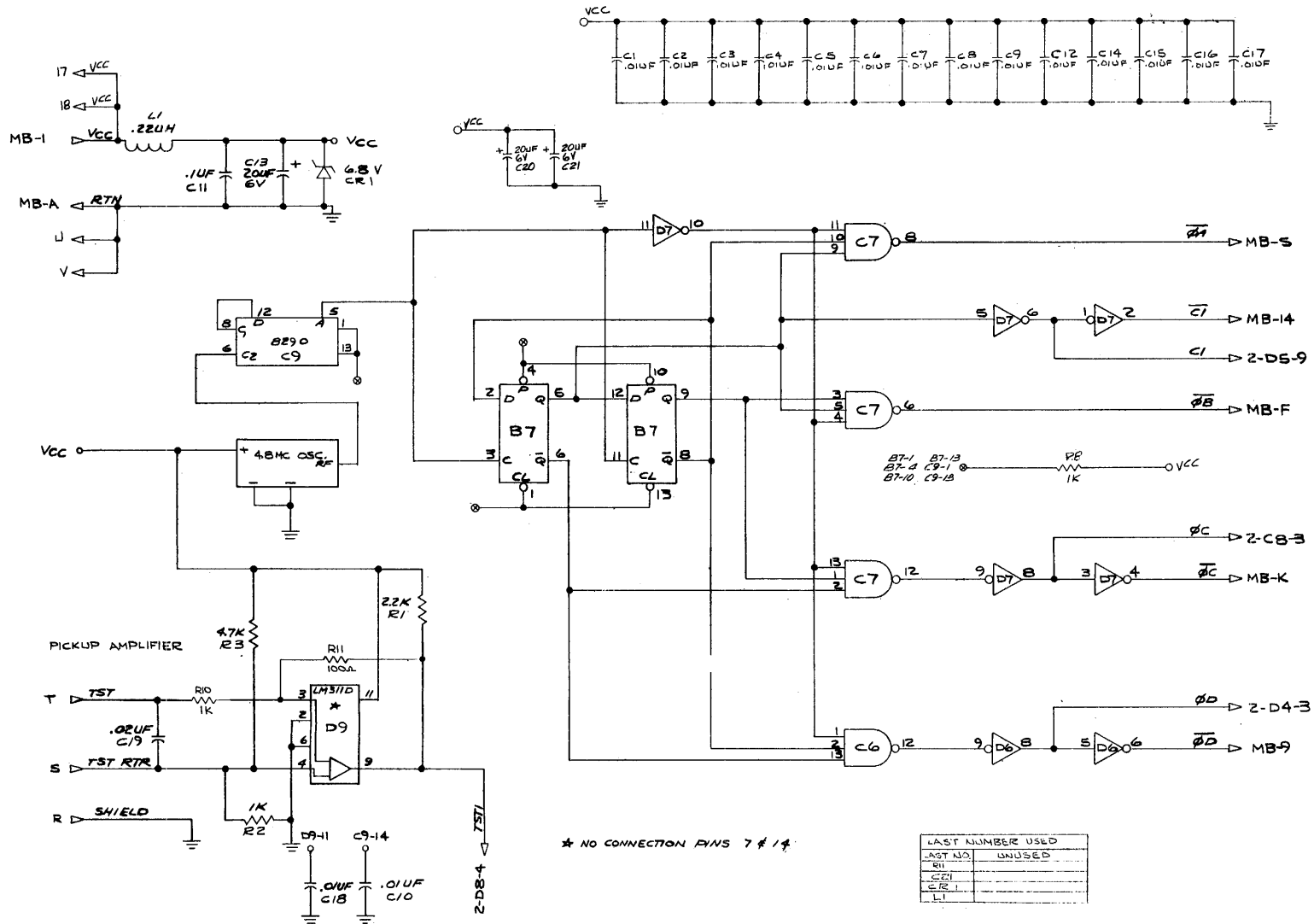

Figure A8. Clock Card Schematic (Sheet 1 of 3)
Dwg. No. 1040800A

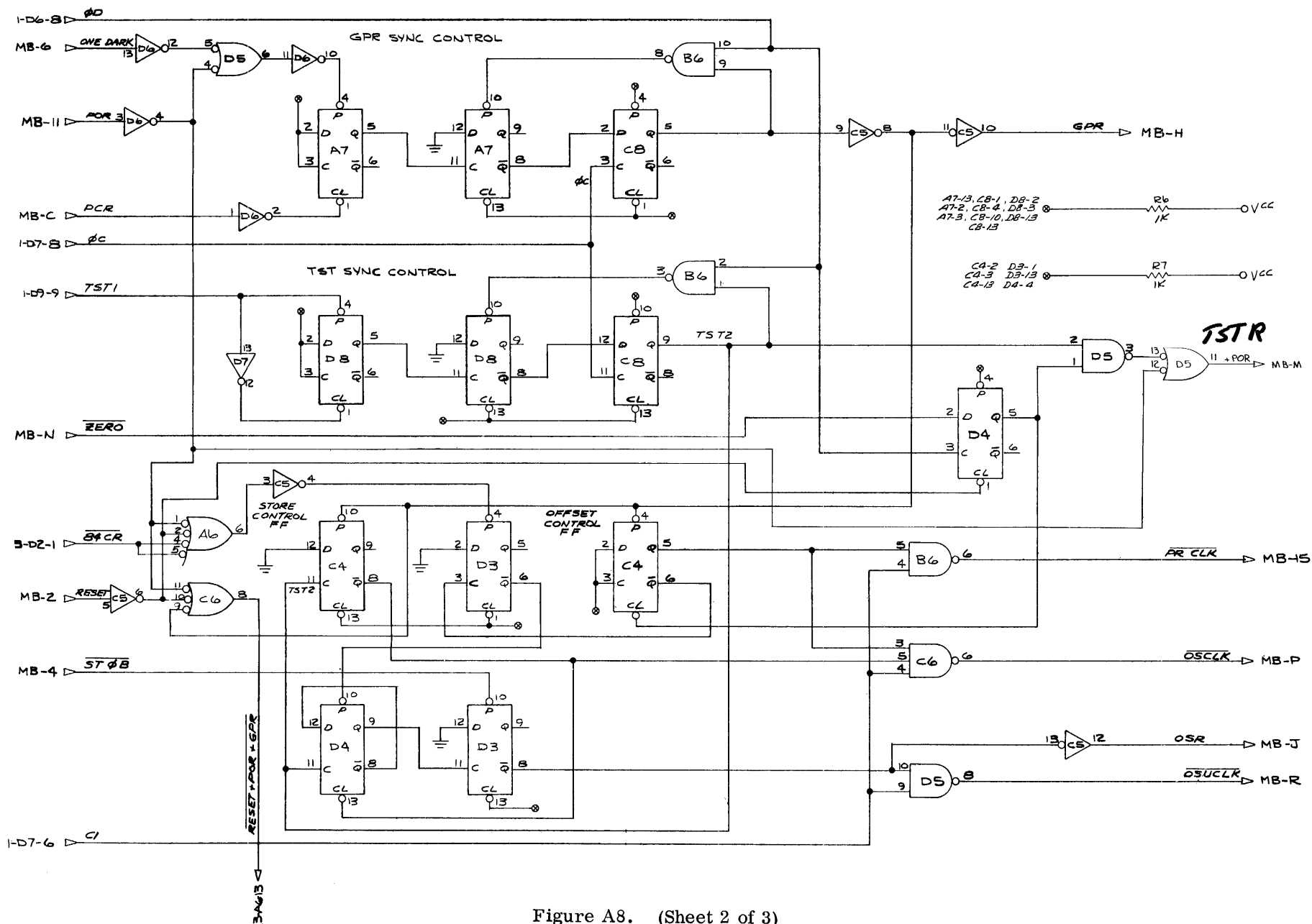
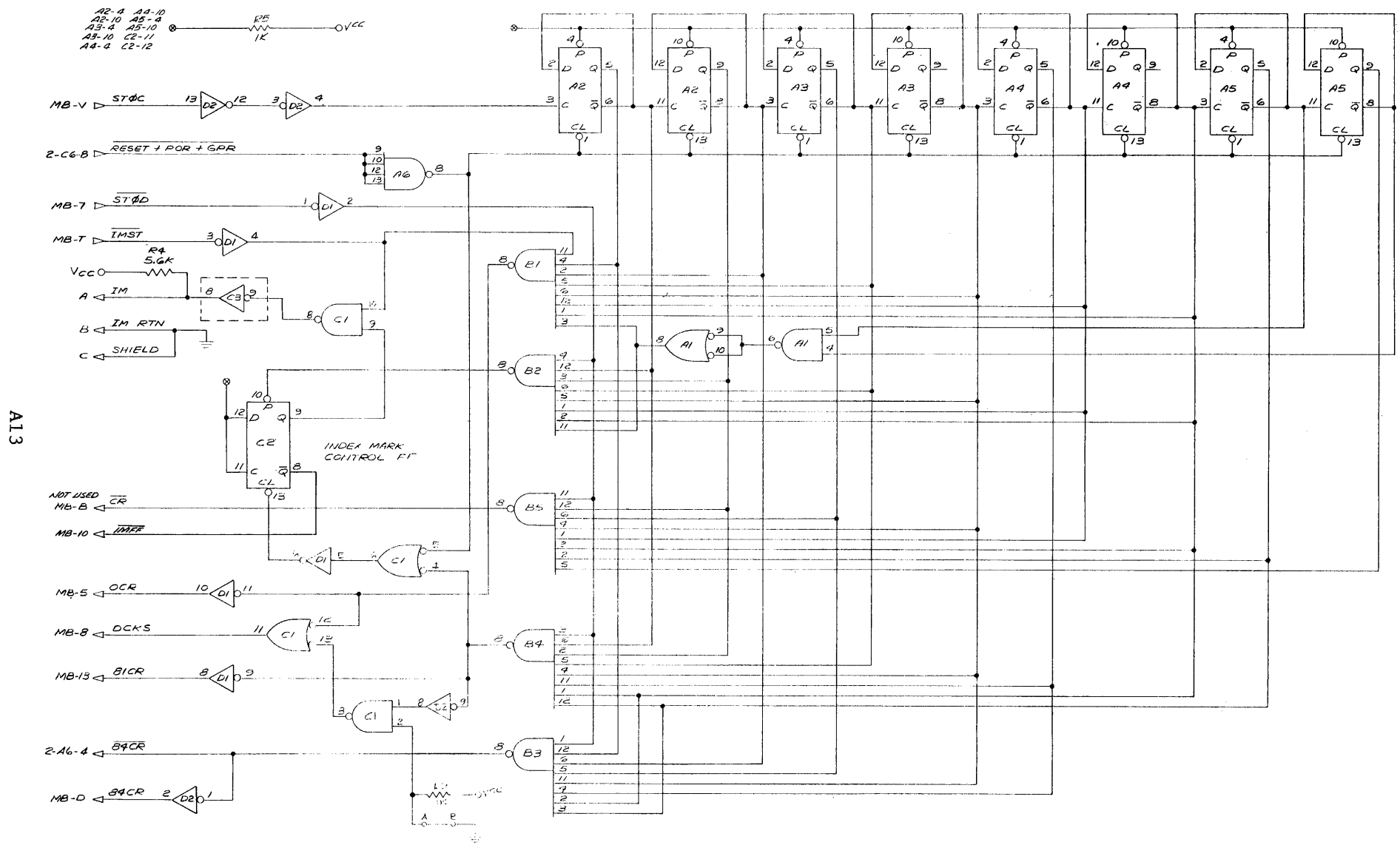

Figure A8. (Sheet 2 of 3)



A13

Figure A8. (Sheet 3 of 3)

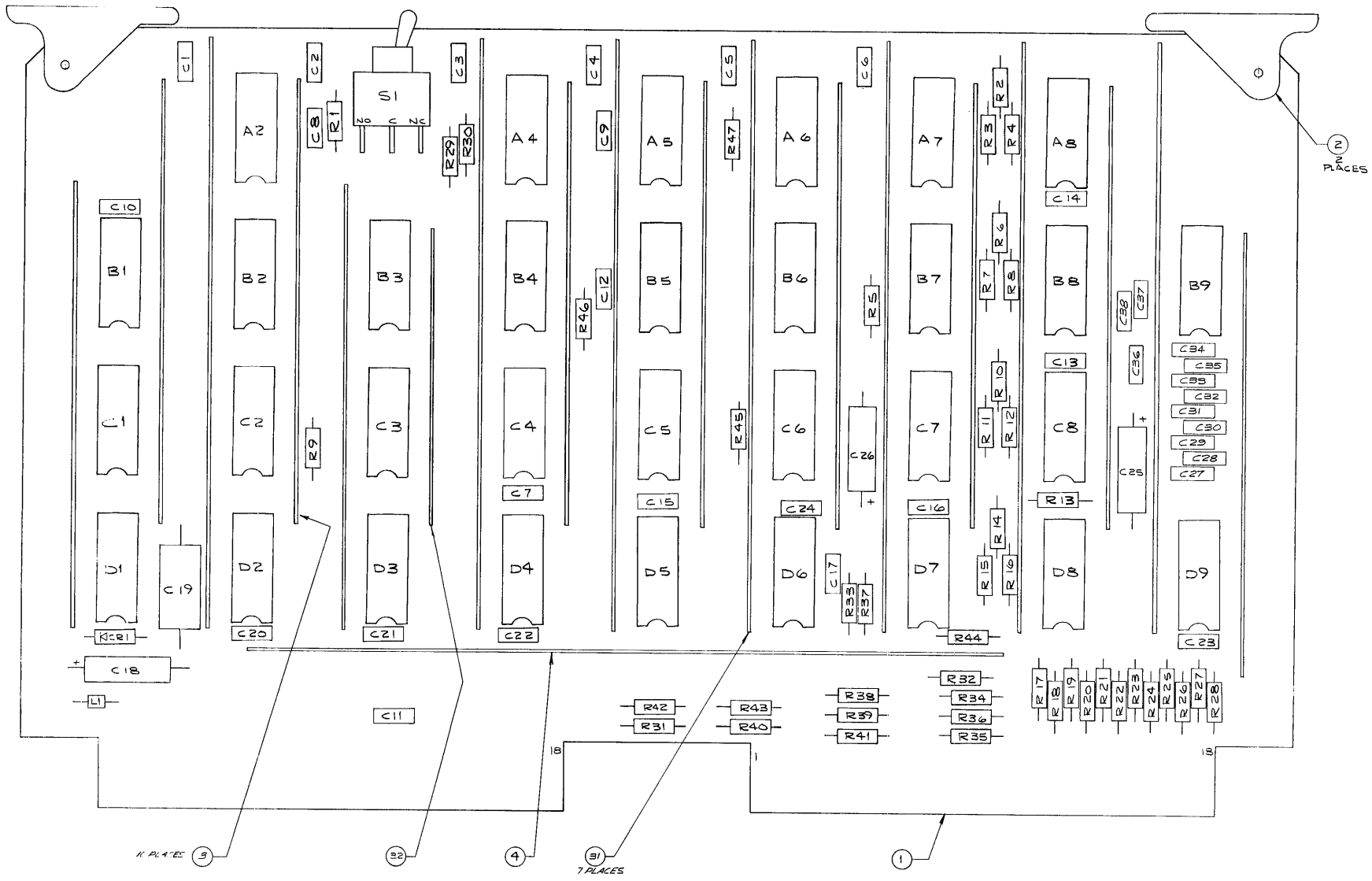

Figure A9. Control Card Assembly
Dwg. No. 1040619D

A15

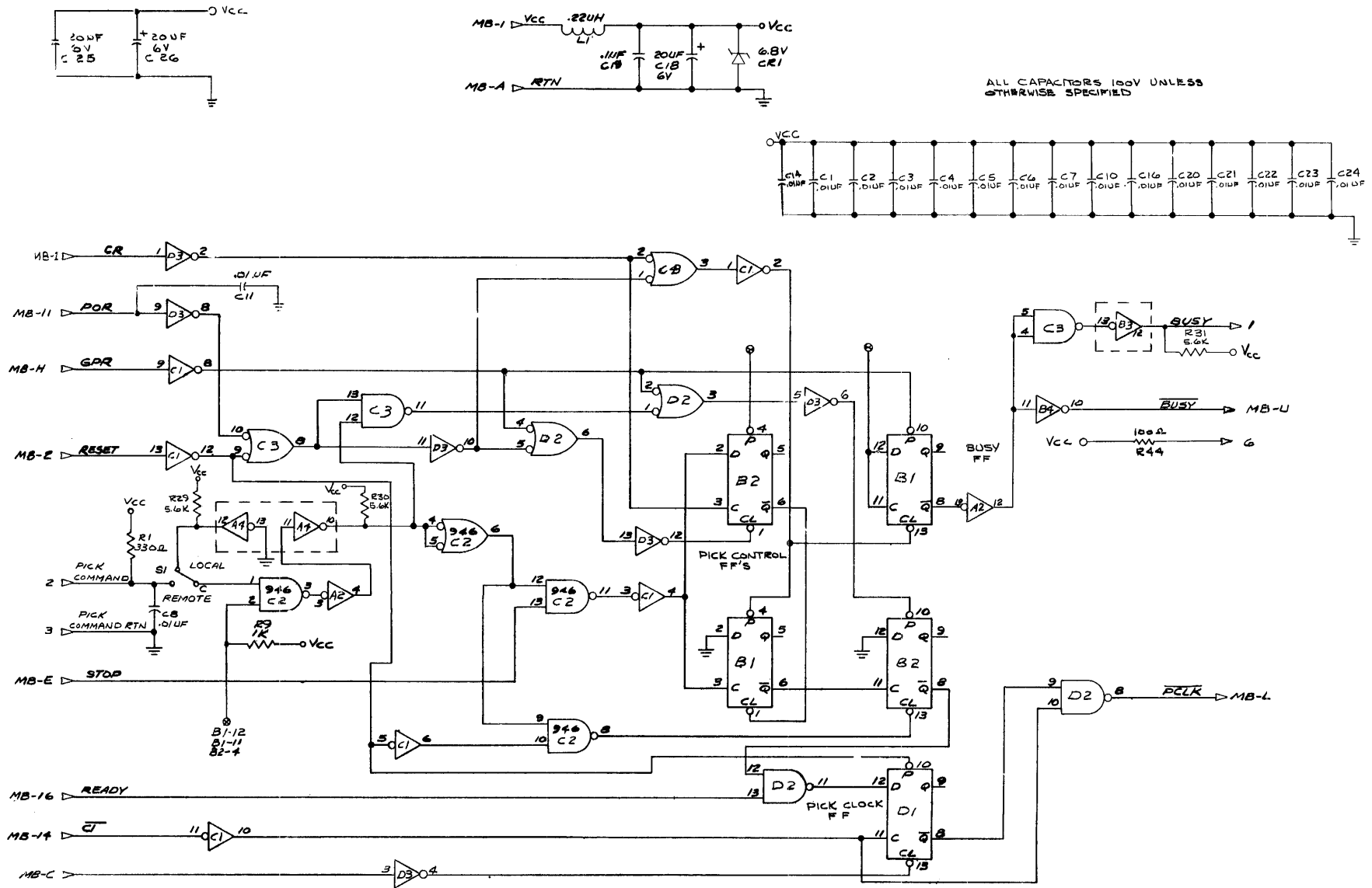

Figure A10. Control Card Schematic (Sheet 1 of 2)
 Dwg. No. 1040650C

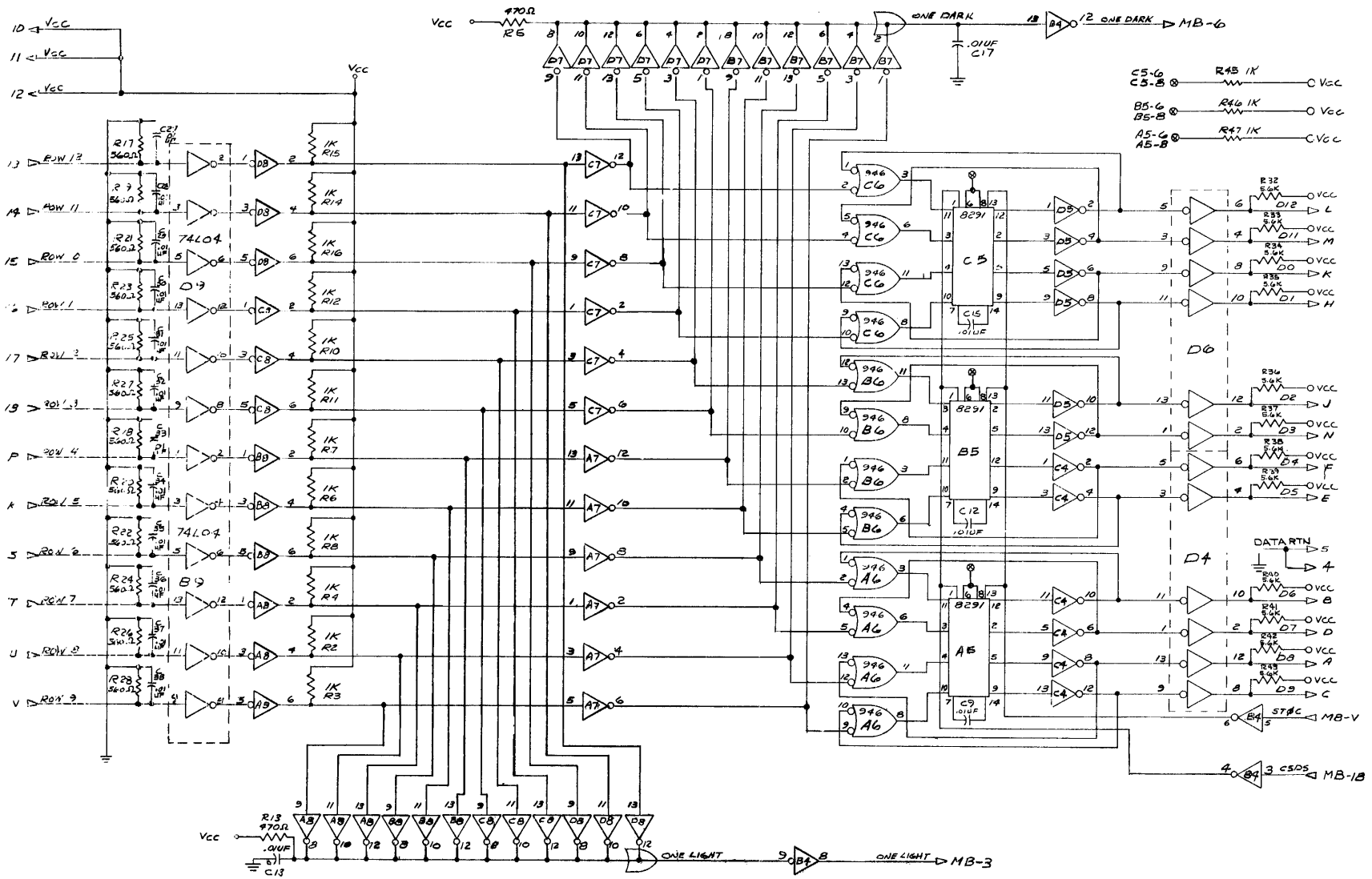

Figure A10. (Sheet 2 of 2)

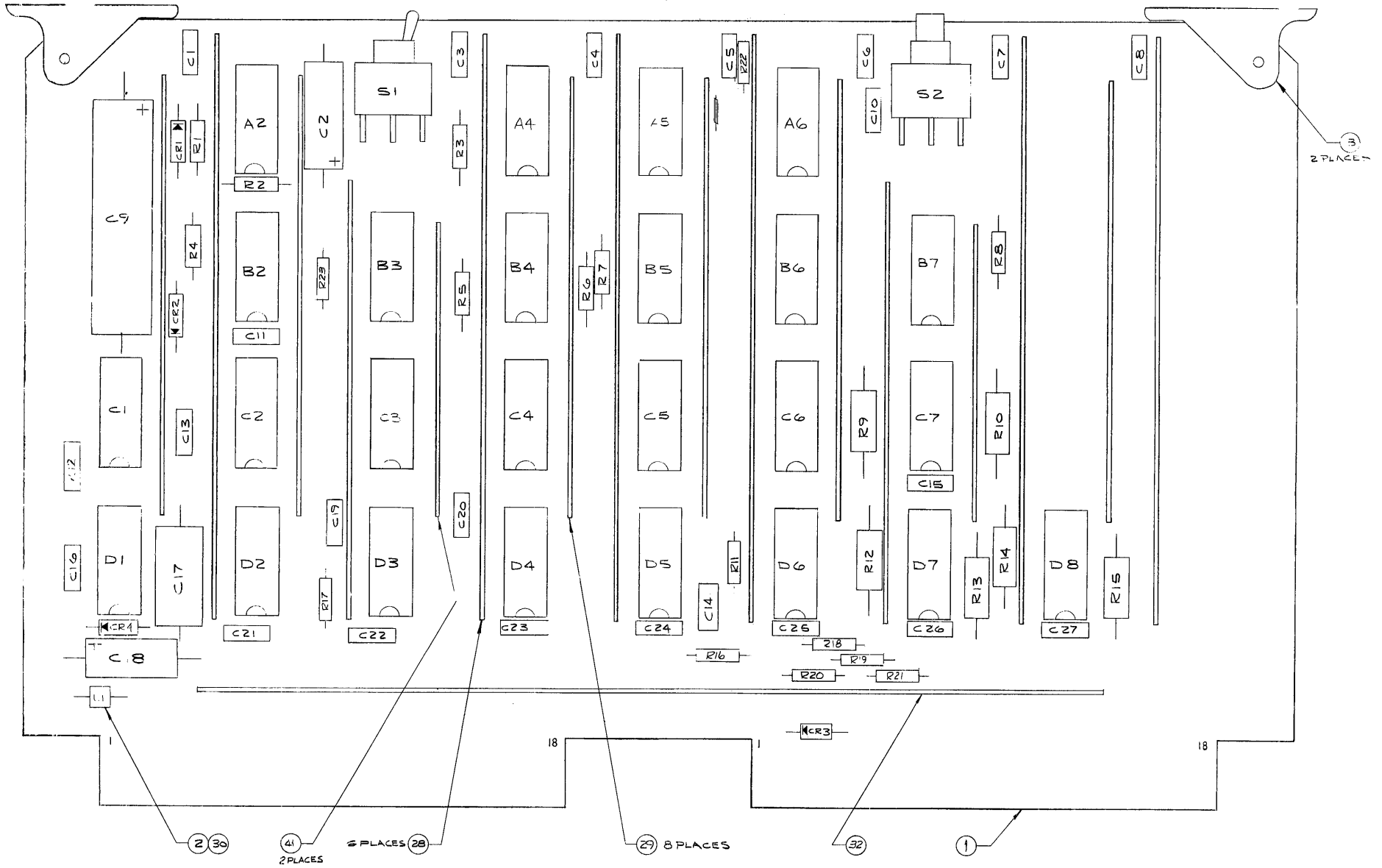
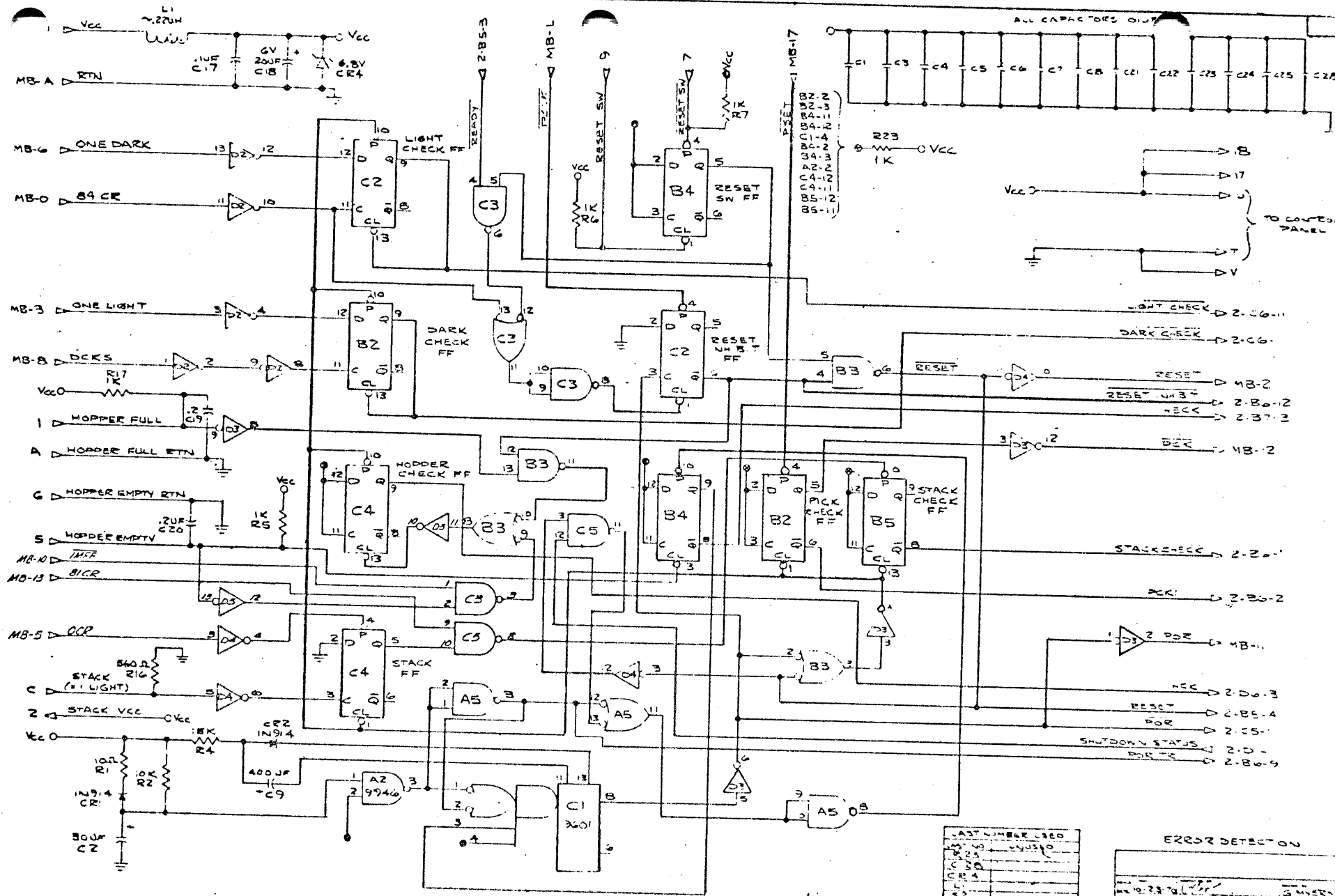

Figure A11. Error Card Assembly
Dwg. No. 1040610B



LAST NUMBER USED	
1	
2	
3	
4	
5	
6	
7	
8	
9	
10	
11	
12	
13	
14	
15	
16	
17	
18	
19	
20	
21	
22	
23	
24	
25	
26	
27	
28	
29	
30	
31	
32	
33	
34	
35	
36	
37	
38	
39	
40	
41	
42	
43	
44	
45	
46	
47	
48	
49	
50	

ERROR DETECTION

DATE: _____ TIME: _____

BY: _____

REVISION: _____

SCHEMATIC ERROR CARD

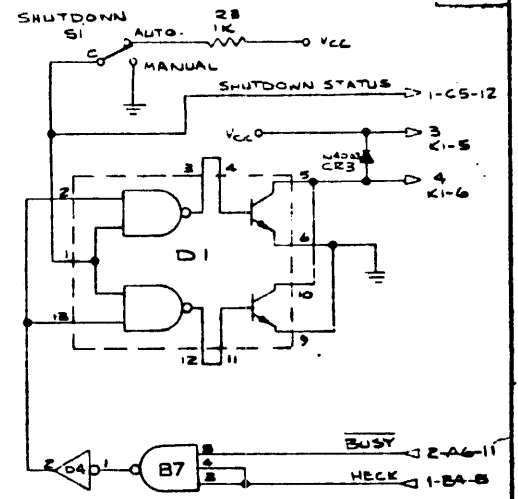
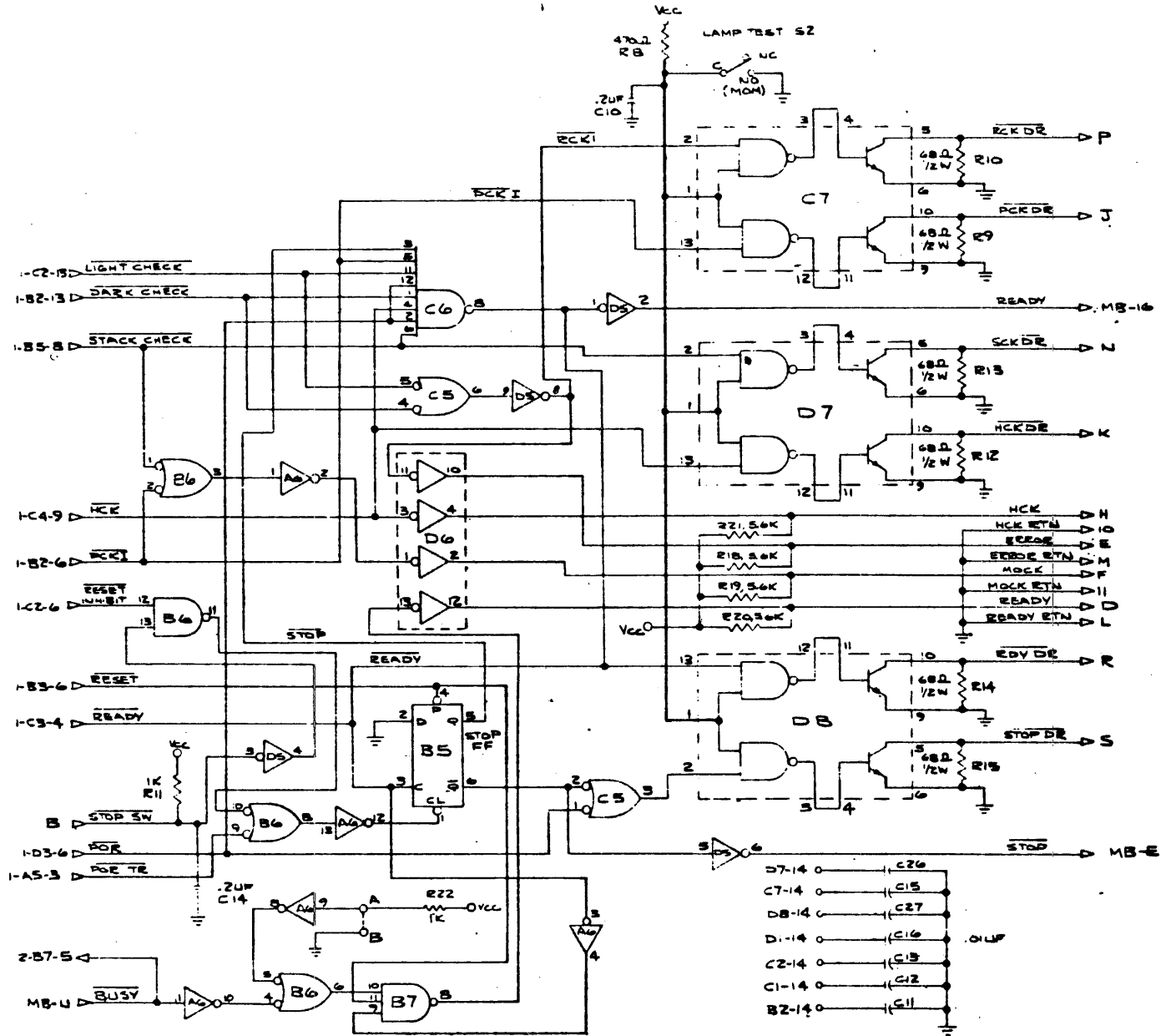

Resistor and capacitor value table:

D7-14	0	C26
C7-14	0	C15
D8-14	0	C27
D1-14	0	C16
C2-14	0	C13
C1-14	0	C12
B2-14	0	C11

LAMP DRIVERS

SCHEMATIC ERROR CARD 08084

APPENDIX B

PARTS LIST

The following parts list includes all items that are considered field replaceable. Should damage occur through excessive abuse to such items as the picker casting, reader housing, etc., the reader should be returned to Documation Incorporated for repair.

PARTS LIST

DESCRIPTION	MANUFACTURER	PART NUMBER	QTY PER READER
Assy., P.C. Card, Clock	Documation	1040655XX	1
Assy., P.C. Card, Control	Documation	1040619XX	1
Assy., P.C. Card, Error	Documation	1040610XX	1
Assy., P.C. Card, Sync	Documation	104035303	1
Assy., Blower	Documation	113055901	1
Assy., Control Panel	TEC	DPA-7164B	1
Assy., Light Station	Documation	103014401	1
Assy., Power Cord	Documation	1020148	1
Assy., Power Supply, 5 Volt	Documation	103029502	1
Assy., Read Array (includes magnetic pickup and stacker photocell)	Documation	113057201	1
Assy., Solenoid	Documation	112049801	1
Assy., Solenoid Driver	Documation	113045801	1
Assy., Switch, Hopper Empty	Documation	1020277	1
Assy., Timing Disc	Documation	1020223	1
Assy., Transformer, 12 Volt	Documation	102015602	1
Assy., Transformer, 24 Volt	Documation	102015502	1
Bearing, Sealed Ball	Kubar	SFR188TT(3)	8
Bearing, Stacker Rod	Torrington	B-59-OH	2
Belt, Blower	Gates	5M545	1
Belt, Drive	Dick	130XL025	1
Bulb; 6V @ 0.20A	GE	#328	7
Capacitor, Motor Run, <u>2</u> uf @ 330 VAC	CD	KKX33P205Q	1
Capacitor, Motor Run, 17.5uf @ 370 VAC	GE	45F279	1
Capacitor, 4600 uf @ 15 VDC	GE	86F119M	1
Capstan Drive	Documation	1020059	4
Circuit Breaker	Airpax	UPG1-16-2-802	1
Connector	AMP	583302-1	1
Connector	AMP	1-582191-5	5
Connector	AMP	583300-1	1
Connector	AMP	583334-1	4
Contact, Amp Leaf, 18-21 ga.	AMP	42717-4	4
Contact, Amp Leaf, 22-26 ga.	AMP	42839-4	59
Contact, Amp Modified Fork	AMP	583259-2	14
Contact, Elco	Elco	60-8017-0513	36

PARTS LIST

DESCRIPTION	MANUFACTURER	PART NUMBER	QTY PER READER
Contact, Terminal Junction	Deutsch	1841-1-5616	14
Coupling, Solenoid	Documation	1020105	1
Diode Bridge, 100V	Motorola	MDA 980-2	2
Fan, Cooling	Pamotor	4600	1
Filter, RFI	Components Corp.	10B1	1
Fuse, Slo-blo, 1A	Buss	313001	
Magnetic Pickup	Airpax	086-211-0019	1
Motor, Drive, 60 Hz, 1200 RPM	Motronics	34131-11-300-01	1
Motor, Blower, 60 Hz, 3350 RPM	GE	5KCP19PG190A	1
Mount, Rubber	Lord	100 PD2	2
Mount, Rubber	Lord	100 PD4	2
Pulley, Drive, Capstan	Dick	16XL037	1
Pulley, Drive Motor	Documation	112044801	1
Relay, Solid State	Hamlin	173-11-150	1
Shaft, Driver Roller	Documation	1010022	1
Shaft, Pick	Documation	1010039	1
Shaft, Stack Drive	Documation	101003001	1
Shaft, Stack Drive	Documation	101003002	1
Shaft, Stack Drive	Documation	101003003	1
Solenoid Lube No. 2	Ledex	124048-001	1
Spacer, Bearing	W. Berg	SS2-27	4
Spring, Solenoid	Lee Spring	LE-026-C2J	1
Spring, Stacker	Lee Spring	LE-041E-6(MW)	1
Stacker Photocell	Spectronics	SS1443	1
Switch, Hopper Full	Cherry	E21-85HX	1
Tie, Cable	Panduit	SST1M-M	20
Tie, Cable	Panduit	SST4-M	2

APPENDIX C

SIGNAL MNEMONICS AND ABBREVIATIONS

Appendix C contains the description, location and originating source for the Signal Mnemonics and Abbreviations used in this manual.

SIGNAL MNEMONICS AND ABBREVIATIONS

MNEMONIC	DESCRIPTION	LOCATION	ORIGINATING SOURCE
Vcc	+5 volts	MB-1	5 volt power supply (Mother Board)
RTN	+5 volt return	MB-A	5 volt power supply (Mother Board)
TST	Timing Strobe	J3-T	Reluctance Pickup
TST RTN	Timing Strobe Return	J3-S	Reluctance Pickup
SHIELD	Shield for Timing Strobe	J3-R	Reluctance Pickup
TST1	Timing Strobe One	D9-9	Clock Card
ϕA	Clock Phase A	MB-S	Clock Card
C1	Basic Clock	MB-14	Clock Card
ϕB	Clock Phase B	MB-F	Clock Card
ϕC	Clock Phase C	MB-K	Clock Card
ϕD	Clock Phase D	MB-9	Clock Card
ONE DARK	Read Station Any Dark	MB-6	Control Card
POR	Power On Reset	MB-11	Error Card
PCR	Pick Control Reset	MB-C	Sync Card
ZERO	Preset Decode	MB-N	Sync Card
RESET	Gated Reset Switch	MB-2	Sync Card
ST ϕB	Column Strobe Phase B	MB-4	Sync Card
GPR	Good Pick Reset	MB-H	Clock Card
TST2	Timing Strobe Two	C8-9	Clock Card
TSTR	Timing Strobe Reset	MB-N	Clock Card
PRCLK	Preset Clock	MB-15	Clock Card
OSCLK	Offset Clock	MB-P	Clock Card
OSR	Offset Reset	MB-J	Clock Card
OSUCLK	Offset Up-Clock	MB-R	Clock Card
ST ϕC	Column Strobe Phase C	MB-V	Sync Card
ST ϕD	Column Strobe Phase D	MB-7	Sync Card
IMST	Index Mark Strobes	MB-T	Sync Card
IM	Index Marks	J3-A	Clock Card
IM RTN	Return for Index Marks	J3-B	Clock Card
SHIELD	Shield for Index Marks	J3-C	Clock Card
CR	Column Reset	MB-B	Clock Card
OCR	Zero Column Reset	MB-5	Clock Card

SIGNAL MNEMONICS AND ABBREVIATIONS
(Continued)

MNEMONIC	DESCRIPTION	LOCATION	ORIGINATING SOURCE
DCKS	Dark Check Strobes	MB-8	Clock Card
81CR	81st Column Reset	MB-13	Clock Card
84CR	84th Column Reset	MB-D	Clock Card
PICK COMMAND	Pick Command Input	J8-2	Control Card
PICK COMMAND RTN	Pick Command Input Return	J8-3	Control Card
STOP	Stop	MB-E	Error Card
READY	Ready	MB-16	Error Card
BUSY	Busy Output	J8-1	Control Card
PCLK	Pick Clock	MB-L	Control Card
Vcc	+5V to Read Sensor Array	J8-12	Control Card
Row 12	Read Sensor Input Row 12	J8-13	Control Card
Row 11	Read Sensor Input Row 11	J8-14	Control Card
Row 0	Read Sensor Input Row 0	J8-15	Control Card
Row 1	Read Sensor Input Row 1	J8-16	Control Card
Row 2	Read Sensor Input Row 2	J8-17	Control Card
Row 3	Read Sensor Input Row 3	J8-18	Control Card
Row 4	Read Sensor Input Row 4	J8-P	Control Card
Row 5	Read Sensor Input Row 5	J8-R	Control Card
Row 6	Read Sensor Input Row 6	J8-S	Control Card
Row 7	Read Sensor Input Row 7	J8-T	Control Card
Row 8	Read Sensor Input Row 8	J8-U	Control Card
Row 9	Read Sensor Input Row 9	J8-V	Control Card
ONE LIGHT	Read Station Any Light	MB-3	Control Card
D12	Data Row 12 Output	J8-L	Control Card
D11	Data Row 11 Output	J8-M	Control Card
D0	Data Row 0 Output	J8-K	Control Card
D1	Data Row 1 Output	J8-H	Control Card
D2	Data Row 2 Output	J8-J	Control Card
D3	Data Row 3 Output	J8-N	Control Card
D4	Data Row 4 Output	J8-F	Control Card
D5	Data Row 5 Output	J8-E	Control Card
RTN	Data Drivers Return	J8-5	Control Card
D6	Data Row 6 Output	J8-B	Control Card

SIGNAL MNEMONICS AND ABBREVIATIONS
(Continued)

MNEMONIC	DESCRIPTION	LOCATION	ORIGINATING SOURCE
D7	Data Row 7 Output	J8-D	Control Card
D8	Data Row 8 Output	J8-A	Control Card
D9	Data Row 9 Output	J8-C	Control Card
CSDS	Column Storage Data Strobe	MB-18	Sync Card
HOPPER FULL	Hopper Full Switch	J4-1	Error Card
HOPPER FULL RTN	Hopper Full Switch Return	J4-A	Error Card
HOPPER EMPTY RTN	Hopper Empty Switch Return	J4-6	Error Card
HOPPER EMPTY	Hopper Empty Switch	J4-5	Error Card
STACK	Stack Sensor Input	J4-C	Error Card
STACK Vcc	Stack Sensor +5 volts	J4-2	Error Card
RESET SW	Reset Switch Normally Open	J4-9	Error Card
<u>RESET SW</u>	Reset Switch Normally Closed	J4-7	Error Card
PSET	Pick Check Set	MB-17	Sync Card
LIGHT CHECK	Light Check	C2-9	Error Card
DARK CHECK	Dark Check	B2-9	Error Card
HECK	Hopper Empty Check	B4-8	Error Card
PCK	Pick Check	B2-5	Error Card
STACK CHECK	Output Stacker Check	B5-8	Error Card
PCKI	Pick Check Indicator	B2-2	Error Card
HCK	Input or Output Hopper Check	C4-9	Error Card
SHUTDOWN STATUS	Mode Switch Input	S1-C	Error Card
POR TR	Power on Reset Trigger	A5-12	Error Card
STOP SW	Stop Switch Input	J4-B	Error Card
RCK DR	Read Check Lamp Driver	J4-P	Error Card
PCK DR	Pick Check Lamp Driver	J4-P	Error Card
SCK DR	Stack Check Lamp Driver	J4-N	Error Card
HCK DR	Hopper Check Lamp Driver	J4-K	Error Card
HCK	Hopper Check Output	J4-H	Error Card
HCK RTN	Hopper Check Output Return	J4-10	Error Card
ERROR	Error Output	J4-E	Error Card
ERROR RTN	Error Output Return	J4-M	Error Card
MOCK	Motion Check Output	J4-F	Error Card

SIGNAL MNEMONICS AND ABBREIVATIONS
(Continued)

MNEMONIC	DESCRIPTION	LOCATION	ORIGINATING SOURCE
MOCK RTN	Motion Check Output Return	J4-11	Error Card
READY	Ready Output	J4-D	Error Card
READY RTN	Ready Output Return	J4-L	Error Card
RDY DR	Ready Lamp Driver	J4-R	Error Card
STOP DR	Stop Lamp Driver	J4-S	Error Card
PICK	Pick Driver Output	J5-A	Sync Card
PICK RTN	Pick Driver Output Return	J5-B	Sync Card
SHIELD	Shield for PICK	J5-C	Sync Card
BUSY	Busy Signal	MB-U	Control Card

DOCUMENTATION

SERIALIZED

ITEM	PART NUMBER	DESCRIPTION	QUANTITY
	58259-2LP	AMP Modified Form 583259-2LP	30 29-18
	1030213	Assy, Follower, Picker	1
1516	1030144	Assy, Light Station	1
1491	1040765-03	Assy, P.C. Card, Clock	1
9490	1040845-01	Assy, P.C. Card, Control	1
	1040XXX-XX	Assy, P.C. Card, Error	1
	1040XXX-XX	Assy, P.C. Card, Sync	1
1435	1030295-02	Assy, Power Supply, 5V	1
	1030142	Assy, Read Array	1
	1020174	Assy, Relay	1
422	1020225 -02	Assy, Solenoid	1
	1030100- 01 01	Assy, Solenoid Driver 1030100-02	1 29-194
1409	1020382 - 01 01	Assy, Stack Photocell 1020382-02	1 29-194
5523	1020277	Assy, Switch, Hopper Empty	1
9619	1020211	Assy, Switch, Stacker Full	1
9419	1010223	Assy, Timing Disc	1
8526	1020156 01	Assy, Transformer, 12V	1
8527	1020155 02	Assy, Transformer, 24V	1
	SSR1F-814LLR	Bearing, Sealed Ball	8
1530	5M545	Belt, Blower	1
1478	70XL-025	Belt, Drive	1
1419	80XL-025	Belt, Drive	1
1481	160XL-025	Belt, Drive	2
	553-1	Blower	1
100	#328	Bulb, 6V @ 0.2A	7
1535	86F119M	Capacitor, 4600 uf @ 15 VDC	1
	KKX330405Q	Capacitor, Motor Run 4 uf @ 330 VAC (supplied with Drive Motor)	1
534	45F279	Capacitor, Motor Run, 17.5uf @370 VAC	1
536	1020059	Capstan, Drive	4
537	UPG1162802	Circuit Breaker, 8A	1
538	42717-4LP	Contact, AMP Leaf 18-21 ga.	30
539	42702-3LP	Contact, AMP Leaf 22-26 ga.	30
541	6080170313	Contact, Elco	30
542	1841-1-5616	Contact, Terminal Junction	100
469	1010105	Coupling, Solenoid	1
545	MK IV Muffin	Fan, Muffin Mk IV	1
	0080160 38000707	Housing, Output Conn. (J2)	1
556	124048-001	Lube, No. 2	1
	HB-1800	Motor, Drive 1800 RPM @ 60Hz	1
548	KCP19PG	Motor, 60 Hz 3350 RPM, Blower	1
549	100PD2	Mount, Rubber	2
50	100PD4	Mount, Rubber	2
50	1020161	Pickup Assy, Magnetic	1
17	1020148	Power Cord Assy	1
47	14XL-037	Pulley, Drive, Nylon	3
49	15XL-037	Pulley, Drive, Nylon	3

	47	MDA980-1	Rectifier Diode Bridge, 50V MDA-980-2	2	29-1948
SS3	48	1010022	Shaft, Drive Roller	2	
SS4	49	1010039	Shaft, Pick	1	
SS56	50	1010030-02	Shaft, Stack Drive	5	
SS57	51	1010030-03	Shaft, Stack Drive	1	
	52	5100-2S	Snap Ring, 1/4"	4	
SS59	53	SS2-28	Spacer, Bearing	4	
9629	54	LE-037-DE-11	Spring, Hopper	1	
9450	55	SL5E17	Spring, Negator	1	
9448	56	SL6F24	Spring, Negator	1	513-2410-004
8560	57	LE-026-C2-J	Spring, Solenoid	1	29-19630
	58	513-1410-004	Switch, Alt. Act., White Barrier	1	
9631	59	513-1610-004	Switch, N.O., Snap Action	1	
9632	60	513-0110-004	Switch, N.O., SPST, White Barrier	1	
8563	61	SST-1 M	Tie, Cable	100	
8564	62	SST-4 C	Tie, Cable	100	