Model F880ES
Technical Manual

eipher®

Caution

This unit requires the use of a shielded interface cable.

Federal Communications Commission (FCC) Notice

WARNING: This equipment generates, uses, and can radiate radio frequency energy and if not installed and used in accordance with the instructions manual, may cause interference to radio communications. It has been tested and found to comply with the limits for a Class A computing device pursuant to Subpart J of Part 15 of FCC Rules, which are designed to provide reasonable protection against such interference when operated in a commercial environment. Operation of this equipment in a residential area is likely to cause interference in which case users at their own expense will be required to take whatever measures may be required to correct the interference.

VDE Statement

Hiermit wird bescheinigt, dass der Model F880ES in Ubereinstimmung mit den Bestimmungen der Vfg 1046/1984 funkentstort ist.

Der Deutschen Bundespost wurde das Inverkehrbringen dieses Gerates angezeigt und die Berechtigung zur Uberprufung der Serie auf Einhaltung der Bestimmungen eingeräumt.

Canadian Radio Noise Emissions Notice

This digital apparatus does not exceed the Class A limits for radio noise emissions from digital apparatus as set out in the radio interference regulations of the Canadian Department of Communications.

Le présent appareil numérique n'émet pas de bruits radioélectriques dépassant les limites applicables aux appareils numériques de Classe A prescrites dans le règlement sur le brouillage radioélectrique édicté par le Ministère Des Communications Du Canada.

Proprietary Statement

All information contained in or disclosed by this document is considered proprietary by Cipher Data Products, Inc. By accepting this material the recipient agrees that this material and the information contained therein are held in confidence and in trust and will not be used, reproduced in whole or in part, nor its contents revealed to others, except to meet the purpose for which it was delivered. It is understood that no right is conveyed to reproduce or have reproduced any item herein disclosed without express permission from Cipher Data Products, Inc.

Cipher Data Products, Inc. provides this manual "as is," without warranty of any kind, either expressed or implied, including, but not limited to, the implied warranties of merchantability and fitness for a particular purpose. Cipher may make improvements or changes in the product(s) or programs described in this manual at any time. These changes will be incorporated in new editions of this publication.

Cipher Data Products, Inc. assumes no responsibility for the accuracy, completeness, sufficiency, or usefulness of this manual, nor for any problem that might arise from the use of the information in this manual.

Notice

This manual is provided for qualified technicians only.

Record of Revision

Edition	Description	Date
A	Released per ERO SD-89-0402	11/89

Table of Contents

Chapter 1 Description

Overview	1-1
General Description	1-1
Functional Description	1-1
Physical Description	1-2
Tape Path and Service Access	1-3
Operator Access	1-3
Service Access	1-4
Parts Locations	1-8
Front View	1-8
Rear View	1-9
Top View	1-10
Bottom View	1-11

Chapter 2 Installation and Configuration

Overview	2-1
Unpacking	2-1
Installation	2-1
Rack Mounting	2-1
Enclosure Installation	2-4
AC Voltage Selection	2-6
Interface Cable	2-8
Configuration	2-14
SCSI ID	2-14
Configuration Options	2-15
Bus Terminator	2-16

Chapter 3 Operation

Introduction	3-1
Front Panel	3-1
LOAD/REWIND	3-2
UNLOAD	3-2
ON-LINE	3-2
WRIT EN/TEST	3-2
HI DEN	3-2
Power Switch	3-2
Loading Tape	3-3
Manual Load	3-3
Unloading Tape	3-6
Manual Unload	3-6

Chapter 4 Maintenance

Introduction	4-1
Tape Path	4-1
Sensors	4-2
Filter	4-3

Chapter 5 Troubleshooting

Introduction	5-1
Errors	5-1
Error Reporting	5-1
Error Codes	5-1
Drive Diagnostics	5-2
Diagnostic Mode Entry	5-2
Tape Unloaded Diagnostics	5-3
Tape Loaded Diagnostics	5-9
SCSI Diagnostics	5-9
Sense Keys	5-9
Additional Sense	5-9
Status Bytes	5-10
Diagnostic Commands	5-10
SCSI Power-up Diagnostics	5-10

Chapter 6 Removal, Replacement, and Adjustment Procedures

Introduction	6-1
Tools and Materials	6-1
Part Numbers	6-2
Removal and Replacement Procedures	6-4
Blower	6-4
Control Switches	6-5
Door	6-6
Door Lock	6-7
EOT/BOT Sensors	6-9
File-Protect Sensor	6-10
Front Panel	6-11
Fuse	6-13
Hub Lock Solenoid	6-14
Input Air Duct	6-15
Interlock Switch	6-16
Left Output Air Duct	6-17
Main Circuit Board	6-18
Manual Release Switch	6-19
Power Supply Circuit Board	6-20
Power Switch	6-22
Read/Write Head	6-23
Right Output Air Duct	6-24
Roller Guide 1	6-25
Roller Guide 2	6-26
Roller Guides 3, 4, 5	6-27
Supply Hub	6-28
Supply Hub Bell Crank	6-29
Supply Motor	6-30
Tachometer	6-32
Take-Up Hub	6-34
Take-Up Motor	6-35
Tape-In-Path Receiver	6-37
Tape-In-Path Transmitter	6-38
Tension Arm, Stator, and Rotor	6-39
Top Cover	6-42
Transformer	6-43
Adjustment Procedures	6-44
Interlock Disable Procedure	6-44

Read Threshold Adjustment	6-45
Skew Adjustment	6-46
Supply Hub Adjustment	6-48
Take-Up Hub Adjustment	6-49
Tape Alignment Adjustment	6-51
Tension Arm Output Adjustment	6-53
Tension Arm Spring Adjustment	6-55

Chapter 7 Small Computer Systems Interface

Introduction	7-1
SCSI Characteristics	7-1
Signals	7-1
Acknowledge	7-1
Attention	7-1
Busy	7-1
Control/Data	7-2
Data Bus	7-2
Input/Output	7-2
Message	7-2
Request	7-2
Reset	7-2
Select	7-2
Messages	7-3
Status	7-3
Commands	7-4
Command Descriptor Block	7-5
Copy (18h)	7-6
Erase (19h)	7-8
Inquiry (12h)	7-9
Load/Unload (1Bh)	7-10
Mode Select (15h)	7-11
Mode Sense (1Ah)	7-13
Read (08h)	7-14
Read Block Limits (05h)	7-15
Read Reverse (0Fh)	7-16
Receive Diagnostic (1Ch)	7-17
Recover Buffered Data (14h)	7-18
Release Unit (17h)	7-19

Request Sense (03h)	7-20
Reserve Unit (16h)	7-27
Rewind (01h)	7-28
Send Diagnostic (1Dh)	7-28
Space (11h)	7-30
Test Unit Ready (00h)	7-31
Verify (13h)	7-32
Write (0Ah)	7-34
Write File Mark (10h)	7-35

Chapter 8 Specifications

Performance	8-1
Interface	8-2
Mechanical Specifications	8-2
Power	8-2
Environmental Specifications	8-3
Acoustic Noise Emission	8-3
Shock	8-3
Interface Cable	8-3

Engineering Drawings

Main Circuit Board	966129-300
Power Supply	960877-300
Harness	360101-320
Wiring Diagram	966104-300
Rack Mounting	960264-000

Regulatory Requirements	8-3
Safety	8-3
Electromagnetic Emissions	8-3
Tape	8-4

List of Figures

1-1. F880ES Rack-Mount Tape Drive	1-2
1-2. Location of Rack Latch and Cover Retainer Arm	1-3
1-3. Location of Deck Plate Retainer Screws	1-5
1-4. Inserting Safety Pin Into Support Arm	1-6
1-5. Front Parts	1-8
1-6. Rear Parts	1-9
1-7. Top Parts	1-10
1-8. Bottom Parts	1-11
2-1. Rack Mount	2-2
2-2. Installation into an Enclosure	2-5
2-3. Installation of a SCSI Cable in an Enclosure	2-6
2-5. Termination for Single-Ended Devices	2-9
2-6. Termination for Differential Devices	2-9
2-7. DIP Switches U2C and U4A	2-14
2-8. Installation of Terminator Plug	2-16
3-1. Front Panel	3-1
3-2. Location of Manual Release Switch	3-4
3-3. Tape Path	3-5
4-1. Tape Path and Sensors	4-2
4-2. Air Filter	4-3
5-1. Bit Significance of Front Panel Indicators	5-1
5-2. Front Panel Switches Decimal Numbered	5-3
5-3. Tachometer Phase Quadrature	5-4
5-4. Location of Diagnostic LEDs	5-11
6-1. Blower	6-4
6-2. Control Switches	6-5
6-3. Door	6-6

6-4. Door Lock	6-8
6-5. EOT/BOT Sensors	6-9
6-6. File-Protect Sensor	6-10
6-7. Front Panel	6-12
6-8. Fuse	6-13
6-9. Hub Lock Solenoid	6-14
6-10. Input Air Duct	6-15
6-11. Interlock Switch	6-16
6-12. Left Output Air Duct	6-17
6-13. Main Circuit Board	6-18
6-14. Manual Release Switch	6-19
6-15. Power Supply Circuit Board	6-21
6-16. Power Switch	6-22
6-17. Read/Write Head	6-23
6-18. Right Output Air Duct	6-24
6-19. Roller Guide 1	6-25
6-20. Roller Guide 2	6-26
6-21. Roller Guides 3, 4, 5	6-27
6-22. Supply Hub	6-28
6-23. Supply Hub Bell Crank	6-29
6-24. Supply Motor	6-31
6-25. Tachometer	6-32
6-26. Take-Up Hub	6-34
6-27. Take-Up Motor	6-36
6-28. Tape-In-Path Receiver	6-37
6-29. Tape-In-Path Transmitter	6-38
6-30. Tension Arm	6-40
6-31. Top Cover	6-42
6-32. Transformer	6-43
6-33. Location of Read Threshold Potentiometer	6-45
6-34. Location of Skew Adjustment Screw	6-46
6-35. Skew Adjustment Waveform	6-47
6-36. Supply Hub Adjustment	6-48
6-37. Take-Up Hub Adjustment	6-49
6-38. Tension Arm Adjustment	6-53

List of Tables

2-1. AC Voltage Selection	2-8
2-2. Single-Ended Unshielded and Alternative 1 Pin Assignments	2-10
2-3. Single-Ended Alternative 2 Pin Assignments	2-11
2-4. Differential Alternative 1 Pin Assignments	2-12
2-5. Differential Alternative 2 Pin Assignments	2-13
2-6. SCSI ID Switch Settings	2-14
2-7. Configuration Options, DIP Switch U4A	2-15
5-1. Error Codes	5-2
5-2. Service Aids 22 and 23 Conversion Chart (1 of 2)	5-5
5-3A. Service Aid 24 Low-Order Bits Conversion Chart	5-8
5-3B. Service Aid 24 High-Order Bits Conversion Chart	5-9
5-4. Level 0 Diagnostics Error Codes	5-11
6-1. Special Tools and Materials List	6-1
6-2. Part Numbers of Replaceable Items (1 of 2)	6-2
6-3A. Value of Tension Arm Output Voltage (HI DEN LED on)	6-54
6-3B. Value of Tension Arm Output Voltage (HI DEN LED off)	6-55
7-1. Message Set	7-3
7-2. Status Bytes	7-3
7-3. Command Set	7-4
7-4. Command Descriptor Block Format	7-5
7-5. Copy Command	7-6
7-6. Copy Command Parameter List Header	7-7
7-7. Segment Descriptor for Copy Function Codes 00h and 01h	7-7
7-8. Erase Command	7-8
7-9. Inquiry Command	7-9
7-10. Inquiry Data	7-10
7-11. Load/Unload Command	7-10
7-12. Mode Select Command	7-11
7-13. Mode Select Parameter List Header	7-12
7-14. Mode Select Block Descriptor	7-12
7-15. Mode Select Page 0 Descriptor	7-13
7-16. Mode Sense Command	7-13
7-17. Mode Sense Parameter List Header	7-14
7-18. Read Command	7-15
7-19. Read Block Limits Command	7-15

7-20. Read Block Limits Data	7-16
7-21. Read Reverse Command	7-16
7-22. Receive Diagnostic Command	7-17
7-23. Receive Diagnostic Results Data	7-18
7-24. Recover Buffered Data Command	7-19
7-25. Release Unit Command	7-19
7-26. Request Sense Command	7-20
7-27. Extended Sense Data for All Commands, Bytes 0-7	7-21
7-28. Extended Sense Data for a Copy Command	7-22
7-29. Extended Sense Data for a Non-Copy Command	7-23
7-30. Sense Keys	7-25
7-31. Additional Sense Codes	7-26
7-32. Tape Status Port 3	7-27
7-33. DMA Status	7-27
7-34. Reserve Unit Command	7-28
7-35. Rewind Command	7-28
7-36. Send Diagnostic Command	7-29
7-37. Send Diagnostic Data	7-30
7-38. Space Command	7-31
7-39. Test Unit Ready Command	7-32
7-40. Verify Command	7-32
7-41. Write Command	7-34
7-42. Write File Mark Command	7-36
8-1. Operating Times	8-1

Chapter 1 Description

INTRODUCTION

This chapter provides general, functional, and physical descriptions of the F880ES tape drive. It also has instructions on how to open up the drive to gain access for operation and servicing, and a series of illustrations showing the locations of all the major parts of the tape drive.

GENERAL DESCRIPTION

The Cipher Model F880ES is a dual-density (1600 and 3200 bits per inch) magnetic tape drive designed to provide backup for high-capacity disk drives and data interchange between systems. The F880ES exchanges data with other components of a SCSI system and transfers that data to and from half-inch tape reels of 7, 8.5, and 10.5 inches.

Figure 1-1 is an illustration of an F880ES tape drive.

FUNCTIONAL DESCRIPTION

The F880ES drive is made up of three functional components: the interface, the drive electronics, and the drive mechanism. These three elements interact to accomplish the various functions performed by the drive.

The drive records on tape data transmitted across the SCSI bus and reads recorded data from tape and transfers it to the SCSI bus. To perform these functions a microprocessor interprets commands from the interface, accelerates and decelerates the tape, positions the tape at the read/write head, detects tape position, controls formatting, and provides status outputs.

The drive writes data to tape using the phase encode method of recording. Nine tracks are written simultaneously across the width of the tape, eight tracks of data and a parity track.

The tape drive is self-loading. The operator inserts a reel of tape in the opening of the front panel and presses a load switch. The drive then automatically seats the reel on the supply hub, threads the tape around the tension arm, across the read/write head, and around the take-up hub. The tape is positioned at BOT and properly tensioned.

The interface translates SCSI commands arriving on the SCSI bus into drive executable commands, and it also translates tape drive data and status signals into the appropriate format for the SCSI bus.

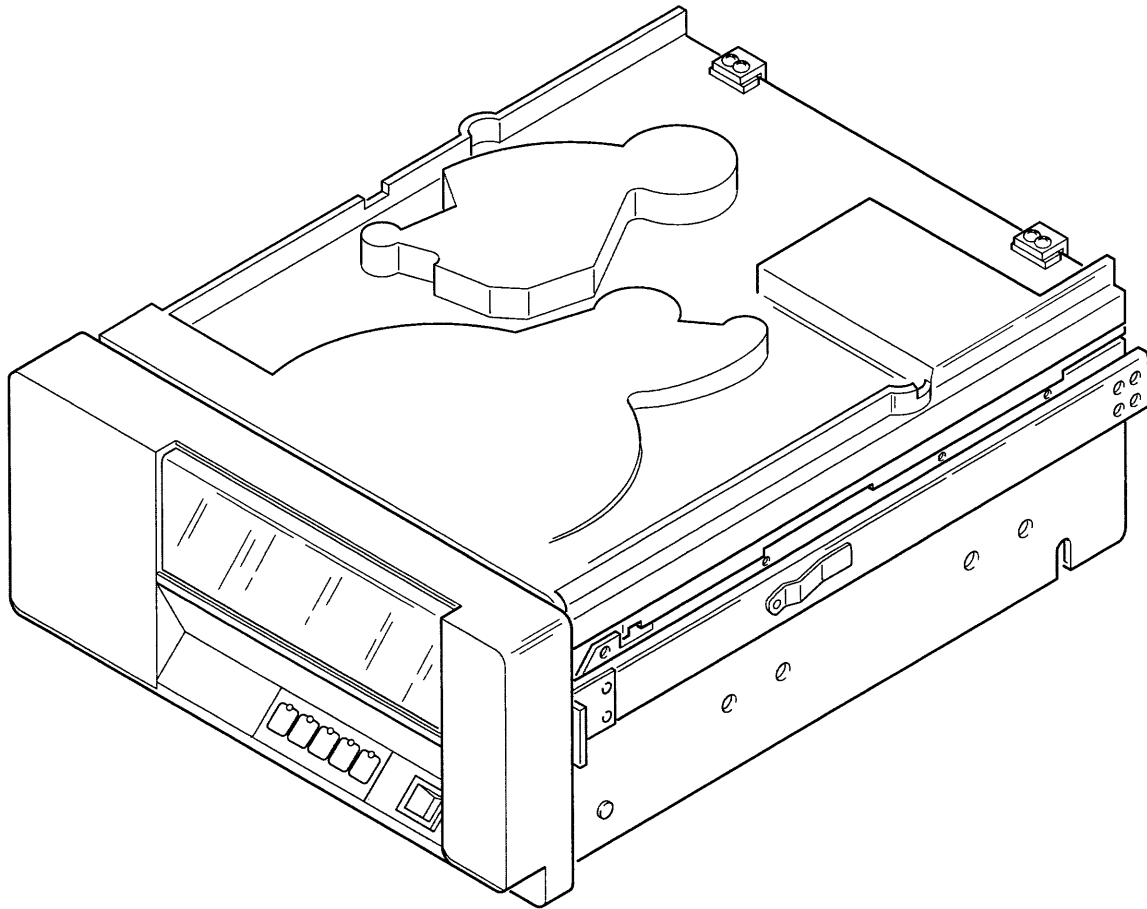

Figure 1-1. F880ES Rack-Mount Tape Drive

PHYSICAL DESCRIPTION

The F880ES tape drive consists of three main assemblies: the chassis, the deck plate, and the printed circuit board.

All components and subassemblies are mechanically fastened to a cast-aluminum deck plate, including two direct-drive dc motors with reel hubs, a power supply, the read/write head, sensors, the tension arm, and the front panel. The deck plate is mounted to hinges inside a metal chassis that encloses critical parts, as well as the printed circuit board, which contains all drive control circuitry and the SCSI interface. The drive's top cover protects the parts attached to the top of the deck plate, as well as the tape path and the tape.

Designed for mounting in a standard 19-inch RETMA equipment rack or a table-top enclosure, the drive is 8.75 inches high, 19 inches wide, and 22.7 inches deep and weighs 82 pounds. Slides for mounting the drive in a rack are included with drives that are not ordered with the optional enclosure.

TAPE PATH AND SERVICE ACCESS

Access is available to the tape path and to the internal components of the tape drive. Access to the tape path is often referred to as operator access, and to the internal components as service access. Throughout this manual it will be taken for granted that the reader is a trained, qualified technician who knows how to obtain access to the drive in both ways. The procedures are explained below.

Operator Access

Rack-Mounted Drive

1. Release the rack latch located under the left side of the front panel. See Figure 1-2.

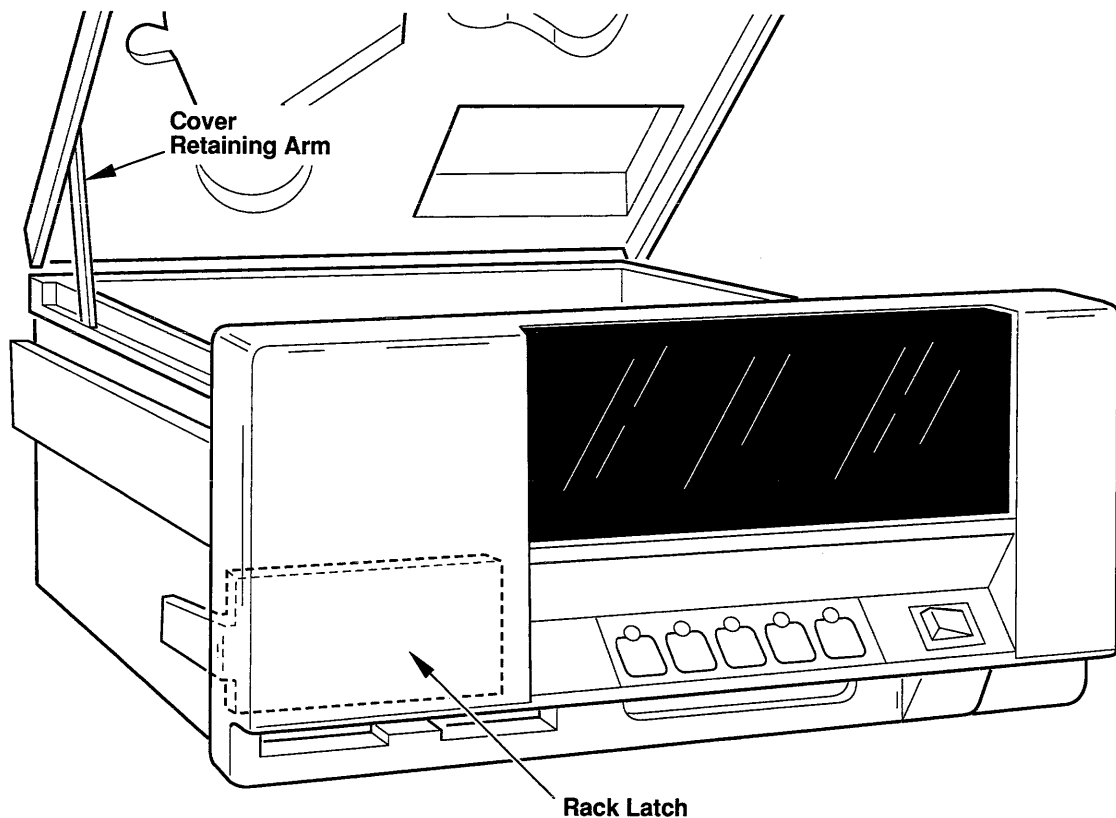

Figure 1-2. Location of Rack Latch and Cover Retainer Arm

2. Pull the tape drive out of the equipment rack.
3. Raise the top cover and place the cover retainer arm (Figure 1-2) in the slot next to the tape path.

Reinstall the tape drive in the rack as follows:

1. Close the top cover.
2. Press the slide locks inward and push the tape drive into the equipment rack.

Enclosed Drive

1. Open the lid of the enclosure fully. Push down on the front corners to release the catches before lifting the lid.
2. Raise the top cover and place the cover retainer arm (Figure 1-2) in the slot next to the tape path.

Close up the enclosure as follows:

1. Close the top cover of the tape drive.
2. Release the lid retainer arm on the right side of the enclosure lid and close the lid.

Service Access

Rack-Mounted Drive

1. Release the rack latch located under the left side of the front panel (Figure 1-2).
2. Pull the tape drive out of the equipment rack.
3. Raise the top cover and place the cover retainer arm (Figure 1-2) in the slot next to the tape path.
4. Loosen, but do not remove, the two screws on each side of the deck plate. See Figure 1-3.

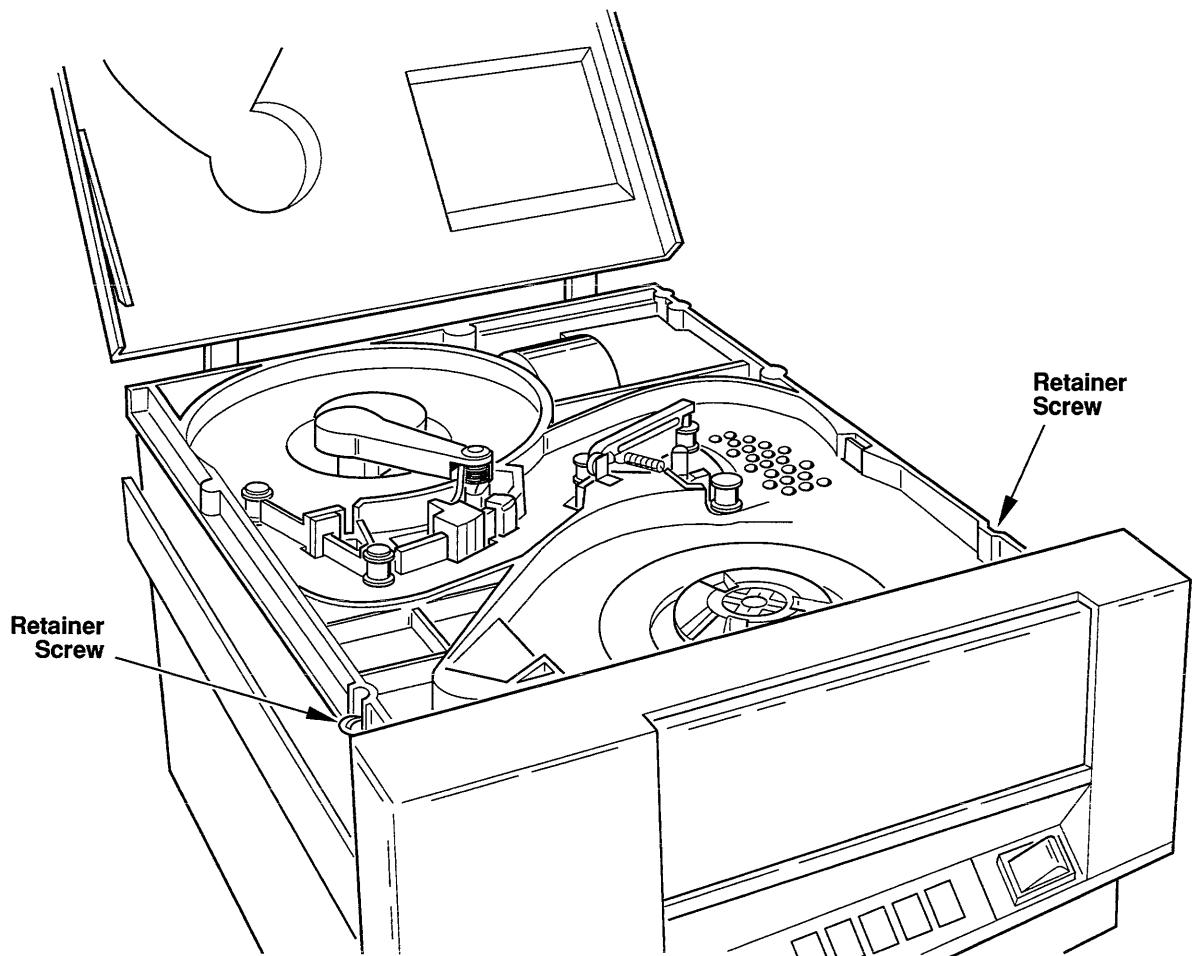

Figure 1-3. Location of Deck Plate Retainer Screws

5. Close the top cover.
6. Grasp the bottom of the front panel and lift it upward as far as it goes, then lower it slowly until the latch in the support arm locks.
7. Insert the safety pin into the hole in the support arm. See Figure 1-4.

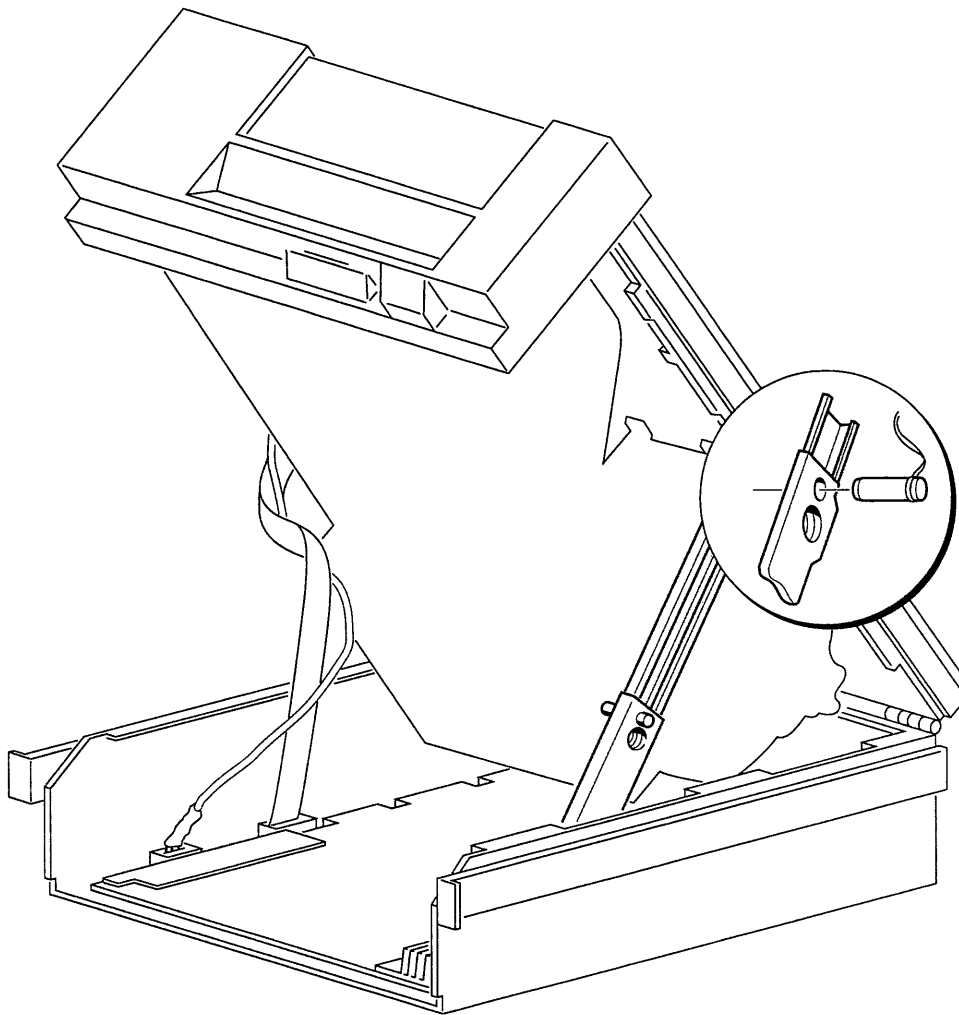

Figure 1-4. Inserting Safety Pin Into Support Arm

Reinstall the tape drive in the rack as follows:

1. Remove the safety pin from the support arm.
2. Grasp the bottom of the front panel and lift it upward to unlock the support arm latch, then lower it slowly.
3. Raise the top cover and place the cover retainer arm (Figure 1-2) in the slot next to the tape path.
4. Tighten the two screws on each side of the deck plate to secure it to the chassis.
5. Close the top cover.
6. Press the slide locks inward and push the tape drive into the equipment rack.

Enclosed Drive

1. Open the lid of the enclosure fully. Push down on the front corners to release the catches before lifting up the lid.
2. Raise the top cover and place the cover retainer arm (Figure 1-2) in the slot next to the tape path.
3. Loosen, but do not remove, the two screws on each side of the deck plate. See Figure 1-3.
4. Close the top cover.
5. Grasp the bottom of the front panel and lift it upward as far as it goes, then lower it slowly until the latch in the support arm locks.
6. Insert the safety pin into the hole in the support arm. See Figure 1-4.

Close up the enclosure as follows:

1. Remove the safety pin from the support arm.
2. Grasp the bottom of the front panel and lift it upward to unlock the support arm latch, then lower it slowly.
3. Raise the top cover and place the cover retainer arm (Figure 1-2) in the slot next to the tape path.
3. Tighten the two screws on each side of the deck plate to secure it to the chassis.
4. Close the top cover of the tape drive.
5. Release the lid retainer arm on the right side of the enclosure lid and close the lid.

PARTS LOCATIONS

Front View

Figure 1-5 shows the location of the major parts at the front of the tape drive.

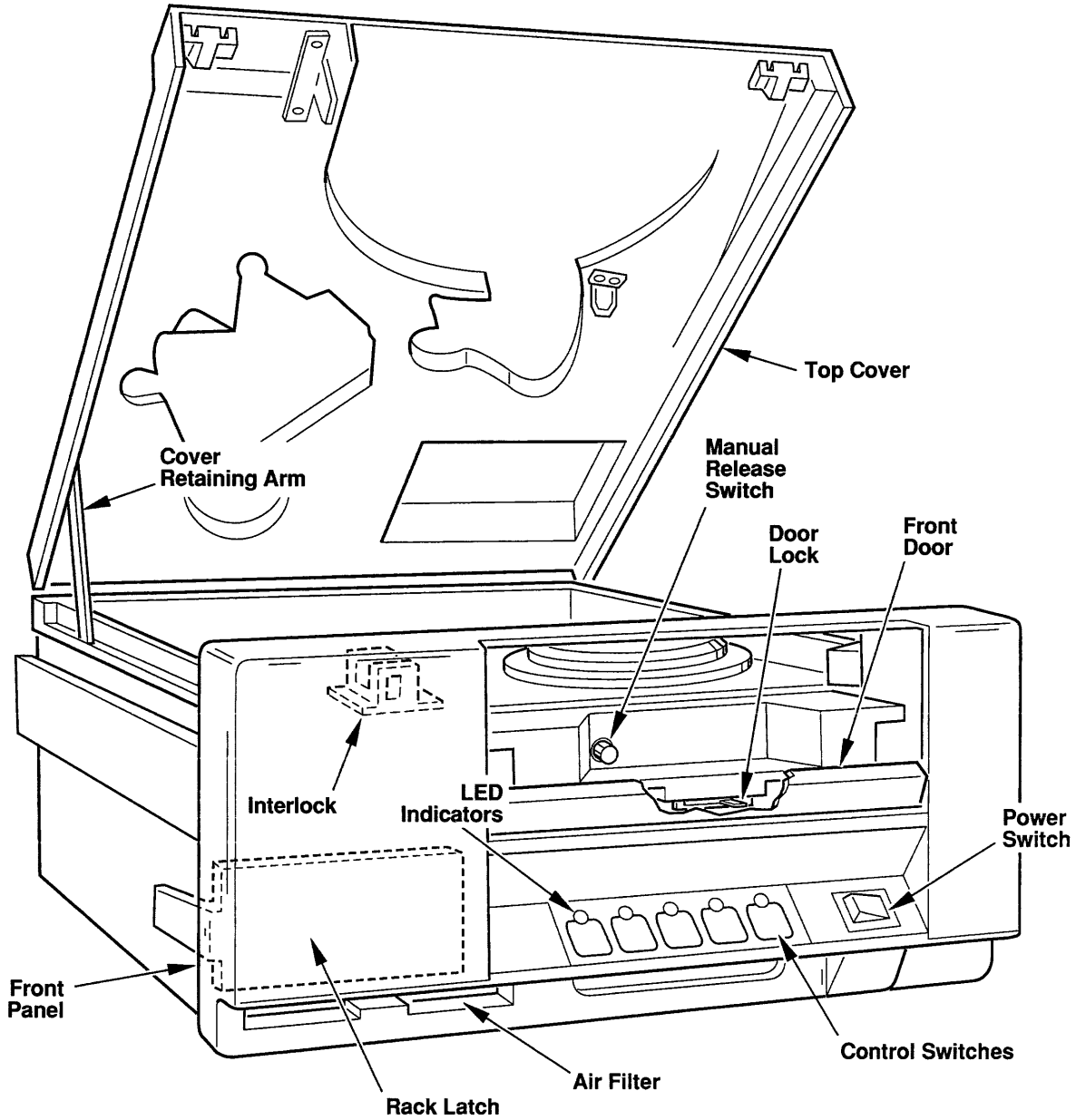

Figure 1-5. Front Parts

Rear View

Figure 1-6 shows the location of the major parts at the rear of the tape drive.

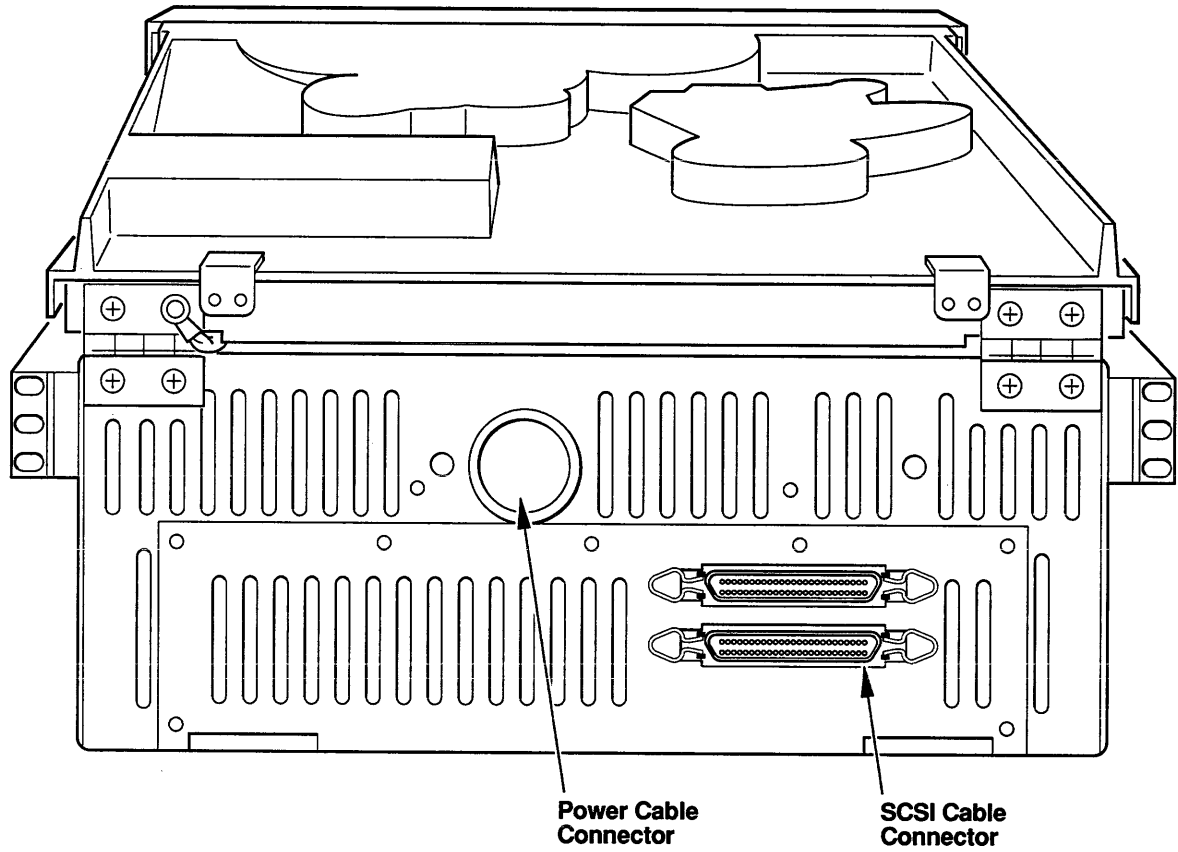

Figure 1-6. Rear Parts

Top View

Figure 1-7 shows the location of the major parts at the top of the tape drive.

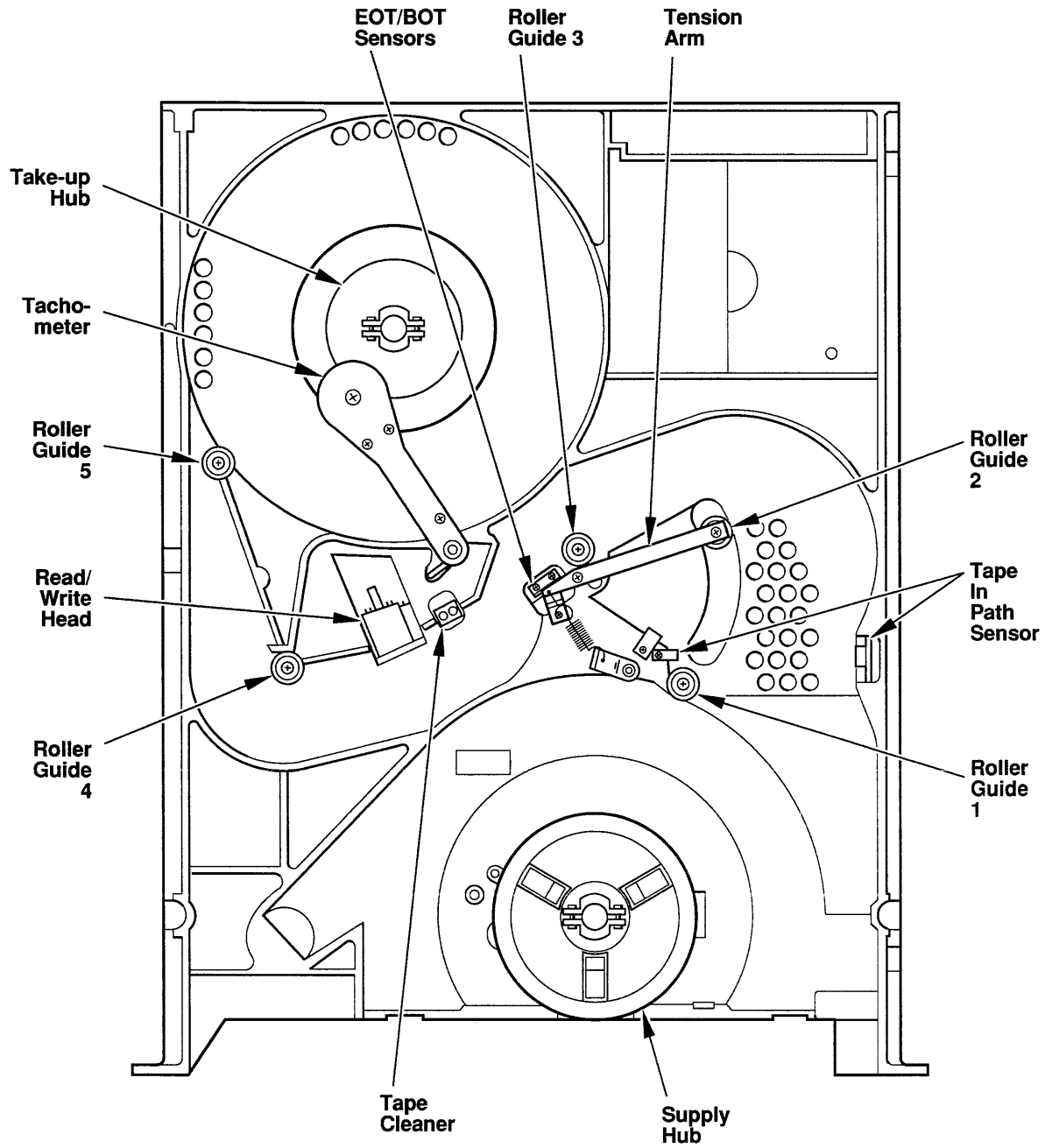

Figure 1-7. Top Parts

Bottom View

Figure 1-8 shows the location of the major parts at the bottom of the deck plate.

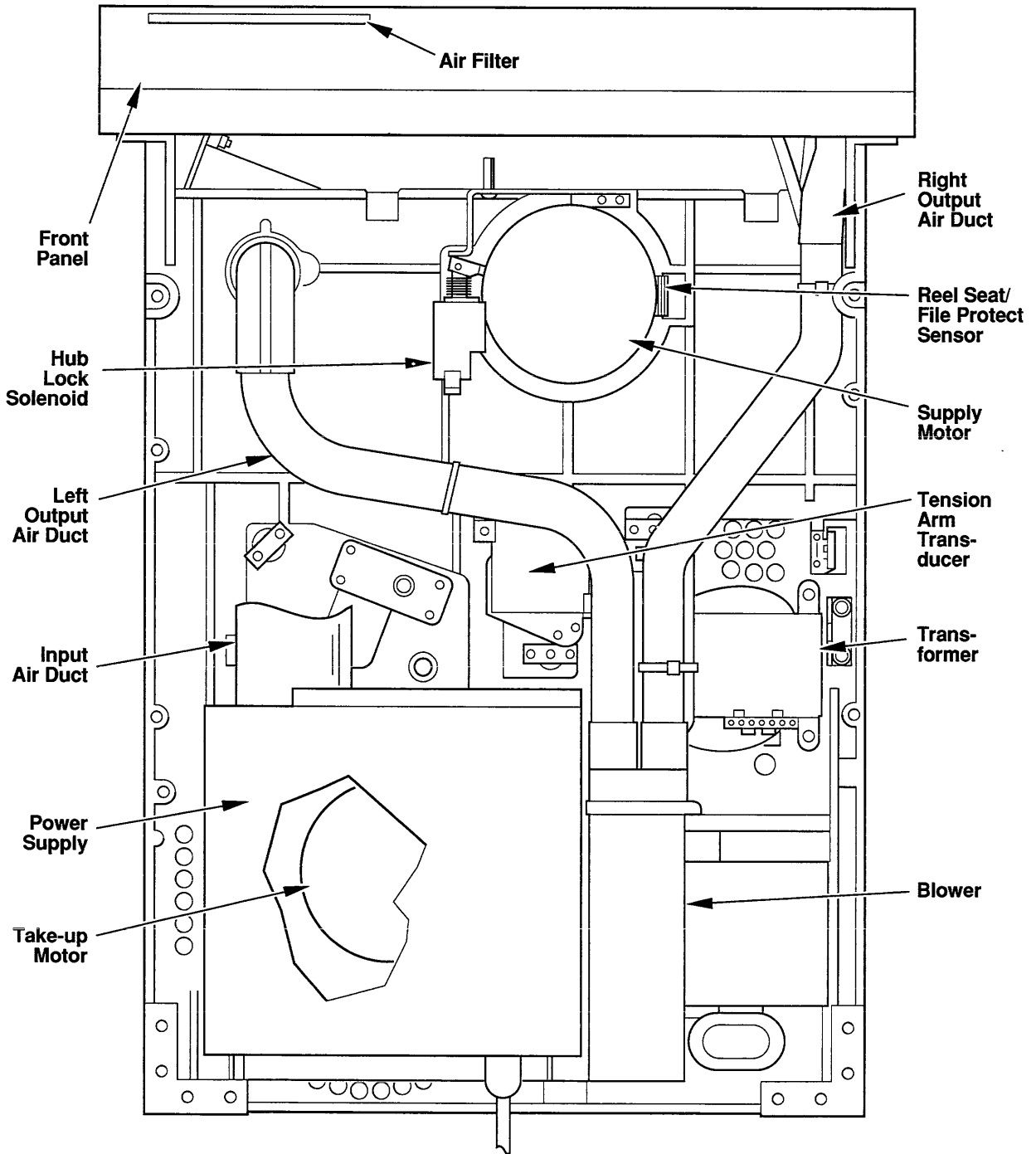

Figure 1-8. Bottom Parts

Chapter 2 **Installation and Configuration**

INTRODUCTION

This chapter describes how to unpack, install, and configure the F880ES tape drive.

UNPACKING

After removing the tape drive and all its accessories from the shipping carton, follow these instructions:

1. If any tape is securing the top cover and front panel door, remove it.
2. Raise the top cover and place the cover retainer bar in the slot next to the tape path.
3. Move the tachometer arm away from the take-up hub and remove the cushion from the hub. Place the tachometer arm against the hub gently.
4. Place the tape drive in the service access position.
5. Remove any packing material around the printed circuit board.
6. Close up the tape drive.

INSTALLATION

Rack Mounting

Refer to the drawing from the Hardware Installation Kit that came with the tape drive, to drawing 960264-000 at the back of this manual, and to Figure 2-1 while following this procedure:

1. Locate the front and rear rail holes of the cabinet or equipment rack where the drive will be installed. If they are threaded, drill them out to at least 0.281 inches.
2. Place the drive in the service access position.
3. Remove the stationary section (1) of each slide from the drive by pulling it forward.
4. Remove the intermediate section (2) each slide by pulling it to the rear of the drive. When the slides lock in the lock points, release them by depressing the lock tabs.
5. Place the drive back in the operating position.

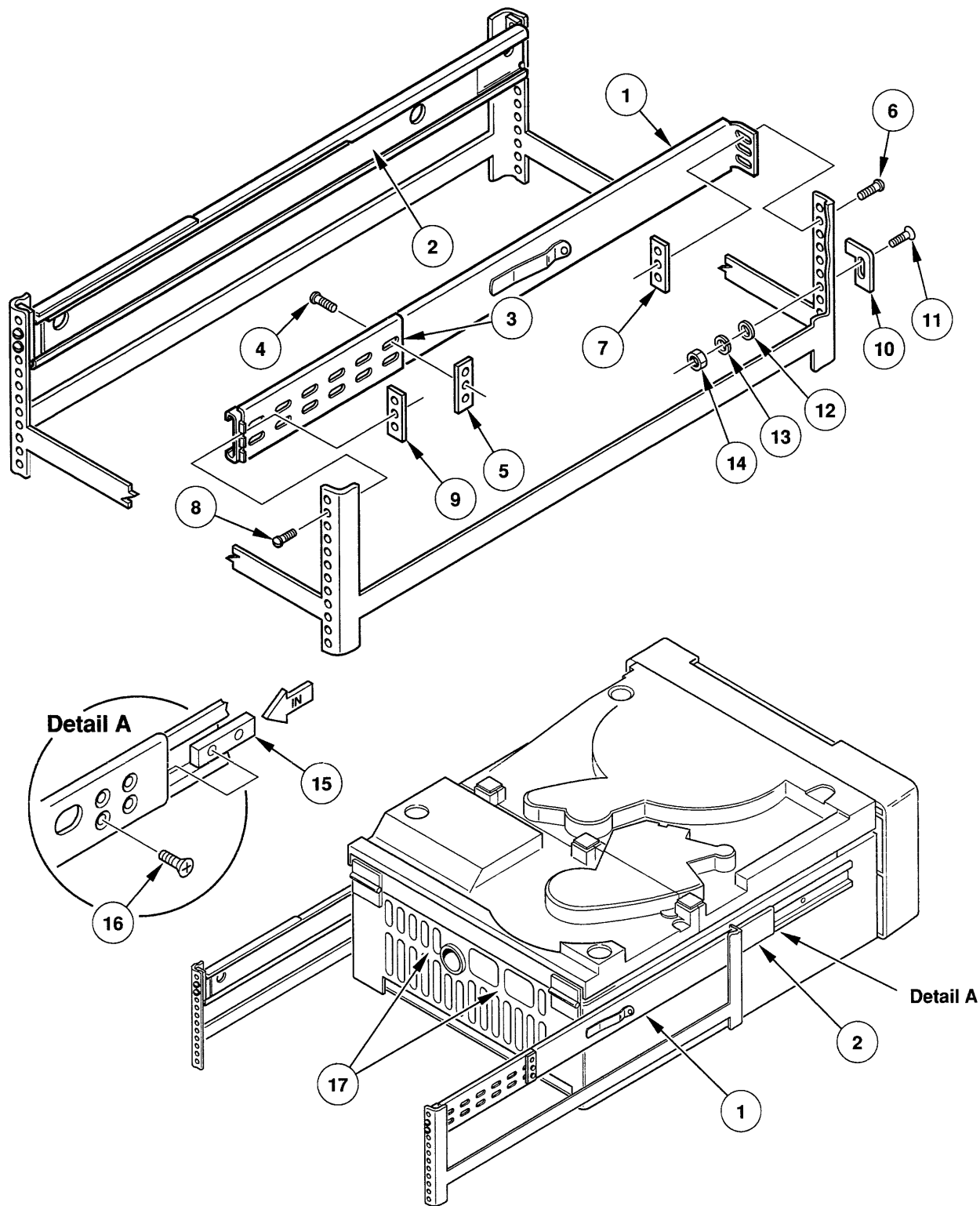

Figure 2-1. Rack Mount

6. Reassemble the stationary and intermediate sections by inserting the front of the intermediate section (front has hole further from end) into the rear of the stationary section. Depress the lock tab on each stationary section to fit the two sections together. Center the intermediate section inside the stationary section.
7. Loosely assemble each mounting bracket (3) to a stationary section using two screws (4) and a nut plate (5).
8. Loosely assemble the front and rear of each stationary section to the equipment rack or cabinet using two screws (6) and a nut plate (7).
9. Ensure the alignment of each slide is correct, then tighten the six screws for each slide.
10. Assemble the rack latch bracket (10) on the left rail (as you face the front of the rack or cabinet) so that the bottom edge is 2.13 inches below the centerline of the slide. Use two screws (11), flat washers (12), lock washers (13), and nuts (14) to secure it.
11. Slide the intermediate section of each slide out of the rack or cabinet so that it locks at the lock point of the stationary section.
12. Install the drive on the slides. The slide section mounted to the drive's chassis fits inside the intermediate section. The four lock tabs (two on each side at the rear of the chassis-mounted section) must be depressed to mate the slide sections together.
13. Check that the rack latch engages correctly.
14. Adjust the rack latch and slides as necessary so that both function smoothly.
15. Assemble a positive stop (15) to the front of each intermediate section of the slide using two screws (16). The stop mounts horizontally to the inside of the intermediate section at the two lower mounting holes.

WARNING

The positive stop is a critical safety device designed to prevent slide separation that could result in serious injury to personnel.

16. Connect the power cord. Be sure to provide a service loop using a cable clamp at either location (17) provided in the chassis.

Enclosure Installation

This section describes how to install the tape drive into a table-top enclosure. Refer to Figure 2-2 while following this procedure.

1. Lift open the enclosure lid. Push down on the front corners to release the catches before lifting up the lid.
2. Place the tape drive into the enclosure, with the front panel at the open end of the enclosure.
3. Open the tape drive to the service access position.
4. Remove the main circuit board as explained in Chapter 6.
5. Move the tape drive in the enclosure so the two holes in the front of the chassis (1) and the two slots at the rear of the chassis (2) align with the four nuts (3) in the bottom of the enclosure.
6. Secure the chassis in the enclosure using four screws (4) with washers. Align the front panel so that the gaps between it and the enclosure are equal.

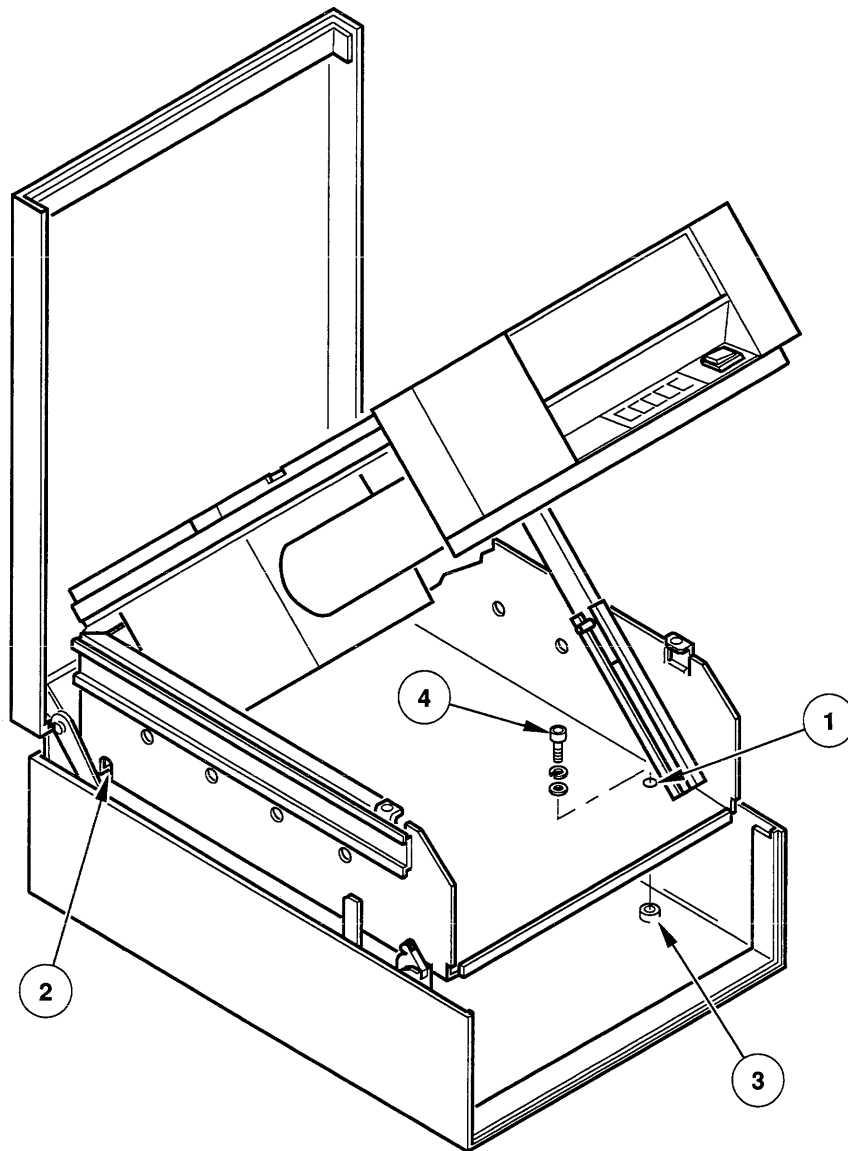

Figure 2-2. Installation into an Enclosure

7. Reinstall the main circuit board in the tape drive.
8. The recommended routing for the SCSI cable is through the rectangular opening in the lower right side of the back of the enclosure. See Figure 2-3. The rear panel of the enclosure comes off by removing six screws.
9. Route the power cord through either opening in the bottom rear of the enclosure. Be sure to provide a service loop using a cable clamp at either location (17 of Figure 2-1) provided in the chassis.

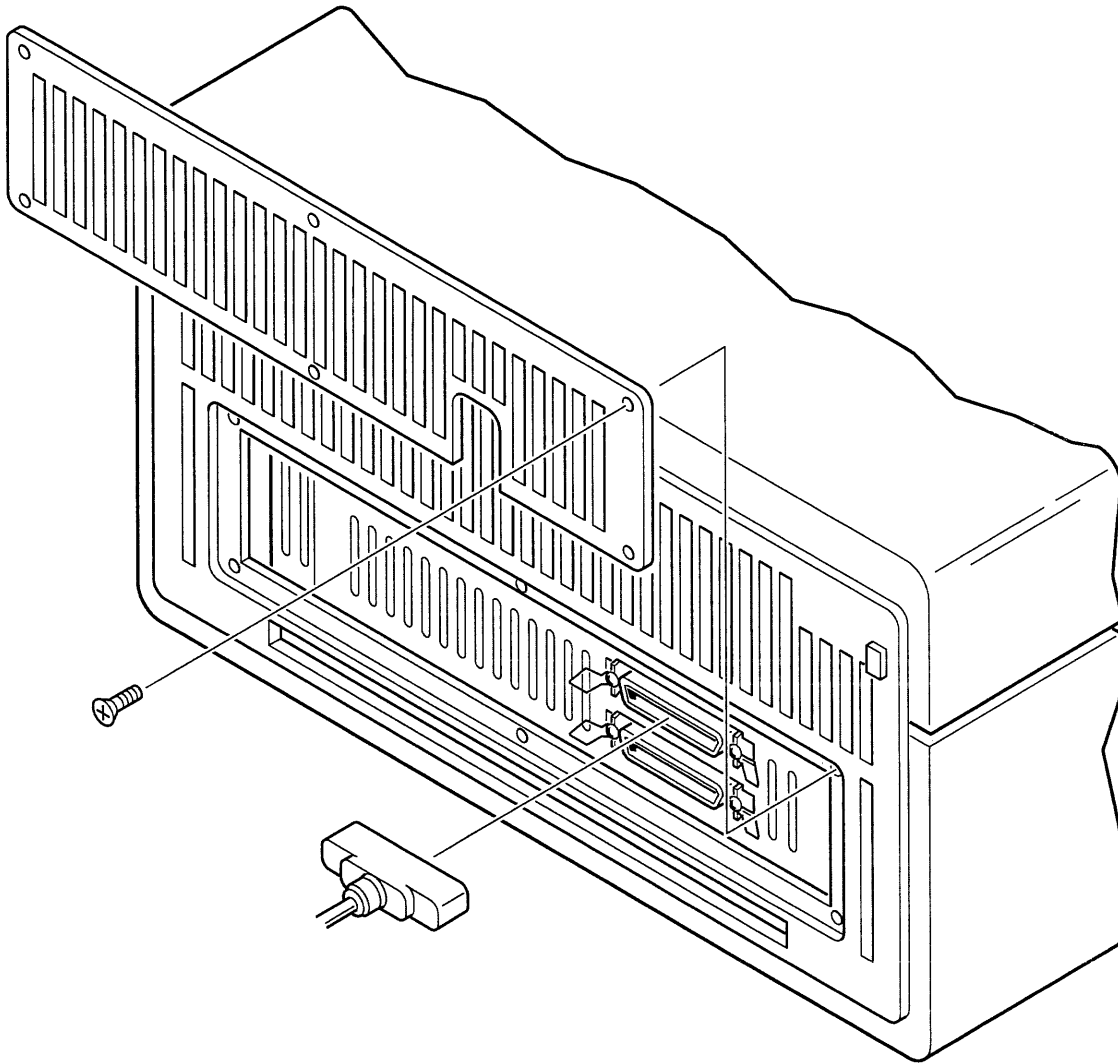

Figure 2-3. Installation of a SCSI Cable in an Enclosure

AC Voltage Selection

The manufacturer's label on the back of the drive specifies the voltage that the drive is set to use and that the power cord is designed for.

An ac voltage selection circuit board inside the power supply allows the drive to utilize input voltages ranging from 100 to 240 volts. A fuse in the power supply housing may need to be changed depending on the voltage selected. Use the following procedure to change the voltage selection board and the fuse.

1. Be sure the power switch is off and the power cord is not connected to an outlet.
2. Open the drive to the service access position.

3. Remove the two screws (1) that secure the power supply cover (2) to the power supply housing and remove the power supply cover. See Figure 2-4.

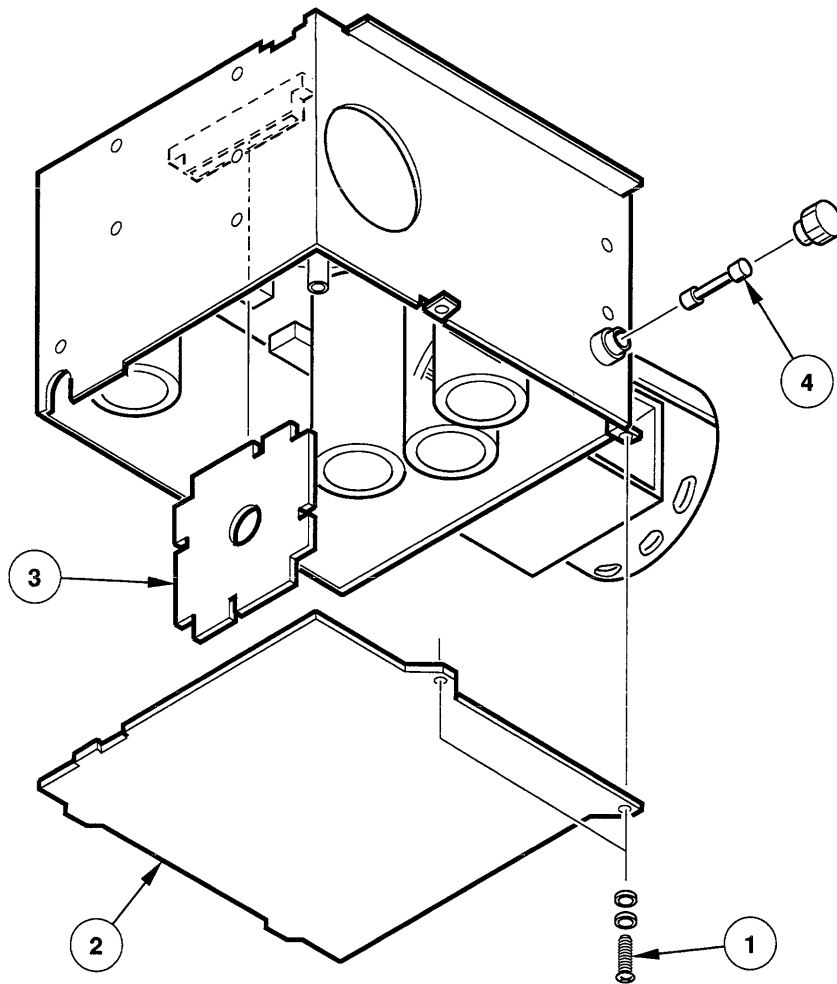

Figure 2-4. Location of Voltage-Select Circuit Board and Fuse

4. Remove the voltage selection board (3) from its connector on the power supply circuit board. Reinstall it to select the desired ac operating voltage. See Table 2-1.

Voltage Rating	Selection Board	Fuse (Amps)	Frequency (Hertz)
100	100	3.0	49-61
115/120	120	3.0	49-61
208/220	220	1.5	49-61
230/240	240	1.5	49-61

Table 2-1. AC Voltage Selection

5. Reinstall the power supply cover.
6. Replace the fuse (4) if required; use a slow-blow 250-volt fuse. Refer to Table 2-1 for the amperage. Replace the power cord if necessary.

CAUTION

This unit relies on 16 ampere (maximum) building installation fusing for protection.

Interface Cable

The ideal impedance match with cable terminators is 132 ohms. A characteristic impedance of 100 ohms ± 10 percent is recommended for unshielded flat or twisted-pair cables; a characteristic impedance greater than 90 ohms is preferred for shielded cables. Cables of different impedances should not be used. A minimum conductor size of 28 AWG is required. Twisted-pair cable must not have less than one twist per inch. Each end of the twisted pair ground wire must be connected to chassis ground.

Single-Ended

A 50-conductor flat cable or 25-signal twisted-pair cable is required. The maximum cable length is six meters. Table 2-2 provides the pin assignments for the single-ended unshielded and Alternative 1 connector. Table 2-3 provides the pin assignments for the single-ended Alternative 2 shielded connector. Proper termination of all signals is shown Figure 2-5.

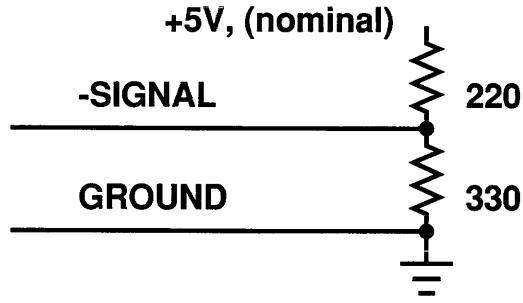

Figure 2-5. Termination for Single-Ended Devices

Differential

A 50-conductor flat cable or 25-signal twisted-pair cable is required. The maximum cable length is 25 meters. Table 2-4 provides the pin assignments for the differential Alternative 1 connector. Table 2-5 provides the pin assignments for the differential Alternative 2 shielded connector. Proper termination of all signals is shown Figure 2-6.

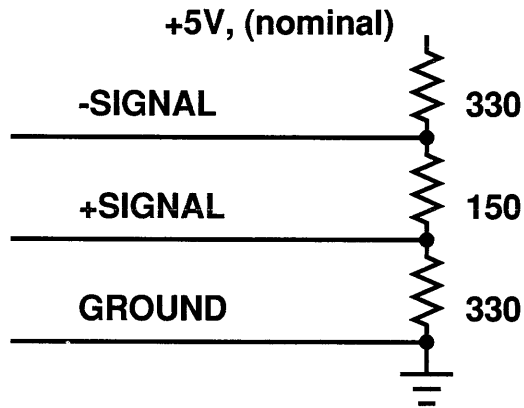

Figure 2-6. Termination for Differential Devices

Signal	Pin Number
-DB(0)	2
-DB(1)	4
-DB(2)	6
-DB(3)	8
-DB(4)	10
-DB(5)	12
-DB(6)	14
-DB(7)	16
-DB(P)	18
Ground	20
Ground	22
Ground	24
TERMPWR	26
Ground	28
Ground	30
-ATN	32
Ground	34
-BSY	36
-ACK	38
-RST	40
-MSG	42
-SEL	44
-C/D	46
-REQ	48
-I/O	50

Note: All odd pins except 25 are connected to ground. Pin 25 should be open.

Table 2-2. Single-Ended Unshielded and Alternative 1 Pin Assignments

Signal	Pin Number
-DB(0)	26
-DB(1)	27
-DB(2)	28
-DB(3)	29
-DB(4)	30
-DB(5)	31
-DB(6)	32
-DB(7)	33
-DB(P)	34
Ground	35
Ground	36
Ground	37
TERMPWR	38
Ground	39
Ground	40
-ATN	41
Ground	42
-BSY	43
-ACK	44
-RST	45
-MSG	46
-SEL	47
-C/D	48
-REQ	49
-I/O	50

Note: Pins 1-12 and 14-25 are connected to ground. Pin 13 should be open.

Table 2-3. Single-Ended Alternative 2 Pin Assignments

Signal	Pin Number		Signal
Shield Ground	1	2	Ground
+DB(0)	3	4	-DB(0)
+DB(1)	5	6	-DB(1)
+DB(2)	7	8	-DB(2)
+DB(3)	9	10	-DB(3)
+DB(4)	11	12	-DB(4)
+DB(5)	13	14	-DB(5)
+DB(6)	15	16	-DB(6)
+DB(7)	17	18	-DB(7)
+DB(P)	19	20	-DB(P)
DIFFSENS	21	22	Ground
Ground	23	24	Ground
TERMPWR	25	26	Ground
Ground	27	28	Ground
+ATN	29	30	-ATN
Ground	31	32	Ground
+BSY	33	34	-BSY
+ACK	35	36	-ACK
+RST	37	38	-RST
+MSG	39	40	-MSG
+SEL	41	42	-SEL
+C/D	43	44	-C/D
+REQ	45	46	-REQ
+I/O	47	48	-I/O
Ground	49	50	Ground

Table 2-4. Differential Alternative 1 Pin Assignments

Signal	Pin Number		Signal
Shield Ground	1	26	Ground
+DB(0)	2	27	-DB(0)
+DB(1)	3	28	-DB(1)
+DB(2)	4	29	-DB(2)
+DB(3)	5	30	-DB(3)
+DB(4)	6	31	-DB(4)
+DB(5)	7	32	-DB(5)
+DB(6)	8	33	-DB(6)
+DB(7)	9	34	-DB(7)
+DB(P)	10	35	-DB(P)
DIFFSENS	11	36	Ground
Ground	12	37	Ground
TERMPWR	13	38	Ground
Ground	14	39	Ground
+ATN	15	40	-ATN
Ground	16	32	Ground
+BSY	17	34	-BSY
+ACK	18	36	-ACK
+RST	19	38	-RST
+MSG	20	40	-MSG
+SEL	21	42	-SEL
+C/D	22	44	-C/D
+REQ	23	46	-REQ
+I/O	24	48	-I/O
Ground	25	50	Ground

Table 2-5. Differential Alternative 2 Pin Assignments

CONFIGURATION

Configuring the tape drive consists of setting the SCSI ID, the bus termination, and various options.

Switch 1 of U2C resets the SCSI microprocessor. The normal position is open/off.

Switches 2 to 5 of U2C are for depot testing and must be closed/on.

SCSI ID

The tape drive requires a unique SCSI ID, that is, an ID that no other device on the bus has. DIP switch U2C, whose location on the main circuit board is shown in Figure 2-7, sets the SCSI ID. Table 2-6 shows how to set switches 6, 7, and 8 of U2C to obtain the desired SCSI ID.

6	7	8	SCSI ID
Open/Off	Open/Off	Open/Off	0
Closed/On	Open/Off	Open/Off	1
Open/Off	Closed/On	Open/Off	2
Closed/On	Closed/On	Open/Off	3*
Open/Off	Open/Off	Closed/On	4
Closed/On	Open/Off	Closed/On	5
Open/Off	Closed/On	Closed/On	6
Closed/On	Closed/On	Closed/On	7

An asterisk (*) indicates the factory setting.

Table 2-6. SCSI ID Switch Settings

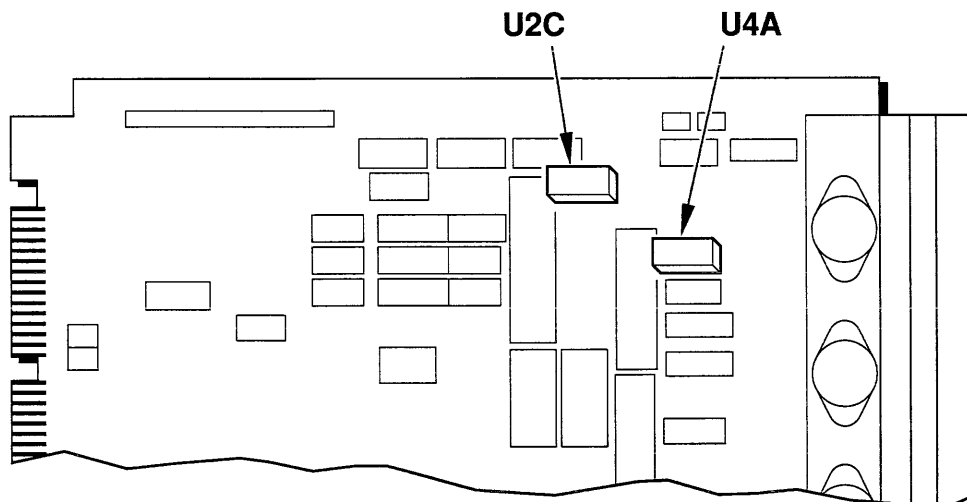

Figure 2-7. DIP Switches U2C and U4A

Configuration Options

A number of configuration options are available. DIP switch U4A, whose location on the main circuit board is shown in Figure 2-7, sets the options; Table 2-7 provides a list of the available options available with U4A and how to select them.

Switch	Position	Function
1	Closed/On* Open/Off	Enable arbitration Disable arbitration
2	Closed/On* Open/Off	Enable SCSI parity checking Disable SCSI parity checking
3, 4	Closed/On*, Closed/On*	Reserved
5, 6	Closed/On*, Closed/On* Closed/On, Open/Off Open/Off, Closed/On Open/Off, Open/Off	Normal Loop on power-up routines Loop on RAM data dump Allow command execution after power-up failure
7	Closed/On*	Reserved
8	Closed/On* Open/Off	Defines response to a Test Unit Ready command following a Rewind Immediate: Not Ready response Good response

An asterisk (*) indicates the factory setting.

Table 2-7. Configuration Options, DIP Switch U4A

Bus Terminator

A bus terminator must be at each end of the SCSI bus. If the tape drive is at either physical end of the bus, a terminator plug must be installed in the unused SCSI cable connector at the rear of the drive. See Figure 2-8. If the tape drive is not at either end of the bus, the terminator plug must be removed.

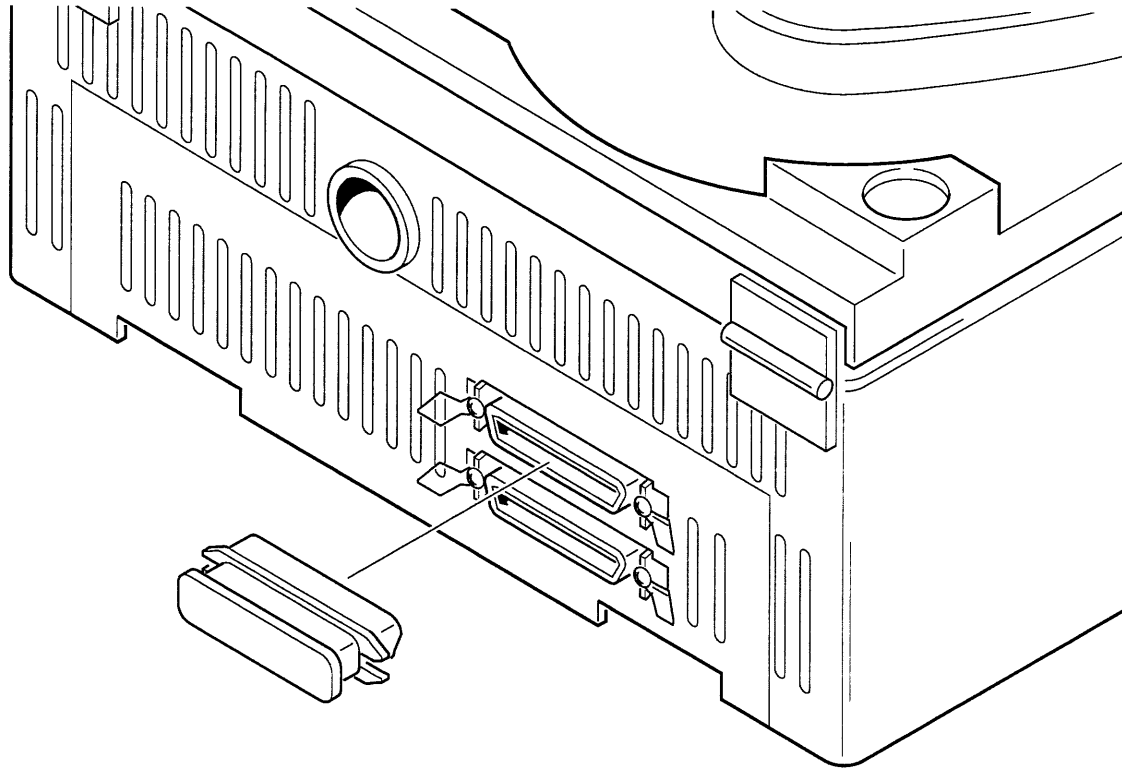

Figure 2-8. Installation of Terminator Plug

Chapter 3 Operation

INTRODUCTION

This chapter explains how to operate the tape drive, including how to load and unload tape.

CAUTION

If the tape drive is on and the top cover is opened, the tape drive is shut down; this could cause data on the SCSI bus to be corrupted.

FRONT PANEL

Figure 3-1 shows the switches and indicators of the front panel.

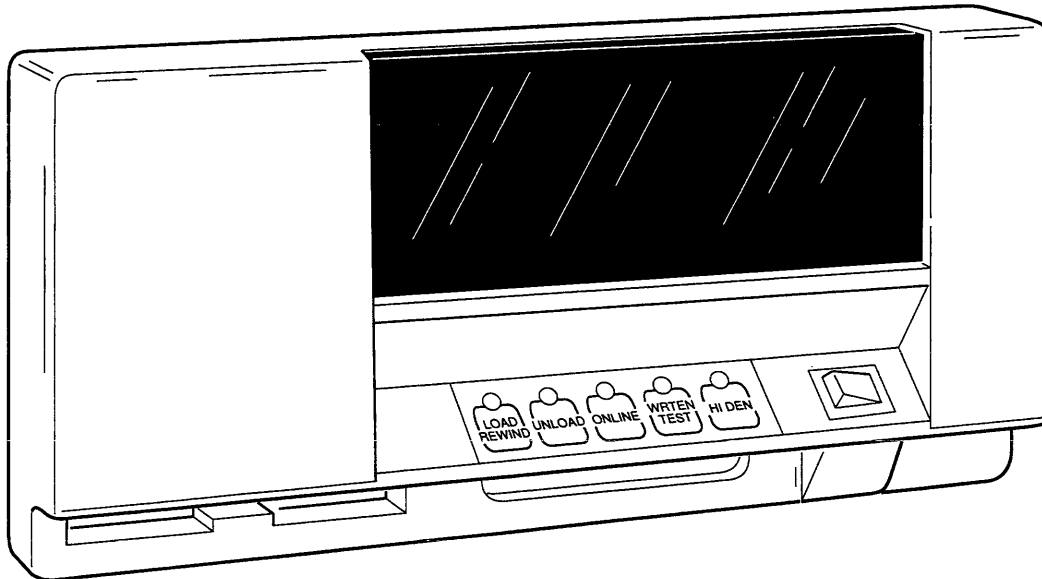

Figure 3-1. Front Panel

LOAD/REWIND

This switch causes the drive to thread tape and position it at BOT, or, when a tape is already loaded, to rewind it to BOT. The indicator above the switch flashes while the tape is loading or rewinding, then stays lit when either operation completes.

UNLOAD

This switch causes the drive to unload tape. The indicator above the switch flashes while the tape is unloading, then stays lit when the unload completes.

ON-LINE

This switch places the drive on-line and causes the indicator above the switch to turn on. If the drive is already on-line, this switch takes the drive off-line and turns off the indicator.

WRT EN/TEST

The WRT EN (Write Enable) indicator lights when a tape reel with a write-enable ring is loaded.

The TEST switch causes the drive to enter the diagnostic mode; it functions only when the drive is off-line. If the drive is already in the diagnostic mode, this switch causes it to exit the diagnostic mode and enter the operating mode.

HI DEN

The High Density (HI DEN) switch selects the operating density; it functions only when the drive is off-line and tape is loaded at BOT. When the 3200 density is selected, the indicator is lit; when the 1600 density is selected, the indicator is off.

A tape written at 3200 bpi cannot be read unless high density is selected, either using the HI DEN switch or from a host through the interface.

Power Switch

The power switch controls ac power to the drive. The switch is labelled with a "1" to indicate on and a "0" to indicate off. Whenever the power switch is in the on position, a light inside the switch causes it to glow.

When the power switch is pressed to on, the drive executes a series of power-up diagnostics. After the diagnostics are run, the UNLOAD indicator comes on showing that the drive is ready to have tape loaded.

The top cover and the front panel must both be closed whenever the power switch is pressed on, or else the drive does not power up.

LOADING TAPE

The drive does not load tape unless the UNLOAD indicator is on.

1. If required, prepare the tape leader using a tape cutter/crimper (209990-500) tool.
2. If data will be written to the tape, install a write-enable ring on the tape reel.
3. Check that the tape is wound completely onto the reel.
4. Open the front panel door by pressing down gently on its top.
5. Place the tape reel on the supply hub with write-enable ring side of the reel down. The reel must lie evenly on the hub.
6. Close the front panel door.
7. Press the LOAD/REWIND switch. The front panel door locks. When the drive finishes loading the tape, the LOAD indicator stays lit. The WRT EN indicator lights if a write-enable ring is installed.

Manual Load

If the drive cannot autoloading a reel of tape, the operator may use the following manual load procedure. Check that none of the indicators are flashing before loading tape manually.

CAUTION

Switching off tape drive while the system is operating could cause data on the SCSI bus to be corrupted. Halt the system before performing this procedure.

1. Press the power switch to off.
2. Open the drive to the operator access position.

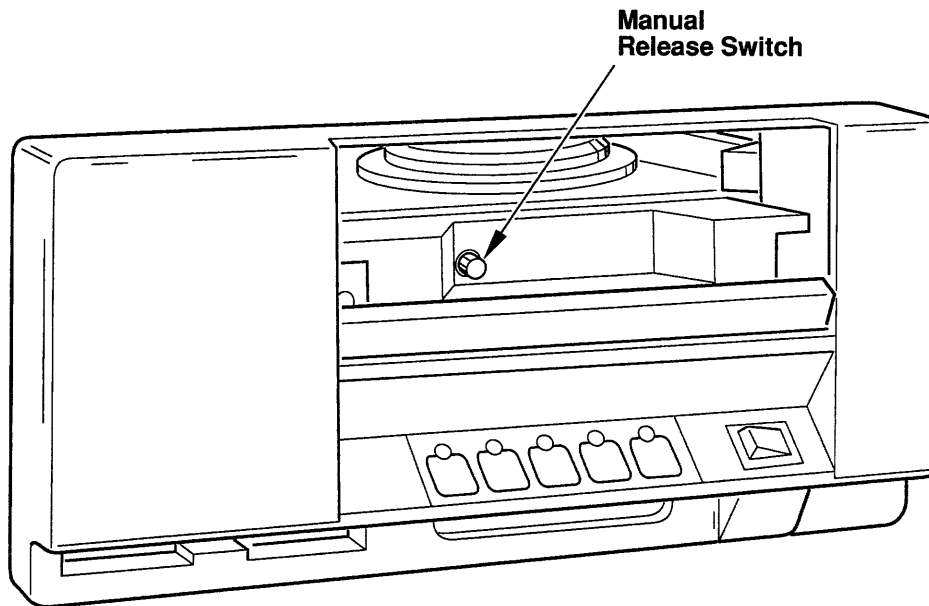

Figure 3-2. Location of Manual Release Switch

3. Place the tape reel on the supply hub with the write-enable ring side of the reel down. The reel must lie evenly on the hub.
4. Press the manual release switch, located behind the front panel door on the bottom left side (see Figure 3-2), and simultaneously rotate the supply hub clockwise until the tape reel locks in place.
5. Thread the tape along the path shown in Figure 3-3. Move the tachometer arm away from the take-up hub carefully, wrap the tape clockwise around the take-up hub until the end of the tape is held by the next layer, then turn the hub clockwise five revolutions. Gently place the tachometer arm back against the hub.

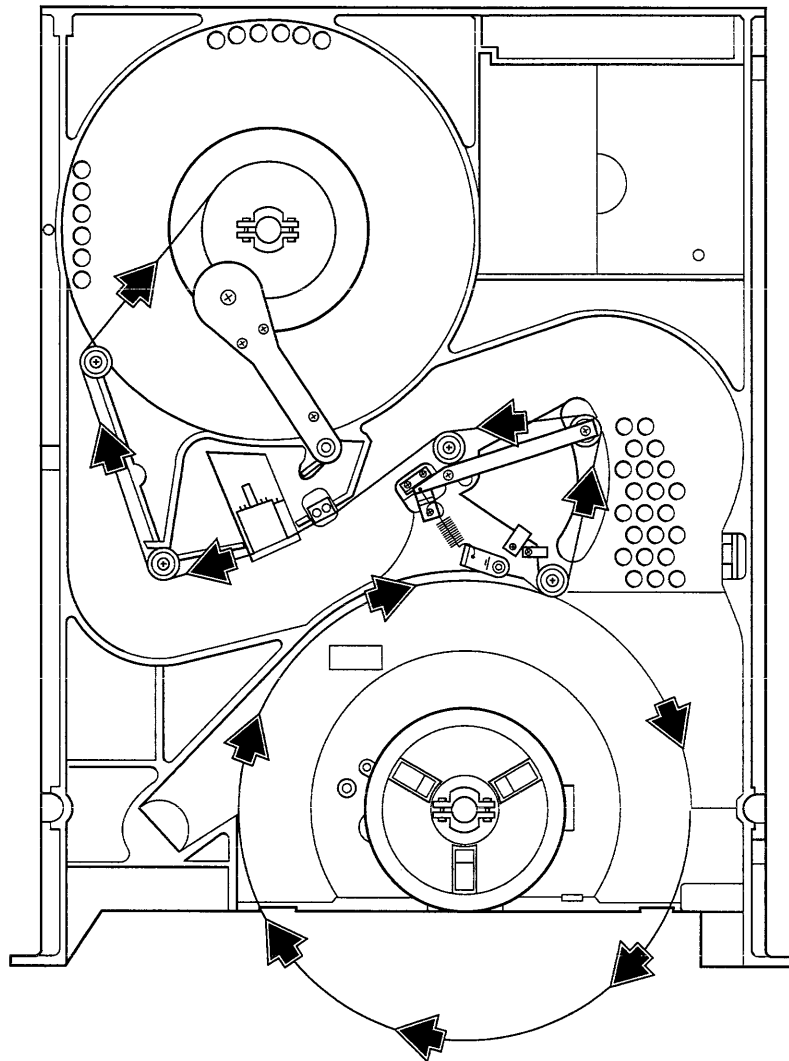

Figure 3-3. Tape Path

6. Check that the tape is seated correctly on the tape guides and the read/write head.
7. Close the top cover and the front panel door. Press and hold the lock buttons on each slide and push the drive back into the cabinet.
8. Press the power switch to on. Wait for the UNLOAD indicator to go on.
9. While pressing the HI DEN switch, press the LOAD switch; then release both. The drive loads the tape to BOT (The BOT marker is positioned at the BOT sensor.). The LOAD indicator stays lit, indicating the drive is ready.

UNLOADING TAPE

1. Check that the ON-LINE indicator is off (if not, press the ON-LINE switch) and that front panel door is closed.
2. Press UNLOAD switch. The UNLOAD indicator flashes while the drive is unloading the tape.
3. Open front panel door when the UNLOAD indicator stops flashing and stays lit continuously.
4. Remove the tape reel. If the tape reel cannot be removed, try the "Manual Unload" procedure that follows.

Manual Unload

If the drive does not unload a reel of tape, the operator may use the following manual unload procedure. Check that none of the indicators are flashing before unloading tape manually.

CAUTION

Switching off tape drive while the system is operating could cause data on the SCSI bus to be corrupted. Halt the system before performing this procedure.

1. Press the power switch to off.
2. Open the drive to the operator access position.
3. Rotate the supply reel counterclockwise to rewind the tape onto the supply reel.
4. Press the manual release switch, located behind the front panel door on the bottom left side (Figure 3-2), and simultaneously rotate the supply hub counterclockwise until the tape reel rotates freely and can be removed from the drive.

Chapter 4 Maintenance

INTRODUCTION

This chapter explains how to perform all required preventive maintenance on the tape drive.

TAPE PATH

All components of the tape path should be cleaned every 40 hours or weekly, whichever occurs first, except for the read/write head, which should be cleaned every 20 hours. Only Freon TF should be used as a cleaning agent, and it should be applied with a lintless swab or wipe. A Cleaning Kit is available from Cipher.

CAUTION

Do not apply a cleaner directly to the item to be cleaned, even if the instructions on the cleaner state to do so. Always apply the cleaner to a swab or wipe first. Cleaning agents can dissolve the lubricants in precision bearings.

Figure 4-1 shows the location of the components of the tape path that require cleaning:

- Tape cleaner
- Read/write head
- Tachometer roller
- Take-up hub
- All roller guides

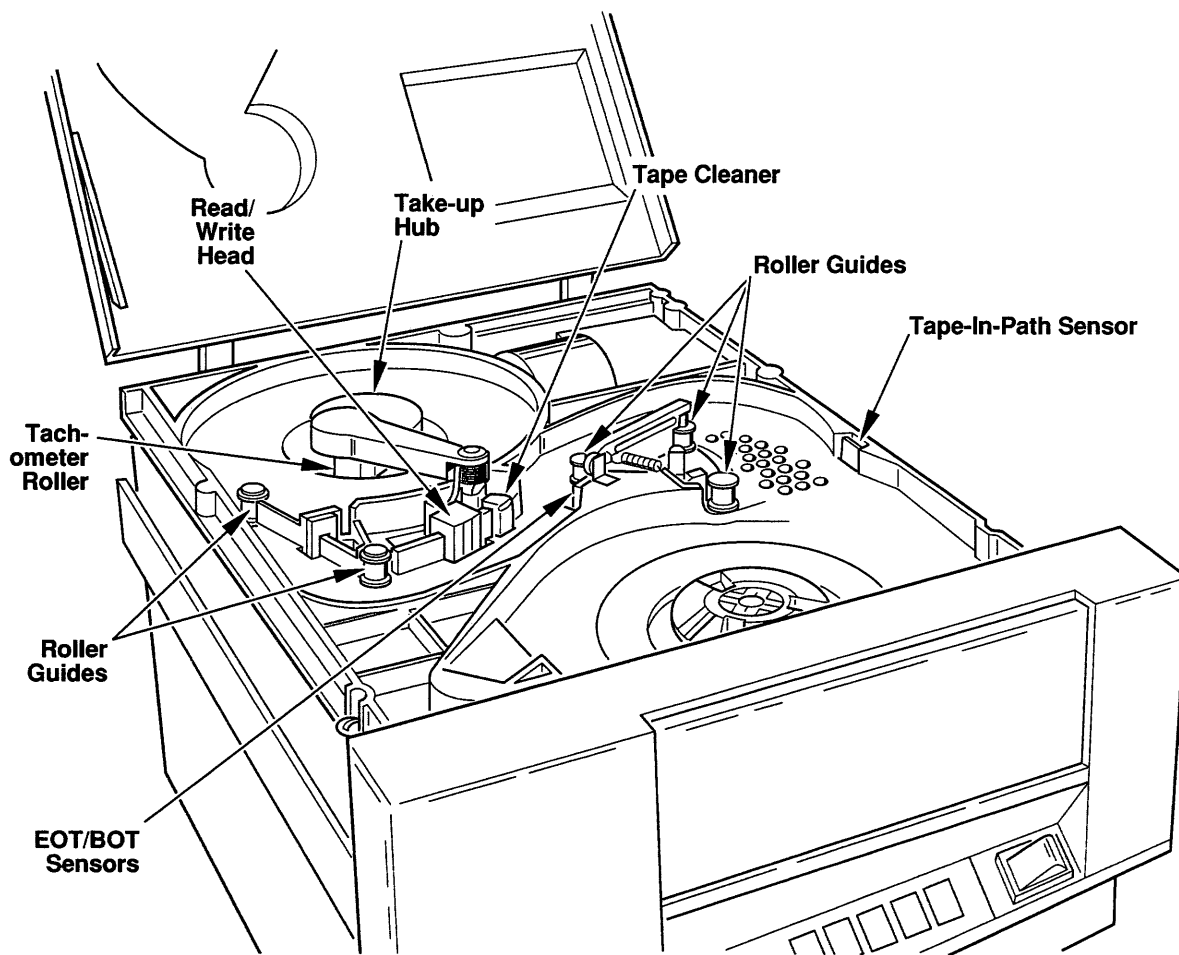

Figure 4-1. Tape Path and Sensors

SENSORS

The EOT, BOT, and the Tape-In-Path Sensors should be cleaned every 40 hours or weekly, whichever occurs first. Use a dry cotton swab to gently wipe any dust off the face of each LED lens, both the transmitter and the receiver. Wipe as gently as possible, as the alignment of the LEDs is critical. Figure 4-1 shows the location of the sensors

FILTER

The air filter should be clean every six months by blowing compressed air or vacuuming in the opposite direction of airflow. Figure 4-2 shows the location of the air filter in the lower left of the front panel.

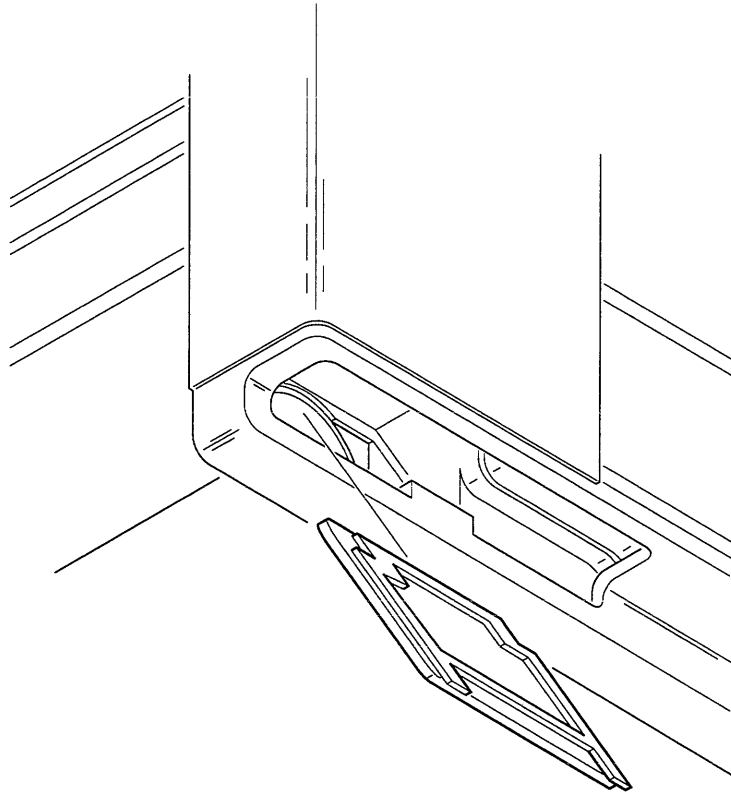

Figure 4-2. Air Filter

Chapter 5 Troubleshooting

INTRODUCTION

The drive communicates errors via the front panel, which displays various patterns on the LED indicators, and the SCSI interface. There are two types of errors: tape processing errors and tape drive faults. This chapter is divided into three sections. The "Errors" section describes the various errors and faults displayed by the indicators on the front panel. The "SCSI Diagnostic Functions" section describes the information provided through the SCSI interface. The "Drive Diagnostics" section explains how to use the drive's the diagnostic capabilities for troubleshooting hardware problems, including SCSI controller hardware failures.

ERRORS

Error Reporting

The drive reports error codes using the LEDs on the front panel. The error codes are transmitted as binary numbers with the LOAD/REWIND indicator as the least significant bit and the HI DEN indicator as the most significant bit. See Figure 5-1.

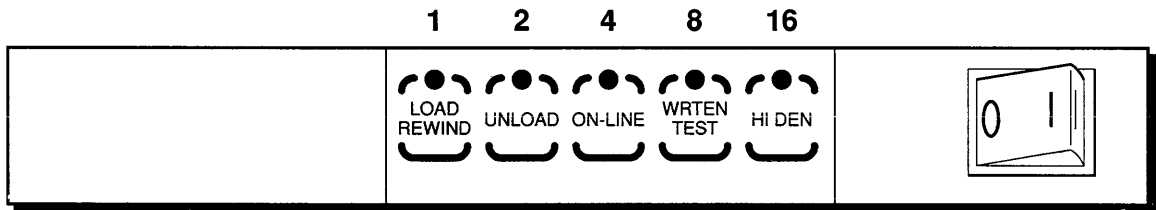

Figure 5-1. Bit Significance of Front Panel Indicators

For example, an Error Code 6, which indicates that the drive received a write command while a write-protected tape was loaded, causes the UNLOAD and ON-LINE indicators to flash.

Error Codes

Table 5-1 identifies each error code by the pattern displayed by the indicators. A "1" equals on and a "0" equals off.

Indicator Pattern	Error Code	Description
11000	3	More than 3700 feet of tape beyond BOT.
00100	4	Tension arm swing exceeded normal range during load or unload.
10100	5	Command received before previous command completed.
01100	6	Write command received for write-protected tape.
11100	7	Illegal command.
00010	8	Supply hub locking mechanism failure.
01010	10	Auto-zero of DAC failed during power-up.
11010	11	Servo circuit output test failed.
00110	12	Reel not seated on supply hub, or file-protect circuit failure.
10110	13	Supply reel did not remain locked during unload, or tape-in-path failure during load, or too much slack in the tape to allow tensioning.
01110	14	Tape travel beyond EOT exceeded 18 feet.
11110	15	Reel seat/file protect sensor failed.
10001	17	Tension arm swing exceeded normal range.
01001	18	Tape speed variation exceeded $\pm 10\%$.
11101	23	Load attempted without tape reel
11011	27	Load attempted with front panel door open.
10111	29	Tape reel upside-down or tape-in-path sensor failed.
01111	30	BOT not detected after 35 feet of tape.
11111	31	Load failure.

Table 5-1. Error Codes

DRIVE DIAGNOSTICS

There are two categories of diagnostic service aids: those that run with a tape loaded and those that run without tape. All service aids are invoked the same way. Several service aids require that the interlock be disabled; see the "Interlock Disable Procedure" in Chapter 6.

Diagnostic Mode Entry

The diagnostic mode is invoked using the switches on the front panel. Each switch has a decimal number significance as shown in Figure 5-2.

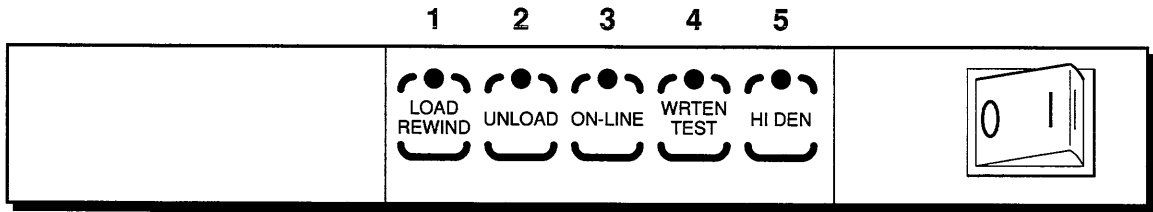

Figure 5-2. Front Panel Switches Decimal Numbered

Entering a five-digit numeric sequence invokes a Service Aid (and the diagnostic mode). The sequence is "45XX5," with the two X's representing the code of the desired Service Aid. The five numbers must be entered within three seconds or diagnostic entry is aborted. For example, to execute Service Aid 12, press switch 4, then 5, then 1, then 2, and then 5.

Service Aids (and the diagnostic mode) are exited by pressing switch 4.

Tape Unloaded Diagnostics

The following sections describe the service aids that are run without tape loaded in the drive.

Service Aid 11 (Servos)

This service aid tests the supply and take-up motors and their servo circuits. Both hubs rotate, alternating clockwise and counterclockwise. Pressing the LOAD switch enables the high-voltage drivers while limiting the maximum current to one ampere; UNLOAD disables the high-voltage rails.

Service Aid 12 (Write Data)

This service aid enables and disables the write circuitry. Pressing the LOAD switch simulates a 100-ips data rate; UNLOAD simulates the 25-ips rate. If the ILWD signal is asserted, a one-character record that includes a preamble and postamble is written.

Service Aid 13 (Write File Mark)

This service aid functions like Service Aid 12 except that the file mark signals are enabled.

Service Aid 14 (Tachometer)

This service aid samples the phase relationship for each quadrature of the tachometer. See Figure 5-3. Initially, all LEDs are lit; then the percentage of phase shift for quadrature 00 is displayed as a binary number. An eight equals a phase shift of approximately 90 degrees. The minimum acceptable phase shift is 30 degrees or a binary three.

Pressing the LOAD switch causes the phase shift of quadrature 01 to display, pressing a second time displays quadrature 11, and a third time displays quadrature 10.

Pressing the LOAD switch a fourth time causes the servo to reverse and display quadrature 00's phase shift in this direction. Subsequent actuations of LOAD display the other quadratures in the same sequence as above.

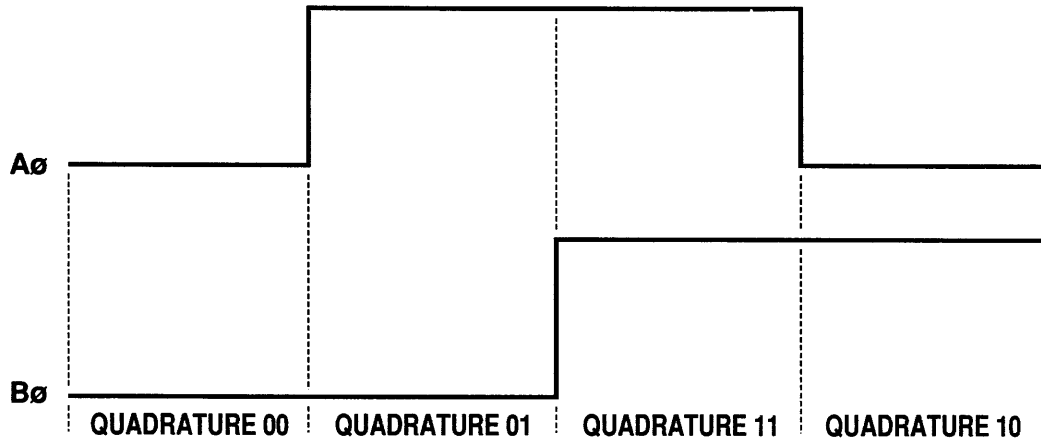

Figure 5-3. Tachometer Phase Quadrature

Service Aid 21 (Circuit Board)

This service aid activates various status signals. IONL and IRWD are toggled; then IFBY, IRDY, IDBY, IFPT, ILDP, and IEOT are toggled; finally IRSTR, FWD, ENRD, and ENFMG are toggled. Then there is a ten-millisecond delay before this toggling sequence is repeated.

The various signals are toggled in binary sequence to provide easily recognizable patterns for troubleshooting. The signals are available at the PIOs and in the read formatter circuitry.

Service Aid 22 (BOT Sensor)

This service aid measures the output voltage of the BOT sensor and displays it at the LEDs as binary numbers. (Accurate readings are more likely if the sensor is shielded from ambient light.) The output voltage varies when a reflective marker is passed in front of the light beam. The binary output of the LEDs can be converted to the decimal value of the sensor's output voltage with Table 5-2.

LOAD	UNLOAD	ONLINE	WRT EN	HI DEN	Voltage
0	0	0	0	0	0.00
0	0	0	0	1	2.56
0	0	0	1	0	1.28
0	0	0	1	1	3.84
0	0	1	0	0	0.64
0	0	1	0	1	3.20
0	0	1	1	0	1.92
0	0	1	1	1	4.48
0	1	0	0	0	0.32
0	1	0	0	1	2.88
0	1	0	1	0	1.60
0	1	0	1	1	4.16
0	1	1	0	0	0.96
0	1	1	0	1	3.52
0	1	1	1	0	2.24
0	1	1	1	1	4.80
1	0	0	0	0	0.16
1	0	0	0	1	2.72
1	0	0	1	0	1.44
1	0	0	1	1	4.00
1	0	1	0	0	0.80
1	0	1	0	1	3.36
1	0	1	1	0	2.08
1	0	1	1	1	4.64
1	1	0	0	0	0.48
1	1	0	0	1	3.04
1	1	0	1	0	1.76
1	1	0	1	1	4.32
1	1	1	0	0	1.12
1	1	1	0	1	3.68
1	1	1	1	0	2.40
1	1	1	1	1	4.96

Table 5-2. Service Aids 22 and 23 Conversion Chart

Service Aid 23 (EOT Sensor)

This service aid measures the output voltage of the EOT sensor and displays it at the LEDs as binary numbers. (Accurate readings are more likely if the sensor is shielded from ambient light.) The output voltage varies when a reflective marker is passed in front of the light beam. The binary output of the LEDs can be converted to the decimal value of the sensor's output voltage with Table 5-2.

Service Aid 24 (Tension Arm)

This service aid measures the tension arm output voltage and displays it as a pattern on the front panel LEDs. Two patterns are required to obtain the voltage. The drive always displays the high-order pattern first and the low-order pattern when the LOAD switch is pressed. Pressing the LOAD switch cycles between the high- and low-order patterns.

Tables 5-3A and 5-3B make up a conversion chart that provides the values of the voltages for all possible LED patterns. Table 5-3A has the values for all possible high-order patterns and Table 5-3B has the values for all possible low-order patterns.

When the voltage obtained from the high-order pattern using Table 5-3A is positive, the voltage obtained from the low-order pattern using Table 5-3B can only be positive. In the same way, when the voltage obtained from the high-order pattern using Table 5-3A is negative, the voltage obtained from the low-order pattern using Table 5-3B must be negative. Therefore, the two voltages are always the same, either both positive or both negative, and are always added, whether they are positive or negative, to obtain the result. The LEDs never display a positive voltage in one pattern and a negative voltage in the other pattern.

As an example of a positive voltage, if only the LOAD LED is on (a one in the tables equals on, a zero equals off) while the HI DEN LED is on, and only the WRT EN LED is on while HI DEN is off, the tension arm output voltage is +0.96.

As an example of a negative voltage, if only the ON-LINE and WRT EN LEDs are on while the HI DEN LED is on, and only the WRT EN LED is on while HI DEN is off, the tension arm output voltage is -2.24.

LOAD	UNLOAD	ON-LINE	WRT EN	HIDEN	Voltage
0	0	0	0	1	+0.00
0	0	0	1	1	-4.48
0	0	1	0	1	+2.56
0	0	1	1	1	-1.92
0	1	0	0	1	+1.28
0	1	0	1	1	-3.20
0	1	1	0	1	+3.84
0	1	1	1	1	-0.64
1	0	0	0	1	+0.64
1	0	0	1	1	-3.84
1	0	1	0	1	+3.20
1	0	1	1	1	-1.28
1	1	0	0	1	+1.92
1	1	0	1	1	-2.56
1	1	1	0	1	+4.48
1	1	1	1	1	-0.00

Table 5-3A. Service Aid 24 High-Order Pattern Conversion Chart

Service Aid 24 can also measure the voltage difference between the output of the tension arm at rest and its output when the arm is against the forward bumper. This measurement is obtained by manually moving the tension arm to the forward bumper then pressing the UNLOAD switch. The patterns obtained are converted to voltages with Tables 5-3A and 5-3B.

Service Aid 31 (Sensors)

This service aid checks the File-Protect/Reel-Seated Sensor and the Tape-In-Path Sensor.

The File-Protect/Reel-Seated Sensor is checked by placing a tape reel without a write-enable ring on the supply hub and running the service aid. As the supply hub rotates, a quick double-pulse of the UNLOAD LED occurs, indicating that the tape is write protected. The double-pulsing can only be observed by grasping and manually rotating the supply hub until the reel-seated reflector moves past the sensor; otherwise, the double-pulse blurs into a single pulse. Installing a write-enable ring in the reel causes the UNLOAD LED to produce both a double-pulse and a single pulse, which indicates that the tape is write-enabled.

LOAD	UNLOAD	ON-LINE	WRT EN	HI DEN	Voltage
0	0	0	0	0	+0.00 or -0.64
0	0	0	1	0	+0.32 or -0.32
0	0	1	0	0	+0.16 or -0.48
0	0	1	1	0	+0.48 or -0.16
0	1	0	0	0	+0.08 or -0.56
0	1	0	1	0	+0.40 or -0.24
0	1	1	0	0	+0.24 or -0.40
0	1	1	1	0	+0.56 or -0.08
1	0	0	0	0	+0.04 or -0.60
1	0	0	1	0	+0.36 or -0.28
1	0	1	0	0	+0.20 or -0.44
1	0	1	1	0	+0.52 or -0.12
1	1	0	0	0	+0.12 or -0.52
1	1	0	1	0	+0.44 or -0.20
1	1	1	0	0	+0.28 or -0.36
1	1	1	1	0	+0.60 or -0.04

Table 5-3B. Service Aid 24 Low-Order Pattern Conversion Chart

The Tape-In-Path Sensor is checked when tape breaks its light beam. Without tape, the LOAD LED is on; with tape, the LOAD LED is off.

Service Aid 32 (Hub Lock)

This service aid rotates the supply hub while enabling the hub lock solenoid and raising the pawls. If the front panel door is not closed, the ON-LINE LED goes on.

Service Aid 33 (Door Lock Disable)

This service aid disables the the door lock. It is reenabled when a tape is unloaded following a load or when the drive is switched off.

Service Aid 34 (Blower Motor)

This service aid provides manual control of the blower motor via the LOAD switch. When the LOAD LED is on, the blower motor is on; when the LOAD LED is off, the motor is off.

Tape Loaded Diagnostics

The following sections describe the service aids that are run with tape loaded in the drive.

Service Aid 21 (Read Threshold Adjustment)

This service aid provides a means to adjust the read threshold circuit using the LOAD and UNLOAD LEDs. The use of this service aid is explained in Chapter 6 under the heading "Read Threshold Adjustment."

Service Aid 22 (Tension Arm Motion)

This service aid cycles the tape forward and in reverse while changing speed between 25 and 100 ips. The LEDs flash to display the relative tension arm motion as a binary number.

Service Aid 23 (Write Data)

This service aid writes data blocks at 25 ips (LOAD switch pressed), 100 ips (UNLOAD pressed), or 50 ips (drive already in high-density mode before the service aid is invoked; LOAD or UNLOAD pressed after service aid starts). Before running this service aid the ILWD line must be grounded to generate a one-character data block with postamble; if it is not, the hard error and the corrected error statuses are reported. If the tape reel is not write-enabled, only data already written to the tape can be read. A read reverse is performed if the HI DEN switch is pressed while LOAD or UNLOAD is being pressed to select the desired speed.

SCSI DIAGNOSTICS

The SCSI interface generates error and exception data that can be accessed by a host with the Request Sense command. This section describes available data, as well as the diagnostic functions available through the Send Diagnostic command.

Sense Keys

The Sense Keys supported by the tape drive are listed in Table 7-30.

Additional Sense

Table 7-31 provides the Additional Sense Codes returned by the drive in response to a Request Sense command.

Status Bytes

Bytes 23 to 26 of the Extended Sense Data, which are returned to an initiator in response to a Request Sense command, provide additional data that can be useful when troubleshooting. Tables 7-27, 7-28, 7-29, 7-32, and 7-33 provide the available data.

Diagnostic Commands

The Send Diagnostic command executes diagnostic functions in the SCSI controller. The Receive Diagnostic Results command returns the results of the diagnostic functions to the initiator. Two diagnostic functions are supported: Diagnostic Inquiry and Test Buffer.

Diagnostic Inquiry

The Diagnostic Inquiry (D0) function reports the SCSI data buffer size (64k) in the data field of the Receive Diagnostic command. The function returns 64 bytes of data; however, only the first two bytes contain valid data (FFFF). The remaining bytes are zero. The "FFFF" denotes that the buffer is 64 kilobytes.

Test Buffer

The Test Buffer (D1) function tests the SCSI data buffer. The logical block offset value is supported. This value is multiplied by the mode-selected block size to obtain the byte offset in the buffer. On a Send Diagnostic command the data is transferred into the buffer at this offset. On the Receive Diagnostic command, the data is then transferred from the buffer to the initiator.

The Test Buffer function can only be issued when the data buffer is empty, unless the Device or the Unit Off-line bit (0 and 1 of the Command Descriptor Block of the Send Diagnostic command) is set to one.

SCSI Power-up Diagnostics

Level 0 diagnostics are power-up routines that test the SCSI controller before allowing any SCSI function to be executed. Toggling the reset switch, switch number 1 of U2C, resets the SCSI controller, causing the Level 0 diagnostics to execute; normally switch 1 is open/off.

Eight LEDs on the back of the main circuit board provide the status of the Level 0 diagnostics the last time they were executed. See Figure 5-4. The LEDs are labelled 7 to 0, with 7 being the most significant bit and 0 the least significant bit. The LEDs output the status code as a hexadecimal byte. Successful completion of the Level 0 diagnostics is indicated by the code 90. Table 5-4 lists the codes and their meaning. The error codes identify the point in the power-up sequence where a failure occurred.

If power-up fails, the clear-power-up flag remains set and the first SCSI function results in an error status.

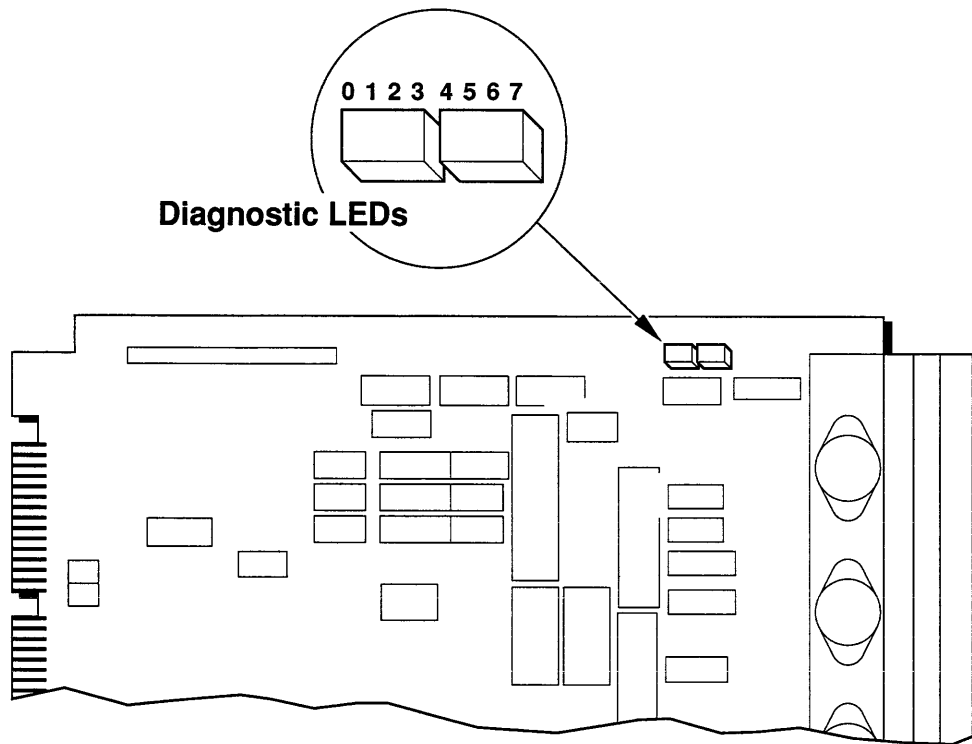

Figure 5-4. Location of Diagnostic LEDs

7 6 5 4	3 2 1 0	Hex Code	Function
1 0 0 1	0 0 0 0	90	No failures
1 0 0 1	0 0 0 1	91	PROM 1 sum check
1 0 0 1	0 0 1 0	92	PROM 2 sum check
1 0 0 1	0 0 1 1	93	PROM 3 sum check
1 0 0 1	0 1 0 0	94	8085, register and memory commands
1 0 0 1	0 1 0 1	95	RAM, set stack pointer
1 0 0 1	0 1 1 1	97	Timer
1 0 0 1	1 0 0 0	98	SCSI chip
1 0 0 1	1 0 0 1	99	8085, jump and initial command
1 0 0 1	1 0 1 1	9B	DMA registers
1 0 0 1	1 1 0 0	9C	DMA data paths
1 0 0 1	1 1 1 1	9F	Data buffer

Table 5-4. Level 0 Diagnostics Error Codes

Chapter 6 Removal, Replacement, and Adjustment Procedures

INTRODUCTION

This section explains how to remove and replace various components and assemblies of the tape drive and how to perform necessary adjustments. These procedures are intended for use by qualified technicians thoroughly familiar with the drive. Each procedure assumes the tape drive is already in the service access position.

TOOLS AND MATERIALS

Table 6-1 lists the special tools and materials necessary to service the tape drive.

Item	Part Number
Hub-height adjustment tool	760105-545
Spring scale, 0-36 oz	
Torque seal	209994-025
Loctite® 242	209990-074
Loctite 601	209990-076
Lubriplate	210444
Master skew tape	799019-401
Reference level tape	203336-006
Cleaning Kit	960855-001
Interlock Disable Tool	971742-001

Table 6-1. Special Tools and Materials List

PART NUMBERS

Table 6-2 lists the part numbers of commonly replaced parts, most of which are discussed in the following procedures. Part numbers for items not listed are available from Cipher Customer Service.

Part Description	Part Number
Air Filter	960027-001
Blower	961604-002
Cable, Read	963772-001
Cable, Write	960413-001
Chassis	966483-101
Door	963744-001
Door Lock	964522-002
EOT/BOT Sensors	160101-009
File-Protect Sensor	160101-005
Front Panel	964035-002
Front Panel Control Switches	961414-005
Hub Lock Solenoid	760101-840
Input Air Duct	760101-795
Interlock Switch	971494-001
Left Output Air Duct	760106-554
Main Circuit Board, Single-Ended	966129-001
Main Circuit Board, Differential	966197-001
Manual Release Switch	960930-001
Mounting Slide (one)	960274-002
Mounting Slides Kit	960635-001
Fuse, 3 amp, slow-blow	211151-330
Fuse, 1.5 amp, slow-blow	211151-323
Motor Filter	964962-001
Motor Insulator	760101-756
Output Ducts Adapter	760101-609
Power Cord, 250V, 7.5 feet	970035-001
Power Cord, 250V, 15 feet	970035-003

Table 6-2. Part Numbers of Replaceable Items (1 of 2)

Part Description	Part Number
Power Cord, 125V, 7.5 feet	970035-005
Power Cord, 125V, 15 feet	970035-002
Power Supply Housing	960292-004
Power Supply Circuit Board	960415-001
Power Switch	960180-001
Read/Write Head	961139-001
Right Output Air Duct	760106-555
Roller Guide 1	160104-401
Roller Guide 2	760104-500
Roller Guide 3, 4, 5	160104-400
Safety Pin	760105-519
Supply Hub	160101-406
Supply Hub Bell Crank	961250-001
Supply Motor	160101-497
Support Arm	963442-001
Tachometer	965366-001
Take-Up Hub	760106-567
Take-Up Motor	961510-201
Tape-In-Path Receiver	160103-433
Tape-In-Path Transmitter	160101-010
Tension Arm	160103-499
Tension Arm Rotor (and Hub)	160101-444
Tension Arm Stator	160101-471
Top Cover	965937-001
Transformer	960199-002
Voltage-Select Circuit Board	760102-102

Table 6-2. Part Numbers of Replaceable Items (2 of 2)

REMOVAL AND REPLACEMENT PROCEDURES

Blower

Refer to Figure 6-1 when removing and replacing the blower.

Removal

1. Perform steps one through ten of the Power Supply Circuit Board Removal procedure, then go to the next step of this procedure.
2. Remove the three nuts (1) securing the blower (2) to the power supply housing, then remove the blower.

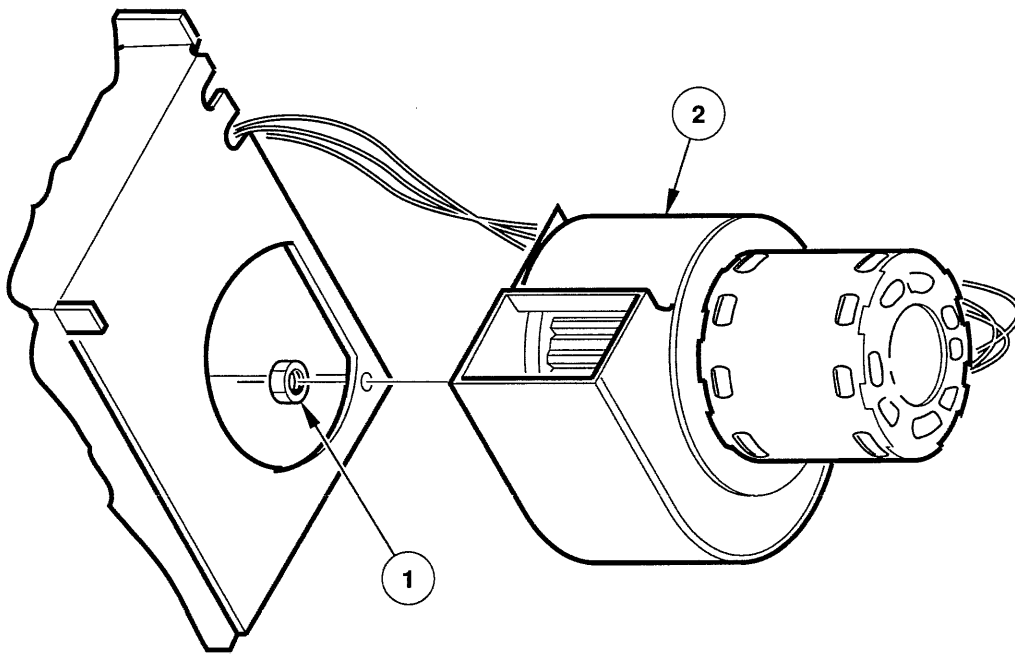

Figure 6-1. Blower

Replacement

1. Follow the Removal procedure in reverse order.

Control Switches

Refer to Figure 6-2 when removing and replacing the control switches.

Removal

1. Disconnect the electrical connector (1).
2. Push the switch assembly (2) out of the front panel. (It is held to the front panel with adhesive.)

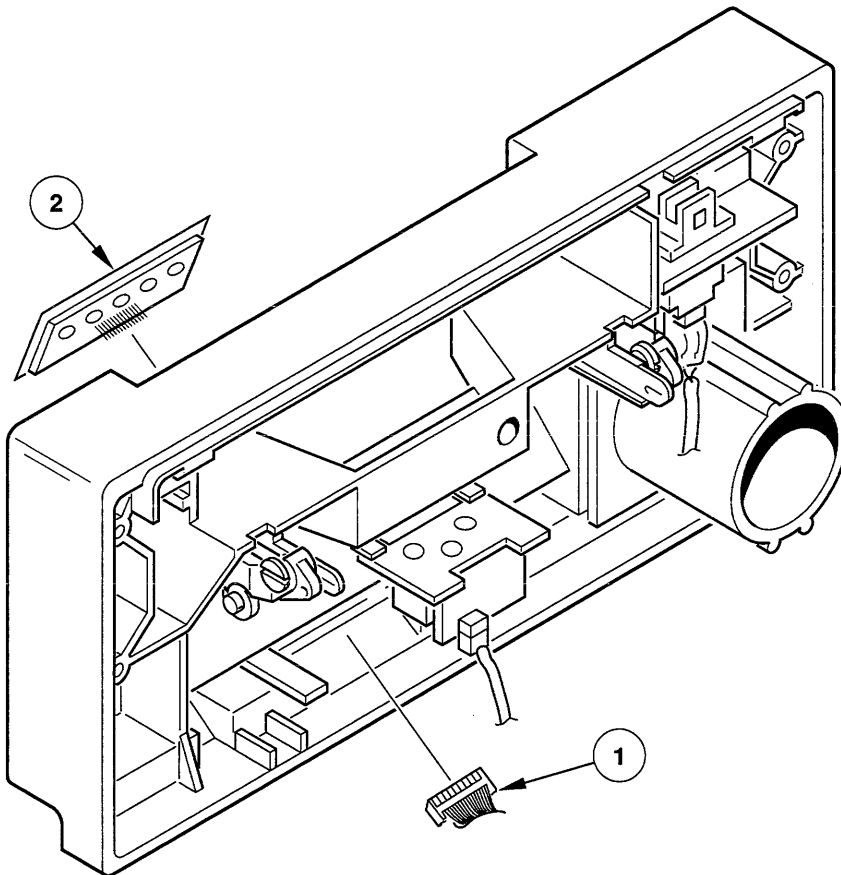

Figure 6-2. Control Switches

Replacement

1. Follow the Removal procedure in reverse order. New control switches must have the adhesive backing removed to install them.

Door

Refer to Figure 6-3 when removing and replacing the door.

Removal

1. Remove the front panel.
2. With the door opened fully, remove each spring (1).
3. Push the door inward to separate the arms (2) from the pivots (3).
4. Remove the door through the opening in the front panel.

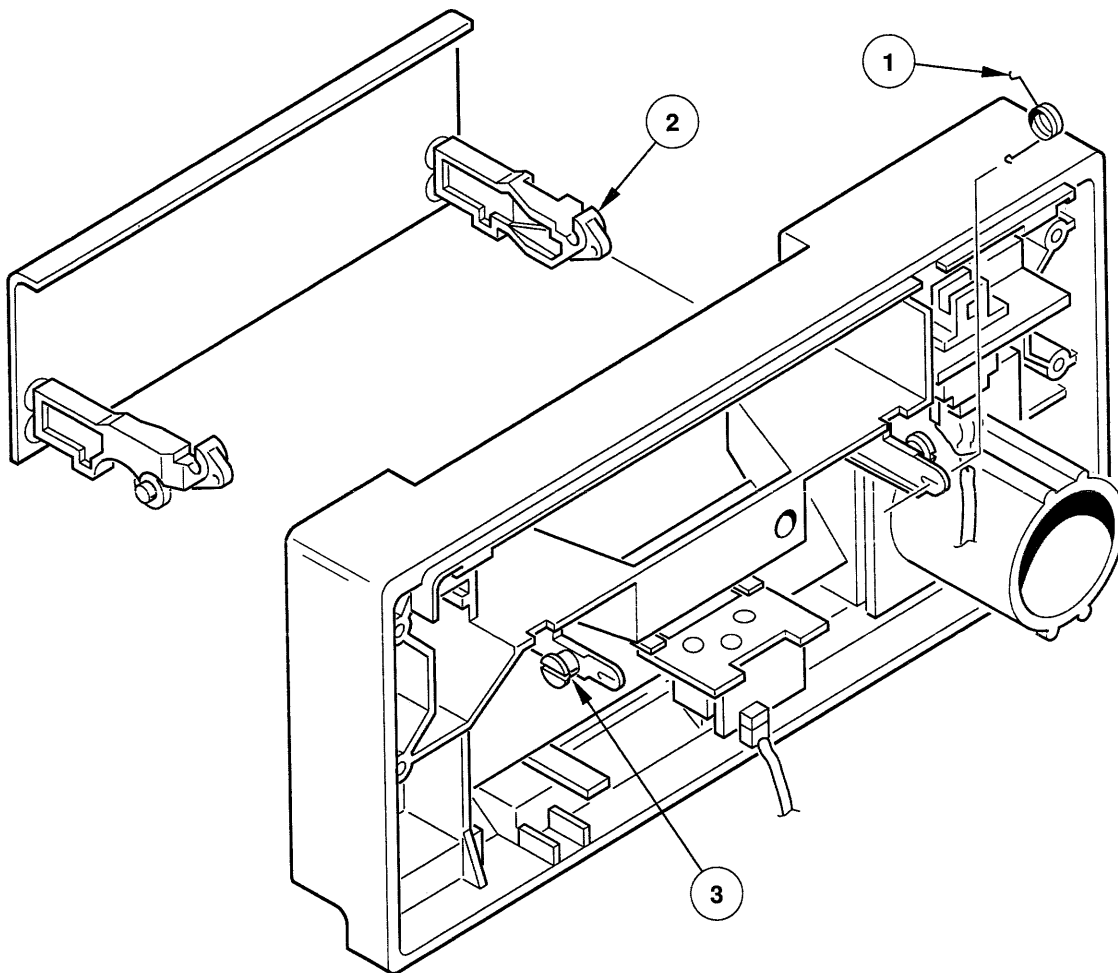

Figure 6-3. Door

Replacement

1. Follow the Removal procedure in reverse order. Put a small amount of Lubriplate on each pivot (3) before snapping the door arms (2) onto the pivots and on the ends of the springs (1).

Door Lock

Refer to Figure 6-4 when removing and replacing the door lock.

Removal

1. Disconnect the cables (1) from the door lock circuit board (2).
2. Remove the two clips (3) securing the door lock (4) to the front panel, then remove the door lock.

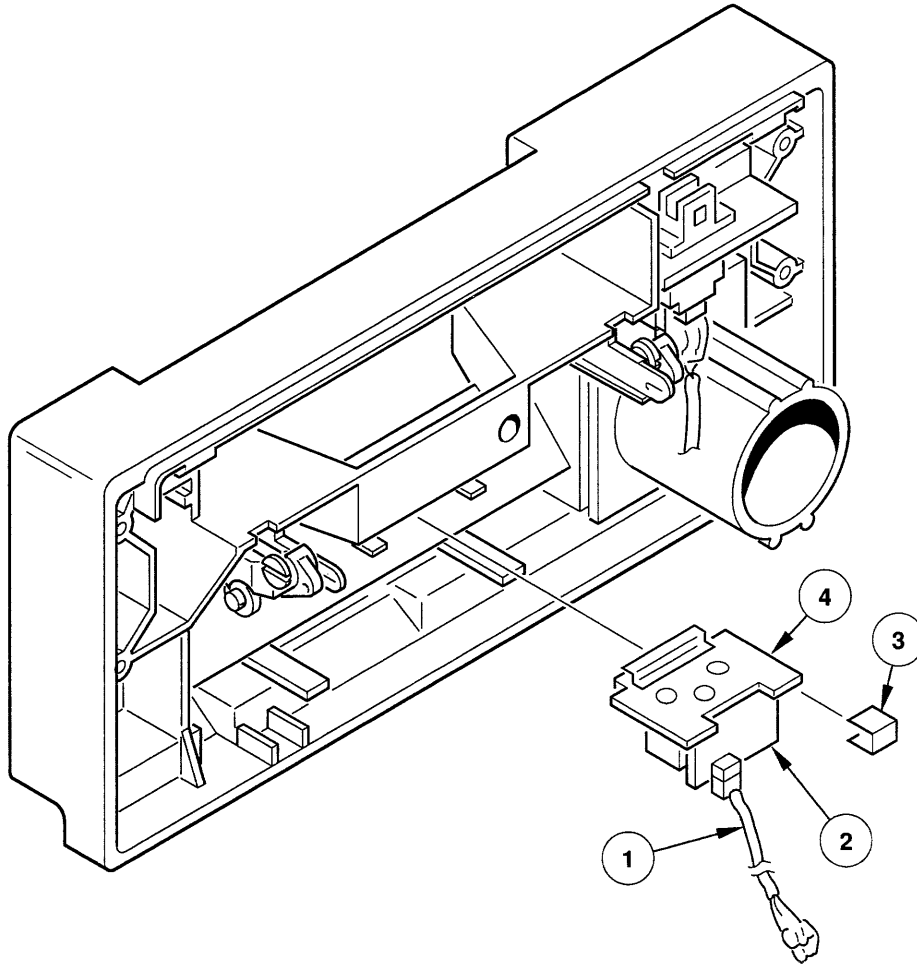

Figure 6-4. Door Lock

Replacement

1. Follow the Removal procedure in reverse order. The tab at the front of the door lock mounting plate slides into a groove in the front panel. The tab on the clips (3) goes downward.
2. Use Service Aid 32 to check that the door lock functions properly.

EOT/BOT Sensors

Refer to Figure 6-5 when removing and replacing the EOT/BOT sensors.

Removal

1. Disconnect the cable (1) from the EOT/BOT sensors (2).
2. Remove the two screws (3) and washers securing the sensors to the deck plate, then remove the sensors.

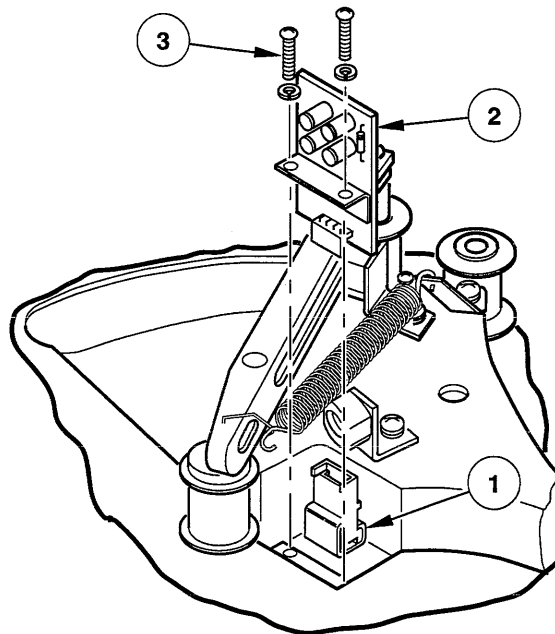

Figure 6-5. EOT/BOT Sensors

Replacement

1. Follow the Removal procedure in reverse order.
2. Use Service Aids 22 and 23 to check that both sensors function properly.

File-Protect Sensor

Refer to Figure 6-6 when removing and replacing the file-protect sensor.

Removal

1. Disconnect the cable (1) from the file-protect sensor (2).
2. Remove the two screws (3) and washers securing the sensor to the deck plate.

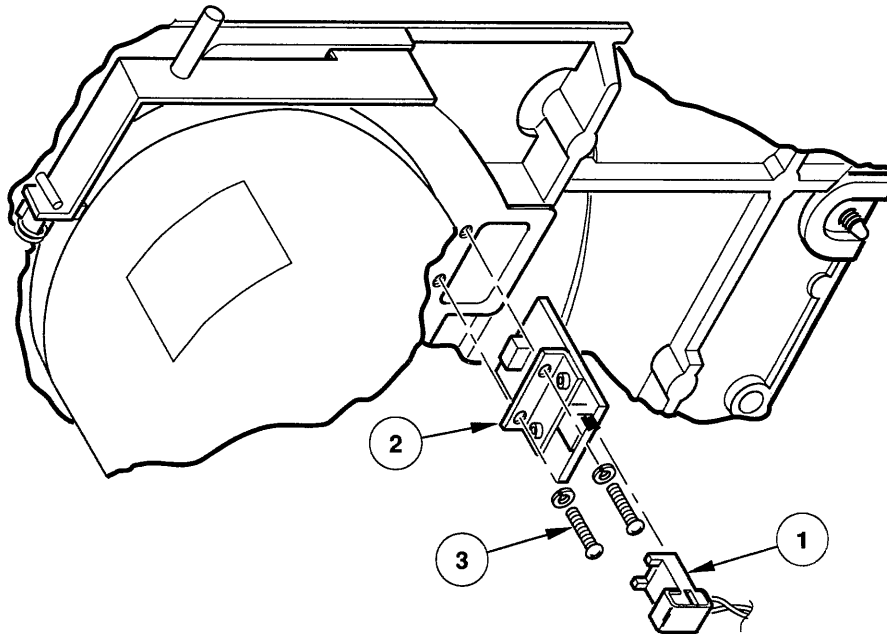

Figure 6-6. File-Protect Sensor

Replacement

1. Follow the Removal procedure in reverse order.
2. Use Service Aid 31 to check that the sensor functions properly.

Front Panel

Refer to Figure 6-7 when removing and replacing the front panel.

Removal

1. Open the front door.
2. Disconnect the electrical connectors (1, 2, and 3).
3. Remove the four screws (4) and washers securing the front panel (5) to the deck plate.
4. Remove the front panel.

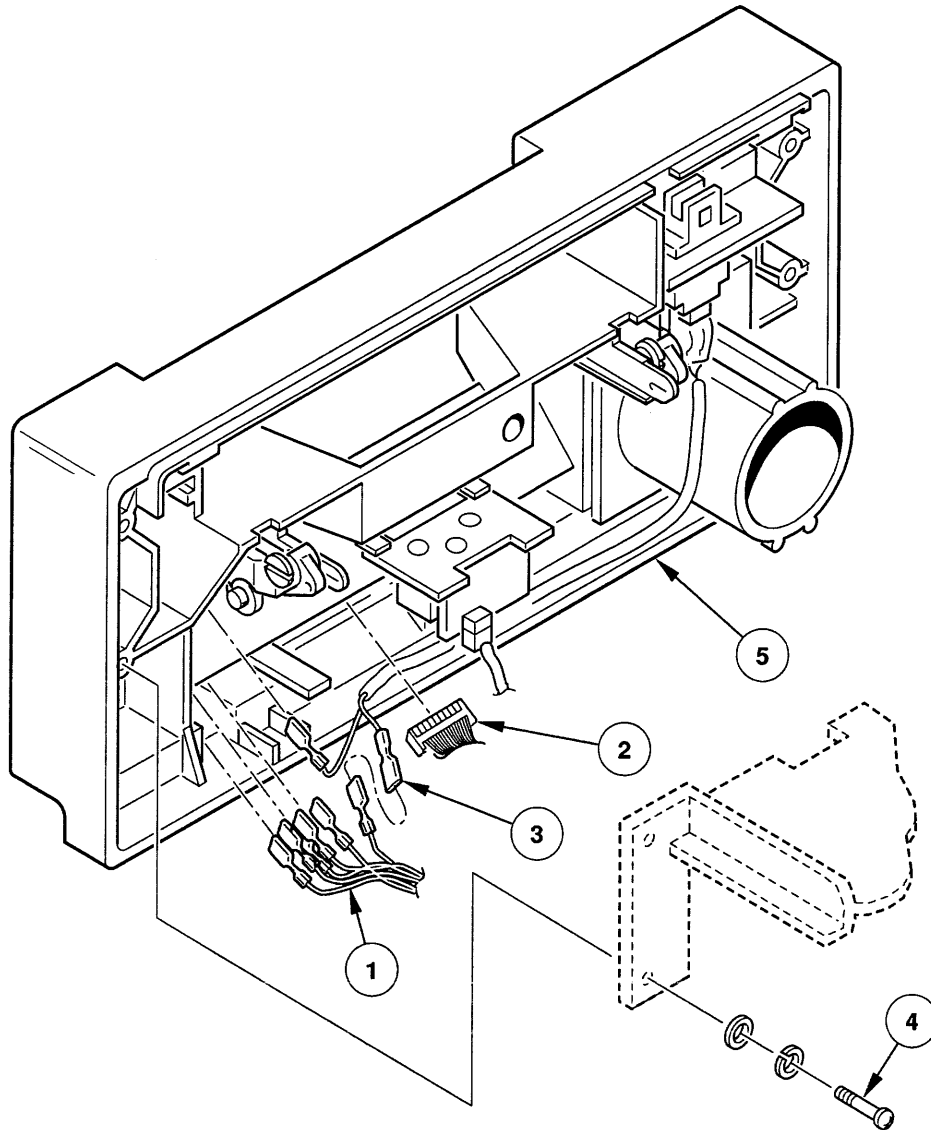

Figure 6-7. Front Panel

Replacement

1. Follow the Removal procedure in reverse order. Ensure that both air ducts fit correctly to the front panel.
2. Use Service Aid 32 to check that the door lock functions properly.

Fuse

Refer to Figure 6-8 when removing and replacing the fuse.

Removal

1. Remove the fuse cap (1).
2. Remove the fuse from the fuse cap.

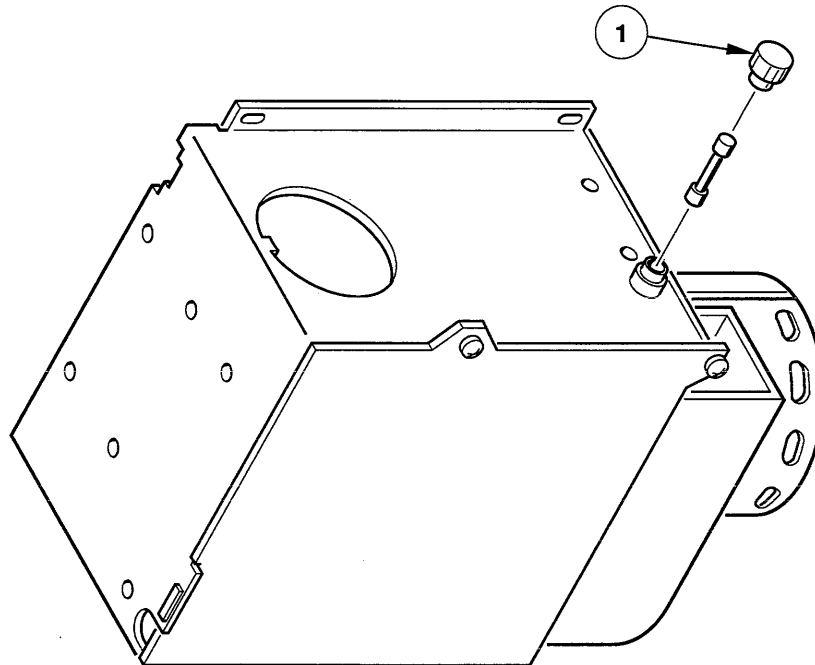

Figure 6-8. Fuse

Replacement

1. Follow the Removal procedure in reverse order. Be sure to use the correct fuse: for 100 to 120 Vac operation, use a 3 ampere, 250 volt, slow-blow fuse; for 208 to 240 Vac operation, use a 1.5 ampere, 250 volt, slow-blow fuse.

Hub Lock Solenoid

Refer to Figure 6-9 when removing and replacing the hub lock solenoid.

Removal

1. Disconnect the cables (1) from the hub lock solenoid (2).
2. Remove the two screws (3) and washers securing the solenoid to the deck plate, then remove the solenoid.

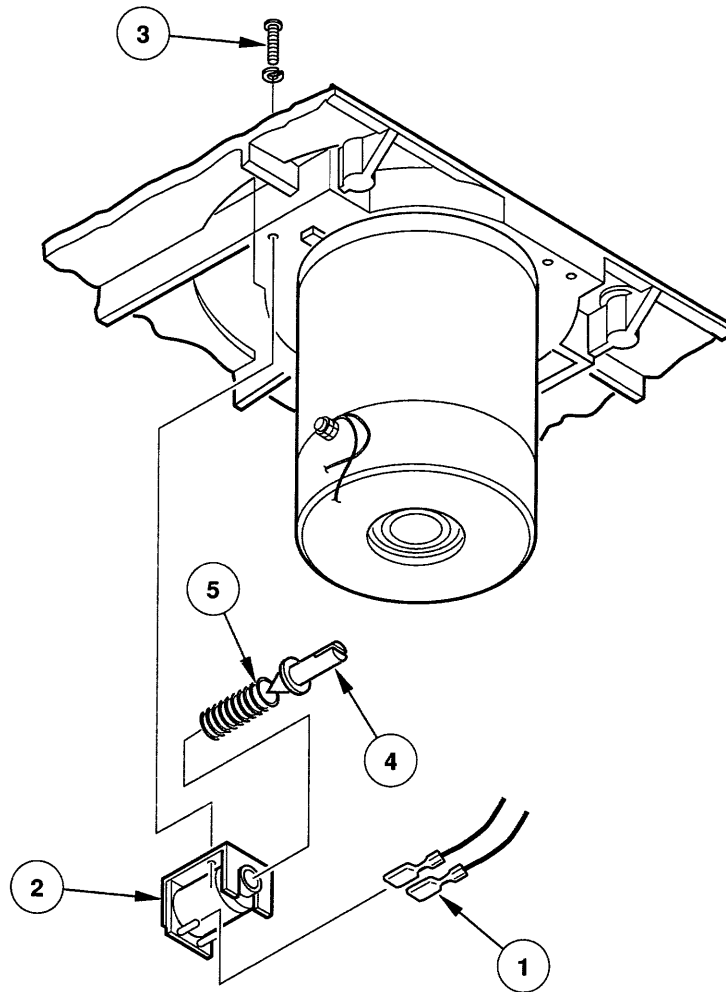

Figure 6-9. Hub Lock Solenoid

Replacement

1. Follow the Removal procedure in reverse order. Be sure that the bell crank plunger (4) is inserted through the spring (5) and into the solenoid (2) and that the bell crank is connected to the hub lock.
2. Use Service Aid 32 to check that the hub lock functions properly.

Input Air Duct

Refer to Figure 6-10 when removing and replacing the input air duct.

Removal

1. Remove the front panel.
2. Remove the input air duct (1) by squeezing the left side of the duct where it enters the power supply housing to disengage the duct from the tooth (2).

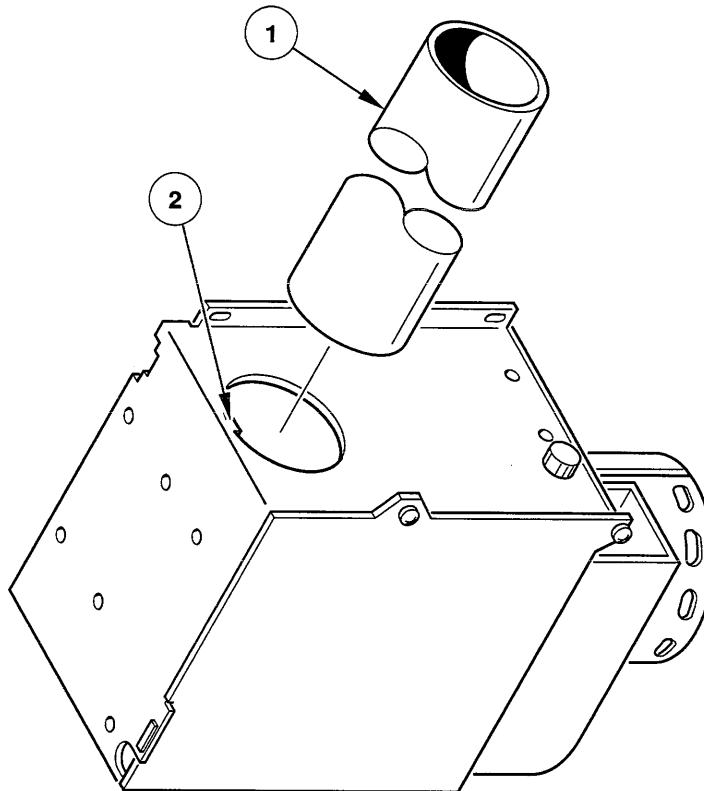

Figure 6-10. Input Air Duct

Replacement

1. Follow the Removal procedure in reverse order. Ensure that the tooth in the power supply housing fits in the hole of the duct.

Interlock Switch

Refer to Figure 6-11 when removing and replacing the interlock switch.

Removal

1. Disconnect the two wires (1) from the interlock switch (2).
2. Press inward on the sides of the switch and move it upward to remove it.

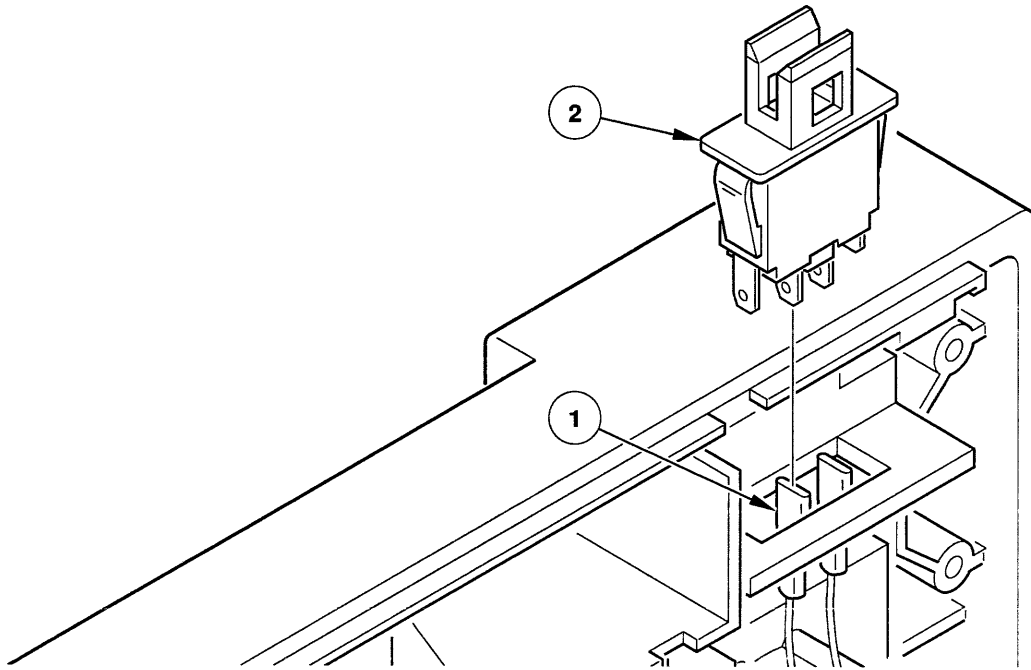

Figure 6-11. Interlock Switch

Replacement

1. Follow the Removal procedure in reverse order.
2. Power-up the drive and check that the interlock functions properly by lifting the top cover—the drive should shut down.

Left Output Air Duct

Refer to Figure 6-12 when removing and replacing the left output air duct.

Removal

1. Disconnect connectors J4 (1) and J5 (2).
2. Pull the cables through the cable holder (3).
3. Remove the screw (4) and washers attaching the air duct (5) to the deck plate.
4. Disconnect the air duct from the adapter (6).

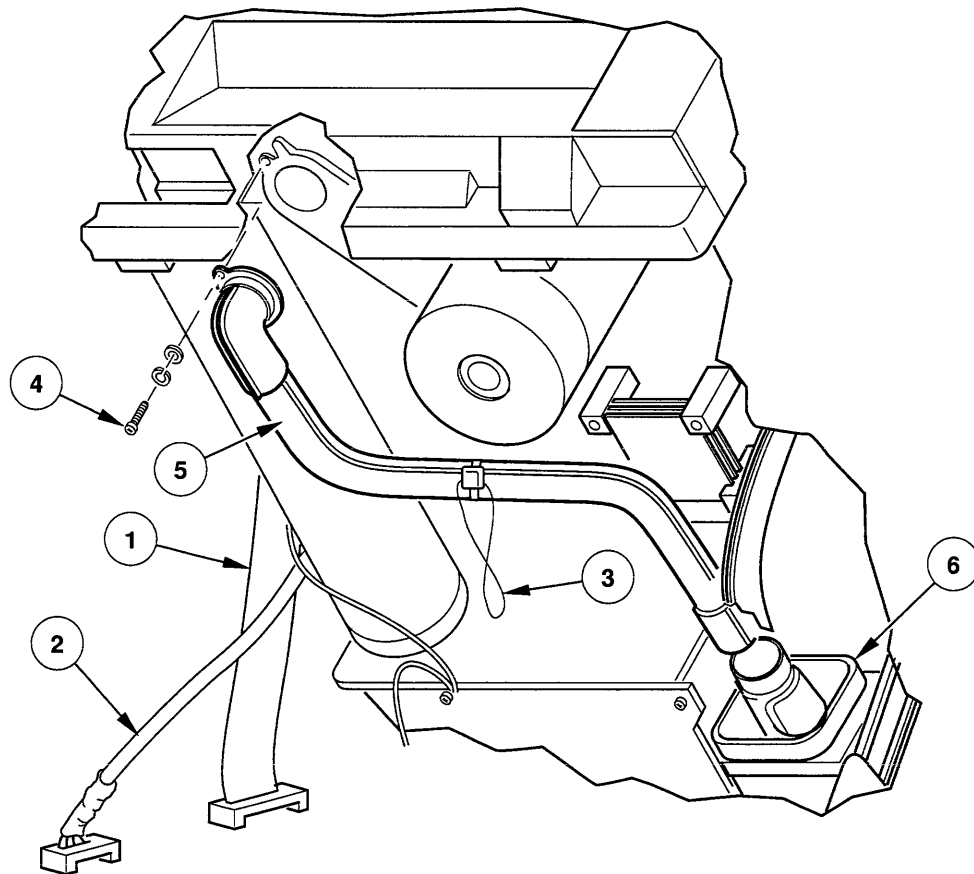

Figure 6-12. Left Output Air Duct

Replacement

1. Follow the Removal procedure in reverse order.

Main Circuit Board

Refer to Figure 6-13 when removing and replacing the main circuit board.

Removal

1. Disconnect the SCSI connector (1).
2. Disconnect connectors J1 (2), J2 (3), J3 (4), J4 (5), and J5 (6).
3. Remove the screw (7) and washers securing the main circuit board (8) to the chassis, then remove the board.

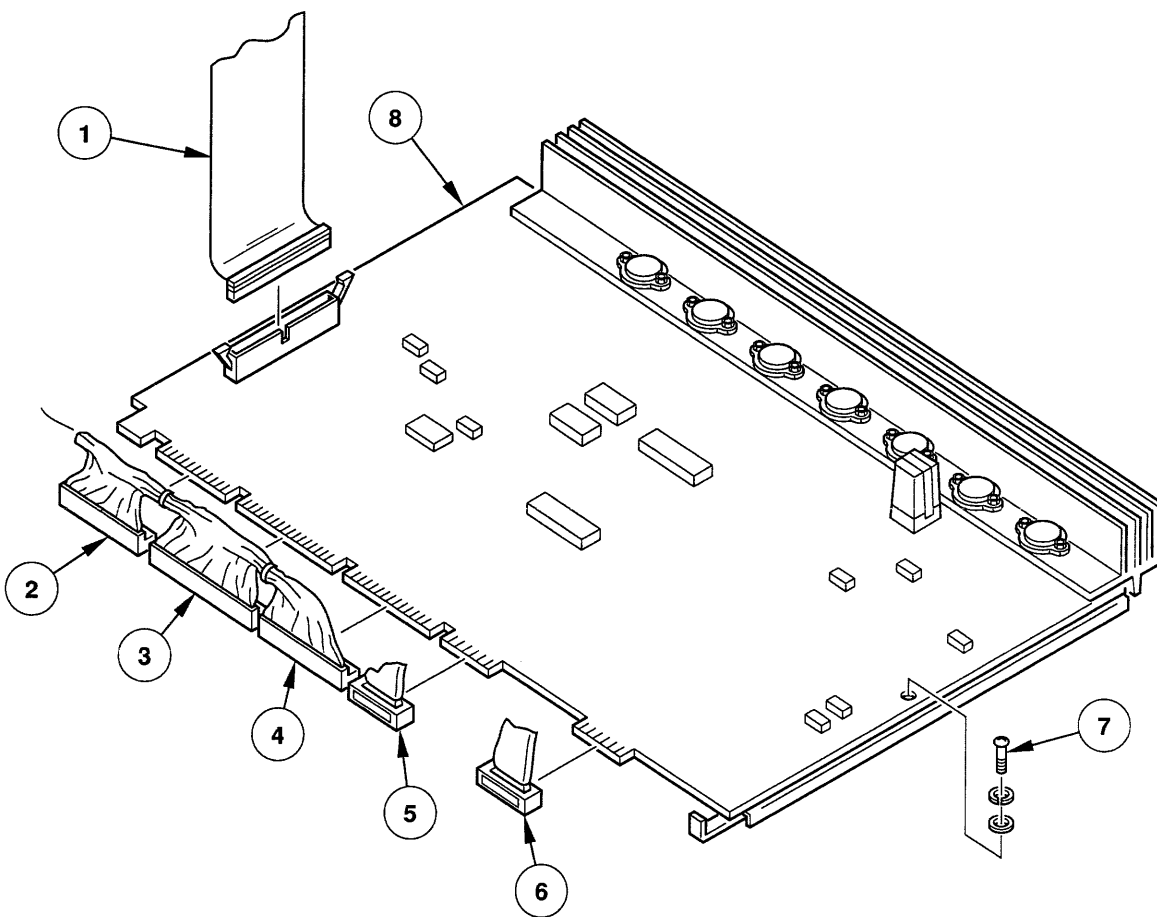

Figure 6-13. Main Circuit Board

Replacement

1. Follow the Removal procedure in reverse order.
2. Perform the Read Threshold Adjustment.

Manual Release Switch

Refer to Figure 6-14 when removing and replacing the manual release switch.

Removal

1. Remove the two screws (1) and washers securing the manual release switch (2) to the deck plate, then remove the release switch.

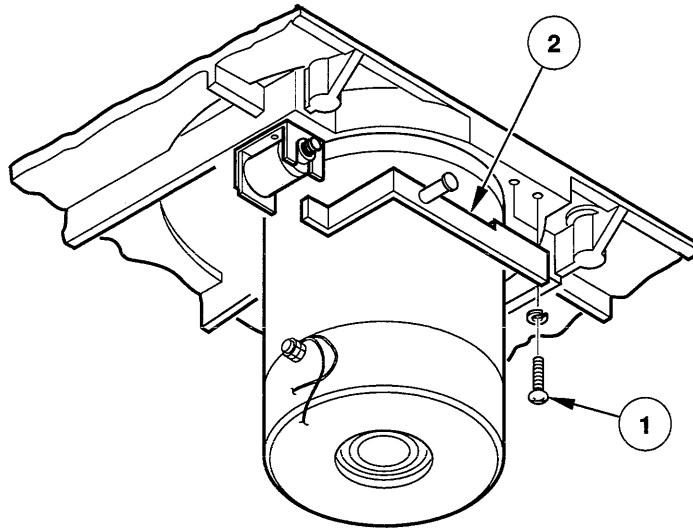

Figure 6-14. Manual Release Switch

Replacement

1. Follow the Removal procedure in reverse order.

Power Supply Circuit Board

Refer to Figure 6-15 when removing and replacing the power supply circuit board.

Removal

1. Remove the main circuit board, the front panel, the input air duct, the right output air duct, and the left output air duct.
2. Remove the two screws (1) and washers securing the power supply housing cover (2).
3. Remove the cables from the cable holder (3).
4. Disconnect the take-up motor wires (4) from the motor filter (5).
5. Disconnect connector J7 (6) from the power supply circuit board.
6. Disconnect the line filter output wires (7) from the power supply circuit board.
7. Disconnect the blower motor wires (8) from the power supply circuit board.
8. Remove the screw (9) and washers securing the blower bracket to the deck plate.
9. Remove the two screws (10) and washers securing the power supply housing to its brackets.
10. Remove the two screws (11) and washers securing the front of the power supply housing to the deck plate, then remove the housing.
11. Disconnect connectors J5 (12), J6 (13), and J8 (14) from the power supply circuit board.
12. Remove the four screws (15) and washers securing the power supply circuit board, then remove the power supply circuit board. Feed the harness through the hole in the circuit board while removing the circuit board.

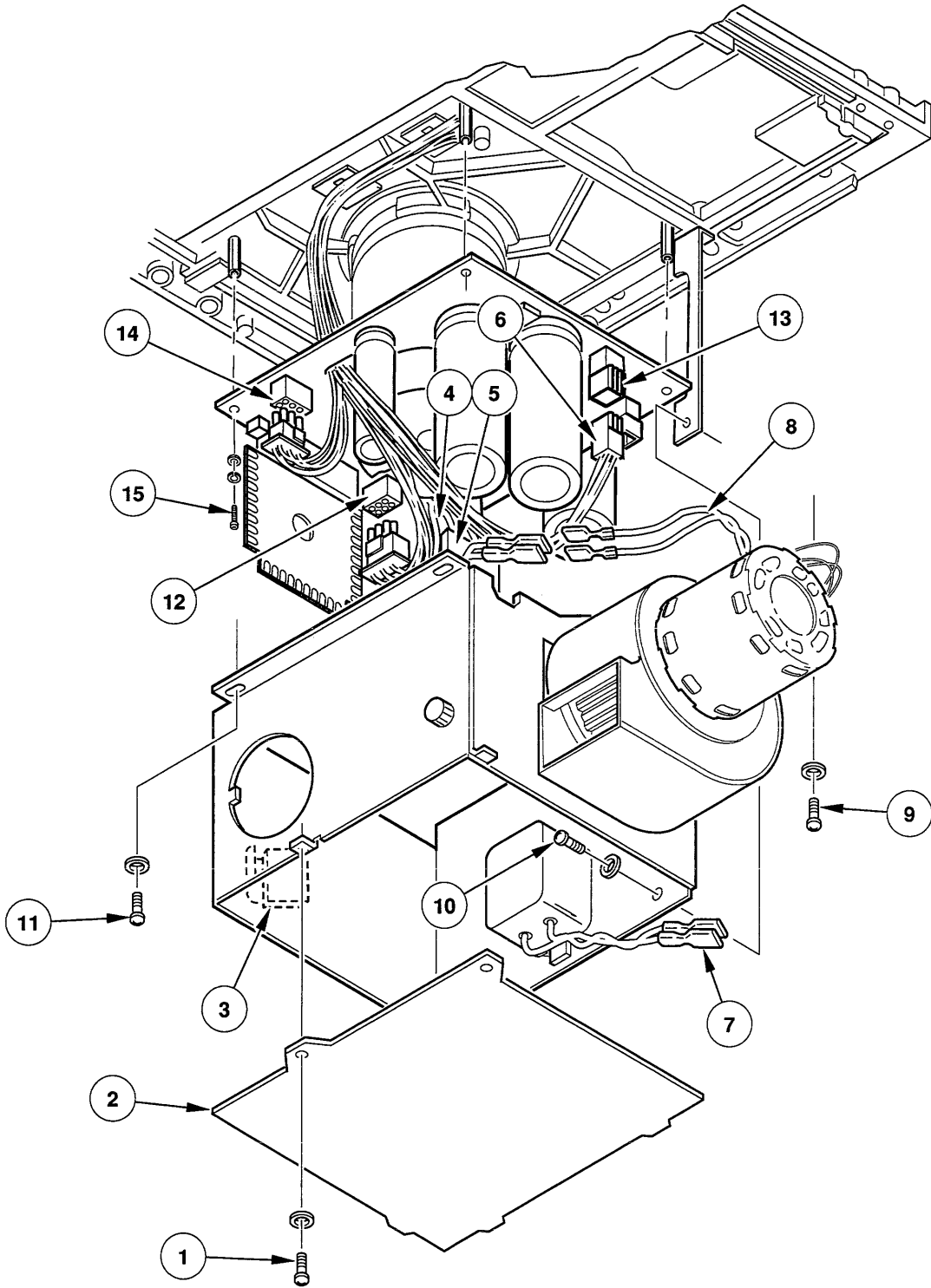

Figure 6-15. Power Supply Circuit Board

Replacement

1. Follow the Removal procedure in reverse order.

Power Switch

Refer to Figure 6-16 when removing and replacing the power switch.

Removal

1. Disconnect the wires (1) connected to the power switch (2).
2. Compress the side tabs securing the power switch in the front panel, then push the switch from the back out the front of the panel.

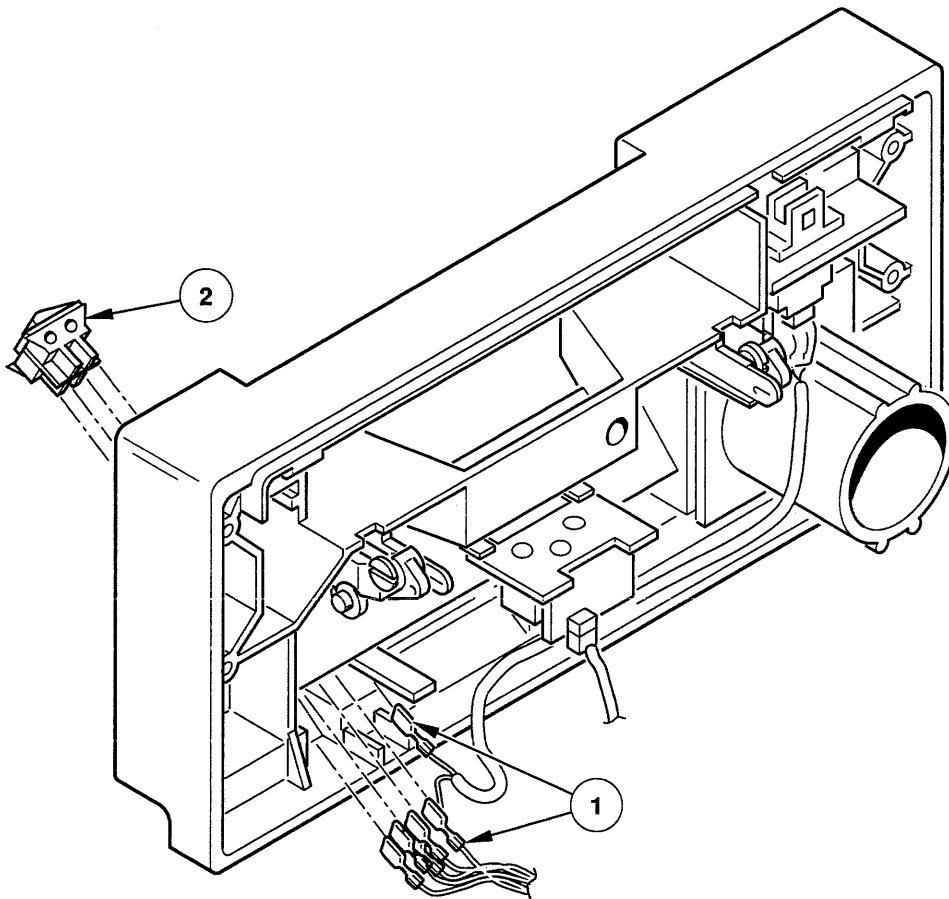

Figure 6-16. Power Switch

Replacement

1. Follow the Removal procedure in reverse order. Insert the power switch from the front of the front panel.

Read/Write Head

Refer to Figure 6-17 when removing and replacing the read/write head.

Removal

1. Perform steps one and two of the Left Output Air Duct Removal procedure, then go to the next step of this procedure.
2. Remove the adjustment screw (1) and washers.
3. Remove the four screws (2) and washers that secure the read/write head (3) to the deck plate. Hold the head while removing the last screw.
4. Remove the head.
5. Remove the cables (4, 5, and 6) from the read/write head.

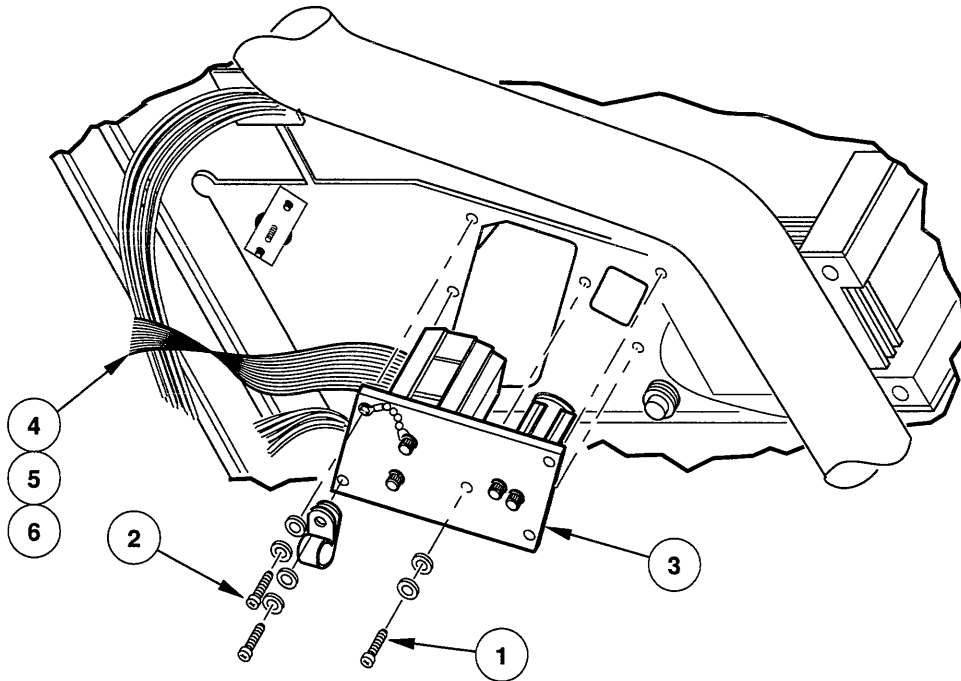

Figure 6-17. Read/Write Head

Replacement

1. Follow the Removal procedure in reverse order. Leave the cover on the head until the installation is completed. When connecting the cables (6) to the erase head, the black cable connects above the red cable.
2. Perform the Tape Alignment Adjustment.
3. Perform the Skew Adjustment
4. Perform the Read Threshold Adjustment.

Right Output Air Duct

Refer to Figure 6-18 when removing and replacing the right output air duct.

Removal

1. Remove the front panel.
2. Remove the tie-wraps (1 and 2) securing the power switch cable (3) and the right output air duct (4).
3. Disconnect the air duct from the adapter (5).

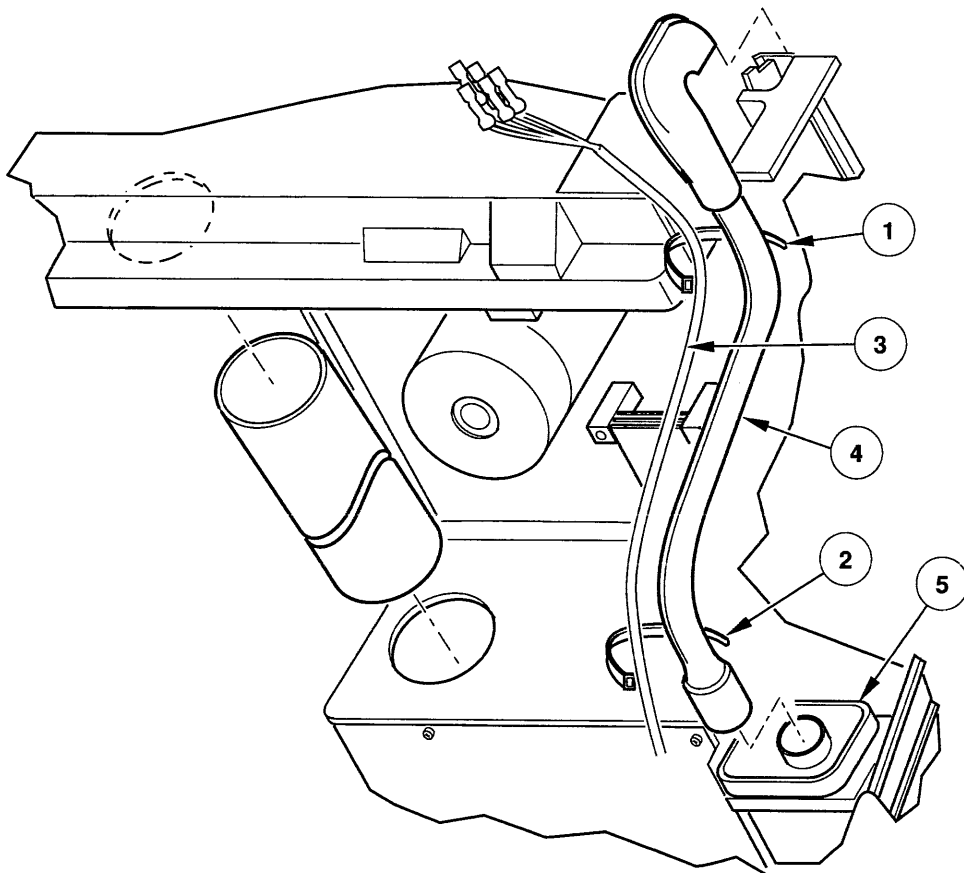

Figure 6-18. Right Output Air Duct

Replacement

1. Follow the Removal procedure in reverse order.

Roller Guide 1

Refer to Figure 6-19 when removing and replacing roller guide 1.

Removal

1. Remove the screw (1) and washers securing the roller guide (2), then remove the roller guide.
2. If there are any shims (3) between the roller guide and the mounting plate (4), save them.

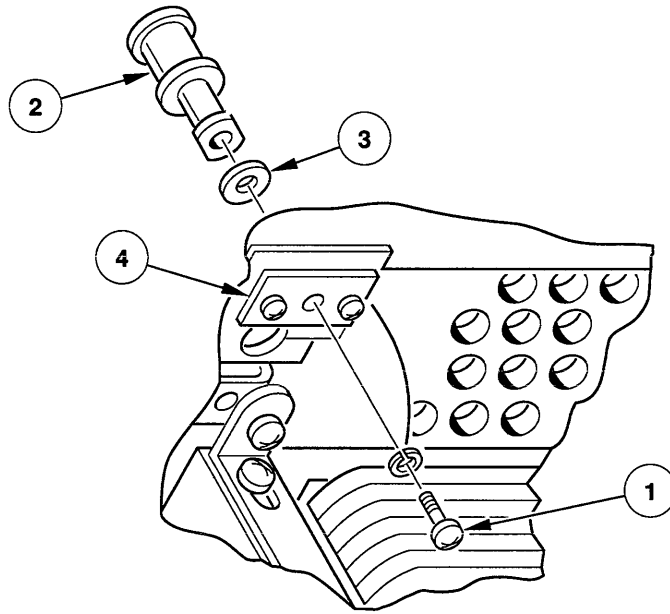

Figure 6-19. Roller Guide 1

Replacement

1. Follow the Removal procedure in reverse order. If you saved any shims (3) when you removed the roller guide, place them between the roller guide (2) and the mounting plate (4).
2. Perform the Tape Alignment Adjustment.

Roller Guide 2

Refer to Figure 6-20 when removing and replacing roller guide 2.

Removal

1. Remove the screw (1) and washers securing the roller guide (2), then remove the roller guide.
2. If there are any shims (3), save them.

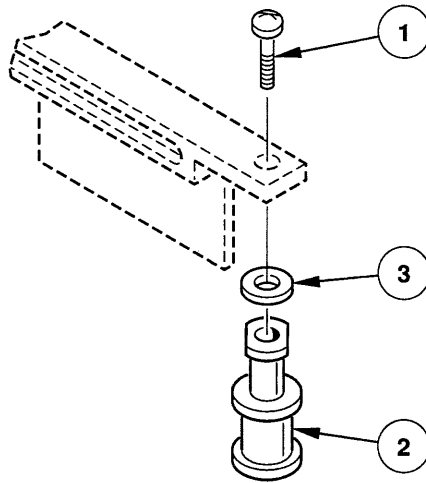

Figure 6-20. Roller Guide 2

Replacement

1. Follow the Removal procedure in reverse order. If you saved any shims (3) when you removed the roller guide, replace them.
2. Perform the Tape Alignment Adjustment.

Roller Guides 3, 4, 5

Refer to Figure 6-21 when removing and replacing roller guides 3, 4, and 5.

Removal

1. Remove the screw (1) and washers securing the roller guide (2), then remove the roller guide.
2. If there are any shims (3) between the spring (4) and the mounting plate (5), save them.

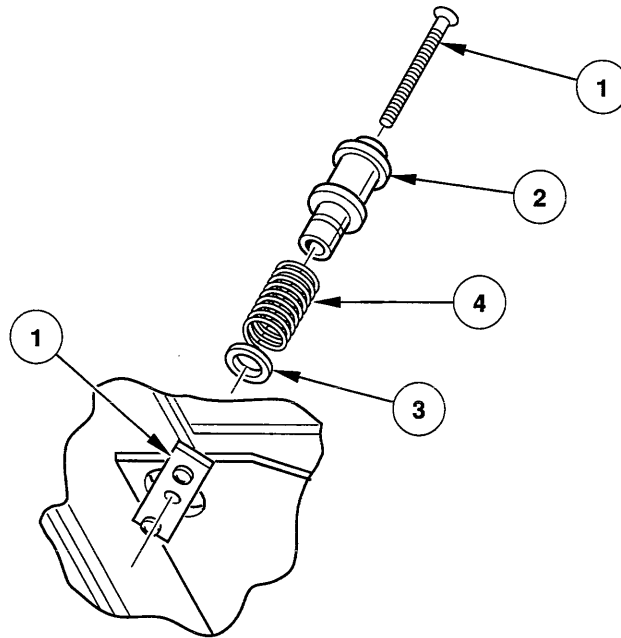

Figure 6-21. Roller Guides 3, 4, 5

Replacement

1. Follow the Removal procedure in reverse order. If you saved any shims (3) when you removed the roller guide, place them between the spring (4) and the mounting plate (5).
2. Perform the Tape Alignment Adjustment.

Supply Hub

Refer to Figure 6-22 when removing and replacing the supply hub.

Removal

1. Rotate the supply hub (1) until the two screws (2) that secure the supply hub to the motor shaft are toward the front door.
2. Loosen the two screws (2), then remove the supply hub.

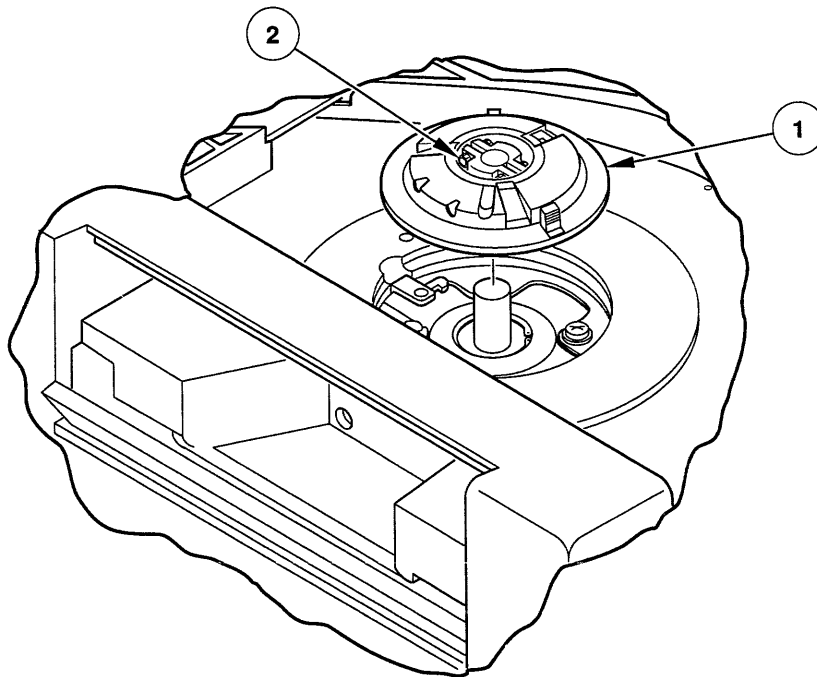

Figure 6-22. Supply Hub

Replacement

1. Install the supply hub (1) on the motor shaft. Do not tighten the two screws.
2. Perform the Supply Hub Adjustment.

Supply Hub Bell Crank

Refer to Figure 6-23 when removing and replacing the supply hub bell crank.

Removal

1. Remove the supply hub and the hub lock solenoid.
2. Remove the clip (1) securing the supply hub bell crank (2) to the supply motor, then remove the bell crank.

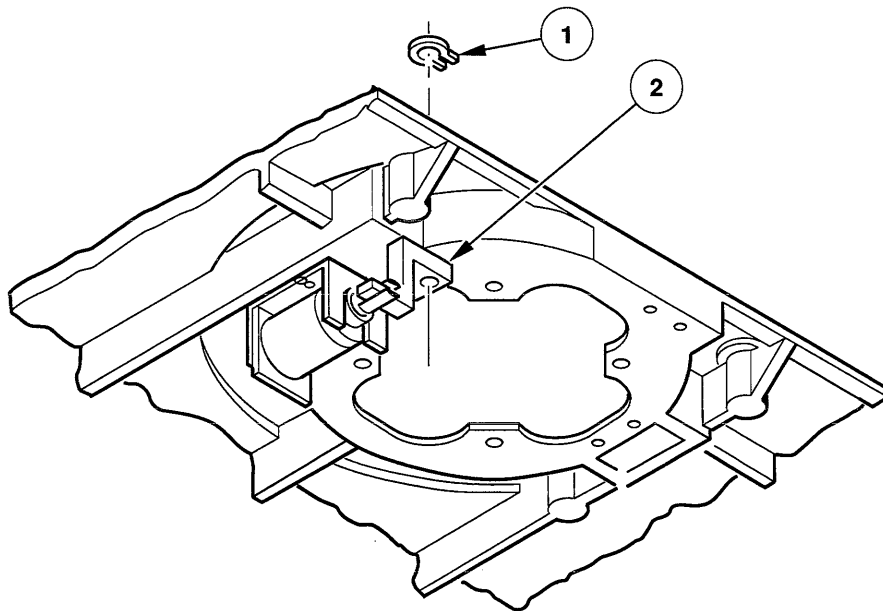

Figure 6-23. Supply Hub Bell Crank

Replacement

1. Follow the Removal procedure in reverse order. Use Service Aid 32 to check the operation of the hub lock after the supply hub is installed.

Supply Motor

Refer to Figure 6-24 when removing and replacing the supply motor.

Removal

1. Remove the supply hub.
2. Remove the clip (1) securing the supply hub bell crank (2) to the supply motor (3).
3. Disconnect the two wires (4) from the motor filter (5).
4. Loosen the four screws (6) securing the supply motor to the deck plate.
5. Hold the motor (3) while removing the four screws (6) and washers.
6. When removing the motor from the deck plate, slide the supply hub bell crank (2) off the stud (7) on the motor.
7. Remove the motor insulator (8) from the motor.

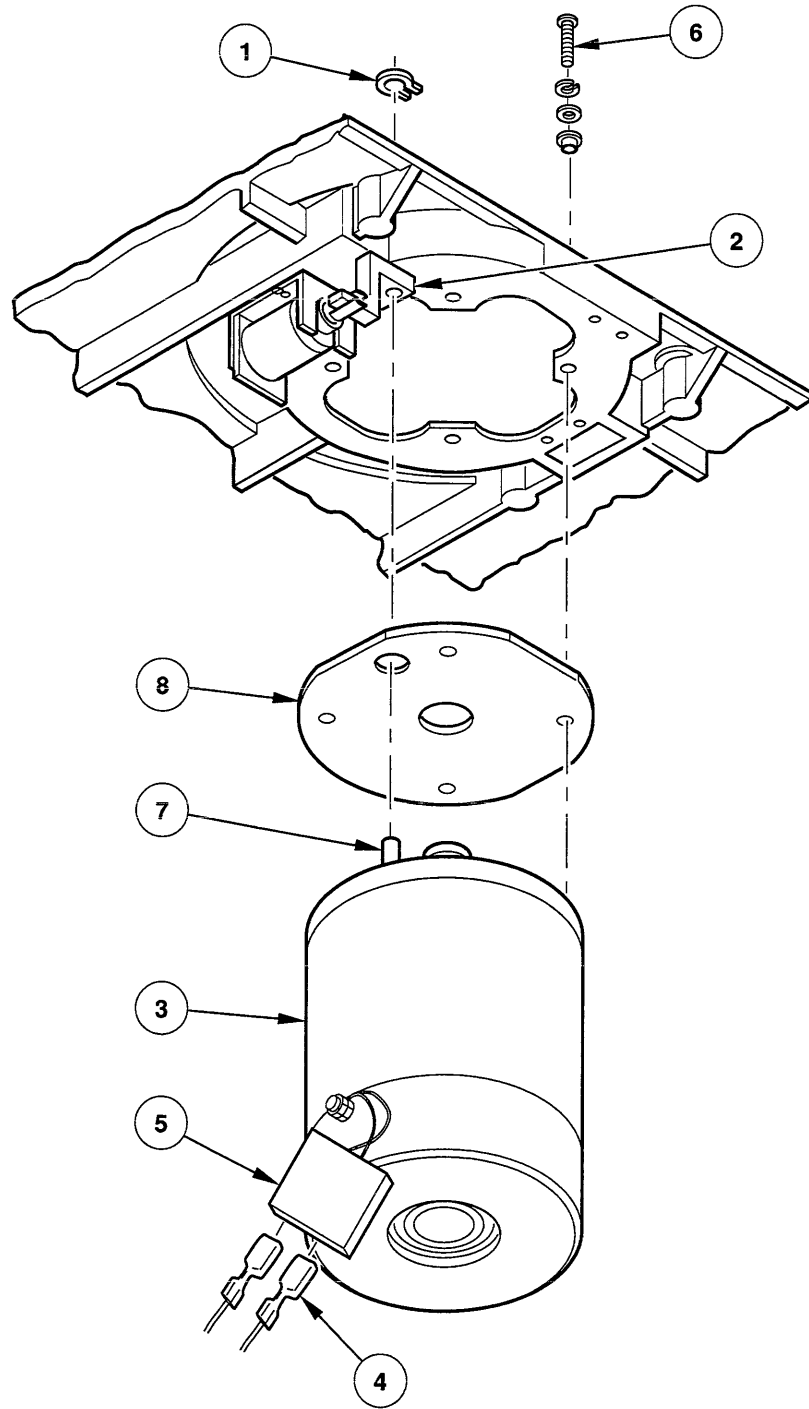

Figure 6-24. Supply Motor

Replacement

1. Follow the Removal procedure in reverse order.

Tachometer

Refer to Figure 6-25 when removing and replacing the tachometer.

Removal

1. Disconnect the tachometer cable (1).
2. Remove the snap ring (2), wavewasher (3), and shims (4).
3. Remove the tachometer (5) from the deck plate.
4. Check whether the upper bearing (6) and lower bearing (7) are damaged. Remove if necessary.

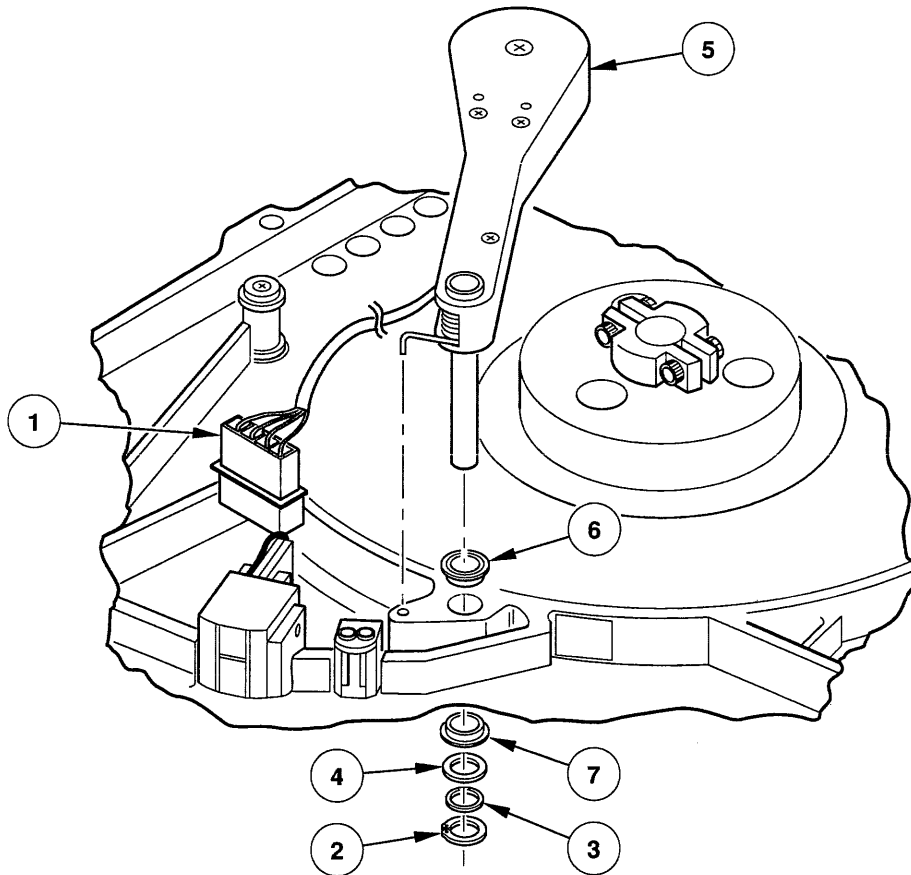

Figure 6-25. Tachometer

Replacement

1. Follow the Removal procedure in reverse order.

If you replace either bearing (6 and 7), apply Loctite 601 to the outside surface of the bearing that contacts the deck plate before installing it.

The purpose of the shims is to allow the snap ring to compress the wavewasher; add or subtract shims so that the wavewasher is compressed approximately 50% when the snap ring is installed.

2. Use Service Aid 11 to check that the tachometer functions properly.

Take-Up Hub

Refer to Figure 6-26 when removing and replacing the take-up hub.

Removal

1. Secure the tachometer (1) away from the take-up hub (2) using tape or string.
2. Loosen the two screws (3) that secure the take-up hub (2) to the take-up motor shaft, then remove the take-up hub.

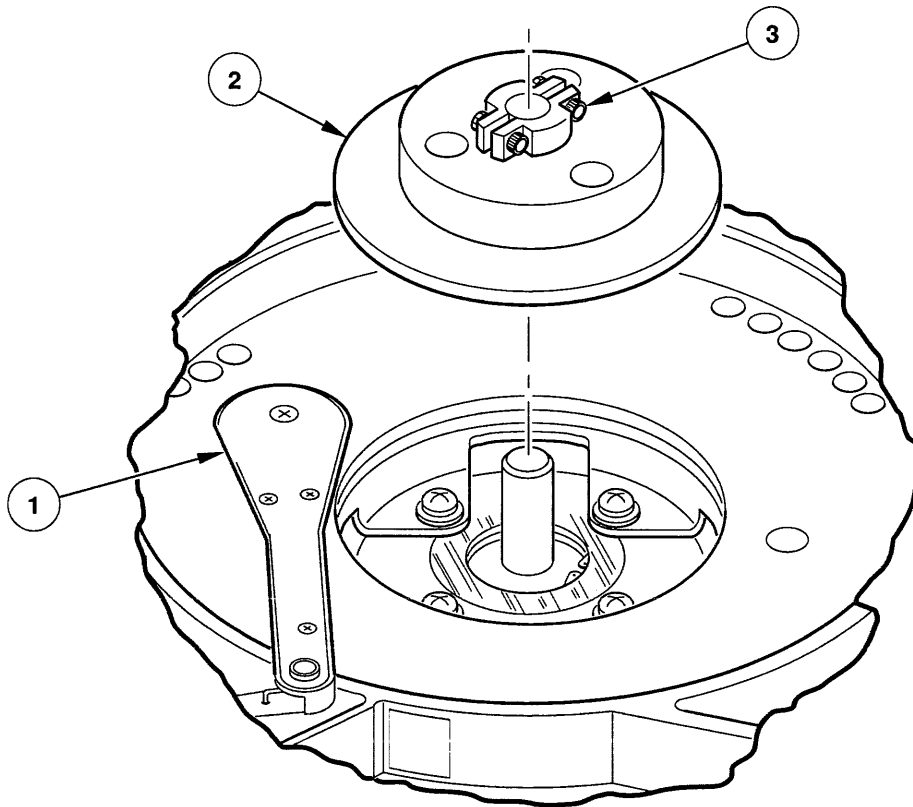

Figure 6-26. Take-Up Hub

Replacement

1. Install the take-up hub (2) on the take-up motor shaft. Do not tighten the two screws (3).
2. Perform the Take-Up Hub Adjustment.

Take-Up Motor

Refer to Figure 6-27 when removing and replacing the take-up motor.

Removal

1. Remove the main circuit board and the take-up hub.
2. Remove the two screws (1) and washers securing the power supply housing cover (2) and remove the cover.
3. Disconnect the take-up motor wires (3) from the motor filter (4).
4. Loosen the four screws (5) securing the take-up motor (6) to the deck plate.
5. Hold the motor (6) while removing the four screws (5) and washers, then remove the motor.
6. Remove the motor insulator (7).

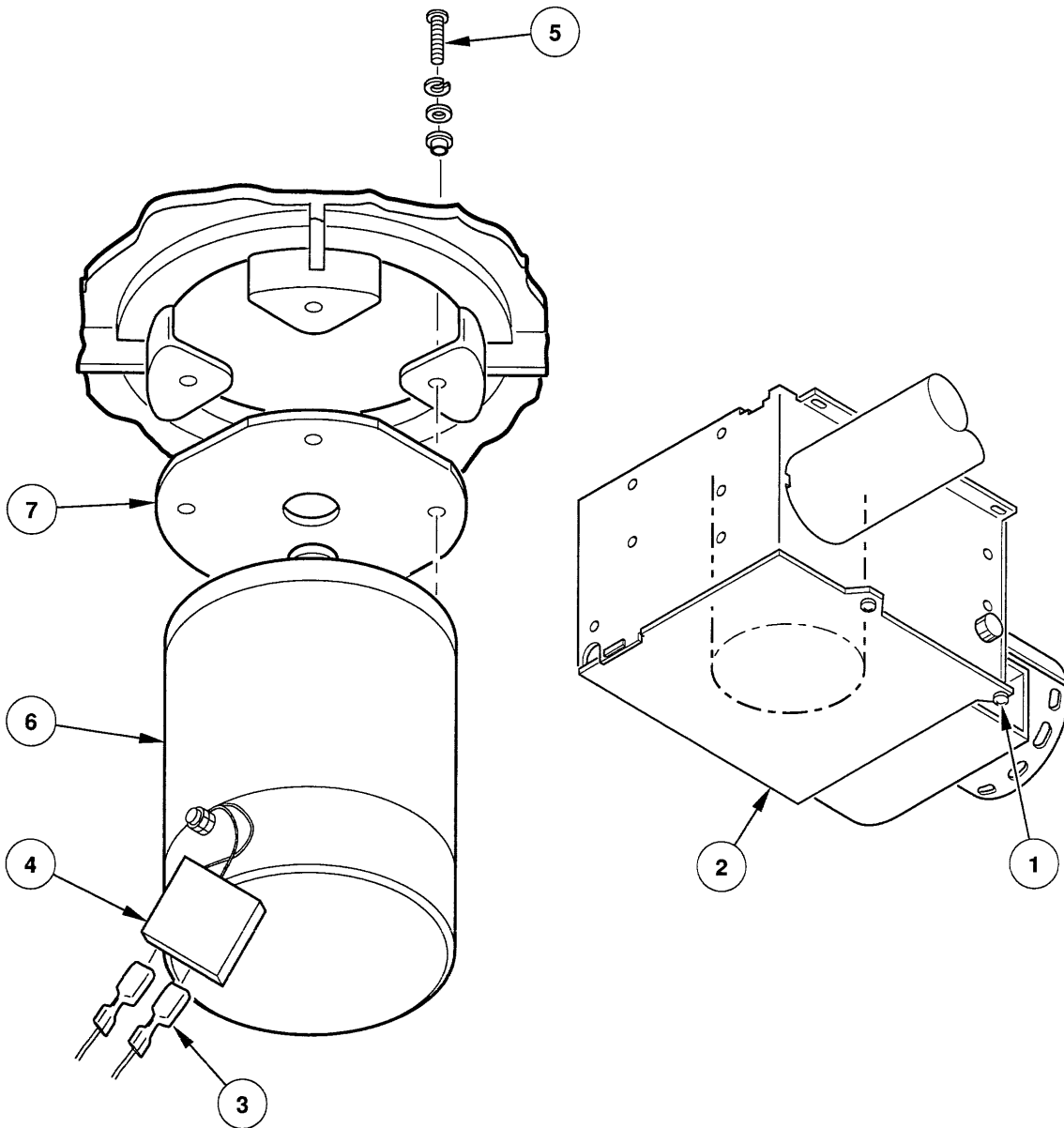

Figure 6-27. Take-Up Motor

Replacement

1. Follow the Removal procedure in reverse order.

Tape-In-Path Receiver

Refer to Figure 6-28 when removing and replacing the tape-in-path sensor.

Removal

1. Disconnect the connector (1) to the tape-in-path receiver (2).
2. Remove the screw (3) and washers securing the tape-in-path receiver (2) to the deck plate, then remove the receiver.

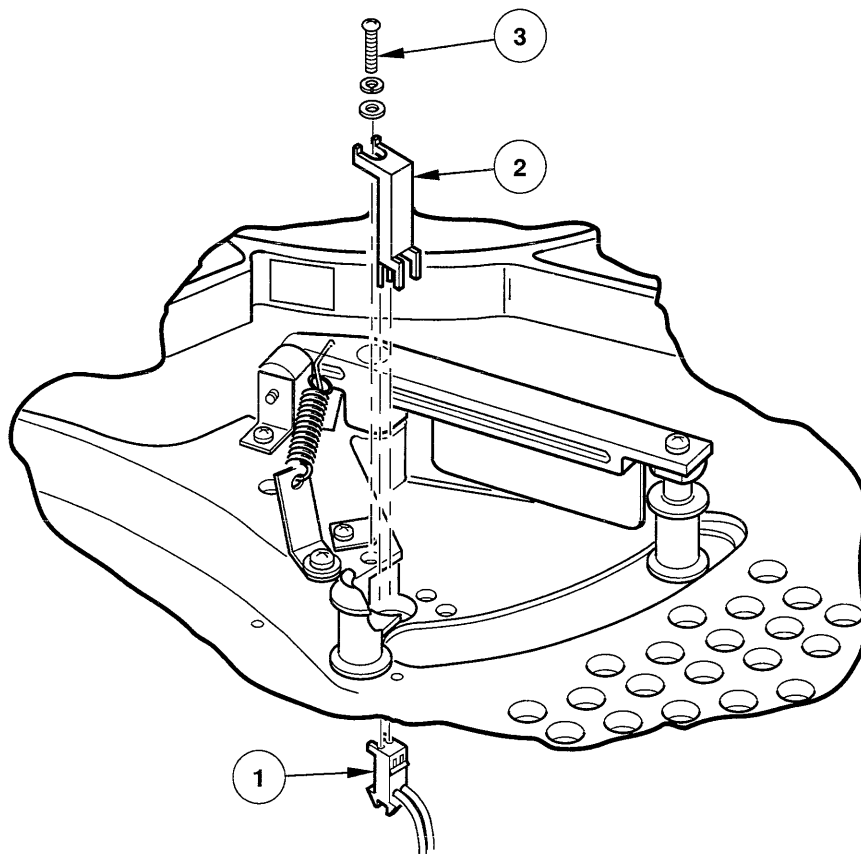

Figure 6-28. Tape-In-Path Receiver

Replacement

1. Follow the Removal procedure in reverse order.
2. Use Service Aid 31 to check that the sensor functions properly.

Tape-In-Path Transmitter

Refer to Figure 6-29 when removing and replacing the tape-in-path transmitter.

Removal

1. Disconnect the connector (1) to the tape-in-path transmitter (2).
2. Remove the two screws (3) and washers securing the tape-in-path transmitter (2) to the deck plate, then remove the transmitter.

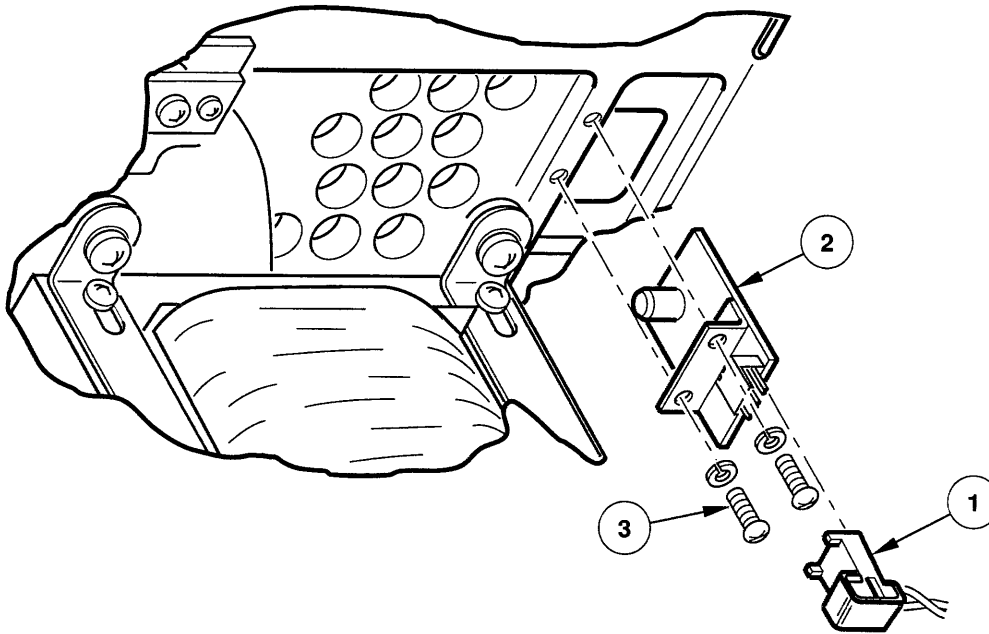

Figure 6-29. Tape-In-Path Transmitter

Replacement

1. Follow the Removal procedure in reverse order.
2. Use Service Aid 31 to check that the sensor functions properly.

Tension Arm, Stator, and Rotor

Refer to Figure 6-30 when removing and replacing the tension arm, stator, and rotor.

Removal

1. Remove the left output air duct.
2. Remove the three wires (1) clipped to the tension arm stator (2).
3. Loosen the screw (3) securing the hub (4) to the shaft of the tension arm (5).
4. Remove the three screws (6) securing the tension arm stator (2) to the deck plate, then remove the stator (2), rotor (7), and hub (4) from the shaft.
5. Disconnect the tension arm spring (8) from the bracket (9).
6. Remove the snap ring (10) securing the tension arm shaft.
7. Remove the tension arm (5).
8. Check whether the upper bearing (11) and lower bearing (12) are damaged. Remove if necessary.

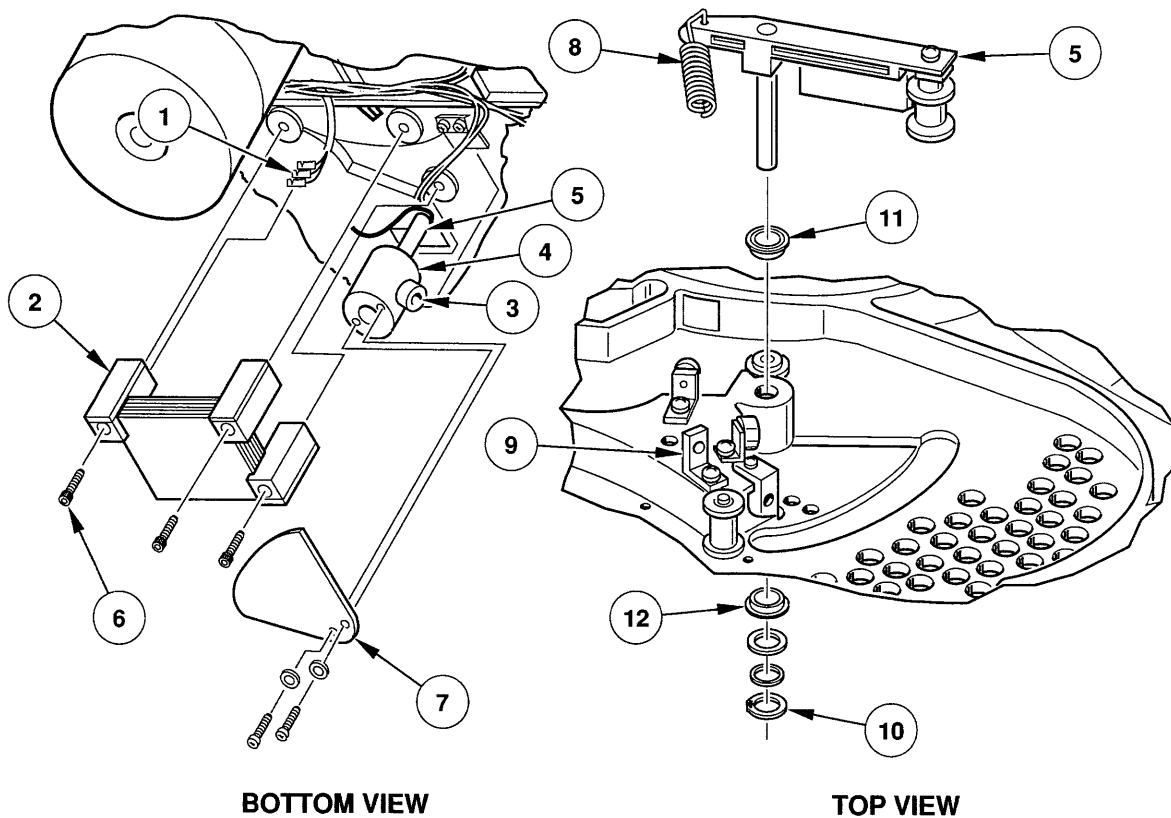

Figure 6-30. Tension Arm

Replacement

1. Follow the Removal procedure in reverse order. But do not tighten the screw (3) securing the hub (4) to the shaft of the tension arm, do not install the tension arm spring (8) to the bracket (9), and do not install the left output air duct.

If you replace either bearing (11 and 12), apply Loctite 601 to the outside surface of the bearing that contacts the deck plate before installing it. The purpose of the shims is to allow the snap ring to compress the wavewasher; add or subtract shims so that the wavewasher is compressed approximately 50% when the snap ring is installed.

The rotor (7) goes between the two plates of the stator (2) that are closest together.

Apply Loctite 242 to the three screws (6) that secure the tension arm stator (2) to the deck plate.

2. Secure the tension arm (5) against the bumper next to roller guide 1.
3. Adjust the hub (4) on the tension arm shaft (5) so the edge of the rotor (7) is approximately 0.1 to 0.2 inches from the power supply housing. Adjust the hub (4) vertically until the rotor (7) is approximately centered between each plate of the stator (2).

4. Tighten the screw (3) to secure the hub (4) on the shaft.
5. Move the tension arm (5) several times between each bumper to check that it moves freely and that the rotor (7) does not rub against either plate of the stator (2); adjust if necessary.
6. Connect the tension arm spring (8) to the bracket (9).
7. Install the left output air duct.
8. Perform the Tension Arm Output Adjustment.
9. Perform the Tape Alignment Adjustment.

Top Cover

Refer to Figure 6-31 when removing and replacing the top cover.

Removal

1. Remove the four screws (1) and washers attaching the top cover (2) to its hinges, then remove the top cover.

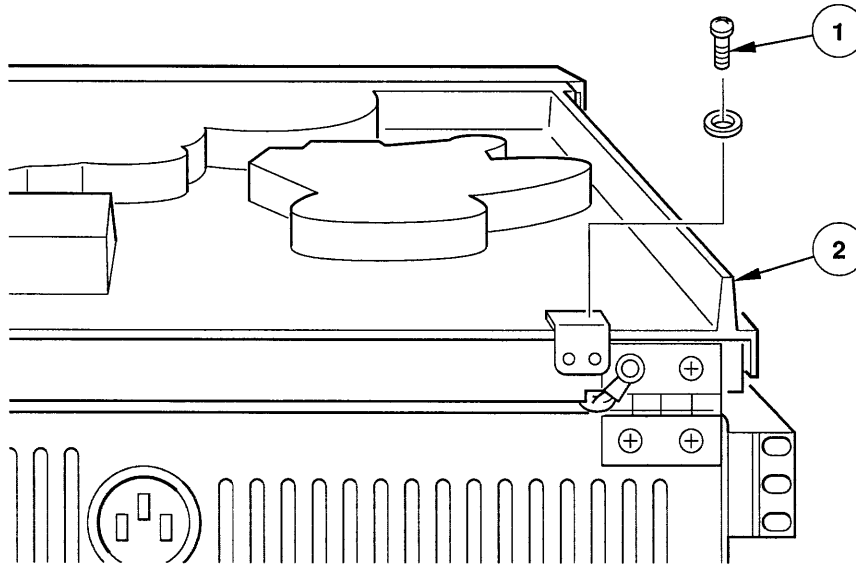

Figure 6-31. Top Cover

Replacement

1. Follow the Removal procedure in reverse order. Be sure the top cover lies flat on the deck plate. The top cover should close with light pressure; if it does not, adjust the two latches at the bottom front of the top cover.
2. Check that the interlock switch is closed when the top cover is down.

Transformer

Refer to Figure 6-32 when removing and replacing the transformer.

Removal

1. Remove the power supply circuit board.
2. Open any tie-wraps securing the transformer (1) cables to the deck plate.
3. Remove the four screws (2) and washers securing the transformer (1) to the deck plate, then remove the transformer.

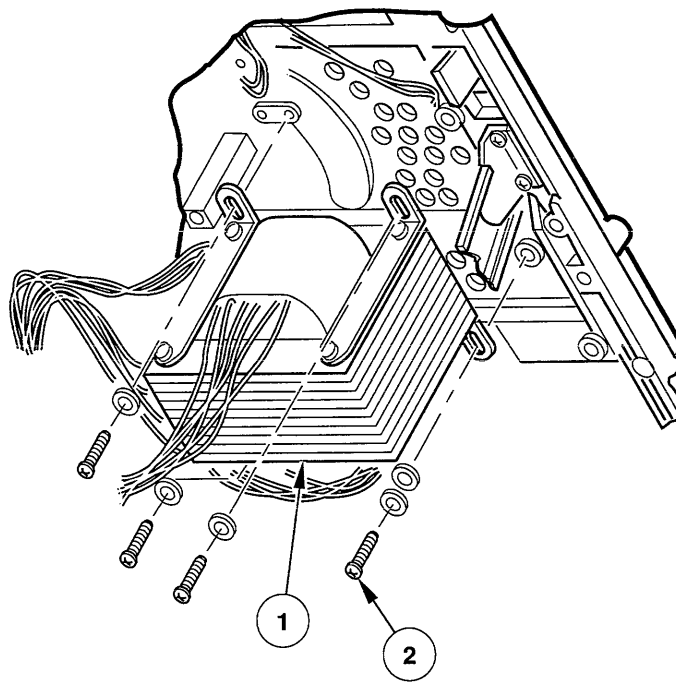

Figure 6-32. Transformer

Replacement

1. Follow the Removal procedure in reverse order.

ADJUSTMENT PROCEDURES

Interlock Disable Procedure

This procedure allows the interlock switch to be disabled for troubleshooting, test, and adjustment purposes. Refer to Figure 6-33.

1. Switch off the tape drive and place it in the operator access position.
2. Insert the interlock disable tool into the interlock switch and turn the tool ninety degrees clockwise.

To reenble the interlock, turn the interlock disable tool ninety degrees counterclockwise and remove it.

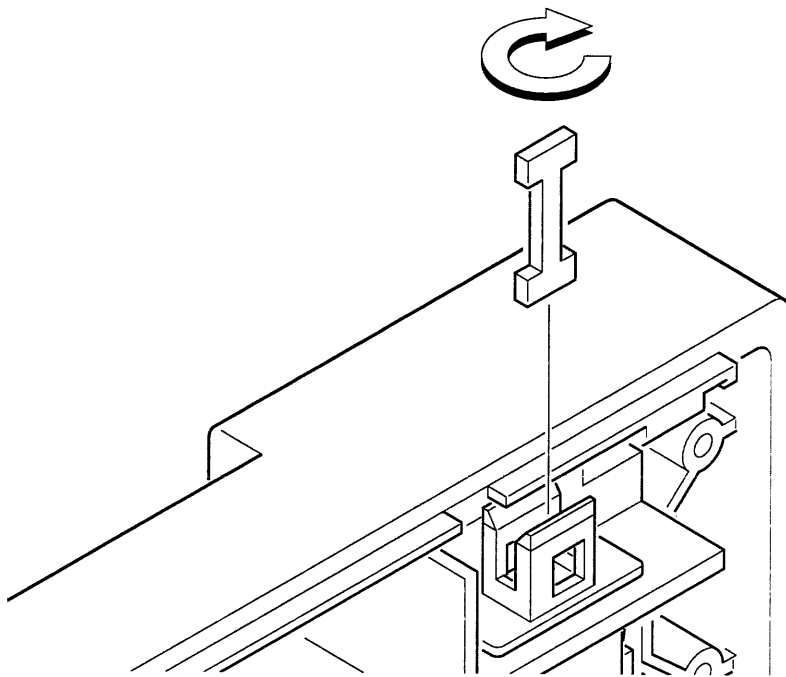

Figure 6-33. Disabling the Interlock

Read Threshold Adjustment

1. Switch on the drive, then load a reference level tape with a write-enable ring.
2. Start Service Aid 21.
3. If the LOAD and UNLOAD LEDs are flashing, or if LOAD stays on and UNLOAD flashes, no adjustment is necessary; go to step 5.
4. If the LEDs are not lighting as required in step 3, turn potentiometer R136, the Read Threshold Potentiometer, (Figure 6-34) clockwise until the LOAD and UNLOAD LEDs are off. Then turn the potentiometer counterclockwise until the requirements of step 3 are met.

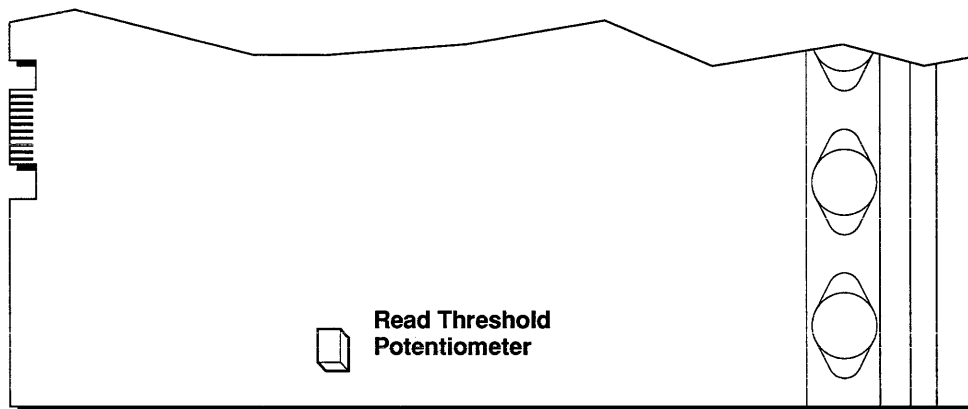

Figure 6-34. Location of Read Threshold Potentiometer

5. Exit the service aid and unload the tape.

Skew Adjustment

1. Switch on the drive and load a master skew tape without a write-enable ring.
2. Connect an oscilloscope to Test Point 14 and to ground (Test Point 18 or 19) on the main circuit board. Set the oscilloscope at 1 volt per division and 2 microseconds.

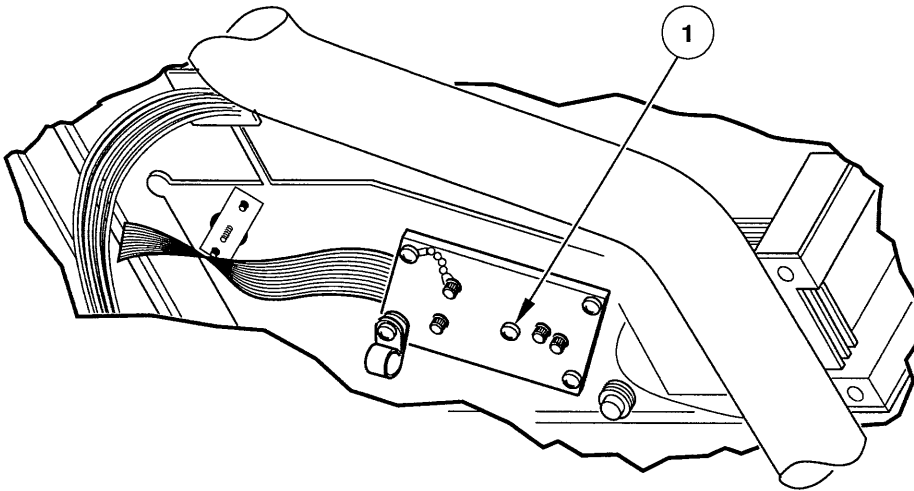

Figure 6-35. Location of Skew Adjustment Screw

3. Start Service Aid 23 and run the tape at 100 inches per second.
4. Turn the skew adjustment screw (1 in Figure 6-35) until the outputs of all tracks fall within 27 percent or less of the byte space, while the tape runs forward then in reverse. See Figure 6-36.

Optimize the forward skew. If, when the forward skew is optimized, the reverse skew exceeds 27 percent of the byte space, either roller guide 5 is improperly shimmed or there is excessive tape shift on roller guide 2 when the tape direction is changed.

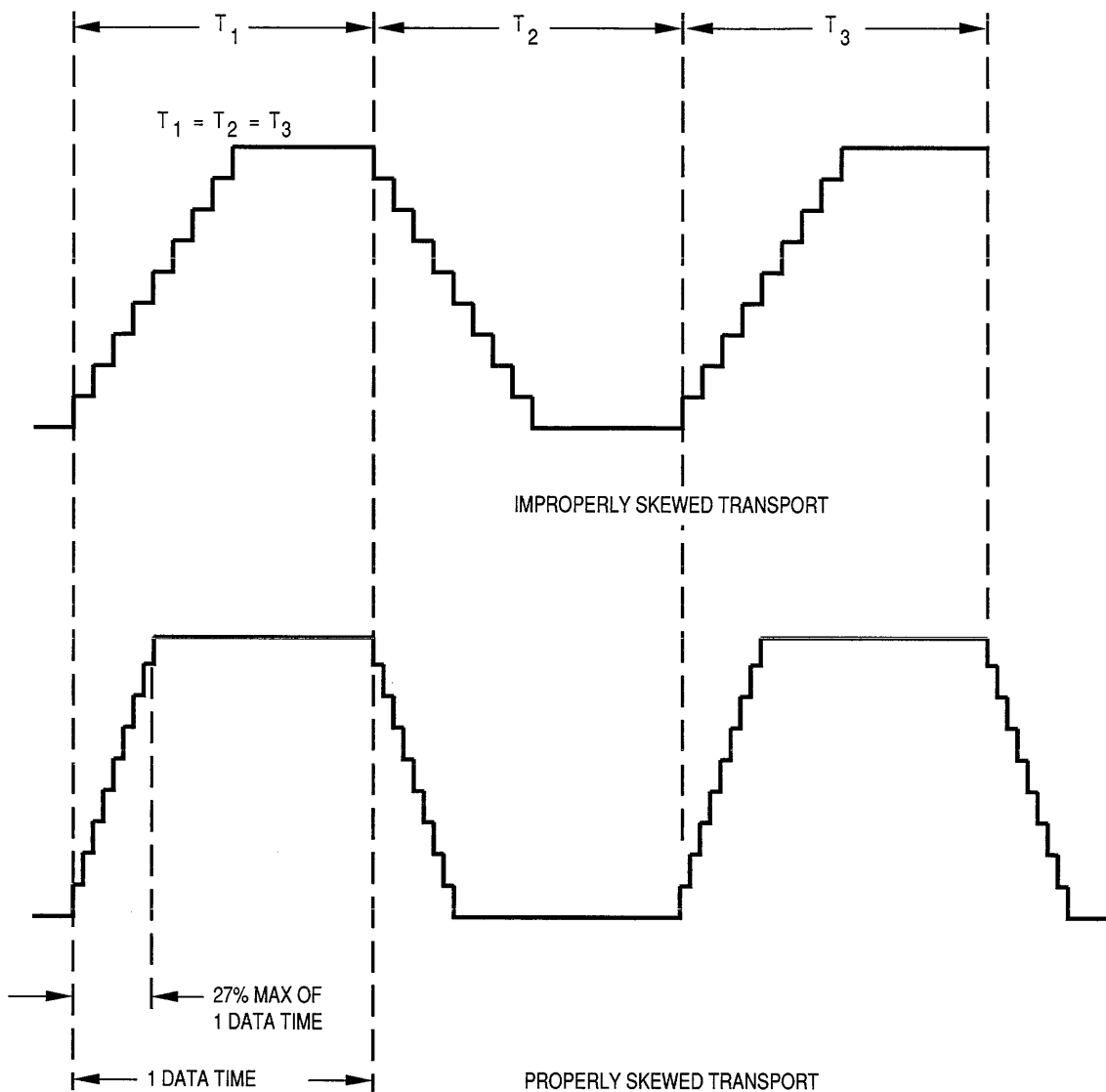

Figure 6-36. Skew Adjustment Waveform

5. Apply torque seal to the skew adjustment screw (1 in Figure 6-35).
6. Check that the skew adjustment is still within specification. If not, go back to step 5.
7. Use Service Aid 23 to unload the master skew tape, then exit the service aid.

Supply Hub Adjustment

1. Loosen the two screws (1) securing the supply hub (2) to the motor shaft.
2. Position a hub-height adjustment tool (3) so that it lies on the deck plate as shown in Figure 6-37.

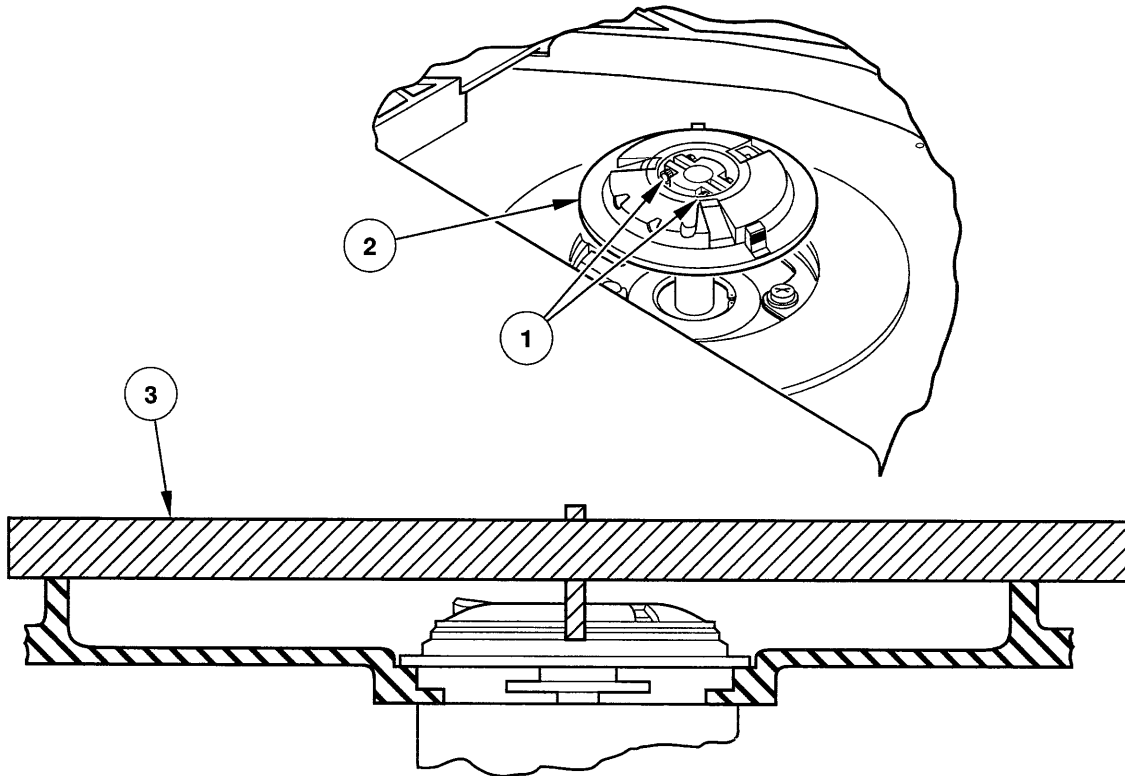

Figure 6-37. Supply Hub Adjustment

3. Raise the supply hub (2) until it contacts the tool, then tighten the two screws (1). This is a coarse reference setting that is 0.672 inches below the raised surface of the top plate. (If you use a ruler or scale instead of a hub-height adjustment tool, adjust the hub so there is 1.0 inches between the supply motor case and the top of the hub.)
4. Remove the hub-height adjustment tool.
5. Load a scratch tape, then run the tape to EOT then back to BOT using Service Aid 23.
6. Check the tape while it is rewinding onto the supply reel. If the tape is approximately centered between the reel's flanges, no further adjustment is required. If the tape is rewinding high or low onto the reel (not centering), unload and remove the tape, and adjust the hub up or down to center the tape. This is a fine adjustment, the tape-to-reel clearance being only 0.005 to 0.047 inches. If this fine adjustment is required, run Service Aid 23 again to ensure the tape centers on the reel.

Take-Up Hub Adjustment

1. Secure the tachometer away from the take-up hub (1) using tape or string.
2. Loosen the two screws (2) securing the take-up hub (1) to the motor shaft.
3. Position a hub-height adjustment tool (3) so that it lies on the deck plate as shown in Figure 6-38.

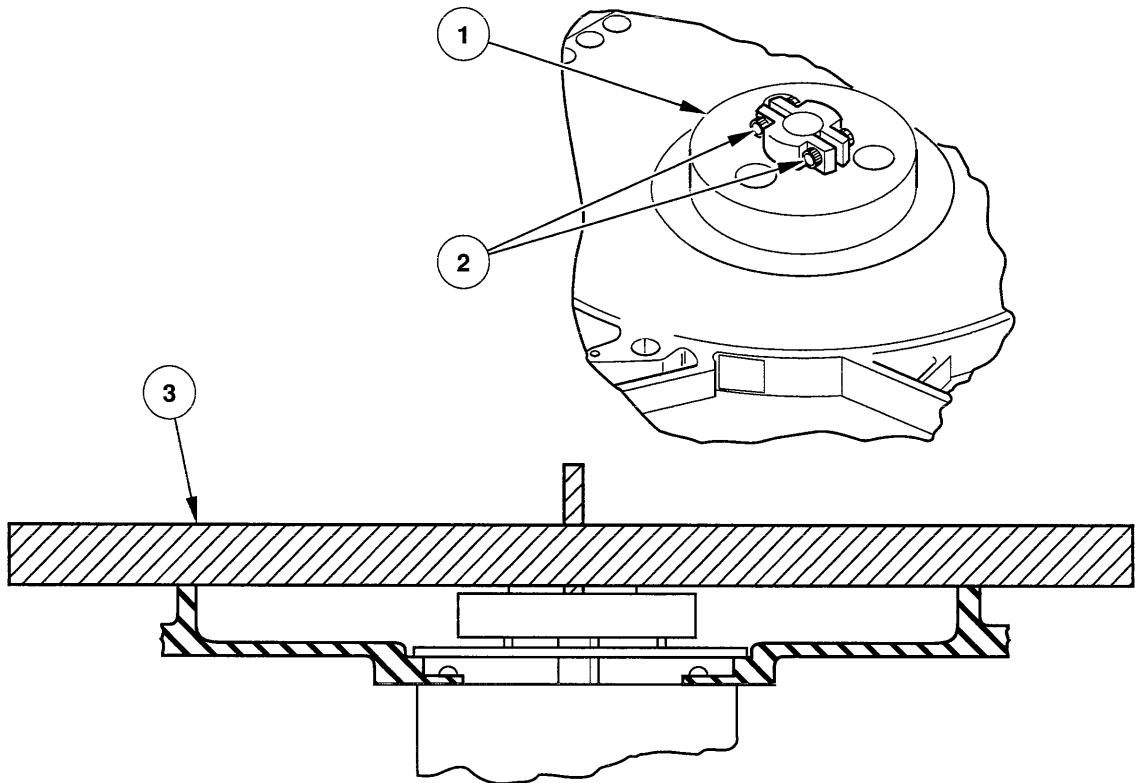

Figure 6-38. Take-Up Hub Adjustment

4. Raise the take-up hub (1) until it contacts the tool, then tighten the two screws (2). This is a coarse reference setting that is 0.045 inches below the raised surface of the top plate. (If you use a ruler or scale instead of a hub-height adjustment tool, adjust the hub so there is 1.5 inches between the take-up motor case and the top of the hub.)
5. Remove the hub-height adjustment tool.
6. Place the tachometer against the hub.
7. Load a scratch tape, then run the tape to EOT using Service Aid 23.
8. Check the tape while it is winding onto the take-up hub. If the tape is approximately centered on the hub, no further adjustment is required. If the tape is winding high or low onto the hub (not centering), unload and remove the tape, and adjust the hub up or down to center the tape. If this fine adjustment is required, run Service Aid 23 again to ensure the tape centers on the hub.

Tape Alignment Adjustment

1. Switch on the drive.
2. Load a scratch tape.
3. Start Service Aid 23.

NOTE

In the following steps, always check for proper tracking with the tape moving forward and in reverse.

4. Observe the tape tracking on roller guide 3. See Figure 1-7 for the locations of each roller guide. Check for curling at the bottom and top edges of the roller guide. The tape tracks best when it runs against the lower part of roller guide 3 without curling. To check for this, press on the lower washer of tape guide 3; the tape should drop from 0.001 to 0.005 inches.

If there is no curl at roller guide 3, go to step 5.

If there is curl on roller guide 3, rewind the tape, switch off the drive, remove roller guide 1, and either add shims to roller guide 1 to remove bottom curl on roller guide 3 or remove shims from roller guide 1 to remove top curl on roller guide 3. Then go back to step 1.

5. Observe the tape tracking on roller guide 2. The tape should be approximately centered on the roller guide.

If the tape is properly centered, go to step 6.

If the tape is not properly centered, rewind the tape, switch off the drive, remove roller guide 2, and either add shims to lower the roller guide or remove shims to raise it. Then go back to step 1.

6. Observe the tape tracking on roller guide 1. Check for curling at the bottom and top edges of the roller guide.

If there is no curling, go to step 7.

If there is curling, rewind the tape, switch off the drive, and perform the Supply Hub Adjustment. Then go back to step 1.

7. Observe the tape tracking on roller guide 4. Check for curling at the bottom and top edges of the roller guide. The tape tracks best when it runs against the lower part of roller guide 4 without curling. To check for this, press on the lower washer of tape guide 4; the tape should drop from 0.001 to 0.005 inches.

If there is no curling, go to step 8.

If there is curling, rewind the tape, switch off the drive, remove roller guide 5, and either add shims to roller guide 5 to remove bottom curl on roller guide 4 or remove shims from roller guide 5 to remove top curl on roller guide 4. Then go back to step 1.

8. Observe the tape tracking on roller guide 5. Check for curling at the bottom and top edges of the roller guide.

If there is no curling, go to step 9.

If there is curling, rewind the tape, switch off the drive, and perform the Take-Up Hub Adjustment. Then go back to step 1.

9. If any roller guides or either hub were adjusted, perform the Skew Adjustment.

Tension Arm Output Adjustment

1. Disable the interlock switch with an interlock disable tool. Start Service Aid 24. Refer to "Service Aid 24" in Chapter 5 if you are not familiar with it.
2. Move the tension arm against the front bumper. Check which LEDs are on and convert that pattern to a voltage using Tables 6-4A and 6-4B. If the voltage is -3.00V or less, go to step 4. If the voltage is greater than -3.00V , go to step 3.
3. Loosen the screw (1) securing the hub to the shaft of the tension arm. See Figure 6-39. Adjust the rotor (2) to decrease the output voltage, then tighten the screw. Go to step 2.

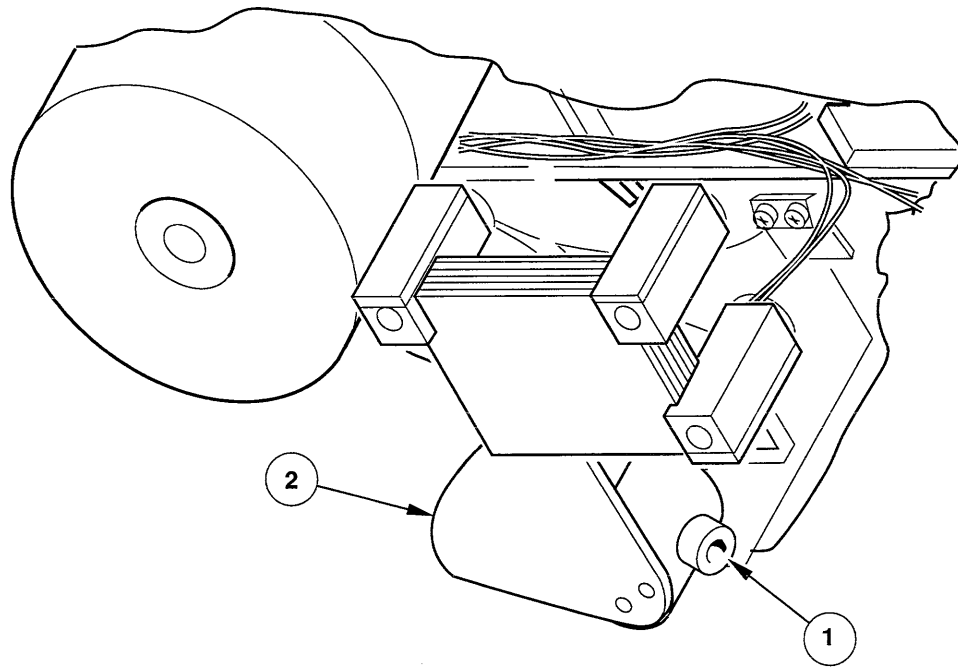

Figure 6-39. Tension Arm Adjustment

4. Allow the tension arm to swing back gently to the rear bumper. Check which LEDs are on and convert that pattern to a voltage using Tables 6-4A and 6-4B. If the voltage is +1.00V or less, go to step 6. If the voltage is greater than +1.00V, go to step 5.
5. Loosen the screw (1) securing the hub to the shaft of the tension arm. Adjust the rotor (2) to decrease the output voltage, then tighten the screw. Go to step 2.
6. Subtract the voltage found in step 2 from the voltage found in step 4. If the voltage difference is between 2.4 and 3.6V, go to step 8. If the voltage is less than or greater than that range, go to step 7.
7. Loosen the screw (1) securing the hub to the shaft of the tension arm. Adjust the rotor (2) to shift the high or low end of the range, then tighten the screw. Go to step 2.
8. Exit Service Aid 24.

LOAD	UNLOAD	ON-LINE	WRT EN	HI DEN	Voltage
0	0	0	0	1	+0.00
0	0	0	1	1	-4.48
0	0	1	0	1	+2.56
0	0	1	1	1	-1.92
0	1	0	0	1	+1.28
0	1	0	1	1	-3.20
0	1	1	0	1	+3.84
0	1	1	1	1	-0.64
1	0	0	0	1	+0.64
1	0	0	1	1	-3.84
1	0	1	0	1	+3.20
1	0	1	1	1	-1.28
1	1	0	0	1	+1.92
1	1	0	1	1	-2.56
1	1	1	0	1	+4.48
1	1	1	1	1	-0.00

Table 6-3A. Value of Tension Arm Output Voltage (HI DEN LED on)

LOAD	UNLOAD	ON-LINE	WR T EN	HI DEN	Voltage
0	0	0	0	0	+ 0.00 or - 0.64
0	0	0	1	0	+ 0.32 or - 0.32
0	0	1	0	0	+ 0.16 or - 0.48
0	0	1	1	0	+ 0.48 or - 0.16
0	1	0	0	0	+ 0.08 or - 0.56
0	1	0	1	0	+ 0.40 or - 0.24
0	1	1	0	0	+ 0.24 or - 0.40
0	1	1	1	0	+ 0.56 or - 0.08
1	0	0	0	0	+ 0.04 or - 0.60
1	0	0	1	0	+ 0.36 or - 0.28
1	0	1	0	0	+ 0.20 or - 0.44
1	0	1	1	0	+ 0.52 or - 0.12
1	1	0	0	0	+ 0.12 or - 0.52
1	1	0	1	0	+ 0.44 or - 0.20
1	1	1	0	0	+ 0.28 or - 0.36
1	1	1	1	0	+ 0.60 or - 0.04

Table 6-3B. Value of Tension Arm Output Voltage (HI DEN LED off)

Tension Arm Spring Adjustment

The position of the tension arm spring bracket is set at the factory and should not be changed unless necessary. If the bracket is replaced or the setting is changed, the following tension arm spring adjustment must be performed.

1. Attach a spring scale to the tension arm (1) by inserting the hook-end of the scale into the notch in the top of the tension arm near the pivot point.
2. Pull the spring scale forward (toward the front panel) until the tension arm roller is between the fourth and fifth rows of holes (from the front panel) in the top plate. The scale must be perpendicular to the tension arm. The scale should indicate 23.5 ± 4.25 ounces. If it does, go to step 4; if it does not, remove the scale and go to step 3.
3. Loosen the screw (2) securing the bracket (3) to the top plate and move the bracket to stretch (increase tension) or shorten (decrease tension) the spring. Tighten the screw, then go to step 1.

4. Remove the spring scale and apply torque seal to the screw (2).
5. Perform the Tension Arm Output Adjustment.

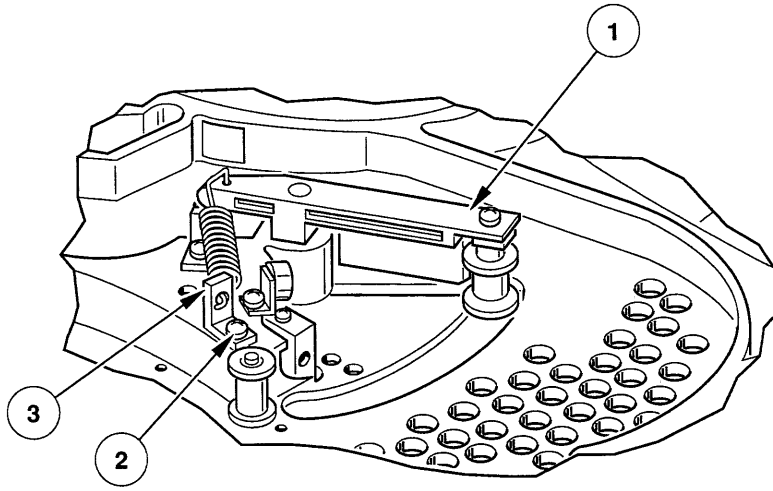

Figure 6-40. Tension Arm Spring Adjustment

Chapter 7 **Small Computer Systems Interface**

INTRODUCTION

This chapter describes the messages, status bytes, and command set of the tape drive's SCSI interface.

SCSI CHARACTERISTICS

The drive supports the following environments:

- Asynchronous data transmission only
- Single and multiple initiators
- Single-ended and differential termination
- Shielded and unshielded connectors
- Initiators that support the arbitration phase and those that do not
- Initiators that support the reselection phase and those that do not
- Interfaces that support parity and those that do not
- Initiators that implement only the mandatory commands and those that implement additional commands
- Initiators that implement the optional messages and those that do not
- Terminator Power can be provided

SIGNALS

The definitions of the SCSI signals are provided below. On single-ended interfaces, signals are active-low. Chapter 2 has tables for the differential and single-ended connectors that show which pins the following signals are assigned.

Acknowledge

The Acknowledge (ACK) signal is set active by an initiator to acknowledge a REQ/ACK data transfer handshake.

Attention

The Attention (ATN) signal is set active by an initiator to indicate the Attention condition.

Busy

Busy (BSY) is an OR-tied signal that indicates the bus is being used.

Control/Data

The Control/Data (C/D) signal is driven by a target to indicate whether control or data information is on the bus. A true signal indicates control.

Data Bus

Eight data-bit signals and a parity-bit signal form the Data Bus (DB0-7, P). DB7 is the most significant bit and has the highest priority during arbitration. Bit number, significance, and priority decrease downward to DB0. Parity is odd.

Input/Output

The Input/Output (I/O) signal is driven by a target to control the direction of data movement on the bus with respect to an initiator. A true signal indicates input to the initiator. It is also used to distinguish between the Selection and Reselection phases.

Message

The Message (MSG) signal is set active by a target during the Message phase.

Request

The Request (REQ) signal is set active by the target to indicate a request for a REQ/ACK data transfer handshake.

Reset

Reset (RST) is an OR-tied signal that indicates the Reset condition.

Select

The Select (SEL) signal is set active by an initiator to select a target or to reselect an initiator.

MESSAGES

The message system provides communication capability between an initiator and a target for managing the physical path. Table 7-1 lists the drive's message set.

Message	Description	Direction
00h	Command Complete	In
02h	Save Data Pointer	In
03h	Restore Pointer	In
04h	Disconnect	In/Out
05h	Initiator Detected Error	Out
06h	Abort	Out
07h	Message Reject	In/Out
08h	No Operation	Out
09h	Message Parity Error	Out
0Ch	Bus Device Reset	Out
80-FFh	Identify	In/Out

In = Target to Initiator; Out = Initiator to Target

Table 7-1. Message Set

STATUS

A status byte is sent by the target to the initiator during the status phase of a data transfer, unless the command was cleared by an Abort message, Bus Device Reset message, a Hard Reset condition, or an unexpected Bus Free Condition. Table 7-2 lists the status byte set.

Status Byte	Description
00h	Good
02h	Check Condition
08h	Busy
18h	Reservation Conflict

Table 7-2. Status Bytes

COMMANDS

The drive is capable of receiving and storing two commands. Further commands are queued in the form of Logical Unit Number and Initiator Identifier. When ready, the drive selects the next command and requests that the initiator send command data. If the command cannot be executed immediately because the drive is active, a Busy status byte is returned to the initiator. In general, no other command can execute while the drive is busy except the Test Unit Ready, Inquiry, and Read Block Limits commands.

Table 7-3 lists the drive's command set.

Command	Code
Copy	18h
Erase	19h
Inquiry	12h
Load/Unload	1Bh
Mode Select	15h
Mode Sense	1Ah
Read	08h
Read Block Limits	05h
Read Reverse	0Fh
Receive Diagnostic	1Ch
Recover Buffered Data	14h
Release Unit	17h
Request Sense	03h
Reserve Unit	16h
Rewind	01h
Send Diagnostic	1Dh
Space	11h
Test Unit Ready	00h
Verify	13h
Write	0Ah
Write File Mark	10h

Table 7-3. Command Set

Command Descriptor Block

The drive supports Group 0 commands. Each command is contained in a Command Descriptor Block (CDB). The first byte of the CDB contains the Command Group Code and Command Code that together make up the Operation Code designating the command. The rest of the CDB contains a Logical Unit Number (LUN), command-dependent information, and a control byte, as shown below in Table 7-4. The tape drive terminates any command without moving the tape or altering data on the tape if there is an invalid parameter in the CDB.

Byte	Bit							
	7	6	5	4	3	2	1	0
00	Command Group Code				Command Code			
01	Logical Unit Number				Command Dependent			
02	Command Dependent							
03	Command Dependent							
04	Command Dependent							
05	Control Byte							

Table 7-4. Command Descriptor Block Format

The Command Group Code is always 000.

The Command Code contains the hexadecimal number for the command.

The Logical Unit Number is always set to 000. However, if the system implements the Identify Message, which is part of the Attention-Identify sequence sent by the initiator, the LUN in the message takes precedence over the LUN in the CDB.

Command Dependent information can include a Logical Block Address, the Transfer Length, the Parameter List Length, or the Allocation Length.

The Logical Block Address contains the Logical Block Address, starting with block zero and continuing up to the last logical block on the tape.

The Transfer Length specifies the maximum number of blocks or bytes of data to be transferred. Commands that use two bytes to describe the Transfer Length allow up to 65,535 blocks of data to be transferred by one command. Several commands use more than two bytes to specify the transfer length. If the transfer length is zero, there is no transfer.

The Parameter List Length sets the length of the command that sends the list of parameters to the target.

The Allocation Length sets the transfer length of the command, which is the number of bytes the initiator has set aside for returned data during the Data In phase.

The Control Byte is the last byte of every CDB. All bits are set to zero. The Flag bit (bit 1) and the Link bit (bit 0) are not supported.

Copy (18h)

The Copy command allows the off-line transfer of data from the drive to another device, or from another device to the drive, without using the initiator's resources. Third-party transfers are not allowed, so the drive must be the source or the destination.

Another SCSI ID must be specified as the source or the destination device. The data is transferred off-line, so the host SCSI controller must support the Disconnect Function or else the Copy command is terminated with an error.

If the tape drive's buffer has data blocks not yet written to tape, the data blocks are written before the Copy command is performed.

The initiator of the Copy command is responsible for correctly positioning sequential devices (tape position) before sending the command and for any external device's error recovery. Because the tape drive functions as either the initiator or the target during the Copy command, normal read and write errors can occur.

If end of data is encountered during a copy where the drive is the source, the Valid bit is set to one and the command is terminated. (The Variable Block Mode also sets the ILI bit to one.) The tape is positioned logically after the last recorded data block or file mark.

The Copy command is always the highest priority relative to other commands.

The contents of the Copy CDB are in Table 7-5.

Byte	Bit							
	7	6	5	4	3	2	1	0
00	0	0	0	1	1	0	0	0
01	Logical Unit Number			0	0	0	0	0
02	Parameter List Length (MSB)							
03	Parameter List Length							
04	Parameter List Length (LSB)							
05	0	0	0	0	0	0	Flag	Link

Table 7-5. Copy Command

The Parameter List Length specifies the number of bytes in the parameters sent during the Data Out phase. This list is sent to the tape drive as data with up to 256 Segment Descriptors, provided they do not exceed the Parameter List Length. With a length of zero no data is sent; this does not cause an error. The Copy Parameter has a Parameter List Header as shown in Table 7-6.

Byte	Bit							
	7	6	5	4	3	2	1	0
00	Copy Function Code					0	0	0
01-03	0	0	0	0	0	0	0	0
02-N	Segment Descriptors							

Table 7-6. Copy Command Parameter List Header

The Copy Function Code defines the type of transfer. The valid codes are:

00h = Direct access to sequential access

01h = Sequential access to direct access

The Segment Descriptors use the Direct Access Device and Sequential Access Device format provided in Table 7-7. This format is required for the Copy command's Function Codes 00h and 01h. The Segment Descriptors can be repeated up to 256 times within the parameter list specified in the descriptor block.

Byte	Bit							
	7	6	5	4	3	2	1	0
00	Source Address			0	0	Source LUN		
01	Destination Address			0	0	Destination LUN		
02	Sequential-Access Device Block Length (MSB)							
03	Sequential-Access Device Block Length (LSB)							
04	Direct-Access Device Number of Blocks (MSB)							
05	Direct-Access Device Number of Blocks							
06	Direct-Access Device Number of Blocks							
07	Direct-Access Device Number of Blocks (LSB)							
08	Direct-Access Device Logical Block Address (MSB)							
09	Direct-Access Device Logical Block Address							
10	Direct-Access Device Logical Block Address							
11	Direct-Access Device Logical Block Address (LSB)							

Table 7-7. Segment Descriptor for Copy Function Codes 00h and 01h

The Source Address specifies the SCSI device sending the data.

The Source LUN identifies the Logical Unit Number of the SCSI device sending data.

The Destination Address specifies the SCSI device receiving the data.

The Destination LUN identifies the Logical Unit Number of the SCSI device receiving the data.

The Sequential-Access Device Block Length identifies the Copy command's block length for the Sequential-Access Device. If the size is recognized as not supported before or during processing, the command is rejected.

The Direct-Access Device Number of Blocks specifies the number of blocks in the current segment. A zero value signifies that no blocks are to be transferred in this segment.

The Direct-Access Device Logical Block Address is the starting address of the blocks to be transferred.

Erase (19h)

The Erase command directs the drive to erase part or all of the remaining tape beginning at the current position.

If the buffer contains data from a previous Write command, the drive is synchronized by writing all data in the buffer to tape before the Erase is executed.

The drive can disconnect from the initiator while executing the Erase command.

The contents of the Erase CDB are in Table 7-8.

Byte	Bit							
	7	6	5	4	3	2	1	0
00	0	0	0	1	1	0	0	1
01	Logical Unit Number			0	0	0	0	Long
02-04	0	0	0	0	0	0	0	0
05	0	0	0	0	0	0	Flag	Link

Table 7-8. Erase Command

With the Long bit set to zero, the drive erases approximately four inches of tape. With the Long bit set to one, the drive erases the remainder of the tape and rewinds to BOT.

Inquiry (12h)

The Inquiry command instructs the drive to transfer data that identifies the drive to the initiator.

If an Inquiry command is received from an initiator with a pending unit attention condition (before the drive reports Check Condition status), the drive performs the Inquiry command and does not clear the unit attention condition.

The contents of the Inquiry CDB are in Table 7-9.

Byte	Bit							
	7	6	5	4	3	2	1	0
00	0	0	0	1	0	0	1	0
01	Logical Unit Number			0	0	0	0	0
02-03	0	0	0	0	0	0	0	0
04	Allocation Length							
05	0	0	0	0	0	0	Flag	Link

Table 7-9. Inquiry Command

The Allocation Length specifies the maximum number of bytes the initiator has allocated for Inquiry data. A zero means no data is to be returned and this is not considered an error. The tape drive terminates the data transfer when the requested amount, or all the data available, has been transferred, whichever is less. The data is listed in Table 7-10.

Byte	Value	Meaning
0	01	Sequential-access device
1	C5	Half-inch reel tape
2	01	ANSI SCSI-1 compliance
3	00	Reserved
4	27	Additional valid bytes
5	C1	Features SCSI extended commands with ECC and SLI
6	XX	Controller microcode change level
7	XX	Controller hardware change level
8-13	CIPHER	Manufacturer code in ASCII
14-27	20	ASCII space character
28-33	F880ES	Model Name in ASCII
34-43	20	ASCII space character

Table 7-10. Inquiry Data

Load/Unload (1Bh)

The Load/Unload command unloads a tape or rewinds it. After the command is received, the drive disconnects from the SCSI bus. If write data is in the buffer, the drive is synchronized by writing all the data in the buffer to tape before this command is executed.

The contents the Load/Unload CDB are in Table 7-11.

Byte	Bit							
	7	6	5	4	3	2	1	0
00	0	0	0	1	1	0	1	1
01	Logical Unit Number			0	0	0	0	Immediate
02-03	0	0	0	0	0	0	0	0
04	0	0	0	0	0	0	Retension	Load
05	0	0	0	0	0	0	Flag	Link

Table 7-11. Load/Unload Command

If set to one, the Immediate bit causes status to be returned immediately. If set to zero, status is returned after the command is executed.

The Retension bit, if set to one, causes the command to rewind the tape to BOT if a reel is loaded and the tape drive is on-line.

The Load bit, if set to one, causes the command to rewind the tape to BOT if a reel is loaded and the tape drive is on-line.

If the Retension and Load bits are zero, the tape is rewound and unthreaded.

Mode Select (15h)

The Mode Select command allows an initiator to set parameters for the drive, including buffered and unbuffered writes to tape and fixed and variable block sizes. If the command is issued with an incorrect Block Descriptor, the drive rejects it.

The contents of the Mode Select CDB are in Table 7-12.

Byte	Bit							
	7	6	5	4	3	2	1	0
00	0	0	0	1	0	1	0	1
01	Logical Unit Number			0	0	0	0	0
02-03	0	0	0	0	0	0	0	0
04	Parameter List Length							
05	0	0	0	0	0	0	Flag	Link

Table 7-12. Mode Select Command

Parameter List Length specifies the number of bytes to be sent to the drive during the Data Out phase. If the drive receives a zero, it does not transfer any data but does not treat the response as an error.

The Parameter List contains the header shown in Table 7-13, followed by the block descriptor shown in Table 7-14, followed by zero or the Page 0 Descriptor shown in Table 7-15.

Byte	Bit							
	7	6	5	4	3	2	1	0
00-01	0	0	0	0	0	0	0	0
02	0	0	0	BUFM	0	0	Speed	
03	0	0	0	0	BDL	0	0	0

Table 7-13. Mode Select Parameter List Header

The BUFM (Buffered Mode) bit is set to one for the Buffered Mode (the default setting) and zero for the Unbuffered Mode. In the Buffered Mode the drive sends a Good status message for write commands as soon as the last data block has been transferred to the buffer. In the Unbuffered Mode the drive does not send a Good status message for write commands until all data has been written to tape.

The Speed bits specify the drive's operating speed.

- 00 = 100 inches per second
- 01 = 25 inches per second
- 10 = 100 inches per second (default)
- 11 = Automatic speed control

Automatic speed control allows the tape drive to run at high speed until six tape underruns occur during consecutive read or write commands. The drive then switches to low speed in an attempt to eliminate the underruns. It remains in low speed until a file mark is written or read, or a different command is issued to the drive. It then switches back to high speed.

The BDL (Block Descriptor Length) bit specifies the length in bytes of the Block Descriptor. If set to zero, there are no Block Descriptors in the parameter list; this is not an error.

Byte	Bit							
	7	6	5	4	3	2	1	0
00	0	0	0	0	Density Code			
01-04	0	0	0	0	0	0	0	0
05	Block Length (MSB)							
06	Block Length							
07	Block Length (LSB)							

Table 7-14. Mode Select Block Descriptor

The Density Code is defined as follows:

- 0h = 1600 bits per inch
- 2h = 1600 bits per inch (default)
- 6h = 3200 bits per inch

The Block Length sets the length in bytes, to a maximum of 64k, of the logical block used for the Fixed Length Block mode. If the Block Length is zero, the length is variable, based on the length specified for each command. The default block length is 200h.

Byte	Bit							
	7	6	5	4	3	2	1	0
00	0	0	0	0	0	0	0	0
01	0	0	0	0	0	0	0	1
02	0	0	0	0	0	0	PER	RDEW

Table 7-15. Mode Select Page 0 Descriptor

The PER (Post Error) bit set to one indicates the drive is to report corrected errors; set to zero (default), it does not report them.

The RDEW (Report Early-Warning End-Of-Medium on Read) bit, if set to one, causes the drive to return Check Condition with the EOM bit in the Extended Sense set to one during a read or a write. If set to zero, the drive reports this only during a write.

Mode Sense (1Ah)

The Mode Sense command allows the drive to report the parameters set by the Mode Select command. The contents of the Mode Sense CDB are in Table 7-16.

Byte	Bit							
	7	6	5	4	3	2	1	0
00	0	0	0	1	1	0	1	0
01	Logical Unit Number			0	0	0	0	0
02-03	0	0	0	0	0	0	0	0
04	Allocation Length							
05	0	0	0	0	0	0	Flag	Link

Table 7-16. Mode Sense Command

The Allocation Length specifies the maximum number of bytes of Mode Sense data to be transferred. If set to zero, no data is transferred; this is not an error.

The Mode Sense Parameter List has a header (Table 7-17). It also has the same Block Descriptor (Table 7-14) and Page 0 Descriptor (Table 7-15) as the Mode Select command.

Byte	Bit							
	7	6	5	4	3	2	1	0
00	0	0	0	0	1	1	1	0
01	0	0	0	0	0	0	0	0
02	WP	0	0	BUFM	0	0	Speed	
03	0	0	0	0	BDL	0	0	0

Table 7-17. Mode Sense Parameter List Header

The WP (Write Protected) bit indicates whether the tape is write-enabled, zero, or write-protected, one.

The BUFM (Buffered Mode) bit is set to one for the Buffered Mode (default) and zero for the Unbuffered Mode. In the Buffered Mode the drive sends a Good status message for write commands as soon as the last data block has been transferred to the buffer. In the Unbuffered Mode the drive does not send a Good status message for write commands until all data has been written to tape.

The Speed bits specify the drive's operating speed. See the Mode Select command section for an explanation of the automatic speed adjustment.

- 00 = 100 inches per second
- 01 = 25 inches per second
- 10 = 100 inches per second (default)
- 11 = Automatic speed adjustment

The BDL (Block Descriptor Length) bit specifies the length in bytes of the Block Descriptor. If set to zero, there are no Block Descriptors in the parameter list; this is not an error.

Read (08h)

The Read command transfers data from the drive to the initiator, starting at the current logical position. The amount of data to be transferred is specified in the CDB.

If a Read command is received with a byte or block count of zero, the command is treated as no operation, with a Complete status returned immediately. No data is transferred and no tape motion is started.

The contents of the Read CDB are in Table 7-18.

Byte	Bit							
	7	6	5	4	3	2	1	0
00	0	0	0	0	1	0	0	0
01	Logical Unit Number			0	0	0	0	FBM
02	Transfer Length (MSB)							
03	Transfer Length							
04	Transfer Length (LSB)							
05	0	0	0	0	0	0	Flag	Link

Table 7-18. Read Command

The FBM (Fixed Block Mode) bit, when set to zero, causes a single block to be transferred with the Transfer Length setting the maximum number of bytes that the initiator has allocated for data. If set to one, data blocks are transferred with the Transfer Length setting the number of blocks. The state of this bit must match the block mode specified in the current Mode Sense data.

In the Variable mode, the Transfer Length sets the maximum block length to be transferred. In the Fixed mode, this parameter specifies the number of blocks of the current block length to transfer to the initiator.

Read Block Limits (05h)

The Read Block Limits command returns the drive's logical block-length limits. The contents of the Read Block Limits CDB are in Table 7-19. The format of the block-length data is in Table 7-20. A value of 0001h is returned for the minimum block length (bytes 04 and 05 of Table 7-20) and a value of 010000h for the maximum block length (bytes 01 to 03 of Table 7-20).

Byte	Bit							
	7	6	5	4	3	2	1	0
00	0	0	0	0	0	1	0	1
01	Logical Unit Number			0	0	0	0	0
02-04	0	0	0	0	0	0	0	0
05	0	0	0	0	0	0	Flag	Link

Table 7-19. Read Block Limits Command

Byte	Bit							
	7	6	5	4	3	2	1	0
00	0	0	0	0	0	0	0	0
01	0	0	0	0	0	0	0	1
02-04	0	0	0	0	0	0	0	0
05	0	0	0	0	0	0	0	1

Table 7-20. Read Block Limits Data

Read Reverse (0Fh)

The Read Reverse command functions exactly like the Read command, except that the tape is read in reverse. In this mode blocks are read from the tape in the opposite direction they were written and are placed in the buffer in the correct character sequence for transfer to the initiator. The amount of data to be transferred is specified in the CDB.

The buffer is checked before the Read Reverse command is executed. If it contains data from a previous Read Forward command, it is cleared and the tape is repositioned before executing the Read Reverse. If it contains data from a previous Write command, the data is written to tape before the Read Reverse is executed.

An End Of Media (EOM) status is returned if BOT is encountered and there were not enough blocks or bytes read to satisfy the Read Reverse command. The residue count contains the number of blocks or bytes not read.

The contents of the Read Reverse CDB are in Table 7-21.

Byte	Bit							
	7	6	5	4	3	2	1	0
00	0	0	0	0	1	1	1	1
01	Logical Unit Number			0	0	0	0	FBM
02	Transfer Length (MSB)							
03	Transfer Length							
04	Transfer Length (LSB)							
05	0	0	0	0	0	0	Flag	Link

Table 7-21. Read Reverse Command

The FBM (Fixed Block Mode) bit, when set to zero, causes a single block to be transferred with the Transfer Length setting the maximum number of bytes that the initiator has allocated for data. If set to one, data blocks are transferred with the Transfer Length setting the number of blocks. The state of this bit must match the block mode specified in the current Mode Sense data.

In the Variable mode, the Transfer Length sets the maximum block length to be transferred. In the Fixed mode, this parameter specifies the number of blocks of the current block length to transfer to the initiator.

Receive Diagnostic (1Ch)

The Receive Diagnostic command causes the drive to return to the initiator the results of specific diagnostic commands sent by the initiator. The command is only executed if a Send Diagnostic command has been processed by the drive. If a Send Diagnostic was not processed, or another command was received since the Send Diagnostics command, the Receive Diagnostic Results command is rejected.

Only the Diagnostic Inquiry (D0) and Test Buffer (D1) functions are supported.

The contents of the Receive Diagnostic CDB are in Table 7-22. The returned information is in Table 7-23.

Byte	Bit							
	7	6	5	4	3	2	1	0
00	0	0	0	1	1	1	0	0
01	Logical Unit Number			0	0	0	0	0
02	0	0	0	0	0	0	0	0
03	Allocation Length (MSB)							
04	Allocation Length (LSB)							
05	0	0	0	0	0	0	Flag	Link

Table 7-22. Receive Diagnostic Command

The Allocation Length specifies the maximum number of bytes the initiator has set for returned diagnostic data. If set to zero, no data is returned. When all the diagnostic data or the maximum specified number of bytes have been transferred, the drive terminates the Data In phase.

Byte	Bit							
	7	6	5	4	3	2	1	0
00	Valid Data Flag							
01	0	0	0	0	0	0	0	0
02	Data Field Length (MSB)							
03	Data Field Length (LSB)							
04	Data Field							
4+N	Extended Sense Length							
4+N+1	Extended Sense Data							

Table 7-23. Receive Diagnostic Results Data

If set to zero, the Valid Data Flag signals that the data returned by the command is valid. If not zero, the data in the Data Field is invalid.

The Data Field Length specifies the amount of data to be returned in the Data Field. The Diagnostic Inquiry Function (D0) returns 64 bytes of data in the Data Field. However, only the first two bytes contain valid data. The value of these bytes is FFFFh. The SCSI controller's buffer is tested by the Test Buffer Function (D1). The Logical Block Offset value is supported. This value is multiplied by the mode-selected block size to obtain the byte offset into the buffer. On a Send Diagnostics command, the data is transferred into the buffer at this offset. On the Receive Diagnostic, the data is then transferred from the buffer to the host.

Extended Sense Length specifies the amount of Extended Sense Data to be returned.

Recover Buffered Data (14h)

The Recover Buffered Data command recovers data that has been transmitted to the buffer, but not yet written to tape. The order of the recovered blocks is the same as if they were written to tape. This command is normally only used to recover from error or exception conditions that make it impossible to write the buffered data to tape. The command functions similarly to the Read command, except that data is transferred from the buffer. The contents of the Recover Buffered Data CDB are in Table 7-24.

Byte	Bit							
	7	6	5	4	3	2	1	0
00	0	0	0	1	0	1	0	0
01	Logical Unit Number			0	0	0	0	FBM
02	Transfer Length (MSB)							
03	Transfer Length							
04	Transfer Length (LSB)							
05	0	0	0	0	0	0	Flag	Link

Table 7-24. Recover Buffered Data Command

If set to zero, the FBM (Fixed Block Mode) bit causes a single block to be transferred with the Transfer Length setting the maximum number of bytes. If set to one, the Transfer Length sets the number of blocks to be transferred.

The Transfer Length, in Variable Mode, specifies the length of the block to be returned, which is the maximum number of bytes allocated by the initiator for returned data. In Fixed Mode, this parameter sets the number of blocks to be transferred from the buffer.

Release Unit (17h)

The Release Unit command is issued by an initiator to release a drive it had previously reserved. An initiator cannot release a drive reserved by another initiator, but an attempt to release a non-reserved drive does not cause an error. A drive cannot disconnect from an initiator during the execution of the command. The contents of the Release Unit CDB are in Table 7-25.

Byte	Bit							
	7	6	5	4	3	2	1	0
00	0	0	0	1	0	1	1	1
01	Logical Unit Number			Third Party Release & ID				0
02-04	0	0	0	0	0	0	0	0
05	0	0	0	0	0	0	Flag	Link

Table 7-25. Release Unit Command

The Third Party Release and ID bits are not supported.

Request Sense (03h)

The Request Sense command obtains Sense information from the drive, usually when the initiator has received a Check Condition status byte from a previous command.

When a Check Condition is returned, the Sense data is saved in the drive. It is not cleared until a Request Sense command is received or an initiator issues another command that receives the Check Condition status. A Request Sense command can be issued at any time.

The contents of the Request Sense CDB are in Table 7-26.

Byte	Bit							
	7	6	5	4	3	2	1	0
00	0	0	0	0	0	0	1	1
01	Logical Unit Number			0	0	0	0	0
02-04	Allocation Length							
05	0	0	0	0	0	0	Flag	Link

Table 7-26. Request Sense Command

The Allocation Length provides the number of bytes allocated by the initiator for Sense data. The length determines the format of the returned Sense data. If the length is zero, the first four bytes of Extended Sense data are transferred. Any other value represents the maximum defined number of Sense bytes to be transferred.

Data is transferred in the Extended Sense format. The required portion of the Extended Sense data is in Table 7-27. The optional portion is in Table 7-28 for the Copy command and 7-29 for other commands.

Byte	Bit							
	7	6	5	4	3	2	1	0
00	Valid	1	1	1	0	0	0	0
01	Segment Number							
02	File Mark	EOM	ILI	0	Sense Key			
03	Information Bytes (MSB)							
04	Information Bytes							
05	Information Bytes							
06	Information Bytes (LSB)							
07	Additional Sense Length							

Table 7-27. Extended Sense Data for All Commands, Bytes 0-7

When one, the Valid bit indicates that the Information Bytes contain valid data.

The Segment Number contains the current segment number (0-256) if the Extended Sense is in response to a Copy command. For all other commands this byte is zero.

The File Mark bit, if set to one, indicates that a file mark was detected.

The EOM (End of Medium) bit indicates that if the drive is moving tape forward it has reached EOT. If the drive is moving tape in reverse, the command could not be completed because it reached BOT.

The ILI (Incorrect Length Indicator) bit indicates the requested logical block length did not match the logical block length of the data on the tape.

The Sense Key provides the status of errors found during operation. See Table 7-30.

The Information Bytes, if set to zero, are not defined. If set to one, the bytes contain the residue (difference) in bytes or blocks between the requested and the actual data length transferred, or the difference between the requested number of blocks and the number of blocks copied for the current segment descriptor of a Copy command. Negative values are indicated by twos-complement notation.

The Additional Sense Length specifies the number of additional Extended Sense data bytes to follow. If the allocation length of the CDB is too small to permit the transfer of all the Extended Sense data, the Additional Sense Length is not adjusted to reflect the truncation. The Additional Sense Data further define the Check Condition status, as shown in Tables 7-28 (for the Copy command) and 7-29 (for all commands other than Copy).

Byte	Bit							
	7	6	5	4	3	2	1	0
08	Relative Byte Offset to Source's Status							
09	Relative Byte Offset to Destination's Status							
10	Completion Status							
11	Valid	1	1	1	0	0	0	0
12	0	0	0	0	0	0	0	0
13	File Mark	EOM	ILI	0	Sense Key			
14	Information Bytes (MSB)							
15	Information Bytes							
16	Information Bytes							
17	Information Bytes (LSB)							
18	Additional Sense Bytes							
19-N	Device Specific Sense Data							
N+1- N+6	Copy CDB							
N+7- N+10	0	0	0	0	0	0	0	0
N+11- N+14	Copy Parameter List Header							
N+15- N+26	Copy Segment Descriptor List							

Table 7-28. Extended Sense Data for a Copy Command

The Relative Byte Offset to Source's Status provides the relative byte offset position for the first byte of the Copy command's Sense Data for the source.

The Relative Byte Offset to Destination's Status provides the relative byte offset position for the first byte of the Copy command's Sense Data for the destination.

The Valid bit, if set to one, indicates that bytes 4-17 contain valid Sense Information.

The File Mark bit, if set to one, indicates that a file mark was detected.

The EOM (End of Medium) bit indicates that if the drive is moving the tape forward, it has reached EOT. If the drive is moving the tape in reverse, the command could not be completed because it reached BOT.

The ILI (Incorrect Length Indicator) bit indicates the requested logical block length did not match the logical block length of the data on the tape.

Sense Key indicates the status of errors found during operation. See Table 7-30.

Byte	Bit							
	7	6	5	4	3	2	1	0
08-11	0	0	0	0	0	0	0	0
12-14	Additional Sense Codes							
15	0	0	0	0	0	0	0	0
16-19	1	1	1	1	1	1	1	1
20	0	0	0	0	0	REACT	0	0
21	Retry Count							
22	1	1	1	1	1	1	1	1
23	HERR	CERR	FMK	IDENT	EOT	BOT	FBY	DBY
24	RDY	FPT	SPEED	ONL	0	REW	Drive Number	
25	Tape Status Port							
26	DMA Status Port							
27-36	Command Descriptor Block							
37-40	Parameter List Header							
41-48	Block Descriptor List							
49-60	0	0	0	0	0	0	0	0

Table 7-29. Extended Sense Data for a Non-Copy Command

The Additional Sense Codes are in Table 7-31.

The REACT (Recovery Action) bit indicates no action is taken if set to zero. If set to one, the specified number of retries is attempted.

The Retry Count indicates the number of retries attempted.

The HERR (Hard Error) bit indicates a hard error.

The CERR (Corrected Error) bit indicates a corrected error.

FMK (File Mark) indicates a file mark was detected.

The **IDENT (Identification)** bit indicates the identification burst was detected.

EOT indicates End Of Tape.

BOT indicates Beginning Of Tape.

The **FBY (Formatter Busy)** bit indicates the formatter is busy, i.e., tape moving.

DBY (Data Busy) indicates a command is in progress.

The **RDY (Ready)** bit indicates the tape is loaded and ready; it is not used during write commands.

FPT (File Protect) indicates the tape is write-protected.

The **SPEED** bit indicates 100 inches per second when set to one and 25 inches per second when set to zero.

The **ONL (On-Line)** bit indicates whether the drive is on-line (one) or off-line (zero).

REW (Rewind) indicates the drive is rewinding the tape.

The two **Drive Number** bits indicate the drive unit number.

The **Tape Status Port** provides status. See Table 7-32.

The **DMA Status** provides status. See Table 7-33.

The **Command Descriptor Block** repeats the CDB of the command that caused the error.

The **Parameter List Header** repeats the Header of the command that caused the error when the command is a Mode Select. Not used for other commands (all bytes are zero).

The **Block Descriptor List** repeats the List for a Mode Select command. Not used for other commands (all bytes are zero).

Hex Code	Sense Key	Explanation
0	No Sense	No Sense Key data to be reported.
1	Recovered Error	Command completed successfully with some recovery action.
2	Not Ready	Target cannot be accessed.
3	Medium Error	Command terminated with an unrecovered error probably due to the medium.
4	Hardware Error	Target detected a non-recoverable hardware fault.
5	Illegal Request	Illegal parameter in CDB or in additional parameters.
6	Unit Attention	Medium may have been changed or the target has been reset.
7	Data Protect	A read or write was attempted on data protected from that operation.
8	Blank Check	A read past End of Data was attempted.
9	Reserved	
A	Copy Aborted	Copy command aborted due to an error by the source or destination device.
B	Aborted Command	Target aborted a command.
C	Reserved	
D	Volume Overflow	Drive reached EOT and unwritten data remains in the buffer.
E	Reserved	
F	Reserved	

Table 7-30. Sense Keys

Hex Code	Additional Sense Code
00	No additional Sense information
20	Illegal command
43	Data buffer parity error
4B	Power-up failure
51	Function time-out
52	Tape position error
53	Error occurred before command completion
54	Data buffer not empty
55	Fixed mode bit incorrectly set
56	Data transfer error: host to controller
57	Data transfer error: controller to host
58	Verify command with byte compare not supported
59	Space to EOD not supported
5B	Command sequence error
5C	Unit select error
5D	Variable block length greater than 64k
5E	Unable to obtain buffer
5F	Command parameter error
60	Status error from target
61	Copy failed: host cannot disconnect
62	Controller detected retries: buffer parity
63	Controller detected retries: SCSI parity
64	Controller detected tape retries

Table 7-31. Additional Sense Codes

Bit	Description
7	Tape TC (for level 0 diagnostics)
6	SCSI TC (for level 0 diagnostics)
5	Block underrun
4	SCSI DMA-generated parity (used for level 0 diagnostics)
3	Tape overrun
2	Parity in (used for level 0 diagnostics)
1	Tape DMA parity error
0	SCSI DMA parity error

Table 7-32. Tape Status Port 3

Bit	Description
7	Tape DMA length terminal count (active low)
6	SCSI DMA length terminal count (active low)
5	Manual SCSI DMA request (for level 0 diagnostics)
4	Manual tape DMA request
3	Dynamic RAM refresh enable (active low)
2	SCSI to tape
1	Tape DMA enable
0	SCSI DMA enable

Table 7-33. DMA Status

Reserve Unit (16h)

The Reserve Unit command reserves the drive for the exclusive use of the requesting initiator. Once in force, any attempt by another initiator to reserve the same drive returns a Reservation Conflict status message. The command stays in effect until the drive is released by the requesting initiator, a Bus Device Reset message is received, or a Hard Reset occurs.

The contents of the Reserve Unit CDB are in Table 7-34.

Byte	Bit							
	7	6	5	4	3	2	1	0
00	0	0	0	1	0	1	1	0
01	Logical Unit Number			Third Party Reserve & ID				0
02-04	0	0	0	0	0	0	0	0
05	0	0	0	0	0	0	Flag	Link

Table 7-34. Reserve Unit Command

The Third Party Reserve and ID bits are not supported.

Rewind (01h)

The Rewind command rewinds the tape to BOT. If the Disconnect function is enabled, the drive disconnects from the initiator during the operation. If the buffer contains write data, the drive synchronizes the buffer by writing the data to tape before rewinding. If the buffer contains read data from a previous read command to the same initiator, the buffer is cleared; if it contains read data from another initiator, the data is preserved. The contents of the Rewind CDB are in Table 7-35.

Byte	Bit							
	7	6	5	4	3	2	1	0
00	0	0	0	0	0	0	0	0
01	Logical Unit Number			0	0	0	0	Immediate
02-04	0	0	0	0	0	0	0	0
05	0	0	0	0	0	0	Flag	Link

Table 7-35. Rewind Command

The Immediate bit, if zero, causes a status message to be returned after the rewind is completed. If the bit is one, status is returned as soon as the rewind is initiated.

Send Diagnostic (1Dh)

The Send Diagnostic command causes the drive to execute a diagnostic test. The results of the diagnostic are stored by the drive. The initiator requests the results with the Receive Diagnostic command. The contents of the Send Diagnostic CDB are in Table 7-36.

Byte	Bit							
	7	6	5	4	3	2	1	0
00	0	0	0	1	1	1	0	1
01	Logical Unit Number			0	0	Self Test	DevOfL	UnitOfL
02	0	0	0	0	0	0	0	0
03	Parameter List Length (MSB)							
04	Parameter List Length (LSB)							
05	0	0	0	0	0	0	Flag	Link

Table 7-36. Send Diagnostic Command

If the Self Test bit is set to one and the parameter list is zero, the drive returns Good status.

A DevOfL (Device Off-Line) bit of one enables diagnostic operations that may adversely affect operations to other logical units on the same target.

A UnitOfL (Unit Off-Line) bit of one enables diagnostic operations that may adversely affect operations to other logical units on the same target.

Parameter List Length specifies the length in bytes of the parameter list to be transferred. A length of zero indicates that no data will be transferred; this is not considered an error.

The format for the Send Diagnostic Data sent by the initiator as part of the Send Diagnostic command is in Table 7-37.

Byte	Bit							
	7	6	5	4	3	2	1	0
00	Diagnostic File Length (MSB)							
01	Diagnostic File Length (LSB)							
02	0	0	0	0	0	0	0	0
03	Diagnostic Function Code							
04-05	0	0	0	0	0	0	0	0
06	Block Offset Value (MSB)							
07	Block Offset Value (LSB)							
08	Data Field Length (MSB)							
09	Data Field Length (LSB)							
10 + N	Data Field							

Table 7-37. Send Diagnostic Data

Diagnostic File Length specifies the number of bytes belonging to the diagnostic parameter.

Diagnostic Function Code sets the diagnostic function to be executed. Diagnostic Inquiry function (D0h) returns information about the SCSI controller. Test Buffer function (D1h) tests the SCSI controller's buffer when it is empty. The Test Buffer function can only be issued when the buffer is empty unless the Device or the Unit Off-Line bit is set. If either of these bits is set to one and data remains in the buffer, the data is destroyed.

The Block Offset Value sets the offset value for the Test Data Buffer function (D1h). This value is multiplied by the current Mode Sense block size to find the offset in bytes. On a Send Diagnostic command, data is transferred to the buffer, starting at this offset. On the subsequent Receive Diagnostic command, the data is returned, starting at this offset.

The Data Field Length specifies the amount of data to be transferred to the buffer. The Data Field contains the actual data transferred to this buffer.

Space (11h)

The Space command positions the head and tape relative to a specific data block, a data block following a specific file mark, or a data block following a specific series of file marks. The Space command can change the current logical position by moving the tape forward or reverse from the current tape position. Movement is logically restricted to the current tape.

If there is write data in the buffer, the drive synchronizes the buffer by writing all blocks in the buffer to tape before performing the space operation.

The contents of the bytes in the Space CDB are listed in Table 7-38. If the command is received with a count of zero in the Count Bytes, the command is treated as no operation.

Byte	Bit							
	7	6	5	4	3	2	1	0
00	0	0	0	1	0	0	0	1
01	Logical Unit Number			0	0	0	Code	
02	Sign			Count (MSB)				
03	Count							
04	Count (LSB)							
05	0	0	0	0	0	0	Flag	Link

Table 7-38. Space Command

The Code bits specify the space operation as follows:

- 00 = Data Blocks
- 01 = File Marks
- 10 = Sequential File Marks
- 11 = Not supported

When the Sign bit is positive, motion is logically forward. When it is negative, motion is logically reverse.

The Count bytes specify the number of file marks or data blocks to space over. A count of zero does not cause motion.

Test Unit Ready (00h)

The Test Unit Ready command returns the status of the drive. It causes a fast test to determine whether the drive is powered on, ready, and tape is loaded. The contents of the Test Unit Ready CDB are in Table 7-39.

Byte	Bit							
	7	6	5	4	3	2	1	0
00	0	0	0	0	0	0	0	0
01	Logical Unit Number			0	0	0	0	0
02-04	0	0	0	0	0	0	0	0
05	0	0	0	0	0	0	Flag	Link

Table 7-39. Test Unit Ready Command

Verify (13h)

The Verify command allows one or more data blocks, starting at the current position, to be checked without transferring the data to the initiator. The data to be verified is located in bytes two through four of the CDB.

If the buffer contains write data, the drive synchronizes the buffer by writing the blocks to tape before beginning the verify.

The contents of the Verify CDB are in Table 7-40.

Byte	Bit							
	7	6	5	4	3	2	1	0
00	0	0	0	1	0	0	1	1
01	Logical Unit Number			0	0	0	BytCmp	FBM
02	Verification Length (MSB)							
03	Verification Length							
04	Verification Length (LSB)							
05	0	0	0	0	0	0	Flag	Link

Table 7-40. Verify Command

The BytCmp (Byte Compare) bit is not supported.

The FBM (Fixed Block Mode) bit verifies the next block if set to zero. If set to one, it requests that the number in the Verification Length be verified starting with the next logical block.

The Verification Length specifies the number of bytes to verify in the variable block mode. In the fixed block mode, it specifies the number of blocks to verify.

Information Content Errors

For all errors, unless otherwise stated, the Information Bytes of the Extended Sense are set when in Variable Block Mode to a value equal to the difference between the requested Verification Length and the actual block length; in Fixed Block Mode, the Information Bytes are set to a value equal to the difference between the requested verification length and the actual number of blocks verified, excluding the block in error.

Block Length Errors

If the actual block length in the Variable Block Mode is greater than the value set in the Verification Length, no more than the transfer length is verified. If a verification on a block longer or shorter than the set length is attempted in Fixed Block Mode, the Valid and Illegal Length Indicator bits are set to one and the command is terminated; the logical position is immediately after the incorrect length block.

File Mark Errors

When a file mark is read, the Valid and File Mark bits are set to one and the command is terminated. The Variable Block Mode also sets the Illegal Length Indicator bit.

End Of Data Errors

If End Of Data is encountered, the Valid bit is set to one and the command is terminated with a Blank Check Sense Key. If the Variable Block Mode is in effect, the Illegal Length Indicator bit is also set to one; the logical position is immediately after the last recorded element, whether a data block or a file mark.

End of Tape Errors

When EOT is encountered, the EOM bit is set to one and the command is terminated; the logical position is indeterminate.

Unrecovered Data Errors

If a data error is detected and not corrected, the command is terminated; the logical position is immediately after the erroneous block.

Recovered Data Errors

If a data error is detected and corrected, the command is completed. If the Post Error bit is one, a Recovered Error Sense Key is returned; if the Post Error bit is zero, the Recovered Error Sense Key is suppressed.

Write (0Ah)

The Write command transfers a specified number of blocks from an initiator to the drive and writes those blocks to tape. Data blocks can be fixed or variable length as specified in the Mode Select command. Writing can be buffered or unbuffered, which is also specified by the Mode Select command. If buffered, a status message is returned when the data for the last block is placed in the buffer. If unbuffered, a status message is not returned until the last block has been written to the tape. Unbuffered writes prevent the drive from streaming. A Write command following EOT is always written in the unbuffered mode.

A Media Error Sense Key is issued for any unrecoverable data errors. The drive tries rewriting the data before this error is returned. Before each retry, it repositions over the bad block and erases one foot of tape. The Extended Sense data includes a residue count, the drive status bytes, and a retry count (number of retries that have occurred since the last file mark written or since BOT). The residue count consists of all blocks (fixed) or bytes (variable) in the buffer plus those not yet transferred to the buffer. Recoverable write errors are not reported until a file mark is written.

The contents of the Write CDB are in Table 7-41.

Byte	Bit							
	7	6	5	4	3	2	1	0
00	0	0	0	0	1	0	1	0
01	Logical Unit Number			0	0	0	0	FBM
02	Transfer Length (MSB)							
03	Transfer Length							
04	Transfer Length (LSB)							
05	0	0	0	0	0	0	Flag	Link

Table 7-41. Write Command

If set to zero, the FBM (Fixed Block Mode) bit causes a single block to be written with the Transfer Length specifying the maximum number of bytes. If set to one, the Transfer Length specifies number of blocks.

The Transfer Length specifies the length of the blocks to be written in Variable Block Mode. In Fixed Block Mode it specifies the number of blocks of the current length to be written.

Information Content Errors

For all errors, unless otherwise stated, the Information Bytes of the Extended Sense are set when in Variable Block Mode to a value equal to the difference between the requested Transfer Length and the actual number of bytes written. When in the unbuffered Fixed Block Mode, the Information Bytes are set to a value equal to the difference between the requested Transfer Length and the actual number of blocks written. In the buffered Fixed Block Mode, the Information Bytes are set to a value equal the total number of blocks not transferred from the initiator plus the number of blocks remaining in the buffer.

Block Length Errors

In the Variable Block Mode when the Transfer Length exceeds the maximum allowable value specified in the Read Block Limits data, the command is rejected with an Illegal Request Sense Key.

End Of Medium Errors

If EOT is encountered, all Write data in the buffer is written to tape, the EOM bit is set, and the Sense Key is set to No Sense. The residue count consists of blocks requested by the Write command but not yet sent to the buffer.

Recovered Data Errors

If a data error is detected and recovered, the command terminates successfully. If the Post Error bit is one, a Recovered Error Sense Key is returned. If the Post Error bit is zero, the Sense Key is suppressed.

Unrecovered Data Errors

A Medium Error Sense Key is returned for any non-recoverable Write error. A Write command can be reissued after a non-recoverable Write error.

Write File Mark (10h)

The Write File Mark command completes any Write or Copy command in process or writes zero or more file marks starting at the current logical tape position.

The drive rejects the Write File Mark command if the tape is write-protected or if the logical tape position is at EOT and the End Of Medium and Valid bits are set to one.

When zero file marks are specified and the drive is in the buffered mode, the command forces any buffered data to be written, which is known as synchronization. The logical tape position after completing the operation is after the last data block written.

If there is write data in the buffer when this command is received, the drive is synchronized by writing all blocks to tape before executing the Write File Mark command. The drive does not return a Good status message for this command until all buffered data blocks and file marks are correctly written.

The contents of the Write File Mark CDB are in Table 7-42.

Byte	Bit							
	7	6	5	4	3	2	1	0
00	0	0	0	1	1	0	1	0
01	Logical Unit Number			0	0	0	0	Immediate
02	Transfer Length (MSB)							
03	Transfer Length							
04	Transfer Length (LSB)							
05	0	0	0	0	0	0	Flag	Link

Table 7-42. Write File Mark Command

If set to one, the Immediate bit causes status to be returned immediately. If set to zero, status is returned after the command is executed.

The Transfer Length specifies the number of file marks to be written to tape.

COMMON ERROR PROCESSING

Common error processing for all commands is explained in the following sections.

Command Descriptor Block Error

If the command descriptor block is not the correct length or has any illegal parameters, the command is rejected. If the Parameters list (if any) is not the correct length or has any illegal parameters, the command is rejected.

Parity Error

If parity is enabled and a parity error is detected, the drive changes the phase to Message In, sends the initiator a Restore Pointers message to reset the data pointer to the first byte, then changes the phase to Data Out to receive the data again. If a parity error continues after one retry, the command is rejected.

Data Transmission Error

If an Initiator Detected Error message is received while transmitting a data block, the drive retransmits the data block by changing the phase to Message In and sends the initiator a Restore Pointers message to reset the data pointer. If an Initiator Detected Error message is received again, the command is rejected.

COPY ERROR PROCESSING

End of Data Error

If 25 feet of tape is read without encountering data, a Blank Check Sense Key results.

Read and Write Errors

When executing a Copy command, the drive is either the source device or the destination device. Thus, Read or Write command errors may occur, with Read or Write command error processing occurring.

ERASE ERROR PROCESSING

Completion Error

If an error occurs that prevents the Erase operation from completing, the command terminates with a Hardware Error Sense Key.

Synchronization Error

During a Synchronization any of the Write command errors may occur. Thus, Write command error processing may result.

READ ERROR PROCESSING

Information Content For Errors

For all errors, unless otherwise stated, the Information Bytes of the Extended Sense (Table 7-27) are set in the Variable Block Mode equal to the difference between the requested Transfer Length and the actual block length; in the Fixed Block Mode they are set equal to the difference between the requested Transfer Length and the actual number of blocks read, not including the block in error.

End of Data Error

If 25 feet of tape is read without encountering data, a Blank Check Sense Key results.

Block Length Error

In the Variable Block Mode if the actual block length exceeds the specified Transfer Length, no more than the Transfer Length is transmitted to the initiator. If the actual block length is less than the specified Transfer Length, no more than the actual block length is transferred. The Valid and Incorrect Length Indicator bits set to one and the command terminates. At termination the logical position is after the block with the incorrect length.

In the Variable Block Mode if the Transfer Length exceeds the maximum allowable value specified in the Read Block Limits data, the command is rejected with an Illegal Request Sense key.

In the Fixed Block Mode if the actual block length encountered is different than the specified length, no additional blocks are transferred. The Valid and Incorrect Length Indicator bits set to one and the command terminates. At termination, the logical position is after the block with the incorrect length.

In the Fixed Block Mode if the actual number of blocks available is less than the specified transfer length, no more than the actual number of blocks is transferred. A File Mark Error, an End of Data Error, or an End of Medium Error is reported.

Buffer Parity Error

If an unrecoverable buffer parity error occurs, a Hardware Error Sense Key results.

End-of-Medium Error

If the RDEW (Report Early-Warning End-of-Medium on Read) bit is set to one and the end of medium (i.e., EOT reflector) is encountered, the command terminates with the End Of Medium bit set to one.

If the physical end of medium (i.e., 18 feet past EOT), is encountered, the command terminates with the End Of Medium bit set to one and a Medium Error Sense Key.

File Mark Error

If a file mark is read, the Valid and File Mark bits set to one and the command terminates. At termination the logical position is after the file mark.

Recovered Data Error

If the drive detects and recovers one or more data errors, the command terminates successfully. If the Post Error bit is set to one, a Recovered Error Sense Key results; if set to zero, recovered error reporting is suppressed.

Unrecovered Data Error

If an unrecovered error occurs, the drive backspaces and attempts to re-read the data up to eight times. If the data cannot be recovered, the command terminates with a Check Status and a Medium Error Sense Key.

READ REVERSE ERROR PROCESSING

Information Content For Errors

For all errors, unless otherwise stated, the Information Bytes of the Extended Sense (Table 7-27) are set in the Variable Block Mode equal to the difference between the requested Transfer Length and the actual block length; in the Fixed Block Mode they are set equal to the difference between the requested Transfer Length and the actual number of blocks read, not including the block in error.

Block Length Error

In the Variable Block Mode if the actual block length exceeds the specified Transfer Length, no more than the Transfer Length is transmitted to the initiator. If the actual block length is less than the specified Transfer Length, no more than the actual block length is transferred. The Valid and Incorrect Length Indicator bits set to one and the command terminates. At termination the logical position is before the block with the incorrect length.

In the Variable Block Mode if the Transfer Length exceeds the maximum allowable value specified in the Read Block Limits data, the command is rejected with an Illegal Request Sense Key.

In the Fixed Block Mode if the actual block length encountered is different than the specified Transfer Length, no additional blocks are transferred. The Valid and Incorrect Length Indicator bits set to one and the command terminates. At termination, the logical position is before the block with the incorrect length.

In the Fixed Block Mode if the actual number of blocks available is less than the specified Transfer Length, no more than the actual number of blocks is transferred. A File Mark Error or an End Of Medium Error is reported.

Beginning Of Tape Error

If BOT is encountered, the command terminates with the Valid and End Of Medium bits set to one. At termination the logical position is at BOT.

Buffer Parity Error

If an unrecoverable buffer parity error occurs, a Hardware Error Sense Key results.

File Mark Error

If a file mark is read, the Valid and File Mark bits set to one and the command terminates. At termination the logical position is before the file mark.

Recovered Data Error

If the drive detects and recovers one or more data errors, the command terminates successfully. If the Post Error bit is set to one, a Recovered Error Sense Key results; if set to zero, recovered error reporting is suppressed.

Unrecovered Data Error

If an unrecovered error occurs, the drive spaces forward and attempts to re-read the data up to eight times. If the data cannot be recovered, the command terminates with a Check Status and a Medium Error Sense Key.

SPACE ERROR PROCESSING

Information Content For Errors

For all errors, unless otherwise stated, the Information Bytes of the Extended Sense (Table 7-27) are set equal to the difference between the requested count and the actual number of blocks or file marks spaced over.

End of Data Error

If 25 feet of tape is read without encountering data, a Blank Check Sense Key results.

End Of Medium Error

If the RDEW (Report Early-Warning End-of-Medium on Read) bit is set to one and the end of medium (i.e., EOT reflector) is encountered, the command terminates with the End Of Medium and Valid bits set to one. At termination the logical position is after the last data block or file mark read.

If the physical end of medium (i.e., 18 feet past EOT), is encountered, the command terminates with the End Of Medium bit set to one and a Medium Error Sense Key.

File Mark Error

If a file mark is encountered, the Valid and File Mark bits set to one and the command terminates. The Information Bytes of the Extended Sense are set equal to the difference between the requested count and the actual number of blocks spaced over, not including the file mark. At termination the logical position is on the EOT-side of the file mark if the tape movement was forward or on the BOT-side of the file mark if the tape movement was in reverse.

Unrecovered Data Error

Data and block length errors are not reported during a Space command.

Beginning of Tape Error

If BOT is encountered while spacing in reverse, the command terminates with the Valid and End Of Medium bits set to one. At termination the logical position is at BOT.

Synchronization Error

During a synchronization any of the Write command errors may occur. Thus, Write command error processing may result.

WRITE ERROR PROCESSING

For all errors, unless otherwise stated, the Information Bytes of the Extended Sense (Table 7-27) are set in the Buffered Variable Block Mode equal to the number of bytes and file marks not written (i.e., the number of bytes not transferred from the initiator plus the number of bytes and file marks remaining in the buffer). The value in the Information Bytes may exceed the Transfer Length.

In the Unbuffered Variable Block Mode the Information Bytes are set equal to the requested Transfer Length.

In the Buffered Fixed Block Mode the Information Bytes are set equal to the number of blocks and file marks not written (i.e., the number of blocks not transferred from the initiator plus the number of blocks and file marks remaining in the buffer). The value in the Information Bytes may exceed the Transfer Length.

In the Unbuffered Fixed Block Mode the Information Bytes are set equal to the difference between the requested Transfer Length and the actual number of blocks written.

Block Length Error

In the Variable Block Mode if the actual block length exceeds the Maximum Block Length specified in the Read Block Limits data, the command is rejected with an Illegal Request Sense Key.

End Of Medium Error

When the Early-Warning End-of-Medium (i.e., EOT reflector) is detected, all data then in the buffer is written to the medium. The End Of Medium bit sets to one with a No Sense Sense Key.

If the physical end of medium (i.e., 18 feet past EOT) is encountered, the command terminates with the Valid and End Of Medium bits set to one and a Volume Overflow Sense Key. The value in the Information Bytes equals the number of blocks remaining in the buffer plus those not yet transferred from the initiator.

Recovered Data Error

If the drive detects and recovers one or more data errors, the command terminates successfully. If the Post Error bit is set to one, a Recovered Error Sense Key results; if set to zero, recovered error reporting is suppressed.

Unrecovered Data Error

If an unrecoverable error occurs, a Medium Error Sense Key results. Before reporting this error, the drive backspaces, erases a section of tape, and attempts to rewrite the data eight times.

WRITE FILE MARK ERROR PROCESSING

End Of Medium Error

When the Early-Warning End-of-Medium (i.e., EOT reflector) is detected, the command terminates with the Valid and End Of Medium bits set to one. At termination the logical position is after the last file mark written.

When physical end of medium (i.e., 18 feet past EOT) is detected, the command terminates with the Valid and End Of Medium bits set to one and a Volume Overflow Sense Key.

In the Buffered Variable Block Mode the Information Bytes of the Extended Sense (Table 7-27) are set equal to the total number of unwritten bytes and file marks (i.e., the number of file marks not transferred from the initiator plus the number of bytes and file marks remaining in the buffer).

In the Buffered Fixed Block Mode the Information Bytes are set equal to the total number of unwritten blocks and file marks (i.e., the number of file marks not transferred from the initiator plus the number of blocks and file marks remaining in the buffer).

In the Unbuffered mode the Information Bytes are set equal to the difference between the requested Transfer Length and the actual number of file marks written.

Recovered File Mark Error

If the drive detects and recovers one or more file mark errors, the command terminates successfully. If the Post Error bit is set to one, a Recovered Error Sense Key results; if set to zero, recovered error reporting is suppressed.

Synchronization Error

During a synchronization any of the Write command errors may occur. Thus, Write command error processing may result.

VERIFY ERROR PROCESSING

Information Content For Errors

For all errors, unless otherwise stated, the Information Bytes of the Extended Sense (Table 7-27) are set in the Variable Block Mode equal to the difference between the requested Verification Length and the actual block length; in the Fixed Block Mode they are set equal to the difference between the requested Verification Length and the actual number of blocks verified, not including the block in error.

Block Length Error

In the Variable Block Mode if the actual block length exceeds the specified Verification Length, no more than the Verification Length is verified. If the actual block length is less than the specified Verification Length, no more than the actual block length is verified. The Valid and Incorrect Length Indicator bits set to one and the command terminates. At termination the logical position is after the block with the incorrect length.

In the Variable Block Mode if the Verification Length exceeds the maximum allowable value specified in the Read Block Limits data, the command is rejected with an Illegal Request Sense key.

In the Fixed Block Mode if an actual block length is encountered that is different than the specified length, no additional blocks are verified. The Valid and Incorrect Length Indicator bits set to one and the command terminates. At termination the logical position is after the block with the incorrect length.

In the Fixed Block Mode if the actual number of blocks available is less than the specified verification length, no more than the actual number of blocks is verified. A File Mark Error, an End Of Data Error, or an End Of Medium Error is reported.

End Of Data Error

If 25 feet of blank tape is encountered, the command terminates with the Valid bit set to one and a Blank Check Sense Key. In the Variable Block Mode the Incorrect Length Indicator bit also sets to one. At termination the logical position is after the last data block verified.

End Of Medium Error

If the RDEW (Report Early-Warning End-of-Medium on Read) bit is set to one and the end of medium (i.e., EOT reflector) is encountered, the command terminates with the End Of Medium bit set to one. At termination the logical position is after the last data block verified.

If the physical end of medium (i.e., 18 feet past EOT) is encountered, the command terminates with the End Of Medium bit set to one and a Medium Error Sense Key.

File Mark Error

If a file mark is read, the Valid and File Mark bits set to one and the command terminates. At termination the logical position is after the file mark.

Recovered Data Error

If the drive detects and recovers one or more data errors, the command terminates successfully. If the Post Error bit is set to one, a Recovered Error Sense Key results; if set to zero, recovered error reporting is suppressed.

Unrecovered Data Error

If an unrecovered error occurs, the drive backspaces and attempts to re-read the data up to eight times. If the data cannot be recovered, the command terminates with a Check Status and a Medium Error Sense Key. At termination the logical position is after the data block with the error.

Chapter 8 Specifications

PERFORMANCE

Data Capacity

	1600 bpi	3200 bpi
2400-foot tape	46 megabytes	92 megabytes

Head-to-Tape Data Transfer Rate

160 kilobytes per second

Interface Burst Rate

1.5 Megabytes per second maximum, asynchronous

Recording Speeds

25 and 100 inches per second at 1600 bits per inch
50 inches per second at 3200 bits per inch

Rewind Speed

175 inches per second

Operating Times

Operation	25 ips	50 ips	100 ips
Data Access	40 ms	120 ms	260 ms
Reposition	120 ms	360 ms	780 ms
Write Reinstruct	10.0 to 11.0 ms	5.0 to 6.0 ms	2.0 to 3.5 ms
Read Forward Reinstruct	16.0 to 18.0 ms	4.0 to 5.0 ms	3.0 to 4.0 ms

Table 8-1. Operating Times

Recording Format

Nine-track phase encode per ANSI X3-39-1973 and ANSI X3.157-1987.

INTERFACE

Small Computer Systems Interface per ANSI X3.131-1986.

MECHANICAL SPECIFICATIONS

Mounting

Rack mounting in standard 19-inch EIA equipment rack or table-top enclosure.

Dimensions

	Rack-Mount	Table-Top
Height	8.75 inches	10.59 inches
Width	19.0 inches	19.88 inches
Depth	24.5 inches	26.94 inches

Weight

Rack-mount	80 pounds
Table-top	97 pounds

POWER

Nominal Input Voltages

100/120 Vac
208/220/240 Vac

Operating Input Voltages

85 to 132 Vac
187 to 264 Vac

Power Consumption

220 watts maximum

ENVIRONMENTAL SPECIFICATIONS

Acoustic Noise Emission

60 dBa maximum measured from one meter

Heat Dissipation

750 BTUs per hour maximum

Operating Conditions

Dry Bulb Temperature	10 to 40 degrees Celsius
Wet Bulb Temperature	26 degrees Celsius maximum
Relative Humidity	20 to 85 percent non-condensing
Altitude	10,000 feet maximum

Vibration

Frequency	5 to 500 Hz
Amplitude	0.3 gravity

Shock

Peak Acceleration	1.0 gravity
Duration	20 milliseconds

INTERFACE CABLE

See Chapter 2, "Interface Cable."

REGULATORY REQUIREMENTS

Safety

UL 478, CSA C22.2 #220, IEC 380 and 950

Electromagnetic Emissions

FCC Part 15, Subpart J, Class A
VDE 871 and 875, Class B

TAPE

0.5 inch wide, 1.5 mil thick magnetic tape per ANSI Standard X3.40-1976 on 7.0, 8.5, and 10.5 inch reels.

8 7 6 5 4 3 2 1

REVISION					
LTR	DESCRIPTION	DWN	DATE	APVD	DATE
01	PILOT HCL ERD 50-29-0029	EC	8-24-89	RF	8-24-89



966129-300
REV 01

- ⑤ THESE COMPONENTS ARE NOT USED.
 - ④ THESE COMPONENTS USED ON THE SINGLE-ENDED PWB. ASSY. ONLY
 - ③ THESE COMPONENTS USED ON THE DIFFERENTIAL PWB. ASSY. ONLY
2. ALL CAPACITORS ARE IN MICROFARADS
1. ALL RESISTORS ARE IN OHMS
- NOTES: UNLESS OTHERWISE SPECIFIED

ALL INFORMATION CONTAINED IN OR DISCLOSED BY THIS DOCUMENT IS CONSIDERED CONFIDENTIAL AND PROPRIETARY BY CIPHER DATA PRODUCTS, INC. BY ACCEPTING THIS MATERIAL THE RECIPIENT AGREES THAT THIS MATERIAL AND THE INFORMATION CONTAINED THEREIN IS HELD IN CONFIDENCE AND IN TRUST AND WILL NOT BE USED, REPRODUCED IN WHOLE OR IN PART, NOR ITS CONTENTS REVEALED TO OTHERS, EXCEPT TO MEET THE PURPOSE FOR WHICH IT WAS DELIVERED. IT IS UNDERSTOOD THAT NO RIGHT IS CONVEYED TO REPRODUCE OR HAVE REPRODUCED ANY ITEM HEREIN DISCLOSED WITHOUT EXPRESS PERMISSION FROM CIPHER DATA PRODUCTS, INC.

UNLESS OTHERWISE SPECIFIED DIMENSIONS ARE IN INCHES	APPROVAL	DATE	SAN DIEGO CALIF.	
TOLERANCES ARE DECIMALS	CHK: <i>[Signature]</i>	DATE: 8/24/89	TITLE: SCHEM - SCSI TAPE CONTR.	
.X ±	DES MGR: <i>[Signature]</i>	CODE IDENT: 32274	SIZE: D	DWG NO: 966129-300
.XX ±	ISSUED: <i>[Signature]</i> 8-24-89	SCALE: ~	MOD: F880ES	REV: 01
.XXX ±				OF 35
ANGLES ±				
DO NOT SCALE DRAWING				

A 1 2 3 4 5 6 7 8 9 10 11 12 13 14 15 16 17 18 19 20 21 22 23 24

8 7 6 5 4 3 2 1

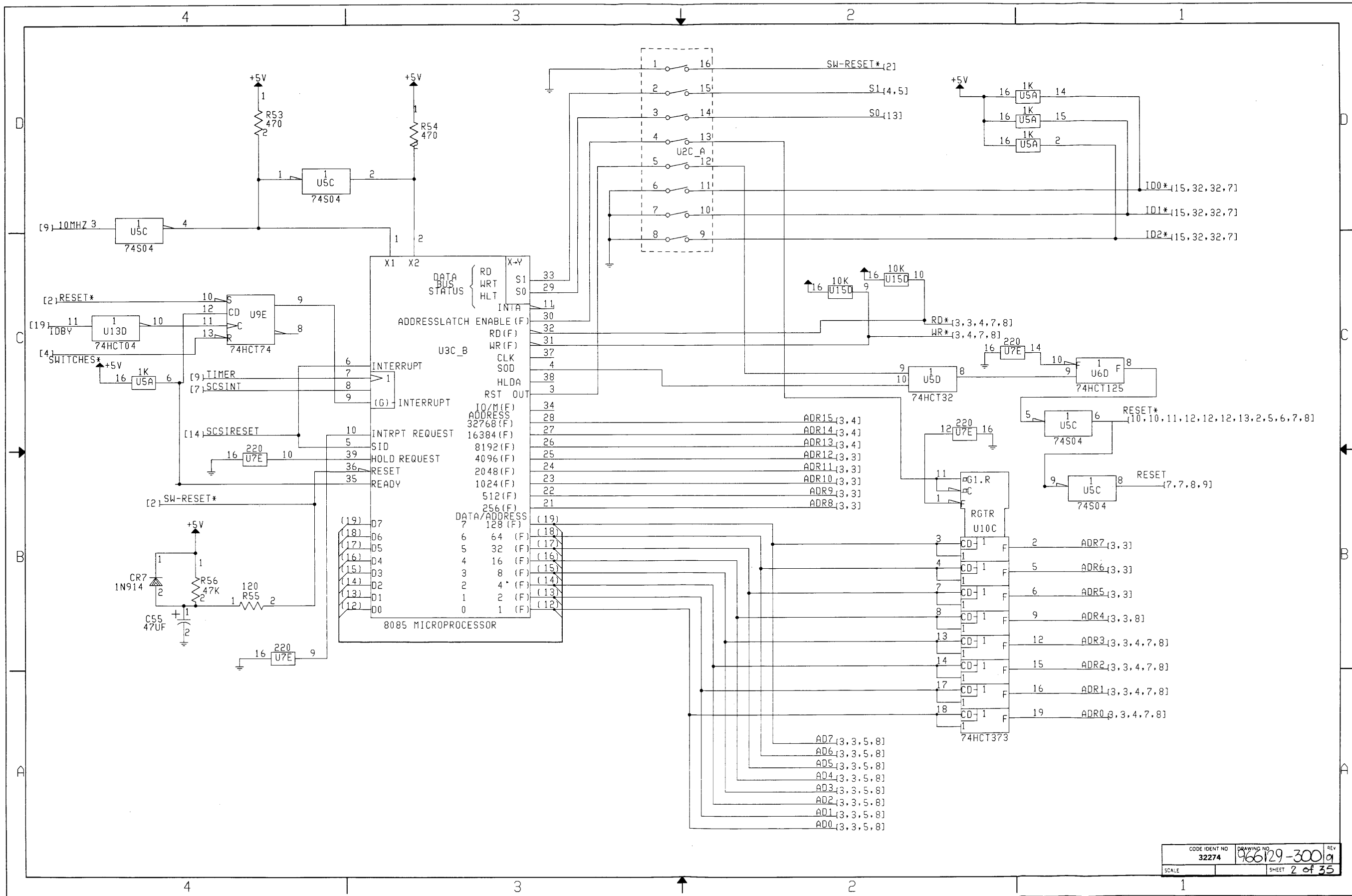

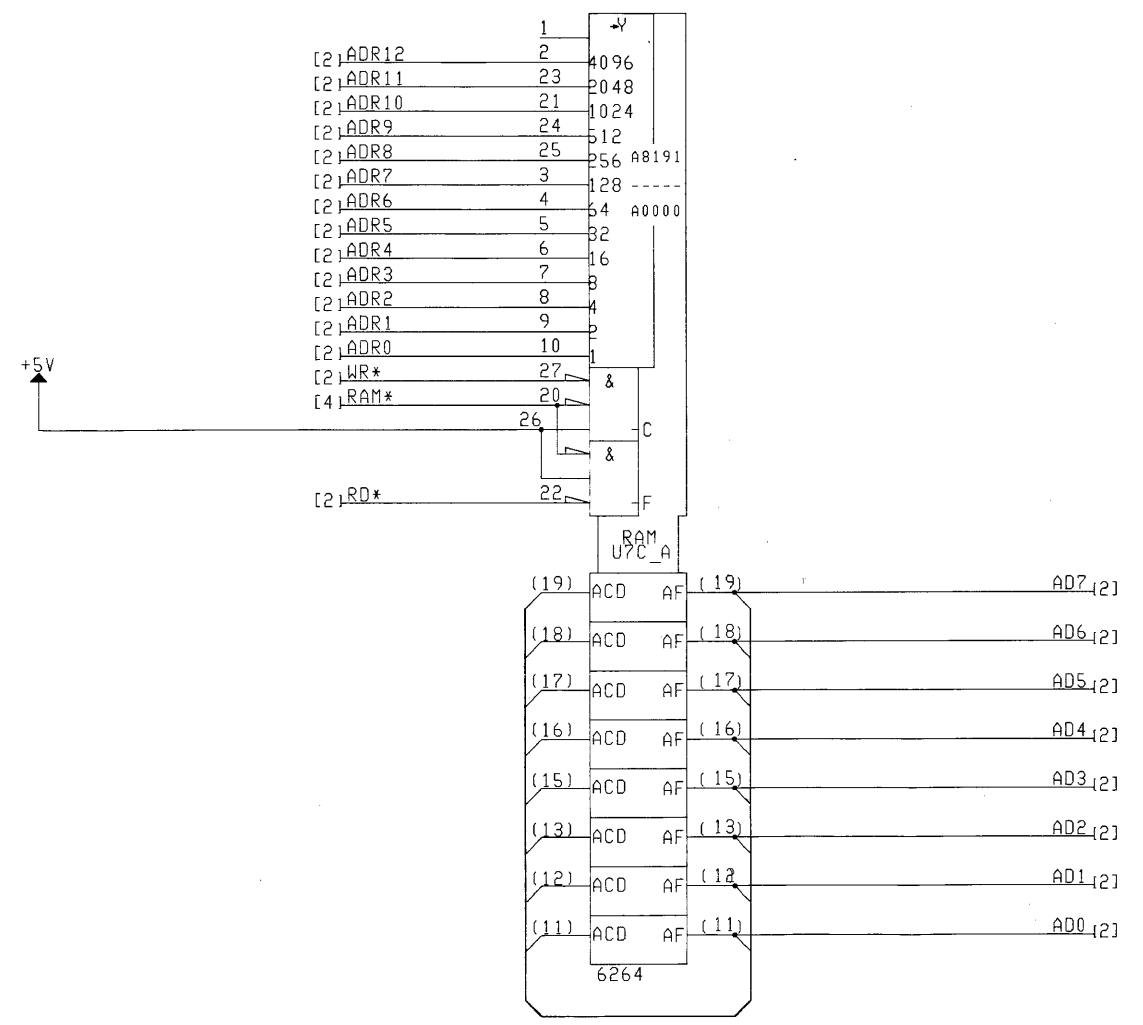
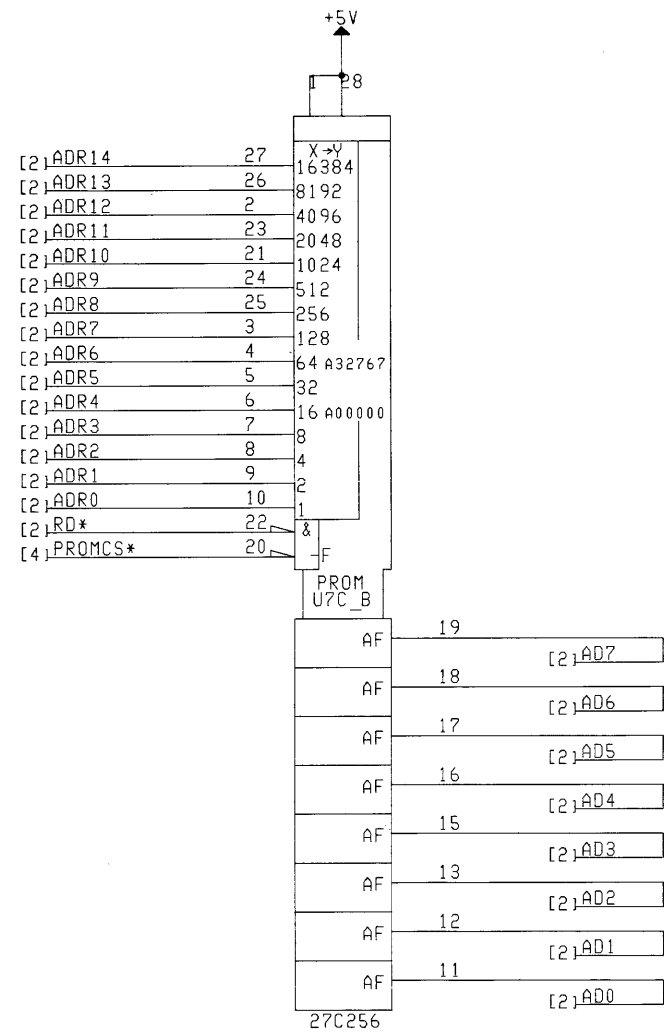

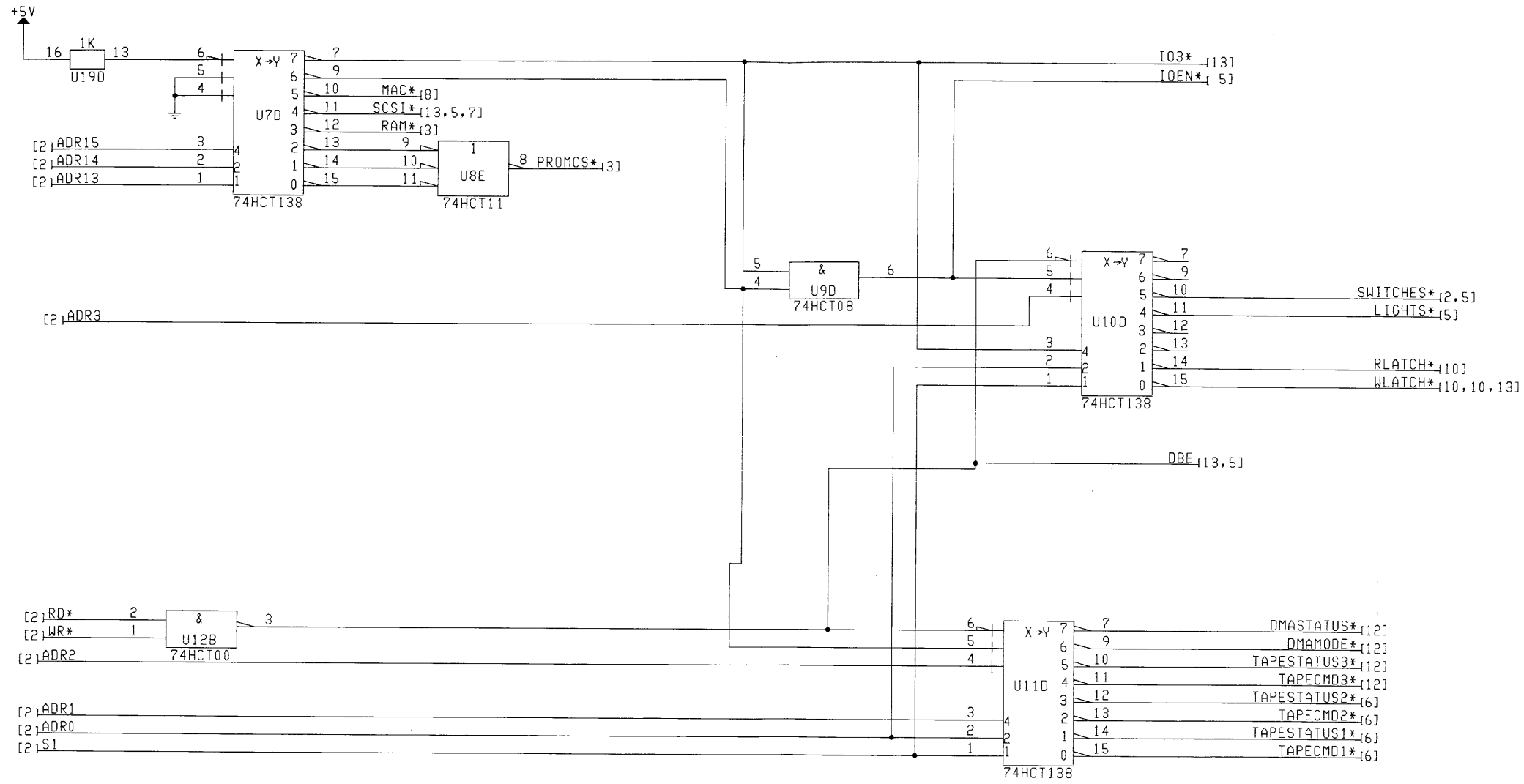

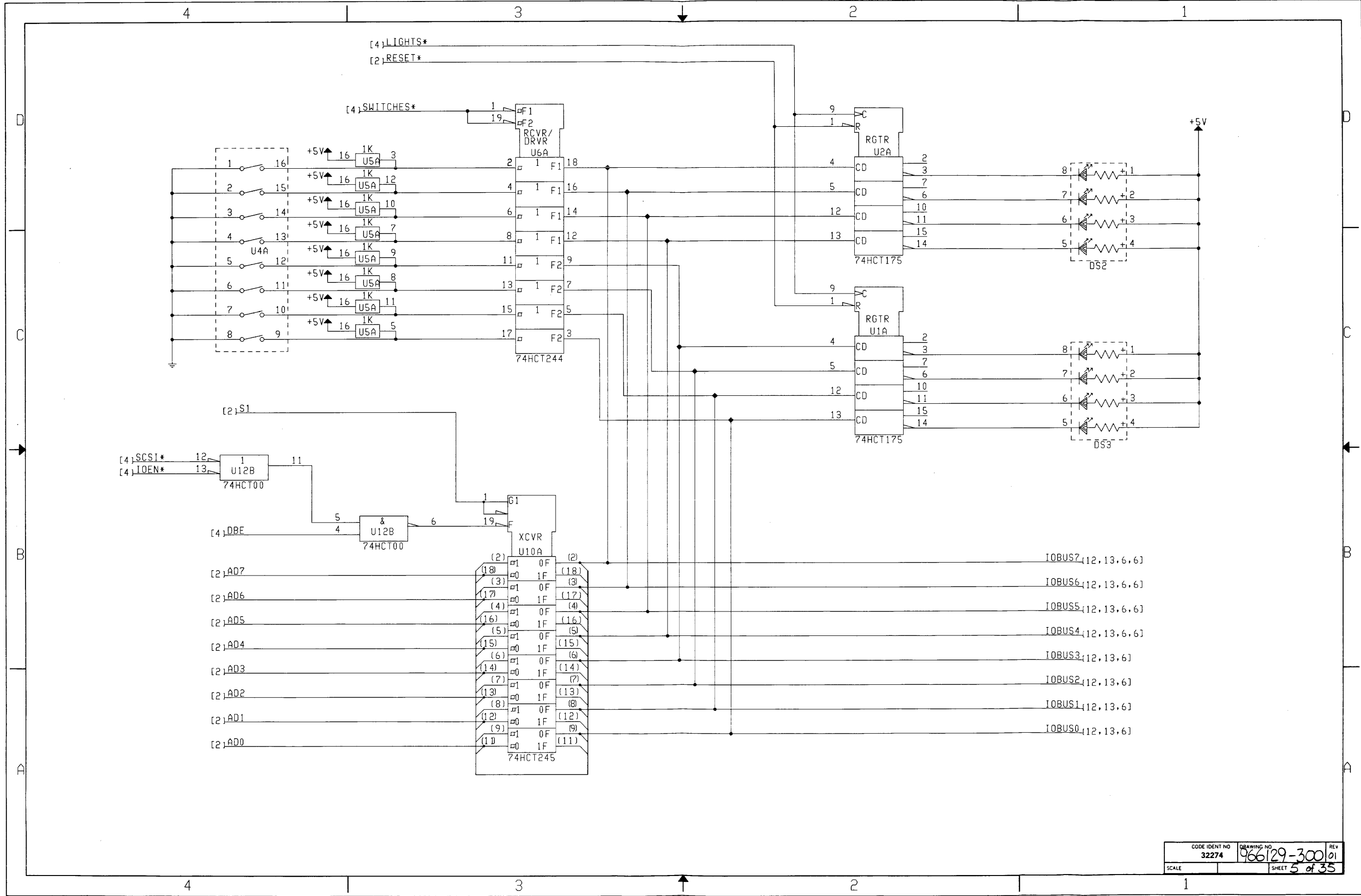

[4]SCS1*
[4]IOEN*

[4]DBE

[2]AD7

[2]AD6

[2]AD5

[2]AD4

[2]AD3

[2]AD2

[2]AD1

[2]AD0

IOBUS7_(12,13,6,6)

IOBUS6_(12,13,6,6)

IOBUS5_(12,13,6,6)

IOBUS4_(12,13,6,6)

IOBUS3_(12,13,6)

IOBUS2_(12,13,6)

IOBUS1_(12,13,6)

IOBUS0_(12,13,6)

CODE IDENT NO 32274	DRAWING NO 966129-300	REV 01
SCALE	SHEET 5 of 35	

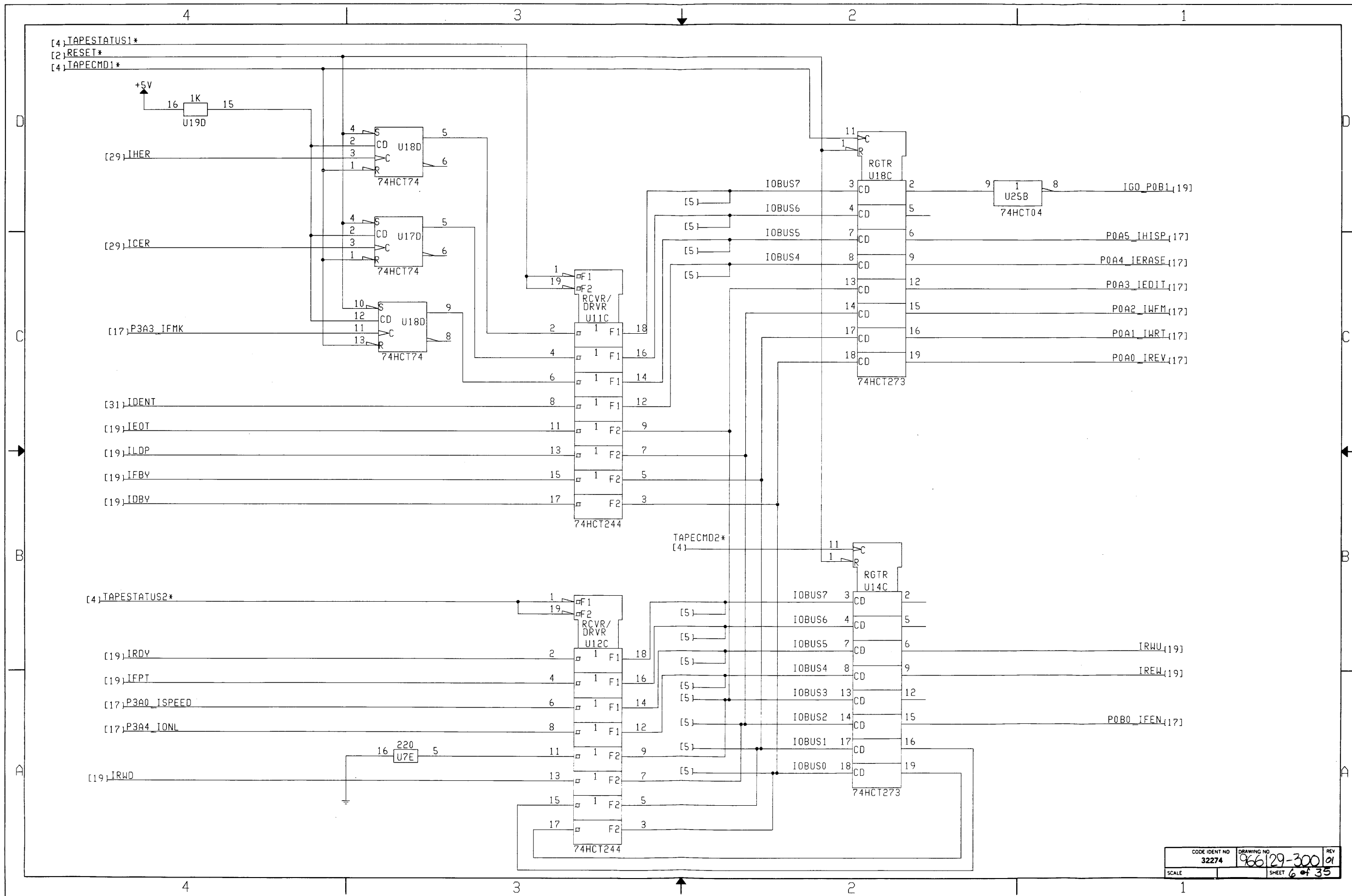

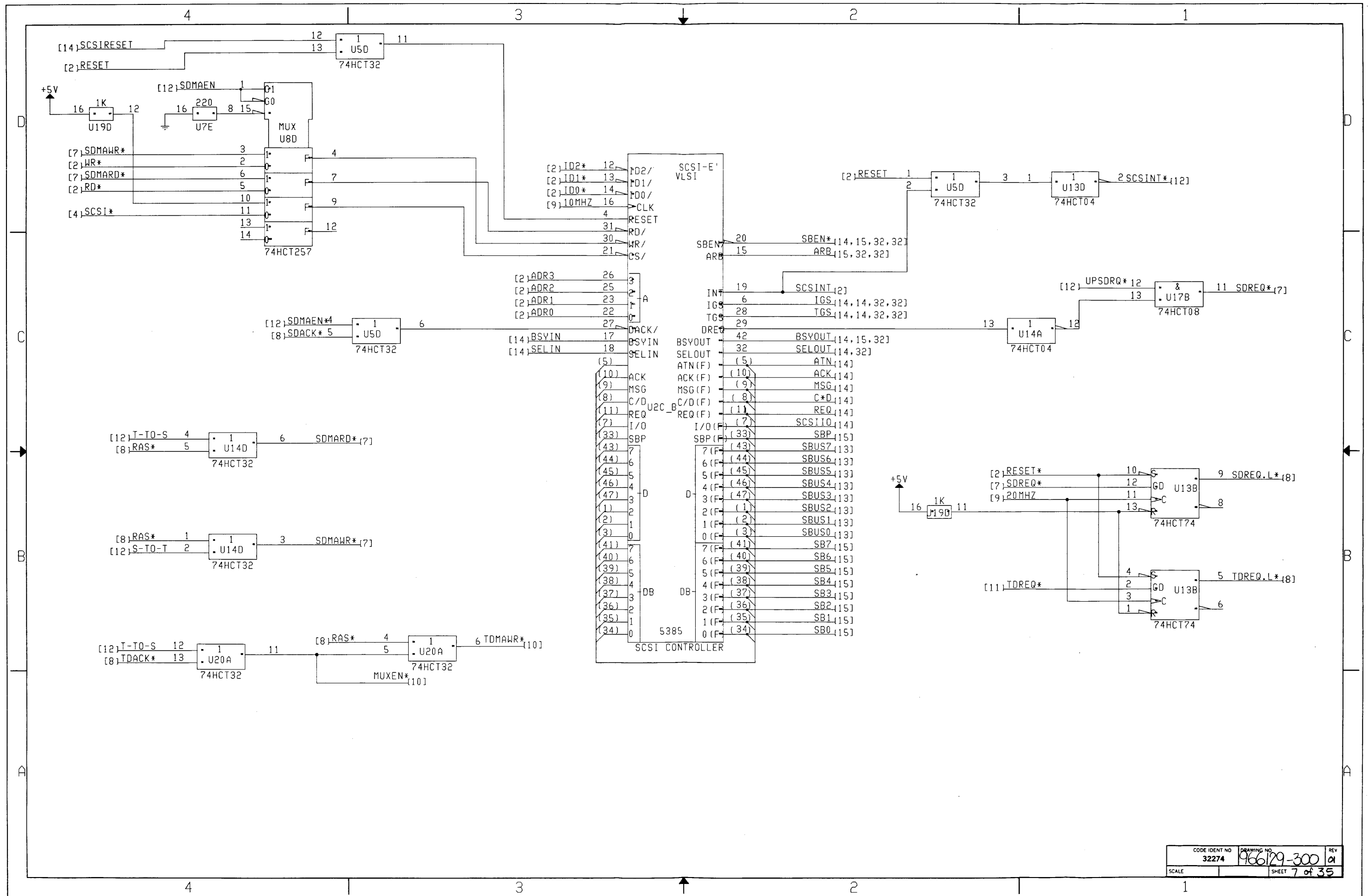

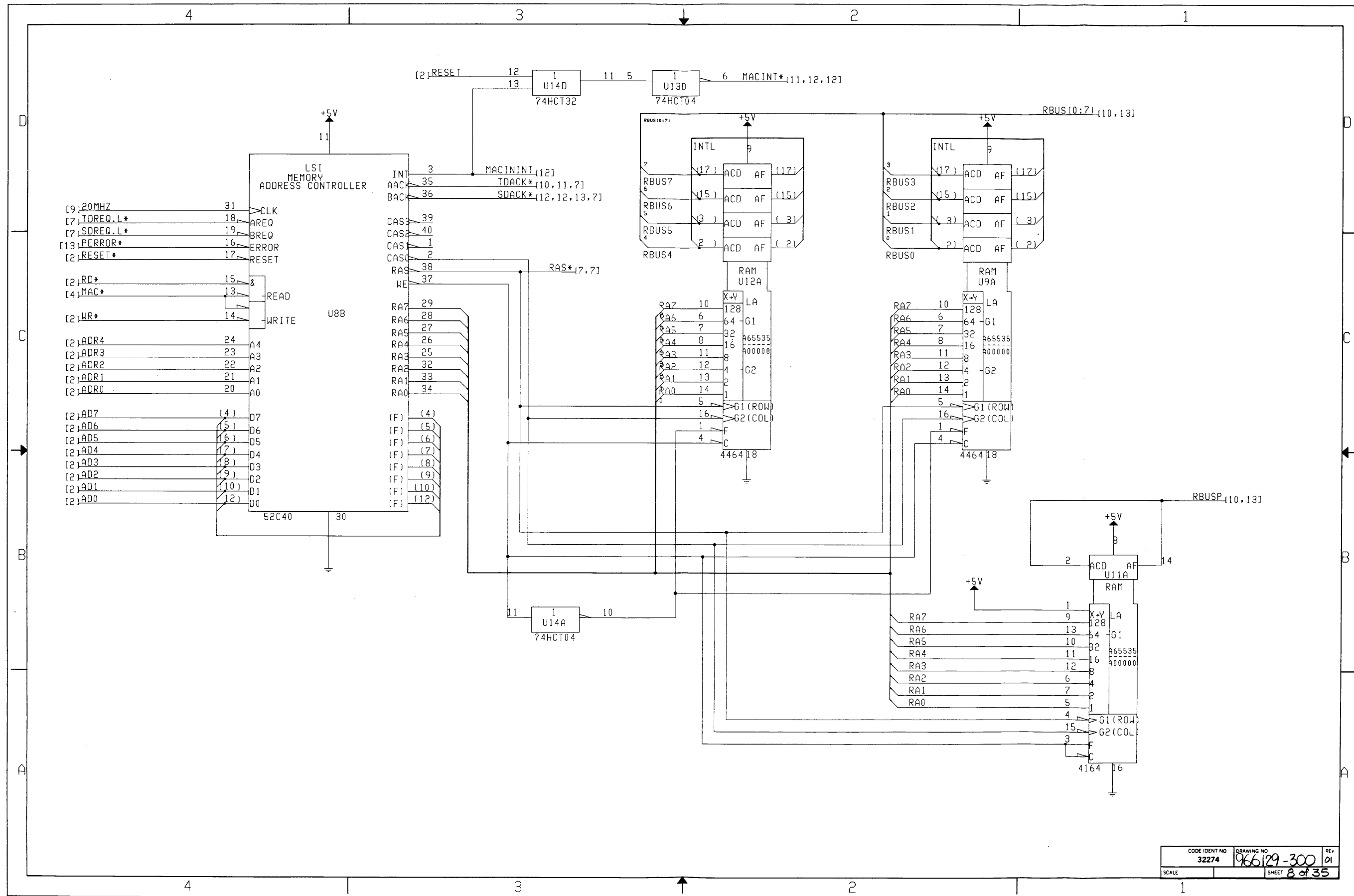

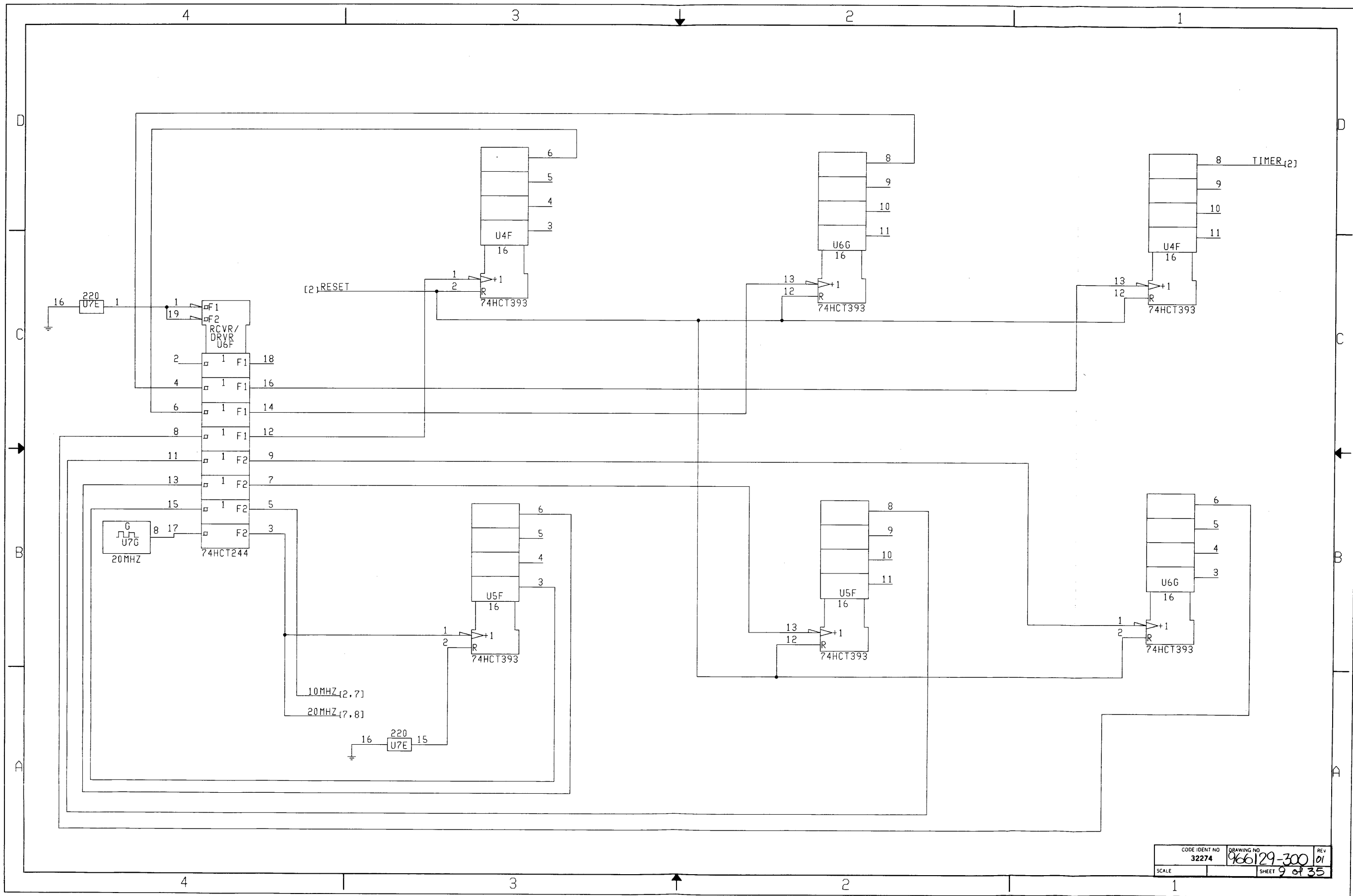

CODE IDENT NO 32274	DRAWING NO 966129-300	REV 01
SCALE	SHEET 9 of 35	

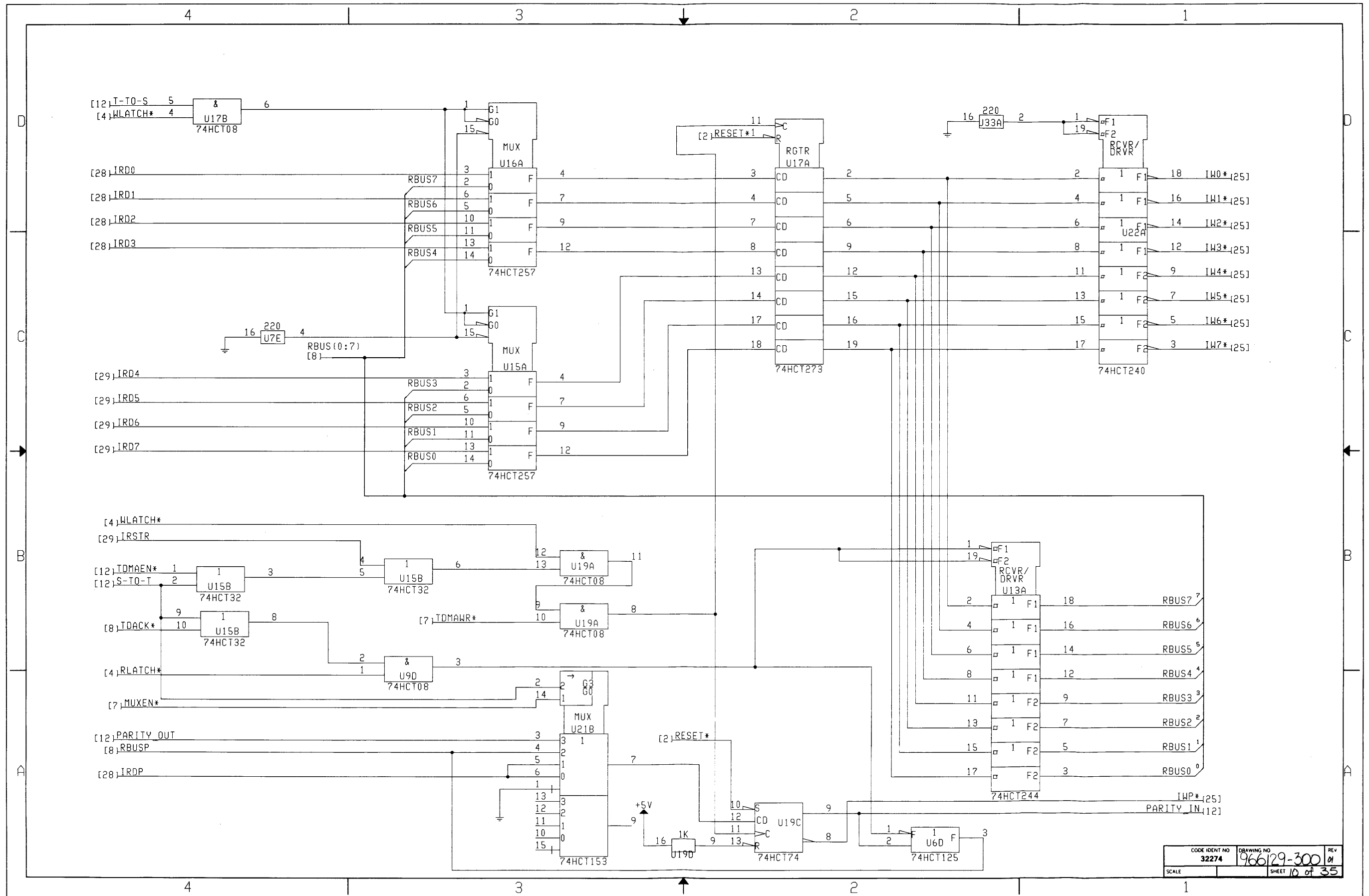

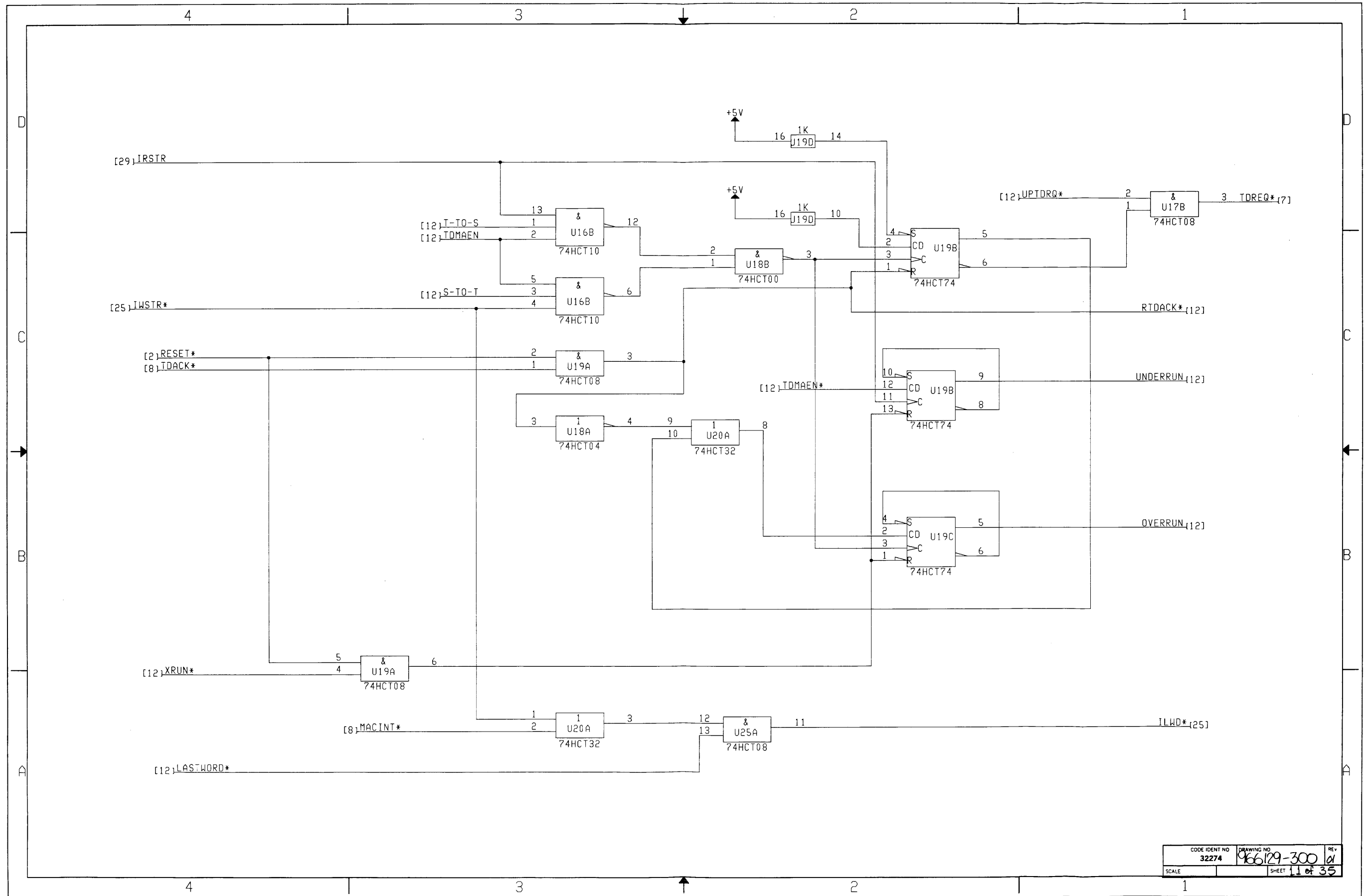

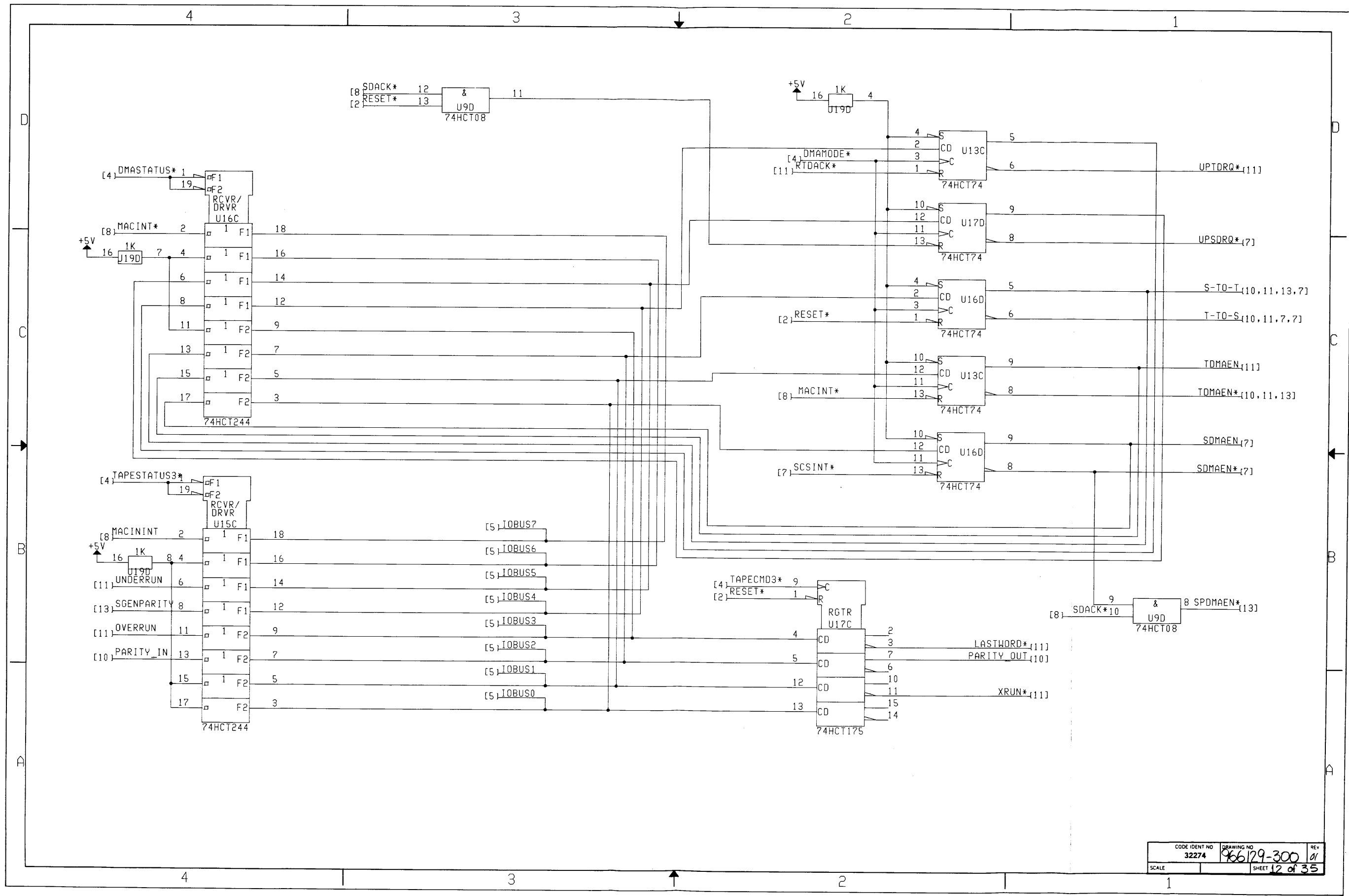

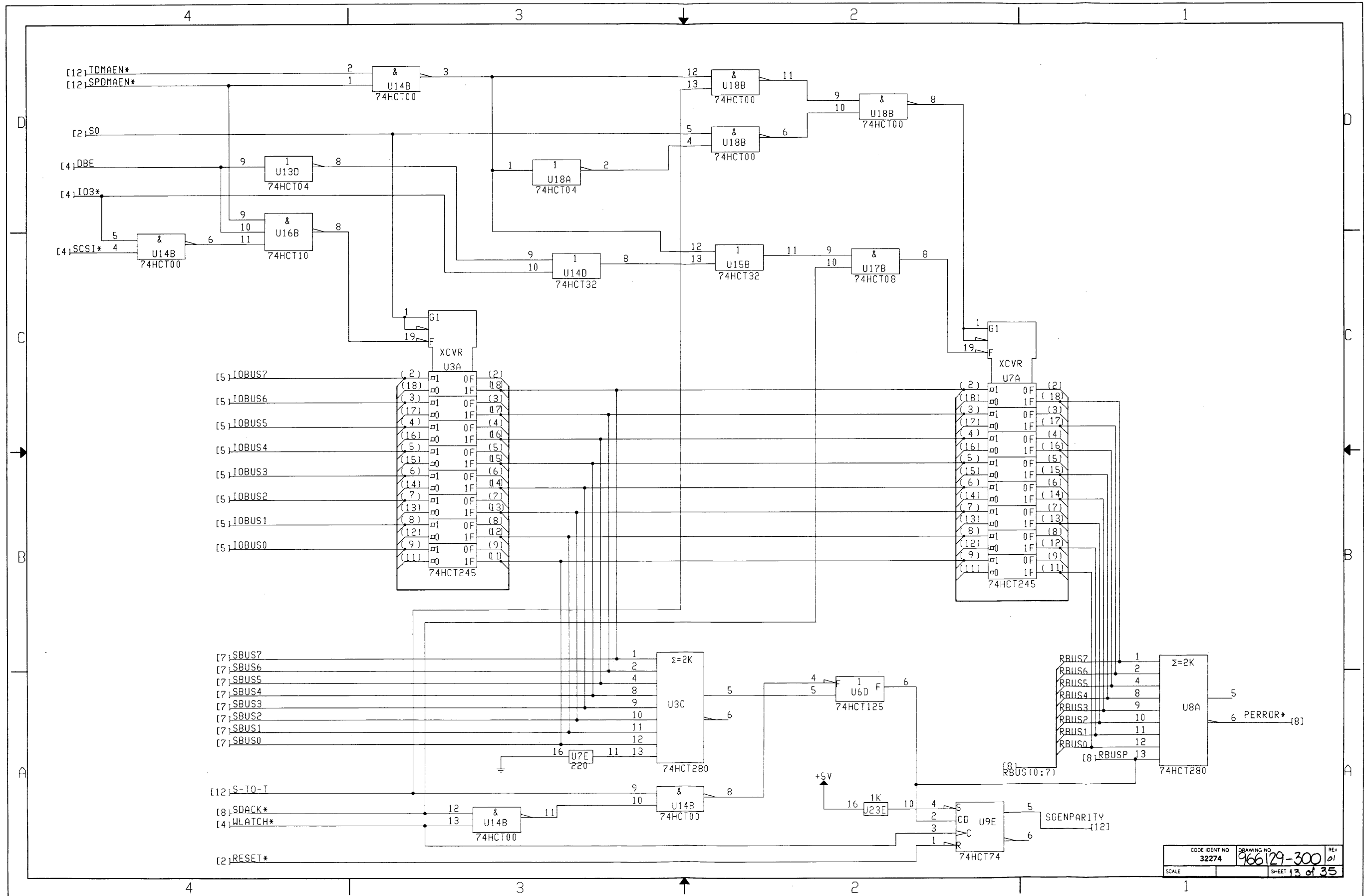

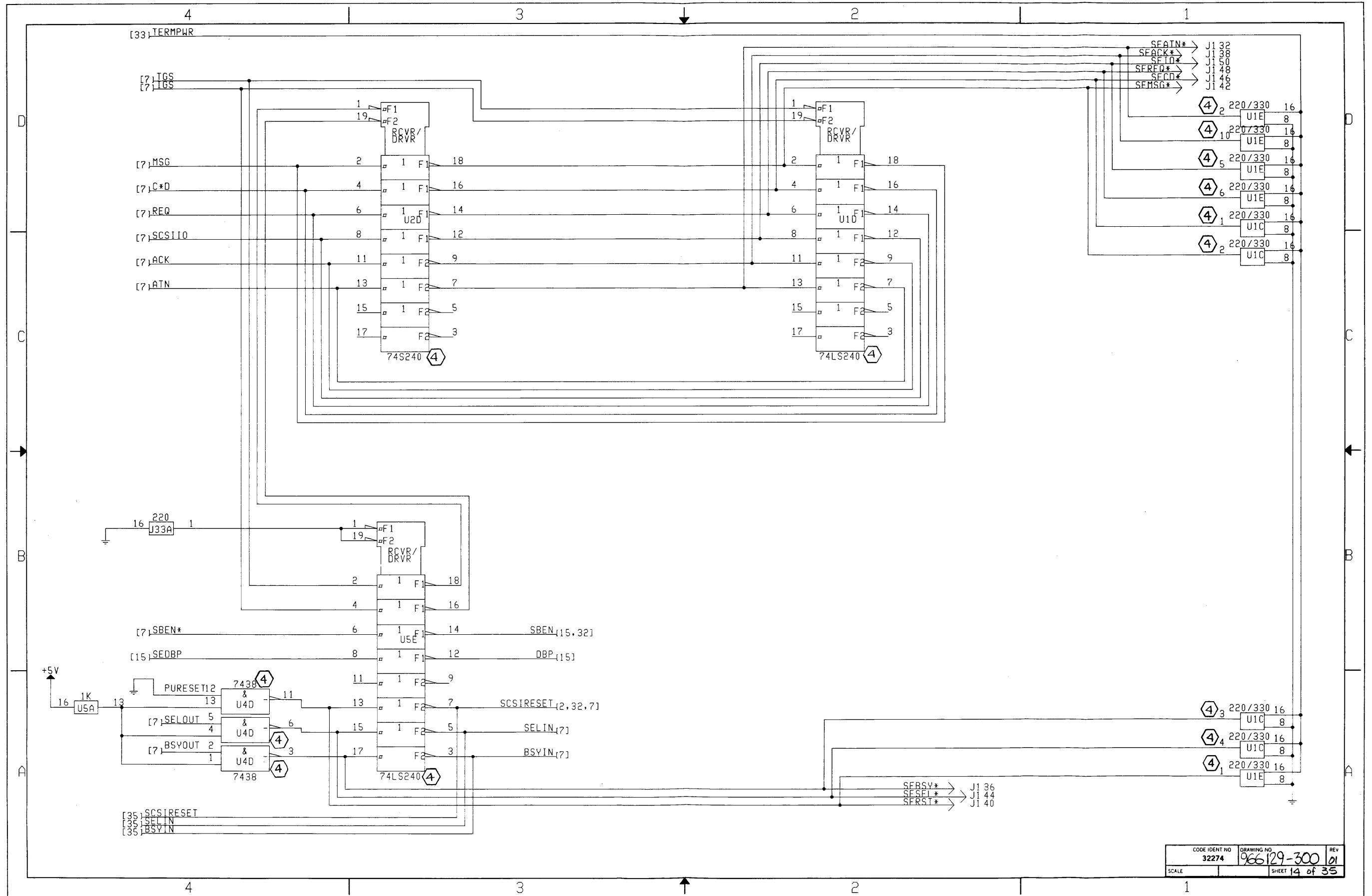

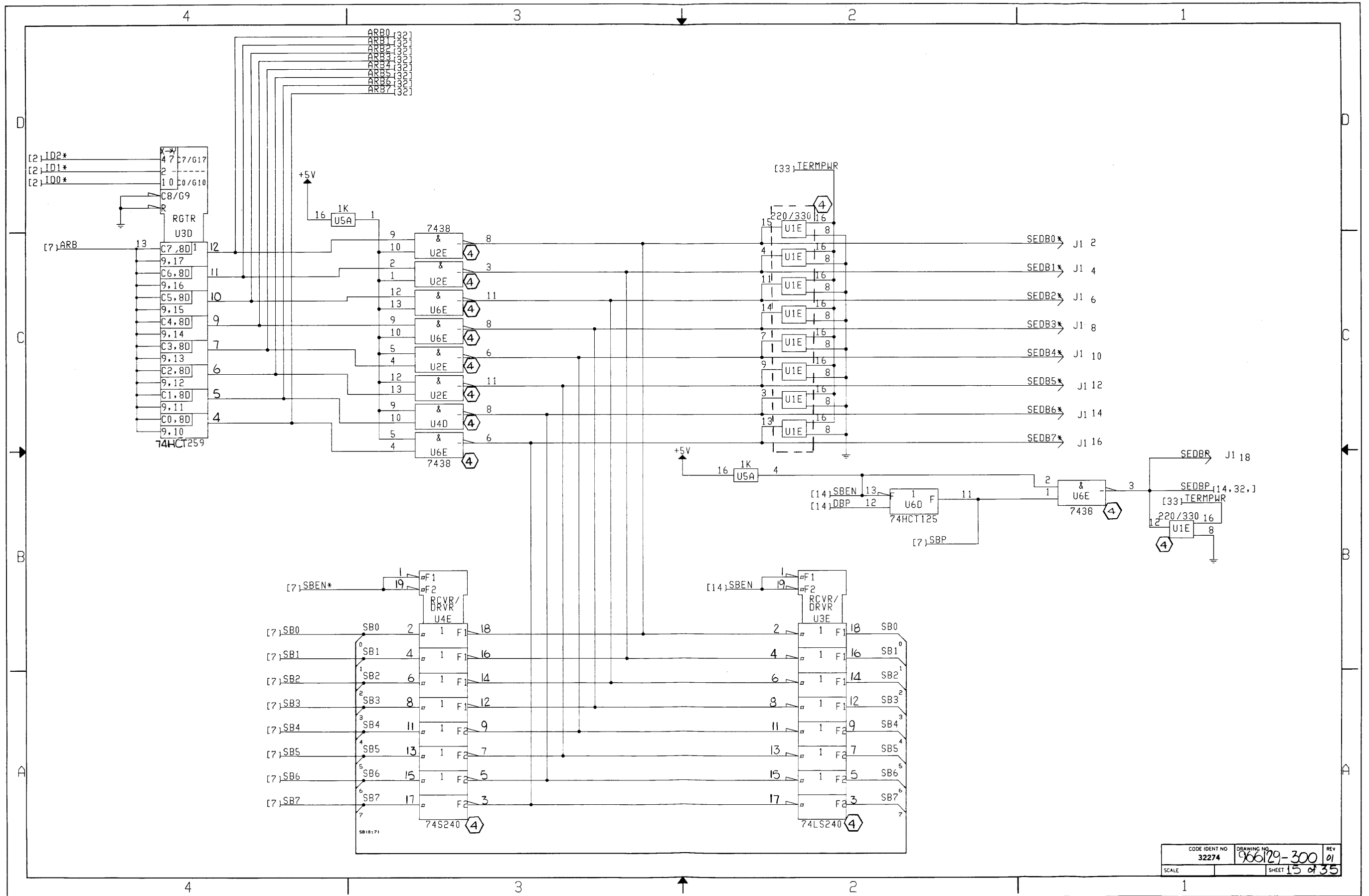

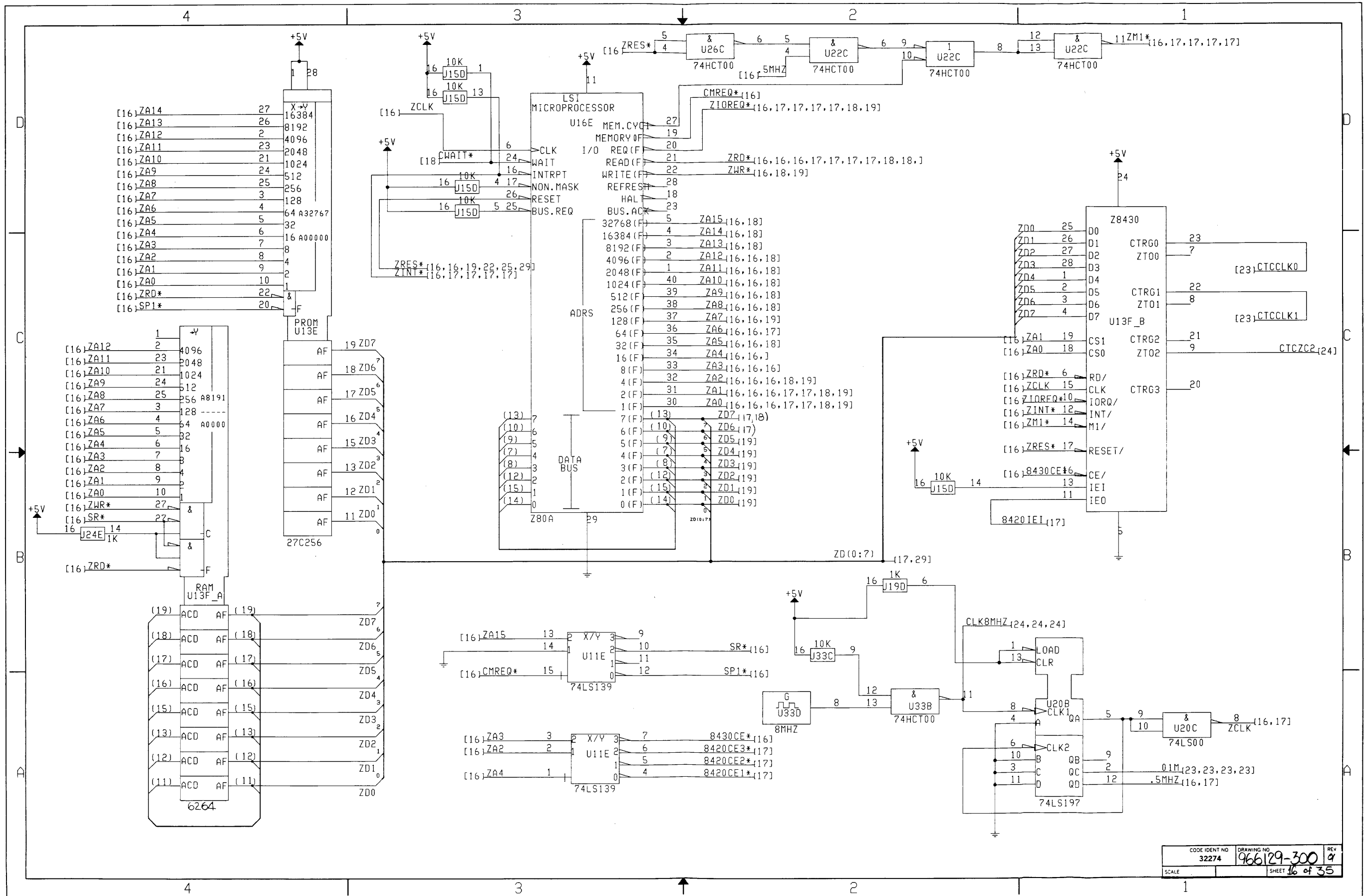

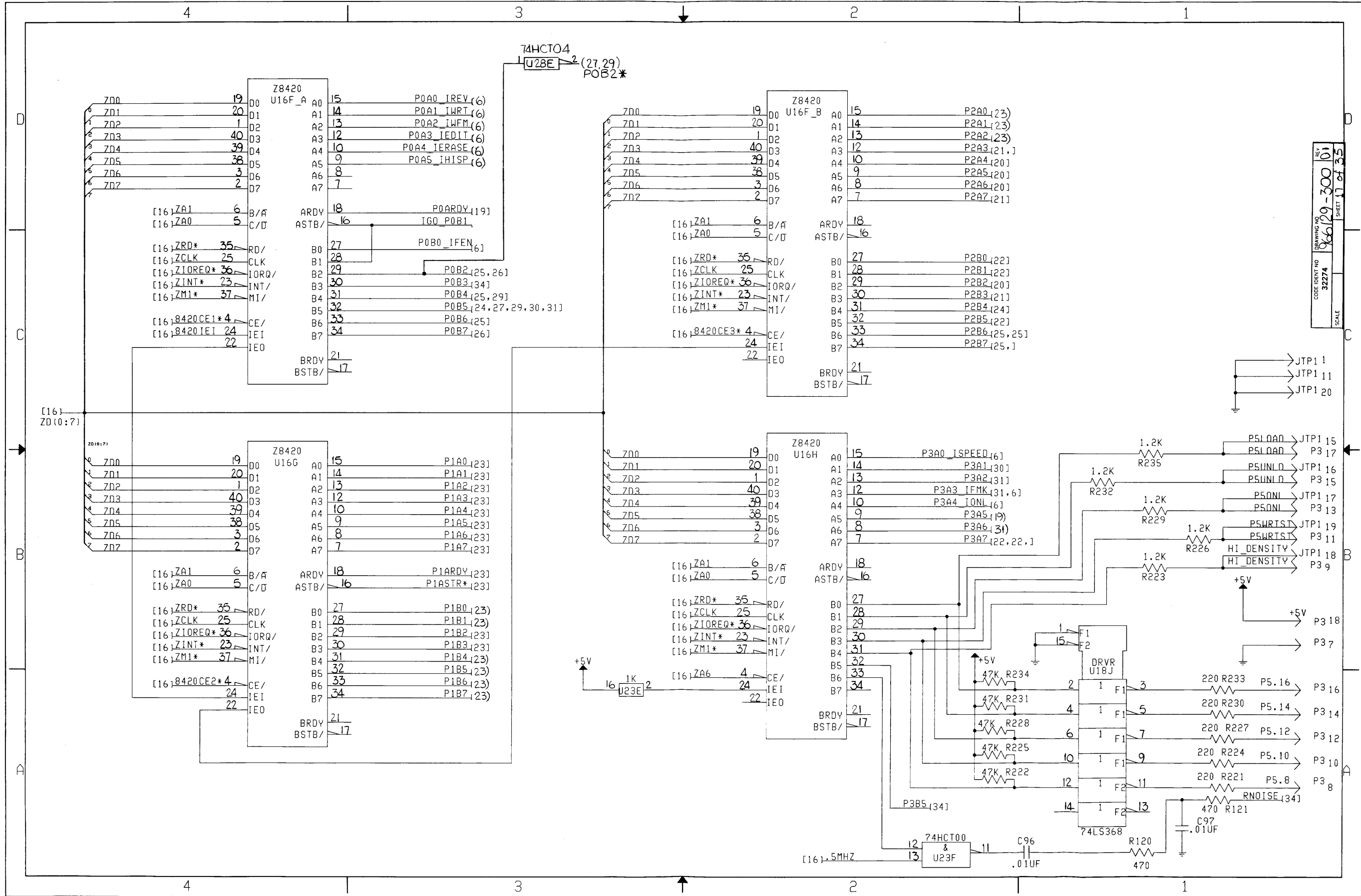

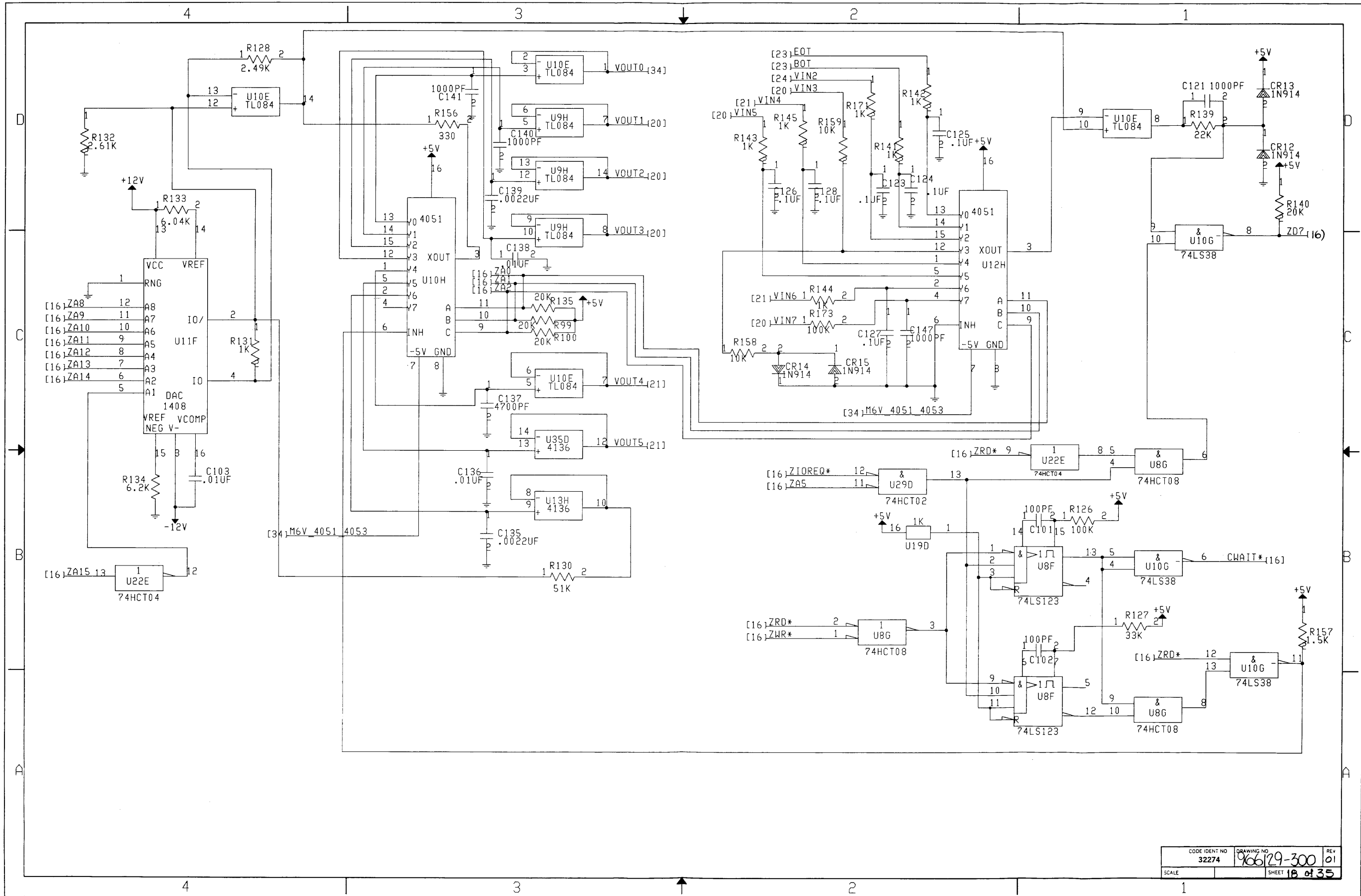

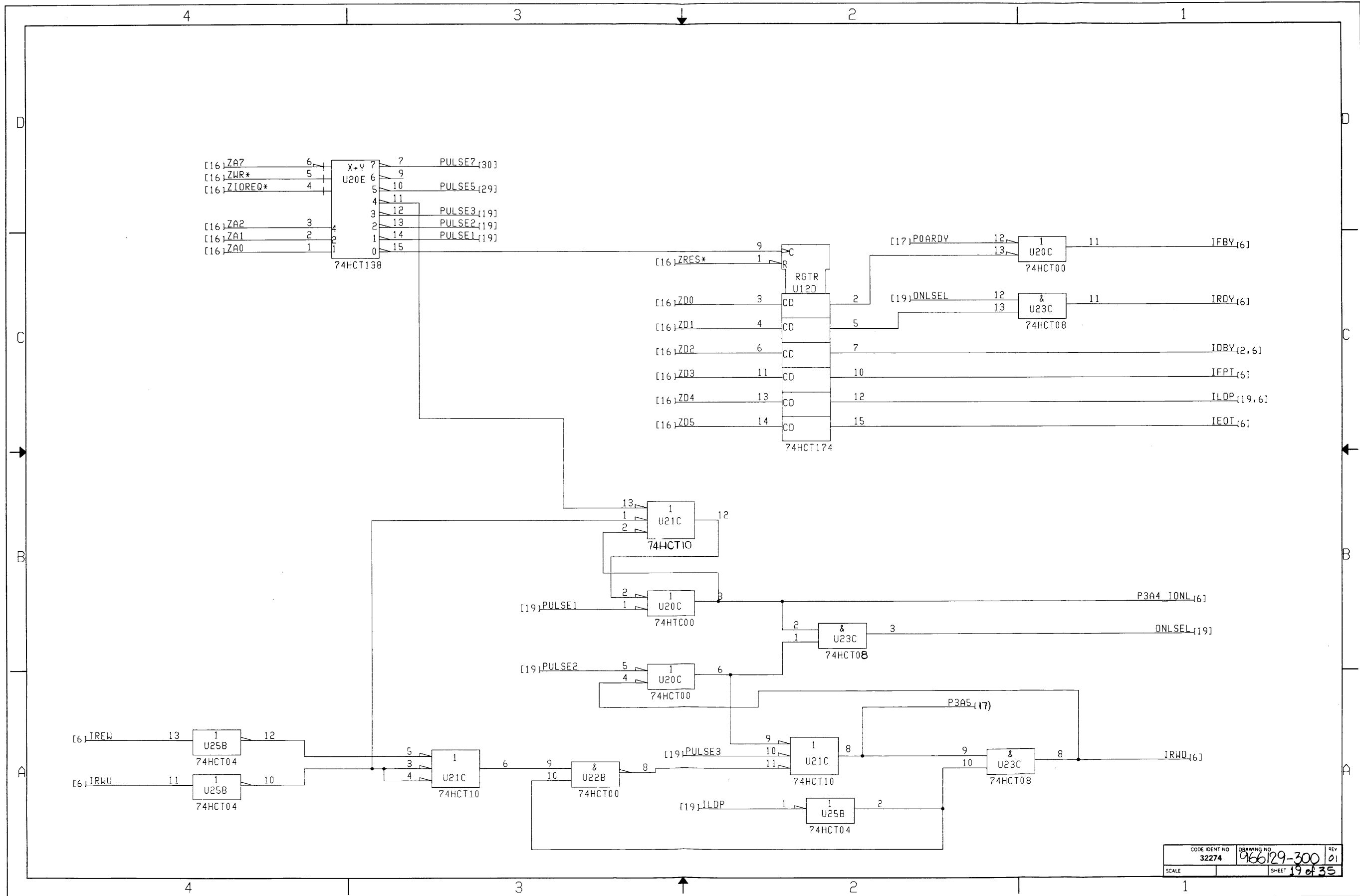

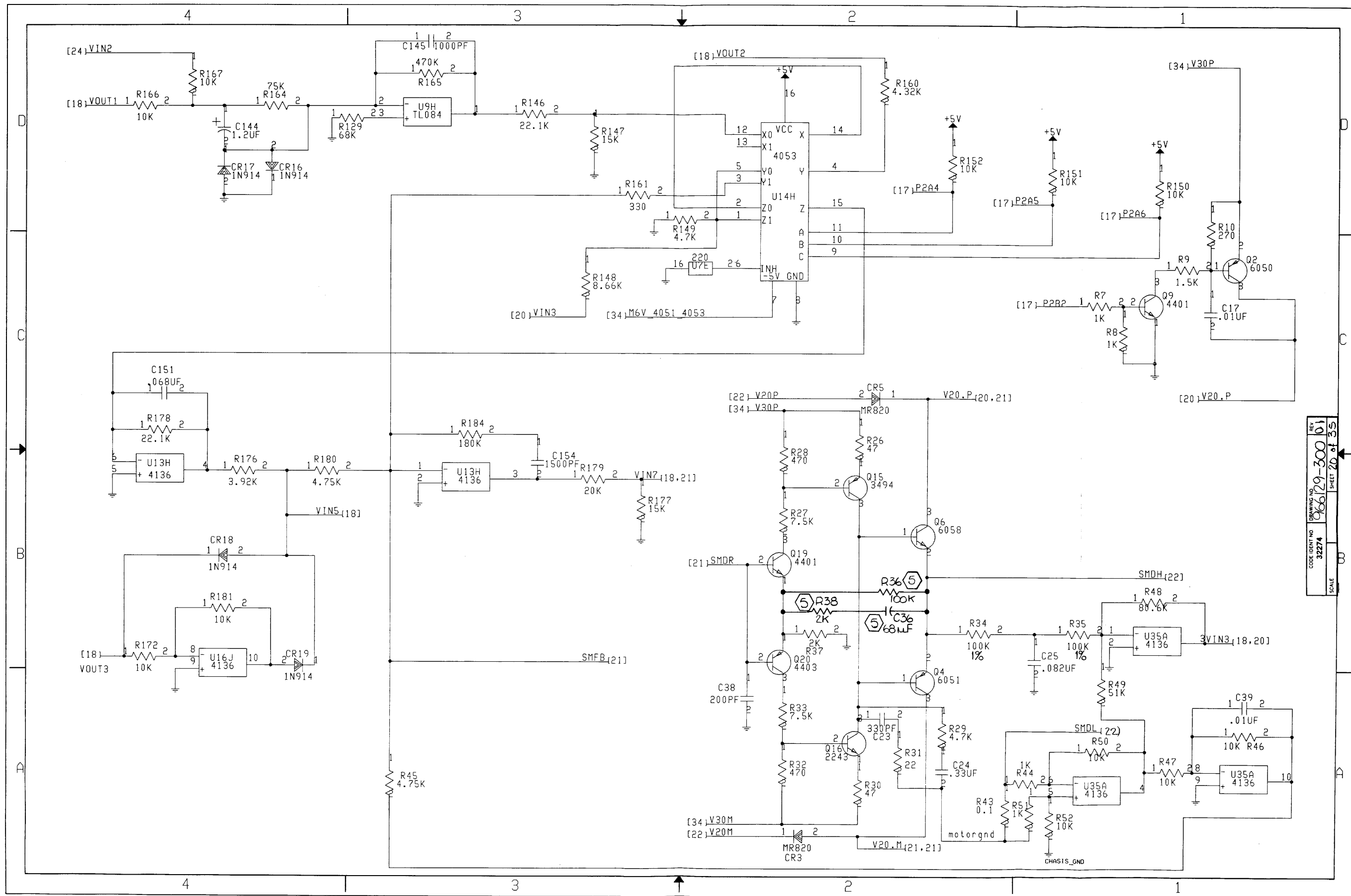

CODE IDENT NO 32274
 DRAWING NO 96629-300
 REV 01
 SHEET 20 of 35
 SCALE

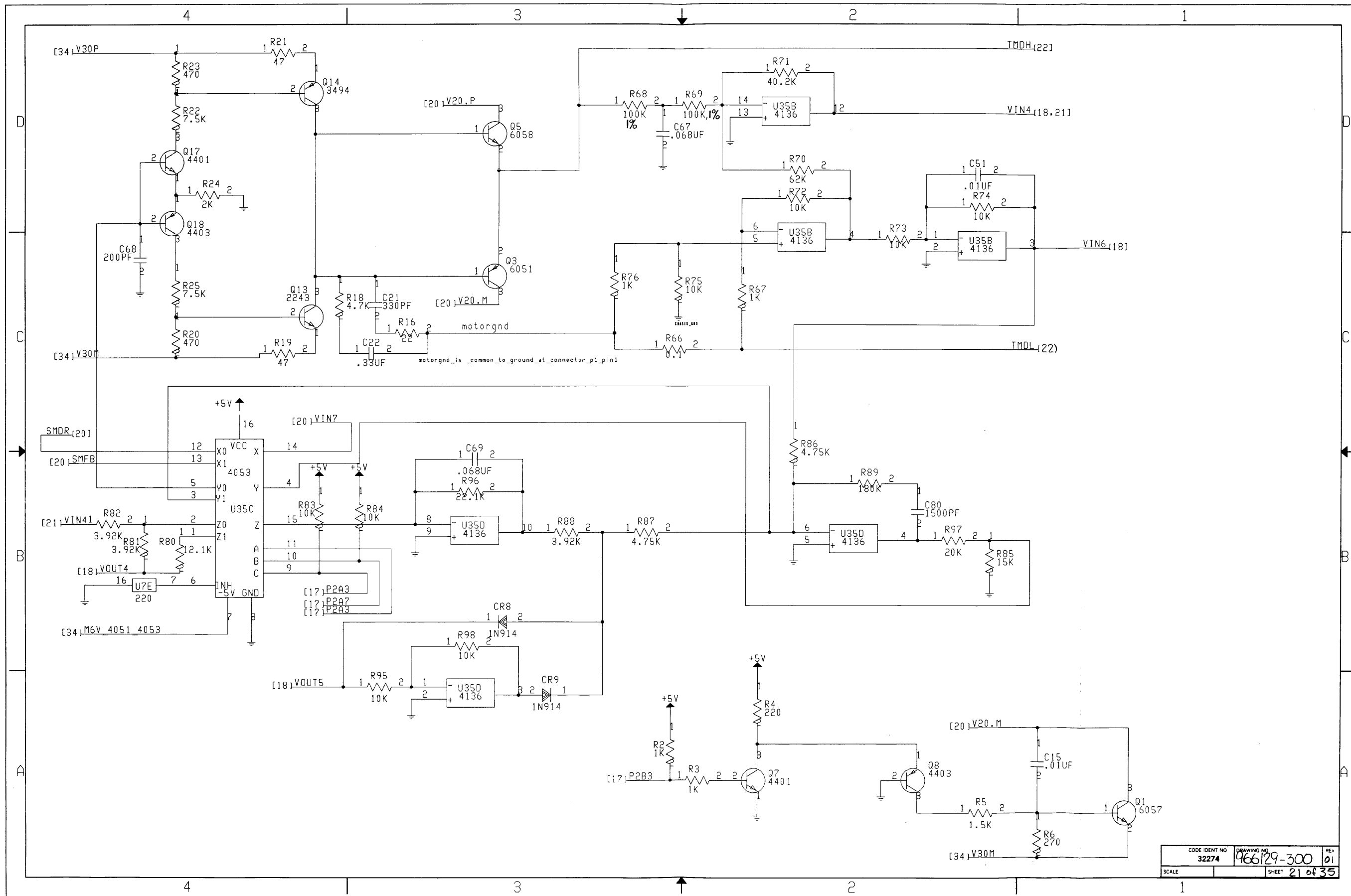

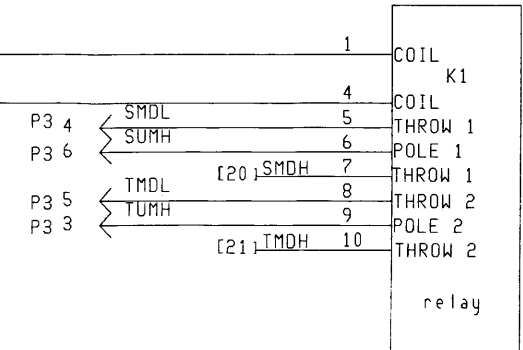
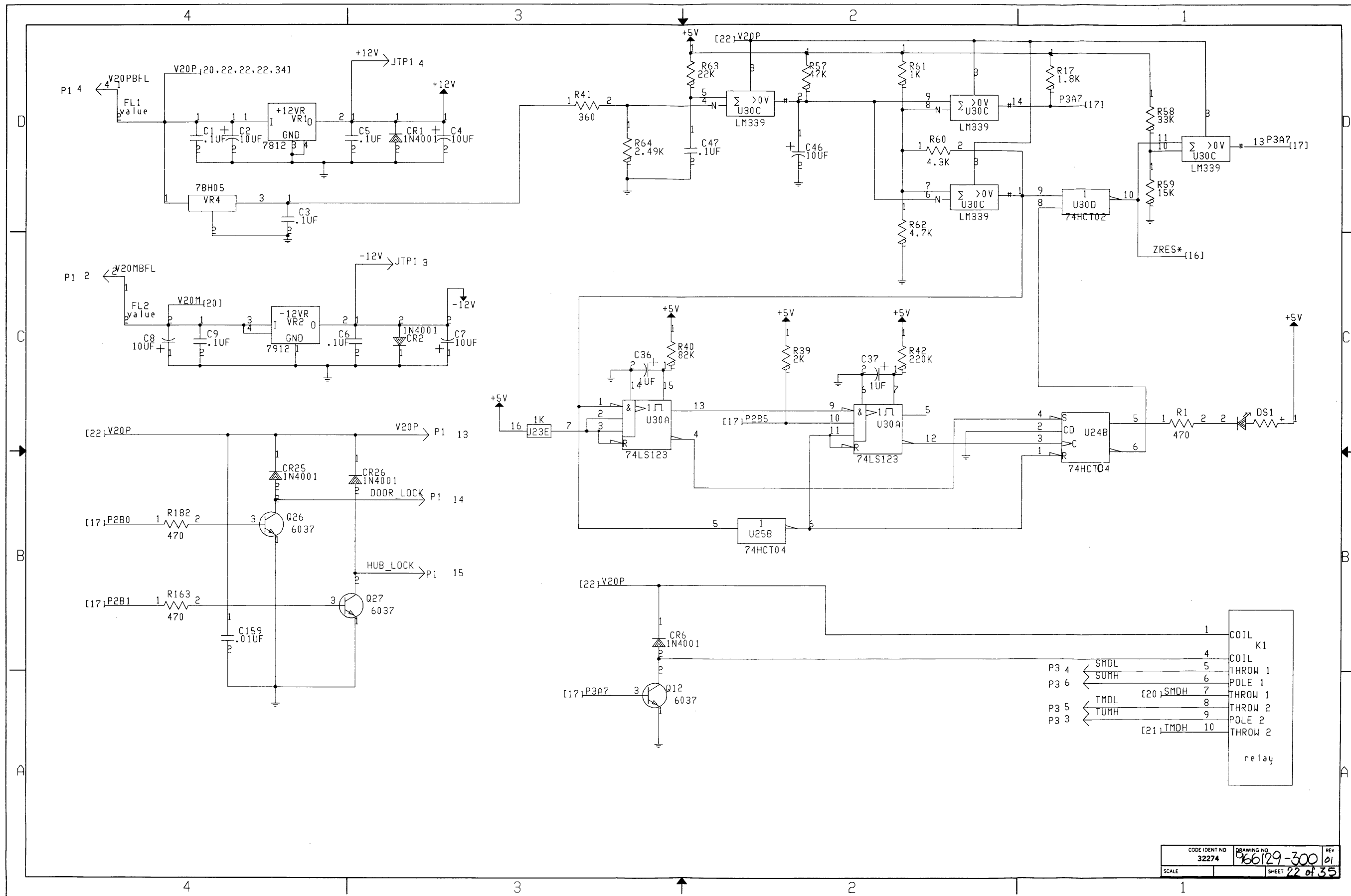

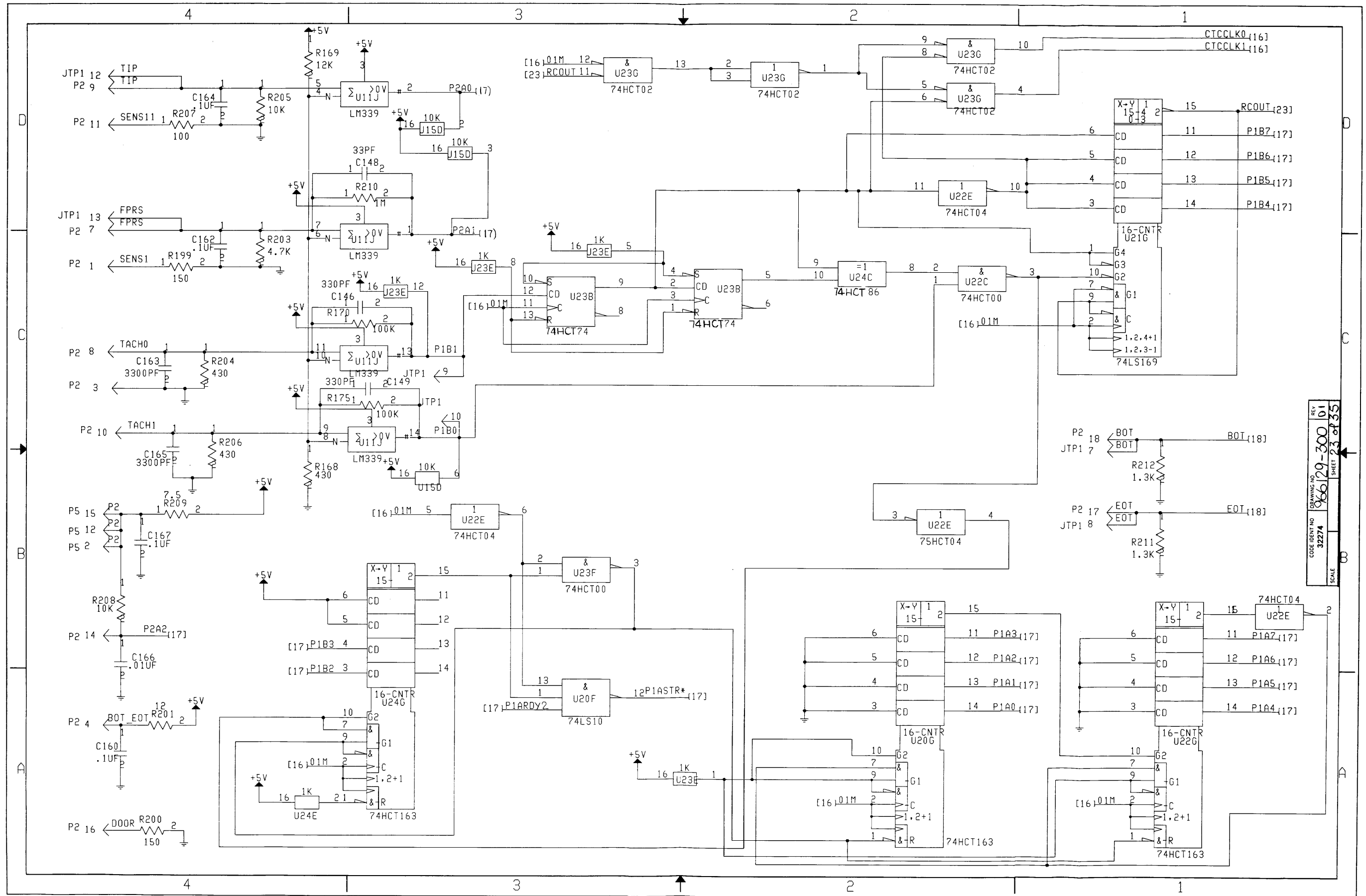

DRAWING NO. 32274
 REV. 01
 866129-300
 SHEET 23 of 35
 SCALE

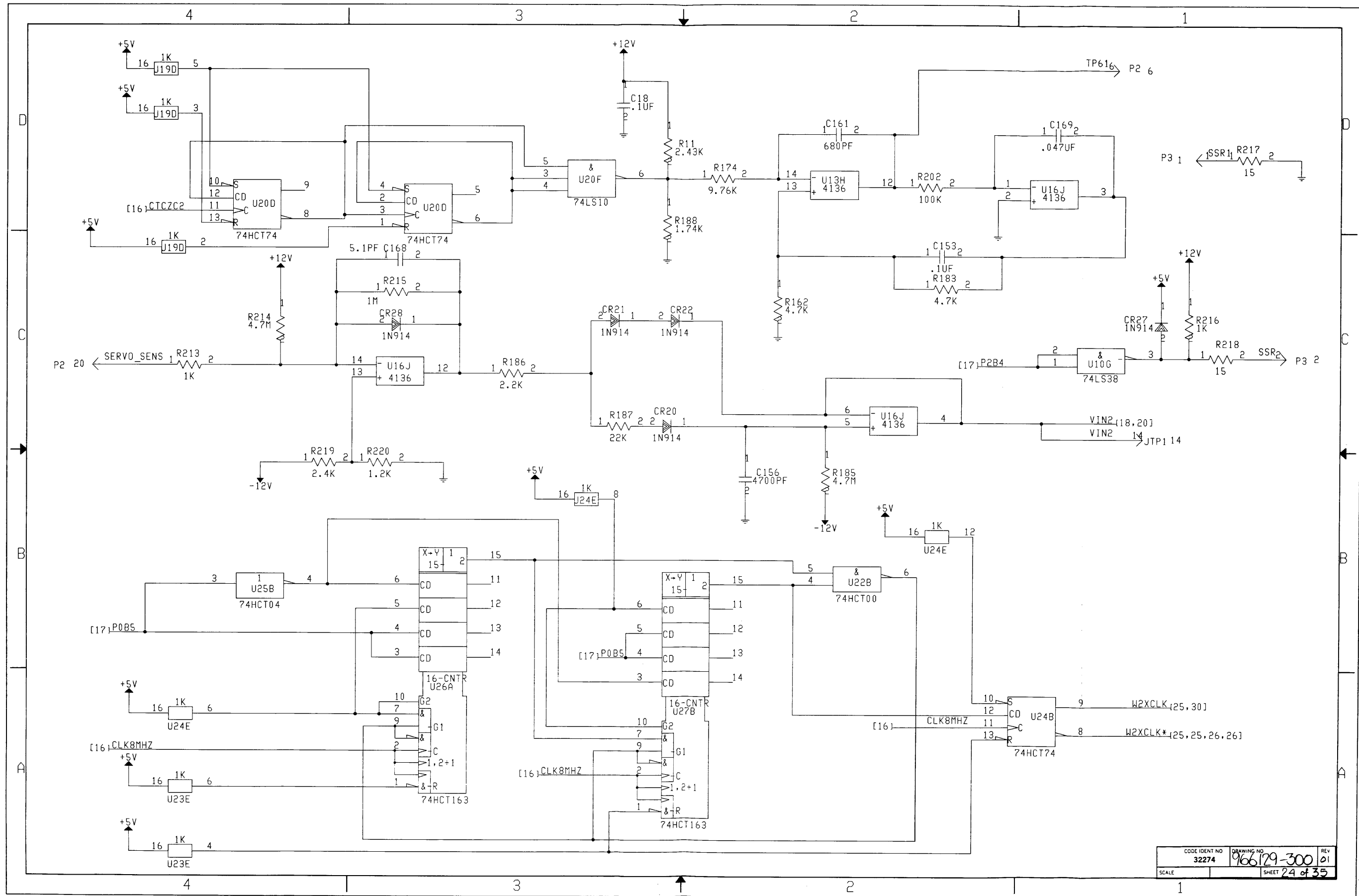

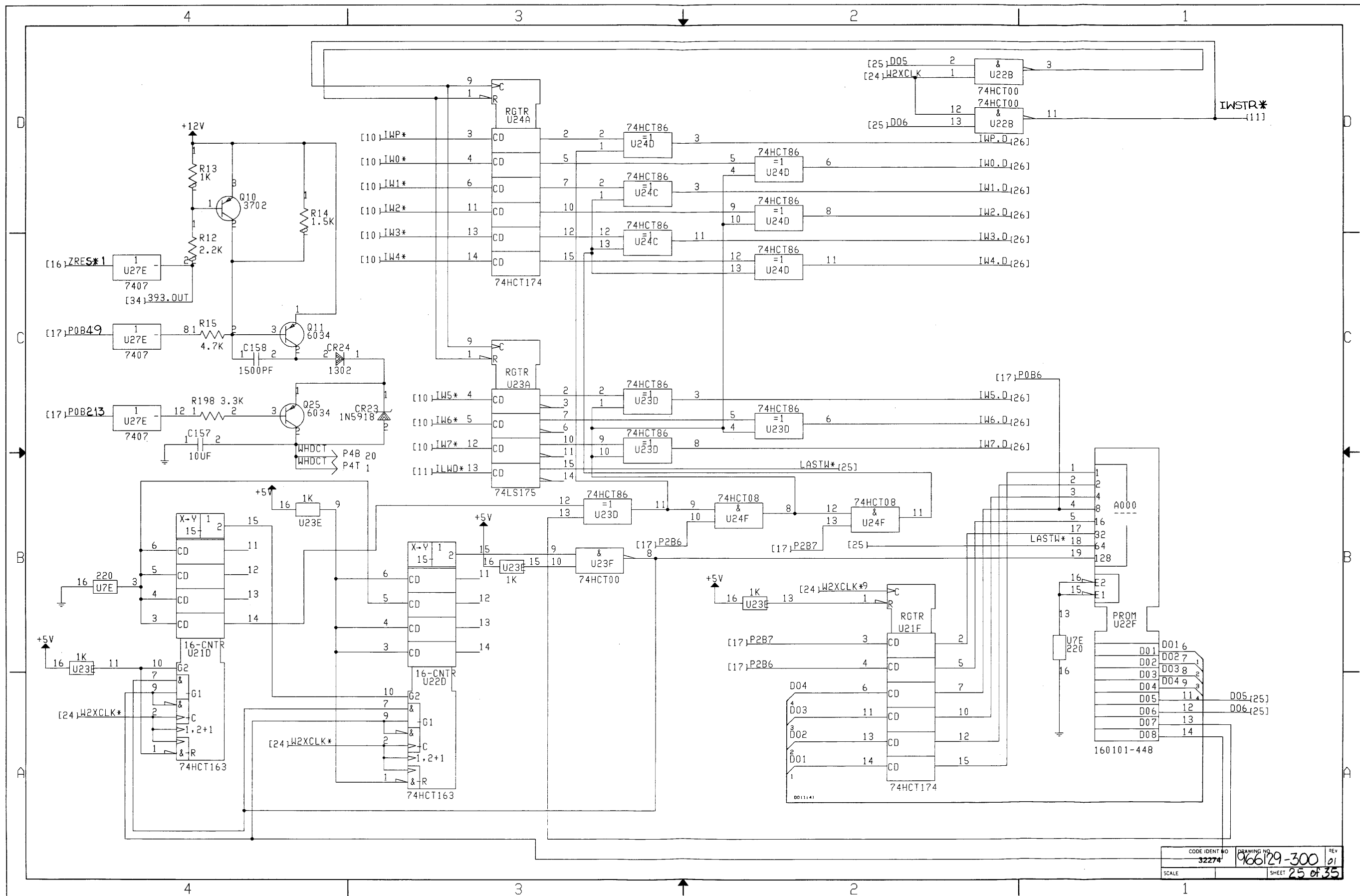

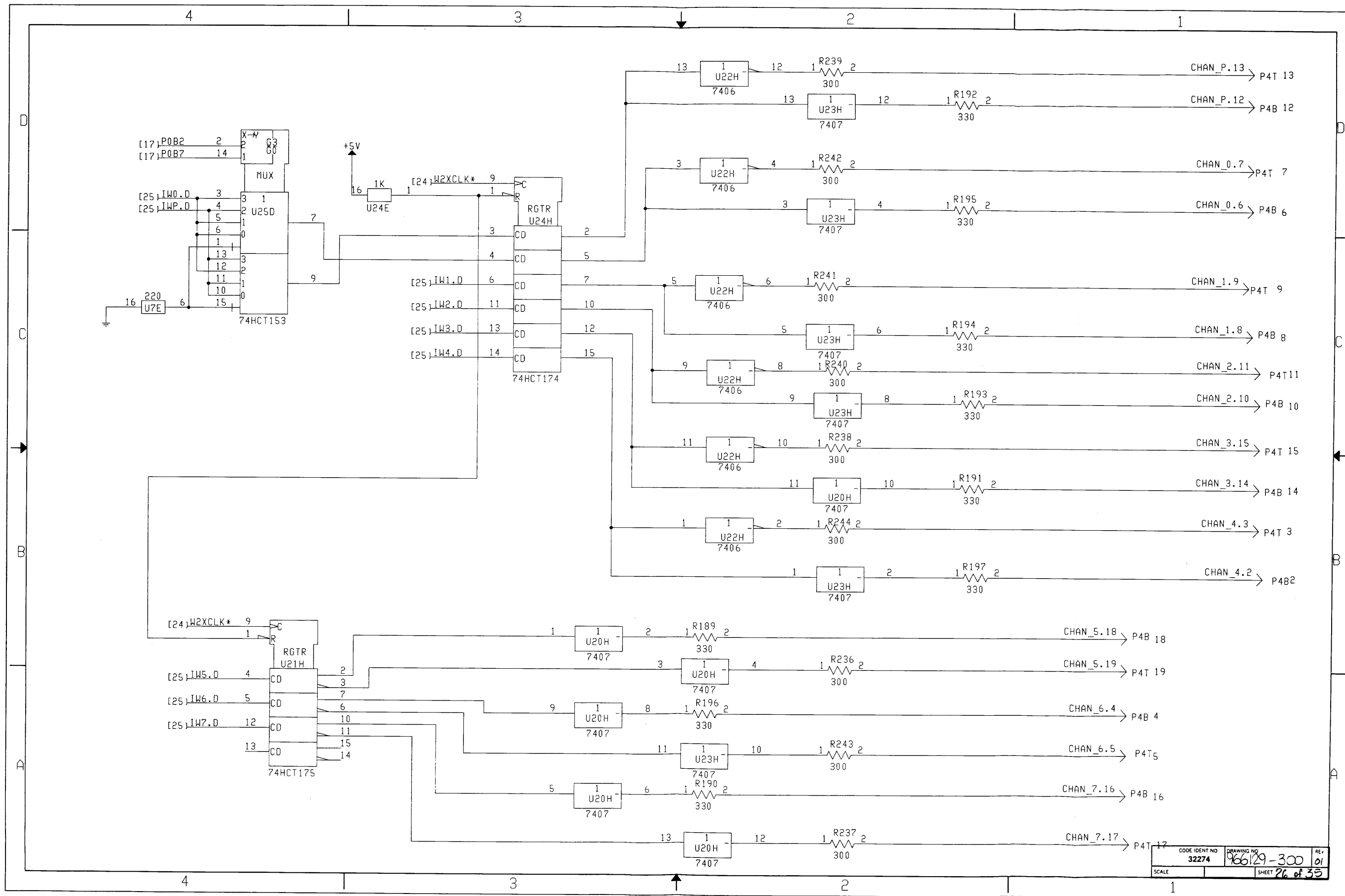

CODE IDENT NO 32274	DRAWING NO 966129-300	REV 01
SCALE	SHEET 26 of 35	

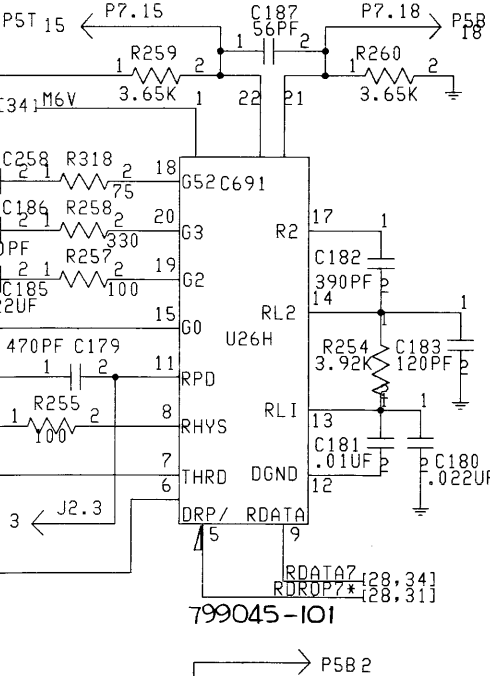
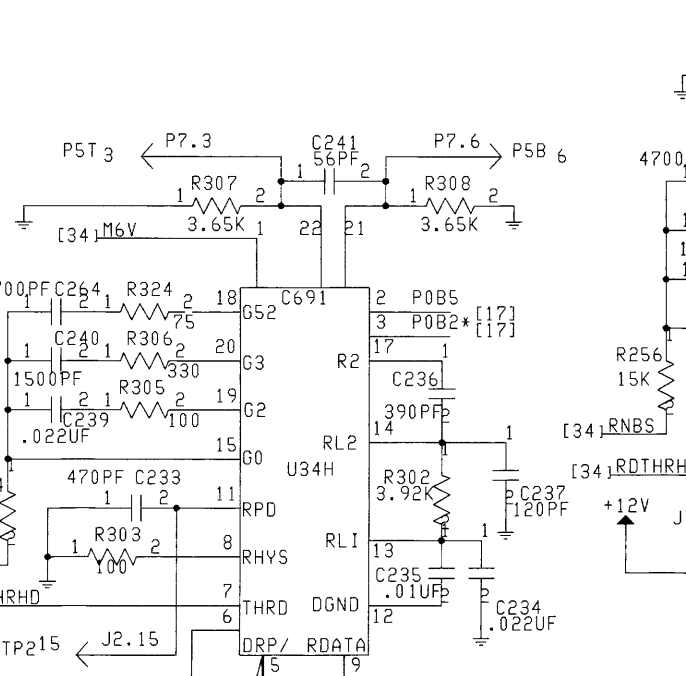
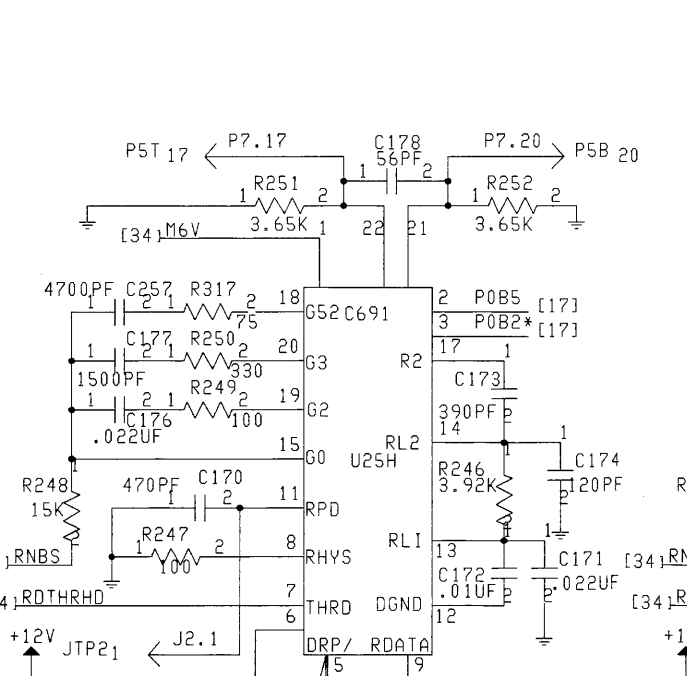
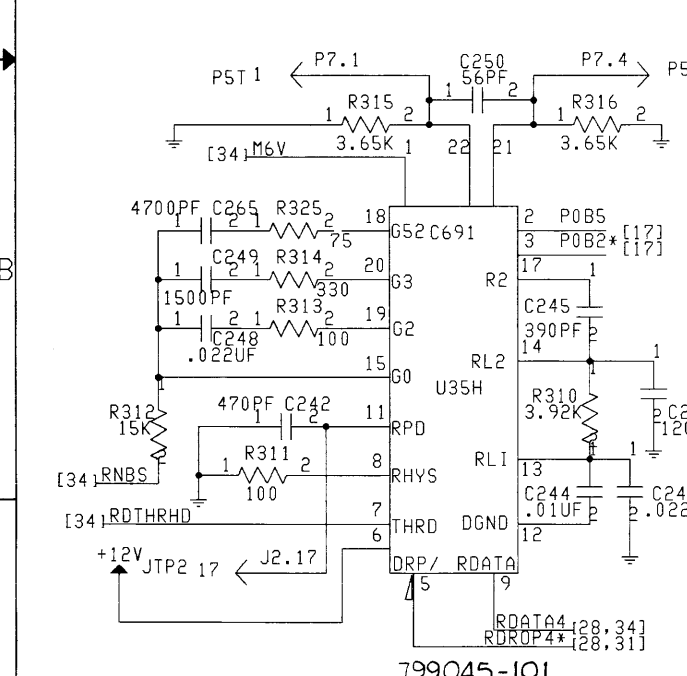
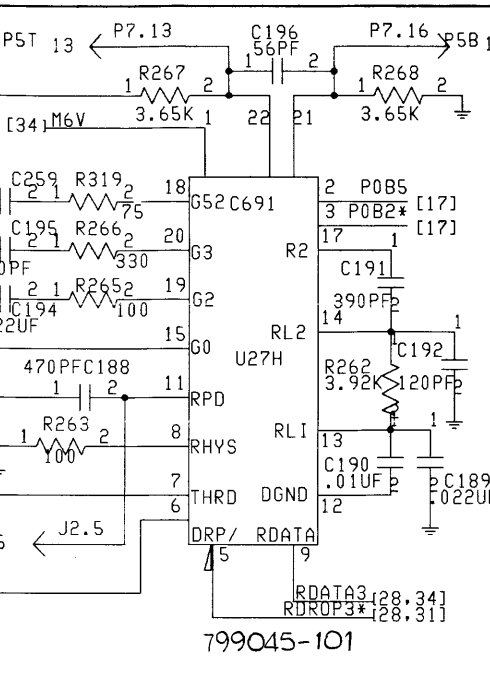
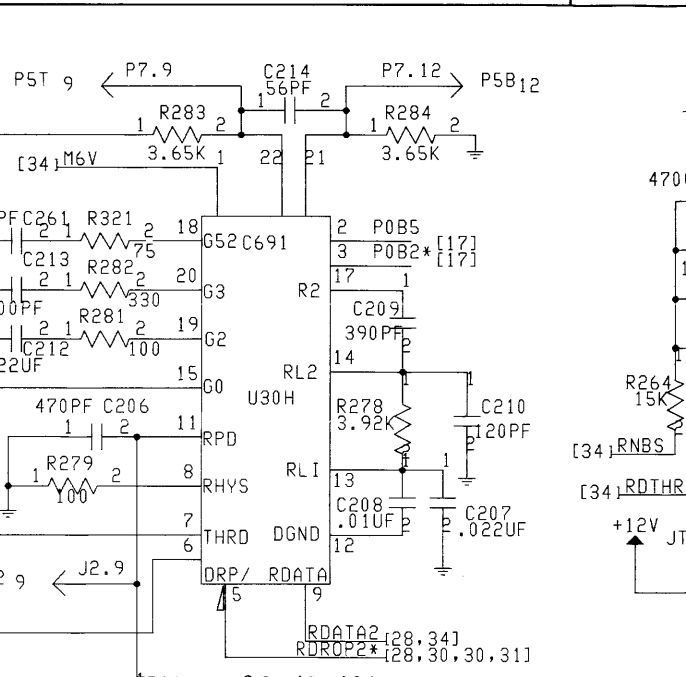
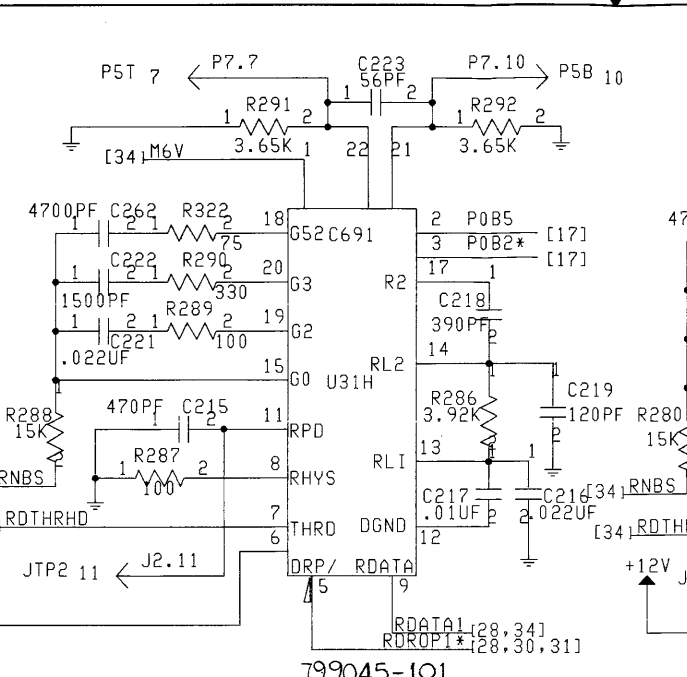
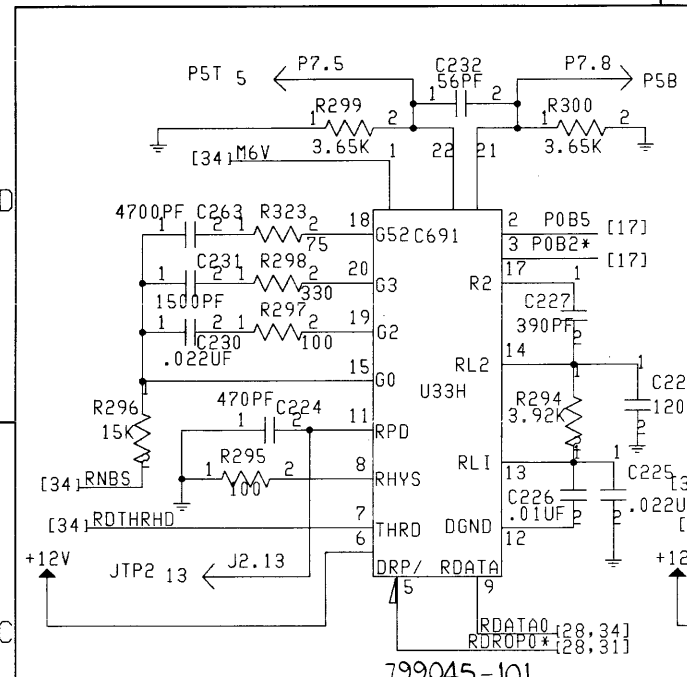
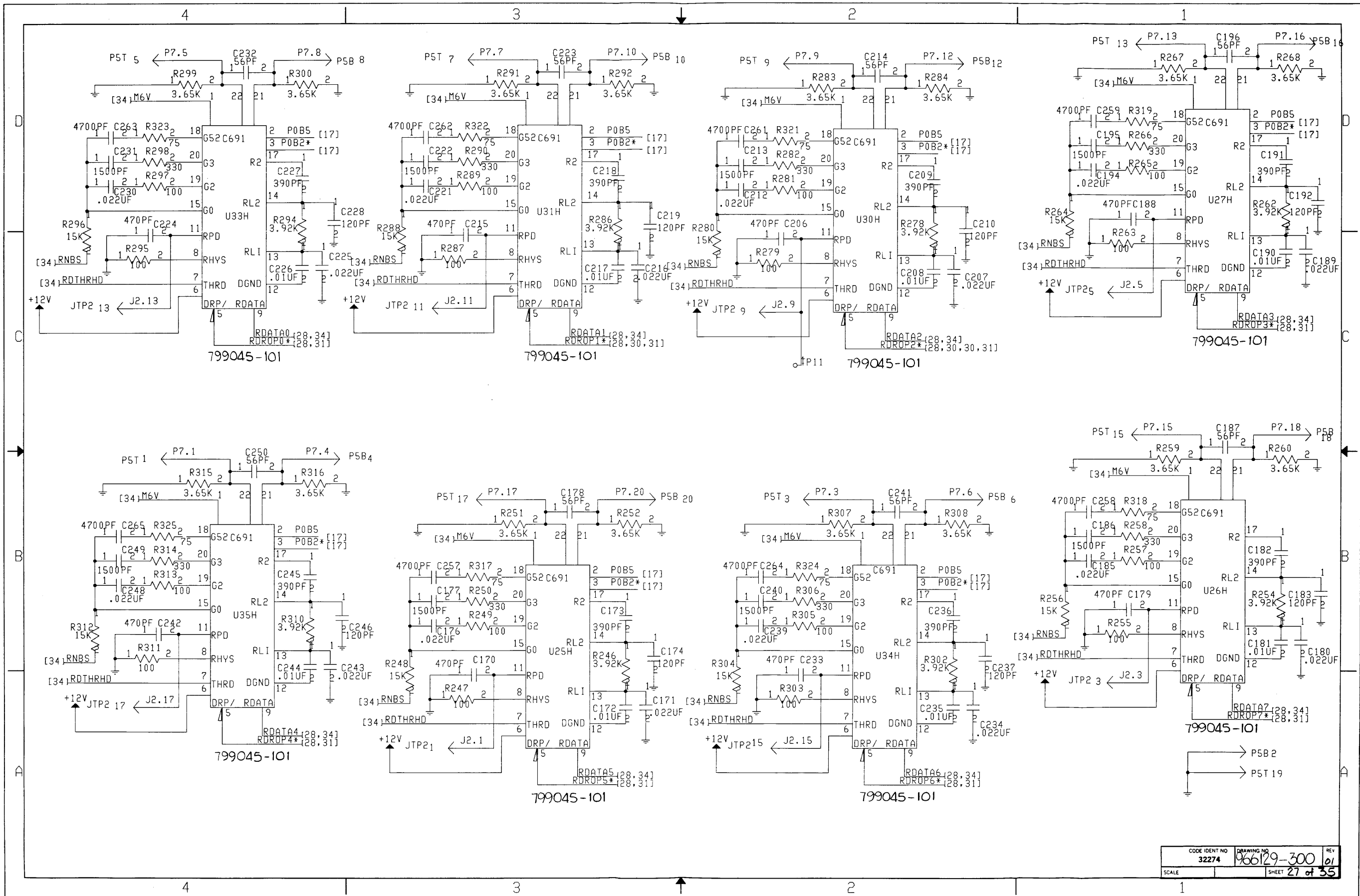

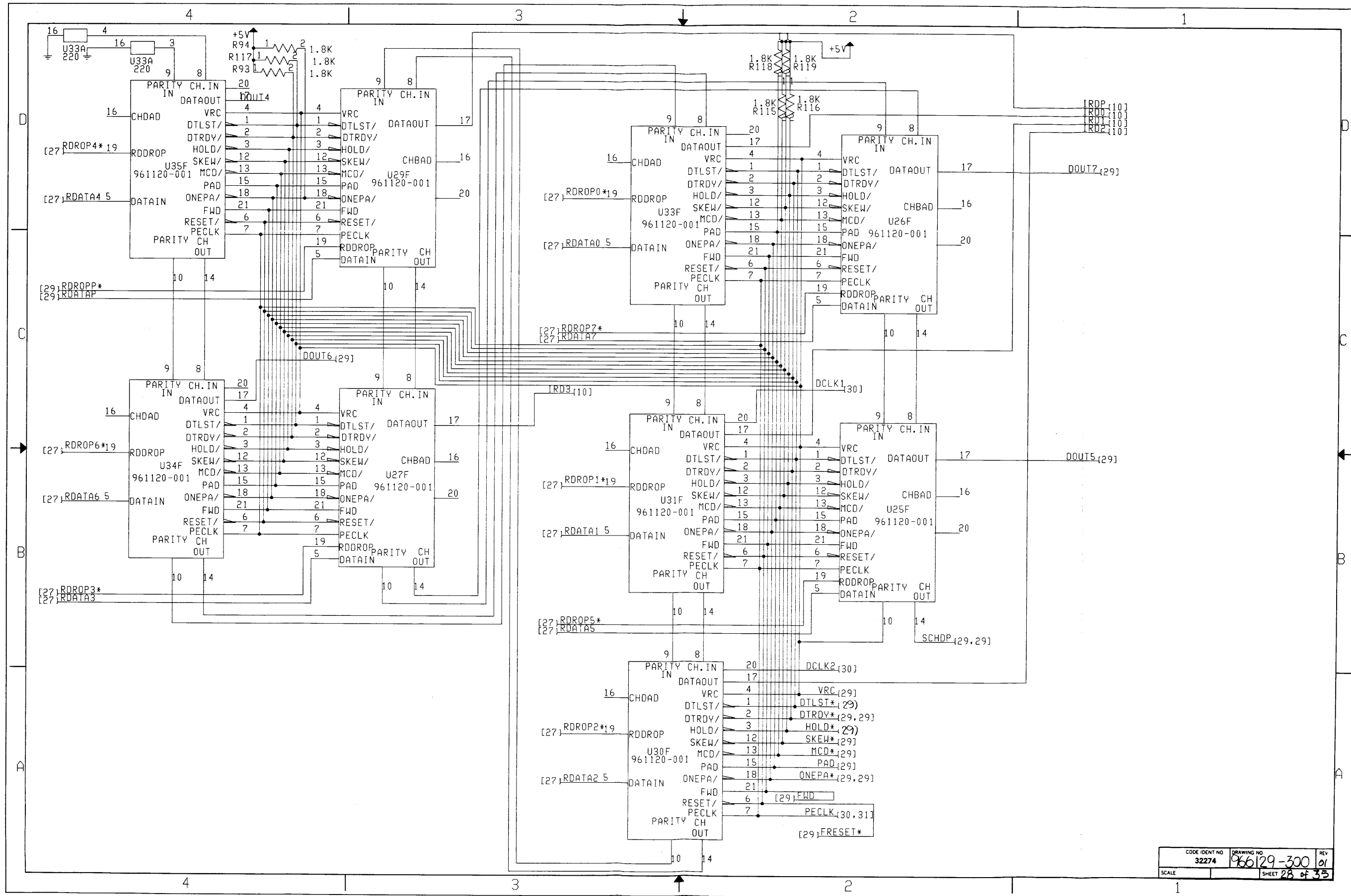

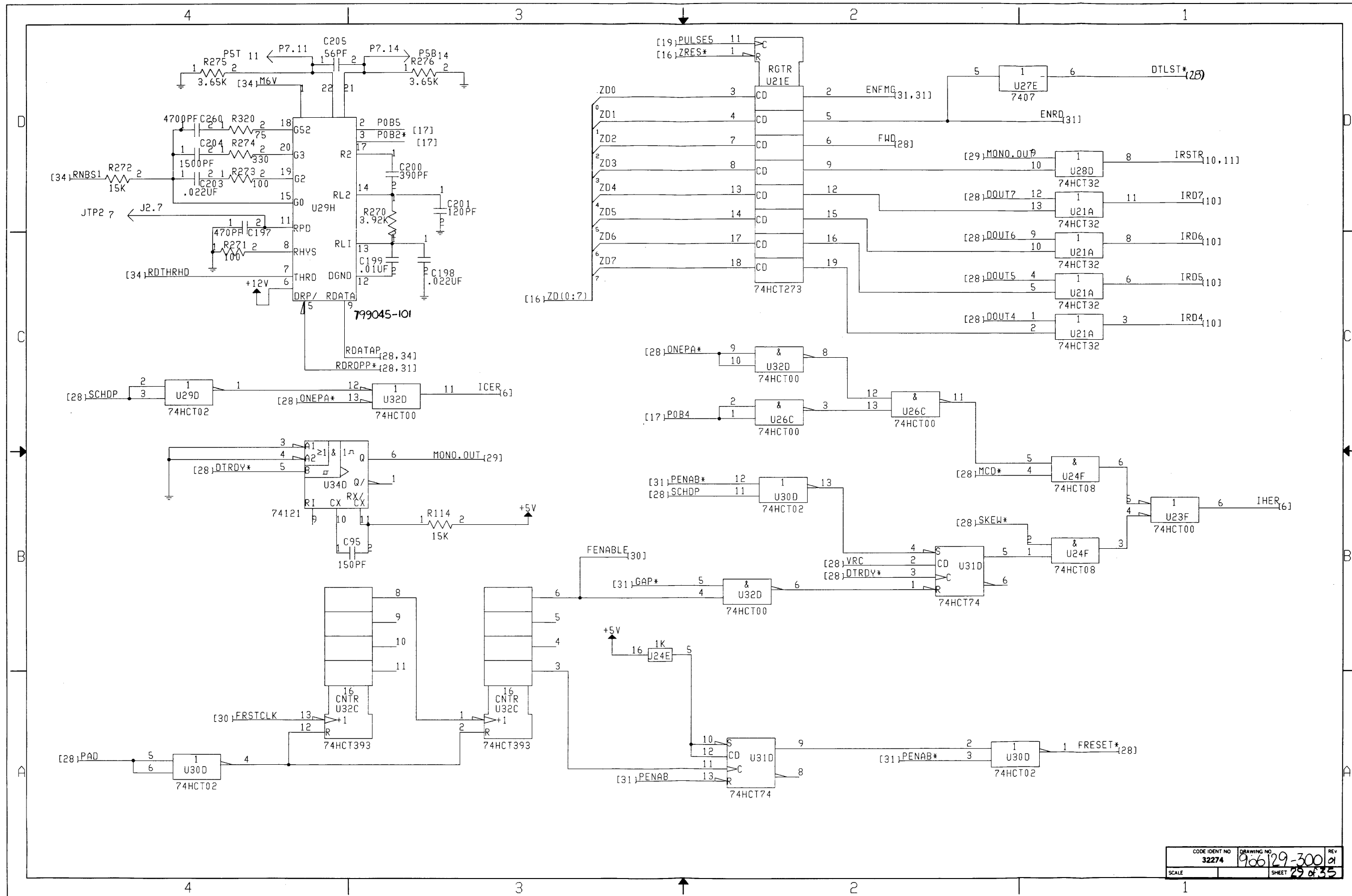

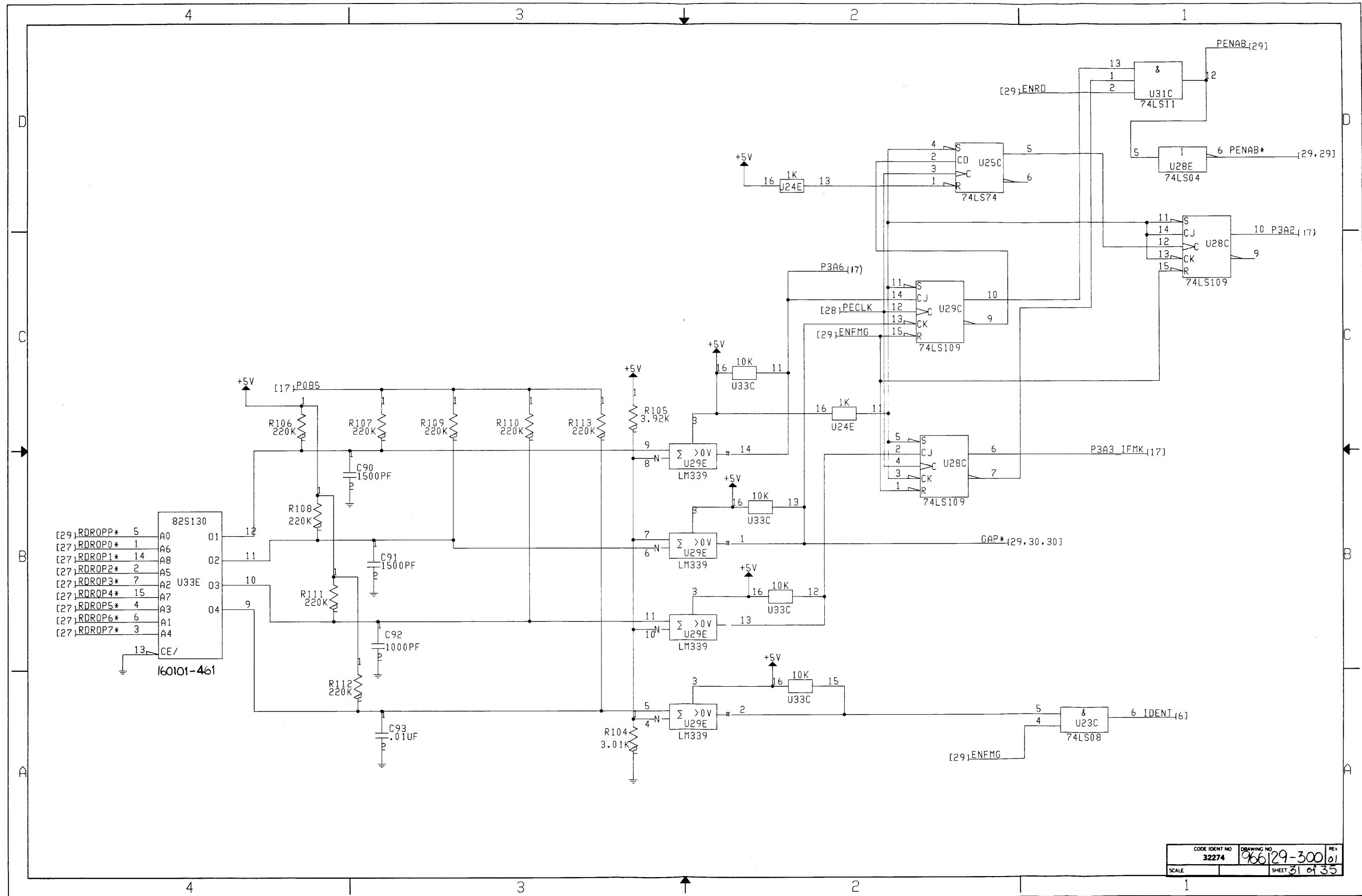

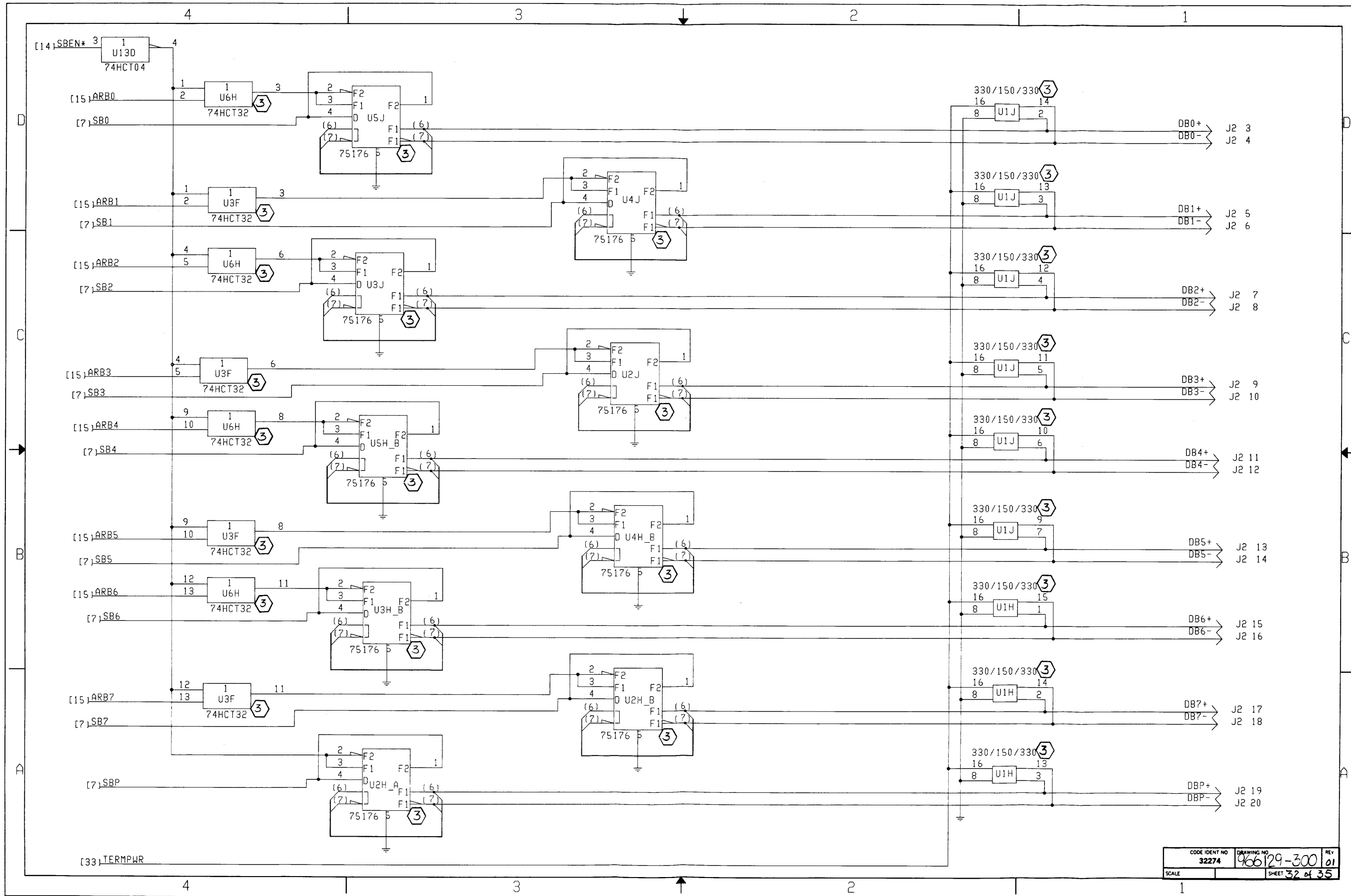

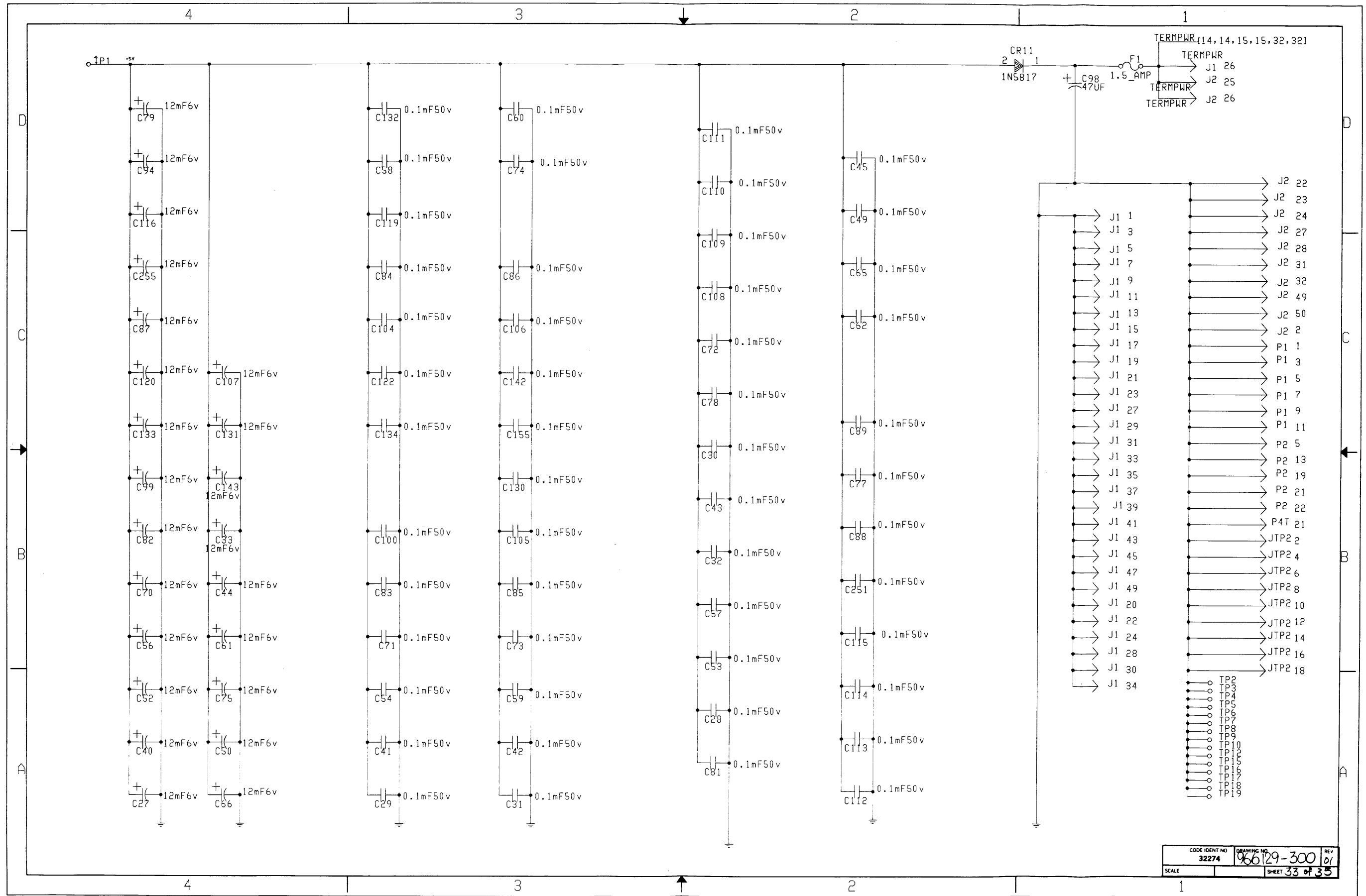

CODE IDENT NO 32274	DRAWING NO 966129-300	REV 01
SCALE	SHEET 33 of 35	

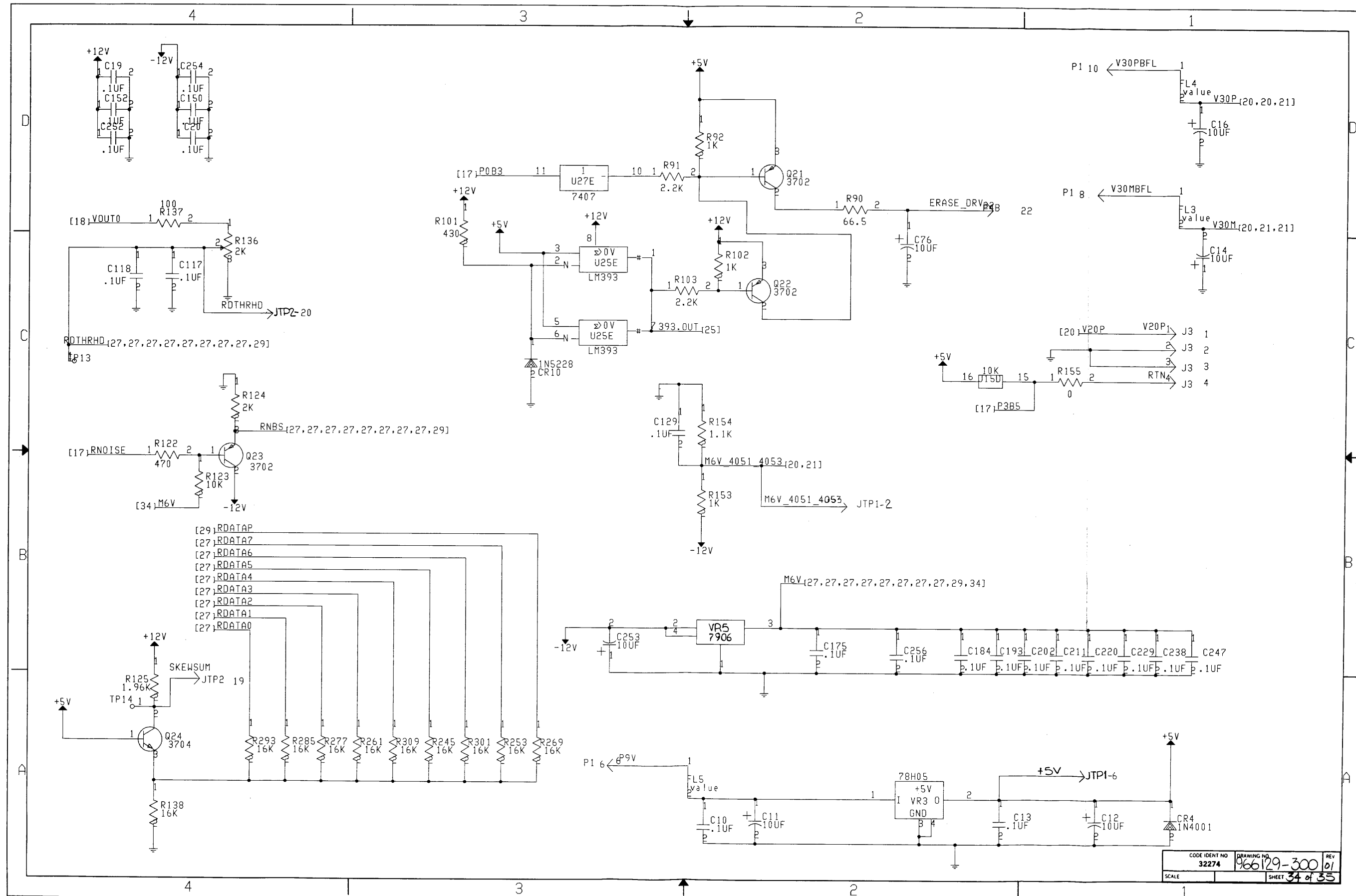

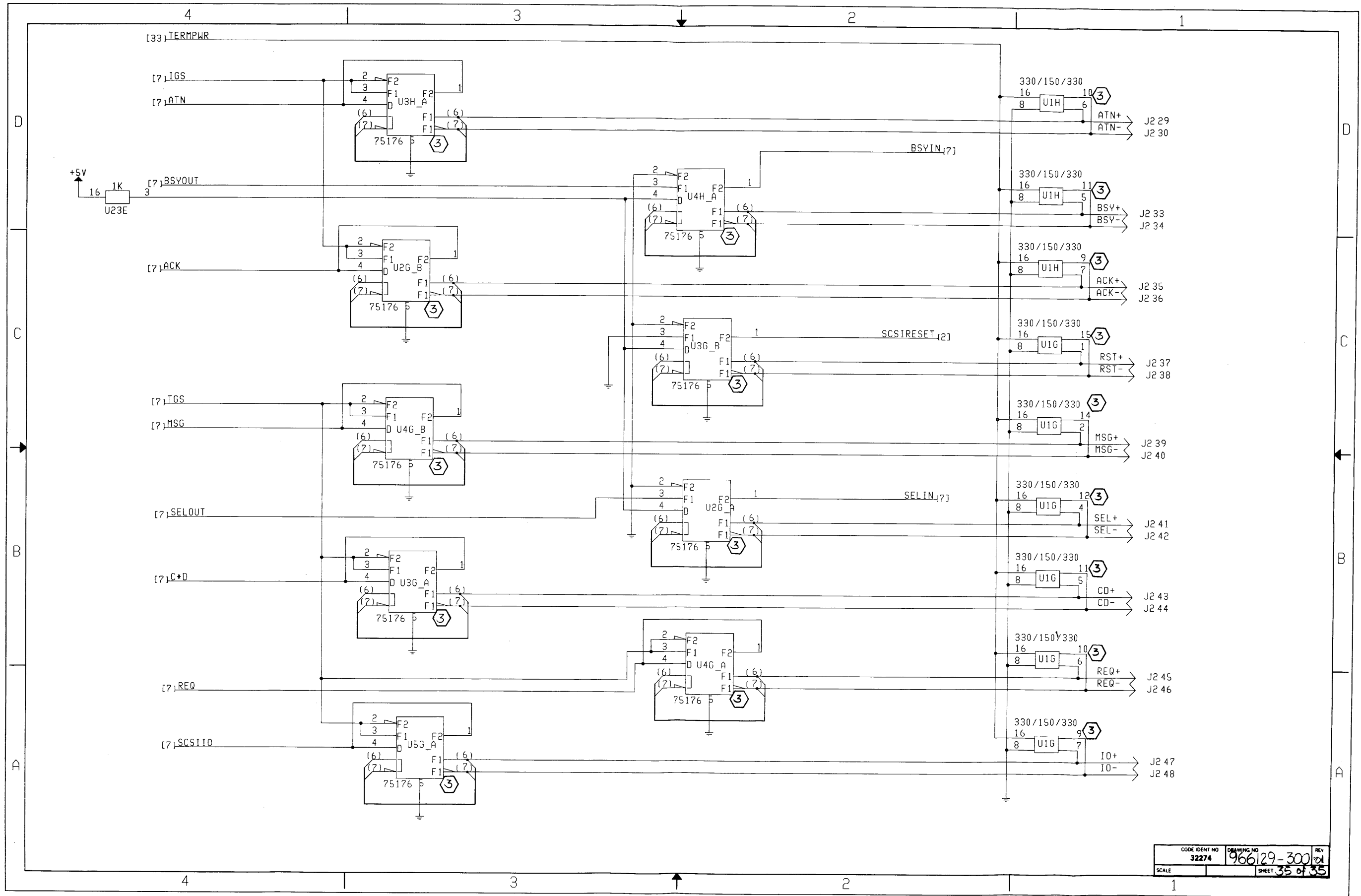

REVISION					
LTR	DESCRIPTION	OWN	DATE	APVD	DATE
A	PROD REL EPO SD-034B	UA	2-23-72	SA	7-72
B	INCORP EGO 30372	KAN	3-22-72	X	7-72

TABLE 1

INPUT VAC	FUSE REQUIRED
100V	3 AG 3 AMP
120V	
220V	
230V	3 AG 1 1/2 AMP
240V	

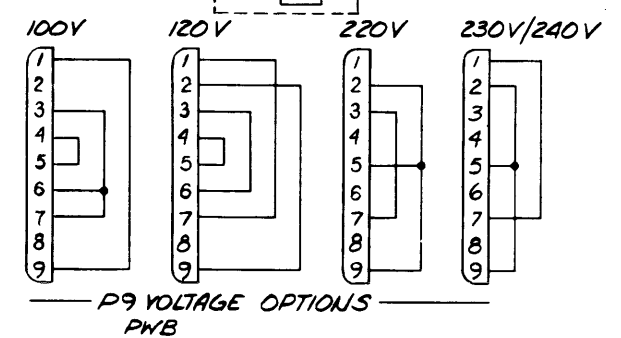
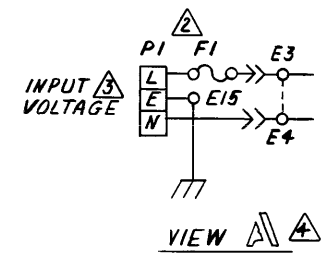
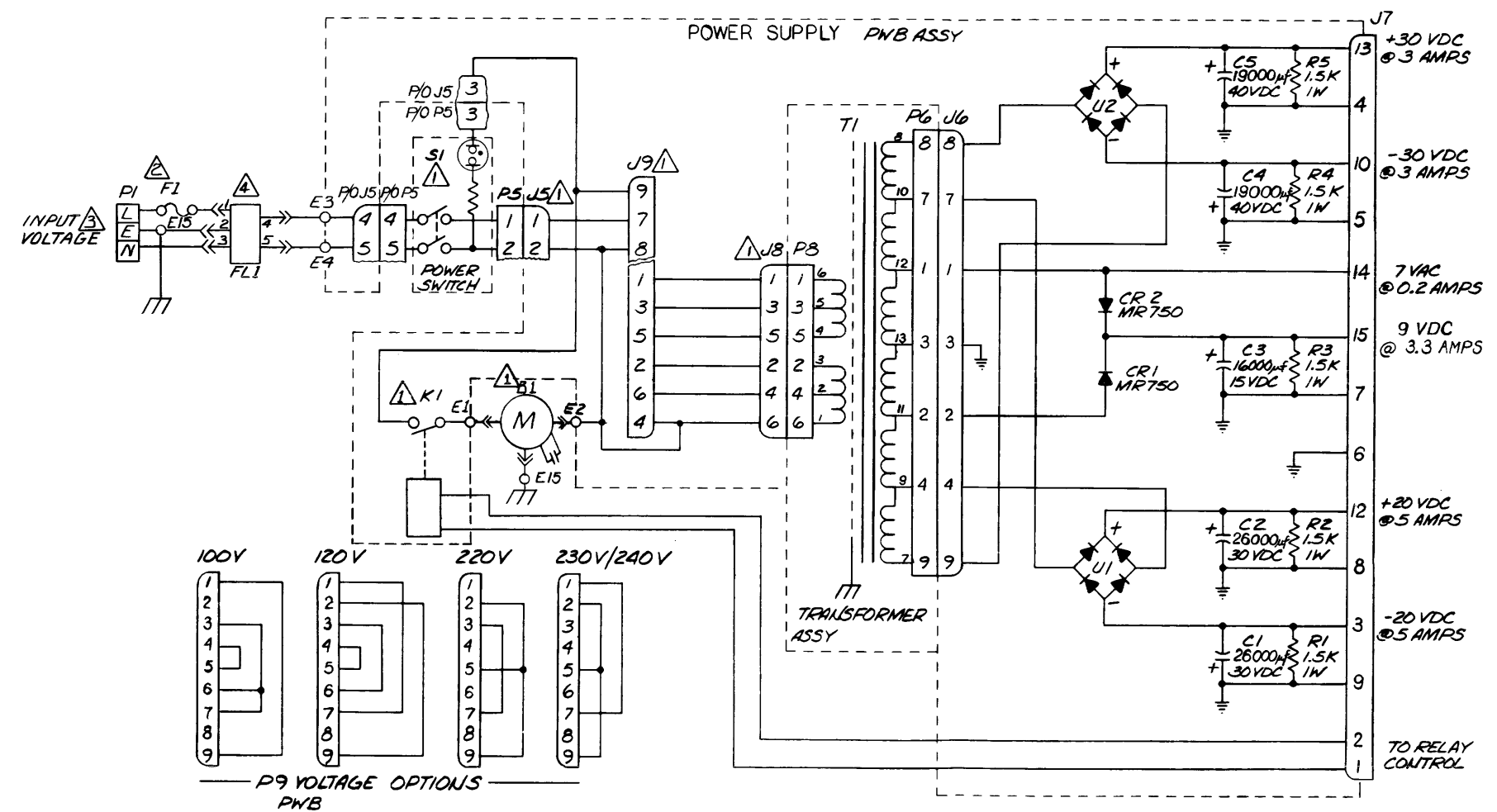

960877-300
REV B

- NOTES:
- FOR UNITS WITHOUT LINE FILTER, SEE VIEW A.
 - FOR INPUT VOLTAGE SEE TABLE 1.
 - FOR FUSE SELECTION SEE TABLE 1.
 - PARTS NOTED AFFECT UL RECOGNITION.

UNLESS OTHERWISE SPECIFIED DIMENSIONS ARE IN INCHES
TOLERANCES ARE DECIMALS
X = .XX
XX = .XXX
XXX = .XXXX
ANGLES DO NOT SCALE
DRAWING

REV STATUS	REV	1	2	3	4	5	6	7	8	9	10	11	12	13	14	15	16	17	18	19	20	21	22	23	24
OF SHEETS	SH	1	2	3	4	5	6	7	8	9	10	11	12	13	14	15	16	17	18	19	20	21	22	23	24
APPROVAL		DATE																							
DESIGN		DATE		TITLE: SCHEMATIC - POWER SUPPLY																					
SAFETY		DATE		CODE IDENT: 32274																					
DES MGR		DATE		SIZE: D																					
MFG ENG		DATE		DWG NO: 960877-300																					
ISSUED		DATE		SCALE:																					

REVISION				
LTR	DESCRIPTION	OWN	DATE	APVD
A	ENGR. RELEASE	LL	7/21/80	NT
B	INCORP ECO 7851	RL	7/22/80	7/21/80
C	INCORP ECO 8028	LS	8-13-80	8/20/80

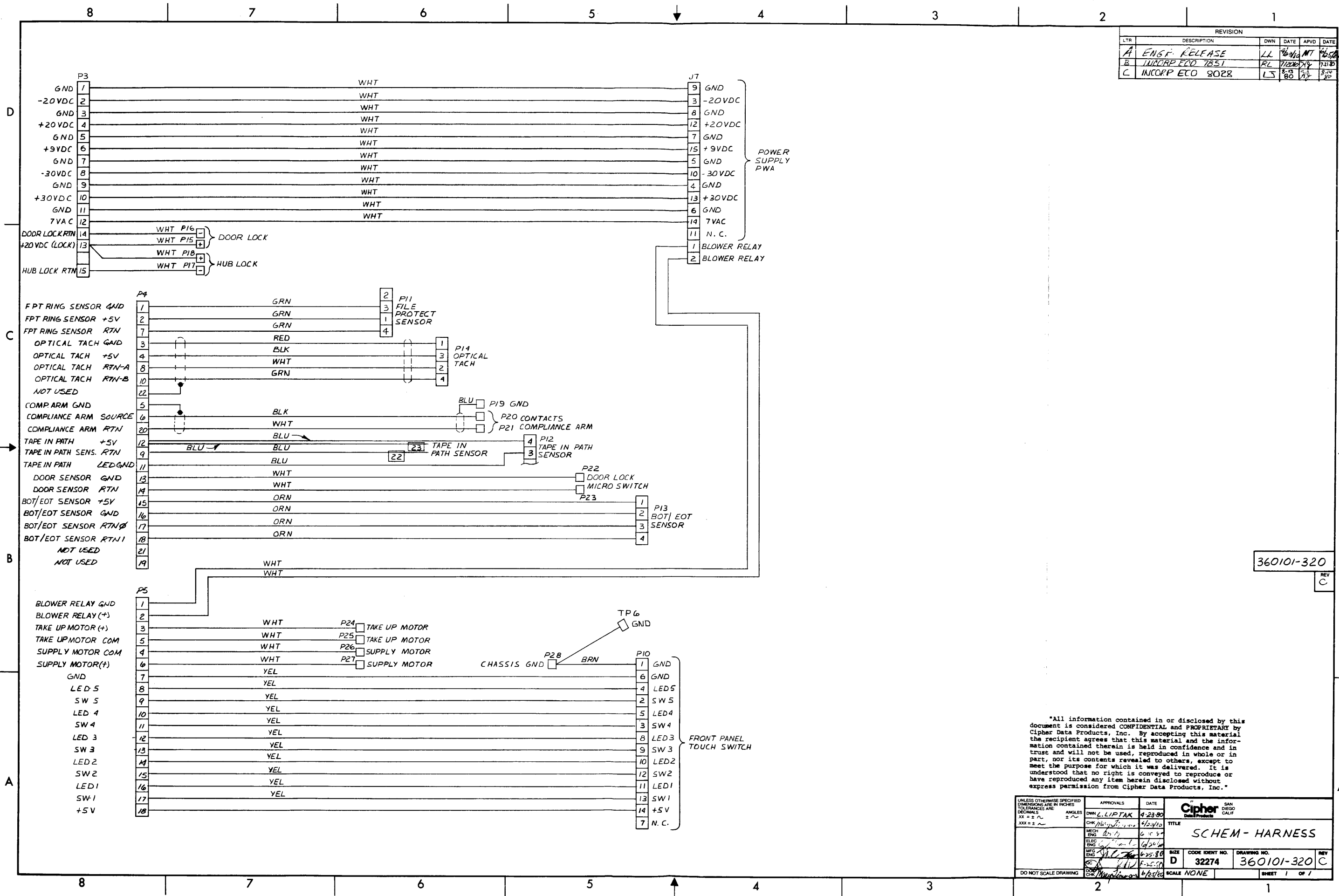

360101-320
REV C

"All information contained in or disclosed by this document is considered CONFIDENTIAL and PROPRIETARY by Cipher Data Products, Inc. By accepting this material the recipient agrees that this material and the information contained therein is held in confidence and in trust and will not be used, reproduced in whole or in part, nor its contents revealed to others, except to meet the purpose for which it was delivered. It is understood that no right is conveyed to reproduce or have reproduced any item herein disclosed without express permission from Cipher Data Products, Inc."

UNLESS OTHERWISE SPECIFIED DIMENSIONS ARE IN INCHES TOLERANCES ARE DECIMALS XX ± .XX ANGLES ± .1°		APPROVALS	DATE	CIPHER Data Products SAN DIEGO CALIF
OWN	C. LIPTAK	4-23-80		
CHK		6/23/80		
MECH ENG		6-25-80		
ELEC ENG		6-25-80		
MFG ENG		6-25-80		SIZE D
CODE IDENT NO.	32274	DRAWING NO.	360101-320	REV C
DO NOT SCALE DRAWING	SCALE NONE	SHEET	1 OF 1	

REVISION				
LTR	DESCRIPTION	OWN	DATE	APD
A	PROD REL ERO 2D-PP-0155	FN	4/2/89	89

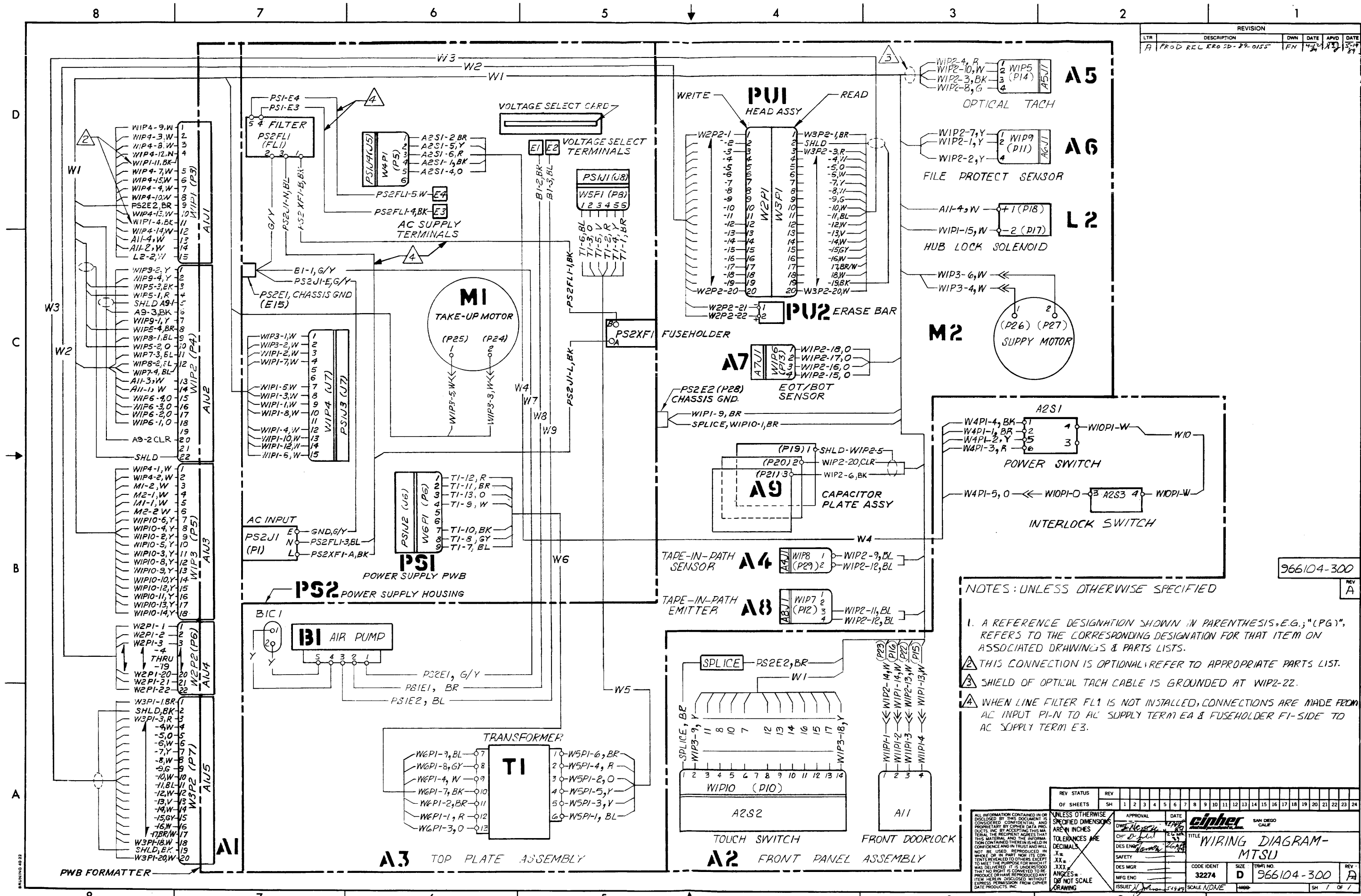

NOTES: UNLESS OTHERWISE SPECIFIED

1. A REFERENCE DESIGNATION SHOWN IN PARENTHESIS, E.G., "(P6)", REFERS TO THE CORRESPONDING DESIGNATION FOR THAT ITEM ON ASSOCIATED DRAWINGS & PARTS LISTS.
2. THIS CONNECTION IS OPTIONAL; REFER TO APPROPRIATE PARTS LIST.
3. SHIELD OF OPTICAL TACH CABLE IS GROUNDED AT WIP2-22.
4. WHEN LINE FILTER FL1 IS NOT INSTALLED, CONNECTIONS ARE MADE FROM AC INPUT PI-N TO AC SUPPLY TERM E4 & FUSEHOLDER FI-SIDE TO AC SUPPLY TERM E3.

REV STATUS	REV	DATE	APPROVAL
OF SHEETS	SH	1 2 3 4 5 6 7 8 9 10 11 12 13 14 15 16 17 18 19 20 21 22 23 24	

UNLESS OTHERWISE SPECIFIED DIMENSIONS ARE IN INCHES
TOLERANCES ARE DECIMALS

APPROVAL: *[Signature]* DATE: *[Date]*

DESIGN: *[Signature]* TITLE: **WIRING DIAGRAM-MTSU**

SAFETY: *[Signature]*

DES MGR: *[Signature]* CODE IDENT: **32274** SIZE: **D** DWRN NO: **966104-300**

MFG ENG: *[Signature]* SCALE: **NONE**

ISSUED: *[Signature]* DATE: *[Date]* DRAWING: **SH 1 OF 1**

966104-300

DRAWING 40 22

REVISION					
LTR	DESCRIPTION	OWN	DATE	APVD	DATE
A					
B	INCOEP ECO 16701	MD	8-1-88	SL	28
C	INCOEP ECO 17452	MD	5-9-12	SL	24
D	INCOEP ECO 17622	DMD	6/16/88	SL	24

3.5 X 15.5 AREA
REQD FOR 1/0
HOST CABLE

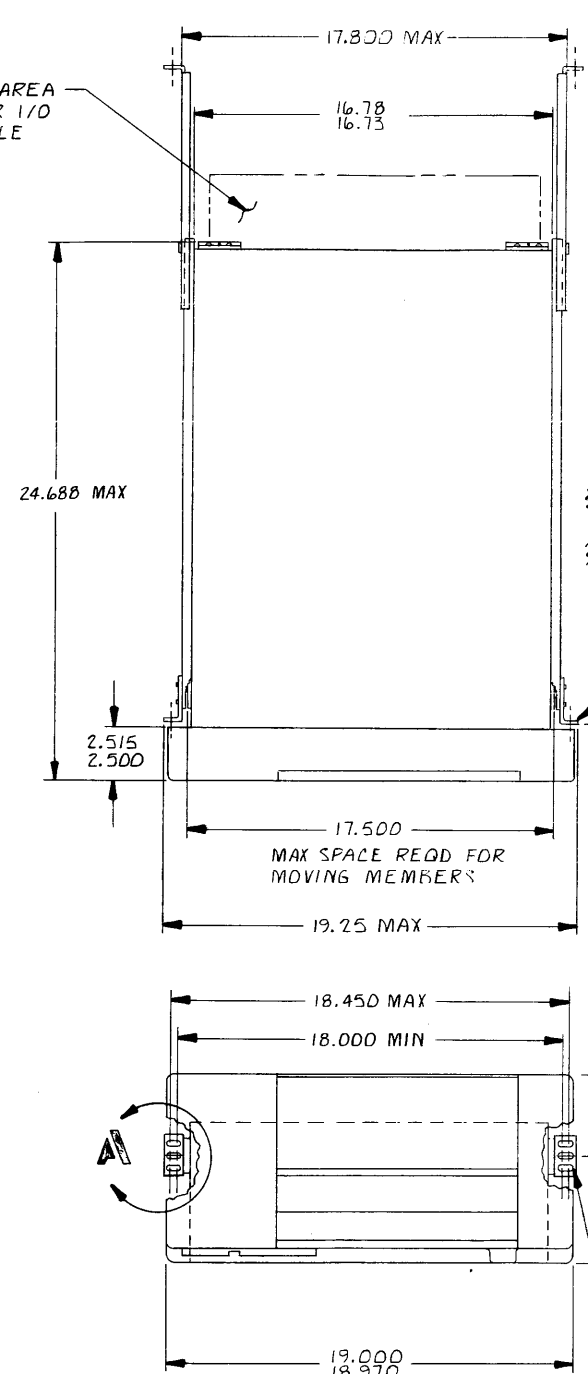

31.125 USING LONG ADJUSTABLE
21.750 REAR MTG BRACKET
22.250 USING SHORT ADJUSTABLE
21.625 REAR MTG BRACKET

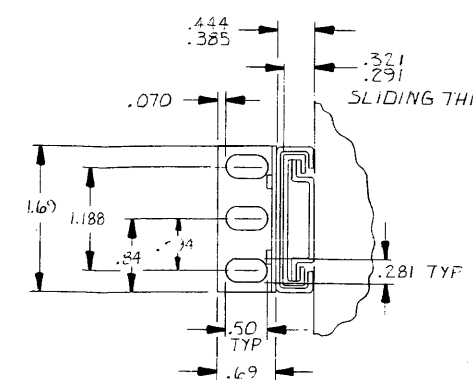
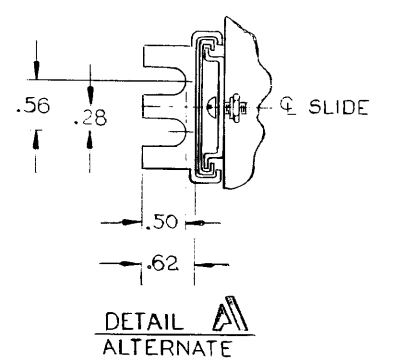

DETAIL A
(SEE ALT DETAIL A)

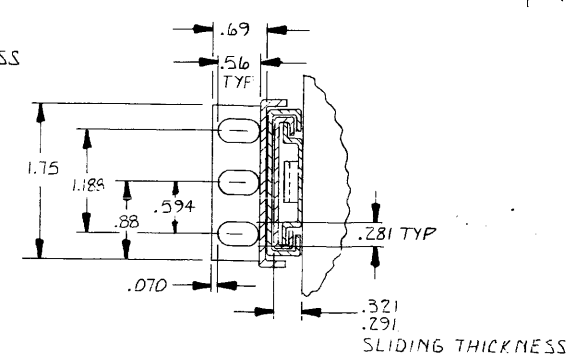

SECTION B-B
SCREWS & BAR NUT
OMITTED FOR CLARITY

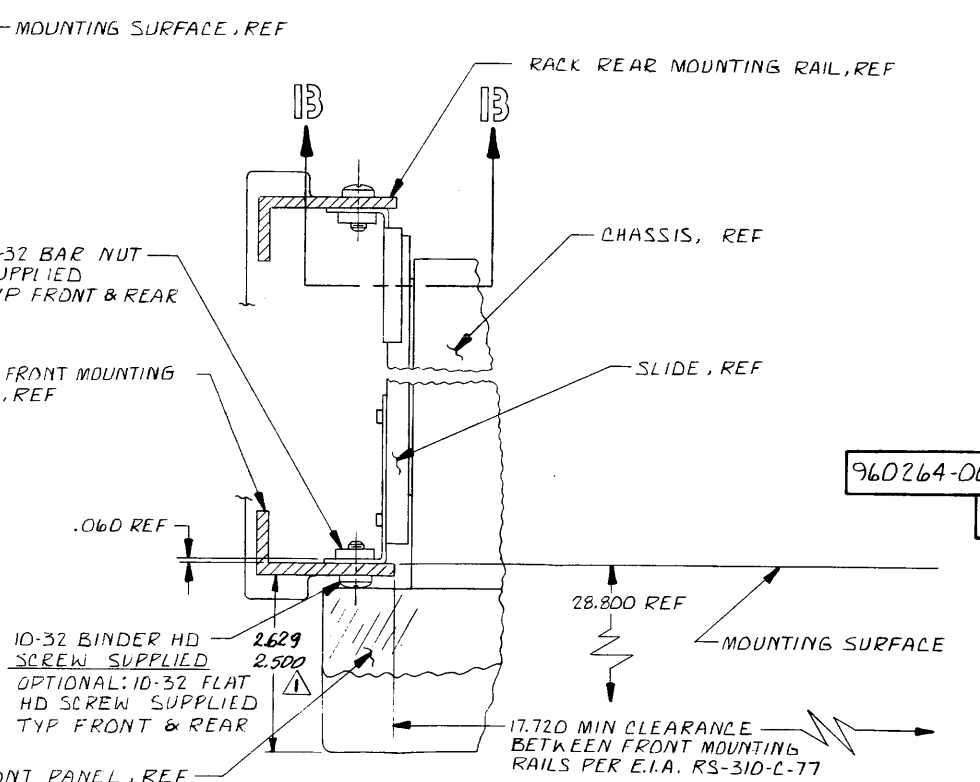
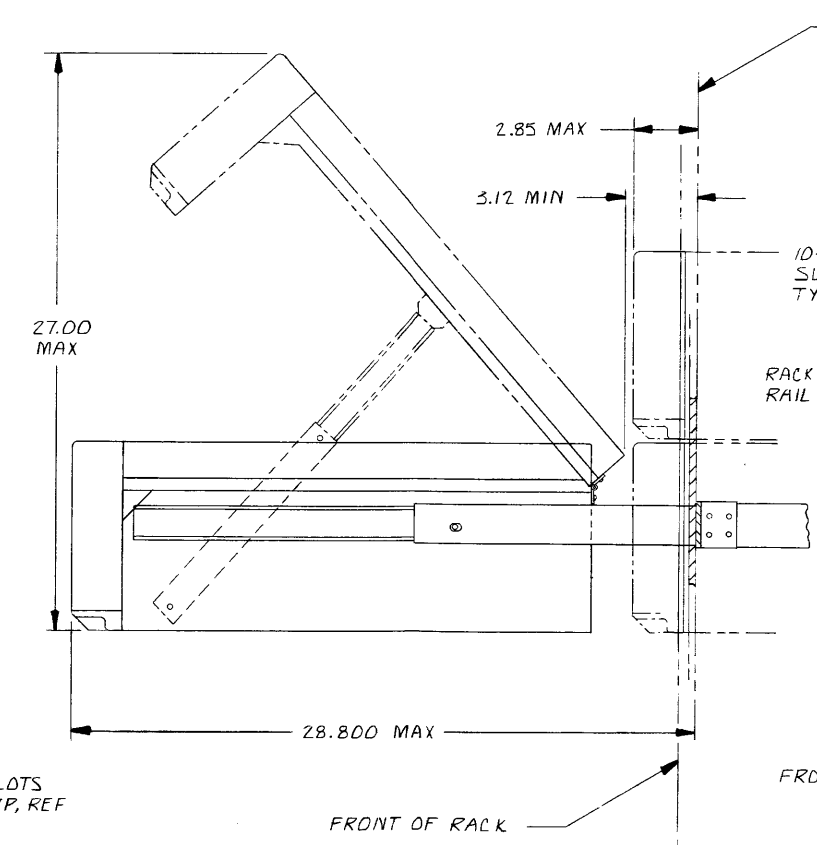

TYPICAL INSTALLATION
THE F880 WITH SLIDES MOUNTED
IS DESIGNED TO FIT INTO A
STANDARD E.I.A. RS-310-L-77
RACK

NOTE:
MOUNTING DIMENSIONS WILL VARY
FROM 2.629 WITH A BINDER HEAD SCREW
TO 2.500 WITH A FLUSH HEAD SCREW.

CHASSIS ASSY	DIM A
960566 - 001, -009 & -010	5.000 4.900
960566 - 002	3.972 3.872
960566 - 004	4.320 4.220

DRG	APPROVAL	DATE	OWN	DATE	APVD	DATE
MECH	MECH	3/11/83	MD	8-1-88	SL	28
ELEC	ELEC					
TEST	MFG					
PROD	MAIL					

UNLESS OTHERWISE SPECIFIED DIMENSIONS ARE IN INCHES
TOLERANCES ARE DECIMALS
XX = .03
XXX = .010
ANGLES ±
DO NOT SCALE DRAWING

TITLE
MTSU-RACK MOUNT, INTERFACE

CODE IDENT 32274
SIZE D
DWG NO 960264-000
REV 0

SCALE NONE
MOD
SH 1 OF 1

ALL INFORMATION CONTAINED IN OR DISCLOSED BY THIS DOCUMENT IS
CONSIDERED CONFIDENTIAL AND PROPRIETARY BY OTHER DATA PRODUCTS,
INC. BY ACCEPTING THIS MATERIAL, THE RECIPIENT AGREES THAT THIS
MATERIAL AND THE INFORMATION CONTAINED THEREIN IS HELD IN
CONFIDENCE AND IN TRUST AND WILL NOT BE USED, REPRODUCED IN
WHOLE OR IN PART NOR ITS CONTENTS REVEALED TO OTHERS EXCEPT
TO MEET THE PURPOSE FOR WHICH IT WAS DELIVERED. IT IS UNDERSTOOD
THAT NO RIGHT IS CONVEYED TO REPRODUCE OR BE REPRODUCED ANY
ITEM HEREIN DISCLOSED WITHOUT EXPRESS PERMISSION FROM
OTHER DATA PRODUCTS, INC.

REV D

960264-000
REV D

Index

A

additional sense 5-9, 7-21 – 7-23, 7-26
air filter 4-3
arbitration 2-15, 7-1 – 7-2
asynchronous 8-1
autoload 3-3
automatic speed control 7-12

B

bearing 6-32 – 6-33, 6-39 – 6-40
bell crank 6-14, 6-29 – 6-30
blower 5-9, 6-2, 6-4, 6-20
BOT 1-1, 3-2, 3-5, 4-2, 5-2, 5-4, 6-2, 6-9, 6-48, 7-8, 7-11, 7-16, 7-21, 7-23 – 7-24, 7-28, 7-34
BOT sensor 3-5, 5-4
buffered 7-4, 7-11 – 7-12, 7-14, 7-18, 7-34 – 7-35

C

configuration 2-1, 2-14 – 2-15
Control Switches 6-2, 6-5
Copy command 7-6 – 7-7, 7-20 – 7-22, 7-25, 7-35
cover retainer arm 1-3 – 1-4, 1-6 – 1-7

D

default 7-12 – 7-14
density 3-2, 7-12 – 7-13
diagnostic 3-2, 5-1 – 5-3, 5-9 – 5-11, 7-4, 7-17 – 7-18, 7-28 – 7-30
diagnostic function 7-30
Diagnostic Inquiry 5-10, 7-17 – 7-18, 7-30
diagnostic mode 3-2, 5-2 – 5-3
differential 2-9, 2-12 – 2-13, 6-2, 7-1
DIP switch 2-14 – 2-15
door lock 5-8, 6-7 – 6-8, 6-12
door lock circuit board 6-7

E

enclosure 1-2, 1-4, 1-7, 2-4 – 2-6, 8-2
EOT 4-2, 5-2, 5-6, 6-2, 6-9, 6-48, 6-50, 7-21, 7-23 – 7-25, 7-33 – 7-35
EOT sensor 5-6
Erase command 7-8
error code 5-1 – 5-2, 5-10 – 5-11
extended sense 5-10, 7-13, 7-18, 7-20 – 7-23, 7-33 – 7-35

F

file mark 5-3, 7-6, 7-12, 7-21 – 7-22, 7-24, 7-30, 7-33 – 7-34
file-protect 5-2, 5-7
file-protect sensor 6-2, 6-10
Freon TF 4-1
front panel door 2-1, 3-3 – 3-6, 5-2, 5-8
fuse 2-6 – 2-8, 6-2, 6-13

H

HI DEN 3-2, 3-5, 5-1, 5-5 – 5-9, 6-54 – 6-55
hub lock 6-14, 6-29
hub lock solenoid 5-8, 6-14, 6-29
hub-height adjustment tool 6-1, 6-48 – 6-50

I

indicator 3-1 – 3-3, 3-5 – 3-6, 5-1 – 5-2, 7-21, 7-23, 7-33
input air duct 6-15, 6-20
Inquiry command 7-9
installation 2-1, 2-4 – 2-6, 2-8, 2-16, 6-23
interlock 5-2, 6-1 – 6-2, 6-16, 6-44
Interlock Disable Procedure 5-2, 6-44
interlock disable tool 6-44, 6-53
interlock switch 6-16, 6-42, 6-44, 6-53

J

J1 6-18
J2 6-18
J3 6-18
J4 6-17 – 6-18
J5 6-17 – 6-18, 6-20
J6 6-20
J7 6-20
J8 6-20

L

LED 4-2, 5-1, 5-3 – 5-4, 5-6 – 5-11, 6-45, 6-53 – 6-55
left output air duct 6-17, 6-20, 6-39 – 6-41
level 0 diagnostics 5-10, 7-27
line filter 6-20
LOAD/REWIND 3-2 – 3-3, 5-1
Load/Unload command 7-10
loading tape 3-3

Loctite 6-1, 6-33, 6-40

Lubriplate 6-1, 6-7

M

main circuit board 2-4–2-5, 2-14–2-15, 5-10, 6-18, 6-20, 6-35, 6-46

maintenance 4-1

Manual Load 3-3

manual release switch 3-4, 3-6, 6-19

Manual Unload 3-6

Mode Select command 7-11, 7-13–7-14, 7-24, 7-34

Mode Sense command 7-13

motor filter 6-20, 6-30, 6-35

motor insulator 6-30, 6-35

O

off-line 3-2, 5-10, 7-6, 7-24, 7-29–7-30

ON-LINE 3-2, 3-6, 5-1, 5-6–5-8, 6-54–6-55, 7-11, 7-24

on-line 7-24

OPERATION 3-1–3-6

operator access 1-3, 3-3, 3-6, 6-44

options 2-14–2-15

oscilloscope 6-46

P

parameters 7-5–7-6, 7-11, 7-13, 7-25

part numbers 6-2

pawls 5-8

PIOs 5-4

power supply 1-2, 2-6–2-8

power supply circuit board 2-7, 6-20, 6-43

power supply housing 2-6–2-7, 6-4, 6-15, 6-20, 6-35, 6-40

power switch 2-6, 3-2–3-3, 3-5–3-6, 6-22, 6-24

power-up 2-15, 5-2, 5-10, 6-16, 7-26

power-up diagnostics 3-2

Q

quadrature 5-3–5-4

R

R136 6-45

rack latch 1-3–1-4, 2-3

rack mount 1-2, 8-2

Rack-Mounted 1-3–1-4

Read Block Limits command 7-15
Read command 7-14 – 7-16, 7-18, 7-28
Read Reverse command 7-16
read threshold adjustment 5-9, 6-18, 6-23, 6-45
read threshold potentiometer 6-45
read/write head 1-1 – 1-2, 3-5, 4-1, 6-23
Receive Diagnostic command 5-10, 7-17, 7-28, 7-30
Recover Buffered Data command 7-18 – 7-19
reference level tape 6-1, 6-45
Request Sense command 5-9 – 5-10, 7-20
Reserve Unit command 7-27 – 7-28
residue 7-16, 7-21, 7-34 – 7-35
retry 7-23, 7-34
Rewind command 7-28
right output air duct 6-3, 6-20, 6-24
roller guide 1 6-25, 6-40, 6-51
roller guide 2 6-26, 6-46, 6-51
roller guide 3 6-51
roller guide 4 6-51 – 6-52
roller guide 5 6-46, 6-52
rotor 6-3, 6-39 – 6-41, 6-53 – 6-54

S

safety pin 1-5 – 1-7
scratch tape 6-48, 6-50 – 6-51
SCSI bus 1-1, 2-16 – 3-1, 3-3, 3-6, 7-10
SCSI cable 2-5, 2-16
SCSI ID 2-14, 7-6
SCSI ID Switch 2-14
Send Diagnostic command 5-9 – 5-10, 7-17, 7-28 – 7-30
sense key 7-21 – 7-23, 7-25, 7-33 – 7-35
service access 1-3 – 1-4, 2-1, 2-4, 2-6, 6-1
Service Aid 11 5-3, 6-33
Service Aid 12 5-3
Service Aid 13 5-3
Service Aid 14 5-3
Service Aid 21 5-4, 5-9, 6-45
Service Aid 22 5-4, 5-9
Service Aid 23 5-6, 5-9, 6-46 – 6-48, 6-50 – 6-51
Service Aid 24 5-6 – 5-8, 6-53 – 6-54
Service Aid 31 5-7, 6-10, 6-37 – 6-38

Service Aid 32 5-8, 6-8, 6-12, 6-14, 6-29
Service Aid 33 5-8
Service Aid 34 5-9
servo 5-2–5-4
shims 6-25–6-27, 6-32–6-33, 6-40, 6-51–6-52
single-ended 2-8–2-11, 6-2, 7-1
skew 6-46
skew adjustment 6-23, 6-46–6-47, 6-52
skew tape 6-1, 6-46–6-47
Space command 7-30–7-31
special tools 6-1
Specifications 8-1–8-3
stator 6-3, 6-39–6-41
status byte 7-3–7-4, 7-20
supply hub 1-1, 3-3–3-4, 3-6, 5-2, 5-7–5-8, 6-28–6-30, 6-48
Supply Hub Adjustment 6-28, 6-48, 6-51
supply motor 6-29–6-30, 6-48
supply reel 3-6, 5-2, 6-48
support arm 1-5–1-7

T

table-top 1-2, 2-4, 8-2
tachometer 2-1, 3-4, 4-1, 5-3–5-4, 6-3, 6-32–6-34, 6-49–6-50
Take-Up 6-3, 6-34–6-36, 6-49, 6-52
take-up hub 1-1, 2-1, 3-4, 4-1, 6-34–6-35, 6-49–6-50
take-up motor 6-20, 6-34–6-35, 6-50
Tape Alignment Adjustment 6-23, 6-25–6-27, 6-41, 6-51
tape cleaner 4-1
Tape Loaded Diagnostics 5-9
tape path 1-2–1-4, 1-6–1-7, 2-1, 4-1
Tape Unloaded Diagnostics 5-3
tape-in-path receiver 6-37
tape-in-path sensor 5-2, 5-7–5-8, 6-37
tape-in-path transmitter 6-38
tension arm 1-1–1-2, 5-2, 5-7, 5-9, 6-39–6-41, 6-53–6-55
Tension Arm Output Adjustment 6-41, 6-53, 6-56
tension arm output voltage 5-6
Tension Arm Spring Adjustment 6-55–6-56
termination 2-8–2-9, 2-14, 7-1
terminator 2-8, 2-16, 7-1
Test Unit Ready command 2-15, 7-31–7-32

tie-wraps 6-24, 6-43
top cover 1-2–1-7, 2-1, 3-1–3-2, 3-5, 6-42
torque seal 6-1, 6-47, 6-56
transformer 6-3, 6-43
troubleshooting 5-1, 5-4, 5-10, 6-44
twisted-pair 2-8–2-9

U

U2C 2-14–2-15, 5-10
U4A 2-15
unbuffered 7-11–7-12, 7-14, 7-34–7-35
underrun 7-12, 7-27
UNLOAD 3-1–3-3, 3-5–3-6, 5-1–5-3, 5-5, 5-7–5-9, 6-45, 6-47–6-48, 6-50, 6-54–6-55, 7-4, 7-10
unloading tape 3-6
UNPACKING 2-1
unshielded 2-8, 2-10, 7-1

V

Verify command 7-26, 7-32
voltage selection 2-6–2-7
Voltage-Select 2-7, 6-3

W

wavewasher 6-32–6-33, 6-40
Write command 5-1–5-2, 7-8, 7-16, 7-34–7-35
Write File Mark command 7-35–7-36
write-enable ring 3-2–3-4, 5-7, 6-45–6-46
write-enabled 5-7, 5-9, 7-14
write-protected 5-1–5-2, 7-14, 7-24, 7-35
WRTE N/TEST 3-2

cipher®

P.O. Box 85170
San Diego, California 92138