

**PRODUCT SPECIFICATION
FOR
WREN III HH SCSI
MODEL 94211**

COPYRIGHT © 1988
by CONTROL DATA CORPORATION
ALL RIGHTS RESERVED

Printed in the United States of America

This publication may contain application, high technology, or product specification data, or any combination thereof, is considered advance technical information by the producer, and is subject to change without prior notice.

PRODUCT SPECIFICATION
FOR
WREN III HH SCSI
MODEL 94211

THIS SPECIFICATION OUTLINES THE PRODUCT
CHARACTERISTICS AND PERFORMANCE CRITERIA
OF THE 94211 WREN III HH SCSI.

SPECIFIC MODEL AVAILABILITY CAN BE CONFIRMED
BY YOUR CDC OEM SALES REPRESENTATIVE.

SUMMARY

The CDC WRENTM Peripheral family is composed of the following members. For specific information on each member, refer to the appropriate documents.

NAME	MODEL NUMBER *	PRODUCT SPECIFICATION	INTERFACE	CAPACITY (MEGABYTES)
WREN II	94155-XX	77715909	CDC 506 (ST506 COMP.)	48, 57, 67, 77 or 86
WREN II	94156-XX	77738019	ESDI	46, 67 or 86
WREN II	94151-YY	77738208	SCSI (SASITM Subset)	25 to 80
WREN II HH	94205-XX	77738161	CDC 506 (ST506 COMP.)	30, 41 or 51
WREN III	94166-XXX	77738212	ESDI	101, 141 or 182
WREN III	94161-YY(Y)	77738270	SCSI **	86, 121 or 155 (512 Byte)
WREN III HH	94211-YY(Y)	77765250	SCSI **	91 (512 Byte)
WREN III HH	94216-XXX	77765276	ESDI	106
WREN-IV	94171-YY(Y)	77738386	SCSI **	307 (512 Byte)

* XX(X) denotes unformatted drive capacity in megabytes. For example, Model number 94166-182 is a WREN III with ESDI Interface and an unformatted capacity of 182 megabytes.

YY(Y) denotes formatted drive capacity.

** These drives allow the user to reformat using any integer data block size between 256 and 2048 bytes. At the factory, drives are formatted with 512 byte data block size, with capacity dependent on number of data heads.

TABLE OF CONTENTS

1.0 SCOPE..... 8

2.0 APPLICABLE DOCUMENTS..... 8

 2.1 STANDARDS..... 8

 2.2 DOCUMENTATION..... 10

3.0 GENERAL DESCRIPTION..... 10

4.0 FEATURES..... 13

 4.1 STANDARD FEATURES..... 13

 4.2 OPTIONS (Factory Installed)..... 14

 4.3 OPTIONAL ACCESSORIES (User Installed)..... 14

5.0 PERFORMANCE CHARACTERISTICS..... 15

 5.1 INTERNAL DRIVE CHARACTERISTICS (Transparent to User)..... 15

 5.2 SCSI DRIVE SEEK, READ AND WRITE PERFORMANCE CHARACTERISTICS (Visible to User)..... 15

 5.2.1 Seek Command Execution Time..... 15

 5.2.2 Format Drive Command Execution Time.... 16

 5.2.3 Read Data Command Execution Time..... 16

 5.2.4 Write Data Command Execution Time..... 16

 5.3 GENERALIZED PERFORMANCE CHARACTERISTICS..... 17

 5.4 START/STOP TIME..... 17

6.0 RELIABILITY SPECIFICATIONS..... 19

 6.1 ERROR RATES..... 19

 6.1.1 Read Errors..... 19

 6.1.2 Environmental Interference..... 20

 6.1.3 Write Errors..... 20

 6.1.4 Seek Errors..... 21

 6.2 RELIABILITY AND SERVICE..... 21

 6.2.1 Mean Time Between Failure..... 21

 6.2.2 Preventive Maintenance..... 21

 6.2.3 Service Life..... 21

 6.2.4 Service Philosophy..... 22

 6.2.5 Installation..... 22

 6.2.6 Service Tools..... 22

7.0 PHYSICAL/ELECTRICAL SPECIFICATIONS..... 23

 7.1 AC POWER REQUIREMENTS..... 23

 7.2 DC POWER REQUIREMENTS..... 23

 7.2.1 Power Sequencing..... 24

 7.2.2 12 V Current Profile..... 24

 7.2.3 System Grounds..... 25

TABLE OF CONTENTS (continued)

7.3 HEAT/POWER DISSIPATION..... 26

7.4 ENVIRONMENTAL LIMITS..... 26

 7.4.1 Temperature..... 26

 7.4.2 Relative Humidity..... 27

 7.4.3 Effective Altitude (Sea Level Ref)..... 27

 7.4.4 Shock and Vibration..... 27

 7.4.5 Air Cleanliness..... 32

7.5 MECHANICAL SPECIFICATIONS..... 33

 7.5.1 Drive Orientation..... 34

 7.5.2 Cooling..... 34

8.0 MEDIA CHARACTERISTICS..... 34

 8.1 MEDIA DESCRIPTION..... 34

9.0 DEFECT AND ERROR MANAGEMENT..... 34

 9.1 WREN III HH SCSI INTERNAL DEFECTS/ERRORS..... 35

 9.2 SCSI SYSTEMS ERROR CONSIDERATIONS..... 35

10.0 INTERFACE REQUIREMENTS AND OPTIONS..... 36

 10.1 GENERAL DESCRIPTION..... 36

 10.2 DC CABLE CONNECTOR..... 37

 10.3 PHYSICAL CHARACTERISTICS..... 38

 10.3.1 Physical Description..... 38

 10.3.2 Cable Requirements..... 39

 10.3.3 Connector Requirements..... 39

 10.3.4 Electrical Description..... 41

11.0 SCSI BUS..... 44

 11.1 SCSI BUS SIGNALS..... 44

 11.1.1 Signal Values..... 46

 11.1.2 OR-Tied Signals..... 46

 11.1.3 Signal Sources..... 47

 11.2 SCSI BUS TIMING..... 47

12.0 LOGICAL CHARACTERISTICS..... 50

 12.1 SCSI BUS PHASES..... 50

 12.1.1 BUS Free Phase..... 50

 12.1.2 Arbitration Phase..... 50

 12.1.3 Selection Phase..... 50

 12.1.4 Reselection Phase..... 51

 12.1.5 Information Transfer Phase..... 51

 12.1.6 COMMAND Phase..... 51

 12.1.7 DATA Phase..... 51

 12.1.8 STATUS Phase..... 52

 12.1.9 MESSAGE Phase..... 52

 12.1.10 Signal Restrictions Between Phases..... 52

TABLE OF CONTENTS (continued)

12.2	SCSI BUS CONDITIONS.....	52
12.2.1	ATTENTION Condition.....	52
12.2.2	RESET Condition.....	52
12.3	SCSI BUS PHASE SEQUENCES.....	52
12.3.1	Nonarbitrating System.....	52
12.3.2	Arbitrating Systems.....	52
12.3.3	All Systems.....	53
12.4	SCSI POINTERS.....	53
12.5	MESSAGE SYSTEM SPECIFICATION.....	53
12.5.1	Message Protocol.....	53
12.5.2	Messages.....	53
12.5.3	Extended Messages.....	53
12.5.4	Synchronous Data Transfer Request.....	53
13.0	SCSI COMMANDS.....	54
13.1	COMMAND IMPLEMENTATION REQUIREMENTS.....	54
13.1.1	Reserved.....	54
13.1.2	Operation Code Type.....	54
13.1.3	Unit Attention Condition.....	54
13.2	COMMAND DESCRIPTOR BLOCK (CDB).....	54
13.2.1	Operation Code.....	54
13.2.2	Logical Unit Number (LUN).....	56
13.2.3	Logical Block Address.....	56
13.2.4	Relative Address Bit.....	56
13.2.5	Transfer Length.....	56
13.2.6	Control Byte.....	56
13.3	COMMAND EXAMPLES.....	56
13.3.1	Single Command Example.....	56
13.3.2	Disconnect Example.....	56
13.4	TIMING EXAMPLES.....	56
13.5	WREN III SCSI TIMING.....	57
14.0	COMMAND DESCRIPTIONS.....	58
14.1	COMMAND DESCRIPTIONS FOR ALL DEVICE TYPES.....	58
14.1.1	Group 0 Commands for All Device Types..	58
14.1.1.1	Test Unit Ready.....	59
14.1.1.2	Request Sense Command.....	60
14.1.1.3	Inquiry Command.....	66
14.1.1.4	Copy Command.....	68
14.1.1.5	Receive Diag. Results Command	69
14.1.1.6	Send Diagnostic Command.....	71
14.1.2	Group 1 Commands for All Device Types..	71
14.1.2.1	Compare Command.....	71
14.1.2.2	Copy and Verify Command.....	71
14.1.2.3	Write Data Buffer Command....	72
14.1.2.4	Read Data Buffer Command.....	74
14.1.3	Group 2 through 5 Commands for	
	All Device Types.....	75
14.1.4	Group 6 Commands for All Device Types..	75
14.1.5	Group 7 Commands for All Device Types..	75

TABLE OF CONTENTS (continued)

14.2	COMMAND DESCRIPTIONS FOR DIRECT ACCESS DEVICES...	76
14.2.1	Group 0 Commands for Direct Access Devices.....	76
14.2.1.1	Rezero Unit Command.....	77
14.2.1.2	Format Unit Command.....	77
14.2.1.3	Reassign Blocks Command.....	83
14.2.1.4	Read Command.....	84
14.2.1.5	Write Command.....	86
14.2.1.6	Seek Command.....	87
14.2.1.7	Mode Select Command.....	88
14.2.1.8	Reserve Command.....	91
14.2.1.9	Release Command.....	92
14.2.1.10	Mode Sense Command.....	93
14.2.1.11	Start/Stop Unit Command.....	103
14.2.1.12	Prevent/Allow Medium Removal Command.....	104
14.2.2	Group 1 Command for Direct Access Devices.....	104
14.2.2.1	Read Capacity Command.....	105
14.2.2.2	Read Extended Command.....	107
14.2.2.3	Write Extended Command.....	108
14.2.2.4	Seek Extended Command.....	109
14.2.2.5	Write and Verify Command.....	110
14.2.2.6	Verify Command.....	111
14.2.2.7	Search Data Commands.....	112
14.2.2.8	Set Limits Command.....	112
14.2.2.9	Read Defect Data Command.....	112
14.2.2.10	Read Long Command.....	115
14.2.2.11	Write Long Command.....	117
15.0	STATUS.....	119
16.0	ERROR RECOVERY PHILOSOPHY.....	119
16.1	SEEK ERRORS (09 or 15 HEX ERROR CODE).....	120
16.2	DATA FIELD WRITE FAULT (03 HEX ERROR CODE).....	121
16.3	SYNC BYTE ERROR (12 HEX ERROR CODE).....	121
16.4	DATA FIELD ECC ERROR (11 Hex or 18 Hex Error Code).....	121
16.5	ALTERNATE SECTOR PROCESSING.....	122
16.6	AUTOMATIC READ REALLOCATION.....	122
16.7	AUTOMATIC WRITE REALLOCATION.....	122
17.0	OPTIONS.....	123
17.1	FRONT PANEL.....	123
17.2	AC/DC GROUND SEPARATION.....	123
17.3	SINGLE UNIT SHIPPING PACK.....	123
17.4	DRIVE TERMINATION.....	123
18.0	ACCESSORIES.....	123
18.1	FRONT PANEL KIT.....	123
18.2	OEM MANUAL.....	124

1.0 SCOPE

This specification describes the Control Data Corporation Model 94211 WREN™ III Half Height (HH) Disk Drive. This high capacity, high performance, member of the 5 1/4 inch WREN rigid disk family incorporates the Half Height WREN III HDA (Head/Disk Assembly) with an embedded SCSI controller. Performance information is given in Section 5. The Model 94211 interface is defined for functional compatibility to the mandatory subset of the CDC SCSI Interface Specification (which is compatible with the ANSI SCSI standard). The Model 94211 WREN is classified as an "Intelligent" peripheral. The WREN III HH provides Level 2 conformance (highest level) with the ANSI SCSI standard. Details of SCSI options are provided in Section 10-16.

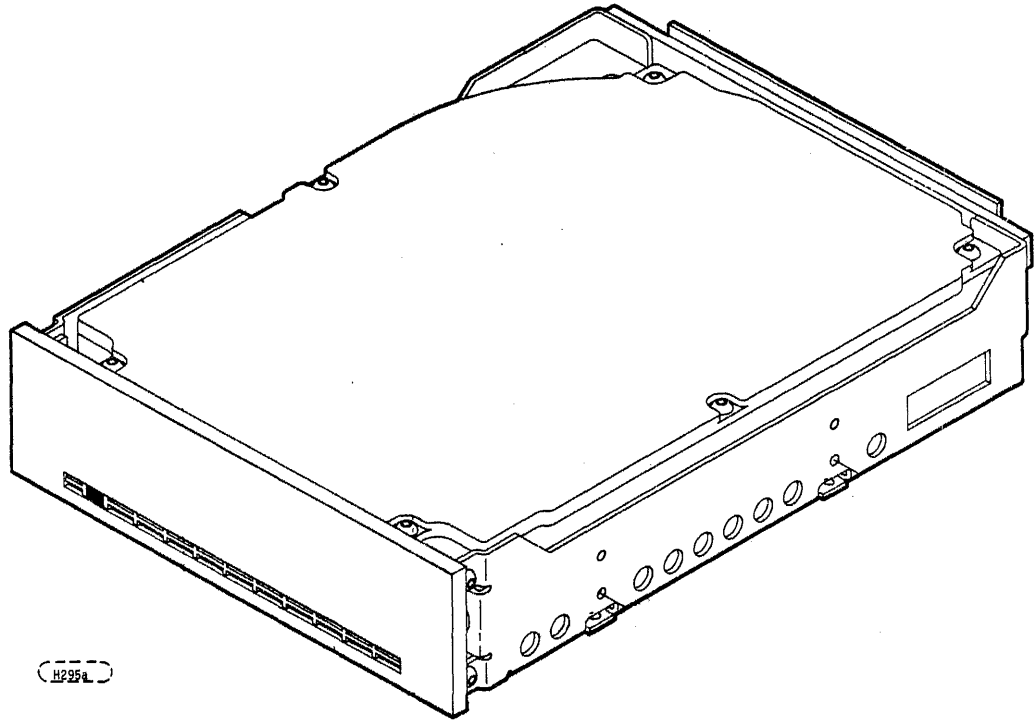

FIGURE 1. 94211 WREN III HH

2.0 APPLICABLE DOCUMENTS

2.1 STANDARDS

The WREN III HH has been developed as a system peripheral to the highest standards of design and construction. The WREN III HH depends upon its host equipment to provide adequate power and environment in order to achieve optimum performance and compliance with applicable industry and governmental regulations. Special attention must be given in the areas of safety, power distribution, shielding, audible noise control, and temperature regulation.

2.1 (continued)

The WREN III HH complies with CDC standards as noted in the appropriate sections of this specification.

The WREN III HH IS A UL Recognized component per UL 478 and a CSA Certified component per CSA C22.2 No. 154-M1983. It also meets the requirements of DIN IEC 380/VDE 0806/8.81.

The WREN III HH, as delivered, is designed for system integration before use. It is supplied as a Class A Computing Device per the FCC Rules and Regulations, Part 15, Subpart J governing EMI of computing devices.

CAUTION

To avoid potential repair problems, observe the following precautions:

- Labels must not be put over the breather holes on the top of the drive.
- If a label has been placed over the breather holes, do not poke holes thorough the label, as the filter underneath is certain to be damaged, allowing contamination to enter. REMOVE THE LABEL. Do not use solvents to remove the adhesive residue. Small amounts of solvent may migrate down the breather holes and contaminate the disk.
- CDC/MPI factory installed labels must not be removed from the drive or covered with additional labels, as they contain information required when repairing.
- DC power should not be switched on to the drive by plugging an electrically "live" DC source cable into the drive power connector. This practice adversely affects the reliability of the connector contacts.

2.2 DOCUMENTATION

77765253 OEM Manual (WREN III HH SCSI)
64721700 CDC Small Computer System Interface (SCSI)
ANSI Small Computer System Interface (SCSI): Document
Number BSRX3.131-198X (X3T9/84-40 Rev. 1B) (X3T9.2/82-2
Rev. 17B).

3.0 GENERAL DESCRIPTION

The WREN III HH is a member of a family of low cost, high performance, highly reliable, random access storage devices designed to meet the needs of the OEM marketplace.

The WREN III HH is designed to record and recover data on three, 5-1/4 inch (130 mm) fixed disks.

The Model 94211 WREN III HH supports the Small Computer System Interface (SCSI) as described in Control Data's SCSI Specification (64721700). The WREN III HH Product Specification was created to be used in conjunction with the Control Data SCSI industry standard interface specification. The information contained in these two documents defines the product performance characteristics and the interface characteristics of the Model 94211 WREN III HH.

The Model 94211 WREN III HH SCSI interface supports multiple initiators, disconnect/reconnect, self configuring host software and automatic features that relieve the host from the necessity of knowing the physical characteristics of the targets (logical block addressing is used).

3.0 (continued)

The Head/Disk Assembly (HDA) is environmentally sealed at the factory. Air is recirculated within the HDA through a nonreplaceable filter to maintain a contamination free disk/actuator environment.

Refer to Figure 2 for an exploded view of the WREN III HH. NEVER disassemble the WREN HDA. This exploded view is for information only. Servicing items in the sealed environmental enclosure (heads, media, actuator, etc.) requires special facilities. The printed circuit boards and hardware external to the sealed area may be replaced without special facilities.

The WREN III HH uses a dedicated landing zone at the innermost radius of the media thus eliminating the possibility of destroying or degrading data by landing in the data zone.

The WREN III HH incorporates an automatic shipping lock which prevents potential damage to the heads and disks caused by movement during shipping and handling. The shipping lock is automatically disengaged when power is applied to the drive.

The WREN III HH decodes Track 0 location from the dedicated servo surface thereby eliminating mechanical transducer adjustments and related reliability concerns.

The WREN III HH uses a high performance actuator assembly consisting of a low inertia, balanced, patented, straight arm design which provides excellent performance with minimum power dissipation.

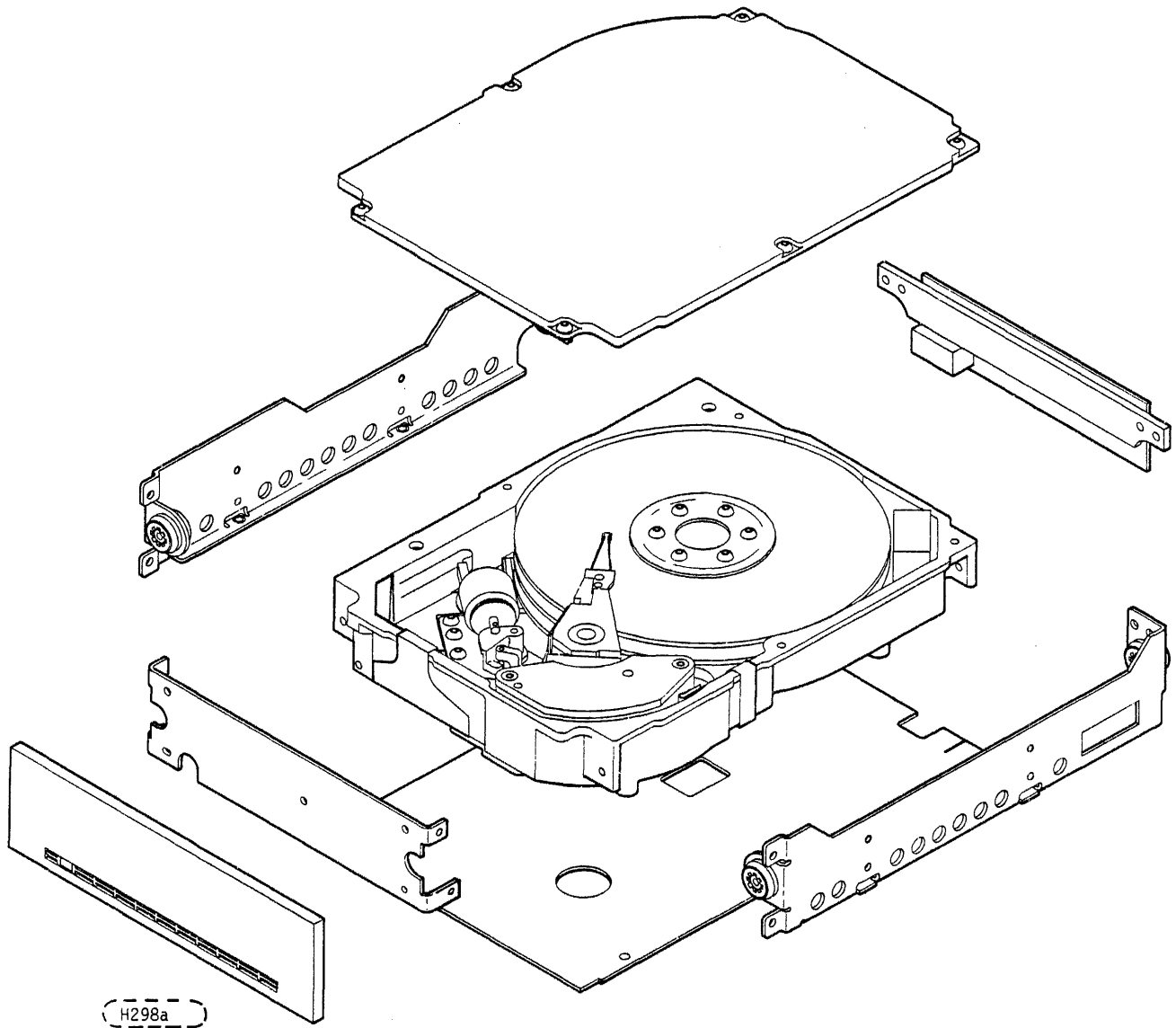

FIGURE 2. MODEL 94211 WREN III HH

4.0 FEATURES

4.1 STANDARD FEATURES

The Model 94211 WREN III HH has the following standard features:

- Integrated SCSI Controller
- Single ended SCSI drivers and receivers
- Asynchronous SCSI bus data transfer protocol
- 8K byte data buffer (32K optional)
- Selectable data block sizes from 256 to 2048 bytes in one byte increments.*
- Flawed sector reallocation at format time
- Reallocation of defects on command (Post Format)
- Automatic reallocation of defective sectors during reads and writes
- Five spare reallocation sectors per cylinder
- Error Correction
- 1:1 sector interleave
- Sealed head, disk and actuator chamber
- No preventive maintenance required
- No adjustments required
- LSI circuitry for high reliability
- Low audible noise for office environment
- Vertical or horizontal mounting
- Low power consumption
- Balanced low mass rotary voice coil actuator
- Automatic shipping lock
- Easy access terminators
- Integral HDA isolation mounts
- Dedicated head landing zone
- Dynamic spindle braking
- Automatic retries on seek or data read errors (can be disabled)
- Command Queing of up to One Command per initiator.
- Automatic single track seek error correction capability.

* Units are formatted at the factory with 512 byte data blocks, giving a capacity (for 5 data heads) of 91.5 MB. However, the user can reformat the drives using any integral data block size between 256 and 2048 bytes. Drive capacity varies from the 91 MB if other than 512 data block size is used.

4.2 OPTIONS (FACTORY INSTALLED)

The following options are incorporated at the time of production and may be specified for delivery. See Section 17.0.

- Front panel - See Figure 2
- Single Unit shipping pack
- OEM Manual
- SCSI Interface Terminating Resistors

4.3 OPTIONAL ACCESSORIES (USER INSTALLED)

The following accessories are available. All kits may be installed in the field. See Section 18.0.

- Front Panel Kit - See Figure 2
- Single Unit shipping pack kit
- OEM Manual

5.0 PERFORMANCE CHARACTERISTICS

5.1 INTERNAL DRIVE CHARACTERISTICS (Transparent to User)

Data Capacity Parameters (unformatted)

Bytes/Track	20,880 Bytes
Bytes/Surface	21,301,120 Bytes
Tracks/Surface	1024 Tracks
Tracks/Inch	960 TPI
NOTE: User Accessible Tracks	1022 Max
Bits/Inch	19,058 BPI
Read/Write Heads	5 Data , 1 Servo
Recording Mode	2,7
Internal Data Transfer Rate	10 Mbits/sec
Disk Rotational Speed	3597 \pm 0.5% r/min
Average Seek Time	18 ms Typical

5.2 SCSI SEEK, READ AND WRITE PERFORMANCE CHARACTERISTICS (Visible to User)

Refer also to Table 5e for additional timing details. (see Section 13).

Notes are provided on Page 18 of this document.

5.2.1 Seek Command Execution Time

	Including Controller Overhead (Without <u>Disconnect [1] [4]</u>)	Not Including Controller Overhead
Average - Maximum	23.0 ms [2]	20 ms [2]
Typical	20.0 ms [3]	18.0 ms [3]
Single Track - Maximum	9 ms [2]	6 ms [2]
Typical	6 ms [3]	4 ms [3]
Full Stroke - Maximum	43 ms [2]	40 ms [2]
Typical	37 ms [3]	35 ms [3]

5.2.2 Format Drive Command Execution Time [1]

Maximum 8 minutes

5.2.3 Read Data Command Execution Time [4] (512 Bytes Sector Size and without disconnect). Latency time is included.

- a. From CDB reception to the WREN III HH request for the first data byte to be transferred to the Host
 - 1. Typical (Zero Stroke Seek) 11 ms [3]
 - 2. Typical (Average Seek) 29 ms [3]
 - 3. Maximum (Full Stroke Seek) 63 ms [2]
- b. Single Sector Read and Transfer of data to Host (time from receipt of last byte of the CDB to the request for a status byte transfer to Host) assuming a 1:1 interleave [8].
 - 1. Typical (Zero Stroke Seek) 12 ms [3]
 - 2. Typical (Average Seek) 30 ms [3]
 - 3. Maximum (Full Stroke Seek) 64 ms [2]

5.2.4 Write Data Command Execution Time [4].

(512 Byte Sector Size and without disconnect) Latency time is included.

- a. From CDB reception to the request for the first byte of write data from the Host.
 - 1. Typical 0.5 ms
 - 2. Maximum 0.7 ms
- b. Single Sector Write [8] [7]

(Measured from receipt of the last byte of the CDB to the request for a completion status transfer to the Host)

 - 1. Typical (Zero Stroke Seek) 11 ms [3]
 - 2. Typical (Average Seek) 29 ms [3]
 - 3. Maximum (Full Stroke Seek) 63 ms [2]

5.3 GENERALIZED PERFORMANCE CHARACTERISTICS

See Page 18 for Notes.

Minimum Sector Interleave	1 to 1
Instantaneous SCSI Interface Data Transfer Rate	1.25 MBytes/Sec (max)
Maximum SCSI Interface sustained Data Transfer Rate (512 Byte Sector)	<u>1.07 MBytes/Sec</u>
(Interleave factor equal to or greater than 1) [5], [6] & [9]	Interleave Factor
Sector Sizes	256 user data blocks (64 sectors) 512 user data blocks (35 sectors) 1024 user data blocks (18 sectors) Variable (256 to 2048)
Read/Write consecutive sectors on a track	YES
Max Host transfer rate (Asynchronous)	1.25 Mbytes/sec
Flaw reallocation performance impact (For flaws reallocated at Format Time)	Negligible (typically 1 sector time)
Flaw reallocation performance impact (For flaws reallocated after format time)	1 revolution (typical)
Overhead time for head switch	1 sector time
Overhead time for one track cylinder switch	1/2 revolution
Avg rotational latency	8.33 msec

5.4 START/STOP TIME

After DC power has been applied to the WREN III HH the Unit will become ready within 30 seconds if the Motor Start Option is disabled (i.e. the motor starts as soon as the power has been applied). During this time the internal controller will not respond to the SCSI interface until the drive has loaded the heads and positioned them to track zero. Stop time will be less than 30 seconds from removal of DC power.

If the Motor Start Option is enabled the internal controller will respond to the SCSI interface 3 seconds

5.4 (continued)

after DC power has been applied to the unit. After the Motor Start Command has been received the Unit will become ready for normal operations within 28 seconds.

There is no power control switch on the drive.

NOTES for Sections 5.2 and 5.3

- [1] Execution time measured from drive receipt of the last Byte of the Command Descriptor Block (CDB) to the request for a Status Byte Transfer to the Initiator (excluding connect/disconnect).
- [2] Maximum times are specified over the worst case conditions of temperature, voltage margins and drive orientation. When comparing specified seek times, care should be taken to distinguish between typical seek times and maximum seek times. The best comparison is obtained by system benchmark tests conducted under identical conditions.
- [3] Typical Seek values are measured under nominal conditions of temperature, voltage, and horizontal orientation as measured on a representative sample of WREN III HHs.
- [4] Assumes no errors and assumes that the sector has not been relocated.
- [5] Rate measured from the start of the first sector transfer with the Host and assumes at least one head change, but no cylinder change and less than 256 sectors transferred.
- [6] Assumes an instantaneous data transfer rate between the WREN III HH and the Initiator of at least 1.25 MBytes per second divided by the Interleave factor.
- [7] Assumes that the Initiator immediately begins sending Write Data to the WREN III HH when requested.
- [8] Command execution requires a data transfer phase (Data To/From the disk media). Assumes the initiator is instantly ready to send/receive the Data when the WREN III HH generates first request for a data byte transfer, and assumes an average data transfer rate between the WREN III HH and the Initiator of 1.25 MBytes/Second.
- [9] The Initiator must transfer data at 1.25 Mbytes/sec in order to obtain a 1.0 Mbytes/sec sustained Data transfer rate with a 1 to 1 interleave.

6.0 RELIABILITY SPECIFICATIONS

The following reliability specifications assume correct host/drive operational interface, including all interface timings, power supply voltages, and environmental requirements.

Read Error Rates [1]	
Soft Read Errors (Recoverable)	Less than 1 in 10^{10} bits transferred
Hard Read Errors (Unrecoverable)	Less than 1 in 10^{12} bits transferred
Seek Errors	Less than 1 in 10^6 seeks
MTBF	40,000 hours
Service Life	5 years or 30,000 hours
Preventive Maintenance	None required

NOTES:

[1] Error rates are specified with automatic retries enabled and data correction via ECC features disabled to permit direct observation of uncorrected performance. During WREN III HH drive operation these features should be enabled (see section 16 and Section 6.1).

6.1 ERROR RATES

The error rates stated in this specification assume the following:

- a. WREN III HH is operated per this specification using DC Power as defined in this specification (see section 7.2).
- b. The WREN III HH has been formatted via the SCSI FORMAT commands.
- c. Errors caused by media defects or host system failures are excluded from error rate computations. Refer to paragraph 8.0, Media Characteristics.

6.1.1 Read Errors

Before determination or measurement of read error rates:

- a. The data which is to be used for a measurement of read error rates must be verified as being written correctly on the media.
- b. All media defect induced errors must be excluded from error rate calculations.

6.1.2 Environmental Interference

When evaluating systems operation under conditions of Electromagnetic Interference (EMI), the performance of the WREN III HH within the system shall be considered acceptable if the WREN III HH does not generate an unrecoverable condition.

An unrecoverable error, or condition, is defined as one which:

1. Is not detected and corrected by the WREN III HH itself; or
2. Is not capable of being detected from the error or fault status provided through the WREN III HH/system interface; or
3. Is not capable of being recovered by normal WREN III HH or system recovery procedures without requiring operator intervention.

6.1.3 Write Errors

Write errors can occur as a result of the following: media defects, environmental interference, or equipment malfunction. Therefore, write errors are not predictable as a function of the number of bits passed.

If an unrecoverable write error occurs because of an equipment malfunction in the WREN III HH, the error is classified as a failure affecting MTBF. Unrecoverable write errors are those which cannot be corrected within two attempts at writing the record with a read verify after each attempt, (excluding media defects).

6.1.4 Seek Errors

A seek error is defined as a failure of the WREN III HH to position the heads to the addressed track. There shall be no more than one recoverable seek error in 10^6 physical seek operations. A recoverable seek error (with the WREN III HH automatic retries feature disabled) is a positioning error which can be corrected by the host issuing a Rezero Unit command and then reseeking to the addressed track. Unrecoverable seek errors are classified as failures for MTBF calculations.

6.2 RELIABILITY AND SERVICE

6.2.1 Mean Time Between Failure

The Mean Time Between Failure (MTBF) shall exceed 40,000 hours for the WREN III HH. MTBF is defined as "Operating Hours" divided by the "Number of Equipment Failures".

"Operating Hours" means total power on hours less any time when the WREN III HH is not functioning properly. "Equipment Failure" means any stoppage or substandard performance of the equipment because of equipment malfunction, excluding stoppages or substandard performance caused by operator error, adverse environment, power failure, host adapter (or other initiator) failure, cable failure, or other failure not caused by equipment.

The term equipment failure implies that maintenance is required because of a hardware failure.

6.2.2 Preventive Maintenance

No routine scheduled preventive maintenance shall be required.

6.2.3 Service Life

The WREN III HH shall have a useful service life of five years or 30,000 hours, whichever occurs first, before requiring factory refurbishment. Depot repair or replacement of major parts will be permitted during the lifetime (6.2.4).

6.2.4 Service Philosophy

Special equipment is required to repair the WREN III HH HDA. Repairs may be performed only at a properly equipped and staffed depot service and repair facility.

6.2.5 Installation

The WREN III HH is designed, manufactured, and tested with a "Plug in and Play" installation philosophy. This philosophy minimizes the requirements for highly trained personnel to integrate the WREN III HH into the OEM's system, whether in a factory or field environment.

6.2.6 Service Tools

No special tools are required for site installation or recommended for site maintenance. Refer to paragraph 6.2.4. The depot repair philosophy of WREN III HH precludes the necessity for special tools. If field repair of items external to the HDA is desired, two sizes of 6 point Torx drivers are required (T10 and T15). They may be purchased through most commercial tool catalogs.

7.0 PHYSICAL/ELECTRICAL SPECIFICATIONS

7.1 AC POWER REQUIREMENTS: None

7.2 DC POWER REQUIREMENTS

The voltage and current requirements for a single WREN III HH are shown in the following table. Values indicated apply at the drive power connector.

TABLE 1. DC POWER REQUIREMENTS

Voltage	+5 V	+12 V
Regulation	$\pm 5\%$	$\pm 5\%$ [2]
Noise Immunity [3]	100 mV	100 mV
Maximum Operating Current [1]	1.3 A	1.7 A
Typical Idle Current [1][4]	1.0 A	1.0 A
Maximum Starting Current (Peak)	1.7 A	4.5 A
Delayed Motor Start (Max) [5]	1.7 A	0.8 A

[1] Measured with average reading DC ammeter.

[2] A $\pm 10\%$ tolerance is permissible during power up. The $\pm 5\%$ must be maintained after the drive signifies that its power up sequence has been completed and that the drive is able to accept selection by the Host Initiator.

[3] Noise is specified as periodic and random distribution of frequencies covering a band from DC to to 10 MHz. Values given are peak to peak measurements

[4] See +12 V current profile level T6 in Figure 3.

[5] This condition occurs when the Motor Start Option is enabled and the drive has not yet received a Start Motor command.

Note 1:

At powerup, the motor current regulator will limit the 12 volt current to a peak value of less than 4.5 amperes.

Note 2:

Minimum current loading for each supply voltage is not less than 30% of the maximum operating current shown in Table 1.

Note 3:

The +5 and +12 volt supplies shall employ separate ground returns.

Note 4:

Where power is provided to multiple drives from a common supply, careful consideration for individual drive power requirements should be noted. Where multiple units are powered on simultaneously, the peak starting current must be available to each device. (Ref. Table 1).

7.2.1 Power Sequencing

Power sequencing is not required for the WREN III HH. The WREN III HH protects against inadvertent writing during power up and down. Daisychain operation requires that power be maintained on the terminated WREN III HH to ensure proper termination of the peripheral I/O cables.

7.2.2 12 V - Current Profile

Figure 3 identifies the WREN III HH 12 V current profile. The current during the various times is as shown:

- T1 - Power is initially applied to the WREN III HH and the controller performs a self check.
- T2 - The spindle begins to accelerate under current limiting.
- T3 - The spindle continues to accelerate under current limiting conditions.
- T4 - The arm restraint solenoid is released.
- T5 - The spindle is up to speed.
- T6 - The autovelocity adjust sequence and controller initialization is performed.
- T7 - Velocity is set and the WREN III HH is ready for reading and writing.
- T8 - Power is removed from the WREN III HH.

NOTE

All times and currents are typical. See Table 1 for maximum current requirements.

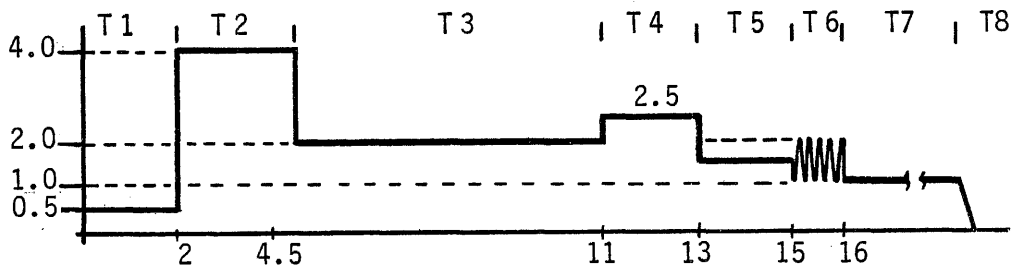
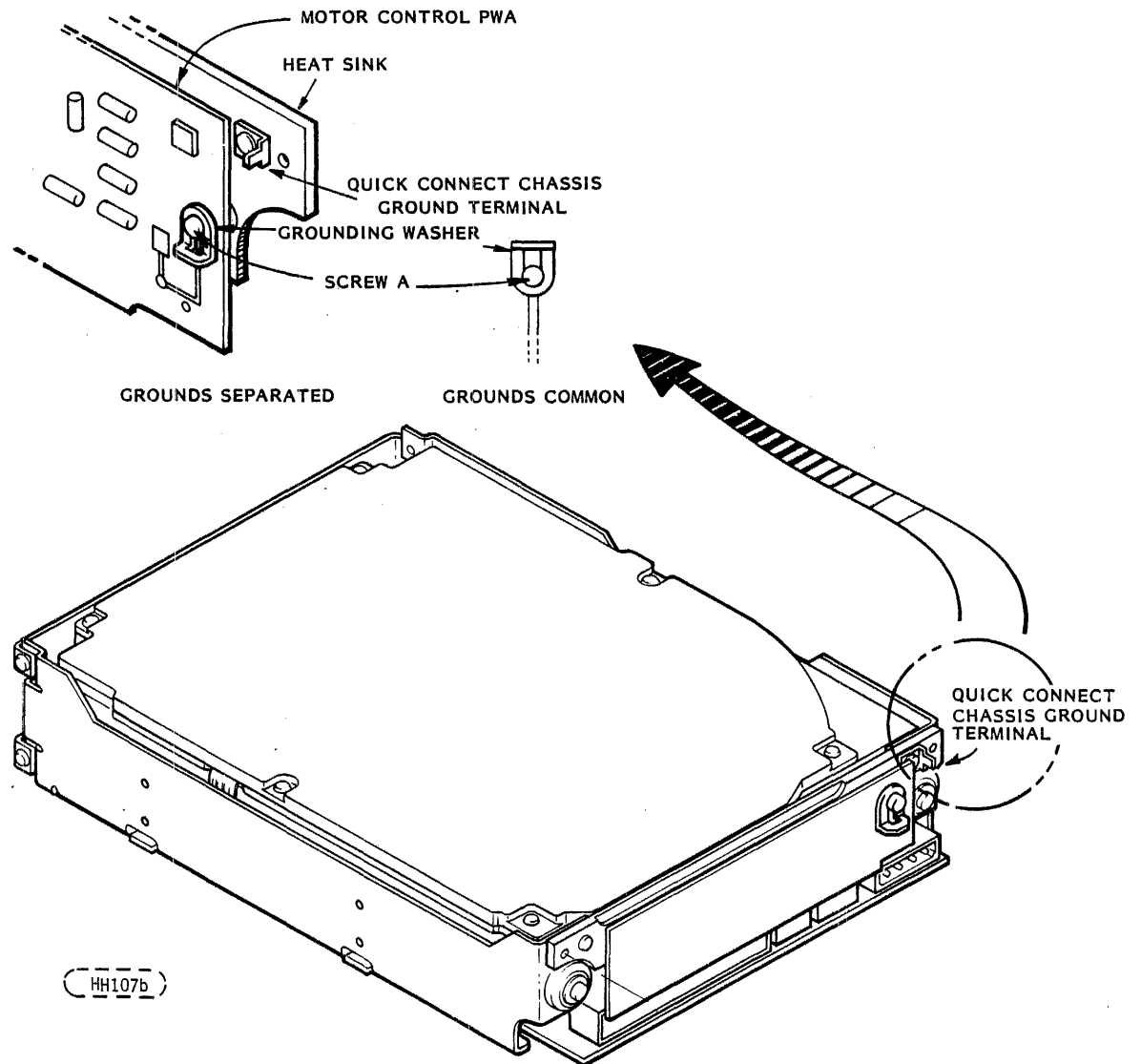

FIGURE 3. TYPICAL WREN III HH +12 V CURRENT PROFILE

7.2.3 System Grounds

The WREN III HH is shipped with the DC/HDA logic ground and chassis ground joined together. These two ground planes may be separated by repositioning the "U" shaped grounding washer on the motor control PWA as shown in Figure 4. NOTE: To separate the grounds, loosen the screw "A" and reorient the washer so that it does not contact the ground run near the screw at any point (left view).

Hold the washer in place and retighten the screw.



*Mating Connector Part Number is AMP 62137-2

FIGURE 4. GROUNDS SEPARATION DETAIL

7.3 HEAT/POWER DISSIPATION

Each WREN III HH will dissipate no more than 27 watts (93 BTUs per hour) of DC power average. Typical power dissipation under idle operating conditions is less than 18 watts.

7.4 ENVIRONMENTAL LIMITS

Temperatures and humidity specifications preclude condensation on any WREN III HH part. Altitude and atmospheric pressure specifications are referenced to a standard day at 58.7°F (14.8°C). Corresponding maximum Wet Bulb temperature is 82°F (28°C).

7.4.1 Temperature

a. Operating

50°F to 122°F (10°C to 50°C) operating ambient with a maximum gradient of 18°F (10°C) per hour. Above 1000 feet (305 metres) altitude the maximum temperature is derated linearly to 112°F (44.4°C) at 10,000 feet (3048 metres). Cabinet packaging designs must provide ample air circulation around the WREN III HH to ensure environmental limits are not exceeded as a result of heat transfer from other system components. Operating ambient for specification purposes is defined as the environment immediately surrounding the WREN III HH. The temperature of the HDA is restricted to a maximum of 142°F (61.4°C) during operation as shown in Figure 4. System cooling consideration should avoid large thermal gradients between points A and B. (See Figure 4a).

b. Transit

-40° to 158°F (-40° to 70°C) package ambient with a maximum gradient of 36°F (20°C) per hour. This specification assumes that the WREN III HH is packaged in the shipping container designed by CDC for use with WREN III HH.

c. Storage

14° to 130°F (-10° to 54°C) device ambient with a maximum gradient of 27°F (15°C) per hour.

7.4.2 Relative Humidity

- a. Operating
8% to 80% relative humidity with a maximum gradient of 10% per hour.
- b. Transit
5% to 95% relative humidity.
- c. Storage
8% to 90% relative humidity.

7.4.3 Effective Altitude (Sea Level Reference)

- a. Operating
-1000 to +10,000 feet (-305 to +3048 metres)
- b. Transit
-1000 to +40,000 feet (-305 to +12,210 metres)
- c. Storage
-1000 to +10,000 feet (-305 to +3048 metres)

7.4.4 Shock and Vibration

Shock and vibration limits specified in this document are measured directly on the WREN III HH chassis. If the WREN III HH is installed in an enclosure to which the stated shock and/or vibration criteria is applied, resonances may occur internally to the enclosure resulting in WREN III HH movement in excess of the stated limits. If this situation is apparent, it may be necessary to modify the enclosure to minimize WREN III HH movement.

The limits of shock and vibration defined within this document are specified with the WREN III HH mounted by any of the four methods shown in Figure 5.

7.4.4.1 Shock

- a. Operating - Normal

Equipment, as installed for normal operation, shall comply with the complete specified performance while subjected to intermittent shock not exceeding 2.0 g at a maximum duration of 10 ms (half sinewave). Shock may be applied in the X, Y, or Z axis. Shock is not to be repeated more than two times per second.

7.4.4.1 (continued)

b. Operating - Abnormal

Equipment, as installed for normal operation, shall not incur physical damage while subjected to intermittent shock not exceeding 10.0 g at a maximum duration of 10 ms (half sinewave). Shock occurring at abnormal levels may promote degraded operational performance during the abnormal shock period. Specified operational performance will continue when normal operating shock levels resume. Shock may be applied in the X, Y, or Z axis. Shock is not to be repeated more than two times per second.

c. Nonoperating

The limits of nonoperating shock shall apply to all conditions of handling and transportation. This includes both isolated devices and integrated equipment.

Equipment subjected to nonrepetitive shock not exceeding 32.0 g at a maximum duration of 10 ms (half sinewave) shall not exhibit device damage or performance degradation. Shock may be applied in the X, Y, or Z axis.

d. Packaged

The WREN III HH as packaged by CDC for general freight shipment shall withstand drop test from 42 inches (1070 mm) against a concrete floor or equivalent. (See Figure 6.).

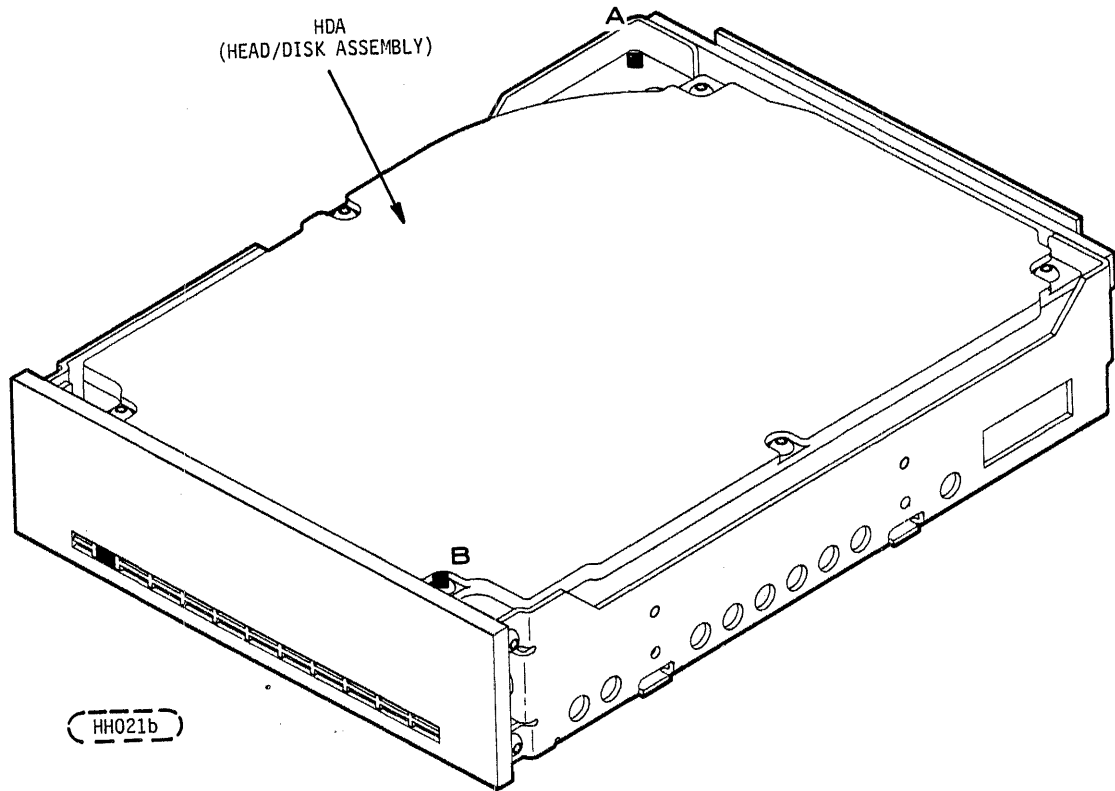
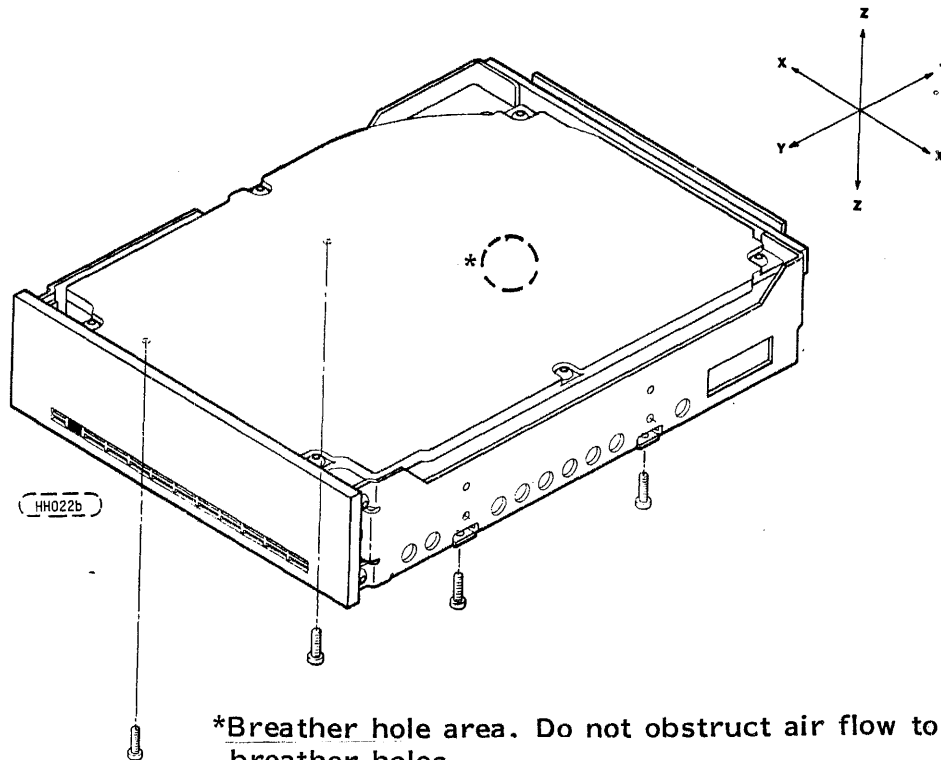
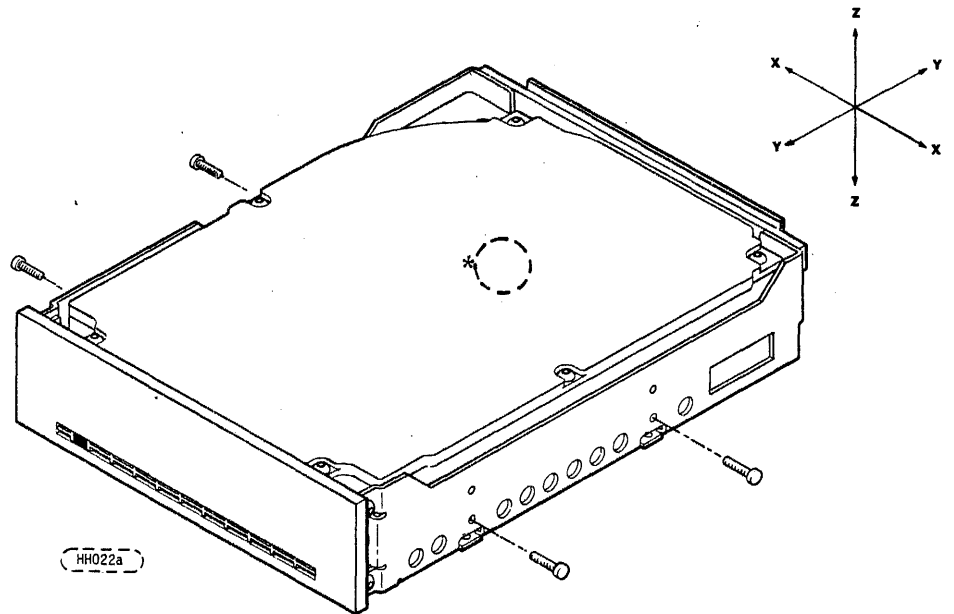

FIGURE 4a. HDA TEMPERATURE MONITORING LOCATIONS

7.4.4.1 (continued)

Points A and B should not exceed 142°F (61.4°C) during operation. Large thermal gradients between Points A and B should be avoided.



*Breather hole area. Do not obstruct air flow to breather holes.

FIGURE 5. RECOMMENDED HORIZONTAL MOUNTING

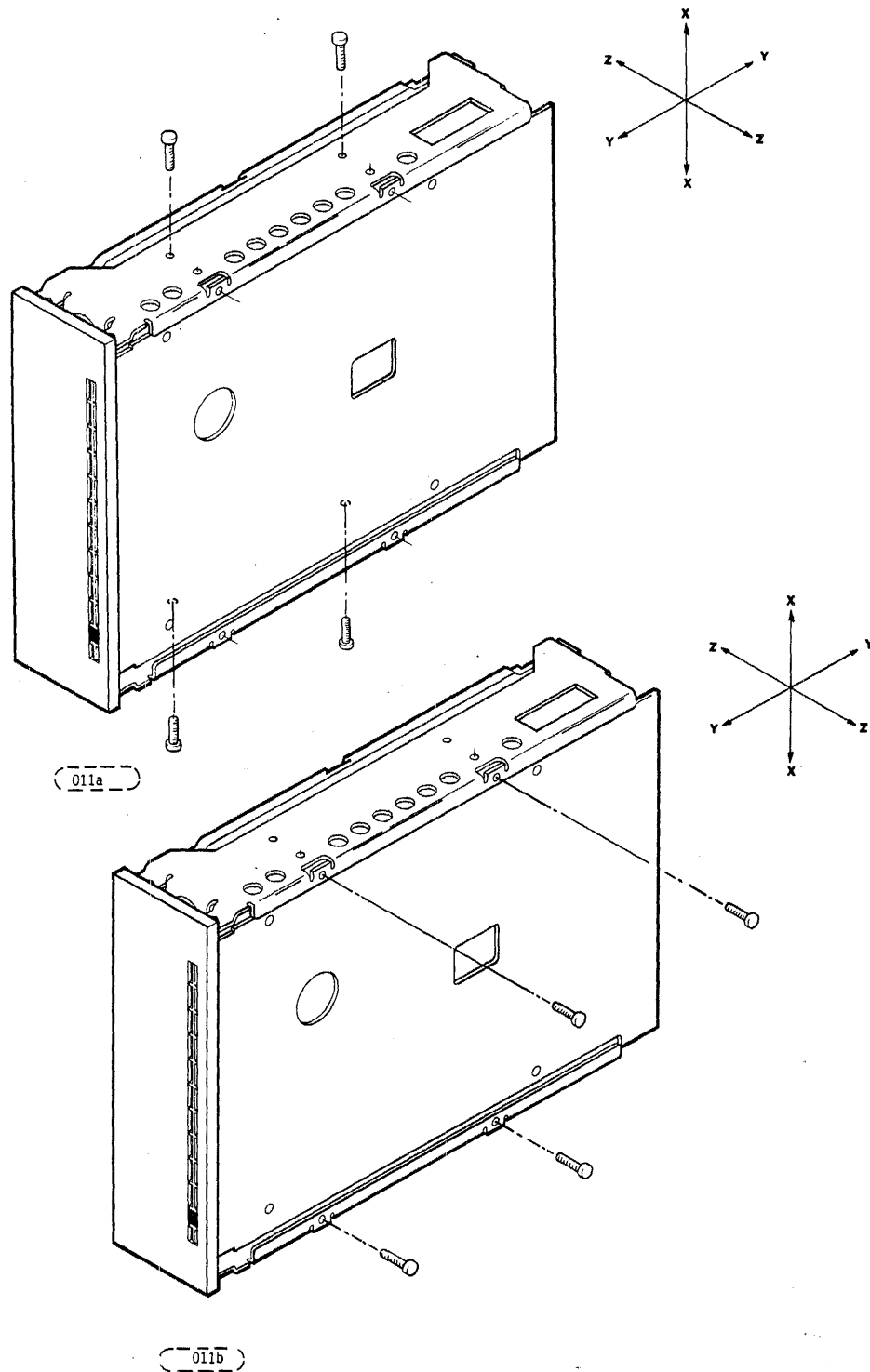

FIGURE 6. RECOMMENDED VERTICAL MOUNTING

7.4.4.2 Vibration

- a. Operating - Normal
Equipment as installed for normal operation, shall comply with the complete specified performance while subjected to continuous vibration not exceeding
5-22 Hz @ 0.010 inches displacement
22-500 Hz @ 0.25 g
Vibration may be applied in the X, Y, or Z axis.
- b. Operating - Abnormal
Equipment as installed for normal operation, shall not incur physical damage while subjected to periodic vibration not exceeding
15 minutes of duration at major resonant frequency
5-22 Hz @ 0.010 inches displacement
22-500 Hz @ 0.50 g

Vibration occurring at these levels may promote degraded operational performance during the abnormal vibration period. Specified operational performance will continue when normal operating vibration levels are resumed. This assumes system recovery routines are available. Abnormal vibration may be applied in the X, Y, or Z axis.

- c. Nonoperating
The limits of nonoperating vibration shall apply to all conditions of handling and transportation. This includes both isolated devices and integrated equipment.

Equipment shall not incur physical damage or degraded performance as a result of continuous vibration not exceeding

5-22 Hz @ 0.020 inches displacement
22-500 Hz @ 1.0 g

Vibration may be applied in the X, Y, or Z axis.

7.4.5 Air Cleanliness

The WREN III HH is designed to operate in a typical office environment with minimal environmental control.

7.5 MECHANICAL SPECIFICATIONS

The following nominal dimensions are exclusive of the decorative front panel accessory. Refer to Figure 7 for detailed mounting configuration dimensions.

Height: 1.625 in 41.3 mm
 Width: 5.75 in 146.05 mm
 Depth: 8.1 in 205.7 mm
 Weight: 4.2 pounds 1.9 kilograms

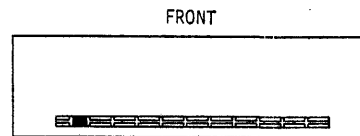
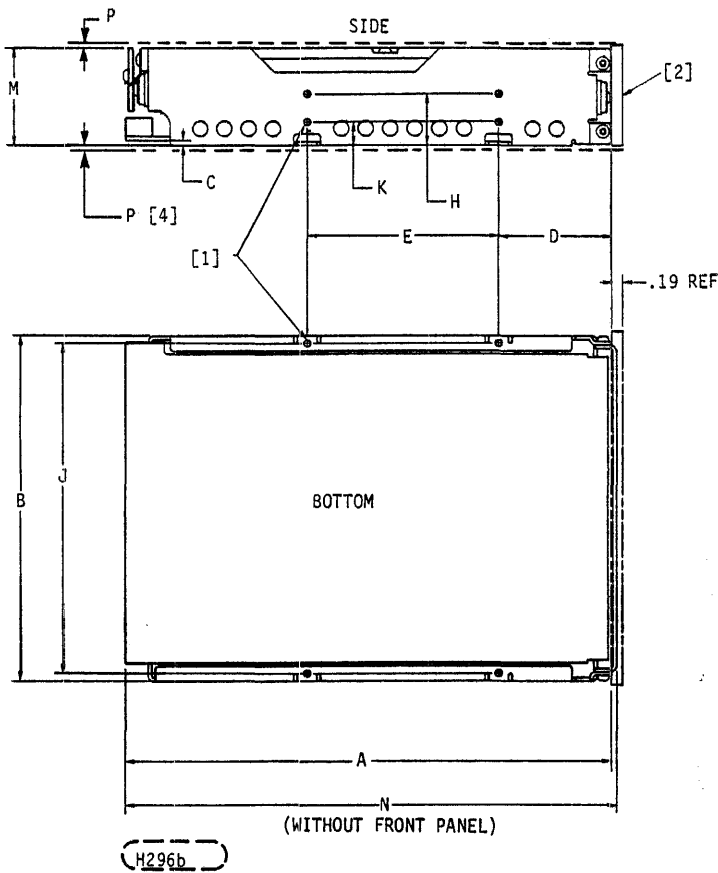

- NOTES:
- [1] MOUNTING HOLES (6-32 UNC-28). FOUR ON BOTTOM, FOUR ON EACH SIDE. MAX SCREW LENGTH INTO CHASSIS 0.25 IN. (6.35 mm), EXCEPT FOUR HOLES AT H DIMENSION 0.125 IN. (3.17 mm).
 - [2] FRONT PANEL
 - 3. WEIGHT IS APPROX. 3.8 LBS (1.72 kg).
 - [4] 0.03 INCH (P) SWAY SPACE SHOULD BE PROVIDED IF 10 G SHOCK IMMUNITY IS REQUIRED.

	INCHES	MILLIMETRES
A	8.0	203.2
B	5.75 +0.00 -0.03	146.0
C	0.100	2.5
D	1.87 ±0.02	47.5
E	3.12 ±0.01	79.2
H	0.86	21.8
J	5.50 ±0.02	139.7
K	0.39	9.9
M	1.625 ±0.02	41.3
N	8.07	205.7
P	0.030	0.76

FIGURE 7. MOUNTING CONFIGURATION DIMENSIONS

7.5.1 Drive Orientation

Only two WREN III HH mounting orientations are permitted: disks in the horizontal plane and disks in the vertical plane. Horizontal mounting (Figure 5) with the front (non I/O cable end) raised as much as 15° above the horizontal is acceptable. Mounting with either end down (front or rear) or upside down is not permissible. It is recommended that data written in a given orientation be read in that same orientation.

7.5.2 Cooling

Cabinet cooling must be designed by the customer so the ambient temperature immediately surrounding the WREN III HH will not exceed temperature conditions specified in 7.4.1. Specific consideration should be given to make sure adequate air circulation is present around the PWAs at the rear of the drive.

8.0 MEDIA CHARACTERISTICS

8.1 MEDIA DESCRIPTION

The media used on the WREN III HH has a diameter of approximately 5 1/4 inches (130 mm). The aluminum substrate is coated with a thin film magnetic material, overcoated with a proprietary protective layer for improved durability and environmental protection.

9.0 DEFECT AND ERROR MANAGEMENT

WREN III HH, as delivered, complies with this specification. The read error rate and specified storage capacity are not dependent upon use of defect management routines by the host (initiator).

Defect and error management in the SCSI system involves WREN III HH internal defect/error management and SCSI systems error considerations (errors in communications between Initiator and WREN III HH). Tools for use in designing a defect/error management plan are briefly outlined in this section, with references to other sections where further details are given.

9.1 WREN III HH INTERNAL DEFECTS/ERRORS

Identified defects are recorded on the WREN III HH defects list tracks (referred to as the primary or ETF defect list). It is recommended that these known defects be reallocated during the initial WREN III HH format operation. (See Format Unit command in Section 14.2.1.1.) The WREN III HH internal retries and data correction by ECC should be enabled to recover data from additional flaws if they occur. If data correction by ECC is required to recover data, the host should immediately reallocate this sector by use of the Reassign Blocks command. (See Section 14.2.1.3.) If the WREN III HH automatic retries and data correction by ECC feature are not used, defects are usually unrecoverable and need to be reallocated as they are discovered. One spare sector per track and up to X (where "X" is the number of R/W heads installed) spare sectors per cylinder are available for reallocation of bad sectors. After formatting, defects can be automatically reallocated by the WREN III HH, or can be reallocated when the host sends the Reassign Blocks Command (Section 14.2.1.3).

Once the necessary details are described about the operation of the interface, (Sections 10 thru 14) a more thorough discussion of the WREN III HH Error Recovery Philosophy is presented in Section 16.0.

9.2 SCSI SYSTEMS ERROR CONSIDERATIONS

Information on the reporting of operational errors or faults across the interface is given in Sections 12.5.2, 14.1.1, and 15.0. Section 12.5.2 of this specification and Section 5.5 of the CDC SCSI Specification describe the Message Protocol System. Several of the messages are used in the SCSI systems error management system. The Request Sense command returns information to the host about numerous kinds of errors or faults. The Receive Diagnostic Results reports the results of diagnostic operations performed by the WREN III HH.

Section 15.0 describes the status returned by the WREN III HH to the Initiator. Status reporting plays a role in the SCSI systems error management and its use in that respect is described in sections where the various commands are discussed.

10.0 INTERFACE REQUIREMENTS AND OPTIONS

10.1 GENERAL DESCRIPTION

This specification describes the Magnetic Peripherals Inc. subset of the SCSI (Small Computer Systems Interface) as implemented on the WREN III HH. The interface is compatible with the mandatory subset of the CDC SCSI Interface Specification (both are compatible with the ANSI SCSI standard). The WREN III HH Model 94211 is classified as an "Intelligent" peripheral.

The WREN III HH interface consists of a 9 bit bidirectional bus (8 data + 1 parity) plus 9 control signals supporting multiple initiators, command queuing of up to one command per initiator, disconnect/reconnect, self configuring host software and automatic features that relieve the host from the necessity of knowing the physical architecture of the target (logical block addressing is used).

The physical interface consists of single ended drivers and receivers using asynchronous communication protocols which support cable lengths of up to 6 metres and a bus interface transfer rate up to 1.25 MB per second. The bus protocol supports multiple initiators, disconnect/reconnect, additional messages plus 6 byte and 10 byte Command Descriptor Blocks. The WREN III is always a target on the SCSI.

10.2 DC CABLE AND CONNECTOR

The WREN III receives DC power through a 4 pin right angle connector (see Table 2a for pin assignment) mounted on the main PWA (see Figure 9). Recommended part numbers of the mating connector are listed below, but equivalent parts may be used (see Table 2b).

TABLE 2a. DC INTERFACE

<u>POWER LINE DESIGNATION</u>	<u>PIN NUMBER</u>
+12 V	J2-01
+12 V Return	J2-02
+ 5 V Return	J2-03
+ 5 V	J2-04

TABLE 2b. MATING CONNECTOR PARTS

<u>TYPE OF CABLE</u>	<u>CONNECTOR</u>	<u>CONTACTS (20-14 AWG)</u>
14 AWG	AMP 1-480424-0	AMP 60619-4 (Loose Piece) AMP 61117-4 (Strip)

10.3 PHYSICAL CHARACTERISTICS

This section defines the connectors, cables, signals, terminators and bus timing needed to implement SCSI. Refer also to Sections 4.0 thru 4.4 in the CDC SCSI Interface Specification.

10.3.1 Physical Description

Model 94211 WREN may be daisy chained together or with other compatible SCSI devices using a common cable. Both ends of the cable must be terminated. The WREN III HH implements single ended drivers and receivers which allow a maximum cable length of six metres (primarily for connection within a cabinet). All signals are common between all SCSI devices. The Model 94211 WREN III may be daisy chained only with SCSI devices with single ended drivers and receivers. A maximum of 8 SCSI devices (including the Host) may be daisy chained together. The SCSI Devices at both ends of the daisy chain are to be terminated. Intermediate SCSI devices shall not be terminated. (see Figure 8).

10.3.2 CABLE REQUIREMENTS

Only nonshielded cable connectors are applicable. A 50 conductor flat cable or 25 twisted pair cable shall be used. The maximum total cable length shall be 6.0 metres. A stub length of no more than 0.1 metres is allowed off the mainline interconnection within any connected equipment.

An ideal impedance match with cable terminators implies a cable characteristic impedance of 132 ohms (singled-ended option). In general, cables with this high of a characteristic impedance are not available; however, impedance of 100 ohms \pm 10% is recommended for unshielded flat or twisted pair ribbon cable. However, most available cables have a somewhat lower characteristic impedance. To minimize discontinuities and signal reflections, cables of different impedances should not be used in the same bus. Implementations may require trade-offs in shielding effectiveness, cable length, the number of loads, transfer rates, and cost to achieve satisfactory system operation. To minimize discontinuities and signal reflections, cables of different impedances should not be used on the same bus. If shielded and unshielded cables are mixed within the same SCSI bus, the effect of impedance mismatch must be carefully considered.

A minimum conductor size of 28 AWG should be used to minimize noise effects.

Suggested non-shielded flat cable part numbers are:

- Flat Cable: 3M-3365-50
- Twisted Pair: Spectra Twist in flat 455-248-50

Equivalent parts may be used.

Single ended cable pin assignments are shown in Table 3.

10.3.3 CONNECTORS REQUIREMENTS

The nonshielded cable connector shall be a 50 conductor connector consisting of two rows of 25 female contacts with adjacent contacts 100 mils apart.

Recommended Mating Flat Cable Connector Part Numbers are:

Closed end (for cable ends)*	3M-3425-7600	W/O Strain Relief, with Center Key
	3M-3425-7650	With Strain Relief, with Center Key
	Dupont-66900-290	With Strain Relief, with Center Key
Open end (in daisychain)*	3M-3425-6600	W/O Strain Relief, with Center Key
	3M-3425-6650	With Strain Relief, with Center Key
	Dupont-66900-250	With Strain Relief, with Center Key

* See Figure 8.

10.3.3 continued

The Model 94211 WREN device connector is a nonshielded 50 conductor connector consisting of two rows of 25 male pins with adjacent pins 100 mils apart. The connector is keyed.

Drive Connector Part Number: Berg - 65496 - 031 or equivalent.

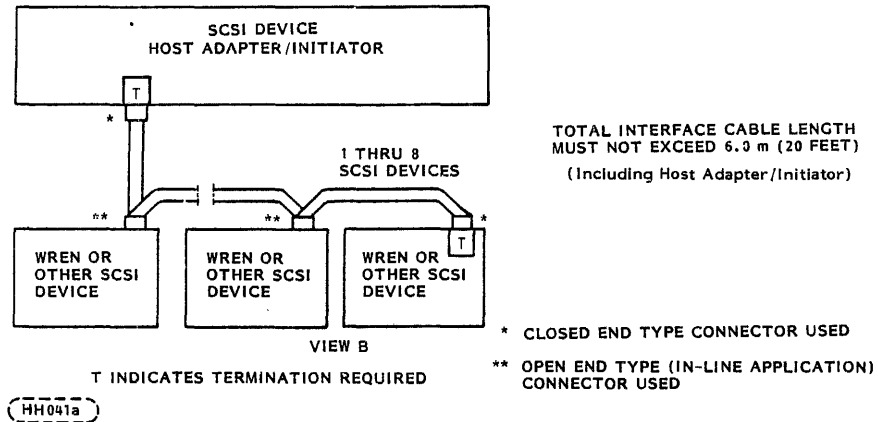

FIGURE 8. INTERFACE CABLING

TABLE 3. SINGLE ENDED CABLE PIN ASSIGNMENTS (NONSHIELDED CONNECTOR)

<u>SIGNAL</u>	<u>PIN NUMBER</u>	<u>SIGNAL</u>	<u>PIN NUMBER</u>
-DB(0)	2	GROUND	30
-DB(1)	4	-ATN	32
-DB(2)	6	GROUND	34
-DB(3)	8	-BSY	36
-DB(4)	10	-ACK	38
-DB(5)	12	-RST	40
-DB(6)	14	-MSG	42
-DB(7)	16	-SEL	44
-DB(P)	18	-C/D	46
GROUND	20	-REQ	48
GROUND	22	-I/O	50
GROUND	24		
TERMPWR	26		
GROUND	28		

NOTES:

1. All odd pins except pin 25 are connected to ground. Pin 25 is left open.
2. The minus sign next to the signals indicates active low.

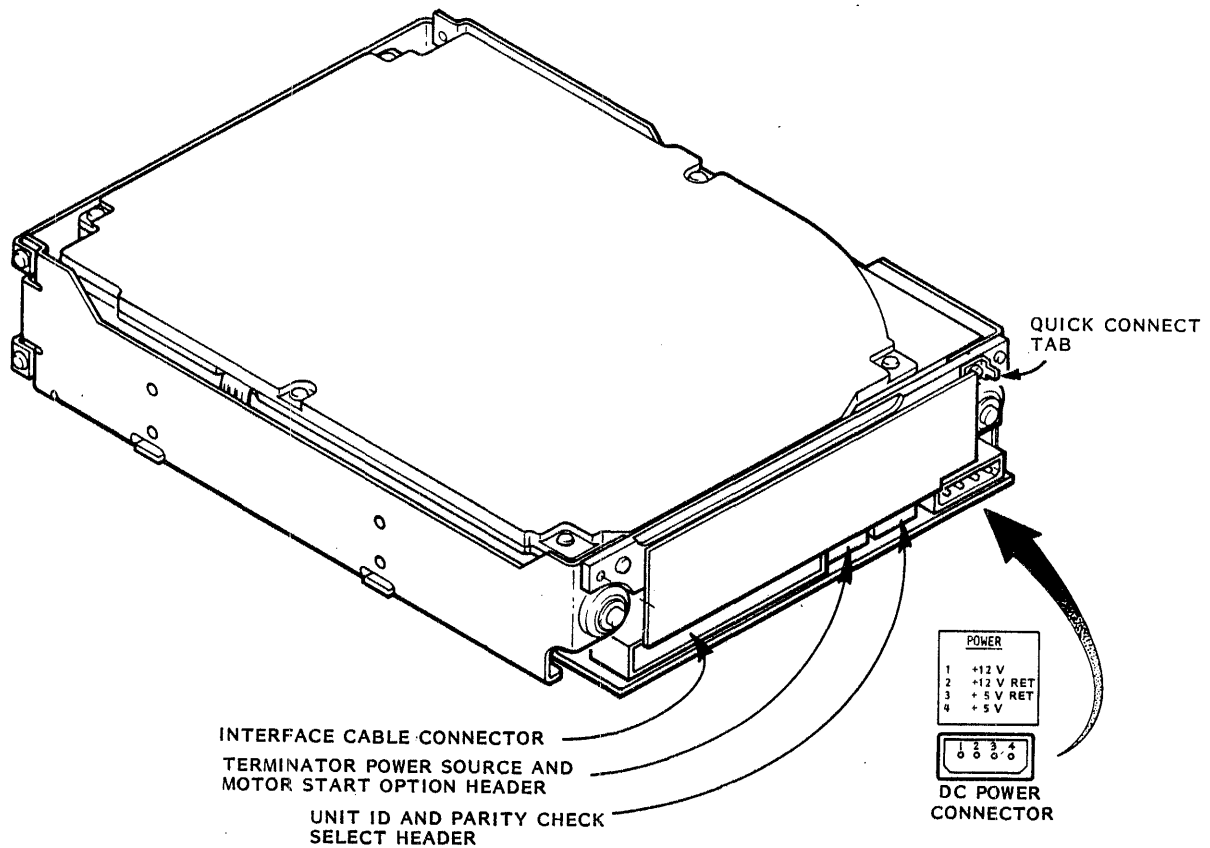

HH071d

SEE FIGURE 10 AND 13 FOR MORE DETAILS

FIGURE 9. I/O CONNECTION

10.3.4 Electrical Description

All interface signals with the Model 94211 WREN III HH are single ended and must be terminated with 220 ohms to +5 V and 330 ohms to ground at each end of the total cable. All signals use open collector or three state drivers. Optional termination is available internal to the WREN III HH. See Figure 10.

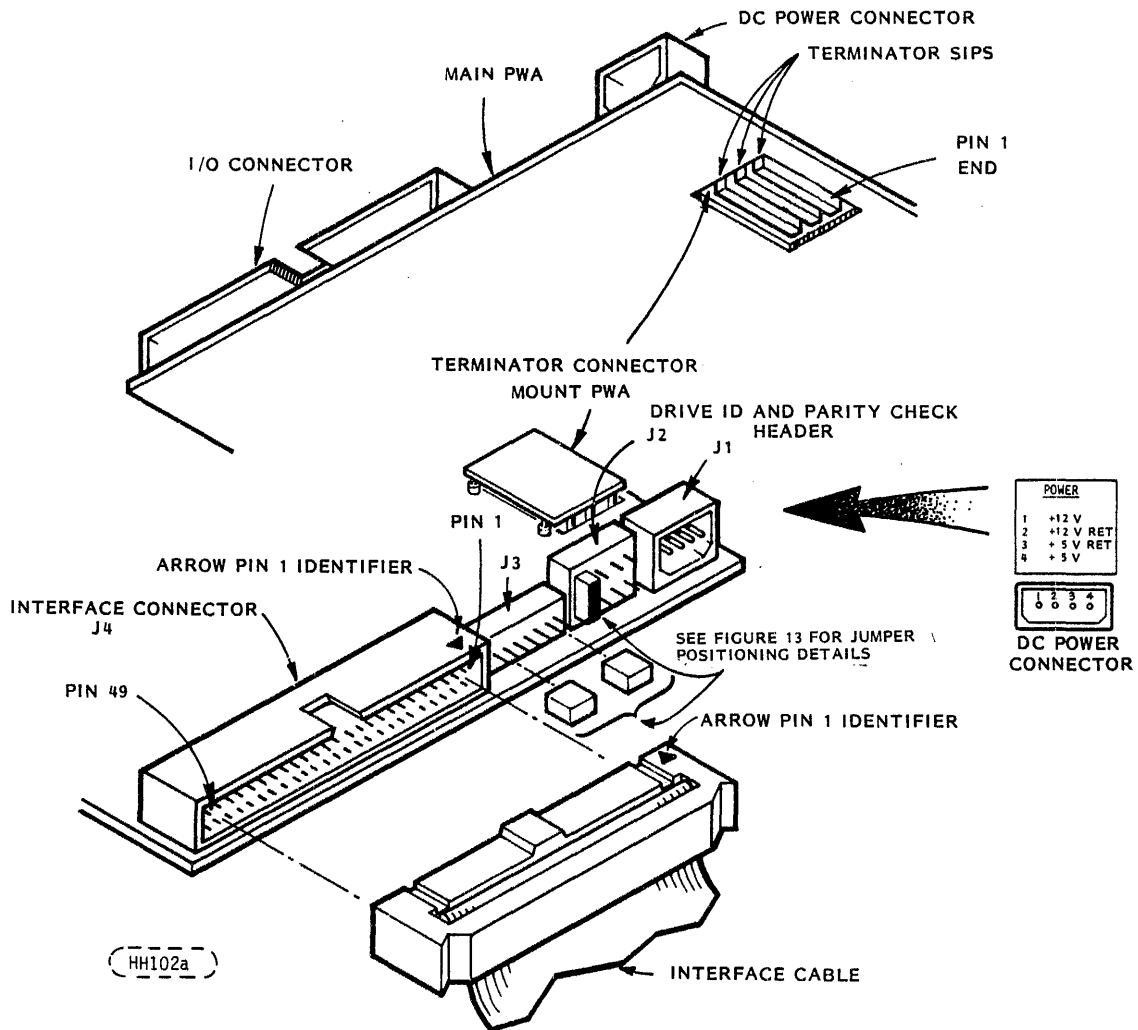

FIGURE 10. CABLE CONNECTION

10.3.4.1 Single Ended Drivers/Receivers

Single ended drivers and receivers are used by the WREN III HH. Typical circuits are shown in Figure 11. Terminator circuits shown are there only when the WREN III HH is last in the daisychain.

Transmitter Characteristics

The WREN III HH uses an ANSI SCSI compatible open collector single ended driver. This driver is capable of sinking a current of 48 mA with a low level output voltage of 0.4 volt.

Receiver Characteristics

The WREN III HH uses a ANSI SCSI single ended receiver with hysteresis gate or equivalent as a line receiver.

10.3.4.2 Terminator Requirements

Internal WREN III HH I/O termination consist of three resistor modules which plug into sockets on the underside of the main PWA (see Figure 10). The WREN III HH may be ordered with or without these termination resistors to facilitate a particular application. All single initiator/single target (nondaisychain) applications require that the Initiator and WREN III HH be terminated. Daisychain applications require that only the last physical units at each end of the daisychain be terminated. All other peripherals on the chain should not be terminated. (See Figure 8). Physically remove terminator resistor packs where terminators are not required. Removal of power source selection jumper* 4 does not disconnect the terminator resistors from the circuit.

10.3.4.3 Terminator Power

The WREN III HH does not supply Terminator power for the SCSI bus. The WREN III HH may be optionally configured* to accept terminator power via Pin 26 of the SCSI bus or to provide terminator power for optional internal termination resistors via the WREN III HH power connector. See Figure 10 and 13.

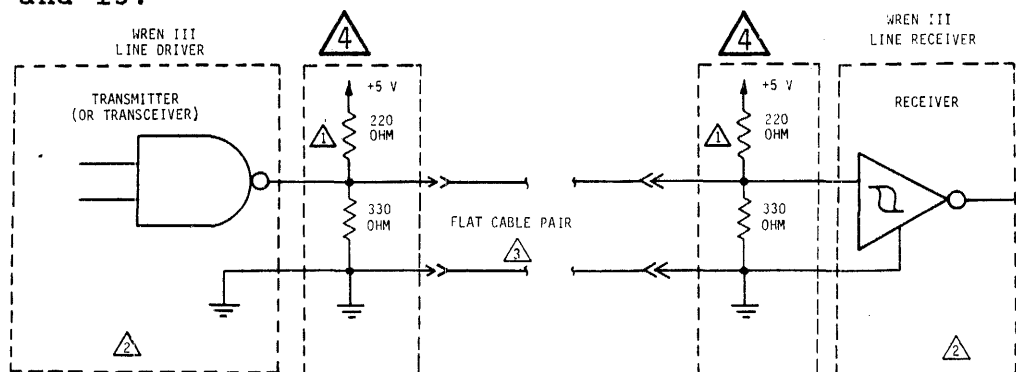

△ TERMINATOR CIRCUITS: PART OF REMOVABLE TERMINATOR RESISTOR PACKS, USED IN THE WREN III WHEN IT IS LAST IN THE DAISYCHAIN.

INTERFACE SIGNALS LEVELS AND LOGICAL SENSE AT THE WREN I/O CONNECTOR ARE DEFINED AS FOLLOWS:

LOGIC LEVEL		DRIVER OUTPUT	RECEIVER INPUT
NEGATED	(0)	$\geq 2.5 \text{ V}; \leq 5.25 \text{ V}$	$\geq 2.0 \text{ V}; \leq 5.25 \text{ V}$
ASSERTED	(1)	$\leq 0.4 \text{ V}; \geq 0.0 \text{ V}$	$\leq 0.8 \text{ V}; \geq 0.0 \text{ V}$

THE DIFFERENCE IN THE VOLTAGES BETWEEN INPUT AND OUTPUT SIGNALS IS DUE TO THE LOSSES IN THE CABLE.

- △ ANSI SCSI COMPATIBLE CIRCUITS
- △ TOTAL INTERFACE CABLE LENGTH SHOULD NOT EXCEED 20 FEET (6.0 m) FROM HOST TO END OF DAISYCHAIN.
- △ SOURCE OF DRIVE TERMINATOR POWER SELECTABLE BY JUMPER PLUG.

(HH041b)

*See Figure 13 for configuration details.

FIGURE 11. SINGLE ENDED TRANSMITTERS AND RECEIVERS

11.0 SCSI BUS

Communication on the SCSI Bus is allowed between only two SCSI devices at a time. There can be a maximum of eight SCSI devices including the host computer(s) connected to the SCSI bus. Each SCSI device has a SCSI ID Bit assigned as shown in Figure 12. The SCSI ID is assigned by installing from 0 to 3 jumper plugs onto a connector in a binary coded configuration during system configuration. See Figure 13.

When two SCSI devices communicate on the SCSI Bus one acts as an initiator and the other acts as a target. The initiator (typically a host computer) originates an operation and the target performs the operation. The WREN III HH always operates as a target.

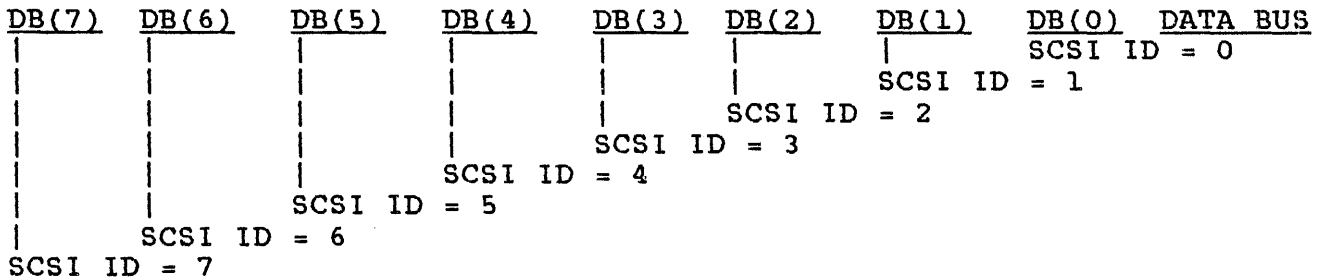

The Host Adapter/Initiator must be identified by one of the eight SCSI Device Addresses.

FIGURE 12. SCSI ID BITS

Certain SCSI bus functions are assigned to the initiator and certain SCSI bus functions are assigned to the target. The initiator will select a particular target. The target will request the transfer of Command, Data, Status or other information on the data bus.

Information transfers on the data bus are asynchronous and follow a defined REQ/ACK Handshake protocol. One byte of information will be transferred with each handshake.

The WREN III HH supports single initiator, single target; single initiator, multiple target; or multiple initiator, multiple target bus configurations.

11.1 SCSI BUS SIGNALS

There are nine control and nine data signals, listed below:

- BSY
- SEL
- C/D
- I/O
- MSG
- REQ
- ACK
- ATN
- RST
- DB(7-0,P)

11.1 (continued)

These signals are described as follows:

BSY (Busy) - An "OR-tied" signal that indicates the bus is being used.

SEL (Select) - A signal used by an initiator to select a target or by a target to reselect an initiator.

C/D (Control/Data) - A signal driven by a target that indicates whether Control or Data information is on the Data Bus. True (see paragraph 11.1.1) indicates Control.

I/O (Input/Output) - A signal driven by a target that controls the direction of data movement on the Data Bus with respect to an initiator. True indicates input to the initiator. This signal is also used to distinguish between Selection and Reselection phases.

MSG (Message) - A signal driven by a target during the Message phase.

REQ (Request) - A signal driven by a target to indicate a request for REQ/ACK data transfer handshake.

ACK (Acknowledge) - A signal driven by an initiator to indicate an acknowledgment for a REQ/ACK data transfer handshake.

ATN (Attention) - A signal driven by an initiator to indicate the Attention condition.

RST (Reset) - An "OR-tied" signal that indicates the RESET condition.

DB(7-0,P) (Data Bus). Eight data bit signals, plus a parity bit signal that form a Data Bus. DB(7) is the most significant bit and has the highest priority during the Arbitration phase. Bit number significance, and priority decrease downward to DB(0). A data bit is defined as one when the signal value is true (asserted) and is defined as zero when the signal value is false (negated).

Data parity DB(P) is odd - The use of parity is a system option. The WREN III HH SCSI will always generate parity, but has the capability to enable/disable parity detection. Parity is not valid during the Arbitration phase.

Refer to the CDC SCSI Interface Spec (64721700) for greater detail on each of the SCSI Bus signals.

11.1 (continued)

Drive Select

Install jumpers as shown in Figure 13 for SCSI ID selection. Refer to Figures 9 & 10 for the location of the drive select header. The WREN III HH can have one of eight ID bits selected by installing 0 to 3 jumpers in a binary coded configuration on the drive select header.

11.1.1 Signal Values

Signals may assume true or false values. There are two methods of driving these signals. In both cases, the signal shall be actively driven true, or asserted. In the case of OR-tied drivers, the driver does not drive the signal to the false state, rather the bias circuitry of the bus terminators pulls the signal false whenever it is released by the drivers at every SCSI device. If any driver is asserted, then the signal is true. In the case of non-OR-tied drivers, the signal may be actively driven false, or negated. Negated means that the signal may be actively driven false, or may be simply released (in which case the bias circuitry pulls it false), at the option of the implementer.

11.1.2 OR-Tied Signals

The BSY and RST signals shall be OR-tied only. In the ordinary operation of the bus, these signals are simultaneously driven true by several drivers. No signals other than BSY, RST, and DB(P) are simultaneously driven by two or more drivers, and any signal other than BSY and RST may employ OR-tied or non-OR-tied drivers. DB(P) shall not be driven false during the Arbitration phase. There is no operational problem in mixing OR-tied and non-OR-tied drivers on signals other than BSY and RST.

11.1.3 Signal Sources

Table 4 indicates which type of SCSI device is allowed to source each signal. All SCSI device drivers that are not active sources shall be in the passive state. Note that the RST signal may be sourced by any SCSI device at any time. The WREN III HH functions as a target, never as an initiator, and is capable of performing only the reselection function.

11.2 SCSI Bus Timing

Refer to CDC SCSI specification 64721700 for details on SCSI bus timing. All paragraphs 4.7.1 through 4.7.14 of 64721700 are applicable to the WREN III HH as specified with the exception of 4.7.2, 4.7.10, and 4.7.11, which are not applicable. In addition it is specified here that the WREN III HH will use the recommended 250 ms Selection Timeout Delay as suggested in Paragraph 4.7.14 of 64721700.

TABLE 4. SIGNAL SOURCES

<u>BUS PHASE</u>	<u>SIGNALS</u>					
	<u>BSY</u>	<u>SEL</u>	<u>C/D, I/O, MSG, REQ</u>	<u>I/O</u>	<u>ACK/ATN</u>	<u>DB(7-0,P)</u>
BUS FREE	None	None	None	None	None	None
ARBITRATION	All	Winner	None	None	None	SCSI ID
SELECTION	I&T	Init.	None	Init.[1]	Init.	Init.
RESELECTION	I&T	Target	Target	Target	Init.	Target
COMMAND	Target	None	Target	Target	Init.	Init.
DATA IN	Target	None	Target	Target	Init.	Target
DATA OUT	Target	None	Target	Target	Init.	Init.
STATUS	Target	None	Target	Target	Init.	Target
MESSAGE IN	Target	None	Target	Target	Init.	Target
MESSAGE OUT	Target	None	Target	Target	Init.	Init.

ALL: The signal shall be driven by all SCSI devices that are actively arbitrating.

SCSI ID: A unique data bit (the SCSI ID) shall be driven by each SCSI device that is actively arbitrating; the other seven data bits shall be released (i.e., not driven) by this SCSI device. The parity bit (DB(P)) may be undriven or driven to the true state, but shall never be driven to the false state during this phase.

I&T: The signal shall be driven by the initiator, target, or both, as specified in the Selection phase and Reselection phase.

Initiator: If this signal is driven, it shall be driven only by the active initiator.

None: The signal shall be released; that is, not be driven by any SCSI device. The bias circuitry of the bus terminators pulls the signal to the false state.

Winner: The signal shall be driven by the one SCSI device that wins arbitration.

Target: If the signal is driven, it shall be driven only by the active target.

[1] Initiator forces negation.

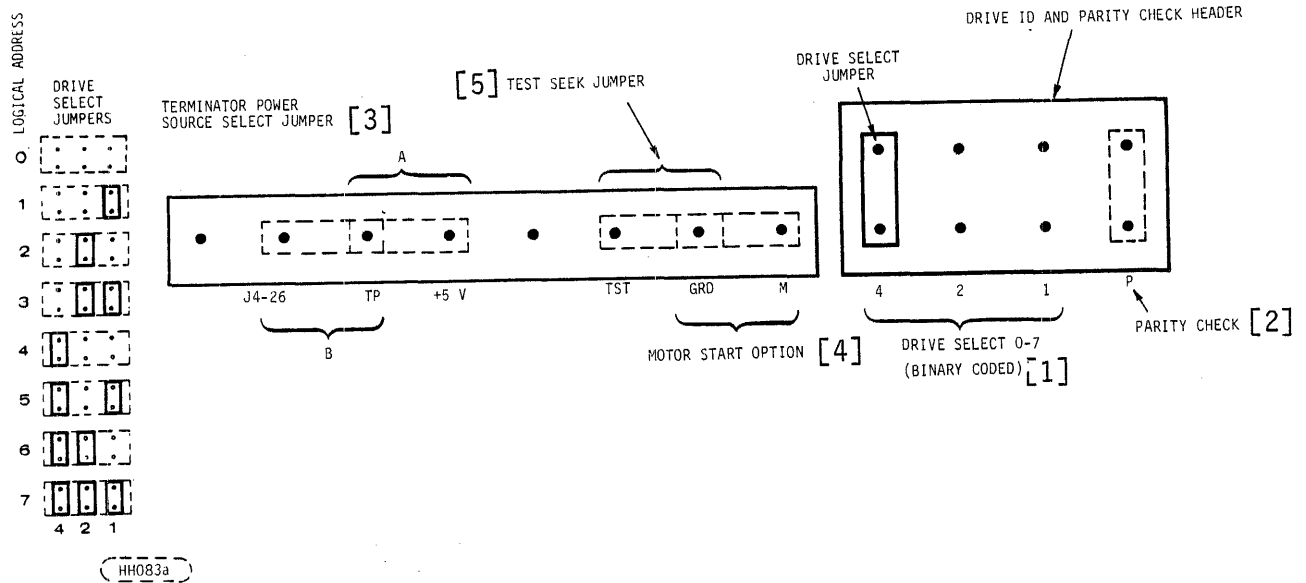

FIGURE 13. WREN III HH SCSI DRIVE ID AND OPTION SELECT HEADER

- [1] Drive ID is binary coded jumper position (most significant bit on left) , ie., jumper in position 4 would be Drive ID 4, no jumpers means ID 0.
- [2] Jumper plug installed means parity checking by the WREN III HH is enabled.
- [3] Jumper in position A means terminator power (+5V) is from WREN III HH power connector. Jumper in position B means terminator power is taken from interface cable, pin 26. If I/O cable is removed with jumper in Position B and with terminators in, drive will not power up.

If unit is not to be terminated, remove the terminator resistor packs. Removal of terminator power source select jumper does not disconnect the terminator resistors from the circuit.
- [4] Jumper plug installed enables the Motor Start Option. In this mode of operation the drive will wait for a Start Unit Command from the Host before starting the Motor. If the jumper plug is not installed the Motor will start as soon as DC power is applied to the unit (see section 14.2.1.11).
- [5] With the jumper in this position the unit will continuously perform test seeks to random cylinders. Motor starts as soon as DC power is applied.

12.0 LOGICAL CHARACTERISTICS

12.1 SCSI BUS PHASES

WREN III HH responds to 8 distinct bus phases as described in the CDC SCSI specification section 5.1.

Bus Free phase	
Arbitration phase	
Selection phase	
Reselection phase	
Command phase	These phases are collectively termed
Data (In and Out)	the Information Transfer phase.
Status (In Only)	
Message (In and Out)	

The SCSI Bus can never be in more than one phase at a time.

12.1.1 Bus Free Phase

Same as CDC SCSI Specification Section 5.1.1.

12.1.2 Arbitration Phase

WREN III HH supports arbitration by multiple SCSI devices as described in the CDC SCSI specification Section 5.1.2. The WREN III HH will arbitrate for the bus only as a target implementing reselection.

12.1.3 Selection Phase

Same as CDC SCSI Specification Section 5.1.3.

12.1.3.1 Nonarbitrating System

WREN III HH supports the selection sequence for nonarbitrating systems as described in the CDC SCSI Specification section 5.1.3.1.

12.1.3.2 Arbitrating Systems

WREN III HH supports the selection sequence for arbitrating systems as described in the CDC SCSI Specification section 5.1.3.2.

12.1.3.3 All Systems

Same as CDC SCSI specification section 5.1.3.3.

12.1.3.4 Single Initiator Option

WREN III HH supports a single Initiator system as described in the CDC SCSI Specification. section 5.1.3.4.

12.1.3.5 Selection Time Out Procedure

WREN III HH supports systems that implement the procedure as described in the CDC SCSI Specification section 5.1.3.5.

12.1.4 Reselection Phase

WREN III HH implements the reselection phase as described in the CDC Specification section 5.1.4 if the system is capable of supporting disconnection.

12.1.4.1 Reselection Procedure

Same as CDC SCSI Specification section 5.1.4.1.

12.1.4.2 Reselection Timeout Procedure

Same as CDC SCSI Specification section 5.1.4.2.

12.1.5 Information Transfer Phase

Same as CDC SCSI Specification. section 5.1.5.

12.1.5.1 Asynchronous Information Transfer

Same as CDC SCSI Specification section 5.1.5.1..

12.1.5.2 Synchronous Data Transfer

Not implemented in WREN III HH

12.1.6 Command Phase

Same as CDC SCSI Specification section 5.1.6.

12.1.7 Data Phase

Same as CDC SCSI Specification section 5.1.7.

12.1.7.1 Data In Phase

Same as CDC SCSI Specification section 5.1.7.1.

12.1.7.2 Data Out Phase

Same as CDC SCSI Specification section 5.1.7.2.

- 12.1.8 Status Phase
 - Same as CDC SCSI Specification section 5.1.8.
- 12.1.9 Message Phase
 - Same as CDC SCSI Specification section 5.1.9.
- 12.1.9.1 Message IN Phase
 - Same as CDC SCSI Specification section 5.1.9.1.
- 12.1.9.2 Message Out Phase
 - Same as CDC SCSI Specification section 5.1.9.2..
- 12.1.10 Signal Restrictions Between Phases
 - Same as CDC SCSI Specification section 5.1.10.
- 12.2 SCSI BUS CONDITIONS
 - Same as CDC SCSI Specification section 5.2.
- 12.2.1 Attention Condition
 - Same as CDC SCSI Specification section 5.2.1.
- 12.2.2 Reset Condition
 - Same as CDC SCSI Specification section 5.2.2. WREN III HH interprets the reset line. WREN III HH will never assert the reset line. WREN III HH will implement only the "hard" reset option.
- 12.3 SCSI BUS PHASE SEQUENCES
 - Same as CDC SCSI Specification section 5.3.
- 12.3.1 Nonarbitrating System
 - Same as CDC SCSI Specification section 5.3.1.
- 12.3.2 Arbitrating Systems
 - Same as CDC SCSI Specification section 5.3.2.

12.3.3 All Systems

Same as CDC SCSI Specification section 5.3.3.

12.4 SCSI POINTERS

WREN III HH supports systems which use the pointer philosophy described in the CDC SCSI specification section 5.4.

12.5 MESSAGE SYSTEM SPECIFICATION

Same as CDC SCSI Specification sections 5.1.9 and 5.5.

12.5.1 Message Protocol

Same as CDC SCSI Specification section 5.5.1. The WREN III HH supports systems that accommodate only the Command Complete message or systems that can accommodate additional messages. The WREN III HH is always logical unit (LUN) address zero.

12.5.2 Messages

WREN III HH supports the following messages described in the CDC SCSI Specification section 5.5.2. All other messages will be answered with a Message Reject message:

- Command Complete
- Extended Messages (Synchronous Data Transfer Request Only)
- Save Data Pointers
- Restore Pointers
- Disconnect
- Initiator Detected Error
- Abort
- Message Reject (WREN III HH will not resend (retry) the original message)
- No Operation
- Message Parity Error
- Bus Device Reset
- Identify

12.5.3 Extended Messages

Extended messages except for the Synchronous Data Transfer Request are not implemented. WREN III HH will respond with a Message Reject message after any other extended message is received.

12.5.4 Synchronous Data Transfer Request

WREN III HH will receive this message and respond with a REQ/ACK offset of zero which signifies that only the asynchronous protocol is implemented.

13.0 SCSI COMMANDS

Same as CDC SCSI Specification section 6.0; except WREN III HH does not support command linking. WREN III HH responds with a "Check Condition" status and "Illegal Request" sense key if a linked command is received.

13.1 COMMAND IMPLEMENTATION REQUIREMENTS.

Same as CDC SCSI Specification section 6.1.

13.1.1 Reserved

Same as CDC SCSI Specification section 6.1.1.

13.1.2 Operation Code Type

Not applicable

13.1.3 Unit Attention Condition

WREN III HH will support this condition when the WREN III HH has been reset by a power on sequence, internally generated resets (e.g. power glitch), a Bus Device Reset message or a "hard" Reset condition. WREN III HH implements this function as described in the CDC SCSI Specification section 6.1.3.

13.1.4 Command Queing

Same as in CDC SCSI Specification section 6.1-4. WREN III HH is capable of accepting and queuing one CDB per initiator for a maximum of 7 initiators.

13.2 COMMAND DESCRIPTOR BLOCK (CDB)

Same as CDC SCSI Specification section 6.2. See Format description in Tables 5a, 5b and 5c.

13.2.1 Operation Code

WREN III HH supports Group 0 (Six byte commands) and Group 1 (Ten byte commands) as described the CDC SCSI Specification section 6.2.1.

TABLE 5a. OPERATION CODE FORMAT FOR CDB
(Table 6-1 in CDC SCSI Spec)

BIT	7	6	5	4	3	2	1	0
BYTE(S)								
0	Group Code			Command Code				

TABLE 5b. TYPICAL COMMAND DESCRIPTOR BLOCK FOR SIX-BYTE COMMANDS
(Table 6-2 in CDC SCSI Spec)

BIT	7	6	5	4	3	2	1	0
BYTE(S)								
0	Operation Code							
1	Logical Unit No.			Logical Block Address (if req.) (MSB)				
	0	0	0					
2	Logical Block Address (if required)							
3	Logical Block Address (if required) (LSB)							
4	Transfer Length (if required)							
5	Control Byte							

TABLE 5c. TYPICAL COMMAND DESCRIPTOR BLOCK FOR TEN-BYTE COMMANDS
(Table 6-3 in CDC SCSI Spec)

BIT	7	6	5	4	3	2	1	0
BYTE(S)								
0	Operation Code							
1	Logical Unit No.			Reserved			RelAdr	
	0	0	0					0
2	Logical Block Address (if required) (MSB)							
3	Logical Block Address (if required)							
4	Logical Block Address (if required)							
5	Logical Block Address (if required) (LSB)							
6	Reserved							
7	Transfer Length (if required) (MSB)							
8	Transfer Length (if required) (LSB)							
9	Control Byte							

13.2.2 Logical Unit Number (LUN)

Same as CDC SCSI specification section 6.2.2. The only WREN III HH SCSI valid LUN is zero.

13.2.3 Logical Block Address

The maximum logical block address for WREN III HH which is accessible by the initiator is defined in Read Capacity Data in section 14.2.2.1.

13.2.4 Relative Address Bit

Not implemented. Must be zero.

13.2.5 Transfer Length

Same as CDC SCSI Specification section 6.2.5.

13.2.6 Control Byte

Must be all zeros. WREN III HH does not support the Flag and Link bit functions. These bits must be zero for the command to be accepted. If not, WREN III HH will send a "Check Condition" Status and a Sense Key of "Illegal Request". See Table 5d.

TABLE 5d. CONTROL BYTE
(Table 6-4 in CDC SCSI Spec)

BIT	7	6	5	4	3	2	1	0
BYTE(S)								
LAST	0	0	0	0	0	0	FLAG	LINK
							0	0

13.3 COMMAND EXAMPLES

13.3.1 Single Command Example

Same as CDC SCSI Specification section 6.3.1.

13.3.2 Disconnect Example

Same as CDC SCSI Specification section 6.3.2.

13.4 TIMING EXAMPLES

All CDC SCSI Specification section 6.4 Timing Diagrams are applicable. The WREN III HH times are Tabulated in Table 5e.

13.5 WREN III HH SCSI TIMING

TABLE 5e. WREN III HH SCSI TIMING

<u>DESCRIPTION</u>	<u>WAVEFORM SYMBOL</u>	<u>MIN</u>	<u>TYPICAL</u>	<u>MAX</u>
Target Select Time (no Arbitration)	T00		<125 μ s	<240 ms
Target Select Time (with Arbitration)	T01		<125 μ s	<240 ms
Target Select to Command	T02		<125 μ s	
Target Select to MSG Out	T03		< 75 μ s	
Identify MSG To Command	T04		<150 μ s	
Command to Status	T05		Command	Dependent
Command to Data (para. In)	T06		Command	Dependent
Command to Data (para. Out)	T07		Command	Dependent
Command to Data (Write to Data Buffer)	T08		<500 μ s	700 μ s
Command to Disconnect MSG	T09		<250 μ s	
Disconnect MSG to Bus Free	T10		< 75 μ s	
Disconnect to Arbitration (for Reselect). This measures disconnected CMD overhead	T11		Command	Dependent
Target win Arbitration (for Reselect)	T12		< 50 μ s	
Arbitration to Reselect	T13		< 50 μ s	
Reselect to Identify MSG In	T14		< 75 μ s	
Reselect Identify MSG to Status	T15		<100 μ s	
Reselect Identify MSG to Data (media)	T16		Command	Dependent
Data to Status	T17		Command	Dependent
Status to Command Complete MSG	T18		<100 μ s	
Command Complete MSG to Bus Free	T19		< 75 μ s	
Data to Save Data Pointer MSG	T20		<200 μ s	
Save Data Pointer MSG to Disconnect MSG	T21		<100 μ s	
Command Byte Transfer	T22		0.1 μ s	1 μ s
Next Command Byte Access	T23		20 μ s	75 μ s[1]
Data In Byte Transfer (parameter)	T24		0.1 μ s	1 μ s
Data Out Byte Transfer (parameter)	T25		0.1 μ s	1 μ s
Next Data In Byte Access (parameter)	T26		25 μ s	35 μ s

[1] For most bytes of the CDB T23 will be <20 μ s, but several bytes require a longer time due to decode overhead. A 6 byte CDB will require <225 μ s for five T23 occurrences. A 10 byte CDB will require <350 μ s for 9 occurrences.

TABLE 5e. WREN III HH SCSI TIMING (continued)

<u>DESCRIPTION</u>	<u>WAVEFORM SYMBOL</u>	<u>MIN</u>	<u>TYPICAL</u>	<u>MAX</u>
Next Data Out Byte Access (Parameter)	T27		22 μ s	35 μ s
Data In Byte Transfer (media)[2]	T28		40 ns	100 ns
Data Out Byte Transfer (media)[2]	T29		40 ns	100 ns
Next Data In Byte access (media)[2]	T30		400 ns	700 ns
Next Data Out Byte access (media)[2]	T31		300 ns	800 ns
MSG IN Byte Transfer	T32		0.1 μ s	1 μ s
MSG OUT Byte Transfer	T33		0.1 μ s	1 μ s
STATUS Byte Transfer	T34		0.1 μ s	1 μ s
Bad Message to Message Reject Message	T35		< 120 μ s	

[2] Maximum SCSI interface transfer rate is 1.25 MB/s. Therefore, the, minimum time between two leading edges of Request is 800 ns.

14.0 COMMAND DESCRIPTIONS

Two types of commands are supported by the WREN III HH: commands for all devices; and commands for direct access devices. In each of these categories the WREN III HH supports only Group 0 and Group 1 commands. Section 7.0 of the CDC SCSI Specification describes all the types and groups of commands. Use the tables in this specification to map the WREN III HH implementation into the tables in the CDC SCSI Specification which explains the general meanings of the commands.

14.1 COMMAND DESCRIPTIONS FOR ALL DEVICE TYPES

14.1.1 Group 0 Commands for All Device Types

The WREN III HH implements the following Group 0 commands which are applicable for all device types. See Table 6a.

TABLE 6a. GROUP 0 COMMANDS FOR ALL DEVICE TYPES

<u>COMMAND OP CODE*</u>	<u>COMMAND NAME</u>	<u>APPLICABLE SECTION</u>	<u>APPLICABLE CDC SCSI SECTION</u>
00H	Test Unit Ready	14.1.1.1	7.1.1
03H	Request Sense	14.1.1.2	7.1.2
12H	Inquiry	14.1.1.3	7.1.3
1CH	Receive Diagnostic Results	14.1.1.5	7.1.5
1DH	Send Diagnostic	14.1.1.6	7.1.6

*Byte 0 of Command Descriptor Block.

14.1.1.1 Test Unit Ready (00H)

Used to determine whether the logical unit is ready. Same as CDC SCSI Specification Section 7.1.1 except the Flag and Link bits must be zero. The only valid logical unit number for WREN III HH is zero. See Table 6b.

TABLE 6b. TEST UNIT READY COMMAND
(Table 7-2 in CDC SCSI Spec)

BIT	7	6	5	4	3	2	1	0
BYTE(S)								
0	0	0	0	0	0	0	0	0
1	LOGICAL UNIT NO.							
	0	0	0	0	0	0	0	0
2	0	0	0	0	0	0	0	0
3	0	0	0	0	0	0	0	0
4	0	0	0	0	0	0	0	0
5	0	0	0	0	0	0	FLAG	LINK
	0	0	0	0	0	0	0	0

14.1.1.2 Request Sense Command (03H)

The initiator requests sense data from a target via the Request Sense command. The target sends the sense data to the initiator in the data format described in Section 7.1.2 of the CDC SCSI Specification. The Request Sense command specifies in byte 4 of its CDB the number of bytes the initiator has allocated for returned sense data. (Allocation Length). The Allocation Length should always be at least 18 bytes for WREN III HH devices in order for the initiator to receive all of the WREN III HH sense data. If the allocation length is zero, the WREN III HH will return 4 bytes of sense data in extended sense data format. The Flag and Link bits in the Request Sense command must always be zero for WREN III HH.

The WREN III HH returns sense data in the extended sense data format. See Table 6c.

TABLE 6c. REQUEST SENSE COMMAND
(Table 7-3 in CDC SCSI Spec)

BIT BYTE(S)	7	6	5	4	3	2	1	0
0	0	0	0	0	0	0	1	1
1	LOGICAL UNIT NO.			0	0	0	0	0
2	0	0	0	0	0	0	0	0
3	0	0	0	0	0	0	0	0
4	ALLOCATION LENGTH IN BYTES							
5	0	0	0	0	0	0	FLAG	LINK
							0	0

Extended Sense Data Format

WREN III HH is capable of sending 18 bytes of extended sense data, and will send 18 bytes if the Allocation Length in the Request Sense Command is equal to or greater than 18 bytes (otherwise, the number of bytes specified by the Allocation Length will be sent). The Extended Sense Data Format is summarized in Table 7. Numbers in parentheses in the sense data are references to notes following the table. A "1" or a "0" means the data bit will always be logic 1 or logic 0, respectively, when sent by a WREN III HH.

TABLE 7. WREN III HH EXTENDED SENSE DATA SUMMARY
(Table 7-4 in CDC SCSI Spec)

BYTE	BIT	7	6	5	4	3	2	1	0
0	VALIDITY BIT (1)	1	1	1	0	0	0	0	0
		ERROR CLASS (2)						(3)	
1		0	0	0	0	0	0	0	0
		SEGMENT NUMBER (4)							
2	FILEMARK (5)	0	0	ILI (7)	0	SENSE KEY (8)			
3		INFORMATION BYTE (MSB) (9)							
4		:							
5		:							
6		INFORMATION BYTE (LSB) (9)							
7		ADDITIONAL SENSE LENGTH - Decimal 10 (Max) (10)							
8		Bytes 8 - 11 are Reserved for use by Copy or Search commands. Will be all zeros.							
9									
10									
11									
12		ERROR CODE (11)							
13		RESERVED (All Zeros)							
14		FRU CODE (12)							
15	FPV (13)	C/D (14)	0	0	BPV (16)	BIT POINTER (17)			
16		FIELD POINTER (MSB) (15)							
17		FIELD POINTER (LSB) (15)							
18-n		PRODUCT UNIQUE SENSE DATA (18)							

TABLE 7. WREN III HH EXTENDED SENSE DATA SUMMARY (continued)

NOTES:

Refer to CDC SCSI Specification section 7.1.2.1 for further details.

- (1) Validity Bit - "1" if the Information Bytes (Bytes 3-6) are valid, "0" if not valid.
- (2) Error Class - "111" (7) indicates Extended Sense is being used here.
- (3) "0000" specifies the Extended Sense data format. Byte 12 has error codes for Extended Sense.
- (4) Segment Number - Always zeros
- (5) Filemark - Always "0" for WREN III HH.
- (6) EOM - End Of Medium indicator. Always "0" for WREN III HH.
- (7) ILI - Incorrect Length Indicator. The requested (previous command) block of data did not match the logical block length of the data on the medium.
- (8) Sense Key - Indicates the general error categories. These are listed in Table 8. the code given in byte 12 provides additional clarification of errors. See also note 15 below for related information.
- (9) Information Byte - Contains unsigned logical block address associated with the error being reported.
- (10) Additional Length - Specifies additional sense bytes are to follow. This is limited to a maximum of 10 (decimal) additional bytes.
- (11) Error Code - Provides additional clarification of errors whenever Sense Key is valid. Error code definitions are in Table 9a.

TABLE 7. WREN III HH EXTENDED SENSE DATA SUMMARY (continued)

NOTES: (continued)

- (12) FRU (Field Replaceable Unit) Code - Defined for Field Maintenance personnel only.
- (13) FPV (Field Pointer Valid) bit - When set to one, indicates that the C/D bit and bytes 16 and 17 are valid. When zero, ignore these fields. Currently always zero.
- (14) C/D Bit - Command/Data bit, when set to one, indicates that the value reported in the field pointer bytes is the CDB's byte number for which an Illegal Request sense key was issued. When set to zero, it indicates that the value reported in the field pointer bytes is the byte number in the data phase for which an Illegal Request sense key was issued. See also Note 15.
- (15) Field Pointer (MSB) Refer to Table 7-5 of the CDC SCSI Field Pointer (LSB) Specification for details on the Illegal Request sense key description. The Illegal Request extended sense report uses the 16 bit Field Pointer to point to the first byte in a command descriptor block or associated data block where an illegal parameter was detected, causing the Illegal Request Sense Key.
- (16) BPV - Bit Pointer Valid bit, when set to one, indicates that the Bit Pointer Field is valid. Currently always zero.
- (17) Bit Pointer Field - Indicates which bit of the byte indicated by the Field Pointer caused the Illegal Request sense key. A value of 7 indicates the leftmost bit and zero indicates the rightmost bit.
- (18) Not presently used by the WREN III HH.

14.1.1.2 (continued)

Table 8 lists the sense keys in the extended sense data format that are used by the WREN III HH. Table 7-5 of the CDC SCSI Specification gives necessary details on the significance of these keys.

14.1.1.2 (continued)

TABLE 8. APPLICABLE WREN III HH SENSE KEYS
(Table 7-5 in CDC SCSI Spec)

<u>CODE</u>	<u>SENSE KEY</u>
00H	No Sense
01H	Recovered Error
02H	Not Ready
03H	Medium Error
04H	Hardware Error
05H	Illegal Request
06H	Unit Attention
0BH	Aborted Command
0DH	Volume Overflow
0EH	Data Mismatch

TABLE 9a. DIRECT ACCESS DEVICES, ADDITIONAL SENSE ERROR CODES
(Table 7-7a and b in CDC SCSI Spec)

<u>ERROR CODE</u>	<u>DESCRIPTION</u>	<u>MOST PROBABLE RELATED SENSE KEYS. OTHER SENSE KEYS MAY APPLY TO ADDITIONAL SENSE CODES.</u>
00	No additional information	No Sense
01	No Index/Address Mark Found signal	Hardware error
02	No Seek Complete	Hardware error
03	Write Fault	Hardware Error or Recovered Error
04	Drive not ready	Not Ready or Recovered Error
08	Logical Unit communication failure	Hardware error or Recovered Error
09	Track following error	Hardware error or Recovered Error
10	ID CRC or ECC error	Hardware Error or Medium error or Recovered Error
11	Unrecovered Read error	Medium error or Recovered error
12	No Address Mark (byte sync byte) found in ID field	Medium error or Recovered error
13	No Address Mark (byte sync byte) found in Data field	Medium error or Recovered error
14	No record found	Medium error or Recovered error
15	Seek positioning error	Hardware error or Medium error or Recovered error
17	Recovered Read data with target's Read retries (not with ECC)	Recovered error
18	Recovered Read data with target's ECC correction (not with retries)	Recovered error
19	Defect List error	Medium error
1C	Primary Defect List not found	Medium error
1D	Compare error	Mismatch error

14.1.1.2 (continued)

TABLE 9a. DIRECT ACCESS DEVICES, ADDITIONAL SENSE ERROR CODES
(continued)

ERROR CODE	DESCRIPTION	MOST PROBABLE RELATED SENSE KEYS. OTHER SENSE KEYS MAY APPLY TO ADDITIONAL SENSE CODES.
20	Invalid Command Operation Code	Illegal Request
21	Illegal Logical Block Address. Address greater than the LBA returned by the Read Capacity data with PMI bit not set in CDB.	Illegal Request
22	Illegal function for device type	Illegal Request
24	Illegal field in CDB	Illegal Request
25	Invalid LUN	Illegal Request
26	Invalid field in parameter list	Illegal Request
29	Power On or Reset or Bus Device Reset	Unit Attention
2A	Mode Select Parameters changed	Unit Attention
31	Medium Format corrupted	Medium error
32	No Defect Spare Location Available	Medium error
40	RAM failure	Hardware error
41	Data Path diagnostic failure	Hardware error
42	Power On Diagnostic failure	Hardware error
43	Message Reject error	Aborted Command
44	Internal Controller error	Hardware error or Not Ready or Recovered error
45	Select/Reselect failed	Aborted Command
47	SCSI Interface Parity error	Hardware error
48	Initiator Detected error	Aborted Command
49	Inappropriate/Illegal message	Aborted Command
80 thru FF	Product Unique Error Codes	

14.1.1.3 Inquiry Command (12H)

Implemented as described in the CDC SCSI Specification Section 7.1.3 with the following drive parameters:

Flag and Link bits must be zero. The initiator should allocate 36 bytes of inquiry data. The Inquiry command format is shown in Table 9b. Inquiry data is summarized in Table 10a and 10b.

TABLE 9b. INQUIRY COMMAND
(Table 7-11 in CDC SCSI Spec)

BIT	7	6	5	4	3	2	1	0
0	0	0	0	1	0	0	1	0
1	LOGICAL UNIT NO.			0	0	0	0	0
2	0	0	0	0	0	0	0	0
3	0	0	0	0	0	0	0	
4	ALLOCATION LENGTH IN BYTES							
5	0	0	0	0	0	0	FLAG	LINK
							0	0

Inquiry data may be returned even though the Wren III HH is not ready for other commands (i.e., prior to receiving a Start Unit command if the WREN III HH is configured to require a Start Unit command to start the spindle motor).

TABLE 10a. INQUIRY DATA SUMMARY
(Table 7-12 in CDC SCSI Spec)

BIT	7	6	5	4	3	2	1	0
0	DEVICE TYPE (00H) or (7FH) LUN NOT PRESENT							
1	RMB 0	DEVICE-TYPE QUALIFIER (00H)						
2	ISO VERSION (0H)		ECMA VERSION (0H)			ANSI VERSION (1H)		
3	0	0	0	0	RESPONSE DATA FORMAT (1H) [2]			
4	ADDITIONAL LENGTH (n) (1FH)							

COMMON COMMAND SET PARAMETERS

5	REQUEST SENSE DATA LENGTH (12H)							
6	CDC RESERVED (00H)							
7	CDC RESERVED (00H)							
8	VENDOR IDENTIFICATION: ASCII 'C' (43H)							[3]
9	VENDOR IDENTIFICATION: ASCII 'D' (44H)							
10	VENDOR IDENTIFICATION: ASCII 'C' (43H)							
11	VENDOR IDENTIFICATION: ASCII "BLANK" (20H)							
12	VENDOR IDENTIFICATION: ASCII "BLANK" (20H)							
13	VENDOR IDENTIFICATION: ASCII "BLANK" (20H)							
14	VENDOR IDENTIFICATION: ASCII "BLANK" (20H)							
15	VENDOR IDENTIFICATION: ASCII "BLANK" (20H)							
16	PRODUCT IDENTIFICATION: ASCII '9' (39H)							
17	PRODUCT IDENTIFICATION: ASCII '4' (34H)							
18	PRODUCT IDENTIFICATION: ASCII '2' (32H)							
19	PRODUCT IDENTIFICATION: ASCII '1' (31H)							
20	PRODUCT IDENTIFICATION: ASCII '1' (31H)							
21	PRODUCT IDENTIFICATION: ASCII '-' (2DH)							
22	PRODUCT IDENTIFICATION: ASCII [1]							
23	PRODUCT IDENTIFICATION: ASCII "BLANK" (20H)							
24	PRODUCT IDENTIFICATION: ASCII "BLANK" (20H)							
25	PRODUCT IDENTIFICATION: ASCII "BLANK" (20H)							
26	PRODUCT IDENTIFICATION: ASCII "BLANK" (20H)							
27	PRODUCT IDENTIFICATION: ASCII "BLANK" (20H)							
28	PRODUCT IDENTIFICATION: ASCII "BLANK" (20H)							
29	PRODUCT IDENTIFICATION: ASCII "BLANK" (20H)							
30	PRODUCT IDENTIFICATION: ASCII "BLANK" (20H)							
31	PRODUCT IDENTIFICATION: ASCII "BLANK" (20H)							
32	REVISION LEVEL: ASCII DRIVE REVISION NO.							
33	REVISION LEVEL: ASCII DRIVE REVISION NO.							
34	REVISION LEVEL: ASCII DRIVE REVISION NO.							
35	REVISION LEVEL: ASCII DRIVE REVISION NO.							

[1] The dash number representing the drive configuration is given in Table 10b.

TABLE 10b. INQUIRY DATA BYTES 22-26, DRIVE MODEL DASH NUMBER

<u>BYTE</u>	<u>22</u>	<u>DRIVE CONFIGURATION</u>
	5	5 Headed Drive

[2] Common Command set format used.

[3] ASCII Data fields shall have most significant byte returned first, with no leading spaces. ASCII fields are to be returned in the order in which they are to be read.

14.1.1.4 Copy Command (18H)

Not Implemented. If received the WREN III HH will send a "Check Condition" status and a sense key of "Illegal Request".

14.1.1.4.1 through 14.1.1.4.5 - Correspond to CDC SCSI specification paragraphs 7.1.4.1 through 7.1.4.5 which are not applicable to WREN III HH.

14.1.1.5 Receive Diagnostic Results Command (1CH)

Implemented as described in the CDC SCSI Specification section 7.1.5 with the following WREN III HH parameters:

The CDB should be as shown in Figure 11a. The Flag and Link bits in the CDB must be zero.

WREN III HH is capable of sending 40 Diagnostic Data Bytes as shown in Table 11b. All FRU and error code definitions are unique to this product and intended for CDC Factory/Field Maintenance personnel.

TABLE 11a. RECEIVE DIAGNOSTIC RESULTS COMMAND
(Table 7-23 in CDC SCSI Spec)

BIT	7	6	5	4	3	2	1	0
0	0	0	0	1	1	1	0	0
1	LOGICAL UNIT NO.			0	0	0	0	0
2	0	0	0	0	0	0	0	0
3	ALLOCATION LENGTH IN BYTES (MSB)							
4	ALLOCATION LENGTH IN BYTES (LSB)							
5	0	0	0	0	0	0	FLAG	LINK
							0	0

TABLE 11b. CDC DIAGNOSTIC DATA BYTES
(Table 7-24 in CDC SCSI Spec)

<u>CODE</u>	<u>BYTE</u>	<u>DESCRIPTION</u>
00H	0	Additional Length (MSB)
26H	1	Additional Length (LSB)
00H	2	FRU Code (most probable)
00H	3	FRU Code
00H	4	FRU Code
00H	5	FRU Code (least probable)
00H	6	Error Code (MSB)
V.U.*	7	Error Code (LSB)
V.U.	8-39	Vendor Unique Data

Additional Length:

This two byte value indicates the number of additional bytes included in the diagnostic data list. For example, if no product unique bytes were available, this value would be 0006H. A value of 0000H means that there are no additional bytes. Normally this value is 26H.

FRU Code:

A Field Replaceable Unit code is a byte that identifies an assembly that may have failed. The codes will be listed in probability order, with the most probable assembly listed first and the least probable listed last. A code of 00H indicates that there is no FRU information and a code of 01H indicates that the entire unit should be replaced. Other values have product unique meanings.

Error Code:

This two byte value provides information about what part of a diagnostic operation has failed. The byte 7 error code is vendor unique and defined as follows:

* Vendor Unique Diagnostic Fault Codes

01H	Sequencer Diagnostic Error
02H	External RAM Diagnostic Error
04H	No Drive Ready
08H	No Sector or Index Detected
09H	Fatal Hardware Error While Doing Drive Diagnostics
0CH	No Drive Command Complete
10H	Unable to Set Drive Sector Size
14H	Unable to Clear Drive Attention
18H	Unable to Start Spindle Motor
20H	Unable to Recal Drive
30H	Unable to Send Write Current Data to Drive
34H	Unable to Issue Drive Seek Command
40H	Unable to Read User Table From Drive
41H	Ran Out of Sectors While Doing Drive Diagnostics
80H	DMA Chip Diagnostic Error
81H	Buffer RAM Diagnostic Error
0C1H	Data Miscompare While Doing Drive Diagnostics
0EOH	Unable to read ETF Log

14.1.1.6 Send Diagnostic Command (1DH)

Implemented per the CDC SCSI Specification section 7.1.6 with the drive interpretations given in Table 11c.

TABLE 11c. CDB REQUIREMENTS FOR SEND DIAGNOSTIC COMMAND
(Table 7-25 in CDC SCSI Spec)

BIT BYTE(S)	7	6	5	4	3	2	1	0
0	0	0	0	1	1	1	0	1
1	LOGICAL UNIT NO.					SELF-TEST	DEV-OFL	UNIT OFL
	0	0	0	0	0	1		
2	0	0	0	0	0	0	0	0
3	PARAMETER LIST LENGTH (MSB)							
	0	0	0	0	0	0	0	0
4	PARAMETER LIST LENGTH (LSB)							
	0	0	0	0	0	0	0	0
5							FLAG	LINK
	0	0	0	0	0	0	0	0

WREN III HH performs only its default self test. This will include seeking to a reserved nonuser accessible cylinder, then writing, reading and verifying data for each data surface.

For systems which support disconnection, WREN III HH will disconnect while executing this command.

14.1.2 GROUP 1 COMMANDS FOR ALL DEVICE TYPES

WREN III HH implements the following commands which are applicable for all device types.

<u>OP CODE</u>	<u>COMMAND NAME</u>	<u>SECTION</u>
3BH	Write Data Buffer	14.1.2.3
3CH	Read Data Buffer	14.1.2.4

14.1.2.1 Compare Command (39H)

Not Implemented

14.1.2.2 Copy and Verify Command (3AH)

Not Implemented

14.1.2.3 Write Data Buffer Command (3BH)

Implemented as described in the CDC SCSI Specification section 7.2.3 with a maximum data buffer size of 8,192 bytes. Writing will be initiated at "Byte Number 0" of the WREN III HH data buffer.

TABLE 12a. WRITE DATA BUFFER COMMAND
(Table 7-27 in CDC SCSI Spec)

BIT BYTE(S)	7	6	5	4	3	2	1	0
0	0	0	1	1	1	0	1	1
1	LOGIC UNIT NO.							
	0	0	0	0	0	0	0	0
2	0	0	0	0	0	0	0	0
3	0	0	0	0	0	0	0	0
4	0	0	0	0	0	0	0	0
5	0	0	0	0	0	0	0	0
6	0	0	0	0	0	0	0	0
7	BYTE TRANSFER LENGTH (MSB) [1]							
8	BYTE TRANSFER LENGTH (LSB) [1]							
9	0	0	0	0	0	0	FLAG	LINK
							0	0

[1] Equal to or less than 8,196 bytes (includes a 4 byte header).

14.1.2.3 continued

The write data following the write data buffer CDB consists of a 4 byte write data buffer header (which always precedes the data) plus the data to be written to the data buffer as follows:

TABLE 12b. WRITE DATA BUFFER HEADER
(Table 7-28 in CDC SCSI Spec)

BIT	7	6	5	4	3	2	1	0
0	0	0	0	0	0	0	0	0
1	0	0	0	0	0	0	0	0
2	0	0	0	0	0	0	0	0
3	0	0	0	0	0	0	0	0
4 - n	DATA TO BE WRITTEN INTO WREN III HH BUFFER							

14.1.2.4 Read Data Buffer Command (3CH)

Implemented as described in the CDC SCSI Specification section 7.2.4 with the following WREN III HH parameters (Table 12c):

TABLE 12c. READ DATA BUFFER CDB PARAMETERS
(Table 7-29 in CDC SCSI Spec)

BIT BYTE(S)	7	6	5	4	3	2	1	0
0	0	0	1	1	1	1	0	0
1	LOGICAL UNIT NO.							
	0	0	0	0	0	0	0	0
2	0	0	0	0	0	0	0	0
3	0	0	0	0	0	0	0	0
4	0	0	0	0	0	0	0	0
5	0	0	0	0	0	0	0	0
6	0	0	0	0	0	0	0	0
7	ALLOCATION LENGTH (MSB) [1]							
8	ALLOCATION LENGTH (LSB) [1]							
9	0	0	0	0	0	0	FLAG	LINK
							0	0

[1] Should be 8,196 decimal in order read the drive's entire buffer plus the 4 byte read data buffer header.

14.1.2.4 continued

TABLE 12d. READ DATA BUFFER HEADER
(Table 7-30 in CDC SCSI Spec)

BIT BYTES	7	6	5	4	3	2	1	0
0	0	0	0	0	0	0	0	0
1	0	0	0	0	0	0	0	0
2	AVAILABLE LENGTH (MSB)				[2]			
3	AVAILABLE LENGTH (LSB)				[2]			
4-n	BUFFER DATA BYTES							

[2] 8,192 Bytes

Reading will be initiated from "Byte Number 0" of the WREN III HH data buffer. The drive will not attempt to detect whether buffer data has been changed between Write and Read Data Buffer commands.

14.1.3 Group 2 through 5 commands for all device types. Corresponds to paragraphs 7.3 - 7.6 of CDC SCSI specification. Not implemented. A "Check Condition" status will be sent if any of these commands are received.

14.1.4 GROUP 6 Commands for All Device Types

Reserved for CDC usage. Customers should not attempt to use these functions. If issued the user's stored data may be destroyed.

14.1.5 GROUP 7 Commands for All Device Types

Same as Group 6 Commands.

14.2 COMMAND DESCRIPTIONS FOR DIRECT ACCESS DEVICES

The WREN III HH supports Group 0, and Group 1 commands for Direct Access Devices. Refer to CDC SCSI specification section 8.0 for more details on these commands.

14.2.1 GROUP 0 COMMANDS FOR DIRECT ACCESS DEVICES

The Group 0 Commands implemented by WREN III HH are listed in Table 13. (CDC SCSI Specification Table 8.1)

TABLE 13. GROUP 0 COMMANDS IMPLEMENTED

<u>OPERATION CODE (HEX)</u>	<u>COMMAND NAME</u>	<u>SECTION</u>
00	TEST UNIT READY	14.1.1.1
01	REZERO UNIT	14.2.1.1
03	REQUEST SENSE	14.1.1.2
04	FORMAT UNIT	14.2.1.2
07	REASSIGN BLOCKS	14.2.1.3
08	READ	14.2.1.4
0A	WRITE	14.2.1.5
0B	SEEK	14.2.1.6
12	INQUIRY	14.1.1.3
15	MODE SELECT	14.2.1.7
16	RESERVE	14.2.1.8
17	RELEASE	14.2.1.9
1A	MODE SENSE	14.2.1.10
1B	START/STOP UNIT	14.2.1.11
1C	RECEIVE DIAGNOSTIC RESULTS	14.1.1.5
1D	SEND DIAGNOSTIC	14.1.1.6

14.2.1.1 Rezero Unit Command (01H)

Implemented as described in the CDC SCSI Specification section 8.1.1 for a LUN of zero and Flag and Link bits of zero.

For systems that support disconnection, WREN III HH will disconnect when this command is received. See Table 14a.

TABLE 14a. REZERO UNIT COMMAND CDB SPECIFICATION
(Table 8.2 in CDC SCSI Spec)

BIT BYTES	7	6	5	4	3	2	1	0
0	0	0	0	0	0	0	0	1
1	LOGICAL UNIT NO.							
	0	0	0	0	0	0	0	0
2	0	0	0	0	0	0	0	0
3	0	0	0	0	0	0	0	0
4	0	0	0	0	0	0	0	0
5	0	0	0	0	0	0	FLAG 0	LINK 0

14.2.1.2 Format Unit Command (04H)

Implemented as described in the CDC SCSI Specification section 8.1.2, for a LUN of zero, mandatory features and a subset of the available optional features as defined in the following paragraphs.

WREN III HH allows an initiator to specify (or not specify) sectors which are to be reallocated during the Format process. The format parameters to be specified in the Format Unit command are defined in Table 14b.

TABLE 14b. FORMAT UNIT COMMAND CDB SPECIFICATION
(Table 8-3 in CDC SCSI Spec)

BIT BYTE(S)	7	6	5	4	3	2	1	0
0	0	0	0	0	0	1	0	0
1	LOGICAL UNIT NO.			FMT DATA	CMP- LIST	DEFECT LIST FORMAT		
	0	0	0	[1]	[1]	[1]		
2	0	0	0	0	0	0	0	0
3	INTERLEAVE (MSB)							
4	INTERLEAVE (LSB) (a value of 0000H defaults to an interleave of 1)							
5	0	0	0	0	0	0	0	0

[1] See Table 15 for details of values used here and their meanings.

14.2.1.2 (continued)

The definitions of flaw categories listed below are needed to help in understanding the alternatives listed in Table 15.

- P = Primary Defect Type: P type flawed sectors are identified in a list of defects (permanent flaws) supplied by CDC and stored on the disk at the time of shipment, in an area that is not directly accessible by the user. (This list may also be referred to as an ETF List). This defect list will not be modified or changed by WREN III HH (or Host Initiator) after shipment.
- C = Certification Defect Type: C type flawed sectors are sectors which fail an automatic format verify during the format function.
- D = Data Defect Type: D type sectors are sectors identified in a list supplied to the target by the initiator during a Data Out Phase of the current Format Unit command. The D List follows a four byte defect list header and is referred to as Defect Descriptor Bytes.
- G = Growth Defect Type: G type flawed sectors contain medium flaws and have been reallocated as a result of receiving a Reassign Blocks command, or certification defects (C type) reallocated during a previous Format Unit command, or data defects (D type) reallocated during a previous Format Unit command. This G list is recorded on the WREN III HH media and may be referenced for the current (and subsequent) Format Unit commands. This (G) list does not include the Primary (P) list of defects.

14.2.1.2 (continued)

TABLE 15. FORMAT UNIT PARAMETER DEFINITION (FORMAT VARIATIONS)
(Table 8-4 in CDC SCSI Spec)

CDB-Byte 1				COMMENTS
Bits [1]				
4	3	2	1 0	
FMT	CMP	DEFECT		
DATA	LIST	LIST	LIST	
		FORMAT		
0	X	X X X		Default Format: No Data Out phase occurs. WREN III HH will reallocate all sectors in the P list plus any sector which fails the format verify phase (C type flaws). Any previous G list will be erased:
1	0	0 X X		Format with G and no D: A four byte Defect List Header must be sent by the initiator. No Defect Descriptors (D list) are sent by the initiator. WREN III HH will reallocate all sectors in the drives current G list. See also note [2].
1	1	0 X X		Format without G or D: A four byte Defect List Header must be sent by the initiator. No D List may be sent by the initiator. WREN III HH will erase any previous G, D or C list. See also note [2].
1	1	1 0 0		Format with D and without G: The initiator must send a four byte Defect List Header followed by a D list of defects that WREN III will reallocate. The D list must be in the Bytes from Index format (see CDC SCSI Spec Table 8-6). WREN III will erase any previously existing G list. See note [2].
1	1	1 0 1		Format with D and without G: The initiator must send a four byte Defect List Header followed by a D List of defects that WREN III HH will reallocate. The D list must be in the Physical Sector format (see CDC Spec Table 8-7). WREN III HH will erase any previous G list. See also note [2].

[1] Refer to Table 8-4 in CDC SCSI Specification.

[2] Byte one of the Defect List Header determines whether the P and C defects are reallocated. See Table 16.

14.2.1.2 (continued)

TABLE 16a. DEFECT LIST HEADER (4 Bytes)
(Table 8-5 in CDC SCSI Spec)

BIT BYTE(S)	7	6	5	4	3	2	1	0
0	0	0	0	0	0	0	0	0
1	FOV [1]	DPRY [2]	DCRT [3]	STPF [4]	0	0	0	0
2	DEFECT LIST LENGTH (MSB)						[5]	
3	DEFECT LIST LENGTH (LSB)						[5]	
DEFECT DESCRIPTORS								
0-n	DEFECT DESCRIPTOR BYTES (Refer to Table 16b and 16c for Format)							

NOTES: See page 82 for definition of notes.

TABLE 16b. DEFECT DESCRIPTOR BYTES - BYTES FROM INDEX FORMAT
(Table 8-6 in CDC SCSI Spec)

0	Cylinder Number of Defect (MSB)
1	Cylinder Number of Defect
2	Cylinder Number of Defect (LSB)
3	Head Number of Defect
4	Defect Bytes from Index (MSB)
5	Defect Bytes from Index
6	Defect Bytes from Index
7	Defect Bytes from Index (LSB)

Information in this table is repeated for each defect.

14.2.1.2 (continued)

TABLE 16c. DEFECT DESCRIPTOR BYTES - PHYSICAL SECTOR FORMAT
 (Table 8-7 in CDC SCSI Spec)

0	Cylinder Number of Defect (MSB)
1	Cylinder Number of Defect
2	Cylinder Number of Defect (LSB)
3	Head Number of Defect
4	Defect Sector Number (MSB)
5	Defect Sector Number
6	Defect Sector Number
7	Defect Sector Number (LSB)

Information in this table is repeated for each defect.

14.2.1.2 (continued)

NOTES FOR TABLE 16a. DEFECT LIST HEADER BIT INTERPRETATIONS.

<u>FUNCTION</u>	<u>WREN III INTERPRETATION</u>
[1] FOV	If one, WREN III HH interprets the DPROY, DCRT and STFP bits. If zero, WREN III HH does not interpret the DPROY, DCRT and STFP bits.
[2] DPROY	If one, flaws in the WREN III HH P list will not be reallocated during formatting. This means existing reallocations of the P list will be wiped out and no new reallocations made during formatting. The P list is still retained. If zero, flaws in the WREN III HH P list will be reallocated during formatting. A check condition shall be sent in the status if the P list cannot be found by the WREN III HH.
[3] DCRT	If one, WREN III HH will not perform a verify function during formatting (thus no C list for this format will be created or reallocated). If zero, WREN III HH will perform a verify function during formatting and will reallocate any sector which fails the verify (i.e.; a C list will be created and these flaws reallocated).
[4] STPF	If one, formatting will be terminated if an error is encountered in accessing either the P or G defect list. If zero, formatting will not be terminated if an error is encountered in accessing either the P or G defect list.
[5] DEFECT LIST LENGTH	The length of any following D list (Defect Descriptors) must equal to 8 times the number of sectors to be reallocated per Table 16b or 16c.

NOTE: The initiator may not use any previously defined "C", "G", or "D" lists if the sector size (block length) has been changed.

For systems that support disconnection, WREN III HH will disconnect while executing the Format Unit command.

14.2.1.3 Reassign Blocks Command (07H)

Implemented as described in the CDC SCSI Specification section 8.1.3 with the following WREN III HH parameters. Refer to figures 16d and 16e.

The Logical Unit Address specified in the CDB must be zero. The Flag and Link bits specified in the CDB must be zero.

This command should be used by an initiator to immediately reallocate any block (sector) which requires the WREN III HH to recover data by data correction via ECC.

For systems which support disconnection, WREN III HH will disconnect while executing this command.

TABLE 16d. REASSIGN BLOCKS COMMAND
(Table 8-9 in CDC SCSI Spec)

BIT BYTE(S)	7	6	5	4	3	2	1	0
0	0	0	0	0	0	1	1	1
1	LOGICAL UNIT NO.							
	0	0	0	0	0	0	0	0
2	0	0	0	0	0	0	0	0
3	0	0	0	0	0	0	0	0
4	0	0	0	0	0	0	0	0
5	0	0	0	0	0	0	FLAG	LINK
							0	0

After sending the Reassign Blocks command, the initiator transfers a defect list that contains the Logical block addresses to be reassigned. The format is shown in Table 16e.

14.2.1.3 continued

TABLE 16e. REASSIGN BLOCKS DEFECT LIST
(Table 8-10 in CDC SCSI Spec)

DEFECT LIST HEADER									
BYTES	7	6	5	4	3	2	1	0	
0	0	0	0	0	0	0	0	0	0
1	0	0	0	0	0	0	0	0	0
2	DEFECT LIST LENGTH (MSB)								
3	DEFECT LIST LENGTH (LSB)								
DEFECT DESCRIPTOR(S)									
0	DEFECT LOGICAL BLOCK ADDRESS (MSB)								
1	DEFECT LOGICAL BLOCK ADDRESS								
2	DEFECT LOGICAL BLOCK ADDRESS								
3	DEFECT LOGICAL BLOCK ADDRESS (LSB)								

14.2.1.4 Read Command (08H)

Implemented as described in the CDC SCSI Specification section 8.1.4 with the following WREN III HH parameters. See Table 16e.

TABLE 16f. READ COMMAND
(Table 8-11 in CDC SCSI Spec)

BIT	7	6	5	4	3	2	1	0	
0	0	0	0	0	1	0	0	0	
1	LOGICAL UNIT NO.			LOGICAL BLOCK ADDRESS (MSB)					
	0	0	0						
2	LOGICAL BLOCK ADDRESS								
3	LOGICAL BLOCK ADDRESS (LSB)								
4	TRANSFER LENGTH								
5	0	0	0	0	0	0	0	0	0
							FLAG	LINK	
							0	0	

14.2.1.4 continued

In the CDB the LUN must be zero and the Flag and Link bits must be zero.

Read data transfers with the initiator will not be initiated until at least one full sector of data is available in the WREN III HH data buffer. For multiple sector reads, the transfer of data will continue until the number of blocks specified in byte 4 of the CDB has been read and transferred or until an unrecoverable error is detected.

Data transfer could stop if the option to stop on recovered error is selected.

For systems which support disconnection, WREN III HH will disconnect when a valid Read command is received by the WREN III HH. WREN III HH will reconnect when data is available to be transferred to the initiator. After data transfer has been initiated with an initiator, the WREN III HH will not disconnect unless an internal error recovery procedure is required or the data transfer to an initiator will be interrupted for more than 1 millisecond.

The initiator must accept all data presented to the initiator after sending this command until the WREN III HH sends Completion Status during a Status phase. (Note the WREN III HH may disconnect and reconnect while executing this command and the initiator may prematurely terminate this command by creating the Reset condition or by sending an Abort or Bus Device Reset message).

Sense Data will always be valid after this command is executed and Completion status is sent. If the Address Valid bit in the Sense Data is true (1), the Sense Data Logical Block Address (Information bytes) will point to the last Logical Block accessed by the WREN III HH. If the Address Valid bit in the Sense Data is false (0), then the Sense Data Logical Block Address bytes are not valid.

14.2.1.5 Write Command (OAH)

WREN III HH implements this command with the following drive parameters. See Table 16g.

TABLE 16g. WRITE COMMAND
(Table 8-12 in CDC SCSI Spec)

BIT	7	6	5	4	3	2	1	0
0	0	0	0	0	1	0	1	0
1	LOGICAL UNIT NO.			LOGICAL BLOCK ADDRESS (MSB)				
	0	0	0					
2	LOGICAL BLOCK ADDRESS							
3	LOGICAL BLOCK ADDRESS (LSB)							
4	TRANSFER LENGTH							
5	0	0	0	0	0	0	FLAG	LINK
							0	0

In the CDB the LUN must be zero and the Flag and Link bits must be zero.

For a valid Write command WREN III HH initiates requests for write data before disconnecting and before initiating any required seek function specified for this command.

For Systems which support disconnection, WREN III HH will disconnect when any internal error recovery procedure is required or the data transfer with the initiator will be interrupted for more than 1 millisecond.

The initiator must send requested write data to the drive until the drive sends Completion status during a Status phase or until the initiator Resets/Aborts the command. (Note: the drive may disconnect and reconnect while executing this command).

Sense Data will always be valid after this command is executed and Completion status is sent. (refer to the Read command description in Section 14.2.1.4).

14.2.1.6 Seek Command (OBH)

Implemented as described in the CDC SCSI Specification section 8.1.6 for a CDB LUN of zero and Flag and Link bits zero. See Table 16h.

TABLE 16h. SEEK COMMAND
(Table 8-13 in CDC SCSI Spec)

BIT BYTE(S)	7	6	5	4	3	2	1	0
0	0	0	0	0	1	0	1	1
1	LOGICAL UNIT NO.			LOGICAL BLOCK ADDRESS (MSB)				
	0	0	0					
2	LOGICAL BLOCK ADDRESS							
3	LOGICAL BLOCK ADDRESS (LSB)							
4	0	0	0	0	0	0	0	0
5	0	0	0	0	0	0	FLAG	LINK
							0	0

The use of this command is infrequent since most commands involving data transfer to/from the WREN III HH media contain implied seek addresses.

For systems which support disconnection, the WREN III HH will disconnect when a valid Seek command is received.

The maximum Logical Block Address which may be specified for a Seek command is defined in Read Capacity Data (section 14.2.2.1).

14.2.1.7 Mode Select Command (15H)

The WREN III HH implements this command as described in the CDC SCSI Specification section 8.1.7 with the following WREN III HH parameters (see Table 17a):

TABLE 17a. MODE SELECT COMMAND
(Table 8-14 in CDC SCSI Spec)

BIT BYTE(S)	7	6	5	4	3	2	1	0	
0	0	0	0	1	0	1	0	1	
1	LOGICAL UNIT NO.			PF				SMP	
	0	0	0	[2]	0	0	0	[3]	
2	0	0	0	0	0	0	0	0	
3	0	0	0	0	0	0	0	0	
4	PARAMETER LIST LENGTH							[1]	
5	0	0	0	0	0	0	FLAG	LINK	
							0	0	

In the CDB the LUN must be zero and the Flag and Link bits must be zero.

- [1] See Parameter List Function, Length and Changeable Status Table following this table.
- [2] Don't care; can be zero or one.
- [3] The SMP (Save Mode Parameters) bit may be either 0 or 1.

14.2.1.7 (continued)

An initiator may implement the procedure defined in section 8.1.7 of the CDC specification which uses the Mode Sense command to determine the number of applicable Block Descriptors, the number and length of Mode Sense/Mode Select Pages supported plus the parameters which may be modified by an Initiator. Detailed descriptions of these parameters are defined in the Mode Sense command (Section 14.2.1.10) and summarized below:

FUNCTION	NUMBER OF BYTES CHANGEABLE BY AN (Decimal) [1]	INITIATOR
Mode Select Header	4	NO
Block Descriptor	8 (or zero)	SOME
Error Recovery Page Header	2	NO
Error Recovery Page Parameters	6	SOME
Disconnect/Reconnect Page Header	2	NO
Disconnect/Reconnect Parameters	10	NO
Format Page Header	2	NO
Format Page Parameters	22	NO
Rigid Disk Drive Geometry Header	2	NO
Rigid Disk Drive Geometry Parameters	18	NO

[1] Derive Parameter List Length in Table 17a from these numbers.

An initiator should not send more (or less, except zero) Mode Select Data than specified in the above summarized table.

14.2.1.7 (continued)

Acceptable contents of the Mode Select Parameter List for the WREN III HH listed in Table 17b.

TABLE 17b. MODE SELECT PARAMETER LIST
(Table 8-15 in CDC SCSI Spec)

BIT BYTE(S)	7	6	5	4	3	2	1	0
	RESERVED							
0	0	0	0	0	0	0	0	0
1	MEDIUM TYPE							
	0	0	0	0	0	0	0	0
2	RESERVED							
	0	0	0	0	0	0	0	0
3	BLOCK DESCRIPTOR LENGTH EITHER 0 OR 8 (DECIMAL)							
BLOCK DESCRIPTOR								
0	DENSITY CODE							
	0	0	0	0	0	0	0	0
1	NUMBER OF BLOCKS (MSB)							
	0	0	0	0	0	0	0	0
2	NUMBER OF BLOCKS							
	0	0	0	0	0	0	0	0
3	NUMBER OF BLOCKS (LSB)							
	0	0	0	0	0	0	0	0 [1]
4	0	0	0	0	0	0	0	0
5	BLOCK LENGTH (MSB)							
6	BLOCK LENGTH [2]							
7	BLOCK LENGTH (LSB)							
PARAMETER INFORMATION								[3]
8 - n	MODE SELECT PAGE HEADERS AND THEIR PARAMETERS (TABLE 17c)							

- NOTES:
- [1] All zeros to signify only one block size for the entire LUN.
 - [2] Any block length between 256 and 2048 prior to a Format to set desired sector size.
 - [3] See Mode Sense command.

TABLE 17c. MODE SELECT PAGE DESCRIPTOR HEADER
(Table 8-16 in CDC SCSI Spec)

BIT	7	6	5	4	3	2	1	0
BYTE(S)								
0	0	0	PAGE CODE					
1	PAGE LENGTH							
2-n	MODE PARAMETERS							

14.2.1.8 RESERVE Command (16H)

Implemented as described in the CDC SCSI Specification section 8.1.8 for an Entire Unit Reserve with Third Party Reserve supported and with the WREN III HH specific parameters shown in Table 18a.

TABLE 18a. RESERVE COMMAND CDB SETUP
(Table 8-17 in CDC SCSI Spec)

BIT	7	6	5	4	3	2	1	0
BYTE(S)								
0	0	0	0	1	0	1	1	0
1	LOGICAL UNIT NO.		3rd PRTY	3rd PRTY DEV. ID			EXTENT	
	0	0	0	0 or 1	[1]		0	
2	RESERVATION IDENTIFICATION							
	0	0	0	0	0	0	0	0
3	EXTENT LIST LENGTH (MSB)							
	0	0	0	0	0	0	0	0
4	EXTENT LIST LENGTH (LSB)							
	0	0	0	0	0	0	0	0
5							FLAG	LINK
	0	0	0	0	0	0	0	0

[1] If Bit 4 is zero, Bits 3, 2, and 1 are zeros. If Bit 4 is one, Bits 3, 2, and 1 identify the SCSI device ID for which the drive is to be reserved..

14.2.1.8.1 Logical Unit Reservation

Same as CDC SCSI Specification section 8.1.8.1 for an Extent Bit equal zero.

14.2.1.8.2 Extent Reservation

Same as CDC SCSI Specification section 8.1.8.2 - Not supported

14.2.1.8.3 Third Party Reservation

Same as CDC SCSI Specification section 8.1.8.3.

14.2.1.8.4 Superceding Reservations

Same as CDC Specification section 8.1.8.4.

14.2.1.9 Release Command (17H)

Implemented as described in the CDC SCSI Specification section 8.1.9 for an Entire Unit Release and Third Party Release supported with the following WREN III HH specific parameters. (See Table 18b).

In the CDB the LUN must be zero, and the Extent, Flag and Link bits must be zero.

TABLE 18b. RELEASE COMMAND
(Table 8-18 in CDC SCSI Spec)

BIT BYTE(S)	7	6	5	4	3	2	1	0
0	0	0	0	1	0	1	1	1
1	LOGICAL UNIT NO.		3rd PRTY	THIRD PRTY DEV. ID.		EXTENT		0
	0	0	0	[1]				0
2	RESERVATION IDENTIFICATION							
	0	0	0	0	0	0	0	0
3	EXTENT LIST LENGTH (MSB)							
	0	0	0	0	0	0	0	0
4	EXTENT LIST LENGTH (LSB)							
	0	0	0	0	0	0	0	0
5							FLAG	LINK
	0	0	0	0	0	0	0	0

[1] Same as Note 1 for Reserve command, section 14.2.1.8.

14.2.1.9.1 Logical Unit Release

Same as CDC SCSI Specification section 8.1.9.1.

14.2.1.9.2 Extent Release

Same as CDC SCSI Specification (not supported).

14.2.1.9.3 Third Party Release

Same as CDC SCSI Specification section 8.1.9.1.

14.2.1.10 Mode Sense Command (1AH)

Implemented as described in the CDC SCSI Specification section 8.1.10 with the following WREN III HH specific parameters:

CDB Specification

The LUN must be zero, and the Flag and Link bits must be zero. See Table 19a.

TABLE 19a. MODE SENSE COMMAND
(Table 8-19 in CDC SCSI Spec)

BIT	7	6	5	4	3	2	1	0
0	0	0	0	1	1	0	1	0
1	LOGICAL UNIT NO.			0	0	0	0	0
2	PCF [1]		PAGE CODE (See Table 19b)					
3	0	0	0	0	0	0	0	0
4	ALLOCATION LENGTH (See Table 19b)							
5	0	0	0	0	0	0	FLAG	LINK
							0	0

[1] The content of Mode Parameter bytes is determined by the value of the PCF (Page Control Field) bits specified in CDB byte 2, bits 6 & 7 are as follows:

PCF Bit Mode Parameter Bytes Returned

<u>7</u>	<u>6</u>	
0	0	The WREN'S current values will be returned
0	1	The WREN'S changeable values will be returned
1	0	The WREN'S default values will be returned
1	1	The WREN'S saved values will be returned

14.2.1.10 (continued)

WREN III HH supports the following page codes. The allocation length should be the value in Table 19b or greater for the initiator to receive all of the possible available information for this page code.

TABLE 19b. MODE SENSE CDB SETUP

CDB PAGE CODE (CDB Byte 2, Bits 5-0)	LENGTH (DECIMAL)	MODE SENSE "DATA" RETURNED
00H	12	4 bytes of Mode Sense Header and 8 bytes of Block Descriptor Data
01H	20	4 bytes of Mode Sense Header 8 bytes of Block Descriptor Data 2 bytes of Error Recovery Header 6 bytes of Error Recovery Parameters [1]
02H	24	4 bytes of Mode Sense Header 8 bytes of Block Descriptor Data 2 bytes of Disconnect/Reconnect Control Header 10 bytes of Disconnect/Reconnect Control Parameters [1]
03H	36	4 bytes of Mode Sense Header 8 bytes of Block Descriptor Data 2 bytes of Format Control Header 22 bytes of Format Parameters [1]
04H	32	4 bytes of Mode Sense Header 8 bytes of Block Descriptor Data 2 bytes of Rigid Disk Drive Geometry Header 18 bytes of Rigid Disk Drive Geometry Parameters [1]
3FH	76	4 bytes of Mode Sense Header 8 bytes of Block Descriptor Data 64 bytes of Headers and parameter data for 01H, 02H 03H and 04H Page Codes. [1]

[1] See Note [1] for PCF description for Mode Sense CDB (Table 19a).

WREN III HH returned values of Mode Sense Header and Block Descriptor Data Definition is defined in Table 20a.

14.2.1.10 (continued)

TABLE 20a. MODE SENSE DATA
(Table 8-20 in CDC SCSI Spec)

BIT BYTE(S)	7	6	5	4	3	2	1	0
0	SENSE DATA LENGTH ("LENGTH" ENTRY OF TABLE 19b MINUS ONE)							
1	0	0	0	0	0	0	0	0
2	WP 0	RESERVED						
3	0	0	0	0	1	0	0	0
BLOCK DESCRIPTOR DATA								
0	DENSITY CODE							
1	0	0	0	0	0	0	0	0 [1]
2	0	0	0	0	0	0	0	0 [1]
3	0	0	0	0	0	0	0	0 [1]
4	RESERVED							
5	BLOCK LENGTH (MSB) [2]							
6	BLOCK LENGTH [2]							
7	BLOCK LENGTH (LSB) [2]							
PARAMETER INFORMATION								
0-n	MODE SENSE PAGE HEADERS AND THEIR PARAMETERS (See Table 20b)							

[1] All Zeros to signify one block length for the entire LUN.

[2] Block length (sector size) from 256 to 2048 as defined after a Format Function. Default is 512 if no Mode Select command is received before the Format command.

14.2.1.10 (continued)

TABLE 20b. MODE SENSE PAGE DESCRIPTOR HEADER
(Table 8-21 in CDC SCSI Spec)

BIT	7	6	5	4	3	2	1	0
BYTE(S)								
0	PS	0	PAGE CODE					[1]
1	PAGE LENGTH						[1]	
2-n	MODE PARAMETERS						[1]	

[1]	<u>PAGE CODE</u>	<u>PAGE DESCRIPTION</u>	<u>REFERENCE TABLE</u>
	01	Error Recovery	21
	02	Disconnect/Reconnect Control	22
	03	Format Parameters	23a
	04	Rigid Disk Drive Geometry	23b

WREN III HH Error Recovery Page implementation is defined in Table 21. This Table summarizes: the function; the default value; and changeability status for each Byte/bit.

TABLE 21. ERROR RECOVERY PAGE
(Table 8-22 in CDC SCSI Spec)

PAGE DESCRIPTOR HEADER									
BIT	7	6	5	4	3	2	1	0	
BYTE(S)									
0	PS 1 [1]	0	0	0	0	0	0	1	PAGE CODE (1 Decimal)
1	0	0	0	0	0	1	1	0	PAGE LENGTH (BYTES) - 6 Decimal
ERROR RECOVERY PARAMETERS									
2	AWRE	ARRE	TB	RC	EEC	PER	DTE	DCR	
DEFAULT	0	0	0	0	0	0	0	0	
CHANGE- ABLE [2]	1	1	1	1	1	1	1	1	
3	RETRY COUNT								
DEFAULT	0	0	0	1	1	0	1	1	27 Decimal
CHANGE- ABLE [2]	1	1	1	1	1	1	1	1	[3]
4	CORRECTION SPAN (bits)- 8 Decimal								
DEFAULT	0	0	0	0	1	0	0	0	[4]
CHANGE- ABLE [2]	0	0	0	0	0	0	0	0	
5	HEAD OFFSET COUNT								
DEFAULT	0	0	0	0	0	0	0	0	
CHANGE- ABLE [2]	0	0	0	0	0	0	0	0	
6	DATA STROBE OFFSET COUNT								
DEFAULT	0	0	0	0	0	0	0	0	
CHANGE- ABLE [2]	0	0	0	0	0	0	0	0	
7	RECOVERY TIME LIMIT								
DEFAULT	1	1	1	1	1	1	1	1	[5]
CHANGE- ABLE [2]	0	0	0	0	0	0	0	0	

See following page for notes.

TABLE 21. ERROR RECOVERY PAGE (continued)
(Table 8-22 in CDC SCSI Spec)

- [1] The returned PS (Parameter Savable) bit of 1 indicates that page 01H parameter data is savable.
- [2] A value of zero means this bit function is not directly changeable by an initiator, a value of 1 means the bit function is directly changeable by an initiator. (See Mode Select Command)
- [3] The Retry Count is changeable between 0 and 27 inclusive. A Retry Count of zero will inhibit retries from being performed. If the EEC bit is set, the number of retries specified by the Retry Count, up to a maximum of nine retries, will be performed before ECC is applied.
- [4] Errors longer than this span are reported as unrecoverable.
- [5] A Hex FF indicates the Recovery Time Limit is unlimited.

14.2.1.10 (continued)

The WREN III HH Disconnect/Reconnect Page implementation is defined in Table 22. This Table summarizes the Function and defines the default value. An Initiator may not directly change the default values. Consequently the changeable status is always zero for all bytes/bits in this page.

TABLE 22. DISCONNECT/RECONNECT CONTROL PAGE
(Table 8-23 in CDC SCSI Spec)

PAGE DESCRIPTOR HEADER

BIT BYTE(S)	7	6	5	4	3	2	1	0	
0	PS 1 [1]	0	PAGE CODE (3 Decimal)						0
1	PAGE LENGTH (10 Decimal)								
	0	0	0	0	1	0	1	0	

DISCONNECT/RECONNECT CONTROL PARAMETERS

2 DEFAULT	[2]0 [3]X	0 X	0 X	0 X	0 X	0 X	0 X	0 X	0 X
3 DEFAULT	BUFFER FULL RATIO								
	SAME VALUES AS BUFFER FULL RATIO								
4 DEFAULT	0	0	0	0	0	0	0	0	0
5 DEFAULT	0	0	0	0	1	0	1	0	[4]
6,7	BUS INACTIVITY LIMIT (MSB)								
	0	0	0	0	0	0	0	0	0
8,9	BUS INACTIVITY LIMIT (LSB) (10 Decimal)								
	0	0	0	0	0	0	0	0	0
10,11	DISCONNECT TIME LIMIT								
	0	0	0	0	0	0	0	0	0
	CONNECT TIME LIMIT								
	0	0	0	0	0	0	0	0	0
	RESERVED								
	0	0	0	0	0	0	0	0	0

[1] The PS (Parameter Savable) bit of 1 indicates that the page 02H parameter data is savable.

[2] 00 Hex per sector sizes of 256 to 511 Bytes/sector drive will attempt to reconnect 6 sector times before the first sector to be read or written.

[3] A ratio to signify one sector. Value is equal to the sector size times 256 divided by 8192 e.g. equal to 10 hex for 512 Byte sectors, 20 Hex for 1024 Byte sectors, etc. Default is 10 Hex for 512 Byte sectors unless sector size is changed by the Initiator. Drive will attempt reconnection as the first sector is being read (or written) and will attempt to send the ID messages as the second sector is being read (or written) if the Host is reconnected within 1 sector time.

[4] 1 millisecond

14.2.1.10 (continued)

The WREN III HH Format Parameters Page implementation is defined in Table 23a. This Table summarizes the Function and defines the default value. An Initiator may not directly change the default values, thus the changeable status is always zeros for all bytes/bits in this page.

TABLE 23a. FORMAT PARAMETER PAGE
(Table 8-24 in CDC SCSI Spec)

PAGE DESCRIPTOR HEADER										
BIT	7	6	5	4	3	2	1	0		
BYTE(S)										
0	PS 1		PAGE CODE (3 Decimal)							
	[1]	0	0	0	0	0	1	1		
1	PAGE LENGTH (22 Decimal)									
	0	0	0	1	1	0	1	0		
FORMAT PARAMETERS										
2	TRACKS PER ZONE (MSB)									
	0	0	0	0	0	0	0	0		
3	TRACKS PER ZONE (LSB)									
	0	0	0	0	0	0	0	1		
4	ALTERNATE SECTORS PER ZONE (MSB)									
	0	0	0	0	0	0	0	0		
5	ALTERNATE SECTORS PER ZONE (LSB)									
	0	0	0	0	0	0	0	1		
6	ALTERNATE TRACKS PER ZONE (MSB)									
	0	0	0	0	0	0	0	0		
7	ALTERNATE TRACKS PER ZONE (LSB)									
	0	0	0	0	0	0	0	0		
8	ALTERNATE TRACKS PER VOLUME (MSB)									
	0	0	0	0	0	0	0	0		
9	ALTERNATE TRACKS PER VOLUME (LSB)									
	0	0	0	0	0	0	0	0		
10	PHYSICAL SECTORS PER TRACK (MSB)									
	0	0	0	0	0	0	0	0		
11	PHYSICAL SECTORS PER TRACK (LSB)									
	X	X	X	X	X	X	X	X	[2]	
12,13	DATA BYTES PER SECTOR									
	X	X	X	X	X	X	X	X	[3]	
14,15	INTERLEAVE									
	X	X	X	X	X	X	X	X	[4]	
16,17	TRACK SKEW FACTOR									
	X	X	X	X	X	X	X	X	[5]	
18,19	CYLINDER SKEW									
	X	X	X	X	X	X	X	X	[6]	
20	S	H	R	S	I	R	R	R		
	0	1	0	0	0	0	0	0		
21,22,23	RESERVED									
	0	0	0	0	0	0	0	0		

See following page for notes.

14.2.1.10 (continued)

TABLE 23a. FORMAT PARAMETER PAGE (continued)
(Table 8-24 in CDC SCSI Spec)

- [1] The PS (Parameter Savable) bit of 1 indicates that page 02H parameter data is savable. This data will be saved only after a Format Command is executed.
- [2] A value between 5 and 65 depending on selected sector size. The number of user sectors per track is one less than this reported value. Default is 36 for 512 byte sector size.
- [3] A value between 256 and 2048 signifying the user data bytes per sector. Default is 512.
- [4] Formatted interleave value. Default is 0001H.
- [5] Equals 0 for sector sizes between 512 and 2048 bytes. Equals 1 for sector sizes between 256 and 511 bytes. Drive will not lose a revolution on a Head change.
- [6] A value equal to one half the number of sectors on a track. The drive will lose less than one half revolution on a cylinder change.

14.2.1.10 (continued)

The WREN III HH Rigid Disk Drive Geometry Parameters Page implementation is defined in Table 23b. This table summarizes the Function and defines the default value. An Initiator may not directly change the default values, thus the changeable status is always zero for all bytes/bits in this page.

TABLE 23b. RIGID DISK DRIVE GEOMETRY PARAMETERS
(Table 8-25 in CDC SCSI Spec)

PAGE DESCRIPTOR HEADER									
BIT BYTE(S)	7	6	5	4	3	2	1	0	
0	[1]PS 1	0	0	0	0	1	0	0	PAGE CODE (4 Decimal)
1	0	0	0	1	0	0	1	0	PAGE LENGTH (18 Decimal)
RIGID DISK DRIVE GEOMETRY PARAMETERS									
2	0	0	0	0	0	0	0	0	NUMBER OF CYLINDERS (MSB) [2]
3	0	0	0	0	0	0	1	1	NUMBER OF CYLINDERS [2]
4	1	1	1	1	1	1	1	0	NUMBER OF CYLINDERS (LSB) [2]
5									NUMBER OF HEADS [3]
6,7,8	0	0	0	0	0	0	0	0	STARTING CYLINDER - WRITE PRECOMP [4]
9,10,11	0	0	0	0	0	0	0	0	STARTING CYLINDER-REDUCED WRITE CURRENT [4]
12,13	0	0	0	0	0	0	0	0	DRIVE STEP RATE [4]
14,15,16	0	0	0	0	0	0	0	0	LOADING ZONE CYLINDER [4]
17,18,19	0	0	0	0	0	0	0	0	RESERVED [4]

[1] The PS bit of 1 indicates that page 04 parameter data is savable and will be saved only when a Format function is performed.

[2] 1022 user accessible cylinders.

[3] Either 3, 4, or 5 depending on drive model number.

[4] Not applicable.

14.2.1.11 Start/Stop Unit Command (1BH)

Implemented per the CDC SCSI specification section 8.1.11 with the following WREN III HH specific parameters. See Table 14.2.1.11.

TABLE 14.2.1.11. START UNIT COMMAND
(Table 8-26 in CDC SCSI Spec)

BIT BYTE(S)	7	6	5	4	3	2	1	0	
0	0	0	0	1	1	0	1	1	
1	LOGICAL UNIT NO.							IMMED	
	0	0	0	0	0	0	0		
2	0	0	0	0	0	0	0	0	
3	0	0	0	0	0	0	0	0	
4	0	0	0	0	0	0	0	START 1	
5	0	0	0	0	0	0	FLAG 0	LINK 0	

The Start Unit command requests the target enable the logical unit for further operations.

The start bit must be a one. This requests the logical unit be made ready for use. If the start bit is zero the command will be rejected as an illegal request.

This command is applicable only if the Motor Start Option Jumper is installed. See Figure 9, 10 and 13. If the jumper is not installed the WREN III HH will not respond to any communications on the interface until power has been applied, the drive is up to speed, and the heads have been loaded and positioned over Track Zero.

14.2.1.12 Prevent/Allow Medium Removal Command (1EH)

Not Implemented by WREN III HH. If received WREN III HH will terminate with "Check Condition" status and set an "Illegal Request" Sense Key.

14.2.2 GROUP 1 COMMAND FOR DIRECT ACCESS DEVICES

The Group 1 Commands Implemented by the WREN III HH are listed in Table 24.

TABLE 24. GROUP 1 COMMANDS FOR DIRECT ACCESS DEVICES
(Table 8-28 in CDC SCSI Spec)

OPERATION CODE (HEX)	COMMAND NAME	SECTION
25	Read Capacity	14.2.2.1
28	Read Extended	14.2.2.2
2A	Write Extended	14.2.2.3
2B	Seek Extended	14.2.2.4
2E	Write and Verify	14.2.2.5
2F	Verify	14.2.2.6
37	Read Defect Data	14.2.2.9
3B	Write Data Buffer	14.1.2.3
3C	Read Data Buffer	14.1.2.4
3E	Read Long	14.2.2.10
3F	Write Long	14.2.2.11

14.2.2.1 Read Capacity Command (25H)

Implemented as described in the CDC SCSI Specification section 8.2.1 with the following WREN III HH specific parameters. See Table 25a.

TABLE 25a. READ CAPACITY COMMAND
(Table 8-29 in CDC SCSI Spec)

BIT BYTE(S)	7	6	5	4	3	2	1	0
0	0	0	1	0	0	1	0	1
1	LOGICAL UNIT NO.							
	0	0	0	0	0	0	0	0
2	LOGICAL BLOCK ADDRESS (MSB)							
3	LOGICAL BLOCK ADDRESS							
4	LOGICAL BLOCK ADDRESS							
5	LOGICAL BLOCK ADDRESS (LSB)							
6	0	0	0	0	0	0	0	0
7	0	0	0	0	0	0	0	0
8	0	0	0	0	0	0	0	PMI
9	0	0	0	0	0	0	FLAG	LINK
							0	0

In the CDB the LUN must be zero and the Flag and Link bits must be zero. The WREN III HH supports this command for a PMI bit of zero or one. If the PMI bit is a one, the WREN III HH defines a substantial delay in data transfer as 1.0 millisecond. This may result in reporting one of the following boundaries: a) a Cylinder boundary or b) a media flaw location.

14.2.2.1 (continued)

The returned 8 bytes of Capacity Data is per table 25b.

TABLE 25b. CAPACITY DATA
(Table 8-30 in CDC SCSI Spec)

<u>BYTE</u>	<u>DESCRIPTION</u>	
0	Logical Block Address (MSB)	[1]
1	Logical Block Address	[1]
2	Logical Block Address	[1]
3	Logical Block Address (LSB)	[1]
4	Block Length (MSB)	[2]
5	Block Length	[2]
6	Block Length	[2]
7	Block Length (LSB)	[2]

[1] Maximum Logical Address never changes for a given block size regardless of flaw allocation. Values are given at [1] in table below.

[2] See table below at [2].

READ CAPACITY DATA (If PMI Bit = 0)

LOGICAL BLOCK ADDRESS	BLOCK LENGTH [2]
<u>Decimal</u> [1]	<u>Hex</u> [1]

178,849	2BAA1H	512	5 R/W heads
327,039	4FD7FH	256	
91,979	1674BH	1024	

XXXXXX	YYYYYH	Any other sector size between 256 and 2048, with 3,4 or 5 R/W heads.	
--------	--------	--	--

14.2.2.2 Read Extended Command (28H)

Implemented as described in the CDC SCSI Specification section 8.2.2 with the following WREN III HH specific parameters. See Format in Table 25c.

TABLE 25c. READ EXTENDED COMMAND
(Table 8-31 in CDC SCSI Spec)

BIT BYTE(S)	7	6	5	4	3	2	1	0
0	0	0	1	0	1	0	0	0
1	LOGICAL UNIT NO.							
	0	0	0	0	0	0	0	0
2	LOGICAL BLOCK ADDRESS (MSB)							
3	LOGICAL BLOCK ADDRESS							
4	LOGICAL BLOCK ADDRESS							
5	LOGICAL BLOCK ADDRESS (LSB)							
6	0	0	0	0	0	0	0	0
7	TRANSFER LENGTH (MSB)							
8	TRANSFER LENGTH (LSB)							
9	0	0	0	0	0	0	FLAG	LINK
							0	0

In the CDB the LUN must be zero and the Flag and Link bits must be zero. (Per the CDC SCSI Specification section 8.2.2, Relative Addressing is not implemented).

This Command operates the same as the Read Command (section 14.2.1.4) except that in the CDB for this Command a four byte Logical Block Address and a two byte Transfer Length may be specified. A Transfer Length value of zero means no data transferred.

14.2.2.3 Write Extended Command (2AH)

Implemented as described in the CDC SCSI Specification section 8.2.3 with the following WREN III HH specific parameters. See Format in Table 25d.

TABLE 25d. WRITE EXTENDED COMMAND
(Table 8-32 in CDC SCSI Spec)

BIT BYTE(S)	7	6	5	4	3	2	1	0
0	0	0	1	0	1	0	1	0
1	LOGICAL UNIT NO.							
	0	0	0	0	0	0	0	0
2	LOGICAL BLOCK ADDRESS (MSB)							
3	LOGICAL BLOCK ADDRESS							
4	LOGICAL BLOCK ADDRESS							
5	LOGICAL BLOCK ADDRESS (LSB)							
6	0	0	0	0	0	0	0	0
7	TRANSFER LENGTH (MSB)							
8	TRANSFER LENGTH (LSB)							
9	0	0	0	0	0	0	FLAG	LINK
							0	0

In the CDB, the LUN must be zero and the Flag and Link bits must be zero. (Per the CDC SCSI specification, Relative Addressing is not supported.)

This Command operates the same as the Write command (section 14.2.1.5) except that in the CDB for this command a four byte Logical Block Address and a two byte Transfer Length may be specified. A Transfer Length of zero means no data is to be transferred.

14.2.2.4 Seek Extended Command (2BH)

Implemented as described in the CDC SCSI specification section 8.2.4 with the following WREN III HH specific parameters. See Format in Table 25e.

TABLE 25e. SEEK EXTENDED COMMAND
(Table 8-33 in CDC SCSI Spec)

BIT BYTE(S)	7	6	5	4	3	2	1	0
0	0	0	1	0	1	0	1	1
1	LOGICAL UNIT NO.							
	0	0	0	0	0	0	0	0
2	LOGICAL BLOCK ADDRESS (MSB)							
3	LOGICAL BLOCK ADDRESS							
4	LOGICAL BLOCK ADDRESS							
5	LOGICAL BLOCK ADDRESS (LSB)							
6	0	0	0	0	0	0	0	0
7	0	0	0		0	0	0	0
8	0	0	0	0	0	0	0	0
9	0	0	0	0	0	0	FLAG	LINK
							0	0

In the CDB, the LUN must be zero and the Flag and Link bits must be zero. (per the CDC SCSI specification, Relative Addressing is not supported). This command operates the same as the Seek command (section 14.2.1.6) except that a four byte Logical Block Address is specified.

14.2.2.5 Write and Verify Command (2EH)

Implemented per the CDC SCSI Specification section 8.2.5 with the following WREN III specific parameters. See Format in table 25f.

TABLE 25f. WRITE AND VERIFY COMMAND
(Table 8-34 in CDC SCSI Spec)

BIT BYTE(S)	7	6	5	4	3	2	1	0	
0	0	0	1	0	1	1	1	0	
1	LOGICAL UNIT NO.						BYT CHK	0	0
2	LOGICAL BLOCK ADDRESS (MSB)								
3	LOGICAL BLOCK ADDRESS								
4	LOGICAL BLOCK ADDRESS								
5	LOGICAL BLOCK ADDRESS (LSB)								
6	0	0	0	0	0	0	0	0	
7	TRANSFER LENGTH (MSB)								
8	TRANSFER LENGTH (LSB)								
9	0	0	0	0	0	0	FLAG 0	LINK 0	

In the CDB the LUN must be zero and the Flag and Link bits must be zero. (Per the CDC SCSI specification, Relative Addressing is not implemented).

The Byte Check (BYT CHK) bit must be zero. This requests that the verification to be simply an ECC verification. If the Byte Check bit is one, the command will be rejected as an illegal request.

All data will be transferred by the host and written before the verify operation takes place.

14.2.2.6 Verify Command (2FH)

Implemented per the CDC SCSI Specification section 8.2.6 with the following WREN III specific parameters. See Format in table 25g.

TABLE 25g. VERIFY COMMAND
(Table 8-35 in CDC SCSI Spec)

BIT BYTE(S)	7	6	5	4	3	2	1	0
0	0	0	1	0	1	1	1	1
1	LOGICAL UNIT NO.						BYT CHK	0
	0	0	0	0	0	0	0	0
2	LOGICAL BLOCK ADDRESS (MSB)							
3	LOGICAL BLOCK ADDRESS							
4	LOGICAL BLOCK ADDRESS							
5	LOGICAL BLOCK ADDRESS (LSB)							
6	0	0	0	0	0	0	0	0
7	VERIFICATION LENGTH (MSB)							
8	VERIFICATION LENGTH (LSB)							
9	0	0	0	0	0	0	FLAG	LINK
							0	0

In the CDB, the LUN must be zero and the Flag and Link bits must be zero. (Per the CDC SCSI specification, Relative Addressing is not supported).

The Byte Check (BYT CHK) bit must be zero. This requests that the verification to be simply an ECC verification. No data will be transferred with this command. If the Byte Check bit is one, the command will be rejected as an illegal request.

14.2.2.7 Search Data Commands (30H, 31H, or 32H)

Not Implemented. If received, will be treated as an illegal request.

14.2.2.8 Set Limits Command (33H)

Not Implemented. If received, will be treated as an illegal request.

14.2.2.9 Read Defect Data Command (37H)

Implemented Per the CDC SCSI Specification section 8.2.9 with the following WREN III HH specific parameters. See format in Table 25h.

TABLE 25h. READ DEFECT DATA COMMAND
(Table 8-36 in CDC SCSI Spec)

BIT BYTE(S)	7	6	5	4	3	2	1	0
0	0	0	1	1	0	1	1	1
1	LOGICAL UNIT NO.			0	0	0	0	0
2	0	0	0	P	G	DEFECT LIST FORMAT		
				[1]		[2]		
3	0	0	0	0	0	0	0	0
4	0	0	0	0	0	0	0	0
5	0	0	0	0	0	0	0	0
6	0	0	0	0	0	0	0	0
7	ALLOCATION LENGTH (MSB)							
8	ALLOCATION LENGTH (LSB)							
9	0	0	0	0	0	0	FLAG	LINK
							0	0

14.2.2.9 (continued)

In the CDB the LUN must be zero and the Flag and Link bits must be zero.

- [1] The WREN III HH interprets the P and G bits (bits 4 and 3 of byte 2 of the CDB) as follows:

<u>BIT P</u>	<u>BIT G</u>	
0	0*	Return Defect List header only
0	1	Return the grown "G" list only.
1	0	Return the manufacturers original ETF list ("P" List) only.
1	1	Return all lists of flaws.

- * If the P, G bits were 0,0 the Defect List length will reflect the length of the 1,1 list and no Defect descriptor Bytes will be sent to the initiator.

- [2] The Defect List Format bits will be interpreted as follows:

BIT
2 1 0

1 0 0 The drive will return a defect list to the initiator in a Bytes From Index format.

1 0 1 The drive will return a defect list to the initiator in a Physical Sector format. This is the default format.

Any other combination The WREN III HH will respond in accordance with the CDC SCSI Specification for nonsupported formats. (See CDC SCSI Spec. Section 8.2.9.).

14.2.2.9 (continued)

This command is intended to be used only with the Format Unit command (CDC SCSI specification section 8.1.2). The Initiator should not interpret or act upon this List except to resend this list as Defect Data in a Format Unit command.

The Defect Data returned is as shown in Table 26a:

TABLE 26a. DEFECT LIST HEADER DESCRIPTION
(Table 8-5 in CDC SCSI Spec)

BIT BYTE(S)	7	6	5	4	3	2	1	0	
0	RESERVED								
	0	0	0	0	0	0	0	0	
1	RESERVED			P	G	DEFECT LIST FORMAT			
	0	0	0	[1]		[2]			
2	DEFECT LIST LENGTH (MSB)							[3]	[4]
3	DEFECT LIST LENGTH (LSB)							[3]	[4]
4-n	DEFECT DESCRIPTOR BYTES							[3]	[5]

- [1] Either 00, 01, 10, or 11 as previously defined in this section.
- [2] Defines format of list returned by drive. See Note 2 for Table 25h.
- [3] If the P, G bits were 0,0 the Defect List length will reflect the length of the 1,1 list and no Defect Descriptor Bytes will be sent to the initiator.
- [4] Value is 8 times the number of defective sectors.
- [5] Drive returns defect information as defined in Tables 16b and 16c.

14.2.2.10 Read Long Command (3EH)

TABLE 26b. READ LONG COMMAND

BIT	7	6	5	4	3	2	1	0
BYTE(S)								
0	0	0	1	1	1	1	1	0
1	LOGICAL UNIT NO.							
	0	0	0	0	0	0	0	0
2	LOGICAL BLOCK ADDRESS (MSB)							
3	LOGICAL BLOCK ADDRESS							
4	LOGICAL BLOCK ADDRESS							
5	LOGICAL BLOCK ADDRESS (LSB)							
6	0	0	0	0	0	0	0	0
7	BYTE TRANSFER LENGTH (MSB)							
8	BYTE TRANSFER LENGTH (LSB)							
9	0	0	0	0	0	0	FLAG	LINK
							0	0

14.2.2.10 continued

The Read Long command requests that the target transfer data to the initiator. The data passed during the Read Long command shall include the data bytes followed by the four ECC bytes of the single logical block addressed by the command. No correction to the data will be made by the target.

The logical block address specifies the logical block at which the read operation shall occur. The most recent data written in the addressed logical block shall be returned.

The byte transfer length specifies the number of bytes of data that shall be transferred. A transfer length of zero indicates that no bytes shall be transferred. This condition shall not be considered as an error. The byte transfer length requested must be equal to the current block size plus four for a data transfer to occur. If the incorrect amount of bytes are stated in the command block, this command will be terminated with a Check Condition status. The correct amount of bytes can be determined from the information that is returned in the extended sense data bytes after issuing the Request Sense command. The Request Sense command shall result in the Illegal Field In CDB Condition with the Illegal Request Sense Key. The extended sense ILI bit shall be set. The extended sense information bytes contain the difference (residue) of the requested length minus the actual length in bytes. (Negative values are indicated by two's complement notation.)

In the CDB, the LUN must be zero and the Flag and Link bits must be zero. (Per the CDC SCSI specification, Relative Addressing is not supported).

14.2.2.11 Write Long Command (3FH)

TABLE 26c. WRITE LONG COMMAND

BIT BYTE(S)	7	6	5	4	3	2	1	0
0	0	0	1	1	1	1	1	1
1	LOGICAL UNIT NO.							
	0	0	0	0	0	0	0	0
2	LOGICAL BLOCK ADDRESS (MSB)							
3	LOGICAL BLOCK ADDRESS							
4	LOGICAL BLOCK ADDRESS							
5	LOGICAL BLOCK ADDRESS (LSB)							
6	0	0	0	0	0	0	0	0
7	BYTE TRANSFER LENGTH (MSB)							
8	BYTE TRANSFER LENGTH (LSB)							
9	0	0	0	0	0	0	FLAG	LINK
							0	0

14.2.2.11 continued

The Write Long command requests that the target write to the medium the data transferred by the initiator. The data passed during the Write Long command shall include the data bytes and the four ECC bytes to be written to the single logical block addressed in the command. The Read Long command is usually issued before issuing a Write Long command. The Write Long bytes passed must be in the same order and must be the same amount of bytes as the Read Long command.

The logical block address specifies the logical block at which the write operation shall occur.

The byte transfer length specifies the number of bytes of data that shall be transferred. A transfer length of zero indicates that no bytes shall be transferred. This condition shall not be considered as an error. The byte transfer length requested must be equal to the current block size plus four for a data transfer to occur. If the incorrect amount of bytes are stated in the command block, this command will be terminated with a Check Condition status. The correct amount of bytes can be determined from the information that is returned in the extended sense data bytes after issuing the Request Sense command. The Request Sense command shall result in the Illegal Field In CDB Condition with the Illegal Request Sense Key. The extended sense ILI bit shall be set. The extended sense information bytes contain the difference (residue) of the requested length minus the actual length in bytes. (Negative values are indicated by two's complement notation.)

In the CDB the LUN must be zero and the Flag and Link bits must be zero. (Per the CDC SCSI specification, Relative Addressing is not implemented).

15.0 STATUS

Implemented as described in the CDC SCSI Specification section 14.0 with the following WREN III HH specific parameters.

The drive will return one of the completion status byte codes listed in Table 27. (Refer to Table 14-2 of the CDC SCSI specification).

TABLE 27. COMMAND COMPLETION STATUS

<-----BITS----->								STATUS REPRESENTED
7	6	5	4	3	2	1	0	
0	0	0	0	0	0	0	0	Good
0	0	0	0	0	0	1	0	Check Condition
0	0	0	0	1	0	0	0	Busy
0	0	0	1	1	0	0	0	Reservation Conflict

16.0 ERROR RECOVERY PHILOSOPHY

The error recovery procedures for the WREN III HH vary in accordance with parameter values and the states of "flags" stored in error recovery parameter storage locations in WREN III HH control memory. The WREN III HH control firmware error recovery routines reference these parameters for decision making when an error recovery procedure is performed. Some of these error recovery parameters are changeable by commands from the initiator and some are not. Those changeable are flagged as such and this information is given to the initiator when requested by a Mode Sense command. The error recovery parameters that are allowed to be changed may be changed by a Mode Select command from the Initiator. Table 28 lists the error recovery parameters. More details on how these functions operate are given in Sections 8.1.7 and 8.1.10 of the CDC SCSI Specification.

16.0 (continued)

TABLE 28. ERROR RECOVERY PARAMETERS

CHANGEABILITY
INDICATOR**

<u>PARAMETER NAME</u>		<u>VALUE</u>	<u>DESCRIPTION OF PARAMETER</u>
AWRE	1	1 or 0*	Automatic Write Reallocation Enable
ARRE	1	1 or 0*	Automatic Read Reallocation Enable
TB	1	1 or 0*	Transfer (failed data) Block
RC	1	1 or 0*	Read Continuous (no recovery actions)
EEC	1	1 or 0*	Enable ECC correction to occur early
PER	1	1 or 0*	Post Error (report to Initiator)
DTE	1	1 or 0*	Disable data Transfer on Recovered Error
DCR	1	1 or 0*	Disable ECC application
Retry cnt	1	0 - 27	Maximum times for read retry algorithm (Default is 27)
Correction Span	0	8	Largest error span for ECC use (bits)

*Default value is 0 which means disable.

**0 means not changeable.

In general, when a read error occurs, the WREN III HH will attempt to recover using retries, application of ECC and/or early application of ECC (if these are enabled). If the error still exists, the WREN III HH will report Check Condition in the status returned to the initiator. The initiator will likely command Request Sense and the WREN III HH will reply with a Data In phase with 18 bytes of Extended Sense Data that will contain information about the error. Sense Key codes used and their meanings are shown in Table 8. Error codes used and the errors they report are listed in Table 9. If the error is recovered, it will be reported only if the PER bit is set (Table 28). Error recovery procedures for several of the error conditions are defined in Sections 16.1 through 16.5.

16.1 SEEK ERRORS (09 or 15 HEX ERROR CODE)

If a seek error occurs, up to three retries will be attempted by positioning the heads to track zero and reissuing the seek. If all retries fail, error code 09 or 15 will be reported in the Extended Sense Data.

16.2 DATA FIELD WRITE FAULT (03 HEX ERROR CODE)

If a write fault is detected while writing the data field the operation will be immediately suspended. If the internal write fault can be cleared, the drive will automatically perform a rewrite of the sector (up to 3 attempts will be made to clear the write fault and rewrite the sector).

If the write fault condition cannot be cleared the "Write Fault" error (03 Hex) will be reported in extended Sense Data.

16.3 SYNC BYTE ERROR (12 Hex Error Code)

If the sync byte cannot be recovered during a read, up to 27 retries will be attempted using the offset and data strobe combinations shown in Figure 14.

16.4 DATA FIELD ECC ERROR (11 Hex or 18 Hex Error Code)

If EEC bit is one (Table 21), ECC correction is applied as soon as possible. If EEC bit is zero data field ECC error correction is not applied until all retry attempts are exhausted and if specified by DCR bit and retry count (Table 21). If the ECC error persists and is within the correction length being used (8 bits) the data is corrected and sent to the Initiator if that capability is enabled by DTE bit (Table 21). Data correction by ECC will not occur unless two ECC syndrome matches occur. For unrecoverable ECC errors an error code of 11 hex is reported.

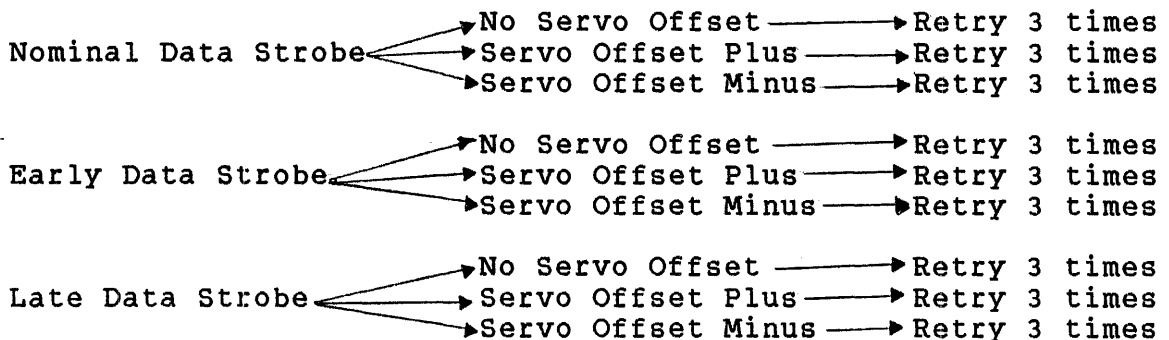

FIGURE 14. POSSIBLE DATA STROBE AND SERVO OFFSET COMBINATIONS USED BY THE SCSI WREN DURING READ RETRIES

16.5 ALTERNATE SECTOR PROCESSING

Any media defect detected during formatting or listed internally in the factory recorded defect table will already have been assigned an alternate sector in an area not directly accessible by the initiator. If conditions are appropriate, the initiator may want to call for a complete reformatting of the WREN III HH. The options available when that is done are discussed in Section 14.2.1.2.

Read errors that occur after formatting and require ECC correction to recover or are uncorrectable will be reported to the initiator with an Extended Sense reply to the initiator's Request Sense command. The initiator should request that the bad sector(s) be reassigned using a Reassign Blocks command. The WREN III HH lists the sector(s) in the defects list and reassigns the bad sectors to an available spare sector(s). The alternate sector(s) used are in a reserved portion of the WREN III HH and are invisible to the initiator.

16.6 AUTOMATIC READ REALLOCATION

This function enables the WREN III to automatically reallocate sectors which contain a recovered data error found during the execution of a Read command. A sector will be considered for reallocation provided there was at least one retry performed to recover the data within the constraints of the error recovery parameters. If this occurs, the recovered data is first rewritten to the original sector and verified. Sectors that fail this verify are then reallocated.

After the sector is reallocated, the sector's data is written and verified at the new location. Any unrecoverable error occurring during this process will be reported immediately. The reporting of the original recovered error is controlled by the error recovery byte. Normally, the reallocation operation is transparent to the host.

16.7 AUTOMATIC WRITE REALLOCATION

This function allows the WREN III to automatically reallocate bad sectors found during execution of a Write command. Sectors that are unable to be written because of media errors will be reallocated after the retries are exhausted. After the sector is reallocated, the data for this sector is written at the new location. Any unrecoverable error that occurs during the reallocation procedure will be reported. Under normal conditions, this operation is transparent to the host.

17.0 OPTIONS

All options are either incorporated or packaged at the manufacturing facility. Ground isolation capability is provided on every main PWA shipped, and the user may exercise his option to isolate grounds at his convenience. See paragraph 17.2.

17.1 FRONT PANEL

The front panel is available in black plastic. Each panel has a single red rectangular lens which, when glowing, indicates the drive is selected.

17.2 AC/DC GROUND SEPARATION

The 94211 WREN III HH is provided with the AC ground (chassis) tied to DC logic ground. An option is provided for the user to isolate the AC and DC grounds. This option may be beneficial in reducing ground induced noise in some system applications. (See Figures 4 and paragraph 7.2.3.)

17.3 SINGLE UNIT SHIPPING PACK

The 94211 WREN III HH is normally shipped in bulk packaging to provide maximum protection against transit damage. Units shipped individually require additional protection as provided by the single unit shipping pack. Users planning single unit distribution should specify this option.

17.4 DRIVE TERMINATION

This option may be incorporated during manufacture at the request of the customer. Termination consists of three 220/330 ohm resistor modules which are installed on the main PWA via sockets. The user may install or remove these. See Figure 10.

18.0 ACCESSORIES

All accessories are designed for implementation by the customer.

18.1 FRONT PANEL KIT

Same as 17.1 but includes all mounting hardware to support field installation.

18.2 OEM MANUAL

This manual provides basic information on the care and handling of Winchester Disk Peripherals in general. Specific instructions for installing the WREN III HH are included to assist individuals not familiar with the product. It also includes basic information describing repair procedures for items external to the Head/Disk Assembly (HDA).

STAPLE

STAPLE

FOLD

FOLD



NO POSTAGE
NECESSARY
IF MAILED
IN THE
UNITED STATES

BUSINESS REPLY MAIL
FIRST CLASS PERMIT NO 1332 OKLAHOMA CITY OKLA

POSTAGE WILL BE PAID BY ADDRESSEE

CONTROL DATA CORP.

P.O. BOX 12313

OKLAHOMA CITY, OKLAHOMA 73157

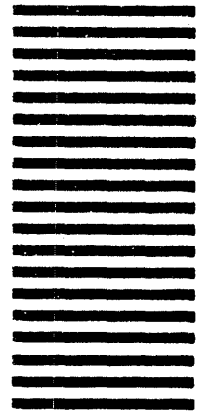

CUT ALONG LINE

Attention ***Rigid Disk Applications Engineering, OKM 272***

FOLD

FOLD