

**CONTROL DATA®
SPECIAL OPTION 60026
MAGNETIC TAPE CONTROLLER**

**DESCRIPTION
PROGRAMMING AND
OPERATION
CIRCUIT DIAGRAMS
PARTS LIST**

REVISION RECORD

REVISION	DESCRIPTION
A (12-7-66)	This manual released at Product Designation Special Option 60026-A01. This document reassigned to Publications Division (previously System Science Division).
B (8-2-67)	Field Change Order 15215, new Product Designation Special Option 60026-A02 (MDR 8). Pages revised; 4-7 and 4-31.
C (6-6-68)	Field Change Order 19479, New Product Designation Special Option 60026-A03. Pages 4-4, 4-20, 4-21, 4-25 revised.
D (10-31-69)	Manual revised; includes Field Change Order 21897, Equipment level Special Option 60026-A01 through A04. Pages 4-6, 4-19, 4-32, and 4-33 revised.
Publication No. 38705100	

Address comments concerning this manual to:
 Control Data Corporation
 Technical Publications Department
 4201 North Lexington Avenue
 Arden Hills, Minnesota 55112
 or use Comment Sheet in the back of this manual.

PREFACE

The following documents, in addition to this manual, form the complete set of manuals for Special Option 60026.

Publication Number	Description
17772400	Special Option 60026 Magnetic Tape Controller engineering documentation (wire list, equation file, and chassis map)

CONTENTS

<u>Section</u>	<u>Title</u>	<u>Page</u>
1	Introduction	1-1
2	Description	2-1
	Physical Description	2-1
	Equipment Data	2-1
	Functional Description	2-1
	Magnetic Tape	2-2
	Tape Format	2-3
	Data Transmissions and Parity	2-5
	Data Channel ↔ Tape Synchronizer	2-5
	Tape Synchronizer ↔ Tape Transport	2-5
	Parity Error Indication	2-6
	Write	2-6
	Search for Start of Data	2-6
	Read	2-7
	Read Jig Feature	2-7
3	Programming and Operation	3-1
	External Function Codes	3-1
	Motion and Format Codes	3-1
	Interrupt Codes	3-2
	Status Response	3-4
	Input/Output Data Formats	3-6
	Write Start of Data	3-6
	Write Block Word	3-7
	Write Data Words	3-7
	Write End of Data Word	3-7
	Search Format	3-8
	Read Format	3-8
	Operation	3-9
	Power Turn On	3-9
	Tape Loading Procedure	3-10
	Tape Unloading Procedure	3-11
	General Precautions for Tape Operations	3-12
	Manual Controls and Indicators	3-12

CONTENTS (Cont'd)

<u>Section</u>	<u>Title</u>	<u>Page</u>
4	Circuit Diagrams	4-1
	Key to Logic Symbols	4-2
	Symbol List	4-4
	Block Diagram	4-9
	Transmission Lines Between Data Channel And Controller	4-11
	Check Transmission Parity, Generate Write Parity	4-13
	Connect, Reply and Reject	4-15
	Connect Chain, Write Oscillator, Power On Master Clear	4-17
	Functions	4-19
	Interrupts	4-21
	Tape Functions	4-23
	Write Control	4-25
	O Register	4-27
	Write Registers	4-29
	Read Control	4-31
	Counter and Comparison Networks	4-33
	X Read Register	4-35
	Read Parity Check	4-37
	Write Sequence	4-38
	Write Timing	4-39
	Read Sequence	4-40
	Read Timing Diagram	4-41
	Tape Unit Selection	4-43
	Input from Tape Units	4-45
	Input from Tape Units	4-47
	Output to Tape Units	4-49
	Output to Tape Units	4-51
	Output to Tape Units	4-53
5	Parts List	5-1
	Maintenance Parts List	5-1
	Ordering of Parts	5-1

FIGURES

<u>Figure</u>	<u>Title</u>	<u>Page</u>
1-1	Special Option 60026 System Relationship	1-1
2-1	Bit Assignments on Tape	2-2
2-2	Tape Record Format	2-4
2-3	Example of Read Jig Feature	2-8

TABLES

<u>Table</u>	<u>Title</u>	<u>Page</u>
2-1	Tape Word Bit Format	2-3
3-1	External Function Codes for the Special Option 60026	3-1
3-2	Status Responses	3-4
3-3	627 Controls and Indicators	3-13
3-4	60026 Controls and Indicators	3-14

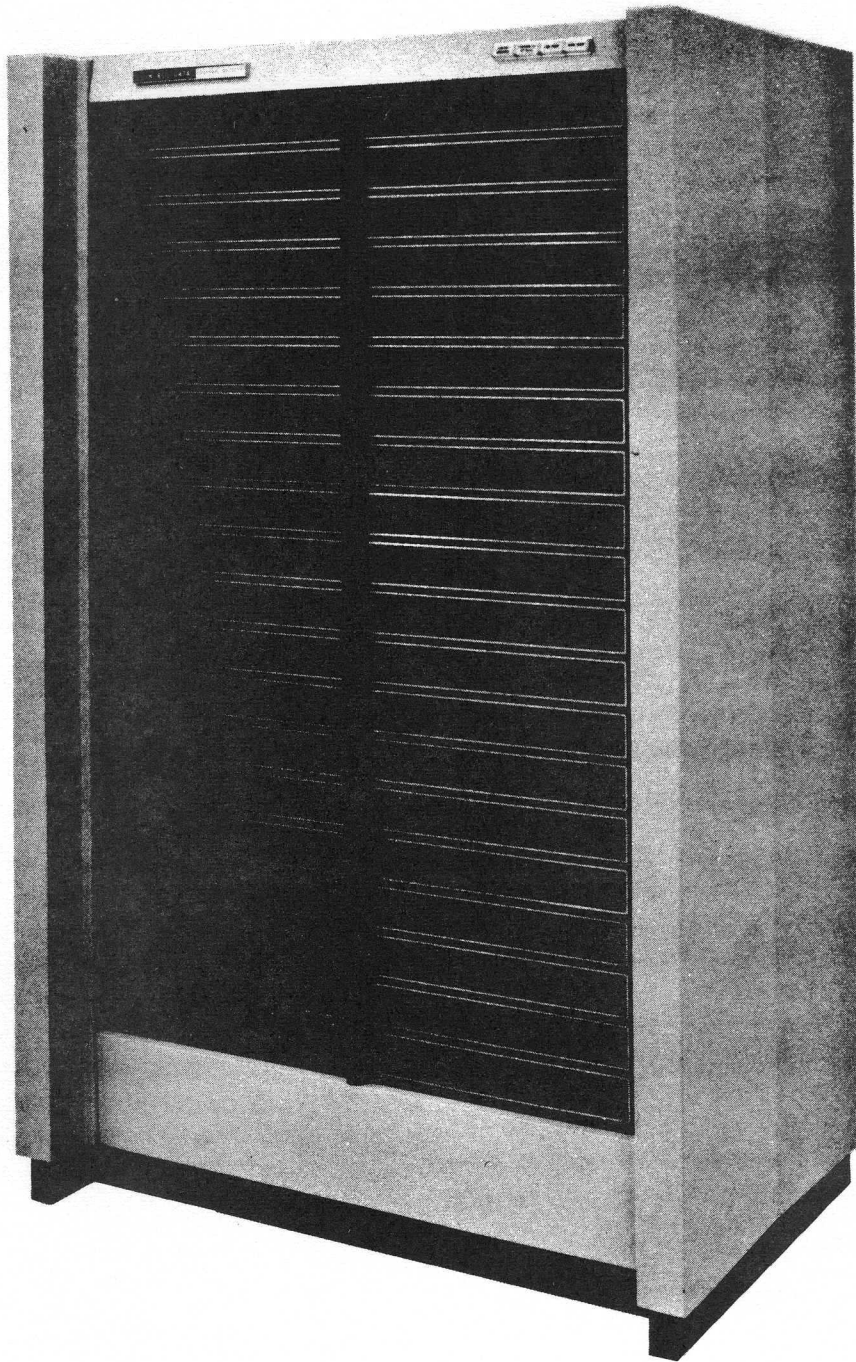

SPECIAL OPTION 60026 MAGNETIC TAPE CONTROLLER

SECTION 1

INTRODUCTION

The CONTROL DATA* Special Option 60026 Magnetic Tape Controller is an intermediate equipment which synchronizes the exchange of information between 24 bit bidirectional data channels and Control Data 627 Magnetic Tape Transports (21-track tape). The controller contains all the logic necessary for connecting the data channel and a tape unit, read and write operations, translating external functions, parity checking and generation, error detection, and status responses.

The 60026 is a single control synchronizer which connects to a 3X07 bidirectional communication channel. It can connect and control up to four transports on a one-at-a-time basis.

Figure 1-1 illustrates the location of the Special Option 60026 in a typical 3000 Series computer system.

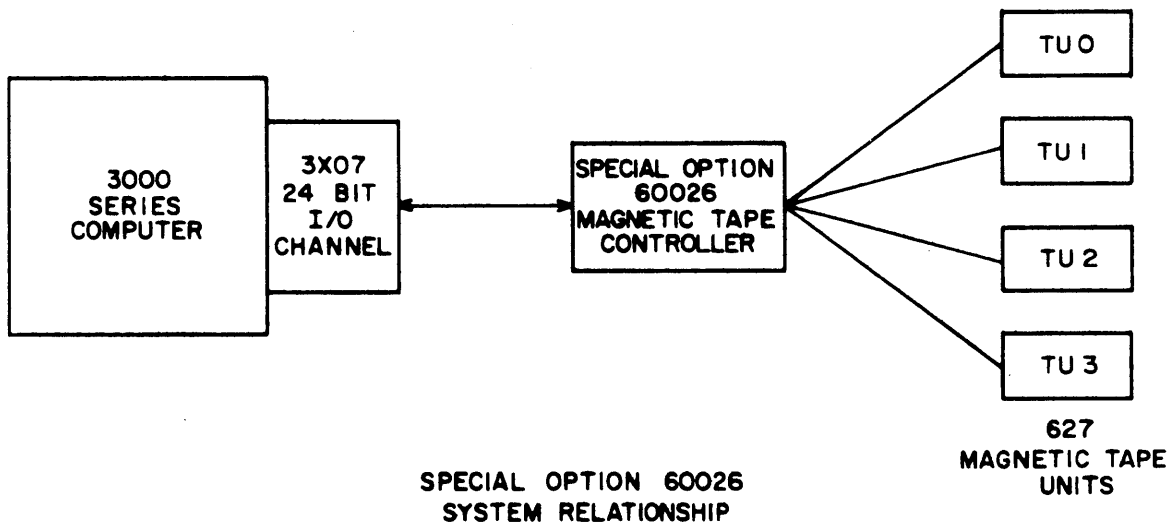

Figure 1-1. Special Option 60026 System Relationship

* Registered trademark of Control Data Corporation.



SECTION 2

DESCRIPTION

PHYSICAL DESCRIPTION

The Special Option 60026 Magnetic Tape Controller is contained in a standard Type C cabinet.

EQUIPMENT DATA

Height	75 inches
Depth	20 1/2 inches
Width	43 3/8 inches
Maximum depth, including all access doors extended	56 inches
Maximum width, including all access doors extended	120 inches
Weight	1200 pounds (approx.)
Cooling Requirements	3000 (approx.) BTU/hr.
Power consumption, 400 cycle, 208 volts, 3 phase	625 watts
Power consumption, 60 cycle, 115 volts, single phase	230 watts
Line Current, 400 cycle, 208 volts, 3 phase	2 amp/phase
Line Current, 60 cycle, 115 volts, single phase	2.4 amp
Cooling method	blower
Distance from signal cable receptacle to floor	8 1/4 inches
Distance from power junction box to floor	2 inches

FUNCTIONAL DESCRIPTION

A program using a tape operation must first select a tape unit and establish a connection. The connection is established by directing the computer to execute an external connect code. This code designates the communications channel number, the controller equipment number, and the tape unit on which the operation is to be performed. After the controller connects a tape unit, any other connection that channel makes automatically clears the previous unit connection.

Once the computer establishes a connect, the program may direct the computer to execute one or more external function instructions or perform a tape operation. During read or write operations, the synchronizer waits for the computer to initiate the operation (Read or Write signal present) and then serves as a timing and buffer wait for directing the flow of data between the tape unit and the data channel.

MAGNETIC TAPE

Information is recorded on one inch magnetic tape in 21-parallel track format (Figure 2-1). Two of these tracks are generated by the controller and used for synchronization timing (bit 9 equals clock bit) and error checking (bit 19 equals parity bit). The remaining nineteen bits represent the four distinct types of words which may be written on tape: 1) start of data (SOD) word, 2) end of data (EOD) word, 3) block word, and 4) data word. The first three words contain a "1" in bit position 18 (block bit) and are further defined by code bits in bit positions 16 and 17. The fourth word contains a "0" in bit position 18 which defines it as a data word. Data words contain a sign bit ("1" negative and "0" positive) in bit position 17 and information data in bits 0 through 16. Table 2-1 describes the four types of tape words.

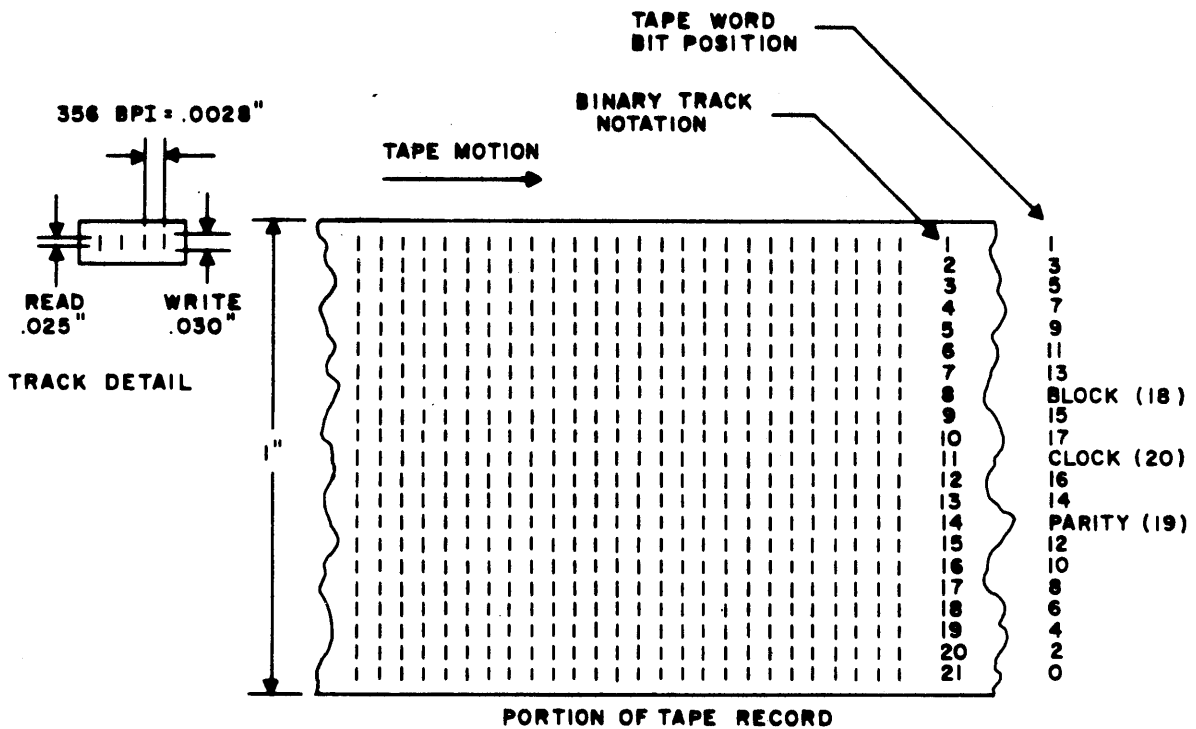

NOTE:
OXIDE SIDE UP ON DIAGRAM RECORDING
HEADS ON SAME SIDE AS OXIDE.

Figure 2-1. Bit Assignments on Tape

TABLE 2-1. TAPE WORD BIT FORMAT

Word Type	Bit Position			
	18	17	16	15 ← → 0
SOD Word	1	1	0	Address
EOD Word	1	1	1	All "1's"
Block Word	1	0	0	Address
Data Word	0	S	Information	

The tape arranges recorded data in groups called records. A preceding SOD address word (repeated several times) identifies a record; an EOD word (repeated several times) terminates a record.

The tape arranges data within a record in groups called blocks. Each block consists of a block word address and 31₁₀ data words. The block word address identifies the following block of 31₁₀ data words.

Figure 2-2 illustrates tape record and block format.

The tape records information continuously without space between blocks at a density of 356 words per inch and at a speed of 112.5 inches per second (25 usec per word). All words record a "1" bit in the clock track. The controller uses this bit for timing purposes during read operations.

The "non-return-to-zero" method is used to record information on tape. During the writing process, a magnetizing current flows through the head at all times, in one direction or the other. The direction of magnetization is not significant. A change in the direction of the magnetic flux represents a "1" bit on the tape. Using this method to record eliminates the necessity of erasing. The write current erases information previously written on tape while the new information is being recorded.

TAPE FORMAT

Each record written on tape consists of three parts: start of data (SOD) address, a block of data words (block word address and 31 data words), and end of data (EOD). The writing of all "1's" across the tape signifies the EOD. Figure 2-2 illustrates a typical record tape format. The SOD is two different lengths depending upon the position of the tape on the transport. If the tape is at the loadpoint (beginning of the reel), the SOD is recorded for 80 ms. All other SOD's on the reel are written for 3 ms.

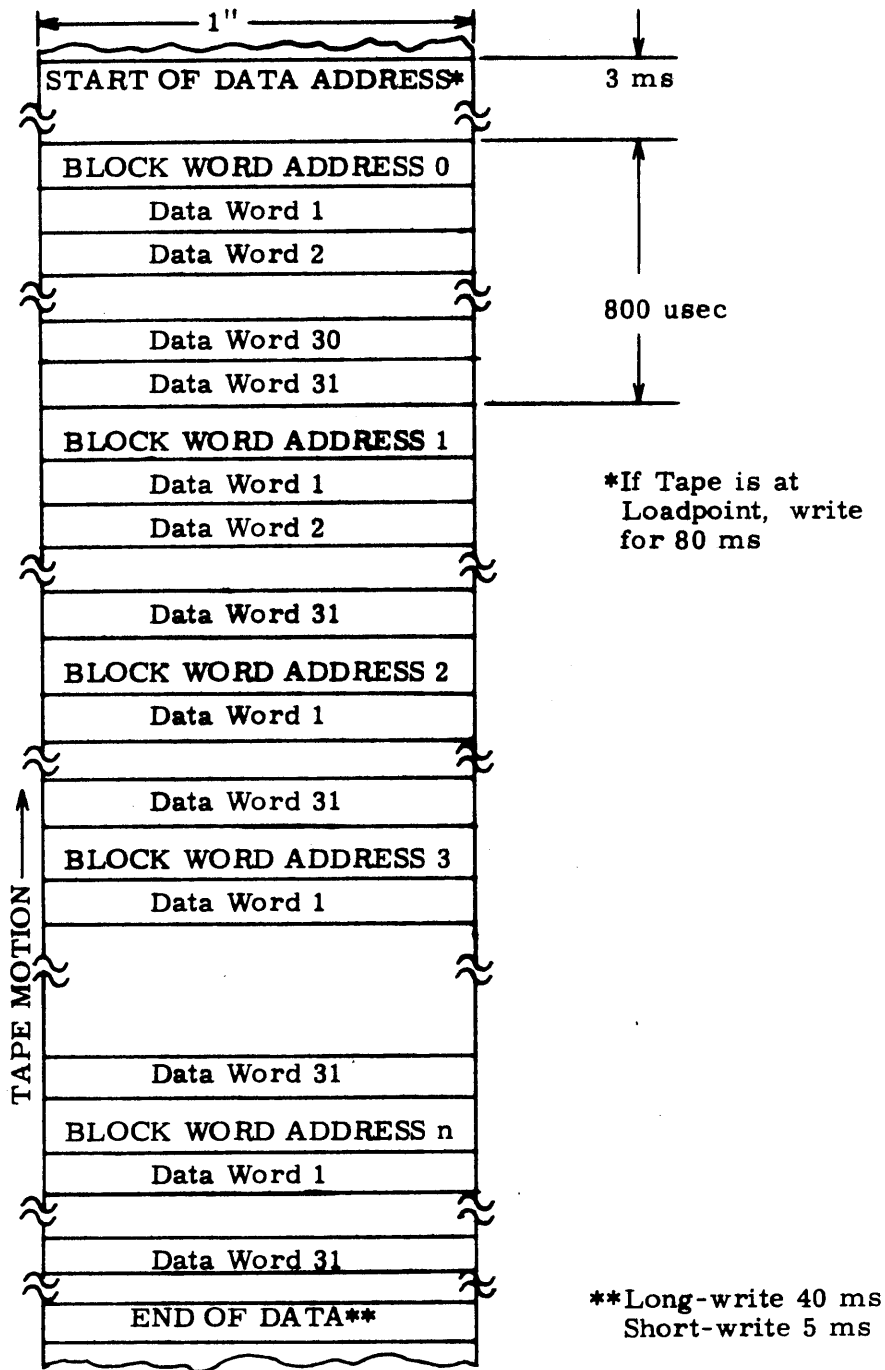

Figure 2-2. Tape Record Format

After the controller writes the SOD, it records blocks of data words in the format previously described.

At the end of each record, the EOD is recorded. The controller can write one of two lengths of EOD if the program executes the appropriate external function code prior to a write operation. Section 3 lists external function codes. If the controller selects the long EOD, it writes all "1's" on tape for 40 ms. If the controller selects the short EOD, it records all "1's" on tape for 5 ms. A Master Clear (MC) signal automatically conditions the controller to write the long EOD.

DATA TRANSMISSIONS AND PARITY

All information transmitted between the controller and the data channel is in the form of 24-bit bytes and two transmission parity bits. The data channel generates a transmission parity bit for every 12-bit byte sent to the controller. Therefore, each 24-bit byte has two transmission parity bits which the controller checks for an odd parity count. Conversely, when information is sent to the data channel, the controller generates two transmission parity bits which the data channel checks.

DATA CHANNEL ↔ TAPE SYNCHRONIZER

The lower 18 bit (0-17) positions contain write data passing from the data channel to the synchronizer. Bit position 20 contains the comparison bit and bit position 18 contains the block bit. The remaining bit positions are not used.

All 24 bits contain the read data passing from the synchronizer to the data channel. Of these 24 bits, the lower 17 bits (0-16) contain information. If the word read is a data word (block bit 18 equals "0") bit 17 (information sign bit) extends through bit 23. If the word read is a block word address (block bit 18 equals "1") bit extension does not occur. In this case, bits 0-18 are transmitted as they appear on tape and bits 19-23 are filled with "0's".

TAPE SYNCHRONIZER ↔ TAPE TRANSPORT

Information transmitted between the controller and the tape unit is in the form of 21-bit words. Bit positions 0 through 18 correspond to their respective positions in the 24-bit byte. Bit position 19 contains the parity bit. Bit position 20 is used for the Clock pulse which the controller generates during write operations. This Clock pulse provides timing which is used to read the recorded information from the tape.

PARITY ERROR INDICATION

Any tape parity errors detected by the synchronizer during a read operation cause the transfer of a special error word (60000000_g) to the data channel in place of the tape word. A manually controlled switch at location 1B058 within the chassis of the synchronizer allows the transfer of the special error word. If the switch is up, the error word is sent; if it is down, the tape word is sent to the data channel.

If a parity error occurs on a word that matches the desired first block word address, the synchronizer ignores this word and searches the remaining block word addresses in the record. Tape stops when an EOD is detected.

Parity errors detected during write operations via the automatic read-after-write error check feature cause tape parity error status (bit 9) to set. This indication is removed when status is read or via a master clear. The status check for write parity errors is valid 2.7 ms after a write is complete. This 2.7 ms delay is a function of the spacing between the write and read heads of the 627 tape transport.

WRITE

The computer can execute a write operation after it establishes the connect. When the controller receives a write signal, it first samples the binary status of the comparison bit (bit 20). This bit informs the controller whether or not the word is to be written on tape. If the comparison bit is a "1", the word is not written on tape but held in the O register as are all following words (if any) during the write operation. The comparison bit is normally set when performing a one-word write of a SOD or block word prior to a search or read operation.

If the comparison bit is a "0", the controller performs a normal write operation.

SEARCH FOR START OF DATA

Assuming the connect is established, the computer may direct the controller to locate a particular record on the tape. Execution of a Search Start of Data (forward or backward) function locates the record. However, prior to initiation of this function, the address for SOD location must be sent to the controller. Execution of a write instruction enters the address as previously explained.

When the Search SOD function is executed, the tape unit starts motion in the direction indicated by the function code. Each word on the tape is then read, placed in a comparison network and discarded by the controller until the word read is identical to the SOD address previously entered. Before a search is satisfied, the controller must read the SOD address eight consecutive times. This assures the controller that the correct SOD address has been found.

READ

Assuming that the tape is in position (at the correct SOD address or between the correct SOD address and the block intended to be read), the computer sends the controller a block word address by another write operation. The computer then sends a read signal which moves the tape forward. Although the tape unit sends all of the data that it is reading to the controller the controller does not transmit any data to the data channel until the block word address is found.

Data is then continuously sent to the computer until the end of data words are read or the computer word count equals zero.

When an EOD is detected, the unit continues to move tape forward for 3 ms and then stops. If the word count equals zero, and no EOD is detected, the computer drops the Read signal to the controller. The controller then signals the tape unit to stop forward tape motion and begins moving the tape backward. The tape moves backward far enough to be in front of the last block read and then stops. At the completion of the operation, the O register contains the address of the last block word read.

The non-stop read is performed if the controller receives the Read signal from the channel within 30 usec from the time the channel drops the Read signal. If the controller does not receive the Read signal within 30 usec tape motion stops and the controller will accept the following read only after the tape unit becomes not busy. Use of the non-stop read saves 5 ms.

READ JIG FEATURE

If the Read signal drops within a record, the controller dictates 5 ms of reverse tape motion. Since the controller contains the block word, as each block is read the jig provides the controller with the ability to resume reading tape at the point in the record where the Read signal dropped. To utilize this feature in reading partial records

the programmer must instruct the controller to read the next block word before dropping the Read signal. The controller then resumes reading at the correct point (Figure 2-3).

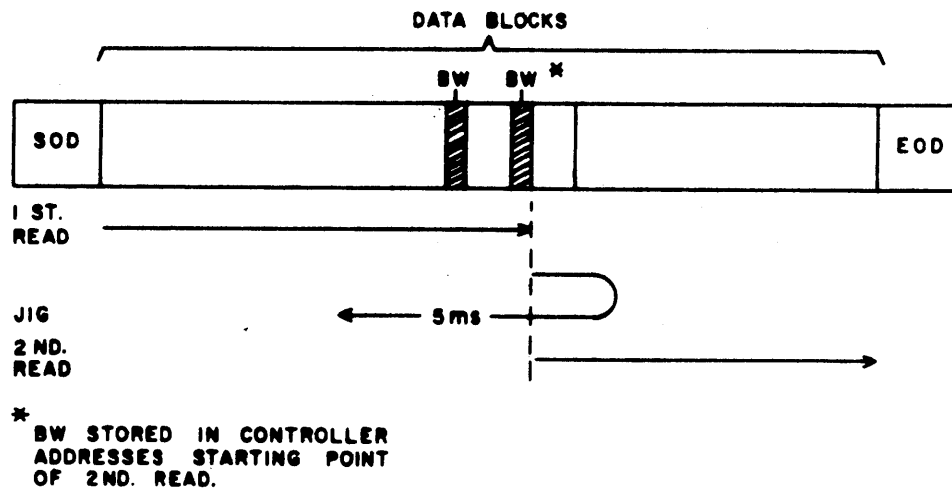

Figure 2-3. Example of Read Jig Feature

SECTION 3

PROGRAMMING AND OPERATION

EXTERNAL FUNCTION CODES

The 60026 Controller does not accept or recognize function codes unless the channel is connected. Function codes should be selected before starting an operation; i. e. before the channel becomes active and the data transmission takes place. This assures that all selections have been made and applicable action will take place during or at the end of the preceding operation (Write, Read or Search). All external function codes applicable to the controller are listed in Table 3-1.

TABLE 3-1. EXTERNAL FUNCTION CODES FOR THE SPECIAL OPTION 60026

MOTION AND FORMAT	
0000	Release
0005	Clear
0010	Rewind
0011	Rewind Unload
0013	Search Start of Data Forward
0014	Search Start of Data Backward
0030	Long End of Data
0031	Short End of Data
INTERRUPTS	
0020	Interrupt on Normal End of Operation
0021	Release Interrupt on Normal End of Operation
0022	Interrupt on Ready and Not Busy
0023	Release Interrupt on Ready and Not Busy
0024	Interrupt on Error
0025	Release Interrupt on Error
0026	Interrupt on Begin Data Transfer
0027	Release Interrupt on Begin Data Transfer

MOTION AND FORMAT CODES

Release (0000)

A Release code clears the existing tape unit connection.

Clear (0005)

Same as Release (0000).

Rewind (0010)

A 0010 code rewinds the tape at high speed (over 320 inches/second) to loadpoint. Any further Rewind instructions when tape is at loadpoint have no effect. A Loadpoint signal appears on a status line when the operation is complete.

Rewind Unload (0011)

A 0011 code rewinds tape at high speed to tape unload condition and stops. All further operations on this tape are locked out until the tape has been reloaded manually.

Search Start of Data Forward (0013)

Search Start of Data Backward (0014)

If the program contains a search function, the computer must first send the controller a Start of Data address. A Write operation accomplishes this. The search function code (Forward or Backward) 0013/0014 is then initiated to start tape motion. When the controller recognizes the particular Start of Data address, tape motion stops. A Start of Data (SOD) signal appears on a status line when the operation is complete. If no SOD address is detected, tape motion continues until loadpoint or end of tape markers are reached and then terminates.

Long End of Data (0030)

This function code gears the controller to write the End of Data word (all "1's") on the tape for 40 ms.

Short End of Data (0031)

The 0031 code gears the controller to write the End of Data word (all "1's") on the tape for 5 ms.

INTERRUPT CODES

All desired interrupt selections must come before a Read or Write operation, but can occur during any other operation. The eight-position Equipment Designator switch determines on which line the Interrupt signal is transmitted. For example, if the Equipment Designator switch is set to 5, any interrupts are transmitted on

interrupt line 5. Each Release Interrupt code clears its corresponding selection. Any new Interrupt code (either a set or a clear) or a Master Clear clears the Interrupt signal.

NOTE

When the selected condition for interrupt occurs in a tape unit, that unit must be connected. If the tape unit is not connected, the interrupt does not occur. For example, interrupt on Ready and not busy is selected and a Rewind is executed. During rewinding, another tape unit is connected to the controller. This disconnects the unit that is rewinding, and it does not interrupt when the unit becomes Ready and not Busy. If the unit that was rewinding is reconnected, and it is or becomes Ready and not Busy, the interrupt occurs.

Interrupt on Normal End of Operation (0020)

Release Interrupt on Normal End of Operation (0021)

The 0020 code selects the controller to send an Interrupt signal out to the channel when a search SOD function is satisfied or when read or write operations are complete. Release Interrupt on Normal End of Operation (code 0021) clears this condition.

Interrupt on Ready and Not Busy (0022)

Release Interrupt on Ready and Not Busy (0023)

The 0022 code selects the controller to send an Interrupt signal out to the channel when the Ready and Not Busy condition is sensed. Release Interrupt on Ready and Not Busy (code 0023) clears this condition.

Interrupt on Error (0024)

Release Interrupt on Error (0025)

The 0024 code selects Control X to send an Interrupt signal out on the channel when any one of the following conditions occurs:

- 1) Block Length Error
- 2) Loadpoint Sensed while searching SOD reverse
- 3) End of Tape Sensed
- 4) Lost Data

Release Interrupt on error code (0025) clears this condition.

Interrupt on Begin Data Transfer (0026)

Release Interrupt on Begin Data Transfer (0027)

The 0026 code selects the controller to send an Interrupt signal out on the channel when the addressed block word is read. Release Interrupt on Begin Data Transfer (code 0027) clears this condition.

STATUS RESPONSE

Twelve status conditions for the controller and tape unit are available to the computer after a connect has been established. Table 3-2 lists the Status Responses available to the computer for the controller and the bit position of each status condition in association with the bit sensing instruction.

READY (XXX1)

The Ready status line is activated when the connected tape unit is in a Ready condition. When the tape unit is manually controlled, the Ready signal is not present.

TABLE 3-2. STATUS RESPONSES

	STATUS	BIT POSITION
XXX1	Ready	0
XXX2	Channel/ Equipment/ Unit Busy	1
XXX4	Write Enable	2
XX1X	Start of Data (Search satisfied)	3
XX2X	End of Data	4
XX4X	Begin Data Transfer	5
X1XX	Normal End of Operation	6
X2XX	End-of-Tape or Loadpoint	7
X4XX	Block Length Error	8
1XXX	Tape Parity Error	9
2XXX	Not Used	10
4XXX	Lost Data	11

CHANNEL, CONTROLLER, OR TAPE UNIT BUSY (XXX2)

The controller activates this status line when it is reading or writing from/on tape. The signal is also present when the connected tape unit is in a Busy condition due to a tape motion function, and when the channel is busy.

WRITE ENABLE (XXX4)

A signal is present on the Write Enable status line only when the file protection ring is on the tape reel. When this signal is absent, it is impossible to write on tape; however, information may be read from tape.

START OF DATA (XX1X)

The controller activates the Start of Data status when a Search (SOD) function is satisfied. The controller removes the signal from the line when a new function or operation is selected.

END OF DATA (XX2X)

The End of Data signal is present when an End of Data word is sensed after a block word has been read.

BEGIN DATA TRANSFER (XX4X)

This line is activated when the addressed block word is read from the tape. The computer must first issue a Write instruction to enter the address of the desired block word. Then a Read instruction is executed. When the desired block word is sensed, the status signal will be present. If the Begin Data Transfer status is not available upon the termination of a read operation, the controller has not transferred data to the data channel.

NORMAL END OF OPERATION (X1XX)

The controller activates this status line when 1) a search is terminated by finding the SOD, 2) the End of Data is read during a read operation, or 3) the channel goes Not Busy.

END OF TAPE OR LOADPOINT (X2XX)

This status signal is present on the line when the metal leader on the end of tape reel is positioned on the tape unit end of tape sensor, or when a loadpoint marker is detected at the tape unit.

BLOCK LENGTH ERROR (X4XX)

This status line is activated whenever the number of data words in a block is not equal to 31_{10} . This bit is set if an error is detected during read or write operations and is cleared when status is read.

PARITY ERROR (1XXX)

This status line is activated whenever a tape parity (vertical) error occurs. The signal is removed when a new read or write operation is executed or by a new connect operation or whenever an external status instruction is performed by the computer.

NOT USED (2XXX)

LOST DATA (4XXX)

This signal appears during a write operation if the tape controller is ready to accept information, but the Data signal is absent (Write signal present). When the Lost Data signal appears during a write operation, tape motion stops. Further write operations are impossible until a new Function or Connect code clears the Lost Data signal.

The Lost Data signal also appears during a read operation when the tape controller has data ready for output, but the Data signal is absent (Read signal present). If the Lost Data signal appears during a read operation, tape motion stops. Further Read operations are impossible until a new Function or Connect code clears the signal.

INPUT/OUTPUT DATA FORMATS

The following word formats illustrate the coding of computer input/output words during write, search, and read operation.

WRITE START OF DATA

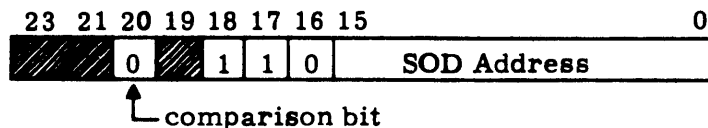

The start of data (SOD) address is in the 16 low order bit positions of the computer output word. The controller decodes bit positions 18, 17, and 16, to indicate that the word received is a SOD address. Bit 20 is zero indicating that this SOD address is to be written on the tape.

WRITE BLOCK WORD

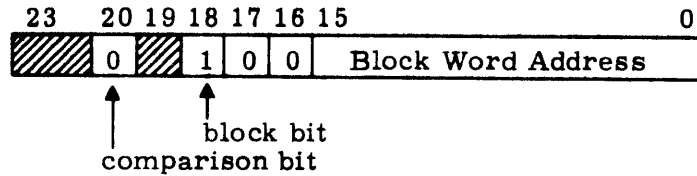

The block word address is in the 16 low order bit positions (0-15) of the computer output word. The controller decodes bit positions 18, 17, and 16 indicating that the word received is a block word address. Bit 20 is a zero indicating the word is written on tape.

WRITE DATA WORDS

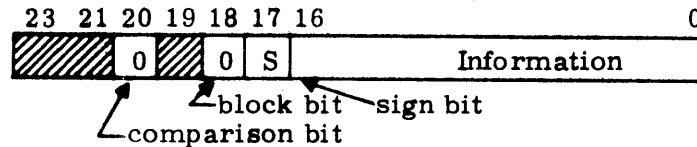

Data words are in the lower 17 bits of each computer output data word to the controller. Bit 18 equals 0 indicates to the controller that a data word is contained in bits 0-17. Bit 17 is the sign bit for the data word. Bit 20 is zero indicating the data word is written on tape. Each data block must contain 31_{10} data words.

WRITE END OF DATA WORD

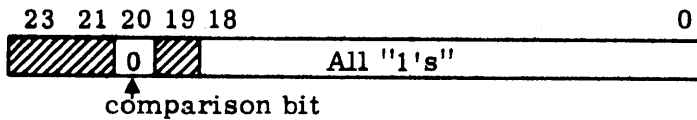

When the last data word of a record is written, the end of data word is written. Bit positions 0 through 18 of the output word contain all "1's". Bit 20 is "0" indicating that the output word is written on tape.

SEARCH FORMAT

Prior to the initiation of a search SOD function, the SOD address must be transmitted from the computer to the controller via a one word write operation. The format of the output word is shown in the following diagram.

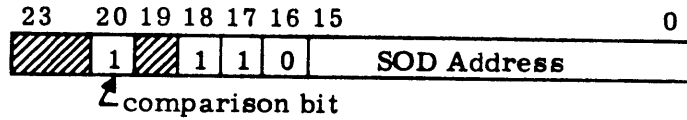

Upon execution of a write instruction, the controller loads the contents of the output word into the O register, but does not start tape motion. Bit 20 set to "1" indicates to the controller that a Search function will follow. The "1" bit in position 20 causes the controller to inhibit the write gates to the tape. The controller decodes bits 18, 17, and 16 of the output word to indicate that the contents of bit positions 0 through 15 contain a SOD address.

READ FORMAT

Prior to the initiation of a read operation, the computer must transmit the starting block word address to the controller via a one word write operation. The format of the output word is shown in the following diagram.

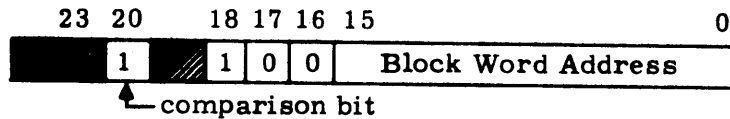

Upon execution of the write instruction, the controller loads the contents of the output word into the O register, but does not start tape motion. Bits 18, 17, and 16 of the output word are decoded at the controller to indicate that bits 0-15 contain a Block word address. Bit 20 is a "1" indicating the output word is not to be written on tape.

The instruction following this write operation is a read instruction. After the controller executes the read instruction, it initiates forward tape motion. When it detects the desired block word address, it initiates a read data transfer to the computer. The first word transferred to the computer is the correct block word address.

Input Word Format

Input words may be data words or block words as determined by the block bit (bit 18) recorded on tape.

If a parity error occurs on any input word except the first block word in a group of blocks, the word in which the parity error occurred is replaced by a unique input word. This unique word contains "1's" in bit positions 23 and 22 and all other bits are "0's" (60000000_8).

If a parity error occurs on a block word while the controller is looking for the desired block word, the block word is ignored. If the controller does not find the correct block word the tape moves to the EOD, sends a Disconnect signal to the computer, and stops. No data is transferred in this case.

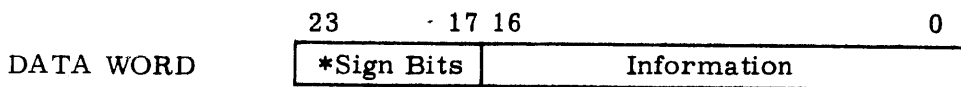
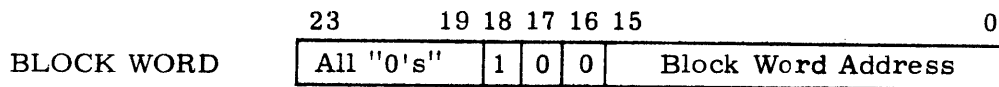

*Bit 17 extended to all bits through 23

OPERATION

This section contains general information required for operating the 627 Magnetic Tape Transport and includes the functions of the controls and indicators located on the 60026 controller. For a detailed description of the tape unit, refer to the 627 Magnetic Tape Transport/Reference Manual (Control Data publication number 40807800).

POWER TURN ON

The power to the Special Option Magnetic Tape Controller turns on at the System Power Distribution Panel. To initially energize the 627 tape unit use the following procedure:

- 1) Open doors at back of cabinet.
- 2) Push the Main Power circuit breaker (On power supply) to the Up position. A neon indicator located directly below the circuit breaker should light. (If the neon fails to light, notify maintenance).

- 3) Push the remaining circuit breakers on the power supply to the Up position.
- 4) Place the Power switch on the maintenance panel in the On (Up) position and hold for about two seconds, then release.
- 5) The Power indicator on the front control panel should turn on. If the indicator fails to light, turn off all power and repeat the procedure starting with step 2 above. (If the indicator on the front control panel fails to light after repeating the procedure, notify maintenance).
- 6) Close the back doors.

NOTE

The Power switch on the operator's front control panel is used only to remove power from the unit. Once the switch is pressed, the above procedure must be repeated to apply power to the unit.

TAPE LOADING PROCEDURE

- 1) Lower the front sliding door to its lowest position.
- 2) Remove the file reel from the plastic tape container, handling it by the center hole and edges only. Do not squeeze the sides together. Keep the tape container closed at all times to prevent contamination.
- 3) Check the file protection ring on the back of the supply reel. If the operation to be performed with the tape is a read, the ring is not necessary. If the file is to be written on, make sure the ring is in place.
- 4) Mount the file reel on the supply reel hub (right side when facing front of transport). For proper reel alignment, push the reel firmly against the hub stop before tightening the hub knob. If the supply reel contains a file protection ring, the overhead lights should be on, indicating that a write operation may be performed. If the lights are not on, notify maintenance.
- 5) Make sure that the tape load arms are in the Up position.
- 6) Pull sufficient tape from the supply reel to reach the take-up reel. Thread the tape on the outside of the supply tape load arm and over the head assembly. Take the end of the fifteen foot metal leader attached to the take-up reel and make the (quick-disconnect) connection to the end of the

supply reel tape. To make the connection, slip the two tabs on the end of the supply tape into the two slots provided on the end of the take-up reel tape. Make sure the tape is not twisted and that it is threaded over the outside of the take-up load arm.

CAUTION

During tape loading, be sure to connect the leader on the LEFT side of the Read/Write heads when facing the unit.

- 7) Slide the tape under the head assembly.
- 8) Snap tape load arms down.
- 9) Place the Equipment Designator switch to one of the ten positions (0 through 7 or one of the standby positions) to assign a logical program selection address.
- 10) Press the Load switch. The tape drops into the vacuum columns and stops on the loadpoint; the Load indicator turns on. There are three tape sensors located in the vacuum columns. The one in the upper left corner of the left column (facing the front of tape unit) senses the beginning of the tape. The loadpoint sensor is located about five inches down on the right side of the left column, and the end of tape sensor is on the upper right corner of the right column. A fifteen foot metal leader is attached to each end of the reel for the purpose of sensing the beginning and end of the tape. The tape loadpoint is directly behind the two quick-disconnect tabs on the supply reel tape. If the Load indicator does not turn on, notify maintenance.
- 11) To place the tape unit under computer control, press the Ready pushbutton and the Ready indicator should light.
- 12) Raise the sliding glass door.

TAPE UNLOADING PROCEDURE

- 1) Press the Clear switch to remove the computer control of the tape unit.
- 2) Press the Unload switch. The tape is automatically drawn from the take-up reel until the loadpoint is sensed and stops. The Unload light turns on.

- 3) Lower the sliding glass door.
- 4) Rotate the supply reel in a counterclockwise direction until the quick-disconnect is out of the vacuum column. Carefully remove the tabs on the supply reel tape and from the take-up reel end. Manually rotate the supply reel in a counterclockwise direction until all the tape is on the reel. Rotate the take-up reel in a clockwise direction until all of the metal leader is out of the vacuum column.
- 5) Loosen the supply reel hub knob and remove the reel.
- 6) Check the reel for proper labeling and place it in the plastic tape container.

GENERAL PRECAUTIONS FOR TAPE OPERATION

- 1) Do not allow the tape to fall on the floor. The area in which the tape is used should be kept clean. Dust or ashes can damage the tape permanently.
- 2) Handle the tape reel near the hub. Never rock the reel by grasping the outer edge. If a tape break occurs, divide the reel into two smaller reels. Splicing is not recommended except for emergency data recovery.
- 3) If it is difficult to remove the reel, break the bond between the reel and the hub by placing palms of hands along the edges of the reel and rotating it.
- 4) Always keep the sliding glass door shut except while loading or unloading tape.
- 5) Always keep the plastic tape container closed to prevent contamination from dust and ashes.

MANUAL CONTROLS AND INDICATORS

Table 3-3 describes the manual controls and indicators for operating the 627 Magnetic Tape Transport. The controls and indicators associated with the 60026 Controller are described in Table 3-4.

TABLE 3-3. 627 CONTROLS AND INDICATORS

NAME		FUNCTION
Power	S* I**	Removes power from all components and power supplies. Power is available to components and power supplies.
Forward	S I	Moves tape from right to left at 112.5 ips. Motion stops when end of tape marker is sensed. Tape is moving forward at 112.5 ips.
Reverse	S I	Moves tape from left to right at 112.5 ips. Motion stops when loadpoint marker is sensed. Tape is moving in reverse direction at 112.5 ips.
Rewind	S I	Rewinds tape at high speed (over 320 ips average). Motion stops when the loadpoint marker is sensed. Tape is moving in reverse direction at high speed.
Unload	S I	Moves tape at high speed to load position. Pad retracts and vacuum is removed from tape columns. Tape unit is in unload status.
Load	S I	Pulls tape into column, moves tape forward, then searches reverse for loadpoint marker. Motion automatically stops when marker is sensed. Tape is at loadpoint marker.
Ready	S I	Places unit under computer control. Unit is placed under manual control only when master cleared locally or a rewind unload selected by the controller. Unit is under computer control.
Clear	S I	Master clears all previous settings and conditions. Stops (immediately) tape motion. New manual selections are necessary to reselect tape unit and/or operation required. Unit is cleared.
Equipment Designator	S I(White) I(Red)	Ten-position switch; 0-7 provide input designation while two standby positions disconnect unit from external control. Unit select status indicator number 1. Unit select status indicator number 2.
Overhead Lights	I	File protection ring is on reel (unit can write) and tape unit is not in the unload position.

*Switch
**Indicator

TABLE 3-4. 60026 CONTROLS AND INDICATORS

NAME		FUNCTION
Equipment Designator	S*	Eight-position switch (0 through 7) associated with the controller. The setting designates the equipment number N. Interrupts coming from the controller are transmitted through one of the eight interrupt lines corresponding to the Equipment Selection switch setting.
	I** (White) I (Red)	Controller connected to a computer channel. Transmission parity error occurred.
Interrupt	I	Interrupt occurred after an interrupt function was programmed.
Write	I	Write operation being performed.
Vertical Parity	I	Tape parity (vertical) error occurs.
Block Length Error	I	31 ₁₀ words not present in data block.
Error Word Transfer	S	A manually controlled switch at location 1B058 within the chassis of the synchronizer allows the transfer of the special error word. If the switch is up, the error word is sent; if down, the tape word is sent to the data channel.

*Switch
**Indicator

SECTION 4
CIRCUIT DIAGRAMS

Logic diagrams represent a symbolic approach to electronic schematics. By using symbols to represent building block circuits, the diagram becomes easy to read if the reader understands the function of the symbols. In Control Data Corporation logic, two signals, a logical 0 ("0") and logical 1 ("1"), are the possible input or output conditions of a circuit. A circuit with an output of "1" is "up" and a circuit with an output of "0" is "down". Detailed descriptions of logic symbols and their associated building block circuit cards are contained in the appropriate printed circuit manual (1604 and 3600 Card Types). Refer to the Literature Distribution Center Catalog for the publication number and latest revision level.

STANDARD LOGIC SYMBOLS

Standard logic diagram symbols for Control Data equipment using 1604- or 3600-type cards are inverters, flip-flops, control delays, capacitive delays, inductive delays, and line drivers and receivers.

Inverters

An inverter is a logic element which provides an output that is an inversion of its input. When more than one input is provided to an inverter, "1's" take precedence over "0's" and drive the output of the inverter to "0". Because any "1" input of several inputs drives the output to a "0", an inverter may be considered an inverting OR (NOR) gate when more than one input is present.

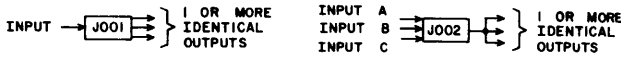

Figure 1. Inverter Symbols

Acceptable conventions for showing multiple OR inputs are given in Figure 2.

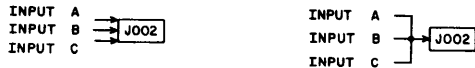

Figure 2. OR Circuit Conventions

An AND gate requires that all its inputs be "1's" in order that its output be a "1". If one or more of the inputs to an AND gate are "0", the output is a "0". Figure 3 illustrates conventions for showing AND gates feeding an inverter.



Figure 3. AND Circuit Conventions

Figure 4 illustrates a combination AND/OR input.

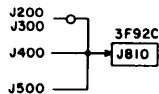

Figure 4. AND/OR Circuit Convention

KEY TO LOGIC SYMBOLS (STANDARD 1604 OR 3600 CARD TYPES)

Flip-Flops (FF)

The flip-flop (FF) is a storage device with two stable states - designated as Set and Clear - and is composed of two or more inverters. The logic symbols (Figure 5) are formed by the combination of inverter symbols. By convention, Set inputs and outputs are shown in the upper part of the symbol and Clear inputs and outputs are shown in the lower part of the symbol.

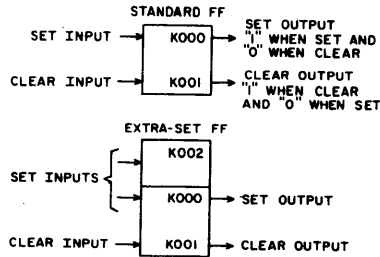

Figure 5. Flip-Flop Symbols

Figure 6 illustrates the interconnection of inverter symbols to form a flip-flop symbol. The term numbers assigned to each flip-flop are the term numbers of the internal inverters as seen by comparing the terms in Figure 5 with those in Figure 6. Notice that the Set output is the output of inverter K001, and the Clear output is the output of inverters K000 and K002.

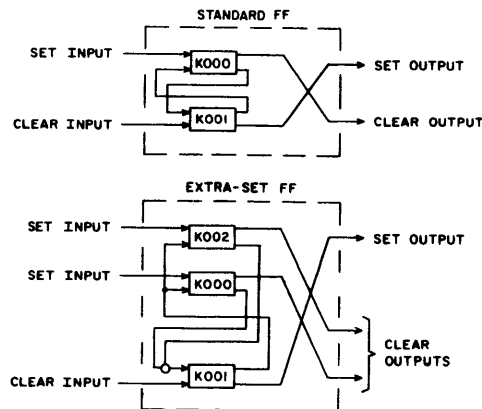

Figure 6. Internal Inverter Connections for a Flip-Flop

Control Delay

A control delay is a timing device consisting of an H term which receives the input and one or more V, Y, or N terms to provide the outputs. The H term is essentially a flip-flop with controlled feedback and occupies an entire printed circuit card. The output term(s) are inverter(s) located elsewhere on the logic chassis. The "1" outputs from a control delay are clocked pulses which are delayed one phase time from the "1" inputs. Clock inputs are not shown on the logic diagrams for any H, V, Y, or N terms; these terms, which control the start and duration of the delayed output pulses, may be found in the Equation Summary. Figure 7 illustrates two representative forms of the control delay symbol, with possible inputs and outputs labeled. Figure 8 shows the electrical connections for the two forms.

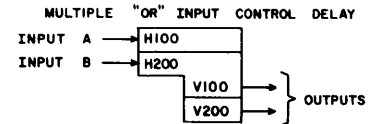
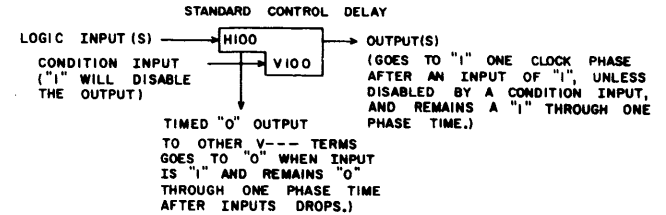

Figure 7. Control Delay Symbols

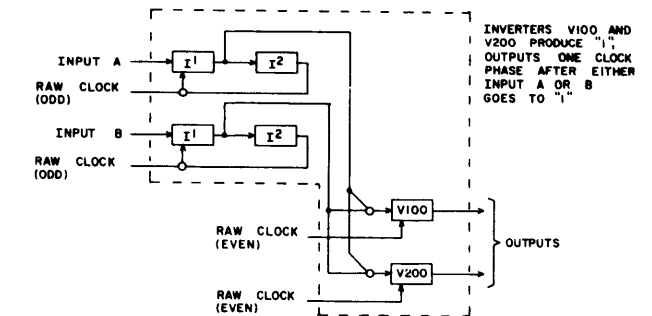
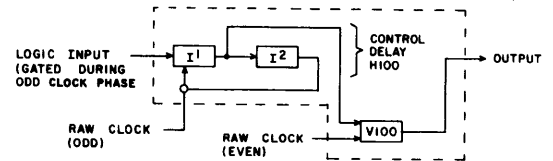

Figure 8. Electrical Connections for Control Delay

Control delays may have multiple inputs and/or multiple outputs. When a control delay has multiple output terms (i.e., more than one V, Y, or N term), each output term may have a separate conditioning input.

Capacitive Delays

A capacitive delay is used to delay the "1" input to a logic element. ("0" inputs are not affected by the delay.) Capacitive delays may be active or passive, depending upon whether or not transistors are used as part of the delaying circuit. Delay periods are checked by using a dual-trace scope connected to the input and output of the delay producing element. The actual connection points for the scope and probes vary for different cards and should be determined by referring to the Printed Circuit Manual.

Active delays may be recognized by the circuit letter always present as part of the card location. Pin numbers are also shown when external wiring is needed to connect the proper capacitance. In Figure 9, the pluggable delay uses this wiring to connect to capacitors on the same card. In the third example, this wiring connects to capacitors located on two separate capacitor cards.

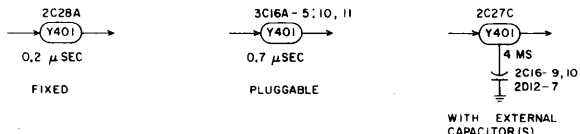

Figure 9. Active Capacitive Delays

All passive capacitive delays (Figure 10) are formed by wiring grounded capacitors, located on one or more capacitor cards, as an AND input to the affected logic element. For this reason, all passive delays show pin numbers to provide this external wiring data.

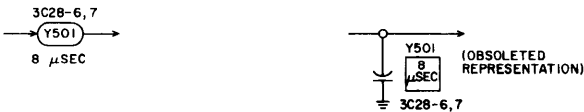

Figure 10. Passive Capacitive Delays

Capacitive delays may be adjustable or nonadjustable, depending on the card type and/or the external wiring connections on the card. When it is necessary to adjust the delay period in order to obtain specified circuit operation (usually done by varying a potentiometer in the RC network), a diagonal arrow is added to the delay symbol as shown in Figure 11.

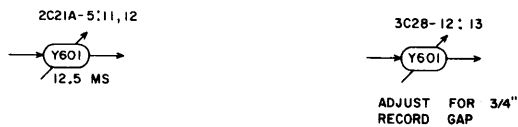

Figure 11. Adjustable Capacitive Delays

Inductive Delays

An inductive delay is used to delay either the "1" or "0" input to a logic element or as a tapped delay line for timing of operations. The symbol for this delay is an elongated oval with a double vertical line just within the input end of the oval. When used as a tapped delay line, the inductive delay is terminated in its characteristic impedance. Inductive delays are identified

in the same manner as capacitive delays (except for the vertical lines) unless they are used as delay lines. On multi-section cards where no identifying circuit letters are present, pin numbers are shown adjacent to the input and output arrows. Figure 12 shows both kinds of inductive delays.

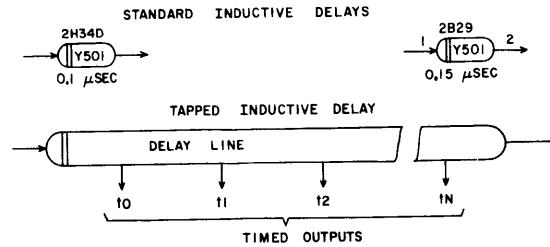

Figure 12. Inductive Delays

Line Drivers/Receivers

Voltage levels used to represent "1's" and "0's" on cables are different from those used for internal logic. The level shift to and from internal logic is made by line drivers and line receivers. These cards may be considered as inverting the signal electrically, but not logically. The letters commonly associated with these cards are L & M (1604) and R & T (3000 Series). A 3000 Series Receiver may also be used to perform a logical inversion by swapping the twisted pair wires. This usage is indicated by a circle on the input side of the symbol. In Figure 13, "1's" and "0's" have been added to clarify the logic states; they are not part of the symbol.

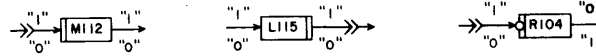

Figure 13. Typical Line Driver/Receiver Symbols

NON-LOGIC CONVENTION

The use of the double vertical bar, as shown in Figure 13, denotes a shift in signal voltage level from that used in internal logic. The double bar appears on the input or output side of the symbol, depending on which side connects to the non-logic-level signal. No particular voltage level is implied by the double bar - only that it is non-logic.

JACK ASSIGNMENTS

Each numbered term in the logic diagrams contains a jack assignment showing the physical location of that hardware element and the test point (circuit section) associated with it. For some card types, the test point letter is replaced by a pin number. For these cases, a card extender must be used in order to test that section of the card. Also, some symbols show no test point. This is because the entire card is used for one purpose (e.g. a single inverter, FF, or control delay). Figure 14 illustrates the inverter J001, with 2D12A representing its jack assignment.

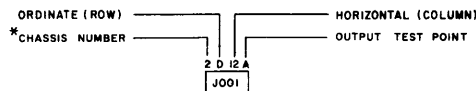

*When most or all jack assignments are located on one chassis, the chassis numbers for that chassis are omitted. All multi-chassis devices include a chassis number as part of each jack assignment.

Figure 14. Jack Assignment Scheme

CABLE IDENTIFICATION

Cable connections are represented by the MIL-STD-15 symbol and identified as to connector location and pins used, as shown in Figure 15.

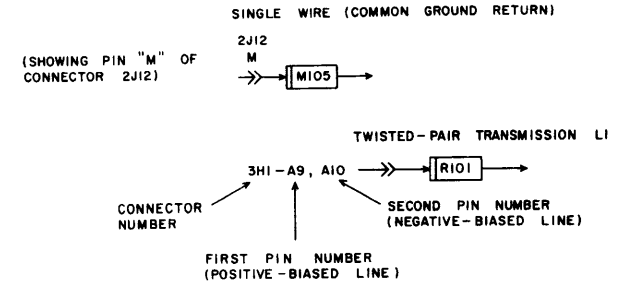

Figure 15. Cable Connections

SPECIAL LOGIC SYMBOLS

Nonstandard elements (special logic and/or non-logic elements) are represented by a special circuit symbol (generally a rectangle as shown in Figure 16). The special circuit symbol always shows the symbol designation, jack location, and the card type. Supplemental information may also be shown such as in the case of special delay cards which indicate the delay period. For detailed information refer to the specific card type in the appropriate Printed Circuit or Logic Module Manual.

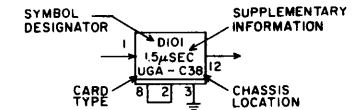

Figure 16. Symbol for Special Circuits

INPUT/OUTPUT DESIGNATIONS

Where several pages of logic are involved, a symbol index and term list (side cars) are incorporated within the manual. Also in certain instances such as special card types or on equipments for which no equation summary exists (as for peripheral devices) input and output pin numbers are indicated on each logic element as are the output destinations of the elements (Figure 17).

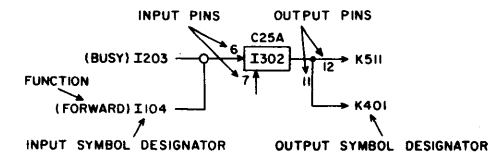

Figure 17. Input/Output Designations

SYMBOL LIST

TERM	SHEET	TERM	SHEET	TERM	SHEET	TERM	SHEET	TERM	SHEET	TERM	SHEET	TERM	SHEET	TERM	SHEET
A000	1	C000	10	C061	10	D022	5	E010	11	H000	13	I012	3	I800	4
A001	1	C001	10	C062	10	D023	5	E011	11	H001	13	I015	3	I801	4
A002	1	C002	10	C063	10	D024	5	E012	11	H002	13	I017	3	I803	4
A003	1	C003	10	C064	10	D025	5	E013	11	H003	13	I018	3	I804	4
A004	1	C004	10	C065	10	D026	5	E037	3	H004	13	I019	3	I805	4
A005	1	C005	10	C066	10	D027	6	E038	3	H005	13	I020	5	I807	4
A006	1	C006	10	C067	10	D028	5	E040	11	H006	13	I021	5	I810	4
A007	1	C007	10	C068	10	D029	3	E041	11	H007	13	I022	16	I811	4
A008	1	C008	10	C069	10	D030	5	E042	11	H008	13	I026	16	I900	21
A009	1	C009	10	C070	10	D031	8	E043	11	H009	13	I030	16		
A010	1	C010	10	C071	10	D032	5	E044	11	H010	13	I031	16	J000	5
A011	1	C011	10	C072	10	D033	3	E045	11	H011	13	I032	16	J001	5
A012	1	C012	10	C073	10	D034	8	E046	11	H012	13	I033	16	J002	5
A013	1	C013	10	C074	10	D036	5	E047	11	H013	13	I034	16	J003	5
A014	1	C014	10	C075	10	D037	5	E050	11	H014	13	I050	16	J004	5
A015	1	C015	10	C076	10	D038	5	E051	11	H015	13	I051	16	J005	5
A016	1	C016	10	C077	10	D039	3	E052	11	H016	13	I052	16	J006	5
A017	1	C017	10	C078	10	D041	7	E053	11	H017	13	I053	16	J007	5
A018	1	C018	10	C079	10	D042	7	E054	11	H018	13	I122	16	J009	5
A019	1	C019	10	C080	10	D043	7	E055	11	H019	13	I126	16	J010	5
A020	1	C020	10	C081	10	D046	7	E056	11	H050	13	I130	16	J011	5
A021	1	C021	10	C082	10	D047	3	E060	13	H051	13	I131	16	J014	5
A022	1	C022	10	C083	10	D048	7	E061	13	H052	13	I132	16	J015	5
A023	1	C023	10	C084	10	D049	6	E062	13	H053	13	I133	16	J016	5
A024	1	C024	10	C085	10	D050	7	E063	13	H054	13	I134	16	J017	5
A025	1	C025	10	C086	10	D051	6	E064	13	H055	13	I150	16	J018	5
A026	1	C026	10	C087	10	D052	7	E065	13	H056	13	I151	16	J019	5
A028	1	C027	10	C088	10	D053	7	E073	11	H057	13	I152	16	J025	6
A029	1	C028	10	C089	10	D054	7	E074	11	H058	13	I153	16	J026	5
A030	1	C029	10			D056	7	E087	11	H059	13	I222	16	J027	5
		C030	10	D000	5	D058	7	E088	11	H060	13	I226	16	J028	6
H000	12	C031	10	D001	5	D062	5	E089	11	H061	13	I230	16	J029	6
H001	12	C032	10	D002	5	D063	5	E090	11	H062	13	I231	16	J030	6
H002	12	C033	10	D003	5	D064	7	E091	11	H063	13	I232	16	J031	6
H003	12	C034	10	D004	5	D065	7	E092	11	H064	13	I233	16	J032	6
H010	12	C035	10	D005	5	D066	7	E093	11	H065	13	I234	16	J033	6
H011	12	C036	10	D006	3	D067	7	E094	11	H066	13	I250	16	J034	6
H012	12	C037	10	D007	3	D068	7			H067	13	I251	16	J035	6
H013	12	C038	10	D008	3	D070	7	F000	8	H068	13	I252	16	J036	6
H020	12	C039	10	D009	3	D072	7	F001	8	H069	13	I253	16	J037	6
H021	12	C050	10	D010	3	D074	7	F002	8			I322	16	J038	5
H022	12	C051	10	D012	3	D076	7	F010	8	I000	3	I326	16	J039	5
H023	12	C052	10	D013	5	D077	7			I001	3	I330	16		
H030	12	C053	10	D014	5	D080	3	G080	9	I002	3	I331	16	K000	3
H031	12	C054	10	D015	3	D081	2	G081	9	I003	3	I332	16	K001	3
H032	12	C055	10	D016	3			G082	9	I004	3	I333	16	K002	3
H033	12	C056	10	D017	3	E000	11	G083	9	I005	3	I334	16	K003	3
H040	12	C057	10	D018	5	E001	11	G084	9	I006	3	I350	16	K004	3
H041	12	C058	10	D019	5	E002	11	G085	9	I009	3	I351	16	K005	3
H042	12	C059	10	D020	5	E003	11	G090	9	I010	3	I352	16	K012	3
H043	12	C060	10	D021	5	E004	11	G091	9	I011	3	I353	16	K013	3

TERM	SHEET	TERM	SHEET	TERM	SHEET	TERM	SHEET	TERM	SHEET	TERM	SHEET	TERM	SHEET	TERM	SHEET
K014	3	L014	20	L205	19	L326	21	M112	17	M229	18	N011	19	N201	19
K015	3	L015	20	L206	19	L327	21	M113	17	M230	18	N012	20	N202	19
K016	2	L016	20	L207	19	L328	21	M114	17	M231	18	N013	20	N203	19
K017	2	L017	20	L208	19	L330	21	M115	17	M232	18	N014	20	N204	19
K020	16	L018	20	L209	19			M116	17	M233	18	N015	20	N205	19
K021	16	L019	20	L210	19	M000	16	M117	17	M300	16	N016	20	N206	19
K040	16	L020	20	L211	19	M001	16	M118	17	M301	16	N017	20	N207	19
K041	16	L021	20	L212	20	M002	16	M119	17	M302	16	N018	20	N208	19
K120	16	L022	20	L213	20	M003	16	M120	17	M303	16	N019	20	N209	19
K121	16	L023	20	L214	20	M004	16	M121	17	M304	16	N020	20	N210	19
K140	16	L024	21	L215	20	M005	16	M122	17	M305	16	N021	20	N211	19
K141	16	L025	21	L216	20	M006	16	M123	17	M306	16	N022	20	N212	20
K220	16	L026	21	L217	20	M007	16	M124	18	M307	16	N023	20	N213	20
K221	16	L027	21	L218	20	M008	17	M125	18	M308	17	N024	21	N214	20
K240	16	L028	21	L219	20	M009	17	M126	18	M309	17	N025	21	N215	20
K241	16	L030	21	L220	20	M010	17	M127	18	M310	17	N026	21	N216	20
K320	16	L100	19	L221	20	M011	17	M128	18	M311	17	N027	21	N217	20
K321	16	L101	19	L222	20	M012	17	M129	18	M312	17	N028	21	N218	20
K340	16	L102	19	L223	20	M013	17	M130	18	M313	17	N029	21	N219	20
K341	16	L103	19	L224	21	M014	17	M131	18	M314	17	N030	21	N220	20
K810	4	L104	19	L225	21	M015	17	M132	18	M315	17	N100	19	N221	20
K811	4	L105	19	L226	21	M016	17	M133	18	M316	17	N101	19	N222	20
K812	4	L106	19	L227	21	M017	17	M200	16	M317	17	N102	19	N223	20
K813	4	L107	19	L228	21	M018	17	M201	16	M318	17	N103	19	N224	21
K814	4	L108	19	L230	21	M019	17	M202	16	M319	17	N104	19	N225	21
K815	4	L109	19	L300	19	M020	17	M203	16	M320	17	N105	19	N226	21
K816	4	L110	19	L301	19	M021	17	M204	16	M321	17	N106	19	N227	21
K817	4	L111	19	L302	19	M022	17	M205	16	M322	17	N107	19	N228	21
K900	4	L112	20	L303	19	M023	17	M206	16	M323	17	N108	19	N229	21
K901	4	L113	20	L304	19	M024	18	M207	16	M324	18	N109	19	N230	21
K902	4	L114	20	L305	19	M025	18	M208	17	M325	18	N111	19	N300	19
K903	4	L115	20	L306	19	M026	18	M209	17	M326	18	N112	20	N301	19
K904	4	L116	20	L307	19	M027	18	M210	17	M327	18	N113	20	N302	19
K905	4	L117	20	L308	19	M028	18	M211	17	M328	18	N114	20	N303	19
K906	4	L118	20	L309	19	M029	18	M212	17	M329	18	N115	20	N304	19
K907	4	L119	20	L310	19	M030	18	M213	17	M330	18	N116	20	N305	19
		L120	20	L311	19	M031	18	M214	17	M331	18	N117	20	N306	19
L000	19	L121	20	L312	20	M032	18	M215	17	M332	18	N118	20	N307	19
L001	19	L122	20	L313	20	M033	18	M216	17	M333	18	N119	20	N308	19
L002	19	L123	20	L314	20	M100	16	M217	17			N120	20	N309	19
L003	19	L124	21	L315	20	M101	16	M218	17	N000	19	N121	20	N310	19
L004	19	L125	21	L316	20	M102	16	M219	17	N001	19	N122	20	N311	19
L005	19	L126	21	L317	20	M103	16	M220	17	N002	19	N123	20	N312	20
L006	19	L127	21	L318	20	M104	16	M221	17	N003	19	N124	21	N313	21
L007	19	L128	21	L319	20	M105	16	M222	17	N004	19	N125	21	N314	22
L008	19	L130	21	L320	20	M106	16	M223	17	N005	19	N126	21	N315	23
L009	19	L200	19	L321	20	M107	16	M224	18	N006	19	N127	21	N316	24
L010	19	L201	19	L322	20	M108	17	M225	18	N007	19	N128	21	N317	20
L011	19	L202	19	L323	20	M109	17	M226	18	N008	19	N129	21	N318	20
L012	20	L203	19	L324	21	M110	17	M227	18	N009	19	N130	21	N319	20
L013	20	L204	19	L325	21	M111	17	M228	18	N010	19	N200	19	N320	20

TERM	SHEET	TERM	SHEET	TERM	SHEET	TERM	SHEET		
X009	13	Y022	11	Y902	4	Z050	11		
X010	13	Y023	11	Y903	4	Z051	11		
X011	13	Y024	11	Y904	4	Z052	11		
X012	13	Y025	11	Y905	4	Z053	11		
X013	13	Y026	11	Y906	4	Z054	11		
X014	13	Y028	11	Y920	4	Z055	11		
X015	13	Y029	11			Z056	11		
X016	13	Y030	11	Z004	6	Z057	11		
X017	13	Y031	3	Z005	6	Z058	11		
X018	13	Y032	8	Z006	8	Z059	11		
X019	13	Y033	5	Z007	8	Z060	11		
X020	13	Y034	11	Z008	8	Z061	11		
X021	13	Y035	11	Z009	8	Z062	11		
X022	13	Y036	11	Z010	8	Z063	11		
X023	13	Y037	8	Z011	8	Z064	11		
X024	13	Y038	11	Z012	8	Z065	11		
X025	13	Y039	8	Z013	8	Z068	8	Z066	11
X026	13	Y040	11	Z014	8	Z069	8	Z067	11
X027	13	Y041	7	Z015	8	Z070	8		
X028	13	Y042	12	Z016	8	Z071	8		
X029	13	Y044	11	Z017	8	Z072	11		
X030	13	Y045	11	Z020	8	Z073	11		
X031	13	Y046	7	Z021	8	Z074	11		
X032	13	Y047	3	Z022	8	Z075	11		
X033	13	Y050	8	Z023	8	Z076	11		
X034	13	Y051	8	Z024	8	Z077	11		
X035	13	Y052	8	Z025	8	Z078	11		
X036	13	Y053	8	Z026	8	Z079	11		
X037	13	Y054	8	Z027	8	Z080	8		
		Y055	8	Z028	8	Z081	8		
Y000	3	Y056	8	Z029	8	Z082	8		
Y001	5	Y057	8	Z030	12	Z083	8		
Y002	3	Y058	8	Z031	12	Z084	8		
Y003	12	Y059	8	Z032	12	Z085	8		
Y004	8	Y060	11	Z033	12	Z086	11		
Y006	3	Y061	11	Z034	12	Z087	11		
Y007	8	Y062	5	Z035	12	Z088	11		
Y008	8	Y063	5	Z036	12	Z089	11		
Y009	8	Y064	5	Z037	12	Z090	11		
Y010	11	Y070	11	Z038	12	Z091	11		
Y011	8	Y071	7	Z039	12	Z092	12		
Y012	11	Y072	11	Z040	11	Z093	12		
Y013	8	Y080	14	Z041	11	Z094	12		
Y014	8	Y084	14	Z042	11	Z095	12		
Y015	2	Y800	4	Z043	11	Z096	11		
Y016	2	Y801	4	Z044	11	Z097	11		
Y017	2	Y802	4	Z045	11				
Y018	11	Y804	4	Z046	11				
Y019	11	Y810	4	Z047	11				
Y020	11	Y900	4	Z048	11				
Y021	11	Y901	4	Z049	11				

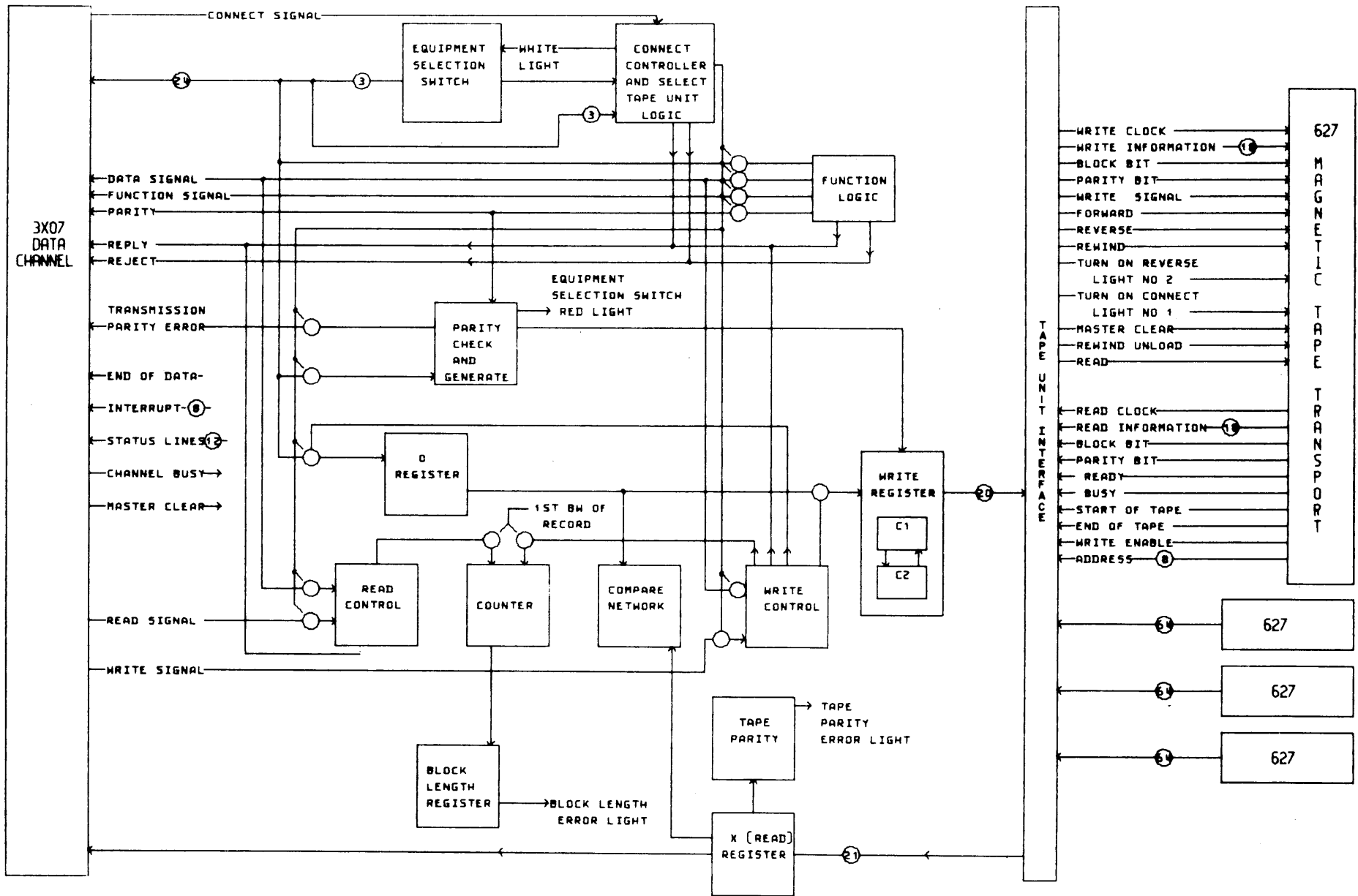

TERM	LOC'N	SHEET	DESCRIPTION	TERM	LOC'N	SHEET	DESCRIPTION
D001	C51B	5		H054	I79A	13	
D025	E81B	5		H055	I79B	13	
D034	E60B	8		H056	I79C	13	
D038	I63B	5		H057	I79D	13	
E091	I65A	11		H058	I80A	13	
E092	I65B	11		H059	I80B	13	
E093	I84A	11		H060	I80C	13	
E094	I84B	11		H061	I80D	13	
H050	I78A	13		H062	I81A	13	
H051	I78B	13		H063	I81B	13	
H052	I78C	13		H064	I81C	13	
H053	I78D	13		H065	I81D	13	

TERM	LOC'N	SHEET	DESCRIPTION	TERM	LOC'N	SHEET	DESCRIPTION
H066	I82A	13		P083	J85C	14	
H067	I82B	13		P088	I83C	13	
H068	I82C	13		P090	J87C	14	
I017	B55A	3		P091	J87D	14	
I019	B55B	3		W071	E67A	8	
J035	C65A	6		Z005	B61C	6	
K001	B56C	3		Z035	G83A	12	
K005	B51C	3		Z039	H75C	12	
K013	B69A	3		Z073	C85C	11	
K015	B71A	3		Z079	C84C	11	
K017	J51C	2		Z097	C90C	11	

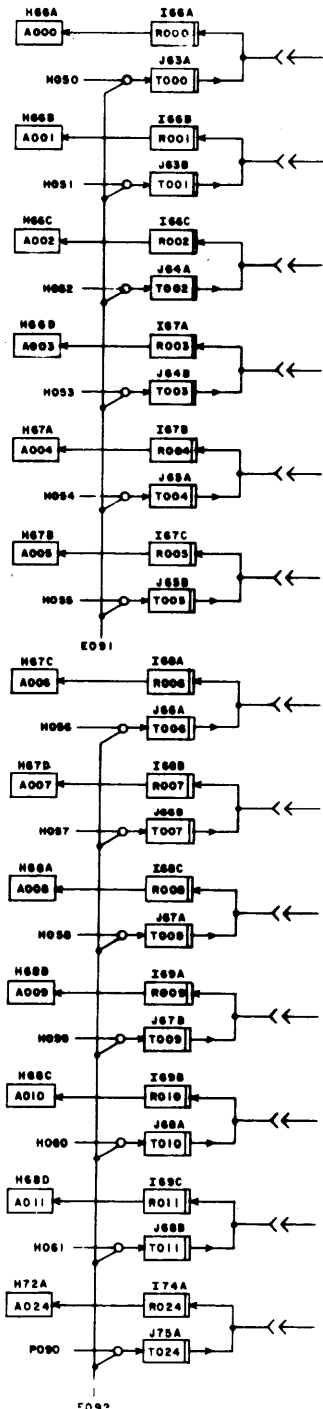

DATA 1

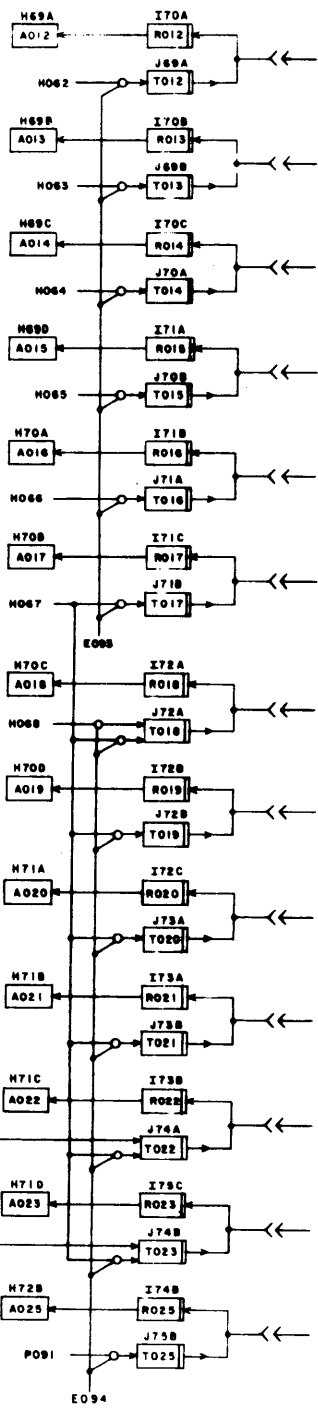

DATA 2

STATUS LINES

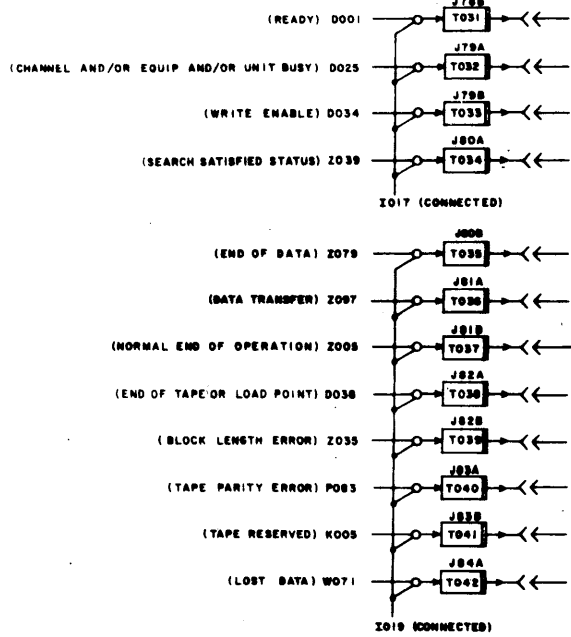

CONTROL LINES

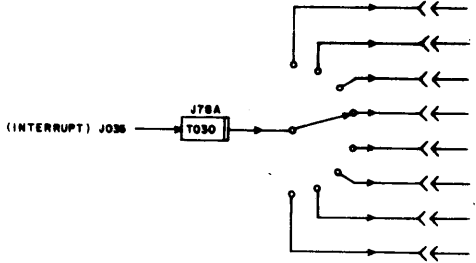
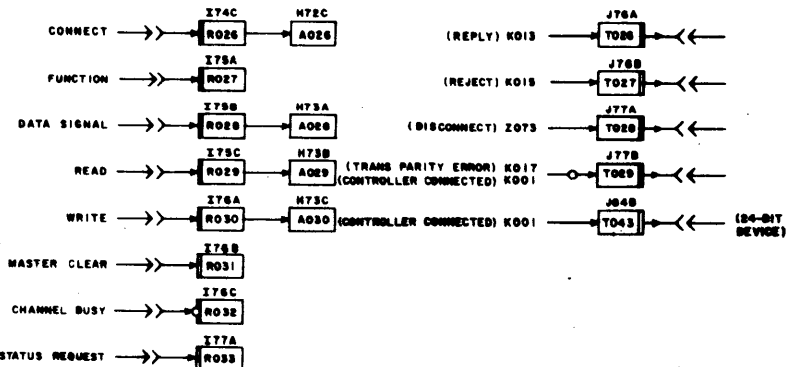

TERM	LOC'N	SHEET	DESCRIPTION	TERM	LOC'N	SHEET	DESCRIPTION
A000	H66A	1		A015	H69D	1	
A001	H66B	1		A016	H70A	1	
A002	H66C	1		A017	H70B	1	
A003	H66D	1		A018	H70C	1	
A004	H67A	1		A019	H70D	1	
A005	H67B	1		A020	H71A	1	
A006	H67C	1		A021	H71B	1	
A007	H67D	1		A022	H71C	1	
A008	H68A	1		A023	H71D	1	
A009	H68B	1		A024	H72A	1	
A010	H68C	1		A025	H72B	1	
A011	H68D	1		A026	H72C	1	
A012	H69A	1		D021	C91A	5	
A013	H69B	1		K000	B56A	3	
A014	H69C	1		R000	I66A	1	

TERM	LOC'N	SHEET	DESCRIPTION	TERM	LOC'N	SHEET	DESCRIPTION
R001	I66B	1		R015	I71A	1	
R002	I66C	1		R016	I71B	1	
R003	I67A	1		R017	I71C	1	
R004	I67B	1		R018	I72A	1	
R005	I67C	1		R019	I72B	1	
R006	I68A	1		R020	I72C	1	
R007	I68B	1		R021	I73A	1	
R008	I68C	1		R022	I73B	1	
R009	I69A	1		R023	I73C	1	
R010	I69B	1		R024	I74A	1	
R011	I69C	1		R025	I74B	1	
R012	I70A	1		R026	I74C	1	
R013	I70B	1		R027	I75A	1	
R014	I70C	1		Y011	D68A	8	

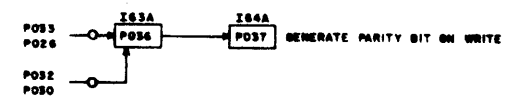
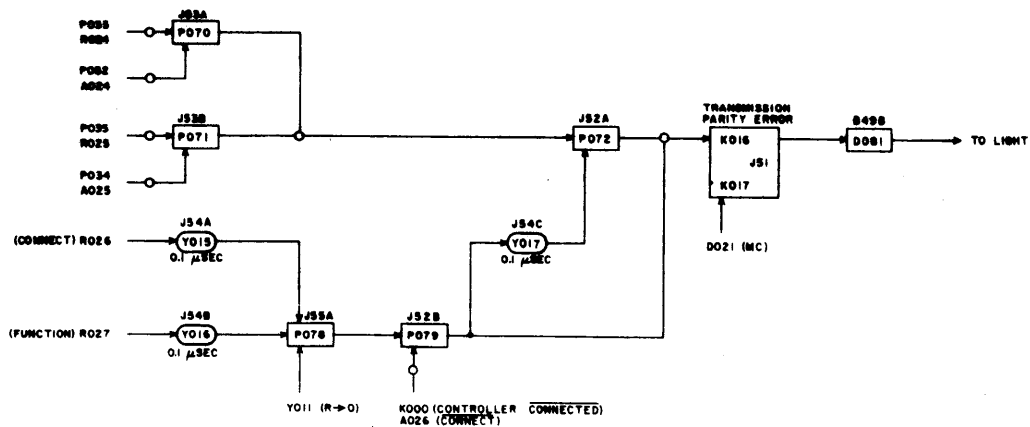
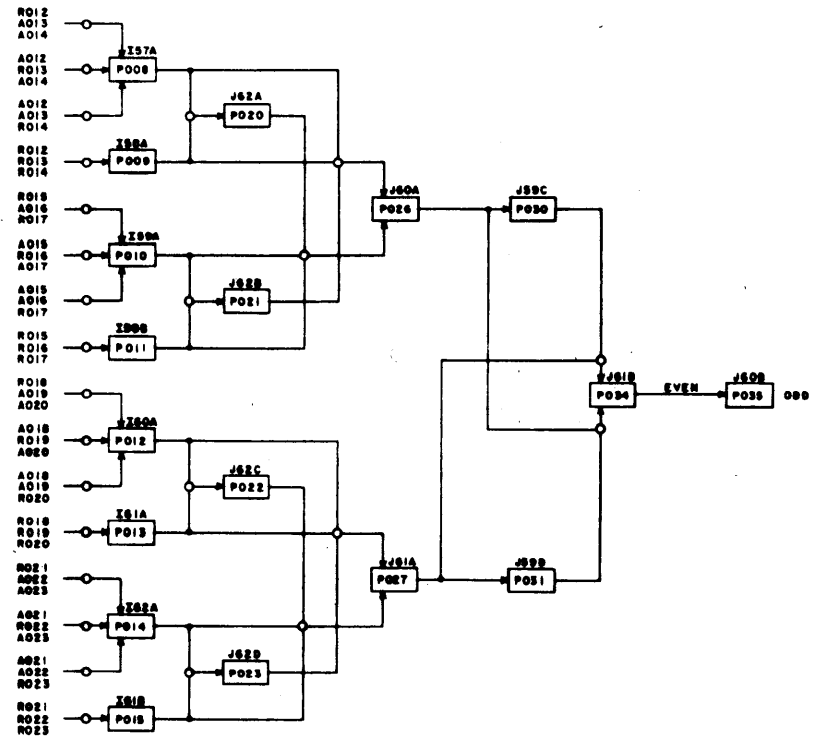
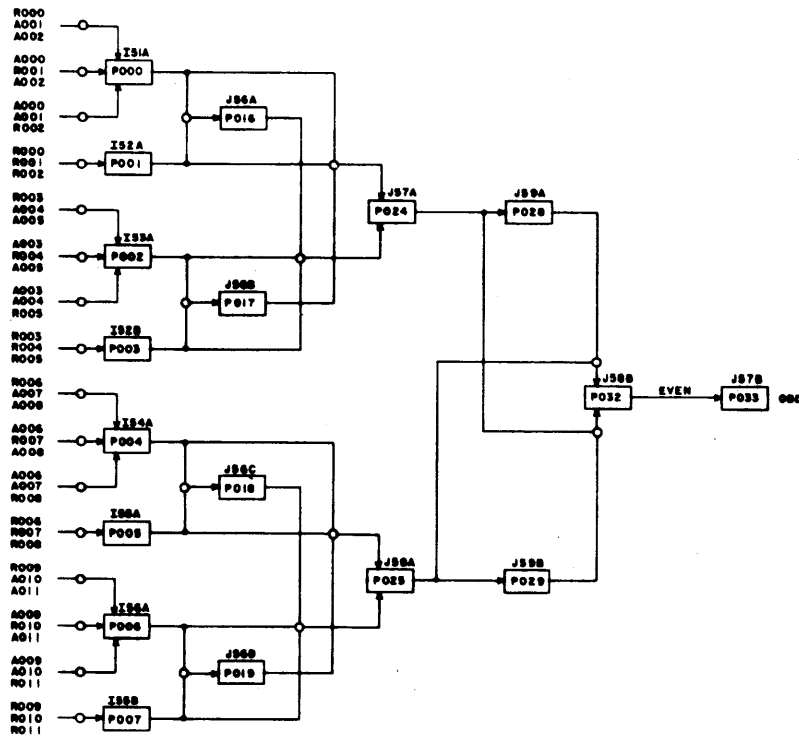

TERM	LOC'N	SHEET	DESCRIPTION	TERM	LOC'N	SHEET	DESCRIPTION
A009	H68B	1		I020	D77A	5	
A010	H68C	1		J001	B84C	5	
A011	H68D	1		J003	B85C	5	
D003	C52B	5		J005	B86C	5	
D005	D77B	5		J007	B87C	5	
D014	D87B	5		J010	B90B	5	
D019	C91A	5		K016	J51A	2	
D031	C54A	8		K017	J51C	2	
I807	K65A	4		K813	K77C	4	
I811	K74A	4		K815	K75C	4	

TERM	LOC'N	SHEET	DESCRIPTION	TERM	LOC'N	SHEET	DESCRIPTION
R009	I69A	1		U010	C22B	16	
R010	I69B	1		U110	F22B	16	
R011	I69C	1		U210	I22B	16	
R026	I74C	1		U310	L22B	16	
R028	I75B	1		Y011	D68A	8	
S030	G75A	5		Z013	D67C	8	
S031	G76A	5		Z025	D58C	8	
S033	G75B	5		Z071	E68A	8	
S052	H74A	5		Z075	D90A	11	

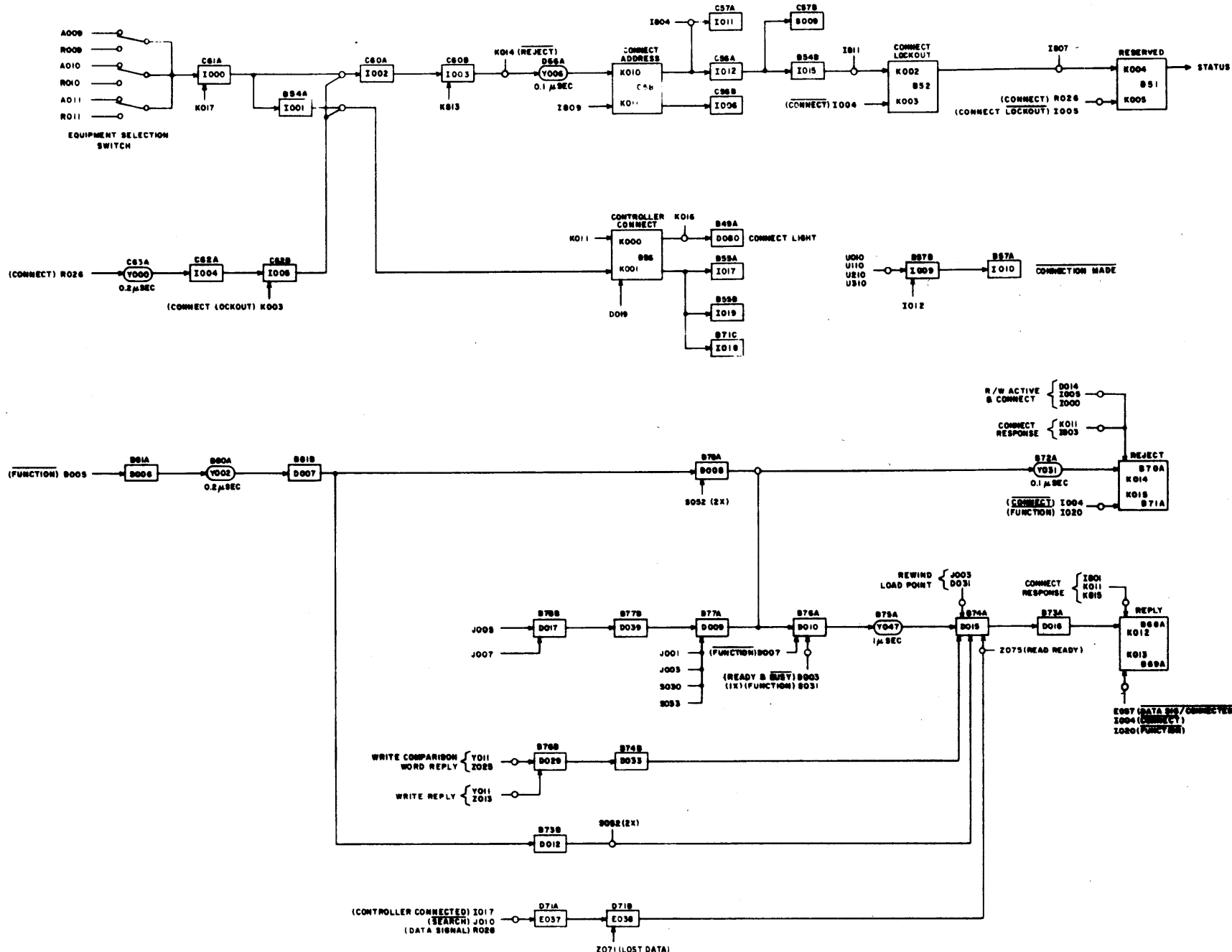

TERM	LOC'N	SHEET	DESCRIPTION	TERM	LOC'N	SHEET	DESCRIPTION
I010	B57A	3		U120	F21B	16	
U020	C21B	16		U220	I21B	16	

TERM	LOC'N	SHEET	DESCRIPTION	TERM	LOC'N	SHEET	DESCRIPTION
U320	L21B	16		W910	K60A	4	

CONNECT CHAIN

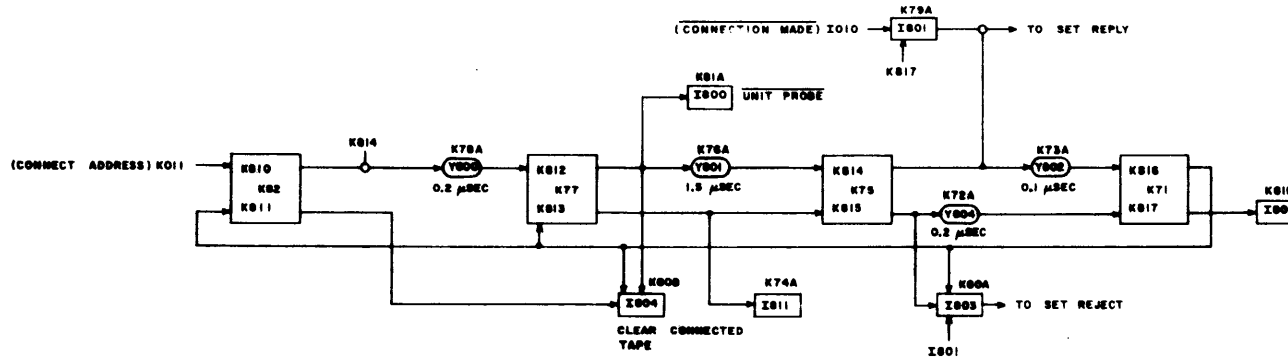

WRITE OSCILLATOR

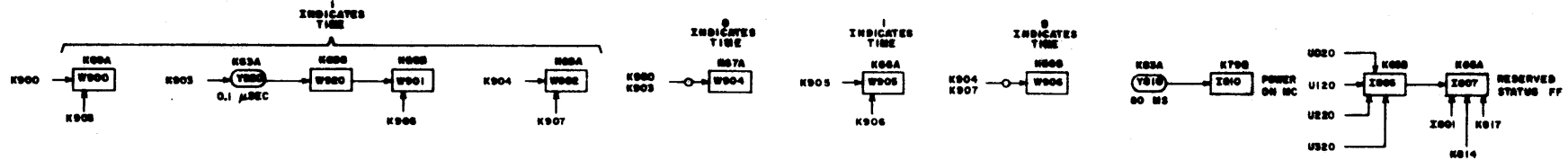
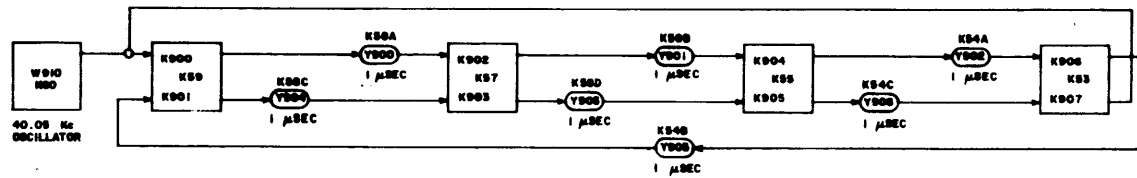

CONTROL DATA CORPORATION COMPUTER DIVISION	TITLE CONNECT CHAIN, WRITE OSCILLATOR, POWER ON MASTER CLEAR	PRODUCT SP OPTION 60026		
		SIZE C	DRAWING NO. 38705100	REV
		SHEET 4	PAGE 4-17	

TERM	LOC'N	SHEET	DESCRIPTION	TERM	LOC'N	SHEET	DESCRIPTION
A000	H66A	1		J025	D70B	6	
A001	H66B	1		K013	B69A	3	
A002	H66C	1		K015	B71A	3	
A003	H66D	1		K017	J51C	2	
A004	H67A	1		R000	I66A	1	
D007	B81B	3		R001	I66B	1	
I017	B55A	3		R002	I66C	1	
I018	B71C	3		R003	I67A	1	
I810	K79B	4		R004	I67B	1	

TERM	LOC'N	SHEET	DESCRIPTION	TERM	LOC'N	SHEET	DESCRIPTION
R005	I67C	1		Z021	D56A	8	
R027	I75A	1		Z023	D51C	8	
R031	I76B	1		Z043	D85C	11	
R032	I76C	1		Z044	D82A	11	
U030	C42A	17		Z045	D82C	11	
U032	C41A	17		Z049	E77C	11	
U078	J44A	18		Z065	E75C	11	
Z006	C55A	8		Z070	E69A	8	

TERM	LOC'N	SHEET	DESCRIPTION	TERM	LOC'N	SHEET	DESCRIPTION
D003	C52B	5		E044	D92A	11	
D019	C91A	5		E089	D74A	11	
D020	C91B	5		F003	D59B	8	
D023	D87A	5		J015	B91C	5	
D030	C69B	5		R032	I76C	1	
D031	C54A	8		S020	G71A	5	
D032	C54B	5		S021	G71B	5	
D064	C80A	7					

TERM	LOC'N	SHEET	DESCRIPTION	TERM	LOC'N	SHEET	DESCRIPTION
S022	G72A	5		S052	H74A	5	
S023	G72B	5		T029	J77B	1	
S024	G73A	5		Z033	F90C	12	
S025	G73B	5		Z035	G83A	12	
S026	G74A	5		Z071	E68A	8	
S027	G74B	5		Z073	C85C	11	
S032	G76B	5		Z079	C84C	11	
				Z034	G84A	12	

TERM	LOC'N	SHEET	DESCRIPTION	TERM	LOC'N	SHEET	DESCRIPTION
D003	C52B	5		J001	B84C	5	
D013	D76B	5		J003	B85C	5	
D015	B74A	3		J005	B86C	5	
D018	C92A	5		J014	B91A	5	
D021	C91C	5		J015	B91C	5	
D022	C91D	5		J018	B89A	5	
D063	B60A	5		J019	B89C	5	

TERM	LOC'N	SHEET	DESCRIPTION	TERM	LOC'N	SHEET	DESCRIPTION
J026	B88A	5		Z043	D85C	11	
J027	B88C	5		Z044	D82A	11	
Z009	D64C	8		Z045	D82C	11	
Z021	D56A	8		Z047	E80C	11	
Z023	D51C	8		Z065	E75C	11	
Z042	D85A	11		Z079	C84C	11	

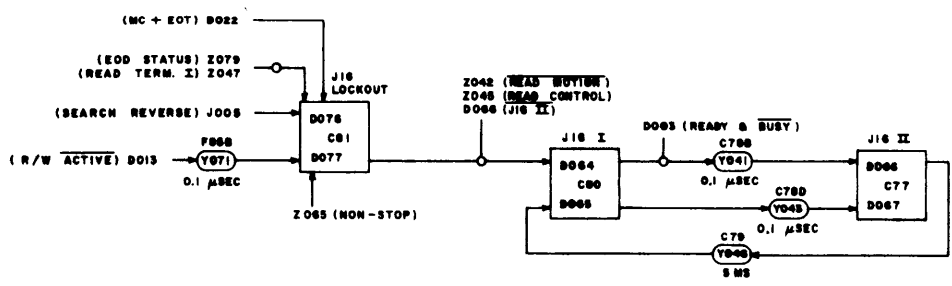
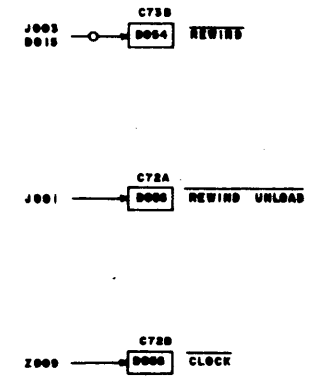
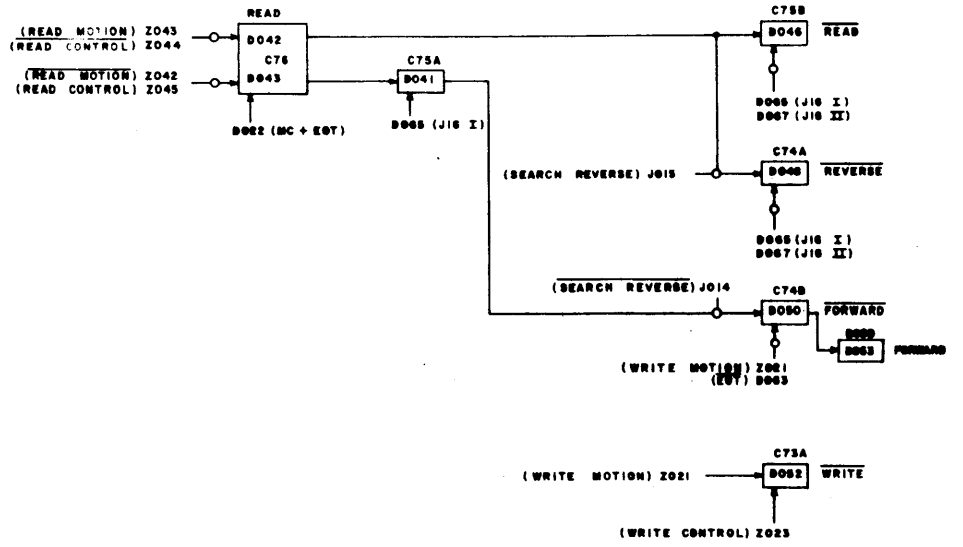
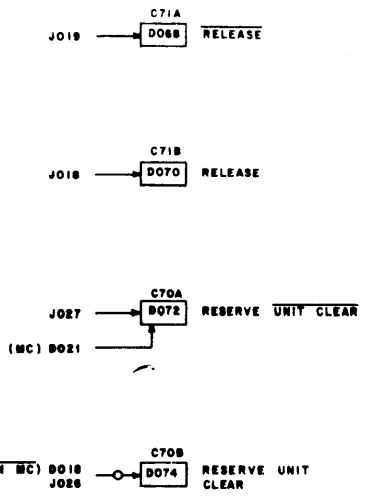

TERM	LOC'N	SHEET	DESCRIPTION	TERM	LOC'N	SHEET	DESCRIPTION
A016	H70A	1		D024	E81A	5	
A017	H70B	1		E000	F84B	11	
A018	H70C	1		I005	C62B	3	
A028	H73A	1		I017	B55A	3	
A030	H73C	1		I018	B71C	3	
C087	H60B	10		I021	D76A	5	
D002	C52A	5		I810	K79B	4	
D013	D76B	5		J009	B90A	5	
D020	C91B	5		J010	B90B	5	
D021	C91C	5		J025	D70B	6	

TERM	LOC'N	SHEET	DESCRIPTION	TERM	LOC'N	SHEET	DESCRIPTION
J038	B83A	5		W900	K69A	4	
J039	B83C	5		W901	K69B	4	
K900	K59A	4		W902	K68A	4	
K906	K53A	4		W905	K66A	4	
R016	I71B	1		W906	K66B	4	
R018	I72A	1		Z043	D85C	11	
R020	I72C	1		Z075	D90A	11	
R028	I75B	1		Z077	C83C	11	
U076	I39A	18		Z087	C89A	11	
U080	J43A	18					

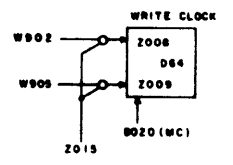
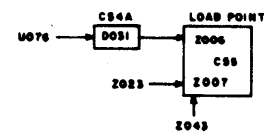
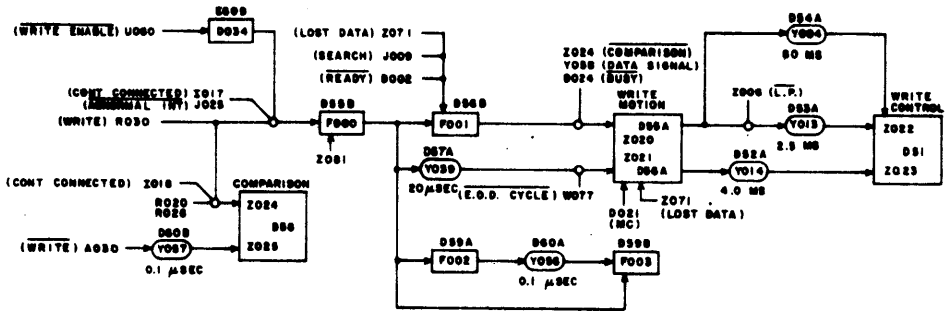
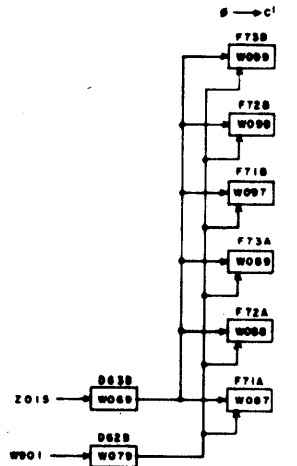
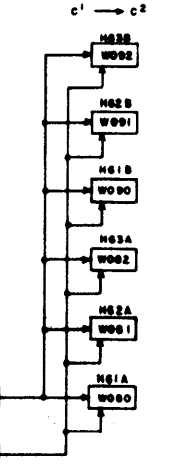
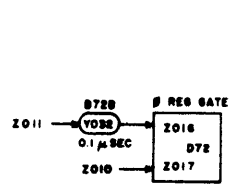
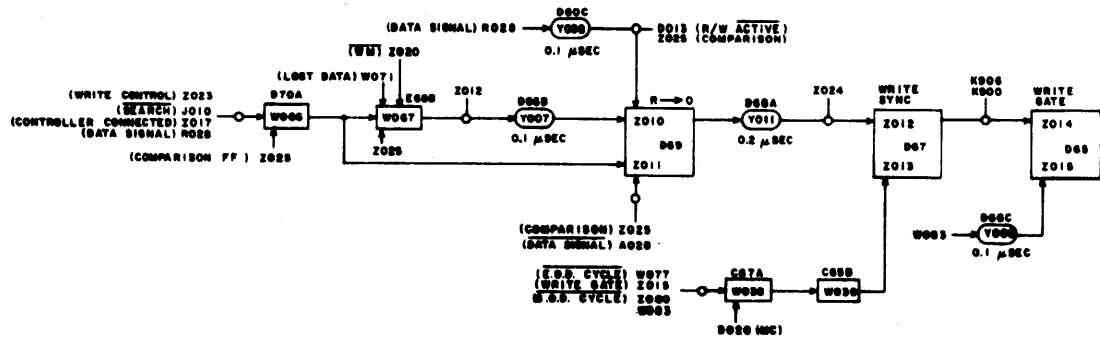

S.O.D.

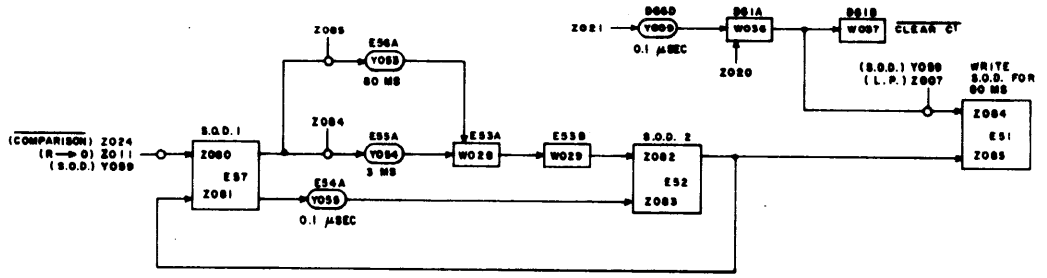

LOST DATA

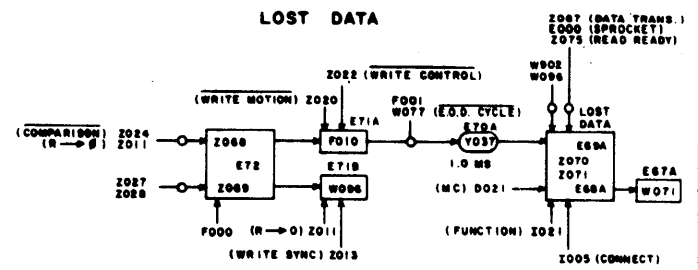

E.O.D.

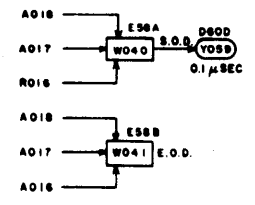
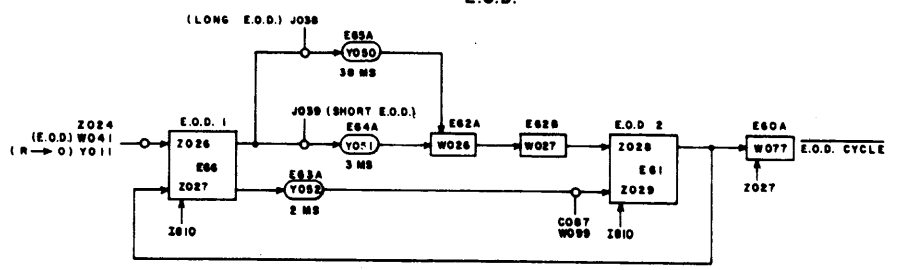

 CONTROL DATA CORPORATION COMPUTER DIVISION	TITLE	PRODUCT
	WRITE CONTROL	SP. OPTION 60026
	SIZE	DESIGN NO.
C	38705100	2
8	4-25	

TERM	LOC'N	SHEET	DESCRIPTION	TERM	LOC'N	SHEET	DESCRIPTION
A000	H66A	1		A014	H69C	1	
A001	H66B	1		A015	H69D	1	
A002	H66C	1		A016	H70A	1	
A003	H66D	1		A017	H70B	1	
A004	H67A	1		A018	H70C	1	
A005	H67B	1		E038	D71B	3	
A006	H67C	1		P036	I63A	2	
A007	H67D	1		P037	I64A	2	
A008	H68A	1		P080	J86A	14	
A009	H68B	1		R000	I66A	1	
A010	H68C	1		R001	I66B	1	
A011	H68D	1		R002	I66C	1	
A012	H69A	1		R003	I67A	1	
A013	H69B	1					

TERM	LOC'N	SHEET	DESCRIPTION	TERM	LOC'N	SHEET	DESCRIPTION
R004	I67B	1		R017	I71C	1	
R005	I67C	1		R018	I72A	1	
R006	I68A	1		W032	H81A	12	
R007	I68B	1		X032	H93A	13	
R008	I68C	1		X033	H93B	13	
R009	I69A	1		X034	H93C	13	
R010	I69B	1		X035	H93D	13	
R011	I69C	1		X036	H94A	13	
R012	I70A	1		X037	H94B	13	
R013	I70B	1		Z011	D69C	8	
R014	I70C	1		Z016	D72A	8	
R015	I71A	1		Z075	D90A	11	
R016	I71B	1		Z087	C89A	11	

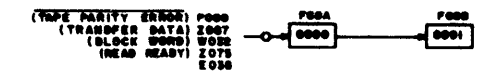
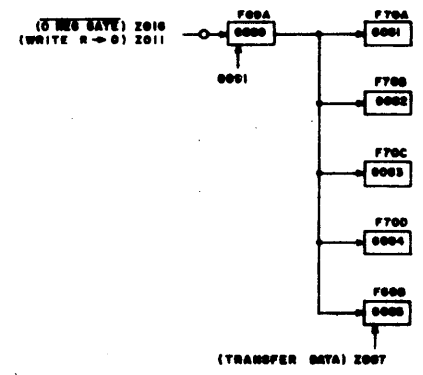
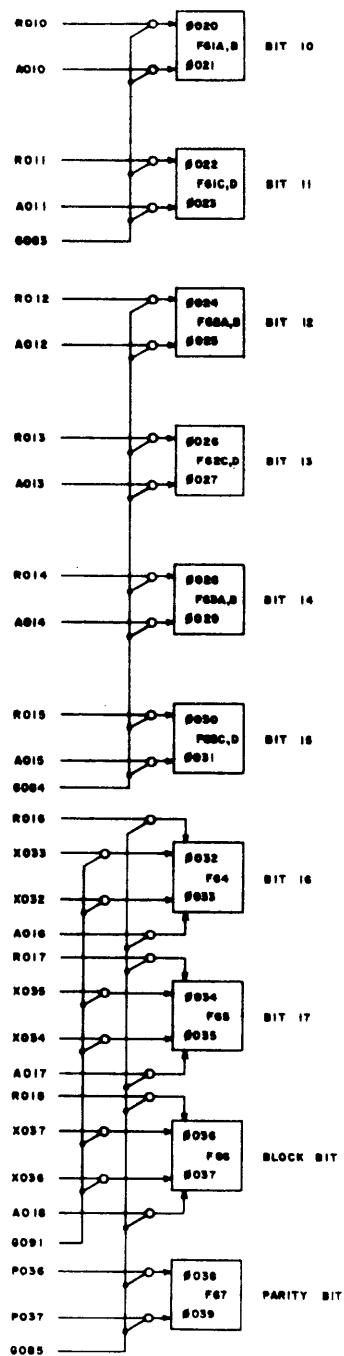
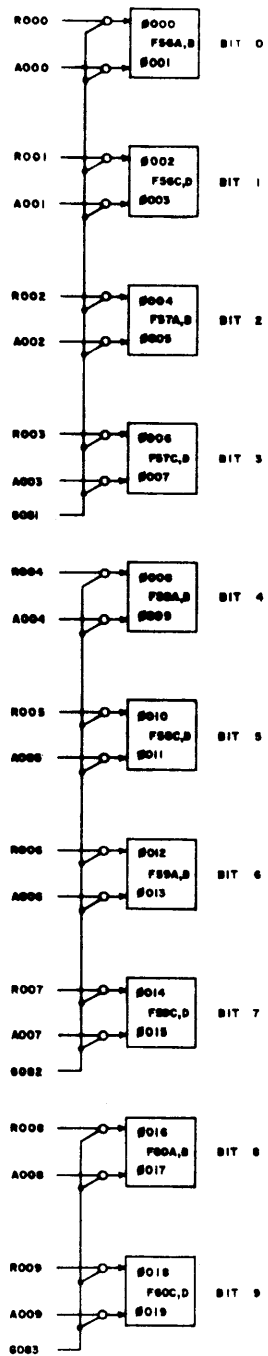

TERM	LOC'N	SHEET	DESCRIPTION	TERM	LOC'N	SHEET	DESCRIPTION
O001	F56B	9		O019	F60D	9	
O003	F56D	9		O021	F61B	9	
O005	F57B	9		O023	F61D	9	
O007	F57D	9		O025	F62B	9	
O009	F58B	9		O027	F62D	9	
O011	F58D	9		O029	F63B	9	
O013	F59B	9		O031	F63D	9	
O015	F59D	9		O033	F64C	9	
O017	F60B	9					

TERM	LOC'N	SHEET	DESCRIPTION	TERM	LOC'N	SHEET	DESCRIPTION
O035	F65C	9		W088	F72A	8	
O037	F66C	9		W089	F73A	8	
O039	F67C	9		W090	H61B	8	
W037	D61B	8		W091	H62B	8	
W080	H61A	8		W092	H63B	8	
W081	H62A	8		W097	F71B	8	
W082	H63A	8		W098	F72B	8	
W087	F71A	8		W099	F73B	8	

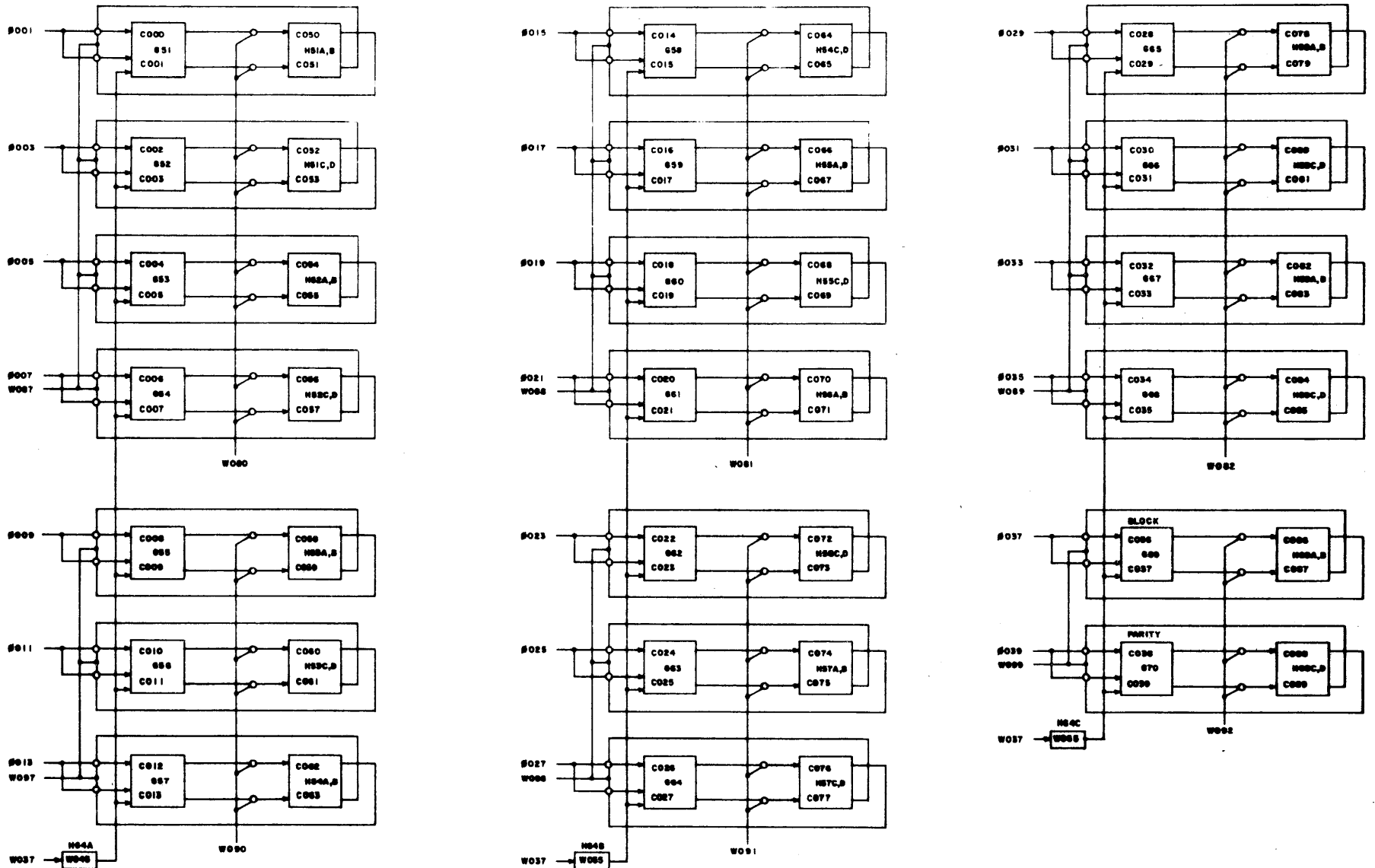

CO01	CO03	CO05	CO07	CO09	CO11	CO13	CO15	CO17	CO19	CO21	CO23	CO25	CO27	CO29	CO31	CO33	CO35	CO37	CO39
WO00	WO01	WO02	WO03	WO04	WO05	WO06	WO07	WO08	WO09	WO10	WO11	WO12	WO13	WO14	WO15	WO16	WO17	WO18	WO19
FS1A	FS1B	FS1C	FS1D	FS2A	FS2B	FS2C	FS2D	FS3A	FS3B	FS3C	FS3D	FS4A	FS4B	FS4C	FS4D	FS5A	FS5B	FS5C	FS5D

TO TAPE UNITS

 CONTROL DATA CORPORATION COMPUTER DIVISION	TITLE	PROPERTY
	WRITE REGISTERS	SP. OPTION 6006
		REV
		C 38706100
		10 4-29

TERM	LOC'N	SHEET	DESCRIPTION	TERM	LOC'N	SHEET	DESCRIPTION
A030	H73C	1		D030	C69B	5	
D002	C52A	5		D032	C54B	5	
D019	C91A	5		D053	B60D	7	
D020	C91B	5		D062	C92B	5	
D021	C91C	5		I017	B55A	3	
D022	C91D	5		I018	B71C	3	
D024	E81A	5		J010	B90B	5	
D027	C66B	6		J025	D70B	6	

TERM	LOC'N	SHEET	DESCRIPTION	TERM	LOC'N	SHEET	DESCRIPTION
J033	B65C	6		W060	H78A	12	
K013	B69A	3		W061	H78B	12	
P089	I83D	13		Y064	C93A	5	
Q010	F83B	12		Z022	D51A	8	
R029	I75C	1		Z023	D51C	8	
U034	C40A	17		Z033	F90C	12	
W031	H82B	12		Z035	G83A	12	
W032	H81A	12					

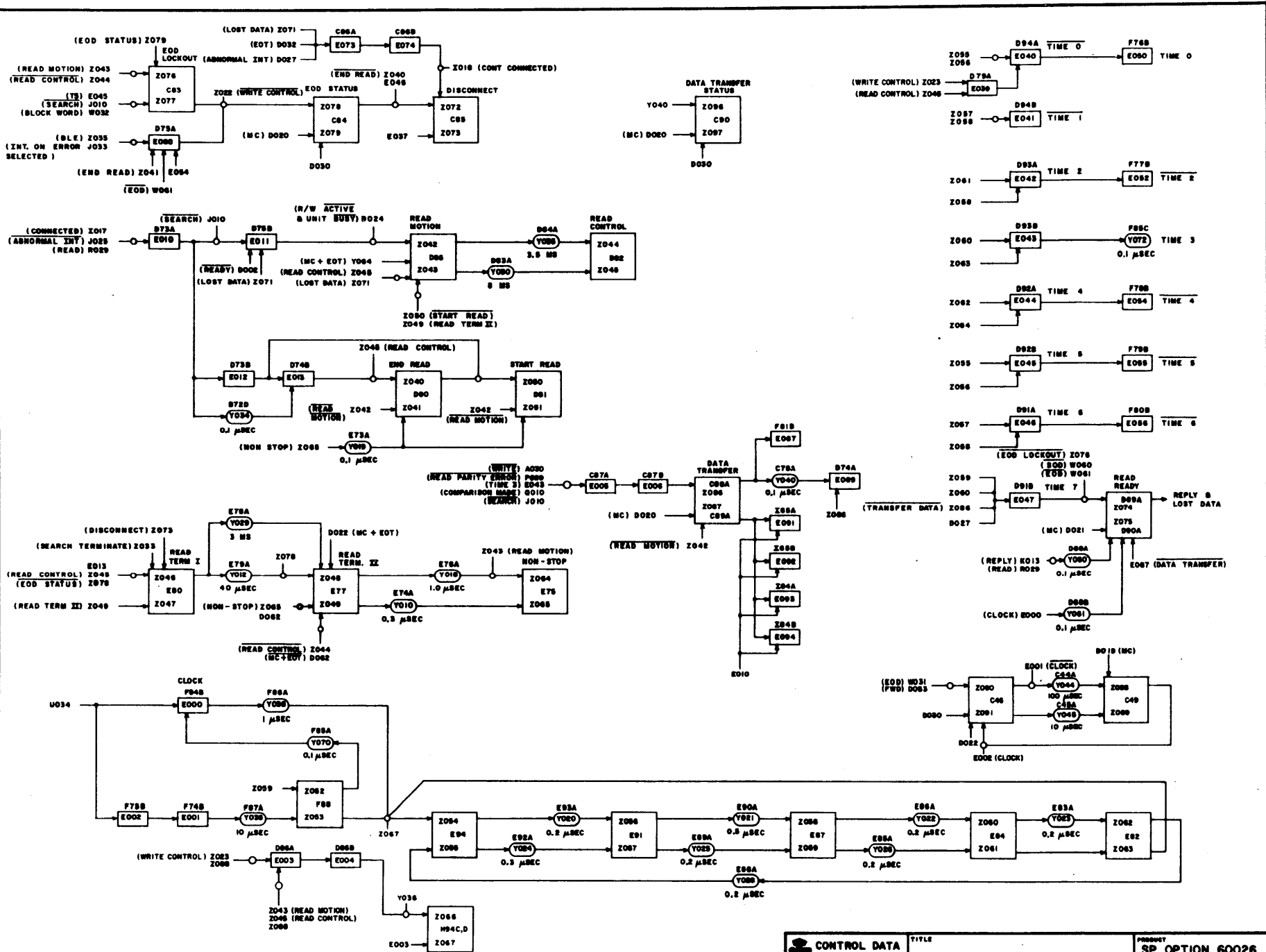

CONTROL DATA CORPORATION
COMPUTER DIVISION

TITLE
READ CONTROL

PRODUCT
SP. OPTION 60026

SIZE DRAWING NO. REV
C 38705100 B

SHEET PAGE
11 4-31

TERM	LOC'N	SHEET	DESCRIPTION	TERM	LOC'N	SHEET	DESCRIPTION
D019	C91A	5		O008	F58A	9	
D020	C91B	5		O009	F58B	9	
D021	C91C	5		O010	F58C	9	
D030	C69B	5		O011	F58D	9	
E042	D93A	11		O012	F59A	9	
E043	D93B	11		O013	F59B	9	
E044	D92A	11		O014	F59C	9	
E046	D91A	11		O015	F59D	9	
E054	F78B	11		O016	F60A	9	
E055	F79B	11		O017	F60B	9	
J005	B86C	5		O018	F60C	9	
J007	B87C	5		O019	F60D	9	
J009	B90A	5		O020	F61A	9	
J010	B90B	5		O021	F61B	9	
J014	B91A	5		O022	F61C	9	
J015	B91C	5		O023	F61D	9	
J016	B91A	5		O024	F62A	9	
O000	F56A	9		O025	F62B	9	
O001	F56B	9		O026	F62C	9	
O002	F56C	9		O027	F62D	9	
O003	F56D	9		O028	F63A	9	
O004	F57A	9		O029	F63B	9	
O005	F57B	9		O030	F63C	9	
O006	F57C	9		O031	F63D	9	
O007	F57D	9					

TERM	LOC'N	SHEET	DESCRIPTION	TERM	LOC'N	SHEET	DESCRIPTION
O032	F64A	9		X017	H89B	13	
O033	F64C	9		X018	H89C	13	
O034	F65A	9		X019	H89D	13	
O035	F65C	9		X020	H90A	13	
O036	F66A	9		X021	H90B	13	
O037	F66C	9		X022	H90C	13	
R030	I76A	1		X023	H90D	13	
X000	H85A	13		X024	H91A	13	
X001	H85B	13		X025	H91B	13	
X002	H85C	13		X026	H91C	13	
X003	H85D	13		X027	H91D	13	
X004	H86A	13		X028	H92A	13	
X005	H86B	13		X029	H92B	13	
X006	H86C	13		X030	H92C	13	
X007	H86D	13		X031	H92D	13	
X008	H87A	13		X032	H93A	13	
X009	H87B	13		X033	H93B	13	
X010	H87C	13		X034	H93C	13	
X011	H87D	13		X035	H93D	13	
X012	H88A	13		X036	H94A	13	
X013	H88B	13		X037	H94B	13	
X014	H88C	13		Y072	F85C	11	
X015	H88D	13		Z020	D55A	8	
X016	H89A	13		Z086	C88A	11	

PO81 J86B 14

TERM	LOC'N	SHEET	DESCRIPTION	TERM	LOC'N	SHEET	DESCRIPTION
E040	D94A	11		U042	D40A	17	
E041	D94B	11		U044	D39A	17	
P080	J86A	14		U046	E42A	17	
U036	C39A	17		U048	E41A	17	
U038	D42A	17		U050	E40A	17	
U040	D41A	17		U052	E39A	17	

TERM	LOC'N	SHEET	DESCRIPTION	TERM	LOC'N	SHEET	DESCRIPTION
U054	F43A	17		U066	H42A	18	
U056	F42A	17		U068	H41A	18	
U058	F41A	17		U070	I42A	18	
U060	G44A	17		U072	I41A	18	
U062	G43A	18		U074	I40A	18	
U064	H43A	18		Z088	C49A	11	

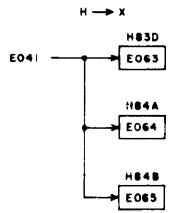
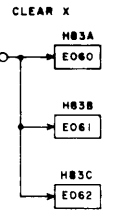
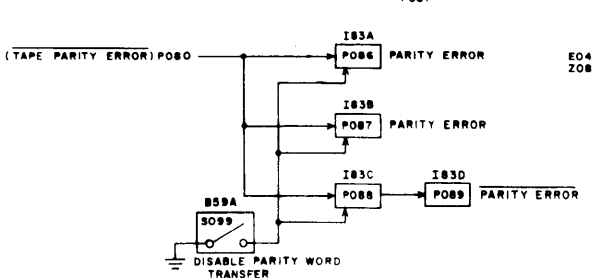
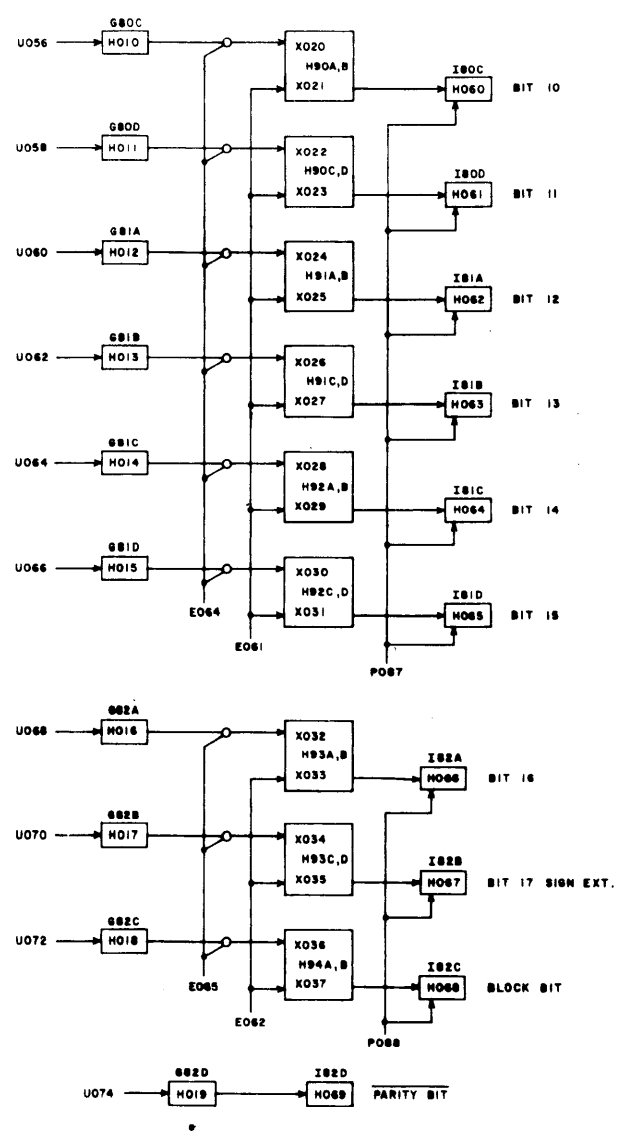
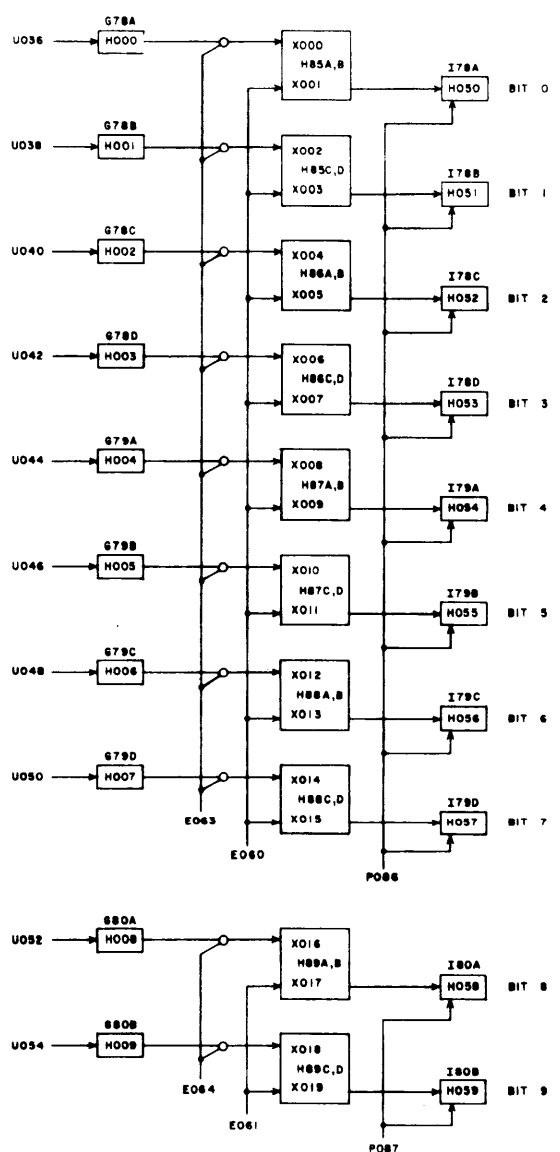

TERM	LOC'N	SHEET	DESCRIPTION	TERM	LOC'N	SHEET	DESCRIPTION
D021	C91C	5		X002	H85C	13	
D030	C69B	5		X003	H85D	13	
E042	D93A	11		X004	H86A	13	
E050	F76B	11		X005	H86B	13	
E054	F78B	11		X006	H86C	13	
H019	G82D	13		X007	H86D	13	
P089	I83D	13		X008	H87A	13	
R033	I77A	1		X009	H87B	13	
W047	C53B	12		X010	H87C	13	
W060	H78A	12		X011	H87D	13	
W061	H78B	12		X012	H88A	13	
X000	H85A	13		X013	H88B	13	
X001	H85B	13		X014	H88C	13	

TERM	LOC'N	SHEET	DESCRIPTION	TERM	LOC'N	SHEET	DESCRIPTION
X015	H88D	13		X027	H91D	13	
X016	H89A	13		X028	H92A	13	
X017	H89B	13		X029	H92B	13	
X018	H89C	13		X030	H92C	13	
X019	H89D	13		X031	H92D	13	
X020	H90A	13		X032	H93A	13	
X021	H90B	13		X033	H93B	13	
X022	H90C	13		X034	H93C	13	
X023	H90D	13		X035	H93D	13	
X024	H91A	13		X036	H94A	13	
X025	H91B	13		X037	H94B	13	
X026	H91C	13		Z077	C83C	11	

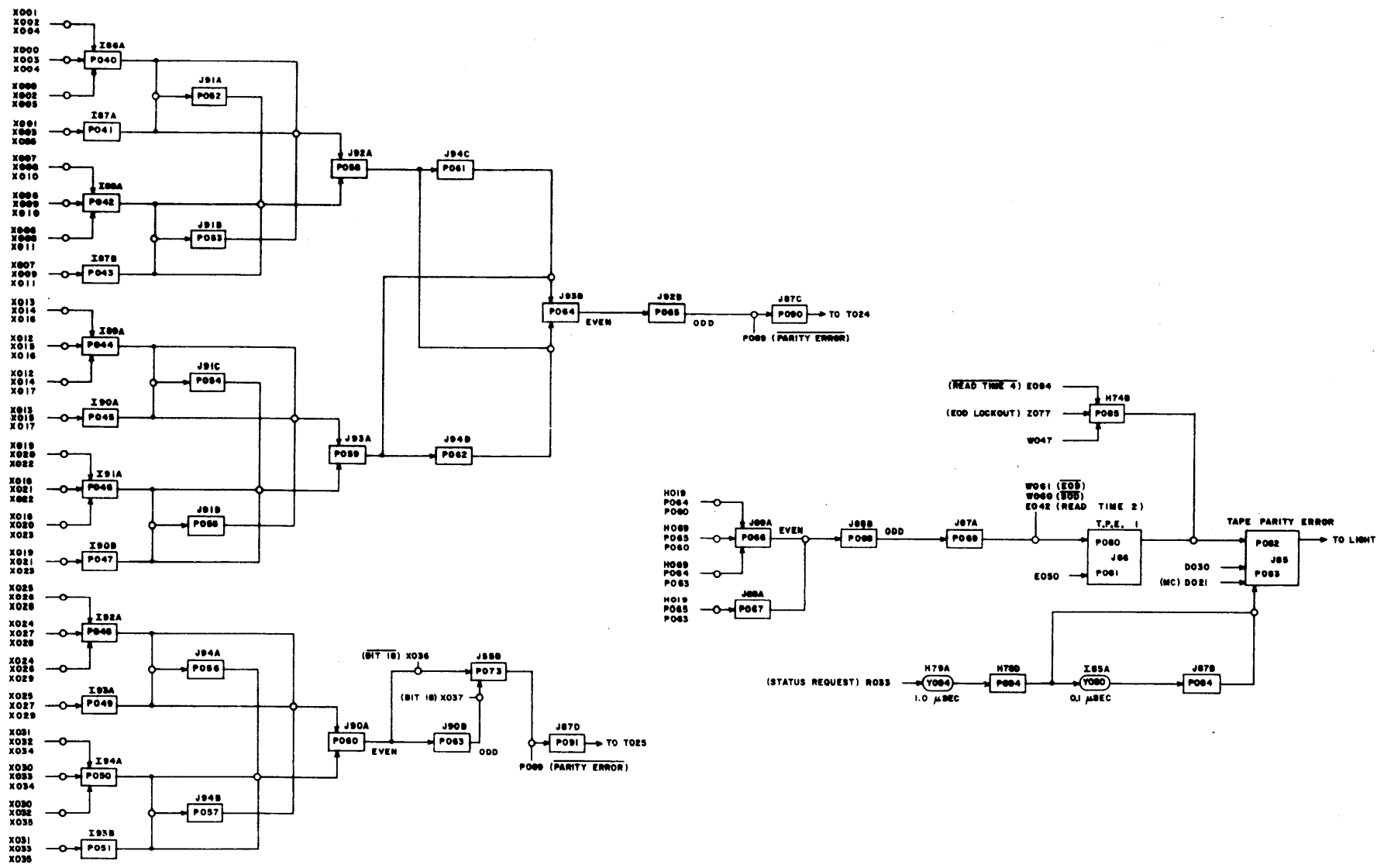

WRITE SEQUENCE

The following sequence of events indicates the primary control signals which are active during a write operation. Write timing is illustrated on page 4-39.

<u>Step</u>	<u>Event</u>	<u>Description</u>
1a.	Write Signal	The Write signal places the connected tape unit in write status and enables write (forward tape) motion.
1b.	Data Signal	The Data signal indicates an output word is on the data channel data lines and is Ready for transfer.
2a.	R → O	The data word entered the O register from the channel. R → O FF enables a Reply signal.
2b.	Reply Signal	The 60026 indicates the receipt of the channel word which causes the channel to drop the Data signal (60026 then drops the Reply signal).
2c.	O Reg Gate	This sets 0.1 usec after the R → O FF sets, locking out further R → O transfer until the O Reg gate clears (at the same time as the R → O).

<u>Step</u>	<u>Event</u>	<u>Description</u>
2d.	Write Sync	The Write Sync FF is enabled by the Data signal and disabled by the timing chain at time 7. R → O transfer cannot take place when the Write Sync sets.
3.	Oscillator	The oscillator sends a timing pulse once every 25 usec to enable the timing chain and subsequent data transfer.
4.	Write Gate	This sets at time 0 and clears at time 7. This enables data transfer to the C registers and to the tape.
5.	C ¹ → C ²	Data word transfers from the C ¹ register to the C ² register during time 1. The C ² register conditions the C ¹ register to write in the non-return to zero method.
6.	O → C ¹	Data transfers from the O register to the C ¹ (write) register during time 2.
7.	Write Clock	Write Clock FF sets at time 3 and clears at time 7. The Write clock writes a "1" on the tape with each data word which is used for tape synchronization. If the clock bit is not present on tape, parity error occurs.

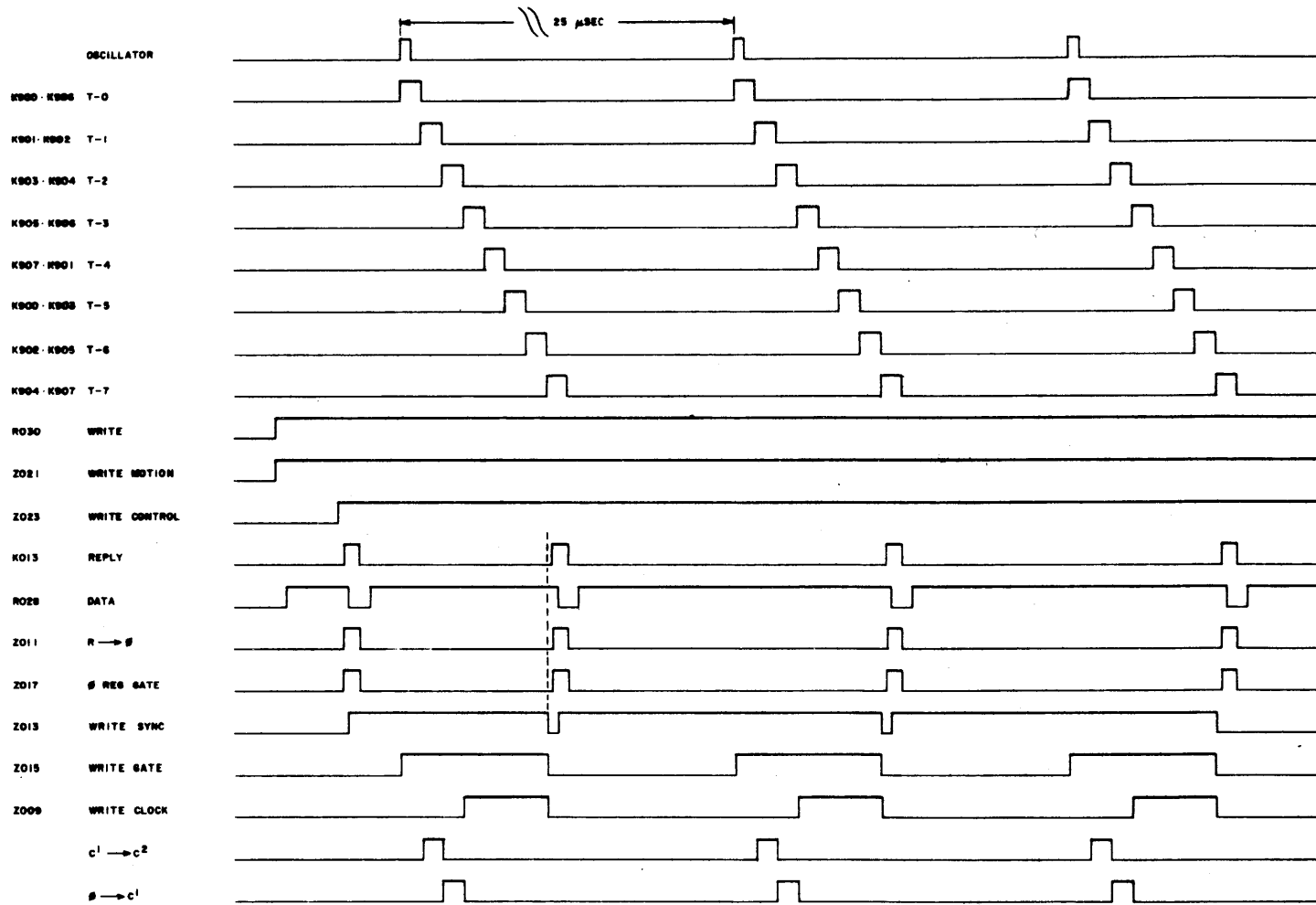

READ SEQUENCE

The following sequence of events indicates the primary controls active during a read operation. Read timing is illustrated on page 4-41

<u>Step</u>	<u>Event</u>	<u>Description</u>	<u>Step</u>	<u>Event</u>	<u>Description</u>
			3b.	Clear Counter	During time 3, prior to the transfer of the first data word to the channel, the timing chain enables clearing of the 60026 counter.
1a.	Read Signal	The Read signal places the connected tape unit in read status and enables read motion.	4a.	Strobe Tape Parity Error FF 2	If the tape is not at EOD and Tape Parity Error FF 1 is set, Tape Parity Error FF 2 will set at time 4, lighting the Tape Parity Error indicator.
1b.	Data Signal	The data channel sends a Data signal to the 60026 requesting a data word from the tape. Upon receipt of a word, the Data signal drops until the channel is ready to receive another word.	4b.	Increase Count	Each data word increases the counter during time 4 of the timing chain.
1c.	Read Motion	Read tape motion begins when the 60026 receives the Read signal and Data signal from the data channel.	5a.	EOD Lockout	The 60026 recognizes the End of Data word but does not transmit the word to the channel. The timing chain enables the lockout at time 6.
1d.	Clear X Register	Prior to each data word transfer, the timing chain enables the clearing of the 60026 X register.	5b.	Disable Counter Clear FF	The Clear Counter FF must be disabled during each data word transfer to continue counting.
1e.	Clear Tape Parity 1	Prior to transfer of the first data word, the timing pulse enables clearing of Tape Parity Error FF 1.	6a.	Reply Signal	The 60026 indicates the transmission of the tape data word to the channel which causes the channel to drop the Data signal. (The 60026 then drops the Reply signal.)
2.	H → X	During time 1 in the timing chain, the data word transfers from the tape unit to the X register in the 60026. The X register holds the data word for parity check, word count and comparison.	6b.	Read Ready	The timing chain enables the Read Ready FF at time 7 if the controller does not detect a SOD word or an EOD word and a data word has been gated to the T register by the Data Transfer FF at time 3. The Read Ready enables the Reply signal to the data channel.
3a.	Transfer Data	The Transfer Data FF enables data transfer from the tape unit to the T register at time 3. When the Reply is generated at time 7, the data word passes to the channel.	6c.	Save Block Word	During the transfer of each block of data, the block word is transferred from the X register to the O register. The block word is held in the O register as a reference word which may be used in a jig back to the previous block word.

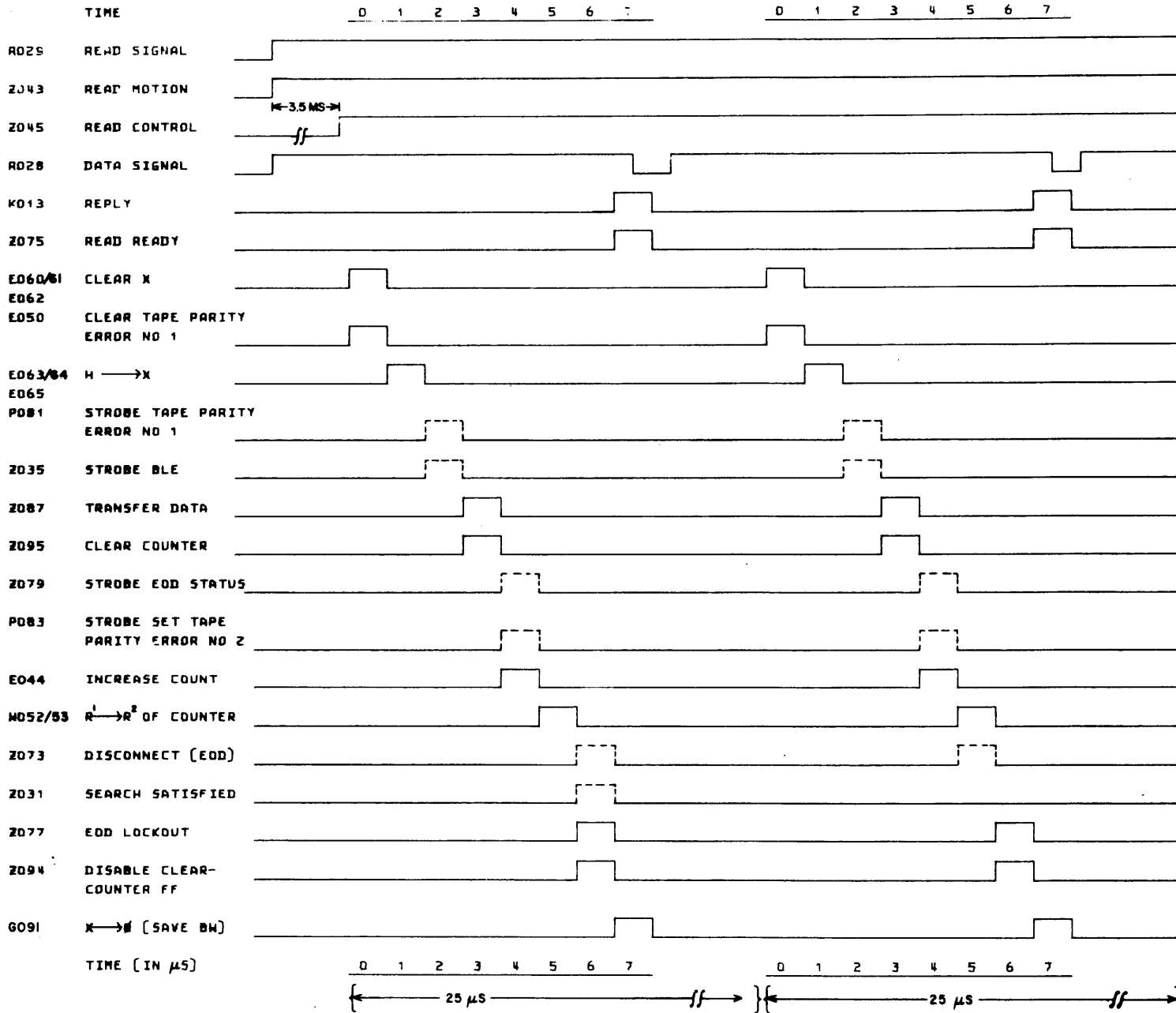

CONTROL DATA CORPORATION COMPUTER DIVISION AUTOMATED DRAFTING	TITLE READ TIMING DIAGRAM	PRODUCT SPEC. OPT. 60026	
		DRAWING NO.	REV.
TAPE NO. 6362	SHEET 15	PAGE 4-41	

TERM	LOC'N	SHEET	DESCRIPTION	TERM	LOC'N	SHEET	DESCRIPTION
D068	C71A	7		I006	C56B	3	
D070	C71B	7		I011	C57A	3	
D072	C70A	7		I800	K81A	4	
D074	C70B	7		S009	C57B	3	

TERM	LOC'N	SHEET	DESCRIPTION	TERM	LOC'N	SHEET	DESCRIPTION
S020	G71A	5		S024	G73A	5	
S021	G71B	5		S025	G73B	5	
S022	G72A	5		S026	G74A	5	
S023	G72B	5		S027	G74B	5	

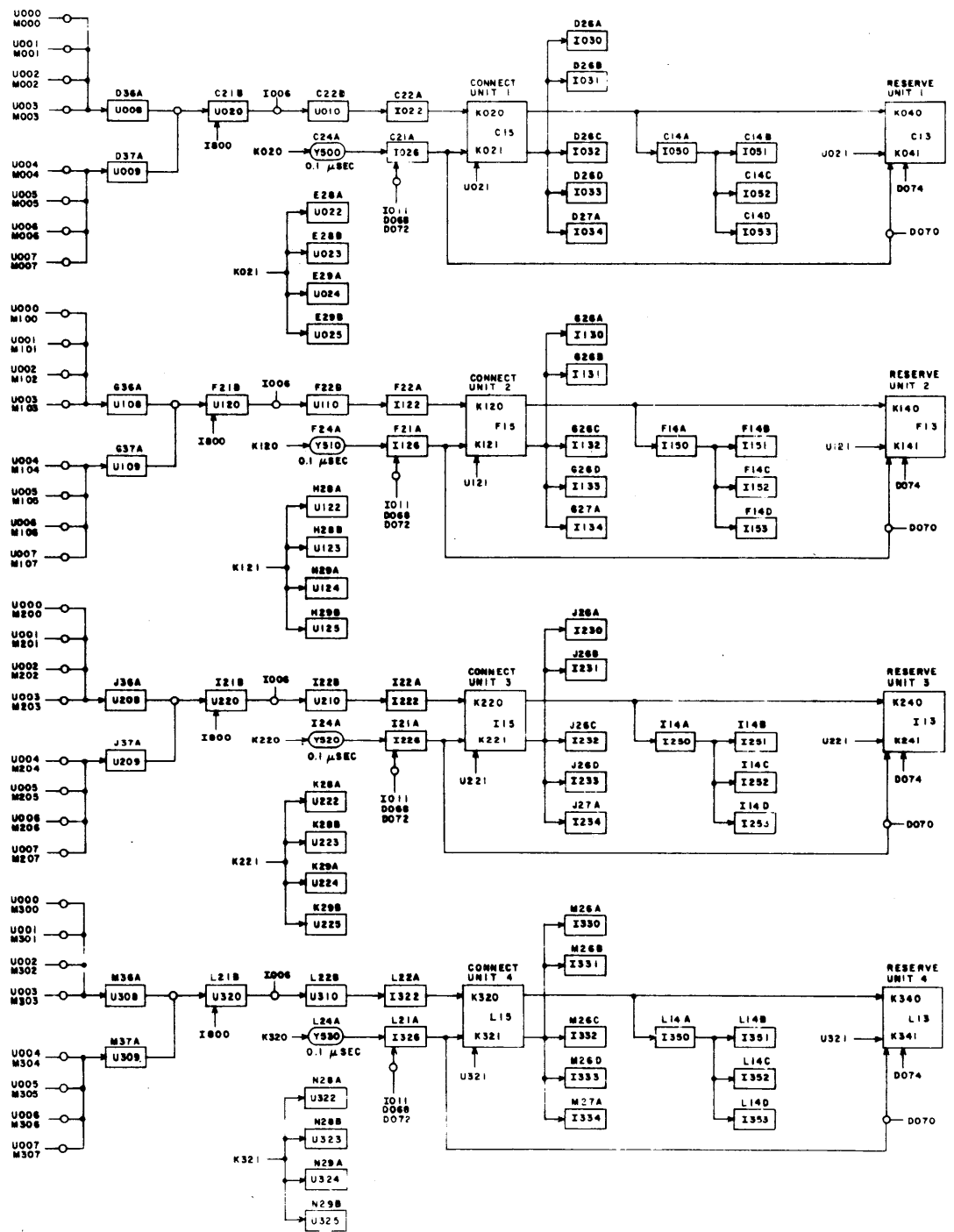

UNIT CONNECT TRANSLATIONS

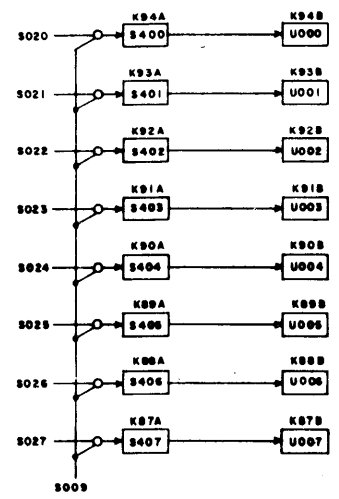

UNIT 1	UNIT 2	UNIT 3	UNIT 4
E01A	N01A	K01A	N01A
M000	M100	M000	M000
E01B	N01B	K01B	N01B
M001	M101	M001	M001
E02A	N02A	K02A	N02A
M002	M102	M002	M002
E02B	N02B	K02B	N02B
M003	M103	M003	M003
E03A	N03A	K03A	N03A
M004	M104	M004	M004
E03B	N03B	K03B	N03B
M005	M105	M005	M005
E04A	N04A	K04A	N04A
M006	M106	M006	M006
E04B	N04B	K04B	N04B
M007	M107	M007	M007

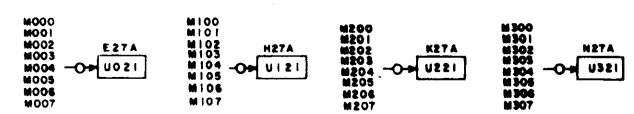

TERM	LOC'N	SHEET	DESCRIPTION	TERM	LOC'N	SHEET	DESCRIPTION
I030	D26A	16		I130	G26A	16	
I031	D26B	16		I131	G26B	16	

TERM	LOC'N	SHEET	DESCRIPTION	TERM	LOC'N	SHEET	DESCRIPTION
I230	J26A	16		I330	M26A	16	
I231	J26B	16		I331	M26B	16	

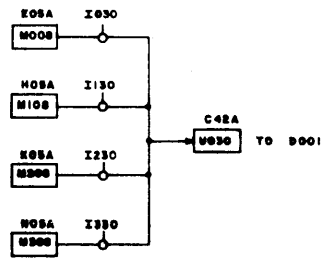
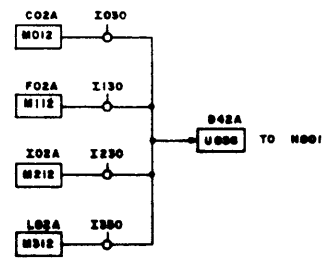
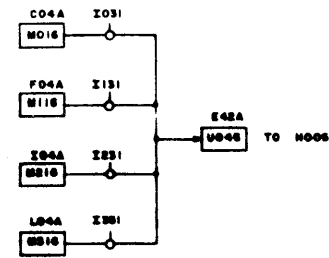
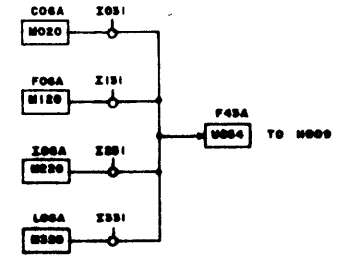
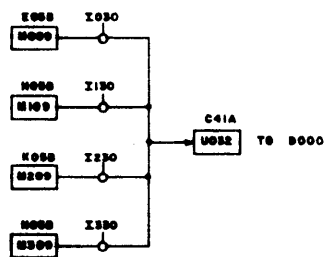
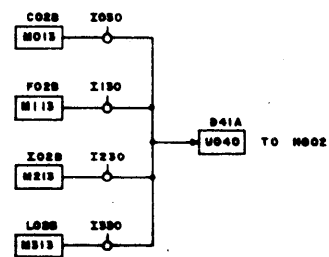
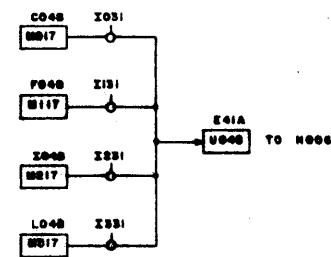
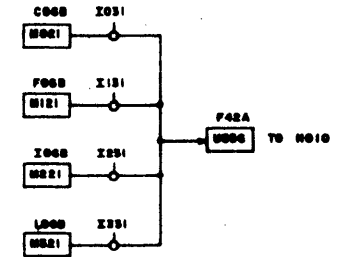
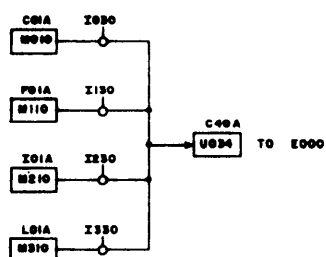
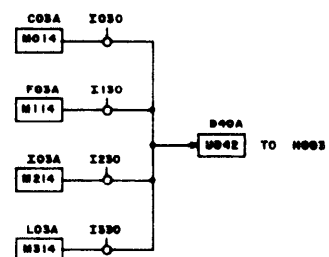
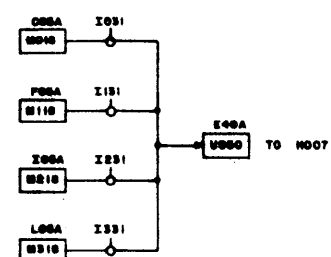
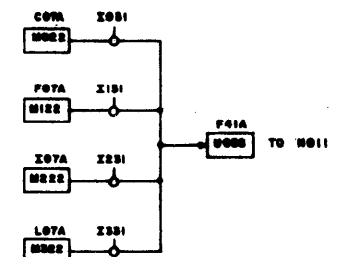
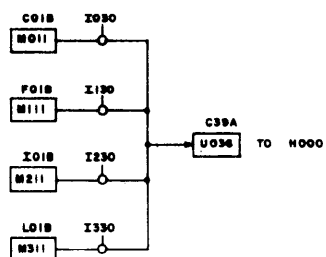
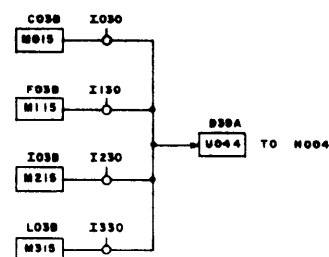
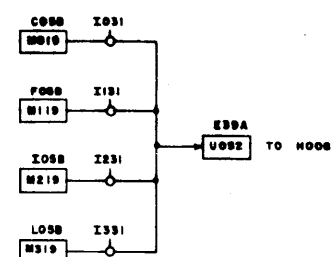
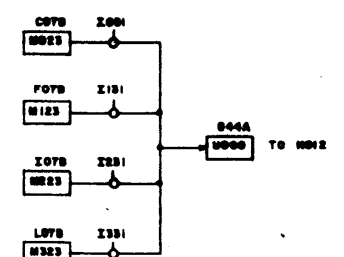
READY**BIT 1****BIT 5****BIT 9****BUSY****BIT 2****BIT 6****BIT 10****CLOCK****BIT 3****BIT 7****BIT 11****BIT 0****BIT 4****BIT 8****BIT 12**

TERM	LOC'N	SHEET	DESCRIPTION	TERM	LOC'N	SHEET	DESCRIPTION
I051	C14B	16		I151	F14B	16	
I052	C14C	16		I152	F14C	16	

TERM	LOC'N	SHEET	DESCRIPTION	TERM	LOC'N	SHEET	DESCRIPTION
I251	I14B	16		I351	L14B	16	
I252	I14C	16		I352	L14C	16	

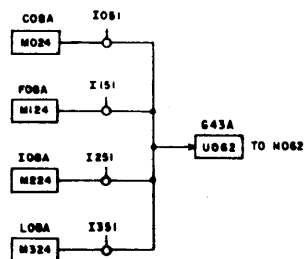
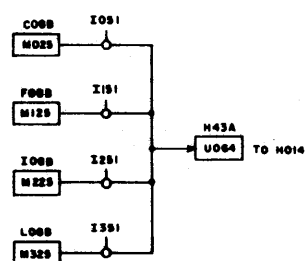
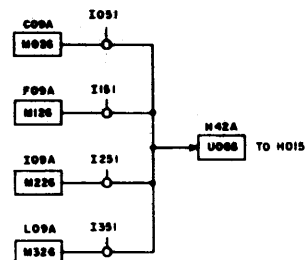
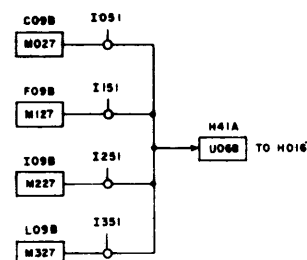
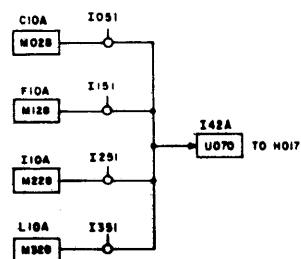
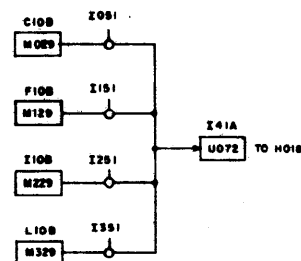
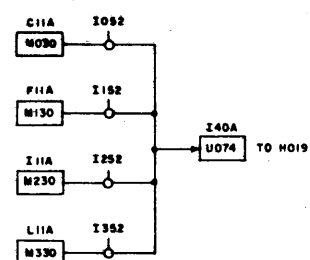
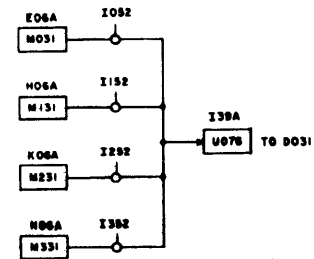
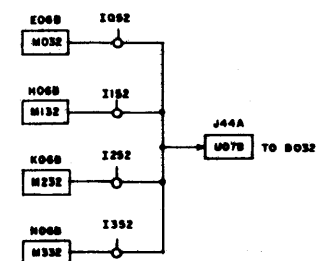
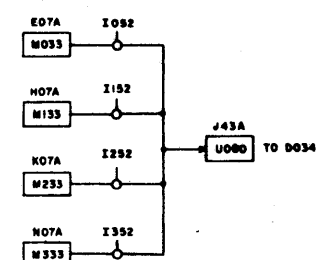
BIT 13**BIT 14****BIT 15****BIT 16****BIT 17****BLOCK****PARITY****LOAD POINT****END OF TAPE****WRITE ENABLE**

TERM	LOC'N	SHEET	DESCRIPTION	TERM	LOC'N	SHEET	DESCRIPTION
I032	D26C	16		I232	J26C	16	
I033	D26D	16		I233	J26D	16	
I132	G26C	16		I332	M26C	16	
I133	G26D	16		I333	M26D	16	

TERM	LOC'N	SHEET	DESCRIPTION	TERM	LOC'N	SHEET	DESCRIPTION
U022	E28A	16		U222	K28A	16	
U023	E28B	16		U223	K28B	16	
U122	H28A	16		U322	N28A	16	
U123	H28B	16		U323	N28B	16	

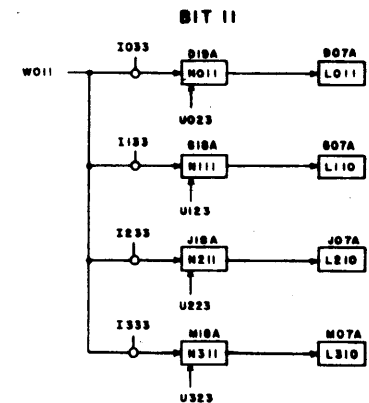
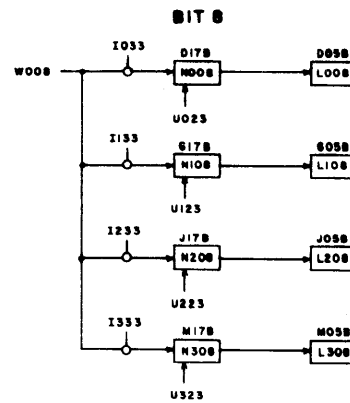
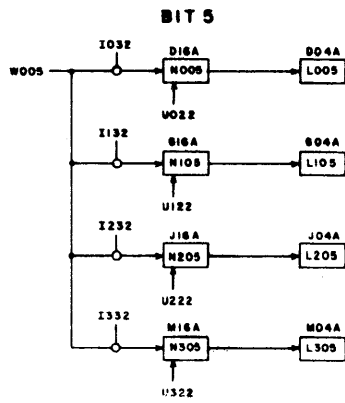
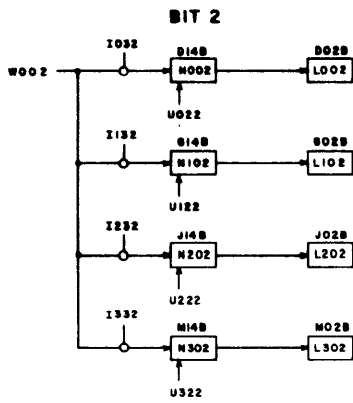
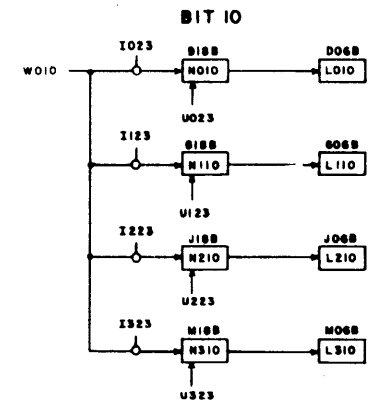
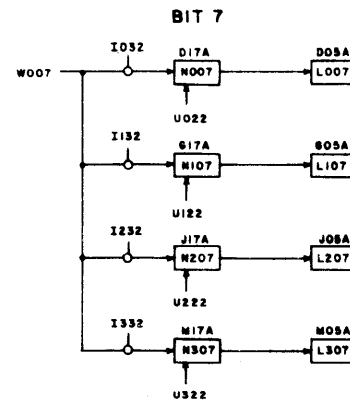
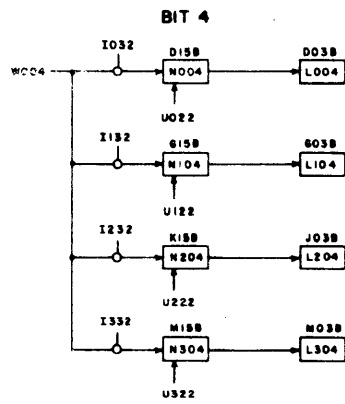
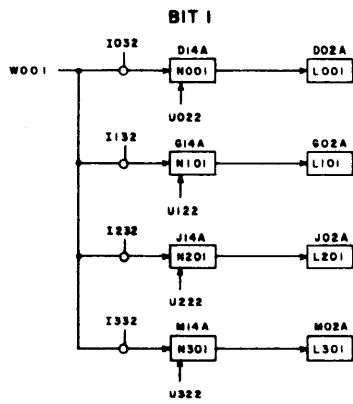
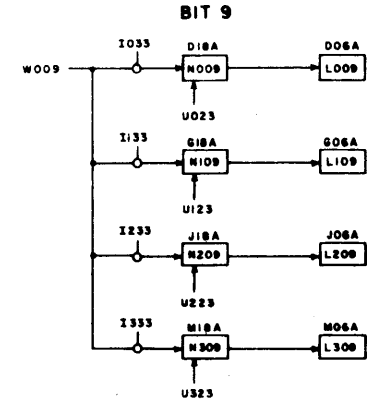
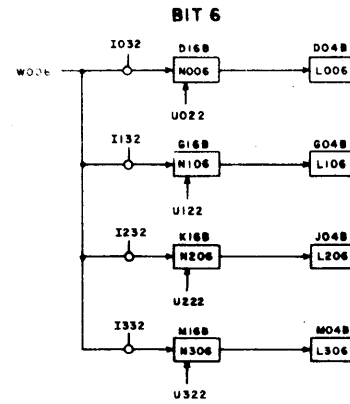
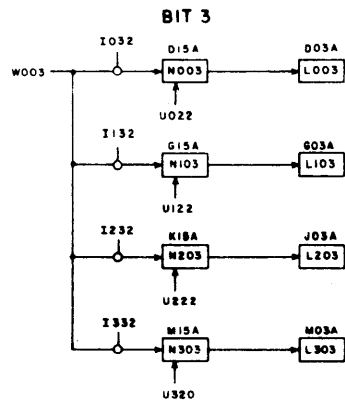
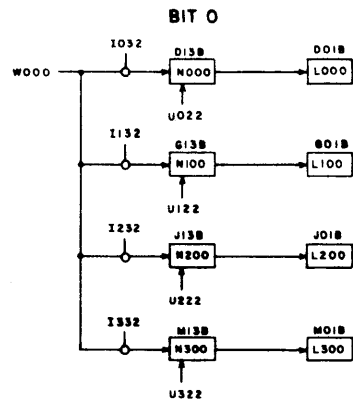

TERM	LOC'N	SHEET	DESCRIPTION	TERM	LOC'N	SHEET	DESCRIPTION
I033	D26D	16		I233	J26D	16	
I034	D27A	16		I234	J27A	16	
I133	G26D	16		I333	M26D	16	
I134	G27A	16		I334	M27A	16	

TERM	LOC'N	SHEET	DESCRIPTION	TERM	LOC'N	SHEET	DESCRIPTION
U023	E28B	16		U223	K28B	16	
U024	E29A	16		U224	K29A	16	
U123	H28B	16		U323	N28B	16	
U124	H29A	16		U324	N29A	16	

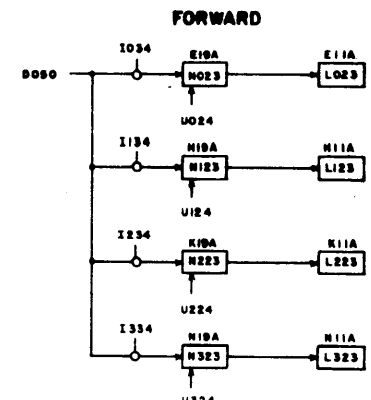
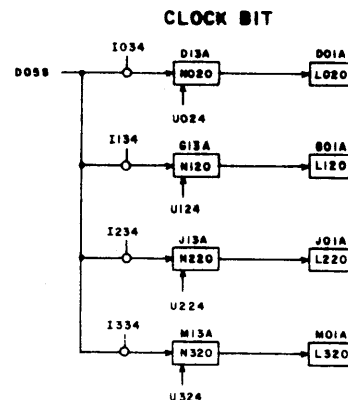
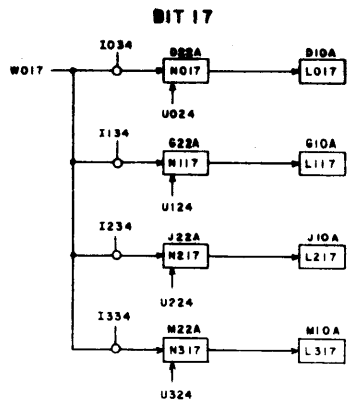
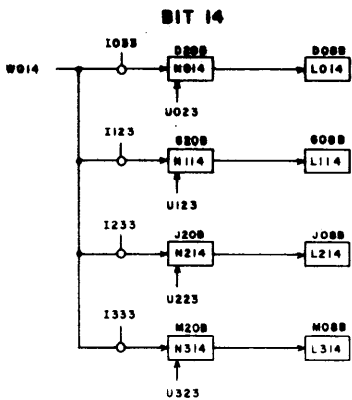
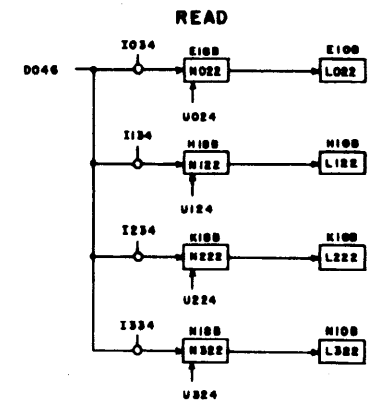
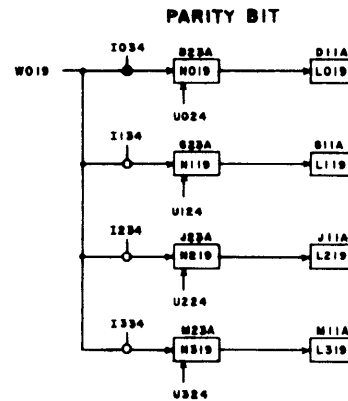
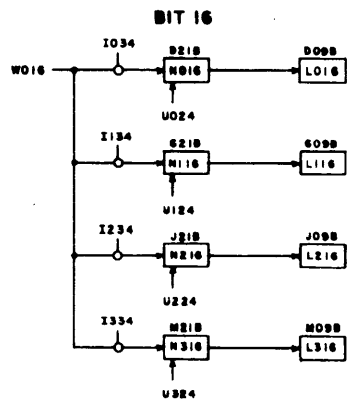
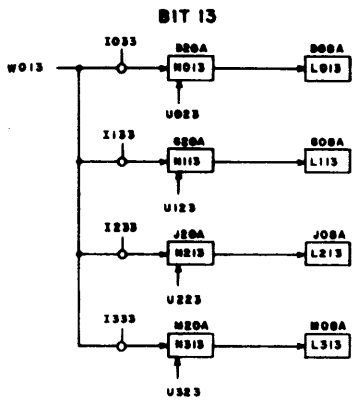
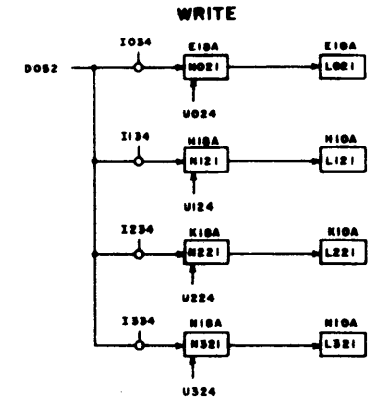
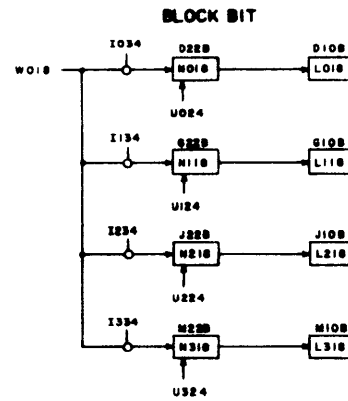
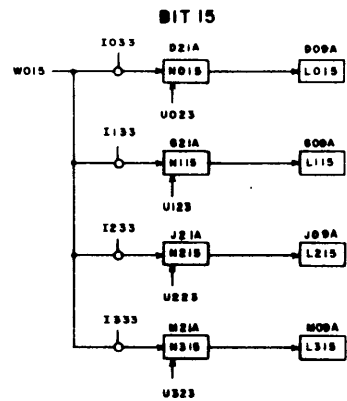
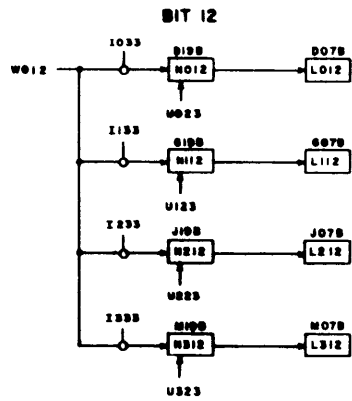

TERM	LOC'N	SHEET	DESCRIPTION	TERM	LOC'N	SHEET	DESCRIPTION
D021	C91C	5		I053	C14D	16	
D048	C74A	7		I153	F14D	16	
D054	C73B	7		I253	I14D	16	
D056	C72A	7		I353	L14D	16	

TERM	LOC'N	SHEET	DESCRIPTION	TERM	LOC'N	SHEET	DESCRIPTION
K041	C13C	16		U025	E29B	16	
K141	F13C	16		U125	H29B	16	
K241	I13C	16		U225	K29B	16	
K341	L13C	16		U325	N29B	16	

REVERSE

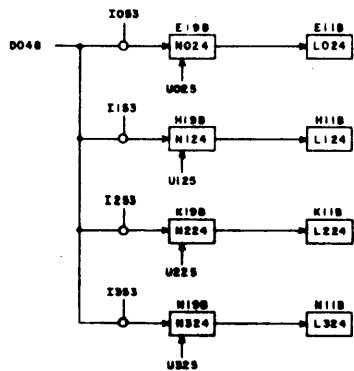

REWIND

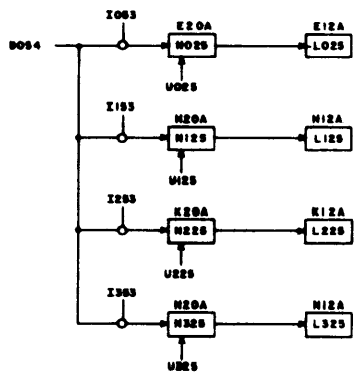

REWIND UNLOAD

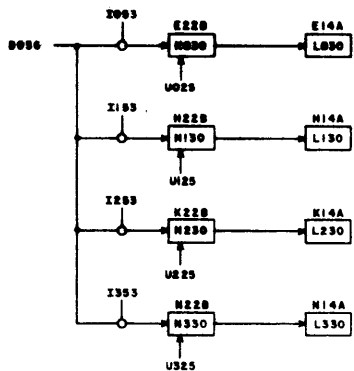

TAPE UNIT 0

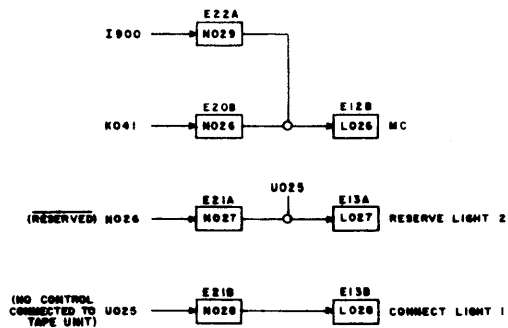

TAPE UNIT 2

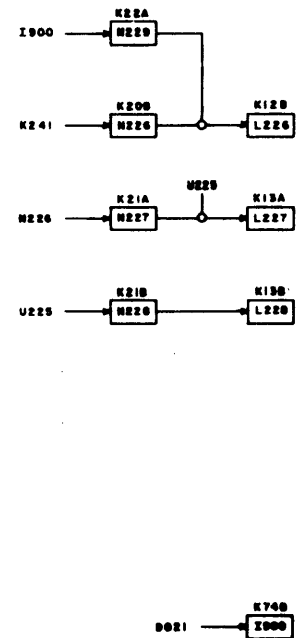

TAPE UNIT 1

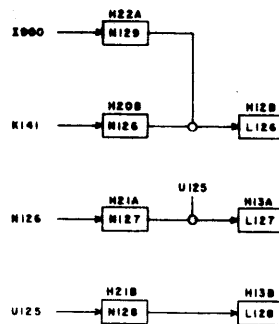

TAPE UNIT 3

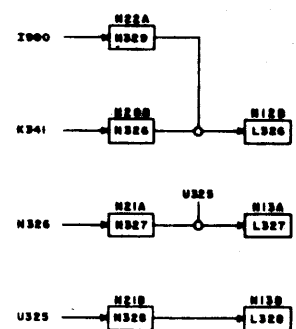

SECTION 5
PARTS LIST

MAINTENANCE PARTS LIST

The parts list provides the identification and ordering data necessary for the CONTROL DATA Special Option 60026 Magnetic Tape Controller.

Electrical Contents: Chassis assembly items are included except lead wires and bulk wire.

Hardware Contents: Chassis items are included except standard hardware such as screws, nuts, bolts, washers and raw material.

The chassis assembly and subassemblies are broken down into individual parts, listed in alphabetical rather than disassembly order.

The following publications contain information on printed circuit assemblies, peripheral cabinets, and power supplies necessary to complete a total parts listing of the equipment.

PUBLICATION	PUBLICATION NUMBER
Printed Circuit Card Assemblies	60040800
CDC Power Supply Manual	60120700
Peripheral Controller Cabinets Customer-Engineering Instruction Manual (includes Power Supply modification)	60097300

ORDERING OF PARTS

When ordering Control Data parts, include the following information: CDC drawing number, description, quantity needed and the equipment on which used. When ordering parts, use the procedure indicated by that vendor.

Special option 60026 Magnetic Tape Controller
CDC Dwg. No. 17772400

PARTS LIST
CHASSIS ASSEMBLY

CDC - DRAWING NUMBER	DESCRIPTION	QUANTITY EACH MACHINE
30006000	Bar, Mounting, Connector	
30507800	Bar, Mounting, Connector 49-94	
30507100	Bar, Mounting, Indicator Panel	
30507200	Bar, Mounting, Switch Panel	
30008700	Bracket, Angle, Chassis Frame	
30505800	Bracket, Mounting, Switch Panel	
30505700	Bracket, Mounting, Indicator Panel	
30600102	Cabinet Assembly, Refer to Publication Number 60097300	
30002201	Capacitor, Fixed, Electrolytic 10-10 UF, 50 WVDC	
17772400	Card Placement	
30000901	Connector, Receptacle, 61 Contacts	
30000100	Connector, Receptacle, 30 Contacts	
24512001	Connector, Receptacle, 24 Socket	
00865004	Grommet, Strained Relief, 61 Wire	
30104800	Hinge, Connector Panel	
17711000	Identification Plate	
00856101	Knob	
30002409	Light Indicator, Incandescent, White	
30503200	Member, Frame, Chassis, Side	
30507902	Member, Frame, Chassis, Side	
30008901	Member, Frame, Chassis, Top or Bottom	
30008902	Member, Frame, Chassis, Top or Bottom	
17772500	Panel, Light	
17772600	Panel, Blank	
17772700	Panel, Blank	
25164804	Plate, Filler, Chassis	
30010102	Plate, Designation, Narrow 49-71	
30013102	Plate, Designation, Narrow 72-94	
30010101	Plate, Designation, Narrow 01-23	
30013101	Plate, Designation, Narrow 24-46	
30008401	Plate, Designation, Wide 01-23	
30012801	Plate, Designation, Wide 24-46	
30008402	Plate, Designation, Wide 49-71	
30012802	Plate, Designation, Wide 72-94	

SPECIAL OPTION 60026 MAGNETIC TAPE CONTROLLER (Cont'd)
PARTS LIST

CDC - DRAWING NUMBER	DESCRIPTION	QUANTITY EACH MACHINE
30104100	Plate, Retaining, Connector, 8 Holes	
25151703	Power Supply Assembly, Refer to Publication Number 60097300	
30004600	Rubber, Special Section, Seal	
30504900	Seal, Strip, Metal	
30116500	Shield, Connector, Receptacle	
30000902	Socket Contact	
30005900	Spacer, Module 01-94	
30507700	Spacer, Module 49-94	
30508200	Spacer, Module 01-46	
30104600	Support, Connector Assembly	
30008102	Support, Retainer-Spacer	
30506300	Stud Extension	
17772400	Wire Tabs	

PARTS LIST
PRINTED CIRCUIT CARD ASSEMBLY

DATE: _____

CDC - DRAWING NUMBER	DESCRIPTION	QUANTITY EACH MACHINE
30908201	Printed Circuit Card Assembly; Type CA21	
30912201	Printed Circuit Card Assembly; Type CA31	
30921801	Printed Circuit Card Assembly; Type CA55	
30924601	Printed Circuit Card Assembly; Type CA62	
30929801	Printed Circuit Card Assembly; Type CA75	
30930201	Printed Circuit Card Assembly; Type CA76	
30931801	Printed Circuit Card Assembly; Type CA80	
30932201	Printed Circuit Card Assembly; Type CA81	
30933401	Printed Circuit Card Assembly; Type CA84	
30935401	Printed Circuit Card Assembly; Type CA89	
30938601	Printed Circuit Card Assembly; Type CA97	
30942201	Printed Circuit Card Assembly; Type HA05	
30943001	Printed Circuit Card Assembly; Type HA07	
30943801	Printed Circuit Card Assembly; Type HA09	
30944601	Printed Circuit Card Assembly; Type HA11	
30947801	Printed Circuit Card Assembly; Type HA19	
30952201	Printed Circuit Card Assembly; Type HA30	
30957801	Printed Circuit Card Assembly; Type HA46	
30958201	Printed Circuit Card Assembly; Type HA47	
30958601	Printed Circuit Card Assembly; Type HA48	
31700201	Printed Circuit Card Assembly; Type K11	
31700601	Printed Circuit Card Assembly; Type K12	
31701001	Printed Circuit Card Assembly; Type K13	
31701401	Printed Circuit Card Assembly; Type K14	
31701801	Printed Circuit Card Assembly; Type K16	
31702601	Printed Circuit Card Assembly; Type K22	
31711801	Printed Circuit Card Assembly; Type K23	
31703001	Printed Circuit Card Assembly; Type K24	
31703401	Printed Circuit Card Assembly; Type K25	
31703801	Printed Circuit Card Assembly; Type K26	
31704201	Printed Circuit Card Assembly; Type K27	
31704601	Printed Circuit Card Assembly; Type K29	

PARTS LIST
PRINTED CIRCUIT CARD ASSEMBLY (Cont'd)

DATE: _____

CDC - DRAWING NUMBER	DESCRIPTION	QUANTITY EACH MACHINE
31709401	Printed Circuit Card Assembly; Type K31	
31705001	Printed Circuit Card Assembly; Type K32	
31709801	Printed Circuit Card Assembly; Type K33	
31710201	Printed Circuit Card Assembly; Type K35	
31705801	Printed Circuit Card Assembly; Type K36	
31711401	Printed Circuit Card Assembly; Type K38	
31707001	Printed Circuit Card Assembly; Type K58	
31708601	Printed Circuit Card Assembly; Type K67	
31710601	Printed Circuit Card Assembly; Type K68	
31711001	Printed Circuit Card Assembly; Type K69	
31709001	Printed Circuit Card Assembly; Type K71	