

3000

SERIES
PERIPHERAL EQUIPMENT

REFERENCE MANUAL

VOLUME 2

CONTROL DATA
CORPORATION

RECORD of REVISIONS

REVISION	NOTES
A (12-30-65)	Publication Change Order CA 12209 adds Section D (3127-A) to Part I, Volume 1, and Section A (3436-A/3637-A) to Part V, Volume 1. This change order does not affect any Product Designation. Page iii changed.
B (5-12-66)	Publication Change Order 13374 adds Section D (3458-A) to Part III, Volume 1. This change order does not affect any Product Designation. Pages iii and v changed.
C (6-17-66)	Publication Change Order 13951. Part II, Volume 1, Equipment sections revised. Sections A (3446-A/3644-A) and B (3245-A) revised. Sections C and D (3248-A/3447-A/3649-A) combined and Section D (3142 Card Reader Controller) added. This change order does not affect any Product Designation. This printing obsoletes Part II Card Equipment (Sections A, B, C, D, and Z) only, which are replaced with Rev. Packet C.
D (11-10-66)	Publication Change Order 15140. Card Equipment, Section D (3142) pages D-13, D-14, and Z-5 revised. Visual Recording Equipment, Section D (3458-A) pages D-36 and D-37 revised. This change order incorporates Field Change Order 14742.
E (1-13-67)	Publication Change Order 15567 adds Section B (363X-A) to Part V, Volume 1 (Mass Storage Equipment section).
F (3-9-67)	Publication Change Order 15982. Additions and corrections to Section D (3458-A) Part III, Volume 1. Pages D-iii through D-57 revised.
G (5-6-67)	Publication Change Order 16355. No Product Designation change. The following pages were revised: Frontispiece in Section A (3436-A/3637-A) Part V and page C-3, Section C (3293-A) Part III. Section C (3234-A) pages C-iii thru C-68 were added to Part V. This printing obsoletes Pub. No. 60167800 (3234 Mass Storage Subsystem Reference Manual) which is incorporated in this manual.
H (7-1-67)	Publication Change Order 16618 Section E (3128-A/B) added to Part I, Volume 1. At this printing the Peripheral Equipment Reference Manual becomes two volumes: Vol. I (Parts I and II). Vol. 2 (Parts III through VI).
J, K (10-3-67)	Publication Change Order 17017, Vol. 1, Part II, Section C (3248-A/3447-A/3649-A) page C-7 revised. Vol. 2, Part V, Section A (3436-A/3637-A) revised. This printing obsoletes Pub. No. 60114300 (3436-A/3637-A Drum Storage Controller). Publication Change Order 17265. Volume 1, Part I, Section F (Magnetic Tape Controller) pages F-1 through F-16 added.
L (11-8-67)	Publication Change Order 17840. Volume 2, Part III, Section E (3254-A Line Printer), pages E-1 through E-18 added. This printing obsoletes Pub. No. 60182300, Rev 01 (3254-A/B Line Printer Reference Manual).
M (1-15-68)	Publication Change Order 18273. Volume 2, Part V, Section C (3234-A). Pages C-7, C-10 and C-36 revised.

FORM CA230 REV. 1-67

Address comments concerning this manual to:

Control Data Corporation
 Technical Publications Department
 4201 North Lexington Avenue
 St. Paul, Minnesota 55112

or use Comment Sheet in the back of this manual.

Pub No. 60108800
 © 1965, 1966, 1967, 1968
 by Control Data Corporation
 Printed in United States of America

GENERAL CONTENTS

- VOLUME 1 PART I. MAGNETIC TAPE EQUIPMENT
- A. 362X-A/B Magnetic Tape Controllers
 - B. 342X-A Magnetic Tape Controller
 - C. 3228-A/3229-A Magnetic Tape Controllers
 - D. 3127-A Magnetic Tape Controller
 - E. 3128-A/B Magnetic Tape Controller
 - F. 3121-A/B Magnetic Tape Controller
 - Z. Supplementary Information, Magnetic Tape Equipment
- PART II. CARD EQUIPMENT
- A. 3446-A/3644-A Card Punch Controllers
 - B. 3245-A Card Punch Controller
 - C. 3248-A/3447-A/3649-A Card Reader Controllers
 - D. 3142-A Card Reader Controller
 - Z. Supplementary Information, Card Equipment
- VOLUME 2 PART III. VISUAL RECORDING EQUIPMENT
- A. 3256-A/3659-A Line Printer Controllers
 - B. 3692-A Program Controlled Input/Output Typewriter
 - C. 3293-A Incremental Plotter
 - D. 3458-A Printer Controller
 - E. 3254-A Line Printer
- PART IV. PAPER TAPE EQUIPMENT
- A. 3691-A/B Paper Tape Reader/Punch
- PART V. MASS STORAGE EQUIPMENT
- A. 3436/3637 Drum Storage Controllers
 - B. 363X-A Disk File Controller
 - C. 3234-A Mass Storage Controller
- PART VI. INTERFACE EQUIPMENT
- A. 3681-A Data Channel Converter
 - B. 3682-A Satellite Coupler

SECTION A

3256-A/3659-A LINE PRINTER CONTROLLERS

CONTENTS

Functional Description	A-1	Parity Checking (Transmission)	A-8
3256 Controller	A-1	3256 Error Checking Option	A-10
3659 Controller	A-2	Codes	A-10
Print Operation	A-2	Connect Code	A-11
Paper Advance	A-3	Function Codes	A-12
Buffer Memory	A-4	Status Codes	A-15
Printing Rate	A-4	Character Codes	A-16
Connect	A-4	Switches and Indicators	A-19
Function	A-5	Operation and Programming	A-21
Interrupts	A-6	Operation	A-21
Status	A-7	Programming Considerations	A-24

FIGURES

A-1 Typical Configuration	A-1	A-3 Spacing Example	A-22
A-2 3659 Controller Switch and Indicator Panel	A-18		

TABLES

A-1 Connect, Function, and Status Codes	A-10	A-3 Characters Arranged by Character Rows	A-17
A-2 Characters Arranged by Internal BCD Codes	A-16		

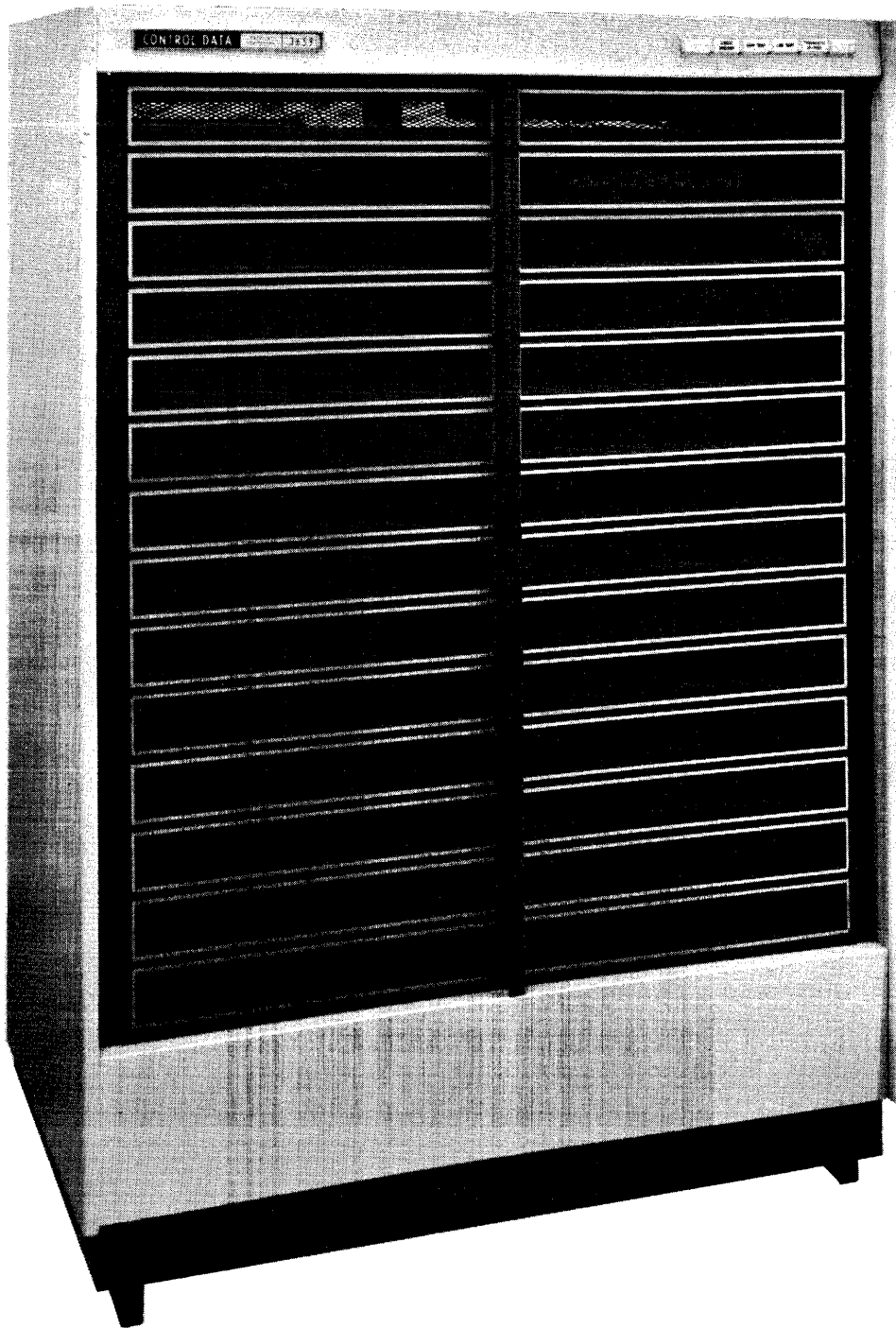

3659 LINE PRINTER CONTROLLER

3256-A/3659-A LINE PRINTER CONTROLLERS

The CONTROL DATA* 3256 and 3659 Line Printer Controllers facilitate printing of data received from standard 3000 Series data channels. Either controller may be used to operate the CONTROL DATA 501 Printer (1,000 lines per minute) or the 505 Printer (500 lines per minute). (See Figure A-1.)

This section describes the disassembly of data received from the data channel. It also describes the Connect, Function, and Status codes and provides pertinent programming information.

FUNCTIONAL DESCRIPTION

3256 CONTROLLER

The 3256 Controller has one write control. This control can be physically attached** to one 3000 Series data channel. Thus, the 3256 Controller can be connected by the channel at any time without the possibility of a connect reject.

A special error checking option may be installed in the 3256 Controller. See 3256 Error Checking Option for programming information.

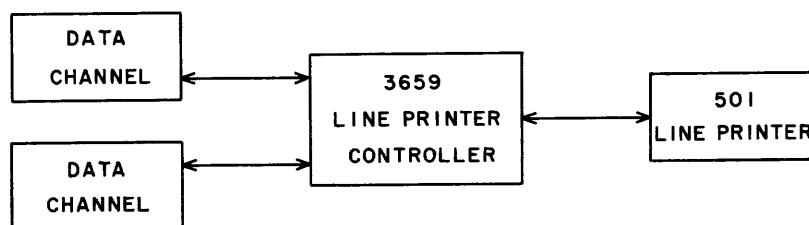

Figure A-1. Typical Configuration

*Registered trademark of Control Data Corporation

**Though a control may be physically attached to a data channel, it does not respond to Function or Input/Output instructions until it has been connected by a Connect instruction.

3659 CONTROLLER

The 3659 Controller has two write controls. Each control can be physically attached to one 3000 Series data channel. Either channel, through its associated control, can communicate with the printer provided it is not in use or reserved by the other channel.

The data channels serving the 3659 Controller need not be associated with the same central processor.

With the preceding exceptions, the following information is applicable to both controllers.

PRINT OPERATION

The printer system (controller plus basic printer) disassembles a series of 12-bit bytes from the data channel into 6-bit BCD codes and prints a character corresponding to each code.

In a printed line, the character designated by the upper 6 bits of a byte precedes the character corresponding to the lower 6 bits. Each line of print contains up to 136 characters; thus, 68 bytes are required to form a full line.

The controller forms each line of print in a buffer memory. After 68 bytes have been received, the controller temporarily stops accepting data and begins the actual print operation. When the line has been printed, the controller starts to form the next line in the buffer memory. After a line is printed, the paper is automatically advanced one space if not other spacing operation is programmed.

If the data channel terminates an Output operation before a full line is formed, the partial line is printed. A new Output operation starts a new line.

Disassembly is automatically suppressed when a 6-bit Character Output operation is initiated by one of the following instructions:*

- 1) OUTC Character-Addressed Output from Storage in which H (bit 18) = 0
- 2) OTAC Output, Character from A

During this type of Output operation, the upper 6 bits of each byte contain zeros. The printer system accepts only the lower 6 bits of each byte; thus a total of 136 bytes are required to form a full line. When the data channel terminates the Character Output operation, the printer system returns to the normal Disassembly mode of operation.

*Applicable to 3100/3200 systems only

PAPER ADVANCE

The printer system has a very flexible paper advancing system that is controlled by function codes. Certain function codes, such as Single Space and Double Space, cause spacing operations to occur directly. Other codes turn spacing control over to the printer's format tape reader. If no spacing operations are programmed by means of the function codes, the printer automatically single spaces after each line is printed. The eight-level format tape reader can be used to provide any page format desired. A loop of punched tape is the controlling medium. Loops of various lengths can be used to provide different page lengths.

A tape loop contains one frame for each line on the page format. During any spacing operation, the format tape advances one frame each time the paper advances one line. Paper spacing can be programmed to begin automatically after a line is printed or upon receipt of certain function codes. Once a spacing operation begins, the paper (and the tape loop) advances until a hole is detected in a preselected position on the tape.

There are two main types of spacing codes: preprint spacing codes and postprint spacing codes.

A preprint spacing code initiates a one-time spacing operation. An example of these codes is Select Format Tape Level 1 for Preprint Spacing (code 0021). This code causes the paper to advance until a hole is detected in the first level of the tape loop.

Postprint spacing codes setup automatic spacing operations which occur after each line is printed. These codes remain in effect until cleared. An example of these codes is Select Format Tape Level 5 for Postprint Spacing (code 0005). When this code is in effect, a spacing operation begins after each line is printed. The paper advances until a hole is detected in the fifth level of the tape loop.

Tape levels one through six are used to control preprint and postprint spacing operations. A punch in level seven is used to designate the last line of a form. A function code is available that advances the paper to the last line. The top of the form is designated by a punch in level eight. The printer can be programmed to advance paper until the reader senses a hole in level eight.

The section on function codes following Table A-1 describes each of the paper spacing codes. Preparation of the format tape is discussed in the Operation and Programming section.

BUFFER MEMORY

These controllers store one line of data (up to 136 characters) in a magnetic core memory until the data is printed. This feature permits the data channel to load one line of characters into the memory at high speed. The data channel can then disconnect to service another device while the slower printing operation is being performed.

PRINTING RATE

A printer system using the 501 Printer can operate at a maximum rate of 1,000 lines per minute. The 505 Printer can print at rates up to 500 lines per minute. To maintain maximum printing rates for either printer, certain programming restrictions must be observed. These restrictions are outlined in the Operation and Programming section.

CONNECT

A control must be connected to its data channel before it can respond to either a Select/Function instruction or a Write instruction. The connection is accomplished by the Connect instruction; the Connect code (N000) is the lower 12 bits of this instruction. Each control examines every Connect code transmitted from its attached data channel. A control connects and returns a Reply* to the data channel if:

- 1) The printer is not connected to or reserved by the other data channel.**
- 2) The N portion of the Connect code matches the setting of the Equipment Number switch.
- 3) A transmission parity error is not detected.

If the 3659 Controller is connected to or reserved by another data channel or if a Write operation is still in process, a Reject signal*** is returned to the data channel requesting the connect. Equipment status is also made available to that data channel so that the cause for the reject may be determined.

If the N portion of the Connect code does not match the setting of the Equipment Number switch, neither a Reject nor a Reply is returned to the channel from this equipment. Equipment status is not made available to the channel. If the controller is already connected, it automatically disconnects. It does, however, remain reserved for that

*A Reply signal tells the central processor to process the next instruction.

**3659 Controller (the two-channel controller) only

***A Reject signal tells the central processor to read the next instruction at the reject jump address contained in the Connect instruction.

channel until released, cleared, or given a new equipment number. If neither a Reply nor a Reject is returned to the data channel from any of its attached equipments within 100 microseconds, the central processor generates an Internal Reject.

If a parity error is detected in a Connect code, the device does not connect* and neither a Reject nor a Reply is returned to the data channel. Instead, a red indicator in the Equipment Number switch of each equipment detecting the error lights. These parity error conditions must be cleared by either a Clear Channel instruction or a Master Clear prior to a new connect attempt.

The 3659 Controller contains a channel reservation feature. It may be unconnected and unreserved, connected to a data channel, or reserved by a data channel.

An unconnected and unreserved printer may be connected by any channel serving the controller. Once a channel is connected to a particular unit (i. e., a communication path is established), the printer remains reserved for that channel even though the channel disconnects the printer by connecting (or attempting to connect) to another unit or equipment. Once the printer is reserved by a channel, no other channel has access to it. Since neither a Clear Channel instruction nor a Master Clear from the nonreserving channel has an effect on the printer system, care must be taken to release it when it is not essential to the current program. If more than one channel attempts to connect simultaneously, a scanner determines the channel to be connected.

FUNCTION

Function codes are used to prepare the connected control and/or printer for an Output operation (they have no effect on unconnected controls). Function codes comprise the lower 12 bits of a Select/Function instruction and are transmitted to the control on the 12 data lines. See Table A-1 for a complete list of function codes. A detailed description of each code follows the table.

There are two classifications of function codes: operating and nonoperating. Operating codes** cause paper motion and are divided into preprint and postprint codes.

Preprint operating codes initiate paper motion, cause the control to become Busy, and are self-clearing. These codes include: Single Space, Double Space, Advance to Last Line, Page Eject, and Select Format Tape Level X for Preprint Spacing.

*If the device is connected, it automatically disconnects.

**Operating codes cause the control to become Busy.

Postprint codes do not initiate paper motion. Instead, paper motion is initiated automatically following the printing of a line of data. The postprint codes are Auto Page Eject and Select Format Tape Level X for Postprint Spacing. They may be cleared by the Clear Format Selection code, the Select Format Tape Level X for Preprint Spacing code, a Clear Channel instruction, or a Master Clear.

The remaining codes are considered nonoperating. They are not accepted during a printing operation but are accepted while an operating function is being executed.

A control examines only one code at a time. First, it checks for parity errors. If none are found, it returns a Reply provided the function code is legal and the request can be performed. If the code is illegal or if it cannot be performed, a Reject is returned to the channel.

If a parity error is detected, the requested function is not performed, a Parity Error signal is returned to the data channel, and a red indicator in the Equipment Number switch lights. Since neither a Reply nor a Reject is returned to the data channel, the central processor generates an Internal Reject after a wait of 100 microseconds.

These parity error indications must be cleared by either a Clear Channel instruction or a Master Clear. The equipment must then be reconnected before a new function code can be examined by the control.

INTERRUPTS

Interrupts provide a means for attaining optimum utilization of a system's capabilities. Basically, the system interrupts (halts) the main program and initiates an interrupt processing program* when an Interrupt signal is detected by the processor.

The controllers can be programmed to send an Interrupt signal to the processor when any one of the conditions specified by the three interrupts** materializes.

*See the system reference manual for the addresses pertinent to interrupt processing.

**See explanation of function codes following Table A-1 for a list of these conditions.

A Select Interrupt code permits the controller to consider as a group* several of the operating conditions which may occur. If a specific interrupt has been selected and if at least one of the conditions specified by it occurs in the connected unit, the controller sends an Interrupt signal to the processor. If the interrupt system in the processor has been set to recognize the interrupt, the main program is interrupted and control is transferred to a specific program address. Status sensing and followup operations may follow. If desired, control may be returned to the main program by an appropriate Jump instruction located at the close of the interrupt processing program.

If the processor's interrupt system has not been enabled, it is still possible to sense for these conditions via Sense Status and Copy Status instructions written into the main program.

Regardless of which of the above actions is followed, the Interrupt signal remains up until cleared by reselecting the interrupt, selecting release, or master clearing the system. The Interrupt signal is transmitted on the equipment's interrupt line via the data channel currently connected to or reserving the equipment or, in the case of a single-channel controller, via the physically connected data channel whether or not the channel is currently servicing the equipment.

The eight-position (0-7) Equipment Number switch determines the number of the line on which the Interrupt signal is transmitted. For example, if the Equipment Number switch is set at 5, all Interrupt signals coming from this control are transmitted on interrupt line 5. Since each equipment attached to a data channel has a unique equipment number, each uses a different interrupt line. A Channel Product Register Jump Instruction** or a Copy Status Instruction*** can identify the equipment sending the Interrupt signal by inspecting the interrupt lines.

STATUS

Status codes permit the monitoring of several control/unit operating conditions. These codes are made available to the data channel over 12 status lines following a connect or a rejected connect attempt. Sense Status and Copy Status instructions make these codes available to the central processor.

*See explanation of function codes following Table A-1 for a breakdown of the three possible groups.

**3600/3800 systems

***3100/3200/3400 systems

See Table A-1 for a complete list of these codes. If two or more conditions exist simultaneously, the Status Response code is the sum of the individual codes. A detailed description of each code follows the table.

PARITY CHECKING (TRANSMISSION)

Connect codes, function codes, and data are transmitted between the data channel and the controller in odd parity (i. e., the number of "1" bits transmitted must be odd. If the number of "1" bits in a data byte is even, a "1" is transmitted on the parity line to make the total number of "1" bits odd.* If the number of "1" bits in the data byte is odd, the "1" is not transmitted on the parity line.

A transmission parity error exists if the total number of "1" bits transmitted on the 12 data lines plus the parity line is even, indicating that a bit has been lost or picked up.

Parity Error in a Connect Code

If a parity error is detected in a Connect code, the device does not connect** and neither a Reject nor a Reply is returned to the data channel. Instead, a red indicator in the Equipment Number switch of each equipment detecting the error lights. These parity error conditions must be cleared by either a Clear Channel instruction or a Master Clear prior to a new connect attempt.

Parity Error in a Function Code

If a parity error is detected, the requested functions are not performed, a Parity Error signal is returned to the data channel, and a red indicator in the Equipment Number switch lights. Since neither a Reject or a Reply is returned to the data channel, the central processor generates an Internal Reject after a wait of 100 microseconds. These parity error indications must be cleared by a Clear Channel instruction or a Master Clear.*** The equipment must then be reconnected before a new function code can be examined by the controller.

*Do not confuse this line with the parity error line.

**If the device is connected, it automatically disconnects.

***Though operations may continue normally, the validity of a new function code and/or data prior to a Master Clear or Clear Channel instruction is questionable.

Parity Error in Output Data

If a transmission parity error is detected during a Write operation, the control sends both a Reply and a Parity Error signal to the data channel. A red indicator in the Equipment Number switch also lights.

The data is stored in printer memory but not printed. Three options are available at this point.

- 1) A Clear Channel instruction or a Master Clear may be executed. In this case, the control must be reconnected, the appropriate function reselected, and the line of data transmitted to the printer a second time.
- 2) The STOP switch and then the START switch may be pressed. In this case, only the line of data in printer memory is printed.
- 3) The PARITY ERROR OVERRIDE switch may be pressed. In this mode, printing continues without regard to parity errors. In the last two cases, the validity of the data printed is questionable.

Parity error indications are cleared by pressing the STOP and START switches in sequence, a Clear Channel instruction, or a Master Clear. If the stop/start sequence is used, the input/output parity bit in the data channel remains set.

Input/Output Parity Error Bit in the Data Channel

The input/output parity error bit is set whenever a transmission parity error is detected. If the error is detected by the external equipment, the bit is set by the Parity Error signal.

In 3400/3600/3800 systems, an Interrupt signal is generated when this bit sets. If the interrupt system has not been set to detect the setting of this bit, the bit may be sensed to detect parity error conditions.

In 3100/3200 systems, the bit must be sensed if transmission parity error conditions are to be detected by the central processor.

Refer to the appropriate system reference manual for more information on the input/output parity error bit.

3256 ERROR CHECKING OPTION

An optional error checking feature is available for the 3256 Controller. This option automatically checks each line printed for:

- 1) A positive printout of a character* in each column programmed for printing.
- 2) An erroneous printout of a character in a column not programmed for printing.
- 3) A printout of more than one character per column (overprint).

If a print error is detected, the following occurs:

- 1) A "1" is sent on the error status line (status bit 10).
- 2) The controller sends an Interrupt signal if Interrupt on Abnormal End of Operation has been selected.

CODES

Tables A-1 and A-2 list the codes applicable to the printer system. Connect, Function and Status codes are defined in the section following Table A-1. In all discussion of codes, bit 0 is the rightmost bit.

TABLE A-1. CONNECT, FUNCTION, AND STATUS CODES

CONNECT	
Connect Printer	N000**
FUNCTION	
Release and Disconnect	0000, 0040
Single Space	0001
Double Space	0002
Advance to Last Line	0003
Page Eject	0004
Auto Page Eject	0005
Suppress Space	0006
Clear Format Selection	0010
Select Format Tape Level 1 for Postprint Spacing	0011
Select Level 2	0012
Select Level 3	0013

*This check does not assure that the correct character was printed.

**N = equipment number of the control

TABLE A-1. CONNECT, FUNCTION, AND STATUS CODES (Cont'd)

FUNCTION (Cont'd)	
Select Level 4	0014
Select Level 5	0015
Select Level 6	0016
Select Preprint Spacing	0020
Select Format Tape Level 1 for Preprint Spacing	0021
Select Level 2	0022
Select Level 3	0023
Select Level 4	0024
Select Level 5	0025
Select Level 6	0026
Select Interrupt on Ready and Not Busy	0030
Release Interrupt on Ready and Not Busy	0031
Select Interrupt on End of Operation	0032
Release Interrupt on End of Operation	0033
Select Interrupt on Abnormal End of Operation	0034
Release Interrupt on Abnormal End of Operation	0035
STATUS	
Ready	XXX1
Busy	XXX2
Paper Out	XX1X
Last Line of Form	XX2X
Interrupt on Ready and Not Busy	X2XX
Interrupt on End of Operation	X4XX
Interrupt on Abnormal End of Operation	1XXX
Error*	2XXX
Reserved (by other channel)	4XXX

CONNECT CODE

*Connect Printer (N000)***

This code connects the printer. N must match setting of Equipment Number switch.

*From 3256 Controllers equipped with the error checking option only

**N = equipment number of the control

FUNCTION CODES

Release and Disconnect (0000 and 0040)

These codes which clear the existing connect, channel reserve, and existing interrupt selections are effective only if received from the connected data channel. Either one is recognized and replied to by the printer immediately upon receipt.

Single Space (0001)

This code advances paper one line. It does not clear postprint spacing selections. It is self-clearing.

Double Space (0002)

This code advances paper two lines. It does not clear postprint spacing selections, and it is self-clearing.

Advance to Last Line (0003)

This code advances paper until a hole is detected in format tape level seven. The last line of the form that may be printed should then be in position for printing. This code does not clear postprint spacing selections. It is self-clearing.

Page Eject (0004)

This code advances paper until a hole is detected in format tape level eight. The first line of the new form to be printed should then be in position for printing. This code does not clear postprint spacing selections. It is self-clearing.

Auto Page Eject (0005)

This code, together with the detection of a hole in format tape level seven, advances the paper until a hole is detected in format tape level 8. Format tape level seven indicates the last line of the form that may be printed. Format tape level eight indicates the first line of the new form that may be printed. Auto Page Eject takes precedence over all other postprint spacing selections.

Suppress Space (0006)

This code suppresses the next postprint spacing operation. It is ignored by preprint spacing operations, and it is self-clearing.

Clear Format Selection (0010)

This code clears all format selections as well as Auto Page Eject. It then places the printer in Postprint Automatic Single Space mode.

*Select Format Tape Level X for Postprint Spacing (001X)**

These codes cause automatic advancement of paper following each print operation. Advancement continues until a hole is detected in the selected level. The selections are cleared by Clear Format Selection (0010), Select Preprint Spacing (0020), a Clear Channel instruction, or a Master Clear.

Select Preprint Spacing (0020)

This code clears all postprint spacing selections except Auto Page Eject. It must be used prior to selecting a tape format level for preprint spacing. It does not initiate paper motion.

*Select Format Tape Level X for Preprint Spacing (002X)**

These codes initiate the advancement of paper. Advancement continues until a hole is detected in the selected level. These selections are self-clearing.

Select Interrupt on Ready and Not Busy (0030)

This code causes the control to send an Interrupt signal to the processor when the printer system is Ready and Not Busy (i. e., power is applied, paper is in position, the START switch is lighted, data is not being transmitted to printer memory, and no paper motion is in progress). The control accepts and replies to this code on receipt. Once up, the Interrupt signal remains up until cleared by reselecting the interrupt (0030), selecting release (0031), Clear Channel instruction, or Master Clear.

*X designates any one of the lower 6 tape levels.

Release Interrupt on Ready and Not Busy (0031)

This code clears an Interrupt on Ready and Not Busy selection and the Ready and Not Busy Interrupt signal if it is up. The control accepts and replies to this code on receipt.

Select Interrupt on End of Operation (0032)

This code causes the control to send an Interrupt signal to the processor when a line of data has been printed. (Selected postprint paper motion is also initiated at this time.) The code also causes an Interrupt signal to be returned 14 milliseconds after completion of any preprint paper motion if memory has not been reloaded.

If memory is loaded during preprint paper motion, an Interrupt signal is returned following printing of the data only.

The control accepts and replies to this code on receipt. Once up, the Interrupt signal remains up until cleared by reselecting the interrupt (0032), selecting release (0033), Clear Channel instruction, or Master Clear.

Release Interrupt on End of Operation (0033)

This code clears an Interrupt on End of Operation selection and the End of Operation Interrupt signal if it is up. The control accepts and replies to this code on receipt.

Select Interrupt on Abnormal End of Operation (0034)

This code causes the control to send an Interrupt signal to the processor when an abnormal end of operation occurs. The control accepts and replies to this code on receipt. Once up, the Interrupt signal remains up until cleared by reselecting the interrupt (0034), selecting release (0035), Clear Channel instruction, or Master Clear.

Release Interrupt on Abnormal End of Operation (0035)

This code clears an Interrupt on Abnormal End of Operation selection and the Abnormal End of Operation Interrupt signal if it is up. The control accepts and replies to this code on receipt.

STATUS CODES

Ready (XXX1)

Bit 0 is set when the printer is mechanically Ready.

Busy (XXX2)

Bit 1 is set when data is being printed, paper is being advanced, or memory is being loaded.

Paper Out (XX1X)

Bit 3 is set when there is no paper under the print head.

Last Line of Form (XX2X)

Bit 4 is set when a hole is detected in format tape level seven. This should indicate the last line of the form in position for printing.

Interrupt on Ready and Not Busy (X2XX)

Bit 7 is set if Interrupt on Ready and Not Busy is selected and this condition now exists.

Interrupt on End of Operation (X4XX)

Bit 8 is set if Interrupt on End of Operation is selected and at least one condition specified by the selection exists.

Interrupt on Abnormal End of Operation (1XXX)

Bit 9 is set if Interrupt on Abnormal End of Operation is selected and at least one condition specified by the selection now exists.

*Error (2XXX)**

Bit 10 is set when a print error is detected.

*Reserved (by other channel) (4XXX)***

Bit 11 is set when the printer is reserved by the other channel.

CHARACTER CODES

Table A-2 lists the printer Character Set and the corresponding codes. Both internal and external BCD codes are shown for each character. Normally, the printer prints according to the internal BCD codes. However, if the computer is operating in 1604 mode, *** external BCD codes must be sent to the printer.

Table A-3 shows the printer characters in the order that they appear on the printer drum. To maintain the maximum printing rate, successive characters must fall within 48 consecutive rows on the drum. Table A-3 aids the programmer in selecting a 48-row section of the drum.

TABLE A-2. CHARACTERS ARRANGED BY INTERNAL BCD CODES

Internal BCD	External BCD	Character Printed	Internal BCD	External BCD	Character Printed
00	12	0	13	13	=
01	01	1	14	14	≠
02	02	2	15	15	≤
03	03	3	16	16	%
04	04	4	17	17	[
05	05	5	20	60	+
06	06	6	21	61	A
07	07	7	22	62	B
10	10	8	23	63	C
11	11	9	24	64	D
12	00	: (colon)	25	65	E

*From 3256 Controller equipped with error checking option

**3659 Controller only

***3600/3800 systems only

TABLE A-2. CHARACTERS ARRANGED BY INTERNAL BCD CODES (Cont'd)

Internal BCD	External BCD	Character Printed	Internal BCD	External BCD	Character Printed
26	66	F	53	53	\$
27	67	G	54	54	*
30	70	H	55	55	↑
31	71	I	56	56	↓
32	72	<	57	57	>
33	73	.	60	20	blank
34	74)	61	21	/
35	75	≥	62	22	S
36	76	¬ (NOT)	63	23	T
37	77	;	64	24	U
40	40	-	65	25	V
41	41	J	66	26	W
42	42	K	67	27	X
43	43	L	70	30	Y
44	44	M	71	31	Z
45	45	N	72	32]
46	46	O	73	33	,
47	47	P	74	34	(
50	50	Q	75	35	→
51	51	R	76	36	≡
52	52	∨ (OR)	77	37	^ (AND)

TABLE A-3. CHARACTERS ARRANGED BY CHARACTER ROWS

Character Row	Character Printed	Internal BCD	External BCD	Character Row	Character Printed	Internal BCD	External BCD
1	0	00	12	10	9	11	11
2	1	01	01	11	A	21	61
3	2	02	02	12	B	22	62
4	3	03	03	13	C	23	63
5	4	04	04	14	D	24	64
6	5	05	05	15	E	25	65
7	6	06	06	16	F	26	66
8	7	07	07	17	G	27	67
9	8	10	10	18	H	30	70

TABLE A-3. CHARACTERS ARRANGED BY CHARACTER ROWS (Cont'd)

Character Row	Character Printed	Internal BCD	External BCD	Character Row	Character Printed	Internal BCD	External BCD
19	I	31	71	44	* (asterisk)	54	54
20	J	41	41	45	, (comma)	73	33
21	K	42	42	46	≠ (not equal)	14	14
22	L	43	43	47	\$ (dollar sign)	53	53
23	M	44	44	48	: (colon)	12	00
24	N	45	45	49	≤ (less than or equal)	15	15
25	O	46	46	50	% (per cent)	16	16
26	P	47	47	51	[(open bracket)	17	17
27	Q	50	50	52] (closed bracket)	72	32
28	R	51	51	53	→ (right arrow)	75	35
29	S	62	22	54	≡ (identity)	76	36
30	T	63	23	55	∧ (logical AND)	77	37
31	U	64	24	56	∨ (logical OR)	52	52
32	V	65	25	57	¬ (logical NOT)	36	76
33	W	66	26	58	↑ (arrow up)	55	55
34	X	67	27	59	↓ (arrow down)	56	56
35	Y	70	30	60	> (greater than)	57	57
36	Z	71	31	61	< (less than)	32	72
37	. (period)	33	73	62	≥ (greater than or equal)	35	75
38	- (minus)	40	40	63	; (semi-colon)	37	77
39	+ (plus)	20	60	64	blank (no character)	60	20
40	= (equals)	13	13				
41	((open parenthesis)	74	34				
42) (closed parenthesis)	34	74				
43	/ (slash)	61	21				

SWITCHES AND INDICATORS

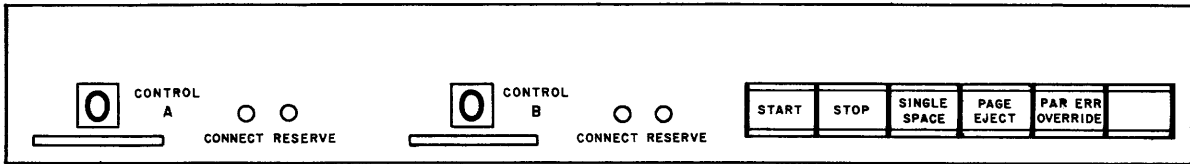

Figure A-2. 3659 Controller Switch and Indicator Panel

EQUIPMENT NUMBER SWITCH

An eight-position Equipment Number switch is associated with each control. The setting of this switch (0-7) designates the control and corresponds to the N portion of the Connect code. It also determines the number of the interrupt transmission line used by the equipment.

A white indicator in this switch is lighted whenever power is applied to the control. A red indicator in this switch is lighted when a transmission parity error is detected. The Parity Error indicator is turned off by a Clear Channel instruction, Master Clear, or by pressing the STOP and START switches in sequence.

RESERVE INDICATORS

The RESERVE indicator associated with a control is lighted when the control is reserved by its associated data channel.

CONNECT INDICATORS

The CONNECT indicator associated with a control is lighted when the control is connected to its associated data channel.

START SWITCH

This momentary-contact switch puts the printer under computer control. A white indicator in the switch lights when the printer is Ready.

This switch may also be used to force the completion of a page if the printer has stopped due to a low paper supply. One line is printed each time the switch is pressed. This action may be repeated until a hole is detected in format tape level eight. The START switch is of no further value until the paper supply is replenished. Then it causes printing to continue without a loss of information.

STOP SWITCH

This momentary-contact switch causes the controller to become Not Ready. If data is being transferred to printer memory when the switch is pressed, the loading continues to completion. No other data is accepted by the control while the switch is lighted.

CAUTION

Turn off the printer before turning off the 3659/3256 Controller.

SINGLE SPACE SWITCH

This switch advances the paper one line.

PAGE EJECT SWITCH

This switch advances the paper until a hole is detected in format tape level eight. The first line of the new form to be printed on should then be in position for printing.

PARITY ERROR OVERRIDE SWITCH*

This alternate-action switch provides the option of printing or stopping on detection of a data transmission parity error. If the switch is not lighted, operation stops when printer memory is loaded. If it is lighted, printing continues without regard to parity errors.

ERROR OVERRIDE SWITCH

This alternate-action switch provides the option of printing or stopping on detection of either a parity error or a print error. If the switch is not lighted and either type of error is detected, operation stops when printer memory is loaded. If it is lighted, printing continues without regard to errors.

*This switch is replaced by an ERROR OVERRIDE switch on 3256 Controllers modified for print error checking.

OPERATION AND PROGRAMMING

OPERATION

Format Tape Preparation

The eight-level format tape is of punched Mylar, approximately 13 inches long, joined in a continuous loop. This tape contains a number of frames equal to, or a multiple of, the number of lines on the printed page. If short forms are to be printed, duplicate hole patterns for several forms can be punched in the tape. Because of the physical characteristics of the reader mechanism, the tape must have a minimum length of 6-1/2 inches. During any spacing operation, the format tape is advanced one frame each time the paper advances one line.

As shown in Figure A-3, the format tape includes a row of feed holes which engage cogs on a metal drum and drive the tape. Tape levels one through eight are monitored by a photocell assembly, and paper is stopped when the selected level is sensed. Levels are selected by issuing the desired function codes. Selecting any level one through six for postprint spacing provides a means of extending the automatic single space feature to include more than one line. For example, if function code 0014 is selected, paper starts moving after each line is printed and continues to move until the photocells sense a hole in level four of the tape. By using the preprint function codes, paper may be moved before printing. Preprint spacing operations are also controlled by holes in tape levels one through six.

Level eight must always contain only one hole punched in the first frame. This level may be selected by function code 0004 or by pressing the PAGE EJECT switch on the control panel. When selected, level eight moves paper to the top of the form.

Level seven must also contain only one hole which corresponds to the last line of print. This hole may be punched in any frame according to the desired format. In the example shown, the hole in level seven is in frame 62, consequently, the last line was printed on line 62 of the paper.

In the example (Figure A-3), level three contains holes in every third frame, and level two contains holes in every second. This is a convenient arrangement because the sample form contains a number of triple spaces and double spaces. Selecting level three allows printing in lines 7, 10, and 13, double-spacing the main heading and triple-spacing to the column headings and the first tabulated figures.

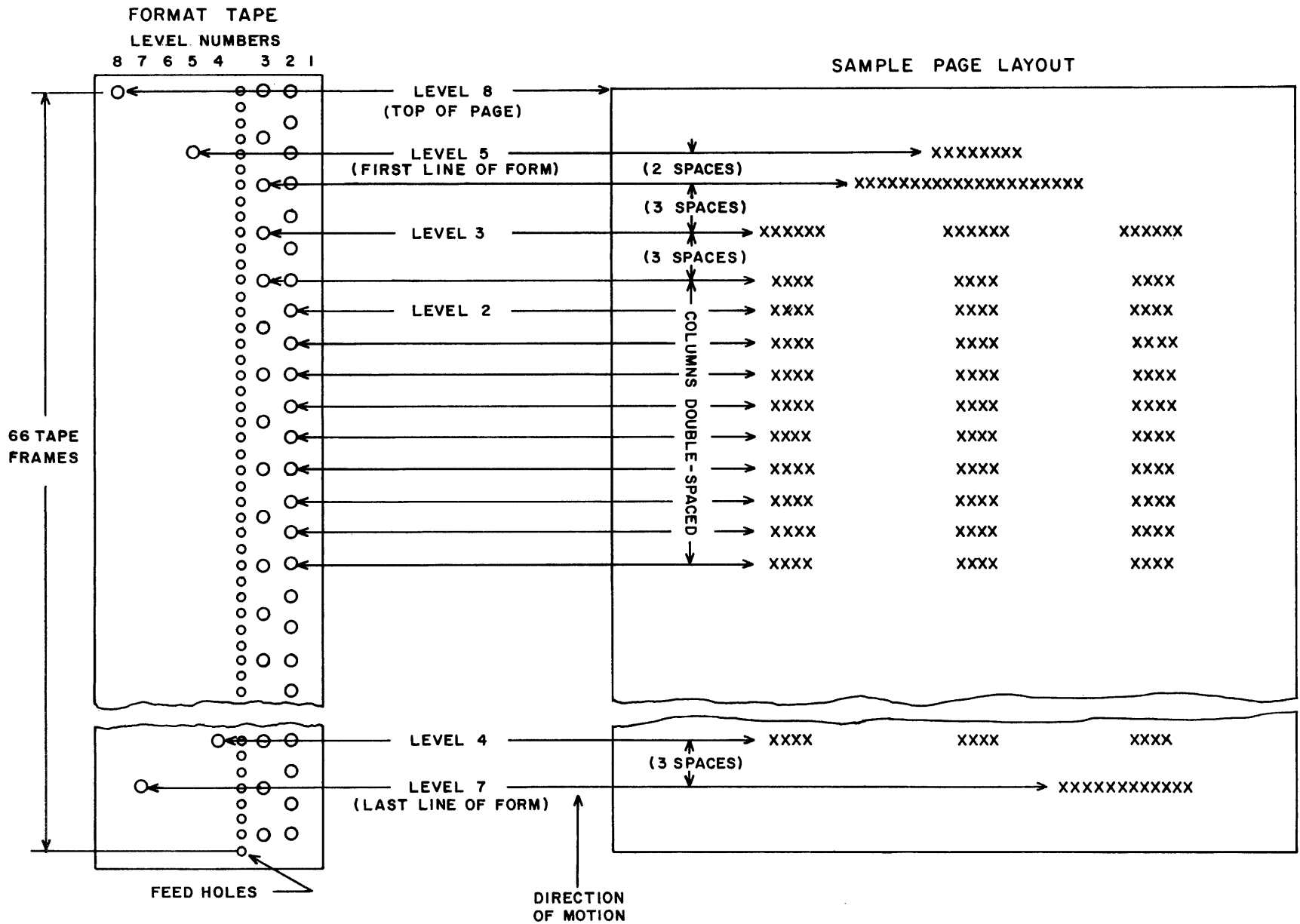

Figure A-3. Spacing Example

Referring again to the sample page, note that a line is to be printed eight lines from the bottom on the page. To do this, punch a hole in frame 59 of level four. Also, the double space function used in the preceding lines of print must be cleared and level four selected.

The last line to be printed is three spaces below the preceding line and, as mentioned above, is controlled by level seven of the tape.

After the last line has been printed, level eight must be selected to move paper to the top of the form.

Clearing the Controller

Prior to the initial use of the printer, the system should be cleared. There are four possible ways of clearing the controller:

1) Clear Channel (100 microseconds)

This instruction:

- a) Clears all activity in the data channel.
- b) Clears any connection the channel may have with the printer.
- c) Releases any reservation the channel may have for the printer.
- d) Performs a Master Clear on write and function logic. No status signals are available to the data channel after executing this instruction.

2) Release and Disconnect (0000 and 0040)

This function code clears any connection and reservation the channel may have with the printer. The printer must be connected to the channel when this function code is issued. It does not clear reservations made by the other channel.

3) Power On Master Clear

When power is applied to the controller, printer connections and reservations are cleared. Logic is also cleared. No status signals are available to the data channel after power is applied.

4) External Master Clear

A Master Clear disconnects the controller, clears the channel reservation, and clears all logic. No status signals are available from the controller after a Master Clear.

PROGRAMMING CONSIDERATIONS

Function Codes - Release and Disconnect (0000 and 0040)

Should either of these two codes be received by the control while a line is being printed, the printing operation continues to completion. This is true even if the other channel* connects and issues either a Clear Channel instruction or a Master Clear during this time interval. Since these codes clear existing interrupt selections, the releasing channel does not receive new Interrupt signals. However, should the newly connected channel request interrupts, it receives them when the appropriate conditions occur.

Printing Rate (501 Printer)

A 1,000-line per minute printing rate (up to 136 characters per line) can be maintained on the 501 Printer if:

- 1) The character set is confined to any 48 consecutive rows on the printer drum (see Table A-3).
- 2) Single spacing is maintained between lines.
- 3) The data channel begins to load a new line of data into the buffer memory within 11 milliseconds after the End of Operation interrupt is generated at the end of the previous line.

The buffer memory can be fully loaded in 3.5 milliseconds.

Table A-3 shows the order of characters on the printer drum and aids the programmer in selecting a 48-row character set. If all 64 characters are used, the printing rate may be reduced to 800 lines per minute with single spacing.

*3659 Controller only

SECTION B

**3692-A PROGRAM CONTROLLED
INPUT/OUTPUT TYPEWRITER**

CONTENTS

Functional Description	B-1	Codes	B-7
Disassembly (Write Operation)	B-2	Connect Code	B-8
Read	B-2	Function Codes	B-8
Connect	B-3	Status Codes	B-9
Function	B-3	Character Codes	B-10
Interrupts	B-4	Switches and Indicators	B-11
Status	B-5	Panel Switches and Indicators	B-11
Parity Checking	B-5	Typewriter Controls	B-13
Transmission Parity Checking	B-5	Operation and Programming	B-15
Type Parity Checking	B-7	Clearing the Typewriter	B-15

FIGURES

B-1 Typical Configurations	B-1	B-3 Typewriter Controls	B-13
B-2 3692 Typewriter Switch and Indicator Panel	B-11		

TABLES

B-1 Connect, Interrupt, and Status Codes	B-8	B-2 Typewriter Codes	B-10
--	-----	----------------------	------



3692 PROGRAM CONTROLLED INPUT/OUTPUT TYPEWRITER

3692-A PROGRAM CONTROLLED INPUT/OUTPUT TYPEWRITER

The CONTROL DATA* 3692 Program Controlled Input/Output Typewriter permits communication between an operator and any 3000 Series processor via a 3000 Series data channel. It also may be used to communicate with a 160/160-A Computer via a 3000 Series data channel and a CONTROL DATA 3681 Data Channel Converter. (See Figure B-1.) When used as an input device for the 160/160-A Computer, an Input to A instruction must be used.

This section describes the disassembly of data received from the data channel. It also describes the Connect, Function, and Status codes and provides pertinent programming information.

FUNCTIONAL DESCRIPTION

The 3692 Typewriter consists of an IBM 731 Selectric Input/Output Writer and controller mounted in a single cabinet.

The IBM 731 Selectric Input/Output Writer is basically an IBM Series 72 Selectric Typewriter adapted for computer input/output use. Type-out rate is approximately 15 characters per second.

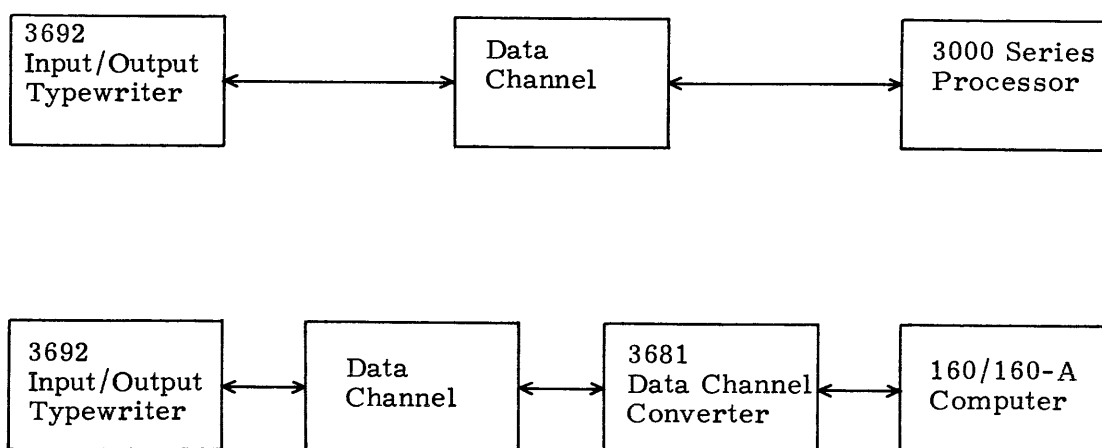

Figure B-1. Typical Configurations

* Registered trademark of Control Data Corporation

DISASSEMBLY (WRITE OPERATION)

During Write operations, the controller receives data from the data channel in 12-bit bytes (i. e., 12 bits of data are received simultaneously on 12 data lines). The typewriter, however, can handle only one 6-bit character at a time. The controller disassembles each byte into two characters. The character comprised of the upper 6 bits is transmitted to the typewriter first, followed by the lower 6 bits.

Each 6-bit character causes the typewriter to type a unique character or to perform a typewriter function, such as lower case shift. Table B-2 lists the typewriter codes.

Disassembly is automatically suppressed when a 3100/3200 Character Output instruction (OUTC or OTAC) is executed. In this case, the typewriter accepts only the lower 6 bits of each byte.

READ

During Read (Input) operations, the data channel requests information from the typewriter. Each time the operator types a character, the typewriter sends a 6-bit Character code to the data channel. The manner in which each character is entered into a storage word depends on storage word size (24 or 48 bit) and, in 3100 and 3200 systems, the type of Input operation (Character-Addressed or Word-Addressed).

In 3400, 3600, and 3800 systems, the data channel forms 48-bit storage words from groups of 4 sequential input bytes. During Read operations, the typewriter places each 6-bit character into the lower 6 bits of a separate storage word. The upper 42 bits of each word are filled with zeros.

In 3100 and 3200 systems, storage word size is 24 bits. A Read (Input) operation can be either word-addressed or character-addressed.

During word-addressed Input operations, the typewriter places each 6-bit character into the lower 6 bits of a separate storage word. The upper 18 bits of each word are filled with zeros.

During character-addressed Input operations, the data channel requests either a series of 6-bit characters or a series of 12-bit bytes. If 6-bit characters are requested, the typewriter returns a 6-bit character for each request. If 12-bit bytes are requested, the typewriter places a 6-bit character into the lower portion of each byte. The upper 6 bits of each byte are filled with zeros.

CONNECT

The typewriter must be connected to the data channel before it can respond to either a Select/Function instruction or a Read or Write instruction. The connection is accomplished by the Connect instruction; the Connect code (N000) is the lower 12 bits of this instruction. Each device attached to the data channel examines every Connect code transmitted from the data channel. The typewriter connects and returns a Reply* signal to the data channel if:

- 1) The N portion of the Connect code matches the setting (0 - 7) of the Equipment Number switch on the typewriter.
- 2) A transmission parity error does not occur.

If the N portion of the Connect code does not match the setting of the Equipment Number switch, a Reply is not returned to the channel from this equipment. Equipment status is not made available to the channel. If the controller is already connected, it automatically disconnects. If a Reply is not returned to the data channel from any of its attached equipments within 100 microseconds, the central processor generates an Internal Reject.

If a parity error is detected in a Connect code, the typewriter does not connect*** and a Reply is not returned to the data channel. Instead, the Transmission Parity Error indicator lights. Parity error conditions must be cleared by either a Clear Channel instruction or a Master Clear prior to a new connect attempt.

FUNCTION

Function codes are used to prepare a connected control and/or unit for an Input/Output operation. (They have no effect on unconnected controls or units). They comprise the lower 12 bits of a Select/Function*** instruction and are transmitted to the control on the 12 data lines. A complete list of Function codes is given in Table B-1. A detailed description of each code follows the table.

A control examines only one code at a time. First, it checks for parity errors. If none are found, it returns a Reply if the requested function can be performed**** or a Reject if it cannot be performed.

* A Reply signal tells the central processor to process the next instruction.

** If the device is connected, it automatically disconnects.

*** Select in 3100/3200 systems, Function in 3400/3600/3800 systems

**** Certain do-nothing function codes cause a Reply to be returned. However, in these cases, no action follows.

If a parity error is detected, the requested function is not performed, a Parity Error signal is returned to the data channel, and a Transmission Parity Error indicator lights. Since neither a Reply nor a Reject is returned to the data channel, the central processor generates an Internal Reject after a wait of 100 microseconds.

These parity error indications must be cleared by either a Clear Channel instruction or a Master Clear. The equipment must then be reconnected before a new function code is examined by the controller.

INTERRUPTS

Interrupts provide a means for attaining optimum utilization of a system's capabilities. Basically, the system interrupts (halts) the main program and initiates an interrupt processing program* when an Interrupt signal is detected by the processor.

The typewriter can be programmed to send an Interrupt signal to the processor when any one of the conditions specified by the three interrupts** materializes.

A Select Interrupt code permits the controller to consider as a group*** several of the operating conditions which may occur in an attached unit. If a specific interrupt has been selected and if at least one of the conditions specified by it occurs in the connected unit, the controller sends an Interrupt signal to the processor. If the interrupt system in the processor has been set to recognize the interrupt, the main program is interrupted and control is transferred to a specific program address. Status sensing and followup operations may follow. If desired, control may be returned to the main program by an appropriate Jump instruction located at the close of the interrupt processing program.

If the processor's interrupt system has not been enabled, it is still possible to sense for these conditions using Sense Status and Copy Status instructions.

Regardless of which of the above actions is followed the Interrupt signal remains up until cleared by reselecting the interrupt, selecting release, or master clearing the system. The Interrupt signal is transmitted on the equipment's interrupt line via the data channel currently connected to or reserving the equipment or, in the case of a single-channel controller, via the physically connected data channel whether or not the channel is currently servicing the equipment.

* See the system reference manual for the addresses pertinent to interrupt processing.

** See explanation of function codes following Table B-1 for a list of these conditions.

*** See description of function codes following Table B-1 for a breakdown of the three possible groups.

The eight-position (0-7) Equipment Number switch determines the number of the line on which the Interrupt signal is transmitted on. For example, if the Equipment Number switch is set at 5, all Interrupt signals coming from the typewriter are transmitted on interrupt line 5. Since each equipment attached to a data channel has a unique equipment number, each uses a different interrupt line. A Channel Product Register Jump Instruction* or a Copy Status Instruction** can identify the equipment sending the Interrupt signal by inspecting the interrupt lines.

STATUS

Status codes permit the monitoring of several control/unit operating conditions. These codes are made available to the data channel over 12 status lines following a connect or a rejected connect attempt. Sense Status and Copy Status instructions make these codes available to the central processor.

See Table B-1 for a complete list of these codes. If two or more conditions exist simultaneously, the Status Response code is the sum of the individual codes. A detailed description of each code follows the table.

PARITY CHECKING

Two types of parity checks verify the integrity of data processed by the typewriter. A transmission parity check is performed on data and codes exchanged between the typewriter and the data channel. A type parity check is conducted on data sent from the typewriter controller to the selectric input/output writer.

Transmission Parity Checking

Connect codes, function codes, and data are transmitted between the data channel and the controller in odd parity (i. e., the number of "1" bits transmitted must be odd). If the number of "1" bits in a data byte is even, a "1" is transmitted on the parity line to make the number of "1" bits odd.*** If the number of "1" bits in the data byte is odd, the "1" is not transmitted on the parity line.

A transmission parity error exists if the total number of "1" bits transmitted on the 12 data lines plus the parity line is even, indicating that a bit has been lost or picked up.

* 3600/3800 systems

** 3100/3200/3400 systems

*** Do not confuse this line with the parity error line.

Parity Error in a Connect Code: If a parity error is detected in a Connect code, the device does not connect* and a Reply is not returned to the data channel. Instead, a red indicator on all equipments detecting the error lights. These parity error conditions must be cleared by either a Clear Channel instruction or a Master Clear prior to a new connect attempt.

Parity Error in a Function Code: If a parity error is detected, the requested function is not performed, a Parity Error signal is returned to the data channel, and the Transmission Parity Error indicator lights. Since neither a Reject nor a Reply is returned to the data channel, the central processor generates an Internal Reject after a wait of 100 microseconds. These parity error indications must be cleared by a Clear Channel instruction or a Master Clear.** The equipment must then be reconnected before a new function code can be examined by the controller.

Parity Error in Output Data: If a transmission parity error is detected by the controller during a Write operation, the typewriter Transmission Parity Error indicator lights and sends both a Reply and a Parity Error signal to the data channel. The faulty character is typed. All operations continue*** unless appropriate programming steps have been taken to sense the Parity Error signal and rewrite the data. These parity error indications must be cleared by either a Clear Channel instruction or a Master Clear. The typewriter must then be reconnected and the appropriate functions reselected prior to the new output.

Parity Errors in Input Data: Transmission parity errors may be detected by the data channel on data received from the equipment. If a parity error is detected, a parity error bit in the data channel is set and a Parity Error indicator on either the data channel or console lights. The faulty data is entered into either core storage or the A register. All operations continue**** unless appropriate programming steps have been taken to sense for the set bit and reread the data. These parity error indications may

*If the device is connected, it automatically disconnects.

**Though operations may continue normally, the validity of a new function code and/or data prior to a Master Clear or Clear Channel instruction is questionable.

***The validity of the data received from this point until a Clear Channel instruction or Master Clear is questionable.

****The validity of the data received from this point until the indicators are cleared is questionable.

be cleared by a Clear Channel instruction or a Master Clear issued by any 3000 Series system and by a new Read or Write from a 3100/3200 system. Following a Clear Channel instruction or a Master Clear, the equipment must be reconnected and the appropriate functions reselected prior to a new input.

Input/Output Parity Error Bit in the Data Channel: The Input/Output parity error bit is set whenever a transmission parity error is detected. If the error is detected by the external equipment, the bit is set by the Parity Error signal.

In 3400/3600/3800 systems, an Interrupt signal is generated when this bit sets. If the interrupt system has not been set to detect the setting of this bit, the bit may be sensed to detect parity error conditions.

In 3100/3200 systems, the bit must be sensed if transmission parity error conditions are to be detected by the central processor.

Refer to the appropriate system reference manual for more information on the input/output parity error bit.

Type Parity Checking

The typewriter controller checks to see that the selectric input/output writer responds correctly to each Character code. If an error occurs, the typewriter:

- 1) Sends a "1" on the type parity error status line.
- 2) Sends an Interrupt signal to the processor if Interrupt on Abnormal End of Operation is selected.

CODES

Tables B-1 and B-2 list all codes applicable to the 3692 Typewriter. The Connect, Function, and Status codes are explained in the section following Table B-1. In all discussion of codes, bit 0 is in the rightmost position.

TABLE B-1. CONNECT, INTERRUPT, AND STATUS CODES

CONNECT	
Connect Typewriter	N000*
FUNCTION	
Select Interrupt on Abnormal End of Operation	0001
Release Interrupt on Abnormal End of Operation	0002
Clear Interrupt	0004
Select Interrupt on Manual Switch	0010
Release Interrupt on Manual Switch	0020
STATUS	
Ready	XXX1
Busy	XXX2
Upper Case Mode	XXX4
End of Line	XX4X
Type Parity Error	2XXX

CONNECT CODE

Connect Typewriter (N000)

This code connects the typewriter. The N portion of the code must match the setting of the Equipment Number switch on the typewriter.

FUNCTION CODES

Select Interrupt on Abnormal End of Operation (0001)

This code causes the controller to send an Interrupt signal to the processor if a type parity error is detected or if the type head reaches the right margin stop.

Release Interrupt on Abnormal End of Operation (0002)

This code clears the Interrupt on Abnormal End of Operation selection. It does not clear the Interrupt signal.

* N = the equipment number of the controller

Clear Interrupt (0004)

This code clears the Interrupt signal.

Select Manual Interrupt (0010)

This code enables the controller to send an Interrupt signal to the processor when the INTERRUPT switch is pressed.

Release Manual Interrupt (0020)

This code disables manual interrupt. It does not clear the Interrupt signal.

STATUS CODES

Ready (XXX1)—Bit 0

This signal indicates power is applied to 731 Selectric Input/Output Writer.

Busy (XXX2)—Bit 1

This signal indicates a Read, Write, or Function operation is being performed.

Upper Case Mode (XXX4)—Bit 2

This signal indicates the typewriter is in Upper Case mode.

End of Line (XX4X)—Bit 5

This signal indicates the type head is at the right margin stop. If a carrier return is not performed, the End of Line signal drops at a point seven or eight spaces beyond the right margin stop. If a carrier return is not executed within these seven or eight spaces, the carrier may continue to the physical end of the line and continue typing in that one location. An automatic carrier return does not occur. The End of Line condition also causes Abnormal End of Operation interrupt if selected.

Connect Coupler (N000)

This signal indicates that a parity error occurred between the typewriter controller and the 731 Selectric Input/Output Writer. The signal remains up until a carrier return is performed. A type parity error is also an Abnormal End of Operation interrupt condition.

CHARACTER CODES

Table B-2 lists the Character codes that apply to the typewriter during Read and Write operations. Any other codes cause the typewriter to print random characters.

TABLE B-2. TYPEWRITER CODES

Lower Case	Code	Upper Case	Lower Case	Code	Upper Case
A	12	A			
B	01	B	0 (zero)	43)
C	11	C	1	77	±
D	55	D	2	37	
E	51	E	3	33	#
F	30	F	4	47	\$
G	74	G	5	57	%
H	45	H	6	13	
I	16	I	7	53	& (and)
J	70	J	8	17	* (asterisk)
K	15	K	9	07	(
L	41	L	!	76	o (degree)
M	72	M	.	32	.
N	31	N	'	52	"
O	42	O	;	50	:
P	54	P	,	14	,
Q	10	Q	/	44	?
R	56	R	=	34	+
S	46	S	- (dash)	04	_ (underline)
T	75	T	Space	60	Space
U	35	U	Backspace	61	Backspace
V	36	V	Tab	62	Tab
W	02	W	C. R.	63	C. R.
X	71	X	U. C.	64	U. C.
Y	40	Y	L. C.	66	L. C.
Z	73	Z			

SWITCHES AND INDICATORS

PANEL SWITCHES AND INDICATORS

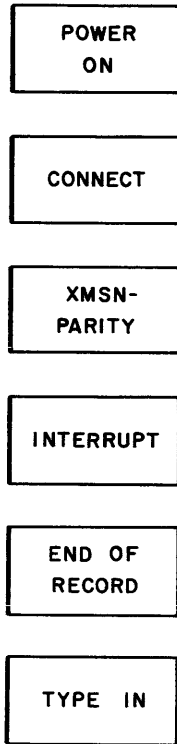

Figure B-2. 3692 Typewriter Switch and Indicator Panel

Equipment Number Switch*

The Equipment Number switch is an eight-position switch. Its setting (0-7) designates the typewriter and corresponds to the N portion of the Connect code. It also determines the number of the interrupt transmission line that the equipment uses.

POWER ON Switch

This alternate-action switch applies ac power to the 3692 Typewriter.

* Located on the logic panel which is mounted on the back side of the 3692 Typewriter console

CONNECT Indicator

This indicator lights when the typewriter is connected to a data channel for Input/Output operations.

XMSN-PARITY (Transmission Parity Error) Indicator

This indicator lights when a parity error occurs during a Connect, Function, or Write operation.

INTERRUPT Switch (Manual Interrupt)

This momentary-action switch sends an Interrupt signal to the processor if enabled by the Manual Interrupt function code. The Interrupt signal is transmitted whether or not the typewriter is connected to the data channel.

END OF RECORD Switch

This momentary-action switch sends an End of Record signal to the data channel. It is active when the typewriter is connected to the data channel.

TYPE IN Indicator

This indicator lights whenever the data channel requests data. The operator may type when this signal is received.

ON/OFF Switch

This switch applies power to the 731 Selectric Input/Output Writer motor. It is located on the typewriter proper.

TYPEWRITER CONTROLS

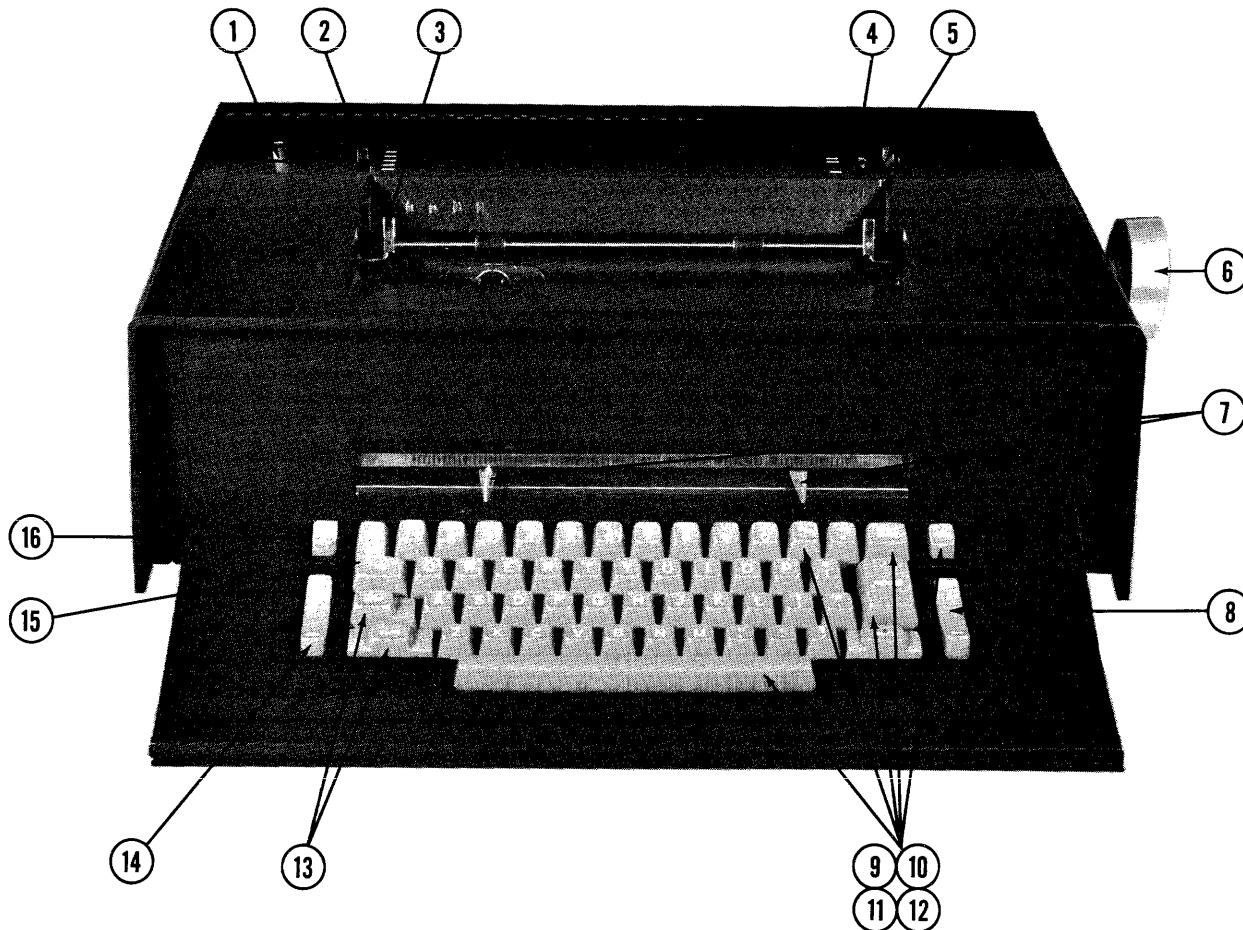

Figure B-3. Typewriter Controls

INDEX TO FIGURE B-3

1. Platten variable lever	9. Index key
2. Multiple copy control lever	10. Backspace
3. Paper bail	11. Carrier return
4. Line space lever	12. Space bar
5. Paper release lever	13. Shift key and shift lock
6. Platten knob	14. Tab control
7. Right and left margin controls	15. Tab key
8. Motor control	16. Margin release key

Platten Variable Lever

Moving this lever to the left permits the platten to be rotated freely by the platten knob(6).

Multiple Copy Control Lever

Moving this lever compensates for additional copies or for the weight of the paper.

Paper Bail

Move the bail forward to insert paper. Move it back to hold the paper against the platten.

Line Space Lever

Single (-) or double (=) spacing may be selected.

Paper Release Lever

Move this lever forward to position or remove paper.

Platten Knob

Rotates the platten.

Right and Left Margin Controls

These controls determine the margins. Depress and slide each control to the desired location.

Motor Control

This switch activates the typewriter.

Index Key

This key expedites vertical paper motion. Paper moves as long as the key is depressed. Use it to insert paper.

Backspace

This key moves the carrier toward the left margin. Motion continues as long as the key is depressed.

Carrier Return

This key returns the carrier to the left margin and spaces the paper. Motion continues as long as the key is depressed.

Space Bar

This bar advances the carrier. It is not limited by the right margin stop. Motion continues as long as the key is depressed.

Shift Key and Shift Lock

These keys permit selection of upper and lower case characters.

Tab Control

Depressing the SET side sets the tab. Depressing the CLR side clears it.

Tab Key

This key moves the carrier to a tabular stop. It is not limited by the right margin stop.

Margin Release Key

This key releases both right and left margins.

OPERATION AND PROGRAMMING

CLEARING THE TYPEWRITER

Prior to the initial use, the system should be cleared. There are three possible ways of clearing the typewriter:

1) **Clear Channel***

This instruction:

- a) Clears all activity in the data channel.
- b) Performs a Master Clear on the typewriter read, write, and function logic. No status signals are available to the data channel after executing this instruction.

* See the individual processor instructions.

2) Power On Master Clear

When power is applied to the typewriter, the logic is cleared. No status signals are available to the data channel after power is applied.

3) External Master Clear

This clears the logic in all controls. No status signals are available to the data channel after executing this operation.

SECTION C

3293-A INCREMENTAL PLOTTER

CONTENTS

Functional Description	C-1	Connect Code	C-8
System Relationship	C-1	Function Codes	C-9
Calcomp Recorders	C-1	Status Codes	C-10
Write Operations	C-2	Plotter Movement Codes	C-11
Disassembly Mode	C-2	Switches and Indicators	C-13
Character Mode	C-3	Controller Switches and Indicators	C-13
Connect	C-3	Calcomp Plotter Switches and Indicators	C-13
Function	C-4	Operation and Programming	C-15
Interrupts	C-5	Plotter Preparation	C-15
Status	C-6	Plotter Size	C-15
Parity Checking (Transmission)	C-6		
Codes	C-7		

FIGURES

C-1 Typical Configuration	C-1	C-3 3293 Controller Panel	C-13
C-2 Plotter Steps	C-12	C-4 Calcomp Switches and Indicators	C-14

TABLES

C-1 Plotter Specifications	C-2	C-3 Plotter Movement Codes	C-12
C-2 Connect, Function, and Status Codes	C-8		



3293 INCREMENTAL PLOTTER

3293-A INCREMENTAL PLOTTER

The CONTROL DATA* 3293 Incremental Plotter Controller adapts the Calcomp Digital Incremental Plotter Models 563, 564, 565, and 566 to a standard 3000 Series data channel. Thus, it may be used in any 3000 Series system. (See Figure C-1.)

This section describes the disassembly of data received from the data channel. It also describes the Connect, Function, and Status codes and provides pertinent programming information.

Throughout this section, the term "plotter" refers to the system consisting of the plotter controller and a basic Calcomp plotter.

FUNCTIONAL DESCRIPTION

SYSTEM RELATIONSHIP

The plotter is a single-channel device that can be attached to only one data channel. It is assigned an equipment number (0-7) to distinguish it from other equipments attached to the data channel.

CALCOMP RECORDERS

The Calcomp recorders (plotters) are high-speed, two-axis recorders for plotting one variable against another. The plotters consist of a ballpoint pen mounted on a carriage and a bidirectional recording drum. Movement codes from the controller direct pen carriage movement and drum rotation as well as movement of the pen against or away

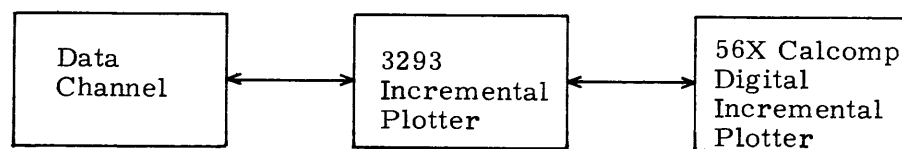

Figure C-1. Typical Configuration

*Registered trademark of Control Data Corporation

from the recording surface. The pen carriage moves in the X axis (horizontally) and the drum moves in the Y axis (vertically). See Table C-1 for plotter specifications. Additional information concerning the plotter may be found in Calcomp Digital Recorder Instruction Manual.

WRITE OPERATIONS

During Write operations, the plotter operates in response to 6-bit Plotter Movement codes sent from the data channel. The plotter normally operates in Disassembly mode; however, Character mode can be selected by the Character Mode function code.

Disassembly Mode

The plotter receives data from the data channel in 12-bit bytes. Each byte contains two 6-bit Plotter Movement codes which specify plotter motion. Various Plotter codes (Table C-3) specify horizontal or vertical plotter movements, 45-degree movements, or raising or lowering of the pen. The Calcomp plotter accepts only one 6-bit character at a time. Therefore, the controller disassembles each byte into two 6-bit codes. The upper code (upper 6 bits) is plotted first, followed by the lower code.

Disassembly is automatically suppressed when a 3100/3200 Character Output instruction (OUTC or OTAC) is executed. In this case, the controller sends only the lower 6 bits of the data byte to the plotter. The upper 6 bits of the byte are ignored. The OUTC and OTAC instructions cause the data channel to place information only in the lower 6 bits of each byte. Thus, no data is lost when the upper 6-bit portion of a byte is ignored.

TABLE C-1. PLOTTER SPECIFICATIONS

	Model 563	Model 564	Model 565	Model 566
Chart Width	31 inches	31 inches	12 inches	12 inches
Plotting Width	29-1/2 inches	29-1/2 inches	11 inches	11 inches
Chart Length	120 feet	120 feet	120 feet	120 feet
Step Size	0.01 inch	0.005 inch	0.01 inch	0.005 inch
Steps/Min	12,000/min	18,000/min	18,000/min	18,000/min
Pen Movement/Min	600/min	600/min		600/min

Character Mode

Character mode is selected or released by two function codes (see Table C-2). When the plotter system is in Character mode, the manner in which it operates depends on storage word size (24 or 48 bit) and, in 3100 and 3200 systems, the type of Output (Write) operation (Word-Addressed or Character-Addressed).

In 3400, 3600, and 3800 systems, storage word size is 48 bits. The data channel disassembles each word into 4 12-bit bytes. During Character mode operations, the plotter accepts only the lower 6 bits of each storage word, that is, the lower 6 bits of every fourth byte. The upper 42 bits of each word are ignored.

In 3100 and 3200 systems, storage word size is 24 bits. An Output (Write) operation can be either word-addressed or character-addressed.

During Word-Addressed Output operations, the data channel disassembles each 24-bit word into 2 12-bit bytes. In Character Mode, the plotter accepts the lower 6 bits of each storage word, that is, the lower 6 bits of every second byte. The upper 18 bits of each word are ignored.

If the plotter is in Character mode during Character-Addressed Output operations, it accepts only the lower 6 bits of each byte. Any information in the upper 6 bits is ignored.

CONNECT

The plotter must be connected to the data channel before it can respond to either a Select/Function instruction or a Write instruction. The connection is accomplished by the Connect instruction; the Connect code (N000) is the lower 12 bits of this instruction. The control examines every Connect code transmitted from the data channel. It connects and returns a Reply* to the data channel if:

- 1) The N portion of the Connect code matches the setting of the Equipment Number switch.
- 2) A transmission parity error is not detected.

*A Reply signal tells the central processor to process the next instruction.

If the N portion of the Connect code does not match the setting of the Equipment Number switch, the plotter returns neither a Reject nor a Reply to the data channel. Equipment status is not made available to the channel. If the controller is already connected, it automatically disconnects. If neither a Reply nor a Reject is returned to the data channel from any of its attached equipments within 100 microseconds, the central processor generates an Internal Reject. A Reject signal causes the central processor to read the next instruction from the reset jump address contained in the Connect instruction.

If a parity error is detected in a Connect code, the plotter does not connect* and neither a Reject nor a Reply is returned to the data channel. Instead, Parity Error indicators light on all input/output devices attached to the data channel. These parity error conditions must be cleared by either a Clear Channel instruction or a Master Clear prior to a new connect attempt.

FUNCTION

Function codes are used to prepare the plotter system for an Input/Output operation. The plotter responds to function codes only when connected. They comprise the lower 12 bits of a Select/Function instruction and are transmitted to the plotter systems on the 12 data lines. See Table C-2 for a complete list of these codes. A detailed description of each code follows the table.

The controller examines only one code at a time. First, it checks for parity errors. If none are found, it returns a Reply if the requested function can be performed** or a Reject if it cannot be performed.

If a parity error is detected, the function is not performed, a Parity Error signal is returned to the data channel, and the Parity Error indicator lights. Since neither a Reply nor a Reject is returned to the data channel, the central processor generates an Internal Reject after a wait of 100 microseconds.

These parity error indications must be cleared by either a Clear Channel instruction or a Master Clear. The plotter must then be reconnected before a new function code is examined by the controller.

*If the device is connected, it automatically disconnects.

**All illegal Function codes cause a Reply to be returned. However, in these cases, no action follows.

INTERRUPTS

Interrupts provide a means for attaining optimum utilization of a system's capabilities. Basically, the system interrupts (halts) the main program and initiates an interrupt processing program* when an Interrupt signal is detected by the processor.

The plotter system can be programmed to send an Interrupt signal to the processor when any one of the conditions specified by the three interrupts** materializes.

A Select Interrupt code permits the controller to consider as a group*** several of the operating conditions which may occur in an attached unit. If a specific interrupt has been selected and if at least one of the conditions specified by it occurs in the connected unit, the controller sends an Interrupt signal to the processor. If the interrupt system in the processor has been set to recognize the interrupt, the main program is interrupted and control is transferred to a specific program address. Status sensing and followup operations may follow. If desired, control may be returned to the main program by a Jump instruction located at the close of the interrupt processing program.

If the processor's interrupt system has not been enabled, it is still possible to sense for these conditions via Sense Status and Copy Status instructions.

Regardless of which of the above actions is followed, the Interrupt signal remains up until cleared by reselecting the interrupt, selecting release, or master clearing the system. The Interrupt signal is transmitted on the equipment's interrupt line via the data channel currently connected to or reserving the equipment.

The plotter transmits the Interrupt signal to the data channel on one of eight interrupt lines. The setting of the eight-position Equipment Number switch on the controller determines which line is used. For example, if the switch is set to 4, the Interrupt signal goes out on line 4. Since each input/output device attached to the data channel is assigned a unique equipment number, each device uses a separate interrupt line. A Channel Product Register Jump instruction**** or Copy Status instruction***** can identify which of several equipments attached to a data channel sends an interrupt by inspecting the eight interrupt lines.

*See the system reference manual for the addresses pertinent to the interrupt processing.

**See section on function codes following Table C-1 for a list of these conditions.

***See explanation on function codes following Table C-1 for a breakdown of the three possible groups.

****3600/3800 systems

*****3100/3200/3400 systems

STATUS

Status codes permit the monitoring of several control/unit operating conditions. These codes are made available to the data channel over 12 status lines following a connect or a rejected connect attempt. Sense Status and Copy Status instructions make these codes available to the central processor.

See Table C-2 for a complete list of these codes. If two or more conditions exist simultaneously, the Status Response code is the sum of the individual codes. A detailed description of each code follows the table.

PARITY CHECKING (TRANSMISSION)

Connect codes, function codes, and data are transmitted between the data channel and the controller in odd parity (i. e., the number of "1" bits transmitted must be odd). If the number of "1" bits in a data byte is even, a "1" is transmitted on the parity line to make the total number of "1" bits odd.* If the number of "1" bits in the data byte is odd, the "1" is not transmitted on the parity line.

A transmission parity error exists if the total number of "1" bits transmitted on the 12 data lines plus the parity line is even, indicating that a bit has been lost or picked up.

Parity Error in a Connect Code

If a parity error is detected in a Connect code, the device does not connect** and neither a Reject nor a Reply is returned to the data channel. Instead, the Parity Error indicator of the equipment detecting the error lights. These parity error conditions must be cleared by either a Clear Channel instruction or a Master Clear prior to a new connect attempt.

Parity Error in a Function Code

If a parity error is detected, the requested functions are not performed, a Parity Error signal is returned to the data channel, and the Parity Error indicator lights. Since neither a Reject nor a Reply is returned to the data channel, the central processor generates an Internal Reject after a wait of 100 microseconds. These parity error

*Do not confuse this line with the parity error line.

**If the device is connected, it automatically disconnects.

indications must be cleared by a Clear Channel instruction or a Master Clear.* The equipment must then be reconnected before a new function code can be examined by the controller.

Parity Error in Output Data

If a transmission parity error is detected by the controller during a Write operation, the controller lights a red indicator in its Equipment Number switch and sends both a Reply and a Parity Error signal to the data channel. The data is written on tape. All operations continue** unless appropriate programming steps have been taken to sense the Parity Error and rewrite the data. These parity error indications must be cleared by either a Clear Channel instruction or a Master Clear. The equipment must then be reconnected and the appropriate functions reselected prior to the new output.

Input/Output Parity Error Bit in the Data Channel

The input/output parity error bit is set whenever a transmission parity error is detected. If the error is detected by the external equipment, the bit is set by the Parity Error signal.

In 3400/3600/3800 systems, an Interrupt signal is generated when this bit sets. If the interrupt system has not been set to detect the setting of this bit, the bit may be sensed to detect parity error conditions.

In 3100/3200 systems, the bit must be sensed if transmission parity error conditions are to be detected by the central processor.

Refer to the appropriate system reference manual for more information on the input/output parity error bit.

CODES

Tables C-2 and C-3 list all codes that apply to the 3293 Plotter. A detailed explanation of each code follows the table. In all codes, bit 0 is in the rightmost position.

*Though operations may continue normally, the validity of a new function code and/or data prior to a Master Clear or Clear Channel instruction is questionable.

**The validity of the data received from this point until a Clear Channel instruction or Master Clear is questionable.

TABLE C-2. CONNECT, FUNCTION, AND STATUS CODES

CONNECT	
Connect Plotter	N000*
FUNCTION	
Release and Disconnect	0000
Disassembly Mode	0001
Character Mode	0002
Clear	0005
Select Interrupt on Ready and Not Busy	0020
Release Interrupt on Ready and Not Busy	0021
Select Interrupt on End of Operation	0022
Release Interrupt on End of Operation	0023
Select Interrupt on Abnormal End of Operation	0024
Release Interrupt on Abnormal End of Operation	0025
STATUS	
Ready	XXX1
Busy	XXX2
Stop	XXX4
Interrupt on Ready and Not Busy	X2XX
Interrupt on End of Operation	X4XX
Interrupt on Abnormal End of Operation	1XXX

CONNECT CODE

*Connect Plotter (N000)**

This code connects the plotter. N must match the setting of the Equipment Number switch.

*N = equipment number of controller

FUNCTION CODES

Release and Disconnect (0000)

This code clears all selected interrupts and the Interrupt signal. It puts the controller in Disassembly mode and disconnects the controller.

Disassembly Mode (0001)

This code places the plotter in Disassembly mode. The controller remains in this mode unless code 0002 (Character Mode) is received. Code 0005 (Clear), a Clear Channel instruction, or a Master Clear also places the plotter in Disassembly mode.

Character Mode (0002)

This code places the plotter in Character mode. It remains in this mode until released by code 0001 (Disassembly Mode), code 0005 (Clear), a Clear Channel instruction, or a Master Clear.

Clear (0005)

This code clears all selected interrupts and the Interrupt signal. It puts the controller in Disassembly mode.

Select Interrupt on Ready and Not Busy (0020)

This code causes the controller to send an Interrupt signal to the processor when the plotter becomes Ready and Not Busy (i. e., power is applied, the Master Clear/Ready switch is lighted, and a plotting cycle is not in progress). The control always accepts and replies to this code. Once up, the Interrupt signal remains up until cleared by re-selecting the interrupt (0020), selecting release (0021), Clear (0005), Clear Channel instruction, or Master Clear.

Release Interrupt on Ready and Not Busy (0021)

This code clears an Interrupt on Ready and Not Busy selection and the Ready and Not Busy Interrupt signal if it is up. The control always accepts and replies to this code.

Select Interrupt on End of Operation (0022)

This code causes the controller to send an Interrupt signal to the processor approximately 2* or 7** milliseconds after receipt of a vertical or horizontal motion code or approximately 90* or 92** milliseconds after receipt of a code that raises or lowers the pen. The control always accepts and replies to this code. Once up, the Interrupt signal remains up until cleared by reselecting the interrupt (0022), selecting release (0023), Clear (0005), Clear Channel instruction, or Master Clear.

Release Interrupt on End of Operation (0023)

This code clears an Interrupt on End of Operation selection and the End of Operation Interrupt signal if it is up. The control always accepts and replies to this code.

Select Interrupt on Abnormal End of Operation (0024)

This code causes the control to send an Interrupt signal to the processor when an abnormal end of operation occurs. The control always accepts and replies to this code. Once up, the Interrupt signal may be cleared by reselecting the interrupt (0024), selecting release (0025), Clear (0005), Clear Channel instruction, or Master Clear.

Release Interrupt on Abnormal End of Operation (0025)

This code clears an Interrupt on Abnormal End of Operation selection and the Abnormal End of Operation Interrupt signal if it is up. The control always accepts and replies to this code.

STATUS CODES

Ready (XXX1)

Bit 0 is set if the plotter is mechanically Ready.

* Character mode
** Disassembly mode

Busy (XXX2)

Bit 1 is set when Plotter Movement codes are being transmitted to the plotter or during a period of approximately 2 or 90 milliseconds* while a mechanical operation is executed.

Stop (XXX4)

Bit 2 indicates that the Stop switch was pressed.

Interrupt on Ready and Not Busy (X2XX)

Bit 7 indicates that Interrupt on Ready and Not Busy was selected and that this condition now exists.

Interrupt on End of Operation (X4XX)

Bit 8 indicates that Interrupt on End of Operation was selected and that this condition now exists.

Interrupt on Abnormal End of Operation (1XXX)

Bit 9 indicates that Interrupt on Abnormal End of Operation was selected and that this condition now exists.

PLOTTER MOVEMENT CODES

These codes specify plotter movements. They are transmitted to the plotter by a Write (Output) instruction. A single $\pm x$ or $\pm y$ code makes the plotter move one step (0.01 or 0.005 inch, depending on plotter model**). A single $\pm x \pm y$ combination makes the plotter move in a 45-degree angle approximately 0.014 or 0.007 inch (see Figure C-2). Table C-3 lists the Plotter Movement codes.

*Vertical or horizontal (2 milliseconds) and raising or lowering the pen (90 milliseconds)

**See Table C-1, Plotter Specifications.

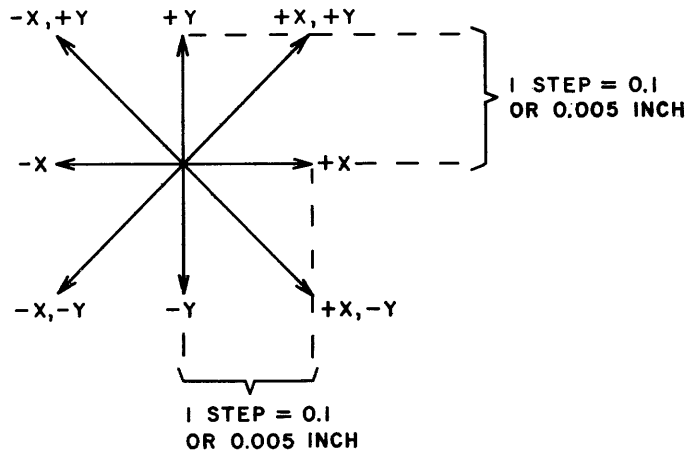

Figure C-2. Plotter Steps

TABLE C-3. PLOTTER MOVEMENT CODES

DESIRED MOVEMENT	CODE* (6 BITS)
+X	01
-X	02
+Y	04
+X +Y	05
-X +Y	06
-Y	10
+X -Y	11
-X -Y	12
Lower Pen	20
Raise Pen	40

*Any codes not listed are do-nothing codes.

SWITCHES AND INDICATORS

CONTROLLER SWITCHES AND INDICATORS

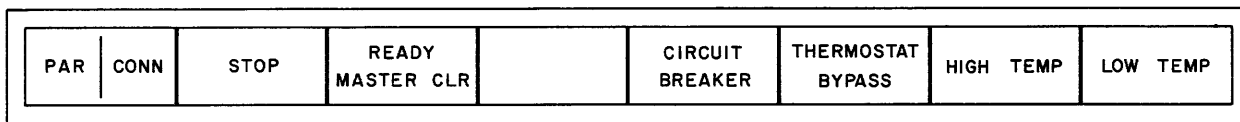

Figure C-3. 3293 Controller Panel

PAR/CONN Indicator

The Parity indicator lights when a parity error is detected. The Connect indicator lights when the data channel connects the plotter.

STOP Switch

This switch stops the plotter. It lights to show Stop condition. This switch also lights when power is turned on.

READY/MASTER CLR Switch

This switch clears plotter for next program. It lights to show Ready condition.

CIRCUIT BREAKER Indicator

This indicator indicates that power has been removed from circuits because of an overload.

CALCOMP PLOTTER SWITCHES AND INDICATORS

POWER ON/OFF Switch

This switch turns unit on or off.

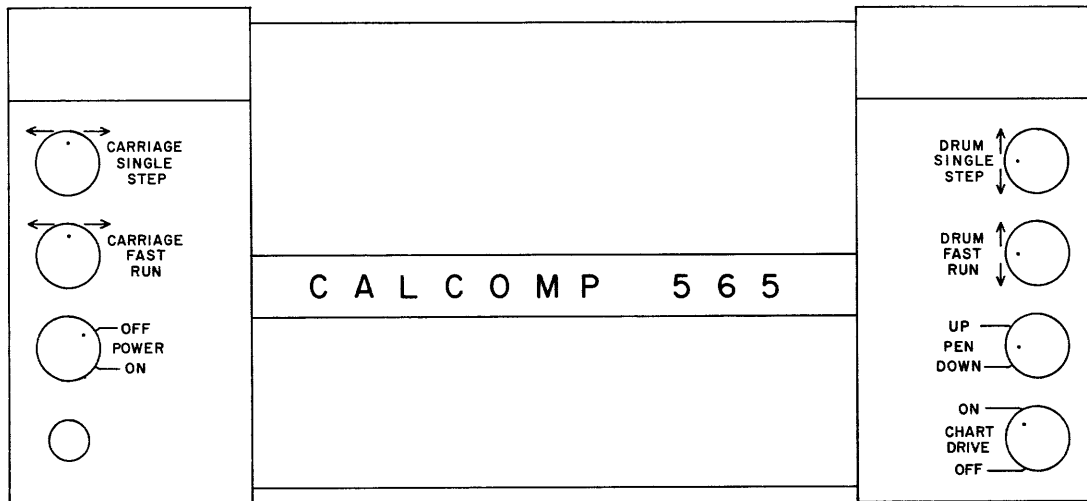

Figure C-4. Calcomp Switches and Indicators

CARRIAGE SINGLE STEP Switch

This switch moves the pen in +x or -x direction one step.

CARRIAGE FAST RUN Switch

This switch moves the pen in +x or -x direction at rate of 120 steps/second.

DRUM SINGLE STEP Switch

This switch moves the paper in +y or -y direction one step.

DRUM FAST RUN Switch

This switch moves the paper in +y or -y direction 120 steps/second.

PEN UP/DOWN Switch

This switch raises or lowers the recording pen.

CHART DRIVE ON/OFF Switch

This switch is used for making single sheet graphs instead of roll graphs.

OPERATION AND PROGRAMMING

PLOTTER PREPARATION

Prepare the plotter for operation according to the following procedures:

- 1) Press CIRCUIT BREAKER switch on controller.
- 2) STOP indicator on controller should be lighted.
- 3) Ready Calcomp plotter as follows:
 - a) Place plotter POWER switch at ON.
 - b) Place CHART DRIVE switch at ON.
 - c) Load paper roll on plotter according to instructions in Calcomp manual.
 - d) Position drum for a reserve of paper on roll by using DRUM FAST RUN switch.
 - e) Position carriage pen holder to center of roll by using CARRIAGE FAST RUN switch.
 - f) Check pen to see if it moves up and down when PEN switch is turned.
 - g) The Calcomp plotter is now ready; continue to step 4.
- 4) Press READY/MASTER CLR switch to alert computer.
- 5) Plotter is now ready to operate under program control.

PLOTTER SIZE

The programmer must consider the size of the Calcomp plotter being used. The 12-inch plotter has approximately 5-3/4 inches from center to edge on the X axis. This is 575 steps in either direction on some models (0.01 movement per step) and 1,150 steps on other models (0.005 movement per step).

The 29-inch plotter has approximately 14-1/4 inches from center to edge on the X axis. This width allows 1425 steps (0.01 step plotter) or 2850 steps (0.005 step plotter) either direction from center.

SECTION D

3458-A PRINTER CONTROLLER

CONTENTS

Introduction	D-1	Printer Preparation Procedures	D-27
Publications	D-1	Carriage Control Tape Punching Procedure	D-34
Physical Description	D-1	Programming	D-35
Characteristics	D-1	Connect	D-35
Functional Description	D-3	Function Codes	D-35
1403 Printer Description	D-3	Status Codes	D-41
3458 Controller Description	D-8	Interrupts	D-44
Controls and Indicators	D-11	Data Transfer	D-44
3458 Controller	D-11	Parity Checking	D-49
1403 Printer	D-16	Equipment Error Checking	D-50
Operation	D-24	Programming Considerations	D-52
Subsystem Preparation	D-24	Programming Example	D-53
System Operation	D-25		
Subsystem Shutdown	D-27		

FIGURES

D-1 Subscan Alignment Sequence	D-5	D-7 1403 Carriage Indicator Panel	D-22
D-2 Typical Configuration	D-8	D-8 Forms Tractor Mechanism (Mod 2 Printer)	D-28
D-3 3458 Maintenance Panel	D-12	D-9 Forms Tractor Mechanism (Mod 3 Printer)	D-29
D-4 1403 Printer, Mod 2 (Front View - Cover Raised)	D-17	D-10 Carriage Control Tape Mechanism	D-31
D-5 1403 Printer, Mod 3 (Front View - Cover Raised - Paper Installed)	D-18	D-11 Train Assembly (Mod 3 Printer)	D-33
D-6 1403 Main Switch and Indicator Panel	D-21	D-12 Spacing Example	D-54

TABLES

D-1 1403 Printer Characteristics	D-2	D-4 Status Codes	D-41
D-2 3458 Controller Characteristics	D-2	D-5 Standard 48 Character-Set	D-46
D-3 Function Codes	D-36	D-6 Standard 60 Character-Set	D-47
		D-7 Standard 64 Character-Set	D-48

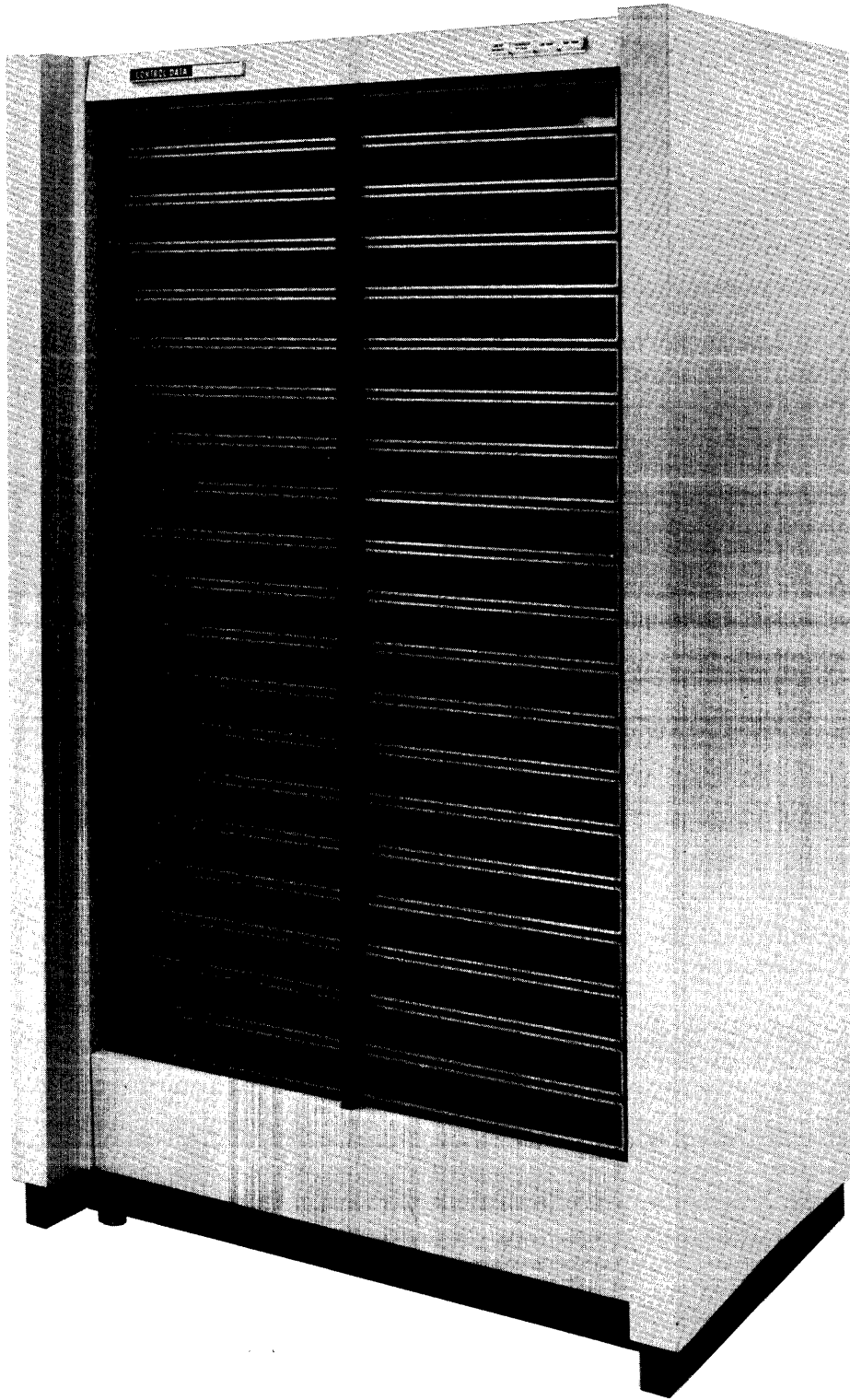

3458 PRINTER CONTROLLER

SECTION D

3458-A PRINTER CONTROLLER

INTRODUCTION

The CONTROL DATA* 3458 Printer Controller operates external to and in conjunction with either the IBM 1403 Model 2 Chain Printer or the IBM 1403 Model 3 Train Printer as a data output device. The 3458 Printer Controller connects to the controlling computer through a single 3000 Series data channel or equivalent.

This section describes the operation of the printer subsystem (controller and printer). It also describes connect, function, and status codes and provides pertinent programming information.

PUBLICATIONS

Consult the following publications for additional information to aid in understanding the controller and printer functions.

3000 Series Computer Systems I/O Specifications

Pub. No. 60048800

The associated printer service manuals

PHYSICAL DESCRIPTION

The controller consists of a modified Type C cabinet with a standard 400-hertz logic power supply, a special -60-volt power supply, a power distribution panel that channels 208-volt, 3-phase, 60-hertz power to the printer, a logic chassis with a control panel, and special connectors with power and control cables for connection to the printer. (The logic chassis must have a CONTROL DATA 1604 Type 00 jumper card in location G35 before the controller can be used with a Mod 2 printer.)

CHARACTERISTICS

Refer to Table D-1 for a list of printer characteristics. Refer to Table D-2 for a list of controller characteristics.

* Registered trademark of Control Data Corporation

All printers used with a 3458 must have been modified as described in Control Data Dwg. No. 18067500.

The Mod 3 printer must contain the Universal Character Feature, IBM Number 8640, for correct synchronization during 60 and 64 character-set operation.

The Mod 2 printer must contain the Universal Character Feature, IBM Number 8641 and the Interchangeable Chain Cartridge Adapter Feature if used for 60 and 64 character-set operation.

TABLE D-1. 1403 PRINTER CHARACTERISTICS

GENERAL	
Line Length:	132 characters
Line Density:	six and eight lines per inch
Character-Set:	48, 60, or 64 alphanumeric
Printing Rate (single line spacing):	
Mod 2:	600 lines per minute
Mod 3:	1100 lines per minute when using a 48 character-set, five-array train assembly
Mod 3:	950 lines per minute when using a 60 character-set, four-array train assembly
Mod 3:	950 lines per minute when using a 64 character-set, four-array train assembly and only the 59 preferred characters
Mod 3:	310 lines per minute when using a 64 character-set, four-array train assembly and all characters
Paper Motion:	Low speed during spacing of eight lines or less High speed during spacing of more than eight lines
ELECTRICAL	
Input Voltage:	208 volts, 3-phase, 60 hertz -60 vdc +12 and -12 vdc +6 and -6 vdc

TABLE D-2. 3458 CONTROLLER CHARACTERISTICS

PHYSICAL	
Dimensions:	75 inches high x 43-11/32 inches wide x 20-1/2 inches deep
Weight:	Controller - 1140 pounds, Cables - 160 pounds
GENERAL	
Operating Mode:	Internal BCD or external BCD
Data Word Characteristics:	6-bit (suppress disassembly) or 12-bit (disassembly)
Error Checking:	Program, print, sync, and memory parity

TABLE D-2. 3458 CONTROLLER CHARACTERISTICS (Cont'd)

Translator Matrixes: (Supplementary items)	
PA3 and PA4	48 character-set train assembly
PA5 and PA6	60 character-set train assembly
PA1 and PA2	64 character-set train assembly
ENVIRONMENTAL	
Temperature:	60° to 90° F
Relative Humidity:	30% to 80%
Cooling:	Blower circulating air at 400 CFM
Mounting:	Place on false floor or 6 inches above a solid floor to facilitate cabling
ELECTRICAL	
Input Voltage:	208 volts, 3-phase, 400 hertz 208 volts, 3-phase, 60 hertz

FUNCTIONAL DESCRIPTION

1403 PRINTER DESCRIPTION

The 1403 Printer is a peripheral device which prints information from a computer on continuous-form paper which moves vertically between horizontal rows of print hammers and type faces. Printing and paper advance are completely controlled by the 3458 and the computer program.

Chain and Train Assemblies

The chain assembly (used with Mod 2 printers only) contains a plastic-coated steel tape to which a series of type slugs are attached to form an endless loop around the assembly. Each slug contains type for two characters and the slugs are arranged into groups called arrays. The loop contains 48 characters in each array and a total of five arrays. This chain assembly is referred to as a 48 character-set chain assembly.

The train assembly (used with Mod 3 printers only) is made up of a series of type slugs containing gear teeth and a track channel for mounting on a guide track. The slugs are not connected together and are driven by a drive gear at one end of the assembly. Each slug contains type for three characters and there are a total of 80 slugs. The 48 character-set train assembly contains five arrays with 48 characters in each array. The 60 and 64 character-set train assemblies contain four arrays with 60 characters in each array although the character arrangement within arrays differs between the assemblies.

The arrays are identical on any given 48 character-set train or chain assembly and contain 26 alphabetic, 10 numeric, and 12 symbol characters. The arrays are identical on any given 60 character-set train assembly and each array contains 26 alphabetic, 10 numeric, and 24 symbol characters. The arrays are identical on any given 64 character-set train assembly except for the 60th character. Because of this, the assembly is referred to as a 59 preferred, four-array train assembly. The four nonpreferred characters are the 60th, 61st, 62nd, and 63rd characters which are located as follows: the 60th character is in the 60th character position of the first array; the 61st character is in the 60th character position of the second array; the 62nd character is in the 60th character position of the third array; and the 63rd character is in the 60th character position of the fourth array. The 64th character provided for use with this train assembly is a blank but does not appear as a separate blank portion of a type slug. Printing of the nonpreferred characters is performed at low speed. Each array contains 26 alphabetic, 10 numeric, and 24 special symbols.

Since the arrays differ between the standard chain and train assemblies, each assembly used requires a separate controller translator matrix.

Printing

Introduction: Printing is accomplished by the timed firing of print hammers as the characters on the chain or train assembly move continuously along the printing line at a constant speed. When a hammer fires, it drives the paper and printing ribbon against the moving type. As the paper and ribbon make contact with the character type, the character is printed on the paper.

Each line may contain up to 132 characters or print positions. Each print position has a separate print hammer and an associated position in the controller buffer storage.

Since there is less space between hammers than between characters on the chain assembly (see Figure D-1), consecutive characters do not align with consecutive hammers. Due to this difference in spacing, a printing sequence of every second character and every third hammer results. At any one instant, only one character and one hammer are in perfect alignment for printing and only one hammer fires at a time.

To print a line of information, characters on the 48 character-set chain or train assembly are scanned 48 times. Each of these scans is called a print scan and is the time required to afford each hammer the opportunity of printing one character. With 48 characters on the chain or train assembly, there must be 48 print scans to afford each hammer the opportunity of printing all of the 48 characters. Since a print scan is divided

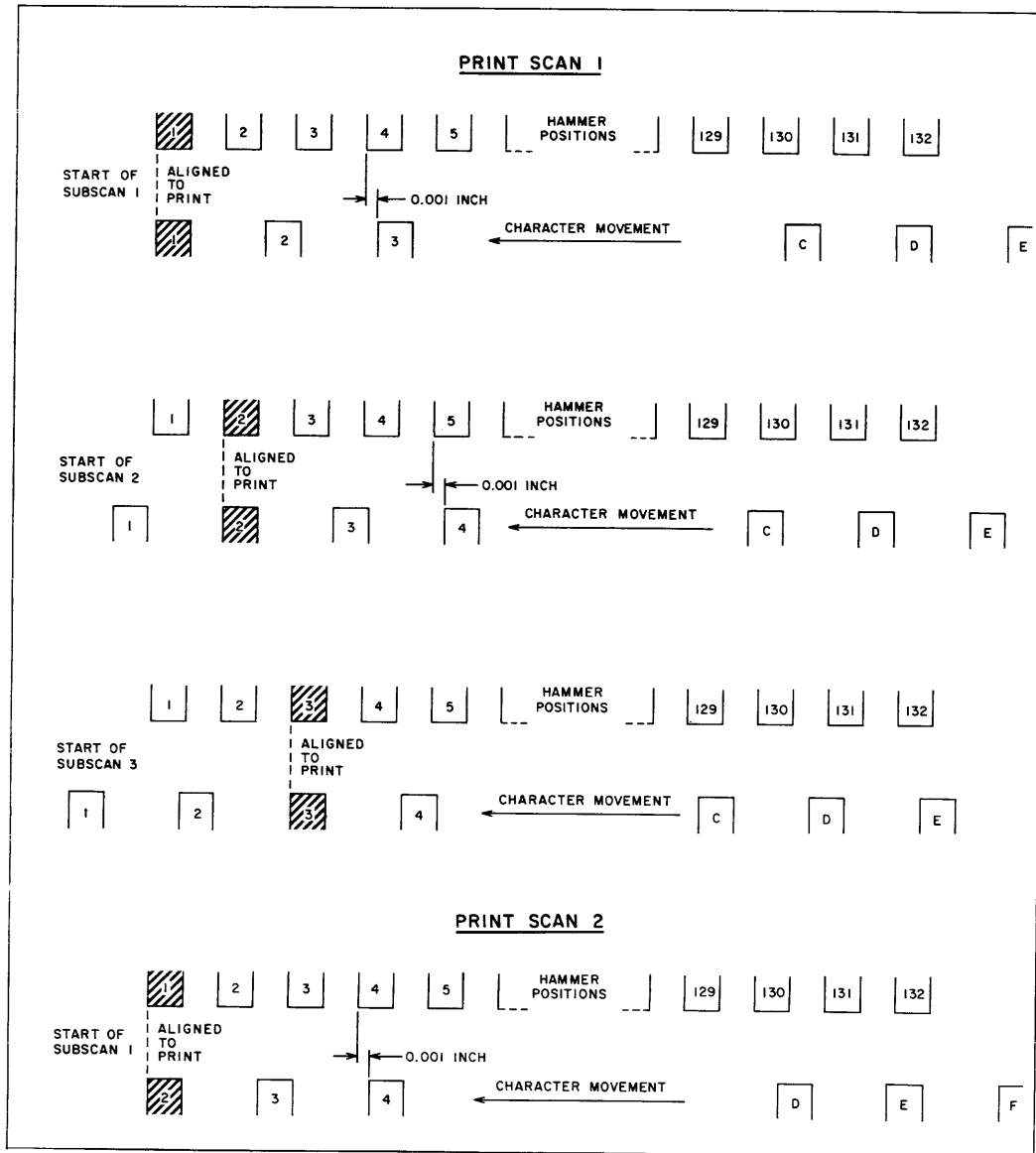

Figure D-1. Subscan Alignment Sequence

into three subscans, each subscan affords one-third of the hammers the opportunity of printing one character.

Printing Operation: In the following explanation of print scans and subscans, operation of the 48 character-set chain assembly is explained. The 48 character-set train assembly operates identically. The operation of the 60 character-set train assembly differs from the explanation only in that 60 print scans are required to print a line of information. The operation of the 64 character-set train assembly differs from the explanation only in that 240 print scans are required to print a line of information if any of the nonpreferred characters are used in printing. If only the preferred characters are printed, 60 print scans are required.

The following explanation assumes a starting position with the number of "1" aligned with hammer 1 to illustrate the printing operation although printing can begin when any character in an array is aligned with hammer 1. Refer to Figure D-1. At the start of subscan 1, the character in storage is compared with the number "1" aligned to print. If the characters are identical, hammer 1 fires and prints the number "1".

During the printing of the number "1," character movement is 0.001 inch, which aligns the number "3" with hammer 4. A comparison is again made between the character in storage to be printed and the number "3" aligned with hammer 4. If they are identical, hammer 4 fires and prints the number "3." (Note that the movement of the chain assembly establishes an alignment sequence of every second character, every third hammer.) This sequence continues until character C is aligned with hammer 130 at the 44th comparison and at the end of subscan 1.

At the end of subscan 1, the total chain assembly movement is sufficient to align the second character (the number "2") with hammer 2. This is the start of subscan 2. The character in storage is compared with the number "2" aligned to print. If the characters are identical, hammer 2 fires and prints the number "2." Comparisons and printing then proceed with every second character and every third hammer until the character "D" aligns with hammer 131 at the 44th comparison and at the end of subscan 2.

At the end of subscan 2, the total chain assembly movement is sufficient to align the third character (the number "3") with hammer 3. This is the start of subscan 3. The character in storage is compared with the number "3" aligned to print. If the characters are identical, hammer 3 fires and prints the number "3." Comparisons and printing then proceed with every second character and every third hammer until the character

"E" aligns with hammer 132 at the 44th comparison and at the end of subscan 3. One print scan has now been completed.

After subscan 3 of print scan 1, print scan 2 starts with the number "2" aligned with hammer 1. If the character in storage to be printed is the number "2," hammer 1 fires and prints the number "2." Again, comparisons and printing take place as in print scan 1. Note in this example that at the start of print scan 1, the number "1" aligns with hammer 1 and at the start of print scan 2, the number "2" aligns with hammer 1. In this manner, hammer 1 will have been aligned with all 48 characters on the chain assembly after 48 print scans. All other hammers have also been aligned in the same manner after 48 print scans. A complete line has now been printed by the printer.

Paper Advance

The continuous-form paper in the printer moves upward from a bulk supply contained on a tray under the printer. The paper passes between the print hammers and the type faces on the chain or train assembly and over the curved paper guides at the top of the printer. The paper then continues down through the stacker at the rear of the printer where it is stacked in bulk for removal by the operator.

Paper advances through the printing station in one of two modes as determined by the computer program and the carriage control tape: low-speed or high-speed paper spacing. Low-speed paper spacing is a line-by-line advancement of the paper through the printing station. High-speed paper spacing is moving the paper a predetermined distance in a smooth, uninterrupted manner. Paper spacing of eight lines or more takes place at high speed except for the last eight lines. Paper spacing of less than eight lines takes place at low speed. The carriage control tape controls the stopping of multiple paper spacing operations.

Carriage Control Tape

The carriage control tape is a strip of paper or plastic which is formed into a loop and ruled with parallel lines along its length and width. The lines along its length correspond to the 12 channels or hole positions. Each line across the tape corresponds to a single space of the carriage. The line intersections are necessary to locate the punch positions for new rectangular control holes. The circumference of the tape should correspond to the length, or a multiple of the length of the print paper page it will be used to control. A row of round drive holes runs lengthwise through the center of the tape to facilitate running of the tape in the printer.

The control hole pattern can be designed to permit printing in any desired arrangement. Consecutive control holes in a given channel must not be closer than eight spaces.

Running Time

Operational time of the printer is recorded on the running-time meter located on the printer. The first Write signal after the printer subsystem has been connected to the computer sets up the conditions for recording operational time. Thereafter, a Channel Busy or Computer Running signal initiates actual time recording. Time recording stops when both signals drop and begins when either signal comes up again.

The programmer or operator should press either the CARRIAGE SPACE switch or the CARRIAGE RESTORE switch on the printer after the completion of a program. This prevents time recording when the Channel Busy or Computer Running signals are used for another peripheral subsystem on the same data channel.

3458 CONTROLLER DESCRIPTION

The controller acts as an interface to control the exchange of data between the printer and the computer (see Figure D-2). Receiving commands from the computer via the data channel, the controller executes operations to control the transfer of data and to check the accuracy of this data. In addition, the controller allows the computer to select interrupts and make status response checks.

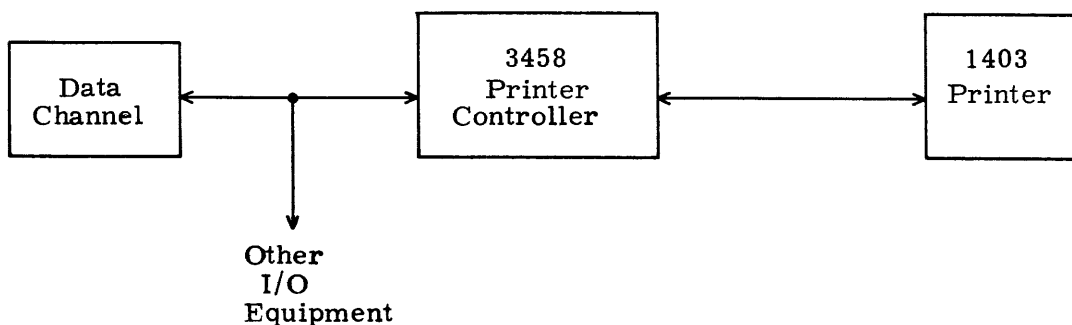

Figure D-2. Typical Configuration

Line Loading

Line loading is the process of placing computer data to be printed in the controller memory. The data is transferred as 12-bit bytes; each byte represents two alphanumeric BCD characters when operating in the 12-bit Disassembly mode. In a printed line, the character designated by the upper 6 bits of a byte is printed to the left of the character designated by the lower 6 bits. In the 6-bit Suppress Disassembly mode, only the lower half of the 12-bit byte representing one character is used. The character codes convert to external BCD in the controller if they enter as internal BCD codes. They remain external BCD codes if they enter the controller in that form.

Controller translator matrixes change an incoming character code from the computer to a code representing the physical position of that character within the array on the train (or chain) assembly being used. This character position code is stored in the controller buffer memory where it is subsequently used for printout of the character. Since the train (or chain) assemblies use a different arrangement of print characters within an array or a different character-set, a unique set of translator matrixes is required for each train (or chain) assembly. The controller stores 132 character positions for one line of data in its nondestructive-type magnetic core memory. The character position data remains in memory until replaced by character position data representing a new line to be printed. This feature permits the data channel to load one line of characters at high speed and then service another device while the slower printing operation is being performed. The controller generates a memory parity bit as soon as the character position code appears at the output of the translator matrix. The memory parity bit is stored with its character position code in controller memory. An Error Detector circuit registers the loading of each character position code in memory. A column indicator corresponding to the eventual print position of the loaded character lights as each character position code is loaded in memory.

In one line of data containing up to 132 characters, 66 bytes of data (Disassembly mode) are required and are considered a block of data. (A block of data consists of 132 bytes of data when operating in Suppress Disassembly mode.) If a block of data contains more than 132 character position codes, all codes above 132 are lost. The controller replies to the extra data and then discards it. The controller memory does not accept a new byte of data until the Write signal is dropped and brought up again. If the data channel terminates an Output operation before a full line is formed, the remainder of the line loads with blanks. The partial line is printed and a new Output operation starts a new line.

Print Operation

In printing one line of data, a comparison is made between the character aligned with a hammer in the printer and the character in memory. If the two are identical, the character is printed. The characters on the train (or chain) assembly are continually scanned until the 132 print hammers in the printer have had the option of printing each of the stored characters. The number of print scans required to option all hammers depends on the train (or chain) assembly being used in the printer.

The character position code is checked for memory parity error each time it is involved in a print option. Presence of a memory parity error is registered in the controller ErrorDetector circuit for that character position code and a Print Error status signal is initiated upon completion of the printing of the line of data. The column indicator corresponding to this code remains on after the character is printed. The indicator goes out when a character is printed. There is no memory parity error or any other error which causes a Print Error status signal to be initiated.

Paper Advance

This process controls paper spacing in the printer so that succeeding lines may print on a blank area. Paper automatically advances one space after a line is printed if other spacing operations are not programmed. Paper advance can be computer programmed to occur before printing a line (Preprint mode) or after printing a line (Postprint mode). Paper advance can also be initiated by the CARRIAGE SPACE (single space) or CARRIAGE RESTORE (page eject) switches on the controller or the printer.

All preprint function codes and programmed single space, double space, and page eject cause spacing operations to occur directly. All postprint function codes cause spacing operations to occur upon completion of the Print operation. The preprint, postprint, and page eject spacing operations (except single space and double space) are speed controlled by the carriage control tape in the printer. The spacing operations (except single and double space) are terminated under control of the carriage control tape. Once a spacing operation begins, the paper advances until a hole is detected in a preselected position on the carriage control tape.

CONTROLS AND INDICATORS

3458 CONTROLLER

Indicator Switches

Refer to Figure D-3 for the physical location of the indicator switches on the controller. The following provides a functional description for each indicator switch.

Equipment Number Indicator Switch: The connect logic is governed by an 8-position rotary switch which specifies the equipment number for the controller. The setting of this switch (with positions 0 through 7) designates the controller and corresponds to the N portion of the Connect code. It also determines the number of the interrupt transmission line used by the equipment.

A white indicator in this switch lights whenever the controller is connected; a red indicator lights when a transmission parity error is detected. The red parity error indication is turned off by a Release and Disconnect instruction, a Clear Channel instruction, a Master Clear, or by first pressing the START switch and then the STOP switch.

PRINTER ON Indicator Switch: This momentary-contact switch applies 208-volt, 3-phase, 60-hertz power to the printer if +20, -20, and -60-volt power is present and all interlocks are closed.

A white indicator in this switch lights to indicate that the printer is mechanically Ready. The indicator goes out if the PRINTER OFF switch is pressed, if the circuit breaker trips, if any one of the power supply voltages drops below tolerance, or if one of the interlocks opens.

START Indicator Switch: This momentary-contact switch causes the printer subsystem to become Ready which permits starting of the Print operation if all of the following conditions are present at the printer:

- 1) Presence of print paper
- 2) Carriage interlock closed
- 3) Format tape installed

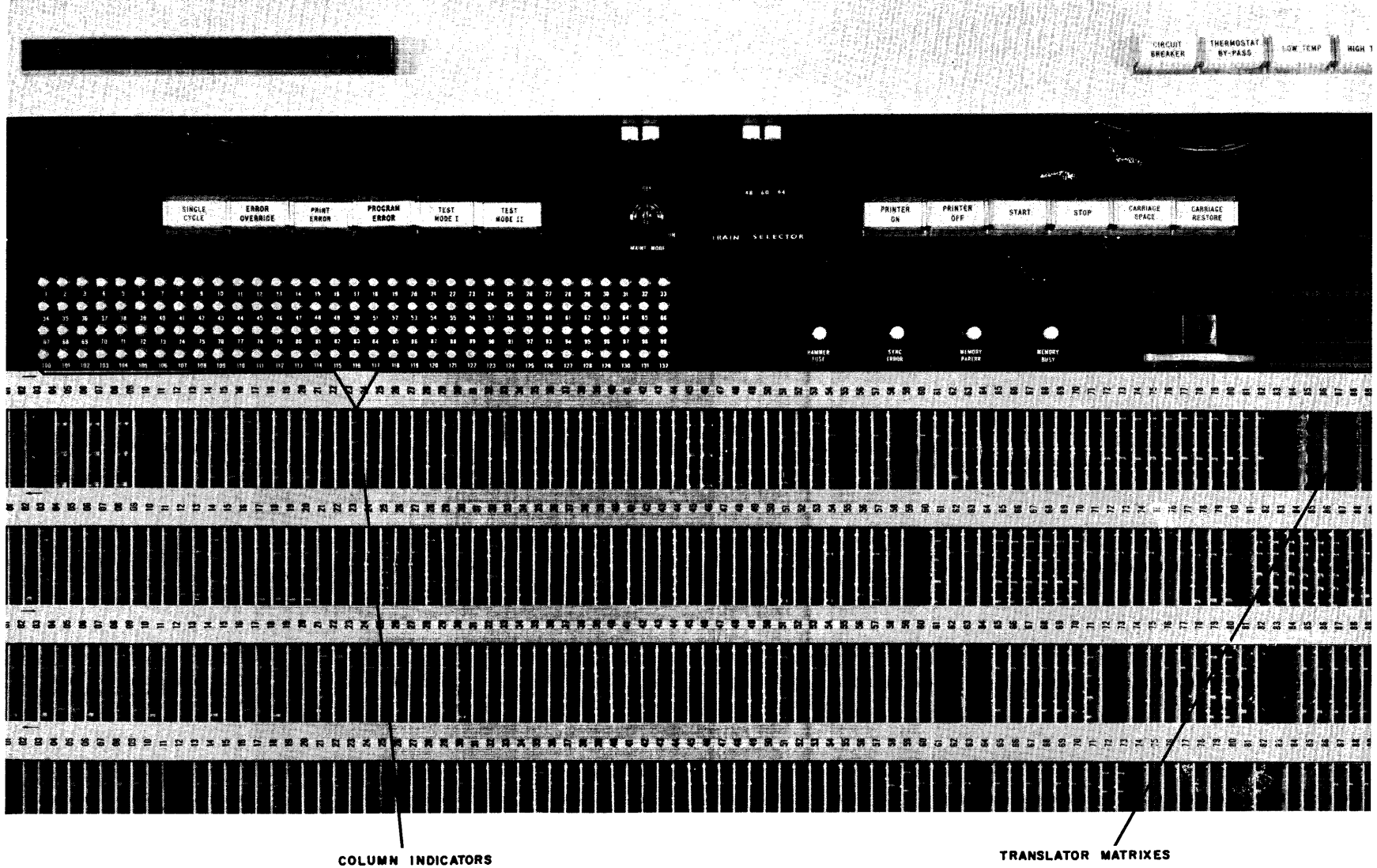

D-12

Figure D-3. 3458 Maintenance Panel

- 4) Operating voltages present
- 5) Print paper not torn

A white indicator in this switch lights to indicate that the printer subsystem is Ready. The indicator goes out if the STOP switch is pressed or if the printer subsystem becomes Not Ready.

ERROR OVERRIDE Indicator Switch: This 2-position switch provides the option of printing or stopping printing upon detection of a transmission parity error. It can also inhibit the Interrupt on Abnormal End of Operation, if selected, caused by the following:

- 1) Memory parity error
- 2) Print error
- 3) Sync error

TEST MODE I Indicator Switch: This 2-position switch causes the line currently in controller memory to print repeatedly for checking purposes. The switch is used by maintenance personnel only and remains in the off position during normal operation of the subsystem. The operator should not attempt to use this switch.

TEST MODE II Indicator Switch: This 2-position switch allows printing to start only when the first character of an array is aligned with print position one. The switch is normally used by maintenance personnel only and remains in the off position during normal operation of the printer subsystem.

A red indicator in this switch lights when the switch is in the TEST MODE II position.

Switches

Refer to Figure D-3 for the physical location of the switches on the controller. The following provides a functional description of each switch.

MAINT. MODE Switch: This 2-position keylock switch disables the running-time meter in the printer while maintenance checks are being run on the printer subsystem. The switch is normally used by maintenance personnel only and remains in the OFF position during normal operation of the subsystem.

TRAIN SELECTOR Switch: This 3-position switch allows the controller to operate with a 48, 60, or 64 character-set train assembly or 48 character-set chain assembly. The switch setting must correspond to the character-set and translator matrix of the train or chain assembly being used.

PRINTER OFF Switch: This momentary-contact switch removes the 3-phase power from the printer.

STOP Switch: This momentary-contact switch stops the printer subsystem at completion of the operation in progress or prevents the starting of an operation, causing the subsystem to become Not Ready.

CARRIAGE RESTORE Switch: This momentary-contact switch advances the paper to the top of the next form under control of carriage tape level 1.

CARRIAGE SPACE Switch: This momentary-contact switch advances the paper one space.

SINGLE CYCLE Switch: This momentary-contact switch enables a one-line printout after an End of Forms condition exists. This single-cycle operation may be repeated until the physical bottom of the form is reached or until the top of form on the carriage control tape is reached. It places the printer subsystem in a Ready condition while a line prints.

Indicators

Refer to Figure D-3 for the physical location of the indicators on the controller. The following provides a functional description for each indicator.

PRINT ERROR Indicator: The PRINT ERROR indicator lights at completion of a print line if one or more of the following conditions exist:

- 1) A character position code was loaded into the buffer memory but the character was not printed.
- 2) A character was printed even though the position code of that character was not loaded into memory.

- 3) There were one or more memory parity errors.
- 4) A given hammer fired more than once during the line printout.
- 5) There was a sync error between the type on the printer train (or chain) assembly and the controller position counter circuitry.

All print error conditions, except sync error, can be traced to specific columns by observing the column indicators. (A sync error is indicated by the SYNC ERROR indicator.)

The indicator goes out when the next Channel Busy signal arrives at the controller, when the CHECK RESET switch is pressed on the 1403, or by a Clear Channel instruction or a Master Clear.

PROGRAM ERROR Indicator: The PROGRAM ERROR indicator lights whenever an illegal character code (see Tables D5 and D6, pages D-46 and D-47) is transmitted to the controller.

The indicator goes out when the next Channel Busy signal arrives at the controller, when a Release and Disconnect function is received, or by a Clear Channel instruction or a Master Clear.

Column Indicators (132 total): A column indicator lights as each character position code loads into memory. The indicator denotes the print position of the character. A blank or illegal code loads into memory but does not light a column indicator.

The indicator goes out when the character is printed. Any indicator remaining lighted after the line is printed indicates an error in that column. The type of error can be determined by observing the PRINT ERROR and MEMORY PAR ERR indicators. (See Print Error (2XXX) in the Programming portion of this section.)

MEMORY PAR ERR Indicator: The MEMORY PAR ERR indicator lights when a character position code from memory does not have odd parity (controller generated). The error can be traced to a specific printed character by observing the column indicators. If more than one column indicator is lighted, at least one character represented by the column indicators has a memory parity error.

The indicator goes out when the next Channel Busy signal arrives at the controller, when the CHECK RESET switch is pressed on the 1403, or by a Clear Channel instruction or a Master Clear.

SYNC ERROR Indicator: The SYNC ERROR indicator lights when the printer train (or chain) assembly position and the controller position counter circuitry are not synchronized.

The indicator goes out when:

- 1) The printer train (or chain) assembly is at home position while the controller position counter contains a count of one and printing has not started.
- 2) The next Channel Busy signal arrives at the controller.
- 3) The CHECK RESET switch is pressed on the 1403.
- 4) The Clear Channel instruction or a Master Clear signal is received.

MEMORY BUSY Indicator: The MEMORY BUSY indicator lights when the first data word of a new line loads into memory and it remains on until all data in the memory is printed.

HAMMER FUSE Indicator: The HAMMER FUSE indicator lights when one or more hammer fuses open.

1403 PRINTER

Manual Controls

Refer to Figures D-4, D-5, D-8, and D-9 for the physical location of the manual controls on the printer. The following provides a functional description for each manual control.

Lateral Print Adjustment Lever: This lever permits the entire printing mechanism to move horizontally with respect to the print form. When the lever is raised, the translator frame (printing mechanism) is unlocked and can be positioned horizontally within its travel of 2.4 inches.

D-17

3458
Rev F

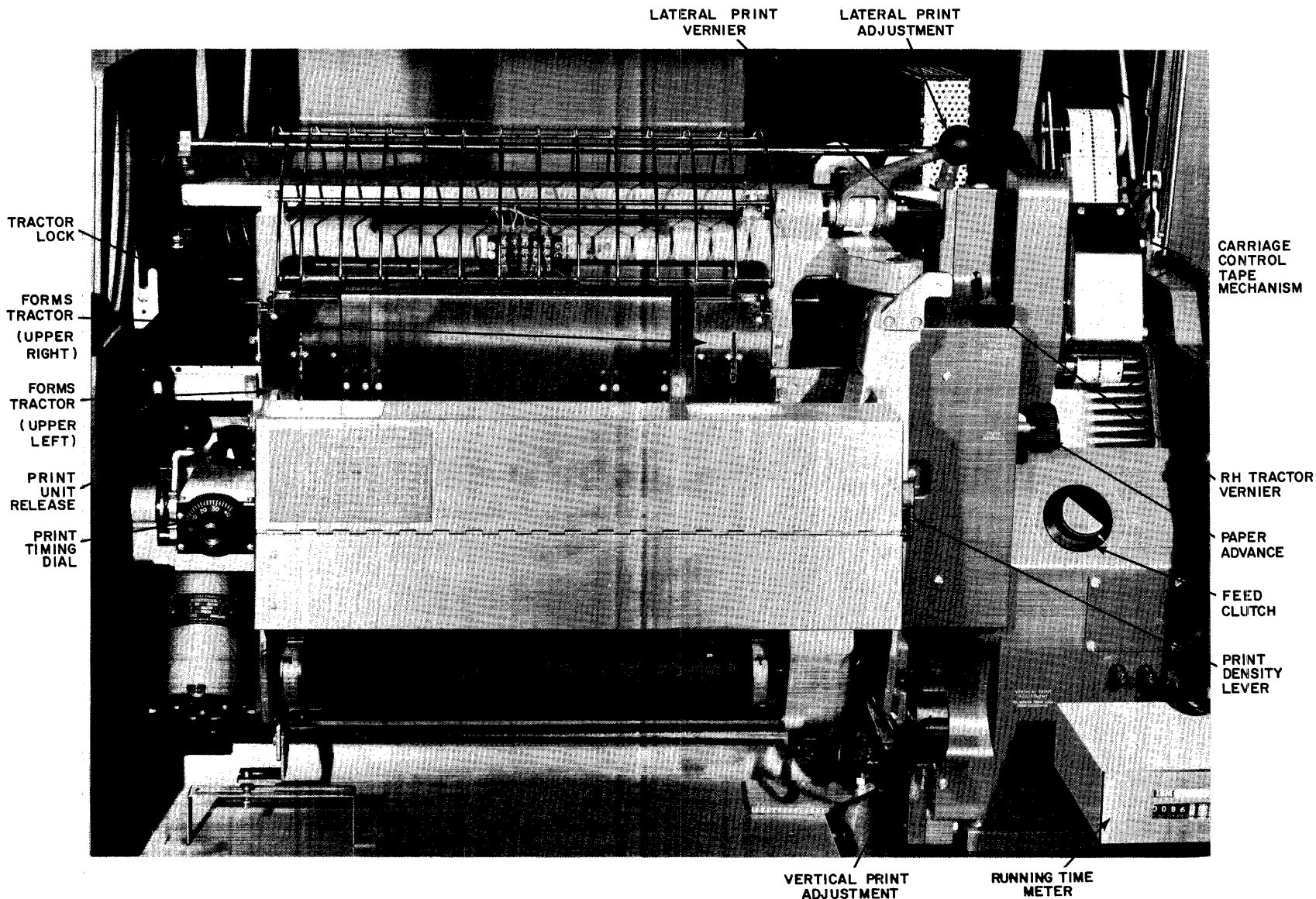

Figure D-4. 1403 Printer, Mod 2 (Front View - Cover Raised)

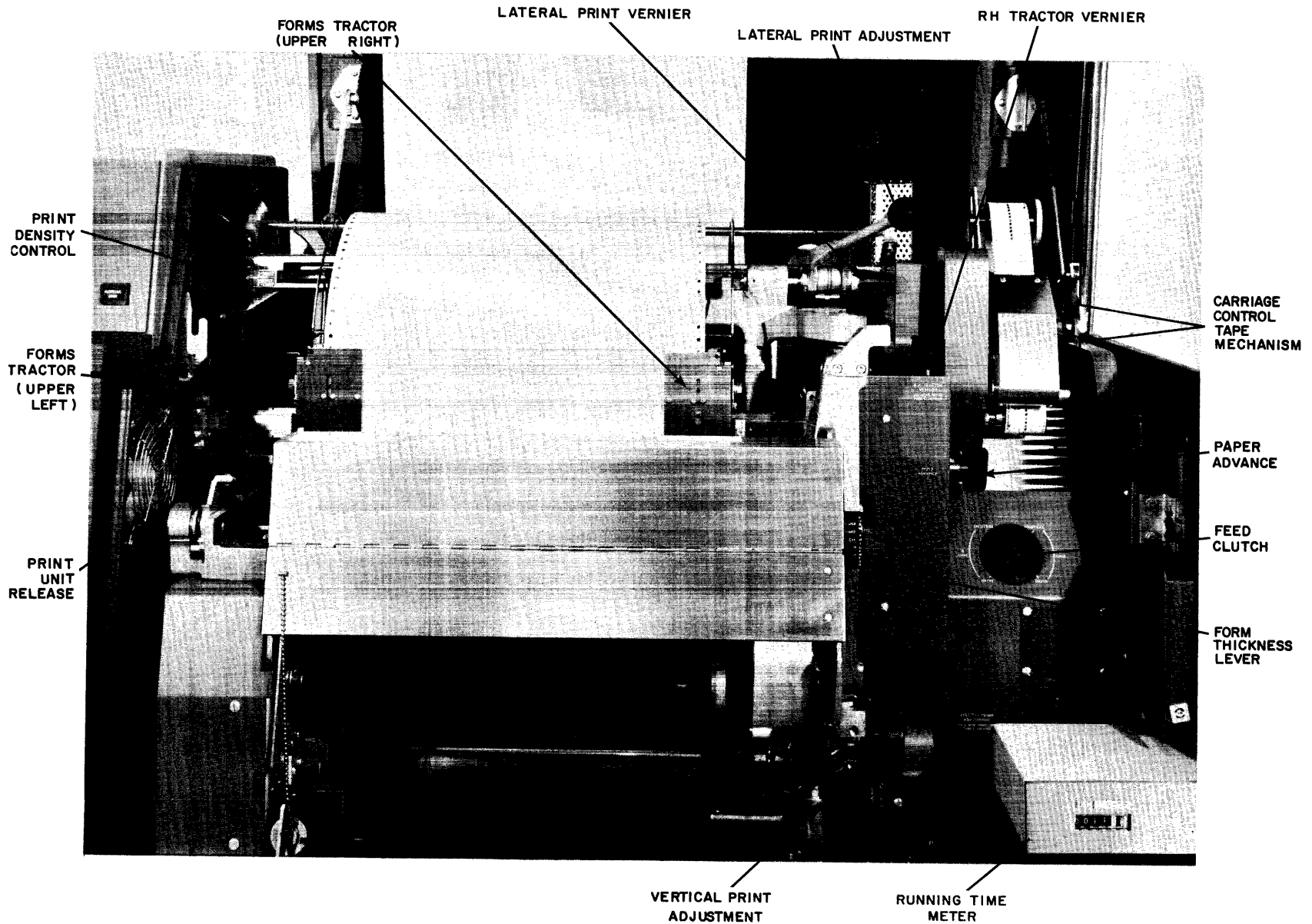

Figure D-5. 1403 Printer, Mod 3 (Front View - Cover Raised - Paper Installed)

Lateral Print Vernier: This vernier provides fine adjustment when aligning the printing mechanism and the print form. It is used after an approximate alignment is made using the lateral print adjustment lever.

Print Timing Dial (Mod 2 only): The print timing dial moves the read head in relation to the timing disk. This movement changes the starting time of hammer firing to compensate for hammer flight and type movement time. It allows each hammer to impinge the ribbon and paper on the type at the instant that the type is in exact alignment with the hammer.

Printing Density Lever (Mod 2 only): This lever permits vernier control of print impression by moving the chain assembly toward or away from the hammer unit. Total movement is about 0.016 inch. When this lever is set at E, print impression is light; when set at A, print impression is dark. Position C is considered the normal setting.

NOTE

The setting of the print density lever together with forms thickness must be used to determine the average setting of the print timing dial.

Print Density Control (Mod 3 only): This knob moves the hammer impression control bar and pad toward or away from the train assembly to control the energy of the hammer at impact. When this control is set at A, print impression is dark; when set at E, print impression is light.

Form Thickness Lever (Mod 3 only): This lever moves the train assembly toward or away from the hammer unit to permit various form thicknesses in both single and multiple copy. Proper setting ensures that the hammer faces are parallel to the type faces at impact.

Vertical Print Adjustment Knob: This knob allows the print line to position vertically with respect to the form. The knob is geared to a sector which turns a horizontal shaft in the translator frame. Two eccentrics on the shaft support the translator frame on two vertical translator slides. The slides are fastened to the translator frame in such a manner that only vertical relative motion is allowed between the slides and the translator frame. When the translator frame is moved horizontally, the frame and slides move as a unit on rollers at the bottom of the slides (see Lateral Print Adjustment Lever).

Forms Tractor Positioning: The forms tractors are mounted on two stationary rectangular guide bars, one above and one below the print line. Two forms tractors are on the upper guide bar, and two are on the lower guide bar. Slots cut into the upper and lower edges of these stationary guide bars are used to position the left forms tractors. The front of each guide bar is recessed and a movable slide fits into this recess. Holes in the face of these slides are used to position the right forms tractors. Thus, the left forms tractors lock to the stationary guide bars, and the right forms tractors lock to the movable slides.

RH Tractor Vernier: This vernier ensures tractor alignment with the pin-feed holes in the form. Turning the vernier knob moves both right forms tractors along the print line.

Paper Advance Knob: This knob is fastened to the right end of the drive shaft for the upper forms tractors. When the feed clutch selection knob is in one of its two disengaged positions, the paper advance knob can move the forms up or down in increments of one line space.

Feed Clutch: This clutch can be set to one of four positions. The two middle positions are disengaged positions. Each of the disengaged positions has a manual detent with a lines-per-inch spacing that corresponds to the adjacent engaged position. The extreme right-detent position is the setting for a spacing of six lines per inch. The extreme left-detent position is the setting for a spacing of eight lines per inch.

Read-Forms-Guide Operating Lever (Paper Guide Control): This lever raises or lowers the rear forms guide.

Stacker-Spring Lift Bar (Mod 2 only): This bar lifts the stacker roll springs away from the rolls to permit gravity stacking of the forms.

Switches

Refer to Figure D-6 for the physical location of the switches on the printer. The following provides a functional description for each switch.

START Switch: The operation performed by this momentary-contact switch is identical to that of the START switch on the 3458. A remote START switch performs the same function and is located at the rear of the printer.

STOP Switch: The operation performed by this momentary-contact switch is identical to that of the STOP switch on the 3458. A remote STOP switch performs the same function and is located at the rear of the printer.

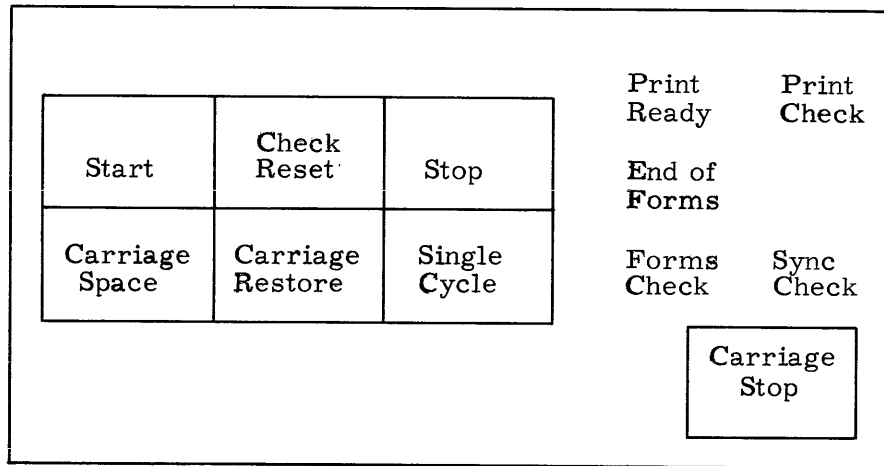

Figure D-6. 1403 Main Switch and Indicator Panel

CHECK RESET Switch: This momentary-contact switch removes all error indications in the printer subsystem except for program error and transmission parity error indications at the controller.

CARRIAGE SPACE Switch: This momentary-contact switch advances paper one space as does the CARRIAGE SPACE switch on the 3458. It also stops the running-time meter (see the description of the running-time meter on page D-8).

CARRIAGE RESTORE Switch: The operation performed by this momentary-contact switch is identical to that of the CARRIAGE RESTORE switch on the 3458. It also stops the running-time meter.

CARRIAGE STOP Switch: This momentary-contact switch stops carriage operation, removes the Ready condition, and prevents the printing of a new line. (A Carriage Stop condition lights FORMS CHECK, HS STOP, and LS STOP indicators on the printer and puts out the 3458 START (Ready) indicator and printer PRINT READY indicator.)

SINGLE CYCLE Switch: The operation performed by this momentary contact switch is identical to that of the SINGLE CYCLE switch on the 3458.

Indicators

Refer to Figures D-6 and D-7 for the physical location of the indicators on the printer. The indicator panel illustrated in Figure D-7 is located on the right front of the printer, above the running-time meter. The following provides a functional description for each indicator.

Gate INLK		HS Start
Brush INLK	Shift INLK	LS Start
	THER INLK	HS Stop
		LS Stop

Figure D-7. 1403 Carriage Indicator Panel

PRINT READY Indicator: This indicator lights when the START switch on the 3458 or the printer is pressed and the printer subsystem is Ready.

The indicator goes out if the STOP switch is pressed or if the printer subsystem becomes Not Ready.

PRINT CHECK Indicator: This indicator is controlled by the same conditions that activate and deactivate the PRINT ERROR indicator on the 3458.

END OF FORMS Indicator: This indicator lights when the printer is out of paper or when there is a break in the form at the lower-left forms tractor.

FORMS CHECK Indicator: This indicator lights when there is a tear in the paper, a paper jam, or when the CARRIAGE STOP switch is pressed.

SYNC CHECK Indicator: This indicator is controlled by the same conditions that control the SYNC ERROR indicator on the 3458.

GATE INLK Indicator: This indicator lights when the T-casting is not locked in position. This condition prevents application of power to the printer train (or chain) motor when the PRINTER ON switch is pressed on the 3458. Locking the T-casting causes the indicator to go out and applies power to the printer train (or chain) motor.

BRUSH INLK Indicator: This indicator lights when the brush assembly is raised. This condition prevents the controller from becoming Ready.

SHIFT INLK Indicator: This indicator lights when the feed clutch is not properly engaged or is not in the proper detent. This condition prevents the controller from becoming Ready. The indicator won't light if the feed clutch is in a neutral detent, only one line will print, and paper will not advance.

THER INLK Indicator (Thermal): This indicator lights when either the chain motor or hammer unit thermal has operated because of an over-heated condition. This condition prevents the controller from becoming Ready.

HS START Indicator (High Speed): This indicator lights when the high-speed start magnet is energized.

LS START Indicator (Low Speed): This indicator lights when the low-speed start magnet is energized.

HS STOP Indicator (High Speed): This indicator lights when the high-speed stop magnet is energized.

LS STOP Indicator (Low Speed): This indicator lights when the low-speed stop magnet is energized.

OPERATION

The following provides information for preparation, operation, and shutdown of the printer subsystem. It also provides information for installing the forms (print paper) installing the carriage control tape, installing the train assembly, and punching the carriage control tape.

SUBSYSTEM PREPARATION

Perform the following steps in preparation for a Print operation:

- 1) Install the print paper according to the Installing Forms Procedure located in this section.
- 2) Install the carriage control tape according to the Installing the Carriage Control Tape Procedure located in this section. (If a new carriage control tape is required, punch the tape according to the Carriage Control Tape Punching Procedure.)
- 3) Make sure that the train assembly in the printer is compatible with the translator matrixes and the setting of the TRAIN SELECTOR switch on the controller. (If a new train assembly is required, install the assembly according to the Installing the Train Assembly procedure.)
- 4) Press the PRINTER ON indicator switch on the controller. The PRINTER ON indicator switch and the HS STOP and LS STOP indicators on the printer shall be on.

If print paper or a carriage control tape was installed, proceed to step 5; if not, proceed to step 7.

- 5) Press the CARRIAGE RESTORE switch on the printer or the controller.
- 6) Set the feed clutch to the desired line density position (six or eight lines per inch). Close the printer cover.
- 7) Set the Equipment Number switch on the controller to the desired position.
- 8) Press the START switch on the printer or the START indicator switch on the controller. The PRINT READY indicator on the printer and the START indicator switch on the controller will light.

The printer is now ready for printing under control of the computer and the controller.

SYSTEM OPERATION

After the preparation procedures are completed, the computer-controlled printing operation normally continues until completion without error and without stopping.

There are certain error conditions that may occur and which light indicators on the printer and the controller, activate appropriate status bits, and which may stop the printer. If an error condition occurs which does not stop the printer, the operator may permit continued operation with the possibility of error in the printing operation.

When a stop-printer error condition occurs while the printer is printing a line or advancing paper, the operation is normally completed before the printer stops.

If the printer stops, the operator normally corrects the condition and then restarts the computer-controlled operation at the point at which it stopped. A power failure requires that the condition be corrected and the Print operation be restarted at the beginning.

Some of the conditions which cause the printer to stop and their remedies are as follows:

- 1) **Printer Out of Paper:** The END OF FORMS indicator lights and the PRINT READY indicator goes out on the printer. The indicator portion of the START indicator switch on the controller goes out. Paper Out and Not Ready status signals become available to the computer.

Remedy: Replenish the paper supply in the printer. The END OF FORMS indicator goes out. Press the START indicator switch on the controller or the START switch on the printer. The indicator portion of the START indicator switch and the PRINT READY indicator light. The Paper Out and Not Ready status signals drop. (If printing to the bottom of the last form is desired, press the SINGLE CYCLE switch on the printer or controller for each additional line to be printed.)

- 2) **Paper Jam or Paper Tear:** Paper advance stops. The FORMS CHECK indicator lights and the PRINT READY indicator on the printer goes out. The indicator portion of the START indicator switch on the controller goes out. A Not Ready status signal also becomes available to the computer.

Remedy: Clear the paper jam or paper tear in the printer. Install new forms. Press the CHECK RESET switch on the printer. The FORMS CHECK indicator on the printer goes out. Press the START indicator switch on the controller or the START switch on the printer. The indicator portion of the START indicator switch and the PRINT READY indicator light. The Not Ready status signal drops.

- 3) **Carriage Control Tape Breaks:** The PRINT READY indicator on the printer goes out and the indicator portion of the START indicator switch on the controller goes out. A Not Ready status signal becomes available to the computer.

Remedy: Prepare a new tape according to the Carriage Control Tape Punching Procedure in this section and install it in the printer. Press the START indicator switch on the controller or the START switch on the printer. The indicator portion of the START indicator switch and the PRINT READY indicator light. The Not Ready status signal drops.

- 4) **Power Failure (400-hertz):** All printer and controller operations stop.

Remedy: The operator should not attempt repair. Competent maintenance personnel should be notified of the malfunction.

- 5) **Power Failure (60-hertz):** All printer and controller operations stop.

Remedy: The operator should not attempt repair. Competent maintenance personnel should be notified of the malfunction.

- 6) **Sync Error While Printing:** The SYNC CHECK indicator on the printer and the SYNC ERROR indicator on the controller light. The PRINT CHECK indicator on the printer and the PRINT ERROR indicator on the controller light at the completion of the line being printed. A Print Error status signal becomes available to the computer.

Remedy: Press the CHECK RESET switch on the printer. All the indicators listed above in this step go out. The Print Error status signal drops. If the indicators remain on, shut down the system. Replace the inked printing ribbon if it appears worn and frayed, thoroughly clean the train (or chain) assembly with a vacuum cleaner, and restart the program. If the Sync Error condition still exists, resynchronization of the position counter of the controller and the train (or chain) assembly by qualified maintenance personnel is required.

- 7) **Sync Error While Not Printing:** The SYNC CHECK indicator on the printer and the SYNC ERROR indicator on the controller flash on and off.

Remedy: Same as for Sync Error While Printing.

- 8) Data Transmission Parity Error When the ERROR OVERRIDE Switch on the Controller is Off: The red indicator in the Equipment Number switch lights. Further printing is inhibited until the condition is corrected.

Remedy: Perform any of the following: 1) a Clear Channel instruction or a Master Clear may be executed, 2) the Release and Disconnect instruction may be issued, 3) the START indicator switch followed by the STOP switch may be pressed on the controller, 4) the ERROR OVERRIDE switch may be pressed on the controller.

SUBSYSTEM SHUTDOWN

Press the controller PRINTER OFF switch and then remove power to the printer.

PRINTER PREPARATION PROCEDURES

The following procedures provide instructions for installing forms (print paper), carriage control tapes, and train assemblies.

Installing Forms

Observe the following procedure when installing forms in the printer. Refer to Figures D-4, D-5, D-8, and D-9 for the physical location of the printer components specified in the procedure.

- 1) Raise the counterbalanced cover of the printer to gain access to the print and forms area.
- 2) Turn the feed clutch knob to a disengaged position (neutral).
- 3) Use the print unit release lever to unlock and swing back the print unit.
- 4) Open the upper and lower forms tractors.
- 5) Set the left forms tractors slightly to the left of the first unit position by pulling up or down on the tractor lock (upper and lower tractor).
- 6) Insert the form on the tractor pins and close the tractor cover.
- 7) Pull out on the right tractor pin and move the tractor to the proper location to line up the right side of the form. The pin should latch in one of the recesses in the tractor slide bar.
- 8) Insert the form on the tractor pins and close the tractor cover.

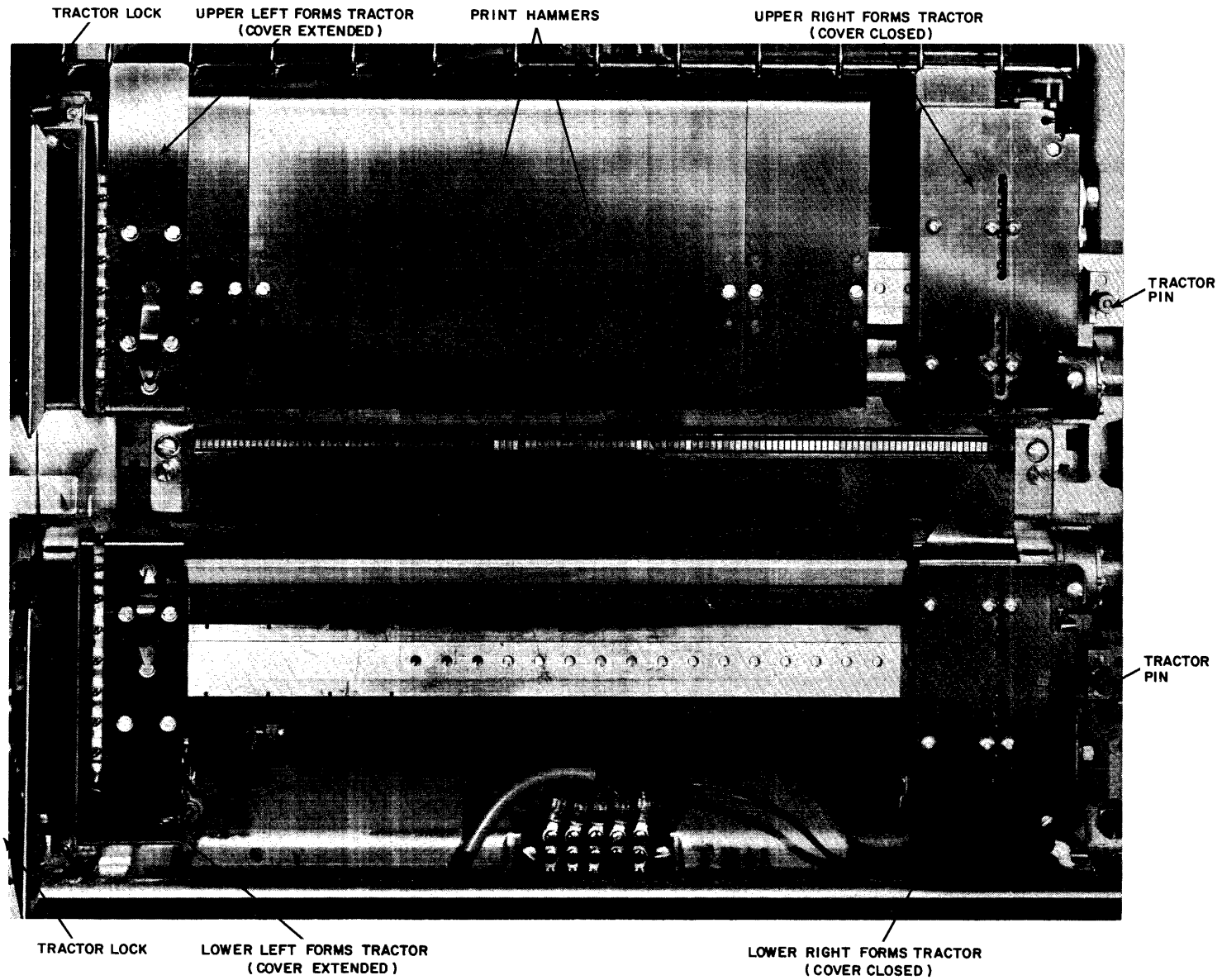

Figure D-8. Forms Tractor Mechanism (Mod 2 Printer)

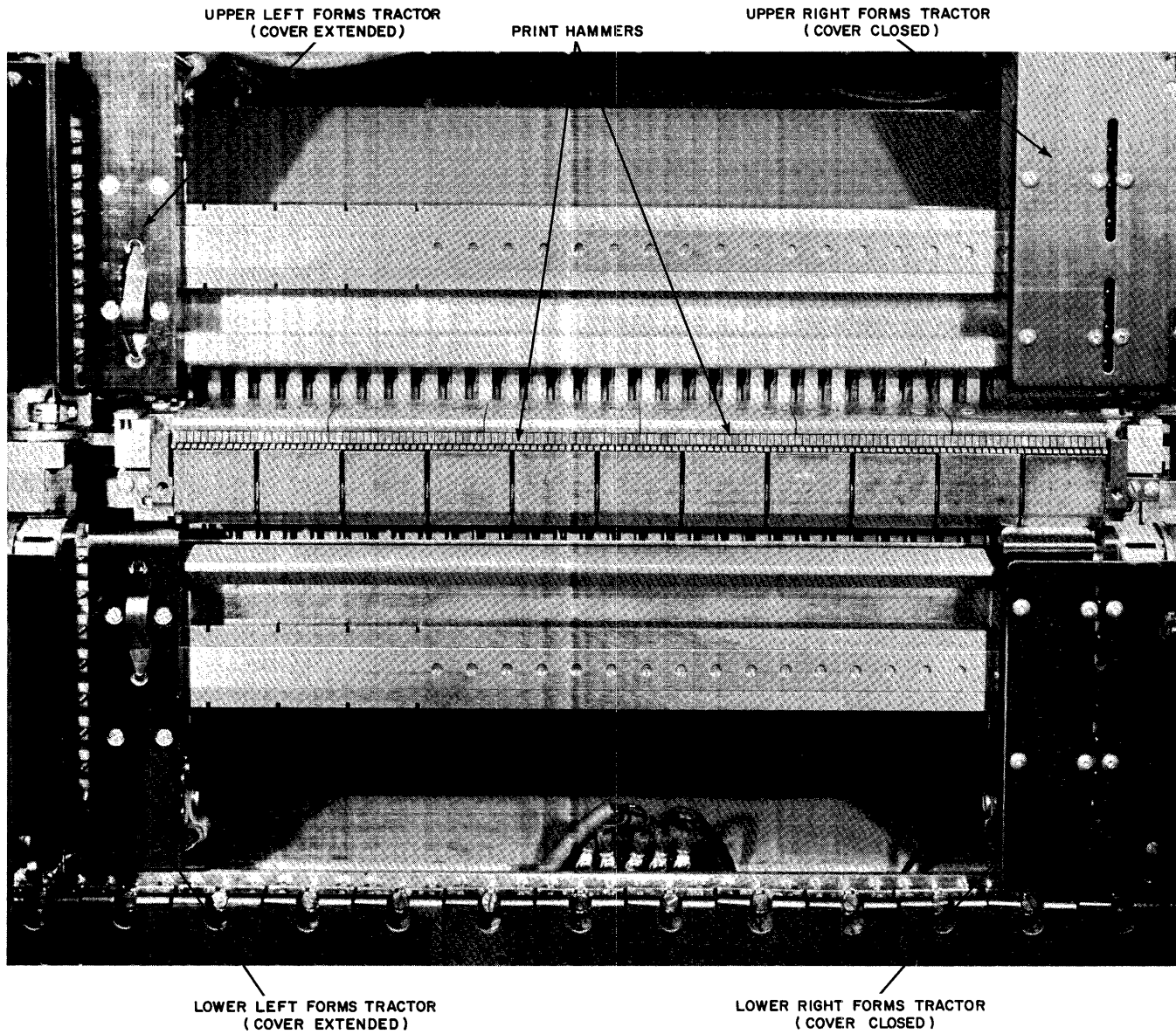

Figure D-9. Forms Tractor Mechanism (Mod 3 Printer)

D-29

3458
Rev F

- 9) Use the RH tractor vernier knob to increase the tension on the form. (Use this knob for adjustments of up to 1/2 inch.)
- 10) Check the position and line where printing will occur by swinging the ribbon shield against the form which is marked with each print position. If the horizontal alignment is not correct, adjust it with the lateral print adjustment lever. Use the lateral print vernier knob for fine adjustment. If the vertical alignment is not correct, adjust it with either the paper advance knob or the vertical print adjustment knob.
- 11) Return the print unit to its normal position and lock it in place. Perform steps 12, 13, and 14 after power is applied to the printer subsystem.
- 12) Restore the carriage control tape to the first printing position by pressing the CARRIAGE RESTORE switch.
- 13) Return the feed clutch knob to a line density position of either six or eight lines per inch, depending on the form to be printed.
- 14) Close the outside cover of the printer.

Installing the Carriage Control Tape

Observe the following procedure when installing a carriage control tape in the printer. Refer to Figures D-4, D-5, and D-10 for the physical location of the printer components specified in the procedure.

- 1) Raise the counterbalanced cover of the printer to gain access to the carriage control tape reading mechanism.
- 2) Turn the feed clutch knob to a disengaged position (neutral).
- 3) Raise the brush assembly by moving the latch located on the side of the brush holder to the left.
- 4) Place one end of the carriage control tape loop, held so that the printed captions can be read, over the pin-feed drive wheel so that the pins engage the center drive holes.
- 5) Place the opposite end of the loop around the adjustable carriage control tape idler.
- 6) Remove the excess slack from the carriage control tape by loosening the locking knob on the idler and moving the idler in its track. Tighten the knob when the desired tension is reached. (The carriage control tape tension should be such that the tape gives slightly when the top and bottom portions of the loop are pressed toward each other. Too much tape tension causes damage to the pin-feed holes.)

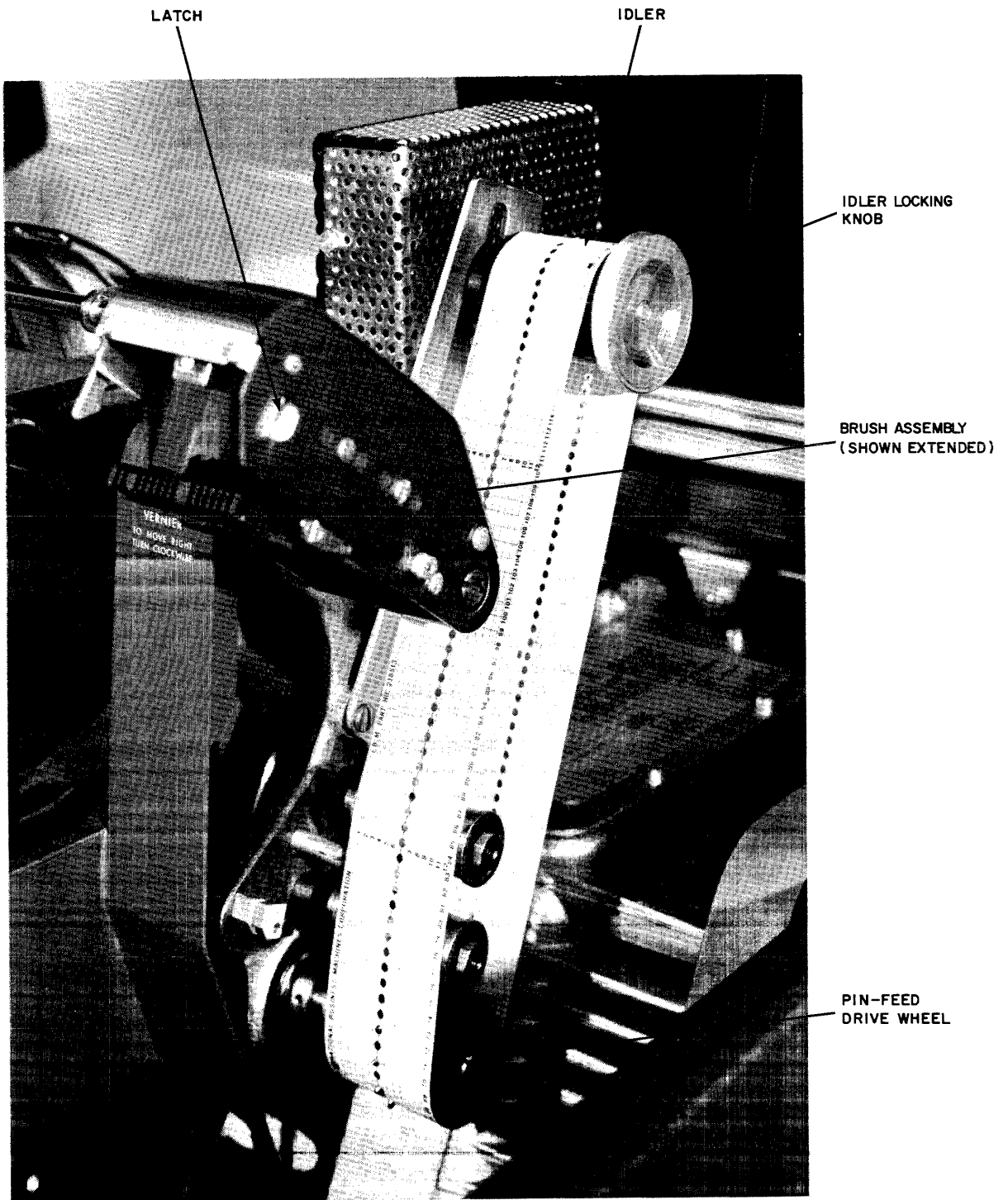

1823

Figure D-10. Carriage Control Tape Mechanism

- 7) Press the brush assembly down until it latches. Perform steps 8, 9, and 10 after power is applied to the printer subsystem.
- 8) Restore the carriage control tape to the first printing position by pressing the CARRIAGE RESTORE switch.
- 9) Return the feed clutch knob to a line density position of either six or eight lines per inch, depending on the form to be printed.
- 10) Close the outside cover of the printer.

Installing the Train Assembly

Observe the following procedure when installing a train assembly in the printer. Refer to Figures D-4, D-5, and D-11 for the physical location of the printer components specified in the procedure.

- 1) Raise the counterbalanced cover of the printer.
- 2) Turn the feed clutch knob to a disengaged position (neutral).
- 3) Unlock and swing back the print unit by using the print unit release lever.
- 4) Tip the ribbon cover down.
- 5) Unlatch and swing the ribbon shield away from the ribbon and the train assembly.
- 6) Unfasten the upper ribbon roll and place it clear of the train assembly.
- 7) Lift the cartridge latch handles on each end of the train assembly and use these handles to lift the assembly clear of the print unit.
- 8) On the 48 character-set train assembly, rotate the timing disk until its key aligns with the stationary side slot.
- 9) On the 60 or 64 character-set train assembly, rotate the timing disk until its key aligns with the stationary side slot and a screw head appears under the viewing window. This is illustrated on the underside of the ribbon cover. Use the special tool attached to the print unit to make this adjustment.
- 10) On the 48 character-set train assembly, rotate the drive gear on the train assembly until a "1" aligns with the marking arrow. Refer to the illustration on the ribbon cover. This adjustment on the 60 or 64 character-set train assembly requires alignment of the "marked 1" with the arrow using the special tool.
- 11) Place and latch the train assembly into its position on the print unit.
- 12) Replace the upper ribbon roll.

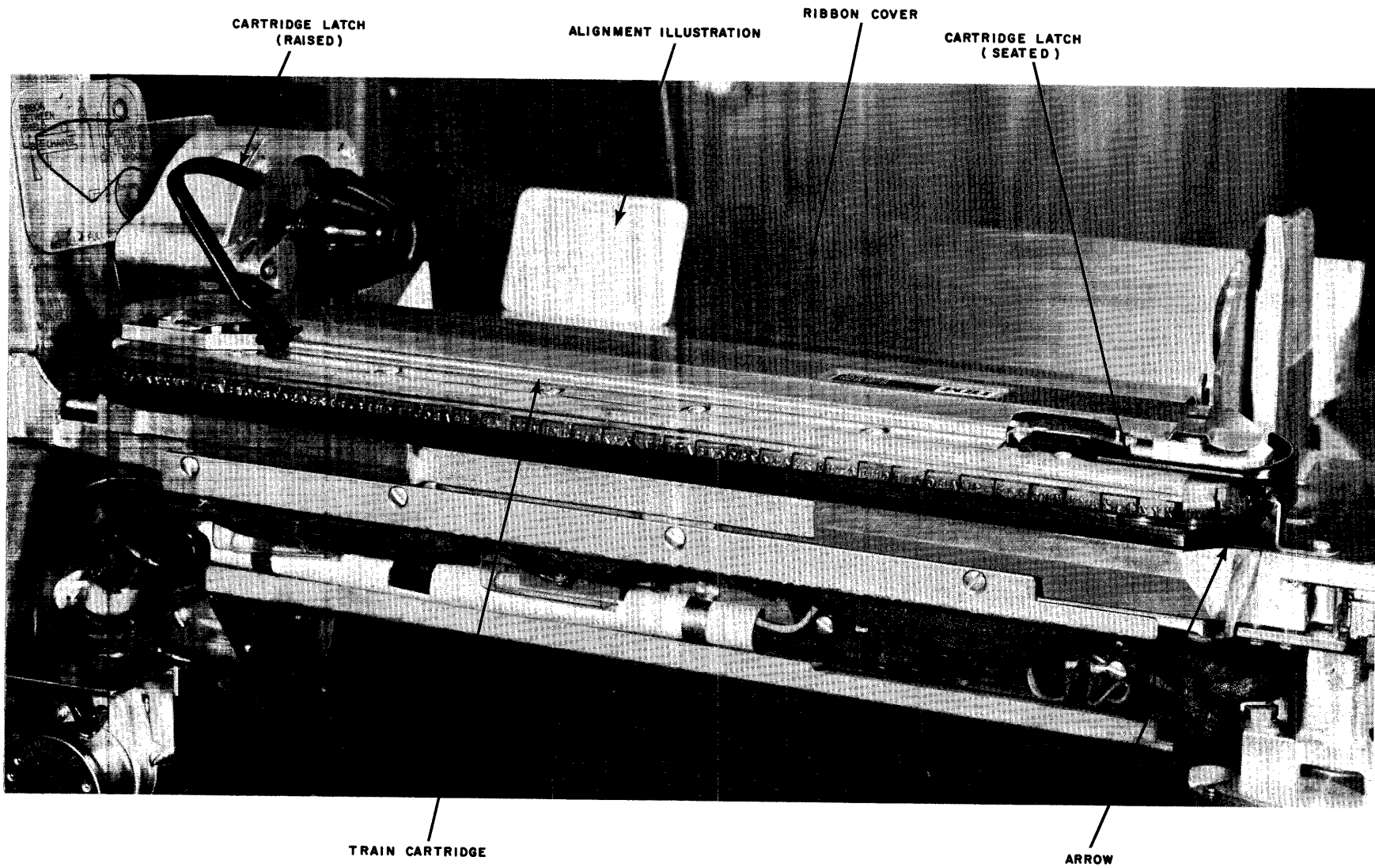

D-33

3458
Rev F

Figure D-11. Train Assembly (Mod 3 Printer)

- 13) Relatch the ribbon shield.
- 14) Return the print unit to its normal position and lock it in place.
- 15) Return the feed clutch knob to the engaged position.
- 16) Close the ribbon cover and the outside cover of the printer.
- 17) Replace the translator matrixes in the controller with a set of matrixes compatible with the new train assembly.

CARRIAGE CONTROL TAPE PUNCHING PROCEDURE

The operator may punch a new carriage control tape when a different printout format is desired or when a tape wears out.

Perform the following procedure when punching a new carriage control tape:

- 1) Lay the length of new tape beside the left edge of the print paper (form) it is to control. Place the top line of the tape (immediately under the glue portion) even with the top edge of the form.
- 2) Place a mark on the tape at the intersection of the first channel and the line that corresponds to the first printing line of the form.
- 3) Place a mark at the intersection of the twelfth channel and the line that corresponds to the last printing line of the form.
- 4) Place marks on the other channels corresponding to the desired high-speed spacing (skip) stops. Do not place marks on the same channel closer than eight spaces. Holes must not be punched in all 12 channels of the same line.
- 5) Repeat the markings of the first form as many times as the usable length of the tape (22 inches) allows.
- 6) Mark the line corresponding to the bottom edge of the last form. This should be at least four lines down from the last channel 12 marking to allow for splicing.
- 7) Insert the tape in the tape punch (Program Tape Punch No. 120910 or equivalent) and align a marked tape line with the guide line on the punch base, placing the center feed holes of the tape over the pins projecting from the punch base.
- 8) Position the punch dial to the number on the punch corresponding to the number of the channel to be punched.
- 9) Press the top of the punch to cut a rectangular hole at the intersection of the selected channel and the marked line on the tape.

- 10) Repeat steps 7, 8, and 9 for each marked line on the tape.
- 11) Cut the tape along the line marked in step 6.
- 12) Remove the glaze from the portion of the tape ends that will overlap, when glued, with an ink eraser.
- 13) Form the tape into a loop and glue the bottom end (marked GLUE) to the top section. Make sure that the cut edge aligns with the line on the top of the tape and that the center feed holes coincide.

PROGRAMMING

The following provides a description of the codes used to communicate between the computer and the printer subsystem, methods of error checking the printer subsystem, general programming considerations, and a programming example.

CONNECT

The controller must be connected to the computer before it can respond to a function instruction, a Write instruction, or a status request from the computer. The connection is accomplished by the connect instruction with the Connect code (N000) in the lower 12 bits of the instruction. The controller connects and returns a Reply to the data channel if:

- 1) The N portion of the Connect code matches the setting of the controller Equipment Number switch, and
- 2) A transmission parity error is not detected.

If a transmission parity error in the Connect code occurs while the controller is connected, the controller disconnects.

FUNCTION CODES

Function codes condition the controller to perform certain operations in controlling the printer. They have no effect on an unconnected controller. The function code is contained in the lower 12 bits of a function instruction and is transmitted to the controller on 12 data lines.

Each function code may be classified as either operating or nonoperating. An operating function code is accepted when the controller is Ready and Not Busy; a nonoperating code is accepted by the connected controller at any time.

The controller examines only one function code at a time. It first checks the code for a transmission parity error. If none exist, if the function code is legal, and if the request can be performed, the controller returns a Reply signal to the computer. If the code is illegal (not defined) or cannot be performed, the controller returns a Reject signal to the computer.

If a transmission parity error is detected, the requested function is not performed, a Transmission Parity Error signal is returned to the computer, and a red indicator in the Equipment Number switch lights.

Refer to Table D-3 for a list of the function codes. A detailed description of each code follows the table.

TABLE D-3. FUNCTION CODES

TITLE	CODE
Release and Disconnect	0000
Single Space	0001
Double Space	0002
Advance to Last Line	0003
Page Eject	0004
Advance to Last Line	0003
Page Eject	0004
Auto Page Eject	0005
Suppress Space	0006
Select Interrupt on Ready and Not Busy	0020
Clear Interrupt on Ready and Not Busy	0021
Select Interrupt on End of Operation	0022
Clear Interrupt on End of Operation	0023
Select Interrupt on Abnormal End of Operation	0024
Clear Interrupt on Abnormal End of Operation	0025
Postprint Spacing Mode (or Clear Carriage Selections)	0030
Select Carriage Tape Level 1 for Postprint Line Spacing	0031
Select Carriage Tape Level 2 for Postprint Line Spacing	0032
Select Carriage Tape Level 3 for Postprint Line Spacing	0033
Select Carriage Tape Level 4 for Postprint Line Spacing	0034
Select Carriage Tape Level 5 for Postprint Line Spacing	0035
Select Carriage Tape Level 6 for Postprint Line Spacing	0036
Select Carriage Tape Level 7 for Postprint Line Spacing	0037
Select Carriage Tape Level 8 for Postprint Line Spacing	0040
Select Carriage Tape Level 9 for Postprint Line Spacing	0041
Select Carriage Tape Level 10 for Postprint Line Spacing	0042
Select Carriage Tape Level 11 for Postprint Line Spacing	0043
Select Carriage Tape Level 12 for Postprint Line Spacing	0044
Preprint Spacing Mode	0050
Select Carriage Tape Level 1 for Preprint Line Spacing	0051
Select Carriage Tape Level 2 for Preprint Line Spacing	0052

TABLE D-3. FUNCTION CODES (Cont'd)

TITLE	CODE
Select Carriage Tape Level 3 for Preprint Line Spacing	0053
Select Carriage Tape Level 4 for Preprint Line Spacing	0054
Select Carriage Tape Level 5 for Preprint Line Spacing	0055
Select Carriage Tape Level 6 for Preprint Line Spacing	0056
Select Carriage Tape Level 7 for Preprint Line Spacing	0057
Select Carriage Tape Level 8 for Preprint Line Spacing	0060
Select Carriage Tape Level 9 for Preprint Line Spacing	0061
Select Carriage Tape Level 10 for Preprint Line Spacing	0062
Select Carriage Tape Level 11 for Preprint Line Spacing	0063
Select Carriage Tape Level 12 for Preprint Line Spacing	0064

Release and Disconnect (0000)

This code clears the existing connect, interrupt selections, and a transmission parity error or program error indication. It is recognized and replied to immediately upon receipt by the controller.

Single Space (0001)

This code causes paper to advance one line in the printer.

Double Space (0002)

This code causes paper to advance two lines to the printer.

Advance to Last Line (0003)

This code advances paper until a hole is detected in carriage control tape level twelve. The last line of the form that may be printed should then be in position for printing. This does not clear postprint spacing selections. It is self-clearing.

Page Eject (0004)

This code advances paper until a hole is detected in carriage control tape level one. The first line of the new form to be printed should then be in position for printing. This code does not clear postprint spacing selections. It is self-clearing.

Auto Page Eject (0005)

This code sets up conditions so that paper automatically spaces from the last line of the form (level 12) to the top of the next form (level 1) the next time level 12 is detected. Actual spacing to the top of the form is accomplished when any paper motion spaces beyond level 12.

Suppress Space (0006)

This code suppresses the next postprint spacing operation and is self-clearing.

Select Interrupt on Ready and Not Busy (0020)

This code causes the controller to send an Interrupt signal to the computer when the printer subsystem is Ready and Not Busy (i. e., power is applied, interlocks are closed, paper is in position, etc). This interrupt is used when operator intervention is required.

The controller accepts and replies to this code on receipt. Once up, the Interrupt signal remains up until cleared by reselection of this interrupt or by selection of Release and Disconnect (0000), Clear Interrupt on Ready and Not Busy (0021), a Clear Channel instruction, or a Master Clear.

Clear Interrupt on Ready and Not Busy (0021)

This code clears a Select Interrupt on Ready and Not Busy function and the Ready and Not Busy Interrupt signal to the computer. The controller accepts and replies to this code on receipt.

Select Interrupt on End of Operation (0022)

This code causes the controller to send an Interrupt signal to the computer after completion of any preprint paper motion if memory has not been reloaded. If memory is loaded during preprint paper motion, an Interrupt signal is returned following printing of the data. During chaining, the interrupt signal is returned at end of chaining operation.

The controller accepts and replies to this code on receipt. Once up, the Interrupt signal remains up until cleared by reselection of this interrupt, by selection of Clear Interrupt on End of Operation (0023) or Release and Disconnect (0000), or on receipt of a Clear Channel instruction or a Master Clear.

Clear Interrupt on End of Operation (0023)

This code clears a Select Interrupt on End of Operation function and the End of Operation Interrupt signal to the computer. The controller accepts and replies to this code on receipt.

Select Interrupt on Abnormal End of Operation (0024)

This code causes the controller to send an Interrupt signal to the computer when any one of the following conditions exists:

- 1) The printer subsystem is Not Ready after a paper motion is completed.
- 2) The printer subsystem is Not Ready after a line of data is printed.
- 3) There is a print error and the ERROR OVERRIDE switch is off after printing a line of data.

The controller accepts and replies to this code on receipt. Once up, the Interrupt signal remains up until cleared by reselection of this interrupt (0024), by selection of Clear Interrupt on Abnormal End of Operation (0025) or Release and Disconnect (0000), or on receipt of a Clear Channel instruction or a Master Clear.

Clear Interrupt on Abnormal End of Operation (0025)

This code clears a Select Interrupt on Abnormal End of Operation function and the Abnormal End of Operation Interrupt signal to the computer. The controller accepts and replies to this code upon receipt.

Postprint Spacing Mode (or Clear Carriage Selections) (0030)

This code places the printer subsystem in a postprint spacing mode so that paper single spaces automatically after each line is printed. It clears all carriage selection, automatic page eject, and suppress space conditions.

Select Carriage Tape Level 1 for Postprint Line Spacing (0031)

Select Carriage Tape Level 2 for Postprint Line Spacing (0032)

Select Carriage Tape Level 3 for Postprint Line Spacing (0033)

Select Carriage Tape Level 4 for Postprint Line Spacing (0034)

Select Carriage Tape Level 5 for Postprint Line Spacing (0035)

Select Carriage Tape Level 6 for Postprint Line Spacing (0036)

Select Carriage Tape Level 7 for Postprint Line Spacing (0037)

Select Carriage Tape Level 8 for Postprint Line Spacing (0040)

Select Carriage Tape Level 9 for Postprint Line Spacing (0041)

Select Carriage Tape Level 10 for Postprint Line Spacing (0042)

Select Carriage Tape Level 11 for Postprint Line Spacing (0043)

Select Carriage Tape Level 12 for Postprint Line Spacing (0044)

These codes cause automatic advancement of paper following each Print operation unless inhibited by a Suppress Space function. Advancement continues until a hole is detected in the selected level. The condition clears as soon as paper motion stops. Carriage control tape level 1 corresponds to the top of the form. Carriage control tape level 12 corresponds to the last line of the form.

Preprint Spacing Mode (0050)

This code places the printer subsystem in a preprint spacing mode. It does not initiate paper motion and it suppresses automatic single space paper motion until cleared by any postprint spacing function code, (including the Postprint Spacing Mode, 0030), Clear Channel instruction, or a Master Clear.

Select Carriage Tape Level 1 for Preprint Line Spacing (0051)

Select Carriage Tape Level 2 for Preprint Line Spacing (0052)

Select Carriage Tape Level 3 for Preprint Line Spacing (0053)

Select Carriage Tape Level 4 for Preprint Line Spacing (0054)

Select Carriage Tape Level 5 for Preprint Line Spacing (0055)

Select Carriage Tape Level 6 for Preprint Line Spacing (0056)

Select Carriage Tape Level 7 for Preprint Line Spacing (0057)

Select Carriage Tape Level 8 for Preprint Line Spacing (0060)

Select Carriage Tape Level 9 for Preprint Line Spacing (0061)

Select Carriage Tape Level 10 for Preprint Line Spacing (0062)

Select Carriage Tape Level 11 for Preprint Line Spacing (0063)

Select Carriage Tape Level 12 for Preprint Line Spacing (0064)

These codes initiate paper motion, suppress automatic single space, and place the printer subsystem in preprint spacing mode. Paper motion continues until a hole is detected in the selected level. This condition may be cleared by any postprint spacing function code, Clear Channel instruction, or a Master Clear. Carriage control tape level 1 corresponds to the top of the form; tape level 12 corresponds to the last line of the form.

STATUS CODES

Status codes display various operating conditions within the controller and the printer to the computer. The computer may request a status code from the connected controller. If two or more operating conditions exist simultaneously, the status code is the sum of the individual codes representing the operating conditions.

Refer to Table D-4 for a list of the status codes. A detailed description of each code follows the table.

TABLE D-4. STATUS CODES

TITLE	CODE
Ready	XXX1
Busy	XXX2
Program Error	XXX4
Paper Out	XX1X
Last Line on Form	XX2X
Carriage Control Tape Level 9	XX4X
Memory Busy	X1XX
Interrupt on Ready and Not Busy	X2XX
Interrupt on End of Operation	X4XX
Interrupt on Abnormal End of Operation	1XXX
Print Error	2XXX

Ready (XXX1) - Bit 0

The printer subsystem becomes Ready when the START switch is pressed on the 3458 or the printer if all of the following conditions are present:

- 1) All power supply voltages are present at the printer.
- 2) All interlocks are closed on the printer.
- 3) The format tape is installed.
- 4) The print paper is installed in the printer.

A Ready status must be established before a line prints or a paper spacing function code is accepted. It remains up until any of the above conditions drop or until the STOP switch is pressed on the 3458 or the printer.

Busy (XXX2) - Bit 1

The printer subsystem becomes Busy when a Write operation is initiated or when the printer moves paper. A Busy status remains up during a Write operation, during a print cycle, or while paper is moving in the printer.

Program Error (XXX4) - Bit 2

This status bit indicates that the translated position code of an incoming illegal BCD character has been loaded into buffer memory.

The Program Error status condition clears prior to the loading of a new line of data into the controller buffer memory and upon receipt of a Release and Disconnect function, a Clear Channel instruction, or a Master Clear.

Paper Out (XX1X) - Bit 3

This status bit indicates that the printer is out of paper.

Last Line on Form (XX2X) - Bit 4

This status bit indicates that the print position of the paper is opposite carriage control tape level 12 (last line of the form). It clears upon initiation of additional paper motion.

Carriage Control Tape Level 9 (XX4X) - Bit 5

This status bit indicates that the print position of the paper is opposite carriage control tape level 9. It clears upon initiation of additional paper motion.

Memory Busy (X1XX) - Bit 6

This status bit indicates that the controller buffer memory is being loaded and it remains up until the line is printed.

Interrupt on Ready and Not Busy (X2XX) - Bit 7

This status bit indicates that Interrupt on Ready and Not Busy was selected and that this condition now exists.

Interrupt on End of Operation (X4XX) - Bit 8

This status bit indicates that Interrupt on End of Operation was selected and that computer-initiated paper motion was completed or, if the controller memory is loaded during this paper motion, the Print operation was completed.

Interrupt on Abnormal End of Operation (1XXX) - Bit 9

This status bit indicates that Interrupt on Abnormal End of Operation was selected and that an abnormal condition existed at the end of the operation.

Print Error (2XXX) - Bit 10

This status bit indicates that any one or a combination of the following errors exists in the line just printed:

- 1) A character position code was loaded into buffer memory but the character was not printed.
- 2) A character was printed even though the position code of that character was not loaded into memory.
- 3) There were one or more memory parity errors.
- 4) A given hammer fired more than once during the line printout.
- 5) There was a sync error between the type on the printer train (or chain) assembly and the controller position counter circuitry.

This status bit drops upon receipt of a new Channel Busy signal, when the CHECK RESET switch is pressed on the printer, or upon receipt of a Clear Channel instruction or a Master Clear from the computer.

INTERRUPTS

Interrupts provide a means of attaining optimum utilization of the capabilities of the subsystem. With interrupts selected, the subsystem can interrupt (halt) the main program and initiate an interrupt processing program (see the system reference manual for the addresses applicable to interrupt processing).

A select interrupt function code permits the controller to consider as a group (see description of interrupt function codes in this section) several of the operating conditions which may occur. If a specific interrupt has been selected and if at least one of the conditions specified by it occurs, the controller sends an Interrupt signal to the computer. If the interrupt system in the computer has been set to recognize the interrupt, the main program is interrupted and control is transferred to a specific program address. Status sensing and follow-up operations may follow. Control is returned to the main program by an appropriate Jump instruction located at the close of the interrupt processing program.

If the computer's interrupt system has not been enabled, it is still possible to sense for these conditions via main program instructions in the computer.

Regardless of which of the above actions is followed, the Interrupt signal remains up until cleared by reselection of the interrupt or by selecting Release and Disconnect instruction, a Clear Channel instruction, or a Master Clear. The Interrupt signal is available on the controller interrupt line whether or not the controller is connected.

The 8-position (positions 0 through 7) Equipment Number switch determines the number of the line on which the Interrupt signal is transmitted. For example, if the Equipment Number switch is set at 5, all Interrupt signals coming from the controller are transmitted on interrupt line 5. Since each equipment attached to a data channel must have a unique equipment number, each uses a different interrupt line.

DATA TRANSFER

The computer transfers data to the printer subsystem as 12-bit data words. Each 12-bit data word represents two characters during a 12-bit mode operation (no Suppress Assembly/Disassembly signal at the controller). The character in the upper half of the 12-bit word always prints to the left of the character in the lower half of the word during a 6-bit mode operation (Suppress Assembly/Disassembly signal at the controller). The upper half of this 12-bit data word is not used.

The characters transferred are represented by either internal or external BCD codes. When transferring internal BCD codes, absence of a Negate BCD Conversion signal at the controller allows conversion to external BCD codes.

If the Write signal remains up after a complete line (132 characters) is loaded into the controller buffer memory, the controller accepts new data but does not process it. This loss of data continues until the Write signal drops.

Table D-5 lists all the characters and their corresponding internal and external BCD codes needed for an array in a 48 character-set train (or chain) assembly. Tables D-6 and D-7 contain this information for a 60 character-set train assembly and a 64 character-set train assembly, respectively. All three tables are arranged in the sequence in which the characters appear in an array.

All codes not listed in Tables D-5 and D-6 are illegal. They are detected as program errors at the controller and are treated as blank codes. Illegal code detection is unnecessary when using a 64 character-set train assembly because it uses all possible codes.

TABLE D-5. STANDARD 48 CHARACTER-SET

CHARACTER (Array sequence)	EXT BCD Code	INT BCD Code	CHARACTER (Array sequence)	EXT BCD Code	INT BCD Code
1	01	01	J	41	41
2	02	02	K	42	42
3	03	03	L	43	43
4	04	04	M	44	44
5	05	05	N	45	45
6	06	06	O	46	46
7	07	07	P	47	47
8	10	10	Q	50	50
9	11	11	R	51	51
0	12	00	- (minus)	52	52
#	13	13	\$	53	53
@	14	14	*	54	54
/ (slash)	21	61	A	61	21
S	22	62	B	62	22
T	23	63	C	63	23
U	24	64	D	64	24
V	25	65	E	65	25
W	26	66	F	66	26
X	27	67	G	67	27
Y	30	70	H	70	30
Z	31	71	I	71	31
≠	32	72	&	72	32
, (comma)	33	73	. (period)	73	33
%	34	74	⌘	74	34
			Blank	20	60

48 Character-Set ILLEGAL codes (listed in EXT BCD) - 00, 15, 16, 17, 35, 36, 37, 40, 55, 56, 57, 60, 75, 76, and 77.

TABLE D-6, STANDARD 60 CHARACTER-SET

CHARACTER (Array sequence)	EXT BCD Code	INT BCD Code	CHARACTER (Array sequence)	EXT BCD Code	INT BCD Code
1	01	01	P	47	47
2	02	02	Q	50	50
3	03	03	R	51	51
4	04	04	- (minus)	40	40
5	05	05	Z	31	71
6	06	06	(34	74
7	07	07	A	61	21
8	10	10	B	62	22
9	11	11	C	63	23
0	12	00	D	64	24
X	27	67	E	65	25
Y	30	70	F	66	26
/ (slash)	21	61	G	67	27
S	22	62	H	70	30
T	23	63	I	71	31
U	24	64	+	60	20
V	25	65	. (period)	73	33
W	26	66)	74	34
(absolute)	52	52	%	16	16
:	00	12	\$	53	53
_ (underline)	36	76	*	54	54
"	56	56	#	55	55
, (comma)	33	73	&	15	15
=	13	13	@	35	75
J	41	41	<	72	32
K	42	42	;	77	37
L	43	43	¬ (logical NOT)	76	36
M	44	44	'	14	14
N	45	45	?	37	77
O	46	46	>	57	57
			Blank	20	60

60 Character-Set ILLEGAL codes (listed in EXT BCD) - 17, 32, and 75

TABLE D-7. STANDARD 64 CHARACTER-SET

CHARACTER (Array sequence)	EXT BCD Code	INT BCD Code	CHARACTER (Array sequence)	EXT BCD Code	INT BCD Code
1	01	01	Z	31	71
2	02	02	(34	74
3	03	03	A	61	21
4	04	04	B	62	22
5	05	05	C	63	23
6	06	06	D	64	24
7	07	07	E	65	25
8	10	10	F	66	26
9	11	11	G	67	27
0	12	00	H	70	30
X	27	67	I	71	31
Y	30	70	+	60	20
/ (slash)	21	61	. (period)	73	33
S	22	62)	74	34
T	23	63	%	16	16
U	24	64	\$	53	53
V	25	65	*	54	54
W	26	66]	32	72
:	00	12	→	35	75
, (comma)	33	73	↑	55	55
=	13	13	↓	56	56
≠	14	14	>	57	57
≤	15	15	≥	75	35
[17	17	<	72	32
J	41	41	;	77	37
K	42	42	≡ (60th character of 1st array)	36	76
L	43	43	(logical AND; ^ 60th character of 2nd array)	37	77
M	44	44	(logical OR ∨ 60th character of 3rd array)	52	52
N	45	45	(logical NOT; ¬ 60th character of 4th array)	76	36
O	46	46			
P	47	47			
Q	50	50			
R	51	51			
- (minus)	40	40	Blank	20	60

64 Character-Set ILLEGAL codes - None

PARITY CHECKING

Connect codes, function codes, and data codes are transmitted between the computer and the controller in odd parity (the total number of "1" bits transmitted on the 12 data lines and the parity line is odd).

A transmission parity error exists if the total number of "1" bits transmitted is even. This indicates that a bit has been lost or picked up.

Transmission Parity Error in a Connect Code

If a transmission parity error is detected in a Connect code, the controller does not connect and a Reject or a Reply is not returned to the computer. Instead, the red indicator in the controller Equipment Number switch lights. The transmission parity error indication is cleared by a Clear Channel instruction or a Master Clear prior to a new connect attempt. The transmission parity error indication on the controller may also be cleared by pressing the START indicator switch and then the STOP switch on the controller or by pressing the START switch and then the STOP switch on the printer.

Transmission Parity Error in a Function Code

If a transmission parity error is detected in a function code, the requested function is not performed, a Transmission Parity Error signal is returned to the computer, and the red indicator in the controller Equipment Number switch lights. The transmission parity error indication is cleared by a Clear Channel instruction, a Release and Disconnect instruction, or a Master Clear prior to a new connect attempt. The transmission parity error indication may also be cleared by pressing the START indicator switch and then the STOP switch on the controller or by pressing the START switch and then the STOP switch on the printer.

Transmission Parity Error in a Data Code

If a transmission parity error is detected during a Write operation, the controller sends both a Reply and a Parity Error signal to the computer and the red indicator in the controller Equipment Number switch lights.

The character position data is stored in controller buffer memory but is not printed. Four options are available at this point.

- 1) A Clear Channel instruction or a Master Clear may be executed.
- 2) The Release and Disconnect instruction may be issued.
- 3) The START indicator switch followed by the STOP switch may be pressed on the controller.
- 4) The ERROR OVERRIDE switch may be pressed on the controller.

If the Clear Channel, Master Clear, or Release and Disconnect is used, the controller must be reconnected, the appropriate function reselected, and the line of data transmitted to the controller a second time.

If the START, STOP, and START switches on the controller are pressed in sequence, the line of data prints until the next transmission parity error is detected.

If the ERROR OVERRIDE switch on the controller is pressed, the line of data prints, with possible error, and new lines print without regard to transmission parity errors.

Any of the above options except pressing the ERROR OVERRIDE switch turns off the parity error indicator on the controller.

EQUIPMENT ERROR CHECKING

The controller detects and displays the presence of the following error types:

- 1) Program Error
- 2) Memory Parity Error
- 3) Print Error
- 4) Sync Error

Program Error

A program error occurs whenever an illegal BCD code is transmitted to the controller. One or more errors light the PROGRAM ERROR indicator and set the appropriate status bit.

Presence of a program error does not halt the Print operation. The PROGRAM ERROR indicator goes out and the Program Error status clears when a new Print operation is initiated or when a Release and Disconnect instruction, a Clear Channel instruction, or a Master Clear is received by the controller.

Memory Parity Error

The controller receives a character code from the computer, translates the code, and generates odd parity before sending the character position code to memory. It checks each code for odd parity as it is read out of memory for printing. Absence of odd parity causes the MEMORY PAR ERR, PRINT ERROR, and the corresponding column indicator to light.

A memory parity error appears as a print error during a status check. All error indications drop when a new Print operation is initiated at the controller, when the CHECK RESET switch is pressed on the printer, or when a Clear Channel instruction or a Master Clear is received by the controller.

Print Error

Each printed line may contain one or more of the following error conditions:

- 1) A character position code was loaded into buffer memory but the character was not printed.
- 2) A character was printed even though the position code of that character was not loaded into memory.
- 3) There were one or more memory parity errors.
- 4) A given hammer fired more than once during the line printout.
- 5) There was a sync error between the type on the printer train (or chain) assembly and the controller position counter circuitry.

On completion of the print cycle, the presence of print errors lights the PRINT ERROR indicator and the column indicators corresponding to the locations of the errors in the line. A status check indicates a Print Error condition and sets the appropriate status bit. All error indications drop when a new Print operation is initiated at the controller, when the CHECK RESET switch is pressed on the printer, or when a Clear Channel instruction or a Master Clear is received by the controller.

Sync Error

Sync error occurs when the printer train (or chain) assembly position and the controller position counter circuitry are not synchronized. Presence of a sync error while printing lights the SYNC CHECK indicator on the printer and the SYNC ERROR indicator on the controller. The PRINT CHECK indicator on the printer and the PRINT ERROR indicator on the controller light at the completion of the line being printed. If a sync error occurs while not printing, the SYNC CHECK indicator and the SYNC ERROR indicator flash on and off.

All error indications drop when a new Print operation is initiated at the controller, the CHECK RESET switch is pressed on the printer, or when a Clear Channel instruction or a Master Clear is received by the controller.

PROGRAMMING CONSIDERATIONS

The following considerations are provided as aids to programming the printer subsystem.

- 1) The printing rate is maintained (up to 132 characters per line) regardless of the line content. One exception is that the printing rate drops for each line that requires the printing of unique characters in the 59 preferred, 4 array train assembly.
- 2) The controller buffer memory can be fully loaded in a maximum of 4 milliseconds depending on the computer used. The controller can accept a 12-bit data word (2 characters - 12-bit mode) every 10.5 usec or a 12-bit data word (1 character - 6-bit mode) every 5.3 usec. These times are measured from the leading edge of the Data signal to the leading edge of the Reply signal.
- 3) The approximate time to print one line and single space is as follows:

Mod 3, 48 character-set train assembly	- 54.5 milliseconds
Mod 3, 60 character-set train assembly	- 63.2 milliseconds
Mod 3, 64 character-set train assembly (When using the 59 preferred characters only)	- 63.2 milliseconds
Mod 3, 64 character-set train assembly (When using all characters)	- 192.8 milliseconds
Mod 2, 48 character-set train assembly	- 100 milliseconds
- 4) If the Release and Disconnect instruction (0000) is received by the controller while a line is being printed, the printing of that line continues to completion.

PROGRAMMING EXAMPLE

The following program executed on a 3200 computer causes the printer subsystem to place 6 lines on two sheets of printer paper as shown in Figure D-12. Note that lines 1, 2, 5, and 6 actually print one space past the detected hole level to place the printed lines in proper position on the printer paper.

Prepare the printer subsystem and clear the controller according to the Preparation Procedures under Operation in this section. Start the program at address 0000.

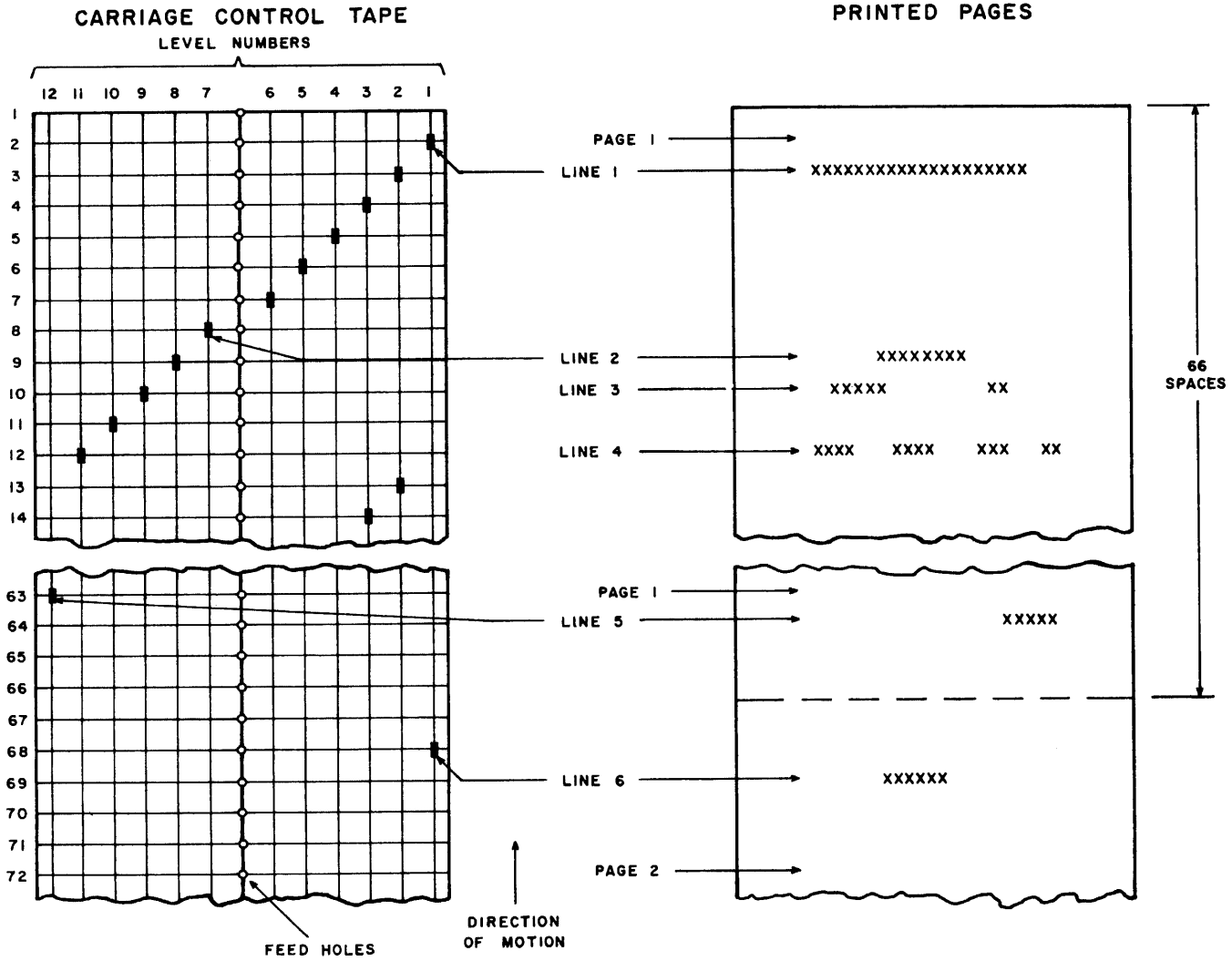

Figure D-12. Spacing Example

LOCATION (NUMERIC)	INSTRUCTION	LOCATION (MNEMONIC)	OPERATION FIELD	ADDRESS FIELD	COMMENTS
0000	77014000				
0001	01000000	START	CON	4000B, 1	CONNECT PRINTER ON CHANNEL=1, EQUIP=4
0002	77210001	NTREADY	UJP	START	
0003	01000005		EXS	1, 1	
0004	01000002		UJP	READY	
0005	77210002	BUSY	UJP	NTREADY	WAIT IF NOT READY
0006	01000005		EXS	2, 1	
0007	77110005	SEL1	UJP	READY	WAIT IF BUSY
0010	01000007		SEL	5, 1	SELECT AUTO PAGE EJECT
0011	77110051	SEL2	UJP	SEL1	
0012	01000011		SEL	51B, 1	SELECT CARRIAGE TAPE LEVEL 1 -- PREPRINT MODE
0013	77110020	SEL3	UJP	SEL2	
0014	01000013		SEL	20B, 1	SELECT INTERRUPT ON READY AND NOT BUSY
0015	77210002	BUSY	UJP	SEL3	
0016	01000015		EXS	2, 1	
0017	77210200	INT	UJP	BUSY	WAIT IF PRINTER BUSY
0020	01000022		EXS	200B, 1	CHECK READY NOT BUSY INTERRUPT
0021	01000017		UJP	SEL4	
0022	77110021	SEL4	UJP	INT	
0023	01000022		SEL	21B, 1	CLEAR INTERRUPT ON READY AND NOT BUSY
0024	77110022	SEL5	UJP	SEL4	
0025	01000024		SEL	22B, 1	SELECT INTERRUPT ON END OF OPERATION
0026	77110037	SEL6	UJP	SEL5	
0027	01000026		SEL	37B, 1	SELECT CARRIAGE TAPE LEVEL 7 -- POSTPRINT MODE
0030	76007040	PRINT1	UJP	SEL6	
0031	10007000		OUTW	1, BUF, BUF+40B	PRINT FIRST LINE
0032	01000030		UJP	PRINT1	
0033	77210400	INT1	EXS	400B, 1	CHECK END OF OPERATION INTERRUPT STATUS
0034	01000036		UJP	BUSY1	
0035	01000033		UJP	INT1	
0036	77210002	BUSY1	EXS	2, 1	
0037	01000036		UJP	BUSY1	WAIT IF PRINTER BUSY
0040	77110022	SEL7	SEL	22B, 1	RESELECT INTERRUPT ON END OF OPERATION
0041	01000040		UJP	SEL7	
0042	76007040	PRINT2	OUTW	1, BUF, BUF+40B	PRINT SECOND LINE
0043	10007000				
0044	01000042		UJP	PRINT2	
0045	77210400	INT2	EXS	400B, 1	CHECK END OF OPERATION INTERRUPT STATUS

LOCATION (NUMERIC)	INSTRUCTION	LOCATION (MNEMONIC)	OPERATION FIELD	ADDRESS FIELD	COMMENTS
0046	01000050		UJP	BUSY2	
0047	01000045		UJP	INT2	
0050	77210002	BUSY2	EXS	2, 1	
0051	01000050		UJP	BUSY2	WAIT IF PRINTER BUSY
0052	77110022	SEL8	SEL	22B, 1	RESELECT INTERRUPT ON END OF OPERATION
0053	01000052		UJP	SEL8	
0054	77110006	SEL9	SEL	6, 1	SELECT SUPPRESS PAPER ADVANCE
0055	01000054		UJP	SEL9	
0056	76007040	PRINT3	OUTW	1, BUF, BUF+40B	PRINT THIRD LINE
0057	10007000				
0060	01000056		UJP	PRINT3	
0061	77210400	INT3	EXS	400B, 1	CHECK END OF OPERATION INTERRUPT STATUS
0062	01000064		UJP	BUSY3	
0063	01000061		UJP	INT3	
0064	77210002	BUSY3	EXS	2, 1	
0065	01000064		UJP	BUSY3	WAIT IF PRINTER BUSY
0066	77110022	SEL10	SEL	22B, 1	SELECT INTERRUPT ON END OF OPERATION
0067	01000066		UJP	SEL10	
0070	17110002	SEL11	SEL	2, 1	SELECT DOUBLE SPACE
0071	01000070		UJP	SEL11	
0072	77210400	INT4	EXS	400B, 1	CHECK END OF OPERATION INTERRUPT STATUS
0073	01000075		UJP	BUSY4	
0074	01000072		UJP	INT4	
0075	77210002	BUSY4	EXS	2, 1	
0076	01000075		UJP	BUSY4	WAIT IF PRINTER BUSY
0077	77110022	SEL12	SEL	22B, 1	RESELECT INTERRUPT ON END OF OPERATION
0100	01000077		UJP	SEL12	
0101	77110044	SEL13	SEL	44B, 1	SELECT CARRIAGE TAPE LEVEL 12 -- POSTPRINT MODE
0102	01000101		UJP	SEL13	
0103	76007040	PRINT4	OUTW	1, BUF, BUF+40B	PRINT FOURTH LINE
0104	10007000				
0105	01000103		UJP	PRINT4	
0106	77210400	INT5	EXS	400B, 1	CHECK END OF OPERATION INTERRUPT STATUS
0107	01000111		UJP	BUSY5	
0110	01000106		UJP	INT5	
0111	77210002	BUSY5	EXS	2, 1	
0112	01000111		UJP	BUSY5	WAIT IF PRINTER BUSY

LOCATION (NUMERIC)	INSTRUCTION	LOCATION (MNEMONIC)	OPERATION FIELD	ADDRESS FIELD	COMMENTS
0113	77110022	SEL14	SEL	22B, 1	RESELECT INTERRUPT ON END OF OPERATION
0114	01000113		UJP	SEL14	
0115	76007040	PRINT5	OUTW	1, BUF, BUF+40B	PRINT FIFTH LINE
0116	10007000				
0117	01000115		UJP	PRINT5	
0120	77210400	INT6	EXS	400B, 1	CHECK END OF OPERATION INTERRUPT STATUS
0121	01000123		UJP	BUSY6	
0122	01000120		UJP	INT6	
0123	77210002	BUSY6	EXS	2, 1	
0124	01000123		UJP	BUSY6	WAIT IF PRINTER BUSY
0125	77110022	SEL15	SEL	22B, 1	RESELECT INTERRUPT ON END OF OPERATION
0126	01000125		UJP	SEL15	
0127	76007040	PRINT6	OUTW	1, BUF, BUF+40B	PRINT SIXTH LINE
0130	10007000				
0131	01000127		UJP	PRINT6	
0132	77210400	INT7	EXS	400B, 1	CHECK END OF OPERATION INTERRUPT STATUS
0133	01000135		UJP	BUSY7	
0134	01000132		UJP	INT7	
0135	77210002	BUSY7	EXS	2, 1	
0136	01000135		UJP	BUSY7	WAIT IF PRINTER BUSY
0137	77110023	SEL16	SEL	23B, 1	CLEAR INTERRUPT ON END OF OPERATION
0140	01000137		UJP	SEL16	

SECTION E

3254-A LINE PRINTER

CONTENTS

Functional Description	E-1	Function Codes	E-7
Print Operation	E-1	Status Codes	E-10
Paper Motion Operation	E-2	Character Codes	E-11
Paper Advance	E-2	Programming Considerations	E-13
Printing Rate	E-3	Printing Speed	E-13
Transmission Parity Checking	E-3	Paper Motion Restrictions	E-13
Legal Code Check	E-4	Manual Operation	E-13
Suppress Assembly/Disassembly	E-4	Switches and Indicators	E-13
Definitions of Conditions	E-5	Format Tape	E-15
Codes	E-6		
Connect Code	E-7		

FIGURES

E-1 Switches and Indicators	E-13	E-2 Format Tape	E-17
-----------------------------	------	-----------------	------

TABLES

E-1 Connect, Function, and Status Codes	E-6	E-2 Standard 64-Character Drum Layout	E-11
---	-----	---------------------------------------	------



3254 LINE PRINTER

3254-A LINE PRINTER

The CONTROL DATA® 3254-A Line Printer consists of a controller and a 300-line-per-minute, 64-character, 136-column, drum-type printer. The printer operates from a single CONTROL DATA® 3000 Series Data Channel or its equivalent. Function codes transmitted via this data channel control paper motion and enable the generation of interrupt signals to the data channel when the specified conditions exist.

This section describes the disassembly of data to be printed, printer paper movement, Connect, function, and status codes, and programming and operating information.

FUNCTIONAL DESCRIPTION**PRINT OPERATION**

The controller disassembles 12-bit data bytes from the data channel into 6-bit BCD codes. In a printed line, the character designated by the upper 6 bits of a byte precedes the character corresponding to the lower 6 bits. Each line of print contains up to 136 characters, so 68 bytes are needed to form a full line. In the 6-bit mode, the controller uses only the lower 6 bits of the 12-bit data byte so the printed line consists of consecutive lower 6-bit characters.

The controller contains a core memory in which it temporarily stores each line of print. After 68 bytes have been received, the controller stops accepting data and begins the actual print operation. After the line has been printed, the controller can store the next line in memory. Paper is spaced automatically at this time unless another spacing operation is programmed.

If the data channel terminates an output operation before a full line is formed, the partial line is printed. If the controller receives a partial line of print (less than 136 characters), the dropping of the Write signal from the data channel causes the remaining positions in memory to be filled with blanks.

The duration of the print operation is defined as the time to complete one or more lines of print, depending on the signals received from the data channel. The print operation

starts when the Channel Busy line from the data channel goes to a "1". The operation is terminated at completion of the line of print after the Channel Busy line goes from a "1" to a "0".

PAPER MOTION OPERATION

A paper motion that is started by an external function code from the data channel is an operation. This is also defined as a computer-initiated paper motion. Single Space, Double Space, Advance to Last Line, Page Eject, and the Preprint Spacing Mode function codes make up this type of paper motion. The automatic space and the postprint paper motions are not considered operations.

PAPER ADVANCE

The printer has a flexible paper-advancing system that is controlled by function codes. Certain function codes, such as Single Space and Double Space, cause spacing operations to occur directly. Other codes control spacing through the printer's format tape reader. If no spacing operations are programmed by means of the function codes, the printer automatically single spaces after each line is printed. The printer contains a 12-level format tape reader of which 8 levels are used. The 8-level format can be used to provide any page format desired. A loop of punched tape is the controlling medium, as loops of various lengths can be used to give different page lengths.

A tape loop contains one frame for each line of the page format. During any spacing operation, the format tape advances one frame each time the paper advances one line. Paper spacing can be programmed to begin automatically after a line is printed or upon receipt of certain function codes. For instructions using the paper tape, the paper (and the tape loop) advances until a hole is detected in a preselected level on the tape.

There are two types of format spacing codes: preprint spacing codes and postprint spacing codes.

A preprint spacing code initiates a one-time spacing operation. An example of these codes is Select Format Tape Level 1 for Preprint Line Spacing (0021). This code causes the paper to advance until a hole is detected in the first level of the tape loop.

Postprint spacing codes set up conditions for automatic spacing operations which occur after each line is printed. These codes remain in effect until cleared. An example of

these codes is Select Format Tape Level 5 for Postprint Line Spacing (0015). When this code is in effect, a spacing operation begins after each line is printed. The paper advances until a hole is detected in the fifth level of the tape loop.

Tape Levels 1 through 6 are used to control preprint and postprint spacing operations. A punch in Level 7 is used to designate the last line of a form. A function code is available that advances the paper to the last line. The top of the form is designated by a punch in Level 8. The printer can be programmed to advance paper until a hole is detected in Level 8.

The section on function codes following Table E-1 describes each of the paper spacing codes. Preparation of the format tape is discussed in the Manual Operation section.

PRINTING RATE

The printing rate is 300 lines per minute. To maintain maximum printing rates, certain programming restrictions must be observed as described in Programming Considerations.

TRANSMISSION PARITY CHECKING

Connect codes, function codes, and all data are checked in the controller for odd parity. A transmission parity error exists if the total number of "1" bits transmitted on the 12 data lines plus the parity line is even, indicating that a bit has been lost or acquired.

Parity Error in the Connect Code

If a parity error is detected in the Connect code, the controller does not connect and the Parity Error indicator will light. If the controller is connected and a parity error is detected in the Connect code to any equipment on the same data channel, the controller disconnects and the Parity Error indicator will light. The parity error can be cleared by a Release and Disconnect instruction, a reconnect, or a Master Clear.

Parity Error in a Function Code

If a parity error is detected in a function code, the controller neither sends a Reply to the data channel nor executes the function. The parity error can be cleared by a Release and Disconnect instruction, a reconnect, or a Master Clear.

Parity Error in Data

If a parity error is detected in a data word, a Parity Error signal is sent to the data channel and the Parity Error indicator will light. The controller replies to the data word containing the parity error and the word is loaded into memory. In its normal mode of operation, the printer does not print out this word. Printout, if required, can be done in one of four ways:

1. Sequentially pressing the STOP and START switches
2. Pressing the PARITY ERR OVERRIDE switch
3. Sending a Release and Disconnect code (0000) to the controller
4. Reconnecting the controller

NOTE

If a printout of data containing the parity error is not required, the Parity Error condition can be cleared using a Master Clear or a Clear Channel. Then the same line or a new line of information may be loaded into memory.

LEGAL CODE CHECK

The controller checks all function codes for legality. Codes other than those listed in Table E-1 are illegal. If the controller detects an illegal code, it sends a Reject signal to the data channel.

SUPPRESS ASSEMBLY/DISASSEMBLY

A 12-bit data word supplies either one or two character codes. A "0" signal on the Suppress Assembly/Disassembly line from the data channel directs the controller to disassemble the 12-bit data word. The printer prints the character represented by the upper 6 bits (bits 06-11) to the left of the character represented by the lower 6 bits (bits 00-05). A "1" signal on the line directs the controller to use only the lower 6 bits.

DEFINITIONS OF CONDITIONS

Ready

Pressing the START switch causes the printer to become Ready if all power supplies are in operation, all fuses are intact, paper is present, the format tape reader interlock is closed, and the drum latch interlock is closed. The printer becomes Not Ready when any one of the above conditions ceases to exist or when the STOP switch is pressed.

Busy

The printer becomes Busy upon the initiation of data transfer to the controller memory or upon the receipt of a function code which initiates paper motion. The printer becomes Not Busy when the Channel Busy line is down and a print operation or paper motion is completed. The loading of the buffer memory does not depend on a Ready condition, and it is, therefore, possible that the printer is Busy and Not Ready. In this case, the memory is loaded and a Not Ready condition prevents printout.

End of Operation

An End of Operation normally occurs at the end of a print operation or a paper motion operation. However, since operations may overlap, it is possible to fill the memory during a paper motion operation. Under this condition, the End of Operation occurs at the end of the last operation initiated. The End of Operation does not always coincide with the transition from Busy to Not Busy. If, for example, postprint spacing is selected, the End of Operation occurs immediately after the printing of the line is completed. However, the printer is Busy until the spacing after the printing is completed. When an Interrupt on End of Operation is selected, the Interrupt signal is sent to the data channel at the end of the last operation initiated.

Abnormal End of Operation

An Abnormal End of Operation takes place if a Not Ready condition exists at the end of a line of print or at the end of any paper motion (including postprint line spacing and automatic line spacing). If Interrupt on Abnormal End of Operation is selected, an interrupt occurs upon detection of the condition stated above.

NOTE

Under certain conditions, the Interrupt signal will not be sent to the data channel. Assume the Interrupt on Abnormal End of Operation is selected and the Out of Paper condition is not detected at the end of paper motion because of switch action and paper conditions. If the memory is loaded and the Not Ready condition (caused by the Out of Paper) inhibits printing, the controller will not send an Interrupt signal until the START switch (single cycle) is pressed.

CODES

Table E-1 lists all codes applicable to the 3254 Line Printer. An explanation of each code follows the table.

TABLE E-1. CONNECT, FUNCTION, AND STATUS CODES

CONNECT	
Connect Printer	N000*
FUNCTION	
Release and Disconnect	0000
Single Space	0001
Double Space	0002
Advance to Last Line	0003
Page Eject	0004
Auto Page Eject	0005
Suppress Space	0006
Clear Format Selections (Postprint Spacing Mode)	0010
Select Format Level 1	0011
Select Format Level 2	0012
Select Format Level 3	0013
Select Format Level 4	0014
Select Format Level 5	0015
Select Format Level 6	0016
} for Postprint Line Spacing	
Preprint Spacing Mode	0020
Select Format Level 1	0021
Select Format Level 2	0022
Select Format Level 3	0023
Select Format Level 4	0024
Select Format Level 5	0025
Select Format Level 6	0026
} for Preprint Line Spacing	
Select Interrupt on Ready and Not Busy	0030
Clear Interrupt on Ready and Not Busy	0031
Select Interrupt on End of Operation	0032
Clear Interrupt on End of Operation	0033
Select Interrupt on Abnormal End of Operation	0034
Clear Interrupt on Abnormal End of Operation	0035
STATUS	
Ready	XXX1
Busy	XXX2
Not Used	XXX4
Paper Fault	XX1X
Last Line of Form	XX2X
Not Used	XX4X
Not Used	X1XX
Ready and Not Busy Interrupt	X2XX
End of Operation Interrupt	X4XX
Abnormal End of Operation Interrupt	1XXX
Not Used	2XXX
Not Used	4XXX
* N = setting of the Equipment Number switch	

CONNECT CODE

Connect Printer (N000)

This code connects the printer to the data channel when the proper conditions are present. The N portion of the code must match the setting of the Equipment Number switch.

FUNCTION CODES

Function codes are used to prepare the connected controller and printer for an output operation. If the printer is connected and the function code does not have a transmission parity error, the controller replies to function codes 0000 and 0020 through 0025. All other function codes require, in addition to the above conditions, that the printer be Ready and Not Busy. If the printer is connected, but the other conditions for the specific codes are not satisfied, the controller sends a Reject signal to the data channel. If an illegal function code (any code not listed in Table E-1) is transmitted, the controller sends a Reject signal to the data channel.

The select interrupt codes (0030, 0032, and 0034) permit the controller to recognize several of the operating conditions which may occur. If a specific interrupt has been selected and if the Interrupt condition occurs, the controller sends an Interrupt signal to the data channel. The Interrupt signal remains up until it is cleared by reselecting the interrupt, a Release and Disconnect code, a clear interrupt code, or a Master Clear. The setting of the Equipment Number switch determines on which line the Interrupt signal will be transmitted to the data channel. Each clear interrupt code (0031, 0033, and 0035) removes the Interrupt signal and selection resulting from its associated select interrupt code.

Release and Disconnect (0000)

This code disconnects the printer from the data channel, clears interrupt selections and responses, and clears a transmission parity error.

Single Space (0001)

This code advances the paper one line. It is self-clearing.

Double Space (0002)

This code advances the paper two lines. It is self-clearing.

Advance to Last Line (0003)

This code spaces the paper until a punched hole is detected in format tape Level 7 (last line of form). It is self-clearing.

Page Eject (0004)

This code advances the paper until a punched hole is detected in Level 8 (top of form). It is self-clearing.

Auto Page Eject (0005)

This code provides automatic line spacing from the last line of the form (Level 7) to the top of the next form (Level 8) the next time the last line of the form (Level 7) is detected. It can be cleared only with a 0010 code or a Master Clear.

If the paper has reached the last line of form (Level 7), any computer-initiated paper motion causes the paper to advance until a hole is detected in Level 8.

If the paper is not at the last line of form and paper motion is initiated that advances paper beyond Level 7, spacing terminates upon detection of a hole in Level 8.

When in the Postprint Spacing mode, spacing begins automatically after completion of print on the last line of the form. Spacing terminates upon detection of a hole in Level 8.

Suppress Space (0006)

This code suppresses the next postprint spacing operation and then clears.

Clear Format Selections (Postprint Spacing Mode) (0010)

This code selects the Postprint Spacing mode. It clears all format selections including Auto Page Eject and Suppress Space. The Postprint Spacing mode is the initial or cleared condition of the printer. In this mode there is an automatic single space after each line is printed.

Select Format Level X for Postprint Line Spacing (001X*)

These codes (0011 through 0016) select format tape levels for postprint line spacing. Spacing starts upon completion of a line of print unless it is inhibited by a Suppress Space code. It terminates when a hole is detected in the selected format level unless modified by an Auto Page Eject condition.

* X designates any one of the 6 lower tape levels.

Preprint Spacing Mode (0020)

This code does not start paper motion but selects the Preprint Spacing mode. When in this mode, the automatic initiation of paper motion (after the print operation) is suppressed. The printer stays in this mode until cleared by a Master Clear, a 0010 function code, or any one of the 0011 through 0016 function codes.

Select Format Level X for Preprint Line Spacing (002X*)

These codes (0021 through 0026), like the 0020 code, select the Preprint Spacing mode. In addition, these codes start paper motion which will terminate when a hole is detected in the format tape level specified by one of codes unless modified by an Auto Page Eject condition.

Select Interrupt on Ready and Not Busy (0030)

An Interrupt signal is generated when a Ready and Not Busy condition exists. Reselection will remove the Interrupt signal resulting from a previous selection.

NOTE

When a Ready and Not Busy condition exists, the Interrupt signal will come up as soon as the Interrupt is selected.

Clear Interrupt on Ready and Not Busy (0031)

This code removes the Interrupt signal and selection resulting from code 0030.

Select Interrupt on End of Operation (0032)

An Interrupt signal is generated upon the completion of the last print or paper motion operation initiated. Reselection will remove the Interrupt signal resulting from a previous selection.

Clear Interrupt on End of Operation (0033)

This code removes the Interrupt signal and selection resulting from code 0032.

Select Interrupt on Adnormal End of Operation (0034)

An Interrupt signal is generated upon the completion of an operation during which an abnormal condition was detected. Reselection will remove the Interrupt signal resulting from a previous selection.

* X designates any one of the 6 lower tape levels.

Clear Interrupt on Abnormal End of Operation (0035)

This code removes the Interrupt signal and selection resulting from code 0034.

STATUS CODES

A 12-bit status word (7 bits are used) is available to the data channel whenever the controller is connected. Each bit in the status word indicates the presence or absence of a condition in the printer such as Busy or Paper Fault, etc. The computer uses Sense Status or Copy Status instructions to check the status word.

Status codes XXX4, XX4X, X1XX, 2XXX, and 4XXX are not used. If two or more status signals are present simultaneously, the resulting status code is the logical sum of the individual status signals.

If the controller is connected, the following status signals are available on the status lines to the data channel.

Ready (XXX1)

This code is present when the printer is Ready. A Ready condition exists when the printer is capable of performing all of its functions.

Busy (XXX2)

This code is present when the printer is Busy. The Busy condition exists upon initiation of data transfer to controller memory or upon the receipt of a function code which initiates paper motion.

Paper Fault (XX1X)

This code indicates that the paper supply is exhausted, a paper tear is detected, or the paper is jammed in the printer.

Last Line of Form (XX2X)

This code indicates that the paper is positioned on the last line of the form. It is present only as long as the paper is on the last line of form position and will go down as soon as the paper moves away from this position. The last line position should be indicated by a punched hole in format tape Level 7.

Ready and Not Busy Interrupt (X2XX)

End of Operation Interrupt (X4XX)

Abnormal End of Operation Interrupt (1XXX)

The presence of any of these codes indicates the condition that has caused an interrupt signal. Anytime an interrupt signal is present, one or more of these status signals will be present.

CHARACTER CODES

The controller accepts character codes in either internal or external BCD. The state of the Negate BCD conversion line from the data channel determines how the controller handles the incoming data. If the line is a "1", the controller treats the character code as external BCD. If the line is a "0", the character code is handled as internal BCD.

Table E-2 shows the printer characters in the order that they appear on the print drum. The external BCD codes of the characters must be arranged around the print drum in ascending order. The character order of the print drum is dictated by the design of the controller logic. The drum characters and their codes are listed starting with a blank, since the character generator in the controller is reset at the time the blank comes around on the print drum. This also gives a mechanical pickup reference point, since the blank corresponds to the missing tooth in the magnetic pickup.

TABLE E-2. STANDARD 64-CHARACTER DRUM LAYOUT

DRUM ROW	CHARACTER	EXTERNAL BCD	INTERNAL BCD
1	␣* (space)	20	60
2	/ (slant)	21	61
3	S	22	62
4	T	23	63
5	U	24	64
6	V	25	65
7	W	26	66
8	X	27	67
9	Y	30	70
10	Z	31	71
11] (closing bracket)	32	72
12	, (comma)	33	73
13	((opening parenthesis)	34	74
14	→ (arrow right)	35	75
15	≡ (identity)	36	76
16	∧ (circumflex)	37	77

*Note: ␣ used for mechanical balance

TABLE E-2. STANDARD 64-CHARACTER DRUM LAYOUT (Cont'd)

DRUM ROW	CHARACTER	EXTERNAL BCD	INTERNAL BCD
17	- (hyphen)	40	40
18	J	41	41
19	K	42	42
20	L	43	43
21	M	44	44
22	N	45	45
23	O	46	46
24	P	47	47
25	Q	50	50
26	R	51	51
27	∨ (logical OR)	52	52
28	\$ (dollar sign)	53	53
29	* (asterisk)	54	54
30	↑ (arrow up)	55	55
31	↓ (arrow down)	56	56
32	> (greater than)	57	57
33	+ (plus)	60	20
34	A	61	21
35	B	62	22
36	C	63	23
37	D	64	64
38	E	65	25
39	F	66	26
40	G	67	27
41	H	70	30
42	I	71	31
43	< (less than)	72	32
44	. (period)	73	33
45) (closing parenthesis)	74	34
46	≥ (greater than/equal to)	75	35
47	⌋ (logical NOT)	76	36
48	; (semicolon)	77	37
49	: (colon)	00	12
50	1	01	01
51	2	02	02
52	3	03	03
53	4	04	04
54	5	05	05
55	6	06	06
56	7	07	07
57	8	10	10
58	9	11	11
59	0 (zero)	12	00
60	= (equals)	13	13
61	≠ (not equal)	14	14
62	≤ (less than/equal to)	15	15
63	% (percent)	16	16
64	[(opening bracket)	17	17

PROGRAMMING CONSIDERATIONS

PRINTING SPEED

The print drum rotates at 360 rpm. With the 64-character set and single spacing, a printing rate of 300 lpm is obtainable. A single-line space requires 25 milliseconds. If multiple spacing is used, the time (T) required to move the paper N lines is:

$$T = 25 + 8.4 (N - 1) \text{ ms}$$

The controller memory can accept a 12-bit data word every 4.8 microseconds. When it operates in 6-bit mode (one character code per 12 bits), it will also accept a 12-bit data word every 4.8 microseconds.

PAPER MOTION RESTRICTIONS

The use of repeated paper motion commands should be avoided since it can cause the paper motion mechanism to heat up, causing the spacing to become erratic. For example, if the program requires that the paper be moved five spaces, one multiple-line space rather than five single spaces should be used.

MANUAL OPERATION

SWITCHES AND INDICATORS

An explanation of the functions of the switches and indicators follows Figure E-1.

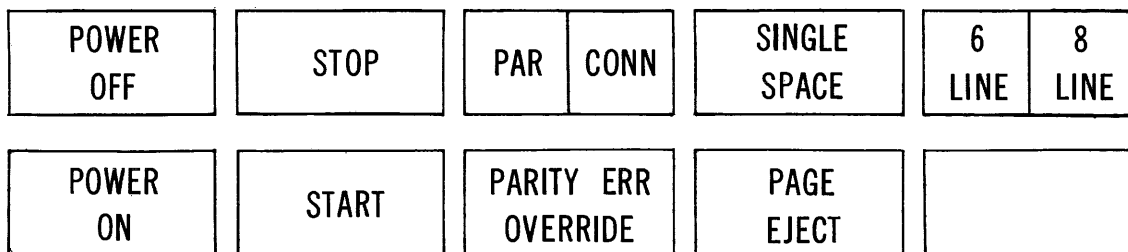

Figure E-1. Switches and Indicators

POWER OFF Switch

Pressing this momentary-contact switch removes ac power from all the power supplies, motors, and fans. It also master clears the controller.

POWER ON Switch and Indicator

Pressing this momentary-contact switch applies ac power to all power supplies, fans, and motors in the proper sequence so that spurious operation of the equipment is prevented. The indicator lights when power is applied to the equipment. Pressing this switch also master clears the controller.

NOTE

Since pressing either the POWER OFF or POWER ON switch will master clear the controller, care should be used to not accidentally press these switches.

STOP Switch and Indicator

Pressing this momentary-push switch causes the printer to become Not Ready and the indicator to light. Consecutively actuating the START and STOP switches clears any Parity Error indications.

START Switch and Ready Indicator

Pressing this momentary-contact switch results in the equipment becoming Ready if the required conditions exist in the printer. When the printer is ready to print, the indicator will light. The indicator will go off if the STOP switch is pressed or if any of the requirements for the Ready condition are not present.

This switch can also be used to initiate a single-cycle operation which allows the printing of one additional line if a Paper Fault condition exists. The switch can be re-pressed until a punched hole is detected in format tape Level 8, top of form. This allows the operator to complete the form which is being printed if the printer stops due to being out of paper (End of Forms). After this, the START switch is disabled until the End of Forms condition is corrected. Pressing this switch with Paper Fault present and not End of Forms will cause the printer to become Ready until the next end of print. Paper Fault also indicates a forms tear or a paper jam as well as End of Forms. When these last conditions are present, the single-cycle operation should not be used.

PAR/CONN Indicator

This is an indicator with a divided lens. If the equipment is connected, the right indicator marked CONN will light. If some type of transmission parity error is detected, the left indicator marked PAR (red light) will light.

PARITY ERR OVERRIDE Switch and Indicator

This is an alternate-action switch and indicator. When the switch is in the override position, the indicator will light and the printing of data in which a transmission parity error was detected will be allowed.

SINGLE SPACE Switch

Pressing this momentary-action switch results in the paper advancing one line.

PAGE EJECT Switch

Pressing this momentary-action switch causes the paper to move to the top of the next form under control of format Level 8.

6 LINE/8 LINE Switch and Indicator

This is an alternate-action switch with a divided lens. The switch allows manual selection of 6- or 8-inch line spacing in the printer and causes the corresponding indicator to light.

Equipment Number Switch

This is an 8-position rotary switch located on the controller logic chassis which is set to indicate the equipment number of the printer. Setting the switch also routes the Interrupt signal from the controller to the data channel.

FORMAT TAPE

The format tape is made of punched Mylar joined in a continuous loop, and it can be up to 22 inches long. This tape contains a number of frames equal to, or a multiple of, the number of lines on the printed page. During any spacing operation, the format tape is advanced one frame each time the paper advances one line.

As shown in Figure E-2, the format tape includes a row of feed holes which engage cogs on a metal drum and drive the tape. Format tape Levels 1 through 8 are monitored by a brush reader assembly, and paper is stopped when the selected level is sensed.

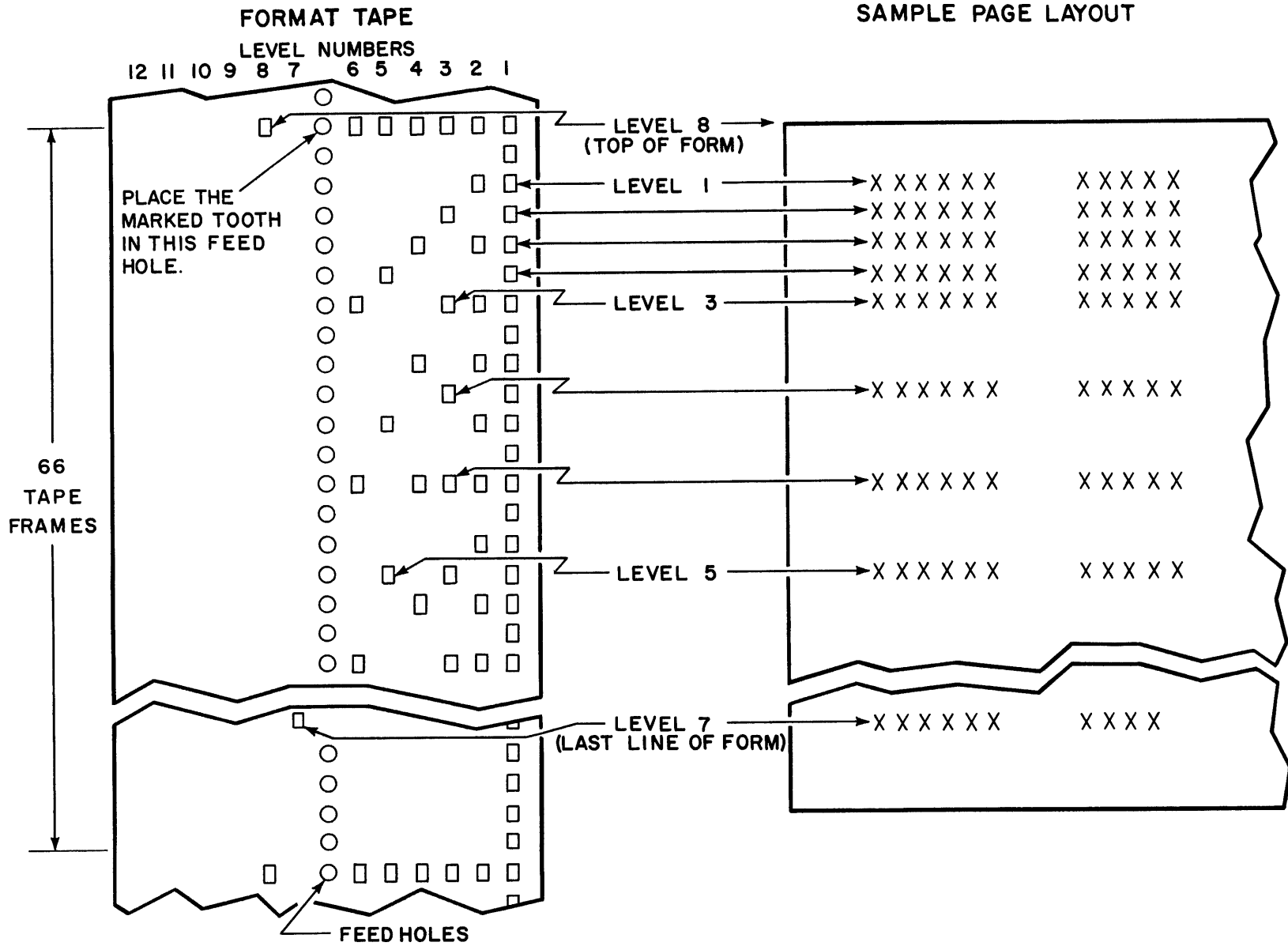

Figure E-2. Format Tape (6 Lines per Inch)

Levels are selected by sending the appropriate function codes. Selecting any of the Levels 1 through 6 provides a means of extending the automatic single-space feature to include more than one line. For example, if code 0014 is selected, paper starts moving after the next line has been printed and continues to move until the brush reader senses a hole in Level 4 of the tape. By using the preprint function codes, paper may be moved before printing. Holes may be punched in Levels 1 through 6 in any desired pattern.

Level 8 must always contain only one hole punched in the top of form position. This level may be selected by function code 0004 or by pressing the PAGE EJECT switch on the control panel.

Level 7 also contains only one hole which corresponds to the last line of print on the form. This hole may be punched in any frame according to the required format. In Figure E-2, the hole in Level 7 is in frame 62; consequently, the last line is printed on line 62 of the paper.

In the example shown in Figure E-2, hole levels and paper spaces correspond as follows:

- Level 1 = 1 space
- Level 2 = 2 spaces
- Level 3 = 3 spaces
- Level 4 = 4 spaces
- Level 5 = 5 spaces
- Level 6 = 6 spaces
- Level 7 = Last line of form
- Level 8 = Top of form

Selection of level numbers 1 through 6 by function code determines paper spacing. Levels can be selected in any order. For example, if Level 1 is selected, the arrangement of holes in the format tape results in the paper being single spaced (Figure E-2).

If lines 5 through 13 are to be triple spaced, and postprint spacing is selected, the hole selection for Level 1 must be cleared and Level 3 format tape holes must be selected for lines 5 through 13 by function code. If 5 spaces are required between a group of lines, Level 3 must be cleared and the Level 5 tape hole selected. Lines are spaced in this manner (5 spaced) to the end of the form (Level 8) unless new spacing instructions are received.

If preprint spacing is selected, spacing operations are the same as for postprint spacing except that the previous level selection need not be cleared before selecting a new level.

The format tape reader can be used with either 6- or 8-line-per-inch paper spacing. However, care should be taken when switching from one type of spacing to another. For example, if 8-line-per-inch spacing is selected on the 6 LINE/8 LINE switch, and the tape is punched for 6 lines per inch, irregular spacing will result.

Both 6-line and 8-line format tapes must be installed in the below manner. The sprocket wheel on which the tape is mounted contains alternately marked teeth. Mount the tape on the sprocket wheel so that a marked tooth protrudes through a tape feed hole which is in line with a Level 8 square-punched hole (Figure E-2).

SECTION A

3691-A/B PAPER TAPE READER/PUNCH

CONTENTS

Functional Description	A-1	Parity Checking (Transmission) Codes	A-5
Assembly/Disassembly	A-1	Connect Codes	A-8
Paper Tape Formats	A-2	Function Codes	A-8
Modes	A-2	Status Codes	A-11
Connect	A-2	Switches and Indicators	A-12
Function	A-3	Operation and Programming	A-14
Interrupts	A-4	Timing Considerations	A-14
Status	A-5		

FIGURES

A-1	Typical Configuration	A-1	A-2	Switch and Indicator Panel	A-12
-----	-----------------------	-----	-----	----------------------------	------

TABLES

A-1	Connect, Function, and Status Codes	A-7
-----	-------------------------------------	-----

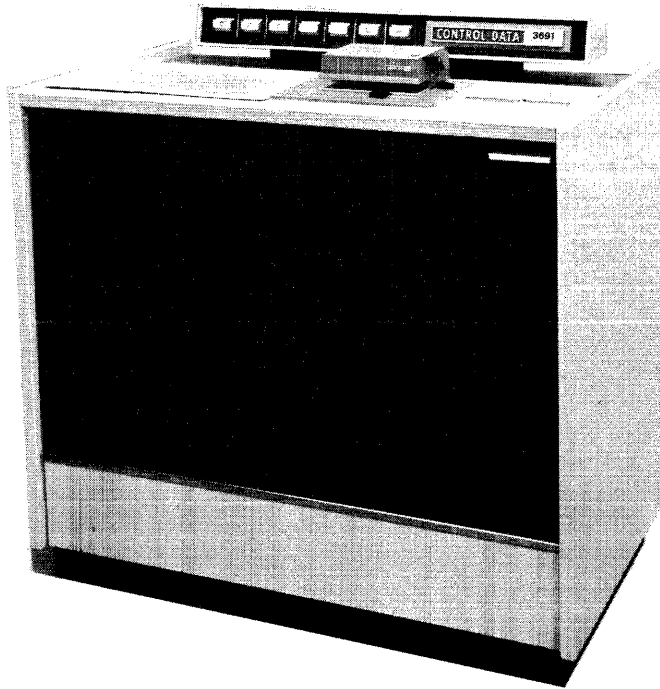

3691-A PAPER TAPE READER/PUNCH

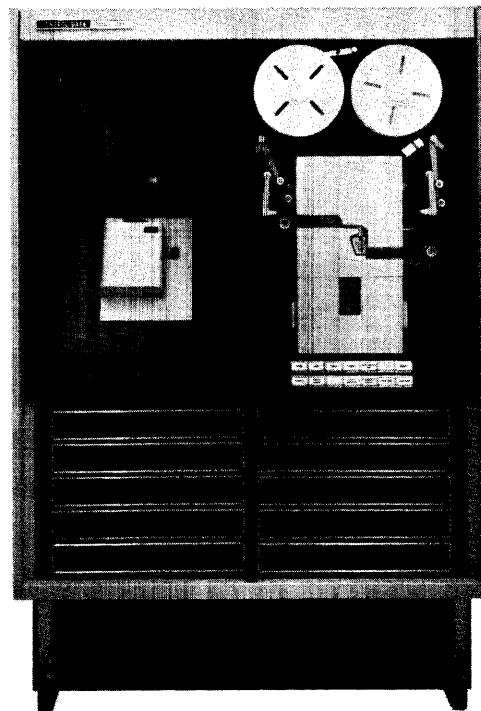

3691-B PAPER TAPE READER/PUNCH

3691-A/B PAPER TAPE READER/PUNCH

The CONTROL DATA* 3691 Paper Tape Reader/Punch Controller facilitates the transfer of data between a CONTROL DATA 350 Paper Tape Reader or a Teletype BRPE-11** Paper Tape Punch and any 3000 Series data channel. (See Figure A-1.)

This section describes the disassembly of data received from the data channel and the assembly of data received from the reader. It also describes the Connect, Function, and Status codes and provides pertinent programming information.

FUNCTIONAL DESCRIPTION

The 3691 Controller has one read/write control. This control may be physically attached to one 3000 Series data channel. Since the control is shared by both the reader and the punch, it is not possible for the channel to communicate with both devices simultaneously.

ASSEMBLY/DISASSEMBLY

During Write operations, the control receives data from the data channel in 12-bit bytes (i. e., 12 bits of data are received simultaneously on 12 data lines). The punch, however, can handle only 5 to 8 bits of data at a time.*** The control, therefore, must either transfer only the lower 5 to 8 bits of a byte to the punch or it must disassemble the byte into two 6-bit characters for transfer to the punch.

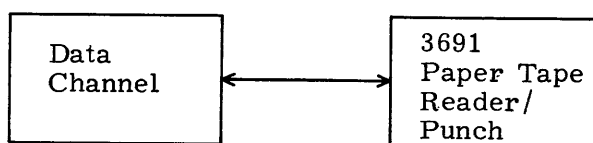

Figure A-1. Typical Configuration

*Registered trademark of Control Data Corporation

**An NCR EM-32 Punch is installed on the 3691-B Controller.

***This depends on the tape level.

Disassembly is automatically suppressed when a 3100/3200 Character Output instruction (OUTC or OTAC) is executed.

During Read operations, the reader may transfer 5 to 8 bits of data to the control. The control must either transmit this data as received to the data channel or it must assemble two 6-bit characters into a 12-bit byte and then transmit the byte to the data channel.

Assembly is automatically suppressed when a 3100/3200 Character Input instruction (INPC or INAC) is executed.

PAPER TAPE FORMATS

The punch perforates tape of five, seven, or eight levels* at speeds of up to 110 characters per second.

Five, seven, or eight level tape of standard widths can be read photoelectrically at speeds up to 350 characters per second. A switch on the unit must be set to indicate the number of tape levels being read.

MODES

Seven or eight level tape may be processed in Assembly/Disassembly mode (two 6-bit characters are processed per byte) or Character mode (the lower 5, 7, or 8 bits of the byte are used).

Five level tape must be processed in Character mode.

CONNECT

The controller must be connected to the data channel before it can respond to either a Select/Function instruction or Read or Write instructions. Connection is accomplished by the Connect instruction; the Connect code (N00U)** is the lower 12 bits of this instruction. The controller connects and returns a Reply*** to the data channel if:

*Two screws must be manually removed and replaced on the BRPE-11 guide when it is converted from five to seven or eight or from seven or eight to five level tape.

**U = 0 for reader; U = 1 for punch

***A Reply signal tells the central processor to process the next instruction.

- 1) The N portion of the Connect code matches the setting of the Equipment Number switch.
- 2) A transmission parity error is not detected.

If the N portion of the Connect code does not match the setting of the Equipment Number switch, neither a Reject nor a Reply is returned to the channel from this equipment. Equipment status is not made available to the channel. If the controller was connected prior to receiving this code, it automatically disconnects. If neither a Reply nor a Reject is returned to the data channel from any of its attached equipments within 100 microseconds, the central processor generates an Internal Reject.

If a parity error is detected in a Connect code, the device does not connect* and neither a Reject nor a Reply is returned to the data channel. Instead, the Parity Error indicator lights. These parity error conditions must be cleared by either a Clear Channel instruction or a Master Clear prior to a new connect attempt.

FUNCTION

Function codes are used to prepare a connected control and/or unit for an Input/Output operation. (They have no effect on unconnected controls or units.) They comprise the lower 12 bits of a Select/Function** instruction and are transmitted to the control on the 12 data lines. Table A-1 lists these codes. A detailed description of each code follows the table.

The control examines only one code at a time. First, it checks for parity errors. If none are found, it returns a Reply if the requested function can be performed*** or a Reject if it cannot be performed.

If a parity error is detected, the function is not performed, a Parity Error signal is returned to the data channel, and the Parity Error indicator lights. Since neither a Reply nor a Reject is returned to the data channel, the central processor generates an Internal Reject after a wait of 100 microseconds.

These parity error indications must be cleared by either a Clear Channel instruction or a Master Clear. The equipment must then be reconnected before a new function code is examined by the controller.

*If the device is connected, it automatically disconnects.

**Select in 3100/3200 systems; Function in 3400/3600/3800 systems

***All illegal function codes cause a Reply to be returned. However, in these cases no action follows.

INTERRUPTS

Interrupts provide a means for attaining optimum utilization of a system's computational and input/output capabilities. The interrupt system includes the pertinent instructions and codes as well as the necessary logic. Basically, the system interrupts (halts) the main program and initiates an interrupt processing program* when an Interrupt signal is sent to the processor.

The 3691 Controller can be programmed to send an Interrupt signal to the processor when any one of the conditions specified by the three interrupts** materializes.

A Select Interrupt code permits the controller to consider as a group*** several of the operating conditions which may occur in an attached unit. If a specific interrupt has been selected and if at least one of the conditions specified by it occurs in the connected unit, the controller sends an Interrupt signal to the processor. If the interrupt system in the processor has been set to recognize the interrupt, the main program is interrupted and control is transferred to a specific program address. Status sensing and followup operations may follow. If desired, control may be returned to the main program by an appropriate Jump instruction located at the close of the interrupt processing program.

If the processor's interrupt system has not been enabled, it is still possible to sense for these conditions via Sense Status and Copy Status instructions written into the main program.

Regardless of which of the above actions is followed, the Interrupt signal remains up until cleared by reselecting the interrupt, selecting release, or master clearing the system. The Interrupt signal is transmitted on the equipment's interrupt line via the data channel currently connected to or reserving the equipment.

The eight-position (0-7) Equipment Number switch determines the number of the line on which the Interrupt signal is transmitted. For example, if the Equipment Number switch is set at 5, all Interrupt signals coming from this control are transmitted on interrupt line 5. Since each equipment attached to a data channel has a unique equipment number,

*See the system reference manual for the addresses pertinent to the interrupt processing.

**See explanation of function codes following Table A-1 for a list of these conditions.

***See description of function codes following Table A-1 for a breakdown of the three possible groups.

each uses a different interrupt line. A Channel Product Register Jump instruction* or a Copy Status instruction** can identify the equipment sending the Interrupt signal by inspecting the interrupt lines.

STATUS

Status codes permit the monitoring of several control/unit operating conditions. These codes are made available to the data channel over 12 status lines following a connect or a rejected connect attempt. Sense Status and Copy Status instructions make these codes available to the central processor.

See Table A-1 for a complete list of these codes. If two or more conditions exist simultaneously, the Status Response code is the sum of the individual codes. A detailed description of each code follows the table.

PARITY CHECKING (TRANSMISSION)

Connect codes, function codes, and data are transmitted between the data channel and the controller in odd parity (i. e., the number of "1" bits transmitted must be odd). If the number of "1" bits in a data byte is even, a "1" is transmitted on the parity line to make the total number of "1" bits odd.*** If the number of "1" bits in the data byte is odd, a "1" is not transmitted on the parity line.

A transmission parity error exists if the total number of "1" bits transmitted on the 12 data lines plus the parity line is even, indicating that a bit has been lost or picked up.

Parity Error in a Connect Code

If a parity error is detected in a Connect code, the device does not connect**** and neither a Reject nor a Reply is returned to the data channel. Instead, the Parity Error indicator lights. These parity error conditions must be cleared by either a Channel Clear or a Master Clear prior to a new connect attempt.

*3600/3800 systems

**3100/3200/3400 systems

***Do not confuse this line with the parity error line.

****If the device is connected, it automatically disconnects.

Parity Error in a Function Code

If a parity error is detected, the requested functions are not performed, a Parity Error signal is returned to the data channel, and the Parity Error indicator lights. Since neither a Reject nor a Reply is returned to the data channel, the central processor generates an Internal Reject after a wait of 100 microseconds. These parity error indications must be cleared by a Clear Channel instruction or a Master Clear.* The equipment must then be reconnected before a new function code can be examined by the controller.

Parity Error in Output Data

If a transmission parity error is detected by the controller during a Write operation, the Parity Error indicator lights and sends both a Reply and a Parity Error signal to the data channel. The data is written on tape. All operations continue** unless appropriate programming steps have been taken to sense the Parity Error signal and rewrite the data. These parity error indications must be cleared by either a Clear Channel instruction or a Master Clear. The equipment must then be reconnected and the appropriate functions reselected prior to the new output.

Parity Errors in Input Data

Transmission parity errors may be detected by the data channel on data received from the equipment. If a parity error is detected, a parity error bit in the data channel is set and a Parity Error indicator on either the channel or console is lighted. The faulty data is entered into either core storage or the A register. All operations continue*** unless appropriate programming steps have been taken to sense for the set bit and reread the data. These parity error indications may be cleared by a Clear Channel instruction or a Master Clear issued by any 3000 Series system and by a new Read or Write from a 3100/3200 system. Following a Clear Channel instruction or a Master Clear, the equipment must be reconnected and the appropriate functions reselected prior to a new input.

*Though operations may continue normally, the validity of a new function code and/or data prior to a Master Clear or Clear Channel is questionable.

**The validity of the data received from this point until a Clear Channel or Master Clear is questionable.

***The validity of the data received from this point until the indicators are cleared is questionable.

Input/Output Parity Error Bit in the Data Channel

The input/output parity error bit is set whenever a transmission parity error is detected. If the error is detected by the external equipment, the bit is set by the Parity Error signal.

In 3400/3600/3800 systems, an Interrupt signal is generated when this bit sets. If the interrupt system has not been set to detect the setting of this bit, the bit may be sensed to detect parity error conditions.

In 3100/3200 systems, the bit must be sensed if transmission parity error conditions are to be detected by the central processor.

Refer to the appropriate system reference manual for more information on the input/output parity error bit.

CODES

All connections and operations are controlled by 12-bit Connect and function codes in conjunction with the appropriate Connect or Select/Function instruction. In all discussion of codes, bit 0 is in the rightmost position. (See Table A-1.)

TABLE A-1. CONNECT, FUNCTION,
AND STATUS CODES

CONNECT	
Connect Reader	N000*
Connect Punch	N001
FUNCTION	
Release and Disconnect	0000
Assembly Mode	0001
Character Mode	0002
Clear	0005
Select Interrupt on Ready and Not Busy	0020
Release Interrupt on Ready and Not Busy	0021
Select Interrupt on End of Operation	0022

*N = equipment number of controller

TABLE A-1. CONNECT, FUNCTION,
AND STATUS CODES (Cont'd)

FUNCTION (Cont'd)	
Release Interrupt on End of Operation	0023
Select Interrupt on Abnormal End of Operation	0024
Release Interrupt on Abnormal End of Operation	0025
STATUS	
Station Ready	XXX1
Station Busy	XXX2
Punch Tape Supply Low	XXX4
Reader Last Device	XX1X
Paper Motion Failure	XX2X
Interrupt on Ready and Not Busy	X2XX
Interrupt on End of Operation	X4XX
Interrupt on Abnormal End of Operation	1XXX

CONNECT CODES

*Connect Reader (N000)**

This code connects the reader.

Connect Punch (N001)

This code connects the punch.

FUNCTION CODES

Release and Disconnect (0000)

This code clears the existing unit connection.

*N must match the setting of the Equipment Number switch on the controller.

*Assembly/ Disassembly Mode (0001)**

This code allows the following to occur:

Reader (Assembly Mode)**

The first frame of tape containing a level seven hole** is processed first. Data stored in levels one through six is placed in the upper 6 bit locations of the first byte. Data stored in levels one through six of the next frame is placed in the lower 6 bit locations of that byte. This sequence continues with odd frame data being placed in the upper 6 bits of a byte and the next (even) frame data completing the byte. When the last byte of a computer word has been transferred, the next frame begins a new word and should contain a level seven hole. If the control hole does not appear, tape motion stops and an End of Record signal is sent to the data channel.

Punch (Disassembly Mode)***

The first frame is punched with a level seven hole and the information contained in the upper 6 bits of the first 12-bit byte. The lower 6 bits of the byte go to the second frame and so on. Thereafter, the level seven hole is punched along with the upper 6 bits of the first byte of a computer word only.

Character Mode (0002)

This code allows the following to occur:

Reader****

Information goes directly from the tape to the lower order bits (0-5, 6 or 7) of the byte. The information is stored in destination bit locations 0-5, 6 or 7.

*Not applicable to five level tape.

**If used in conjunction with 3100/3200 Input Character instructions, data stored in levels one through six of each frame is transmitted to the data channel. An odd number of frames may be read in this manner.

***If used in conjunction with a 3100/3200 Output Character instruction and seven or eight level tape is used, each frame contains a level seven hole along with the desired data. An odd number of frames may be punched in this manner.

****If seven or eight level tape is used in conjunction with 3100/3200 Input Character instructions, information stored in levels seven and/or eight is lost. An odd number of frames may be read.

Punch*

The lower order bits (0-5, 6 or 7) of the computer word are transferred to the paper tape.

Clear (0005)

This code clears all selected interrupts and Interrupt signals and puts the controller in Assembly/Disassembly mode.

Select Interrupt on Ready and Not Busy (0020)

This code causes the controller to send an Interrupt signal to the processor when the reader or the punch becomes Ready and Not Busy (i. e., power is applied, the Ready switch is lighted, and neither a reader nor a punch cycle is in progress). The control accepts and replies to this code on receipt.

Once up, the Interrupt signal remains up until cleared by reselecting the interrupt (0020), selecting release (0021), Clear (0005), Clear Channel, or Master Clear.

Release Interrupt on Ready and Not Busy (0021)

This code clears an Interrupt on Ready and Not Busy selection and the Ready and Not Busy Interrupt signal if it is up. The control accepts and replies to this code on receipt.

Select Interrupt on End of Operation (0020)

This code causes the controller to send an Interrupt signal to the processor when the Input/Output operation is complete or when the controller becomes Not Ready. The control accepts and replies to this code on receipt. Once up, the Interrupt signal remains up until cleared by reselecting the interrupt (0022), selecting release (0023), Clear (0005), Clear Channel, or Master Clear.

*If five level tape is used in conjunction with 3100/3200 Output Character instructions, bit 5 of the output character is lost. If seven or eight level tape is used, information may be punched in levels one through six only. No level seven or level eight punches are made. An odd number of frames may be punched.

Release Interrupt on End of Operation (0023)

This code clears an Interrupt on End of Operation selection and the End of Operation Interrupt signal if it is up. The control accepts and replies to this signal on receipt.

Select Interrupt on Abnormal End of Operation (0024)

This code causes the control to send an Interrupt signal to the processor when an abnormal end of operation occurs. The control accepts and replies to this code on receipt. Once up, the Interrupt signal remains up until cleared by reselecting the interrupt (0034), selecting release (0035), Clear Channel, or Master Clear.

Release Interrupt on Abnormal End of Operation (0025)

This code clears an Interrupt on Abnormal End of Operation selection and the Abnormal End of Operation Interrupt signal if it is up. The control accepts and replies to this code on receipt.

STATUS CODES

Station Ready (XXX1)

Bit 0 is set when the connected device is Ready.

Station Busy (XXX2)

Bit 1 is set when either a Punch or a Read operation is in progress.

Punch Tape Supply Low (XXX4)

Bit 2 is set when the punch is connected and the remaining tape supply is considered less than the amount required for an average-length output.

Reader Last Device (XX1X)

Bit 3 is set when the reader was the previously connected device.

Paper Motion Failure (XX2X)

Bit 4 is set when there is no paper motion in response to an input/output request.

Interrupt on Ready and Not Busy (X2XX)

Bit 7 is set when Interrupt on Ready and Not Busy is selected and this condition now exists.

Interrupt on End of Operation (X4XX)

Bit 8 is set when Interrupt on End of Operation is selected and at least one condition specified by it now exists.

Interrupt on Abnormal End of Operation (1XXX)

Bit 9 is set when Interrupt on Abnormal End of Operation is selected and at least one condition specified by it now exists.

SWITCHES AND INDICATORS

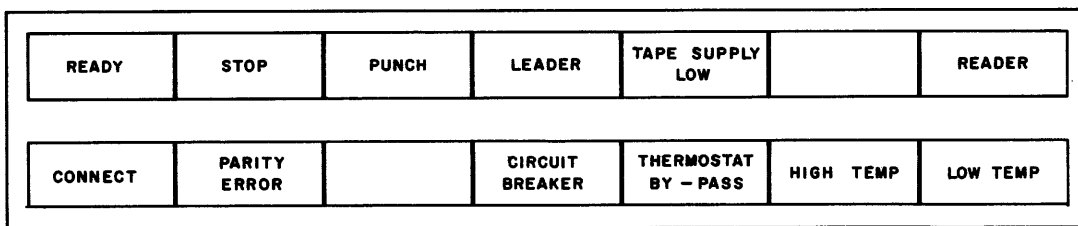

Figure A-2. Switch and Indicator Panel

EQUIPMENT NUMBER SWITCH*

The Equipment Number switch is an eight-position switch. Its setting (0-7) designates the controller and corresponds to the N portion of the Connect code. It also determines the number of the interrupt transmission line that the equipment uses.

*This switch is located on the logic panel.

PUNCH SWITCH

This switch turns punch motor on and off.

LEADER SWITCH

This momentary-contact switch causes the punch to feed tape until the switch is released.

READER SWITCH

This switch turns the exciter and reader motor on and off.

READY SWITCH

This momentary-contact switch makes the station Ready after loading or reloading. It is lighted when the unit is Ready.

PARITY ERROR INDICATOR

If this indicator is lighted, a parity error is detected by the controller. A Master Clear or Clear Channel instruction causes the indicator to go out.

CONNECT INDICATOR

This indicator lights when the station is connected.

STOP SWITCH

This momentary-contact switch causes the station to become Not Ready. Reader/punch motion stops.

TAPE SUPPLY LOW INDICATOR

This indicator lights when the punch tape supply is low.

CIRCUIT BREAKER SWITCH

When lighted, this switch indicates a power supply overload. Pressing the switch resets the circuit breakers. This switch also acts as a power switch, applying power to the logic chassis, blowers, and PUNCH and READER switches.

OPERATION AND PROGRAMMING

TIMING CONSIDERATIONS

Reader

A new Read must be initiated within 0.8 millisecond if tape stoppage is to be avoided.

Punch

A new Write must be initiated within 3 seconds if punch stoppage is to be avoided.

SECTION A

3436/3637 DRUM STORAGE CONTROLLERS

CONTENTS

Functional Description	A-1	Buffer Timing	A-27
Subsystem Configuration	A-2	Addressing	A-28
Drum Units	A-3	863 Format	A-30
Drum Controllers	A-7	865 Format	A-31
Storage	A-8	Programming Considerations	A-32
Data Format	A-8	Program Compatability	A-32
Address Characteristics	A-10	865 I/O Operations	A-33
Data Transfer	A-10	Simultaneous Selection	A-33
Performance Timing	A-12	Buffer Restrictions	A-33
Codes	A-13	Master Clear, Release and	
Connect Code	A-14	Disconnect	A-33
Function Codes	A-15	Not Ready	A-34
Status Codes	A-21	Interrupts	A-34
Subsystem Errors and		Write Timing	A-34
Performance	A-24	Manual Operations	A-36
Lost Data Error	A-24	Sample Program Routine	A-40
Parity Errors	A-24	Program Sequence	A-40
Not Ready Causes	A-26	Program	A-41

FIGURES

A-1 Typical Drum Subsystem	A-2	A-8 Holding Register During	A-29
A-2 Theoretical Byte Recording Format	A-9	A-9 863 Drum Address Format	A-30
A-3 Connect Code Format	A-14	A-10 865 Drum Address Format	A-31
A-4 Function Code Format	A-15	A-11 Drum Unit Switches and	
A-5 Write Timing	A-28	Indicators	A-37
A-6 Holding Registers During		A-12 Controller Interior Switches	
Write Operations	A-28	and Indicators	A-38
A-7 Read/Write Check Timing	A-29		

TABLES

A-1 Drum Capacity and Transfer Specifications	A-11	A-3 Connect, Function, and Status Codes	A-13
A-2 Interlace Specifications	A-11	A-4 Switches and Indicators	A-38

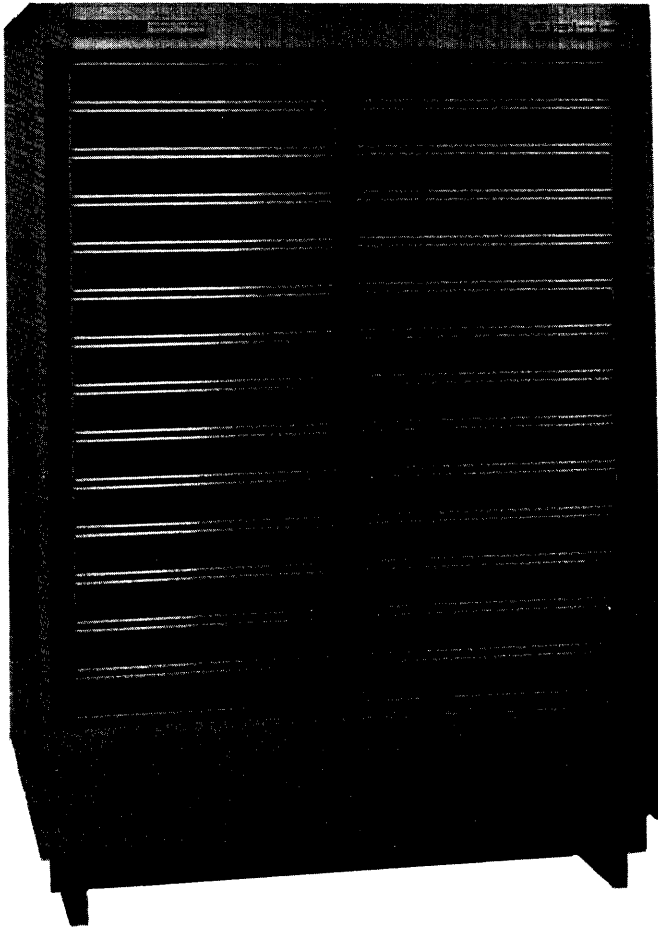

DRUM STORAGE CONTROLLER

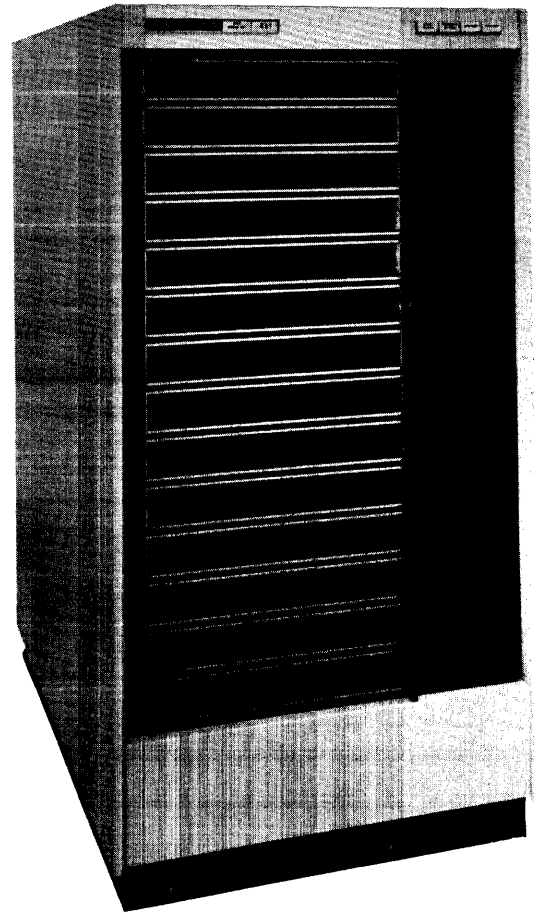

DRUM STORAGE UNIT

1176 1407

3436/3637 DRUM STORAGE CONTROLLERS

This section describes a drum storage subsystem consisting of the CONTROL DATA® 3436/3637 Drum Storage Controllers, CONTROL DATA® 3000 Series Data Channels, and the following peripheral storage devices: CONTROL DATA® 861/863 and 865 Drum Storage Units. It includes relevant system specifications, programming procedures, codes, manual operating information and sample program routines. It is assumed the reader is familiar with 3000 Series logic, instructions, and procedures.

The following terms are used throughout this section and are defined here for clarification:

- **Drum:** The physical drum assembly, consisting of the drum drive motor, recording surface, drum case and logic mounted thereon. It does not include the cabinet which houses the drum assembly.
- **Drum Unit:** The drum and cabinet in which it is housed along with the associated drum unit logic and electronics.
- **Drum Controller:** The logic interface between the drum unit(s) and the data channel(s) and the cabinet in which the logic is housed.

FUNCTIONAL DESCRIPTION

The controllers, in conjunction with the drum units operate as a drum storage subsystem having medium access time, nonvolatile, mass-memory facilities. The subsystem provides large-volume data storage with high-speed transfer capabilities.

The subsystem incorporates features which permit:

- 1) Byte addressable data access in the 863 Drum Units.
- 2) Sector addressable data access in the 865 Drum Units.
- 3) Continuous addressing throughout each drum unit.
- 4) Data checking on completion of a Write operation (Write Check).
- 5) The ability to determine the approximate drum angular position for maximum programming efficiency.

SUBSYSTEM CONFIGURATION

Two major elements constitute the drum storage subsystem: The drum controllers and the drum units. Up to eight drum units may be connected to each controller, and each drum unit may be connected to two controllers. Thus, the controller/drum unit configuration allows two or more computing systems to be integrated via the drum units and permits multiple operations to take place within a system. Figure A-1 shows a typical drum subsystem. Solid lines encompass the equipments necessary for a minimum subsystem; dashed lines indicate subsystem expansion capabilities.

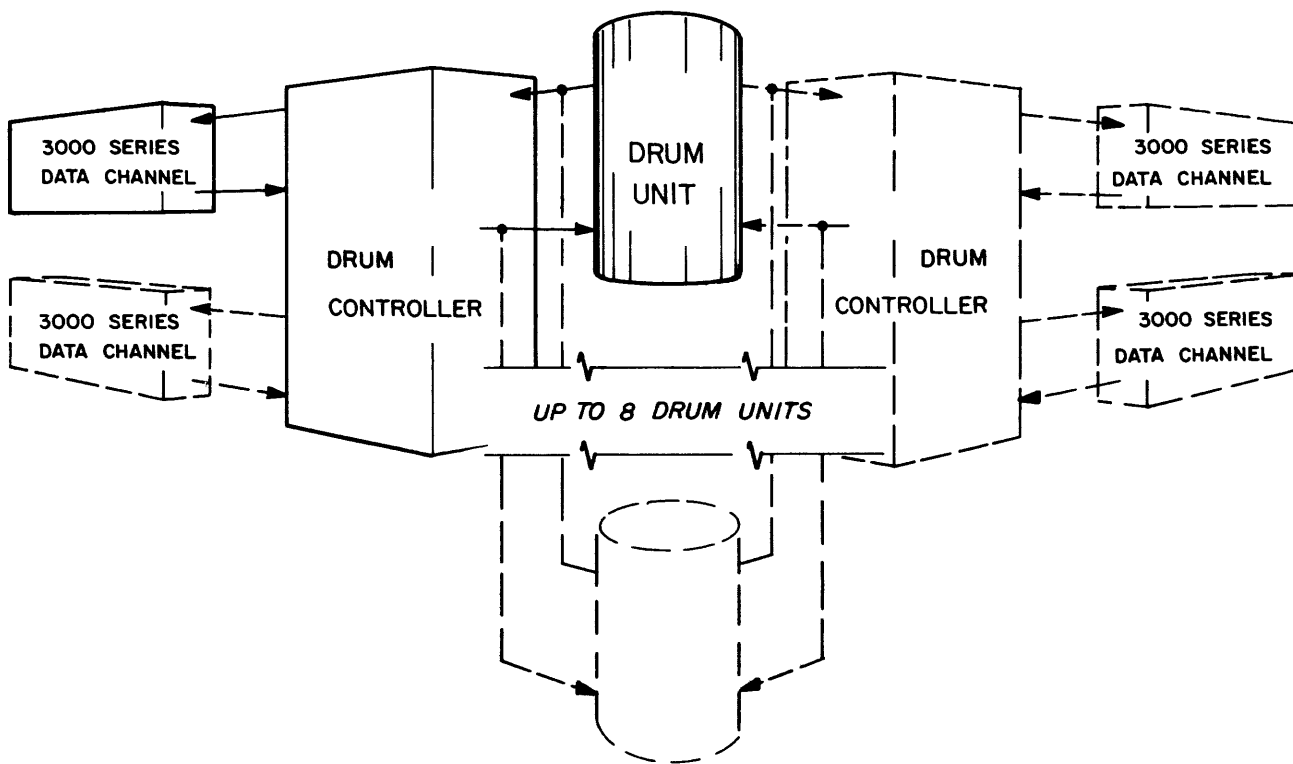

Figure A-1. Typical Drum Subsystem

The subsystem incorporates features that allow the controller to operate with two 3000 Series Data Channels on a time-shared basis. The data channels provide an interface between the computers and the controllers. The subsystem also allows time-shared drum operations between controllers in the system. In this case, the drum unit acts as a common storage medium between the two controllers.

A description of equipment which may be incorporated into the drum storage subsystem, and its capabilities, is shown below.

3436-A Drum Storage Controller - Provides a single data channel interface to any of the 861/863 Drum Units.

3637-A Drum Storage Controller - Provides a dual data channel interface to any of the 861/863 Drum Units.

3637-B Drum Storage Controller - Provides dual data channel interface to any of the 861/863/865 Drum Units.

861-B Drum Unit - Provides byte addressable data storage (2,097,152 data bytes) with variable transfer rate capabilities.

863-B/C Drum Unit - Provides byte addressable data storage (2,097,152 data bytes) with variable transfer rate capabilities.

865-A/B Drum Unit - Provides sector addressable data storage (128 data bytes/sector; 4,194,304 bytes total capacity) at a fixed transfer rate.

Most of the information in this section is common to all of the equipment. Information that is unique to a particular controller or drum unit is so stated. The 861-B and 863-B Drum Units are similar. For simplicity, only the 863 is referenced throughout this section; however, all references and information applicable to the 863 also apply to the 861.

DRUM UNITS

The basic purpose of the drum unit (which houses the drum and associated electronics) is to provide recording surfaces for storage of data. The drum, which is mounted on a vertical axis, is plated with a metallic recording medium. Each 863 drum contains 832 recording tracks; each 865 drum contains 768 recording tracks. Six other tracks are used to make up three sets of control timing tracks. One track of each set provides timing (Clock pulses); the other track of each set provides reference (indexing) information.

One of the three sets of control tracks is designated as a master set; the other two sets are designated as working sets. Provision is made within each drum unit for rewriting the working tracks from the master set while the master set may be written or rewritten via an external oscillator (one megacycle for the 863 Drum Unit; two megacycles for the 865 Drum Unit).

The drum unit also contains the drum drive motor, the R/W heads, and the associated drum electronics. Provision is made within the 861/863 drum units for manual selection of the interface transfer rates and drum size. All drum units provide for setting of the unit designation (unit number), and various maintenance switch functions.

The exchange of the following signals between the controller and drum units is necessary to control drum operation: (C → D) indicates the signal originates in the controller and is sent to the drum; (D → C) indicates the signal originates in the drum and is sent to the controller.

Select (C → D)

This signal is sent to all drum units attached to the controller. The signal indicates that the unit code is on the line and causes the drum unit to examine the code.

Select Reply (D → C)

This signal is sent in response to the Select signal and indicates that the designated drum unit has been selected. Absence of the signal indicates that the desired drum was unavailable (either no such drum exists or the drum is reserved by another controller).

Head Group Address (C → D)

These signals carry the 8-bit head group code (and Head Sub-group in the 865) from the controller Address register. The signals are decoded by the drum unit to select the appropriate head group (and head sub-group in the 865).

Angular Address (C → D)

These signals carry the 15-bit (14-bit in the 865) angular address to the drum unit from the controller Address register. For the 863, the signals are decoded according to the interlace to determine the angular position of the data to be read or written. For the 865, the signals are decoded to determine the starting sector address of the data to be read or written.

Read Angular Count (D → C)

These 12 signals carry: 1) from the 863, the upper 12 bits of the 15-bit Angular Count. This indicates within 8 byte locations the present position of the drum; 2) from the 865, (in the lower order positions) the 7-bit sector address portion of the Angular Count. This indicates the sector presently being referenced by the drum.

Write (C → D)

This signal indicates the data is on the lines and directs the drum unit to record the data at the addressed location or sector.

Read (C → D)

This signal directs the drum unit to read data from the addressed byte or sector.

Data Ready (D → C)

This signal (sent in response to the Read signal) indicates that the requested byte (in the case of the 863) is on the lines to the controller. For the 865, the signal indicates that a data byte (from the requested sector) is on the lines to the controller.

Compare (D → C)

This signal indicates that the drum unit is presently accessing the byte (for the 863) or the sector (for the 865) location indicated by the controller Address register. In the case of the 863, the signal initiates the Read operation within the controller if in the Read mode. In the case of the 865, this signal comes up only at the beginning of the addressed sector. For both the 863 and 865, the signal activates the Address Compare interrupt if selected.

Write Reply (D → C)

This signal is sent in response to a Write signal. It indicates that the Write operation has been accepted by the drum unit and will commence upon determination of a successful Write Compare.

Write Compare (D → C)

This signal is sent in response to a Write signal. It indicates that the angular address sent by the controller and the angular position of the drum compare and that the previously selected Write operation is being initiated at that location.

Index (D → C)

This is the Stop Index signal from the index control track. The signal indicates the end of the clock and the beginning of the dead zone and head switching time for each revolution of the drum.

Drum Ready (D → C)

This signal indicates that the unit code and the designation switch setting agree, the drum is up to speed, and no timing errors exist.

Clock (D → C)

Two clock signals (Clock 1 and Clock 2) are sent by the selected drum unit. The signals come from the control timing tracks and provide the two phases of the 1-MHz clock. (The 865 drum 2-MHz clock is broken down to 1 MHz for controller use.)

Release (C → D)

This signal removes all operating modes and reserves in the drum units; however, it does not affect any drum unit reserved by another controller.

MC (C → D)

This signal clears most logic conditions, selections, and reserves within the drum units; however, it does not affect any drum unit reserved by another controller.

Manually initiated Master Clear removes all error conditions and the Drum Ready condition, causing the drum to recheck all timing and synchronization before becoming Ready again. (This requires approximately 70 ms.)

Drum Type (D → C)

When a logical 1, this signal indicates that the selected drum unit contains an 863 Drum with 32K byte storage per head group; when a logical 0, this signal indicates that the selected drum unit contains an 865 Drum with 65K byte storage per head group.

Data Error (D → C)*

The presence of this signal indicates that either a Transmission Parity Error has been detected during a Write operation, or that a Checkword Error has been detected during a Read operation.

*These signals are only applicable to and returned only by the 865 Drum Units.

Busy (D → C)*

The presence of this signal indicates that the drum unit is busy with a data handling operation. Note that even if a Write or Read operation terminates prior to the end of the sector, the drum unit remains busy until the checkword is read or written at the end of that sector.

Lost Data (D → C)*

The presence of this signal indicates that 1) the data channel has failed to maintain the proper transfer rate while writing, (the controller checks for Lost Data during Read operations), or 2) the byte address portion does not contain all zeros when a new I/O initiation is attempted. (All I/O operations must commence at the beginning of a sector. At that point the byte address portion equals all zeros).

In addition to the signals, 13 bidirectional lines carry the data and parity information and Connect codes between the controller Transfer register and the drum unit.

DRUM CONTROLLERS

The standard 3000 Series signals are exchanged between the controller and the data channel. The controller provides an interface between the drum units and the computer via the data channels. The controller translates the Connect and function codes issued by the computer to control drum operation. The controller synchronizes and transfers data between the drums and the computers in a parallel 13-bit byte format.

The computers control the drum (and controller) operations through the use of 12-bit function codes and a 21-or 22-bit address word** (dependent upon the type of drum unit in use). Issuing of a function code specifying a mode of operation prepares the controller and drum unit for an I/O operation. The drum seeks the specified head group and the sector or angular address position specified by the contents of the Address register in the controller. The specific operation commences upon initiation of an I/O at the location specified by the address.

*These signals are applicable to the 865 Drum Units.

**For specific format and address word information, refer to ADDRESSING.

Subsequent to the initiation of an I/O to/from the drum, the computer may issue a Load Address code followed by 2 bytes which form the address word. If an address word is issued, it is loaded into the controller Address register, and the next operation commences at this new address location. If no new address is received by the controller prior to the initiation of an I/O, operation commences at the address presently held in the Address register*.

STORAGE

The types of drum units are similar in that they are all mounted in identical cabinets, they all utilize a metallic magnetic recording medium, and all have the same number of data recording tracks per unit. The drums differ in their physical appearance, bit and track arrangement, and logically in their recording and addressing techniques and total storage capacities.

863 Drum Units

These drums have 768 data tracks and 64 parity tracks. The tracks are divided into 64 groups of 13 tracks each (12 data and one parity track per group). The groups are organized vertically on the drum and are referred to as head groups. Each bit of a byte is written on a separate track of the group (see Figure A-2). Each track provides 32,768 bits of storage with a total capacity of 25,165,824 data bits (4,194,304 6-bit characters) per drum unit.

865 Drum Units

These drums have 768 data tracks divided into 64 head groups of 12 tracks each. Each head group is further sub-divided into four subgroups of 3 tracks each. Four bits of each byte are written serially on each of the three tracks of the subgroup. The bytes are written serially and in parallel as three groups of 4 bits each. (See Figure A-2.)

DATA FORMAT

Each 12-bit byte plus an associated parity bit is transferred in parallel between the data channels and the controller, and between the controller and selected drum units.

*With the 865 Drum, the byte portion of the address must equal zero or a Lost Data Error will occur upon initiation of the operation.

863 Drum Units

In the 863 Drum Units the bytes are recorded in parallel on the 13 tracks of a head group. Data is written on the drum in a byte format within a head group: bytes are recorded by laying down 1 bit in each of the 13 tracks of the head group. Any byte may be read or written without interference or reference to adjacent bytes (bits).

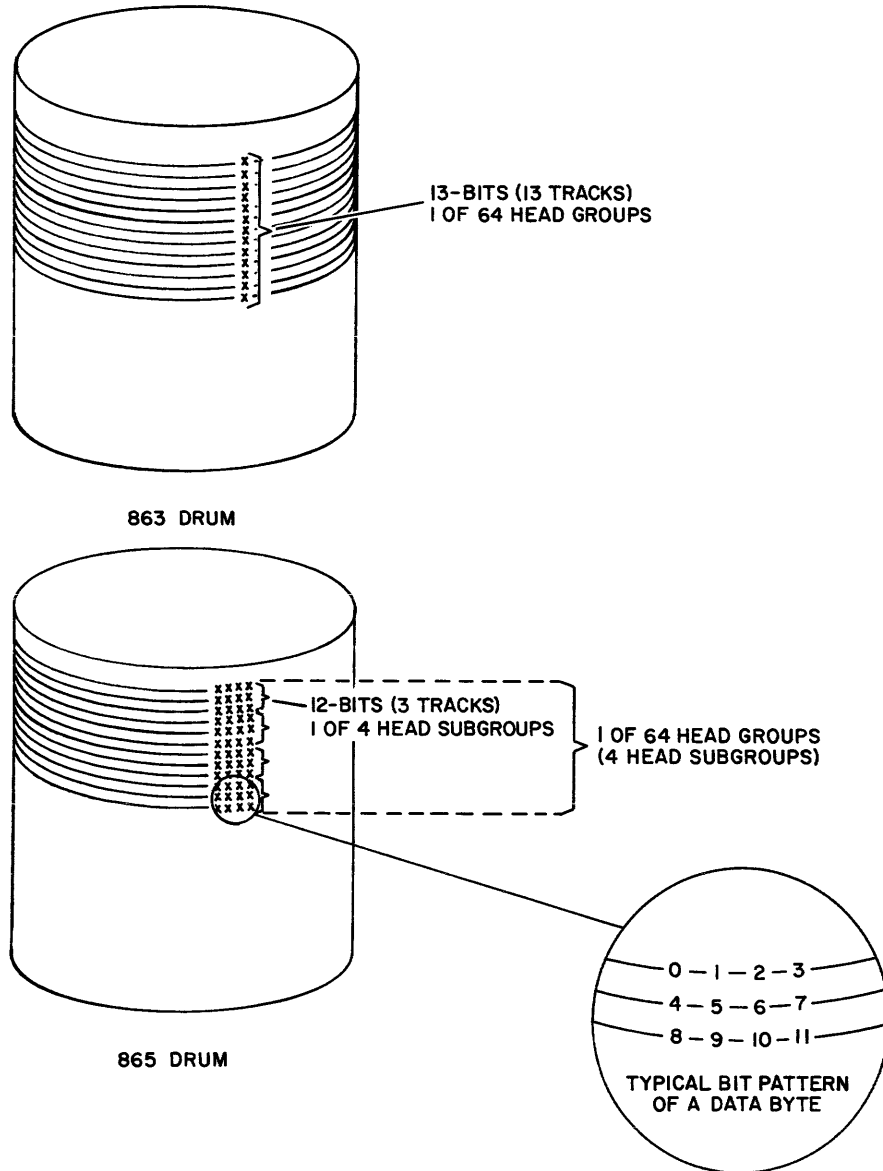

Figure A-2. Theoretical Byte Recording Format

865 Drum Units

In the 865 Drum Units each byte is recorded in 3 sets (tracks) of 4 bits each. The 3 sets are recorded in parallel with the 4 bits within each set recorded serially. A total of 128 bytes are recorded in each sector of the drum.

ADDRESS CHARACTERISTICS

Data is referenced by means of a 21-or 22-bit address.* The address is assembled in the controller from two 12-bit bytes sent via the data channel to the controller. In the 863 a 21-bit address designates the specific head group and angular position of the byte on the drum; in the 865, a 22-bit address specifies the head group, the head subgroup and the starting sector address.

Addresses are continuous throughout the drum. For multiple-byte (or sector) transfers the address is automatically augmented to select the next sequential byte (or sector) without the necessity of readdressing from the computer.

Address sequencing is continuous from the starting address to the end of the drum; however, operation is not end-around within a drum unit.

863 Drum Units

The data is byte addressable. Each 21-bit address references the head group and angular position of one of the 32,768 bytes within that head group.

865 Drum Unit

Data is sector addressable. The sectors are referenced by means of a 22-bit address. Each address references a head group, a head subgroup, and a sector within the head group.

DATA TRANSFER

The minimum data transfer is 1 byte† ; the maximum data transfer is an entire drum. Table A-1 lists the drum unit capacities and transfer information.

In the 865 Drum Unit data is transferred at a set rate of 1 byte every 2 microseconds. In the 863 Drum Unit data is transferred at a maximum rate of 1 byte per microsecond.

*Dependent upon the type of drum used in the subsystem. For specific format and address word information, refer to Addressing.

† Although as little as 1 byte may be read or written in the 865, the smallest addressable quantity is a sector (128 bytes)

The transfer rate is variable in the 863 Drum Unit, and can be reduced in binary increments by a logic interlace built into the drum unit. Table A-2 indicates the interlaces available along with the various byte transfer timing. The interlace is selected manually at each drum unit. Therefore, various 863 Drum Units in a subsystem may have independent data transfer rates.

TABLE A-1. DRUM CAPACITY AND TRANSFER SPECIFICATIONS

CAPACITY	863 DRUM	865 DRUM
	Data Bits	25,165,824
6-bit Characters	4,194,304	8,388,604
Tracks (data)	768	768
Bits/Track	32,768	65,536
TRANSFER		
Minimum Quantity	1 byte	1 byte*
Maximum Quantity	2,097,152 bytes	4,194,304 bytes
Maximum Rate	2,000,000 Characters/ second (1X1 interlace)	1,000,000 Characters/ second

TABLE A-2. INTERLACE SPECIFICATIONS

RATIO	TRANSFER RATE	
	μ sec/BYTE, MINIMUM	BYTE/SEC, MAXIMUM
1:1	1	1,000,000
2:1	2	500,000
4:1	4	250,000
8:1	8	125,000
16:1	16	62,500
32:1	32	31,250

Registers within the controller and drum unit are used for synchronization and buffering. Buffering limitations are explained under Buffer Timing.

* Although as little as 1 byte may be read or written in the 865, the smallest addressable quantity is a sector (128 bytes).

In the 865 Drum Unit the data channel must maintain the specified transfer rate or a Lost Data condition will occur. In the 863, data is never missed due to the failure of the data channel to maintain the selected interlace rate. If a byte is missed (either not received by the controller in time to be written on the drum or the last byte is not accepted from the controller when the next byte is ready to be read), the controller automatically enters a Readdress state during which the drum readdresses the location of the missed byte (the Address register is decremented and the address relocated). Accordingly, the drum must make one full revolution in order to relocate the desired position. (The 863 Drum Unit requires 34 ms per revolution.)

PERFORMANCE TIMING

The access and total operating time involved in a data transfer is equal to the sum of the times involved in addressing the drum, locating the address byte or sector (865), and performing the transfer.

Head Switching

Head switching time is defined as the interval necessary to electronically switch from one head group to another (or to the specified head group on an initial address operation). This is a constant, and is equal to 100 usec.

Latency Time

Latency time is defined as the interval between the end of head switching time and the point at which the addressed byte or sector (865) arrives under the R/W heads. This is a maximum of one revolution of the drum (33.4 ms); the average time is one-half revolution.

Access Time

Access time is defined as the time necessary to electronically switch to the desired head group plus the latency time necessary to locate the specified sector (865) or angular address (863); bring the desired data under the selected head group.

During multiple byte transfers which encompass more than one head group, the head switching takes place during the drum index time. Thus, additional access time is not required to reference the next sequential head group; however, the transfer time is increased by the 100 usec index time (see Programming Considerations; Write Timing).

CODES

Table A-3 lists all codes applicable to the drum storage subsystem. A complete explanation of each code follows the table.

TABLE A-3. CONNECT, FUNCTION, AND STATUS CODES

CONNECT	
Connect Controller and Drum	N00U*
FUNCTION	
Release and Disconnect	0000
Select Interrupt on Ready and Not Busy	0020
Release Interrupt on Ready and Not Busy	0021
Select Interrupt on End of Operation	0022
Release Interrupt on End of Operation	0023
Select Interrupt on Abnormal End of Operation	0024
Release Interrupt on Abnormal End of Operation	0025
Select Interrupt on Opposite Channel Release**	0026
Release Interrupt on Opposite Channel Release**	0027
Select Interrupt on Address Compare	0030
Release Interrupt on Address Compare	0031
Load Address	0040
Read	0041
Write	0042
Write Check	0043
Read Angular Count	0044
STATUS	
Ready	XXX1
Busy	XXX2
Drum Reject/Lost Data†	XXX4
Write Check Error	XX1X
End of Drum	XX2X
Release Interrupt**	XX4X
Address Compare Interrupt	X1XX
Interrupt on Ready and Not Busy	X2XX
Interrupt on End of Operation	X4XX
Interrupt on Abnormal End of Operation	1XXX
Read Parity Error	2XXX
Reserved**	4XXX

*N = equipment number of the controller. U = drum storage unit number.

**Not applicable to the 3436 Drum Storage Controller

† When operating with 3436/3637-A Controllers, this bit indicates a Drum Reject; with 3637-B Controllers, this bit indicates Lost Data.

CONNECT CODE

Connect Controller and Drum (N00U)

The 12-bit Connect code (Figure A-3) designates the equipment (controller) and the unit (drum) with which the computer desires to communicate.

Once the data channel is connected to a controller and drum unit, the controller and drum unit are reserved until specifically released by that channel. The channels may reserve additional drum units and/or controllers by issuing additional Connect instructions. Each Connect must receive a Reply for a successful connect and reservation to be made. If a Connect is rejected, the controller and/or drum is unavailable (non-existent or reserved by another channel).

NOTE

A Connect is never rejected because the subsystem is Not Ready.

When more than one connect is made (to reserve more than one drum unit), initiation of an I/O takes place at the controller and drum selected by the last successful Connect operation.

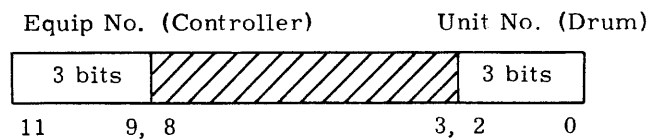

Figure A-3. Connect Code Format

Bits 0-2

These 3 bits designate the unit (drum) with which the program desires to communicate. The number designating the unit is variable from 0-7 by means of a rotary designation switch located in the drum unit.

Bits 3-8

Unused.

Bits 9-11

These 3 bits designate the equipment with which the program desires to communicate. The number designating the drum controller is variable by means of a rotary designation switch located in the controller cabinet.

Upon receipt of the Connect code by the controller, a Reply or Reject is returned to the data channel. If the desired controller and drum are available, a Reply is returned immediately. If the controller is unable to accept the code and perform the connect, a Reject is returned. Upon receipt of a Reject, the computer must request a status response and interrogate the status bits in order to determine whether the Reject was a result of the controller being reserved or the drum unit being unavailable. (Refer to explanation of status response bits Drum Reject (XXX4) and Reserved (4XXX).)

FUNCTION CODES

The four-digit octal function codes (Figure A-4) are divided into two major categories. The upper two digits of the code must be zeros; the categories are:

- 1) The mode codes (000 - and 004 -) which affect operating modes and,
- 2) The interrupt codes (002 - and 003 -) which set and remove interrupt selections.

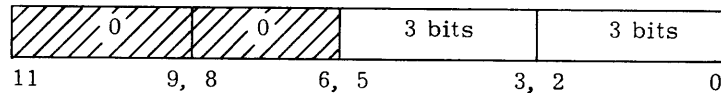

Figure A-4. Function Code Format

A Reject is issued upon receipt of a mode or release function code whenever the controller is busy (I/O in process).

Unassigned function codes are replied but ignored by the controller.

Mode Codes

The first code in this group (the Release and Disconnect (0000) code), while not actually a mode code, provides the computer with the means of releasing the drum subsystem and deselecting the data channel (without using a Master Clear), removing all reserves, mode selections and Interrupt signals. The remaining five codes in the group provide the computer with a means of selecting one of five operational modes. In the latter five cases, actual operation commences after the mode selection has been made and an I/O is initiated.

Transmission of a new select code prior to initiation of an I/O removes the present selection and replaces it with a new selection. In all cases, the select code is cleared upon completion of the mode of operation (end of I/O). Therefore, each individual buffer must be preceded by an operating mode code.

Release and Disconnect (0000)

This code releases the subsystem from the data channel. It causes all reserves to be removed, clears all Interrupt signals, removes all mode selections, clears the Read Parity and Write Check Error conditions, and drops the status response lines. (See Programming Consideration; Master Clear, Release and Disconnect.)

Load Address (0040)

This mode, in conjunction with an output buffer, causes the controller to load the next output buffer into the controller Address register.

Read (0041)

This mode, in conjunction with an input buffer, causes the controller to initiate a Read operation from the drum at the address specified by the content of the Address register. The operation will continue until halted by one of the conditions listed under Interrupt on End of Operation.

Write (0042)

This mode, in conjunction with an output buffer, causes the controller to initiate a Write operation to the drum at the address specified by the content of the controller Address register. The operation continues until halted by one of the conditions listed under the Interrupt on End of Operation.

Write Check (0043)

This mode, in conjunction with an output buffer, causes the controller to initiate a Read from the drum at the address specified by the content of the controller Address register.

The output buffer transmits data to the controller which is compared on a bit-by-bit basis with the data read from the drum.

Upon occurrence of a miscompare (compare error), the Write Check Error status bit is set. The occurrence of a write check error causes the Abnormal End of Operation interrupt to be set (if selected).

NOTE

The operation ends before the byte in error is replied; thus, in this case, the Address register contains the address of the byte in error.

Read Angular Count (0044)

This mode, in conjunction with an input buffer, causes the controller to return to the data channel a portion of the drum angular count. The count held in the Angular Counter is advanced by the drum unit Clock pulses and is synchronized with the rotation of the drum. Thus, the count (at any particular instant) represents the angular position of the drum in relation to the various address locations.

NOTE

The count returned is from the drum unit Angular Counter and is NOT the contents of the Address register.

The count returned to the data channel by the controller is dependent upon the type of drum unit selected.

- 865 Drum Unit: The controller returns the 7-bit sector address portion of the count presently associated with the data block being referenced.

The Angular Count is not timed with the beginning of the sector, and therefore the programmer cannot expect to operate on the next sector of the drum consistently. The program's next operation should be initiated on the returned address + 2. (See Address Compare Interrupt,)

- 861/863 Drum Unit: The controller returns the upper 12 bits of the 15-bit angular count. These 12 bits are sufficient to indicate within eight address positions (approximately 8 μ sec) the present position of the drum. If the input buffer is more than 1 byte in length, the count presently held in the continuously incrementing Angular Counter is returned on each byte transmitted.

The lower 15 bits of the 21-bit address indicate the angular address of a particular byte. The actual angular position of the byte on the drum depends upon

the interlace selected. To determine the physical location (angular position) of a particular byte address, the angular address portion of the byte address is left shifted, end-around, by the number of bits equal to the \log_2 of the interlace. An example follows:

Drum Interlace = 8-1	$\log_2 8=3$
Byte Address <u>2731465</u> ₈	Angular Address 31465 ₈
Head Address ↓	Angular Address = 011 001 100 110 101 ₂
Angular Address ↗	Physical Location = 001 100 110 101 011 ₂

Interrupt Codes

These codes establish and remove the interrupt selections which determine what conditions send an interrupt to the data channel. The codes are never rejected by the controller.

A manual Master Clear or channel Master Clear removes all interrupt selections.

Interrupt indications (interrupt active) are removed whenever a manual Master Clear, channel Master Clear, release, or any interrupt function (select or release) is performed. The indication (but not the selection) is also removed whenever a new mode of operation is selected.

Select Interrupt on Ready and Not Busy (0020)

Selection of this code causes the interrupt line to be activated and the associated status bit set the next time the subsystem becomes Ready and Not Busy (at the end of the next operation). (For an explanation of Ready and Not Busy conditions, refer to the associated status response bit description.)

Release Interrupt on Ready and Not Busy (0021)

This code removes the associated interrupt selection set up by the 0020 code. No interrupt notification of Ready and Not Busy will be sent until the condition is reselected.

Select Interrupt on End of Operation (0022)

This code causes the interrupt line to be activated and the associated status bit to be sent upon completion of the next operation whether the end of operation is normal or abnormal.

Normally, operation ends upon completion of a buffer; however, during Write operation, the End of Operation signal is delayed until completion of writing of the last byte on the drum. Although this is a fixed delay for the operation, the length of the delay is inherently dependent on the interlace being used, on the last address of the drum, and on whether a single byte is being written. (For specific times, refer to Program Considerations; Write Timing.)

Release Interrupt on End of Operation (0023)

This code removes the associated interrupt selections set up by the 0022 code. No interrupt indication of end of operation will be sent until the condition is reselected.

Select Interrupt on Abnormal End of Operation (0024)

This code causes the interrupt line to be activated and the associated status bit set upon the stopping of an operation due to any abnormal condition within the controller or drum unit.

The following conditions are considered abnormal:

- 1) The drum unit becomes Not Ready.
- 2) Any I/O attempt to reference an address exceeding the last address of the drum.
- 3) Occurrence of a read parity error (parity error in the data read from the drum).
- 4) Occurrence of a write check error (lack of a comparison during a Write Check operation).

Conditions 1 and 2 cause operations to cease immediately whether the interrupt is selected or not. If the interrupt is not selected, operation ends in a normal manner even though conditions 3 or 4 or both have occurred.

Release Interrupt on Abnormal End of Operation (0025)

This code removes the associated interrupt selection set up by the 0024 code. No interrupt indication of abnormal end of operation will be sent until the condition is reselected.

Select Interrupt on Opposite Channel Release (0026)

This code causes an Interrupt signal to be sent and the associated status bit set whenever the opposite data channel (the channel presently maintaining a Reserve state of the controller) releases its reservation of the controller and drum units.

NOTE

If only one data channel is connected to the controller (as in the 3436) this code is not applicable and should not be used.

NOTE

The interrupt is conditioned upon the dropping of the reserve. Therefore, a Master Clear causes the interrupt only if the data channel executing the Master Clear has the drum sub-system reserved.

Release Interrupt on Opposite Channel Release (0027)

This code removes the associated interrupt selection set by the 0026 code. No interrupt indication of a release by the other channel will be set until the condition is reselected.

Select Interrupt on Address Compare (0030)

This code causes the interrupt line to be activated and the associated status bit set upon occurrence (locating) of an address comparison between contents of the drum Angular Counter and the contents of the controller Address register.

When operating with an 863 Drum Unit, this interrupt operates in either of the following modes:

- 1) Upon detection of a specified address: if none of the 0041 through 0044 codes have been selected prior to location of the address, the interrupt occurs immediately.
- 2) Upon location of the specified address: if a mode is selected prior to location of the address, the interrupt is sent upon initiation of data transfer (I/O) at that address.

When operating with an 865 Drum Unit, this interrupt is conditioned only on the sector portion of the address. The interrupt occurs when the beginning of the specified sector is detected, and accordingly does not permit enough time for an operation to be initiated to that sector.

Release Interrupt on Address Compare (0031)

This code removes the associated interrupt selection set up by the 0030 code. No interrupt indication of an address comparison will be sent until the condition is reselected.

STATUS CODES

In order for the computer to determine the state of the controller and drums, a 12-bit status response is available to the data channel. The computer initiates a Copy Status instruction and samples the status response on the lines from the controller. The computer may sample a status response anytime it is connected, or after a connect attempt is rejected, even if the controller and/or drum unit are under control or reservation by a different data channel.

The Copy Status response bits (Table A-3) indicate the state of the controller and/or drums to which the data channel is connected or last attempted to connect. A "1" in the bit position indicates the condition is present (or has occurred); a "0" indicates the condition is not present (or has not occurred). It should be noted that the interrupts must have been selected or the associated interrupt status bit will be a "0" even though a condition that would normally set the interrupt has occurred (e.g., a copy status will not indicate that an abnormal end of operation has occurred unless the Abnormal End of Operation interrupt is selected). If the Abnormal End of Operation interrupt is selected, the operation ends, the Interrupt and Error status bits are set, and the interrupt is sent to the data channel immediately upon occurrence of the error condition. However, if the Abnormal End of Operation interrupt is not selected, the Error status bits are set immediately upon occurrence of the error condition even though the operation may not end until the buffer is completed (end of I/O).

Ready (XXX1)—Bit 0

The presence of this bit indicates that the drum unit that last connected is in an operable condition and ready for use. The drum is considered Ready when it is up to operating speed, all voltages are at proper operating levels, and no timing fault conditions exist. The bit will remain a "1" until the unit becomes inoperable or certain fault conditions occur (see Not Ready Causes).

Busy (XXX2)—Bit 1

The presence of this bit indicates that the drum unit specified by the Connect code is currently performing an operation (data transfer) and is unable to initiate any new action at this time. The bit will become a "0" at the end of operation.

The Busy status normally follows the Channel Busy signal; however, in a Write mode, the Busy status remains until the last byte has been written on the drum, or in the case of the 865, until a checkword has been written or read. Any abnormal condition which causes an end of operation to occur causes the Busy status to drop.

The Busy status does not respond to buffers attempted on a unit which is Not Ready or to buffers which are inconsistent with the selected mode of operation or for which no mode of operation has been selected (e. g. , attempting to initiate an output buffer when a Read mode is selected).

Drum Reject/Lost Data (XXX4)—Bit 2

Dependent upon the controller model used in the subsystem, this bit indicates:

- 3436/3637-A Controllers - Drum Reject

The presence of this bit indicates that the instruction has been rejected because the specified drum unit was unavailable. This bit will be a "1" whether another controller is actually using the unit or simply has it reserved. The bit will also become a "1" if the unit specified by the code does not exist (no drum unit has that unit designation switch setting).

- 3637-B Controller - Lost Data

The presence of this bit indicates that data has been lost due to the data channel's failure to maintain the specified transfer rate to the 865 Drum Unit, or that the starting byte address was unequal to zero upon initiation of an I/O operation, (this bit is not used when 861/863 Drum Units are attached to this controller).

Write Check Error (XX1X)—Bit 3

The presence of this bit indicates that a miscompare has occurred during a Write Check operation. The bit is a "0" from initiation of the operation until the completion of the operation, providing the record compares for the entire buffer. If a miscompare is detected, the bit becomes a "1" immediately, and operation ceases if the Abnormal End of Operation interrupt is selected.

End of Drum (XX2X)—Bit 4

The presence of this bit indicates that: 1) with 3436/3637-A Controllers, the drum unit has addressed and used the final address on the drum. The bit remains a "1" until the subsystem is readdressed or master cleared (a MC clears the Address register to 00000) or, 2) with 3637-B Controllers, that the operation being initiated on the drum is attempting to go end-around on the drum. (Refer to section on Addressing).

Release Interrupt (XX4X)—Bit 5

The presence of this bit indicates that the interrupt was caused by the other data channel releasing its reserve of the controller and/or drum units.

Address Compare Interrupt (X1XX)—Bit 6

The presence of this bit indicates that the interrupt was caused by an existing comparison between the content of the controller Address register and the drum angular position (see 0030 Interrupt on Address Compare).

Interrupt on Ready and Not Busy (X2XX)—Bit 7

The presence of this bit indicates that the interrupt was caused by the specified condition, i. e., the drum unit is in the Ready state and is not currently Busy.

*Interrupt on End of Operation (X4XX)—Bit 8**

The presence of this bit indicates that the interrupt was caused by an End of Operation.

*Interrupt on Abnormal End of Operation (1XXX)—Bit 9**

The presence of this bit indicates that the interrupt was caused by an Abnormal End of Operation.

Read Parity Error (2XXX)—Bit 10

The presence of this bit indicates that either a parity or checkword error has been detected in the data read from the drum during a Read or Write Check operation. When an 865 Drum is selected, the occurrence of a transmission parity error between the controller and drum unit also causes this bit to set.

Reserved (4XXX)—Bit 11

Dependent upon the controller model used in the subsystem, this bit indicates:

- For 3436/3637-A Controller: The presence of this bit indicates that the instruction has been rejected because of the Reserved condition. If the status occurs without the Drum Reject status bit set, it indicates that the controller is reserved by the other data channel. If the status occurs with the Drum Reject bit set, it indicates that the controller is not reserved by the other channel but that the desired drum unit was reserved or unavailable.

*For an explanation of an End of Operation and an Abnormal End of Operation, see interrupt function codes 0022 and 0024.

- For 3637-B Controllers: The presence of this bit indicates that the instruction has been rejected because the controller is reserved by the other data channel. If the bit is a zero after a connect is rejected, it indicates that the controller is not reserved by the other channel but that the desired drum unit was reserved or unavailable.

SUBSYSTEM ERRORS AND PERFORMANCE

The controller is designed to recognize lost data, parity, and write check errors. Other internal drum errors cause the subsystem to go to the Not Ready state. The write check, lost data, and read parity errors may be detected through the use of interrupts and the Copy Status instruction.

LOST DATA ERROR

This error and associated status bit is applicable only when operating with an 865 Drum Unit. The error occurs (and the associated status bit sets) whenever:

- A data transfer is initiated anywhere other than at the start of a sector.
- The data channel fails to maintain the required transfer rate between the channel and controller/drum unit.

Upon occurrence of a Lost Data error condition, all further data transfer (within the operation) ceases and an Abnormal End of Operation occurs. If selected, the Abnormal End of Operation Interrupt sets.

PARITY ERRORS

The controller is designed to recognize two distinct types of parity errors:

- 1) A parity error associated with the byte received from the data channel, called a Transmission Parity Error.
- 2) A parity error associated with the data read from the drum, called a Read Parity Error.

The Read Parity Error and Transmission Parity Error circuits are independent of one another. The data transfer circuits within the controller are designed so that the

occurrence of one type of error does not cause the occurrence of the other, (i. e., occurrence of either type of error causes the controller to correct (toggle) the parity bit prior to transferring the byte).

Read Parity Error

During Read or Write Check (special type of Read) operation, a check is made on the data read from the drum. If an error is detected, the Read Parity Error FF sets, causing the associated parity error indicator to light and status bit to set. If selected, the Abnormal End of Operation Interrupt occurs and that status bit is set. In the case of the 861/863 drums it indicates that a parity error was detected in the data byte read from the drum. In the case of the 865 it indicates that either a checkword error was detected in association with the sector read from the drum or a parity error was detected in the data transferred between the drum and the controller.

NOTE

The Read Parity Error FF and status bit remain set until a new operation is initiated.

Transmission Parity Error

The Transmission (XMSN) Parity circuits examine each byte transmitted to/from the controller, generate a new parity bit for that byte, and compare the parity bit generated with the parity bit accompanying the byte. If the bits do not agree, the Transmission Parity Error indicator lights up. Transmission of the error indication to the data channel is dependent upon the code or data causing the error as follows:

XMSN Parity Error on Connect: If the error is detected in conjunction with a Connect code, the connect and status drop, no action is taken by the controller upon the code in error, the TRANSMISSION P/E indicator (XMSN) lights up; however, no Reply, Reject, or Transmission Parity Error signals are sent to the data channel.

XMSN Parity Error on Function: If a Transmission Parity Error occurs in conjunction with a function code, the XMSN Parity Error signal is enabled to the data channel and the error indicator lights up; however, the function code is ignored by the controller. (No Reply or Reject is sent).

XMSN Parity Error on Data Transfer: If a Transmission Parity Error is detected on a data byte received from or transmitted to the data channel, the XMSN Parity Error signal is enabled and the error indicator lights up. Transfer of the byte in error continues in the normal manner.

The 865 Drum Unit also checks and generates parity for each byte transmitted to or received from the controller. (Parity bits are not written on or read from the 865 drum; only the checkword is used for data error detection.)

In the 863, if a Transmission Parity Error occurs during a Write operation, the parity bit of the byte in error is toggled and the byte in error along with the toggled parity bit is transferred to and written on the drum. If a Read Parity Error occurs during a Read operation, the parity bit in error is toggled and the byte in error, along with the corrected parity bit is transferred to the data channel. (Toggling of the parity bit has the effect of correcting the parity error, not the byte, so that the byte in error does not cause a parity error to be detected in the opposite parity circuit as the byte in error is transferred.)

NOTE

Once the parity bit is toggled and the byte transferred, all indication of the byte in error is removed (except as noted under Read Parity Error). Thus it becomes the responsibility of the programmer to maintain the knowledge and indication of the byte in error and its location on the drum (in the case of a Write) or in the computer (in the case of a Read) in order to avoid inadvertent use of the data in error.

Only a master clear clears a Transmission Parity Error in the 3436/3637-A Controllers; any MC or new Connect operation clears the Transmission Parity Error in the 3637-B Controller.

NOT READY CAUSES

The drum subsystem becomes Not Ready only when the associated drum unit is Not Ready. The drum is Not Ready when any of the following conditions exist:

- The drum is not up to operating speed.
- Any abnormal voltage levels exist in the dc circuits.
- A timing error exists or has been detected.

If the system becomes Not Ready during a data transfer, an abnormal end of operation is generated (the End of Operation and/or the Abnormal End of Operation interrupts are set if selected). The Not Ready status is removed by a manual master clear only.

BUFFER TIMING*

The following indicates the buffer timing** available to the data channel when operating with 863 Drum Units. If the channel fails to operate within these times the controller automatically enters a Readdress state during which the drum readdresses the location of the missed byte (the Address register is decremented and the address relocated). Accordingly, the drum must make one full revolution in order to relocate the desired position. (The 861/863 Drum Unit requires 34 ms per revolution.)

Timing of transfers within the drum subsystem is determined by the drum unit timing. The timing is referenced at the start of a Write cycle (for Write operations) or the start of a Read cycle (for Read and Write Check operations).

- 1) Minimum data signal to Reply time is 0.1 microseconds for Read and Write operations and 0.16 microseconds for Write Check operations.
- 2) The time from the dropping of the data signal to the dropping of the Reply is constant at 0.04 microseconds.
- 3) Byte timing is dependent on the interlace selected. The time between bytes is equal to the interlace rate in microseconds.

Write Timing

- 1) The data signal must occur no later than 0.08 microseconds before the start of the associated Write cycle.
- 2) The earliest a Reply can occur for the data signal of a given byte is 1.1 microseconds following the start of the Write cycle of the preceding byte plus one (i. e., the earliest a Reply can occur for Byte C is 1.1 microseconds after the start of the Write cycle for Byte A). Refer to Figure A-5.
- 3) Figure A-6 shows holding registers during Write operations.

*Not applicable to 865 Drum Units.

**All times are taken from the controller cable interface.

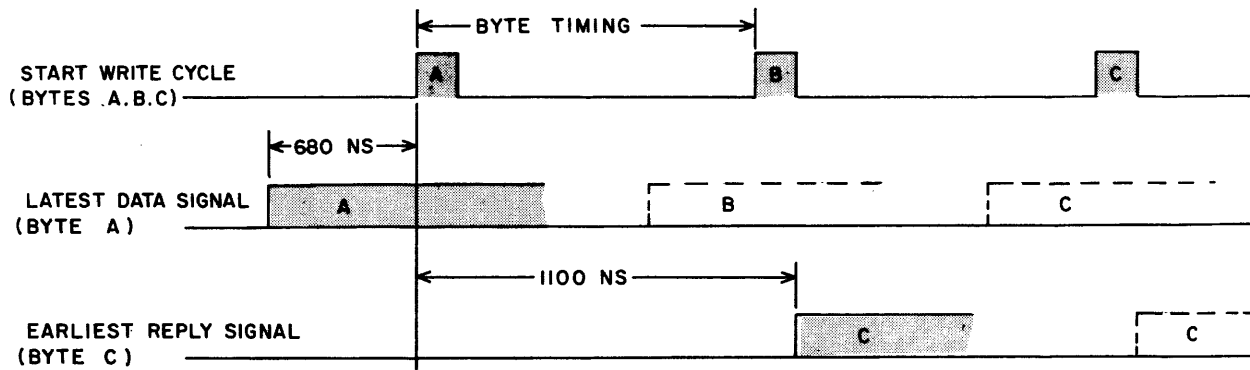

Figure A-5. Write Timing

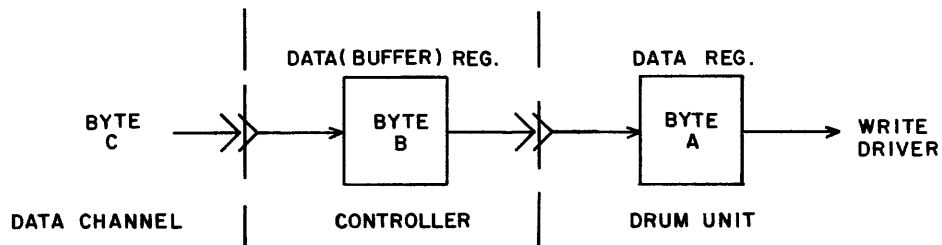

Figure A-6. Holding Registers During Write Operations

Read and Write Check Timing

- 1) The Data Signal for a byte must drop (indicating data channel acceptance of the byte) at least 0.05 microseconds before the start of the Read Reply sequence for the following byte.
- 2) The earliest a Reply can occur is 0.34 microseconds for a Read operation and 0.4 microseconds for a Write Check following the start of the Read Reply sequence for that byte (refer to Figure A-7).
- 3) Figure A-8 shows the holding register during Read/Write Check operation.

ADDRESSING

After transmitting the Connect code, the computer may transmit an operating mode code or a Load Address mode code. If the operation is to start or continue at the address location presently held in the controller register, an operating mode select code is sent immediately upon completion of the connect. The address currently held in the

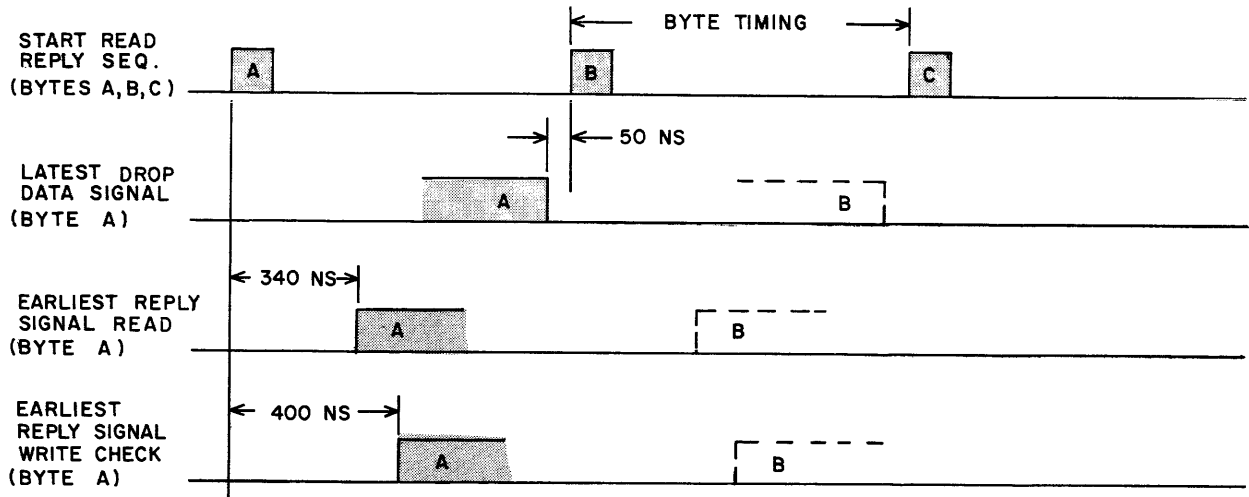

Figure A-7. Read/Write Check Timing

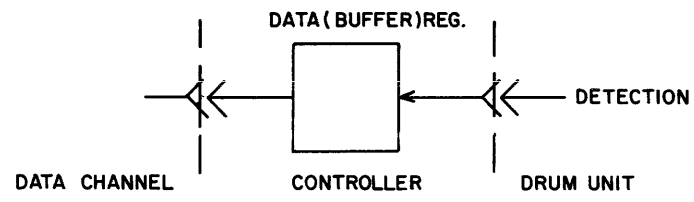

Figure A-8. Holding Register During Read/Write Check Operation

register is the one at which the next Read or Write operation will take place. It is automatically incremented after each byte is either written on or read from the drum except on detection of a write check error. This process takes place throughout the entire drum, from head group 0, angular address 00000, to and including the last address on the drum (head group 64, angular address 32,768). If the Input/Output operation attempts to cause incrementation to continue beyond the last address available, an Abnormal End of Operation condition occurs. Once the last address has been used, the Address register must be reset. This may be done by loading a specific address or by executing a manual Master Clear or a Clear Channel instruction. In the latter two cases, the register is set to zero. If, however, a new address is necessary for the next operation, the Load Address mode code must be sent to the controller.

On receipt of the Load Address code, the controller commences loading 12-bit bytes from the data channel. These bytes form a 21-or 22-bit address word (dependent upon the type of drum unit selected) which is automatically loaded into the Address register

by the controller. The first byte of the address is loaded into the upper portion of the register (the lower order 9 or 10 bits of the byte are loaded into the register; the upper 2 or 3 bits are discarded). The second byte is loaded into the lower portion of the register. The output buffer from the computer may be as long as desired. The controller continues to load the bytes into the Address register as previously described until the buffer is depleted. Thus, the last 2 bytes transferred comprise the address remaining in the Address register.

NOTE*

Because all byte address locations are absolute regardless of the interlace being used, the programmer is normally concerned only with the byte address of the desired data and not with the angular location of the byte upon the drum. The only time the programmer is ever concerned with the true angular location of a byte is in conjunction with Read Angular Count (0044). In this case, the angular position is desirable in order to determine the physical position of the drum read/write heads in relation to several unrelated byte address locations such that the closest location can be addressed first, the next closest location addressed next, etc., thus reducing the overall access and transfer time.

Figure A-9 and A-10 show the format of the drum unit addresses. The 863 address specifies one of 64 Head Groups and the angular address of a byte within that Head Group. The 865 address specifies one of 64 Head Groups, one of four Head Subgroups within the Head Group, one of 128 sectors in the Head Subgroup, and one of 128 bytes in the sector.

863 FORMAT

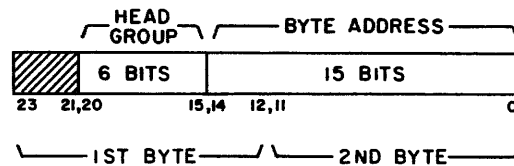

Figure A-9. 863 Drum Address Format

*Not applicable to 865 Drum Units.

Bits 0-14 specify one of $100,000_8$ ($32,768_{10}$) angular addresses within a particular head group.

Bits 15-20 specify one of 64 Head Groups on the drum.

Bits 21-23 (NOT USED).

865 FORMAT

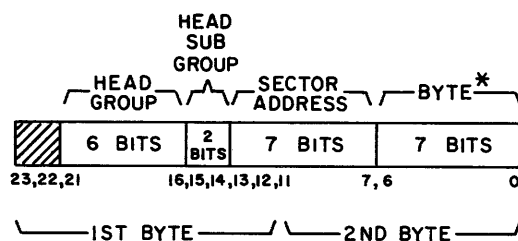

* MUST CONTAIN ALL ZEROS.

Figure A-10. 865 Drum Address Format

Bits 0-6 specify one of 128 bytes in a sector. When loading addresses, these 7 bits must all be zeros or a Lost Data error will occur immediately upon initiation of an I/O operation.

Bits 7-13 specify one of 128 sectors in a particular Head Sub-group.

Bits 14, 15 specify one of four Head Sub-groups in a particular Head Group. Each Head Sub-group consists of three tracks in which the 12-bit byte is to be written (or read).

Bits 16-21 specify one of 64 Head Groups on the drum.

Bits 22, 23 (NOT USED).

NOTE

3000 Series Computers disassemble words upper byte first.

During multiple-byte or record transfers, (buffers of more than one byte or sector in length), the address is automatically augmented to select the next sequential location.

This process takes place throughout the entire drum, up to and including (but not beyond) the last address of the drum. (Operation is not end-around within a drum.)

Auto-loading/End of Record

In order to accommodate auto-loading, the drum subsystem is equipped to indicate an End of Record upon completion of the autoloading sequence.

Auto-loading causes the drum subsystem to send to the data channel 512 bytes of data, commencing at address zero of the specified drum unit. Upon completion of the data transfer, the subsystem transmits an End of Record signal in response to the 513th byte.

NOTE

Because the 863 drum is byte addressable, there is no specific record length for the subsystem. The End of Record signal is provided only to facilitate auto-loading and is issued in response to an Autoload Request (see below).

The subsystem is designed to recognize the following sequence as the Auto-load Request and responds accordingly:

- 1) Master Clear.
- 2) Connect.
- 3) Issuance of a 0041 (Read) function code.
- 4) Initiation of a buffer equal to or greater than 513 bytes.

PROGRAMMING CONSIDERATIONS

The following information will help in making the programmer and the engineer aware of critical problems and procedures unique to drum subsystems. Most of the procedures are common to all computers; those that are unique to a particular computer are so stated.

PROGRAM COMPATABILITY

Program compatibility exists between programs written for the 3436/3637-A controllers and the 3637-B controllers with only minor variations necessary to the original program. These changes are limited to the differences in the Drum Reject/Lost Data

and Reserved status bits and addressing. Thus any program written for a 3436/3637-A controller will operate with a 3637-B controller by altering all references in the original program to these two status bits so that they reflect the new meaning as defined for the 3637-B controller and (when operating with an 865) by ensuring that all addresses reference the beginning of a sector. The converse is also true, except that any program written for a 3637-B controller and operating with an 865 Drum Unit cannot be modified to operate with a 3436/3637-A controller.

865 INPUT/OUTPUT OPERATIONS

When any I/O operation to an 865 Drum Unit is terminated anywhere other than at the end of the sector (less than 128 bytes have been read or written), the byte count portion of the Address register will not contain all zeros. Accordingly, the register must be reloaded with an address whose byte count portion equals zero before any new I/O operation may commence.

SIMULTANEOUS SELECTION

If the two data channels attached to the same controller simultaneously attempt to connect to the controller, neither channel is given preference; the controller connects to the data channel recognized first.

Initiation of the I/O need not take place immediately after the connect is made; once the connect is made, the channel has the controller reserved until specifically released by the channel.

BUFFER RESTRICTIONS

Each buffer must be preceded by an EF instruction which specifies a mode of operation. Completion of a buffer (end of operation) with or without chaining clears the previous mode selection. Buffers which are inconsistent with the mode selected cause the computer to hang up (i. e. , initiation of an output (write) buffer when a Read mode is selected).

MASTER CLEAR, RELEASE AND DISCONNECT

A manual or programmed (channel) Master Clear causes the Address register to be cleared to zero and removes all interrupt selections. A Release and Disconnect has no effect on the content of the Address register or interrupt selections.

NOT READY

A manual Master Clear is necessary to remove a Not Ready condition.

INTERRUPTS

Once an interrupt occurs (if selected), it is removed by any Master Clear, the Release and Disconnect function code, or any 002-, 003- function code. The interrupt selections are independent for each data channel interface and are not affected by the actions of the other data channel.

NOTE

All interrupt selections are saved (remain) within the interface when a release and disconnect is performed. Only a Master Clear and associated 002- or 003- codes remove interrupt selections.

A data channel which has the subsystem reserved receives all interrupts selected. The channel not in control (reservation) of the controller and/or drums can be interrupted by a release interrupt only. All other interrupts from the controller to the data channel not in control are inhibited even though the interrupt is selected.

WRITE TIMING

During Write operations, the End of Operation signal is delayed until completion of writing of the last byte of the buffer or record. In the 863 Drum Units the length of this delay depends on three factors: 1) the interlace ratio, 2) whether the last byte of the buffer requires a different head group, and 3) whether a single byte is being written (1-byte buffer).

Write Timing Interlace Delay (863 Drum Units)

This delay time is equal to the transfer time per byte, and is directly proportional to the interlace ratio:

<u>Ratio</u>	<u>Transfer Time (μsec/byte)</u>
1:1	1
2:1	2
4:1	4
8:1	8
16:1	16
32:1	32

Last Byte Write Timing

If the last byte of the buffer requires a head group on the drum different than the group used for the preceding byte, the end of operation is delayed by the 100- μ sec head group switching time plus the interlace time mentioned above.

Single Byte Write Timing

If only a single byte is to be written on the drum (one-byte buffer), the end of operation is not sent until the byte has been written. Since the desired address position must be located prior to initiating the Write operation, the delay may be equal to an entire revolution of the drum (35 ms).

MANUAL OPERATIONS

Operation of the drum subsystem is under program control from the computers through the use of the EF Connect and function codes. Only those manual operations necessary to bring up power to the controller and drums, set the equipment and unit designation switches, and load and initiate the computer program are necessary for subsystem operation.

To bring the subsystem up from dead start (no power applied to drums or controller), one of the following procedures should be followed. Refer to Figure A-11 for switch locations.

REMOTE STARTING

- 1) Ensure that the REMOTE-LOCAL power switch at each drum unit is in the REMOTE position.*
- 2) Turn the main power circuit breaker (located near the bottom of the power panel at the rear of the controller) on. (The drum units will automatically be sequenced to avoid circuit overloading by starting current surges.)

LOCAL STARTING

- 1) Ensure that the REMOTE-LOCAL switch at the drum unit is in the LOCAL position.
- 2) Press the power ON switch located immediately above the REMOTE-LOCAL switch. Wait approximately 10 minutes (to allow starting current surge to die down) and then repeat steps 1 and 2 for the next drum unit.

NOTE

During remote starting, the sequencing automatically bypasses any unit in the subsystem whose selection switch is in the LOCAL position. Any combination of REMOTE and LOCAL settings is permissible in a subsystem.

NOTE

In the REMOTE position, the presence of dc power at the controller is the determining factor in sequencing of power on at the drum units. When dc power becomes available at the controller, the drum units selected for remote power on starting automatically commence sequencing. Thus, it is possible to wire the system for automatic remote starting from the computer (or other desired source) rather than the controller by supplying controller power from a switch at the desired remote location.

*When the switch is in the REMOTE position, pressing the POWER ON or POWER OFF switch on the drum unit maintenance panel has no effect on the drum unit. When the switch is in the LOCAL position, the drum unit is not affected by the controller main power source.

Each drum unit requires approximately 15 minutes to come up to speed and become Ready. Thus, in a full eight drum subsystem (set up for Remote starting) two hours are required to bring the entire subsystem to the Ready state. If the subsystem is set up for Local starting, it will be up to speed and Ready, 15 minutes after the last drum is started.

Before turning the subsystem on, ensure that all switches are properly set. Table A-4 indicates the correct setting of the various switches for normal subsystem operation. Deviations from the settings indicated (except as noted) are for maintenance purposes only and must not be used for normal programming operations.

To shut down the subsystem, turn off the appropriate power switch. If the units in the subsystem are selected for remote operation, all units drop simultaneously (no sequencing is necessary when shutting down the system). If any unit is selected for local operation, press the associated unit power OFF switch.

NOTE

When power is first supplied to the subsystem (controller and/or each drum unit), an automatic clear is performed on the controller and the drum unit logic. (The data on the drum is not disturbed.)

Prior to initiation of the program, the equipment and unit designation switches must be set. Figures A-11 and A-12 show the switches on the cabinets. No provision is made for indications of redundant selections (more than one equipment or unit having the same select setting).

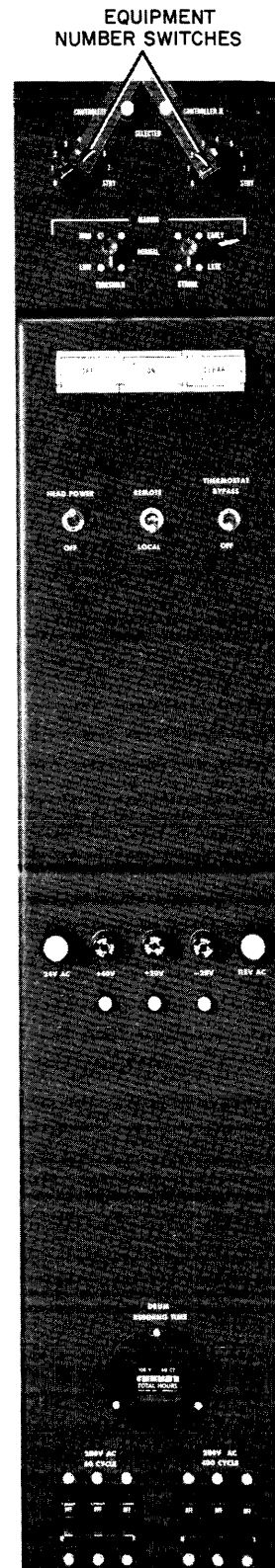

1492

Figure A-11. Drum Unit Switches and Indicators

1513

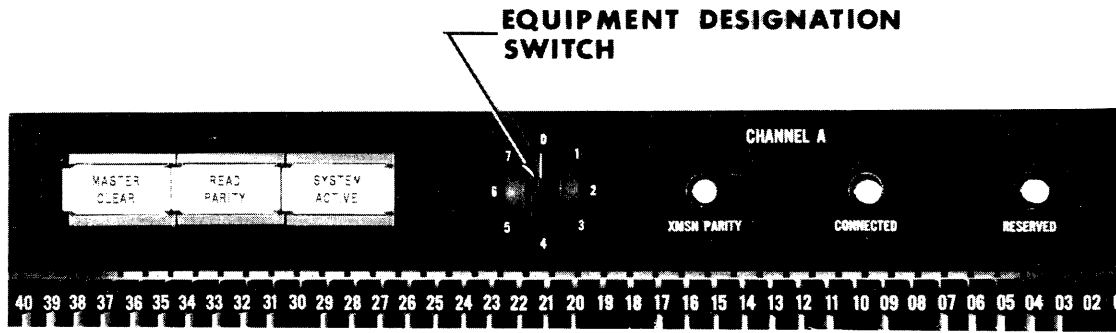

Figure A-12. Controller Interior Switches and Indicators

TABLE A-4. SWITCHES AND INDICATORS

ITEM*	DESIGNATION	NORMAL SETTING (Indication)	LOCATION**
DRUM UNIT			
I	OFF LINE	OFF	Exterior
I	CIRCUIT BREAKER	OFF	Exterior
I	THERMOSTAT BY-PASS	OFF	Exterior
I	LOW TEMP	OFF	Exterior
I	HIGH TEMP	OFF	Exterior
R	CONTROLLER I	0-7	Control Panel
R	CONTROLLER II	0-7	Control Panel
I	CONTROLLER I SELECTED	ON (If selected)	Control Panel
I	CONTROLLER II SELECTED	ON (If selected)	Control Panel
MARGIN Switches†			
T	THRESHOLD	NORMAL	Control Panel
T	STROBE	NORMAL	Control Panel
PI	OFF	OFF (Not lighted)	Power Chassis
PI	ON	ON	Power Chassis
PI	CLEAR	OFF	Power Chassis
T	HEAD POWER	ON	Power Chassis
T	REMOTE/LOCAL	Appropriate setting for desired power sequencing	Power Chassis

*I = Indicator P = Pushbutton switch
 R = Rotary switch T = Toggle switch

**All switches and indicators located within associated cabinets except those marked exterior.

† Not used on 865 Drum Units.

TABLE A-4 (Cont'd)

ITEM	DESIGNATION	NORMAL SETTING (Indication)	LOCATION**
DRUM UNIT (Cont'd)			
T	THERMOSTAT BY-PASS	OFF	Power Chassis
I	+40v	ON	Power Chassis
I	+20v	ON	Power Chassis
I	-20v	ON	Power Chassis
T	208 vac 60~(Circuit breaker)	ON	Power Chassis
T	208 vac 400~(Circuit breaker)	ON	Power Chassis
CONTROLLER			
I	CIRCUIT BREAKER	OFF	Exterior
I	THERMOSTAT BY-PASS	OFF	Exterior
I	LOW TEMP	OFF	Exterior
I	HIGH TEMP	OFF	Exterior
PI	MASTER CLEAR	OFF	Chassis 1
I	READ PARITY	OFF	Chassis 1
I	SYSTEM ACTIVE	ON (When busy)	Chassis 1
R	EQUIPMENT DESIGNATION	0-7	One on each channel chassis (Channel A, Chassis 1) (Channel B, Chassis 2)
I	TRANSMISSION PARITY	OFF	
I	CONNECTED	ON (If connected)	
I	RESERVED	ON (If reserved)	
T	208 vac 400~ (Circuit breaker)	ON	Power Chassis (Rear of Cabinet)
T	CB1 (24 vac Circuit breaker)	ON	Main Frame
T	THERMOSTAT BY-PASS	OFF	Main Frame

SAMPLE PROGRAM ROUTINE

To help in understanding the drum subsystem, a sample program is included preceded by a flow chart of the program. The routine is designed for a 3600 Computer System operating with an 863 Drum Unit.

PROGRAM SEQUENCE

The basic programming sequence is:

SEQUENCE	COMMENT
1. Connect	Connect code selects controller and drum unit (if available).
Connect Response	If the Connect operation is successful, a Reply is returned; if the connect is not made (controller or drum unavailable) a Reject is returned; return to step 1 after determining the cause of the reject.
2. Select Interrupts	Any desired interrupting conditions should be selected at this point.
3. Load Address	If a new address location (other than the one presently held in the controller Address register) is desired, it should be sent prior to the execution of an EF operating mode selection.
4. Select Operating Mode	EF code selects the desired mode of operation. (Operating modes must be selected for each individual buffer.)
5. Initiate Operation	Initiation of a read or write I/O initiates operation within the drum. Completion of the I/O may be detected through use of the End of Operation interrupt or dropping of the Busy status bit.

PROGRAM

This program uses two Stop switch settings and a Selective Jump switch setting. If Stop switch 3 is set, the program halts after typing out the error comment. If the switch is not set, the program continues even if an error is detected unless the error is a write check error. In this case, the program automatically initiates a read of the data in which the error occurred. If Stop switch 2 is set, the program stops upon completion of the routine. If the switch is not set, the routine is reinitiated at the load address point. In this latter case, operation is continuous and end-around within the program until stopped manually or until an error condition is detected. If Selective Jump switch 3 is set, the program bypasses the error typeout.

This routine selects controller (equipment) number 0, drum (unit) number 0. (The program assumes that the controller is connected to Channel 10.) The program then loads an address and initiates a Write operation of 1000₈ 48-bit words. Then a Write Check operation is initiated on the data just written.

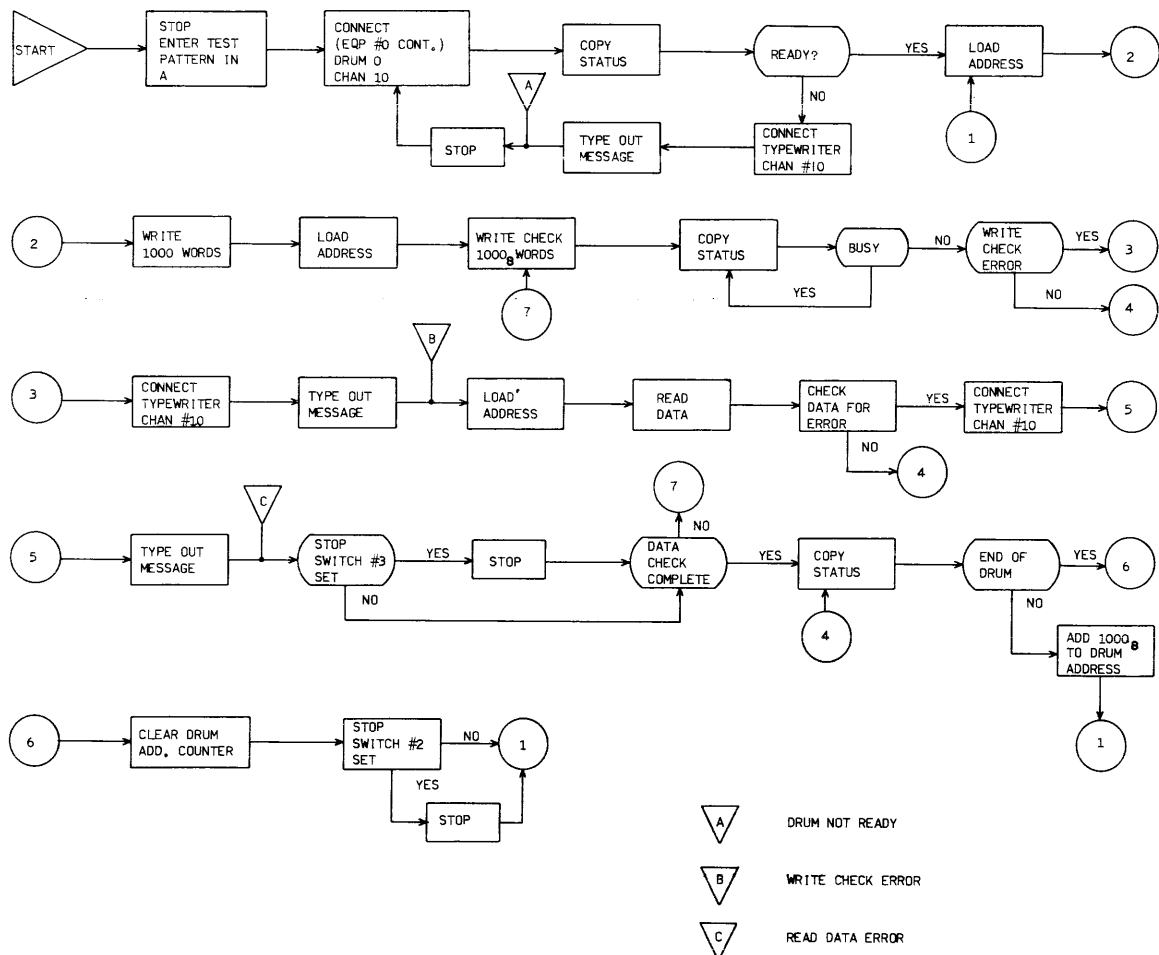

Program Length 02101

00000	10	0	00000		ENA	0	
	20	0	P00067		STA	DRAD	Clear drum address counter
00001	76	0	P00002		SLS	ST1	Put pattern to be written in A
	50	0	00000				
00002	20	1	P00101	ST1	STA	WRTDA, 1	Store pattern in write buffer
	50	0	00000				
00003	54	1	01411	+	ISK	777, 1	
	75	0	P00002		SLJ	ST1	
00004	74	0	P00004	BEGIN	CONN	10B, 0, 0,*	Wait drum reply on connect
	10	0	00000				
00005	74	4	11000		COPY	10B, 1	Copy status
	10	0	00000				
00006	63	0	02001		NBJP	B1, 1, T1	Is drum ready
	60	0	P00011				
00007	10	0	P00061		ENA	NRTY	Cont word add type out not ready
	75	4	P00046		RTJ	TYPE	Go to typeout
00010	76	0	P00004	+	SLS	BEGIN	
	50	0	00000				
00011	75	4	P00054	T1	RTJ	LDAD	Go to load address
	50	0	00000				
00012	74	1	P00012		EXTF	10B, 42B,*	Wait reply on write function
	10	0	00042				
00013	74	3	P00013		BEGW	10B, WDATA,*	Wait reply on write
	10	0	P00065				
00014	75	4	P00054		RTJ	LDAD	Go to load address
	50	0	00000				
00015	74	1	P00015		EXTF	10B, 43B,*	Wait reply on write check fun
	10	0	00043				
00016	74	3	P00016		BEGW	10B, WDATA,*	Wait reply
	10	0	P00065				
00017	74	4	11000	T3	COPY	10B, 1	Copy status
	10	0	00000				
00020	63	0	02001	+	NBJP	B1, 1, T3	Wait not busy
	60	0	P00017				
00021	63	0	02003	+	NBJP	B1, 3, T8	Jump if no write check error
	60	0	P00040				

00022	10	0	P00062	+	ENA	WCTOC	Cont word add type wrt ck error
	75	4	P00046		RTJ	TYPE	Go to type out
00023	75	4	P00054		RTJ	LDAD	Load address
	50	0	00000				
00024	74	1	P00024		EXTF	10B, 41B,*	Wait reply to read function
	10	0	00041				
00025	74	2	P00025		BEGR	10B, RDATA,*	Wait reply
	10	0	P00066				
00026	74	4	11000	T5	COPY	10B, 1	Copy status
	10	0	00000				
00027	63	0	02002	+	NBJP	B1, 2, T5	Wait not busy
	60	0	P00026				
00030	50	1	00000		ENI	0, 1	Clear B1
	50	0	00000				
00031	12	1	P00101	T6	LDA	WRTDA, 1	Load write data
	42	1	P01101		SCM	REDDA, 1	Complement by read data
00032	22	0	P00037		AJP, ZR	T7	If A equal zero, continue
	10	0	P00063		ENA	REDECW	Control word for data error type
00033	75	4	P00046		RTJ	TYPE	Go to type
	50	0	00000				
00034	10	1	00000	+	ENA	0, 1	Put count in A
	14	0	P00067		ADD	DRAD	Add present drum
00035	00	7	00555		RSW	A, D	Put failing Drum Address in D
	12	1	P01101		LDA	REDDA, 1	Failing Read Word
00036	16	1	P00101		LDQ	WRTDA, 1	Write word
	76	3	P00037		SS3	T7	Data error
00037	54	1	00777	T7	ISK	777B, 1	Data check counter
	75	0	P00031		SLJ	T6	
00040	74	4	11000	T8	COPY	10B, 1	Copy drum status
	10	0	00000				
00041	63	0	02004		NBJP	B1, 4, T9	Check for end-of-drum
	60	0	P00044				
00042	10	0	00000		ENA	0	
	20	0	P00067		STA	DRAD	Clear drum address counter
00043	74	2	P00011		SS2	T1	End of test stop if S2 set
	50	0	00000				
00044	10	0	01000	T9	ENA	1000B	
	70	0	P00067		RAD	DRAD	Add 1000 to drum address

00045	75	0	P00011		SLJ	T1	
	50	0	00000				
00046	75	0	P00046	TYPE	SLJ	*	
	75	3	P00046		SJ3	TYPE	If JP3 set bypass typeout
00047	61	0	P00051		SAL	TYP1	Store control word address
	50	0	00000				
00050	74	0	P00050	+	CONN	0, 5, 0, *	Connect typewriter
	00	0	05000				
00051	74	3	P00051	TYP1	BEGW	0, 0, *	Wait reply
	00	0	00000				
00052	74	3	P00052		BEGW	0, CARG, *	Do a carriage return
	00	0	P00064				
00053	75	0	P00046		SLJ	TYPE	
	50	0	00000				
00054	75	0	P00054	LDAD	SLJ	*	Load address routine
	50	0	00000				
00055	74	1	P00055		EXTF	10B, 40B, *	Wait reply
	10	0	00040				
00056	74	3	P00056		BEGW	10B, LDADC, *	Wait reply
	10	0	P00060				
00057	75	0	P00054		SLJ	LDAD	
	50	0	00000				
00060	10	0	00001	LDADC	IOTW	DRAD, 1	Control word for Drum Address
	00	0	P00067				
00061	10	0	00002	NRTY	IOTW	NRTC, 2	Control word Not Ready typeout
	00	0	P00070				
00062	10	0	00003	WCTOC	IOTW	WCTO, 3	Control word for WRTCK typeout
	00	0	P00072				
00063	10	0	00003	RDECW	IOTW	RDETO, 3	Control word for RD Data Error
	00	0	P00075				
00064	10	0	00001	CARG	IOTW	CRR, 1	Control word for CR return
	00	0	P00100				
00065	10	0	01000	WDATA	IOTW	WRTDA, 1000B	Control word for write data
	00	0	P00101				
00066	10	0	01000	RDATA	IOTW	REDDA, 1000B	Control word for read data
	00	0	P01101				
00067	00	0	00000	DRAD	OCT	0	Drum address in use
	00	0	00000				

00070	63	6	05556	NRTC	TYPE	2,*R DRUM NOT READY	
	35	7	26031				
00071	42	7	56056				
	51	1	25540				
00072	63	6	00256	WCTO	TYPE	3,*R WRITE CHECK ERROR	
	16	7	55160				
00073	11	4	55111				
	15	6	05156				
00074	56	4	25660				
	60	6	06060				
00075	63	6	05651	RDETO	TYPE	3,*R READ DATA ERROR	
	12	5	56055				
00076	12	7	51260				
	51	5	65642				
00077	56	6	06060				
	60	6	06060				
00100	00	0	00000	CRR	OCT	63	Carriage return
	00	0	00063				
00101				WRTDA	BSS	1000B	Write buffer
01101				REDDA	BSS	1000B	Read buffer
							END

SECTION B

363X-A DISK FILE CONTROLLER

CONTENTS

Functional Description	B-3	Positioner Switching Time	B-28
System Organization	B-3	Positioning Time	B-28
Organization of the Disks	B-4	Latency Time	B-28
Control Words	B-6	Manual Operation	B-29
Address Control Word	B-7	Controller Switches and	
Search Code Word	B-8	Indicators	B-29
Data Transfer Operations	B-8	Equipment Number Switch	B-29
Write	B-8	Connect Indicator	B-30
Write Check	B-9	Parity Error Indicator	B-30
Read	B-10	File Unit Designator Switches	B-30
Check Mode (Read)	B-11	Redundant Unit Indicators	B-30
Search Operations	B-11	Controller Maintenance Switches	
Data Search	B-11	and Indicators	B-30
Error Search	B-12	Controller On Switch	B-30
Codes	B-13	Controller Off Switch	B-32
Connect Code	B-14	Controller Error Indicator	B-32
Equipment Number (range 0-7)	B-14	Master Clear Switch	B-32
Unit Number (range 0-3)	B-14	Ready Indicator	B-32
Access	B-14	File Unit Switches	B-32
Disk Number (range 00-17 _g)	B-15	On Line Indicators	B-32
Function Codes	B-16	Over Temp Indicators	B-32
Clear Codes	B-16	Panel Control Switches and	
Mode Select Codes	B-17	Indicators	B-33
Address Codes	B-18	Status Indicators	B-33
Interrupt Codes	B-20	File Unit Switches and Indicators	B-33
Status Codes	B-21	Write Lockout Switches	B-33
Programming Considerations	B-25	File Unit Maintenance Panel	B-34
Loading the Control Words	B-25	Start-Up Procedure	B-34
Basic Programming Steps	B-27	Turn-Off Procedure	B-35
Clearing the Parity Error		Sample Program Routines	B-36
Indications	B-27	3600 Sample Routine	B-36
Access Time	B-28	160-A Sample Routine	B-36

FIGURES

B-1	System Configuration	B-1	B-9	Return Address Word	B-19
B-2	828 Disk File	B-2	B-10	Address Loading Order	B-26
B-3	Simplified Block Diagram, 363X/828 Disk File System	B-3	B-11	Controller Switches and Indicators	B-29
B-4	Set of Disks and Positioner	B-5	B-12	Maintenance Panel Switches and Indicators	B-31
B-5	Zone and Sector Organization	B-6	B-13	Write Lockout Switches	B-33
B-6	Address Control Word	B-7	B-14	Flow Chart: 3600 Disk File Routine	B-37
B-7	Search Code Word	B-8	B-15	Flow Chart: 160-A/3681/ 363X Routine	B-43
B-8	Connect Code	B-14			

TABLES

B-1	System Specifications	B-1	B-3	Starting Checklist	B-35
B-2	Connect, Function, and Status Codes	B-13			

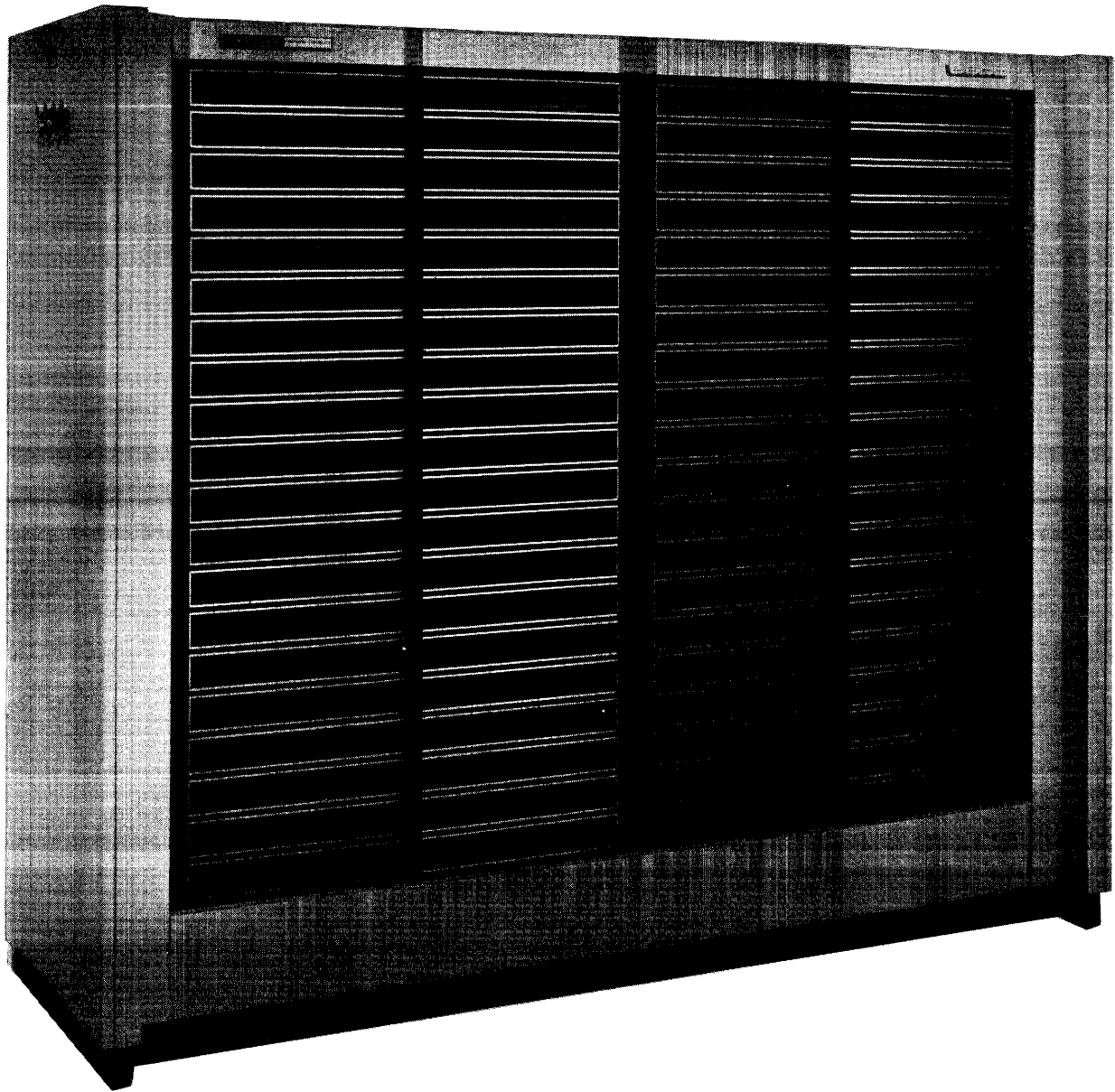

1474

363X MAGNETIC DISK FILE CONTROLLER

SECTION B

363X-A DISK FILE CONTROLLER

The 363X/828 Disk File System is a large scale, random-access, mass storage system. It consists of a CONTROL DATA* 363X-A** Disk File Controller and from one to four CONTROL DATA 828-A Disk File units each storing 16,777,216 12-bit words. A dual access feature allows two data channels to communicate simultaneously with any of the 828 Disk File units. Table B-1 lists the system specifications. Figure B-1 shows the basic system configuration. Figure B-2 shows the 828 Disk File unit.

TABLE B-1. SYSTEM SPECIFICATIONS

CONTROLLER MODEL	NUMBER OF 828 FILE UNITS	STORAGE CAPACITY	TRANSFER RATE	AVERAGE ACCESS TIME
3632	1	16,777,216 12-bit bytes	60,000 12-bit bytes per second (outer disk zone)	242 milliseconds
3633	2	33,554,432 12-bit bytes		
3634	3	50,331,648 12-bit bytes	35,000 12-bit bytes per second (inner disk zone)	
3635	4	67,108,864 12-bit bytes		

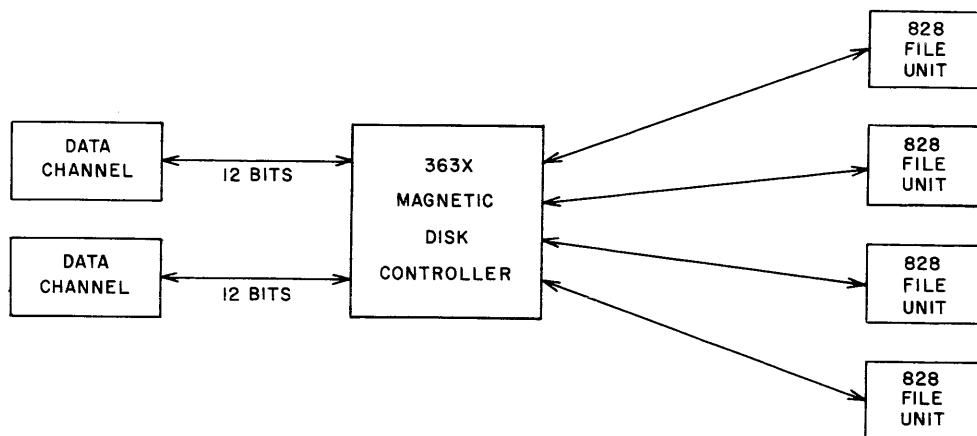

Figure B-1. System Configuration

* Registered trademark of Control Data Corporation

** Includes 3632-A, 3633-A, 3634-A, and 3635-A

Data is recorded on constantly rotating magnetic disks which are organized in individually addressable blocks (termed sectors) of 128 12-bit bytes. The disk system can perform the following operations:

- 1) Read - The operation in which data is transferred from the disk system to the data channel in 12-bit bytes.
- 2) Write - The operation in which a series of 12-bit bytes from the channel is recorded in the disk system.
- 3) Check Mode - A special Read mode in which the disk system sends an automatically generated check word to the data channel at the end of each sector.
- 4) Write Check - A special Write mode in which the disk system automatically verifies the accuracy of data after it is written on a disk.
- 5) Data Search - An operation in which a disk is searched for a group of bytes equal to a search code word stored in the disk controller. No data is transferred during this operation.
- 6) Error Search - A mode of operation in which a disk is searched for a data block which contains a recording error. No data is transferred during this operation.

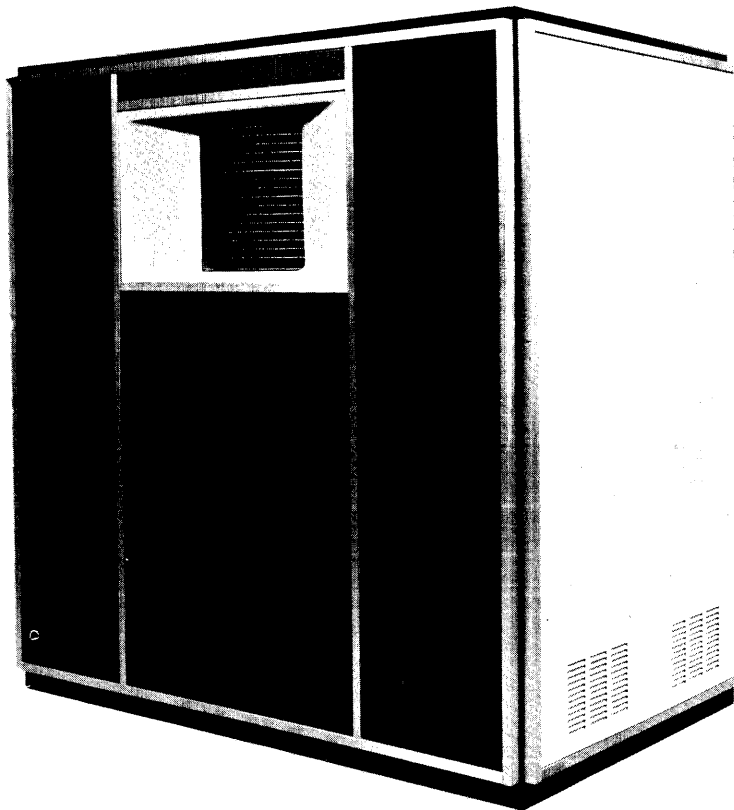

Figure B-2. 828 Disk File

1331

FUNCTIONAL DESCRIPTION

SYSTEM ORGANIZATION

Figure B-3 shows the components in the disk file system. Each 828 Disk File unit contains 16 disks (Figure B-4).

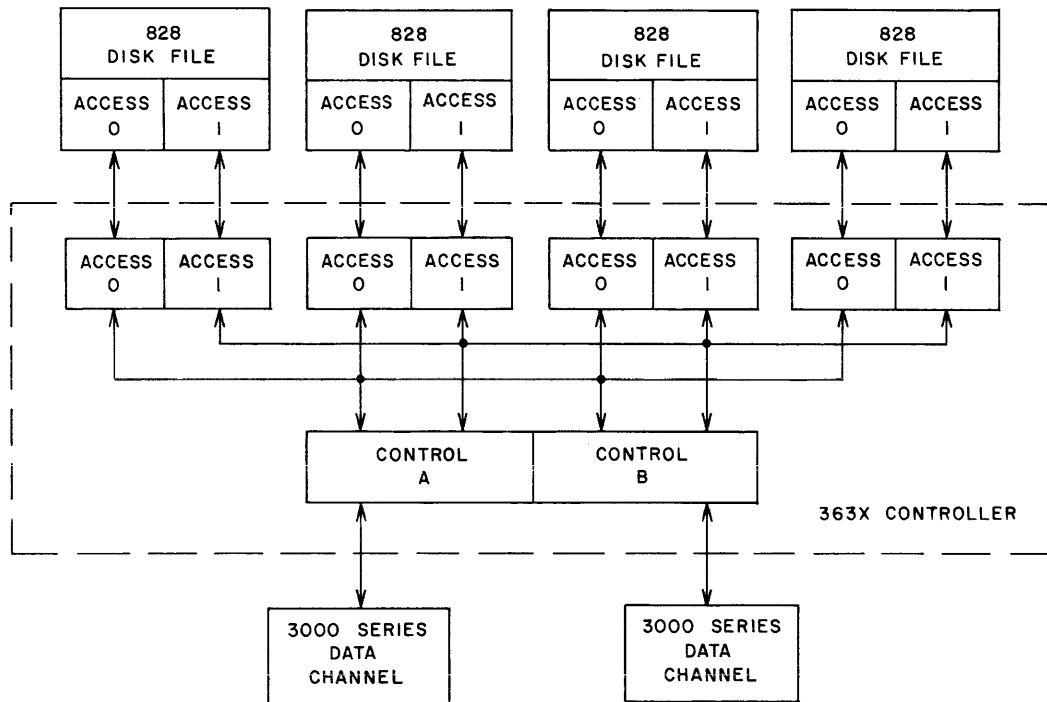

Figure B-3. Simplified Block Diagram - 363X/828 Disk File System

The 363X controller ranks as an equipment in the computer system. The 828 Disk File units, the two accesses within each file unit, and the 16 disks within each file unit are subordinate to the 363X controller. For selection purposes the components in the disk system are assigned identification numbers as follows:

- 1) The two controls in the 363X controller are assigned an equipment number (0-7) by means of two 8-position Equipment Number switches.
- 2) Each 828 file unit is assigned a file unit number (0-3) by means of a File Unit Designator switch.
- 3) The two accesses within a file unit are designated 0 and 1.

- 4) Each of the 16 disks within a file unit are assigned a disk number (0-17₈) as shown in Figure B-4.

Before the disk system can communicate with either data channel the computer must select, via a data channel, 1) the 363X controller, 2) one of the four possible 828 file units, 3) one of two accesses and, 4) one of the 16 disks. A Connect operation performs this selection. Refer to the section on Connect (page B-14) for the specific details of the Connect operation.

The two data channels can each select disks in the same file unit or in different file units. Both data channels cannot simultaneously communicate with the same disk.

ORGANIZATION OF THE DISKS

The 16 disks in a file unit (Figure B-4) rotate at a constant rate on a common shaft. Both sides of the disks are used for data storage. Data is recorded serially in tracks on the disk so that each 12-bit byte appears as 12 sequential bits in a track. The 363X controller converts data bytes from 12-bit parallel form sent by the data channel to serial form required by the disk file.

Each disk is served by its own head positioner as shown in Figure B-4. The 16 head positioners are independent of each other and any one can move without disturbing the others. Although there are eight read/write heads on each positioner, only one can be active at a time. Since there are eight heads, eight tracks can be recorded or read without moving the positioner. The positioner can be moved to any one of 64 locations, thus $8 \times 64 = 512$ tracks can be recorded on the two sides of the disk. Each of the 64 locations is assigned a positioner address in the range 00 through 77₈.

A disk is divided into two zones (Figure B-5). Each zone contains 256 tracks (total for both sides) and each track is divided into sectors. A sector holds 128 12-bit bytes plus a 12-bit check word. There are 12 sectors per track in the inner zone and 20 sectors per track in the outer zone making a total of 8192 sectors on a disk.

In any of the 64 positioner addresses, four of the read/write heads are in the inner zone and four are in the outer zone. Thus, a total of 128 ($4 \times 12 + 4 \times 20$) sectors can be written or read without moving the head positioner. For addressing purposes the 128 sectors within each positioner address are each assigned a sector address in the range 000-177₈.

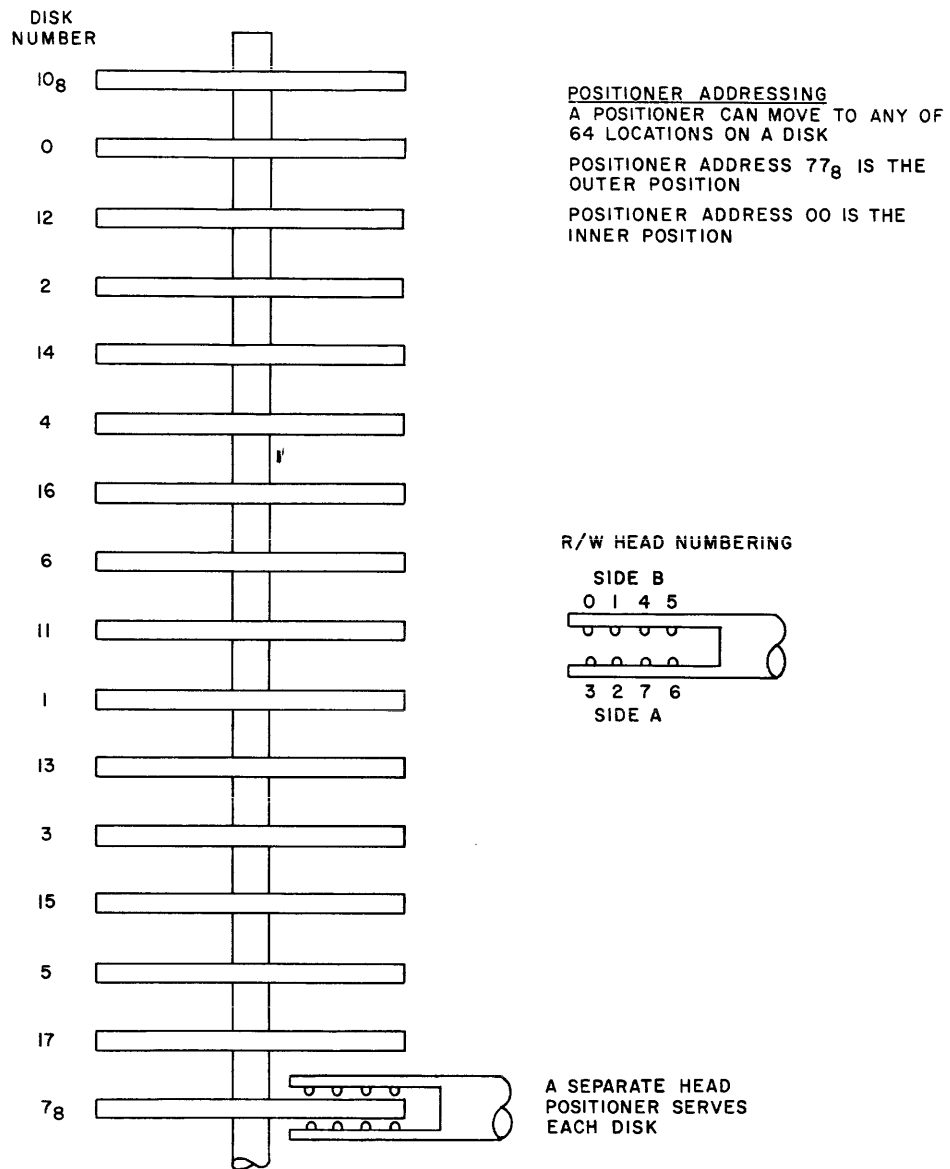
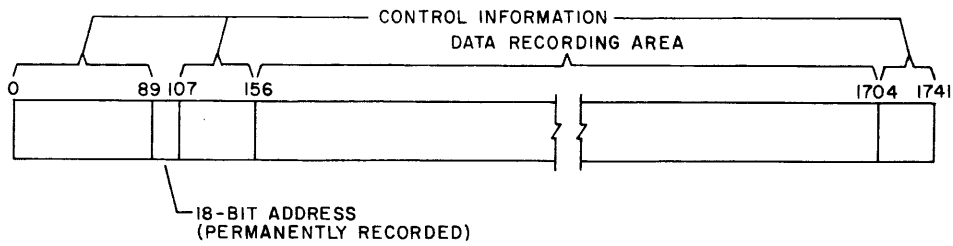

Figure B-4. Set Of Disks And Positioner

A positioner address together with a sector address uniquely designates one of the 8192 sectors on a disk.

Figure B-5 shows the format of a sector. The data recording area is the only portion of the sector that the programmer can access. All other information is automatically written by the disk system.



SECTOR ORGANIZATION

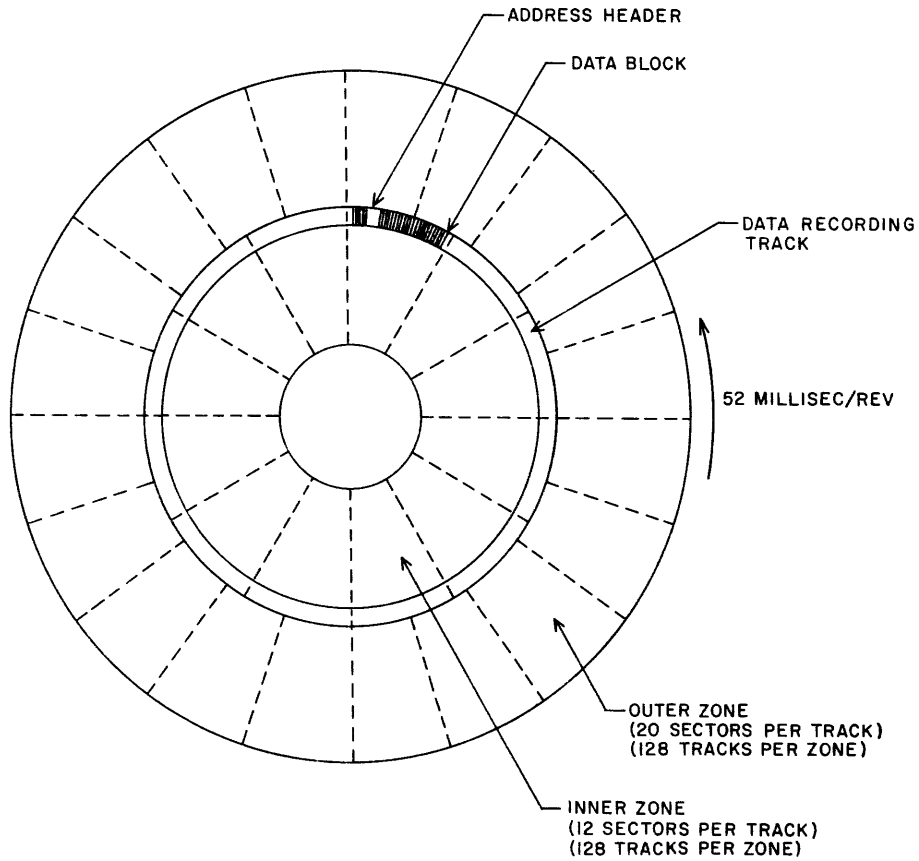

Figure B-5. Zone and Sector Organization

CONTROL WORDS

Two control words, the address control word and the search code word, govern Read, Write, and Search operations. These control words are transmitted from the computer by a computer output operation and stored in registers in the controller. Two pairs of control words, one set for each control, are stored in the controller so that two simultaneous operations can be governed.

Address Control Word

Figure B-6 shows the format of the address control word.

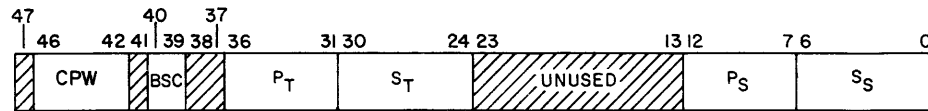

CPW = Compare Word (00-37)* } Used for Data Search operation
 BSC = Byte Search Code** } only
 P_t = Terminating Positioner Address (0-77) } Used for Data Search
 S_t = Terminating Sector Address (0-177) } or Error Search
 P_s = Starting Positioner Address (0-77) } operations only.
 S_s = Starting Sector Address (0-177)

* Selects one of 32 48-bit words in a sector for comparison with the search code word held in the controller.

** 00 = Search for a compare of byte 4 only.
 01 = Search for a compare of bytes 4 and 3 only.
 10₂ = Search for a compare of bytes 4, 3, and 2 only.
 11₂ = Search for a compare of bytes 4, 3, 2, and 1.

Figure B-6. Address Control Word

Bits 0-12 contain the positioner address (P_S) and sector address (S_S) at which a Read, Write, or Search operation is to begin. Bits 24-46 are of significance only for a Data Search operation.

Bits 24-36: These bits specify the positioner address (P_t) and sector address (S_t) at which a Data Search or Error Search operation stops.

Bits 39, 40: These bits specify which of the four bytes in the 48-bit search code word (Figure B-7) are to be used for comparison in a Data Search operation.

Bits 42-46: These bits designate which one of the thirty-two 48-bit data words in each sector is to be compared for equality against the search code word.

During a Read, Write, or Search operation, the starting sector address (S_S) and starting positioner address (P_S) are advanced as the operation proceeds from sector to sector and position to position. The upper portion of the control word (bits 24-46) remains fixed until a new control word is loaded.

Search Code Word

The search code word (Figure B-7) is the quantity used for equality comparison in a Data Search operation. This operation inspects a disk for a byte or group of bytes equal to the search code word. One, two, three, or four of the bytes can be used for comparison. Bits 39 and 40 of the address control word designate which bytes in the search code word are used.

Once loaded, the search code word remains unaltered until a new code word is loaded.

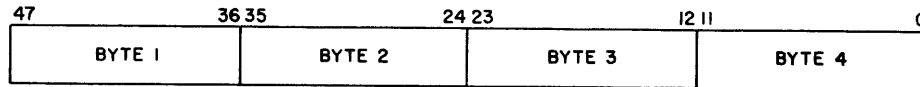

Figure B-7. Search Code Word

The procedure for loading the control words is given later on in this section.

DATA TRANSFER OPERATIONS

Write

During this operation a series of 12-bit bytes are recorded on the selected disk in response to a computer output operation. The computer must first issue the Write Data function code (0041) to prepare the disk system for a Write operation. Data recording begins at the starting positioner and sector address (P_s , S_s) contained in the address control word and continues until the computer terminates the output operation. If less than one sector (128 bytes) is transferred, the disk system automatically fills the remainder of the sector with "0's".

If a long block of data is written, the operation advances sequentially from sector to sector and track to track. When the last of the eight tracks at a positioner address has been filled, the head positioner automatically moves to the next sequential positioner address. During the positioning period (157 ms) the data channel temporarily stops transmitting data.

During a Write operation the disk system checks each 12-bit byte for parity. If a parity error occurs, the disk system sends a Parity Error signal to the data channel. A PARITY ERROR indicator on the 363X controller also lights. A parity error does not cause the Write operation to stop.

If the computer does not terminate the output operation when the last sector on the disk is filled, the positioner moves to positioner address 00. Recording continues in sector 00 of this position.

Throughout the Write operation, the starting sector and position addresses in the address control word are incremented as the operation progresses. When the computer terminates the operation, the address control word contains the address of the next sector.

During a Write operation a 12-bit checkword is automatically generated and written at the end of each sector as the 129th byte. The checkword is later used to verify the accuracy of data read from the disk.

Write Check

This mode (0043) is identical to the normal Write mode except that the disk system automatically verifies the accuracy of data written in each sector. After each sector is recorded, the data channel temporarily stops transmitting data. One revolution later (52 milliseconds), when the sector last recorded appears under the read/write head, the controller reads the sector from the disk and forms a new checkword. This checkword is compared with the checkword formed when the sector was recorded. If the two checkwords are not identical, a data recording error probably occurred and the sector should be re-written. This condition is indicated by a Checkword Error status bit (bit 10) and also causes the Interrupt on Abnormal End of Operation (if this interrupt has been selected).

After the check-read cycle, data recording immediately resumes in the next sector if the data channel has not terminated the output operation.

After data has been written the data channel may disconnect. The disk system will complete the check portion of the operation independent of the data channel. This frees the data channel for another task during the 52 millisecond check cycle. If Interrupt on End of Operation is selected, the disk system sends an interrupt when the check cycle is complete.

Since the check cycle requires 52 milliseconds it can be used most efficiently for single-sector transfers. Multiple-sector transfers should be performed using a normal Write operation followed by an Error Search operation.

Read

During this operation sequential 12-bit bytes from the selected disk are transferred to the data channel in response to a computer input operation. The computer must first issue the Read Data function code (0040) to prepare the controller for a Read operation. The operation starts at the beginning of the sector designated by the starting positioner and sector address (P_s , S_s) in the address control word. The Read operation progresses sequentially from sector to sector and track to track, as in a Write operation, until the data channel terminates the operation. The data channel terminates a Read operation in two ways:

- 1) When the number of words specified in the computer input instruction have been transferred.
- 2) On End of Record. The disk system sends an End of Record signal to the data channel at the end of each sector during a multiple-sector Read operation. This signal causes the data channel to terminate the input operation if it (the data channel) is programmed to recognize the End of Record signal*. An End of Record is not sent if the input operation is less than or equal to the number of 12-bit bytes in a sector (128).

As each sector is read, a checkword is formed and compared with the checkword written in the sector when the data was recorded. If the two checkwords are not identical, an error probably occurred in the Read operation. This condition is indicated by the Checkword Error status bit (bit 10). It also causes the Interrupt on Abnormal End of Operation if this interrupt has been selected.

As the Read operation progresses, the starting positioner and sector addresses in the address control word are incremented.

If function code 0060 (Read Data with End of Record Disabled) is issued instead of code 0040, the disk system performs a Read operation as described but does not send an End of Record signal at the end of each sector.

During a Read operation the disk system adds a redundant parity bit to each 12-bit byte sent to the data channel. The data channel checks each byte for correct parity. If a parity error occurs, an I/O parity error bit in the data channel sets. The Read operation does not stop however.

* In 3100 and 3200 systems a Read operation always terminates on End of Record.

Check Mode (Read)

This mode (selected by function code 0042) is identical to the standard Read mode except that the checkword is sent to the data channel as the 129th byte in each sector. The disk system sends an End of Record signal after the checkword in multiple-sector transfers.

Note that there are an uneven number of bytes (129) in each sector when this mode is used. Thus in a multiple-sector Read (Check Mode) operation, corresponding bytes in successive sectors will not occupy corresponding positions in storage words. For example, in a computer system with a 48-bit storage word (3400, 3600, 3800), the checkword for the first sector will be entered into the upper 12 bits of the 33rd storage word. The first byte in the second sector follows in bits 24-35 of the 33rd storage word and the checkword for the second sector (129th byte) will occupy bits 24-35 of the 65th storage word.

If only a single sector is read, the checkword is stored in the upper 12 bits of the 33rd storage word and the remainder of this storage word is automatically filled with "0's".

If function code 0062 (Check Mode with End of Record Disabled) is issued instead of 0042, the disk system performs the Check Mode (Read) operation but does not send an End of Record signal at the end of each sector.

During a Check Mode operation the data channel checks for parity errors as in a normal Read operation.

SEARCH OPERATIONS

There are two Search operations: Data Search and Error Search. No data is exchanged between the disk system and data channel during these operations.

Data Search

This operation, initiated by function code 0044, compares a specified 48-bit portion of each sector with the 48-bit search code word (Figure B-7). The Data Search is satisfied when a word equal to the search code word is found.

The search begins at the starting sector and positioner address (P_s , S_s) contained in the address control word (Figure B-6). It continues until the search is satisfied or the terminating sector (P_t , S_t in the address control word) has been searched.

For Search purposes each sector is considered to contain 32 48-bit words numbered from 00-37₈. The CPW portion of the address control word (Figure B-6) specifies the word in each sector that is compared with the search code word.

One, 2, 3, or 4 of the bytes in the search code word can be used for comparison. Bits 39 and 40 of the address control word designate the bytes in the search code word to be compared with the corresponding bytes in the specified sector word. The four combinations of bytes are:

<u>Bits 39, 40</u>	<u>Combination</u>
00	Compare byte 4 (bits 36-47)
01	Compare bytes 3 and 4 (bits 24-47)
10 ₂	Compare bytes 2, 3, and 4 (bits 12-47)
11 ₂	Compare bytes 1, 2, 3, and 4 (bits 0-47)

If the search is satisfied, the Search Satisfied status bit (bit 6) is set.

The data channel need not remain connected to the disk after the Search operation is initiated. The disk system sends an interrupt signal to the computer when the Search operation terminates if Interrupt on End of Operation has been selected.

As in Read and Write operations, the starting sector and positioner addresses (P_s , S_s) in the address control word are incremented as the operation progresses.

The return address word (explained later in this section) can be read in by the computer to determine the sector in which the Search terminated.

Error Search

This operation, initiated by function code 0046, searches the disk for a checkword error. The controller reads data from the disk and forms a checkword for each sector. This new checkword is compared with the checkword formed when the sector was written. A checkword error exists if the two checkwords are not identical.

The operation begins at the starting sector and track addresses (P_s , S_s) specified in the address control word. It terminates when a checkword error is found or when the terminating sector (P_t , S_t in the address control word) has been searched.

If a checkword error is found, the Checkword Error status bit (bit 10) is set.

The data channel can disconnect from the disk after the Search has been initiated. The disk system sends an interrupt signal when the Search operation terminates if Interrupt on End of Operation has been selected. If interrupt is desired only when a checkword error is found, Interrupt on Abnormal End of Operation can be used.

The starting address (P_s , S_s) in the address control word is incremented throughout the Error Search operation as in the other operations.

The computer can read in the return address word to determine the sector in which the Error Search operation stopped.

CODES

Table B-2 lists the codes that control the disk system. The section following Table B-2 describes each code in detail.

TABLE B-2. CONNECT, FUNCTION, AND STATUS CODES

CONNECT	
Connect Disk	Nuua00dddd*
FUNCTION	
Release and Disconnect	0000
Clear	0007
Select Interrupt on Ready and Not Busy	0020
Release Interrupt on Ready and Not Busy	0021
Select Interrupt on End of Operation	0022
Release Interrupt on End of Operation	0023
Select Interrupt on Abnormal End of Operation	0024
Release Interrupt on Abnormal End of Operation	0025
Read Data	0040
Write Data	0041
Check Mode (Read)	0042
Write Check	0043
Data Search	0044
Error Search	0046
Return Address	0050
Load Address	0051
Read Data with End of Record Disabled	0060
Check Mode with End of Record Disabled	0062

*N₈ = equipment number of controller (3 bits), uu₂ = unit number (2 bits), a₂ = access number (1 bit), and dddd₂ = disk number (4 bits).

TABLE B-2. CONNECT, FUNCTION, AND STATUS CODES (Cont'd)

STATUS	
Ready	XXX1
Busy	XXX2
Access Unavailable	XXX4
On Track	XX1X
Write Permit	XX2X
Lost Data	XX4X
Search Satisfied	X1XX
Interrupt on Ready and Not Busy	X2XX
Interrupt on End of Operation	X4XX
Interrupt on Abnormal End of Operation	1XXX
Checkword Error	2XXX
Reserved (by other channel)	4XXX

CONNECT CODE

The computer must issue a Connect code (via a data channel) to select the disk system before it will respond to a function code or data transfer operation. The Connect code (Figure B-8) is the lower 12 bits of the computer Connect instruction.

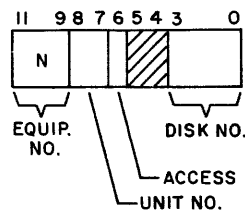

Figure B-8. Connect Code

Equipment Number (range 0-7)

This code selects the disk control from among several equipments attached to the data channel. These bits must match the setting of the 8-position Equipment Number switch on the control. There are two of these switches, one for each control.

Unit Number (range 0-3)

This code selects one of the four possible file units. It must match the setting of the 4-position File Unit Designator switch on the desired file unit.

Access

This code designates Access 0 or Access 1 in the selected file unit.

Disk Number (range 00-17₈)

This code specifies one of 16 disks within the selected file unit.

Normally the disk system returns a Reply to the data channel in response to a Connect code. The Reply enables the computer to proceed with the next instruction.

Under some conditions the disk system cannot Connect. In these cases the disk system returns a Reject signal which causes the computer to jump to the Reject address contained in the Connect instruction.

After a Connect operation, the disk system remains connected until the data channel, 1) connects another device, 2) issues function code 0000 (Release and Disconnect), or 3) issues a Master Clear or Channel Clear.

A Connect operation also reserves the access and disk specified in the Connect code for the data channel issuing the code. This reservation remains in effect when the data channel disconnects the disk system by connecting another device. If a data channel attempts to connect an access or disk reserved by the other channel, the Connect code will be rejected. A reservation is cleared by function code 0007 (Release and Disconnect), a Master Clear, or Channel Clear instruction.

In some operations (Search or check portion of Write Check) data is not transferred and the data channel need not remain connected throughout the operation. If the program disconnects the data channel in these cases and then attempts to re-connect before the operation is complete, the Connect code will be rejected unless it is identical to the original Connect code.

The disk system also rejects a Connect code if the specified file unit is Not Ready.

The disk system checks each Connect code sent from the data channel for a transmission parity error. If a parity error occurs, the disk system does not connect and returns neither a Reply nor Reject. A PARITY ERROR indicator on the 363X controller lights. The disk system does not return a Parity Error signal to the data channel in this case. A Master Clear or Clear Channel instruction will clear the PARITY ERROR indicator.

FUNCTION CODES

Function codes establish operating modes and Select or Release conditions with the disk system. The computer issues a function code by executing a function instruction which contains the 12-bit function code.

If the disk system can comply with a function code, it returns a Reply to the data channel. The computer then proceeds with the next instruction in the program. If the disk system cannot accept the function code it returns a Reject that causes the computer to jump to the Reject address contained in the computer function instructions.

The computer will reject function codes in the following cases.

- 1) Codes not applicable to the disk system (codes not listed in Table B-2 are rejected).*
- 2) All function codes are rejected when the disk system is Busy, i. e., when engaged in a data transfer or Search operation or when the head positioner for the selected disk is in motion.

If a parity error occurs in a function code, the disk system does not accept the code and returns neither a Reply nor Reject. Instead it sends a Parity Error signal to the data channel. A PARITY ERROR indicator on the disk system controller also lights.

There are four categories of function codes: 1) Clear codes, 2) Mode Select codes, 3) Address codes, and 4) Interrupt Select codes.

Clear Codes

Release and Disconnect (0000)

This code releases the connected file unit and clears the reservation for this unit. It also deactivates the disk positioner within that file unit. The use of this code before connecting another disk in the same file unit reduces disk switching time by 10 ms (to approximately 13 ms).

*Exception: Codes 0045, 0047, and 0052-0057, though not applicable, are not rejected. The disk system returns a Reply but otherwise ignores these codes.

Clear (0007)

This code releases the connected file unit and clears the reservation for this unit. Unlike code 0000 it does inactivate the connected disk positioner.

Mode Select Codes

These codes select the six operating modes. Once a mode is selected, it remains in effect until a new Mode Select code is issued or until a Channel Clear instruction or Master Clear is executed.

Read Data (0040)

This code prepares the disk system for an input (Read) operation. Refer to the Functional Description for a detailed explanation of a Read operation.

Read Data with End of Record Disabled (0060)

This code is identical to code 0040 except that the disk system does not send an End of Record signal at the end of each sector during a Read operation.

Write Data (0041)

This code conditions the disk system for a Write operation. A detailed explanation of this operation is included under Functional Description.

Check Mode (0042)

This code prepares the disk system for a special type of Read operation in which a check word is sent to the data channel as the 129th byte in each sector. See the Functional Description for a full explanation of this operation.

Check Mode with End of Record Disabled (0062)

This code is identical to code 0042 except that the disk system does not send an End of Record signal at the end of each sector.

Write Check (0043)

This code prepares the disk system for a special Write operation in which the accuracy of data written on the disk is automatically verified by the disk system. The Write Check operation is fully described under the Functional Description.

Data Search (0044)

Code 0044 initiates a Data Search operation. In this operation the selected disk is scanned for a 48-bit word that is equal to a search code word held in the controller. See the Functional Description for a complete explanation of this operation.

Error Search (0046)

This code initiates an Error Search operation in which the selected disk is scanned for a sector that contains a checkword error. The operation is described in detail in the Functional Description.

Address Codes

These codes provide a means of loading the address control word and search code word and a method of checking the address at which an operation terminated.

Return Address (0050)

This code makes the return address word (Figure B-9) available for input to computer. A 4-byte input (Read) operation should follow to read in the word.

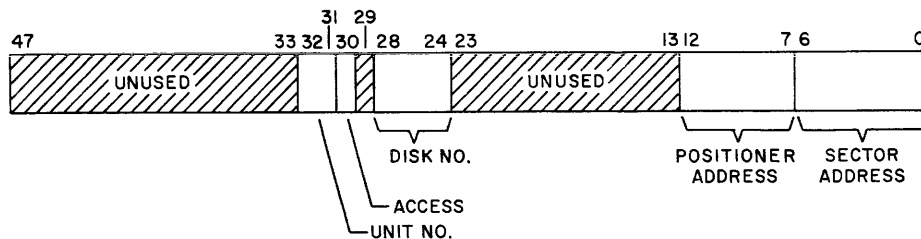

Figure B-9. Return Address Word

- Bits 0-6 These bits contain the last sector address plus 1 for all operations except Data Search and Error Search. After a Data Search or Error Search bits 0-6 contain the address of the last sector searched.
- Bits 7-12 These bits contain the last positioner address.
- Bits 24-32 These bits indicate the file unit, access, and disk currently connected.

This code is rejected if the head positioner is seeking a new position or is not in the position specified in the address control word due to a malfunction.

Load Address (0051)

This code prepares the disk system for the loading of the address control word (Figure B-6) and the search code word (Figure B-7). After this code is received, the disk system loads the next 8 data bytes from the data channel into the appropriate address registers. The first 4 bytes comprise the address control word and the next 4 bytes form the search code word. See Programming Considerations for a full explanation of the address loading process.

Since the disk system can conduct simultaneous operations with both data channels, it holds one set of control words in Control A and another set in Control B.

Interrupt Codes

The interrupt feature allows the disk system to notify the computer when it is available for operation or has completed an operation.

There are three interrupts which can be selected or released by function codes:

- Interrupt on Ready and Not Busy
- Interrupt on End of Operation
- Interrupt on Abnormal End of Operation

If one of these interrupts is selected and an associated interrupt condition occurs (for example, an Abnormal End of Operation), the disk system sends an Interrupt signal to the central processor via the data channel. The Interrupt signal usually causes the computer to jump to an interrupt routine that processes the interrupt condition.

Status bits are associated with each of the interrupt conditions so that the cause of an interrupt can be determined by a status request.

The Interrupt signal remains up until cleared. It is cleared by, 1) any of the six interrupt function codes, 2) a Clear Channel instruction or manual Master Clear, or 3) initiation of a new input or output operation.

The Interrupt signal is transmitted to a data channel on one of eight interrupt lines. The line used corresponds to the Equipment Number switch on the controller. For example, if the switch is set at 5, the Interrupt signal is sent on line 5. Since each equipment attached to a data channel has a unique Equipment Number, each uses a different interrupt line. The computer can inspect the interrupt lines to identify which of the eight possible equipments on a data channel has sent an interrupt.

Select Interrupt on Ready and Not Busy (0020)

When this code is in effect, the disk system sends an Interrupt signal whenever it becomes Ready and Not Busy.

- Not Busy - The system is Not Busy when it is not engaged in any computer initiated operation.
- Ready - The system is Ready when no conditions exist that prevent operation under program control. See Ready Status Code (page B-22) for a list of the Ready conditions.

Release Interrupt on Ready and Not Busy (0021)

This code releases the interrupt selection established by code 0020.

Select Interrupt on End of Operation (0022)

When this code is in effect the disk system sends an Interrupt signal whenever a Read, Write, or Search operation terminates either normally or because of some abnormal (error) condition.

Release Interrupt on End of Operation (0023)

This code releases the interrupt selection established by code 0023.

Select Interrupt on Abnormal End of Operation (0024)

When this code is in effect the disk system sends an Interrupt signal if, 1) a checkword error occurs, 2) a Lost Data condition occurs, or 3) the system becomes Not Ready.

See Status Codes (pages B-23 and B-22) for an explanation of the Lost Data and Not Ready conditions.

Release Interrupt on Abnormal End of Operation (0025)

This code releases the interrupt selection established by code 0024.

STATUS CODES

Two 12-bit status words, one for each control, indicate various conditions in the disk system to the computer. Each bit in a status word indicates the presence or absence of a condition such as Busy or Ready. A status word is available for sensing by the computer whenever the disk system is connected. It is also available after the disk system has rejected a Connect code so that the reason for the Reject can be determined. A status word indicates conditions in the control, file unit, access, and disk currently connected.

Ready (XXX1)

Bit 0 is set when the disk system is ready to operate under computer control. This means that:

- 1) The disks are rotating at the proper rate.
- 2) The read/write heads are extended to a position just above the disk surface.
- 3) All test switches are in the OFF position.
- 4) The positioner for the connected disk is positioned over the track which corresponds to the sector address in the address control word.
- 5) None of the error conditions listed below exist.

The disk becomes Not Ready if conditions 1-3 above fail to hold or if:

- 1) A Write Monitor error occurs.
- 2) A Sector Error occurs.
- 3) The Write Lockout error occurs.
- 4) A File Warning exists in the connected file unit.

Busy (XXX2)

Bit 1 is set when a Read, Write, Return Address, Load Address, Write Check, or a Search operation is in progress. It is also set when the head positioner is seeking a new positioner address. The disk system will reject any function code or a Read (input) or Write (output) instruction when it is Busy.

Access Unavailable (XXX4)

Bit 2 is set when the access specified in a Connect code is in use or reserved by the other read/write control. This bit clears when the access is released.

On Track (XXIX)

Bit 3 is set when the positioner, and hence, the read/write heads are correctly positioned according to the positioner address in the address control word. The bit is a "0" if the positioner moves off the track for any reason (i. e., the repositioning of the heads or a mechanical error).

Write Permit (XX2X)

Bit 4 is set whenever it is permissible to both write on or read from the connected disk. The bit remains a "1" unless the Write Lockout switch for the connected disk is placed in the ON position. If this bit is "0", only a Read operation can be performed.

NOTE

This bit does not become significant until a Mode Select function code is sent to the disk. If a Write Lockout condition exists, the bit will go to "0".

Lost Data (XX4X)

Bit 5 is set when the data channel fails to transfer data at the rate required by the disk. This rate is 35,710 bytes per second for the inner zone and 58,820 bytes per second for the outer zone. This condition can occur when the data channel must compete with other devices for access to core storage.

When the disk system is controlled by a CONTROL DATA 160 or 160-A Computer via a CONTROL DATA 3681 Data Channel Converter, Lost Data is also set if the Read or Write selection in the 3681 converter is not cleared immediately after a Read or Write operation is completed.

The bit is cleared by a Connect code, a Mode Select function code, or a Master Clear.

Search Satisfied (X1XX)

Bit 6 is set when a Data Search (0040) operation is satisfied (i. e., a data word identical to the search code word is found). It is cleared by a Connect code, a Mode Select function code, a Master Clear, or Clear Channel instruction.

Interrupt on Ready and Not Busy (X2XX)

Bit 7 is set when the disk system becomes Ready and Not Busy if the Ready and Not Busy interrupt has been selected. This bit is not set if the system is Ready and Not Busy when

the interrupt is selected. Bit 7 is cleared by, 1) any Interrupt function code, 2) initiation of a new input or output operation, or 3) a Master Clear.* These actions also clear the Interrupt signal sent to the data channel.

Interrupt on End of Operation (X4XX)**

Bit 8 is set when a normal or abnormal end of operation occurs if the End of Operation interrupt has been selected. This bit is cleared by, 1) any Interrupt function code, 2) initiation of a new input or output operation, or 3) a Master Clear.* These actions also clear the Interrupt signal sent to the data channel.

Interrupt on Abnormal End of Operation (1XXX)**

This bit is set when an abnormal end of operation occurs if the Abnormal End of Operation interrupt has been selected. This bit is cleared by, 1) any Interrupt function code, 2) initiation of a new input or output operation, or 3) a Master Clear.* The Interrupt signal is also cleared by these actions.

Checksum Error (2XXX)

Bit 10 is set when a Checksum Error is detected during a Read Data (0040), Check Mode (0042), Write Check (0043), or Error Search (0046) operation. It is cleared by a Connect code, a Mode Select function code, a Master Clear, or Clear Channel instruction.

Reserved (by other channel) (4XXX)

Bit 11 is set when the data channel attempts to connect to a disk reserved by the other channel. It is cleared when the data channel connects another disk by a Master Clear or Clear Channel instruction.

*Clearing one of the interrupt status bits also clears the other two. Therefore the program should examine all three interrupt status bits before clearing the bits.

**For an explanation of normal and abnormal end of operations, see descriptions of function codes 0022 and 0024.

PROGRAMMING CONSIDERATIONS

LOADING THE CONTROL WORDS

Function code 0051 (Load Address) prepares the disk system to load the two 48-bit control words. A computer output operation must follow to transmit the control words. A total of eight 12-bit bytes is required to load both control words. The first 4 bytes comprise the address control word and the next 4 bytes form the search code word.

It is not necessary to load 8 bytes unless they are all needed. For example, in data transfer operations only the lower 13 bits of the address control word (starting sector and positioner addresses) are used and the search code word is not used at all. In this case only 2 bytes need be loaded. The upper portion of the address control word and the search code word stored in the controller remain undisturbed unless additional bytes are sent.

Function code 0051 (Load Address) clears the starting sector and positioner address portion of the control word registers so that at least 2 bytes must always be loaded. The remaining portions of the control word registers are cleared only as new address bytes are received.

The address loading operation terminates and the Load Address mode clears when 8 bytes have been received or when the computer terminates the output operation if less than 8 bytes are sent.

Figure B-10 shows the order in which storage words are loaded into the address registers in the disk controller. Note that the controller loads the search code word bytes opposite to the order that they appear in storage.

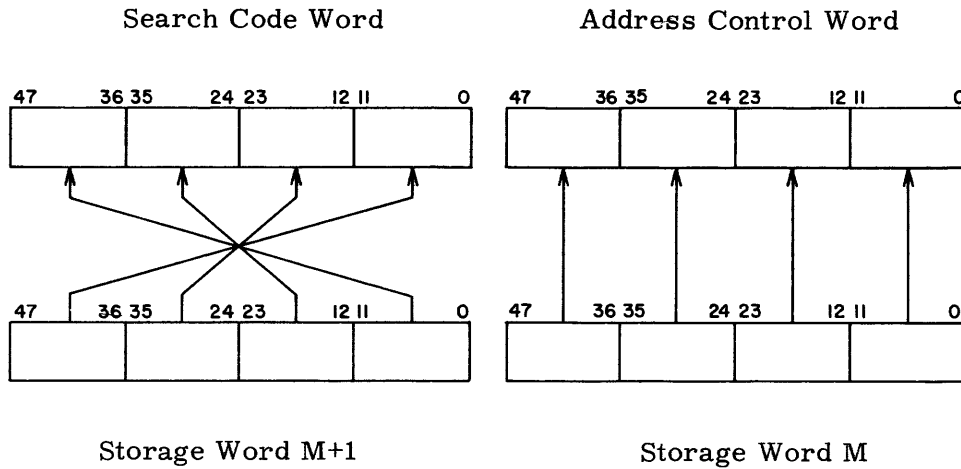

Loading Order - 3400, 3600, 3800

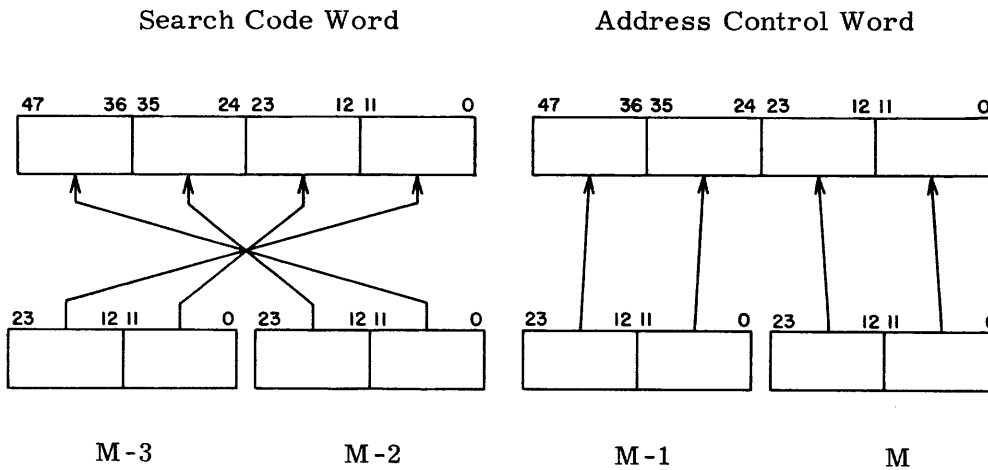

Storage Words

Loading Order - 3100, 3200, 3300 (Reverse Output)

Figure B-10. Address Loading Order

During address loading, the data channel must transmit the output bytes in reverse order, i. e., the least significant byte (bits 0-12) first and the highest order byte last. In 3100, 3200, and 3300 systems the control words must be transmitted by a Reverse Output instruction. In 3400, 3600, and 3800 systems the programmer need not concern himself with the reverse output requirement because the data channel automatically disassembles in reverse when the disk system is in Load Address mode.

A Master Clear or Clear Channel instruction clears the control words.

BASIC PROGRAMMING STEPS

- 1) Select File Connect code selects disk system, file unit, access, and disk. If the specified access or disk is in use or reserved by the other channel or, if the file unit is Not Ready, the disk system rejects the Connect code. The disk system status word can be checked to determine the reason for the reject.
- 2) Select Interrupts Issue function code(s) to select the desired interrupt conditions in the disk system.
- 3) Load Address Issue function code 0051 (Load Address) followed by a computer output operation of 4 bytes containing the address control word. If the search code word is also being loaded, 4 additional bytes are required.
- 4) Select Operating Mode Issue function code to select operating mode or initiate a Search operation.
- 5) Initiate Data Transfer If selected operation is Read or Write, initiate a computer input or output operation.
- 6) Wait For Interrupt If Interrupt on End of Operation has been selected, the disk system sends an Interrupt signal when the Data Transfer or Search operation terminates.
- 7) Check Status Request disk system status word to determine reason for interrupt. The status word also indicates if a Data Search has been satisfied.
- 8) Return Address The return address word can be requested to determine the sector in which the last operation terminated. Issue function code 0050 (Return Address) followed by a 4-byte input operation.

CLEARING THE PARITY ERROR INDICATIONS

If a parity error occurs in a function code or output data sent from the data channel, the disk system brings up a Parity Error signal to the data channel. A PARITY ERROR indicator on the 363X controller also lights. A Master Clear or Clear Channel instruction clears both of these parity error indications.

ACCESS TIME

Access time is:

- 1) The interval between the time a Connect code is issued to select a file unit and disk and the time the disk system is ready to transfer data or begin a Search operation, or
- 2) The interval between the time a new address control word is loaded and the time the disk system is ready to transfer data or begin a Search operation.

Access time includes positioner switching time, positioning time, and latency time.

Positioner Switching Time

This time is the interval required to inactivate the previously selected head positioner and to activate the positioner for the new disk specified in the Connect instruction. This time does not exceed 23 milliseconds. It can be reduced by approximately 10 ms if a Master Clear or Release and Disconnect function code (0000) is issued before the Connect instruction.

Positioning Time

Positioning time is the interval required for a positioner to reach the track that contains the sector specified in the address control word. Positioner motion is initiated when a disk positioner is activated by a Connect operation or when a new address control word is loaded. The positioning time depends on the distance that the positioner must travel.

- Maximum 314 milliseconds
- Average (over all positions) 219 milliseconds
- Average (to adjacent track) 129 milliseconds

Latency Time

Latency time is the interval between the end of positioning time and the time that the addressed sector arrives under the read/write head. Data transfer begins at this point. The maximum latency time is one disk revolution (52 milliseconds). One-half revolution (26 milliseconds) is the average latency time.

During the positioner switching time and the positioning time, the disk system cannot transfer data or begin a Search operation. The disk system will reject Mode Select function codes during these times.

The on track status bit (bit 3) indicates when the positioner has reached the specified track.

MANUAL OPERATIONS

There are four sets of switches and/or indicators associated with the 363X system. Controller switches and indicators are located on the front of the controller chassis. The controller maintenance panel is located on the end of the controller chassis. The file unit maintenance panel is located on one side of the 828 disk file unit and the Write Lockout switchbox is located on the opposite side.

CONTROLLER SWITCHES AND INDICATORS

Equipment Number Switch

An 8-position Equipment Number switch (Figure B-11) is associated with each of the two controls. The setting of this switch (0-7) designates the control and corresponds to the N portion of the Connect code. It also determines the number of the interrupt transmission line that the equipment uses.

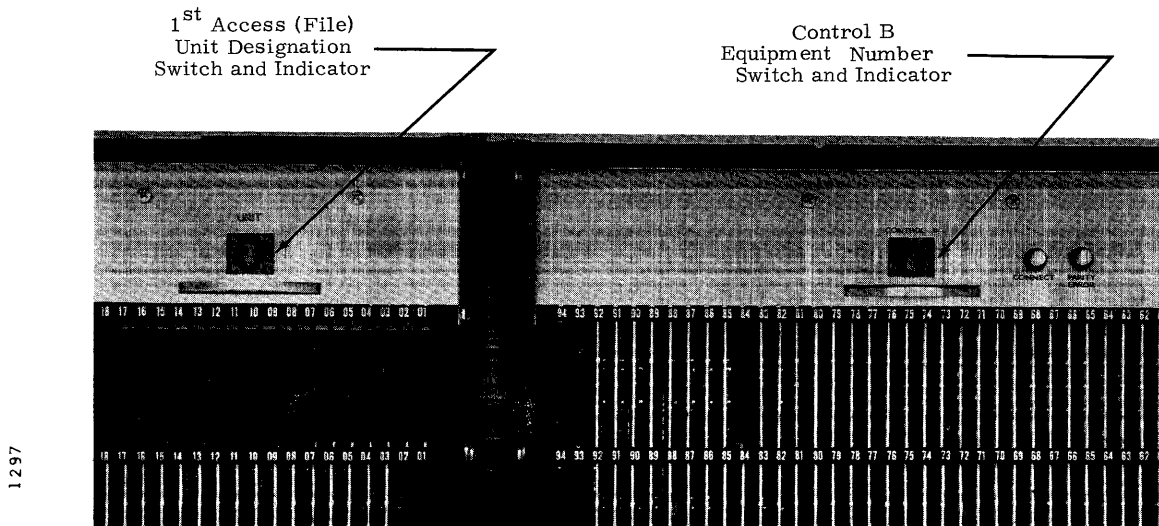

Figure B-11. Controller Switches and Indicators

Connect Indicator

The CONNECT indicator associated with each control is lighted when the control is connected to its associated data channel.

Parity Error Indicator

The PARITY ERROR indicator associated with a control is lighted when the control detects a parity error in a Connect code, a function code, or output data.

File Unit Designator Switches

The file unit switches assign a unique select number (used in the Connect code) to each file unit in the disk system. There is a separate switch on the controller for each file unit. The switches can be set to any number 0-3 (settings 4-7 are not recognized). If two File Unit Designator switches have the same setting, the disk system becomes Not Ready when the computer attempts to connect one of the redundant units.

Redundant Unit Indicators

White indicators in the File Unit Designator switches light when two of the switches have the same setting.

CONTROLLER MAINTENANCE SWITCHES AND INDICATORS

The maintenance panel switches and indicators are shown in Figure B-12.

Controller ON Switch

This switch applies power to the disk system. The file unit toggle switches which control power to the file units should be off when the controller ON switch is pressed.

1337

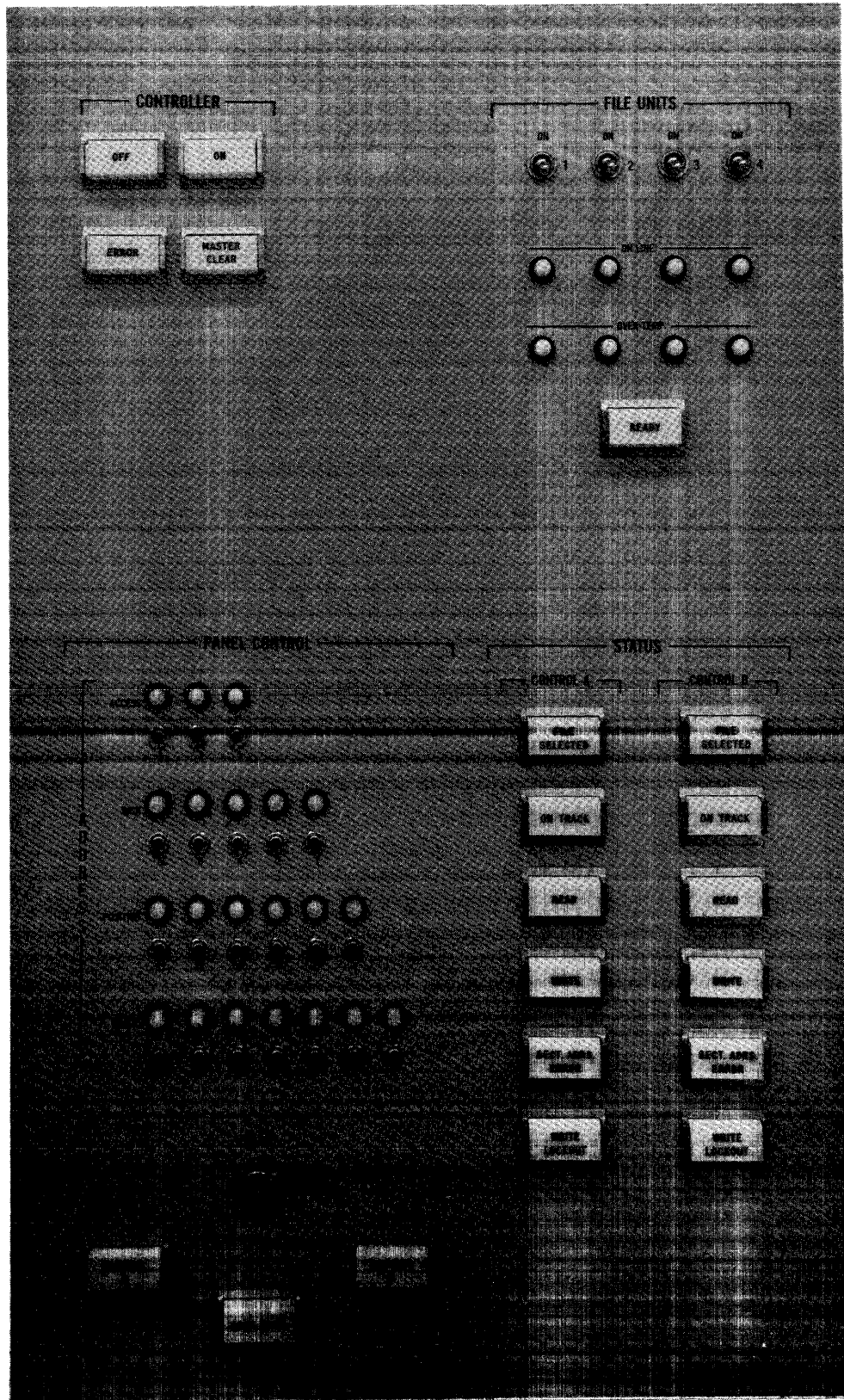

Figure B-12. Maintenance Panel Switches and Indicators

Controller OFF Switch

This switch removes power from both the controller and the file units.

Controller Error Indicator

This indicator lights to show that the controller has recognized an error condition in the disk system.

Master Clear Switch

This switch master clears the controller and file units.

Ready Indicator

This indicator lights to indicate that all file units are On Line and ready for operation.

File Unit Switches

These switches apply power to the individual file units. They must be in the Off (down) position when the controller ON switch is pressed. File unit switch 1 is associated with the unit access located immediately to the left of Control B. Switch 2 is associated with the next unit access, and so on.

On Line Indicators

These indicators light to show that the associated file units have reached operating RPM and that the read/write heads have landed (extended to operating position).

Over Temp Indicators

These indicators light to show that the temperature within the associated file units exceeds operating limits.

Panel Control Switches and Indicators

These switches and indicators are for the use of maintenance personnel. If these switches are moved during an operation with the disk, an error may be introduced into the program.

Status Indicators

These indicators show the current status of the system and are self explanatory.

FILE UNIT SWITCHES AND INDICATORS

Write Lockout Switches

The Write Lockout switches (Figure B-13) prevent accidental destruction of data on selected disks by inhibiting Write operations. There are two sets of 16 switches on a file unit, one set for each access. Each switch corresponds to one of the 16 disks in the file unit. When a switch in set A is ON, the corresponding disk cannot be written on via access 0.* The disk can be written on via access 1 unless the corresponding switch in set B is also ON.

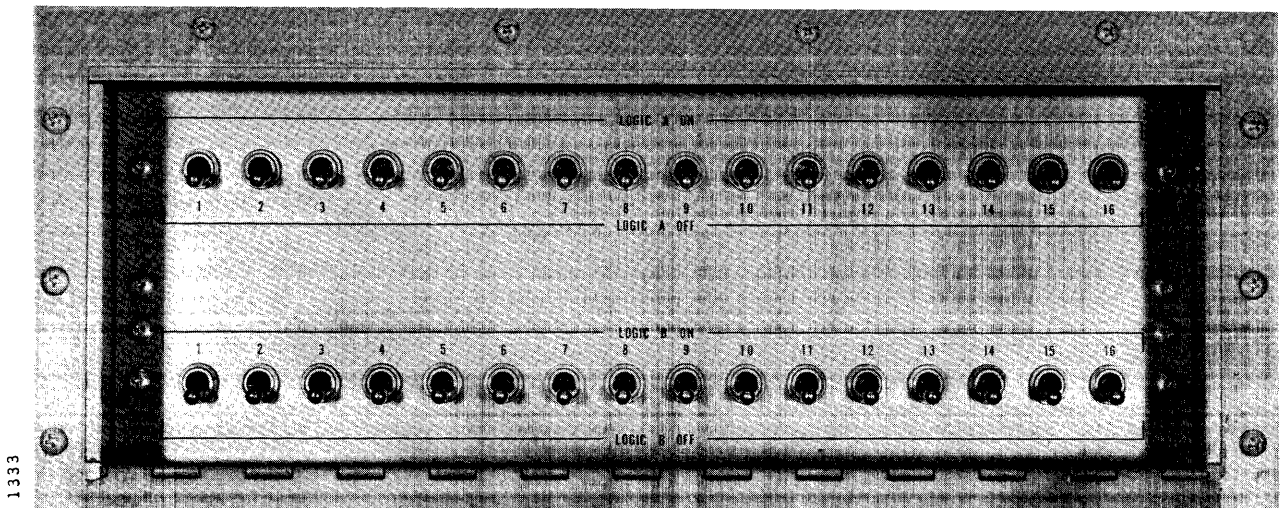

Figure B-13. Write Lockout Switches

*In the normal installation switch set A corresponds to access 0 and set B corresponds to access 1. However it is possible to reverse this arrangement by cross-connecting the cables between the file unit and the controller.

An attempt to write on a locked out disk will cause the Write Permit status bit (bit 4) to become "0". It also causes an Abnormal End of Operation interrupt if this interrupt has been selected. The disk system will respond to a Write operation in the normal manner (i. e., the operation will not hang up) but no writing or erasing will take place.

File Unit Maintenance Panel

This panel contains switches and indicators that are used primarily by maintenance personnel. Refer to the 828 Disk File Customer Engineering Instruction Manual, Pub. No. 60099400, for a description of these switches.

START-UP PROCEDURE

The disk system should be turned on only by qualified maintenance personnel. The procedure is as follows:

- 1) Inspect each file unit for
 - a. Dust build-up on the read/write heads.
 - b. Moisture in the air supply system.Refer to the Turn-On Procedure in the 828 Disk File Instruction Manual (Pub. No. 60099400) for the inspection procedure.
- 2) Make sure all File Unit switches (on the controller) are in the Off position.
- 3) Press the controller ON switch. It should light.
- 4) Turn the desired file unit switch ON. If more than one unit is to be turned on, wait at least 30 seconds before turning the next unit ON.

The file ON LINE indicator (located directly below the associated file unit switch) should light approximately 6 minutes after the switch has been turned on. The file unit is On Line when the disks are running at operating RPM and the heads are in position to do a Read or a Write operation.

The System READY indicator should light as soon as all selected files are On Line.

NOTE

The system will not become Ready if a file unit switch corresponding to a non-existent unit is turned on. Should any file that has been turned on fail to become On Line, check the associated disk file cabinet to ensure that the following indicators and switches are in the proper state (Table B-3).

TABLE B-3. STARTING CHECKLIST

FILE UNIT SWITCH	PROPER STATE (up is ON, down is OFF)
AC INPUT (Circuit Breaker)	ON
AIR	OFF
COMP	OFF
DISC MOTOR	OFF
-18V	OFF
TEST	OFF
DC PWR TEST	OFF
FILE UNIT INDICATOR	PROPER STATE
OPERABLE	Lighted
AIR ON	Lighted
TEST ON	Not lighted
ALARM TEMP	Not lighted
LOW TEMP	Not lighted
AIR FAULT	Not lighted

TURN-OFF PROCEDURE

To secure the system, place all file switches in the Off position. All switches may be secured simultaneously or individually in any order. Press the controller power OFF switch. The system is now secured.

SAMPLE PROGRAM ROUTINES

To help understand disk file systems, two sample programs are included. Both are factual programs that will operate with the disk file system. One routine is designed for a 3600 Series computer, the other, for a 160-A Computer in conjunction with a 3681 Data Channel Converter. Each routine is preceded by an accompanying flow chart of the program (Figures B-14 and B-15).

3600 SAMPLE ROUTINE

This program utilizes two Stop switch settings. If Stop switch 2 is set, the program halts after typing out the error comment. If the switch is not set, the program is automatically reinitiated at the load address point. If Stop switch 3 is set, the program stops upon completion of the routine. If the switch is not set, the routine is reinitiated at the load address point. In this latter case operation is continuous and end-around within the program until stopped manually or until an error condition is detected.

This routine selects control (equipment) 6, file 0, access 0 and disk 1. (The program assumes that the controller is connected to channel 1.) The program then loads both the address control word and the search code word and initiates a Write operation. A 32-word (48-bit) record is written on the disk. Then a Search operation is initiated on the record just written. The program searches each word in the record for equality or inequality between byte 4 of the search code word and the record word. Upon completion of the record search, the search mask is updated and a new Search is initiated on the same record. This time, an inequality between byte 4 and 3 of the search code word and the record word is searched for. Operations continue in this manner until the updating has caused a search of all four bytes to be completed.

The operation terminates whenever the Search is not satisfied (inequality detected) or when the search mask has been updated and all 4 bytes have been searched for.
(Stop switch 3 is set.)

160-A SAMPLE ROUTINE

The 160-A program selects the 3681, connects control (equipment) 1, file 0, access 0 and disk 0. The program then loads the address control word and initiates a 200_8 -word (12-bit) Write operation. Upon completion of the Write operation, the same starting address is reloaded and a Read operation reads the data back into the computer.

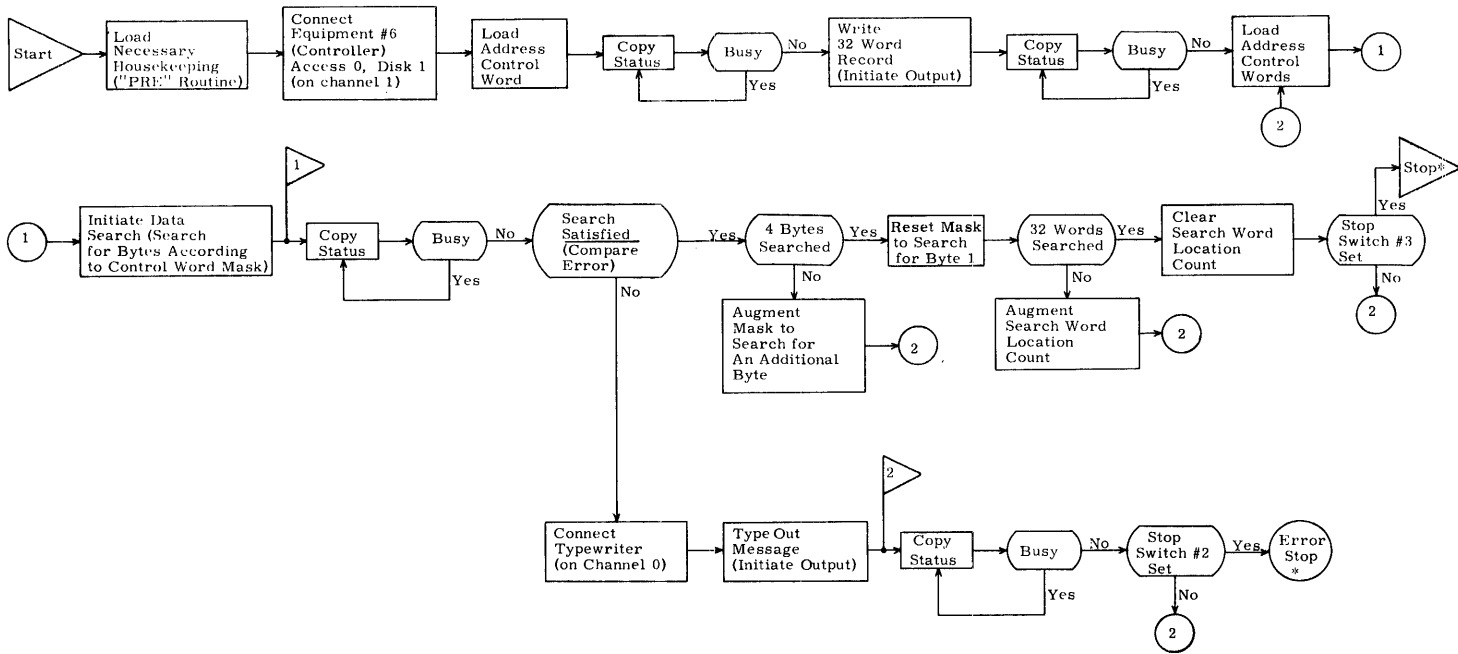

*Return to ② on restart after stop

△ Original mask search for byte 1 only

△ Typewriter types out: "DATA DOES NOT COMPARE" and does a carriage return.

Figure B-14. Flow Chart: 3600 Disk File Routine

3600 SAMPLE PROGRAM

<u>ADDRESS</u>	<u>INSTRUCTION</u>	<u>COMPASS CODING</u>	<u>COMMENT</u>
00000	50 0 00000 Start	NOP	Pass instruction
	75 4 00116	RTJ	PRE
			Return Jump to PRE, preliminary house-keeping routine.
00001	74 0 00001 A	CONN	1, 6, 1
	01 0 06001		
			Wait Reply on Connect. Connect to Channel 1; Equipment 6, File 0, Access 0, Disk (positioner) 1.
00002	74 1 00002	EXTF	1, 0051B
	01 0 00051		
			Wait Reply on Function. Select Load Address function (Channel 1).
00003	74 3 00003	BEGW	1, ADDRWC
	01 0 00031		
			Wait Reply on Function. Load Address Control Word on Channel 1 from address 00031.
00004	74 4 11000	COPY	1, 1
	01 0 00000		
			Copy Status (Channel 1).
00005	63 0 02001	NBJP	B1, 1, -1
	60 0 00004		
			Wait <u>Busy</u>
00006	74 1 00006	EXTF	1, 0041B
	01 0 00041		
			Wait Reply on Function. Select Write Data function.
00007	74 3 00007	BEGW	1, DATA CW
	01 0 00055		
			Wait Reply on Function. Begin Write; Load data (address 00055) on Channel 1.
00010	74 4 11000	COPY	1, 1
	01 0 0000		
			Copy Status (Channel 1).
00011	63 0 02015	NBJP	B1, 13, -1
	60 0 00010		
			Wait <u>Busy</u> (end of Write operation).

<u>ADDRESS</u>	<u>INSTRUCTION</u>	<u>COMPASS CODING</u>	<u>COMMENT</u>	
00012	74 1 00012 B	EXTF	1,0041B	Select Load Address (Channel 1).
	01 0 00041			
00013	74 3 00013	BEGW	1,TWOCWS	Wait Reply on Function.
	01 0 00032			Load two control words starting from address 00032.
00014	74 1 00014	EXTF	0,0044B	Wait Reply on Function
	01 0 00044			Select and initiate Data Search (Channel 1).
00015	74 4 11000	COPY	1,1	Copy Status (Channel 1).
	01 0 00000			
00016	63 0 02001	NBJP	B1, 1, -1	
	60 0 00015			Wait <u>Busy</u>
00017	74 4 11000	COPY	1,1	Copy Status (Channel 1).
	01 0 00000			
00020	63 0 02006	ZBJP	B1, 6, ERROR	
	64 0 00022			Jump to <u>ERROR sub-</u> <u>routine on Compare.</u>
00021	75 0 00037	SLJ	UPDATE	Jump to UPDATE sub- routine on Compare.
	50 0 00000			
00022	74 0 00022	ERROR CONN	0,5,0	Wait Reply on Connect.
	00 0 05000			Connect typewriter on Channel 0.
00023	74 3 00023	BEGW	0, TYPCW	Wait Reply on Function.
	00 000126			Begin typeout, Control Word at address 00126.
00024	74 4 11000	COPY	0,1	Copy Status (Channel 0).
	00 0 00000			
00025	63 0 02015	NBJP	B1, 13, 1	
	60 0 00024			Wait <u>Busy</u>

<u>ADDRESS</u>	<u>INSTRUCTION</u>	<u>COMPASS CODING</u>	<u>COMMENT</u>	
00026	76 3 00012	SS2	B	Error Stop. Stop if Stop Switch #2 is set, continue at B.
	50 0 00000			
00031	10 0 00001	ADDRCW IOTW	CW1,1	Load Address Control Word (location 00033)
	00 0 00033			
00032	10 0 00002	TWOCWS IOTW	CW1,2	
	00 0 00033			
00033	00 0 00000	CW1 OCT	0	Control Word #1.
	00 0 00000			
00034	00 0 00000	CW2 OCT	0	Control Word #2.
	00 0 00000			
00035	01 0 00000	ALPHA OCT	10000000000000	Update Search Word.
	00 0 00000			
00036	00 1 00000	BETA OCT	10000000000000	Update Search Mask.
	00 0 00000			
00037	54 2 00003	UPDATE ISK	3,2	Skip next instruction if four bytes have been searched.
	75 0 00041	SLJ	AA	Jump to AA to update byte count.
00040	75 0 00043	SLJ	BB	Jump to BB.
	50 0 00000			
00041	12 0 00036	AA LDA	BETA	
	70 0 00033	RAD	CW1	Update CW1 (mask)
00042	75 0 00012	SLJ	B	Jump to B, commence new Search operation.
	50 0 00000			
00043	50 6 00047	BB ENI	39,6	
	10 0 00000	ENA	0	Clear Mask

<u>ADDRESS</u>	<u>INSTRUCTION</u>	<u>COMPASS CODING</u>	<u>COMMENT</u>
00044	63 0 60002	SBYT, AO, E2 CW1, 6	
	50 5 00033		
00045	54 3 00037	ISK 31, 3	If 32 ₁₀ words searched, skip next instruction
	75 0 00047	SLJ AAA	Jump to AAA
00046	75 0 00052	SLJ BBB	Jump to BBB
	50 0 00000		
00047	12 3 00056 AAA	LDA DATA, 3	Load A with Data Search address location.
	20 0 00034	STA CW2	
00050	12 0 00035	LDA ALPHA	
	70 0 00033	RAD CW1	Update Search Word Location.
00051	75 0 00012	SLJ B	
	50 0 00000		
00052	50 6 00052 BBB	ENI 42, 6	
	10 0 00000	ENA 0	Clear Search Word Location in CW1.
00053	63 0 60005	SBYT, AO, E5 CW1, 6	
	50 5 00033		
00054	20 0 00033	STA CW1	
	76 3 00012	SS3 B	Stop if Stop Switch #3 is set; Re-enter program at B.
00055	10 0 00040 DATA	CW IOTW DATA, 32	Output 32 ₁₀ word data buffer to disk.
	00 0 00056		
00056 thru 00115			32 ₁₀ word data buffer.
00116	75 0 00116 PRE	SLJ	
	50 1 00000	ENI 0, 1	

<u>ADDRESS</u>	<u>INSTRUCTION</u>	<u>COMPASS CODING</u>	<u>COMMENT</u>
00117	50 2 00000	ENI	0, 2
	50 3 00000	ENI	0, 3
00120	50 6 00013	ENI	11, 6
	10 0 00001	ENA	1
00121	63 0 60001	SBYT, AO, E1	A + 1, 6
	50 5 00002		
00122	63 0 60001	SBYT, AO, E1	A + 5, 6
	50 5 00006		
00123	63 0 60001	SBYT, AO, E1	B, 6
	50 5 00012		
00124	63 0 60001	SBYT, AO, E1	B + 2, 6
	50 5 00014		
00125	75 0 00116	SLJ	PRE
	50 0 00000		
00126	10 0 00003	TYP CW IOTW	TYP, 3
	00 0 00127		
00127	63 5 51275	TYP	TYPE
	12 6 05542		3
			Typeout: "DATA DOES NOT COMPARE"
00130	51 4 66031		
	42 7 56011		
00131	42 7 25412		
	56 5 13260		

END

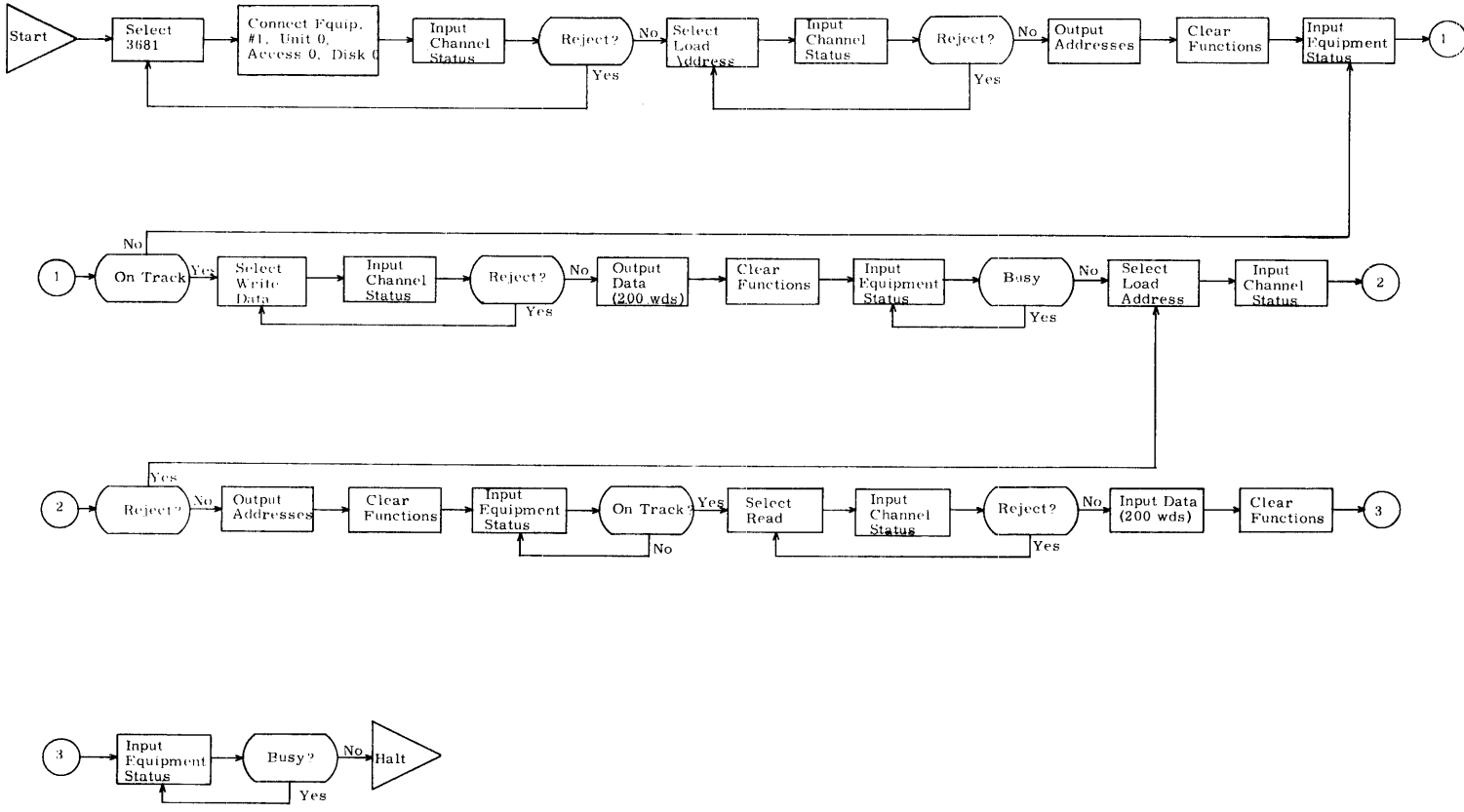

Figure B-15. Flow Chart: 160-A/3681/363X Routine

160-A/3681/ 363X SAMPLE ROUTINE

<u>ADDRESS</u>	<u>CONTENT</u>	<u>OSAS CODING</u>			<u>COMMENT</u>
0100	7500	A1	EXC	6004	Select 3681
0101	6004				
0102	2200		LDC	1000	Output Connect code
0103	1000				Connect Equipment #1 (control), Unit 0 (file), Access 0, Disk 0.
0104	7677		OTA		Connect disk file.
0105	7500		EXC	6001	Check channel status.
0106	6001				
0107	7600		INA		
0110	0201		LPN	1	
0111	6511		NZB	A1	Jump to A1 on Reject.
0112	7500	B1	EXC	6010	Initiate function.
0113	6010				
0114	2200		LDC	0051	Load addresses.
0115	0051				
0116	7677		OTA		
0117	7500		EXC	6001	Check channel status.
0120	6001				
0121	7600		INA		
0122	0201		LPN	1	
0123	6511		NZB	B1	Jump to B1 on Reject.
0124	7500		EXC	6040	Write (address).
0125	6040				
0126	7343		OUT	Word1A	Output disk address.
0127	0447			ADDRESS+2	
0130	7500		EXC	6200	Clear Functions
0131	6200				
0132	7500	B2	EXC	6002	Check equipment status.
0133	6002				
0134	7600		INA		
0135	0210		LPN	10	Confirm that address is located on track.

<u>ADDRESS</u>	<u>CONTENT</u>	<u>OSAS CODING</u>		<u>COMMENT</u>
0136	6405		ZJB B2	Wait confirmation
0137	7500	B3	EXC 6010	Initiate function.
0140	6010			
0141	2200		LDC 0041	Write Data
0142	0041			
0143	7677		OTA	
0144	7500		EXC 6001	Check channel status.
0145	6001			
0146	7600		INA	
0147	0201		LPN 1	
0150	6511		NZB B3	Jump to B3 on Reject.
0151	7500		EXC 6040	Write data block.
0152	6040			
0153	7315		OUT Words1	
0154	0445		RECORD+200	
0155	7500		EXC 6200	Clear functions.
0156	6200			
0157	7500	B4	EXC 6002	Check equipment status.
0160	6002			
0161	7600		INA	
0162	0202		LPN 2	Confirm completion of Write.
0163	6404		NZB B4	Wait confirmation (BUSY)
0164	7500	B5	EXC 6010	Initiate function
0165	6010			
0166	7101		JF1 1	
0167	0172		OVER	
0170	0245	Words1	RECORD	
0171	0445	Words1A	ADDRES	
0172	2200	OVER LDC	0051	Load address
0173	0051			
0174	7677		OTA	
0175	7500		EXC 6011	Check channel status
0176	6001			
0177	7600		INA	
0200	0201		LPN 1	
0201	6514		NZB B5	Jump to B5 on Reject
0202	7500		EXC 6040	Write (address)
0203	6040			
0204	7337		OUT Word1B	

<u>ADDRESS</u>	<u>CONTENT</u>	<u>OSAS CODING</u>		<u>COMMENT</u>
0205	0447		ADDRES+2	
0206	7500		EXC 6200	Clear functions
0207	6200			
0210	7500	B6	EXC 6002	Check equipment status
0211	6002			
0212	7600		INA	
0213	0210		LPN 10	Confirm that address is located on track.
0214	6405		ZJB B6	Wait confirmation
0215	7500	B7	EXC 6010	Initiate function
0216	6010			
0217	2200		LDC 0040	Read
0220	0040			
0221	7677		OTA	
0222	7500		EXC 6001	Check channel status
0223	6001			
0224	7600		INA	
0225	0201		LPN 1	
0226	6511		NZB B7	Jump to B7 on Reject
0227	7500		EXC 6020	
0230	6020			
0231	7214		INP Word2	
0232	1072		RECORD2+200	
0233	7500		EXC 6200	
0234	6200			
0235	7500	B8	EXC 6002	
0236	6002			
0237	7600		INA	
0240	0202		LPN 2	Confirm end of Read operation.
0241	6405		NZB B8	Wait confirmation (BUSY)
0242	7700		HLT	End of test
0243	0445	Word1B	ADDRES	
0244	0245	Word2	RECORD2	
0245	0000	RECORD2 BLR	200	200-word storage location.
0445	0000	ADDRES BLR	2	2-word address location

END

SECTION C

3234-A MASS STORAGE CONTROLLER

CONTENTS

Functional Description	C-2	Restore (Strip File)	C-40
Subsystem Configuration	C-2	Interrupts	C-40
3234 Controller (Including Special Option 60076)	C-3	Abnormal EOP Interrupt	C-41
Peripheral Storage Devices	C-4	Seek/Sector Verification	C-41
Data Format	C-10	Overlap Seek	C-41
Sector Format	C-11	1X and 4X Function Codes	C-42
Checksum	C-12	Records	C-42
Data Transfer	C-13	Strip File	C-43
Access Time	C-14	Disk Storage Drives	C-43
1738 Compatibility	C-15	Unsafe Conditions	C-44
Codes	C-15	Sector Timing	C-45
Connect Code	C-17	Buffer Timing	C-46
Function Codes	C-18	Manual Operation	C-47
Status Codes	C-25	Power Sequence	C-47
System Errors and Performance	C-31	Loading and Unloading Procedures	C-48
Addressing	C-35	Ready State	C-52
Programming Considerations	C-39	3234 Control Panel	C-54
Connect	C-39	Sample Program Routines	C-60
Simultaneous Connect	C-39	Program Sequence	C-61
Mode Restrictions	C-39	Program A	C-61
Master Clear, Release and Disconnect	C-39	Program B	C-65

FIGURES

C-1 Typical Configuration	C-2	C-13 Function Code Format	C-18
C-2 Disk Pack and Data Cell	C-3	C-14 Disk File Address Format	C-36
C-3 Cylinder Concept of Data Recording		C-15 Disk Storage Drive Address Format	C-36
C-4 813/814 Cabinet	C-5	C-16 Strip File Address Format	C-37
C-5 Disk File Physical Layout	C-6	C-17 Cell Indicator and Elevating Door	C-50
C-6 853 Disk Storage Drive	C-8	C-18 Cell Array	C-51
C-7 2321 Data Cell	C-9	C-19 Cell, Cell Cover, and Protective Container	C-52
C-8 Array Subdivisions	C-9	C-20 3234 Maintenance Control Panel	C-54
C-9 Sector Format	C-11	C-21 Flow Chart, Program A	C-62
C-10 Disk Pack Storage Arrangement	C-12	C-22 Flow Chart, Program B	C-66
C-11 Block Diagram: Cyclic Encoder	C-12		
C-12 Connect Code Format	C-17		

TABLES

C-1 Unit Storage Format and Capacity	C-10	C-3 Strip File Address Conversion Charts	C-38
C-2 3234 Mass Storage Controller Codes	C-15		

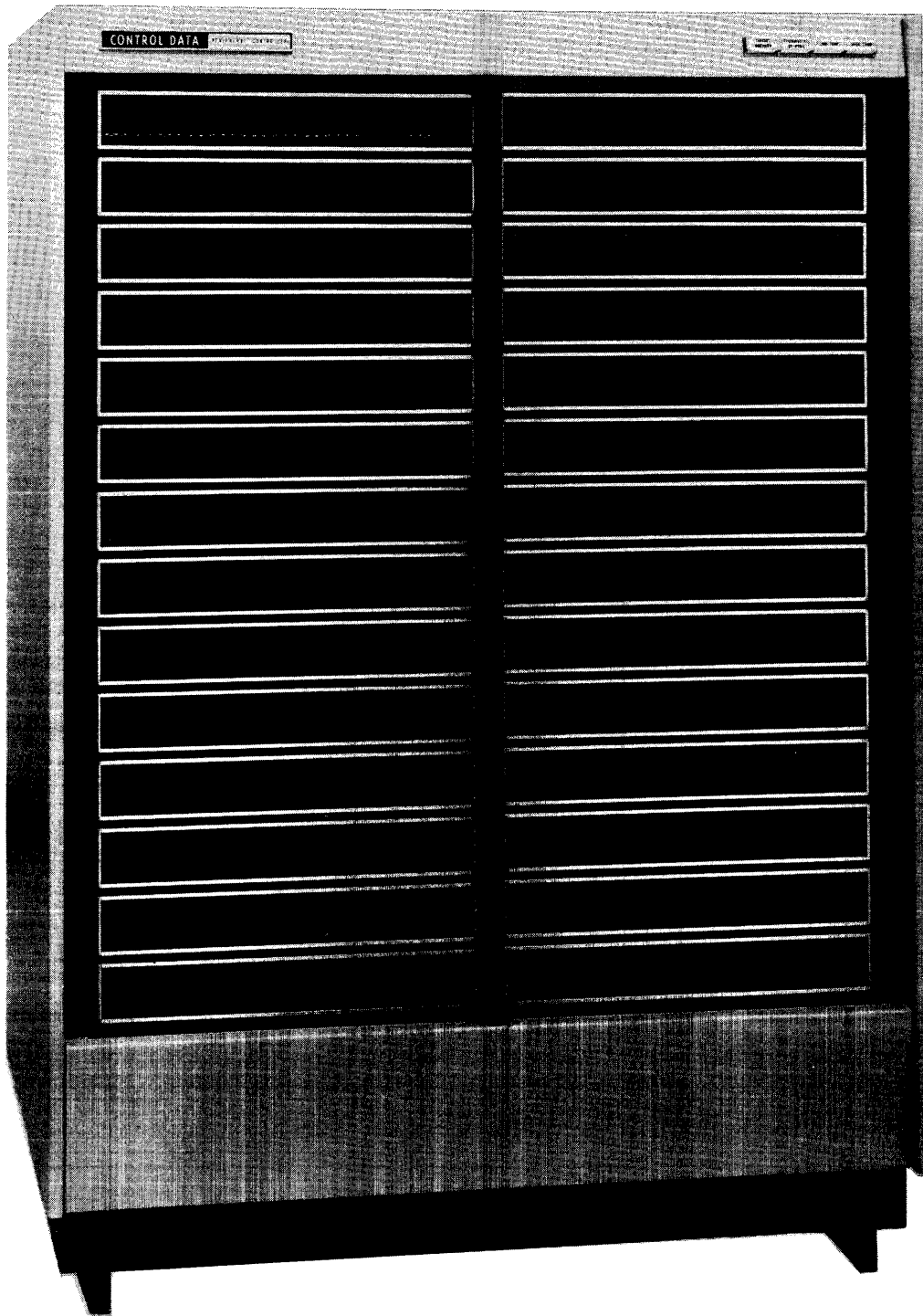

3234
Rev G

3234-A MASS STORAGE CONTROLLER

3234-A MASS STORAGE CONTROLLER

This section describes a mass storage subsystem consisting of the CONTROL DATA® 3234-A Mass Storage Controller, CONTROL DATA 3000 Series data channels, and the following peripheral storage devices: CONTROL DATA 813/814 Disk File, CONTROL DATA 853/854 Disk Storage Drive and IBM® 2321 Data Cell*. It includes relevant system specifications, programming procedures, codes, manual operating information and sample program routines. It is assumed the reader is familiar with 3000 series logic, instructions, and procedures.

The following terms are used throughout this section and are defined here for clarification:

- Controller (or 3234) - The 3234 Mass Storage Controller which provides the logic interface between the peripheral units and the data channel(s) and the cabinet in which the logic is housed.
- Special Option 60076 (adaptor) - The special adaptor chassis (housed in the 3234 controller cabinet) which is necessary to interface the controller logic to the strip file.
- Disk File - Either the 813 or 814 Disk File unit and cabinet in which the disks and associated electronics are housed.
- Disk Drive - Either of the 853 or 854 Disk Storage Drive units, their associated disk pack, and the cabinet in which the pack and associated drive unit logic are housed.
- Disk Pack - The 850 Disk Pack assembly consisting of 10 recording disks mounted on a common vertical axis. Each disk is approximately 14 inches in diameter. The packs are portable and interchangeable among various disk drive units.
- Strip File* - The 2321 Data Cell Storage unit and the cabinet in which the cells, subcells, strips, and associated logic and electronics are housed.
- Data Cell - The strip file storage assembly. Each cell consists of 20 subcells each containing 10 recording strips. The cells are portable and interchangeable between the various strip file units. A full complement of 10 cells (either data or ballast) is required to complete the array necessary for strip operations.

* Throughout the manual the IBM 2321 Data Cell will be referred to as the strip file.

- Ballast Cell - A dummy cell used to maintain the proper balance of the array when less than a full complement of data cells is used.

Figure C-2 shows a disk pack and a data cell in their protective containers.

FUNCTIONAL DESCRIPTION

The 3234 Controller, in conjunction with the above peripherals (singly, or in any combination), operates as a mass storage subsystem having medium access time, nonvolatile, mass storage facilities. The subsystem provides large volume data storage with random access and interchangeable storage pack and data cell capabilities.

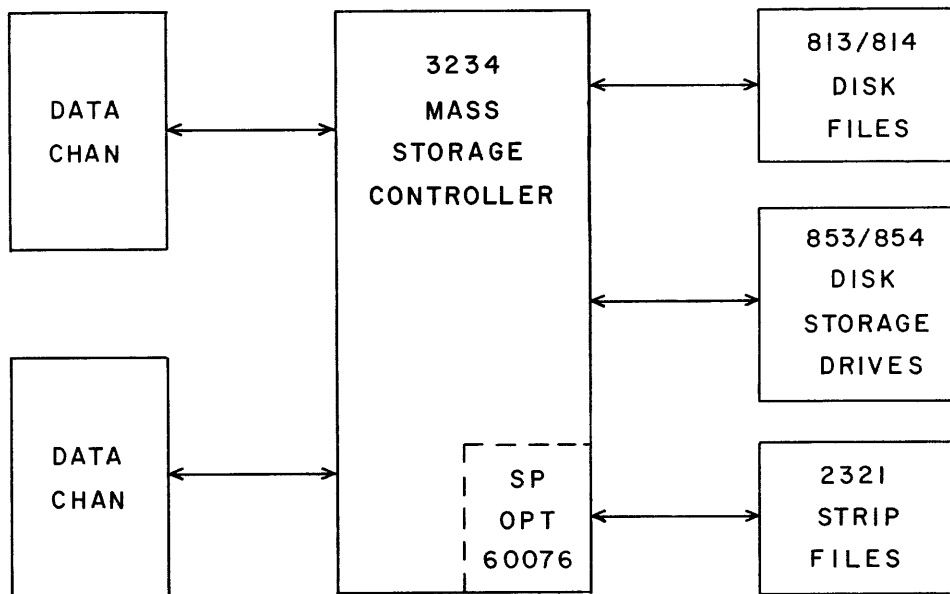
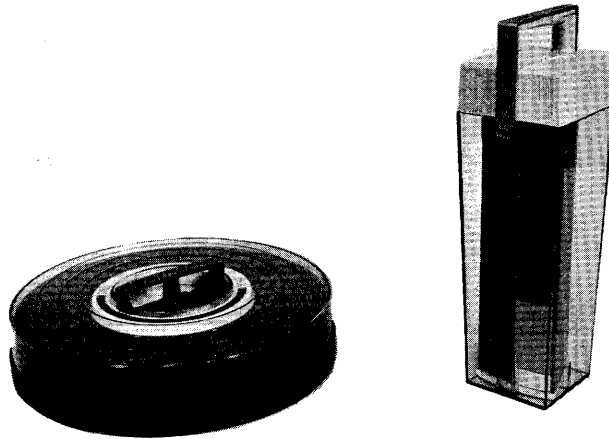

Figure C-1. Typical Configuration

SUBSYSTEM CONFIGURATION

The mass storage subsystem has expandable capabilities. The minimum subsystem consists of a single 3000 Series data channel, the 3234 Mass Storage Controller, and one of the storage devices. The subsystem can be expanded via the addition of a second data channel and additional storage units. When two data channels are connected in the subsystem they operate on a time-shared basis.

The maximum subsystem consists of two data channels, the 3234 Mass Storage Controller and up to a total of eight* peripheral storage devices. To incorporate strip file units into the subsystem, the adaptor chassis (Special Option 60076) must be added to the controller. The adaptor can accommodate up to four strip file units.



2168

Figure C-2. Disk Pack and Data Cell

The types of storage units used in the subsystem may be intermixed in any combination, or may be all of one type; however, no provision is made for more than one adaptor in the 3234. Therefore, no more than four strip files may be connected to the controller.

The subsystem operates under program control from the computer. A 12-bit connect code selects the equipment (controller) and the unit (peripheral storage device). The 12-bit function codes provide for selecting operating modes, interrupts, and loading and unloading address information.

3234 CONTROLLER (Including Special Option 60076)

The standard 3000 Series signals are exchanged between the controller and the data channels. The controller (shown in the frontispiece) provides an interface between the select storage units and the computer via the data channels. The controller translates

* The 814 Disk File is considered as two storage units.

the Connect Code and the Function codes issued by the computer to control peripheral operation. The controller buffers data between the peripherals and the data channels. It accepts data from the data channels in a parallel format, disassembles it, and transmits the data serially to the appropriate storage unit. In a similar manner, the controller accepts serial data from the selected storage unit, assembles it into 12-bit bytes, and transfers it in parallel to the appropriate data channel.

The computer controls the subsystem operations through the 12-bit function codes and a 24-bit address word. Issuing a function code specifying the mode of operation prepares the controller and selected peripheral unit for an I/O operation. The issuance of a function Load Address code causes the controller to prepare for a Seek operation* within the selected storage unit. Subsequent to the issuance of the Load Address code, the computer must do a Write operation to issue output data containing address information to the controller. The data is loaded into the Address register of the controller and the Seek operation commences immediately upon termination of the output operation. If the Address loaded is a legal address, the selected storage unit seeks the position specified by the contents of the register in the controller.

A Sector Verify operation automatically commences upon initiation of the I/O at the location specified by the address. If no Load Address operation is performed prior to receipt of a Read or Write signal, the I/O operation commences at the address presently held in the address register (cylinder and sector plus 1; location at which the previous operation ended)** except when a unit is at the last legal address. In the latter case, a new Seek must be initiated, or an Address Error is generated.

PERIPHERAL STORAGE DEVICES

The five types of peripheral storage devices encompass a variety of mass storage units with which the computer may communicate. All of the units utilize a ferrous oxide coating as the magnetic recording medium.

The disk units (file and drive) use the cylinder concept (Figure C-3) of recording to provide optimum efficiency by minimizing physical (positioner) movement. In this concept the data is read (and written) consecutively from sector to sector within a track and from a track on one side of a disk to the same track on the opposite side of the same disk to the

* An operation in which the R/W heads are physically positioned to the addressed cylinder.

** When an I/O operation is in progress (or ends) the controller automatically updates the address registers at the end of each sector except when an Address Error is detected, or when the abnormal EOP interrupt is selected and an abnormal condition occurs.

same track on the next sequential surface of the next disk, and so on. This process (which takes place by means of the electronic switching from one R/W head to the next to provide minimum access time) takes place throughout the entire set of disks in the stack. The final result is a sequential multiple of records on the disks in a cylindrical drum pattern.

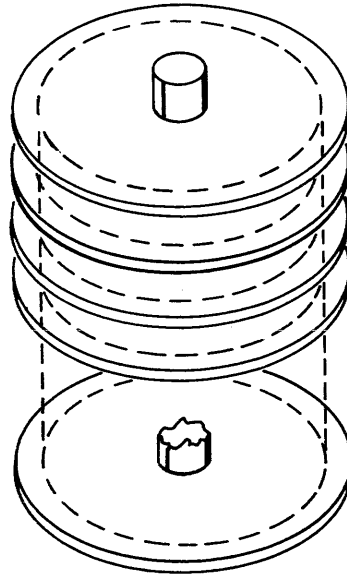

Figure C-3. Cylinder Concept of Data Recording

Disk Files

The 813 and 814 Disk Files are contained in similar cabinets (Figure C-4). Each cabinet contains two drive spindles. A stack of 18 disks can be mounted on each half of the spindle (Figure C-5). The 18 disks provide a total of 32 recording surfaces. Each stack is subdivided into two groups; the top and bottom surfaces of each group are not used for recording. The spindles rotate (non-synchronously) at approximately 1180 rpm less induction slip.

Each disk is approximately 26 inches in diameter; each stack is approximately 18 inches high.

The 813 Disk File contains two stacks of disks mounted on the upper half of the spindles. A single hydraulically positioned access assembly serves the two stacks with two separate horizontally opposed groups of R/W head arms. Mounted on the end of each head arm are two head pads, each containing four R/W heads. There are four R/W heads for each of the 32 recording surfaces in a stack. The accesses (which move simultaneously in

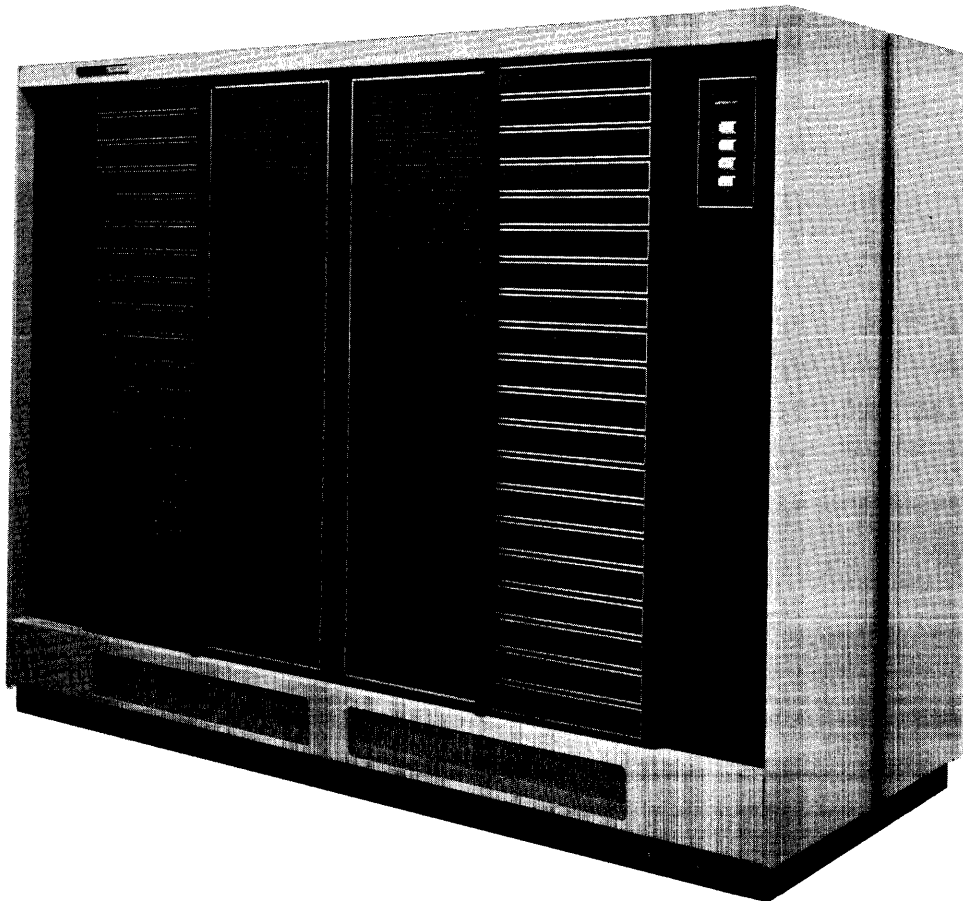

306

Figure C-4. 813/814 Cabinet

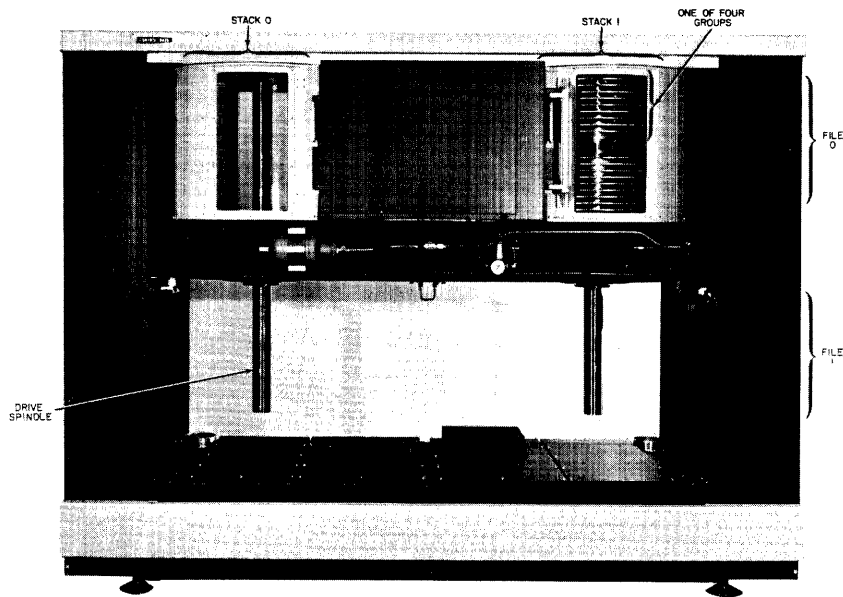

Figure C-5. Disk File Physical Layout

2358

opposite directions) can be positioned to any of 64 positions to provide a total of 128 recording cylinders (64 per stack).

The 814 Disk File contains four stacks mounted on the two spindles. Two independent hydraulically positioned access assemblies serve the four stacks. Each half (upper disks and positioner, or lower disks and positioner) of the 814 is considered as an independent unit and is addressed, accessed, and operated on independently. Thus access and operation to either half of an 814 is identical to the accessing and operation in an 813.

Disk Storage Drives

The disk storage drives (Figure C-6) are random access storage devices. The access mechanism consists of ten arms mounted in pairs on a movable carriage. Each pair of arms is positioned between two disks. A single R/W head is mounted on the extremity of each arm. On an initial Seek (performed by loading a disk pack, closing the cover, and pressing the START switch) the carriage moves horizontally from an initially retracted position (to facilitate disk pack insertion and removal) to the first track near the edge of the disk. The unit then moves the heads to the innermost track (a distance of two inches from the initial position) and then withdraws the heads back to track 000. During the latter process, the heads are loaded (put in a recording attitude near the surface of disks).

The 853 and 854 Disk Storage Drives are contained in similar cabinets. The 853 has provisions for positioning to 100 cylinders; the 854 for positioning to 202 cylinders. Both types utilize the standard 850 Disk Pack; however, because positioning methods are different in the two types of devices, a pack recorded on one type (e. g. , 853) cannot be read on the other type (e. g. , 854). The packs rotate at approximately 2400 RPM.

Data Cell (Strip File)

The Data Cell (Figure C-7) is a direct access storage device. The unit is capable of retrieving and restoring individual magnetic storage strips from an array of cells. The data is written and read from the strips which are approximately 13 inches long, 2-1/4 inches wide and 0.005 inch thick. Each strip is coated on one side with an iron oxide recording medium and on the other side with an anti-static carbon coating.

Each file contains 2000 strips set in an array consisting of 10 removable cells and arranged in a vertical cylinder (Figure C-8). Each cell is subdivided into 20 subcells with 10 recording strips per subcell. During operation, the array is hydraulically positioned (in the direction of least travel) to any of the 200 subcells. A mechanical linkage then selects the addressed strip, pulls it from its storage location, and places it on a small

drum. The drum rotates the strip past a R/W head bar assembly. The assembly contains 20 R/W heads and can be positioned to any of five locations to provide access to the 100 recording tracks on the strip. When use of the strip is completed it is restored to its original storage location in the subcell.

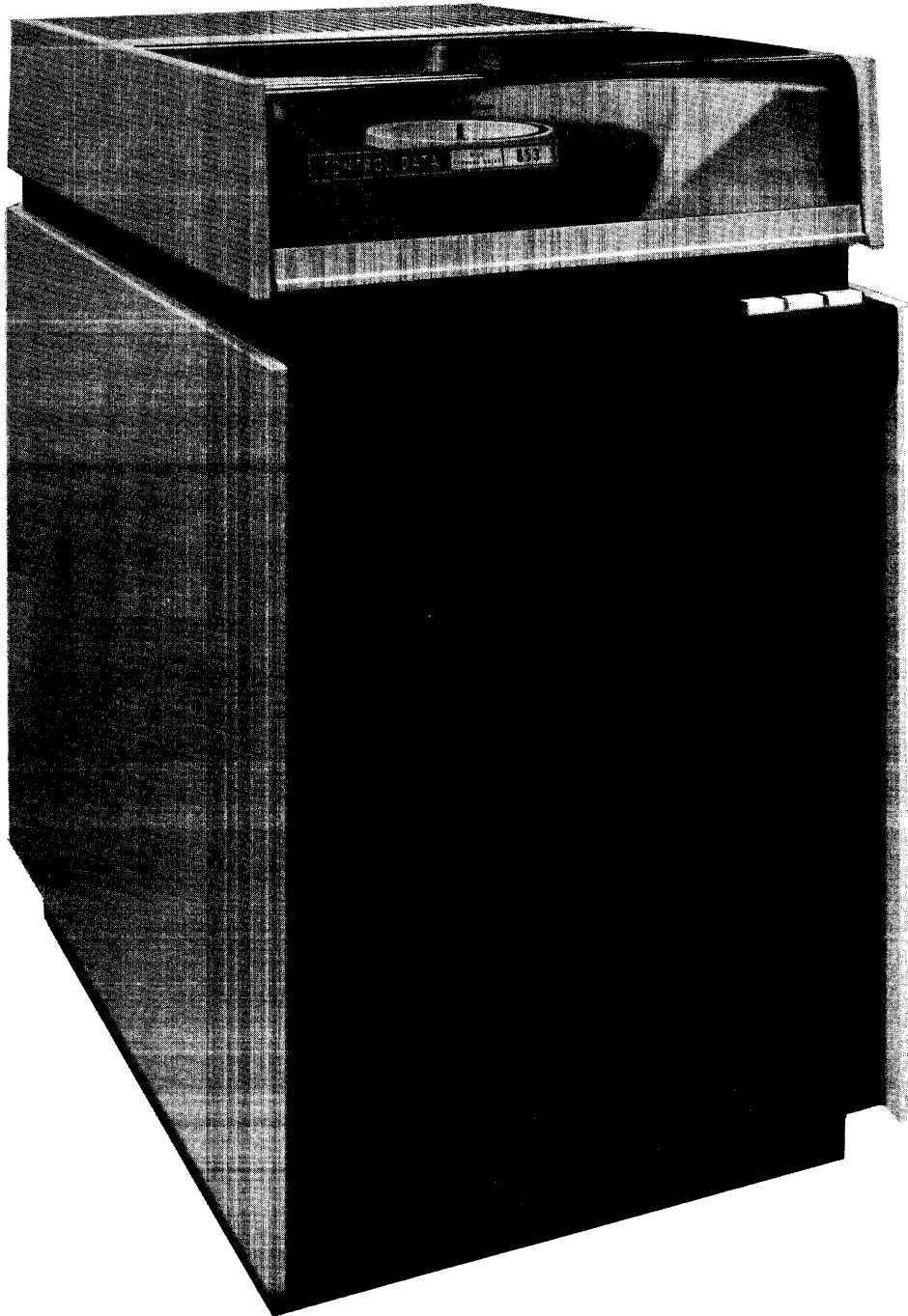

Figure C-6. 3535 Disk Storage Drive

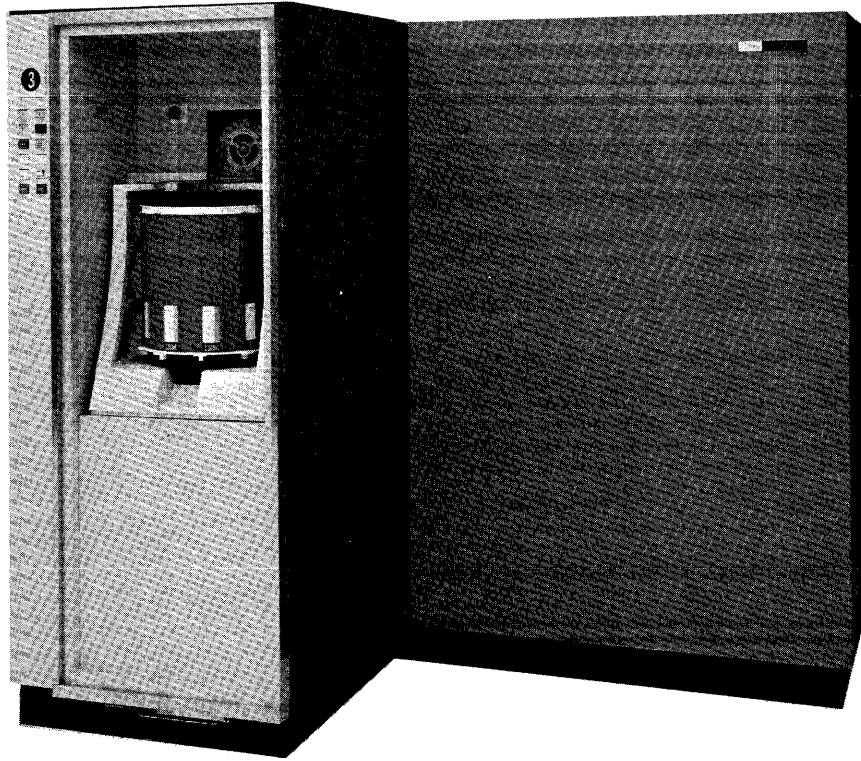

Figure C-7. 2321 Data Cell

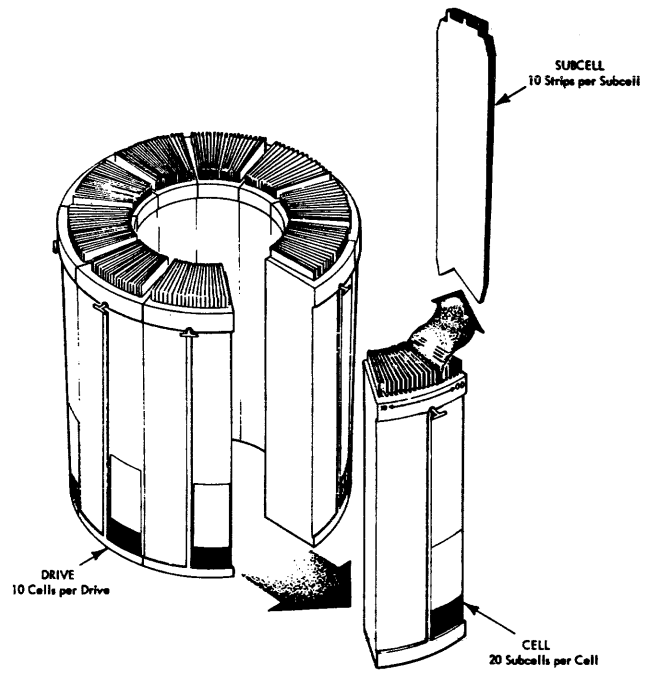

Figure C-8. Array Subdivisions

DATA FORMAT

The basic data word consists of a 12-bit byte. Multiple bytes are recorded in each sector with multiple sectors recorded in each of the storage mediums. Physical arrangement of the tracks and cylinders in the storage devices varies dependent upon the device. Table C-1 indicates the sector, track, and cylinder formats for the various storage devices.

TABLE C-1. UNIT STORAGE FORMAT AND CAPACITY

UNIT DIVISION	813	814	853	854	2321
Byte	12 bits per byte (All Units)				
Sector	128 bytes (1536 bits)	128 bytes (1536 bits)	128 bytes (1536 bits)	128 bytes (1536 bits)	1380 bytes (16,560 bits)
Track	32 Sectors (49,152 bits)	32 Sectors (49,152 bits)	16 Sectors (24,576 bits)	16 Sectors (24,576 bits)	1 Sector (16,560 bits)
Cylinder	128 Tracks (6,291,456 bits)	128 Tracks (6,291,456 bits)	10 Tracks (245,760 bits)	10 Tracks (245,760 bits)	20 Tracks (331,200 bits)
Access	128 Cylinders (805,306,568 bits)	128 Cylinders (805,306,568 bits)	NA*	NA	NA
Strip	NA	NA	NA	NA	5 Cylinders (1,656,000 bits)
Subcell	NA	NA	NA	NA	10 Strips
Cell	NA	NA	NA	NA	20 Subcells (331,200,000 bits)
Unit Total Capacity	1 Access (805,306,568 bits)	2 Accesses (1,610,612,936 bits)	100 Cylinders (24,576,000 bits)	200 Cylinders (49,152,000 bits)	10 Cells (3,312,000,000 bits)

NA = Not applicable

SECTOR FORMAT

Figure C-9 shows the basic sector format used in the peripheral storage devices. While only the data field in each sector can be changed by the program, the entire format is indicated as an aid in understanding the make-up of each sector in the track. Figure C-10 shows disk, track, and sector organization for a disk pack (the disk file is similar).

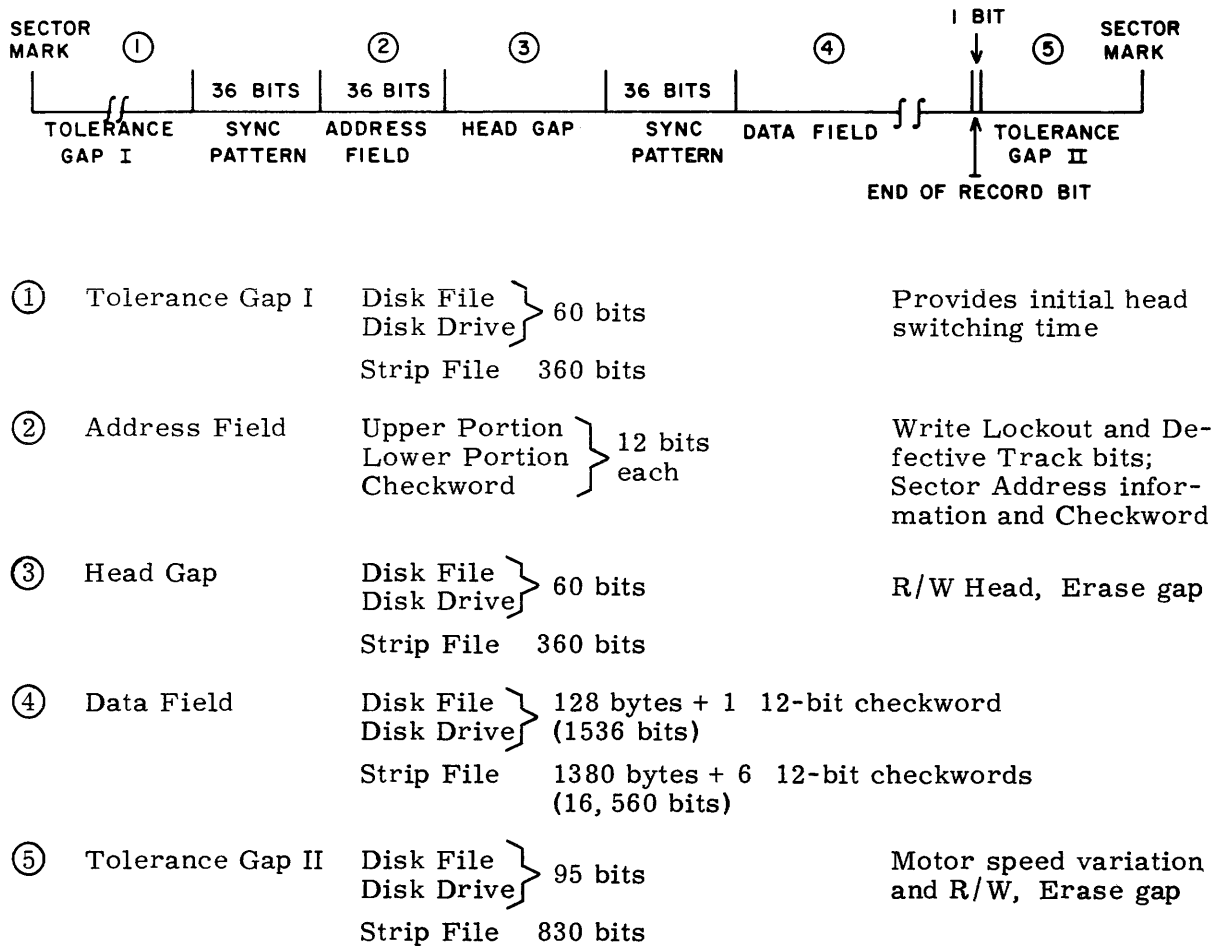

Figure C-9. Sector Format

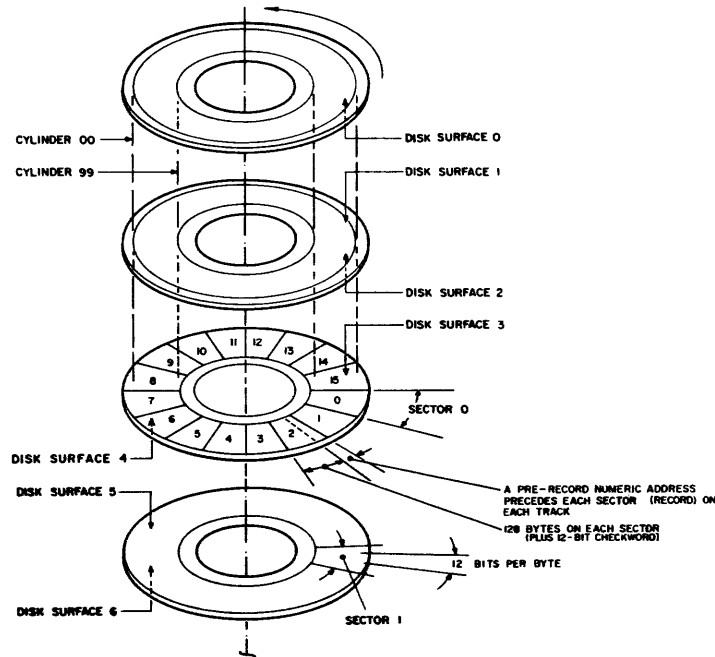

Figure C-10. Disk Pack Storage Arrangement

CHECKWORD

Address and data transfers are checked for accuracy by generation of a 12-bit redundant checkword in the controller. During operations the controller generates and verifies checkwords to determine the correctness of addresses and data transferred between the controller and the various peripheral storage devices.

As data (or addresses) are read or written each bit is also fed into the cyclic encoder. As the data (or addresses) enters the encoder it is shifted through the encoder and half adder stages (A, B, C, D and E, Figure C-11) continuously until the last bit of data or address is entered. The remainder is a cyclic code generated from the address or data being transferred. The checkword is obtained by dividing the address or data (which is taken as a code polynomial) by the polynomial $X^{12} + X^{11} + X^3 + X^2 + X + 1$ (Figure C-11).

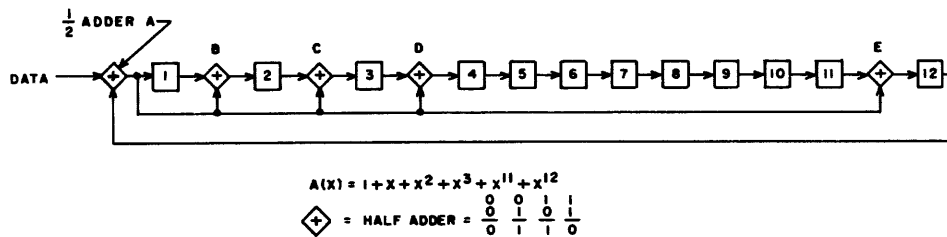

Figure C-11. Block Diagram: Cyclic Encoder

The checkword is the 12-bit code left in the cyclic encoder after the last bit of address or data has entered the encoder. This is then written immediately following the address when the address is originally written or at the end of the sector for each Write function (six checkwords are written per sector in the strip file). During subsequent address verification or Read operations the address or data being read is again fed into the encoder and a new checkword generated. The checkword previously written then enters the encoder, and if the original data was written and read correctly the two checkwords cancel each other such that the encoder ends up in a clear state. (If any stage of the encoder is set upon completion of the operation, an error has occurred in either the original writing on the storage unit or during the subsequent Read operation and a Checkword Error indication is generated.)

The theory behind the design and operation of the cyclic encoder (cyclic code) is a rather complex mathematical concept and formula.* Suffice it to say the error detection capability of the cyclic encoder is extremely accurate and falls within the following limits, where a burst equals the number of bits between any two bits in error:

- 1) If a burst is 12 bits or less, all errors are detected.
- 2) If a burst is 13 bits; an undetected error will occur approximately every 2^{-11} (one out of every 2048 errors will be undetected).
- 3) If a burst is 14 bits or greater an undetected error will occur approximately every 2^{-12} (one out of every 4096 errors will be undetected).

DATA TRANSFER

Data is addressed and written in a storage unit in discrete blocks (sectors); however, the data channel can read or record as little as one byte or as many bytes as necessary to reach the end of file or end of cell (in the case of the strip file). When reading or writing, the operation must commence at the start of a sector. When writing, if less than a full sector is written, the remainder of the sector is automatically filled with zeros. The nominal data transfer rate is:

Disk File	98,000 bytes/second
Disk Drive	100,000 bytes/second
Strip File	36,000 bytes/second

* For a description of cyclic code theory in general refer to "Error Correcting Codes" by W. Wesley Peterson, MIT Press. For a detailed description of the type of cyclic encoder used in this controller refer to "A Study of Methods of Error Detection During Transmission of Binary Information" by Carl Superko, Control Data Corporation.

Timing diagrams which indicate the relationship between the Data signals and the Reply signals during buffered operations are shown under Programming Considerations.

ACCESS TIME

Access time is equal to the cylinder-positioning time plus the rotational-latency time. The following maximum positioning times were achieved as an average over several maximum positioner moves. Maximum access time is the sum of maximum positioning time plus maximum latency time. Average access time is the sum of average positioning time plus average latency time.

Disk File

Maximum Access Time	162.9 ms
Average Access Time	95.7 ms
Maximum Positioning Time (major move)	110 ms
Maximum Positioning Time (minor move)	25 ms
Average Positioning Time (1/3 of max move)	70 ms
Maximum Latency	51.4 ± 1.5 ms
Average Latency	25.7 ms

Disk Storage Drive

Maximum Access Time	190 ms
Average Access Time	107.5 ms
Maximum Positioning Time	165 ms
Average Positioning Time (1/3 of max move)	95 ms
Cylinder to Cylinder Positioning Time	30 ms
Maximum Latency	25 ± .5 ms
Average Latency	12.5 ms

Strip File

Access time is defined as the interval from the issuance of a Seek command from the controller to the 2321 until the generation of a Strip Ready signal in the 2321. This includes time to restore a previously addressed strip, (if required). Average access times under varying conditions are as follows:

Move Head Bar (can be overlapped with other motions)	95 ms
Select Head R/W element	0.1 ms
Maximum latency	50 ± 0.65 ms
Restore Strip	200 ms

<u>Strip Seek Time Without Restore</u>	<u>Number of Subcells Moved</u>	<u>Strip Seek Time With Restore</u>
175 ms	0	375 ms
250 ms	1	450 ms
350 ms	50	550 ms
400 ms	100	600 ms

1738 COMPATABILITY

Certain design and operating compatibility exists between the 1738 Disk Drive Subsystem and the 3234 Mass Storage Subsystem. For a complete explanation refer to Disk Storage Drives under Programming Considerations.

CODES

Table C-2 lists all codes applicable to the 3234 Mass Storage Controller and associated subsystem. A complete explanation of each code follows the table.

TABLE C-2. 3234 MASS STORAGE CONTROLLER CODES

CONNECT	
Connect 3234 and Storage Unit	N0DU*
FUNCTION	
Release and Disconnect	0000
Restore	0001
Clear	0005
Load Address	0010
Return Address	0011
Select Interrupt on Ready and Not Busy	0020
Release Interrupt on Ready and Not Busy	0021
Select Interrupt on End of Operation	0022
Release Interrupt on End of Operation	0023

* N = equipment number of controller

D = device type (1 = Disk Drive; 2 = Disk File; 3 = Strip File)

U = unit number of storage device

TABLE C-2 (Cont'd)

Select Interrupt on Abnormal End of Operation		0024
Release Interrupt on Abnormal End of Operation		0025
Select Interrupt on Opposite Channel Release		0026
Release Interrupt on Opposite Channel Release		0027
Select Interrupt on End of Seek		0030
Release Interrupt on End of Seek		0031
Read		0040
Write		0041
Search Compare		0042
Masked Search Compare		0043
Keyword Verify		0044
Read Keyword		0045
Magnitude Search (Record \leq Buffer)		0050
Magnitude Search (Record \geq Buffer)		0051
Equality Search (Record = Buffer)		0052
Buffer Mode		0053
End of Record Mode		0054
STATUS		
Ready	0	XXX1
Busy	1	XXX2
Abnormal/Unavailable	2	XXX4
On Sector	3, $\bar{2}$	XX10
Address Error	3, 2	XX14
No Compare	4, $\bar{2}$	XX20
Lost Data	4, 2	XX24
End of Record	5, $\bar{2}$	XX40
Keyword Error	5, 2	XX44
Write Lockout on Read (normal)	6, $\bar{2}$	X1X0
Write Lockout on Write (abnormal)	6, 2	X1X4
Positioner Ready	7	X2XX
End of Operation Interrupt	8	X4XX
Abnormal End of Operation Interrupt	9	1XXX
Seek Interrupt	10	2XXX
Reserved	11, $\bar{2}$	4XX0
Defective Track	11, 2	4XX4

CONNECT CODE

Connect 3234 and Storage Unit (N0DU)

The 12-bit Connect code (Figure C-12) designates the equipment (controller), the peripheral device type (disk drive, disk file, strip file), and the unit with which the computer is to communicate.

Reservation capability is set up on a data channel basis. Once the data channel is connected to the controller and unit, the controller and unit are reserved until specifically released by that channel via a MC, channel clear, or Release and Disconnect function code.

Upon receipt of the Connect code by the controller, a Reply or Reject is returned to the data channel. If the desired controller, device, and unit are available, a Reply is returned immediately. If the controller is unable to accept and perform the connect, a Reject is returned. Upon receipt of a Reject, the computer must request a status response and interrogate the status bits in order to determine whether the Reject was a result of the controller being reserved, the storage type being nonexistent, or the unit being unavailable. Refer to explanation of status response bits Unavailable (XXX4) and Reserved (4XXX).

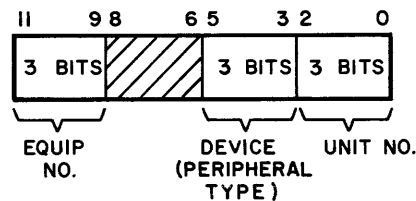

Figure C-12. Connect Code Format

Bits 0-2

These 3 bits designate the logic unit number (0-7) with which the program communicates. The number designated is variable from 0-7 by means of the unit designation jumper wires located on the maintenance control panel (Figure C-20).

Bits 3-5

These 3 bits designate the type of peripheral device with which the program is to communicate. All other device codes are illegal and cause a Reject to be issued.

XX1X	Disk Drive
XX2X	Disk File
XX3X	Strip File

Bits 6-8

Unused

Bits 9-11

These 3 bits designate the equipment with which the program desires to communicate. The number designating the equipment (controller) is variable from 0-7 by means of the rotary Equipment Number switch located in the controller cabinet.

FUNCTION CODES

The 4-digit octal function codes (Figure C-13) are divided into four major categories. The upper two digits of the code are not translated; however, for the sake of simplicity and standardization it is recommended that these bits always be "0's". The categories are:

- 1) Control codes (000-) and address codes (001-) which affect reservation of the controller and peripheral units and positioning of the R/W heads (in the disk drive and disk file) or the status of the storage medium (in the strip file), and Address and Seek operations.
- 2) Interrupt codes (002- and 003-) which set and remove interrupt selections.
- 3) I/O codes (004-) which affect and define I/O operations.
- 4) Mode Select codes (005-) which affect and modify the 0042 Search Compare code, and select and determine the operating mode and its termination.

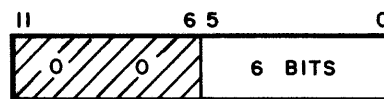

Figure C-13. Function Code Format

A Reject is issued upon receipt of a function code whenever the controller is busy with an operation other than a seek.

A Reply is issued upon receipt of an unassigned function code, but the code does not produce action in the controller.

Control and Address Codes

The control codes provide the computer with a means of releasing the subsystem removing all reserves, I/O selections, interrupt signals, and deselecting the data channel, and restoring the recording strip (in the case of the strip file) thus reducing the address time on future references to new strips. The address codes are used to address the selected storage unit or to return the current address. In either case the address is loaded into or taken from the controller Address register. The address format varies for each type of storage unit. (Refer to Addressing for complete address and format information.)

Release and Disconnect (0000)

This code logically releases the subsystem from the data channel. It causes all reserves to be removed, clears all interrupt signals, removes all I/O code selections (it does not affect mode selections), clears the read parity and write check error conditions, and drops the status response lines.

Restore (0001)

Dependent upon the type of device selected, this code causes the following:

- Disk Drive - This code initiates a seek to position (cylinder) zero of the disk pack.
- Disk File - This code causes the positioners to move out of the recording area.
- Strip File - This code causes the file to restore the recording strip to its proper subcell location. If no strip is presently loaded, the code is ignored (No-Op).

Use of this code, in conjunction with the strip file, reduces strip wear as well as access time of possible future requests to a different strip.

Clear (0005)

This code clears all major components in the subsystem, but does not affect the connect, reserved, or unit select status of the subsystem.

Load Address (0010)

This code causes the next output data to be loaded into the 24-bit controller Address register. The data is continuously loaded into the Address register (in the format indicated under Addressing), until the output operation terminates. On completion, a Seek

operation is automatically initiated in the selected storage unit. All subsequent Load Address functions to the same storage unit are rejected until the seek is completed (or it is determined that the seek will be incomplete).

Return Address (0011)

This code, in conjunction with an input operation, causes the controller to return the content of the 24-bit Address register to the data channel. The address is continuously returned (in the format indicated under Addressing), until the input operation terminates.

Interrupt Codes

These codes establish and remove the interrupt selections which determine which conditions send an Interrupt signal to the data channel.

A manual Master Clear or Channel Clear removes all interrupt selections (except the Interrupt On Opposite Channel Release for the channel that is reserved).

An Interrupt signal may be dropped by a manual Master Clear, Channel Clear, or any function code including reselecting the same selection.

Select Interrupt on Ready and Not Busy (0020)

Selection of this code causes the interrupt line to be activated and the associated status bit set the next time the subsystem becomes Ready and Not Busy (at the end of the next operation). For an explanation of Ready and Not Busy conditions, refer to the associated status response bit description.

Release Interrupt on Ready and Not Busy (0021)

This code removes the associated interrupt selection set up by the 0020 code. No interrupt notification of Ready and Not Busy is sent until the condition is reselected.

Select Interrupt on End of Operation (0022)

This code causes the interrupt line to be activated and the associated status bit to be set on completion of the next operation whether the end of operation is normal or abnormal.

Normally, an operation ends at the end of a sector; however, if the operation ends before the end of the sector is reached, the End of Operation signal is delayed until completion of that sector.

Release Interrupt on End of Operation (0023)

This code removes the associated interrupt selection set up by the 0022 code. No interrupt indication of end of operation is sent until the condition is reselected.

Select Interrupt on Abnormal End of Operation (0024)

This code causes the interrupt line to be activated and the associated status bit set on the stopping of an operation due to any abnormal condition within the controller or selected storage unit.

The following conditions are considered abnormal:

- 1) An Address Error is detected.
- 2) Any attempt to write at a location which is in a Write Lockout state.
- 3) Occurrence of a Checkword Error (indication of an error in the data read from the selected storage unit).
- 4) Occurrence of a Lost Data error (data missed due to channel failure to maintain a fast enough transfer rate).
- 5) Any attempt to perform an operation on a defective track.

Release Interrupt on Abnormal End of Operation (0025)

This code removes the associated interrupt selection set up by the 0024 code. No interrupt indication of Abnormal End of Operation is sent until the condition is reselected.

Select Interrupt on Opposite Channel Release (0026)

This code causes an Interrupt signal to be sent and the associated status bit set whenever the opposite data channel (the channel presently maintaining a Reserved state of the controller) releases its reservation of the controller and storage units. If only one data channel is connected to the controller, this code is not applicable and should not be used.

NOTE

The interrupt is conditioned upon the dropping of the reserve. Therefore, a Master Clear causes the interrupt only if the data channel executing the Master Clear has the subsystem reserved.

Release Interrupt on Opposite Channel Release (0027)

This code removes the associated interrupt selection set up by the 0026 code. No interrupt indication of a release by the opposite channel is sent until the condition is reselected.

Select Interrupt on End of Seek (0030)

This code causes the interrupt line to be activated and the associated status bit set at the end of the Seek operation (in any storage unit) regardless of whether the seek was complete or incomplete.

Release Interrupt on End of Seek (0031)

This code removes the associated interrupt selection set up by the 0030 code. No interrupt indication of an End of Seek operation is sent until the condition is reselected.

Input/Output Codes

These codes define the conditions for the various data handling operations which cause the transfer of data between the data channel and/or the controller and the selected peripheral storage device. With the exception of the Checkword Verify, the codes all require initiation of an input or output operation in order to activate the subsystem. See Programming Considerations for timing diagrams of buffered I/O operations.

Read (0040)

This mode, in conjunction with an input operation causes the controller to initiate a Read operation from the selected storage unit at the address specified by the content of the controller Address register. The operation continues until halted by one of the conditions listed under Interrupt on End of Operation. When operating in End of Record mode, an EOR signal is transmitted to the data channel on detection of a record mark at the end of a data block.

Write (0041)

This mode, in conjunction with an output operation, causes the controller to initiate a Write operation to the selected storage unit at the address specified by the content of the controller Address register. The operation continues until halted by one of the conditions listed under the Interrupt on End of Operation. If an output operation terminates before the end of the current data block, the remainder of the block is automatically filled with

zeros. The checkword is always written at the end of the block. When operating in EOR mode, an EOR mark is recorded at the end of the last block written.

Search Compare (0042)

This mode, in conjunction with an output operation, causes the controller to initiate a Read operation from the selected storage unit at the address specified by the content of the controller Address register.

The output operation transmits data to the controller which is compared by bytes on a bit-by-bit basis with the data read from the storage unit. The compare is performed according to the previous settings of the mode select functions.

Upon occurrence of a miscompare (unsuccessful comparison), the No Compare status bit is set.

Masked Search Compare (0043)

This mode, in conjunction with an output operation, causes the controller to initiate a Read operation from the selected storage unit at the address specified by the content of the controller Address register.

The output operation transmits data to the controller which is compared by bytes on a bit-by-bit basis with the data read from the storage unit; however, if a byte in the output data contains all one's (7777_8) no comparison is made on the associated byte read. The compare operation is performed according to the previous settings of the Mode Select function.

Upon occurrence of a miscompare (unsuccessful comparison) the No Compare status bit is set.

Checkword Verify (0044)

This is the only operating mode which does not require a buffer. On receipt of this function code by the controller, the data within the current cylinder (or strip in the strip file) is read and checked for an illegal checkword. Operation commences at the present address position of the Read/Write heads and continues to the end of that cylinder (or strip in the strip file).

NOTE

When operating in End of Record mode, only one record is verified or if no record mark is present, the rest of the file/cell is verified.

Read Checkword (0045)

This operation, in conjunction with an input operation, causes the controller to initiate a Read operation from the selected storage unit at the address specified by the content of the controller Address register. This operation is identical to the 0040 Read function except that all checkword(s) read are returned to the data channel along with the data.

There is one checkword per data block in the disk file and disk drive units. There are six checkwords per data block in the strip file (see Checkword Location).

The operation continues until halted by one of the conditions listed under Interrupt on End of Operation.

Mode Select Codes

These codes select and specify the conditions under which the 0042 Search Compare function operates, and determines and identifies the conditions under which an end of operation occurs.

Magnitude Search (Record \leq Buffer) (0050)

This code modifies the Search Compare operation such that the comparison is satisfied if the data read (searched) is equal to or less than the output data.

The search is unsuccessful (no compare status bit sets) when the first (high order) unmasked output data bit is a "0" and the record bit is a "1".

Magnitude Search (Record \geq Buffer) (0051)

This code modifies the Search Compare operation such that the comparison is satisfied if the data read (searched) is equal to or greater than the output data.

The search is unsuccessful (no compare status bit sets) when the first (high order) unmasked output data bit is a "1" and the record bit is a "0".

Equality Search (Record=Buffer) (0052)

This code modifies the Search Compare operation such that the comparison is satisfied only if the data read (searched) is equal to the output data. Any MC operation automatically selects this mode of operation.

The search is unsuccessful (no compare status bit sets) when the first unmasked output data bit is different from the record bit read.

Buffer Mode (0053)

This code prepares the controller for a subsequent I/O operation wherein the end of operation is defined as the word count of the I/O operation. (Refer to Buffer Restrictions under Programming Considerations).

End of Record Mode (0054)

This code prepares the controller for a subsequent I/O operation wherein the end of operation is defined as the limit of the record as follows:

- Write - a record mark is recorded at the end of the block in which the output operation ended. The original output operation may be from less than a single block to an entire file (cell) in length.
- Read - an End of Record signal is sent to the data channel each time the record mark is detected.

Any MC automatically selects this mode of operation.

STATUS CODES

In order for the computer to determine the state of the controller and storage units, a 12-bit status response is available to the data channel. The computer initiates a Copy Status instruction and samples the status response on the lines from the controller. The computer may sample a status response anytime it is connected, or after a connect attempt is rejected if the controller and/or peripheral units are under control or reservation by a different data channel. The status response may be a combination of any of the available response bits.

The status response bits (Table C-2) indicate the state of the controller and storage unit to which the data channel is connected or last attempted to connect. A "1" in the bit position

indicates the condition is present (or has occurred); a "0" indicates the condition is not present (or has not occurred). It should be noted that an interrupt must previously have been selected or the associated interrupt status bit will be a "0" even though a condition that would normally set the interrupt has occurred (e. g. , a copy status does not indicate that an abnormal end of operation has occurred unless the Abnormal End of Operation Interrupt is selected). If the Abnormal End of Operation Interrupt is selected, the operation ends, the Interrupt Error status bits are set and the interrupt is sent to the data channel immediately upon occurrence of the error condition. However, if the Abnormal End of Operation Interrupt is not selected, the error status bits are set immediately upon occurrence of the error condition even though the operation may not end until the buffer is completed.

Ready (XXXI)-Bit 0

The presence of this bit indicates the unit last connected is in an operable condition and ready for use. A storage unit is considered Ready when it is available and ready to operate. The unit becomes Not Ready (and unavailable) for the following conditions:

Disk File and Disk Drive Units

- 1) Disk Pack not loaded (applicable to disk drive unit only)
- 2) R/W heads not landed
- 3) Disk motor not up to speed
- 4) File or disk drive Unsafe condition from selected unit (refer to Unsafe Conditions)
- 5) No such unit
- 6) Wrong unit type designation

Strip File

- 1) ENABLE/DISABLE (Running Time meter) switch in the Disable position
- 2) Unit is in Customer Engineering mode (off-line)
- 3) Manual intervention
- 4) File Unsafe condition (refer to Unsafe Conditions)
- 5) No such unit
- 6) Wrong unit type designation

The latter two conditions (5 and 6) on all unit types cause a Reject on Connect.

Any 1X, 4X, or 5X function code is rejected when the controller is Not Ready; other function codes are accepted even if the controller is not Ready. If a unit becomes Not Ready during an operation, the operation ceases immediately and (if selected) the Abnormal End of Operation interrupt is sent to the data channel.

Busy (XXX2)-Bit 1

The presence of this bit indicates the controller and/or peripheral unit specified by Connect code are currently performing an operation and are unable to initiate any new action at this time. The bit becomes a "0" at the end of operation.

The Busy status normally follows the Channel Busy signal; however, the Busy status remains until the checkword has been written or read, the Address register updated, and in the case of the strip file until the Adaptor Busy signal drops. (This is the end of operation on a Read or Write function and, if selected, the End of Operation interrupt occurs at this time.) Any abnormal condition which causes an end of operation to occur causes the Busy status to drop.

In the case of a Checkword Search even though no buffer is initiated, the subsystem is busy until the search is finished.

A storage unit is Busy following a Seek initiation until the seek is completed; however, the controller is available for operation to a different unit as soon as the Positioner Ready signal drops.

Abnormal/Unavailable (XXX4)-Bit 2

When the system is connected and reserved, the presence of this bit indicates that an abnormal condition exists in the controller or storage unit and assigns a different meaning to the status bits XX1X through X1XX and 4XXX.

If a connect attempt is rejected, the presence of this bit indicates that the storage unit requested by the Connect code was unavailable.

Two types of unavailability exist, permanent and temporary.

Permanent Unavailability: When a unit is unavailable and Not Ready it is considered to be permanently unavailable (manual intervention is necessary to remove the cause of unavailability).

Temporary Unavailability: When a unit is unavailable and Busy, it is considered to be temporarily unavailable, but becomes available as soon as it becomes Not Busy.

On Sector (XX10)-Bits 3, $\bar{2}$

Disk File and Disk Storage Drive Units

The On Sector status bit comes up one sector prior to the addressed sector with or after the Positioner Ready status. This allows the computer a one-sector time slot in which to initiate an operation on the addressed sector. If no operation is initiated within the one-sector time slot (1 ms), the On Sector status bit drops and comes up again one revolution later.

Strip File

When operating with the Strip File unit there is only one sector per track; therefore, the On Sector status bit comes up at the index (8 ms before the sector starts) and stays up until the unit is operated on.

See Programming Considerations for timing diagrams showing the relationship between the On Sector and Positioner Ready signals.

Address Error (XX14)-Bit 3, 2

The presence of this code indicates that an Address Error has been detected due to one of the following conditions:

- 1) The Address register contains an illegal address.
- 2) The content of the Address register does not compare with the address being read from the storage unit.
- 3) The controller has been requested to operate beyond the storage unit address limits.
- 4) The Seek operation initiated by the Load Address was incomplete.
- 5) Defective Track bit is present.
- 6) Checkword error occurs during address verification.

If an error occurs during an operation, the operation ends immediately, and if selected an Abnormal End of Operation Interrupt is transmitted. A new Load Address function should be performed before any new I/O is attempted.

No Compare (XX20)-Bits 4, $\bar{2}$

The presence of this status code indicates that a miscomparison was detected during the preceding Search Compare operation.

Lost Data (XX24)-Bits 4, 2

The presence of this status code indicates that data has been lost due to the data channel (computer) delay. Specifically, in the case of an output operation, no data was ready when the storage unit was ready to write, or in the case of an input operation, the data channel had not yet accepted the last byte read when the storage unit had another byte ready.

Upon detection of Lost Data, operation ends immediately if the Abnormal EOP Interrupt is selected and the associated status bits set. If the Abnormal End of Operation Interrupt is not selected, operation continues in a normal manner; however, the Lost Data status bit sets.

End of Record (XX40)-Bits 5, $\bar{2}$

The presence of this bit indicates that an End of Record bit has been detected at the end of the last sector when operating in End of Record mode. If the subsystem is not operating in the End of Record mode this bit is a "0" even if an End of Record bit is present at the end of a sector.

Checksum Error (XX44)-Bits 5, 2

The presence of this status code indicates that an incorrect checksum has been detected during a Read, Search Compare, or Checksum Verify operation.

Write Lockout on Read (XIX0)-Bits 6, $\bar{2}$

On an input (Read) operation it is permissible to operate in a Write Protected area and other than setting this status bit, operation proceeds in a normal manner.

Write Lockout on Write (X2X4)-Bits 6, 2

For an output (Write) operation this is an abnormal condition, and if the Abnormal End of Operation Interrupt is selected, operation ends immediately upon initiation of the operation and the Abnormal End of Operation Interrupt sets.

If the Abnormal End of Operation Interrupt is not selected, the output data is accepted by the controller; however, the data accepted is ignored and no data is written on the selected storage unit.

Positioner Ready (X2XX)-Bit 7

The presence of this bit indicates that a Positioner Ready signal has been received from the selected storage unit. In the disk file and disk drive units this signal comes up as soon as the positioner is settled on the cylinder. The Positioner Ready must come up before On Sector can come up.

The Positioner Ready status stays up until a new Load Address operation is initiated. If selected, an End of Operation interrupt sets when the Positioner Ready is received.

See Programming Considerations for timing diagrams showing the relationship between the On Sector and Positioner Ready signals.

End of Operation Interrupt * (X4XX)-Bit 8

The presence of this bit indicates the interrupt was caused by an End of Operation.

Abnormal End of Operation Interrupt * (1XXX)-Bit 9

The presence of this bit indicates the interrupt was caused by an Abnormal End of Operation.

Seek Interrupt (2XXX)-Bit 10

The presence of this bit indicates the interrupt was caused by the end of a Seek operation (in any storage unit) regardless of whether the Seek was complete or incomplete.

* For an explanation of End of Operation and an Abnormal End of Operation (see Interrupt codes 0022 and 0024).

Reserved (4XX0)-Bits 11, $\bar{2}$

The presence of this status code indicates the last Connect attempted to the subsystem was rejected because the subsystem was reserved by the opposite data channel.

Defective Track (4XX4)-Bits 11, 2

The presence of this status code indicates a Defective Track bit has been detected at the address referenced by the content of the controller Address register. Once a track is marked defective any I/O operation attempted on that track hangs up and an Address Error occurs (see Abnormal EOP interrupt). (The Defective Track bit is written manually into the header via the maintenance panel.)

SYSTEM ERRORS AND PERFORMANCE

The controller is designed to recognize the following error conditions:

- Transmission Parity Error
- Lost Data
- Write Lockout
- Checkword Error
- Address Error
- Defective Track

With the exception of the Transmission Parity Error the presence of the errors may be detected through the use of interrupts and/or a status response.

Other internal error conditions (see Unsafe Conditions) from the selected storage unit cause the subsystem to go to the Not Ready state. (The Not Ready condition may be detected via the status response.)

Transmission Parity Error

The Transmission (XMSN) Parity circuits examine each byte transmitted to the controller from the data channel, generate a new parity bit for that byte, and compare the parity bit generated with the parity bit accompanying the byte. If the bits do not agree, the PARITY ERROR indicator lights. Transmission of the error indication to the data channel is dependent upon the code or data causing the error as follows:

XMSN Parity Error on Connect: If the error is detected on a Connect code, the controller will not connect, and if connected will disconnect (including its status lines). The transmission PARITY ERROR indicator lights, but no Reply, Reject, or Transmission Parity Error signals are sent to the data channel.

XMSN Parity Error on Function: If an error occurs on the function code, the Transmission Parity Error signal is sent to the data channel and the error indicator lights, however, the function code is ignored by the controller. (No Reply or Reject is sent.)

XMSN Parity Error on Data Transfer: If an error is detected on a data byte received from the data channel, the XMSN Parity Error signal is sent and the error indicator lights. The controller returns a Reply and uses the data in the normal manner.

Lost Data

A Lost Data error occurs when the data channel does not transmit or receive data at the fixed rate required by the subsystem. This condition can occur when the data channel serving the mass storage subsystem must compete with several other devices for access to the computer storage. Specifically, an error occurs when the computer does not have data ready to be written when the storage unit is ready to write (output operation), or the computer has not yet accepted the data read when the storage unit has another byte ready (input operation).

Write Lockout

To prevent accidental destruction of data, each sector address is equipped with a Write Lockout bit. Setting the bit to a "1" prevents any computer operation from writing in that sector. Note, however the smallest segment of storage area that can be locked out is a track.

Attempting to write in a sector or track that has the Write Lockout bit set generates a fault condition (Write Lockout Error). The Write operation is then performed in a normal manner except that no writing or erasing takes place (the Write amplifier is disabled by the lockout). If selected, the Abnormal End of Operation Interrupt is set and operation ends immediately.

Reading from a sector/track that has the Write Lockout bit set is accomplished in a normal manner (this is not considered a fault condition) even though the Write Lockout status bit sets. No Abnormal End of Operation Interrupt is generated even though it is selected (see WRITE LOCKOUT switch under Switches and Indicators).

Checksum Error

During Write operations, a cyclic encoder in the controller generates a 12-bit check character referred to as a checksum. This checksum is written at the end of each sector (in the disk files and disk drive units); six checksums are written per sector (track) in the Strip File.

During a Read/Search operation a new checksum is generated from the data read, and compared against the checksum previously written. If the two do not agree an error has occurred in writing, reading, or transferring of data between the controller and selected storage unit and a Checksum Error is generated.

On detection of a Checksum Error the associated status bit sets, and if selected an Abnormal End of Operation interrupt is generated. If the Abnormal End of Operation Interrupt is not selected, the Checksum Error status bit sets; however, operation continues in a normal manner.

NOTE

If a Checksum Error is detected in an Address Header, an Address Error is generated and operation ceases immediately. (See Address Error below.)

Address Error

An address operation consists of two main phases:

- 1) A Seek operation wherein, upon completion of an output operation following a Load Address function, the R/W heads are positioned to the addressed cylinder, and
- 2) A Header Verification sequence wherein, upon initiation of an operation, the address header is read and verified for the addressed sector.

An Address Error can occur in either the previously initiated Seek operation or during the Header Verification sequence. Therefore, since initiation of an operation (and Header Verification) may occur anytime and is semi-unrelated to any preceding Seek operation,

an Address Error can occur at two distinct and mutually independent times (upon detection of a Seek Error, or on detection of a Header Verification Error).

Seek Error: An Address Error occurs during a Seek operation if either of the following conditions are detected:

- a) The controller Address register contains an illegal address. (The controller is being requested to operate beyond the address limitations of the selected storage unit.)
- b) The Seek operation initiated by the preceding Load Address function and buffer is incomplete (as indicated by a Seek Error signal for the selected unit).

Header Verification Error: An Address Error occurs during a Header Verification sequence if any of the following are detected:

- a) A Checkword Error is detected in an Address Header.
- b) The content of the controller Address register does not compare with the address being read from the selected storage unit (i. e. , incorrect address being read from storage unit or the storage unit is unable to locate the desired address).
- c) A defective track is addressed.

On detection of an Address Error the associated status bit sets, and if selected the Abnormal End of Operation Interrupt is generated on initiation of an operation. (If the Abnormal End of Operation Interrupt is not selected, the channel hangs up on initiation of the operation.)

Defective Track

In order to prevent reading or writing in a track which contains a defective (faulty) recording medium, a Defective Track bit is contained in each sector of the failing track. The track is defective when this bit is a "0".

On detection of a defective track, the associated status and Address Error bits set, and if selected the Abnormal End of Operation Interrupt is generated upon initiation of an operation (see DEFECTIVE TRACK switch under Switches and Indicators).

ADDRESSING

After transmitting the Connect code, the computer may transmit a Load Address Function code. If the operation is to start or continue at the address location presently held in the controller Address register, the Select and I/O operating mode codes are set up on completion of the connect. The address currently held in the register is the one in which the next I/O operation will take place. This address is automatically incremented after each sector is written or read from the selected storage unit unless:

- a) The equipment becomes Not Ready during an operation,
- b) The Abnormal End of Operation Interrupt is selected and any abnormal condition occurs,
- c) An Address Error occurs.

This process takes place throughout the entire file, pack, or cell from the starting address up to and including the last available address. If the I/O operation attempts to cause incrementation to continue beyond the last available address, an Address Error occurs, and if selected, the Abnormal End of Operation Interrupt is generated. Once the last available address has been utilized, the Address register must be reset. This may be done by loading a specific address (via the Load Address function) or by executing a Master Clear or a Clear function instruction. In the latter two cases, the register is set to zero. If, however, a new address is necessary for the next operation, the Load Address code must be sent to the controller.

Load Address

On initiation of an output operation following receipt of the Load Address function code, the controller commences loading 12-bit bytes from the data channel. These bytes form a 24-bit address word which is automatically loaded into the Address register by the controller. The first byte of the address is loaded into the upper portion of the register; the second byte is loaded into the lower portion of the register. The output from the computer may consist of several words. The controller continues to load the bytes into the Address register as previously described until the end of the operation. Thus, the last two bytes transferred comprise the address remaining in the Address register.

NOTE

3000 Series computers disassemble words
upper byte first.

Address Format

The address format structure varies within the various peripheral types (see Figures C-14, C-15, and C-16). The byte address specifies (in the case of the disk file and disk drive units) the cylinder and the track and sector within that cylinder at which the next operation takes place.

From a programming viewpoint the lower address portion may be considered to specify the addresses of all sectors in a single cylinder/strip. Specifically in the disk file and disk drive the lower order bits of the lower address specify one of the sectors in a track; the upper order bits of the lower address specify one of the tracks in the cylinder.

During multiple-recorded transfers (operations of more than one sector in length) the address is automatically augmented to select the next sequential sector location. This process takes place throughout the entire file, pack, or cell up to and including (but not beyond) the last address (operation is not end-around within a file, pack, or data cell).

Disk File:

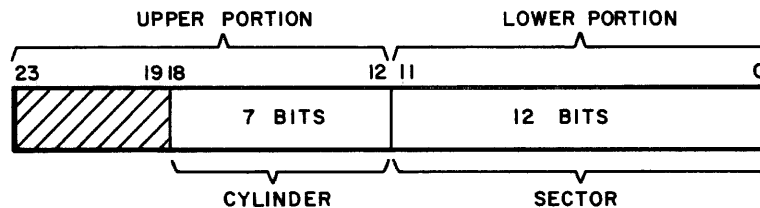

Figure C-14. Disk File Address Format

Bits 0-11 specify one of 4096_{10} sectors in a cylinder (address $0-7777_8$). Bits 0-4 specify one of 32_{10} sectors per track (addresses $0-37_8$); bits 5-11 specify one of 128_{10} tracks per cylinder (addresses $0-177_8$).

Bits 12-18 specify one of 128_{10} cylinders per access (unit) (addresses $0-177_8$). Addresses above 177_8 are illegal and cause an address error to be generated.

Disk Storage Drive:

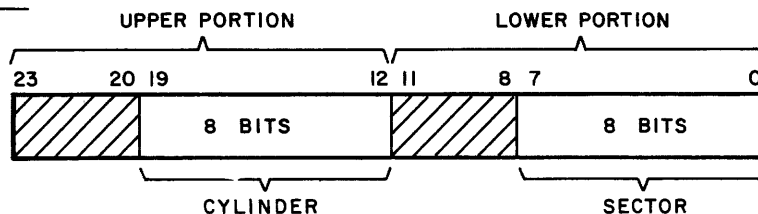

Figure C-15. Disk Storage Drive Address Format

Bits 0-7 specify one of 160_{10} sectors per cylinder (address 0- 237_8). Addresses above 237_8 are illegal and cause an address error to be generated. Specifically bits 0-3 specify one of 16_{10} sectors per track (addresses 0- 17_8); bits 4-7 specify one of 10_{10} tracks per cylinder (addresses 0- 11_8).

Bits 12-19 specify one of 100_{10} cylinders (addresses 0- 143_8) in the 853 Disk Storage Drive units or one of 202_{10} cylinders (addresses 0- 311_8) in the 854 Disk Storage Drive units. Addresses above 143_8 in the 853, or above 311_8 in the 854 are illegal and cause an address error to be generated.

Strip File:

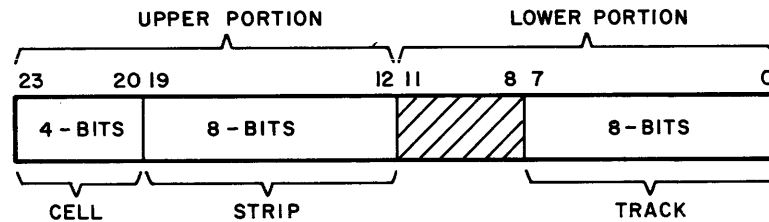

Figure C-16. Strip File Address Format

Bits 0-7 specify one of 100_{10} tracks (sectors) per strip (addresses 0- 143_8). Addresses above 143_8 are illegal and cause an address error to be generated.

Bits 12-19 specify one of 200_{10} strips per cell (addresses 0- 307_8). Addresses above 307_8 are illegal and cause an address error to be generated.

Bits 20-27 specify one of 10 cells per array (unit), (addresses 0- 11_8). Addresses above 11_8 are illegal and cause an address error to be generated.

The Strip File addresses for track/cylinder (lower portion) and subcell/strip (upper portion) are continuous binary addresses. Table C-3 indicates decimal to octal conversion of the addresses used by the strip file.

TABLE C-3. STRIP FILE ADDRESS CONVERSION CHARTS

TRACK (head selections)		LOWER ADDRESSES																			
		0	1	2	3	4	5	6	7	8	9	10	11	12	13	14	15	16	17	18	19
CYLINDER (head position)	0	0	1	2	3	4	5	6	7	10	11	12	13	14	15	16	17	20	21	22	23
	1	24	25	26	27	30	31	32	33	34	35	36	37	40	41	42	43	44	45	46	47
	2	50	51	52	53	54	55	56	57	60	61	62	63	64	65	66	67	70	71	72	73
	3	74	75	76	77	100	101	102	103	104	105	106	107	110	111	112	113	114	115	116	117
	4	120	121	122	123	124	125	126	127	130	131	132	133	134	135	136	137	140	141	142	143

SUBCELL		UPPER ADDRESSES																			
		0	1	2	3	4	5	6	7	8	9	10	11	12	13	14	15	16	17	18	19
STRIP	0	0	12	24	36	50	62	74	106	120	132	144	156	170	202	214	226	240	252	264	276
	1	1	13	25	37	51	63	75	107	121	133	145	157	171	203	215	227	241	253	265	277
	2	2	14	26	40	52	64	76	110	122	134	146	160	172	204	216	230	242	254	266	300
	3	3	15	27	41	53	65	77	111	123	135	147	161	173	205	217	231	243	255	267	301
	4	4	16	30	42	54	66	100	112	124	136	150	162	174	206	220	232	244	256	270	302
	5	5	17	31	43	55	67	101	113	125	137	151	163	175	207	221	233	245	257	271	303
	6	6	20	32	44	56	70	102	114	126	140	152	164	176	210	222	234	246	260	272	304
	7	7	21	33	45	57	71	103	115	127	141	153	165	177	211	223	235	247	261	273	305
	8	10	22	34	46	60	72	104	116	130	142	154	166	200	212	224	236	250	262	274	306
	9	11	23	35	47	61	73	105	117	131	143	155	167	201	213	225	237	251	263	275	307

PROGRAMMING CONSIDERATIONS

The following information concerns problems that may arise in programming mass storage subsystems. Most of the procedures are common to all computers and storage devices; those that are unique to a particular computer or unit are so stated.

CONNECT

Device type codes other than XX1X, XX2X, and XX3X, are illegal and cause the Connect to be rejected. The Unavailable and Not Ready status bits set.

SIMULTANEOUS CONNECT

If the two data channels attached to the same controller simultaneously attempt to connect to the controller, neither channel is given preference. The controller will connect to the data channel recognized first.

Initiation of the operation need not take place immediately after the connect is made; once the connect is made, the channel has the controller and subsystem reserved until specifically released by that channel.

MODE RESTRICTIONS

Operations which are inconsistent with the mode selected cause the computer to hang up (i. e., initiation of an output (write) when Read mode is selected).

MASTER CLEAR, RELEASE AND DISCONNECT

A manual or program (channel) MC, Clear function, or Restore function cause the Address register to be cleared to zero. A Release and Disconnect has no effect on the content of the Address register. The MC, Clear function, and Release and Disconnect remove all interrupt selections except the interrupt on opposite channel release. A MC automatically selects End of Record and Magnitude Search (record = buffer) mode.

Strip File

If the strip file is busy when a MC is initiated, the MC may cause the file to go inoperative and require manual intervention to remove the inoperative condition.

Disk Unit

Any MC to a unit which is busy with a Write operation causes the operation to cease immediately; however, the previously recorded data and checkword in the remainder of the sector are unaltered (and now useless). Therefore a subsequent Read operation causes a checkword error to be generated from the inconsistent data recorded in the sector.

Any MC to a disk unit busy with a Read operation causes operation to cease immediately, but has no other affect on the present or subsequent operations.

RESTORE (STRIP FILE)

When the equipment is disconnected (strip file released), the strip is automatically restored if the same strip is not readdressed (unit reconnected) within 16 revolutions of the drum (approximately 800 ms).

INTERRUPTS

An Interrupt signal may be dropped by any MC, Clear function, Release and Disconnect function, or by any new function code including re-selecting the same Interrupt selection.

Only the Interrupt on Opposite Channel Release interrupt selection remains when a Release and Disconnect is performed. All other interrupt selections are removed whenever a MC, Clear function, or Release and Disconnect are performed.

NOTE

The Interrupt on Opposite Channel Release can be cleared by a MC or Clear function only when the opposite channel is Not Reserved (i. e., the Channel B Release Interrupt selection can be cleared only if Channel B is Not Reserved.)

Any interrupt selection may be removed by its associated Release Interrupt code.

A data channel which has the subsystem reserved receives all interrupts selected. The channel not in control (reservation) of the subsystem can be interrupted only by a previously selected Interrupt on Opposite Channel Release. All other interrupts from the controller to the data channel not in control are inhibited even though the interrupt is selected.

ABNORMAL EOP INTERRUPT

The Abnormal End of Operation interrupt should always be used when performing any I/O operations (4X codes) other than the Load and Return Address functions. If the interrupt is not used and either an Address Error or Not Ready condition occur, the channel hangs up in a busy condition. With the interrupt selected an Interrupt Lockout Override is sent back to the data channel to allow the program (via a Clear Channel instruction) to recover from the hung condition.

SEEK/SECTOR VERIFICATION

When any I/O code (4X) operation is initiated an automatic Seek is performed to the address specified by the content of the controller Address register. (Normally no positioner or strip loading movement takes place since this Seek operation would have been performed subsequent to the last Load Address operation.) The new (automatic) header verification takes place at the sector following the one in which the last operation ended unless the new I/O is initiated in a different unit than the one last referenced*. In the latter case if the positioner is not in the proper cylinder, both a Seek and Header Verify sequence are automatically initiated.

OVERLAP SEEK

Overlap Seek capability is incorporated within the units and can be performed on any storage unit in the subsystem as follows:

- 1) Select unit, select Seek Interrupt, and initiate a Seek operation (by performing a Load Address function).

* When any I/O is in progress (or ends) the controller automatically updates the address registers at the end of each sector except when an Address Error is detected or if the Abnormal EOP Interrupt is selected and an abnormal condition occurs.

- 2) Repeat step 1) for other desired storage units.
- 3) On detection of an interrupt*, search the selected storage units for an On Sector status bit to determine which unit is ready for operation.
- 4) Initiate and perform I/O operation.
- 5) Continue from step 3).

The On Sector status is returned from a storage unit in which a Seek operation (Load Address operation) is completed (positioner ready) until a Read/Write (or MC) is performed on that unit. Therefore if several overlapped seeks are initiated, but with no read/write operations, a Seek Interrupt is generated each time the Seek interrupt is selected until all previously addressed units have had a read/write (or MC) operation performed on them.

NOTE

The Seek interrupt is generated from a line common to all units such that an interrupt can be generated by a unit in which a seek was initiated even though the controller is no longer connected to that particular storage device.

1X AND 4X FUNCTION CODES

When preparing the subsystem for operation via the issuance of the various function codes, the 1X (address) or 4X (I/O codes) must be issued last or they will be cleared out by the next function code issued. With the exception of the 0044, Checkword Verify code, the 1X and 4X function codes are designed to be followed by a buffered operation.

RECORDS

Records consist of full sectors only. If an output from the data channel consists of less than a full sector when operating in End of Record Mode, the remainder of the sector is automatically filled with zeros and the record mark is written at the end of the sector. It is possible to count and locate record marks in the various storage units by performing a Checkword Verify in End of Record mode, and then performing a Return Address. The sector address returned is one greater than the address in which the record mark was detected. The difference between the starting and ending addresses is one greater than the number of sectors in the record.

* An alternate method is to omit the interrupt and immediately (on completion of seek initiations) commence a continuous search of the On Sector status bits.

STRIP FILE

The following considerations are peculiar to the strip file only.

Checkword Location

Six checkwords are written in each sector (track) in the strip file. These checkwords are located in the following byte-positions within each track:

106	874
362	1130
618	1386 (last byte of the track)

Restore

The unit select must be dropped (either by releasing, clearing, or disconnecting) or a Restore function performed in order to prevent excessive strip wear. If a select is dropped for more than 0.8 μ sec an automatic restore is initiated in the file.

Test Cell

A special customer engineering test cell is provided to aid in strip file maintenance procedures. It becomes program responsibility to prevent damage (writing) of the information within this cell when the test cell is in the array.

Cell Replacement

Individual cells can be installed in any of the 10 positions of the array. When installing a cell, care must be taken to ascertain that it is in the proper position. The cell accessed by the previous operation is under the access station and not at the replacement station (see Figure C-17).

DISK STORAGE DRIVES

The following considerations apply only to the disk drive units.

Compatibility exists between the 1738 Disk Drive Subsystem and the 3234 Mass Storage Subsystem; however, the compatibility is limited to those features necessary for data recoverability. To accomplish this, all record gaps are of the same size, the address

headers are recognizable by both subsystems, and the data areas contain the same number of bits. Both subsystems use a 12-bit cyclic code (checkword) for error detection.

The following differences exist in the two subsystems:

1) Data transfer:

3234	12-bit byte
1738	16-bit byte

Computer formatting is necessary for conversion of word size between the two systems.

- 2) The 3234 subsystem utilizes a Write Lockout bit in the address header (see Write Lockout); this bit is not used or recognized by the 1738 subsystem.
- 3) The 3234 subsystem has an End of Record mode available; the 1738 subsystem does not use or recognize the EOR bit.

UNSAFE CONDITIONS

The presence of an Unsafe condition indicates the selected storage unit has one or more of the following fault conditions and causes the controller to become Not Ready:

- 1) More than one R/W head selected
- 2) Both the Read and Write Controls set
- 3) Erase and write driver on (Strip File only)
- 4) Both Write drives on (Strip File only)
- 5) Read or Write on and Not Ready set
- 6) Read and erase drivers both on
- 7) Write driver on and erase driver off (Disk File and Disk Drive only)

SECTOR TIMING

Disk File and Disk Drive Units

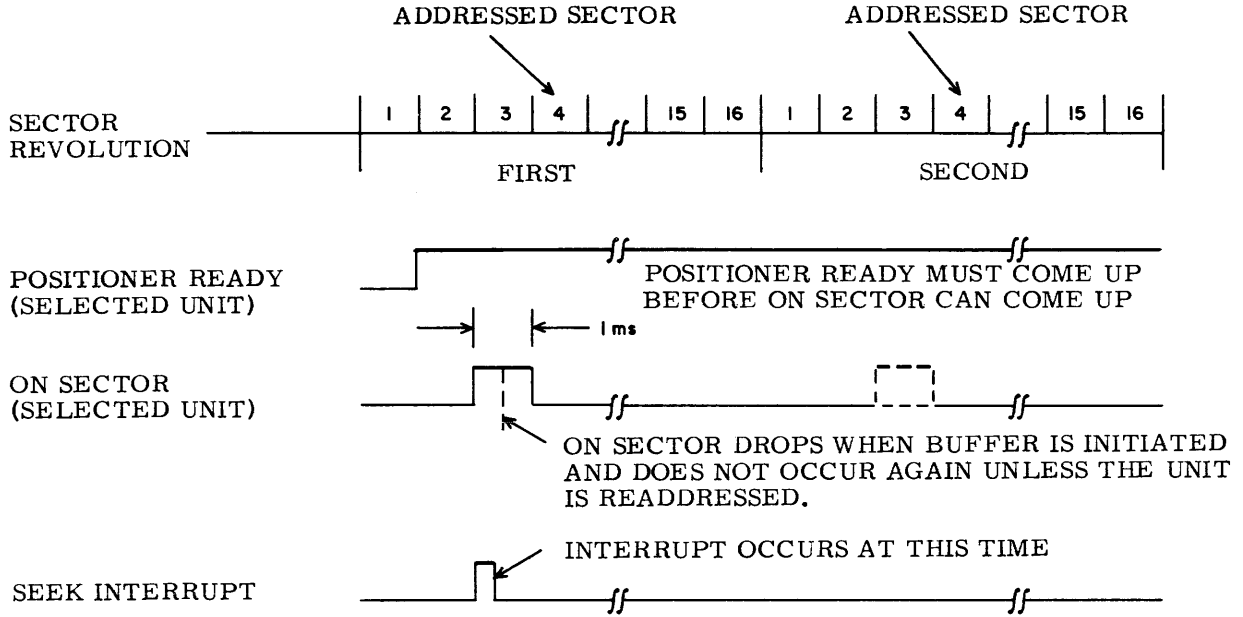

Strip File

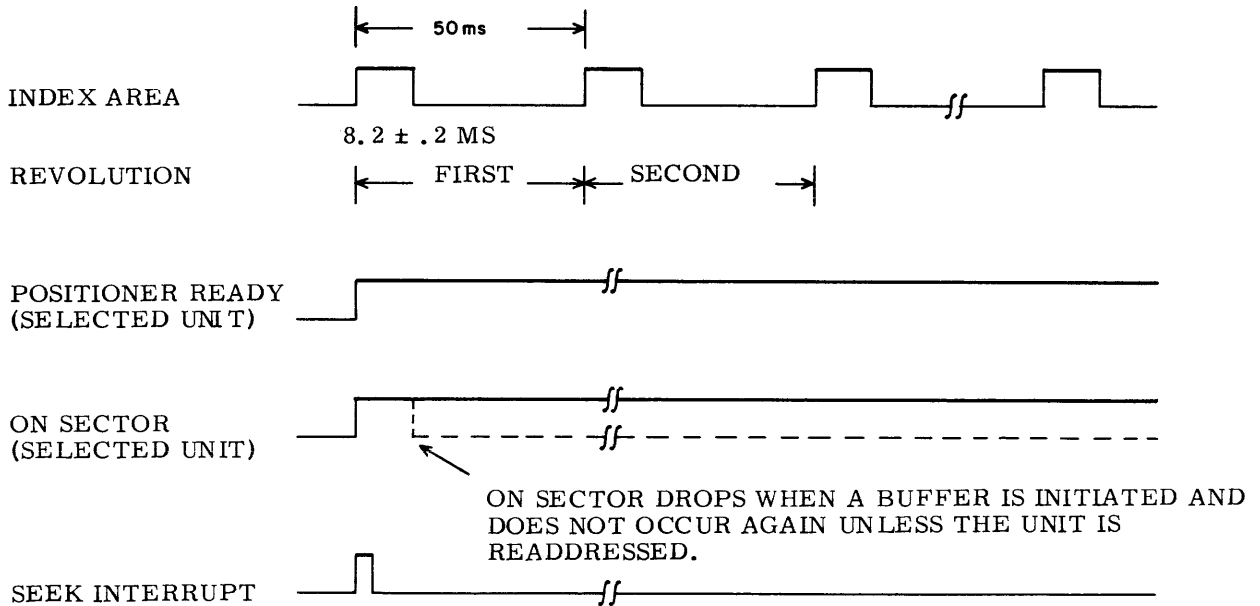

BUFFER TIMING

Input

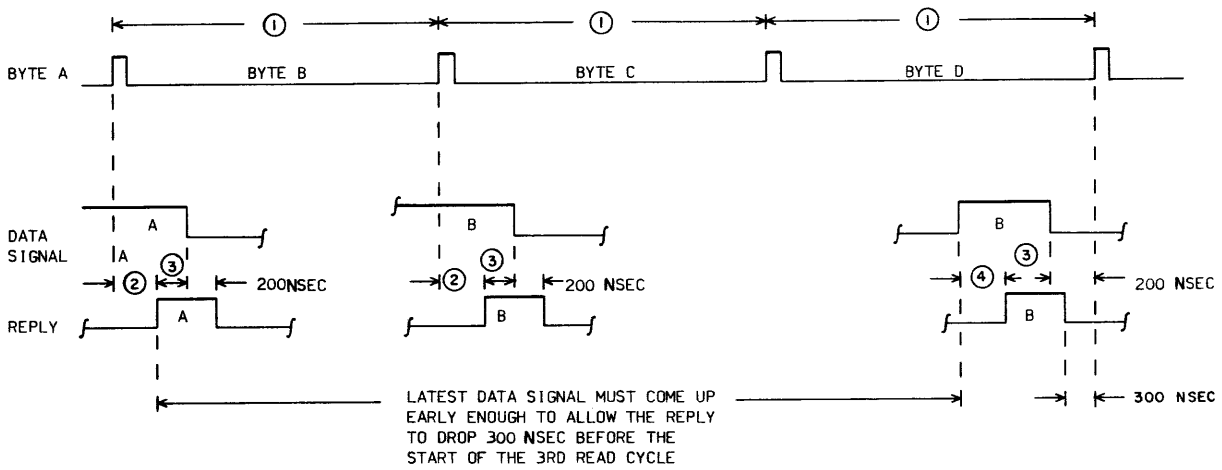

ALL TIMES ARE MEASURED AT THE CONTROLLER INTERFACE

- ① DISK FILE 10.2 μ SEC
DISK DRIVE 9.6 μ SEC
STRIP FILE 27.4 μ SEC
- ② LATEST REPLY, 700 NSEC IF BUFFER REGISTER IS EMPTY
- ③ CABLE DELAY AND TURN AROUND TIME
- ④ EARLIEST REPLY, 340 NSEC IF BUFFER REGISTER IS FULL

Output

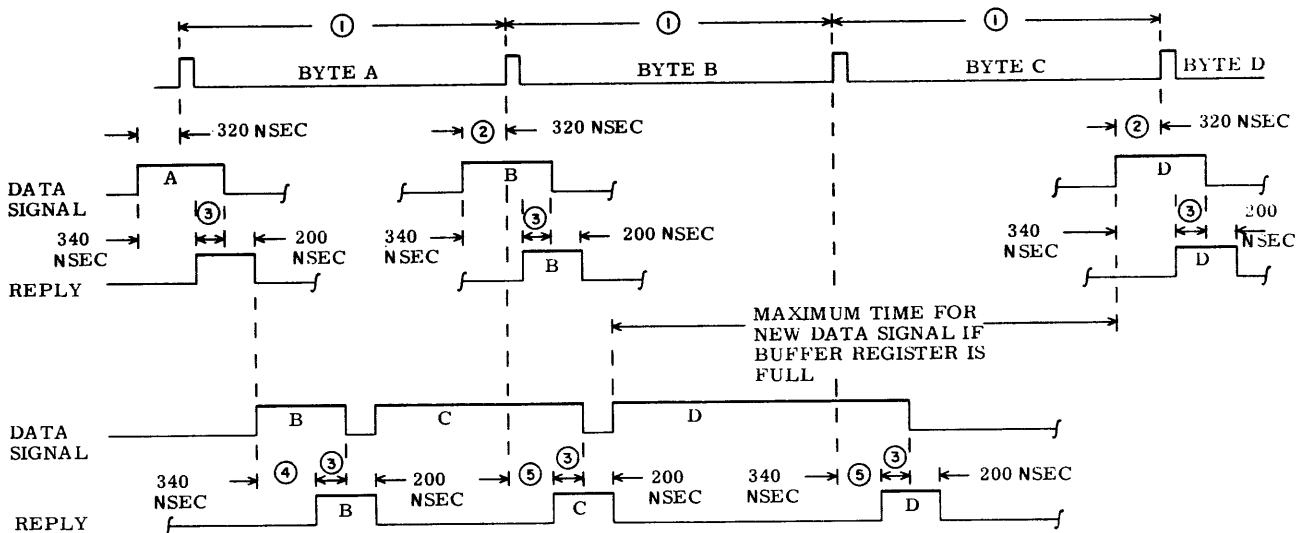

ALL TIMES ARE MEASURED AT THE CONTROLLER INTERFACE

- ① DISK FILE 10.2 μ SEC
DISK DRIVE 9.6 μ SEC
STRIP FILE 27.4 μ SEC
- ② IF BUFFER REGISTER IS EMPTY DATA SIGNAL MUST COME UP 320 NSEC BEFORE ITS ASSOCIATED WRITE CYCLE
- ③ CABLE DELAY AND TURN AROUND TIME
- ④ EARLIEST REPLY TO A DATA SIGNAL. 340 NSEC IF BUFFER REGISTER IS EMPTY.
- ⑤ LATEST REPLY TO A DATA SIGNAL, 500 NSEC FROM START OF NEXT WRITE CYCLE IF BUFFER REGISTER IS FULL

MANUAL OPERATIONS

Operation of the mass storage subsystem is under program control from the computer through the use of the Connect and function codes. Initial manual starting procedures include turning power on to the equipments, selecting the various switch settings, and loading a disk pack or data cell into the associated unit (if none are presently loaded). Disk packs and data cells must have headers recorded before they can be used for programmed operation.

POWER SEQUENCE

Following is the procedure to bring the subsystem up from a dead start (no power applied to the storage units or controller):

- 1) Turn on the main power circuit breaker in the 3234 (CB1 located on the front of the power panel).

The disk drive units and strip file automatically enter a Power On sequence. Each disk drive unit requires approximately 30 seconds to come up to speed and land the R/W heads. In a multiple unit system, each succeeding disk drive motor is automatically sequenced. The sequencing overlaps and a full complement of drive units should be up to speed in approximately 1 minute. The last disk drive (or 3234 if no disk drives are in the subsystem) initiates the Power On sequence in the strip files. A strip file requires approximately 10 to 15 seconds to become ready, and sequence the next unit; however, the Power On sequencing does not overlap and each file begins only upon completion of the previous file becoming ready. As soon as the disk drive and strip file units become operable (R/W heads landed), and the READY indicator (located in the Unit Designation indicator in the disk drives) lights, operation for both the disk drives and strip files may begin; however, a 15 minute warm-up period is recommended when commencing from a cold start.

- 2) Normally the disk file and associated hydraulic unit should have all switches in the proper position and only step 7) should be necessary to activate the units:

NOTE

Pressing the normal STOP switch requires a 20 second delay before shutdown. Pressing EMERGENCY OFF shuts down the system instantly.

CAUTION

Except in emergencies the blowers should remain on at all times to prevent dirt accumulation on the disk surfaces.

If the units must be started from a completely shut down position, the following steps should be performed:

- 1) Open front doors on the disk file and hydraulic unit plus the right side door on the disk file.
- 2) Place all front panel circuit breakers of both units to the ON position.
- 3) Set both Positioner switches to the NORMAL position.
- 4) Set all Manual/Automatic switches to the AUTOMATIC position.
- 5) Set FILE OPERATION switch to the AUTOMATIC position.
- 6) Set main circuit breaker (located below power distribution panel) to the ON position.
- 7) Press START and observe START indicator light. The following indicators light temporarily: LOW FILE TEMP, STACK RPM 0, STACK RPM 1, and dc voltages.

The disk file requires approximately 3 minutes to come up to operating speed; the hydraulic unit requires approximately 15 minutes (on water cooled unit).

LOADING AND UNLOADING PROCEDURES

The storage medium of the disk file units cannot be changed. To load or change the storage medium in the disk storage drive and strip file units the procedures listed should be followed:

Disk Storage Drive

- 1) If the unit is operating, turn power OFF by pressing the START switch located on the front of the disk drive unit. Wait for the spindle to stop rotating.
- 2) Lift the disk drive unit cover upward as far as possible to provide maximum loading clearance.
- 3) Load or unload the pack as follows:

Loading

Place the pack on the spindle and turn the cover handle clockwise to a full stop position. The pack should now be tight on the spindle and the protective cover lifts off easily.

Unloading

Engage the protective cover over the disk pack and rotate the cover three times in a counterclockwise direction. The pack releases from the spindle and can be lifted from the drive unit.

- 4) Close the disk drive unit cover and press the START switch on the front of the drive unit. This causes the unit to perform an initial Seek operation which positions and loads the R/W heads and brings the unit to the Ready state. (Operation cannot commence until this step is performed.)

Strip File

To facilitate a cell replacement, five operating aids are provided (Figures C-17 and C-18):

- 1) An entry door which permits access to the cell array. An interlock in the door molding prevents any machine motion while the door is open.
- 2) The cell location indicator which identifies (by number) the cell located in the replacement position. It also identifies the cell presently positioned at the access station.
- 3) SPINDLE RELEASE lever which allows the operator to manually rotate the array to any position.
- 4) The cell locking lever which prevents unit operation if any position is lacking a cell (normal or ballast).
- 5) Cell elevating door which raises the cell to facilitate cell replacement.

In order to remove or change a cell the procedures listed below should be followed:

- 1) Open the entry door (DRIVE READY indicator should go out),
- 2) Open (pull out) the spindle release lever and rotate the array to place the desired cell at the replacement position,
- 3) Press the cell locking lever,
- 4) Lift the cell elevating door (the cell lifts upward about an inch), and

- 5) Place a cell cover over the top of the cell and rotate the cover locking lever counterclockwise. The cell is now engaged by the cover and may be lifted from the unit and placed in protective plastic container (Figure C-19).

To load the unit, reverse the events listed above starting with step 4.

When loading is completed and the entry door is closed, the indicator light pattern should be:

AC-ON	DRIVE OP
DC-ON	DRIVE READY

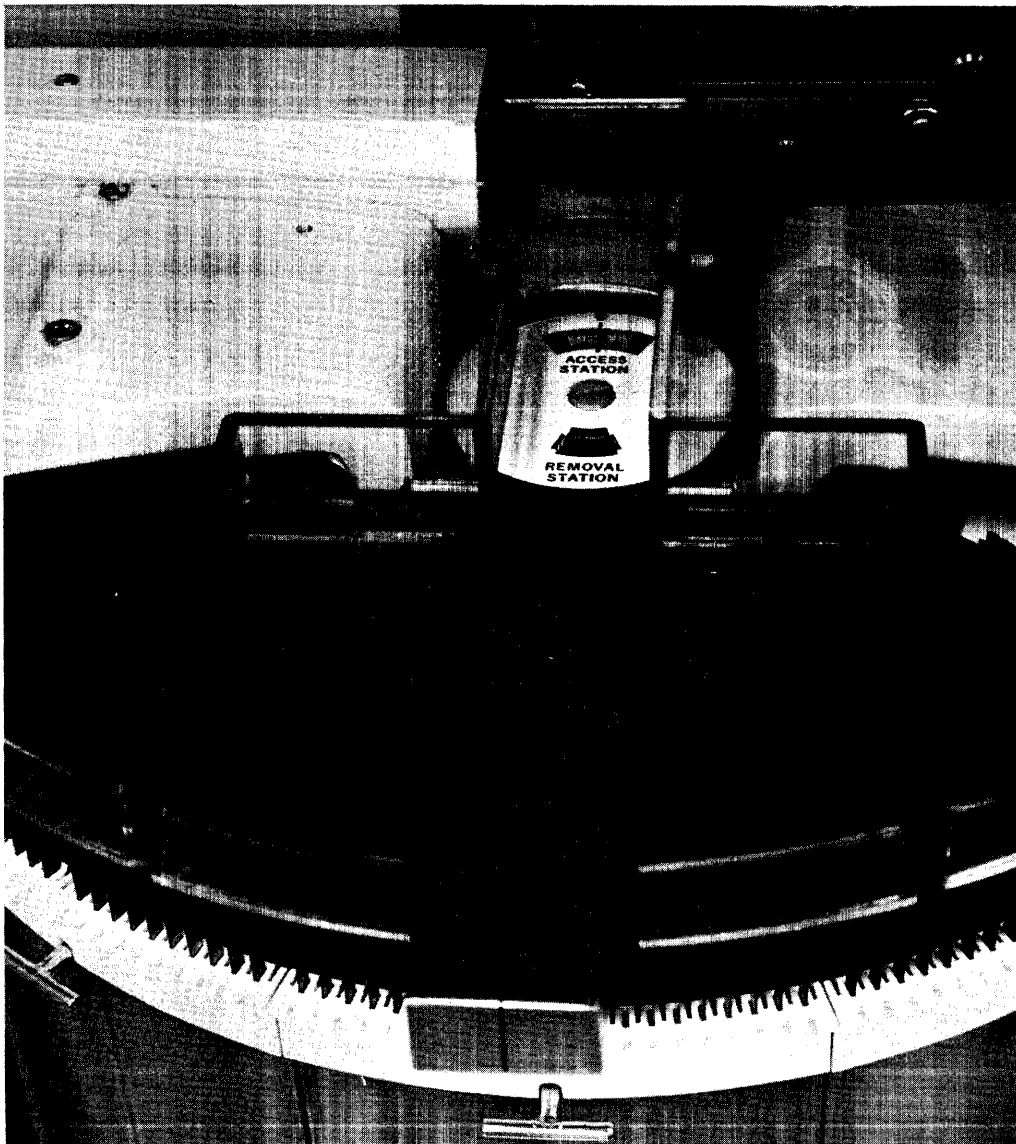
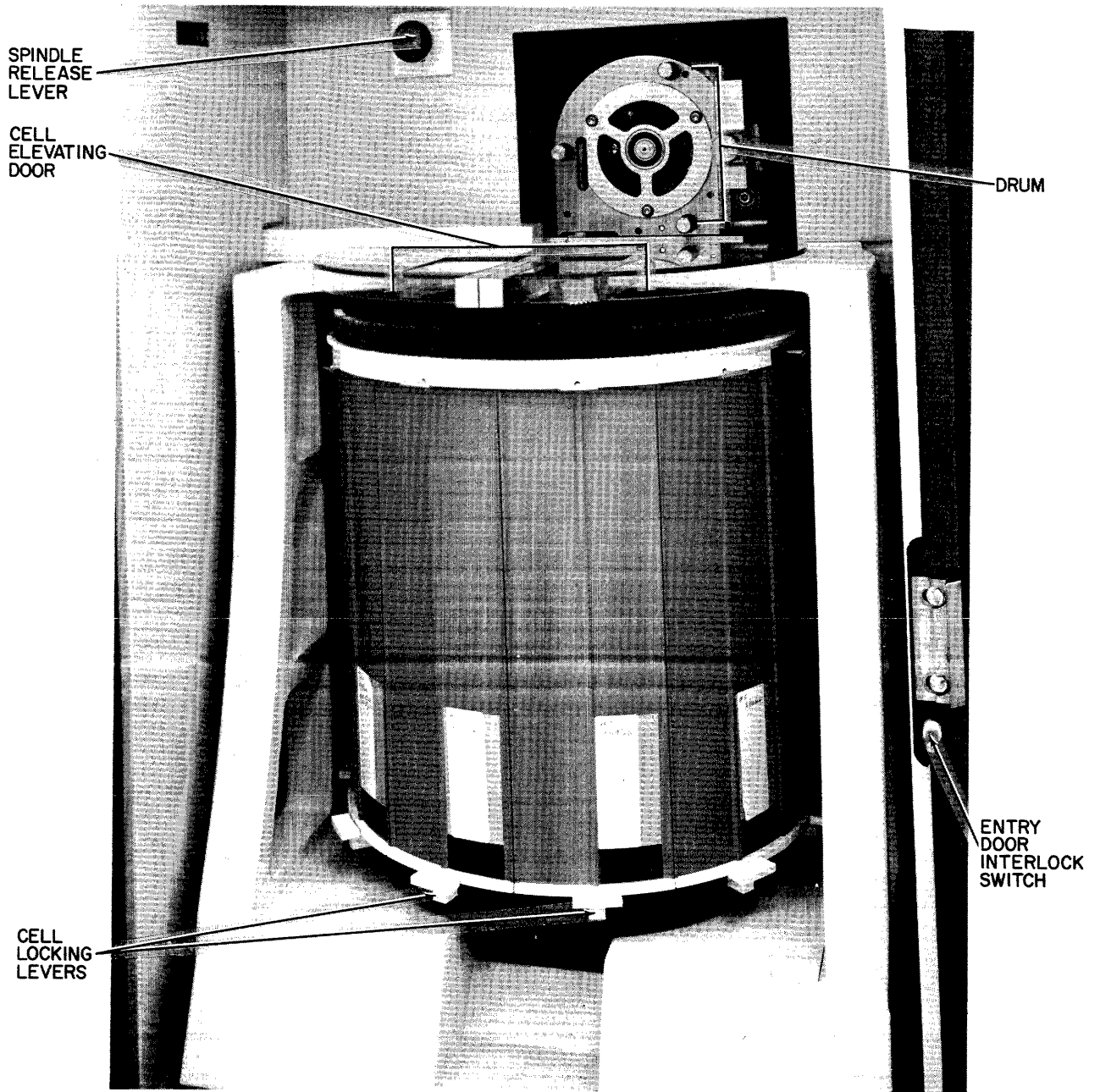

Figure C-17. Cell Indicator and Elevating Door



2129

Figure C-18. Cell Array

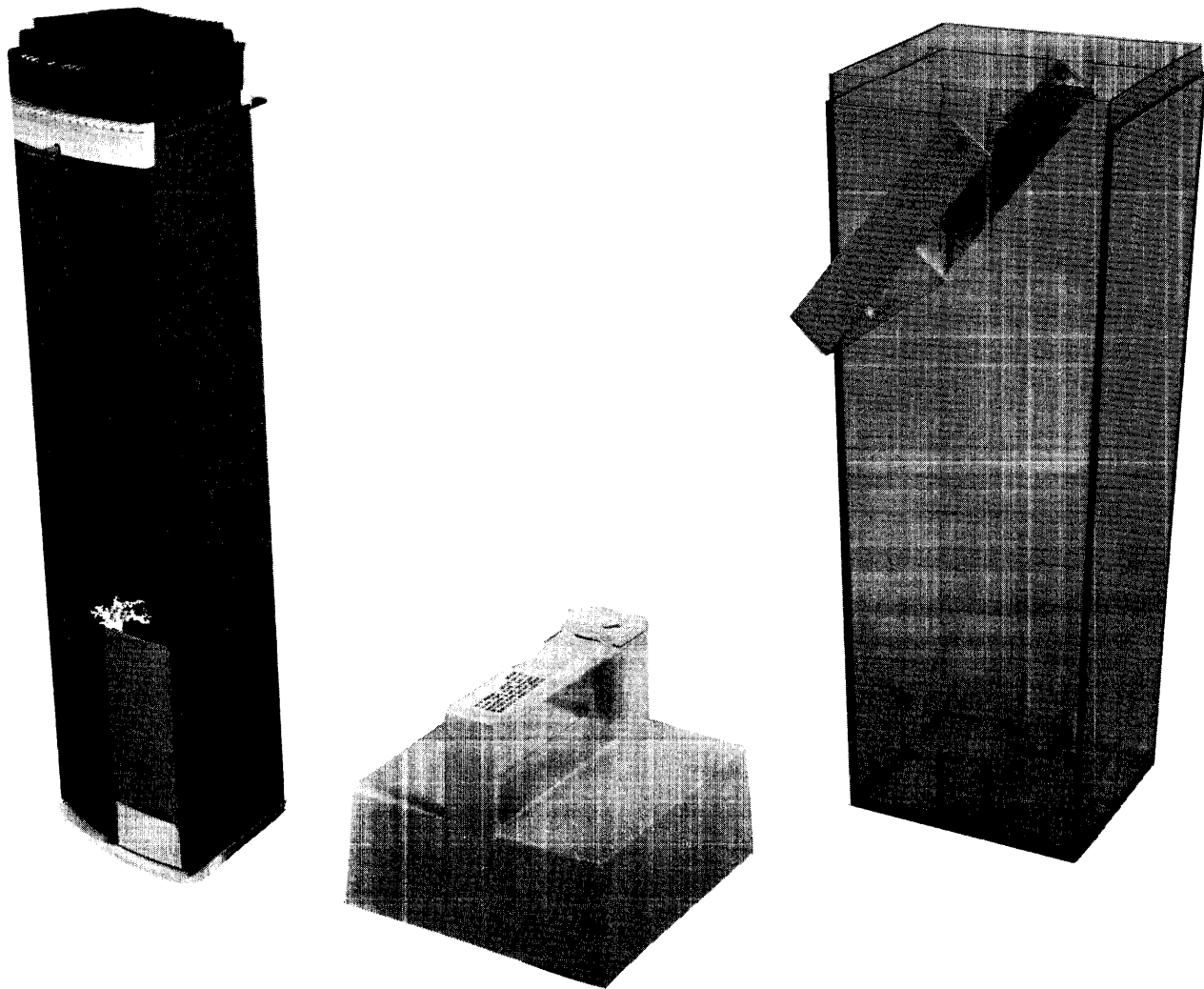

Figure C-19. Cell, Cell Cover, and Protective Container

READY STATE

The mass storage subsystem requires approximately 15 minutes to become operative (Ready) depending on the type of storage in the subsystem configuration.

The controller is always Ready when power is available; however, subsystem readiness (indicated by the Ready status bit) depends upon the state of the selected storage unit.

The requirements and time necessary to bring the subsystem components to the Ready state are:

Disk File

The disk file units are Ready only when all of the following are present:

- 1) Power is available to the disk and hydraulic units,
- 2) The hydraulic and air systems are operating,
- 3) Hydraulic temperature (100^oF) and pressure (1150 psi) are up to normal,
- 4) The disks are spinning and up to speed (1180 rpm), and
- 5) The positioner is in the landing area and the R/W heads are landed and in an operating position.

The disks require approximately 5 minutes to come up to speed; the hydraulic unit requires approximately 15 minutes to come up to the proper operating temperature.

Disk Storage Drive

The disk drive units are Ready only when all of the following are present:

- 1) A pack is loaded,
- 2) The cover is closed,
- 3) The disks are spinning and up to speed (2400 rpm), and
- 4) An initial seek has been performed to position the R/W head (refer to Loading and Unloading Procedures).

The disk drive requires approximately 30 seconds to bring the disks up to speed and perform the initial Seek operation.

Strip File

Strip File units are Ready only when all the following are present:

- 1) A full complement of data cells or ballast (dummy) cells are in the array,
- 2) The cell locking lever is engaged,
- 3) The array door and cell elevating door are closed,

- 4) The spindle release knob is disengaged,
- 5) The drive is operative (power-on and all proper settings etc), and
- 6) A Strip Ready condition exists (the drum is selected and the array stationary).

The strip file requires approximately 10 to 15 seconds to perform a Power On sequence and become ready; however, a 15 minute warm-up period is recommended when commencing from a cold start. In a multiple unit system, each succeeding strip file is automatically sequenced; however, sequencing does not overlap and each file commences only upon completion of the previous file becoming Ready.

3234 CONTROL PANEL

The 3234 maintenance control panel (Figure C-20) is controlled by means of a locking key switch; however, the following items on the panel are active at all times (regardless of whether the panel key switch is in the ON or OFF position).

- 1) The eight LOGICAL/PHYSICAL UNIT designation jumpers
- 2) The two equipment number switches (CONTROL A and CONTROL B) and their associated CONNECTED, RESERVED, and PARITY ERROR indicators.
- 3) The REGISTER SELECT switch.
- 4) The register display indicators.

NOTE

The control panel corporate switches (TRACK, CYL/STRIP, etc.) light up when pressed even when the key switch is in the OFF position; however, the switch function is active only when the key switch is in the ON position.

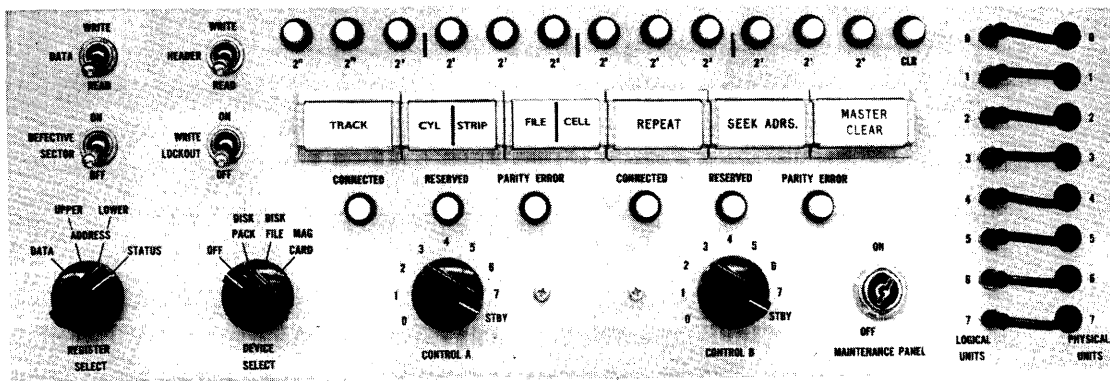

Figure C-20. 3234 Maintenance Control Panel

The purpose and method of use for the various switches and indicators on the panel is explained below. Note that while the panel is designed primarily as a maintenance aid, it is necessary to activate the panel (turn the key switch ON) in order to write Address Headers or to enter Defective Track or Write Lockout bits in the Address Headers.

NOTE

When the Key switch is ON and an ending mode switch (TRACK, CYL etc) is selected, all programmed and/or manual Master Clears from the computer are inhibited. This prevents the possibility of the computer clearing the registers just before a seek is initiated from the panel.

Switches and Indicators

MAINTENANCE PANEL (Key Switch): For normal programmed operation, this switch must be OFF. When this switch is in the ON position all switches and indicators on the panel are active and override any program settings in the controller. The switch is used to activate other switches of the panel.

CONTROL A and CONTROL B (Equipment Number switches and indicators): CONTROL A and CONTROL B are two sets of switches and indicators which provide individual control for each data channel physically connected to the controller. Each set consists of a rotary switch which permits varying the equipment (controller) designation from 0-7 and STANDBY, and a CONNECTED, RESERVED, and PARITY ERROR indicator which light when the associated condition exists in the controller.

LOGICAL/PHYSICAL (Unit Designation Jumpers): These jumper wires provide for varying the LOGICAL/PHYSICAL UNIT designation relationship. The units of the subsystem are permanently wired in at the controller; however, their logical designation may be varied by plugging the appropriate PHYSICAL UNIT jumper into the desired LOGICAL UNIT jack. If strip files are included they must be physical units 0-3. (If less than four strip files are in the subsystem, the higher order numbered units should be removed first.)

NOTE

All panel operations are through LOGICAL UNIT 0; therefore, when operating from the panel the PHYSICAL UNIT to be operated on must be plugged into LOGICAL UNIT 0.

DEVICE SELECT Switch: For normal programmed operation, this switch should be OFF. This rotary switch selects the device type (disk drive, disk file, or strip file) from the maintenance panel. When the Key Switch is ON this switch instantly overrides any previous (present) programmed selection.

REGISTER SELECT Switch: This rotary switch provides the capability for displaying and entering information via the Register Indicators/Switches to or from the register selected.

Register Indicators/Switches: Thirteen indicator type pushbutton switches (CLR and bits 0-11) provide for displaying and/or entering information to and from the register indicated by the setting of the REGISTER SELECT switch. The CLR switch clears only the selected register.

DEFECTIVE TRACK Switch: For normal programmed operations this switch should be OFF. This toggle switch is used to write a Defective Track bit in each sector of the Address Headers (refer to Procedures for Writing Address Headers).

DATA Switch (Write Position): For normal programmed operations, this switch should be in the READ position. This toggle switch provides for writing data from the panel via the Register indicator/switches. The same data (byte) is written in the entire storage area specified by the mode selection (e. g. , TRACK, CYL, etc).

DATA Switch (Read Position): Provides for reading data from the selected storage area. The data read IS NOT displayed in the Data register when operating from the panel; however, a checkword error and other errors are sensed and are displayed in the Status register.

HEADER Switch: For normal programmed operations this switch should be in the READ position. This toggle switch provides for writing or reading address headers in the storage area selected during a control panel operation by the setting of the ending mode switches (see Procedures for Writing Address Headers).

WRITE LOCKOUT Switch: The WRITE LOCKOUT switch, in conjunction with the Key switch determines the degree of data protection provided by the 3234 controller to the subsystem units as follows:

WLO	KEY	HEADER	OPERATION
ON	ON	WRITE/READ	<p>Permits program or panel control.</p> <p>If under program control, the data is protected if the WLO bit in the header = "1". If the WLO bit = 0 the data is unprotected.</p> <p>If under panel control, a header containing a WLO bit = "1" can be written into if the HEADER Switch is in the WRITE position, or the header can be Read if the HEADER Switch is in the READ position. (The data is not protected during panel operations.)</p>
OFF	ON	WRITE/READ	<p>Permits program or panel control.</p> <p>If under program control, the DEVICE SELECT switch and all mode switches (TRACK, CYL, etc) must be in the OFF position.</p> <p style="text-align: center;">CAUTION</p> <p>The data is NOT protected even if the WLO bit = "1". If panel control is desired, the appropriate switches should be set and the SEEK ADDRESS switch pressed to initiate the operation. A header would then be recorded without a WLO bit if the HEADER switch is in the WRITE position or a header would be read if the HEADER switch is in the read position. (The data is NOT protected during panel operations.)</p>
OFF	OFF	WRITE/READ	<p>The program has control. Data is protected if a WLO bit = "1" in the header. The WLO and HEADER switches have no effect when the Key switch is OFF.</p>

Corporate Switches/Indicators

For normal programmed operations these switches should be off. Six indicator/pushbutton corporate switches provide for selecting the ending point of an operating mode (storage area), repeating the selected operation, seeking, and master clearing from the panel. The various switches and their functions are:

TRACK: Selects Track mode wherein the entire track designated by the content of the Address register is operated upon.

CYL/STRIP Switch/Indicator: Selects Cylinder (or strip in the strip file) mode wherein the remainder of the cylinder (strip) designated by the content of the Address register is operated upon, starting at the address held in the Address register.

NOTE

Operation ceases at the end of the selected mode (i. e., the track, cylinder, etc., operated on is read/written only once). See REPEAT switch.

FILE/CELL Switch/Indicator: Selects File (or Cell in the strip file) mode wherein the remainder of the file (cell) designated by the content of the Address register is operated on starting at the address held in the Address register.

NOTE

While it is possible to operate on an entire file, pack, or cell, the entire array cannot be operated on without individually selecting each of the 10 cells. When using this switch the REPEAT switch should be off since a file (cell) will not be repeated automatically.

REPEAT Switch/Indicator: For troubleshooting in a particular mode. When on, this switch causes the selected mode of operation to be continuously repeated; e. g., when in Track mode, the same track is continuously read or written. The Repeat operation halts at the end of the selected storage area when the switch is off.

NOTE

This switch should not be used by the programmer/operator. It is meant for maintenance purposes only. When this switch is used, the controller does not stop for any abnormal conditions unless it is unable to continue.

When in File/Cell mode, this switch should be off. A File/Cell will not be repeated.

SEEK ADRS Switch/Indicator: This switch initiates a Seek operation on the selected unit to the address indicated by the content of the Address register. On completion of the Seek, the selected I/O operation commences.

MASTER CLEAR Switch/Indicator: This switch causes an MC in the controller and selected disk drive or disk file. MC is not used by the strip file. If a MC is performed while a Write operation is in progress, operation ceases immediately. That sector now contains two portions of useless information and will generate a checkword error if a Read operation is attempted. (A No-Op is generated in the strip file.)

Procedures for Writing Address Headers

Address Headers can be written only from the maintenance panel. In order to write the Header, Defective Track, and Write Lockout bits, the following procedure should be followed:

- 1) Turn the maintenance panel Key switch ON.
- 2) Patch the desired PHYSICAL UNIT jumper wire into LOGICAL UNIT 0.
- 3) Set the DEVICE SELECT switch to the desired device type.
- 4) Select the desired ending mode by pressing the appropriate corporate switch (TRACK, CYL, etc).
- 5) Enter the starting addresses into the upper and lower portions of the Address register. (Select the appropriate portion of the Address register via the REGISTER SELECT switch and enter the starting address by pressing the appropriate indicator/pushbutton switches.)
- 6) If there is no good or useable data in the sectors where new headers are to be written, it is recommended that both the HEADER and DATA switch be set to the WRITE position. If there is useful data in the sectors and it is desired that only headers be written, the HEADER switch must be set to the WRITE position and the DATA switch to the READ position.

NOTE

Do not use the REPEAT mode switch when writing headers. Ensure that the REPEAT switch is OFF.

- 7) If Write Lockout and/or Defective Track bits are to be written, these switches should be set to ON.
- 8) Press the SEEK ADRS switch.

The latter (step 8) initiates the operation which will end when the address of the last sector of the selected storage area has been written or an abnormal condition occurs. Any abnormal condition will be displayed in the Status register.

On completion of the operation, select READ HEADERS and READ DATA and read (verify) the area just written. Error conditions will be displayed in the Status register.

NOTE

When in Read Data mode, the data read is not displayed in the Data register.

When complete, return all switches to their normal positions.

Procedures for Writing Data

Data can be written from the maintenance panel. The procedure is to read headers and write data. To accomplish this, the following procedures should be followed:

- 1) Turn the maintenance panel Key switch ON.
- 2) Patch the desired PHYSICAL UNIT jumper wire into LOGICAL UNIT 0.
- 3) Set the DEVICE SELECT switch to the desired device type.
- 4) Select the desired storage mode by pressing the appropriate corporate switch (TRACK, CYL, etc).
- 5) Enter the data to be written into the Data register. Select the appropriate Data register via the REGISTER SELECT switch and enter the data by pressing the appropriate indicator/pushbutton switches.
- 6) Set the HEADER switch to READ and the DATA switch to WRITE.
- 7) The WRITE LOCKOUT and/or DEFECTIVE TRACK switches should be OFF
- 8) Press the SEEK ADRS switch.

Step 8) initiates the operation which will end when the last sector of the selected storage area has been written or an abnormal condition occurs. Any abnormal condition will be displayed in the Status register.

On completion of the operation, select READ HEADERS and READ DATA and read (verify) the area just written. Error conditions will be displayed in the Status register.

NOTE

When in Read Data mode, the data read is not displayed in the Data register.

When complete, return all switches to their normal positions.

SAMPLE PROGRAM ROUTINES

To aid in understanding the 3234 Mass Storage Subsystem, two sample programs (A and B) are included here. Each program is preceded by a short explanation of the program and an associated flow chart. Both routines are written in 3200 COMPASS language.

PROGRAM SEQUENCE

The basic programming sequence is:

SEQUENCE	COMMENT
1) Connect	Connect code selects controller and peripheral unit (if available).
Select Response	If the connect operation is successful, a Reply is returned; if not (controller or peripheral unit unavailable), a Reject is returned. Return to Connect after determining the cause of the Reject.
2) Select Interrupts	Any desired interrupt conditions should be selected at this point.
3) Load Address	If a new address location (other than the one presently held in the controller Address register) is desired, it should be sent prior to the execution of an operating mode selection.
4) Select Operating Modes	Function code selects the desired modes of operation.
5) Set up R/W	Function code selects a read or write function.
6) Initiate Operation	Receipt of a Read or Write signal initiates operation within the selected unit. Completion of the operation may be detected through the End of Operation interrupt or dropping of the Busy Status bit.

PROGRAM A

This routine assumes the 3234 controller to be on channel 3 as equipment 5 with an 853 Disk Storage Drive as unit 0 and an 813 Disk File as unit 1. The routine utilizes the Overlap Seek feature by initiating positioner movement in first the disk drive, and then initiating positioner movement in the disk file. The routine then loops, searching for a successful Positioner Ready status on either unit. As soon as a Positioner Ready status is located, that unit is readdressed and one sector of data is written. The unit is re-addressed again and a Compare is performed to determine if the data was correctly written. (If the data is incorrectly written, the Write and Compare operations are performed again.)

Upon completion of a successful Compare, a similar operation is performed on the other unit. After both units have been written on and successful compares made, the program stops.

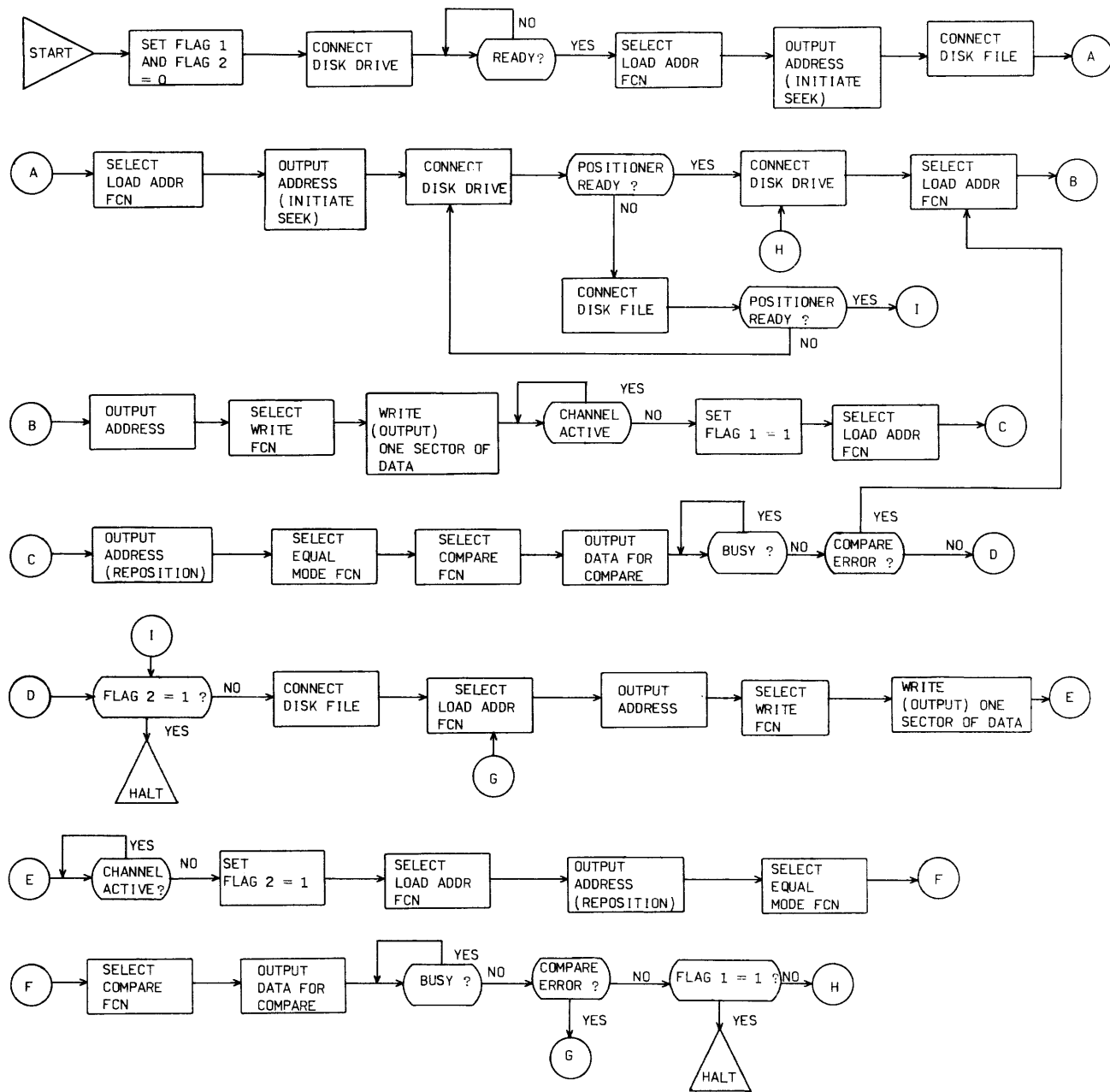

Figure C-21. Flow Chart, Program A

AA	ENA	0	
	STA	FLAG 1	
	STA	FLAG 2	
A	CON	5010B, 3	Connect Disk Drive Zero on
	UJP	A	Equipment 5 Channel 3
	EXS	1, 3	Check for Ready Status
	UJP	*+2	
	UJP	*-2	
B	SEL	10B, 3	Load Address Function
	UJP	B	
C	OUTW	3, ADDRESS 1, ADDRESS 1+1	Output Disk Drive Address
	UJP	*-2	
D	CON	5021B, 3	Connect Disk File One on
	UJP	D	Equipment 5 Channel 3.
	SEL	10B, 3	Load Address
	UJP	*-1	
	OUTW	3, ADDRESS 2, ADDRESS 2+1	Output Disk File Address
	UJP	*-2	
DD	CON	5010B, 3	Reconnect Disk Drive
	UJP	*-1	
	EXS	200B, 0	Check for the First Unit
	UJP	E	that will have Positioner Ready
	CON	5021B, 3	Reconnect Disk File
	UJP	*-1	
	EXS	200B, 3	Check Positioner Ready
	UJP	F	
DDD	UJP	DD	
E	CON	5010B, 3	
	UJP	*-1	
ERR	SEL	10B, 3	Load Address
	UJP	*-1	Reset the Address Register
	OUTW	3, ADDRESS 1, ADDRESS 1+1	for the Disk Drive
	UJP	*-2	
	SEL	41B, 3	Select Write Function
	UJP	*-1	
	OUTW	3, DATA, DATA +64	Write one Sector of Data
	UJP	*-2	
	PAUS	40B	Wait Channel Inactive
	UJP	*-1	
	ENA	1	

	STA	FLAG 1	
	SEL	10B, 3	Reposition the Disk Drive
	UJP	*-1	
	OUTW	3, ADDRESS 1, ADDRESS 1+1	
	UJP	*-2	
	SEL	52B, 3	Select Equal Mode
	UJP	*-1	
	SEL	42B, 3	Select Compare Function
	UJP	*-1	
	OUTW	3, DATA, DATA +64	Output Data for Compare
	UJP	*-2	
	EXS	2, 3	Wait Not Busy
	UJP	*-1	
	EXS	20B, 3	Compare Error
	UJP	ERR	Must Rewrite Data
F	LDA	FLAG 2	Has Disk File been written on?
	AZJ, NE	H	(If yes, Flag 2=1)
	CON	5021B, 3	
	UJP	*-1	
ERR 1	SEL	10B, 3	
	UJP	*-1	Reposition the Disk File
	OUTW	3, ADDRESS 2, ADDRESS 2+1	
	UJP	*-2	
	SEL	41B, 3	
	UJP	*-1	
	OUTW	3, DATA 1, DATA 1+64	Write One Sector
	UJP	*-2	of Data
	ENA	1	
	STA	FLAG 2	
	PAUS	40B	Wait Channel Inactive
	UJP	*-1	
	SEL	10B, 3	Reposition the Disk File
	UJP	*-1	
	OUTW	3, ADDRESS 2, ADDRESS 2+1	
	UJP	*-2	
	SEL	52B, 3	Select Equal Mode
	UJP	*-1	
	SEL	42B, 3	Select Compare Function
	UJP	*-1	
	OUTW	3, DATA 1, DATA 1+64	Output Data for Compare

	UJP	*-2	
	EXS	2, 3	Wait Not Busy
	UJP	*-1	
	EXS	20B, 3	Compare Error
	UJP	ERR 1	Must Rewrite Data
	LDA	FLAG 1	Has Disk Pack been written on?
	AZJ, EQ	E	(If yes, Flag 1=1)
H	HLT	*	End
ADDRESS 1	OCT	01400220	Disk Drive Address
ADDRESS 2	OCT	01200776	Disk File Address

PROGRAM B

This routine assumes the 3234 controller (equipped with Special Option 60076)* to be on channel 3 as equipment 1 with a strip file as unit 2. Two tests are performed which calculates the time (in milliseconds) to perform the following:

- 1) The time required to pick one strip.
- 2) The time for the drum (which rotates the selected strip past the R/W heads) to make one revolution.

The routine loops 10 times during the first test (operation) and then types out the maximum, average, and minimum time required to perform the operation; a similar looping and typeout is then performed for the second test (operation). The process time and typeout subroutines are not actually included in this program sample.

* Special Option 60076 is the adaptor for the 2321 Data Cell (Strip File).

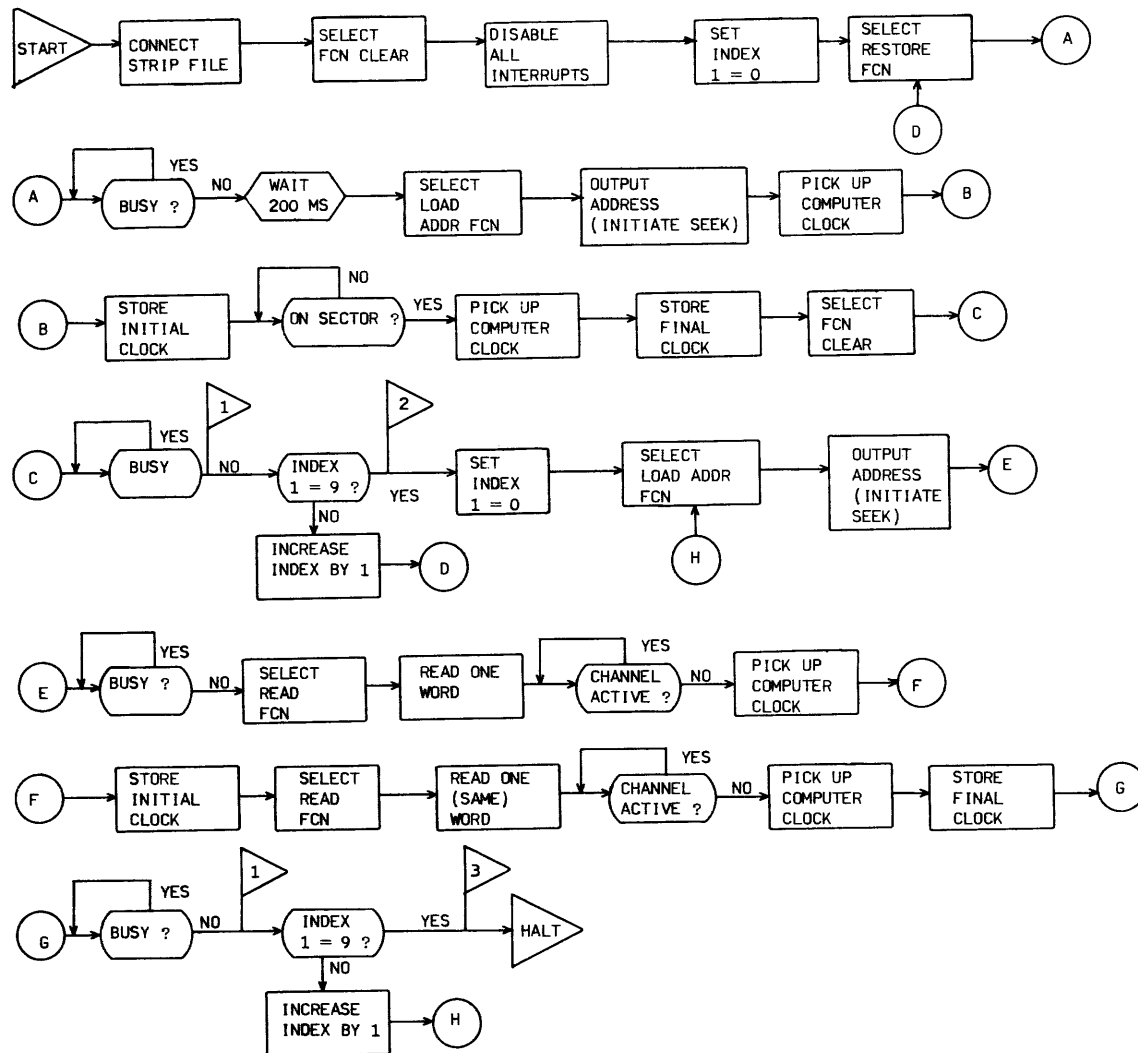

- 1 PROCESS TIME STORED IN INITIAL AND FINAL CLOCKS
- 2 TYPEOUT MAXIMUM, AVERAGE, AND MINIMUM TIMES TO PICK STRIP. (TIME IS IN MILLISECONDS)
- 3 TYPEOUT MAXIMUM, AVERAGE, AND MINIMUM TIMES FOR DRUM TO MAKE 1 REVOLUTION (TIME IS IN MILLISECONDS)

Figure C-22. Flow Chart, Program B

CON	1002B, 3	Connect to Unit-2, Equip-1, Chan-3
UJP	*-1	
SEL	5, 3	Function Clear to Knock-Down on Sector Status
UJP	*-1	
DINT		Disable Interrupts
ENI	0, 1	Counter to Repeat 10 Times

A	SEL	1, 3	Restore Strip
	UJP	*-1	
	EXS	1, 3	Wait Controller Not Busy
	UJP	*-1	
	TMA	22B	} Wait 200 ms to Make Sure Restore is Complete
	INA	200	
	STA	STOR	
	LDQ	STOR	
	TMA	22B	
	AQJ, LT	*-2	
	SEL	10B, 3	
	UJP	*-1	
	OUTW	3, ADDRESS, ADDRESS +1	Output Address (Initiate Seek)
	UJP	*-2	
	TMA	22B	Pick up Clock as Soon as Output Initiated
	STA	CLOCK I	Store Initial Clock
	EXS	10B, 3	Wait on Sector Status
	UJP	*+2	
	UJP	*-2	
	TMA	22B	On Sector-Store Final Clock
	STA	CLOCK F	
	SEL	5, 3	Function Clear to Knock Down on Sector Status
	UJP	*-1	
	EXS	1, 3	Wait Controller Not Busy
	UJP	*-1	

Process time stored in CLOCK I and CLOCK F.

ISI	9, 1	Repeat 10 Times
UJP	A	

Timeout maximum, average, and minimum times to pick one strip.

B	ENI	0, 1	
	SEL	10B, 3	Select Load Address
	UJP	*-1	
	OUTW	3, ADDRESS, ADDRESS +1	Output Address (Initiate Seek)
	UJP	*-2	
	EXS	1, 3	Wait Controller Not Busy

UJP	*-1	
SEL	40B, 3	Select Read Function
UJP	*-1	
INPW	3, BUFFER, BUFFER +1	Read One Word
UJP	*-2	
PAUS	10B	Wait Channel Inactive
UJP	*-1	
TMA	22B	Channel Inactive - Store Initial Clock
STA	CLOCK I	
SEL	40B, 3	Select Read Function
UJP	*-1	
INPW	3, BUFFER, BUFFER +1	Read One Word
UJP	*-2	
PAUS	10B	Wait Channel Inactive
UJP	*-1	
TMA	22B	Channel Inactive - Store Final Clock
STA	CLOCK F	
EXS	1, 3	Wait Controller Not Busy
UJP	*-1	

Process time stored in CLOCK I and CLOCK F

ISI	9, 1	Repeat 10 Times
UJP	B	
HLT	*	End

Typeout maximum, average, and minimum times for one drum revolution in milliseconds.

ADDRESS	OCT	10330044	Address Cell=2 Strip=33 Track (Sector)=44
STOR	OCT	0	
CLOCK I	OCT	0	
CLOCK F	OCT	0	
BUFR	BSS	500B	Read Buffer

SECTION A

3681-A DATA CHANNEL CONVERTER

CONTENTS

Functional Description	A-1	Connect	A-5
Satellite	A-2	Function	A-6
Nonsatellite	A-2	Read (Input to Computer)	A-8
Code Select Switch	A-2	Write (Output from Computer)	A-9
Codes	A-2	Status Responses	A-10
Function Codes	A-3	Interrupt	A-11
Operational Procedures	A-5	Programming Example	A-12

FIGURES

A-1 Typical Configurations	A-1
----------------------------	-----

TABLES

A-1 Function and Status Codes	A-3
-------------------------------	-----

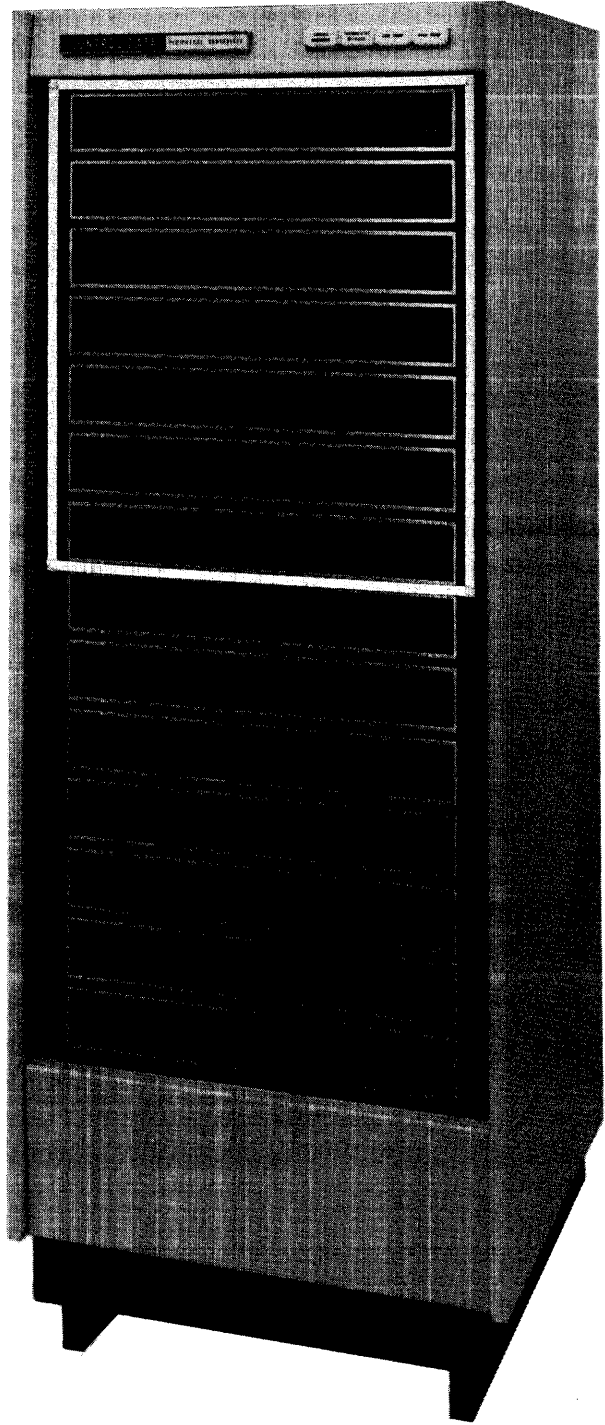

3681 DATA CHANNEL CONVERTER

3681-A DATA CHANNEL CONVERTER

The CONTROL DATA* 3681 Data Channel Converter simulates a 3000 Series data channel, allowing a CONTROL DATA 160/160-A Computer to communicate with 3000 Series peripheral equipments. (See Figure A-1.) The 160/160-A Computer may perform Connect, Function, Read, Write, and Status operations on these equipments via the 3681 Converter.

FUNCTIONAL DESCRIPTION

The 160/160-A Computer transmits codes to the 3681 Converter prior to starting any operation on an external equipment (see Table A-1 for 3681 Converter Function and Status codes). These codes establish conditions in the converter so that the proper 3000-type signals accompany 160/160-A Computer Input/Output operations. (These 3000-type signals are Connect, Function, Data, Read, and Write.)

3000 Series External Equipments

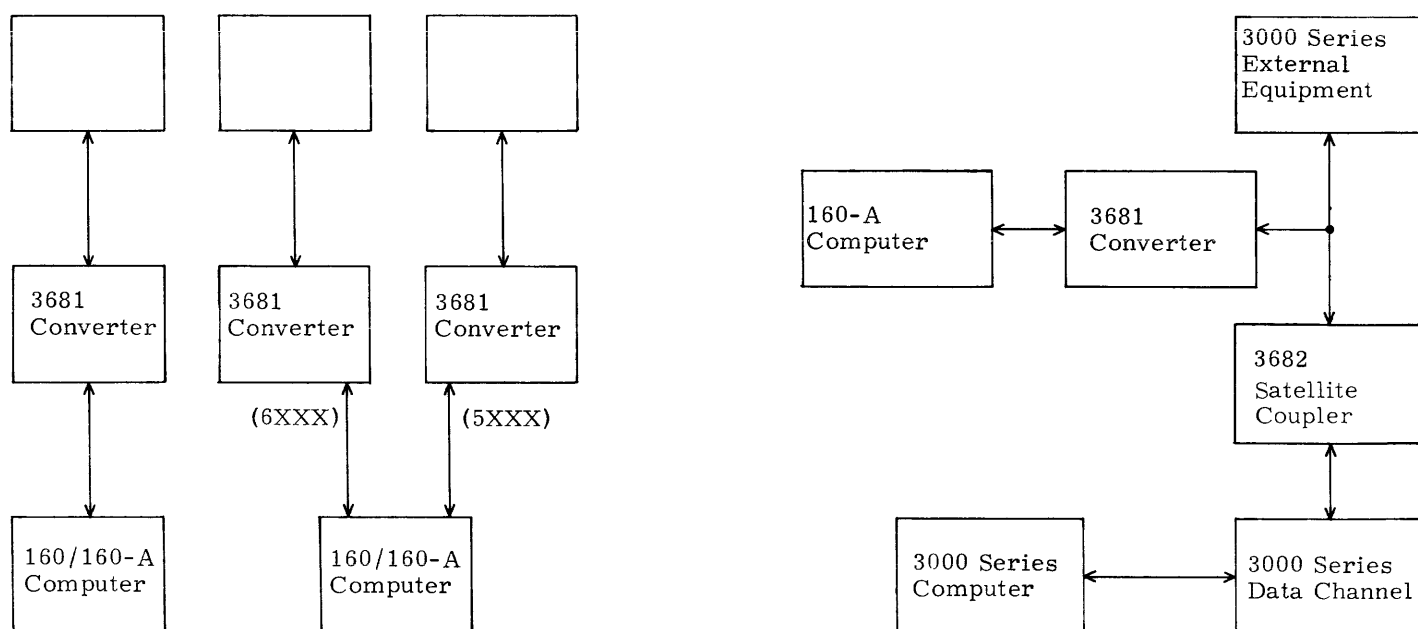

*A maximum of eight equipments per 3681 Converter are permitted.

Figure A-1. Typical Configurations

*Registered trademark of Control Data Corporation

A parity bit is added to the 12 bits coming from the 160/160-A Computer when exchanging information with external equipments (odd parity on transmission).

Two 3681 Converters can be run from one 160/160-A Computer by using Function codes 6XXX and 5XXX.

SATELLITE*

Figure A-1 shows the 3681 Converter and 160-A Computer as related to a Satellite system.

NONSATELLITE

Figure A-1 shows two possible nonsatellite configurations. The 160/160-A Computer can communicate with eight 3000 Series equipments, such as a tape controller, card reader, card punch, etc. A second converter can be connected to additional 3000 Series devices.

CODE SELECT SWITCH

A Code Select switch (located on the rear chassis) determines which function codes the 3681 Converter recognizes. If the switch is set to position 5 (down), the converter responds to 5XXX codes; in position 6 (up), it responds to 6XXX codes. Interrupt 40** corresponds to position 6, Interrupt 30** to position 5.

If more than eight 3000 Series equipments are to be used, two 3681 Converters are required. In this case, the Code Select switch on one is set to 5 and on the other to 6.

CODES

Table A-1 lists the Function and Status codes applicable to the 3681 Converter. In all discussion of codes, bit 0 is the rightmost position.

*Registered trademark of Control Data Corporation

**Interrupts 30 and 40 are 160/160-A interrupts.

TABLE A-1. FUNCTION AND STATUS CODES

FUNCTION	
Channel Status	5001/6001
Equipment Status	5002/6002
Master Clear	5003/6003
Connect Initiate	5004/6004
Function Initiate	5010/6010
Read	5020/6020
Negate BCD Conversion on Read	5120/6120
Write	5040/6040
Negate BCD Conversion on Write	5140/6140
Clear Functions	5200/6200
Clear Functions and Interrupt	5400/6400
STATUS	
Reject*	XXX1
Transmission Parity Error	XXX2
Interrupt - Equipment 0	XXX4
Interrupt - Equipment 1	XX1X
Interrupt - Equipment 2	XX2X
Interrupt - Equipment 3	XX4X
Interrupt - Equipment 4	X1XX
Interrupt - Equipment 5	X2XX
Interrupt - Equipment 6	X4XX
Interrupt - Equipment 7	1XXX

FUNCTION CODES

The function codes used with the 3681 Converter are, for the most part, enabling codes. They permit the converter to prepare for a Connect, Function, Read, or Write operation or request for Status. The 160/160-A Function instructions must be used to send these codes to the converter.

The upper octal digit of a function code must match the setting of the two-position Code Select switch. If the switch is in the 5 position (down), the converter responds to 5XXX codes. The converter accepts on 6XXX codes when the switch is in the 6 position (up).

*A transmission parity error, a reject, or any of the eight interrupt lines interrupt the 160-A Computer. The 160 Computer has no interrupt feature.

Channel Status (5001/6001)

This code prepares the 3681 Converter for a transmission of channel status to the 160/160-A Computer.

Equipment Status (5002/6002)

This code prepares the 3681 Converter for a transmission of equipment status to the 160/160-A Computer.

Master Clear (5003/6003)

This code causes the 3681 Converter to send a Master Clear to all 3000 Series equipments attached to it.

Connect Initiate (5004/6004)

This code enables the 3681 Converter to generate a parity bit and a Connect signal to accompany the Connect code (NXXX)* when the Connect code is transmitted from the 160/160-A Computer.

Function Initiate (5010/6010)

This code enables the 3681 Converter to generate a parity bit and a Function signal to accompany the function code when the function code is transmitted from the 160/160-A Computer.

Read (5020/6020)

This code enables the 3681 Converter to generate and transmit a Read signal to the equipment.

Negate BCD Conversion on Read (5120/6120)

This code negates the normal external to internal BCD conversion which occurs in some peripheral devices if it is sent to the 3681 Converter prior to sending the Read code (5020/6020).

*See individual equipment Connect codes.

The Negate BCD Conversion on Read selection is only cleared with a Master Clear or a Master Clear code (5003/6003). The program must wait for Ready and Not Busy signals from the external equipment before issuing the Master Clear code (5003/6003) to insure that the Input/Output operation is complete.

Write (5040/6040)

This code enables the 3681 Converter to generate and transmit a Write signal to the equipment.

Negate BCD Conversion on Write (5140/6140)

This code negates the normal internal to external BCD conversion if it is sent to the 3681 Converter prior to sending the Write code (5040/6040).

The Negate BCD Conversion on Write selection is only cleared with a Master Clear or a Master Clear code (5003/6003). The program must wait for Ready and Not Busy signals from the external equipment before issuing the 5003/6003 code to insure that the Input/Output operation is complete.

Clear Functions (5200/6200)

This code clears all functions in the 3681 Converter. It does not clear an Interrupt signal originating in the 3681 Converter.

Clear Functions and Interrupt (5400/6400)

This code clears all functions and an interrupt caused by a Reject.

OPERATIONAL PROCEDURES

CONNECT

The connection of 3000 Series equipments to a 160/160-A Computer via a 3681 Converter requires two steps.

Step A

A Connect Initiate code (5004/6004) is sent to the 3681 Converter, using a 7500 EXC External Function instruction. This code prepares the converter to send a Connect code to the attached external equipments.

If bits 9, 10, and 11 of the Connect Initiate code do not match the setting of the Code Select switch, the operation hangs up unless another converter responds to the code.

Step B

An Output instruction in the computer sends a 12-bit Connect code to the 3681 Converter. The converter generates a transmission parity bit and forwards the 12-bit Connect code, parity bit, and Connect signal to the external equipment. (If the Connect Initiate code has not preceded this step, the program hangs up.) The external equipment responds with a Reply, a Reject, or no signal.

If the external equipment connects, it returns a Reply to the converter and the computer goes on to the next instruction.

If the external equipment does not connect, it returns a Reject to the converter. A Reject enables the computer to proceed with the next instruction. When a 160-A Computer is used, a Reject causes the computer to interrupt.* If the computer interrupt lockout is not in effect, the main program is interrupted. If interrupt lockout is in effect, the interrupt is ignored and the computer goes on to the next instruction.

When a 160 Computer is used, a status check should follow a Connect operation to determine if the external device has successfully connected. Bit 0 of the Channel Status response is "1" if the external device has rejected the Connect code.

If the external device returns neither a Reply nor Reject (e. g., in the case of a transmission parity error or selection of a nonexistent equipment), the computer program halts indefinitely.

FUNCTION

Two steps are required to send a function code to an external equipment.

*The 160 Computer has no interrupt feature.

Step A

A 7500 EXC External Function instruction sends the 12-bit Function Initiate code (5010/6010) to the 3681 Converter. This code prepares the converter to send a function code to the connected external equipment.

Step B

A normal Output instruction in the 160/160-A Computer sends a 12-bit function code and an Information Ready signal to the converter. The converter generates a parity bit and sends the 12-bit function code, parity bit, and Function signal to the external equipment. (If the Function Initiate code has not preceded this step, the computer program halts.)

If the external equipment accepts the function code, it returns a Reply* which enables the computer to proceed with the next instruction.

If the external equipment does not accept the function code, it returns a Reject. This signal enables the computer to execute the next instruction. If a 160-A Computer is used,** a Reject causes the converter to send an Interrupt signal to the 160-A Computer. Typically, an interrupt routine checks status to determine the cause of the interrupt, in this case a Reject.

When a 160 Computer is used, a status check should follow a Function operation to determine if the device has accepted the code. Bit 0 of the Channel Status response is "1" if the external device has rejected the function code.

If neither a Reply nor Reject is returned to the converter (e.g., in case no equipment is connected), the computer program cannot proceed.

*Certain do-nothing codes also cause a Reply, but no action follows.

**The 160 Computer has no interrupt feature.

READ (INPUT TO COMPUTER)

A Read operation transfers a series of 12-bit bytes from an external equipment to the computer via the 3681 Converter. The external equipment must be connected before a Read can begin. Two steps are required to initiate a Read operation.

Step A

A 7500 EXC External Function instruction sends the 12-bit Read code (5020/6020) to the 3681 Converter. When the read logic sets, Read and Channel Busy signals are sent to the external equipment. (These two signals remain up until the read logic is cleared.) In most cases, step B must be entered immediately after step A because, for example, when a tape controller receives a Read signal, tape motion starts. There is some time available between steps A and B, but this time interval depends on the characteristics of each external equipment.

Step B

A normal Input instruction initiates a Read operation. The external device then transfers the number of 12-bit bytes specified by the Input instruction. When the Read operation is complete, the read logic should be cleared immediately by a Master Clear code (5003/6003) or Clear Functions code (5200/6200).

Input Disconnect

If the 3681 Converter receives an End of Record signal from the external equipment during a Read operation, it sends an Input Disconnect signal to the computer. This terminates the current Input operation in the computer. The 3681 Converter drops the Input Disconnect signal when the End of Record signal from the external equipment drops.

The converter also sends an Input Disconnect signal to the computer if a Busy signal is not returned to the converter 25 microseconds after the Read operation begins. (This would apply, for example, in the case where a card jams in a card reader.) The Input Disconnect drops when the Input Request from the computer drops.

Word Mark

When the converter receives the fourth Input Request from the computer, a Word Mark signal is sent to the external equipment. This signal drops when the Input Request from the computer drops.

If the Read operation terminates before the computer has received 4 12-bit bytes, any new 7500 EXC External Function instruction or Master Clear from the computer resets the Word Mark counter.

Parity Checking

The converter does not check for transmission parity errors between the 160/160A Computer and the Converter on a Read operation.

WRITE (OUTPUT FROM COMPUTER)

A Write operation transfers a series of 12-bit bytes (output words) from the computer to an external equipment via the 3681 Data Channel Converter. The external equipment must be connected before the Write begins. Two steps are required to initiate a Write operation.

Step A

A 7500 EXC External Function instruction sends the 12-bit Write code (5040/6040) to the 3681 Converter. When the write logic sets, Write and Channel Busy signals are sent to the external equipment. (These two signals remain up until the Write logic clears.) In most cases, step B must be initiated immediately after step A because, for example, when a tape controller receives a Write signal, tape motion starts. There is some time available between steps A and B, but this time interval depends on the characteristics of each external equipment.

Step B

A normal Output instruction initiates a Write operation. The computer then transfers the number of bytes (output words) specified by the Output instruction. When the Write operation is complete the write logic should be immediately cleared by a Master Clear code (5003/6003) or Clear Functions code (5200/6200).

Word Mark

When the converter receives the fourth Information Ready signal from the computer, a Word Mark signal is sent to the external equipment. This signal drops when the Information Ready signal from the computer drops.

If the Write operation terminates before the computer has sent 4 12-bit bytes to the converter, any new 7500 EXC External Function instruction or a Master Clear from the computer resets the Word Mark counter.

Parity Checking

The converter does not check for transmission parity errors between the 160/160-A Computer and converter during a Write operation.

End of Record Gap

If an end of record gap is required between two outputs, the Write signal must be cleared and reset.

STATUS RESPONSES

Two types of status responses are available from the converter:

- 1) Channel status
- 2) Equipment status

Channel Status

Table A-1 lists the Status codes. Use of the channel status response depends on whether a 160 or 160-A Computer is used to control the converter.

When a 160-A Computer is used, the channel status response is used to determine which one of several conditions has caused an interrupt. Each of the interrupt conditions is indicated by a status bit listed in Table A-1.

The 160 Computer has no interrupt feature. When a 160 Computer controls a 3681 Converter, the Channel Status response is normally used to:

- 1) Determine if the external equipment has responded to Connect or Function operation with a Reply or a Reject.
- 2) Determine if a transmission parity error has occurred during a Read or Write operation.

A 7500 EXC External Function instruction sends a 12-bit Channel Status code (5001/6001) to the converter. In response to this code, the converter places the 10 bits of channel status information on the computer input lines. An Input to A instruction (INA) can then be used to read the status response into the computer where it can be checked.

Equipment Status

Usually the condition of an external equipment is available on status lines after the external equipment has been connected. The Equipment Status code (5002/6002) is used to enable the computer to sample the information on the status lines.

A 7500 EXC External Function instruction sends the 12-bit Equipment Status code (5002/6002) to the converter. In response to this code, the converter places the status response from the connected external equipment on the computer input lines. An Input to A instruction (INA) can then be used to read the status response into the computer where it can be checked.

INTERRUPT*

Any of the following conditions causes the converter to send an Interrupt signal to the computer.

- 1) A Reject signal from an external device.
- 2) A transmission parity error.
- 3) An Interrupt signal from any of the external devices attached to the converter.

There are two external interrupt lines labeled Interrupt 30 and Interrupt 40. Each signal transfers program control to a different memory location. If the Code Select switch is in position 6, the converter sends Interrupt 40 when one of the above conditions occurs. If the switch is in position 5, the converter uses Interrupt 30.

A channel status response identifies which of the several conditions caused an interrupt.

An Interrupt signal remains on the line until cleared. The Clear Functions and Interrupt code (5400/6400) clears the interrupt when caused by a Reject. The normal external equipment function codes enable the computer to clear an interrupt from an external equipment.

*160-A Computer only

PROGRAMMING EXAMPLE

A 160-A Computer is connected to a 3681 Converter. The switch on the converter is set to position 6 (6XXX codes). The converter is connected to control A on a 362X Tape Controller (control A is set to accept equipment 0). A 606 Tape Unit (bank 1, tape 0 = tape 10) is connected to the controller.

Sixty-four (100_8) words are stored in locations 1300, 1377 in the 160-A Computer. Write them on tape 10 in 556 BPI BCD. Tape 10 is at load point. Rewind when the Write operation is complete. Halt the program if any steps in the above operations are not completed or an interrupt is generated. Refer to the 160-A Computer Reference Manual (Pub. No. 60014500) for a detailed discussion of instructions used in this program.

Set direct, indirect, and relative bank controls to 0.

Do a Master Clear.

Start program at address 1000.

<u>Location</u>	<u>Contents</u>	<u>Comments</u>
1000	7500	EXC
1001	6004	G = Connect Initiate
1002	7366	Output (FWA = 1202)
1003	1203	G = LWA + 1 = 1203
1004	0120	Clear Interrupt Lockout
1005	0001	No Operation
1006	7500	EXC
1007	6002	G = Controller Status
1010	7600	INA (12-bit Controller Status → A)
1011	0201	LPN (Check for bit 0 = Ready)
1012	6102	Non-Zero Jump Forward
1013	7700	HALT if Ready Not Present
1014	7600	INA (12-bit Controller Status → A)
1015	1005	LPD (Check for bit 2 = Write Enable)
1016	6102	Non-Zero Jump Forward
1017	7700	HALT if Write Enable Not Present
1020	7500	EXC
1021	6010	G = Function Initiate
1022	7347	Output (FWA = 1200)
1023	1201	G = LWA + 1201
1024	0120	Clear Interrupt Lockout
1025	0001	No Operation
1026	7345	Output (FWA = 1201)
1027	1202	G = LWA + 1 = 1202
1030	7500	EXC
1031	6000	G = Write
1032	7346	Output (FWA = 1300)
1033	1400	G = LWA + 1 = 1400
1034	7500	EXC
1035	6002	G = Controller Status

<u>Location</u>	<u>Contents</u>	<u>Comments</u>	
1036	0120	Clear Interrupt Lockout	
1037	0001	No Operation	
1040	7600	INA (12-bit Controller Status → A)	Check controller
1041	0202	LPD (Check for bit 1 = 0)	and wait
1042	6002	ZJF (Zero Jump Forward)	for Not
1043	6503	NZB (Non-Zero Jump Backward)	Busy
1044	0120	Clear Interrupt Lockout	
1045	0001	No Operation	
1046	7500	EXC	Rewind
1047	6010	G = Function Initiate	tape 10
1050	7323	Output (FWA = 1203)	to load
1051	1204	G = LWA + 1 = 1204	point
1052	0120	Clear Interrupt Lockout	
1053	0001	No Operation	
1054	7700	Halt Program	Halt
0005	0004	Logical Product Operand	
0040	----	Store P on Interrupt 40	
0041	7500	EXC	
0042	6001	Channel Status	
0043	7600	INA (Channel Status → A)	
0044	7700	HALT	
1070	1202		
1071	1200		
1072	1201		
1073	1203		
1100	1300		
1101	----		
1200	0002	Set Controller to BCD	
1201	0003	Set Controller to 556 BPI	
1202	0010	Connect Code (Control A, Tape 10)	
1203	0010	Rewind Tape 10	
1300	----		1008 Words
1377	----		stored in
			locations
			1300 → 1377

Program Explanation

Begin by doing a computer Master Clear and setting the direct, indirect, and relative bank controls to 0.

Address 1004 contains a Clear Interrupt Lockout instruction which enables an interrupt to halt the program one program step after doing a clear interrupt lockout. If an interrupt is generated during the program, the program address (P) at the time of the interrupt is stored at location 0040. The current Channel Status code is displayed in the A register before halting the program.

Address 1006 contains another EXC instruction which sends the Equipment Status code to the converter. This code makes the controller Status Reply available to the 160-A Computer. The 7600 instruction at address 1010 reads the 12-bit Status Reply code into the A register in the 160-A Computer. Logical Product instructions at 1011 and 1015 check the code for Ready and Write Enable signals.

The program starts at address 1000 with an EXC instruction. This transmits Connect Initiate code (6004) at address 1001 to the converter. The following Output instruction (7366) at address 1002 sends the Connect code at address 1202 to the tape controller. The 3000 Series Communication Module makes the connection and returns a Reply, or it returns a Reject if it cannot make the connection.

Another EXC instruction at 1020 transmits the Function Initiate code (address 1021) to the converter. The following Output instruction at address 1022 (7347) sends a code to the tape controller which sets control A to the BCD mode. A Clear Interrupt Lockout instruction at address 1024 again enables any interrupts to the 160-A Computer.

Instructions at addresses 1026, 1027 set control A in the tape controller to 556 BPI density.

Another EXC instruction at address 1030 sends the Write code (6040) to the converter. (A separate EXC instruction is needed since the converter cannot generate an Output Resume unless the code is preceded by an EXC instruction.) The Output instruction at address 1032 begins the Output operation, tape motion starts, and writing continues until all 100_g words have been written on tape. Another Clear Interrupt Lockout instruction (address 1036) enables any interrupts which may have occurred during the operation.

The program waits until the controller is Not Busy (1034-1043) and then continues at address 1046 with another EXC instruction which sends the Function Initiate code to the adapter. The Output instruction at address 1050 transmits the Rewind code (0010) found at address 1203 to the tape controller. After doing a clear interrupt lockout (address 1052), the program halts at address 1054.

SECTION B

3682-A SATELLITE COUPLER

CONTENTS

Functional Description	B-1	Switches and Indicators	B-6
Introduction	B-1	Programming and Information Transfer	B-7
Expanded Satellite System	B-3	Clear	B-8
Codes	B-3	Read/Write	B-8
Connect Code	B-4	Programming Example	B-11
Function Codes	B-5		
Status Codes	B-6		

FIGURES

B-1	Typical Configuration	B-1	B-6	Flow Chart: Information Exchange Between Two Computers Using the 3682 Coupler (Write: Division A; Read: Division B)	B-9
B-2	Block Diagram: 3682 Coupler	B-2			
B-3	Expanded Satellite System	B-3			
B-4	Function Codes	B-5			
B-5	3682 Coupler Switches and Indicators	B-6	B-7	Satellite System Configuration	B-12
			B-8	Programming Example	B-12

TABLES

B-1	Connect, Function, and Status Codes	B-3
-----	-------------------------------------	-----

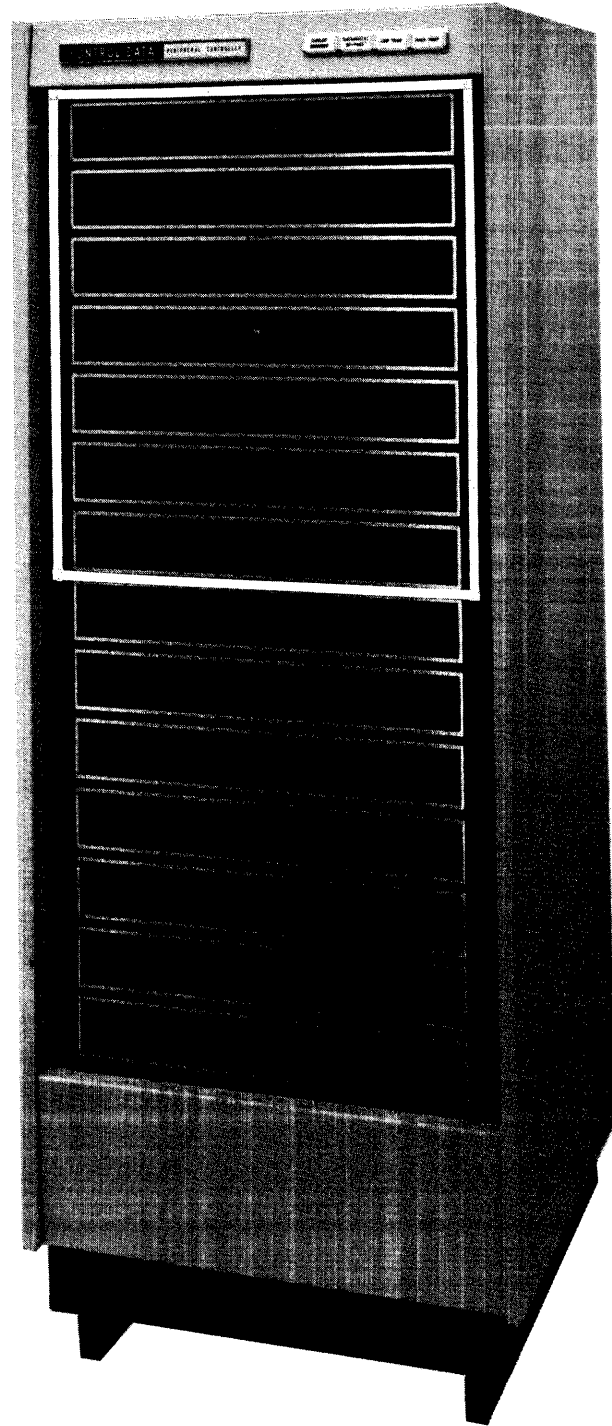

3682 SATELLITE COUPLER

3682-A SATELLITE* COUPLER

The CONTROL DATA* 3682 Satellite Coupler permits communication between two 3000 Series Computers or, when used in conjunction with a CONTROL DATA 3681 Data Channel Converter, between one 3000 Series Computer and a 160/160-A Computer. (See Figure B-1.)

FUNCTIONAL DESCRIPTION

INTRODUCTION

The 3682 Coupler acts as a data path between two 3000 Series data channels in two separate computer systems. To transfer information between the two data channels, one channel must perform a Write operation while the other channel executes a corresponding Read operation. Data transfer stops when either data channel terminates its Input/Output operation.

The coupler transfers 12-bit bytes directly between the two channels; there is no conversion or re-formatting of the data.

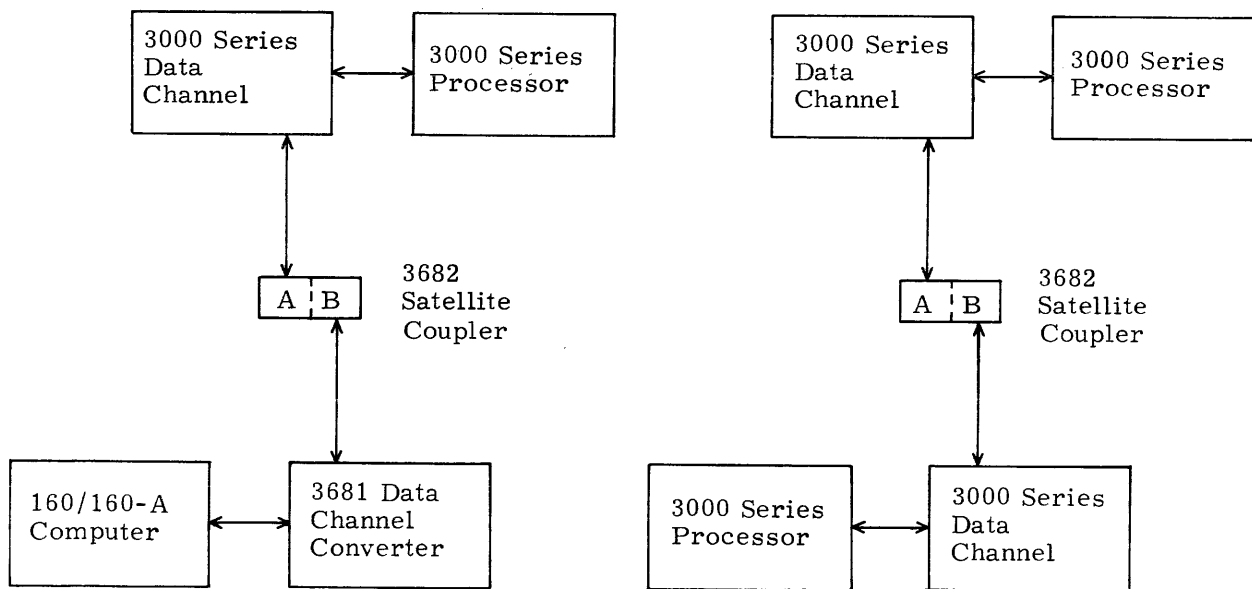

Figure B-1. Typical Configurations

* Registered trademark of Control Data Corporation

The 3682 Coupler may be considered as consisting of two divisions, A and B. Each division contains control logic, a 10-bit Interrupt Mask register, and input/output hardware. The two divisions share a common Flag register.

Bits in the Flag register may form logical products with corresponding bits in either Interrupt Mask register. When the logical product of corresponding bits is "1", an interrupt is sent to the computer which sets up the interrupt condition.

Minimum transfer time for one 48-bit word (4 12-bit bytes) is 1.6 microseconds when the coupler is used as a data link between two 3600 systems. Minimum transfer time for one 48-bit word when used as a data link between a 160/160-A Computer and a 3600 system is 60 microseconds.

The coupler is housed in a peripheral controller cabinet. A block diagram of the coupler is shown in Figure B-2.

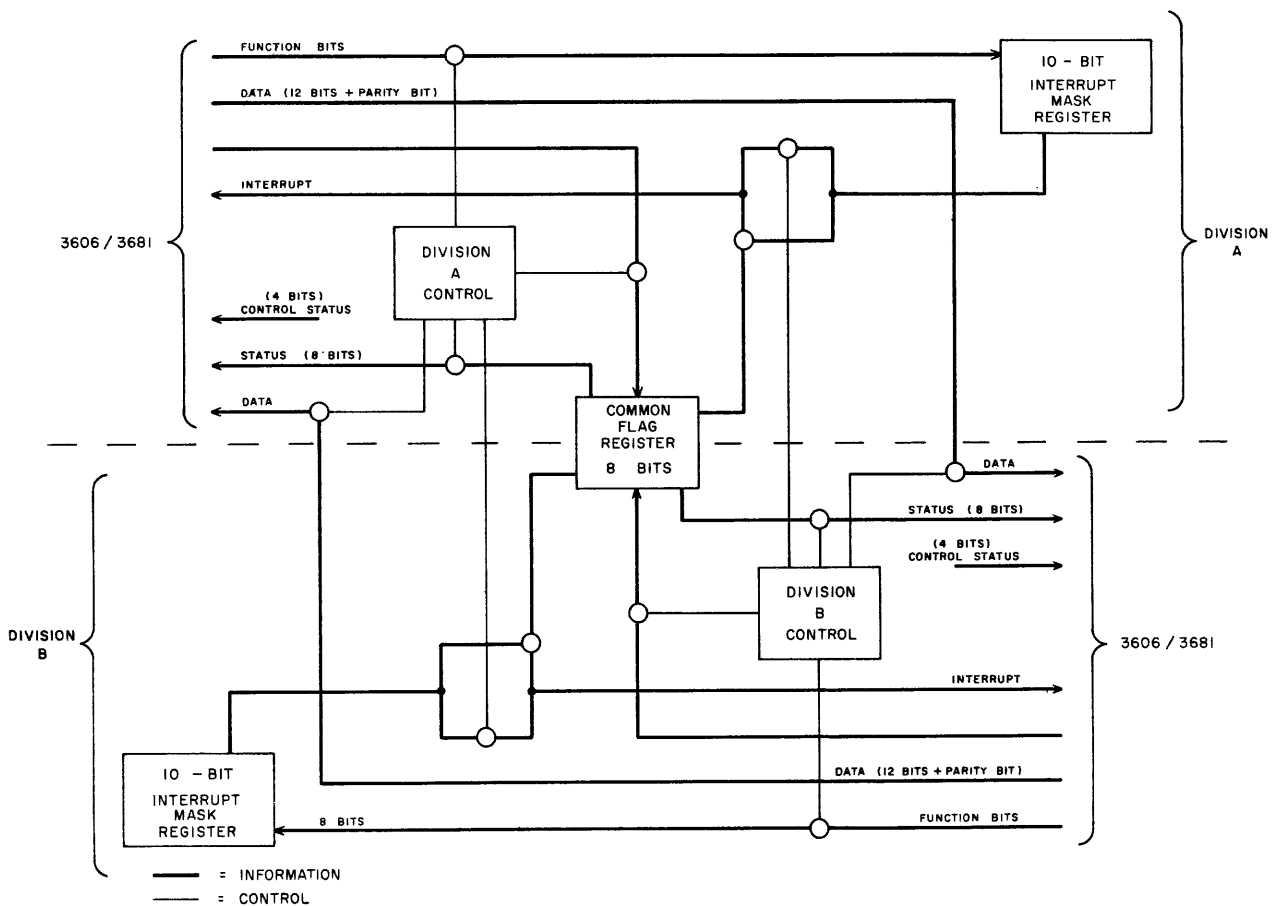

Figure B-2. Block Diagram: 3682 Coupler

EXPANDED SATELLITE SYSTEM

Figure B-3 shows an expanded Satellite system. A 3000 Series data channel may communicate with a total of eight 3000 Series external equipments. The 160-A Computer may also communicate via the 3681 Converter with a total of eight 3000 Series external equipments, such as the 3620 Tape Controller, the 3642 Card Punch, etc.

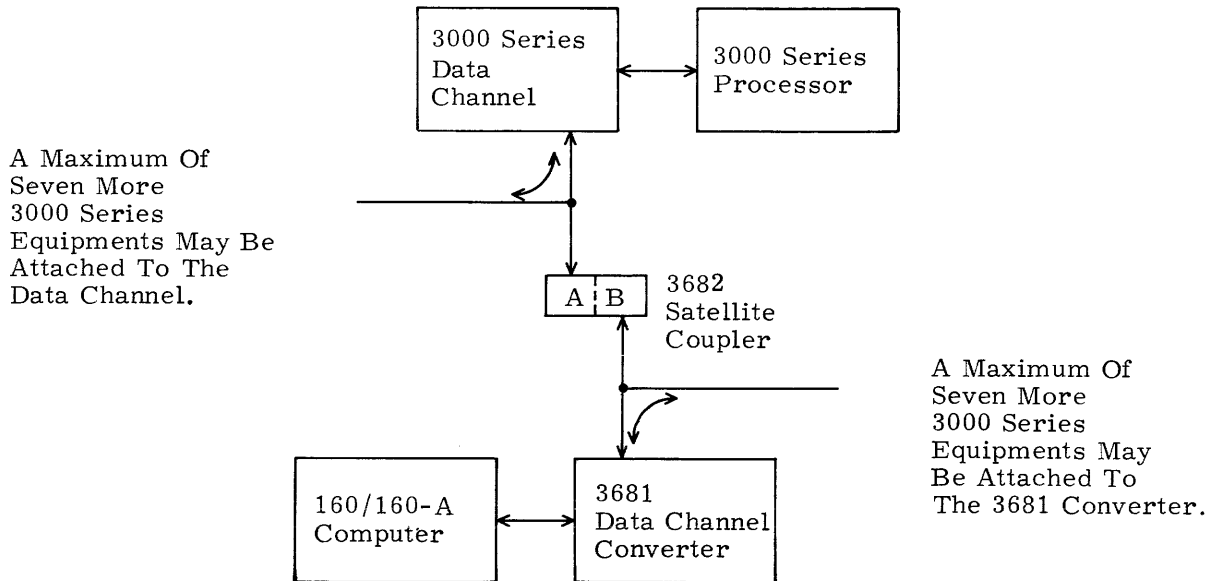

Figure B-3. Expanded Satellite System

CODES

All connections and operations are controlled by 12-bit Connect and Function codes in conjunction with the appropriate machine instruction. Status codes are constantly available while the equipment is connected. In all discussion of codes, bit 0 is in the rightmost position. (See Table B-1.)

TABLE B-1. CONNECT, FUNCTION, AND STATUS CODES

CONNECT	
Connect Coupler	N000*
FUNCTION	
Set Flags for "1" Bits in N**	01xxXX
Clear Flags for "1" Bits in N	10xxXX

* In Connect code, N refers to equipment number.

** In function code, N refers to lower 7 bits of the code.

TABLE B-1. CONNECT, FUNCTION, AND STATUS CODES (Cont'd)

FUNCTION (Cont'd)	
Set Interrupt Mask Register for "1" Bits in N	20xxXX
Clear Interrupt Mask Register for "1" Bits in N	40xxXX
Select Interrupt on Other Division in Abnormal Condition	0001
Release Interrupt on Other Division in Abnormal Condition	0002
Select Interrupt on Other Division Active	0004
Release Interrupt on Other Division Active	0010
STATUS	
Flag 0	XXX1
Flag 1	XXX2
Flag 2	XXX4
Flag 3	XX1X
Flag 4	XX2X
Flag 5	XX4X
Flag 6	X1XX
Flag 7	X2XX
Other Division, Computer Running (not necessarily connected)	X4XX
Other Division, Read	1XXX
Other Division, Write	2XXX
Other Division, Transmission Parity Error	4XXX

CONNECT CODE

Connect Coupler (N000)

After clearing common flags by a Power On Master Clear and division interrupts by Master Clears, each division must be connected.

Twelve-bit Connect codes are transmitted to the divisions of the 3682 Coupler by the computers desiring a communication path. The N portion of the Connect code from each computer must match the setting of the Equipment Number switch on its division of the coupler. (See the 3681 Converter section for information on generating a 12-bit Connect code when using the converter with a 160/160-A Computer.)

The order and time of connecting the divisions of the coupler is not critical, but each division must be connected before a communication path between computers is established.

A Reply is returned to the equipment connecting a division when the Connect operation is complete.

If a parity error occurs during transmission of the Connect code (odd parity on transmission, 12-bit code + 1 parity bit), the division does not connect and a Parity Error indicator on the computer lights. When a division is connected to a computer via a 3606 Data Channel or 3681 Converter, status bits are available on 12 status lines to the computer.

FUNCTION CODES

The 12-bit function code is divided into a 4-bit F portion and an 8-bit N portion. (See Figure B-4.) Each of the 8 bits in N has a corresponding flag (e. g., bit 5 in N corresponds to flag 5).

When a division of the 3682 Coupler has been connected, 12-bit function codes may set up certain operating conditions within the coupler. These conditions are:

Set Flags for "1" Bits in N (01xxXX)

This code sets all flags for which the corresponding bits are set in the N portion of the code.

Clear Flags for "1" Bits in N (10xxXX)

This code clears all flags for which the corresponding bits are set in the N portion of the code.

Set Interrupt Mask Register for "1" Bits in N (20xxXX)

This code sets all bits in the Interrupt Mask register for which the corresponding bits are set in the N portion of the code.

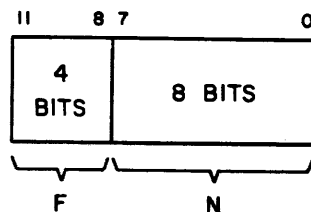

Figure B-4. Function Codes

Clear Interrupt Mask Register for "1" Bits in N (40xxXX)

This code clears all bits in the Interrupt Mask register for which the corresponding bits are set in the N portion of the code.

Select Interrupt on Other Division in Abnormal Condition (0001)

Release Interrupt on Other Division in Abnormal Condition (0002)

This code permits the equipment to send an Interrupt signal to the selecting computer if the other division computer is not running, if a parity error exists in the other division, or if both of the above exist. The selection or interrupt may be cleared by either a Master Clear or selecting the release (0002).

Select Interrupt on Other Division Active (0004)

Release Interrupt on Other Division Active (0010)

This code permits the equipment to send an Interrupt signal to the selecting computer if the other division has a Read or Write signal up. The selection or interrupt may be cleared by either a Master Clear or selecting the release (0010).

STATUS CODES

After a division is connected, it is desirable to check the status of the other division. This is done with Copy Status or Sense Status instructions.* Using the Status codes listed in Table B-1, it is possible to check flags, to check for Read or Write signals, to check for parity errors, and to check whether or not the other computer is running.

SWITCHES AND INDICATORS

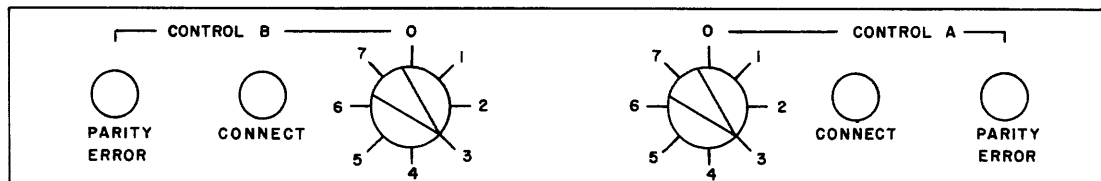

Figure B-5. 3682 Coupler Switches and Indicators

* See the individual system reference manuals for processing details.

EQUIPMENT NUMBER SWITCH

An eight-position Equipment Number switch is associated with each control (division). The setting of this switch (0 - 7) designates the Equipment Number of the control. It also determines on which of the eight interrupt lines the control sends an Interrupt signal to the data channel.

PARITY ERROR

A transmission Parity Error indicator lights if a parity error occurs during a Connect, Function, or Write operation. The indicator remains lighted until a Master Clear is applied to the division in which the parity error occurred.

CONNECT

A Connect indicator in a division lights when the division is connected to a data channel or a data channel converter. It remains lighted until the division is disconnected.

PROGRAMMING AND INFORMATION TRANSFER

The 3682 Coupler may be used with the 3681 Converter. See the section on the 3681 Converter for detailed programming information.

The order of events involved in programming the 3682 Coupler when used as a link between two 3000 Series data channels or between a 3681 Converter and one 3000 Series data channel is:

- 1) Clear
- 2) Connect
- 3) Check Status
- 4) Functions, Read/Write
- 5) Clear flags and interrupts when complete if they serve no further purpose

CLEAR

Three types of clear are used in the 3682 Coupler.

The type of clear needed at the end of a program involving the coupler depends on the specific situation, but the operator must clear flags and interrupts either at the end of a program or at the beginning of a new program.

Power On Master Clear

This clears all the flags when power is first applied to the coupler.

Master Clear

If the 3000 Series system is physically attached to a division of the coupler via a 3000 Series data channel, an External Master Clear from the 3000 Series system clears all selected interrupt conditions in that division. If the 160/160-A Computer is physically attached to a division of the coupler via a 3681 Converter, a Master Clear from the 160/160-A Computer clears all selected interrupt conditions in that division.

Function Clear

Selected flags and interrupts may also be cleared by a Function code, but the division of the coupler to be cleared must be connected before a function can be executed.

READ/WRITE

Information transfer takes place when one computer initiates a Write operation and the other computer initiates a corresponding Read. The exchange stops when (1) the data channel performing the Write operation stops transmitting data or (2) when the data channel conducting the Read operation stops accepting data. In the first case, the coupler sends an End of Record signal (Input Disconnect in the case of a 160-A Computer) to the data channel doing the Read to terminate the Read operation. In the second case, the data channel executing the Write operation cannot continue and waits indefinitely.

Figure B-6 is a flow chart of the sequence of events involved when the 3682 Coupler is used as a link between computers A and B. In this case, assume computer A is connected to Division A of the coupler via a 3606/3681;* assume computer B is connected

* Any 3000 Series data channel may be used.

Figure B-6 (Sheet 1 of 2). Flow Chart: Information Exchange Between Two Computers Using the 3682 Coupler (Write: Division A; Read: Division B)

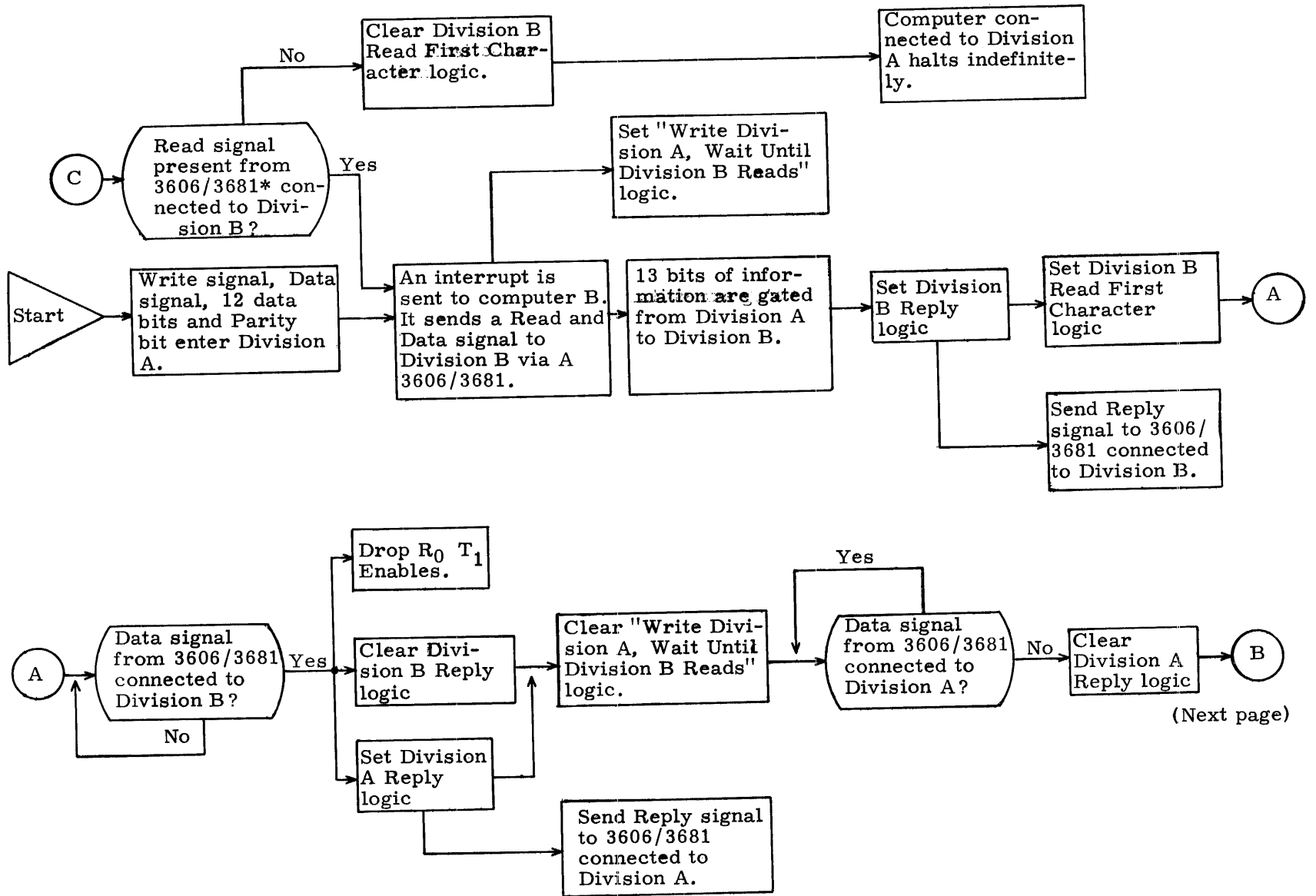

(Next page)

*Any 3000 Series Data Channel may be used.

Figure B-6 (Sheet 2 of 2). Flow Chart: Information Exchange Between Two Computers Using the 3682 Coupler (Write: Division A; Read: Division B)

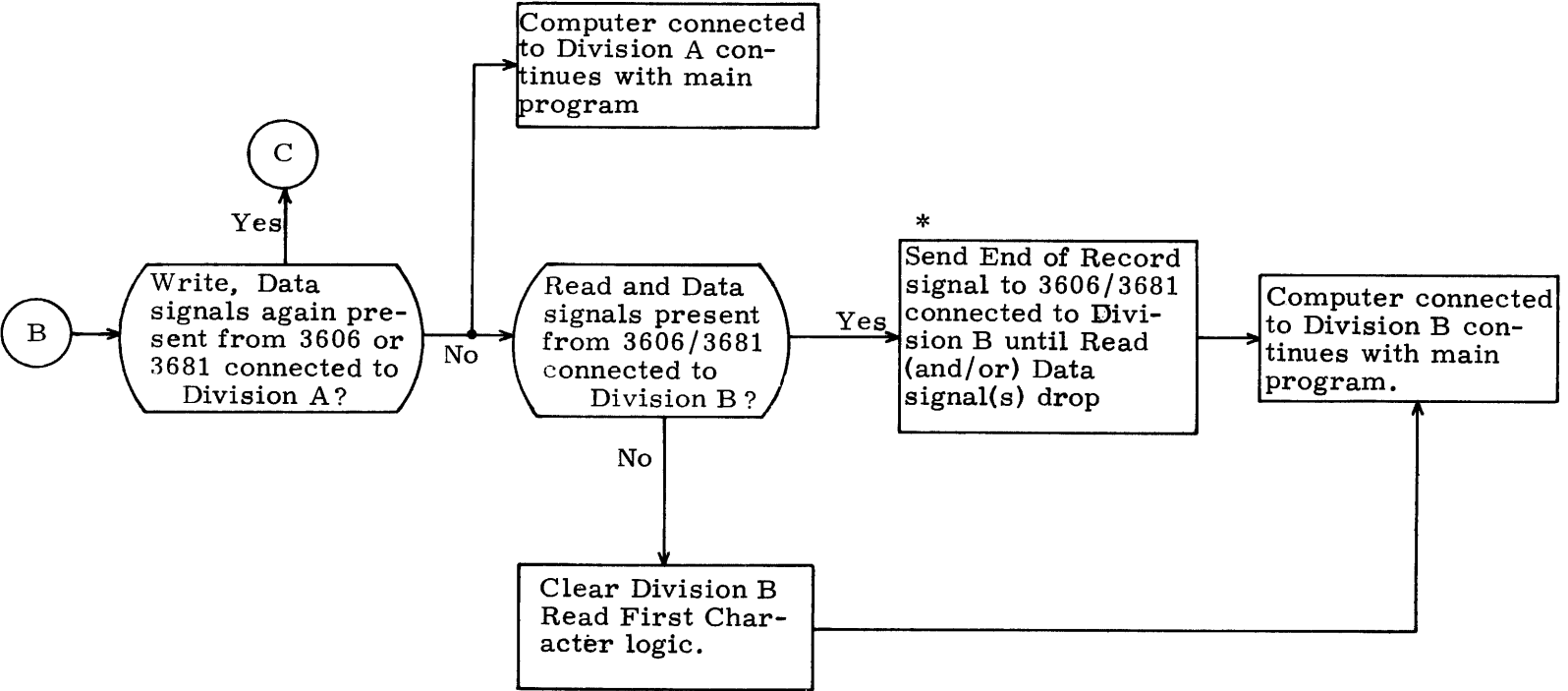

*The End of Record signal is sent to the computer doing the Read operation to indicate no more information is available.

to Division B of the coupler via a 3606/3681. Computer A is going to transfer information to computer B. Both computers are running.

When computer A reaches a certain point in its program, it begins a Write (Output) operation. Write and Data signals are sent to Division A. If the other division read/write logic in Division B is set, an interrupt is sent to the computer connected to Division B. Computer B enters an interrupt routine and clears this logic. Then computer B begins a Read operation. Read and Data signals are sent to Division B.

The operation continues as shown in the flow chart. Division B accepts the information from Division A and sends a Reply to its data channel. When the Data signal drops, the Reply drops, and Division A sends a Reply to its data channel.

The operation continues until: (1) Division A no longer receives Write and Data signals from its data channel, or (2) Division B no longer receives Read and Data signals from its data channel (Write and Data signals present in Division A). The flow chart indicates what happens when case (1) or case (2) occurs.

The sequence of events for a Read on Division A and Write on Division B operation is identical to Figure B-5 if the terms Division A and Division B are interchanged.

PROGRAMMING EXAMPLE

Problem: Transfer 100_8 words from the 3600 system to the 160-A Computer via the 3682 Coupler. Notify the 160-A Computer by bringing up a write line in Division A prior to the word transfer. (This interrupts the computer and it enters into a predetermined interrupt routine.) Refer to Figure B-7 for system configuration.

Initial Conditions:

- 1) The 3606 Data Channel is designated as channel 01.
- 2) The data channel is physically attached to Division A of the Coupler. Division A is set to accept Connect code 0000_8 .
- 3) The 160-A Computer is physically attached to the 3681 Converter. The converter is physically attached to the coupler, Division B. Division B is set to accept Connect code 1000_8 .
- 4) Both the 160-A computer and the 3600 system are running.

The 3600 System and 160-A Computer must be connected to their respective divisions of the 3682 Coupler prior to information transfer. In addition, the computer must have

Division B selected to interrupt the computer when the 3600 System brings up its write line. The 160-A Computer and 3600 System programs proceed according to Figure B-8.

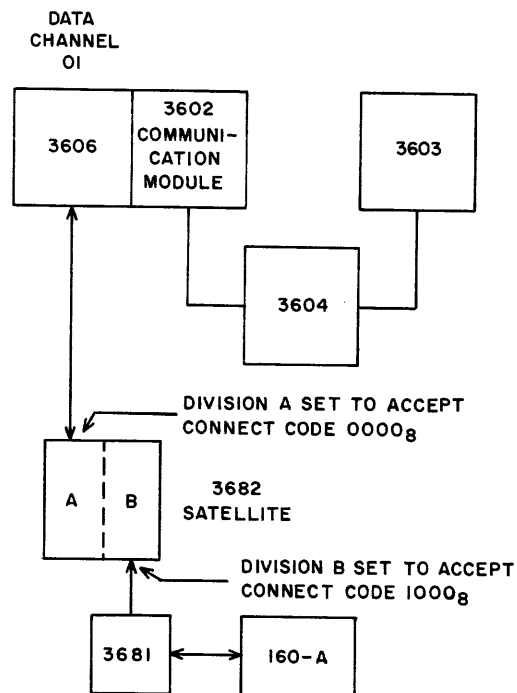

Figure B-7. Satellite System Configuration

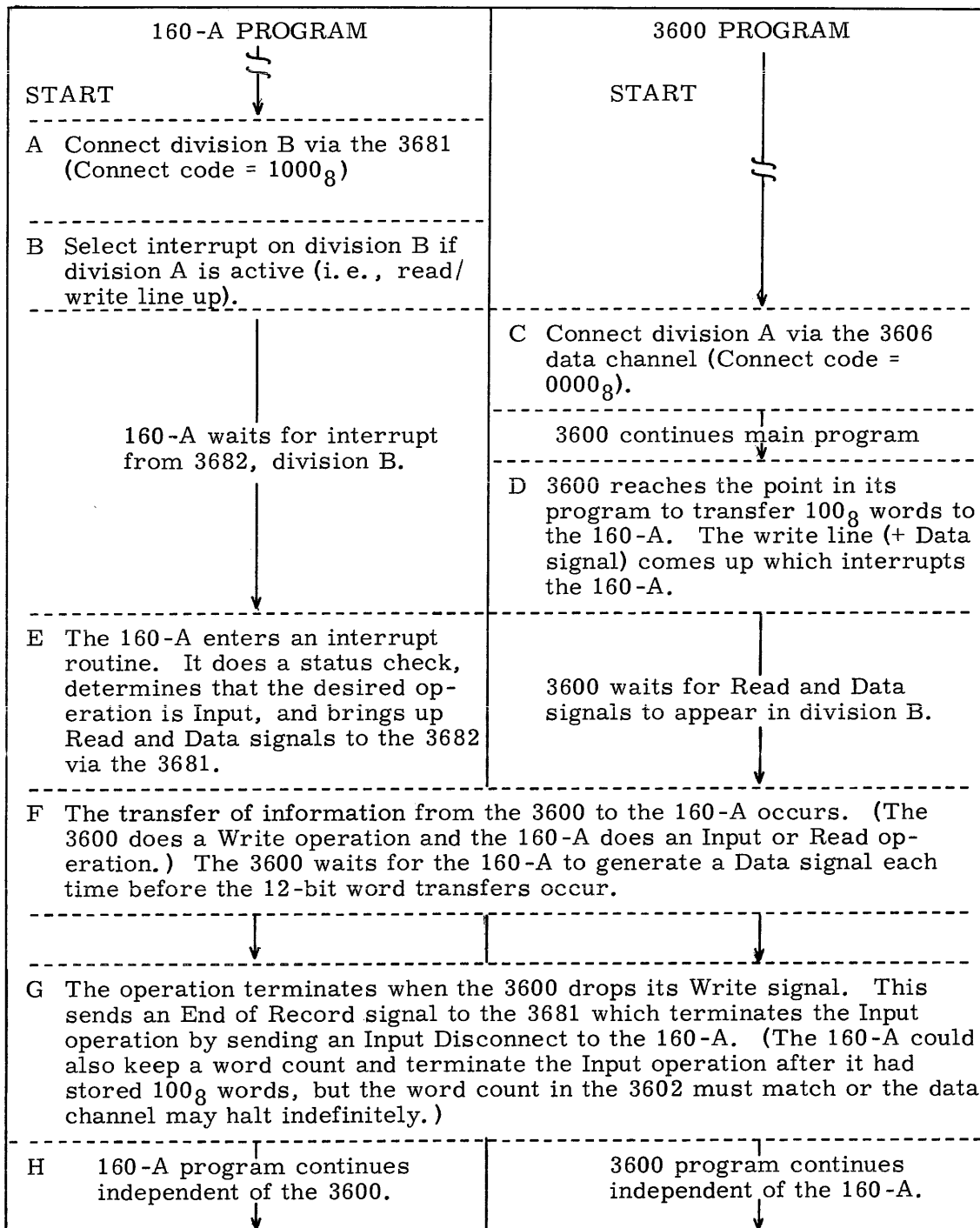

Figure B-8. Programming Example

COMMENT SHEET

MANUAL TITLE CONTROL DATA 3000 SERIES PERIPHERAL EQUIPMENT

Reference Manual, Volume 2

PUBLICATION NO. 60108800 REVISION _____

FROM: NAME: _____

BUSINESS
ADDRESS: _____

COMMENTS:

This form is not intended to be used as an order blank. Your evaluation of this manual will be welcomed by Control Data Corporation. Any errors, suggested additions or deletions, or general comments may be made below. Please include page number references and fill in publication revision level as shown by the last entry on the Record of Revision page at the front of the manual. Customer engineers are urged to use the TAR.

CUT ALONG LINE

FORM CA231 REV. 1-67

NO POSTAGE STAMP NECESSARY IF MAILED IN U. S. A.

FOLD ON DOTTED LINES AND STAPLE

STAPLE

STAPLE

FOLD

FOLD

FIRST CLASS
PERMIT NO. 8241
MINNEAPOLIS, MINN.

BUSINESS REPLY MAIL
NO POSTAGE STAMP NECESSARY IF MAILED IN U.S.A.

POSTAGE WILL BE PAID BY
CONTROL DATA CORPORATION
8100 34TH AVENUE SOUTH
MINNEAPOLIS, MINNESOTA 55440

ATTN: TECHNICAL PUBLICATIONS DEPT.
PLANT TWO

FOLD

FOLD

CUT ALONG LINE





CORPORATE HEADQUARTERS, 8100 34th AVE. SO., MINNEAPOLIS, MINN. 55440
SALES OFFICES AND SERVICE CENTERS IN MAJOR CITIES THROUGHOUT THE WORLD