

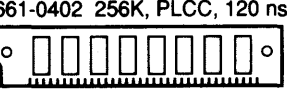

34380052
© 1985 APPLE
1803 CDP

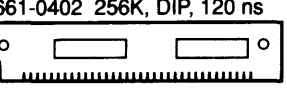
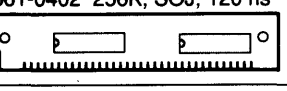
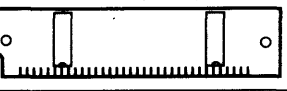
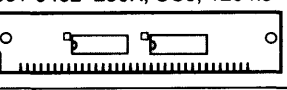

Apple Service
Technical Procedures
Macintosh Family
Volume One

DRAM SIMMs for CPUs Service Exchange Modules	Macintosh Computers													
	Plus	Classic	Classic II	SE	SE/30	LC	II	IIx	IIfx	IIsi	IIcx	IIci	Quadra 700	Quadra 900
661-0402 256K, PLCC, 120 ns 	Apple	Apple		Apple	Apple		Apple	Apple			Apple			
661-0402 256K, DIP, 120 ns 	Apple	Apple		Apple	Apple		Apple	Apple			Apple			
661-0402 256K, SOJ, 120 ns 	Apple	Apple		Apple	Apple		Apple	Apple			Apple			
661-0402 256K, SOJ, 120 ns 	Apple	Apple		Apple	Apple		Apple	Apple			Apple			
661-0402 256K, SOJ, 120 ns 	Apple	Apple		Apple	Apple		Apple	Apple			Apple			
661-0494 256K, DIP, 120 ns 	Apple	Apple		1	2		Apple	Apple			Apple			
661-0519 256K, SOJ, 80 ns 	Apple	Apple		Apple	Apple		Apple	Apple		Apple	Apple	Apple	Apple	Apple
661-0646 512K, SOJ, 80 ns 										Apple	Apple			
Slowest Acceptable DRAM speed (ns)	150	120	100	150	120	100	120	120	80	100	120	80	80	80

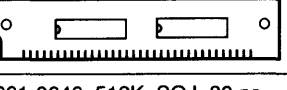
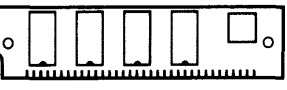
1 Can be installed only in SIMM positions 3 and 4 because of space constraints.

2 Can be installed only in SIMM Bank A because of space constraints.

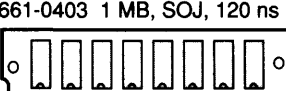
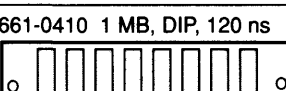
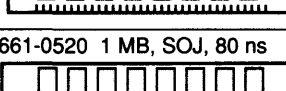
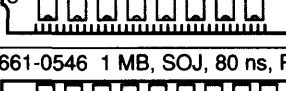
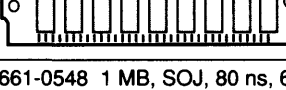
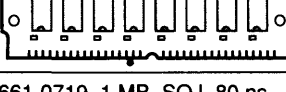
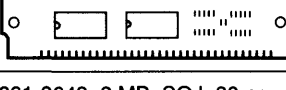
DRAM SIMMs for CPUs Service Exchange Modules	Macintosh Computers													
	Plus	Classic	Classic II	SE	SE/30	LC	II	IIx	IIfx	IIsi	IIcx	IIci	Quadra 700	Quadra 900
661-0403 1 MB, SOJ, 120 ns 	Apple	Apple		Apple	Apple		Apple	Apple			Apple			
661-0410 1 MB, DIP, 120 ns 	Apple			1	2		Apple	Apple			Apple			
661-0520 1 MB, SOJ, 80 ns 	Apple	Apple		Apple	Apple	Apple	Apple	Apple		Apple	Apple	Apple	Apple	Apple
661-0546 1 MB, SOJ, 80 ns, Parity 	3	3	3	3	3	3	3	3		3	3	Apple	3	3
661-0548 1 MB, SOJ, 80 ns, 64-Pin 										Apple				
661-0719 1 MB, SOJ, 80 ns 		Apple		Apple	Apple	Apple				Apple	Apple	Apple	Apple	Apple
661-0643 2 MB, SOJ, 80 ns 		Apple		Apple		Apple				Apple	Apple			
Slowest Acceptable DRAM speed (ns)	150	120	100	150	120	100	120	120	80	100	120	80	80	80





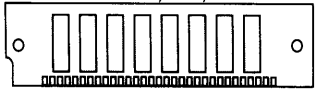
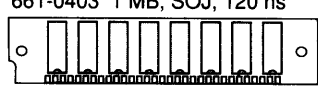

3 The SIMM is compatible with the CPU, but the CPU does not use the parity feature of this SIMM.

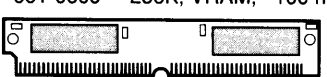
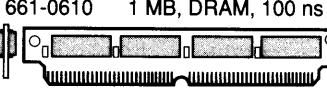
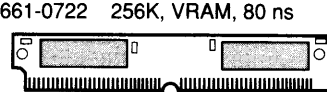
See other side of Quick Reference: SIMM Compatibility for DRAM SIMMs in LaserWriter, Video Display SIMMs, and Finished Goods Only.

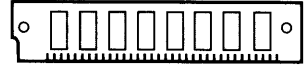
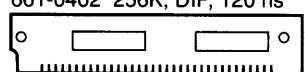
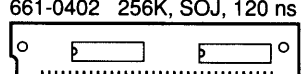
DRAM SIMMs for CPUs Finished Goods Only	Macintosh Computers													
	Plus	Classic	Classic II	SE	SE/30	LC	II	IIx	IIfx	IIsi	IIcx	IIci	Quadra 700	Quadra 900
661-0402 256K, DIP, 120 ns 	Apple			1										
661-0403 1 MB, SOJ, 120 ns 					Apple			Apple						
Slowest DRAM speed required (ns)	150	120	100	150	120	100	120	120	80	100	120	80	80	80

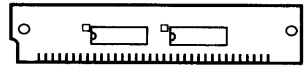
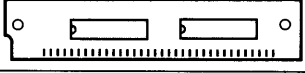

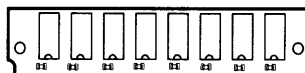
- 1 Can be installed only in SIMM positions 3 and 4 because of space constraints.
- 4 Apple substitutes a compatible service exchange module for finished-goods SIMMs. You will not receive a finished-goods SIMM as a service exchange module.

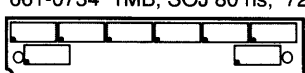
Video Display SIMMs	Macintosh Computers										Cards					
	Plus	Classic	Classic II	SE	SE/30	LC	II	IIx	IIfx	IIsi	IIcx	IIci	Quadra 700	Quadra 900	4+8	8+24 GC
661-0649 512K, VRAM, 100 ns 						Apple										
661-0609 256K, VRAM, 100 ns 						Apple							Apple	Apple	Apple	
661-0610 1 MB, DRAM, 100 ns 																Apple
661-0722 256K, VRAM, 80 ns 						Apple							Apple	Apple	Apple	

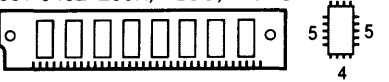
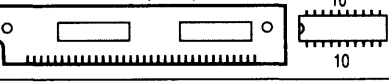
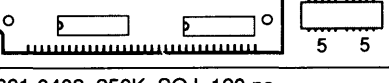
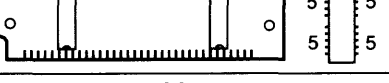
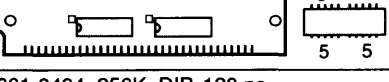
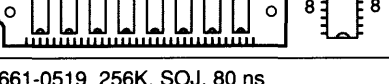
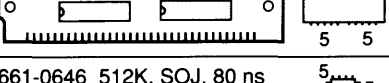
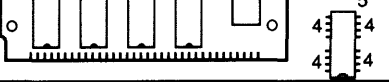
DRAM SIMMs in LaserWriter Printers	LaserWriter II NTX/SC	LaserWriter IIif/IIg	Personal LaserWriter NT	Personal LaserWriter SC	Personal LaserWriter NTR
	661-0402 256K, PLCC, 120 ns 		Apple		Apple
661-0402 256K, DIP, 120 ns 		Apple		Apple	
661-0402 256K, SOJ, 120 ns 		Apple		Apple	
661-0402 256K, SOJ, 120 ns 		Apple		Apple	
661-0402 256K, SOJ, 120 ns 		Apple		Apple	
661-0519 256K, DRAM, 80 ns 		Apple			
661-0520 1MB, DRAM, 80 ns 		Apple	Apple		
661-0441 256K, DRAM, 120 ns 	Apple				
661-0445 1MB, DRAM, 120 ns 	Apple				
661-0734 1MB, SOJ 80 ns, 72-Pin 					Apple

DRAM SIMMs for CPUs Service Exchange Modules	Macintosh Computers													
	Plus	Classic	Classic II	SE	SE/30	LC	II	IIx	IIfx	IIsi	IIcx	IIci	Quadra 700	Quadra 900
661-0402 256K, PLCC, 120 ns 	Apple	Apple		Apple	Apple		Apple	Apple			Apple			
661-0402 256K, DIP, 120 ns 	Apple	Apple		Apple	Apple		Apple	Apple			Apple			
661-0402 256K, SOJ, 120 ns 	Apple	Apple		Apple	Apple		Apple	Apple			Apple			
661-0402 256K, SOJ, 120 ns 	Apple	Apple		Apple	Apple		Apple	Apple			Apple			
661-0402 256K, SOJ, 120 ns 	Apple	Apple		Apple	Apple		Apple	Apple			Apple			
661-0494 256K, DIP, 120 ns 	Apple	Apple		1	2		Apple	Apple			Apple			
661-0519 256K, SOJ, 80 ns 	Apple	Apple		Apple	Apple		Apple	Apple		Apple	Apple	Apple		
661-0646 512K, SOJ, 80 ns 										Apple	Apple			
Slowest Acceptable DRAM speed (ns)	150	120	100	150	120	100	120	120	80	100	120	80	80	80

- 1 Can be installed only in SIMM positions 3 and 4 because of space constraints.
 2 Can be installed only in SIMM Bank A because of space constraints.

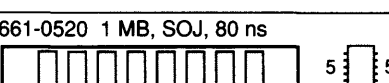
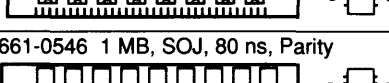
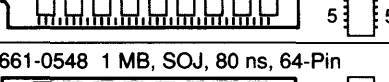
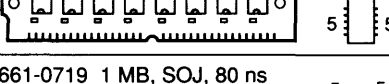
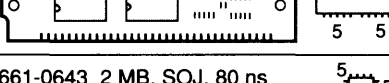
DRAM SIMMs for CPUs Service Exchange Modules	Macintosh Computers													
	Plus	Classic	Classic II	SE	SE/30	LC	II	IIx	IIfx	IIsi	IIcx	IIci	Quadra 700	Quadra 900
661-0403 1 MB, SOJ, 120 ns 	Apple	Apple		Apple	Apple		Apple	Apple			Apple			
661-0410 1 MB, DIP, 120 ns 		Apple		1	2		Apple	Apple			Apple			
661-0520 1 MB, SOJ, 80 ns 	Apple	Apple	Apple	Apple	Apple	Apple	Apple	Apple			Apple	Apple	Apple	Apple
661-0546 1 MB, SOJ, 80 ns, Parity 	3	3	3	3	3	3	3	3			3	3	3	3
661-0548 1 MB, SOJ, 80 ns, 64-Pin 											Apple			
661-0719 1 MB, SOJ, 80 ns 		Apple		Apple	Apple	Apple				Apple	Apple	Apple	Apple	Apple
661-0643 2 MB, SOJ, 80 ns 		Apple		Apple		Apple				Apple	Apple			
Slowest Acceptable DRAM speed (ns)	150	120	100	150	120	100	120	120	80	100	120	80	80	80

- 3 The SIMM is compatible with the CPU, but the CPU does not use the parity feature of this SIMM.
 See other side of Quick Reference: SIMM Compatibility for DRAM SIMMs in LaserWriter, Video Display SIMMs, and Finished Goods Only.

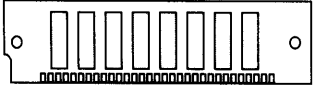
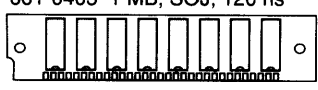
DRAM SIMMs for CPUs Finished Goods Only	Macintosh Computers													
	Plus	Classic	Classic II	SE	SE/30	LC	II	IIx	IIfx	IIsi	IIcx	IIci	Quadra 700	Quadra 900
661-0402 256K, DIP, 120 ns 	Apple			1										
661-0403 1 MB, SOJ, 120 ns 					Apple			Apple						
Slowest DRAM speed required (ns)	150	120	100	150	120	100	120	120	80	100	120	80	80	80

- 1 Can be installed only in SIMM positions 3 and 4 because of space constraints.
- 4 Apple substitutes a compatible service exchange module for finished-goods SIMMs. You will not receive a finished-goods SIMM as a service exchange module.

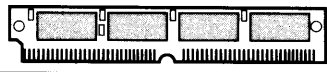
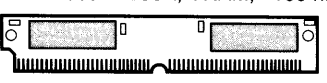
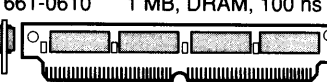
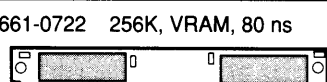
Video Display SIMMs	Macintosh Computers										Cards					
	Plus	Classic	Classic II	SE	SE/30	LC	II	IIx	IIfx	IIsi	IIcx	IIci	Quadra 700	Quadra 900	4-8	8-24 GC
661-0649 512K, VRAM, 100 ns 						Apple										
661-0609 256K, VRAM, 100 ns 						Apple							Apple	Apple	Apple	
661-0610 1 MB, DRAM, 100 ns 																Apple
661-0722 256K, VRAM, 80 ns 						Apple							Apple	Apple	Apple	

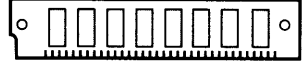
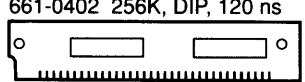
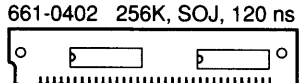
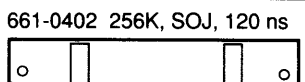
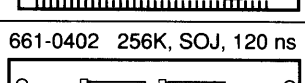
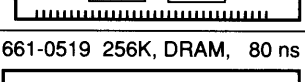
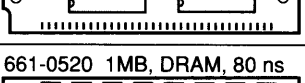
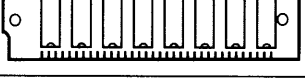
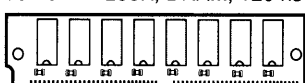
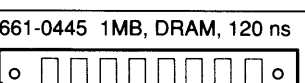
DRAM SIMMs in LaserWriter Printers	LaserWriter II NTX/SC	LaserWriter III/IIg	Personal LaserWriter NT	Personal LaserWriter SC	Personal LaserWriter NTR
	661-0402 256K, PLCC, 120 ns 		Apple		Apple
661-0402 256K, DIP, 120 ns 		Apple		Apple	
661-0402 256K, SOJ, 120 ns 		Apple		Apple	
661-0402 256K, SOJ, 120 ns 		Apple		Apple	
661-0402 256K, SOJ, 120 ns 		Apple		Apple	
661-0519 256K, DRAM, 80 ns 		Apple			
661-0520 1MB, DRAM, 80 ns 		Apple	Apple		
661-0441 256K, DRAM, 120 ns 	Apple				
661-0445 1MB, DRAM, 120 ns 	Apple				
661-0734 1MB, SOJ 80 ns, 72-Pin 					Apple

Apple Technical Procedures

Macintosh Family
Volume One

Table of Contents

	--Title page (contains build date)	—
Macintosh / Macintosh Plus	--Table of Contents	05/90
	--Basics	02/87
	(except pages 1.1-1.8)	03/90
	--Take-Apart	02/87
	(except page 2.14)	02/89
	(except pages 2.1-2.7, 2.9, 2.12, 2.15-2.17)	03/90
	(except pages 2.1, 2.19, 2.20)	05/90
	(except page 2.13)	03/91
	(except page 2.18)	01/92
	--Diagnostics	02/87
	(except page 3.17)	03/89
	(except page 3.11)	09/89
	--Troubleshooting	02/87
	(except pages 4.2, 4.5)	09/88
	(except pages 4.1, 4.4-4.7)	09/89
	(except page 4.9)	03/91
	(except page 4.8)	11/91
	--Adjustments	02/87
	(except pages 5.1, 5.7, 5.9)	07/89
	(except page 5.8)	11/89
	(except pages 5.3-5.6)	05/91
	--Additional Procedures	02/87
	(except pages 6.22, 6.25)	10/88
(except page 6.6)	11/88	
(except page 6.19)	09/88	
(except page 6.20)	07/87	
(except page 6.21)	07/89	
(except pages 6.23, 6.24)	01/90	
(except pages 6.1-6.5, 6.7-6.16)	05/90	
--Illustrated Parts List	04/87	
(except pages 7.1, 7.18, 7.19)	10/88	
(except pages 7.3, 7.5, 7.9)	11/89	
(except page 7.13)	08/87	
(except page 7.15)	03/92	

...Continued on next page

Macintosh /	(except page 7.17)	02/89
Macintosh Plus	(except page 7.14)	10/90
(Continued)	(except page 7.15)	08/91
	(except pages 7.6, 7.7)	12/91
Macintosh SE and	--Table of Contents	06/91
Macintosh SE/30	--Basics	02/89
	(except pages 1.2-1.15)	08/89
	(except pages 1.1, 1.16)	03/90
	--Take-Apart	08/89
	(except pages 2.1, 2.30-2.48)	06/91
	(except pages 2.2, 2.5-2.7)	03/90
	(except pages 2.31-2.33)	08/91
	(except pages 2.37, 2.41)	01/92
	--Diagnostics	08/89
	(except pages 4.18, 4.19)	09/89
	(except page 4.8)	05/90
	--Troubleshooting	01/89
	(except pages 5.1, 5.3, 5.12)	03/89
	(except pages 5.7, 5.13)	08/89
	--Additional Procedures	01/89
	(except pages 6.1-6.7)	11/90
	(except pages 6.8, 6.9)	01/90
	(except pages 6.29-6.31)	08/89
	(except pages 6.10, 6.15, 6.16, 6.19, 6.21)	07/89
	(except pages 6.26-6.28)	04/89
	--Illustrated Parts List	02/89
	(except page IPL.1)	11/90
	(except pages IPL.6, IPL.7, IPL.9)	08/89
	(except page IPL.10)	11/89
	(except page IPL.16)	06/89
	(except pages IPL.21, IPL.23, IPL.25, IPL.30, IPL.31)	02/89
	(except page IPL.19)	10/91
	(except pages IPL.2, IPL.3)	12/91
	(except page IPL.17)	01/92
	(except pages IPL.11, IPL.13)	03/92
Macintosh	--Table of Contents	10/91
Classic and	--Basics	10/91
Classic II	--Take-Apart	10/91
	(except pages 2.23, 2.29)	01/92
	(except page 2.21)	03/92
	--Adjustments	10/91
	(except pages 3.1-3.3, 3.5, 3.7)	03/92
	--Diagnostics	10/91
	(except pages 4.1, 4.2)	03/92

--Troubleshooting	10/91
(except pages 5.3, 5.4)	03/92
--Additional Procedures	10/91
(except page 6.2)	11/91
--Illustrated Parts List	10/91
(except page IPL.5-IPL.7)	12/91

(

(

(

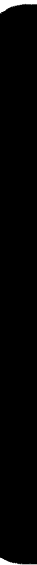



Macintosh and Macintosh Plus

Technical Procedures

□ TABLE OF CONTENTS

Section 1 – Basics	1.2	Macintosh and Macintosh Plus—Differences
	1.3	Memory
	1.3	Disk Capacity
	1.3	Keyboard
	1.3	Interfaces
	1.3	Internal Connections
	1.4	Theory of Operation Overview
	1.4	Introduction
	1.4	Modules and Functions
	1.8	Keyboard and Keypress Identification
Section 2 – Take-Apart	2.3	Electrostatic Discharge Prevention
	2.3	Cover
	2.6	Discharging the Cathode-Ray Tube (CRT)
	2.6	Discharge Procedure
	2.7	Anode Cap
	2.9	Power/Sweep Board
	2.12	Logic Board
	2.15	Cathode-Ray Tube (CRT)
	2.17	Internal Disk Drive
	2.19	Chassis
2.20	Keyboard	
Section 3 – Diagnostics	3.2	Introduction
	3.2	MacTest
	3.2	How to Use It
	3.3	Things to Remember
	3.5	Backup Procedure
	3.10	Running MacTest
	3.10	Materials Required
	3.11	Pull-Down Menus and Icons
	3.12	512K
	3.12	Select Test
3.14	Options	
3.15	Apple	

...Continued on next page

Section 3 – Diagnostics (continued)	3.16	Miscellaneous Icons
	3.16	Running the Diagnostic
	3.19	Error Codes
Section 4 – Troubleshooting	4.2	Introduction
	4.2	General Information
	4.2	Before You Start
	4.2	How to Use the Symptom Chart
	4.2	Exchanging the Logic Board
	4.2	Exchanging the Power/Sweep Board
	4.3	Things to Remember
	4.4	Symptom Chart
	4.4	Video Problems
	4.5	Drive Problems
	4.7	Peripheral Problems
	4.8	Miscellaneous Problems
Section 5 – Adjustments	5.2	Power/Sweep Voltage Adjustment
	5.2	Introduction
	5.2	Materials Required
	5.3	Voltage Adjustment
	5.5	Yoke Adjustments
	5.5	Introduction
	5.5	Materials Required
	5.5	Adjustment Procedures
	5.8	Video Adjustments
	5.8	Introduction
	5.8	Materials Required
5.9	Adjustment Procedures	
Section 6 – Additional Procedures	6.2	Macintosh Plus Kits
	6.2	Things to Remember
	6.3	Disk Drive and Logic Board Kits
	6.4	Macintosh Plus Disk Drive Kit
	6.7	Macintosh Plus Logic Board Kit
	6.8	Special Problems
	6.8	Alternate Chassis Screw Sizes
	6.9	800K Drive Exchange Compatibility
	6.9	800K Disk Ejection Problems
	6.13	Logic Board ROM Upgrade and 400K Drives
	6.14	Macintosh Plus RAM Upgrades
	6.14	Logic Board Configurations
	6.16	ROM Version Compatibility
6.16	ROM Upgrades for Enhanced Macintosh Systems	
6.16	Replacing 512K Logic Boards	

**Section 7 –
Illustrated
Parts List**

- 7.3 Macintosh External Housing (Figure 1)
- 7.5 Macintosh Plus Chassis and Power Supply
(Figure 2)
- 7.7 Macintosh Exploded View (Figure 3)
- 7.9 Macintosh Keyboard Assembly (Figure 4)
- 7.11 Macintosh Numeric Keypad Assembly (Figure 5)
- 7.13 Macintosh Plus Rear Housing (Figure 6)
- 7.15 Macintosh Plus—Exploded View (Figure 7)
- 7.17 Macintosh Plus Keyboard Assembly (Figure 8)
- 7.19 Service Packaging, 800K/1.4 MB Drives
(Figure 9)

©Apple Computer, Inc., 1985-1990. No portion of this document may be reproduced in any form without the written permission of Apple Computer, Inc.

MacTest, FDHD, and SuperDrive are trademarks of Apple Computer, Inc.

Macintosh, Apple, and the Apple logo are registered trademarks of Apple Computer, Inc.

(

(

(

Macintosh and Macintosh Plus

Section 1 – Basics

□ CONTENTS

1.2	Macintosh and Macintosh Plus—Differences
1.3	Memory
1.3	Disk Capacity
1.3	Keyboard
1.3	Interfaces
1.3	Internal Connections
1.4	Theory of Operation Overview
1.4	Introduction
1.4	Modules and Functions
1.8	Keyboard and Keypress Identification

□ MACINTOSH AND MACINTOSH PLUS — DIFFERENCES

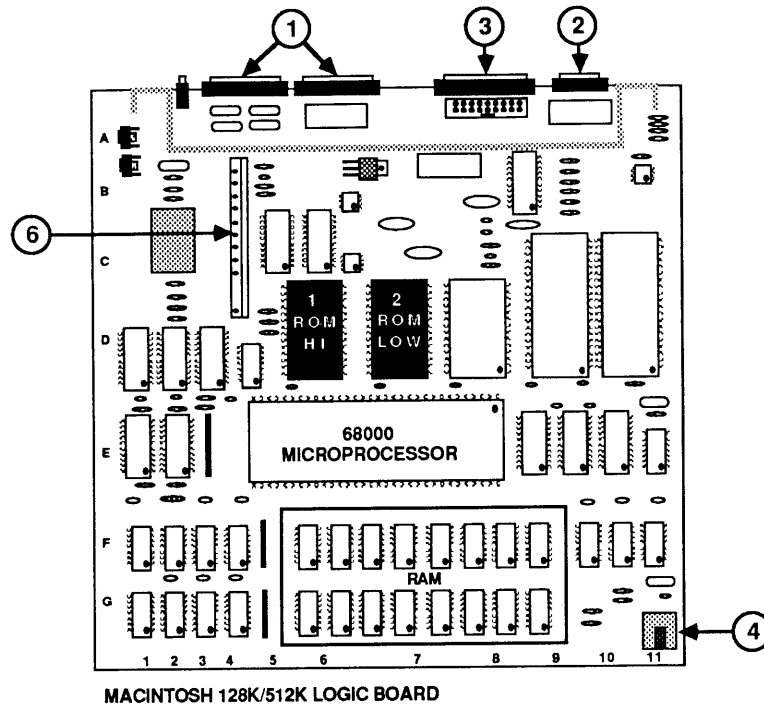

FIGURE 1

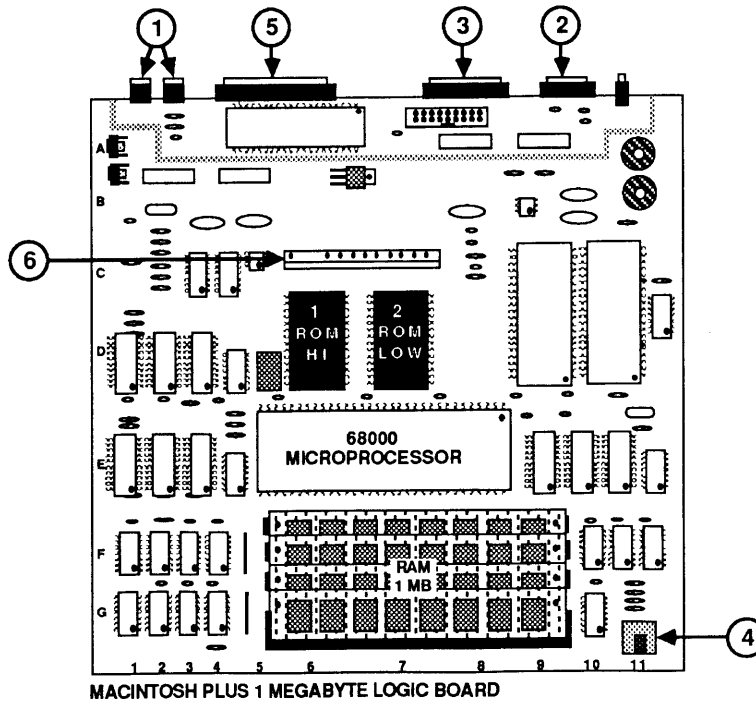

FIGURE 2

Memory

Macintosh

128K or 512K bytes RAM
64K bytes ROM

Macintosh Plus

1 MB RAM
128K ROM
256 bytes of
user-selectable
parameter memory

Disk Capacity

Macintosh

400K bytes per disk
single-sided

Macintosh Plus

800K bytes per disk
double-sided

Keyboard

Macintosh

58 key, software mapped

Macintosh Plus

78 key, software
mapped, with
built-in numeric
keypad and
direction keys

Interfaces

The numbers at the left of the list below correspond to the locations on both Figure 1 (Macintosh) and Figure 2 (Macintosh Plus) unless otherwise noted.

- # 1 Two RS-232/RS-422 serial ports
Macintosh uses DB-9 connectors
Macintosh Plus uses 8-pin DIN connectors
- # 2 Mouse interface
- # 3 External disk interface
- # 4 Synchronous serial keyboard bus

Macintosh Plus only (Figure 2)

- # 5 Small Computer System Interface (SCSI) port:
an industry-standard interface that provides
extremely high-speed access to hard disks, tape
backup systems, and other mass storage devices.

Internal Connections

The connector that runs from the power/sweep board to the logic board has been moved for the Macintosh Plus, as shown in Figures 1 and 2, #6.

□ THEORY OF OPERATION OVERVIEW

Introduction

Troubleshooting can be approached in many different ways. Apple recommends two methods in particular: logical troubleshooting and module swapping in a particular order for a particular symptom. Most troubleshooting charts in *Apple Service Technical Procedures* manuals are based upon the module-swapping method, but you can often save repair time by using logical troubleshooting before you start swapping.

Logical troubleshooting involves knowing the function of each module in the machine, and using that knowledge to narrow your search for the problem. This section will give you the information necessary to perform logical troubleshooting of the Macintosh and Macintosh Plus. The information here includes a description of each module in the Macintosh and Macintosh Plus and the various functions it performs. (For definitions of basic terms, refer to Section 4, Simplified Overview of a Microcomputer System, under the *You Oughta Know* tab.)

Unless otherwise noted, all information included here is the same for the Macintosh and Macintosh Plus.

Modules and Functions

Macintosh modules and their functions are given below:

Main Logic Board

The Macintosh main logic board (Figure 3) is the heart of the system. It contains the components described below. A number after an IC in the descriptions that follow corresponds to a number in the figure to the left (indicating its general location on the logic board).

The CPU, or 68000 microprocessor, gets instructions from memory, translates them, and carries them out. It communicates with all components on the logic board.

The RAM, or storage capability, varies. The Macintosh can have 128K or 512K. The Macintosh Plus has 1 megabyte of RAM installed on SIMM modules, which are mounted on the logic board.

The ROMs (1 is HI, 2 is LO—see Figure 3) contain the operating code for the 68000. The Macintosh ROMs and the Macintosh Plus ROMs are different. Refer to Section 6, Additional Procedures, for specifics.

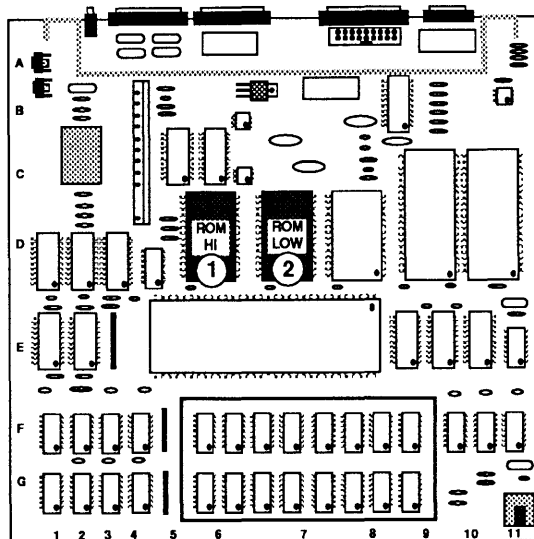

FIGURE 3

The IWM, or "Integrated Woz Machine" (named after Steve Wozniak), is a self-contained disk controller card on one IC. This IC supports both the internal and external disk drives.

The SCC, or serial communications controller, handles the information received and sent from the two serial ports on the rear of the machine. The Macintosh has two nine-pin serial ports. The Macintosh Plus has two eight-pin DIN connectors.

The VIA, or versatile interface adapter, is a dual-port parallel interface. This IC converts serial data (from input devices) to parallel data, so that the logic board can interpret the information correctly. It provides an interface for the mouse and the keyboard.

The PALs, or programmable array logic (customized ICs), replace from five to ten ICs. They perform various control and synchronizing functions for the rest of the main logic board.

The oscillator (timing device), generates the master clock pulse. The master clock pulse is broken down into various timing clocks needed by the ICs on the main logic board.

Power/Sweep Board

The power/sweep board (Figure 4) is divided into two sections, described below.

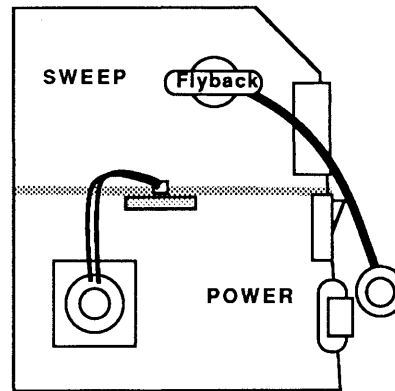

FIGURE 4

The speaker and the battery compartment are located on the power/sweep board. However, all the signals that operate these components are generated on the logic board; the power/sweep board does not use either of these items.

The power supply section is located on the bottom half of the board. This is where the AC voltage is converted to DC voltage for use by the entire system.

The sweep section is located on the upper half of the board. There are circuits for both the horizontal and the vertical signals that are fed to the CRT. The flyback transformer is part of the sweep section and delivers high voltage directly to the CRT through the anode connector.

CRT

The CRT (cathode-ray tube) provides the high-resolution video display. The power/sweep board connects to the anode to apply high voltage to the CRT.

The power/sweep board connects to the neck and to the yoke to supply various voltages and signals to the CRT to create the video display.

Disk Drives

The internal disk drive connects to the main logic board through an internally installed connector. The external drive connects to the port on the back of the logic board.

Reading and writing operations are controlled by the IWM on the logic board. The data passes through this IC on its way from the logic board to the disk in the drive, or from the disk drive to the logic board.

The Macintosh has 400K disk drives. The Macintosh Plus has 800K disk drives. The 400K disks work on the 800K drives. The 800K disks do **not** work on the 400K drives.

Mouse

The mouse connects to a nine-pin connector on the main logic board. The mouse is used to position the cursor on the screen.

The assemblies inside the mouse send a series of pulses to the SCC and the VIA. These ICs interpret and translate the information so that the logic board can utilize it.

Keyboard

The keyboard connects to the logic board through a four-wire coil with a telephone-type connector. The keyboard has its own microprocessor, which is used to implement a serial bus for communicating with the logic board.

The keyboard data is sent in serial form to the VIA, where it is converted into parallel data and translated so that the logic board can use it.

□ KEYBOARD AND KEYSWITCH IDENTIFICATION

The Macintosh keyboard without the numeric keypad uses Alps keyswitches (Figure 5). The locking keyswitch is used for the Caps Lock key, the other keyswitch for all other keys on the keyboard.

The Macintosh Plus keyboard with the numeric keypad uses two versions of keyswitches, Alps and Mitsumi. The keyswitches are not interchangeable between boards. They can be identified by referring to Figure 5 below.

The procedure to replace a keyswitch is in Section 3, Keyswitch Replacement, under the *You Oughta Know* tab.

Note: Macintosh foreign language keyboards use the same type of keyswitches as the U.S. Macintosh keyboards.



KEYSWITCH		KEYBOARD
 <p>705-0070 ALPS LONG STEM ("Extended")</p>	 <p>705-0077 ALPS ALPHA LOCK ("Alternate Action")</p>	<p>661-96154 661-0322</p>
 <p>705-0104 MITSUMI KEYSWITCH</p>	 <p>705-0044 MITSUMI ALPHA LOCK KEYSWITCH</p>	<p>661-0362</p>

FIGURE 5

Macintosh and Macintosh Plus

Section 2 – Take-Apart

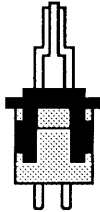
□ CONTENTS

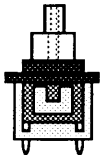
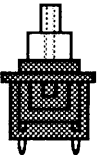
2.3	Electrostatic Discharge Prevention
2.3	Cover
2.6	Discharging the Cathode-Ray Tube (CRT)
2.6	Discharge Procedure
2.7	Anode Cap
2.9	Power/Sweep Board
2.12	Logic Board
2.15	Cathode-Ray Tube (CRT)
2.17	Internal Disk Drive
2.19	Chassis
2.20	Keyboard

Note: If a step is underlined, detailed instructions for that step can be found elsewhere in this section.



□ ELECTROSTATIC DISCHARGE PREVENTION

The Macintosh and the Macintosh Plus contain C-MOS components, and the Macintosh Plus RAM memory is installed on four small separate boards called SIMM modules. Both the C-MOS and the SIMM modules are very susceptible to ESD damage.

Preventive measures must be taken to avoid ESD damage. When you are unwrapping, installing, or replacing any modules, observe the appropriate ESD precautions.

For complete ESD prevention information, refer to *You Oughta Know*, Section 6.

□ COVER

Materials Required

Pull-apart tool
15-inch Torx screwdriver
Soft cloth or foam pad
Small, flat-blade screwdriver

WARNING: *Macintosh and Macintosh Plus computers contain high voltage and a high-vacuum picture tube. To prevent serious personal injury and property damage, be sure you read and understand the safety precautions in Section 8, CRT Safety, under the You Oughta Know tab before you remove the back cover. Failure to follow the safety rules could result in serious injury.*

Remove

1. Turn the power off and disconnect the AC power cord from the source and from the back of the computer.
2. Disconnect the mouse and all other external cables from the back of the computer. Disconnect the keyboard.

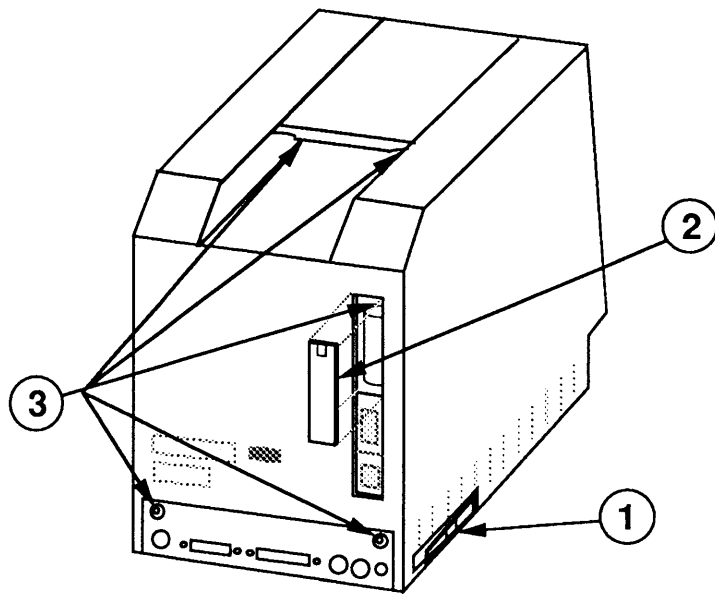

FIGURE 1

3. Remove the reset/interrupt switch (if installed) by prying it off with a small flat-blade screwdriver (Figure 1, #1).
4. Press down the tab at the top of the battery compartment cover (Figure 1, #2), and pull the tab toward you.
5. Carefully place the computer face-down on a soft cloth or foam pad (to prevent scratching the bezel).
6. Use a Torx screwdriver to remove the five screws (Figure 1, #3).
7. Use the pull-apart tool to gently pry the cover loose. Carefully lift up the cover (there is a fragile picture tube inside), and set it out of the way.

WARNING: *The edges of the metal chassis may be sharp. When moving the computer with the cover removed, be sure to handle the metal chassis carefully.*

Replace

1. Make sure that the insulating paper is in the proper position (Figure 2, #1) and that all cables are connected. Carefully slide the cover back onto the computer and check to see that it is properly seated.
2. Replace the five screws on the back of the computer.
3. Replace the battery compartment cover.
4. Replace the reset/interrupt switch if it was installed.

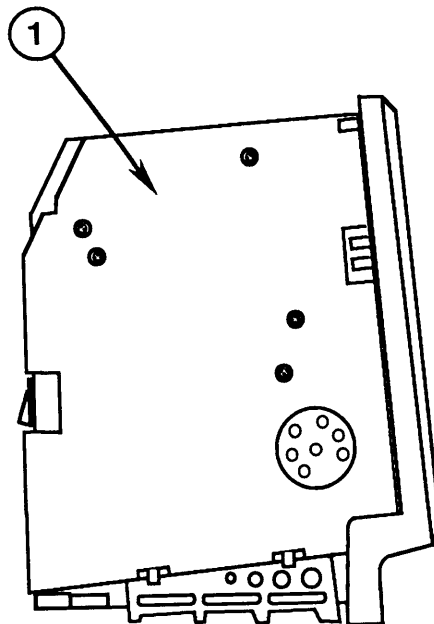

FIGURE 2

□ DISCHARGING THE CATHODE-RAY TUBE

Materials Required

Safety goggles
Foam pad (ungrounded)
Needlenose pliers
Alligator lead
New CRT discharge tool (part number **076-0381**)

WARNING: Before starting, read the safety precautions and the CRT discharge procedure in Section 8, CRT Safety, under the You Oughta Know tab. Alternative instructions for discharging the CRT using the older version of the discharge tool (and/or a screwdriver) are also given in that section.

Discharge Procedure

1. Remove your grounding wriststrap and jewelry and put on safety goggles before beginning!

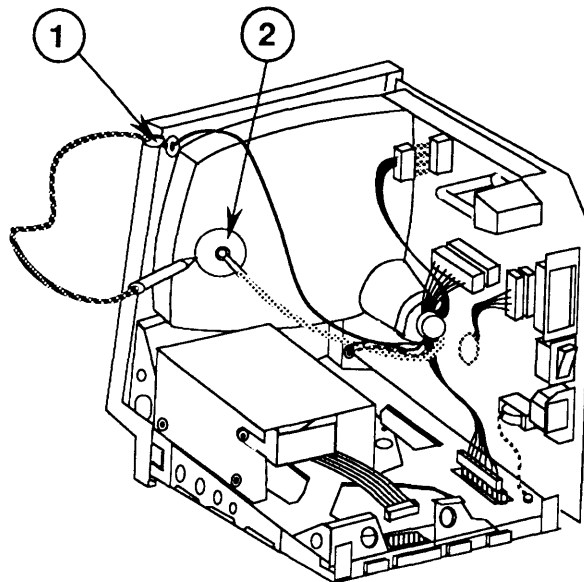

FIGURE 3

2. Attach the alligator clip on the CRT discharge tool to the metal part of the **ground lug** (Figure 3, #1).

WARNING: If you discharge the Macintosh CRT to the metal chassis, the logic board may be destroyed because its circuitry is grounded to the chassis. You must discharge to the ground lug!

3. Put one hand in your pocket or behind your back and grasp the insulated handle of the CRT discharge tool. Insert the probe of the tool under the anode cap (Figure 3, #2) until it touches the anode ring.
4. Remove the probe of the CRT discharge tool from under the anode cap. Remove the alligator clip from the ground lug.

Note: The anode can build up voltage over time. To drain off any residual charges, establish an ongoing ground by fastening one end of an alligator lead to the ground lug and the other end to the anode aperture.

Anode Cap

For some procedures, you may have to remove the anode cap. To do so, peel back the anode cap until you can see the anode ring (or connector) at the center. Using needlenose pliers, compress the two prongs on the connector to free it from the anode aperture.

To replace the anode cap, press together the two prongs of the anode connector so that you can insert it into the aperture. Tug on the anode wire to make sure it is firmly seated, then press down around the edges of the rubber anode cap to ensure a firm seal.

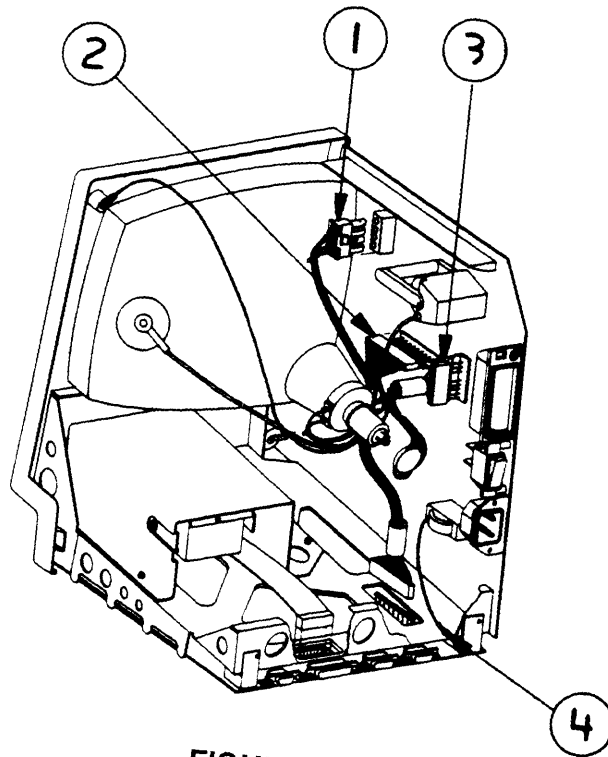

FIGURE 4

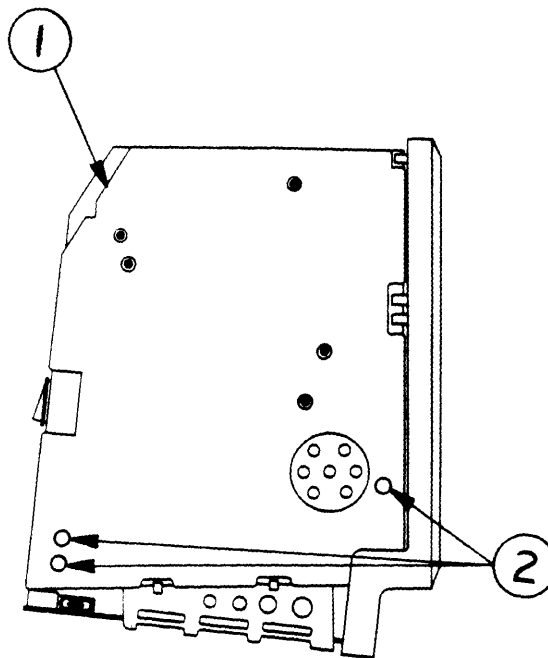

FIGURE 5

□ POWER/SWEEP BOARD

Materials Required

Pull-apart tool
15-inch Torx screwdriver
Safety goggles
Soft cloth or foam pad
New Apple CRT discharge tool (part number **076-0381**)

WARNING: *If you are using the older version of the discharge tool or a screwdriver with alligator leads, see the precautions in "Discharging the CRT" in Section 8, CRT Safety, under the You Oughta Know tab.*

If a new power/sweep board is installed, perform the voltage adjustment as shown in Section 5, Adjustments.

Remove

1. Remove the cover and discharge the CRT to the ground lug.

WARNING: *Make sure the anode has been discharged before continuing. Failure to discharge the anode could result in serious injury. Also, if you discharge the Macintosh CRT to the metal chassis, the logic board may be destroyed. You must discharge to the ground lug!*

2. Remove the anode cap.
3. Depress the tab on the yoke cable and unplug it (Figure 4, #1).
4. Remove the main logic cable from the power/sweep board (Figure 4, #2).
5. Remove the neck connector from the power/sweep board (Figure 4, #3).
6. Turn the computer upright and remove the screw, lockwasher, and ground wire at the bottom of the chassis (Figure 4, #4).
7. There are several versions of the insulating paper (Figure 5, #1). If there are no access holes for the three screws (Figure 5, #2), note how the paper is installed and then remove it.
8. Remove three screws and washers (Figure 5, #2), and lift up and pull out the power/sweep board.

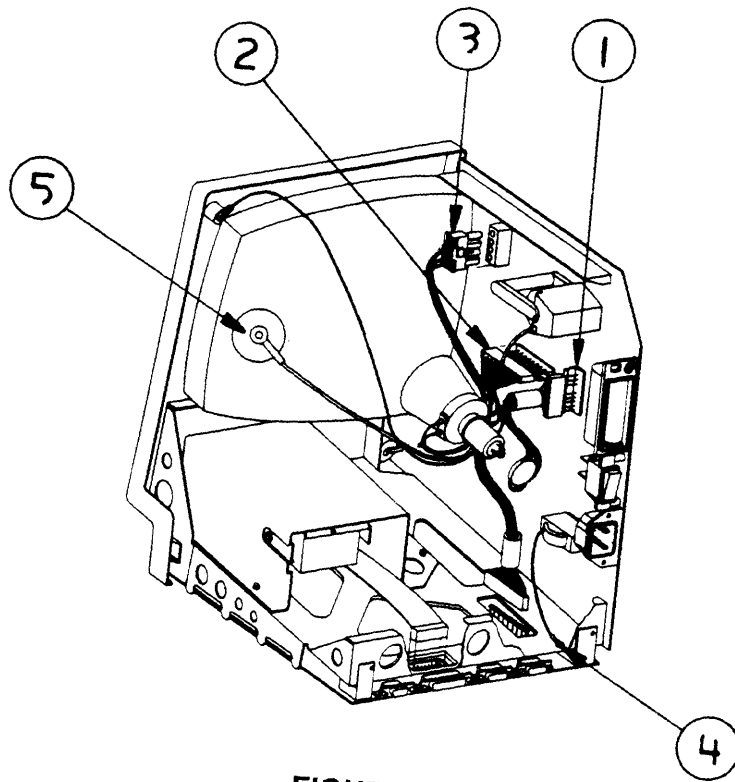

FIGURE 6

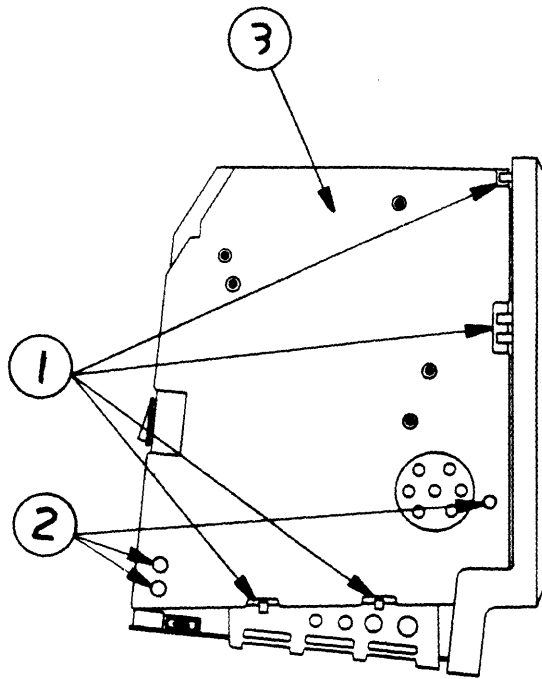

FIGURE 7

Replace

1. Turn the computer upright and position the power/sweep board at the right hand side of the chassis.
2. Connect the yoke cable (Figure 6, #1).
3. Connect the main logic cable (Figure 6, #2).
4. Slide the board into the slotted holders (Figure 7, #1) so that the three screw holes line up with the holes on the chassis (Figure 7, #2).
5. Connect the CRT socket cable to the power/sweep board (Figure 6, #3).
6. Replace the ground wire at the bottom of the chassis using a washer and Phillips head screw (Figure 6, #4).
7. Replace the three screws and washers (Figure 7, #2). If replacement screws are needed, refer to Section 6, Additional Procedures.
8. Replace the insulating paper if it has been removed (Figure 7, #3).
9. Connect the anode connector to the CRT (Figure 6, #5). Put one prong of the connector in at an angle and push it against the edge of the anode ring. Then insert the other prong.
10. Perform the voltage adjustment (refer to Section 5, Adjustments).
11. Replace the cover.

□ LOGIC BOARD

Materials Required

Pull-apart tool
15-inch Torx screwdriver
Safety goggles
Soft cloth or foam pad
New Apple CRT discharge tool (part number **076-0381**)

WARNING: If you are using the older version of the discharge tool or a screwdriver with alligator leads, see the precautions in "Discharging the CRT" in Section 8, CRT Safety, under the You Oughta Know tab.

Note: If a new logic board is installed, perform the voltage adjustment found in Section 5, Adjustments.

Remove

1. Remove the cover and discharge the CRT to the ground lug.

WARNING: Make sure the anode has been discharged before continuing. **Failure to discharge the anode could result in serious injury.** Also, if you discharge the Macintosh CRT to the metal chassis, the logic board may be destroyed. **You must discharge to the ground lug!**

2. Remove the main logic cable (Figure 8, #1) and the disk drive cable (Figure 8, #2) from the logic board.

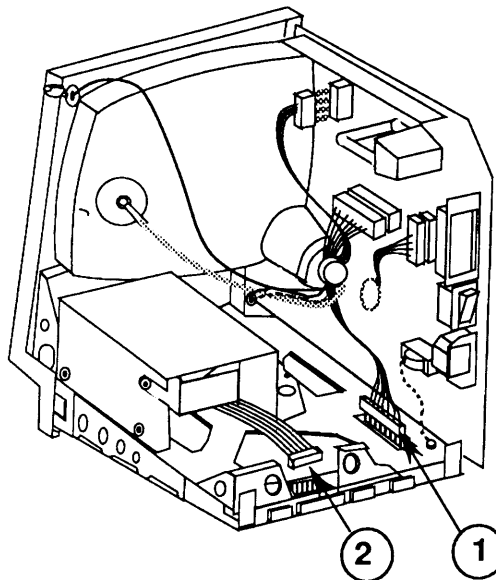

FIGURE 8

CAUTION: *DIP SIMMs, which may be installed on the logic board, are larger than other RAM SIMMs and can be easily damaged when removing the logic board. Use extra care when removing the logic board.*

3. Turn the computer face down. Gently slide the main logic board up and out of the chassis. **Pull back (away from the chassis) on the top of the logic board** while sliding it out so that any installed DIP SIMMs do not catch on the chassis.

Replace

If you are replacing the logic board of an enhanced 512K system, or a 512K system with an 800K disk drive, you must swap ROMs from the customer's faulty logic board to the replacement logic board. Swapping the ROMs will ensure that you do not downgrade the customer's system. For additional information, see "ROM Version Compatibility" in Section 6, Additional Procedures.

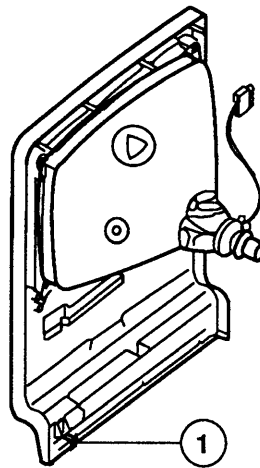

FIGURE 9

Note: If you are replacing a bad Macintosh Plus logic board with a rev. D (or higher) replacement board, you should install a ground clip (Figure 9, #1) to the inner plastic lip on the bottom front bezel (below the keyboard connector opening). You can identify a revision D replacement board by the part number; the part number has the format 820-xxxx-**D**. Do not use the ground clip with any logic board lower than rev. D.

CAUTION: *Contact between the ground clip and pins or solder points on the underside of the logic board could cause a short, resulting in erratic keyboard behavior. Make sure the clip does not touch any solder points.*

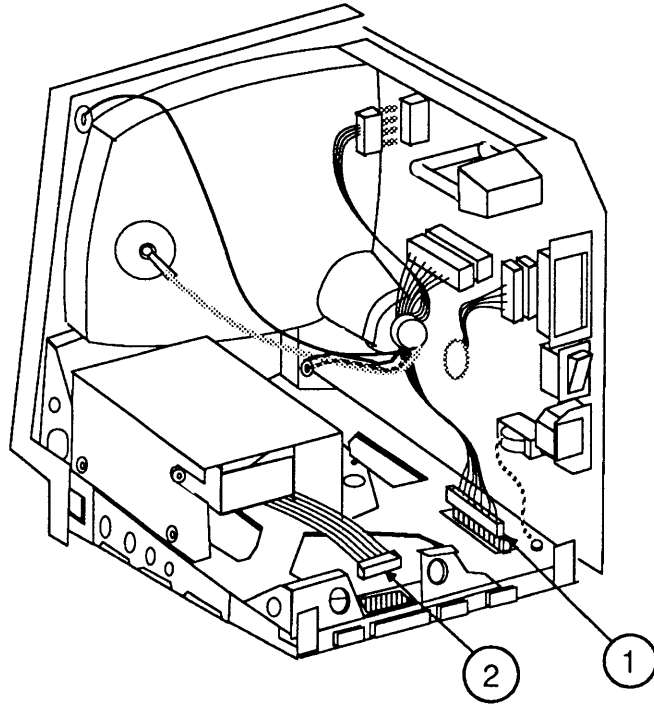

FIGURE 10

1. Gently slide the main logic board into the chassis until it is firmly seated.
2. Connect the main logic cable (Figure 10, #1) and the disk drive cable (Figure 10, #2).
3. Perform the voltage adjustment (refer to Section 5, Adjustments).
4. Replace the cover (be sure the insulating paper is installed).

□ CATHODE-RAY TUBE (CRT)

Materials Required

Pull-apart tool
15-inch Torx screwdriver
Safety goggles
Soft cloth or foam pad
New Apple CRT discharge tool (part number 076-0381)

WARNING: If you are using the older version of the discharge tool or a screwdriver with alligator leads, see the precautions in "Discharging the CRT" in Section 8, CRT Safety, under the You Oughta Know tab.

Remove

1. Remove the cover and discharge the CRT to the ground lug.

WARNING: Make sure the anode has been discharged before continuing. **Failure to discharge the anode could result in serious injury.** Also, if you discharge the Macintosh CRT to the metal chassis, the logic board may be destroyed. **You must discharge to the ground lug!**

2. Remove the power/sweep board.

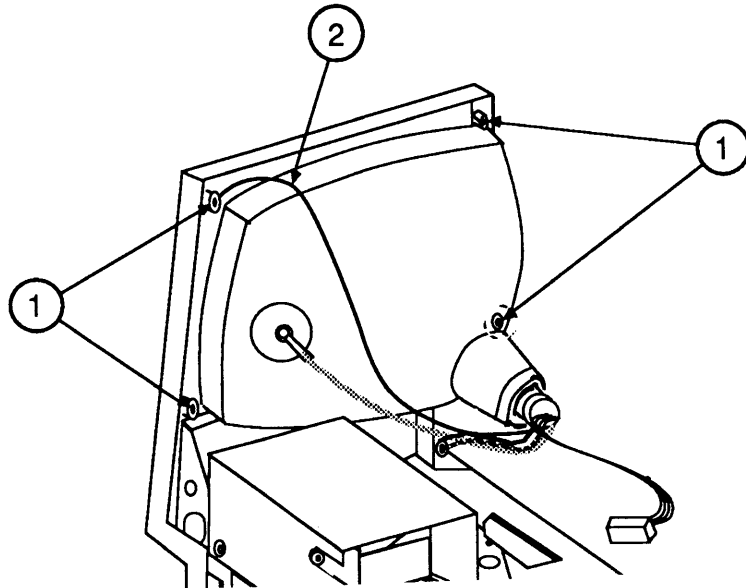

FIGURE 11

3. Place the computer face-down on a cloth or foam pad. Remove the four screws that fasten the CRT (Figure 11, #1) and the ground wire (Figure 11, #2).

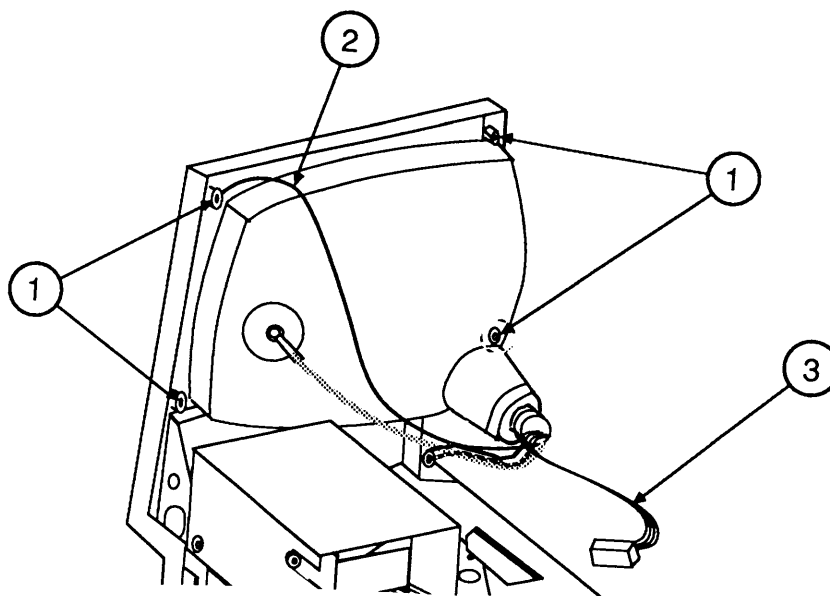

FIGURE 12

4. Gently remove the CRT socket cable (Figure 12, #3) by sliding it straight out from the neck.

WARNING: Handle the CRT by its sides only, not the neck. Do not touch the anode.

5. Remove the CRT.

WARNING: If you need to dispose of the CRT, refer to "Disposing of the Cathode-Ray Tube" in Section 8, CRT Safety, under the You Oughta Know tab.

Replace

1. Set the CRT in the case with the anode facing away from the power/sweep board (see Figure 12).
2. Connect the original CRT socket cable. A new CRT may have a small retainer on the neck pins. Remove it before replacing the CRT socket cable.
3. Replace the four CRT screws (Figure 12, #1). Be sure to reinstall the ground wire (Figure 12, #2).

□ INTERNAL DISK DRIVE

Materials Required

Pull-apart tool
15-inch Torx screwdriver
Safety goggles
Soft cloth or foam pad
New Apple CRT discharge tool (part number **076-0381**)

WARNING: *If you are using the older version of the discharge tool or a screwdriver with alligator leads, see the precautions in "Discharging the CRT" in Section 8, CRT Safety, under the You Oughta Know tab.*

Remove

1. Remove the cover and discharge the CRT to the ground lug.

WARNING: *Make sure the anode has been discharged before continuing. Failure to discharge the anode could result in serious injury. Also, if you discharge the Macintosh CRT to the metal chassis, the logic board may be destroyed. You must discharge to the ground lug!*

2. Remove the main logic board. Verify that the correct revision of ROM is installed. (Refer to Section 6, Additional Procedures.)
3. Turn the computer over and place it face down on a foam pad or soft cloth.
4. Locate the four Phillips screws that hold the disk drive and mounting bracket in position. Remove them from the chassis.
5. Slide the disk drive out of the chassis.

Note: All 400K drive mechanisms are shipped in their original internal drive shields. To exchange an 800K drive mechanism, you must first remove the drive mechanism from its original internal drive shield and install it in the Apple-approved packaging-and-shipping fixture. You should also install the dummy packing disk. See Figure 7 in the Illustrated Parts List for additional information.

IMPORTANT: Remove the plastic dust shield, if there is one, from the replacement drive before you install the drive in a Macintosh Plus.

Replace

Read "800K Diskette Ejection Problems" in Section 6, Additional Procedures, before replacing the disk drive.

Replacement 800K disk drive mechanisms should be installed in the customer's original internal drive shield. For 800K drives, you must first remove the shipping fixture, plastic dust shield (if any), and packing disk from the replacement drive mechanism before installing it in the original internal drive shield.

Examine the chassis and determine whether the mounting holes for the screws are *round* or *oval*. Then perform the appropriate procedure below.

Round Mounting Holes

1. Slide the new drive into position.
2. Align the mounting screw holes and tighten the four screws.

Verify the placement of the disk drive by inserting a disk into the disk drive and checking that the disk slides in and out of the drive without rubbing against the case.

3. Replace the main logic board and cover (be sure the insulating paper is installed).

Oval Mounting Holes

1. Slide the new drive into position.
2. Align the front of the drive with the plastic stops on the front of the bezel. Insert and tighten the four mounting screws.

Verify the placement of the disk drive by inserting a disk into the disk drive and checking that the disk slides in and out of the drive without rubbing against the case.

3. Replace the main logic board and cover (be sure the insulating paper is installed).

□ CHASSIS

Not all Macintosh chassis are designed the same way. However, the following procedure can be used to replace any Macintosh or Macintosh Plus chassis.

Materials Required

Pull-apart tool
15-inch Torx screwdriver
Safety goggles
Small flat-blade screwdriver
Soft cloth or foam pad
New Apple CRT discharge tool (part number **076-0381**)

WARNING: *If you are using the older version of the discharge tool or a screwdriver with alligator leads, see the precautions in "Discharging the CRT" in Section 8, CRT Safety, under the You Oughta Know tab.*

Remove

1. Remove the cover and discharge the CRT to the **ground lug**.

WARNING: *Make sure the anode has been discharged before continuing. **Failure to discharge the anode could result in serious injury.** Also, if you discharge the Macintosh CRT to the metal chassis, the logic board may be destroyed. **You must discharge to the ground lug!***

2. Remove the power/sweep board.
3. Remove the main logic board.
4. Remove the internal disk drive.
5. With the computer face-down on a foam pad or soft cloth, remove the five torx screws that secure the chassis to the front bezel, and lift out the chassis.

Replace

1. Position the replacement chassis on the front bezel, and install the five torx screws.
2. Replace the internal disk drive.
3. Replace the main logic board.
4. Replace the power/sweep board.

5. Perform the voltage adjustment (refer to Section 5, Adjustments).
6. Replace the cover (be sure the insulating paper is installed).

□ KEYBOARD

Exchanging the Keyboard

If you are exchanging the keyboard, **do not** remove the keyboard mechanism. Send the entire unit (**without** the cable) in for exchange. The procedure below is to be used for replacing keyswitches only.

Materials Required

Medium Phillips screwdriver

Remove

1. Disconnect the keyboard from the Macintosh or Macintosh Plus.
2. Remove the six screws from the back of the keyboard. Remove the top plastic cover.
3. Lift the mechanical assembly out of the bottom case.
4. Use the replacement procedures for Macintosh keyswitches in *You Oughta Know*. To identify the keyswitches, refer to Section 1, Basics.

Replace

1. Set the mechanical assembly back into the bottom case.
2. Position the top plastic cover.
3. Hold the cover in place, turn the keyboard over, and install the six screws.

Macintosh and Macintosh Plus

Section 3 – Diagnostics

□ CONTENTS

3.2	Introduction
3.2	MacTest
3.2	How to Use It
3.3	Things to Remember
3.5	Backup Procedure
3.10	Running MacTest
3.11	Materials Required
3.12	Pull-down Menus and Icons
3.12	512K
3.12	Select Test
3.14	Options
3.15	Apple
3.16	Miscellaneous Icons
3.16	Running the Diagnostic
3.19	Error Codes

Note: Always use the most recent revision of *MacTest*. Refer to the *Apple Service Programs Manual* for the number of the latest revision.

□ INTRODUCTION

MacTest

This section describes general procedures for using the *MacTest* diagnostic diskette to test the Macintosh and Macintosh Plus logic board and disk drives. *MacTest* is a pass/fail diagnostic test, which indicates the area being tested and the kind of test being performed when a failure occurs.

How to Use It

The *MacTest* diskette is used to identify module failures of the main logic board, keyboard, keypad, and disk drives on the 128K and 512K Macintosh as well as the 1024K Macintosh Plus.

Before running *MacTest*, read the section entitled "Things To Remember."

If you cannot boot the diskette, check the power cable and internal cable connections. If all the cables are secure, turn to Section 3, Troubleshooting, and replace the module(s) specified for the problem you are experiencing. Attempt to boot the diskette after each module swap to check whether the problem has been solved.

Replace modules when indicated by test results. Verify that the problem has been corrected by retesting with the diagnostic diskette. If correct operation is still not obtained, turn to the Troubleshooting section and follow its instructions.

If you receive an error code while attempting to run *MacTest*, check the list at the end of this section for what you can do to correct the problem.

□ THINGS TO REMEMBER

Backup Information

1. Make a backup diskette before you begin! When testing a defective Macintosh or Macintosh Plus, it is possible to erase and/or damage a section of the *MacTest* diskette.

There are two copy routines included on the *MacTest* diskette. Be sure to follow the instructions included in this section under "Backup Procedure."

Loopback Information

2. Identify the machine as a Macintosh or a Macintosh Plus. Connect the correct loopbacks for the machine you are testing (see "Materials Required" for more information).
3. Whenever a dialog box appears indicating that an item is not connected or installed (**keyboard** or **loopbacks**, for example), click in the **OK** box. **The test sequence will be aborted and an error code will be displayed.** Connect the item and/or deselect the test from the **Select Test** menu, reboot, and run the diagnostic again.
4. If the loopback cable and/or the SCSI loopback test card are not connected, be sure to deselect **Serial Loopback** and/or **SCSI Loopback [Mac+]** under the **Select Test** menu, and save the new configuration.

If you do not deselect the tests, a dialog box will appear asking if the loopback cables are installed. Click in the **OK** box. **The test sequence will automatically abort.**

5. If the loopback cable and/or the SCSI loopback test card are installed, be sure to select **Serial Loopback** and/or **SCSI Loopback [Mac+]** under the **Select Test** menu, and save the new configuration. If you do not select the tests, the ports will not be tested.
6. If you are using the SCSI loopback test card it must be correctly installed or the Macintosh Plus will be "recognized" as a 512K Macintosh.

Powering Off

7. To eject the *MacTest* diskette, pull down the **Options** menu and select **Shutdown**.

- Saving Configurations
8. Under **Options** is an item called **Save Configuration**. This option allows you to save a favorite configuration on the diskette. The name of the file **must** be **Options.OPTN** to run.
- DeskTop Appears
9. If the *MacTest* window does not appear but a screen with desktop and file icons does appear, you will need to:
- a) Open the *MacTest* diskette icon, and highlight the **MacTest** file icon.
 - b) Pull down the **Special** menu and select **Set Startup**.

The internal disk drive will whirl for a few seconds and stop.
 - c) Reboot the *MacTest* diskette.
- Stopping Continuous Test
10. To stop the continuous test, do the following (the mouse will respond slowly):
- a) Pull down the **Options** menu and select **Auto Run Not Selected**.
 - b) Pull down the **Options** menu and select **Save Configuration**.

The new configuration will be saved. The continuous test will stop after the next reboot cycle.
- Desk Accessories
11. All Desk Accessories must be closed before running *MacTest*.
- External Drives
12. *MacTest* cannot test an external drive that is connected through a Hard Disk 20.

□ BACKUP PROCEDURE

Two copy programs are included on the *MacTest* diskette for your convenience. Both routines require two disk drives.

400K Drive Copy

The destination diskette for the *400K Drive Copy* must be a double-sided diskette, but it must be inserted into a 400K external disk drive.

800K Drive Copy

The *800K Drive Copy* program must be run on the Macintosh Plus with 1024K of memory. The program will allow you to format and copy to either double- or single-sided diskettes.

Procedure

1. Write protect the *MacTest* diskette.
2. Insert the *MacTest* diskette, and power on the system.

The **Service MacTest** window will appear.

3. Pull down the **Options** menu and select **Quit to Finder**.

The drive will whir, and the desktop will appear with the *MacTest* diskette displayed in the upper right-hand corner.

4. Open the *MacTest* diskette icon.

The following file icons should be displayed.

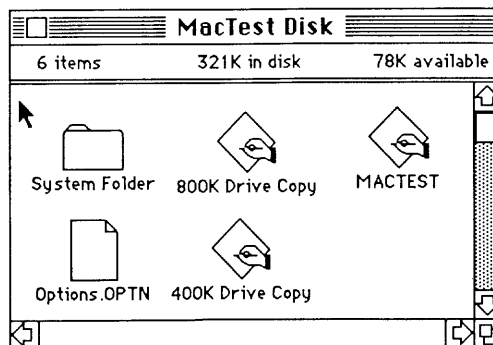

5. Open either the **400K Drive Copy** or the **800K Drive Copy** icon. Follow the appropriate instructions on the next few pages.

400K Drive Copy

1. The following window will appear.

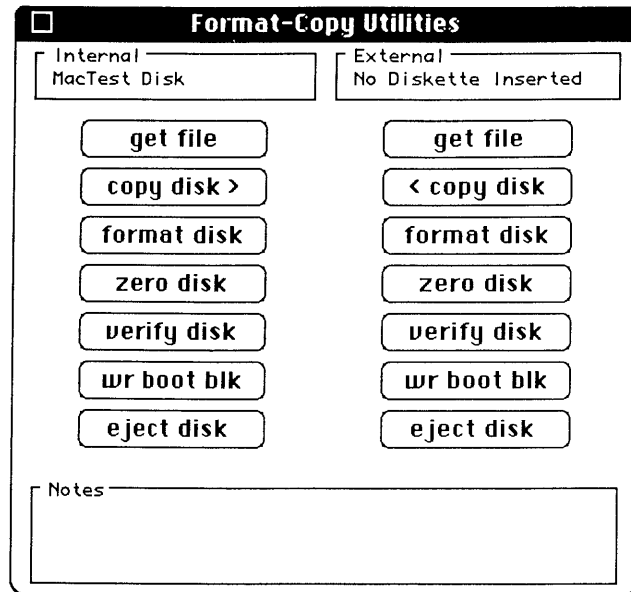

The message under **Internal Disk** should be "MacTest."

Dialog Box Appears

2. Insert a blank or a diskette you wish to copy over (double-sided) into the external drive. If a dialog box appears asking "Do you want to initialize it?":
 - a) Click in the box labeled **Initialize**.
 - b) A dialog box will appear asking you to name the diskette. Enter a name and then click in the box labeled **OK**.
 - c) The copy window will again be displayed. The name of the diskette in the external drive will appear in the block labeled **External Drive**.
 - d) Continue to step 3.

...Continued on next page

No Dialog Box Appears

If the dialog box does not appear:

- a) The name of the diskette will appear in the block labeled **External Drive**.
 - b) Under the box labeled **External** is a column of boxes with various commands. Click in the box labeled **Format**. The external drive will whirl and the message "Disk Format In Progress" will appear in the box labeled **Notes**. On completion the message "Disk Format Was Successful" will appear in the box labeled **Notes**.
 - c) Continue to step 3.
3. Under the box labeled **Internal** is a column of boxes with various commands. Click on the box labeled **<Copy Disk>**.

The message "Disk Copy In Progress" will appear in the box labeled **Notes**. The drives will whirl for a few minutes. The external drive will eject the diskette on completion of the copy. The message "Disk Successfully Copied" will appear under the box labeled **Notes**.

4. You now have two choices:

If you wish to make additional copies:

- a) Insert a blank or a diskette you wish to copy over into the external drive.
- b) Repeat steps 2 and 3.
- c) Repeat steps 4a and b until you have the number of copies you desire.

If you wish to quit making copies, pull down the **Utility** menu and select **Quit**. The desktop will appear.

You now have one or more copies of the *MacTest* diskette. Place the original in a safe place.

800K Drive Copy

1. The following window will appear.

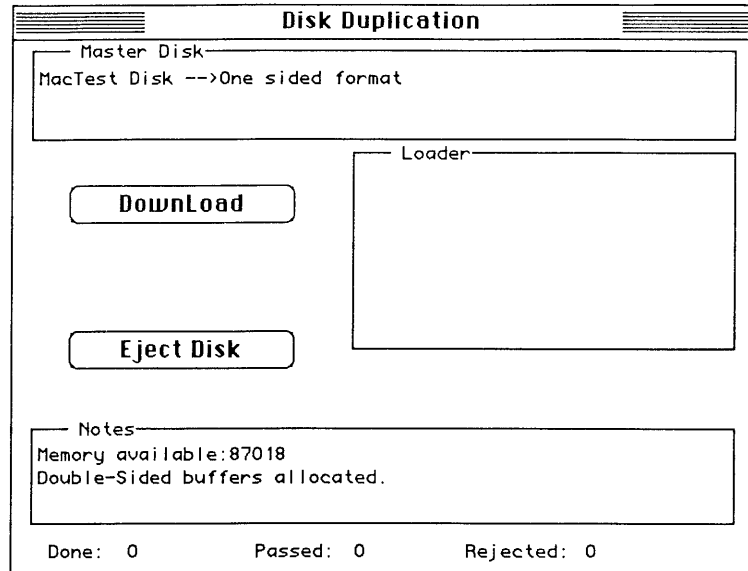

Wait till the **Watch** icon disappears.

2. Click in the box labeled **DownLoad**.

The message "Disk Download in progress..." will appear in the box labeled **Notes**. The drive will whir for approximately one minute, and then it will eject the *MacTest* diskette. The message "Disk Successfully Downloaded" will appear in the box labeled **Notes**.

3. Insert a blank or a diskette you wish to copy over (double-sided) into the external disk drive.
4. Click in the box labeled **Start**.

The message "Format/Copy in progress" will appear in the box labeled **Notes**. The drive will whir, and the message will change to "Verify in progress." The message will change to "Disk Copy is successful" and the copy will be ejected from the external disk drive.

5. You now have two choices.

a) If you wish to make additional copies:

1) Insert a blank or a diskette you wish to copy over into the external drive.

The program will make another copy without any commands being entered.

2) Repeat this until you have the number of copies you desire.

b) If you wish to quit making copies.

1) Click in the box labeled **Stop**.

2) Pull down the **Options** menu and select **Quit**.

3) Insert the *MacTest* diskette, as instructed in the dialog box.

The desktop will return.

You now have a copy of the *MacTest* diskette. Place the original in a safe place.

□ RUNNING *MACTEST*

Materials Required

Identify which Macintosh you have by examining the connectors on the rear of the machine (see Section 1, Basics). Locate the following equipment for the Macintosh **or** for the Macintosh Plus.

Note: The loopback equipment does not need to be installed to run the diagnostic. However, to test the machine completely the loopbacks should be used. Refer to "Things to Remember" at the beginning of this section.

Macintosh

MacTest diagnostic diskette
DB 9 Serial Port Plug (Set of 2)
Blank 400K formatted diskette for External Drive Test

The DB 9 loopback connectors should be installed on the two serial ports on the rear of the machine.

Macintosh Plus

MacTest diagnostic diskette
DIN-8 to DIN-8 Serial Port Cable (loopback connector)
SCSI Loopback Test Card
Blank formatted 400K diskette for External Drive Test

The loopback cable with DIN-8 connectors should be installed between the two serial ports on the rear of the machine.

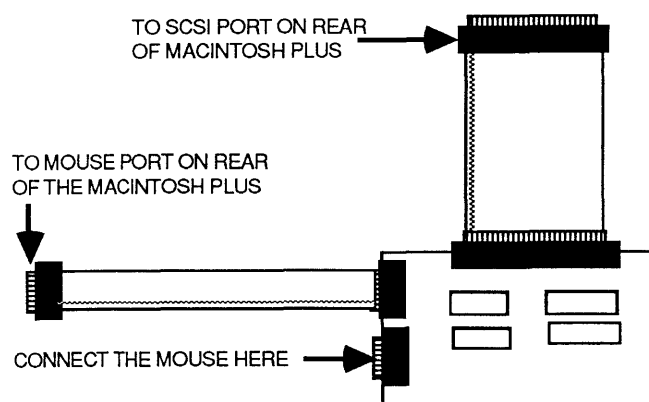

FIGURE 1

The SCSI Loopback Test Card should be connected to the Macintosh Plus (Figure 1). The cable connected to the SCSI port will need to be folded over in order to reach the port on the Macintosh Plus.

CAUTION: *Always power off the system when you connect or disconnect the SCSI loopback card.*

The new-style mouse with the small connector **must** be used. Gently jiggle the mouse connector onto the board at the location indicated below.

**Pull-Down
Menus and
Icons**

The following window should appear (on a 512K Macintosh).

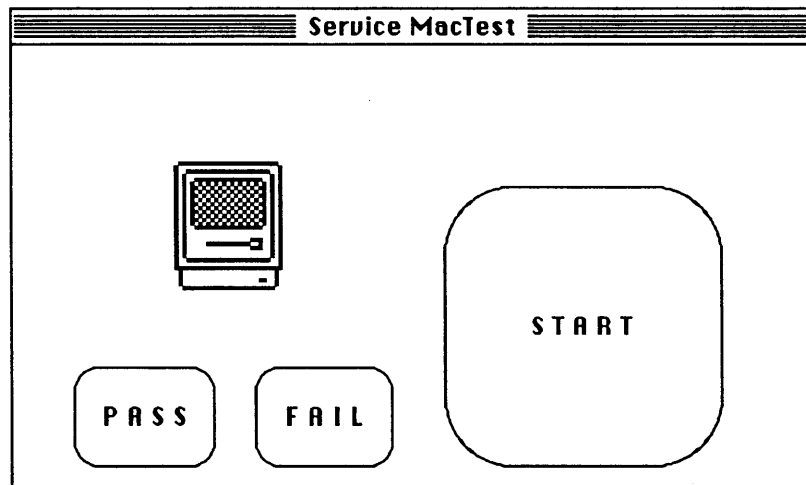

The following pages will explain how to use and what to expect from each of the features listed under the four pull-down menus.

512K



This pull-down menu indicates the amount of memory in the Macintosh or Macintosh Plus you are working on. For a 128K machine, **128K** would be displayed. For the Macintosh Plus, **1024K Mac+** would be displayed.

Select Test

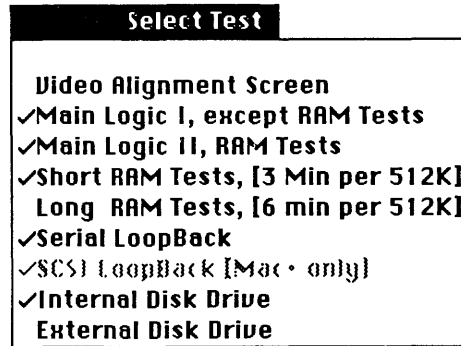

The **Select Test** menu lists the various tests available to you.

To select a test, pull down the menu and highlight the test you want, then release the mouse button. Pull down the menu again and notice the check mark that has appeared.

To deselect a test, pull down the menu and highlight the test you want, then release the mouse button. If you pull down the menu again, you will notice that the check mark is gone. The tests are described below.

Video Alignment Screen

The **Video Alignment Screen** is a white screen, with twelve grayscale squares for focus. The screen may be used to properly align and focus the video display.

Main Logic I, except RAM Tests

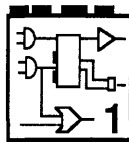

When selected, the **Main Logic I** verifies the working condition of various hardware items on the board.

The loopbacks do not have to be installed to run this test. However, if they are not installed, the **Serial Loopback** and **SCSI Loopback [Mac+]** tests should be deselected.

If the loopback tests are selected but the loopbacks are not installed, a dialog box will appear asking if the loopback connectors are installed: click in the **OK** box. **The test sequences will automatically abort when you click in the OK box.** Then you can either deselect the tests for the ports, save the configuration, and rerun *MacTest*, or install the loopbacks and rerun *MacTest*.

If the loopback cables are installed and you want the ports tested, you will need to select one or both of the loopback tests and save the configuration.

The icon shown above is displayed in the **Service MacTest** window when this test is being performed.

*Main Logic II,
RAM Tests*

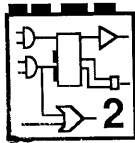

When selected, the **Main Logic II, RAM Tests** option verifies the RAM installed on the logic board. In order to test the RAM completely, you also need to select either the **Short RAM Tests [3 MIN per 512K]** or the **Long RAM Tests [6 Min per 512K]**. These selections will determine how long the RAM will be tested. When the RAM test is running, the menu bar at the top of the screen will flash slowly.

The icon above is displayed in the **Service MacTest** window when this test is being performed.

Internal Disk Drive

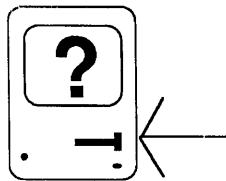

When selected, the **Internal Disk Drive** test verifies the functionality of the internal disk drive. The icon above is displayed in the **Service MacTest** window when this test is being performed.

External Disk Drive

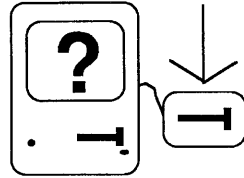

When selected, the **External Disk Drive** test verifies the functionality of the external drive. Insert a blank formatted diskette into the external drive before testing. The icon above is displayed in the **Service MacTest** window when this test is being performed.

Options

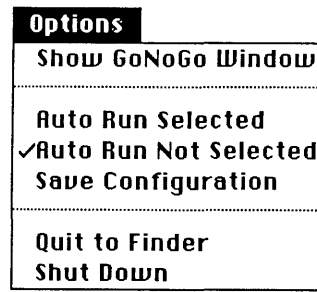

This **Options** menu lists the various features available when using the *MacTest* diskette. Check marks indicate options that are currently selected.

Auto Run Selected

Auto Run allows you to run the Logic I, Logic II (which must be selected) and Internal Disk Drive tests in a continuous loop. Appropriate loopback connectors must be installed to use the Automatic Run feature effectively. The External Disk Drive test may be selected, but it will run only once. Under Auto-Run *MacTest* will run automatically until a failure occurs. To stop the automatic test sequence, refer to Things to Remember.

Auto Run Not Selected

If **Auto Run Not Selected** is displayed, *MacTest* will run each selected test once and will then reboot and display the results with an icon.

Save Configuration

IMPORTANT: *The diskette must be unlocked before you try to save a configuration. The program does not warn you when the disk is locked.*

Save Configuration allows you to customize your *MacTest* diskette. Select the tests you want to run and select this feature. A window will appear with a file named **Options.OPTN** displayed. Click in the **Save** box.

The file you save must be named "Options.OPTN" to run.

Quit to Finder

Quit to Finder returns you to the desktop with the disk and file icons displayed.

Shut Down

Shutdown ejects the diskette and reboots the system.

Apple

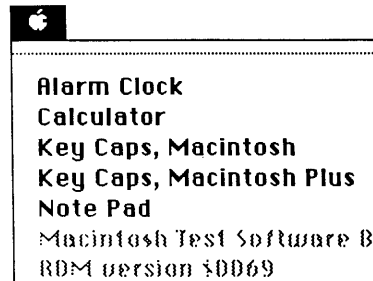

The Apple (🍏) menu allows you to test the keyboard, keypad, and speaker for the machine you are testing. Perform the logic board test before performing any of these tests.

IMPORTANT: *All desk accessories must be closed before running MacTest.*

Calculator

When selected, **Calculator** displays a window with a calculator. Press each key on the keypad and verify that it is highlighted in the window. If a key is not highlighted, the keyswitch is bad and the numeric keypad (Macintosh) or the keyboard (Macintosh Plus) should be replaced.

Key Caps

There are two **Key Caps** tests, one for the Macintosh and one for the Macintosh Plus. Choose the appropriate test. When selected, this feature displays a window with a keyboard. Press each key on the keyboard and verify that the display block for that key is highlighted. If the key is not highlighted, the keyswitch is bad and the keyswitch should be replaced. If numerous keys are not highlighted, exchange the keyboard.

Miscellaneous Icons

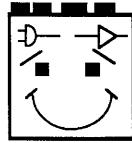

Pass

If all tests pass, the Macintosh/Macintosh Plus will reboot after a few minutes, momentarily highlight the **PASS** icon box, and display a "happy face" icon, similar to the one above.

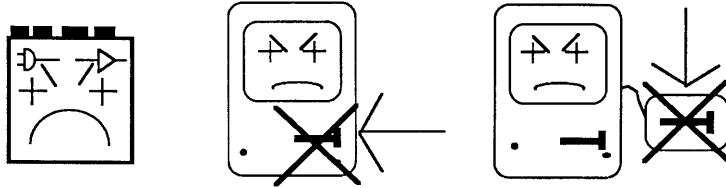

Fail

If a test fails, a bad module will be indicated by a "sad face" icon of the specific module. If any test fails, the tests will stop running and the **FAIL** icon box will be highlighted. The icons are (above from left to right): the logic board, the internal disk drive, and the external disk drive.

Running the Diagnostic

The following are abbreviated procedures for running a standard test, a customized test, or a continuous test. The amount of time you need to run the diagnostic will range from two minutes to twenty minutes, depending on your machine and the tests you select.

If you need additional information, refer to "Things to Remember" and "Pull-Down Menus and Icons."

Standard

The *MacTest* diskette is shipped configured to run the Logic I test, the Logic II test, and the the Internal Drive tests.

1. Install the appropriate connectors for the machine you are testing.

2. Turn on the machine.

An icon of a disk with a flashing question mark should appear.

3. Insert the *MacTest* disk into the internal drive.

The **Service MacTest** window should appear. The amount of memory will be displayed in the menu bar.

4. Click the **Start** icon box.

MacTest will run the tests selected under the menu **Select Test**.

If the tests pass, the machine will reboot and the "happy Macintosh" icon will appear.

If a test fails, a "sad Macintosh" icon of the bad module will appear.

5. Pull down the **Apple** menu and perform the **Key Caps** and **Calculator** tests, if applicable.

Customized

This test allows you to select the modules you want to test, be it one module or any combination of modules.

1. If the logic board is to be tested, install the appropriate loopback connectors for the machine you are testing.

2. Turn on the machine.

An icon of a disk with a flashing question mark should appear.

3. Insert the *MacTest* disk into the internal drive.

The **Service MacTest** window should appear. The amount of memory will be displayed in the menu bar.

4. Select the test(s) you want to run from the **Select Test** pull-down menu.

5. On completion, pull down the **Options** menu and select **Save Configuration**.

A dialog box will appear with the message "Save Test Data as: Options.OPTN."

Click in the **Save** box.

A dialog box will appear asking, "Replace existing Options.OPTN?"

Click in the **Yes** box.

The disk will whirl for a few seconds and the **Service MacTest** window will be displayed.

6. Click in the **Start** icon box.

MacTest will run the tests selected under the menu **Select Test**.

If the tests pass, the machine will reboot and the "happy face" icon will appear.

If a test fails, a "sad face" icon of the bad module will appear.

Continuous

This test allows you to run the Logic I test, the Logic II test, and the Internal Disk Drive test continuously or overnight to check for intermittent problems.

1. The appropriate loopbacks must be installed to use the continuous test feature effectively.
2. Turn on the machine.

An icon of a diskette with a flashing question mark should appear.

3. Insert the *MacTest* diskette into the internal drive.

The **Service MacTest** window should appear. The amount of memory will be displayed in the menu bar.

4. Verify that the tests listed above are selected in the **Select Test** pull-down menu.

If they are not selected, select them now.

5. On completion, pull down the **Options** menu and select **Auto Run Selected**.

6. Then pull down the **Options** menu and select **Save Configuration**.

A dialog box will appear with the message "Save Test Data as: Options.OPTN".

Click in the **Save** box.

A dialog box will appear asking "Replace existing Options.OPTN?"

Click in the **Yes** box.

The disk will whirl for a few seconds and the **Service MacTest** window will be displayed.

7. Click in the **Start** icon box.

MacTest will run the tests selected under the menu **Select Test**.

If the tests pass, the machine will reboot and the "happy face" icon will appear. The cycle will be repeated continuously until stopped.

If a test fails, a "sad face" icon of the bad module will appear and the testing will stop.

8. To stop the continuous test do the following:

- a) Pull down the **Options** menu and select **Auto Test Not Selected**.

- b) Pull down the **Options** menu and select **Save Configuration**.

The new configuration will be saved and the continuous test will stop after the next reboot cycle.

Error Codes

Error codes may appear when you run the *MacTest* diskette. The following chart lists the various error codes that may be displayed (the X's in the error code can be ignored) and the things you should check to correct the problems.

Before using the chart, verify that you are using a **known-good MacTest** diskette.

If an error code is displayed, find it in the list below and check the items listed to the right. After each step, run *MacTest* to see if the error code is still displayed.

Error Code

Things to Check

100XX.XXXX

1. Keyboard connected correctly?
2. Exchange keyboard cable.
3. Exchange keyboard.
4. Exchange logic board.

200XX.XXXX

1. Appropriate loopback connectors installed?
2. Dialog box appeared asking if cables were connected?
3. Loopback connectors work OK on another machine?
4. Exchange logic board.

300XX.XXXX

1. Check items listed for 200XX.
2. Exchange logic board.

400XX.XXXX

1. *MacTest* diskette unlocked?
2. Exchange internal disk drive.

500XX.XXXX

1. Blank formatted 400K diskette installed in external disk drive before running test?
2. Formatted diskette unlocked?
3. Exchange external disk drive.

600XX.XXXX

- Exchange Logic Board.

Macintosh Plus Error ONLY

800XX.XXXX

1. SCSI Loopback Test Card connected?
2. Dialog box appeared asking if cables were connected?
3. SCSI Loopback Test Card works OK on another machine?
4. Exchange logic board.

Macintosh and Macintosh Plus

Section 4 – Troubleshooting

□ CONTENTS

4.2	Introduction
4.2	General Information
4.2	Before You Start
4.2	How to Use the Symptom Chart
4.2	Exchanging the Logic Board
4.2	Exchanging the Power/Sweep Board
4.3	Things to Remember
4.4	Symptom Chart
4.4	Video Problems
4.5	Drive Problems
4.7	Peripheral Problems
4.8	Miscellaneous Problems

□ INTRODUCTION

General Information

Use this troubleshooting section if the diagnostics are unable to detect a module failure or if the diagnostic disk cannot be booted. After you repair the system, run the diagnostic test to verify system operation.

Before You Start

Read the section entitled "Things to Remember" before you begin troubleshooting. There are a number of things you should know about the Macintosh or Macintosh Plus to troubleshoot them effectively.

How to Use the Symptom Chart

Use the left-hand column to find the symptom that most nearly describes the problem of the defective unit. For that symptom, perform the corrective action(s) in the order listed. If a corrective action does not fix the problem, proceed to the next step. If a board is replaced but does not fix the problem, the original board should be reinstalled before you perform the next step.

Exchanging the Logic Board

Boot ROMs for the Macintosh Plus and Macintosh 512K enhanced systems exist in several versions that cannot be mixed on the same logic board. For more information, see "ROM Version Compatibility" in Section 6, Additional Procedures.

When exchanging 512K logic boards, make sure that you do not downgrade the customer's system. If the customer has a 512K enhanced system (new ROMs installed on the logic board), you will need to swap ROMs so that the customer keeps the same ROMs. Refer to "ROM Version Compatibility" in Section 6, Additional Procedures, for more information.

Exchanging the Power/Sweep Board

When sending Apple a defective power/sweep board from a Macintosh or Macintosh Plus, be sure to include the power/sweep-to-logic-board cable. Make sure the contrast control knob and battery have been removed from the defective board and reinstalled onto the exchange board.

□ THINGS TO REMEMBER

1. Follow the basic ESD precautions when troubleshooting. (Refer to Section 2, Take-Apart, for more information.)
2. Be sure you read all the safety precautions before removing or installing any modules (refer to Section 1, Basics).
3. Be sure you discharge the CRT before removing or installing any modules. (Refer to Section 2, Take-Apart, for specific information.)
4. Be sure the software you use is known-good. Bad software can produce symptoms that appear to be hardware problems.
5. When exchanging the logic board or the power/sweep board, you must adjust the voltage. (Refer to Section 5, Adjustments, for complete instructions.)

□ SYMPTOM CHART

Video Problems

Solutions

- *No video, but audio tone is present and drive operates*
 1. Turn contrast control fully clockwise.
 2. Check video cable connections.
 3. Replace neck cable.
 4. Replace power/sweep board.
 5. Replace logic board.

- *Screen is bright and audio is present, but no video information is present*
 1. Replace power/sweep board.
 2. Replace logic board.

Drive Problems

Solutions

IMPORTANT: When exchanging an 800K drive, either internal or external, refer to Section 6, Additional Procedures, for exchange module compatibility information.

- *Disk ejects; display shows disk icon with blinking "X"*
 1. Replace bad disk.
 2. Replace drive cable.
 3. Replace disk drive.
 4. Replace logic board.

- *Unable to insert disk all the way*
 1. Insert a paper clip into the small hole beside the drive slot, or power off the system and hold the mouse button down while powering on to ensure the eject cycle has been completed. Then insert the disk with the metal slot forward and the write-protect tab on the bottom.
 2. Replace the disk drive.

- *Drive will not eject disk*
 - Refer to Section 6, Additional Procedures.

- *Will not read disks on internal drive*
 1. Replace bad disk.
 2. Replace drive cable.
 3. Replace Mylar RFI shield.
 4. Replace internal drive.
 5. Verify ROMs on the logic board (refer to Section 6, Additional Procedures).
 6. Replace logic board.

- *Will not read disks on external drive*
 1. Replace bad disk.
 2. Replace drive cable.
 3. Replace Mylar RFI shield.
 4. Replace external drive.
 5. Verify ROMs on the logic board (refer to Section 6, Additional Procedures).
 6. Replace logic board.

Drive Problems (continued)

Solutions

- *Audio tone sounds at power on, video is present, but drive does not operate*
 1. Replace disk drive cable.
 2. Replace disk drive.
 3. Replace main logic board.

- *Disk drive runs continuously*
 1. Replace bad disk.
 2. Replace drive cable.
 3. Replace disk drive.
 4. Replace logic board.

- *400K drive will not boot*
 1. If the logic board has Rev. A ROMs and the drive stepper motor is serial number F518 or higher, upgrade to Rev. B ROMs (refer to Section 6, Additional Procedures).
 2. Replace disk drive.

Peripheral Problems

Solutions

- *Cursor does not move*
 1. Connect mouse.
 2. Replace mouse.
 3. Replace logic board.

- *Cursor moves but clicking mouse produces no response*
 1. Replace mouse.
 2. Replace logic board.

- *No response to any key on keyboard*
 1. Replace keyboard cable.
 2. Replace keyboard.
 3. Replace logic board.

- *No response from a particular key*
 1. Replace keyswitch.
 2. Replace keyboard.
 3. Replace logic board.

- *Known-good ImageWriter or ImageWriter II will not print*
 1. Replace software with known-good.
 2. Make sure that the Chooser and the Control Panel are set correctly.
 3. Replace interface cable.
 4. Replace logic board.

- *Known-good LaserWriter will not print*
 1. Make sure that the Chooser and the Control Panel are set correctly.
 2. Replace software with known-good.
 3. Refer to *Apple Service Technical Procedures: Networks*.

Miscellaneous Problems

Solutions

- *When switched on, Macintosh Plus continuously beeps and tries to power up*
 1. Perform voltage adjustment (refer to Section 5, Adjustments).
 2. Disconnect internal disk drive. If this eliminates problem, replace drive.
 3. Replace logic board.
 4. Replace power/sweep board, logic board, and internal drive. **Replacing only power/sweep board may damage new power/sweep board.**

- *Clicking or chirping sound*
 1. Connect logic board cable.
 2. Perform voltage adjustment (refer to Section 5, Adjustments).
 3. Replace power/sweep board.
 4. Replace logic board.

- *Smoke/odor from Macintosh*
 - Replace power/sweep board.

- *No video, no audio tone, and no drive operation*
 1. Connect power cord.
 2. Switch power on.
 3. Replace power cord.
 4. Check fuse.
 5. Replace power/sweep board.
 6. Replace logic board.

- *MacTest displays 128K/512K when you test a 1-megabyte Macintosh Plus*
 - Replace Macintosh Plus logic board.

- *When developer's switch is installed, Macintosh Plus sometimes will reset intermittently*
 - Remove switch and file it down about 1/16 inch.

**Miscellaneous Problems
(continued)**

Solutions

- *Macintosh Plus hangs on startup* – If the logic board has the ROMs 342-0341-A or B (ROM HI) and 342-0342-A (ROM LO) and a peripheral device is connected to the SCSI port, the peripheral device must be turned on before powering on the Macintosh Plus. For additional information on ROM versions, refer to Section 6, Additional Procedures.
- *Macintosh 512K enhanced has two RFI Shrouds* – Some of these machines have two RFI shrouds installed. The two RFI shrouds can be replaced by one RFI shroud, which is orderable as a service part.
- *Stripped or lost Macintosh chassis screws* – Refer to Section 6, Additional Procedures.
- *Macintosh Plus boots but keyboard behaves erratically*
 1. Replace keyboard.
 2. Check that logic board grounding clip is not touching solder points beneath logic board.
 3. Replace logic board.

(

(

(

Macintosh and Macintosh Plus

Section 5 – Adjustments

□ CONTENTS

5.2	Power/Sweep Voltage Adjustment
5.2	Introduction
5.2	Materials Required
5.3	Voltage Adjustment
5.5	Yoke Adjustments
5.5	Introduction
5.5	Materials Required
5.5	Adjustment Procedures
5.8	Video Adjustments
5.8	Introduction
5.8	Materials Required
5.9	Adjustment Procedures

□ POWER/SWEEP VOLTAGE ADJUSTMENT

Introduction

The voltages must be verified whenever the logic board or the power/sweep board is exchanged. If the voltages are outside of the specified tolerances, the adjustments must be performed.

The adjustments are done with the power on, and all voltage measurements are taken on the disk drive port with no peripheral devices attached. The internal disk drive should not be running when the measurements are being taken.

WARNING: Read and follow all the safety precautions in Section 1, Basics, before performing any adjustments. Failure to follow the safety rules could result in serious injury.

Materials Required

Macintosh voltage test cable
Plastic alignment tool
Digital voltmeter (accurate to within 0.01 volts)

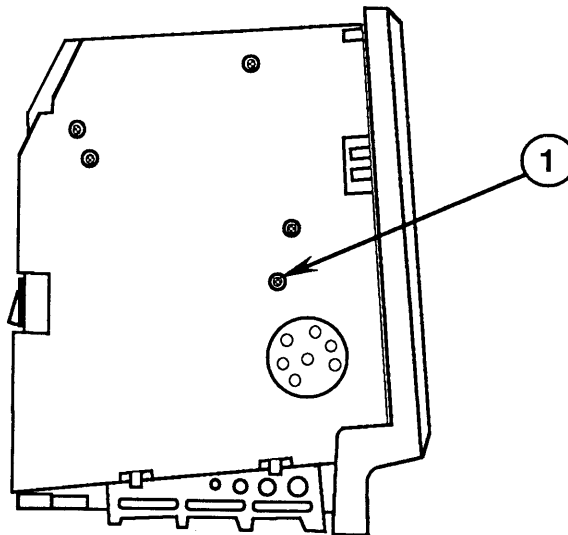

FIGURE 1

Voltage Adjustment

1. Switch off computer power and disconnect the AC power cord from the back of the computer.
2. Remove the cover.
3. Connect the voltage test cable to the external disk drive port at the back of the computer.

Note: The end of the voltage test cable that is not connected to the external drive port has four colored test leads. You will be using the orange and red leads to check computer voltages.

4. Set up the voltmeter as follows:
 - a) Set the voltmeter to the proper voltage range.
 - b) Connect the black voltmeter test lead between the ground terminal on the voltmeter and the computer chassis (ground).
 - c) Connect the orange test cable lead (12-volt lead) to the voltage input terminal on the voltmeter.

WARNING: *If the banana plugs on the test cable short to one another, the Macintosh will be damaged. Make sure that the banana plugs are insulated by their rubber hoods when not in use.*

5. Connect the AC power cord, switch on computer power, and check the voltage reading.

The voltage reading must be between 11.90 and 12.75 volts. If the voltage is not within these tolerances, use the alignment tool to adjust the voltage regulator (Figure 1, #1) on the power/sweep board to 12.75 volts. You must adjust this voltage to the high end of the reading because the next adjustment (5-volt) will affect this voltage setting.

6. Switch off computer power. Disconnect the orange test lead and replace its insulating hood.

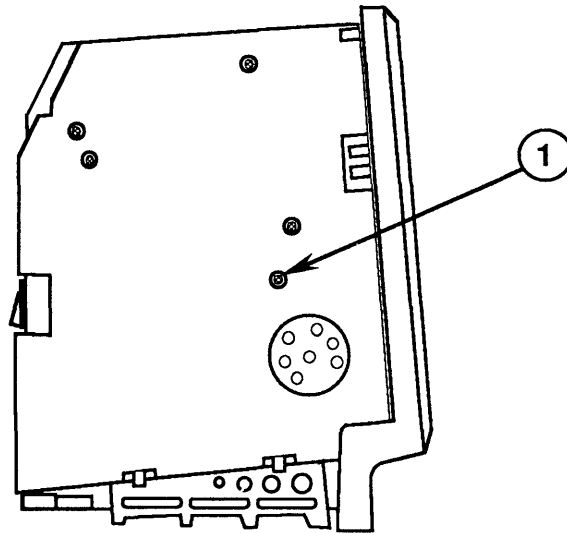

FIGURE 2

7. Connect the red test lead (5-volt lead) to the voltage input terminal on the voltmeter, switch on computer power, and check the voltage reading.

The voltage reading must be between 4.85 and 5.15 volts. If the voltage is not within these tolerances, use the alignment tool to adjust the voltage regulator (Figure 2, #1) on the power/sweep board to the specified limits.

8. Switch off computer power. Disconnect the red test lead and replace its insulating hood.
9. Repeat steps 4 through 8 to verify that both voltages are within the specified tolerances.

If the power/sweep board cannot be adjusted so that both voltages fall within the tolerances indicated above, the board should be exchanged.

10. Disconnect the AC power cord and all test leads from the computer.
11. Replace the cover.

□ YOKE ADJUSTMENTS

Introduction

If you replace the CRT, you will probably need to adjust the yoke. To determine if yoke adjustments are required, turn the power on and observe the CRT screen. If the picture is tilted, perform the tilt adjustment. If the picture is off center, perform the centering rings adjustment.

Yoke adjustments are made from the rear of the computer. You will need to position a mirror so that you can view the front of the computer. **Do not try to adjust by reaching around the computer;** you can't see what your hands are going to touch.

WARNING: Read and follow all the safety precautions in Section 1, Basics, before performing adjustments. Failure to follow the safety rules could result in serious injury.

Materials Required

Small flat-blade screwdriver
CRT discharge tool
Soft cloth or foam pad
Mirror

Adjustment Procedures

1. Remove the cover and discharge the CRT to the ground lug (refer to Section 2, Take-Apart).
2. Turn the computer with its back facing you and position the mirror so that the CRT screen is visible in the mirror.

Tilt

3. Loosen the yoke clamp screw (Figure 3, #1) two or three turns.
4. Connect the power cord to the Macintosh, and then connect the other end to an electrical outlet. Turn the power on.
5. Put one hand behind your back and with your other hand grasp only the plastic spokes of the yoke collar (Figure 3, #2). Rotate the yoke and observe the effects on the picture. Rotate the yoke until the top and bottom edges of the picture appear parallel with the top and bottom edges of the bezel.
6. Turn the power off and unplug the computer. Discharge the CRT to the ground lug. Hold the plastic collar in position and **carefully** tighten the yoke clamp screw just enough so that the collar will not slip. Do not overtighten.

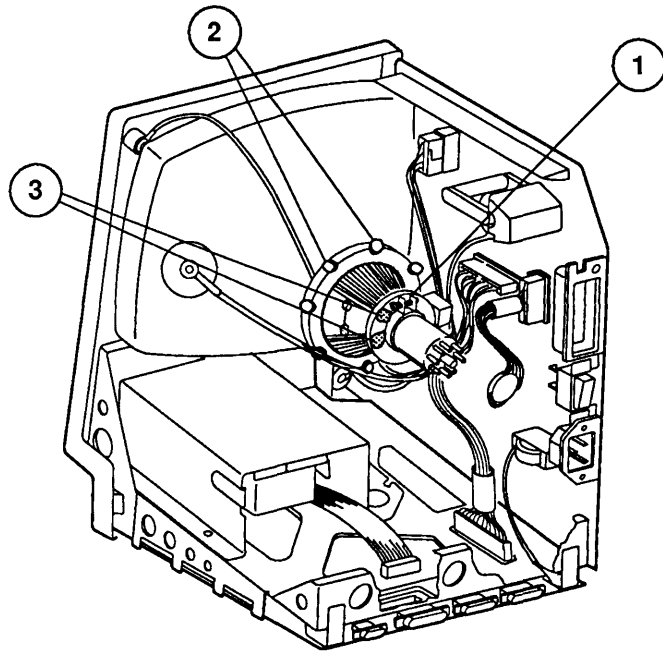

FIGURE 3

Yoke Centering Ring

7. Connect the power cord and turn the power on. Locate the two centering rings on the yoke assembly (Figure 3, #3). The adjustment of these rings determines whether the picture is centered or offset to one side.
8. Rotate each ring about half a turn and observe the effect on the screen.
9. Now center the picture by first holding the front ring steady and moving the rear ring, then holding the rear ring steady and moving the front ring.

□ VIDEO ADJUSTMENTS

Introduction

Video adjustments must be performed whenever the CRT or power supply/sweep, board is replaced.

Materials Required

Alignment tool
Mirror
Ruler

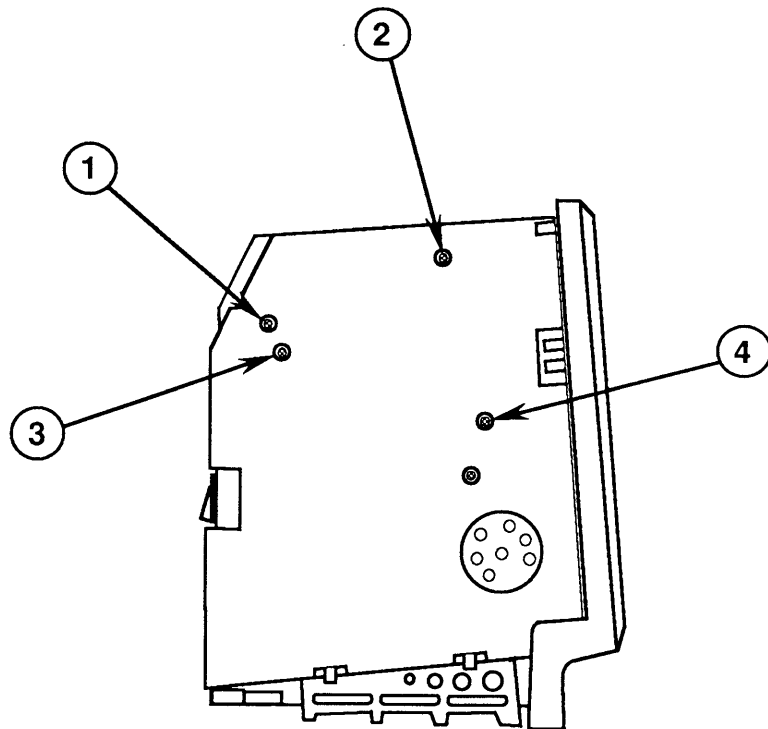

FIGURE 4

Adjustment Procedures

Brightness and Contrast

1. Put on safety goggles and remove all jewelry, including rings and necklaces.
2. Turn the contrast control fully clockwise. (The contrast control is on the front of the Macintosh, on the left side, under the Apple logo.)
3. Adjust the brightness control (Figure 4, #1) with the alignment tool: turn it fully counterclockwise so that white lines are visible on the screen. Then turn it back in the opposite direction until the white lines just disappear.
4. Turn the contrast control on the front panel 1/8 of a turn counterclockwise. This is the ideal adjustment.

Size Adjustments

5. Use the alignment tool to adjust the width (Figure 4, #2) until the picture is approximately 7 inches wide.
6. Use the alignment tool to adjust the height (Figure 4, #4) until the picture is approximately 4.7 inches high.

Focus Adjustment

7. Turn the focus adjustment (Figure 4, #3) all the way clockwise until it doesn't turn any more. Now turn it back in the opposite direction (counterclockwise) 1/8 of a turn. This setting gives the best overall sharpness at all points on the screen.



Macintosh and Macintosh Plus

Section 6 – Additional Procedures

□ CONTENTS

- 6.2 Macintosh Plus Kits
- 6.2 Things to Remember
- 6.3 Disk Drive and Logic Board Kits
- 6.4 Macintosh Plus Disk Drive Kit
- 6.7 Macintosh Plus Logic Board Kit
- 6.8 Special Problems
- 6.8 Alternate Chassis Screw Sizes
- 6.9 800K Drive Exchange Compatibility
- 6.9 800K Disk Ejection Problems
- 6.13 Logic Board ROM Upgrade and 400K Drives
- 6.14 Macintosh Plus RAM Upgrades
- 6.14 Logic Board Configurations
- 6.16 ROM Version Compatibility
- 6.16 ROM Upgrades for Enhanced Macintosh Systems
- 6.16 Replacing 512K Logic Boards

Note: If a step is underlined, detailed instructions for that step can be found in the Take-Apart section.

□ MACINTOSH PLUS KITS

WARNING: *Macintosh and Macintosh Plus computers contain high voltage and a high-vacuum picture tube. To prevent serious personal injury and property damage, be sure you read and understand the safety precautions in Section 8, CRT Safety, under the You Oughta Know tab before you remove the back cover. **Failure to follow the safety rules could result in serious injury.***

Things to Remember

When installing the Macintosh Plus Disk Drive Kit or the Macintosh Plus Logic Board Kit, pay special attention to the following:

1. Discharge the CRT as specified in Section 1, Take-Apart. Failure to do so can result in damage to the logic and power/sweep boards.
2. Follow the ESD prevention rules explained in Section 2, Take-Apart.
3. You may use 400K disks in the 800K drive, but be aware that the 800K drive may emit a squealing sound. This does not indicate a problem and will not cause damage to either the disk or the 800K drive.
4. The shipping instructions must be followed **exactly** as stated on the sheet included with the kit.
5. The 800K disk drive is shipped with a packing disk installed. This packing disk should be given to the customer. Whenever the machine is transported, the packing disk should be inserted to prevent damage to the drive.
6. Remind your customers that all their disks have to be updated with the most recent system files. The files are included in the kit and should be given to customers. Instructions for performing the system file upgrades are given in the manuals that accompany the kits.
7. When the drive kit is installed, the customer should be given the *Macintosh Plus Internal Drive Manual*.

8. When the drive kit and the logic board kit are installed, the customer should be given the Peripheral Adapter Cable, the *Macintosh Plus Owner's Guide*, the *Macintosh Plus Internal Drive Manual* and the *Macintosh Plus Information Sheet*.
9. The Macintosh Plus displays a gray screen for 5 to 10 seconds before booting from any disk. (The Macintosh Plus is running a self-check.)
10. The Macintosh Plus Disk Drive Kit is not recommended for the 128K Macintosh.
11. Insert the yellow packing disk into the new 800K disk drive to prevent damage during transport.

Disk Drive and Logic Board Kits

If you are installing the Macintosh Plus Disk Drive Kit and Logic Board Kit at the same time, follow these steps:

1. Turn to "Macintosh Plus Disk Drive Kit" and follow steps 1-4.
2. Turn to "Macintosh Plus Logic Board Kit" and follow step 5.
3. Turn back to "Macintosh Plus Disk Drive Kit" and follow steps 6-9.
4. Insert the yellow packing disk into the new 800K disk drive.
5. Return the **old** ROMs, the 400K drive, and the **old** 128K/512K logic board to Apple as instructed in the kits.

Macintosh Plus Disk Drive Kit

Read "Things to Remember" before beginning.

The Macintosh Plus Disk Drive Kit contains an 800K internal disk drive and two new boot ROMs. When installing it, you will replace the 400K internal disk drive and two socketed boot ROMs on the 512K Macintosh logic board. The new ROMs support both the 400K and 800K external disk drives.

Return Information

The shipping instructions must be followed **exactly** as stated on the sheet included with the Macintosh Plus Disk Drive Kit.

Procedures

1. Power off the Macintosh and remove the power cable from the machine.
2. Remove the rear housing and RFI shroud.
3. Discharge the CRT as specified in Section 2, Take-Apart.

WARNING: Make sure the anode has been discharged before continuing. Failure to discharge the anode could result in serious injury. Also, if you discharge the Macintosh CRT to the metal chassis, the logic board may be destroyed. You must discharge to the ground lug!

4. Remove the Macintosh logic board. Using an IC extractor, remove the old ROMs installed at locations D5 and D8. (Refer to Figure 1, Macintosh 128K/512K Logic Board.)
5. Install the two new ROMs in the appropriate locations: ROM HI (P/N 342-0341) at location D5, ROM LOW (P/N 342-0342) at location D8. (Refer to Figure 1, Macintosh 128K/512K Logic Board.) There is a notch at one end of each ROM. This notch should face the front of the machine.

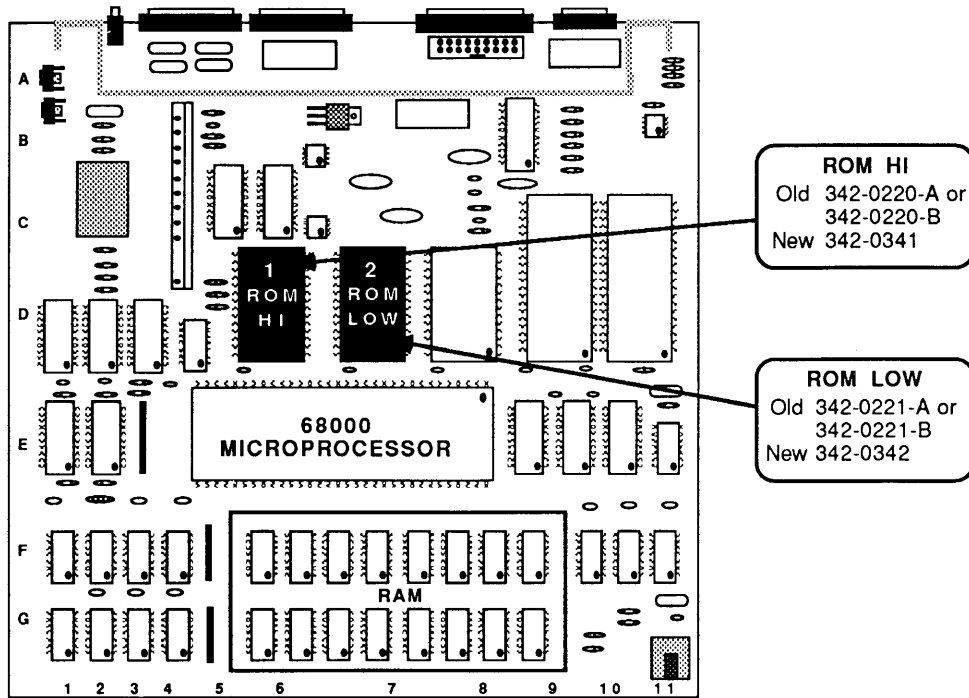

MACINTOSH 128K/512K LOGIC BOARD

FIGURE 1

6. Remove the internal disk drive (refer to Section 1, Take-Apart).
7. Reinstall the Macintosh logic board and install the new 800K internal disk drive.
8. Replace the RFI shroud and rear housing.
9. Run *MacTest* to verify that the machine is still working correctly.
10. Return the old ROMs and 400K disk drive to Apple (refer to instructions included in the kit).

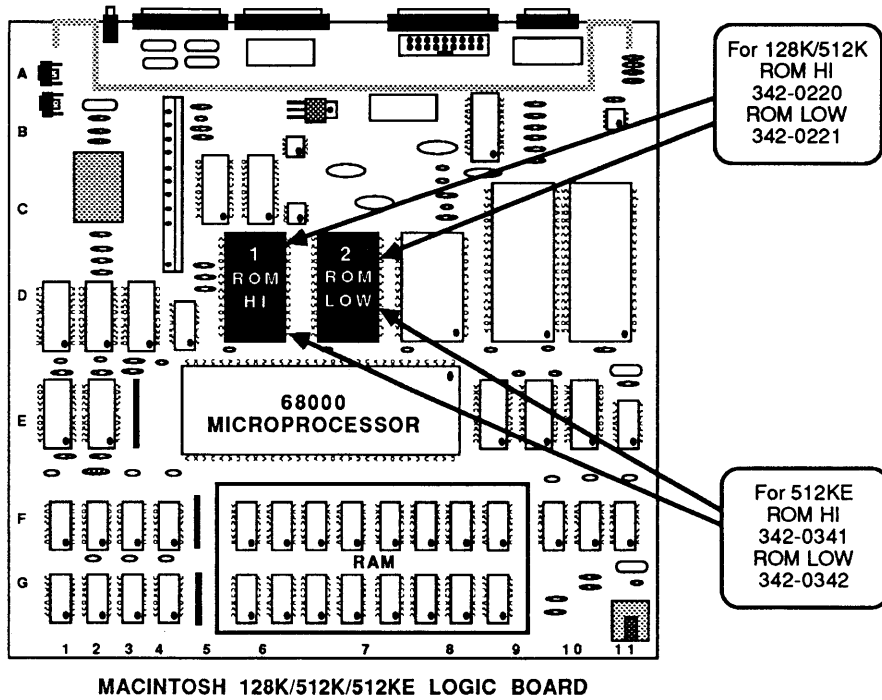

FIGURE 2

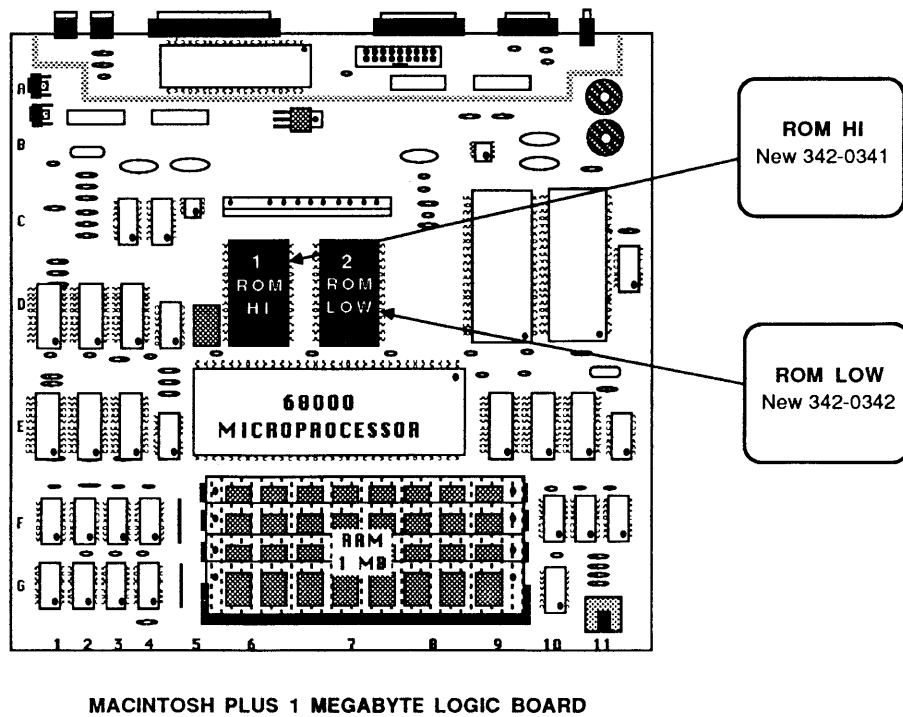

FIGURE 3

Macintosh Plus Logic Board Kit

Read "Things to Remember" before beginning.

The Macintosh Plus Logic Board Kit cannot be installed unless the Macintosh Plus Disk Drive Kit has been installed. You will need the new ROMs which were installed for the disk drive kit. The logic board kit includes a Macintosh Plus logic board with 1 megabyte of memory, an RFI shroud, and a new rear housing.

Return Information

The shipping instructions must be followed **exactly** as stated on the sheet included with the Macintosh Plus Logic Board Kit.

Procedures

1. Power off the Macintosh and remove the power cable from the machine.
2. Remove the old rear housing and RFI shroud.
3. Discharge the CRT as specified in Section 1, Take-Apart.

WARNING: Make sure the anode has been discharged before continuing. ***Failure to discharge the anode could result in serious injury.*** Also, if you discharge the Macintosh CRT to the metal chassis, the logic board may be destroyed. ***You must discharge to the ground lug!***

4. Remove the 128K/512K Macintosh logic board. Using an IC extractor, remove the two Revision D ROMs. ROM HI is at location D5, and ROM LOW is at location D8. (Refer to Figure 2, Macintosh 128K/512K Logic Board.)
5. Install the two ROMs in the appropriate locations on the **new** logic board: ROM HI (P/N 342-0341) at location D5, ROM LOW (P/N 342-0342) at location D8. (Refer to Figure 3, Macintosh Plus 1 Megabyte Logic Board.) There is a notch at one end of each ROM. This notch should face the front of the machine on installation.
6. Install the **new** Macintosh logic board with the ROMs. Install the **new** RFI shroud and the **new** rear housing.
7. Run *MacTest* to verify that the machine is still working correctly.
8. Return the old logic board (with no ROMs), the old RFI shroud, and the old rear housing to Apple.

□ SPECIAL PROBLEMS

Alternate Chassis Screw Sizes

Some Macintosh systems have been shipped with non-standard chassis screws. The standard Macintosh uses three 2.9 x 10 mm screws to attach the power/sweep board to the chassis, and one 2.9 x 6 mm screw to attach the ground lug to the chassis. The non-standard systems use one of the following types of screw for both the board and the ground lug:

- #6 x 3/8" Type A sheet metal screw, Phillips pan head, with external tooth start washer attached, steel, with zinc or cad plating
- #4-40 x 3/8" machine screw

To determine which screw is needed, compare the screw holes with the figures below. Systems with pem nuts or nutserts (Figures 4 and 5) use the machine screw. Systems without them (Figure 6) use the sheet metal screw.

These screws are available at any hardware store.

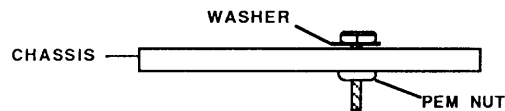

FIGURE 4

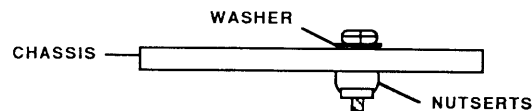

FIGURE 5

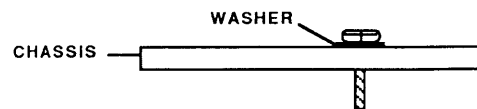

FIGURE 6

800K Drive Exchange Compatibility

There are three series of 800K drive mechanisms. All three mechanisms can be used as an internal drive, but only with the cable specified below. If you do not use the correct cable, the drive will not work correctly.

<i>Series Number</i>	<i>Cable Needed</i>
MFD-51W-03 (Red on Silver Label)	Yellow
MFD-51W (Black on Silver Label)	Red
51W-10 (Black on Silver Label)	Red

For additional information refer to the *Disk Drives* tab.

800K Disk Ejection Problems

Whenever a disk from an internal or external 800K drive does not fully eject, the user must push the disk back in and attempt to eject it electronically.

WARNING: *If the disk becomes "frozen" and does not fully eject, the user must not force the disk by pulling it out from the drive. Using force may result in damage to the mechanism.*

The following three ways of ejecting the disk should be tried:

1. Hold down the <Shift> and <Command> keys and press 1 (for the internal drive) or 2 (for the external drive).
2. Pull down the **File** menu and select **Eject**. Attempt this two or three times.
3. As a last resort, insert a paper clip in the pin hole located beneath and to the right of the slot where the disk is inserted.

The following factors can also affect the insertion and ejection of a disk:

- A disk should be inserted by pressing the disk gently into the drive. Avoid grasping and pushing the disk, as this may cause the disk to go in only part way and stop. If this happens, the user should attempt to eject the disk as described above.
- Disks with three or more labels may not slide easily into and out of the disk slot in the Macintosh case.

Technicians should also be careful when removing or installing a disk drive mechanism. If the disk opening in the disk drive mechanism is not properly centered, binding or friction may cause ejection problems. If the internal mounting bracket is warped or bent, the drive will not align properly with the bezel and the mounting bracket will need to be exchanged. Refer to Section 2, Take-Apart, for the proper installation procedure.

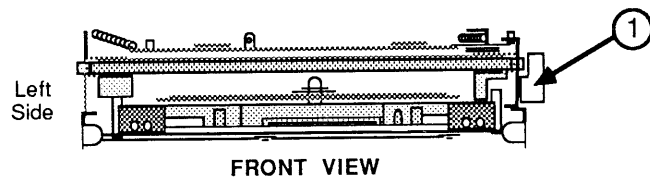

FIGURE 7

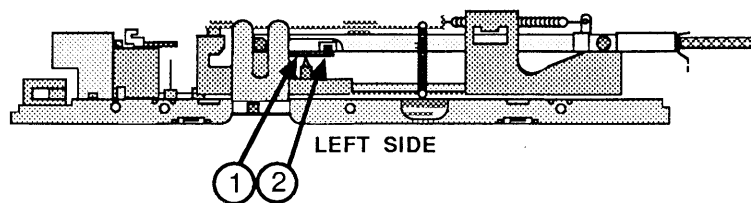

FIGURE 8

*Removing
Disks That
Will Not Eject*

If a disk becomes "jammed" in a customer's disk drive, use the following procedure to remove it before you return the disk drive.

1. Remove the disk drive (refer to Section 2, Take-Apart).
2. Place the disk drive and RFI shield assembly upside down on a flat surface.
3. Remove the four screws securing the disk drive mechanism to the RFI shield.
4. Remove the disk drive mechanism from the RFI shield.
5. Place the disk drive mechanism on a flat surface, with the printed circuit board facing down and the disk opening facing you (Figure 7).

If the disk is not already fully inserted into the disk drive, push it in until it is properly seated.

6. Press the eject lever at the right side of the disk drive (Figure 7, #1).

Turn the disk drive so that the left side is facing you.

7. Locate the small arm with a cylindrical cog at its end. This arm is located near the left-to-right center of the drive mechanism (Figure 8, #1). The cog will be caught in the half-moon depression of the disk case.
8. Insert a small screwdriver at the position shown in Figure 8, #2, and gently move the arm away from the disk until the disk pops forward slightly. Remove the disk from the disk drive.
9. Return the defective disk drive to Apple and follow the instructions in Section 2, Take-Apart, to align the new disk drive with the front bezel.

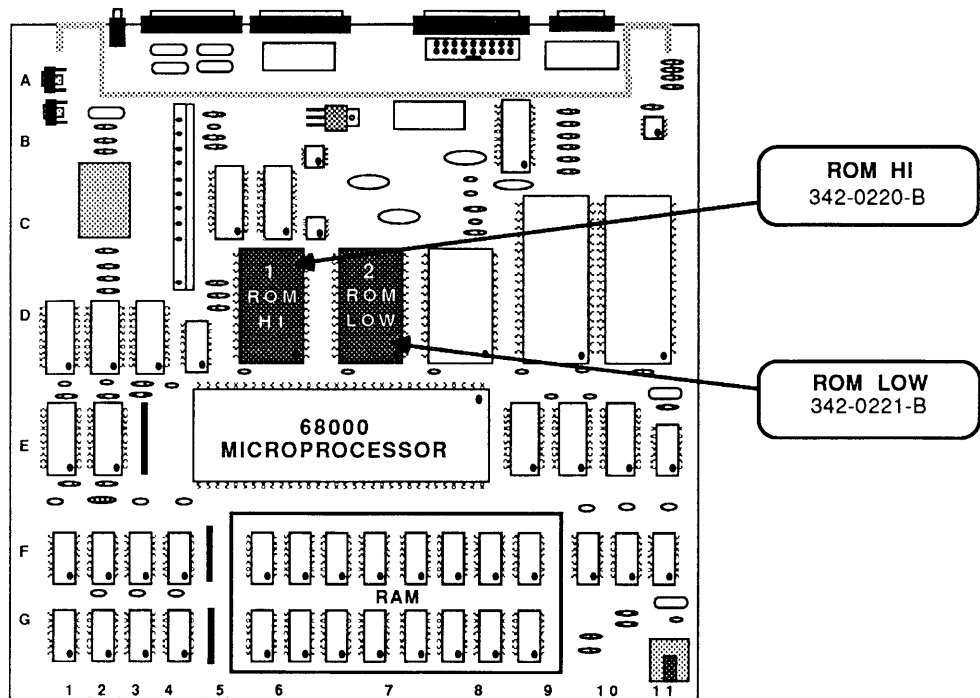

FIGURE 9

Logic Board ROM Upgrade and 400K Drives

Current 400K disk drives contain a new stepper motor, which may require the replacement of the two boot ROMs on older Macintosh logic boards (both 128K and 512K). Both of these ROMs are socketed. The new ROMs are compatible with both the new and old stepper motors.

The 128K/512K Macintosh should have ROM HI 342-0220-B at location D5, and ROM LOW 342-0221-B at location D8. If these ROMs are not installed, you need to upgrade the logic board by replacing the boot ROMs.

Installation Procedures

1. Power off the Macintosh and remove the power cable from the machine.
2. Remove the cover and discharge the CRT (refer to Section 2, Take-Apart).

WARNING: Make sure the anode has been discharged before continuing. Failure to discharge the anode could result in serious injury. Also, if you discharge the Macintosh CRT to the metal chassis, the logic board may be destroyed. You must discharge to the ground lug!

3. Remove the Macintosh logic board. Referring to Figure 9, locate the two ROMs and verify that the old ROMs are installed.
4. Using an IC extractor, remove the ROMs and place them on a piece of antistatic foam.
5. Install the new ROMs in the appropriate location [ROM HI (P/N 342-0220-B) at location D5, ROM LOW (P/N 342-0221-B) at location D8]. There is a notch at one end of each ROM. This notch should face the front of the machine on installation.
6. Reinstall the Macintosh logic board.
7. Replace the back cover.
8. Run *MacTest* to verify that the machine is still working correctly.

□ MACINTOSH PLUS RAM UPGRADES

Introduction

The Macintosh Plus may be configured in three ways: 1 MB (which is standard) and 2.5 MB or 4 MB (which are both upgrades or expansions). The expansions must follow strict guidelines that involve modifying the Macintosh logic board and installing the SIMMs.

Note: For installation purposes, the SIMMs are labeled Bank A (Figure 10, #3) and Bank B (Figure 10, #4). Each bank or row is composed of two slots, and both slots must have a SIMM installed.

Note: When removing SIMMs from the logic board, use the SIMM removal tool. See *You Oughta Know*.

Logic Board Configurations

There are two resistors, located on the upper-left side of the logic board, that give the Macintosh important information about the size of the installed SIMMs.

- If you have more than one bank of SIMMs installed, the ONE ROW, R9 (Figure 10, #1) resistor should be cut out using insulated wire cutters.
- If you have 256K SIMMs in both Bank A (Figure 10, #3) and Bank B (Figure 10, #4), the resistor marked 256K BIT, R8 (Figure 10, #2) must be installed.
- If either bank has 1 MB SIMMs, resistor R8 (256K bit) must be removed.

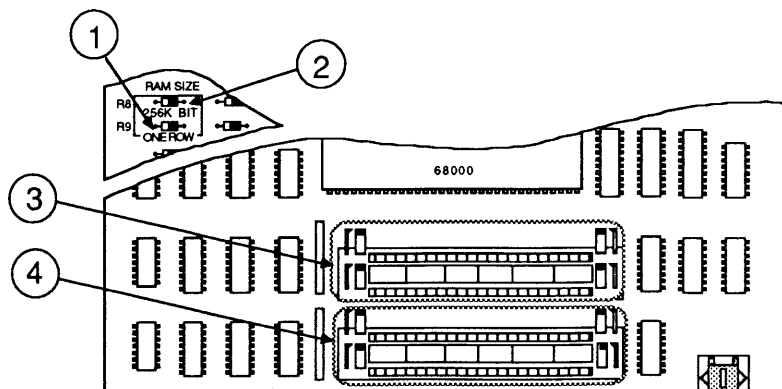

FIGURE 10

The following chart summarizes the various SIMM configurations that the Macintosh Plus and the system software support.

RAM Bank A (Figure 11 #1) Bank B (Figure 11 #2)

1 MB	Two 256K SIMMs	Two 256K SIMMs
2.5 MB	Two 1 MB SIMMs	Two 256K SIMMs
4 MB	Two 1 MB SIMMs	Two 1 MB SIMMs

IMPORTANT: Other configurations, such as a single SIMM or a pair of differently sized SIMMs, will not function correctly.

Note: For further information on the SIMMs currently available for the Macintosh Plus, see the standalone chart titled "🍏 Quick Reference: SIMM Compatibility."

The following chart summarizes the amount of RAM installed in various resistor configurations.

<u>RAM</u>	<u>256K BIT (R8)</u>	<u>ONE ROW (R9)</u>
1 MB	Present	Removed
2.5 MB	Removed	Removed
4 MB	Removed	Removed

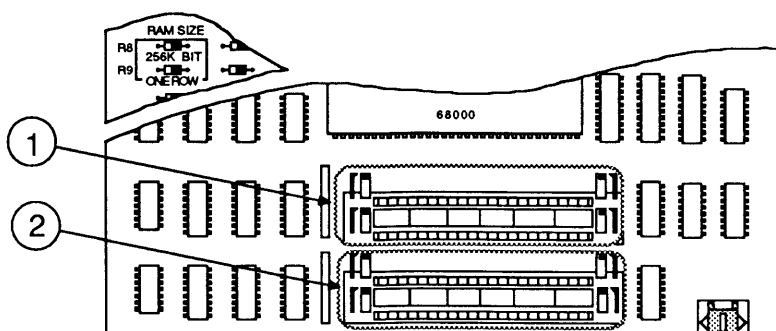

FIGURE 11

□ ROM VERSION COMPATIBILITY

ROM Upgrades for Enhanced Macintosh Systems

Since March, 1987, the Macintosh 512K enhanced system, the Macintosh Plus, and the 800K disk drive upgrade kit have been shipped with a new set of high-boot and low-boot ROMs. These ROMs correct SCSI device problems that were being experienced with older ROMs. The new ROMs are fully compatible with 512K systems, but you **must not mix old and new ROMs**.

The following list gives the part number and the version letter of the old and new ROMs.

	Old ROMs	New ROMs
High Boot:	342-0341-A 342-0341-B	342-0341-C
Low Boot:	342-0342-A	342-0342-B

Replacing 512K Logic Boards

The 512K logic board (P/N 661-96236) is shipped with a high-boot ROM (P/N 342-0220) and a low-boot ROM (P/N 342-0221) that support only the 400K disk drive. When the 512K logic board is used to replace a defective 512K enhanced system logic board, or a defective 512K system logic board with a 800K disk drive, you must replace its ROMs with ROMs from the customer's logic board. The customer's ROMs, which support 800K disk drive systems, have part numbers 342-0341 (high-boot ROM) and 342-0342 (low-boot ROM).

Macintosh and Macintosh Plus

Section 7 – Illustrated Parts List

□ CONTENTS

- 7.3 Macintosh External Housing (Figure 1)
- 7.5 Macintosh Plus Chassis & Power Supply (Figure 2)
- 7.7 Macintosh Exploded View (Figure 3)
- 7.9 Macintosh Keyboard Assembly (Figure 4)
- 7.11 Macintosh Numeric Keypad Assembly (Figure 5)
- 7.13 Macintosh Plus Rear Housing (Figure 6)
- 7.15 Macintosh Plus—Exploded View (Figure 7)
- 7.17 Macintosh Plus Keyboard Assembly (Figure 8)
- 7.19 Service Packaging, 800K/1.4 MB Drives (Figure 9)

The figures and lists in this section include all piece parts that can be purchased separately from Apple for the Macintosh, along with their part numbers. These are the only parts available from Apple. Refer to your *Apple Service Programs* manual for prices.

Note: Only items unique to the Macintosh Plus are called out on Figures 6, 7, and 8.

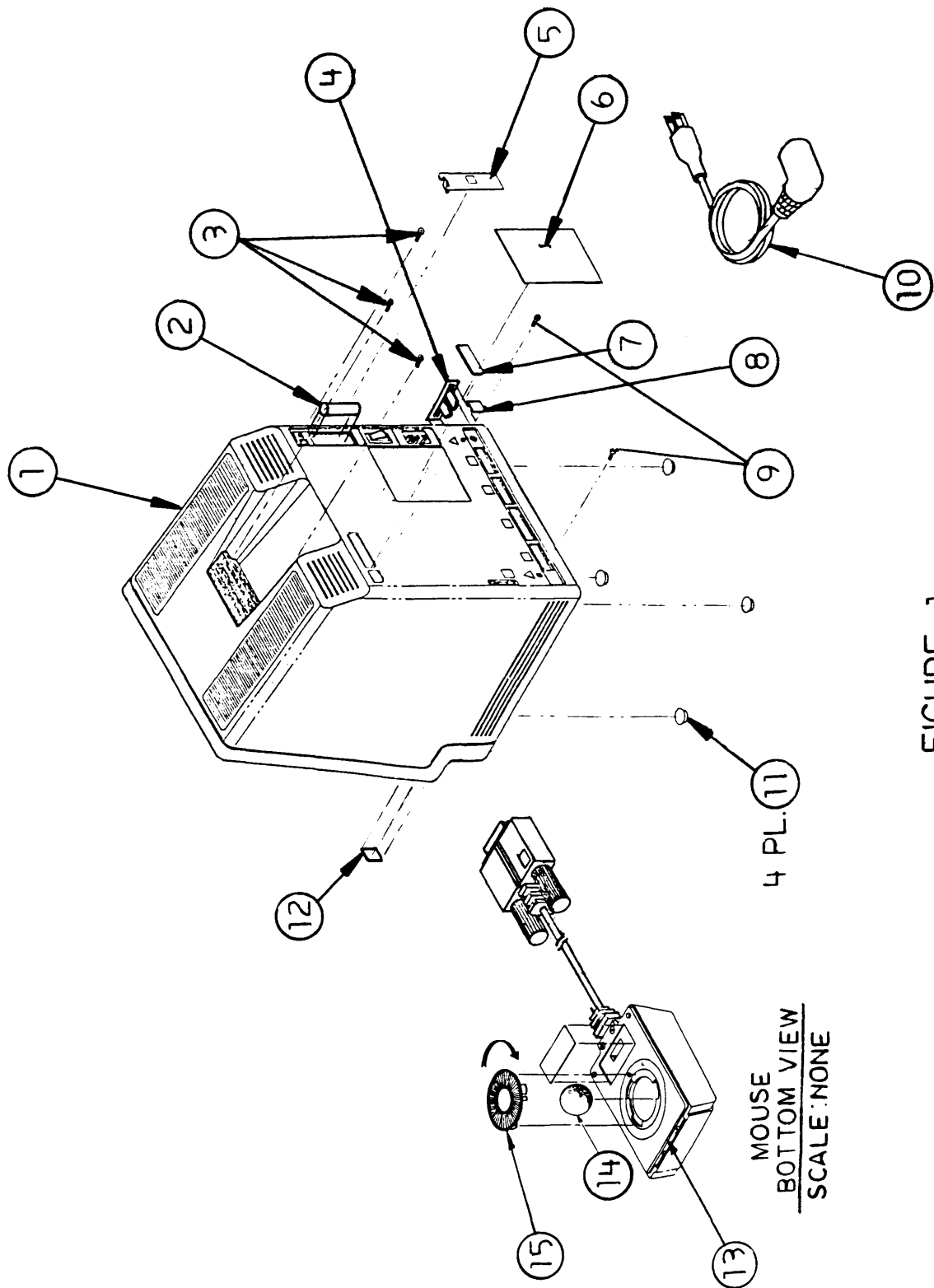

FIGURE 1

□ MACINTOSH EXTERNAL HOUSING (Figure 1)

<u>Item</u>	<u>Part No.</u>	<u>Description</u>
1	630-5139	Rear Housing with Label
2	742-0003	Battery, Alkaline, 4.5 V
3	426-1007	Screw, Tap, M 4.22 x 1.41 x 16, Torx, Zinc
4	815-0737	Reset/Interrupt Switch, Beige
	815-0763	Reset/Interrupt Switch, Smoke
5	815-0938	Macintosh Battery Door, Beige
	815-0971	Macintosh Plus Battery Door, Platinum
6	825-4018	Agency Approval Label
	825-1014	Agency Approval Label, 512K Enhanced
7	825-0742	Macintosh Label
	825-1065	Macintosh Signature 512K Label
8	825-0613	Logo Label (Housing)
9	435-5002	Screw, Tap, 8-32 x .625 Fill, Torx, Black Zinc Oxide
10	590-0138	Power Cable, Beige
	590-0131	Power Cable, Smoke
11	865-0051	Macintosh Foot
12	825-0547	Logo Label (Bezel)
13	661-96155	Macintosh Mouse
	661-0400	Apple Mouse, Platinum
14	699-8001	Rubber-Coated Mouseball
15	815-0409	Mouseball Retainer

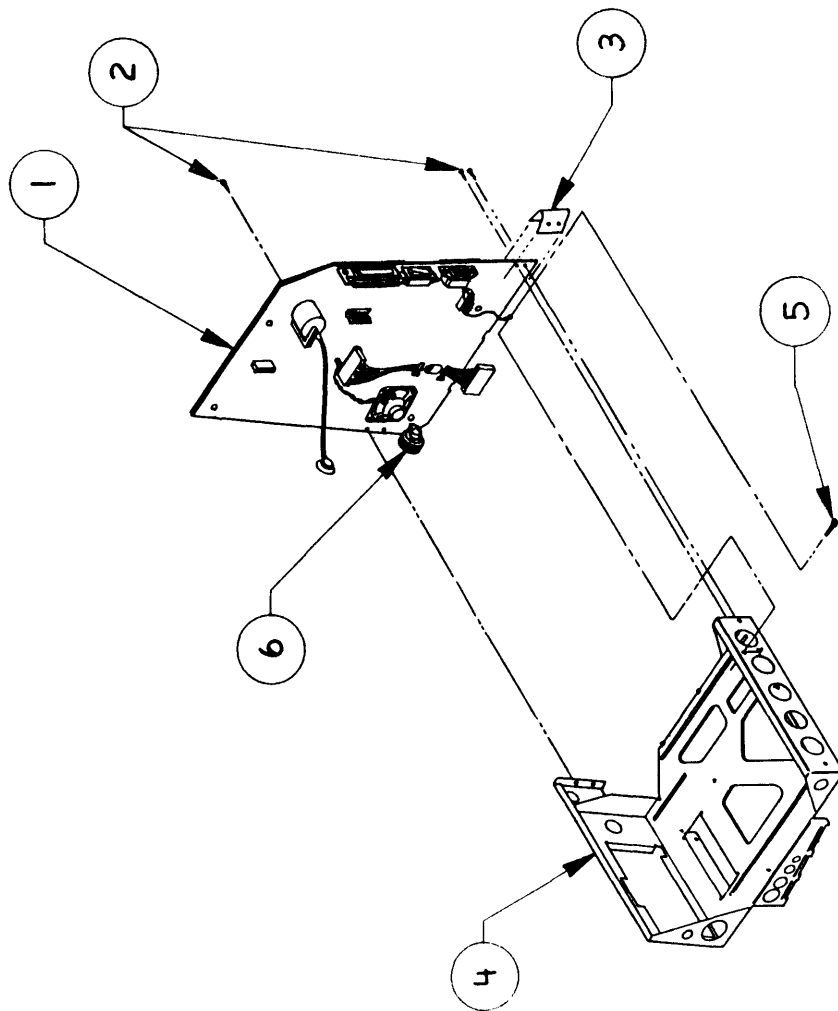

FIGURE 2

**□ MACINTOSH / MACINTOSH PLUS—CHASSIS AND POWER
SUPPLY (Figure 2)**

<u>Item</u>	<u>Part No.</u>	<u>Description</u>
1	661-0461	Power Supply, Beige
	661-0462	Power Supply, Platinum
	661-76214	Power Sweep Board, 220 V
2	470-2101	Screw, 2.9 x 10 mm
3	805-0576	Lower Ground Clip
4	805-0766	Macintosh Chassis
5	490-0002	Screw, Tap, 6-32 x .375 (Chassis Grounding)
6	865-0029	Brightness Knob, Smoke

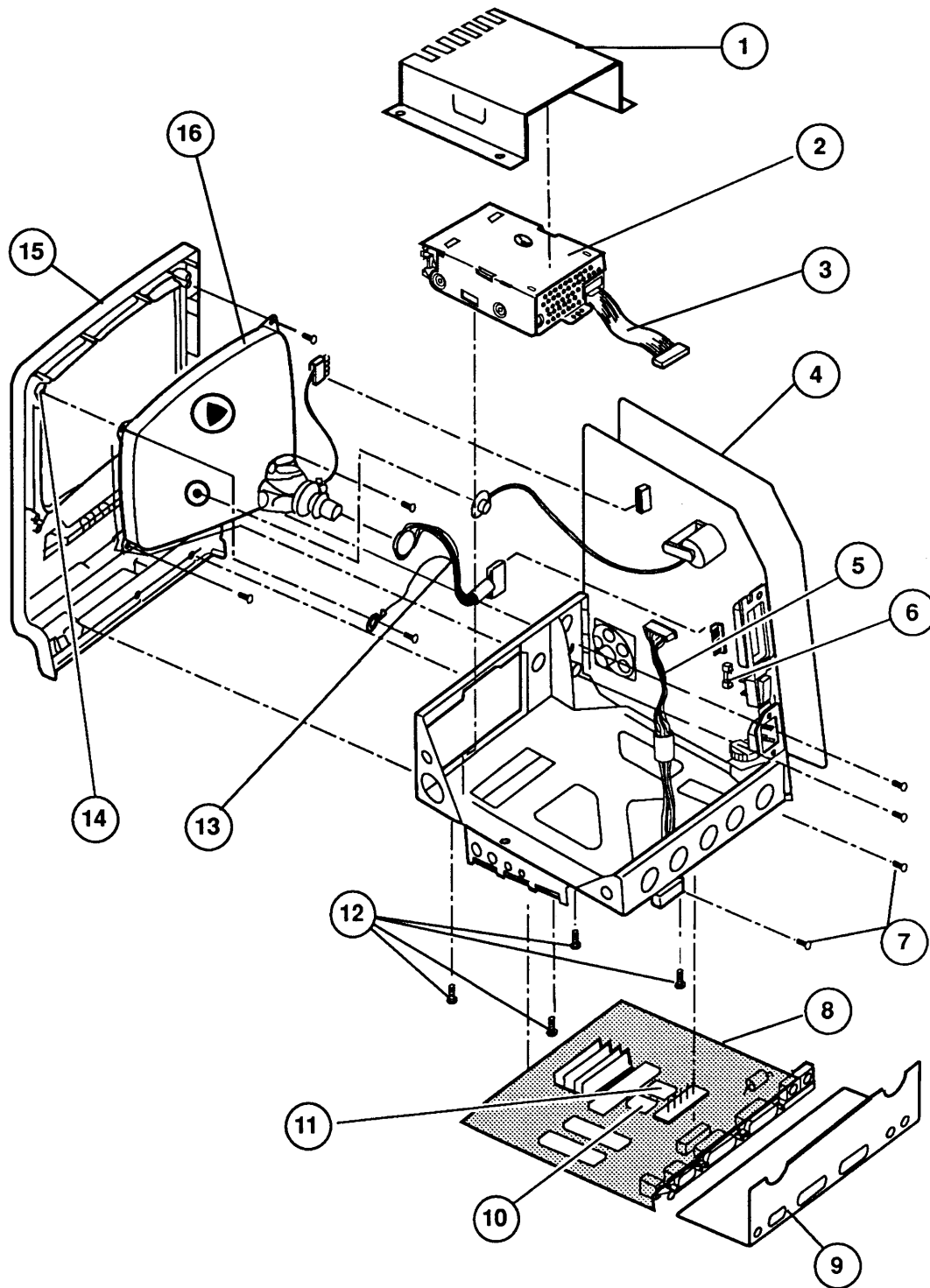

FIGURE 3

□ MACINTOSH – EXPLODED VIEW (Figure 3)

<u>Item</u>	<u>Part No.</u>	<u>Description</u>
1	805-0765	Shield for Internal Drive
	805-0217	Shield for Internal 800K Drive (512K enhanced)
2	661-76156	400K Mechanism, Apple 3.5 Drive
	661-0345	800K Mechanism, Apple 3.5 Drive (512K enhanced)
3	590-0167	Cable, Internal 3.5-Inch Drive (red striped)
	590-0437	Cable, Internal 3.5-Inch Drive (yellow striped)
4	725-0011	Insulator Shield (back of power supply)
5	590-0184	Cable, Power Supply to Logic Board
6	740-0300	Fuse, U.S. Power Supply, 2.5 A 250 V
	740-0060	Fuse, Int'l Power Supply, 1.6 A 250 V
7	426-1001	Screw, Tap, M 4.22 x 1.41 x 13 (CRT and chassis)
8	661-96236	Logic Board*
9	805-0577	RFI Shroud
10	661-0221	ROM, Low, Macintosh with 400K Floppy**
11	661-0220	ROM, High, Macintosh with 400K Floppy**
12	462-3100	Screw, M 3 x .5 x 6
13	590-0160	CRT Socket Cable
14	725-0018	Mylar Washer
15	810-0373	Front Bezel
16	076-0103	CRT and Yoke Assembly

* If the logic board fails, refer to Section 6, Additional Procedures, for instructions.

Use these ROMs on 128K and 512K logic boards that have **not been upgraded with ROMs that support an 800K disk drive.

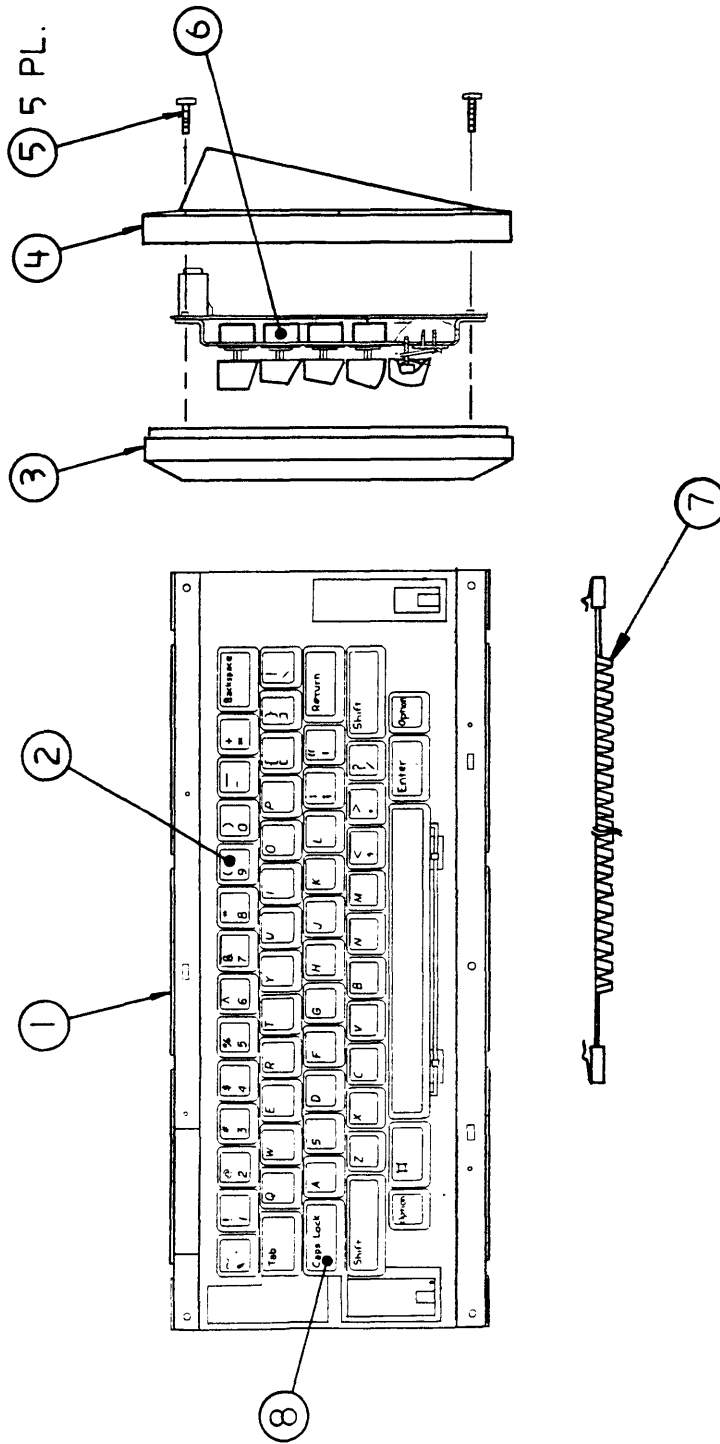

FIGURE 4

□ MACINTOSH—KEYBOARD ASSEMBLY (Figure 4)

<u>Item</u>	<u>Part No.</u>	<u>Description</u>
1	661-0322	Keyboard, Beige (replacing part number 661-96154)
2	658-7039	Keycap Set
3	815-0728	Keyboard Top Case
4	815-0754	Keyboard Bottom Case
5	430-1025	Screw, Tap 2.20 x 6.25 (Keyboard Case)
6	705-0070	Alps Long-Stem Keyswitch, Macintosh/ Macintosh Plus*
7	590-0144	Keyboard/Keypad Cable, Beige
	590-0170	Keyboard/Keypad Cable, Smoke
8	705-0077	Alps Alpha Lock Keyswitch, Macintosh/ Macintosh Plus*

Note: Keycaps are not available for international keyboards. For Macintosh Plus keycap set, see Figure 8, "Macintosh Plus Keyboard Assembly."

*Refer to keyswitch identification in *Appendix* section.

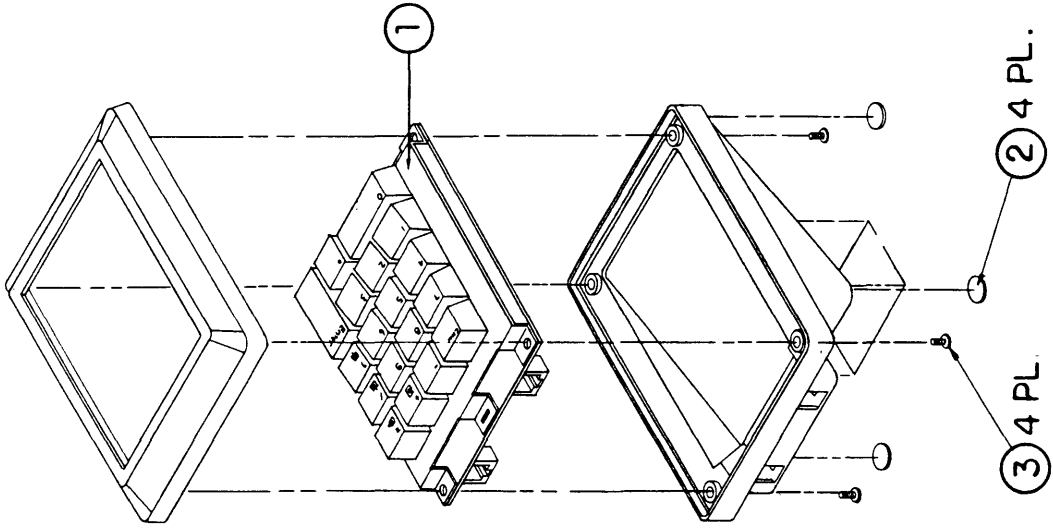

FIGURE 5

□ **MACINTOSH – NUMERIC KEYPAD ASSEMBLY (Figure 5)**

<u>Item</u>	<u>Part No.</u>	<u>Description</u>
1	658-4045	Keypad Assembly
2	865-0051	Macintosh Foot
3	430-1025	Screw, Tap, 2.2 x 6.25

Note: The keyswitch used on the Macintosh Numeric Keypad is the same as that on the Macintosh Keyboard: Alps Longstem Keyswitch (p/n 705-0070). See Appendix A for illustration.

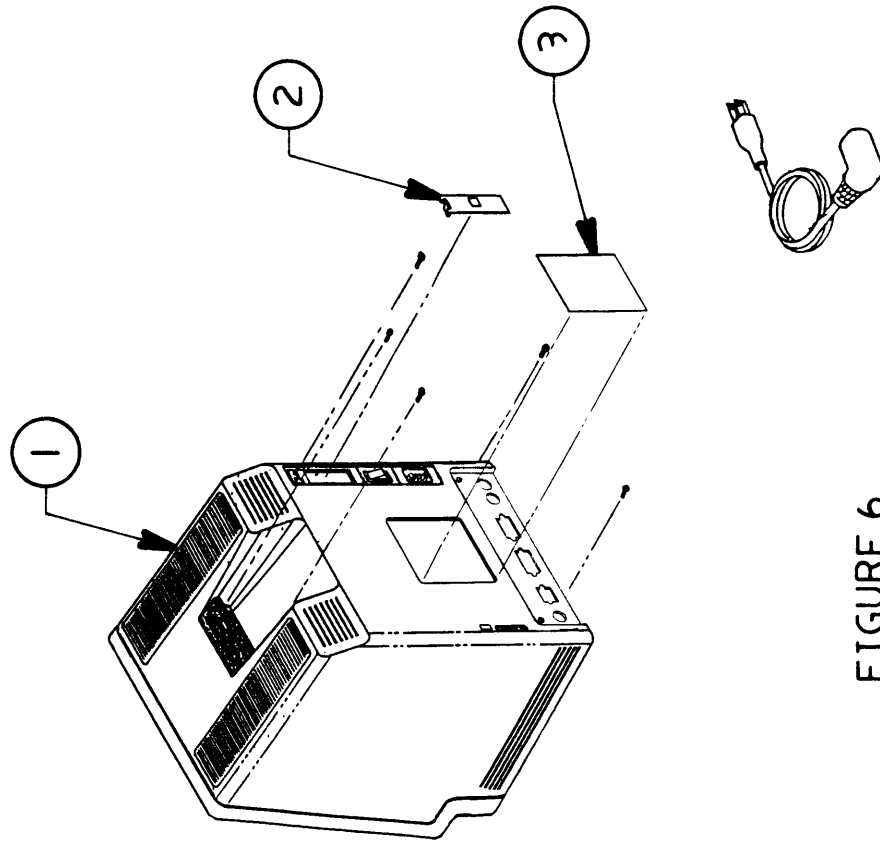

FIGURE 6

□ **MACINTOSH PLUS – REAR HOUSING (Figure 6)**

<u>Item</u>	<u>Part No.</u>	<u>Description</u>
1	630-5211	Rear Housing, Beige
	630-5235	Rear Housing, Platinum
2	815-0938	Battery Door, Beige
	815-0971	Battery Door, Platinum
3	825-1254	Agency Approval Label, Beige
	825-1345	Agency Approval Label, Platinum

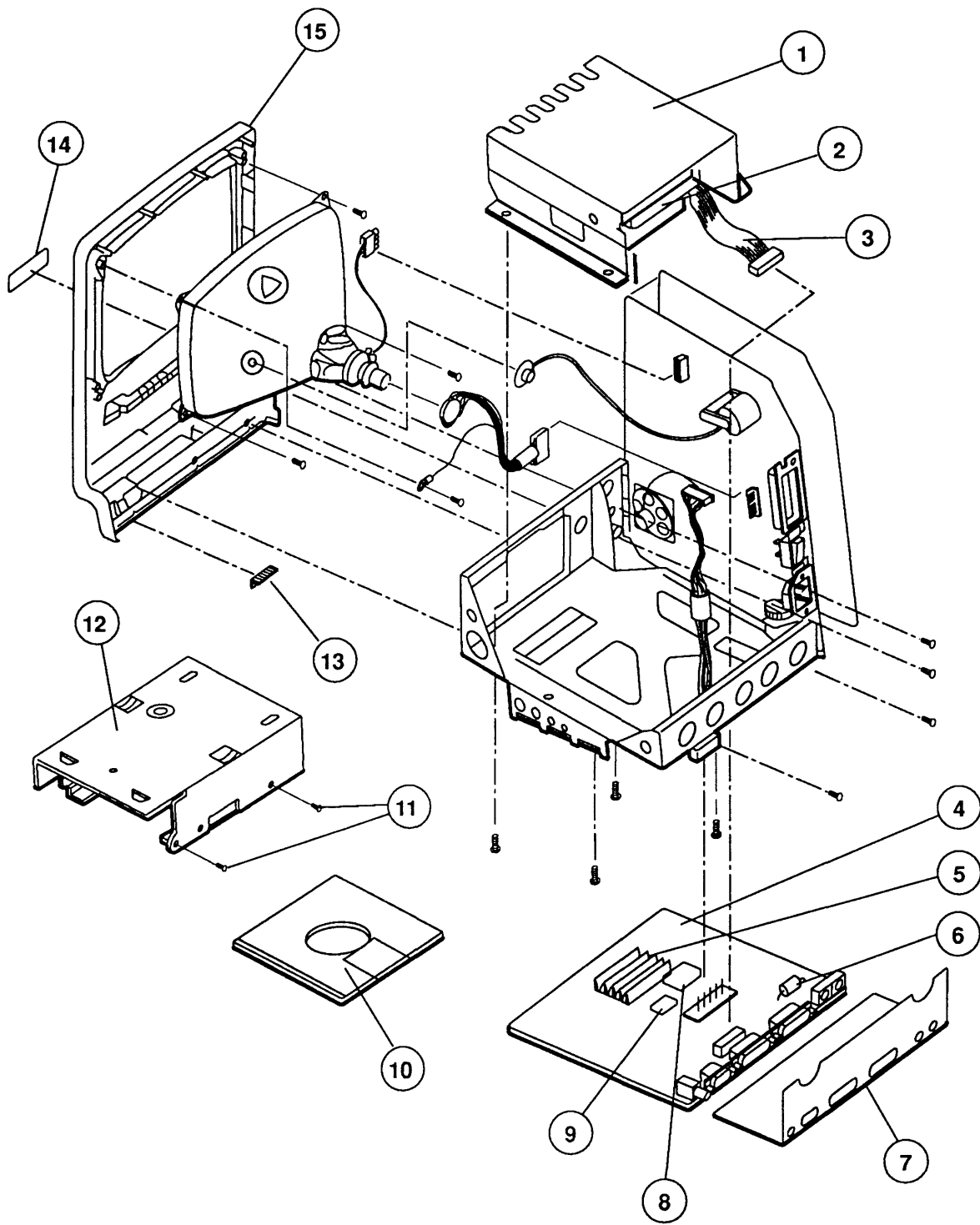



FIGURE 7

□ **MACINTOSH PLUS – EXPLODED VIEW (Figure 7)**

<u>Item</u>	<u>Part No.</u>	<u>Description</u>
1	805-0217	Shield for Internal Drive
2	661-0345	Drive Mechanism, 800K
3	590-0167	Cable, Internal 3.5-Inch Drive (red stripe)
	590-0437	Cable, Internal 3.5-Inch Drive (yellow stripe)
4	661-0525	Logic Board (without RAM; replaces part number 661-0321)
5	661-0402	SIMM, 256K, 120 ns
	661-0403	SIMM, SOJ, 1 MB, 120 ns
	661-0494	SIMM, DIP, 256K, 120 ns
	661-0519	SIMM, SOJ, 256K, 80 ns
	661-0520	SIMM, SOJ, 1 MB, 80 ns
6	101-4151	Resistor, 150 Ohms, 1/4 W, ±5%
7	805-5047	RFI Shroud
8	661-0633	ROM, Low
9	661-0632	ROM, High
10	003-0003	Packing Disk, 2-sided (for transporting)
11	462-3401	Screw, M 3 x 6 (with two washers)
12	805-5050	Shipping Fixture, 1.4 MB Drive Mechanism
13	805-0910	Ground Clip
14	825-1256	Logo Plate Label
15	810-0379	Front Bezel

IMPORTANT: Refer to the  Quick Reference: SIMM Compatibility chart for SIMM compatibility. Follow this chart carefully! Some SIMMs may falsely appear to be interchangeable.

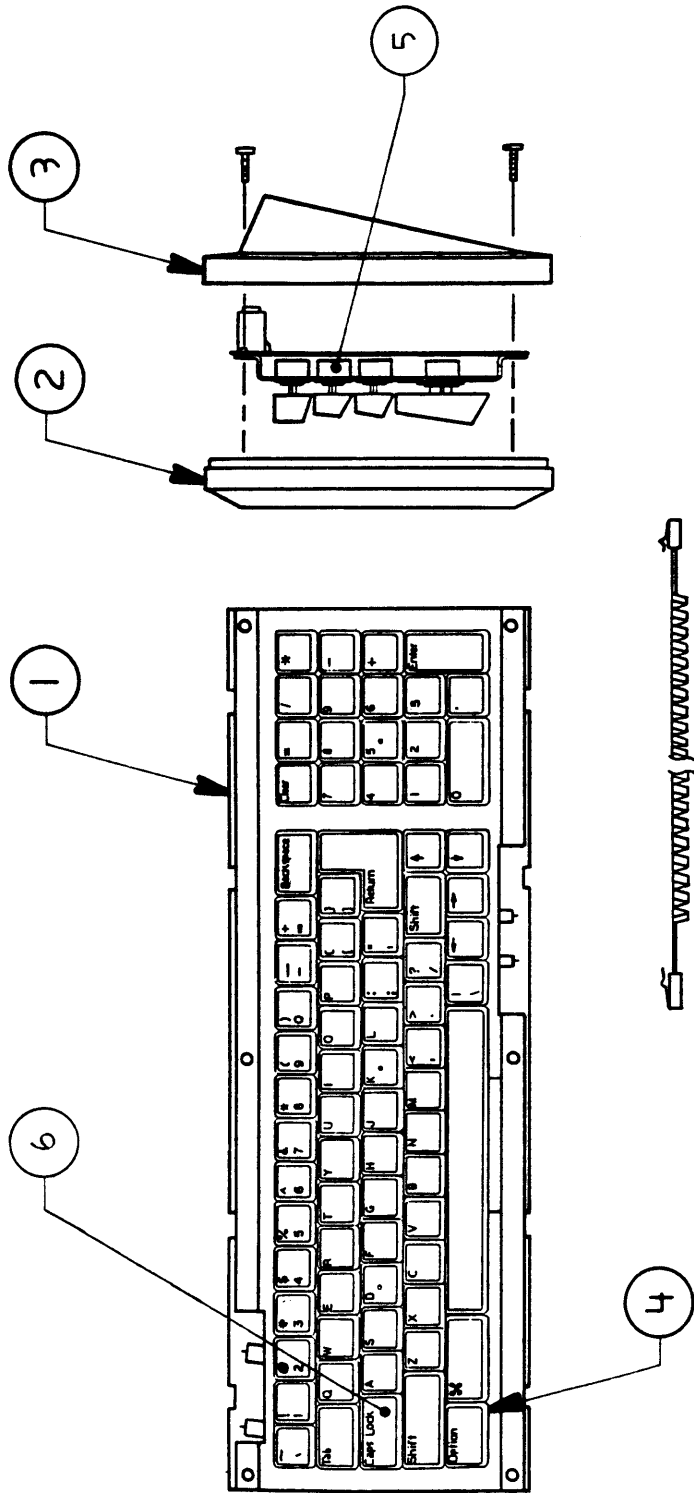

FIGURE 8

□ MACINTOSH PLUS – KEYBOARD ASSEMBLY (Figure 8)

<u>Item</u>	<u>Part No.</u>	<u>Description</u>
1	661-0322	Macintosh Plus Keyboard, Beige (with cable)
	661-0416	Macintosh Plus Keyboard, Platinum (with cable)
	C661-0416	Macintosh Plus Keyboard, Platinum, French Canadian
	D661-0416	Macintosh Plus Keyboard, Platinum, German
	E661-0416	Macintosh Plus Keyboard, Platinum, Spanish
	F661-0416	Macintosh Plus Keyboard, Platinum, French
	T661-0416	Macintosh Plus Keyboard, Platinum, Italian
2	815-0936	Top Cover, Macintosh Plus K/B, Beige
	815-0983	Top Cover, Macintosh Plus K/B, Platinum
3	815-0937	Bottom Cover, Macintosh Plus K/B, Beige
	815-0984	Bottom Cover, Macintosh Plus K/B, Platinum
4	658-5186	Macintosh Plus Keycap Set, Beige
	658-5190	Macintosh Plus Keycap Set, Smoke
5	705-0104	Mitsumi Keyswitch*
	705-0070	Alps Long-Stem Keyswitch, Macintosh/ Macintosh Plus*
6	705-0044	Mitsumi Locking Keyswitch*
	705-0077	Alps Alpha Lock Keyswitch, Macintosh/ Macintosh Plus*

*Refer to keyswitch identification in Basics section.

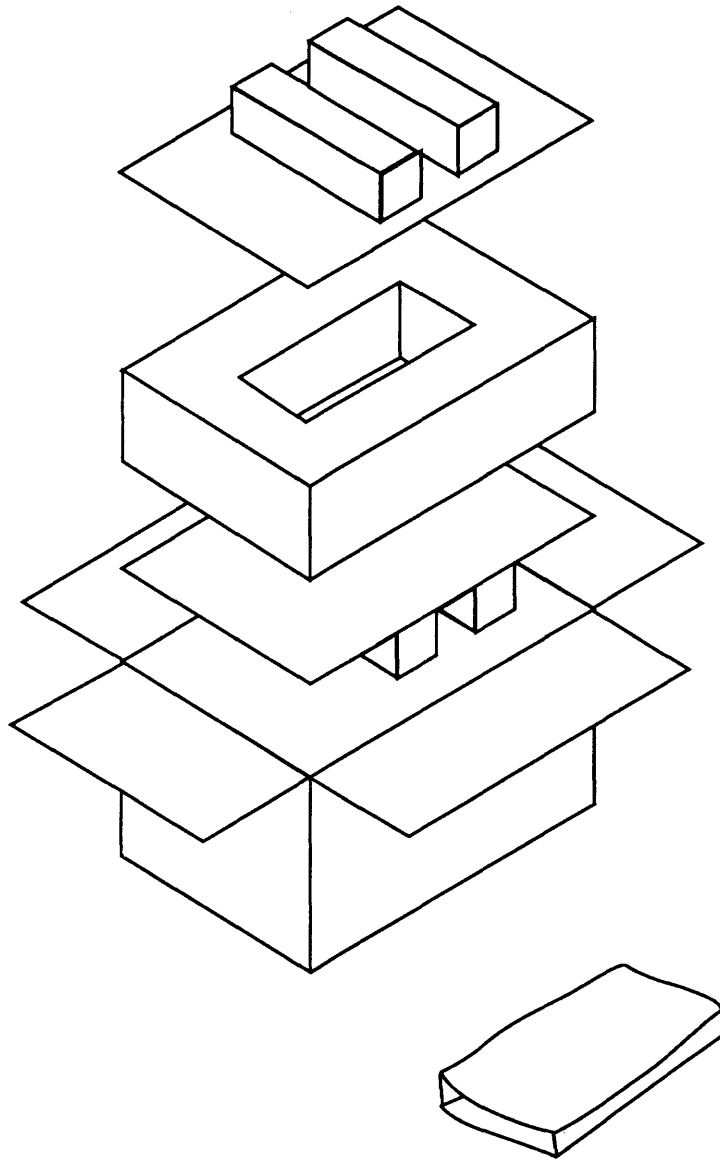

FIGURE 9

□ SERVICE PACKAGING, 800K/1.4 MB DRIVES (Figure 9)

<u>Item</u>	<u>Part No.</u>	<u>Description</u>
-	602-0210	Service Packaging, 800K/1.4 MB Drives

(

(

(

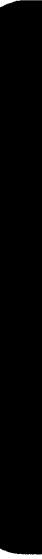



Macintosh SE and Macintosh SE/30

Technical Procedures

□ TABLE OF CONTENTS

Section 1 – Basics	1.2	Product Description
	1.2	Macintosh SE Features
	1.3	Macintosh SE/30 Features
	1.6	FDHD Disk Drive
	1.7	Connector Identification
	1.10	Internal Expansion Connectors
	1.11	Theory of Operation
	1.11	Introduction
	1.11	Main Logic Board
	1.14	Power Supply
	1.14	Analog Board
	1.14	CRT and Video Board
	1.15	Disk Drive(s)
	1.15	SCSI Hard Disk
	1.15	Apple Desktop Bus Keyboard and Mouse
	1.16	Care and Handling
Section 2 – Take-Apart	2.2	Cover
	2.5	Discharging the Cathode-Ray Tube (CRT)
	2.5	Discharge Procedure
	2.7	Anode Cap
	2.8	Analog Board and Power Supply
	2.14	Main Logic Board
	2.16	Identifying Macintosh SE Logic Boards
	2.22	SIMMs
	2.25	Video Board
	2.28	Cathode-Ray Tube (CRT)
	2.31	Internal SCSI Hard Disk Drive
	2.31	Identifying 20SC Revision A and B Drives
	2.33	Removing the Drive From Its Carrier
	2.33	Replacing the Drive In Its Carrier
	2.35	LED Cable Assembly
	2.37	Upper Internal Disk Drive
	2.40	Lower Internal Disk Drive
	2.42	Fan Assembly
	2.46	Speaker, Front Bezel, and Slot Cover

**Section 3 –
Adjustments**

- 3.2 Yoke Adjustments
- 3.2 Introduction
- 3.2 Materials Required
- 3.3 Tilt Adjustment
- 3.3 Centering Ring Adjustment
- 3.4 Video Adjustments
- 3.4 Introduction
- 3.4 Materials Required
- 3.5 Adjustment Procedures

**Section 4 –
Diagnostics**

- 4.2 Introduction to MacTest SE and MacTest SE/30
- 4.2 Program Similarities
- 4.3 Program Differences
- 4.4 Making Backup Disks
- 4.4 Copying MacTest SE and MacTest SE/30 Disks
- 4.6 Running MacTest SE and MacTest SE/30
- 4.6 Materials Required
- 4.6 Starting MacTest SE and MacTest SE/30
- 4.8 Installing the Loopbacks
- 4.9 Using the MacTest SE and SE/30 Menus
- 4.14 Running the Tests
- 4.16 Introduction to AppleCAT SE and AppleCAT SE/30
- 4.17 Running AppleCAT SE and AppleCAT SE/30
- 4.17 Materials Required
- 4.17 Setting Up Test Station and UUT
- 4.20 Establishing Communication
- 4.22 Using the AppleCAT Menus
- 4.26 Running the Tests
- 4.28 Repair Confirmation Codes
- 4.29 SCSI Loopback Jumper Procedure
- 4.29 To Determine If a Jumper Is Needed
- 4.30 To Install the Jumper

**Section 5 –
Troubleshooting**

- 5.3 Introduction
- 5.3 General Information
- 5.3 How to Use the Symptom Chart
- 5.3 Things to Remember
- 5.4 Symptom Chart
- 5.4 Video Problems
- 5.6 Peripheral Problems
- 5.7 Drive Problems
- 5.8 SCSI Problems
- 5.9 Miscellaneous Problems
- 5.10 Isolating a Faulty Macintosh SE SIMM
- 5.12 Battery Verification
- 5.12 Introduction
- 5.12 Materials Required
- 5.12 Verification Procedure

**Section 6 –
Additional
Procedures**

- 6.3 Battery Replacement
- 6.3 Introduction
- 6.4 Battery Identification
- 6.5 Replacing Soldered Batteries (SE only)
- 6.7 Replacing Batteries in Battery Holders
- 6.8 SIMM Identification
- 6.8 Speed
- 6.8 1 MB SIMMs
- 6.9 256K SIMMs
- 6.10 Macintosh SE SIMM Upgrades
- 6.10 RAM Configurations
- 6.11 SIMM Arrangements
- 6.12 Logic Board Identification
- 6.14 Solder-Type Logic Board
- 6.15 Solder-Type Upgrades
- 6.17 Jumper-Type Logic Board
- 6.18 Jumper-Type Upgrades
- 6.20 Macintosh SE/30 SIMM Upgrades
- 6.20 RAM Configurations
- 6.20 SIMM Arrangements
- 6.21 SIMM Upgrades
- 6.24 Macintosh SE Chassis Tab Modification
- 6.24 Introduction
- 6.24 Modification Procedure
- 6.25 Chassis Assembly
- 6.25 Introduction
- 6.25 Assembly Procedure
- 6.26 Macintosh SE/30 Logic Board Upgrade
- 6.26 Introduction
- 6.26 Installation
- 6.29 FDHD Upgrade for the Macintosh SE
- 6.29 Introduction
- 6.29 Materials Required
- 6.29 Upgrade Procedure

**Section 7 –
SE-Bus PC Card**

This section has moved to *Apple PC 5.25 Drive*.

**Illustrated
Parts List**

IPL.3	Internal View (Figure 1)
IPL.5	Chassis Assembly (Figure 2)
IPL.7	External Rear Housing (Figure 3)
IPL.9	Front Bezel (Figure 4)
IPL.11	Logic Board – Macintosh SE (Figure 5)
IPL.13	Logic Board – Macintosh SE/30 (Figure 6)
IPL.15	Analog Board (Figure 7)
IPL.17	Shipping Fixture, 800K/1.4 MB Drives (Figure 8)
IPL.17	Dual Internal 800K Drives (Figure 9)
IPL.19	Internal HDA (Figure 10)

Note: The labels FDHD and FDHD/SuperDrive refer to the same product.

©Apple Computer, Inc., 1987-1991. No portion of this document may be reproduced in any form without the written permission of Apple Computer, Inc.

MacTest, FDHD, Apple Desktop Bus, and SuperDrive are trademarks of Apple Computer, Inc.

Macintosh, AppleCAT, AppleTalk, Apple, and the Apple logo are registered trademarks of Apple Computer, Inc.

MS-DOS is a registered trademark of Microsoft Corporation.

NuBus™ is a trademark of Texas Instruments.

Macintosh SE and Macintosh SE/30

Section 1 – Basics

□ CONTENTS

- 1.2 Product Description
- 1.2 Macintosh SE Features
- 1.3 Macintosh SE/30 Features
- 1.6 FDHD Disk Drive
- 1.7 Connector Identification
- 1.10 Internal Expansion Connectors
- 1.11 Theory of Operation
 - 1.11 Introduction
 - 1.11 Main Logic Board
 - 1.14 Power Supply
 - 1.14 Analog Board
 - 1.14 CRT and Video Board
 - 1.15 Disk Drive(s)
 - 1.15 SCSI Hard Disk
 - 1.15 Apple Desktop Bus Keyboard and Mouse
 - 1.16 Care and Handling

□ PRODUCT DESCRIPTION

Macintosh SE Features

The Macintosh® SE is an enhanced Macintosh Plus that supports internal and external customized expansion options. This Macintosh comes with 1 or 2 megabytes of RAM installed, with upgrades to 2.5 and 4 megabytes available. The system also contains an internal connector for expansion of the CPU bus, and provides the customer with a choice of two drive configurations:

- Two internal floppy disk drives
- One internal floppy disk drive and one internal, 20 MB or 40 MB SCSI hard disk drive

The high-density (1.4 MB) Apple Floppy Drive High Density (FDHD) disk drive is now the standard internal drive for all Macintosh SEs. Macintosh SEs sold before August 1989 were furnished with 800K internal disk drives.

The Macintosh SE supports the same peripherals as the Macintosh Plus, and will accept any keyboard or mouse that connects to the new Apple Desktop Bus™.

Macintosh SE Internal Features

The Macintosh SE includes these new or improved (as compared to the Macintosh Plus) internal features:

- 1 MB or 2 MB of RAM on repositioned, slanted Single In-line Memory Modules (SIMMs)
- New 256K ROM with modifications that support the Apple Desktop Bus and FDHD disk drive, and improve support of the Small Computer System Interface (SCSI) and AppleTalk
- Choice of internal 20 MB or 40 MB SCSI hard disk or second internal floppy disk drive
- Higher capacity 80-watt, wide-input-range power supply
- Fan for cooling
- Improved hardware handshaking on the SCSI port

- 96-pin Euro-DIN bus connector for internal expansion board or other I/O device (mounting holes provided)
- Swing-away logic board mounting to allow easy removal when an internal expansion board is installed
- One or two 1.4 MB, 3.5-inch FDHD disk drives
- SWIM disk controller chip, which replaces the IWM chip for controlling disk drives
- Long-life lithium battery for clock and RAM cache

Macintosh SE
External
Features

The Macintosh SE includes these external features:

- Two Apple Desktop Bus connectors that support the detached keyboard and mouse
- Snap-out door at the rear to support optional external I/O device

Macintosh SE/30
Features

The Macintosh SE/30, which is named for its 16-MHz 68030 microprocessor, is the next generation in the compact Macintosh SE line. The system is designed to provide increased performance (up to four times faster than the Macintosh SE), greater memory expandability (up to 8 megabytes), and larger hard disk capacity.

Macintosh SE/30
System
Configurations

The Macintosh SE/30 requires System 6.0.3 (or later) software. The system comes with 1 or 4 megabytes of RAM installed, and contains a 120-pin, vertically mounted expansion connector. The system also includes an internal FDHD disk drive. The customer can choose from three standard configurations:

- 1 MB of RAM and the FDHD drive
- 1 MB of RAM, FDHD drive, and 40 MB SCSI hard disk
- 4 MB of RAM, FDHD drive, and 80 MB SCSI hard disk

*Macintosh SE/30
System
Features*

The Macintosh SE/30 includes the following system features:

- 68030 microprocessor running at 16 MHz
- 68882 floating-point (numerics) coprocessor
- 1 MB or 4 MB of RAM on vertically mounted Single In-line Memory Modules (SIMMs)
- Eight repositioned SIMM sockets that can accommodate system expansion to 8 MB
- Single 32-bit, 120-pin expansion slot ("030 Direct Slot")
- Four 256K ROMs on a SIMM, upgraded to support the FDHD disk drive
- SWIM disk controller chip, which replaces the IWM chip for controlling disk drives
- Single 1.4 MB, 3.5-inch FDHD disk drive
- Choice of internal 40 MB or 80 MB SCSI hard disk drive
- Removable, seven-year lithium battery

*Macintosh SE/30
Logic Board*

At the heart of the Macintosh SE/30 is the *Motorola 68030 microprocessor* (Figure 1, #1). The 68030 is a true 32-bit microprocessor that is fully compatible with earlier 16- and 24-bit Macintosh microprocessors. This high-performance microprocessor runs at 16 MHz and is designed to handle paged memory management (incorporates the PMMU chip available for the Macintosh II logic board). A *68882 numerics coprocessor* (Figure 1, #2) enhances system performance by assisting with the floating-point calculations common in spreadsheet applications.

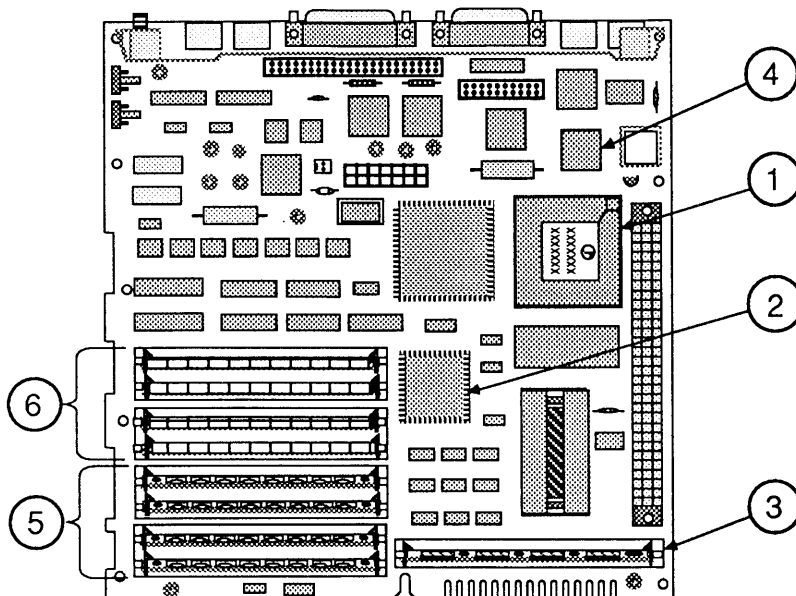

FIGURE 1

The Macintosh SE/30 logic board includes new *ROM chips* soldered on a SIMM board (Figure 1, #3). These ROM chips include code that supports the FDHD disk drive and SWIM disk controller chip. The *SWIM chip* (Figure 1, #4) enables the FDHD to read and write both GCR (Group-Coded Recording) data formats and MFM (Modified Frequency Modification) data formats.

RAM memory in the Macintosh SE/30 is packaged in 256K or 1 MB *Single In-line Memory Modules (SIMMs)*. The Macintosh SE/30 logic board has two banks of sockets that will hold up to eight SIMMs. Bank A (Figure 1, #5) and Bank B (Figure 1, #6) each contain four slots. Each bank, if used, must be filled with identical 256K or 1 MB SIMMs. The following chart illustrates RAM configurations that the Macintosh SE/30 will support:

<u>RAM</u>	<u>Bank A</u>	<u>Bank B</u>
1 MB	Four 256K SIMMs	Empty
2 MB	Four 256K SIMMs	Four 256K SIMMs
4 MB	Four 1 MB SIMMs	Empty
5 MB	Four 1 MB SIMMs	Four 256K SIMMs
8 MB	Four 1 MB SIMMs	Four 1 MB SIMMs



FDHD Disk Drive

The 3.5-inch, 1.4 MB FDHD disk drive is a high-density data storage system for both the Macintosh SE and the Macintosh SE/30. Special high-density, 3.5-inch media are required to take full advantage of the increased data storage capacity of the FDHD drive. Do not, however, use the high-density media in a 400K or 800K disk drive; such data will be unreliable. A simple rule-of-thumb is always to use media that are appropriate for the drive of lowest capacity; if you have both 800K and 1.4 MB disk drives, to be safe use only 800K media.

When used with the Apple File Exchange utility, the FDHD disk drive also enables Apple systems (GCR data format) to exchange data with MS-DOS systems (MFM data format). The FDHD disk drive can read/write and format 400K, 800K, and 1.4 MB Macintosh disks; 720K and 1.4 MB MS-DOS disks; and 800K ProDOS disks. When reading data in other formats, the Macintosh SE/30 first copies MS-DOS or ProDOS data files using the FDHD drive and Apple File Exchange utility, and then uses special file translators to convert the data from one application format to another. Some applications, such as Microsoft *Word*, perform their own translations.

Connector Identification

The external connectors on the Macintosh SE and Macintosh SE/30 are the same, but the internal connectors differ slightly between models. The following section shows the location of all external and internal connectors on the Macintosh SE and Macintosh SE/30.

Back Panel Connectors

The back panel of the Macintosh SE and Macintosh SE/30 has seven installed ports, and a slot for the installation of an additional expansion port. The number beside the port name below corresponds to the numbered arrow in Figure 2.

- #1 Apple Desktop Bus (mini DIN-4)
- #2 Apple Desktop Bus (mini DIN-4)
- #3 External drive port (DB-19)
- #4 SCSI port (DB-25)
- #5 Printer port (mini DIN-8)
- #6 Modem port (mini DIN-8)
- #7 Sound port (RCA phono jack)
- #8 Slot for optional expansion port

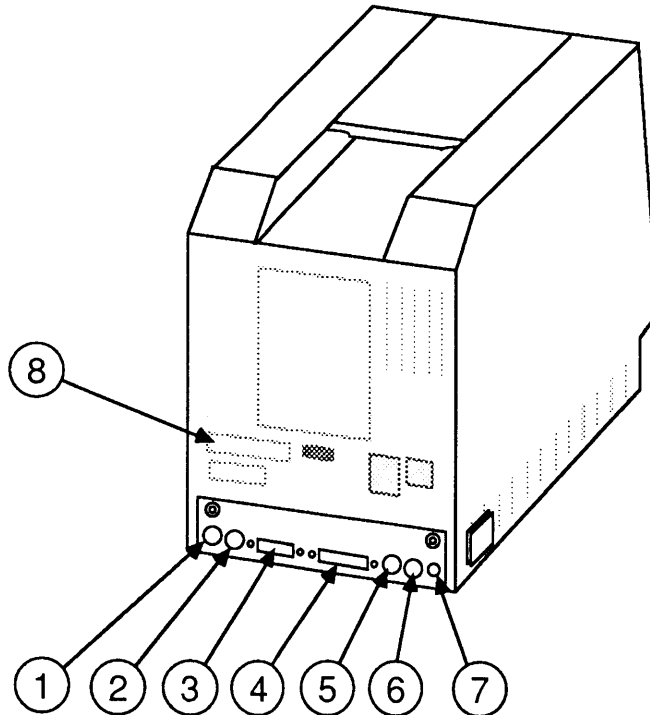

FIGURE 2

*Macintosh SE
Main Logic Board
Connectors*

There are six connectors on the Macintosh SE logic board. In the list below, the number beside the connector name corresponds to the numbered arrow in Figure 3.

- #1 Power connector
- #2 Connector for lower internal drive
- #3 Connector for upper internal drive
- #4 Internal hard disk SCSI 50-pin ribbon cable connector
- #5 Speaker connector
- #6 96-pin Euro-DIN expansion connector

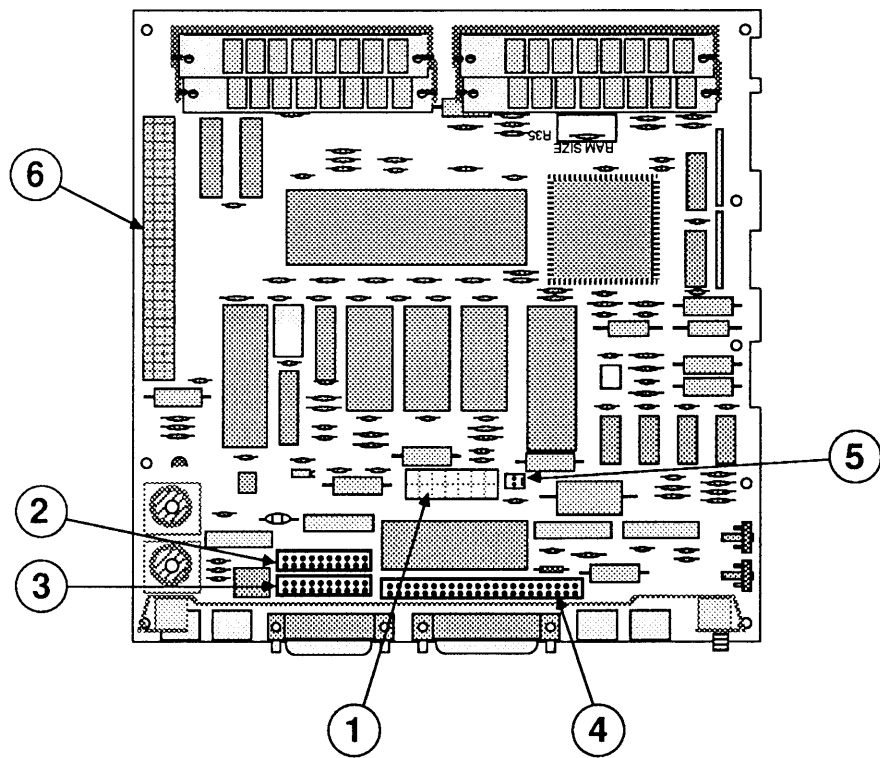

FIGURE 3

*Macintosh SE/30
Main Logic Board
Connectors*

There are five connectors on the Macintosh SE/30 logic board. In the list below, the number beside the connector name corresponds to the numbered arrow in Figure 4.

- #1 Power connector
- #2 Connector for internal 1.4 MB, 3.5-inch FDHD disk drive
- #3 Internal hard disk SCSI 50-pin ribbon cable connector
- #4 Speaker connector
- #5 120-pin, 32-bit, "030 Direct Slot" expansion connector

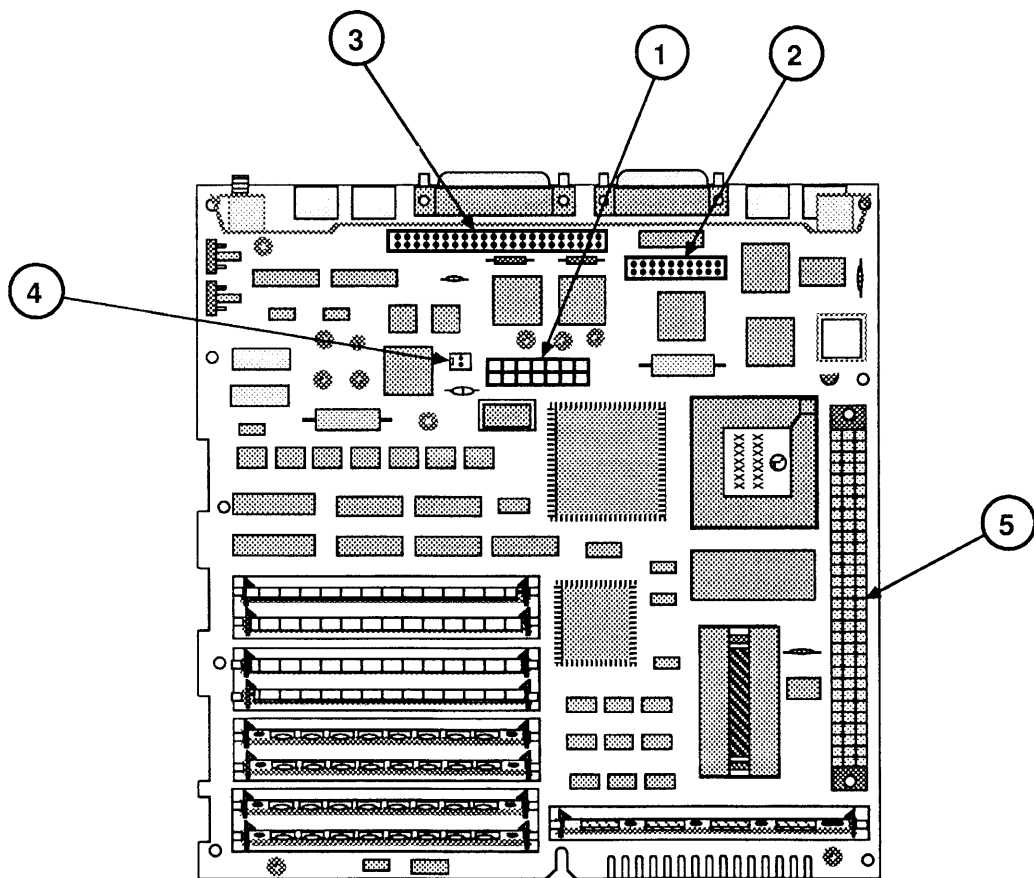

FIGURE 4

Internal Expansion Connectors

The Macintosh SE contains a 96-pin, right-angle connector for supporting Apple and third-party expansion cards. This connector has been replaced in the Macintosh SE/30 by a 120-pin connector that is vertically mounted to simplify installation.

Macintosh SE 96-pin Expansion Connector

The 96-pin Euro-DIN connector on the Macintosh SE logic board may be used in either of two ways:

- To attach a third-party coprocessor board directly to the logic board via a right-angle connector. The coprocessor board (measuring about 4 X 8 inches) would lie above and parallel to the logic board, supported by standoffs that may be installed in the logic board holes provided for that purpose.
- To attach a cable that is then routed to an external I/O device. From the connector on the logic board, the cable is routed up through the forward hole in the bottom of the metal chassis, through the mounting bracket on the rear of the chassis, and out through the snap-out accessory door on the rear of the case. (Remove the rear accessory door from inside the case.)

Note: Protruding tabs on some Macintosh SE chassis may interfere with the installation of third-party coprocessor boards, cards, or cables. If you encounter such an installation problem, perform the "Chassis Tab Modification" procedure (see Additional Procedures).

Macintosh SE/30 "030 Direct Slot" Expansion Connector

The internal expansion connector in the Macintosh SE/30, known as the "030 Direct Slot," enables Apple and third-party expansion cards to directly access the 32-bit address and data bus of the 68030 microprocessor. This new slot architecture delivers the improved performance of the 32-bit bus and has other benefits for expansion card developers. However, the greater pin demands of the 32-bit bus require using a 120-pin connector in the Macintosh SE/30. As a result, most accelerator and video expansion cards designed to utilize the 16-bit data bus in the Macintosh SE cannot be used in the Macintosh SE/30.

□ THEORY OF OPERATION

Introduction

The Macintosh SE and Macintosh SE/30 have eight basic functional units:

- Main logic board
- Power supply
- Analog board
- Internal disk drive(s)
- Internal SCSI hard disk (optional for Macintosh SE)
- Video board
- Video display (CRT)
- Apple Desktop Bus keyboard and mouse

"Module swapping," or repair by replacement of faulty modules, is much faster if you have a basic understanding of the function of each module in the unit. If you know what each module does when it is functioning normally, you can more easily decide which module is at fault when a particular function is missing or degraded. This is called "logical troubleshooting." The following section describes the Macintosh SE and Macintosh SE/30 modules and the functions they perform.

Main Logic Board

The main logic boards of the Macintosh SE and Macintosh SE/30 contain the components described below. Components unique to one system or the other are identified as such.

CPU

Macintosh SE: The Central Processing Unit (CPU) in the Macintosh SE is a Motorola 68000 microprocessor. The microprocessor gets instructions from memory, translates them, and carries them out. It communicates with all components on the logic board, and with all peripherals.

Macintosh SE/30: At the heart of the Macintosh SE/30 is the Motorola 68030 microprocessor with a 32-bit external address and data bus. This high-performance microprocessor operates at 16 MHz—double the clock speed of the 68000. The 68030 microprocessor also supports paged memory management, thereby eliminating the need for a separate PMMU chip. Paged memory management is a type of parallel processing that enables the computer to swap *pages* of data from a disk into RAM memory, as needed, which makes the Macintosh SE/30 appear to have more memory than it actually has.

The Macintosh SE/30 logic board also includes the 68882 math coprocessor composed of IEEE P754 standard floating-point ICs. The 68882 provides a high degree of precision and speed for Macintosh programs.

RAM

Macintosh SE: Macintosh SE RAM (Random-Access Memory) is installed on 150-nanosecond Single In-line Memory Modules (SIMMs). Each SIMM is a small printed circuit card with mounted ICs. The logic board has four sockets for SIMMs. The Macintosh SE comes with four 256K SIMMs installed for 1 MB of RAM, or with two 1-MB SIMMs installed for 2 MB of RAM.

Macintosh SE/30: The Macintosh SE/30 has two banks of four SIMM sockets, and comes with 1 MB or 4 MB of RAM. The amount of RAM on the logic board can be changed by installing SIMMs of higher memory capacity. Each bank must be filled with four SIMMs of the same size, and Bank A (the first four rows closest to the edge of the board) must be filled first, or filled with the SIMMs of higher capacity. Both 256K and 1 MB SIMMs are currently available, allowing 1 MB, 2 MB, 4 MB, 5 MB, or 8 MB configurations. The Macintosh SE/30 can use only 120-nanosecond SIMMs.

Every time the Macintosh SE or Macintosh SE/30 is powered on, the system performs a memory test to determine how much RAM is present in the machine.

ROM

Macintosh SE: The two ROM (Read-Only Memory) chips in the Macintosh SE contain the operating code for the 68000. The Macintosh SE ROM supports the Apple Desktop Bus, SCSI devices, AppleTalk networks, and (since August, 1989) the FDHD disk drive. The ROM chips at positions D6 and D7 on the logic board are socketed. These ROMs should be replaced only when installing the FDHD Upgrade Kit.

Macintosh SE/30: The four custom chips making up system ROM for the Macintosh SE/30 are mounted on a single SIMM module. This design facilitates feature set upgrades, and allows the technician to easily install upgraded or customized ROM. Included in the 256K of permanent ROM memory for the Macintosh SE/30 are routines for supporting the FDHD disk drive and SWIM disk controller, NuBus slot manager, and Apple sound manager.

*Disk
Controller
Chip*

Macintosh SE: Macintosh SEs sold *after* August 1989, or Macintosh SEs upgraded to run the 1.4 MB FDHD disk drive, use the SWIM disk controller chip (see the description under "Macintosh SE/30" below). Macintosh SEs sold *before* August 1989 use the IWM chip, a self-contained disk controller on one IC that supports all Apple format (GCR, for Group Code Recording), 3.5-inch internal and external disk drives. The IWM simplifies the microprocessor's task of reading from and writing to the disk drives. The IWM, located at position D8 on the logic board, is socketed and may be replaced by the technician.

Macintosh SE/30: The Macintosh SE/30 and all current versions of the Macintosh SE use a SWIM disk controller chip. The SWIM chip incorporates the functionality of the IWM, and also enables the FDHD disk drive to exchange data between Apple and MS-DOS systems. The SWIM chip interprets, converts, and outputs dual disk (clock/time) and file (data) signals as appropriate for either GCR (variable rotational speed) or MFM (constant rotational speed) formats. The SWIM chip enables the FDHD drive to read, write, and format in both GCR (Apple 400K and 800K) and MFM (MS-DOS 720K and 1.4 MB; and Apple 1.4 MB) data formats.

*Serial
Communications
Controller*

The Serial Communications Controller (SCC) handles information sent to and received from the serial ports on the back of the machine.

*Versatile
Interface
Adaptor*

The Versatile Interface Adaptor (VIA) converts serial data (from input devices) to parallel data, so that the logic board can interpret the information correctly.

Gate Array

The Macintosh SE and Macintosh SE/30 incorporate the gate array implementation of PAL (Programmable Array Logic) and other discrete logic devices. The gate array handles control and synchronizing functions for the main logic board.

Oscillator

The oscillator, or timing device, generates the master clock pulse, which is broken down into the various timing signals needed by the ICs on the logic board.

Battery

The Macintosh SE and Macintosh SE/30 are equipped with a single long-life lithium battery that provides power to the system clock and calendar. This battery is installed in a battery holder and can be replaced without cutting and soldering. In earlier versions of the Macintosh SE, the battery is soldered to the logic board.

Sound Chip

The sound chip supports the internal speaker connector and the external sound jack. The Macintosh SE/30 logic board contains a new, full-stereo sound chip.

SCSI Bus

The Apple SCSI manager supports up to seven daisy-chained SCSI devices.

Apple Desktop Bus

The Apple Desktop Bus is a method and protocol for connecting computers with human input devices. The Macintosh SE and Macintosh SE/30 control the flow of data to connected devices by issuing commands through the Apple Desktop Bus.

Power Supply

The power supply is attached to the bottom half of the analog board. This is where AC voltage is converted to DC voltage for use by the entire system. The power supply operates on standard line voltage and outputs various DC voltages, which are used by the logic board, the video display, and by some peripheral devices.

Analog Board

The analog board contains circuits for both horizontal and vertical signals that are fed to the CRT. The flyback transformer on the analog board delivers high voltage directly to the CRT through the anode connector.

CRT and Video Board

The Cathode-Ray Tube (CRT) provides the high-resolution video display. The anode of the CRT receives high voltage from the flyback transformer on the analog board. The analog board also supplies the voltages and signals to the neck and yoke of the CRT that enable the CRT to create the video display. There is a separate video board on the neck of the CRT that provides video amplification and overvoltage protection.

Disk Drive(s)

The internal disk drive (or drives) used in the Macintosh SE and Macintosh SE/30 connect to the main logic board through two internally installed connectors. An external disk drive may be connected to the disk drive port on the back of the logic board. The flow of data between the logic board and the disk drives is channeled through a disk controller chip, which controls reading and writing operations.

The internal disk drive in the Macintosh SE and Macintosh SE/30 is the high-density, 1.4 MB FDHD (Floppy Drive High Density) disk drive. The FDHD drive reads/writes and formats both GCR and MFM format disks, thereby providing data exchangeability between MS-DOS, ProDOS, and Macintosh systems. An application-specific translator within the Apple File Exchange utility program must be used to translate the exchanged data for use within an application program.

SCSI Hard Disk

The SCSI hard disk (optional on the Macintosh SE) connects to the logic board through the internal SCSI connector. Other SCSI devices may be daisy-chained to the Macintosh SE and Macintosh SE/30 through the external SCSI port. The SCSI bus on the logic board will support a total of seven SCSI devices.

Apple Desktop Bus Keyboard and Mouse

The keyboard connects to the Apple Desktop Bus (ADB) port on the Macintosh SE and Macintosh SE/30. The mouse connects to the keyboard or to the computer's other ADB port. All devices made for the Apple Desktop Bus have a microprocessor that makes them intelligent devices. All Apple Desktop Bus devices communicate with the logic board via a mini DIN-4 connector. All except the mouse have ports for daisy-chaining other ADB devices. The mouse must be the last device in the chain because it has no port.

□ CARE AND HANDLING

The Macintosh SE and Macintosh SE/30 are small enough to be somewhat portable. However, the computers contain a CRT (cathode-ray tube—the picture tube), which operates at very high voltages and contains a high vacuum. If cracked or broken, the CRT can implode (collapse into itself), then explode.

WARNING: Before working inside this computer, read Section 8, CRT Safety, under the You Oughta Know tab.

Both computers may also contain hard disks (a hard disk drive comes standard with the Macintosh SE/30, and is optional for the Macintosh SE). The hard disk is a mechanical device with moving parts. Rough handling such as jarring or bumping, especially while the hard disk is running, could result in a mechanical failure or damage to the information stored on the hard disk.

Careless handling accounts for more drive failures than all other factors combined.

With these facts in mind, always be sure to:

- Leave the Macintosh SE and Macintosh SE/30, and the CRT and hard disk drive modules, in shipping containers until use.
- Use the shipping containers and packing materials when transporting the computer or modules.
- Place the computer on a protective padded surface before beginning any repair procedure.
- Never move a computer with a hard disk drive during power-down. After the power is turned off, the hard disk will slow down and the heads will land within 15 seconds. Any jolts to the drive during power-down may cause the heads to crash into the media surfaces.
- Never drop a Macintosh SE or Macintosh SE/30. Even a drop of one inch to a hard surface could cause implosion of the CRT and/or a hard disk drive failure.

Macintosh SE and Macintosh SE/30

Section 2 – Take-Apart

□ CONTENTS

- 2.2 Cover
- 2.5 Discharging the Cathode-Ray Tube (CRT)
 - 2.5 Discharge Procedure
- 2.7 Anode Cap
- 2.8 Analog Board and Power Supply
- 2.14 Main Logic Board
 - 2.16 Identifying Macintosh SE Logic Boards
- 2.22 SIMMs
- 2.25 Video Board
- 2.28 Cathode-Ray Tube (CRT)
- 2.31 Internal SCSI Hard Disk Drive
 - 2.31 Identifying 20SC Revision A and B Drives
 - 2.33 Removing the Drive From Its Carrier
 - 2.33 Replacing the Drive In Its Carrier
- 2.35 LED Cable Assembly
- 2.37 Upper Internal Disk Drive
- 2.40 Lower Internal Disk Drive
- 2.42 Fan Assembly
- 2.46 Speaker, Front Bezel, and Slot Cover

Note: If a step is underlined, detailed instructions for that step can be found elsewhere in this section.

□ COVER

WARNING: *Macintosh SE and SE/30 computers contain high voltage and a high-vacuum picture tube. To prevent serious personal injury and property damage, be sure you read and understand the safety precautions in Section 8, CRT Safety, under the You Oughta Know tab before you remove the back cover. Failure to follow the safety rules could result in serious injury.*

CAUTION: *Electrostatic Discharge (ESD) can cause severe damage to sensitive microcircuits. The Macintosh SE and Macintosh SE/30 logic boards contain C-MOS components, among the most sensitive chips in use today. Printed circuit assemblies and ICs (integrated circuits, or "chips"), especially those that are removable, must also be handled with extreme care. The Macintosh SE and Macintosh SE/30 also have removable ROMs, ROM SIMMs, and RAM SIMMs, which contain the RAM memory. The C-MOS chips, ROMs, and SIMMs are very susceptible to ESD damage. To prevent ESD damage to these components, follow the precautions outlined for ESD prevention in You Oughta Know.*

Materials Required

Foam pad
Small flat-blade screwdriver
15-inch Torx screwdriver
Pull-apart tool

Remove

Remove the cover as follows:

1. Place the Macintosh SE or Macintosh SE/30 on the foam pad in an area where you will have ample room to remove the cover. Don't put it under shelves containing objects that could fall on the CRT and break it.

Note: Be especially careful when handling a Macintosh SE/30, or a Macintosh SE with an internal hard disk. Read "Care and Handling" in the Basics section before continuing.

2. Turn off the power and disconnect the power cord.
3. Disconnect the keyboard and mouse cables and all other peripheral cables from the back of the Macintosh SE or Macintosh SE/30.

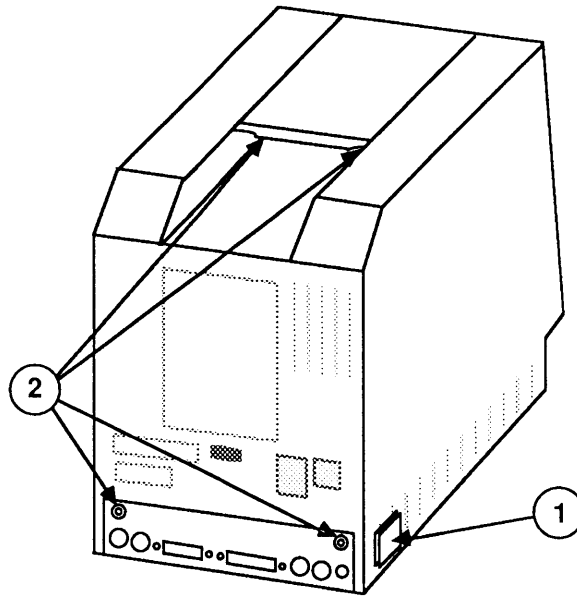

FIGURE 1

4. If a reset/interrupt switch (Figure 1, #1) is present, pry it off with a small flat-blade screwdriver.
5. Place the Macintosh SE or Macintosh SE/30 face-down on the pad.
6. Use the Torx screwdriver to remove the four case screws (Figure 1, #2).
7. Carefully lift up the cover and set it out of the way. If the cover is difficult to remove, use the pull-apart tool. (To prevent cosmetic damage to the cover and bezel, do not use a screwdriver to pry off the cover.)
8. Remove the insulating paper shroud from the bottom of the Macintosh SE or Macintosh SE/30.

Replace

Replace the cover as follows:

WARNING: *The edges of the metal chassis may be sharp. When moving the computer with the cover removed, be sure to handle the metal chassis carefully.*

1. Place the computer face-down on the foam pad.
2. Replace the insulating paper shroud over the bottom of the Macintosh SE or Macintosh SE/30.

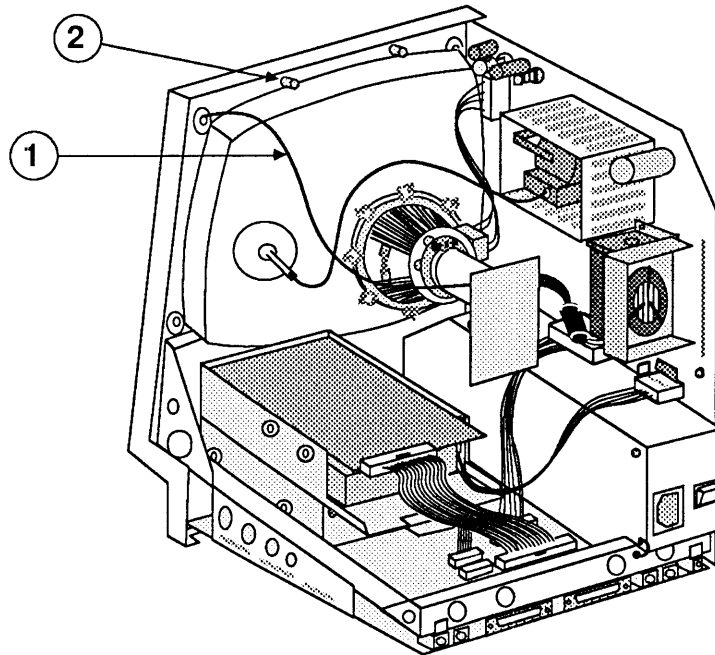

FIGURE 2

3. Slide the cover over the chassis and fit it into the front bezel, making sure the video ground cable (Figure 2, #1) is out of the way of the case screw holder (Figure 2, #2).

4. Reinstall the four case screws (Figure 3, #2).

Note: The two black screws should be installed in the bottom of the case and the two silver screws in the top.

5. Reinstall the reset/interrupt switch (Figure 3, #1).

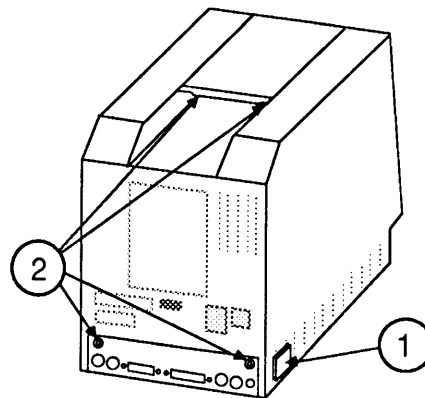

FIGURE 3

□ DISCHARGING THE CATHODE-RAY TUBE (CRT)

The CRT in the Macintosh SE and Macintosh SE/30 is equipped with a bleeder resistor that automatically drains the charge from the CRT when the power is shut off. **Nevertheless, you must follow the discharge procedure below to protect yourself in the event that the resistor has failed and the anode is still charged.**

Materials Required

Safety goggles
Foam pad (ungrounded)
Needlenose pliers
Alligator lead
New CRT discharge tool (part number 076-0381)

WARNING: Before starting, read the safety precautions and the CRT discharge procedure in Section 8, CRT Safety, under the You Oughta Know tab. Alternative instructions for discharging the CRT using the older version of the discharge tool (and/or a screwdriver) are also given in that section.

Discharge Procedure

1. **Remove your grounding wriststrap and jewelry and put on safety goggles before beginning!**

WARNING: Do not touch the yoke wires (Figure 4, #1), the anode wire (Figure 4, #2), the anode connector (Figure 4, #3), or the flyback transformer (Figure 4, #4).

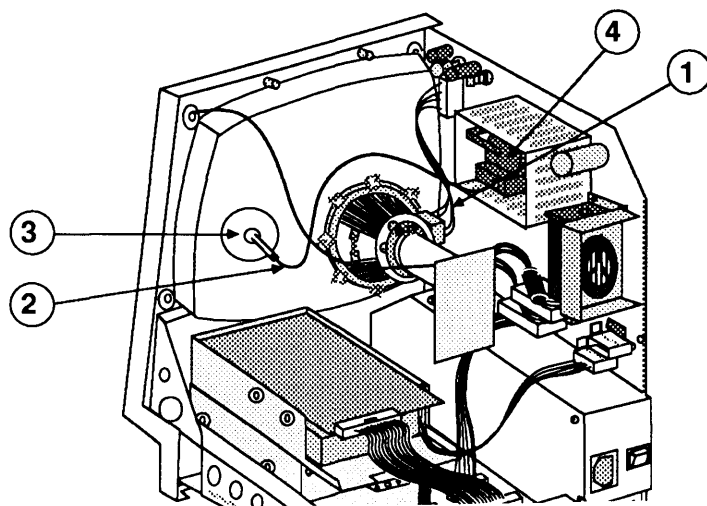

FIGURE 4

2. Remove the cover.
3. Set the monitor upright on the ungrounded foam pad, with the back of the monitor facing you.

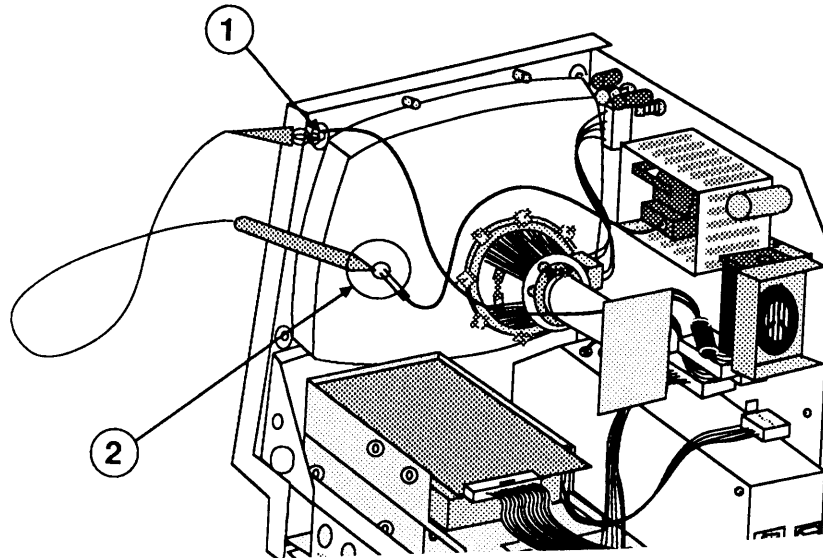

FIGURE 5

4. Attach the alligator clip on the CRT discharge tool to the metal part of the **ground lug** (Figure 5, #1).

CAUTION: Discharge the anode to the metal part of the ground lug displayed in Figure 5, #1. **Failure to do so will damage the main logic board and/or the analog board.**

5. Put one hand behind your back and grasp the handle of the discharge tool with your other hand.

WARNING: Use only one hand when discharging the CRT. This is to prevent you from becoming a path for current should your hand slip and touch the metal part of the discharge tool. While discharging the CRT, grasp only the insulated handle of the discharge tool.

6. Hold the CRT discharge tool to the tube surface, and insert it under the anode cap (Figure 5, #2) until it touches the anode ring.

7. Remove the CRT discharge tool from under the anode cap. Remove the alligator clip from the ground lug. Set the tool aside where it will be out of the way.

Note: If the bleeder resistor fails, a secondary charge can build up over time, even after you have discharged the CRT. If repairs are not finished within 30 minutes, the anode should be discharged again. Or, to ensure that any residual charge is dissipated during the service procedure, establish a path for anode current to ground by fastening one end of an alligator lead to the metal ground lug and connecting the other end to the anode ring.

Anode Cap

For some of the following procedures, you may have to remove the anode cap. To do so, peel back the anode cap until you can see the anode ring at the center. Look at the metal connector in the center of the cap and notice how it is clipped into the CRT. Use the needlenose pliers to compress the two prongs on the clip to free it from the CRT, and lift it off the tube.

□ ANALOG BOARD AND POWER SUPPLY

Materials Required

Grounded workbench pad and wriststrap
Small Phillips screwdriver

Remove

To remove the analog board and power supply:

1. Remove the cover and discharge the CRT.
2. Remove the anode cap (Figure 6, #1).

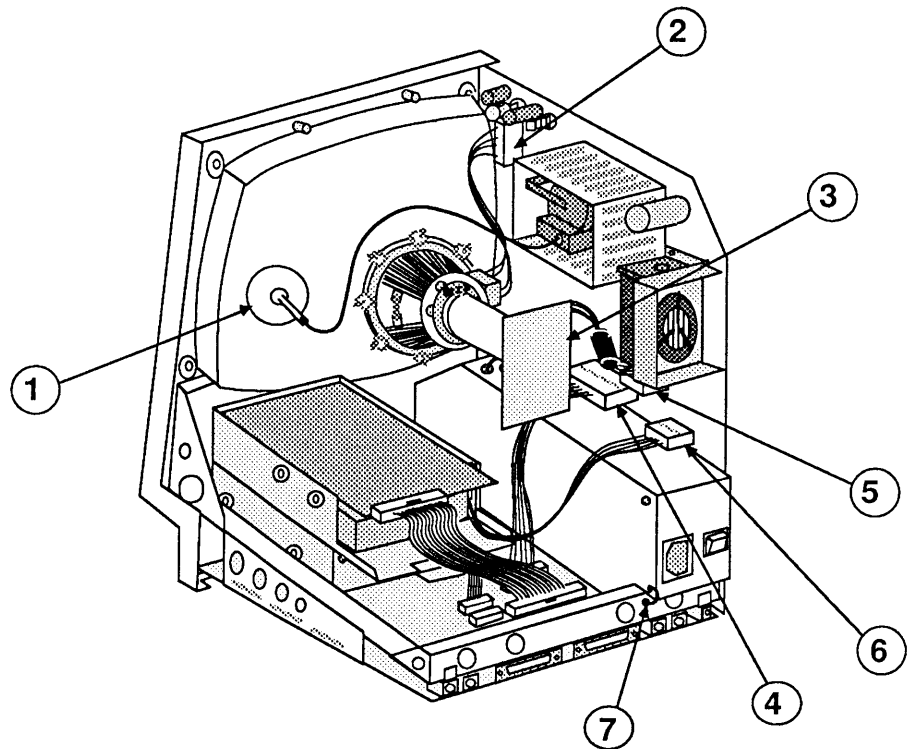

FIGURE 6

3. Move the Macintosh SE or Macintosh SE/30 onto a soft, grounded workbench pad and put on your grounding wriststrap. (Never do this until after the CRT is discharged.)
4. Carefully pull the video board (Figure 6, #3) off the neck of the CRT.

5. Remove the following cables from the analog board:
 - Yoke cable (Figure 6, #2) (First depress the tab.)
 - Main logic board cable (Figure 6, #4)
 - Video board cable (Figure 6, #5)
 - Hard disk power cable, if present (Figure 6, #6)
6. Remove the screw holding the power supply ground wire to the chassis (Figure 6, #7).

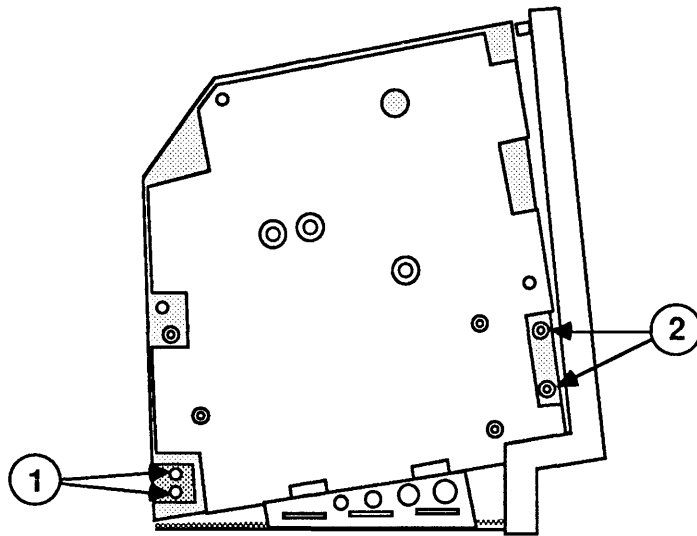

FIGURE 7

7. Using the small Phillips screwdriver, remove the two lower left analog board screws and the metal clip (Figure 7, #1).
8. Remove the two lower right analog board screws (Figure 7, #2).
9. Place the Macintosh SE or Macintosh SE/30 face down on the grounded workbench pad.

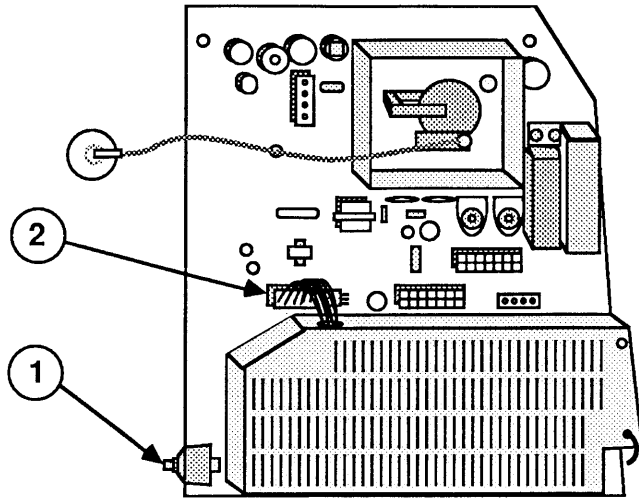

FIGURE 8

10. Carefully move the analog board (with power supply attached) up and away from the chassis, taking care not to bump the CRT or the brightness control knob (Figure 8, #1) at the lower front of the analog board.

WARNING: Do not grasp the analog board by the fan. Hold the analog board by the edges, using your fingertips.

11. Disconnect the power supply cable (Figure 8, #2) from the analog board.

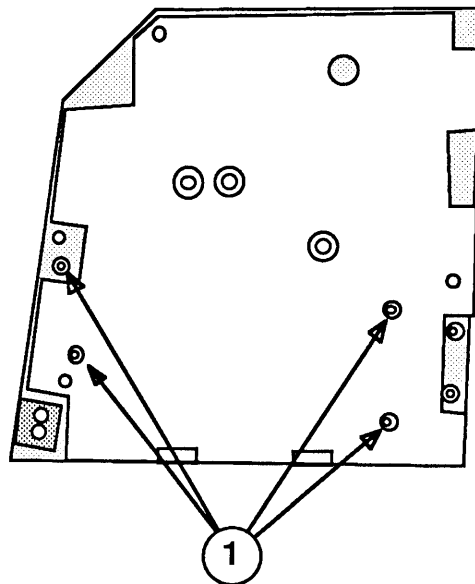

FIGURE 9

12. Place the board on the grounded workbench pad with the power supply down, and remove the four power supply screws (Figure 9, #1). Lift the board free.

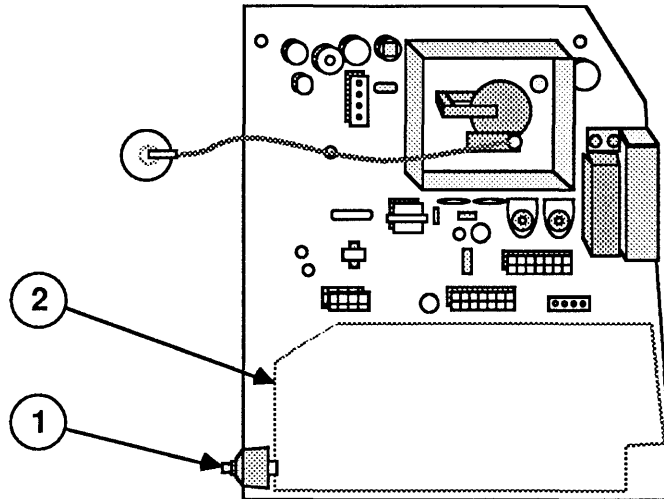

FIGURE 10

13. If you are returning the analog board to Apple, first remove the brightness knob (Figure 10, #1) and put the knob on the replacement analog board.

Replace

Follow the steps below to replace the power supply and analog board. Also, **if you are installing a new analog board on a Macintosh SE, and a clip-on ferrite bead is packaged with the new analog board**, you may have to install the ferrite bead on the video board cable. Check your video board; if a ferrite bead is not on the cable, install the clip-on ferrite bead enclosed with the new analog board on the video board cable (see the Video Board procedure).

1. Place the power supply on the inside of the analog board, using the painted outline on the board as a guide (Figure 10, #2).
2. Holding the power supply in position, flip the analog board and power supply to a face-down position with the power supply underneath. **Do not grasp the analog board by the fan.**
3. Replace the four power supply screws (Figure 9, #1).

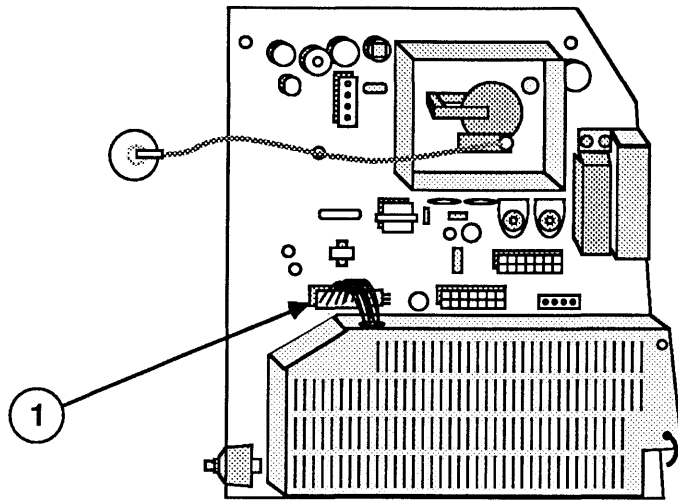

FIGURE 11

4. Reconnect the power supply cable (Figure 11, #1).
5. With the Macintosh SE or Macintosh SE/30 face down on the grounded workbench pad, carefully place the analog board/power supply unit in the chassis, taking care not to bump the CRT or the brightness knob at the lower front of the analog board. It is easiest if you slide the corner with the brightness knob in first, then maneuver the power supply cage past the metal bracket at the back of the chassis. **Again, do not grasp the analog board by the fan.**
6. Replace the metal clip and the two lower-left analog board screws (Figure 12, #1).

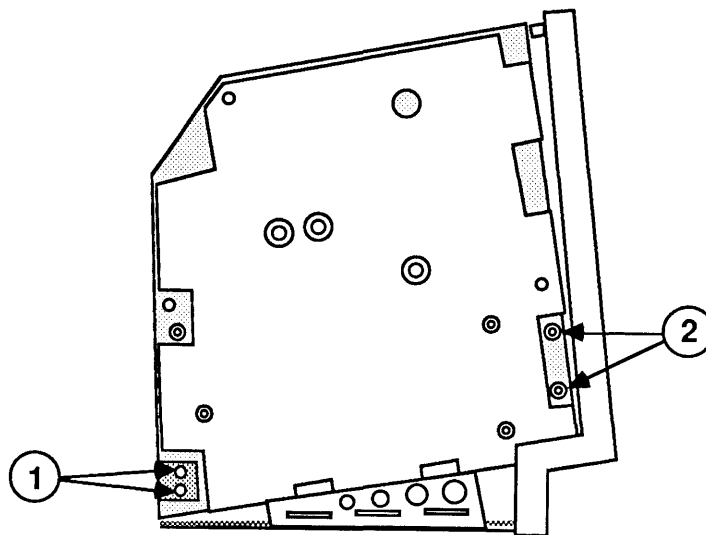

FIGURE 12

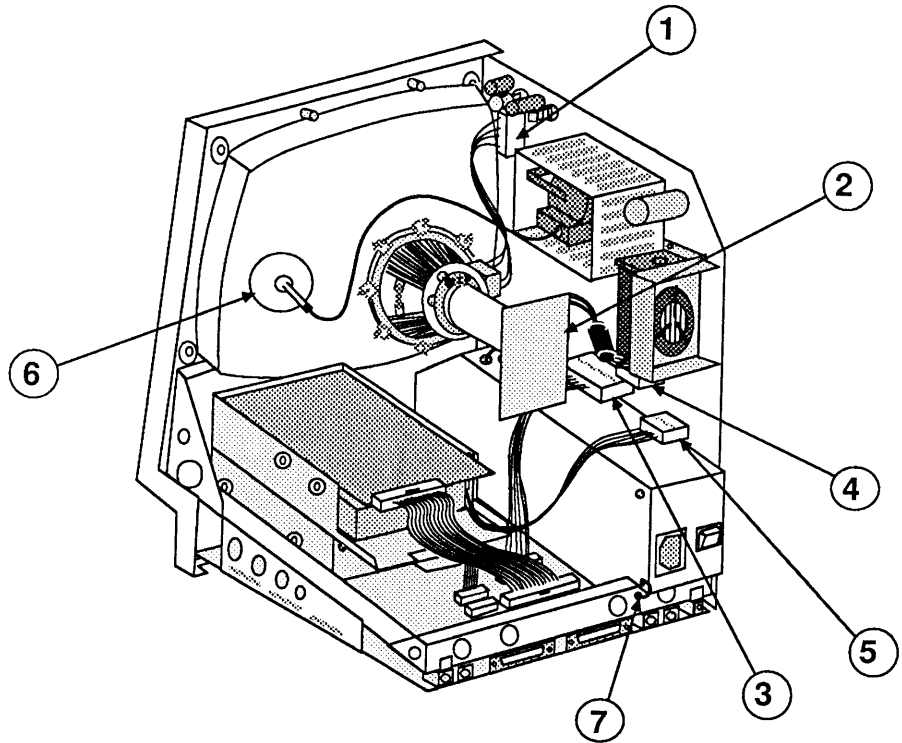

FIGURE 13

7. Replace the two lower-right analog board screws (Figure 12, #2).
8. Reconnect the following cables to the analog board:
 - Yoke cable (Figure 13, #1)
 - Main logic board cable (Figure 13, #3)
 - Video board cable (Figure 13, #4)
 - Hard disk drive power cable (Figure 13, #5), if present
9. Replace the anode cap (Figure 13, #6).
10. Reconnect the video board (Figure 13, #2) to the neck of the CRT. It fits only one way.
11. Replace the screw that secures the power supply ground wire to the chassis (Figure 13, #7).
12. Replace the cover.

□ MAIN LOGIC BOARD

Materials Required

Grounded workbench pad and wriststrap
Small Phillips screwdriver
IC extractor

Remove

Follow these steps to remove the main logic board:

1. Remove the cover.
2. Discharge the CRT.
3. Put on your grounding wriststrap. (Never do this until after the CRT has been discharged.)

CAUTION: *In the following step, pull only on the pulltabs or on the connectors themselves, **not** on the cables.*

4. Carefully pull the video board (Figure 14, #4) off the neck of the CRT.

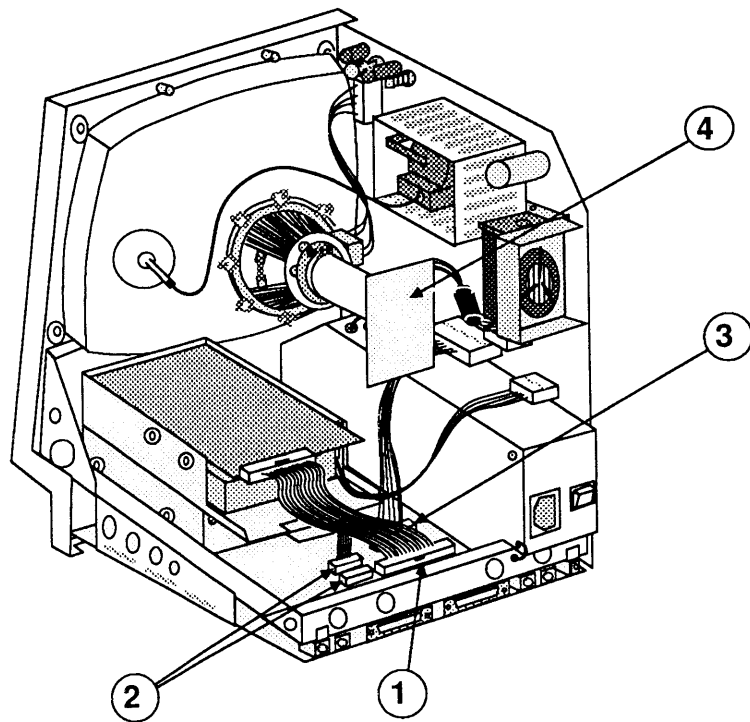

FIGURE 14

5. Remove these connectors from the main logic board:
 - Hard disk drive cable, if present (Figure 14, #1)
 - Internal disk drive cable(s) (Figure 14, #2)
 - Power supply cable (Figure 14, #3) (You must depress the holding clip on this connector before you can pull it out.)
6. Place the Macintosh SE or Macintosh SE/30 face down on a grounded workbench pad, with the bottom of the main logic board facing you. You will see that the right edge of the board is notched and the left edge is smooth.

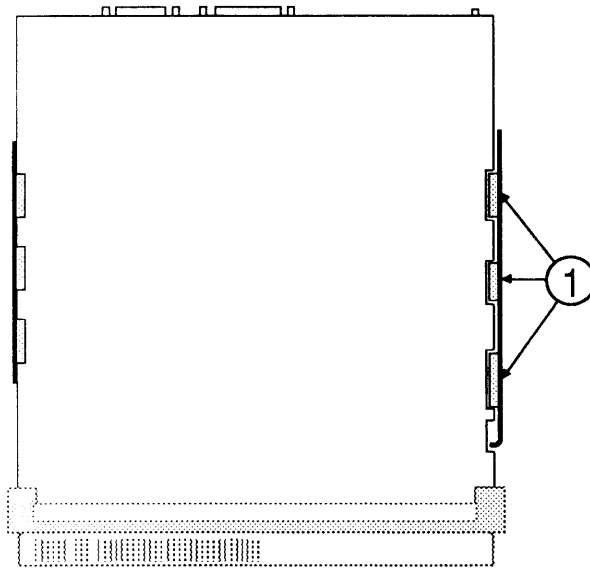

FIGURE 15

7. Holding the board by the edges, slide it up until the tabs on the right edge of the board exactly match the notches in the right metal bracket (Figure 15, #1).
8. Swing the right edge of the board free of the metal bracket and lift the board out of the metal chassis.

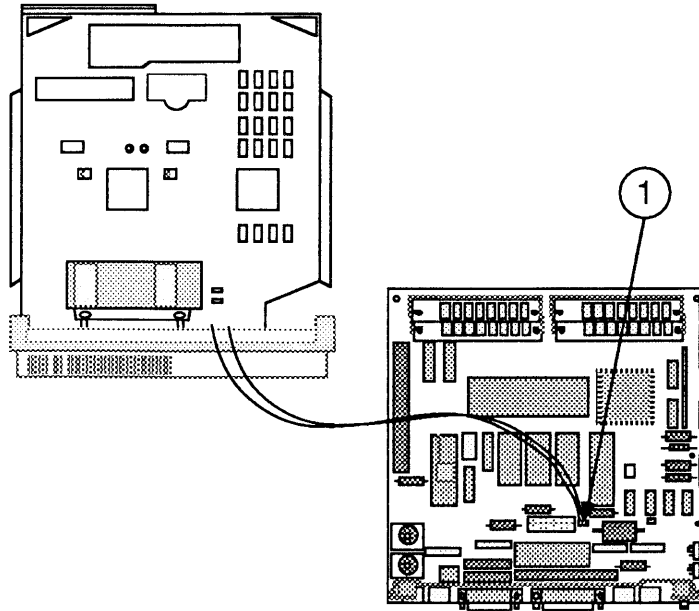

FIGURE 16

9. With the main logic board held upright beside the computer, disconnect the speaker cable (Figure 16, #1). Place the board on the grounded workbench pad.

Identifying Macintosh SE Logic Boards

Two logic boards are available as exchange modules for the Macintosh SE. If you are replacing the logic board of a Macintosh SE that was originally shipped with an FDHD drive, use logic board 661-0536. If your customer's computer was originally shipped with an 800K internal drive, or has been **upgraded** to use an FDHD drive, use replacement logic board 661-0526.

Be sure to use an exchange logic board that is configured the same as the customer's original board. Use the following procedure to identify the correct exchange module:

1. Identify the customer's battery configuration (Figure 17, #1):
 - a) If the battery is installed in a battery holder (Figure 17, #2), use replacement logic board 661-0536 and go directly to the steps for replacing the logic board (see "Replace").
 - b) If the battery is soldered to the logic board (Figure 17, #3), perform step 2 next.

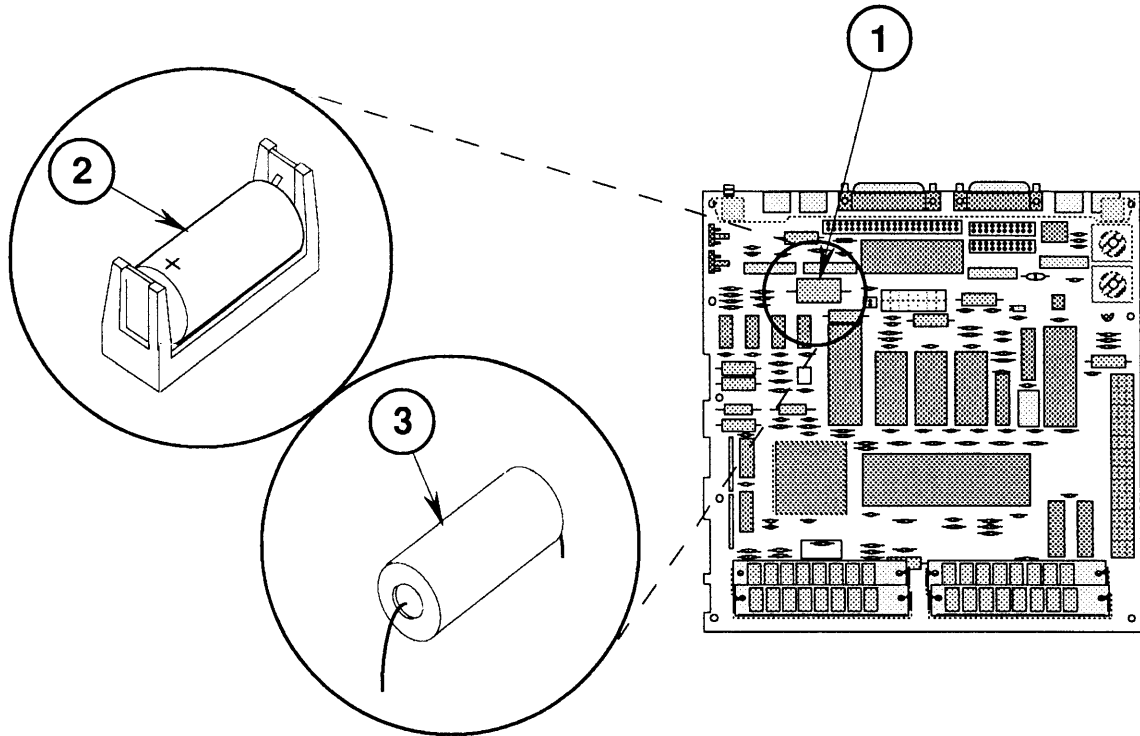

FIGURE 17

2. Identify the customer's disk controller chip (Figure 18, #1):
 - a) If the part number on the disk controller chip is 344-0062 (SWIM chip), use replacement logic board 661-0526 and perform step 3 next.
 - b) If the part number on the disk controller chip **is not** 344-0062, use replacement logic board 661-0526 and go directly to the steps for replacing the logic board (see "Replace").

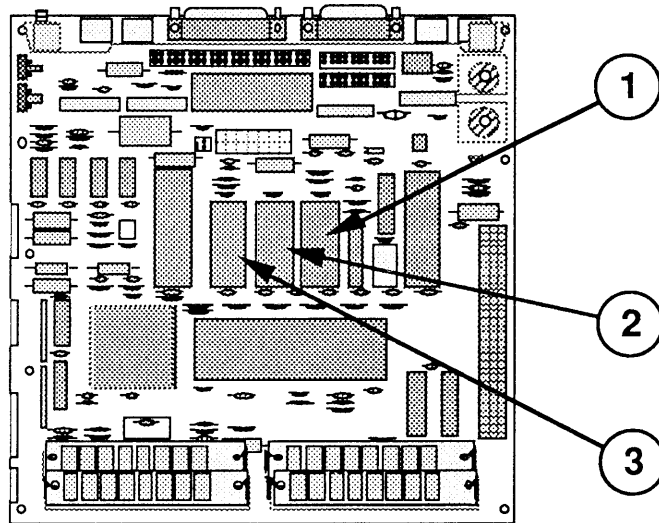

FIGURE 18

IMPORTANT: Failure to transfer the customer's SWIM chip and upgraded ROMs to the replacement logic board will prevent an FDHD drive from utilizing high-density media.

3. Using the IC extractor, remove the following chips from the customer's logic board and install them in the same positions on the replacement logic board. (The notched end of the chips should face the front of the logic board. For more information see "1.4 MB Apple FDHD Upgrade for the Macintosh SE" in Section 5, Additional Procedures.)
 - SWIM (Figure 18, #1)
 - Low ROM (Figure 18, #2)
 - Hi ROM (Figure 18, #3)

Return the ROMs and IWM chip to Apple on the customer's faulty logic board.

Replace

1. Position the main logic board at the rear of the Macintosh SE or Macintosh SE/30. The tabbed edge of the board should be on the right.
2. Reconnect the speaker cable (Figure 19, #1) to the main logic board.

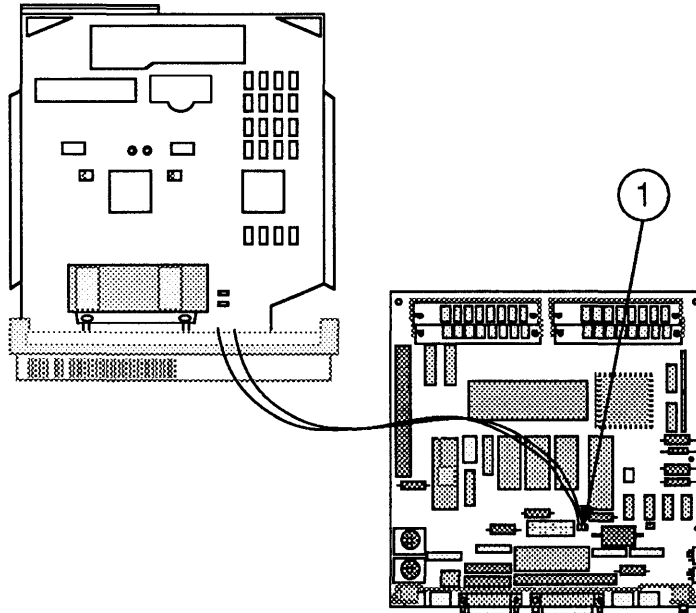

FIGURE 19

3. Fit the smooth left edge of the main logic board into the slot in the metal frame.

- Exactly align the tabs on the right edge of the board with the notches on the right metal bracket (Figure 20, #1), and settle the right edge of the board into the right metal bracket. Slide the board down until you hear it click into place.

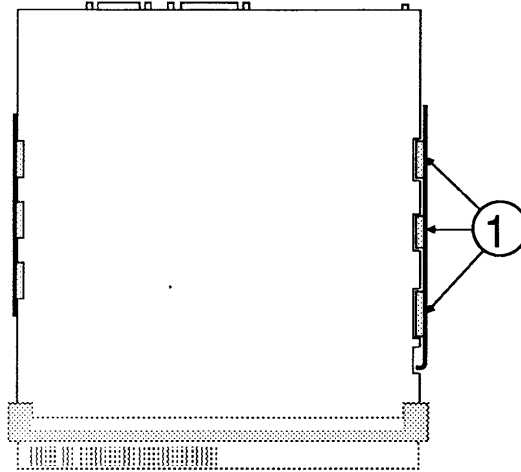

FIGURE 20

- Place the Macintosh SE or Macintosh SE/30 upright, so that you can see the inside of the chassis.

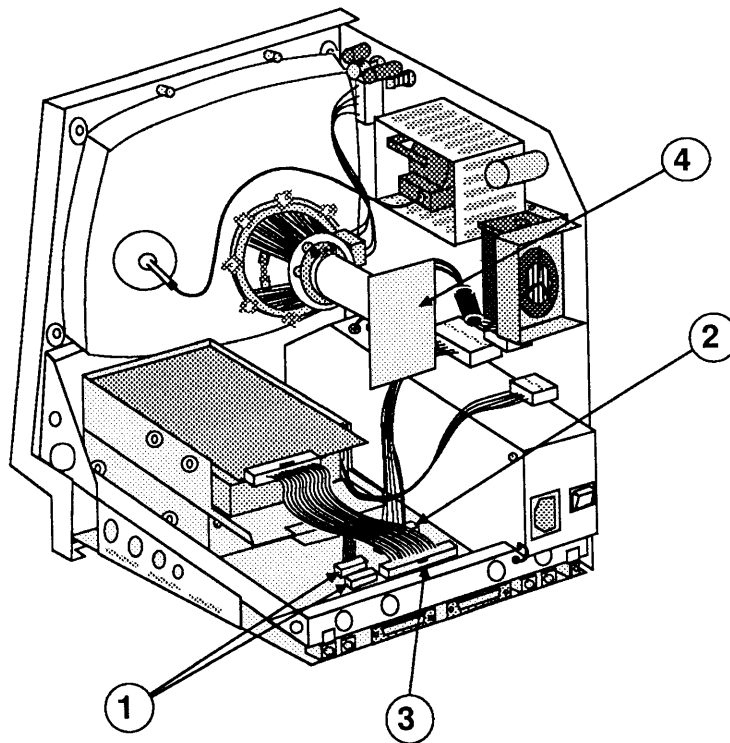

FIGURE 21

6. Reconnect the following to the main logic board:
 - Internal disk drive cable(s) (Figure 21, #1)
 - Power supply cable (Figure 21, #2)
 - Hard disk drive cable, if present (Figure 21, #3)
7. Reconnect the video board (Figure 21, #4) to the neck of the CRT. It fits only one way.
8. Replace the cover.

Note: If the diagnostics indicates that the replacement logic board is bad, **and the original board had been upgraded for the FDHD drive**, you may have swapped bad ROM or SWIM chips. Run AppleCAT and observe the test results displayed on the Status line. If any ROM or SWIM chips are faulty, replace the bad chips and reinstall the customer's original logic board.

□ SIMMs

Macintosh SE: The Macintosh SE logic board has four SIMM sockets, as shown in **Figure 22**. It comes with 1 megabyte of RAM installed on four 256K Single In-line Memory Modules (SIMMs), or with 2 megabytes of RAM installed on two 1 MB SIMMs. The original 256K and 1 MB SIMMs for the Macintosh SE are 150 nanosecond; replacement SIMMs are 120 nanosecond. (The 120- and 150-nanosecond SIMMs are interchangeable in the Macintosh SE.)

Macintosh SE/30: The Macintosh SE/30 logic board has two banks of four SIMM sockets, as shown in **Figure 23**. It comes in a 1-megabyte configuration that has four 256K SIMMs installed in bank A, or in a 4-megabyte configuration with four 1 MB SIMMs installed in bank A. All Macintosh SE/30 SIMMs are 120 nanosecond.

Note: Refer to Section 7, Additional Procedures, for procedures specifically addressing memory upgrades.

Materials Required

Grounded workbench pad and wriststrap

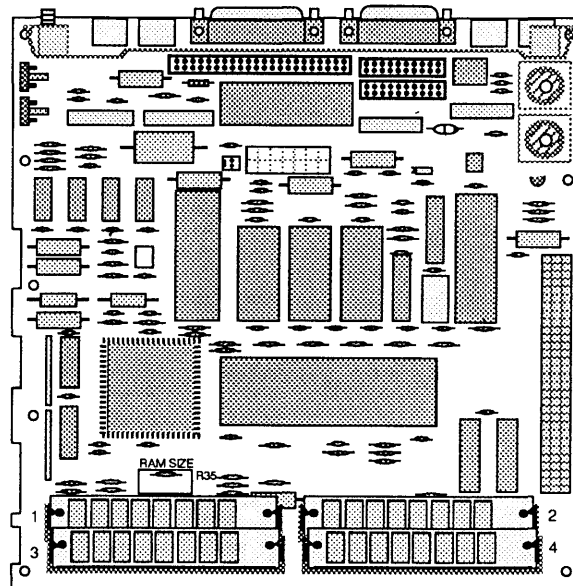

FIGURE 22

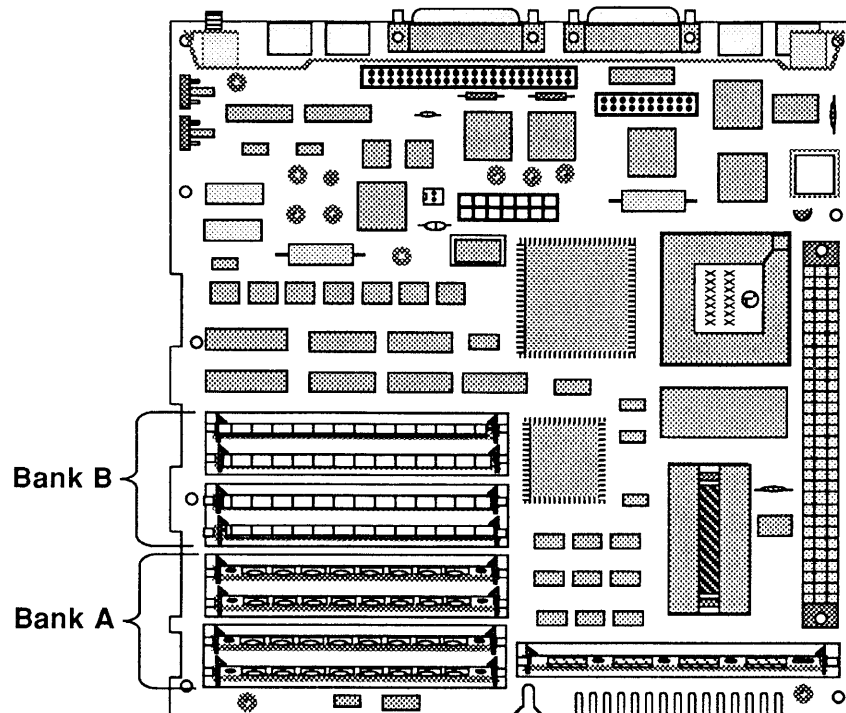

FIGURE 23

Remove

Follow the steps below to remove a SIMM from the main logic board:

1. Remove the cover and discharge the CRT.
2. Put on your grounding wriststrap and place the Macintosh SE or Macintosh SE/30 on the grounded workbench pad. (Never put on the grounding wriststrap until after the CRT has been discharged.)
3. Remove the main logic board.
4. To remove a SIMM, use the SIMM removal tool. See *You Oughta Know* for instruction on tool usage.

CAUTION: *SIMMs are very susceptible to ESD and skin acid damage. Handle only by the edges.*

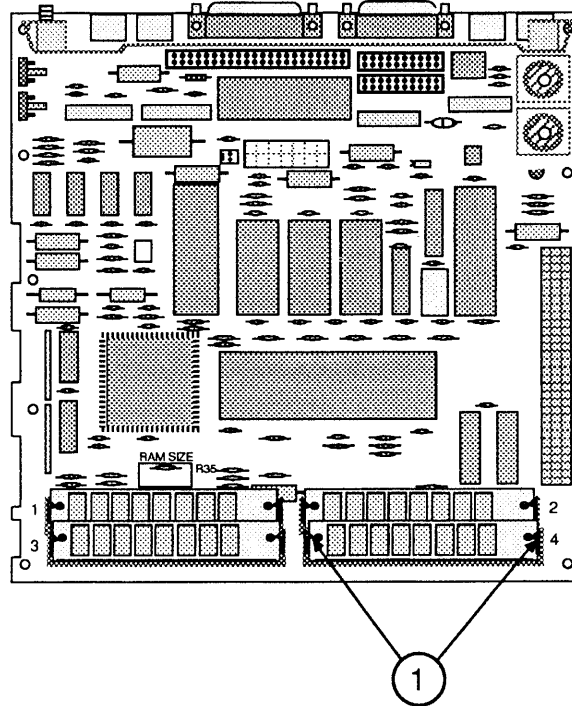

FIGURE 24

Replace

Follow the steps below to replace a SIMM:

1. With the contacts (Figure 24, #1) on the SIMM pointing down, insert the module into the connector at an angle (bottom forward).
2. Push back on the top corners of the module. You will hear a click when the module snaps into place.
3. Replace the main logic board and the cover.

□ VIDEO BOARD

Materials Required

Grounded workbench pad and wriststrap
Torx screwdriver

Remove

Follow the steps below to remove the video board:

1. Remove the cover.
2. Discharge the CRT.

WARNING: *Leave your safety goggles on for the remainder of this procedure.*

3. Put on your grounding wriststrap and place the Macintosh SE or Macintosh SE/30 on the grounded workbench pad. (Never put on the grounding wriststrap until after the CRT has been discharged.)

CAUTION: *Whenever working on the upper part of the chassis, always pull the video board off the neck of the CRT or remove it totally. This will help avoid damage to the CRT.*

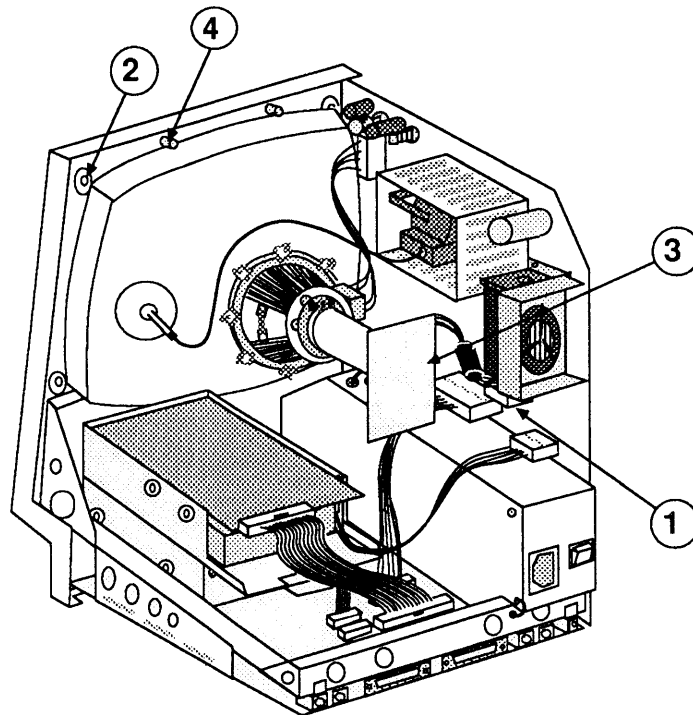

FIGURE 25

4. Carefully pull the video board (Figure 25, #3) off the neck of the CRT.
5. Disconnect the video board connector (Figure 25, #1) from the analog board.
6. Remove the Torx screw holding the video ground wire to the upper-left CRT mounting bracket (Figure 25, #2).

Replace

CAUTION: *The redesigned, vertically mounted video board must be installed with the new axial fan. The new axial fan will not allow for adequate vibration clearance when installed with the old, horizontally mounted video board.*

New video boards come with an attached ferrite bead (Figure 26, #1) to reduce interference. If your video board does not have a ferrite bead attached to the cable, **and you are installing a new analog board that is packaged with a clip-on ferrite bead**, install the ferrite bead on the video board cable as shown in steps 1 and 2 below.

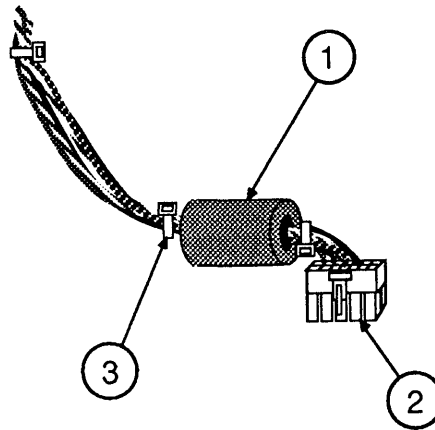

FIGURE 26

1. Position the clip-on ferrite bead (Figure 26, #1) around the video board cable as near the video board connector (Figure 26, #2) as possible. Snap the ferrite bead shut.
2. Install a plastic tie-wrap (Figure 26, #3) on the cable to hold the ferrite bead near the connector. Cut off excess tie-wrap.
3. Place the video ground wire tab over the upper-left CRT mounting bracket and replace the Torx screw (Figure 25, #2). Be sure the ground wire is routed away from the case screw holder (Figure 25, #4).
4. Reconnect the video board connector (Figure 25, #1) to the analog board.

Note: A plastic guide may be installed over the leads on the tip of the CRT. If so, pull the guide off before reconnecting the video board to the CRT.

5. Reconnect the video board (Figure 25, #3) to the neck of the CRT. It fits only one way.

Note: Before replacing the cover, make sure the video picture is adjusted to the right height and width. Refer to the "Size Adjustments" steps under "Video Adjustments" in Section 3.

6. Replace the cover.

□ CATHODE-RAY TUBE (CRT)

Materials Required

Grounded workbench pad and wriststrap
Torx screwdriver

Remove

Follow the steps below to remove the CRT:

1. Remove the cover and discharge the CRT.

WARNING: *Leave your safety goggles on for the remainder of this procedure.*

2. Remove the anode cap.
3. Move the Macintosh SE or Macintosh SE/30 onto a soft, grounded workbench pad and put on your grounding wriststrap. (Never put on the grounding wriststrap until after the CRT is discharged.)
4. Remove the video board.
5. Remove the analog board. (Do not remove the power supply from the analog board.)

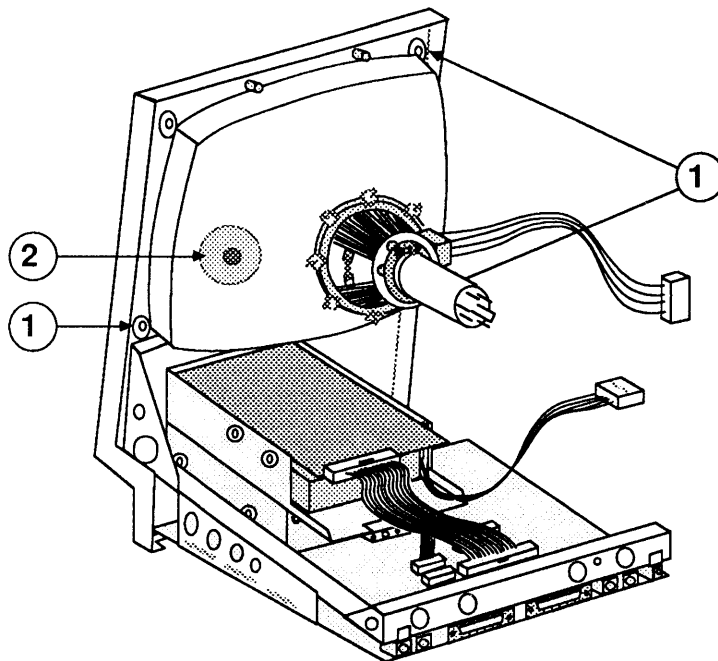

FIGURE 27

6. Using the Torx screwdriver, remove the three remaining mounting screws from the corners of the CRT (Figure 27, #1).
7. Lift the CRT free from the bezel.

Replace

Follow the steps below to replace the CRT:

1. Place the CRT face down in the bezel, with the anode aperture (Figure 27, #2) on the left, as shown.
2. Replace the three CRT mounting screws shown in Figure 27, #1.

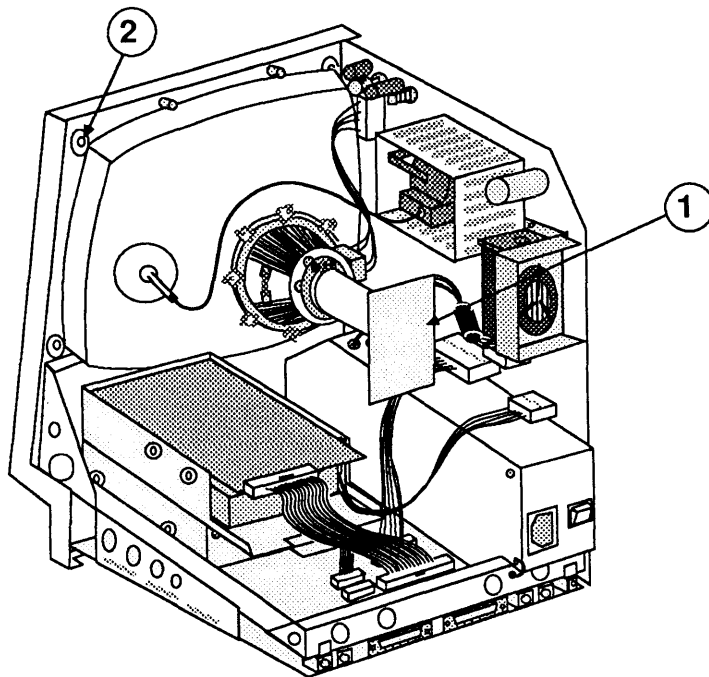
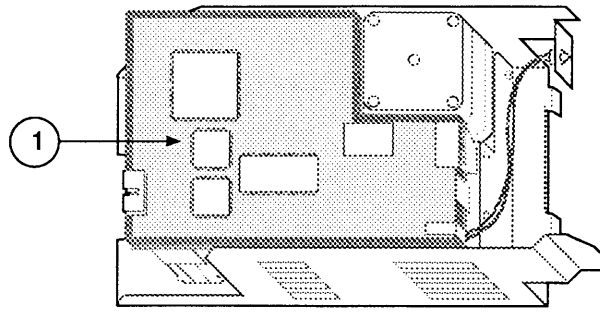

FIGURE 28

3. Replace the analog board/power supply.
4. Replace the video board (Figure 28, #1).

Note: Directions for replacing the fourth CRT mounting screw (Figure 28, #2) are included in the video board procedure.

5. Replace the cover.



Revision A

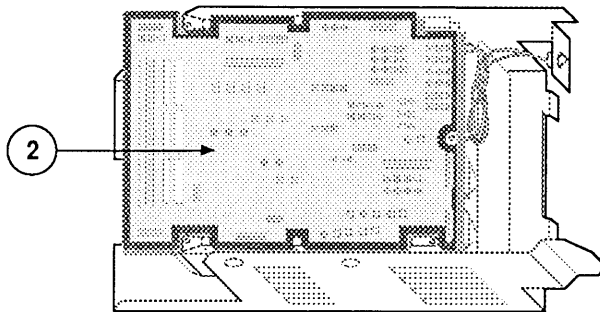

Revision B

FIGURE 29

□ INTERNAL SCSI HARD DISK DRIVE

The Macintosh SE and SE/30 can be configured with a 3.5-inch half-height or a 3.5-inch 1-inch-height SCSI hard disk drive. The procedure for removing all Apple SCSI internal disk drives is the same.

Unlike most drives for the Macintosh SE and SE/30, the 1-inch-height drives are oriented PCB-side down in their carriers; thus, when removing the drive, the SCSI power cable will be opposite its location in Figure 30.

Identifying 20SC Revision A and B Drives

Apple currently ships two versions of the internal Hard Disk 20SC. To the customer, the Hard Disk 20SC Revision A drive and the Hard Disk 20SC Revision B drive are identical, but **20SC Revision A and Revision B drives must be replaced like-for-like**. To differentiate between drive versions, check their circuit boards. For Revision A drives, the component side of the board is up (Figure 29, #1); for Revision B drives, the solder side is up (Figure 29, #2). For part numbers, refer to Illustrated Parts List or your *Apple Service Programs* binder.

Materials Required

Grounded workbench pad and wriststrap
Medium Phillips screwdriver
Torque driver (for 1-inch-height drives)

Remove

Follow the steps below to remove an internal SCSI hard disk drive.

1. Remove the cover and discharge the CRT.
2. Move the Macintosh SE or Macintosh SE/30 onto a soft, grounded workbench pad, and put on your grounding wriststrap. (Never put on the grounding wriststrap until after the CRT is discharged.)
3. Remove the video board.

4. Disconnect the hard disk drive cable from the main logic board (Figure 30, #1).
5. Disconnect the hard disk drive power cable from the analog board (Figure 30, #2).
6. Remove the two Phillips screws that secure the hard disk drive carrier to the lower drive housing (Figure 30, #3), and lift out the hard disk assembly.
7. Before returning the hard disk assembly to Apple, remove the 50-pin SCSI connector cable.

Note: There are a number of ways in which damaged hard drives must be returned to Apple. For information on the appropriate return configuration for your drive, see *SCSI Hard Disk Drives Technical Procedures*.

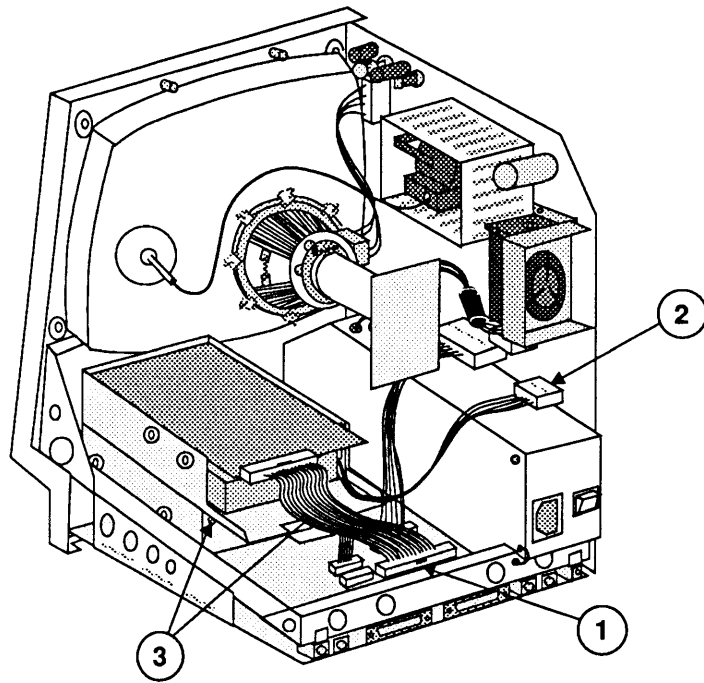

FIGURE 30

Removing the Drive From Its Carrier

To remove a drive from its carrier:

1. Remove the four screws on the lower sides of the carrier (Figure 31).
2. Unplug the LED from the drive, and lift the drive out of the carrier.
3. Package the drive for return to Apple.

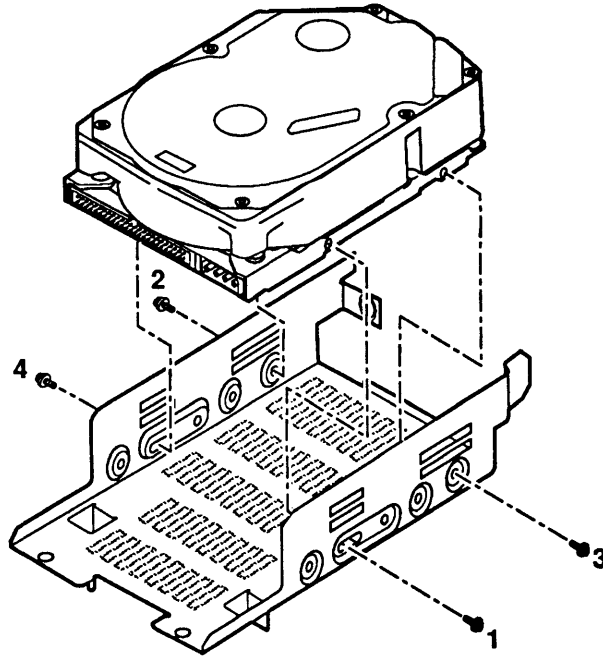

FIGURE 31

Replacing the Drive In Its Carrier

Most drives can be replaced in a carrier by reversing the steps above. Because of the compact nature of 1-inch height drives, special steps are required when tightening the drives into their carriers. Use the following steps to assure the proper functioning and longevity of these drives.

1. Plug the LED into the drive.
2. Using the Phillips screws that you removed in step 1, loosely secure the drive in its carrier.
3. Tighten the screws in the sequence shown in Figure 31, torquing the four screws to 8.0 in-lbs.

Replace

1. Replace the 50-pin SCSI connector cable on the hard disk assembly.

Note: If you are using the carrier with low side-mounting holes (see Figure 31), the key on the hard disk SCSI connector will be inverted. To make the hard disk drive cable fit properly, fold one end of the cable forward and the other end backward into the shape shown in Figure 32.

2. Slide the hard disk assembly over the lower drive so that the tabs on the bottom of the hard drive carrier mesh with the top holes on the lower drive housing.
3. Replace the two screws that secure the hard disk carrier to the lower drive housing (Figure 30, #3).
4. Reconnect the hard disk drive power cable to the analog board (Figure 30, #2).
5. Reconnect the hard disk SCSI connector to the main logic board (Figure 30 #1).
6. Replace the video board.
7. Replace the cover.

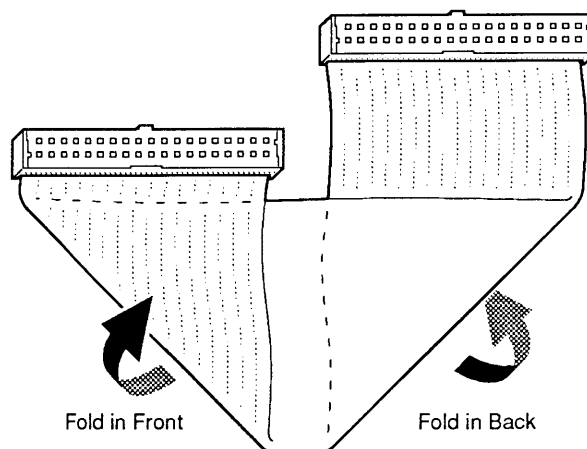

FIGURE 32

□ LED CABLE ASSEMBLY

Materials Required #2 jeweler's screwdriver

Remove To remove the LED cable assembly:

1. Remove the cover and discharge the CRT.
2. Remove the hard disk assembly.

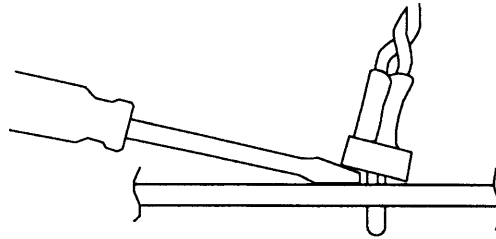

FIGURE 33

3. Pry the small plastic retaining ring from around the LED holder with a jeweler's screwdriver (Figure 33). Slide the retaining ring up the wires and out of the way.

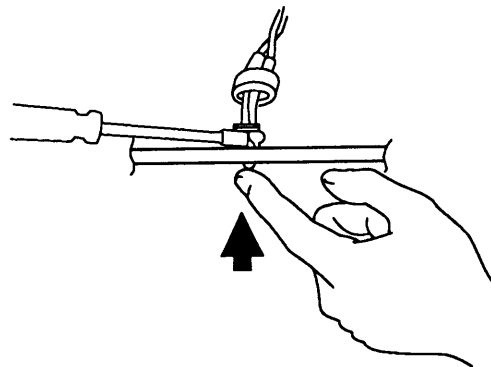

FIGURE 34

4. Press the face of the LED toward the inside of the metal frame while gently prying apart the LED holder with the screwdriver until the LED snaps free of the metal frame (Figure 34).
5. Disconnect the LED connector from the hard drive assembly, and remove the LED cable assembly.

Replace

To replace the LED cable assembly:

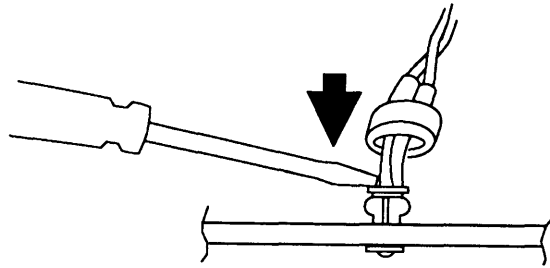

FIGURE 35

1. If necessary, slip the LED into its holder and snap it into place with a jeweler's screwdriver (Figure 35).

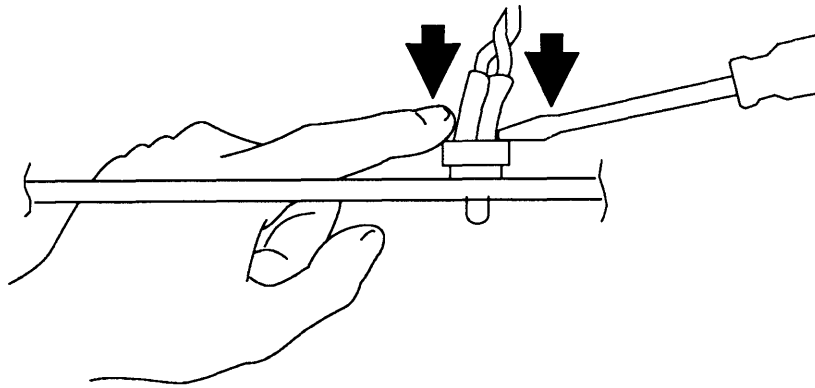

FIGURE 36

2. Slide the retaining ring down the wires and position it around the LED holder. Push the ring back into place with the screwdriver (Figure 36).
3. Connect the LED cable to the LED connector on the controller board.
4. Replace the hard disk assembly.
5. Replace the cover.

□ UPPER INTERNAL DISK DRIVE

Materials Required

Grounded workbench pad and wriststrap
Medium Phillips screwdriver

Remove

Follow the steps below to remove the optional upper internal drive from the Macintosh SE (only):

1. Remove the cover and discharge the CRT.
2. Move the Macintosh SE onto a soft, grounded workbench pad and put on your grounding wriststrap. (Never put on the grounding wriststrap until after the CRT is discharged.)

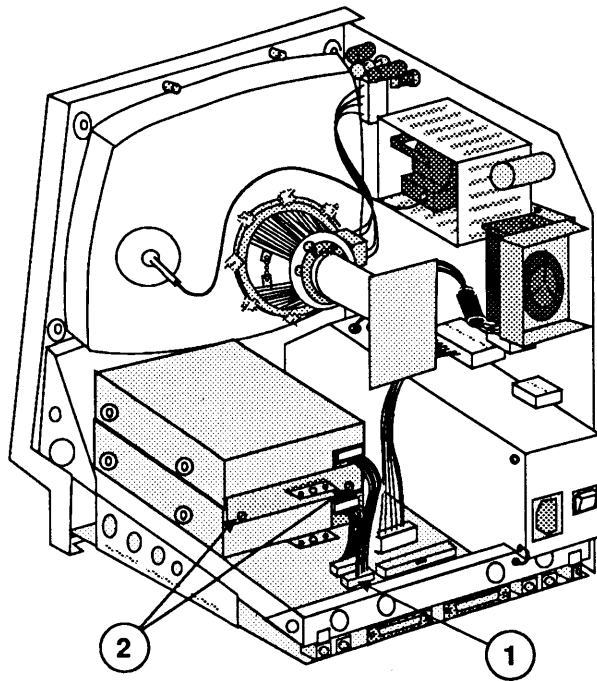

FIGURE 37

3. Remove the video board.
4. Disconnect the upper internal disk drive cable from connector J7 on the main logic board (Figure 37, #1).
5. Remove the two screws (Figure 37, #2) from the metal bracket that holds the two drive housings together. Lift off the metal bracket.
6. Slide the upper internal drive forward and lift it out.

Replace

1. Remove the dummy packing disk from the replacement internal drive mechanism.

IMPORTANT: Apple strongly advises the use of dust shields on 1.4 MB floppy drives in all Macintosh SE and SE/30 computers. All 1.4 MB replacement drives ship with the dust shield already installed. If you plan to install a dust shield on a current drive, however, you **must** clean the drive first. Follow the procedure in "Cleaning the Drive" in the Basics section of the FDHD/SuperDrive tab of the Apple Service Technical Procedures.

2. To place the upper drive into the chassis over the installed lower drive, slide the upper internal drive forward, then back over the lower internal drive so that the tabs on the top of the lower drive housing mesh with the holes on the bottom of the upper drive housing (Figure 38, #1).

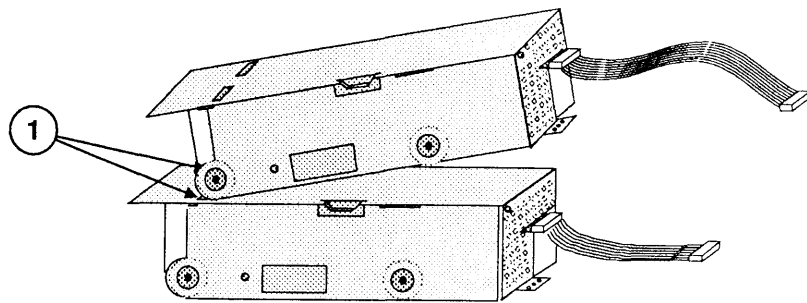

FIGURE 38

3. Place the metal bracket over the two drive housings so that the slot in the bracket (Figure 39, #1) fits over the tab on the upper housing.

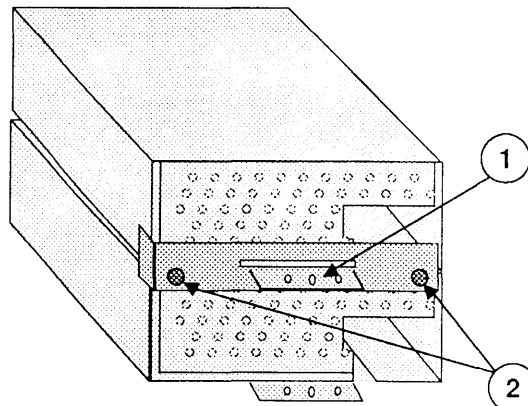

FIGURE 39

4. Replace the two Phillips screws (Figure 39, #2) that secure the metal bracket to the lower internal drive housing.

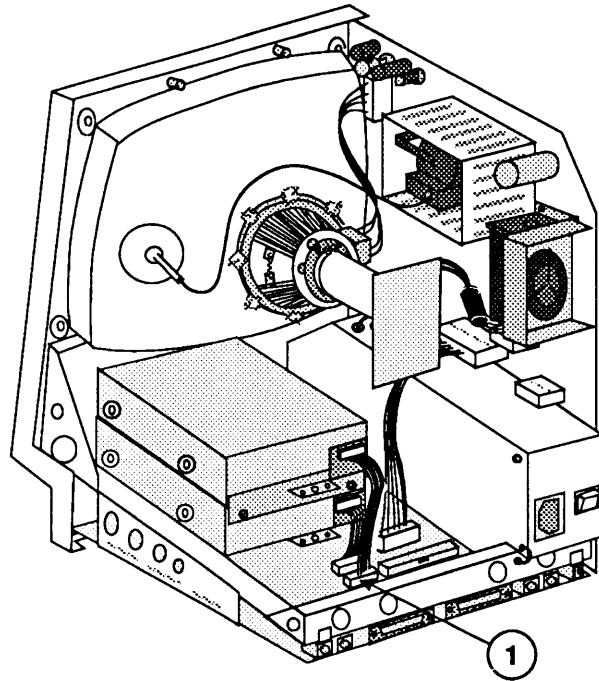

FIGURE 40

5. Reconnect the upper internal disk drive cable to connector J7 on the main logic board (Figure 40, #1).

Note: You must use the longer of the two available yellow-coded internal disk drive cables for the upper drive. The shorter cable will not reach to the main logic board. (The two cables are identical except for length.)

6. Replace the video board.
7. Replace the cover.

□ LOWER INTERNAL DISK DRIVE

Materials Required

Grounded workbench pad and wriststrap
Medium Phillips screwdriver

Remove

Although the disk drives may be different, follow the steps below to remove the lower internal disk drive from a Macintosh SE or from a Macintosh SE/30.

1. Remove the cover and discharge the CRT.
2. Move the Macintosh SE or Macintosh SE/30 onto a soft, grounded workbench pad and put on your grounding wriststrap. (Never put on a grounding wriststrap until after the CRT is discharged.)
3. Remove the video board.
4. Remove the hard disk drive or upper internal drive, whichever is present.
5. Remove the main logic board.

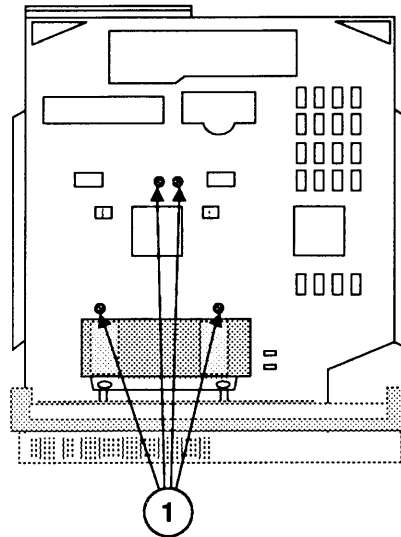

FIGURE 41

6. With the bottom of the chassis facing you, remove the four Phillips screws (Figure 41, #1) that secure the lower internal drive to the bottom of the metal chassis. Lift the drive free.

Replace

1. Remove the dummy packing disk from the replacement drive mechanism.

IMPORTANT: Apple strongly advises the use of dust shields on 1.4 MB floppy drives in all Macintosh SE and SE/30 computers. All 1.4 MB replacement drives ship with the dust shield already installed. If you plan to install a dust shield on a current drive, however, you **must** clean the drive first. Follow the procedure in "Cleaning the Drive" in the Basics section of the FDHD/SuperDrive tab of the Apple Service Technical Procedures.

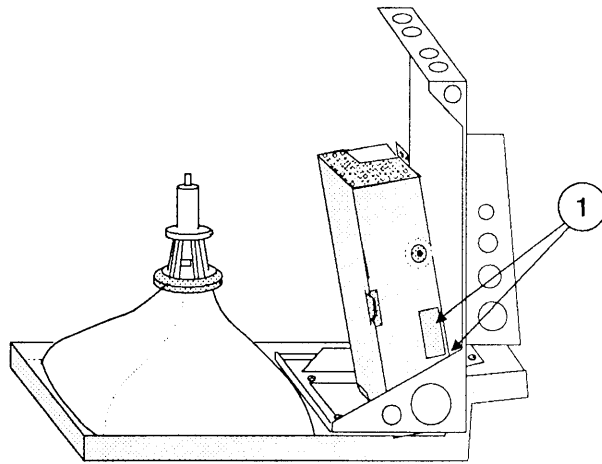

FIGURE 42

2. Place the drive into the chassis so that the tabs on the bottom of the metal drive housing fit into the holes provided in the chassis frame (Figure 42, #1).
3. Replace the four Phillips screws (Figure 41, #1) that secure the internal drive to the bottom of the metal chassis.
4. Replace the main logic board.
5. Replace the hard disk or upper internal drive.
6. Replace the video board.
7. Replace the cover.

□ FAN ASSEMBLY

CAUTION: *There are two fan styles: the older cross-flow (cylindrical) fan and the newer axial (round) fan. The axial fan, since it is wider, must be installed with the redesigned, vertically mounted CRT video board. The axial fan will not allow adequate vibration clearance with the old, horizontally mounted CRT video board.*

Materials Required

Grounded workbench pad and wriststrap
Exacto knife
Soldering iron
Torx screwdriver

Remove

Follow the steps below to remove the fan assembly:

1. Remove the cover and discharge the CRT.
2. Move the Macintosh SE or Macintosh SE/30 onto a soft, grounded workbench pad and put on your grounding wriststrap. (Never put on a grounding wriststrap until after the CRT is discharged.)
3. Remove the video board.
4. Remove the analog board.
5. Remove the power supply from the analog board.
6. Remove the fish paper from the board. (To do this, compress and remove the arrow clips.)
7. The electrical connection of the fan to the analog board has been achieved in several different ways. In most designs, one or two wires from the fan are soldered to the analog board. First check to see if any wires are present. They may be routed along the front (Figure 43, #1) or the back (Figure 44, #1) of the analog board.

If there are **no** fan wires, go to step 8.

If a wire or wires are present, locate the solder point(s) on the back of the board and desolder them. Using the exacto knife, cut away any excess bonding material holding the wire(s) in place.

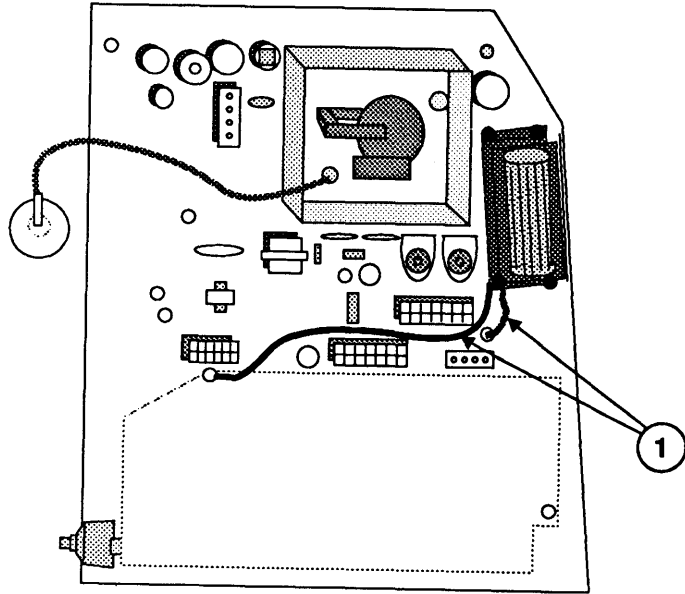

FIGURE 43

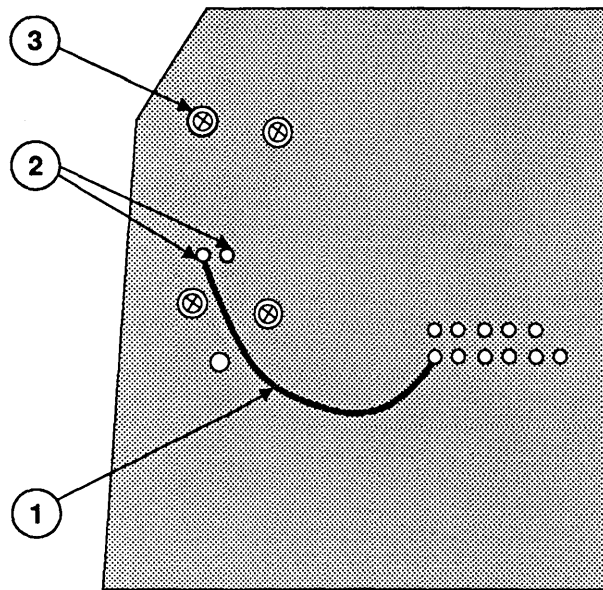

FIGURE 44

8. Next, locate the two solder points (Figure 44, #2) on the back of the board that connect to the fan, and desolder if there is solder present.
9. Remove the four screws (one is shown at Figure 44, #3) that hold the fan assembly to the analog board and lift the fan off.

Replace

1. Orient the new (axial) fan assembly (Figure 45, #1) so that the holes in the bracket match the screw holes on the analog board.

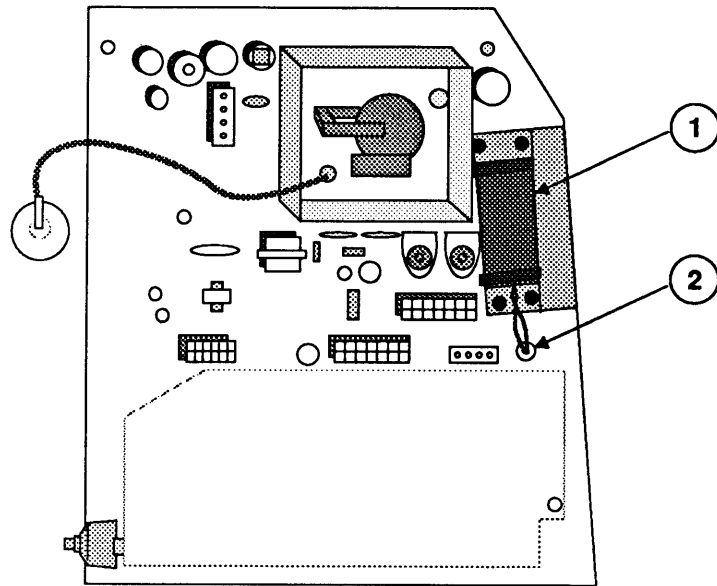

FIGURE 45

2. Holding the fan in place, turn the analog board over and install the four mounting screws (one is shown in Figure 46, #1).

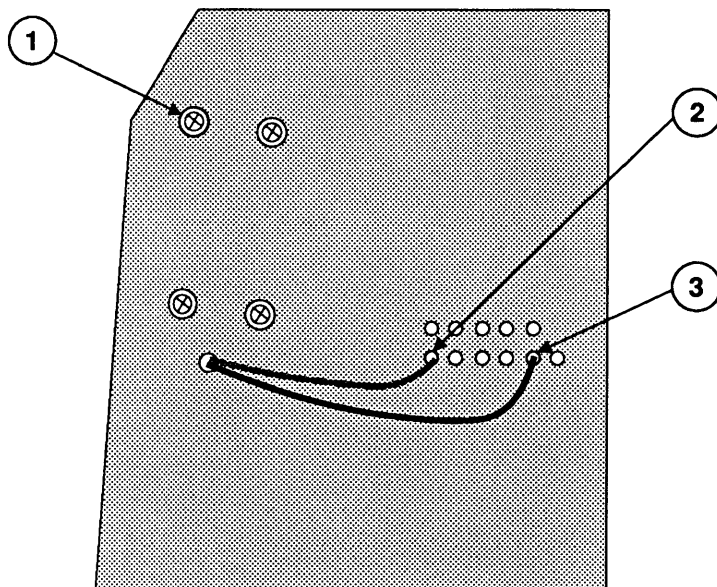

FIGURE 46

3. Route the two fan wires through the hole below the fan on the analog board (Figure 45, #2).

Note: This hole was used for the insertion of one of the arrow clips that hold the fish paper on the board. The arrow clip for this hole can no longer be used.

4. On the noncomponent side of the board, solder the black wire to the first lower solder point (Figure 46, #2) of connector P3.
5. On the noncomponent side of the board, solder the yellow wire to the fifth lower solder point (Figure 46, #3) of connector P3.
6. Replace the fish paper by reinstalling the arrow clips. (Do not put an arrow clip in the hole shown in Figure 45, #2.)
7. Replace the power supply.
8. Replace the analog board.
9. Replace the video board.

CAUTION: *The redesigned, vertically mounted video board must be installed with the new axial fan. The new axial fan will not allow for adequate vibration clearance when installed with the old, horizontally mounted video board.*

10. Replace the cover.

□ SPEAKER, FRONT BEZEL, AND SLOT COVER

Materials Required

Grounded workbench pad and wriststrap
Exacto knife
Soldering iron
Torx screwdriver

Remove

Follow the steps below to remove the speaker, slot cover, or bezel from a Macintosh SE (only):

1. Remove the cover and discharge the CRT.
2. Move the Macintosh SE onto a soft, grounded workbench pad and put on a grounding wriststrap (**after** discharging the CRT).
3. Remove the video board and the main logic board.
4. Remove the analog board. (Do not remove the power supply from the analog board.)

WARNING: *The edges of the metal chassis may be sharp. Handle the metal chassis carefully.*

5. Remove five Torx screws (Figure 47, #1) and lift out the metal chassis with hard disk and/or drive(s).
6. If you are removing the speaker, use an exacto knife to cut away the melted plastic that secures two corners of the speaker to the inside of the front bezel (Figure 48, #1), and lift the speaker out.

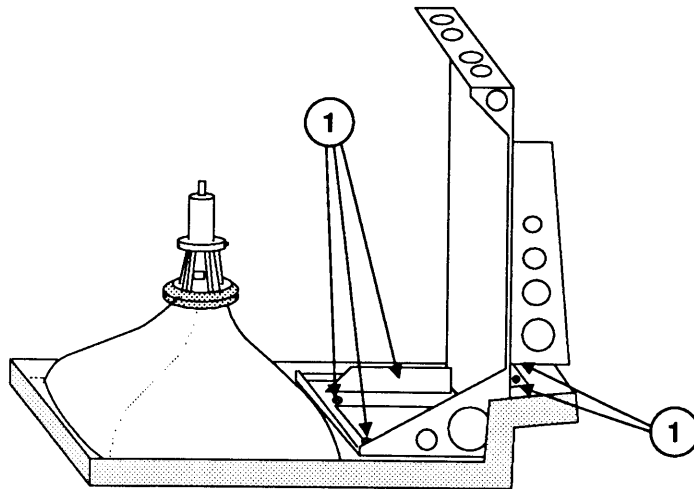

FIGURE 47

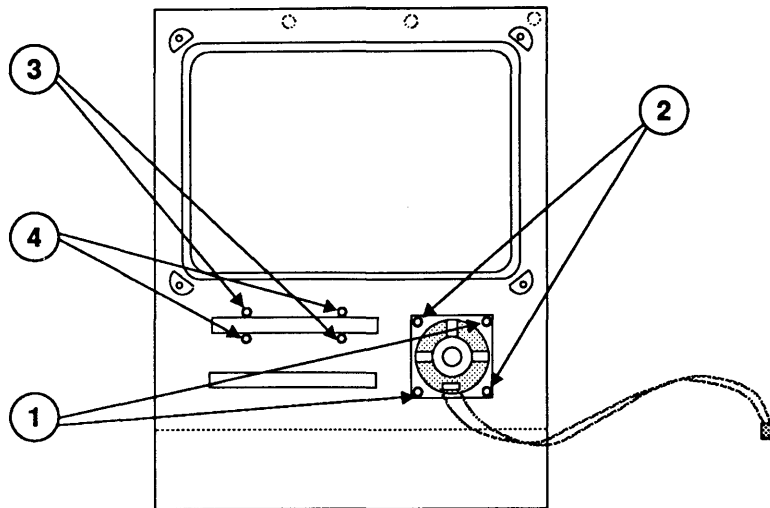

FIGURE 48

7. If you are removing the slot cover from a Macintosh SE, use an exacto knife to cut away the melted plastic that secures two corners of the slot cover to the inside of the front bezel (Figure 48, #3). Gently push the slot cover through the slot and lift it out.
8. If you are removing the bezel, first remove the CRT.

Replace

Follow the steps below to replace the speaker, slot cover, or bezel:

1. Place the bezel face down on the grounded workbench pad.
2. If you are replacing the speaker, position the speaker in the bezel (see Figure 48). Touch a heated soldering iron to the two previously unmelted plastic posts that now protrude through the corners of the speaker (Figure 48, #2). The plastic will spread as it melts, then harden and hold the speaker in place.
3. If you are replacing the slot cover on a Macintosh SE, position the slot cover in the bezel (see Figure 48) with the plastic LED window beside the small hole on the front bezel. Touch a heated soldering iron to the two unmelted plastic posts on the slot cover (Figure 48, #4). The plastic will melt, then harden and hold the slot cover in place.

4. Replace the CRT, if you removed it.

WARNING: The edges of the metal chassis may be sharp. Handle the metal chassis carefully.

5. Replace the metal chassis, with disk and/or SCSI drive(s) attached, and fasten it to the bezel with the five Torx screws (Figure 49, #1).

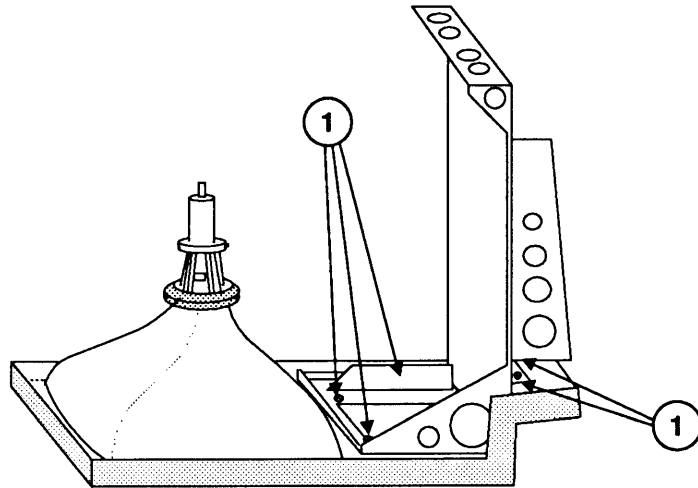

FIGURE 49

6. Replace the analog board.
7. Replace the main logic board.
8. Replace the video board.
9. Replace the cover.

Macintosh SE and Macintosh SE/30

Section 3 – Adjustments

□ CONTENTS

3.2	Yoke Adjustments
3.2	Introduction
3.2	Materials Required
3.3	Tilt Adjustment
3.3	Centering Ring Adjustment
3.4	Video Adjustments
3.4	Introduction
3.4	Materials Required
3.5	Adjustment Procedures

□ YOKE ADJUSTMENTS

Introduction

In infrequent cases, you may need to adjust the yoke of the Macintosh SE or Macintosh SE/30 after you replace the CRT. To see if the yoke needs adjusting, turn the power on and look at the CRT screen. If the picture is tilted, correct it using the tilt adjustment. If the picture is off center, use the centering rings adjustment.

Yoke adjustments are made while standing behind the Macintosh SE or Macintosh SE/30, so you must position a mirror so that you can see the screen. **Because of the high voltage danger, do not try to make live adjustments by facing the screen and reaching around the computer; you can't see what your hands are going to touch.**

Materials Required

Small Phillips screwdriver
Safety goggles
CRT discharge tool
Soft cloth or foam pad
Mirror
Exacto knife

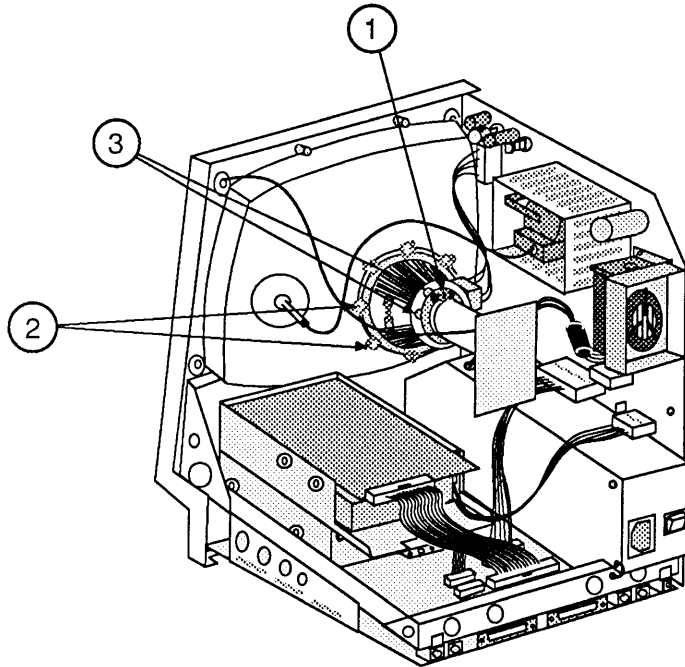

FIGURE 1

WARNING: Read the safety precautions in Section 1, Basics, before performing adjustments. Failure to follow the safety rules could result in serious injury.

Tilt Adjustment

1. Put on safety goggles and remove all metal jewelry. If you are wearing a grounding wriststrap, remove it.
2. Remove the cover and discharge the CRT. (Refer to Section 2, Take-Apart.)
3. Turn the computer with its back facing you, and position the mirror with the CRT screen in the mirror.
4. Loosen the yoke clamp screw (Figure 1, #1) at the top of the CRT neck two or three turns.
5. Connect the power cord and turn the power on.
6. Put one hand behind your back and with your other hand grasp only the plastic spokes of the yoke collar (Figure 1, #2). Rotate the yoke until the top and bottom edges of the picture appear parallel with the top and bottom edges of the bezel.
7. Turn the power off, unplug the computer, and discharge the CRT again.
8. Hold the yoke collar in the position you just determined in Step 6 and carefully tighten the yoke clamp screw just enough so that the yoke cannot slip. Do not overtighten.
9. Replace the cover.
10. Connect the power cord and turn the power on to make sure the tilt adjustment is still correct.

Centering Ring Adjustment

1. Put on safety goggles and remove all metal jewelry. If you are wearing a grounding wriststrap, remove it.
2. Remove the cover and discharge the CRT. (Refer to Section 2, Take-Apart.)
3. Turn the Macintosh SE or Macintosh SE/30 so that its back is facing you, and position the mirror so that the CRT screen is visible in the mirror. ||
4. Locate the two centering rings on the yoke assembly (Figure 1, #3). The adjustment of these rings determines whether the picture is centered or offset to one side.

Note: If a bonding material is holding these rings in place, break it using an exacto knife.
5. Connect the power cord and turn the power on.

6. Center the picture by first holding the front centering ring steady and moving the rear ring, then holding the rear ring steady and moving the front ring.
7. When the picture is perfectly straight and centered, turn the power off, remove the power cord, and again discharge the CRT.
8. Replace the cover.
9. Plug in the power cord, turn the computer power on, and view the screen to ensure that the centering adjustment is still correct.

□ VIDEO ADJUSTMENTS

Introduction

Video adjustments **may** be necessary whenever the CRT, the analog board, the video board, or the power supply is replaced.

Materials Required

Safety goggles
Plastic alignment tool (or "tweaker")
Mirror
Ruler

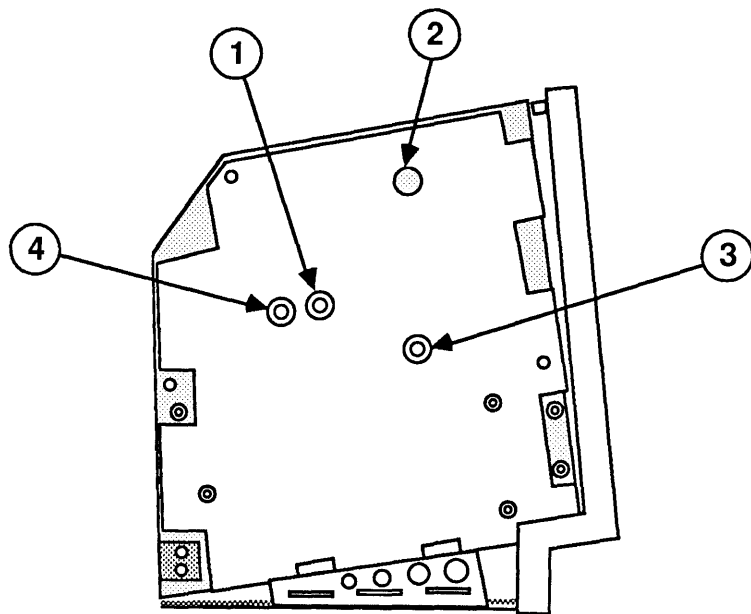

FIGURE 2

Adjustment Procedures

1. Put on safety goggles and remove all metal jewelry. If you are wearing a grounding wriststrap, remove it.
 2. Remove the cover and discharge the CRT. (Refer to Section 2, Take-Apart.)
 3. Turn the computer with the side of the analog board facing you, and position the mirror so that the CRT screen is visible in the mirror.
 4. Connect the power cord and turn the power on.
- Brightness and Contrast
5. Turn the contrast control fully clockwise. (The contrast control is on the front of the computer, on the left side, under the Apple logo.)
 6. Adjust the brightness control (Figure 2, #1) with the alignment tool: turn it fully counterclockwise so that white lines are visible on the screen. Then turn it back in the opposite direction until the white lines just disappear.
 7. Turn the contrast control on the front panel slightly counterclockwise. This is the ideal adjustment.
- Size Adjustments
8. Use the plastic alignment tool to adjust the width (Figure 2, #2) until the picture is approximately 7 inches wide.
 9. Use the plastic alignment tool to adjust the height (Figure 2, #3) until the picture is approximately 4.7 inches high.
- Focus Adjustment
10. Turn the focus adjustment (Figure 2, #4) all the way clockwise until it doesn't turn anymore. Now turn it back in the opposite direction (counterclockwise) one-eighth of a turn. This setting gives the best overall sharpness at all points on the screen.



Macintosh SE and Macintosh SE/30

Section 4 – Diagnostics

□ CONTENTS

- 4.2 Introduction to *MacTest SE* and *MacTest SE/30*
- 4.2 Program Similarities
- 4.3 Program Differences
- 4.4 Making Backup Disks
- 4.4 Copying *MacTest SE* and *MacTest SE/30* Disks
- 4.6 Running *MacTest SE* and *MacTest SE/30*
- 4.6 Materials Required
- 4.6 Starting *MacTest SE* and *MacTest SE/30*
- 4.8 Installing the Loopbacks
- 4.9 Using the *MacTest SE* and *SE/30* Menus
- 4.14 Running the Tests
- 4.16 Introduction to *AppleCAT SE* and *AppleCAT SE/30*
- 4.17 Running *AppleCAT SE* and *AppleCAT SE/30*
- 4.17 Materials Required
- 4.17 Setting Up Test Station and UUT
- 4.20 Establishing Communication
- 4.22 Using the *AppleCAT* Menus
- 4.26 Running the Tests
- 4.28 Repair Confirmation Codes
- 4.29 SCSI Loopback Jumper Procedure
- 4.29 To Determine If a Jumper Is Needed
- 4.30 To Install the Jumper

□ INTRODUCTION TO MACTEST SE AND MACTEST SE/30

MacTest™ SE (version 3.0 or higher) is part of the *AppleCAT™ SE* diagnostic set that is used for testing Macintosh SE systems. *MacTest SE/30* (version 1.0 or higher) is part of the *AppleCAT SE/30* diagnostic set for testing Macintosh SE/30 systems. Both *MacTest SE* and *MacTest SE/30* may also be used as standalone functional tests of their respective systems.

Program Similarities

When used as standalone tests, *MacTest SE* and *MacTest SE/30* perform pass/fail functional tests of the Macintosh SE and Macintosh SE/30 systems, respectively. *MacTest SE* and *MacTest SE/30* are run the same, but *MacTest SE/30* tests Macintosh SE/30 components that do not exist in the Macintosh SE.

Initially, both *MacTest SE* and *MacTest SE/30* allow you to select the tests you want to run. As each test progresses, messages on the screen indicate which area is under test. As soon as a failure is detected, the test stops and the screen indicates which module must be replaced before the test can be run to completion. The test then terminates and returns to the Finder (desktop).

Both *MacTest SE* and *MacTest SE/30* also provide test patterns for use in adjusting the CRT. **Neither *MacTest SE* nor *MacTest SE/30* tests an internal SCSI hard disk.** To test the hard disk, use the *Macintosh Hard Disk Drive Diagnostic* disk (see Section 3, Diagnostics, in the *SCSI Hard Disk Drives Technical Procedures*).

Program Differences

Because of configuration differences between the Macintosh SE and Macintosh SE/30 systems (see Basics), *MacTest SE* and *MacTest SE/30* test different components.

Components Tested by MacTest SE

MacTest SE tests the following Macintosh SE components:

- Macintosh SE main logic board, including:
 - RAM
 - VIA
 - SCC
 - Clock
 - Sound chip
- Internal and external disk drives
- Keyboard and mouse
- SCSI bus
- Apple PC 5.25 Drive and Macintosh SE-Bus PC Card

The internal 96-pin Euro-DIN expansion bus connector on the Macintosh SE logic board cannot be tested unless an expansion card is connected to the expansion bus. When a Macintosh SE-Bus PC Card and an Apple PC 5.25 Drive are installed, *MacTest SE* can test the card, drive, and expansion bus at the same time.

Components Tested by MacTest SE/30

MacTest SE/30 tests the following Macintosh SE/30 components:

- Macintosh SE/30 main logic board, including:
 - RAM
 - VIA
 - SCC
 - PMMU
 - FPU
 - Clock
 - Sound chip
- Internal and external disk drives
- Keyboard and mouse
- SCSI bus
- Video RAM

□ MAKING BACKUP DISKS

Make a backup of the original *MacTest SE* or *MacTest SE/30* diagnostic disk before you begin! When testing a defective Macintosh SE or Macintosh SE/30, it is possible to damage or erase a section of the *MacTest* disk.

You can make backup copies on any Macintosh, regardless of which *MacTest* program you are copying. For example, you can copy the *MacTest SE* disk using a Macintosh Plus or a Macintosh II. The copy does not have to be made on the Macintosh SE.

Copying MacTest SE and MacTest SE/30 Disks

Use Finder to make a backup copy of the *MacTest SE* or *MacTest SE/30* diagnostic disk. When copying the *MacTest SE* or *MacTest SE/30* disk, be sure to **copy the entire disk** and not just the *MacTest* program. The *MacTest SE* and *MacTest SE/30* disks contain specific versions of the System and Finder, and are not guaranteed to run with other versions. Also, **be sure to copy *MacTest SE* and *MacTest SE/30* to 800K disks only.**

Using Your Backup Disk

Take the following precautions when using your *MacTest SE* or *MacTest SE/30* disk copy:

- **Do not write-protect your working copy of the *MacTest SE* or *MacTest SE/30* disk.** The program will not run correctly if you do.
- **Do not replace the System or Finder provided on the *MacTest* disk.** The versions used on the disk are Finder 6.1 and System 6.0.2. *MacTest SE* and *MacTest SE/30* are not guaranteed to work with other versions of the System and Finder.

- **Do not change the name of the diagnostic program on the disk.** During logic board testing, the machine reboots, looks for, and restarts the diagnostic named *MacTest SE* (or *MacTest SE/30*, if you are testing that system). If the name has been changed, the startup routine will not be able to locate it, and the system will stay on the desktop.

Therefore, if the *MacTest SE* or *MacTest SE/30* window does not reappear after a logic board test, check the name of the diagnostic's icon on the desktop. Correct it to *MacTest SE* (or *MacTest SE/30*), and then select **Set Startup** from the desktop **Special** menu. When you are asked if you wish to change the name of the startup application to *MacTest SE* (or *MacTest SE/30*), click **OK**. Then double-click on the corrected *MacTest SE* or *MacTest SE/30* icon to return to the test program.

□ RUNNING MACTEST SE AND MACTEST SE/30

Materials Required

MacTest SE or *MacTest SE/30* diagnostic disk (backup)
Mini-DIN-8-to-mini-DIN-8 serial port cable
SCSI loopback test card (modified with jumper—see
"SCSI Loopback Jumper Procedure")
Blank, 800K disk for drive test
Blank, 1.4 MB disk for high-density drive test

Starting MacTest SE and MacTest SE/30

You can use *MacTest SE* or *MacTest SE/30* to perform a functional test of the entire Macintosh SE or Macintosh SE/30 system (respectively), or you can use it to test a single component in a known-good system. Follow the start-up steps below for the testing you wish to perform.

Testing Complete System or Logic Board

1. If you are testing a complete Macintosh SE or Macintosh SE/30 system, or if you intend to run the logic tests, turn the power off and remove any card installed in the expansion slot.
2. Install the loopback connectors as described under "Installing the Loopbacks," later in this section.
3. Insert the appropriate *MacTest* disk into the internal drive, and power on the system. *MacTest* will display the Start, or Status, window. From the Status window, you can click **Start** to run the tests.

Testing Single Component

1. If you are testing a single component in a known-good system, insert the appropriate *MacTest* disk into the internal drive and switch on system power.
2. *MacTest SE* and *MacTest SE/30* will display a window telling you to switch off system power and connect the SCSI loopback cable. The SCSI loopback cable must be connected *only* when you are running the logic board tests. If you do not need to connect the SCSI loopback cable, click **OK** to get to the Status window.
3. From the Status window, you can use the *MacTest* menus. Go to the **Options** menu and use the **Test Selections** submenu to select the tests you want to run. Then click **Start**. For more specific information on the tests, see "Using the *MacTest SE* and *SE/30* Menus" and "Running the Tests," later in this section.

Helpful Startup Information

1. If you do not know whether the system you are testing is good, remove any expansion cards and run the logic, drive, and video RAM (Macintosh SE/30 only) tests. (See "Using the *MacTest SE* and *SE/30* Menus" and "Running the Tests," later in this section.) Complete any needed repairs before you continue.
2. If you removed a non-Apple expansion card from the customer's system and the system tests OK, switch off system power and replace the card. Then run the logic, drive, and video RAM (Macintosh SE/30 only) tests again to be sure the card is not interfering with the system operation.
3. If you want to test an Apple PC Card or an Apple PC 5.25 Drive (Macintosh SE only), run the Apple PC 5.25 Drive test as described in Section 3, Diagnostics, of the *Apple PC 5.25 Drive Technical Procedures*.
4. If you encounter any of these problems, try the solution that follows each problem:
 - **A known-good *MacTest SE* or *MacTest SE/30* disk will not boot:** Refer to Section 5, Troubleshooting.
 - **The Configuration window indicates that an attached disk drive is not installed:** Check the disk drive cables.
 - **The Configuration window indicates that the wrong amount of RAM is installed:** Check SIMM placements in the SIMM banks. For a Macintosh SE, also check the position of resistors/jumpers on the logic board. Refer to Section 6, Additional Procedures.
 - **The Configuration window indicates that an upper internal drive is a lower internal drive (or vice versa):** Check the installation of the internal drive cables.
 - **A known-good *MacTest SE* or *MacTest SE/30* disk will not boot:** Refer to Section 5, Troubleshooting.

Installing the Loopbacks

Before beginning *MacTest SE* or *MacTest SE/30*, and **with the power off**, connect the serial loopback cable, the SCSI loopback card, the keyboard and mouse, and the external drive (optional).

CAUTION: Always power off the system when you connect or disconnect the SCSI loopback card.

The SCSI loopback card (Figure 1, #1) must be connected to the SCSI port (Figure 1, #2) on the back of the system. (No other connections between the card and the Macintosh SE or Macintosh SE/30 are necessary.) To protect the SCSI circuitry, you must have the power off when you connect the SCSI card.

Note: When the SCSI loopback card is connected, the internal SCSI hard disk will not be able to respond, nor will it be recognized by the system.

The loopback cable (Figure 1, #3) with the mini DIN-8 connectors must be installed between the modem and printer ports (Figure 1, #4) on the rear of the machine.

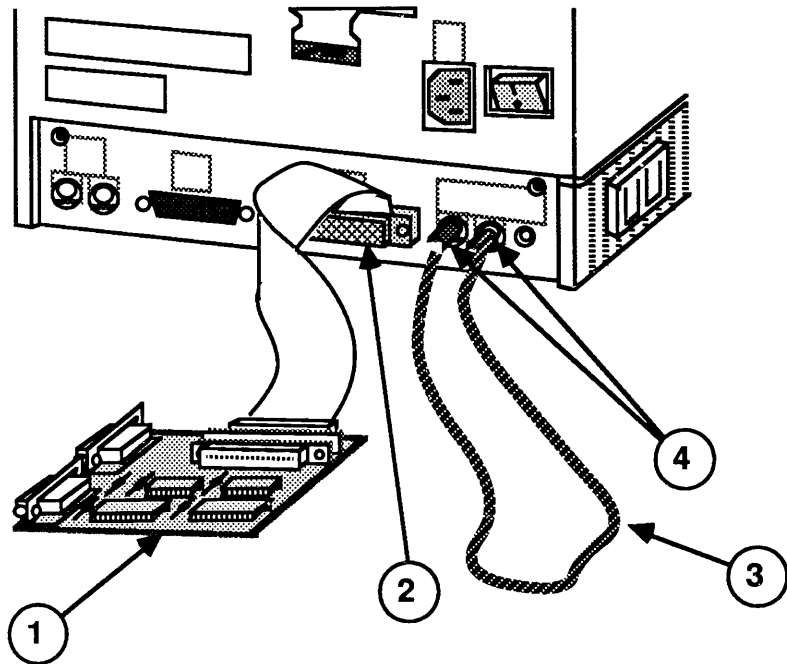

FIGURE 1

Using the MacTest SE and SE/30 Menus

Before you start *MacTest SE* or *MacTest SE/30*, you may use the *MacTest* menus to select the tests that you want to run or to select other features of the diagnostic. **You cannot use the menu when the tests are running.**

Options Menu

The **Options** menu contains the **Test Selections** and **Configuration** submenus.

1. **Test Selections:** The **Test Selections** windows displayed by *MacTest SE* (Figure 2) and *MacTest SE/30* (Figure 3) differ slightly, but the process of selecting tests is the same for both programs.

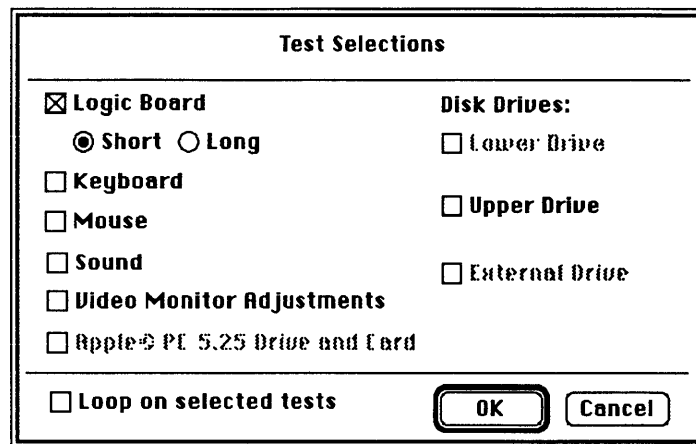

FIGURE 2

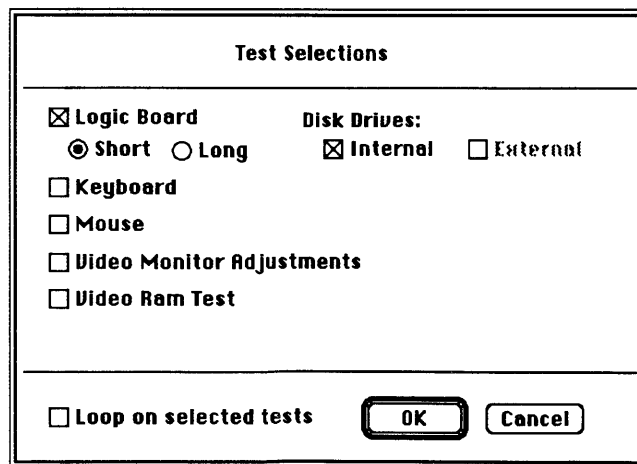

FIGURE 3

Test Selections allows you to select the tests you wish to run. To select a test, click in the box next to the name of the item to be tested (an **X** appears). To deselect the test, click again in the box (the **X** disappears). When you have selected all the tests you wish, click **OK** to return to the *MacTest* Status window.

a) **Logic:** This test will verify the correct functioning of the following circuitry on the logic board:

- VIA (Versatile Interface Adaptor)
- SCC (Serial Communications Chip)
- Clock
- SCSI bus
- RAM
- FPU (Floating-Point Unit) (Macintosh SE/30 only)
- PMMU (Paged Memory Management Unit) (Macintosh SE/30 only)

You may select a short or long logic test. The running time of the test will vary depending on how much memory is installed. At the beginning of the RAM test, *MacTest SE* and *MacTest SE/30* will indicate the maximum running time of the test.

b) **Keyboard:** This selection activates the keyboard self-tests that verify the functioning of the keyboard.

c) **Mouse:** This selection activates the mouse self-tests that verify the functioning of the mouse.

d) **Disk Drives:** You may test any or all of the drives (except internal or external hard disks):

- Lower
- Upper (Macintosh SE only)
- External

Note: The diagnostic will not test an external disk drive that is connected through a non-SCSI Hard Disk 20.

e) **Video RAM (Macintosh SE/30 only):** This selection tests the 64K of video RAM. Be aware that video patterns will flash across your screen during this test.

- f) **Video Monitor Adjustments:** This selection displays test patterns that are used to adjust the video picture on the monitor. After making any necessary video adjustments, click the mouse or hit any key to continue testing or to return to the *MacTest SE* or *MacTest SE/30* window.
- g) **Sound:** This option provides two tests that verify the proper functioning of the Macintosh SE and Macintosh SE/30 sound chip:
- **8-Level Volume Test:** produces 8 tones of increasing volume.
 - **C Scale:** produces a C-major scale.
- h) **Apple PC 5.25 Drive (Macintosh SE only):** This test verifies the correct functioning of the drive, the Apple PC Card, and the expansion port on the main logic board. To set up for this test, follow the instructions in Section 3, Diagnostics, of the *Apple PC 5.25 Drive Technical Procedures*.
- Note:** The Apple PC 5.25 Drive test cannot always determine which module caused a test to fail. If the test reports that the drive and/or card is bad, replace one module at a time as described in Section 5, Troubleshooting, of the *Apple PC 5.25 Drive Technical Procedures*.
- i) **Loop on selected tests:** This selection provides a continuous running (in sequence) of all selected tests. To stop the looping, click **Stop** between tests (that is, when the screen displays an arrow rather than a wristwatch).

Here are a few simple guidelines to keep in mind when preparing to perform loop tests:

- You cannot loop on Video Monitor Adjustments.
- You cannot loop on *both* the Logic Board and Disk Drives tests at the same time.
- When loop-testing a disk drive with more than one possible data format (FDHD), you can select only one format to loop on.

2. **Configuration:** When **Configuration** is selected, *MacTest SE* displays the window shown in Figure 4, and *MacTest SE/30* displays the window shown in Figure 5.

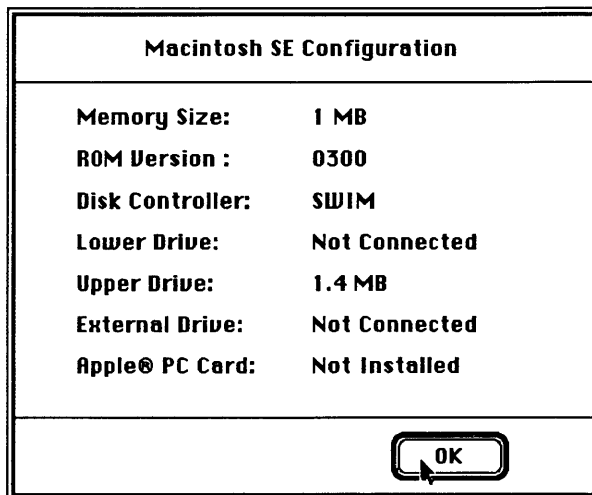

FIGURE 4

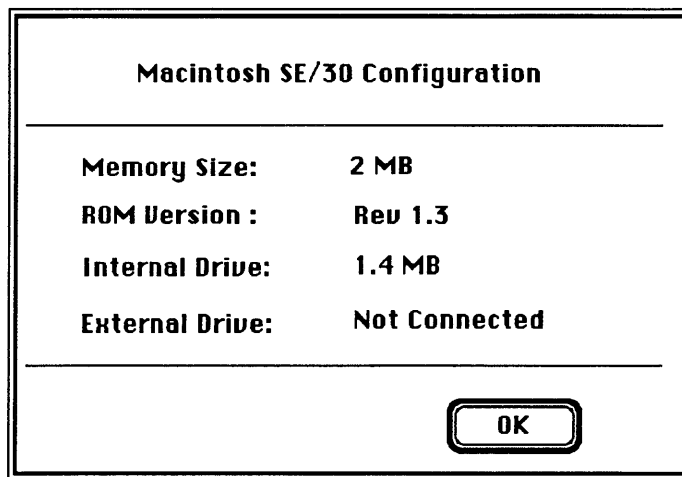

FIGURE 5

The two **Configuration** windows display slightly different information. The *MacTest SE* window indicates the amount of memory in the Macintosh SE, the version number of its ROMs, the type of disk controller chip installed, its current disk drive configuration, and whether or not an Apple PC card is installed. The *MacTest SE/30* window displays the amount of memory in the Macintosh SE/30, the version number of its ROMs, and its current disk drive configuration.

File Menu

The **File** menu displays the following items. (**Open** and **Close** are dimmed.)

- **Open...** [Command-O]
 - **Close** (Dimmed unless a desk accessory is open)
 - **Save Test Selections** [Command-S]
 - **Stop** [Command-.]
 - **Quit** [Command-Q]
1. **Save Test Selections:** Allows you to customize your *MacTest* disk by saving your selection of tests for the next time you use *MacTest SE* or *MacTest SE/30*.
 2. **Stop:** Ends the diagnostic and returns to the *MacTest* Status window.
 3. **Quit:** Returns you to the desktop.

Apple Menu

The Apple (🍏) menu contains the following items. (**Chooser** and **Find File** are shown, but they are inactive.)

1. **About MacTest™ SE** or **About MacTest™ SE/30.** When selected, a dialog box displays the diagnostic name, version number, date of release, serial number, and a copy-protect statement.
2. **Control Panel.** This option allows you to set preferences for speaker volume, monitor status, mouse tracking, or desktop pattern.
3. **Key Caps.** When selected, **Key Caps** displays a window with a keyboard. Press each key on the keyboard and verify that the display block for the key is highlighted. If the key is not highlighted, the keyswitch is bad and should be replaced. If numerous keys are not highlighted, exchange the keyboard.

Running the Tests

After using **Test Selections** to select the tests you wish to run, you are ready to start *MacTest SE* or *MacTest SE/30*. Click **Start** in the Status window. Please note the following:

- The Status line at the bottom of the window will keep you informed of the tests being performed and the test results.
- While running, all tests display a wristwatch. There is no other moving or flashing indicator that tells you the test is in progress.
- When testing the logic board with a SCSI loopback card that is missing or improperly installed, testing will begin but the SCSI port test will fail. You must switch off system power, disconnect all external SCSI drives, and connect the SCSI loopback card before continuing the test.
- When testing the logic board, if the serial loopback cable is missing or improperly installed, the testing will begin but the serial ports test will fail. You will be instructed to connect a serial loopback cable and then to click **OK** to retry the failed test. (You can connect the serial loopback cable without shutting down the system.)
- The RAM test causes several seconds of startling graphics to be displayed on the screen before the program reboots to the *MacTest* Status window.

- When testing the FDHD disk drive, you will be prompted to insert and remove blank 800K and high-density (1.4 MB) disks. Perform the disk swaps as directed on the screen, and then click **OK**.

Note: It is important to insert the requested low- or high-density disk. If the wrong disk is inserted, *MacTest SE* and *MacTest SE/30* will indicate that the disk drive is malfunctioning when it may not be.

CAUTION: Do not press the reset or interrupt switch while the RAM test is running. Pushing reset causes the RAM test to fail, and pressing interrupt may damage the MacTest disk.

- You may halt the testing by clicking **Stop** or **Pause** anytime *between* tests (when the cursor is an arrow, rather than the wristwatch).
 - Choose **Stop** to halt the testing and to return to the Status window. Choose **Start** when you wish to begin the testing sequence again.
 - Choose **Pause** if you wish to discontinue testing temporarily. Choose **Continue** to resume the tests from the point of interruption.

Note: **Pause**, the default option, can also be selected **during** testing by pressing the <Enter> or <Return> keys. The program will act upon the Pause command when it is between tests.

Replace any module that the test indicates is faulty (see Section 2, Take-Apart). Before replacing the module, use *AppleCAT SE* or *AppleCAT SE/30* (whichever is appropriate) or refer to Section 5, Troubleshooting, to verify the diagnosis. If the system is still not operating properly, turn to Section 5, Troubleshooting, for more information.

If all tests pass, the Macintosh SE or Macintosh SE/30 will return to the Status window. The message **All selected tests have passed** will be displayed on the Status line.

□ INTRODUCTION TO APPLECAT SE AND APPLECAT SE/30

AppleCAT™ SE and *AppleCAT™ SE/30* are diagnostic tools that use a known-good Macintosh to diagnose module failures in a defective Macintosh SE or Macintosh SE/30, respectively. The machine doing the testing, or test station, is connected to the machine being tested, or Unit Under Test (UUT), through their communication ports. The test station, when booted with the *AppleCAT SE* or *AppleCAT SE/30* diagnostic program, performs the following functions:

- Establishes communications with the UUT
- Calls tests in the UUT ROM
- Downloads tests to the faulty machine
- Calls tests from the *MacTest SE* or *MacTest SE/30* disk in the UUT disk drive
- Displays test results on the test station screen
- Identifies the failing module
- Prompts the technician for information
- Recommends a repair procedure
- Issues a repair confirmation code (RCC)

Using *AppleCAT SE* or *AppleCAT SE/30*, the machine being tested does not have to be fully operational. By using an independent, working computer to do the diagnosis, the *AppleCAT* diagnostic programs depend very little on the unit under test (UUT), and are more reliable and thorough than traditional diagnostic methods.

Standard windows guide the technician through each stage of the diagnostic. When the UUT fails a test or indicates a problem, an *AppleCAT SE* or *AppleCAT SE/30* window will ask for more information or recommend a repair.

After each module replacement or adjustment, *AppleCAT SE* and *AppleCAT SE/30* rerun the failed test to verify that the problem has been fixed. If the UUT successfully completes this final test, the *AppleCAT* programs issue a repair confirmation code (RCC).

□ RUNNING APPLECAT SE AND APPLECAT SE/30

Materials Required

Known-good Macintosh test station
Programmer's switch for the UUT
Mini-DIN-8-to-mini-DIN-8 serial port cable (590-0552)
SCSI loopback card
Mini DIN-8 serial loopback plug
Torx screwdriver
Macintosh take-apart tool
CRT discharge tool
#0 Phillips screwdriver
#1 Phillips screwdriver

Macintosh SE Materials Required

Macintosh SE (unit under test or UUT)
AppleCAT™ SE diagnostic disk
MacTest™ SE disk (write-protected)
Blank, 800K disk
Blank, 1.4 megabyte disk

Macintosh SE/30 Materials Required

Macintosh SE/30 (unit under test or UUT)
AppleCAT SE/30 diagnostic disk
MacTest™ SE/30 disk (write-protected)
Blank, 800K disk
Blank, 1.4 megabyte disk

Setting Up Test Station and UUT

1. Connect the test station to a wall socket with an AC power cord.
2. Place the UUT next to the test station.
3. Connect the UUT to a wall socket with an AC power cord.

CAUTION: Always power off the system when you connect or disconnect the SCSI loopback card.

4. Connect the SCSI loopback card to the SCSI port (Figure 6, #1) on the UUT.
5. Connect the serial loopback plug to the printer port (Figure 6, #2) on the UUT.

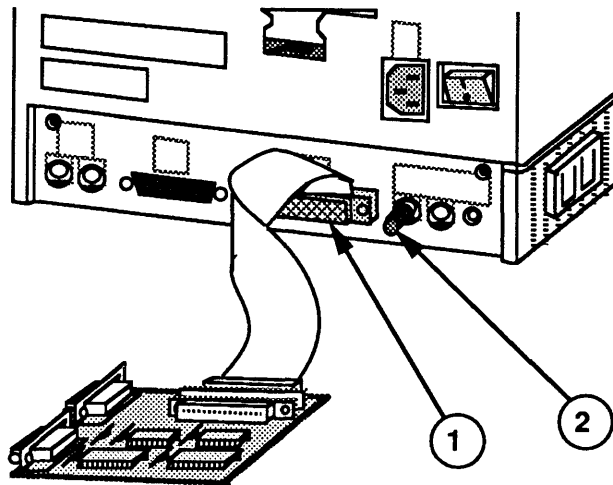

FIGURE 6

6. Connect one end of the serial port cable to the modem port on the UUT; connect the other end to the modem port on the test station (Figure 7).

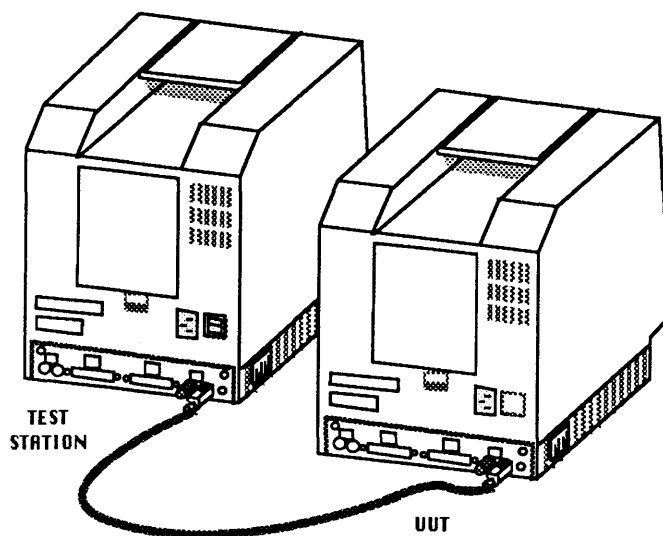

FIGURE 7

7. Connect a keyboard or mouse to the UUT.
8. Verify that the programmer's switch (Figure 8) is installed. With the front of the UUT facing you, insert the two short tabs of the programmer's switch into the 6th and 7th **open** slots from the back, along the left side of the UUT. Push the switch until it snaps into place or you are certain it is secure.

The programmer's switch has two parts. The front part of the switch is a reset switch. Pressing the reset switch is just like turning the power switch **off** and back **on**. The back part of the switch is an interrupt switch. Pressing the interrupt switch places the UUT in interrupt mode.

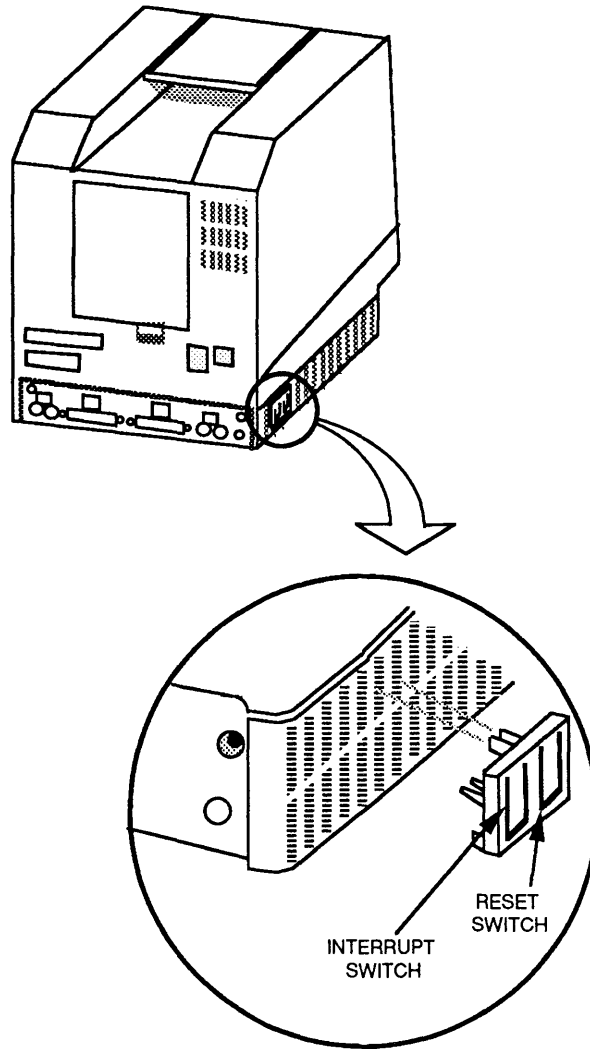

FIGURE 8

Establishing Communication

1. Insert the *AppleCAT SE* (if testing a Macintosh SE) or *AppleCAT SE/30* (if testing a Macintosh SE/30) disk in the test station, and switch on system power.
2. Open the disk icon and then the *AppleCAT* icon. The Start, or Status, window will appear on the test station screen.
3. Be sure that all disks are ejected from the UUT.
4. Switch on system power at the UUT.

For a Macintosh SE: If the video is normal, the Macintosh SE (UUT) will briefly display a blank gray screen with an arrow. When this screen appears, press the interrupt switch (Figure 9) to enter interrupt mode. (You may have to press the interrupt switch 3 to 5 times!) When in interrupt mode, the UUT can respond to information received over the communication port. You will know you are in interrupt mode when the screen displays the "sad Macintosh" icon.

If the UUT screen is completely dark, or if bars or stripes are displayed, there may be a problem with the video. If the above occurs, wait about 4 seconds per megabyte of installed memory, and then press the interrupt switch to enter interrupt mode.

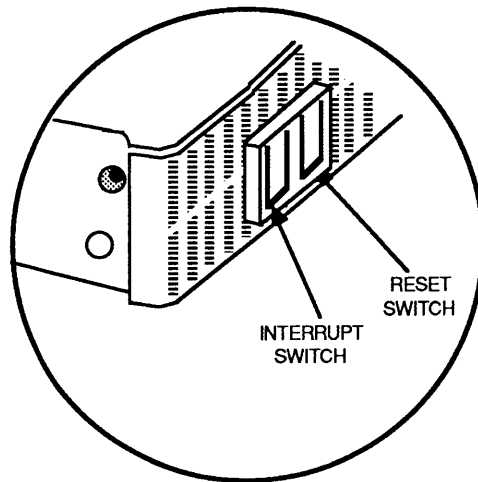

FIGURE 9

For a Macintosh SE/30: If you hear **only** the boot tone (a single chord), you are **not** in interrupt mode. To get into interrupt mode, wait until an arrow appears in the upper-left corner of the UUT (Macintosh SE/30) screen (about 4 seconds per megabyte of installed memory), and then press the interrupt switch (Figure 9). When in interrupt mode (test mode), the UUT can respond to information received over the communication port.

IMPORTANT: *If you hear any additional chords (chimes) after the single boot tone, you are already in interrupt/test mode. Do not hit the interrupt switch. The Macintosh SE/30 will automatically go into interrupt mode if an error is detected at power on.*

If the UUT has video problems, the arrow may not be visible in the upper-left corner of the screen. If there is no arrow, wait about 4 seconds per megabyte of installed memory, and then press the interrupt switch.

Note: If a *MacTest SE* or *MacTest SE/30* disk was left in the UUT disk drive during power on, the *MacTest* disk may boot before you can press the interrupt switch on the UUT. If this happens, eject the *MacTest* disk, power off the UUT, and start over at step 4.

Using the AppleCAT Menus

Before you start *AppleCAT SE* or *AppleCAT SE/30*, you may use the *AppleCAT* menus to select the tests you want to run or to select other features of the diagnostic.

Note: You must make your test selections from the *AppleCAT* menus **before** starting *AppleCAT SE* or *AppleCAT SE/30*. Changes to the test selections cannot be made while the *AppleCAT* test is running. If you do not use the **Test Selections** menu, the default test selection will include the following tests:

- Logic Board
- Internal Disk Drive (Macintosh SE/30) or
- Lower Floppy Drive (Macintosh SE)

IMPORTANT: *Selecting specific tests shortens the AppleCAT SE/30 test, but selected tests cannot find all faulty modules. Only the default test selections will ensure a complete system check.*

Options Menu

The **Options** menu contains the **Test Selections** submenu. **Test Selections** allows you to select and run certain tests individually. To select a test, click in the box next to the name of the item to be tested. The box will display an X. To deselect the test, click again in the box to remove the X. When you have selected all the tests you wish, click **OK**. You will be returned to the Status window.

Note: Test Selections will remain unchanged until you change them or you reboot the *AppleCAT SE* or *AppleCAT SE/30* program.

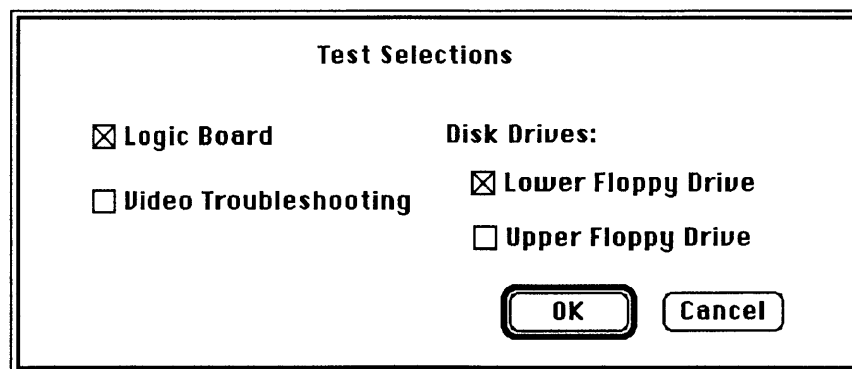

FIGURE 10

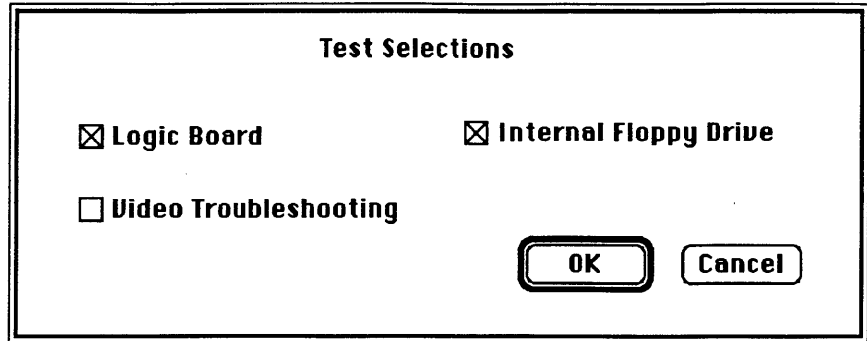

FIGURE 11

The **Test Selections** submenus for *AppleCAT SE* (Figure 10) and *AppleCAT SE/30* (Figure 11) differ slightly, but each program includes Logic Board, Video Troubleshooting, and Disk Drive tests.

1. **Logic Board:** This test verifies the correct functioning of the following circuitry on the Macintosh SE and Macintosh SE/30 logic boards:
 - ROM
 - Memory Size (RAM)
 - CPU Data Bus and Address Bus
 - Parameter RAM
 - VIA (Versatile Interface Adaptor)
 - Internal Clock
 - FPU (Floating Point Unit) (Macintosh SE/30 only)
 - Sound Chip (Macintosh SE/30 only)
 - SCC (Serial Communications Controller)
 - SCSI Bus
 - Apple Desktop Bus
 - Video RAM (Macintosh SE/30 only)

Note: Although both *AppleCAT* programs test the SCSI circuitry on the logic board, they do not test the internal SCSI hard disk. To test the hard disk, use the *Macintosh Hard Disk Drive Diagnostic* disk (see Section 3, Diagnostics, in the *SCSI Hard Disk Drives Technical Procedures*).

2. **Video Troubleshooting:** This test checks the video RAM. Be aware that video test patterns are flashed on the screen during the test—the patterns do not mean your monitor is failing.
3. **Internal Floppy Drives:** This test will verify the proper functioning of the SWIM/IWM disk controller chip, and the upper (Macintosh SE only) and lower floppy disk drives.

Note: Both the Macintosh SE and Macintosh SE/30 may have high-density disk drives installed. Testing a 1.4 MB internal drive requires swapping blank disks in the UUT. Refer to "Running the Tests," step 5, for more information.

File Menu

The **File** menu displays the following items. All are dimmed except **Stop** (during testing) and **Quit**.

- **Open...** [Command-O]
- **Close** (Dimmed unless a desk accessory is open)
- **Save Test Selections** (Option not available)
- **Stop** [Command-.]
- **Quit** [Command-Q]

1. **Stop:** Select **Stop** to end the diagnostic and return to the Status window.
2. **Quit:** Select **Quit** to exit the program and return to the desktop.

Apple Menu

Both the *AppleCAT SE* and *AppleCAT SE/30* Apple (🍏) menus contain the following desk accessories:

1. **About Diagnostic:** When selected, a dialog box displays the diagnostic name, version number, date of release, serial number, and a copy-protect statement.
2. **Control Panel:** With this option you can set preferences for items such as speaker volume, mouse tracking, whether or not AppleTalk is connected, and the desktop pattern.

The following standard desk accessories are available either from the *AppleCAT SE* or from the *AppleCAT SE/30* Apple (🍏) menu:

- **Chooser** (*AppleCAT SE/30* only)
- **Find File** (*AppleCAT SE* only)
- **Scrapbook** (*AppleCAT SE* only)
- **Alarm clock** and **Calculator** (*AppleCAT SE* only)

Help

The *AppleCAT SE/30* **Help** menu includes a **Memory Configuration** option. **Memory Configuration** shows all possible RAM SIMM configurations for your Macintosh SE/30.

The *AppleCAT SE* **Help** menu includes **SIMM Jumper Setup** and **SIMM Resistor Setup** options for the type of logic board in your Macintosh SE (see "Macintosh SE SIMM Upgrades" in Section 6, Additional Procedures). These selections show all possible RAM SIMM and corresponding jumper or resistor configurations for the Macintosh SE.

Running the Tests

After selecting the tests you wish to run using **Test Selections**, you are ready to start *AppleCAT SE* or *AppleCAT SE/30*. Click **Start** in the *AppleCAT* Status window. Please note the following:

1. The Status line at the bottom of the Status window will keep you informed of the tests being performed and their results.

Note: If the message **Could not establish communication** appears on the Status line, you may have inserted the *MacTest* disk in the UUT disk drive before powering on. If this message appears, follow the instructions given in the *AppleCAT* Status window.

2. *AppleCAT SE* and *AppleCAT SE/30* will interact with you throughout each stage of the testing. When the UUT fails a test or indicates a problem, the program will prompt you for more information or recommend a repair.

Note: When performing disk drive tests on a Macintosh SE or Macintosh SE/30 with a 1.4 MB drive, you will be required to perform setup steps (see step 5).

3. The program will ask you for information that it cannot obtain electronically. The screen will display a choice of answers. Select the most appropriate answer in each situation. After selecting a response, click **OK** to continue.

CAUTION: *Do not click the OK button until you've completed every instruction given on the screen. Failure to complete the instructions may misdirect the diagnostic.*

4. If the UUT is turned off to replace or reinstall a module:
 - a) Verify that all cables and test fixtures are reattached before powering on.
 - b) Eject all disks from the UUT, and then switch on system power.
 - c) Macintosh SE: Wait 9 to 22 seconds, depending upon how much memory is installed, and press the interrupt switch to enter interrupt mode.

Macintosh SE/30: If you do not hear the test mode chimes, wait until an arrow appears onscreen (about 4 seconds per megabyte of RAM), and then press the interrupt switch to get into the test mode.

5. *AppleCAT SE* and *AppleCAT SE/30* will also ask you to perform setup steps. When the Setup Required window appears, insert the requested disk. After inserting the disk, click **Done** to continue the test. *AppleCAT* will request the following disks:

- 800K disk (blank and write-enabled)
- High-density disk (blank and write-enabled; for FDHD drive testing only)
- Write-protected, *MacTest SE/30* disk

6. You may halt the testing by clicking **Stop** or **Pause** anytime during the tests:
 - a) Choose **Stop** to halt the testing and to return to the *AppleCAT* Status window. Choose **Start** when you wish to begin the testing sequence again from the beginning.
 - b) Choose **Pause** if you wish to discontinue testing temporarily. Choose **Continue** to resume testing from the point of interruption.

IMPORTANT: Please read all messages and instructions carefully. Do only what the *AppleCAT* program specifically instructs you to do.

Repair Confirmation Codes

If *AppleCAT SE* and *AppleCAT SE/30* find no problems, they return to the Status window. The Status line will display the message **All selected tests pass**.

If *AppleCAT SE* or *AppleCAT SE/30* detects an unidentifiable error in the Macintosh SE or Macintosh SE/30, it will issue a repair confirmation code (RCC). The RCC is an eight-digit information record that contains the diagnostic name, the diagnostic version number, the replaced module name, and the repair sequence the program followed. The RCC should be entered on the SRO form that accompanies the returned module.

AppleCAT RCCs

If *AppleCAT SE* or *AppleCAT SE/30* is unable to identify the problem with the UUT, *AppleCAT* will issue an RCC beginning with one of the following four-digit prefixes:

- **19ZZ-xxxx** for the Macintosh SE
- **4GZZ-xxxx** for the Macintosh SE/30

Helpful Suggestions

If you receive an RCC with one of the prefixes shown above, refer to Section 5, Troubleshooting, for information that can help you isolate the problem. Also keep in mind that *AppleCAT SE* and *AppleCAT SE/30* are unable to identify a system failure if any of the following is true:

- The bad module is failing intermittently.
- The system configuration changes during the test (memory is removed or added, or system power is removed).
- Selected modules are tested; only the default tests perform a complete system check.
- The replacement module itself is bad.
- You provide inaccurate input to *AppleCAT*, or set up the test station incorrectly.

□ SCSI LOOPBACK JUMPER PROCEDURE

To Determine If a Jumper Is Needed

To be used with *MacTest SE* and *AppleCAT SE*, and with *MacTest SE/30* and *AppleCAT SE/30*, the SCSI loopback card must be jumpered between Pin 25 of J1 and Pin 14 of RP1. On new SCSI loopback cards, the jumper has been etched into the printed circuit. Only cards with the old PCB artwork need the jumper procedure.

Note: This modification does not interfere with the card's use on other Macintosh or Apple II family systems, except that to work on Apple II systems, the card must be connected to a notched mouse cable. (For further information on the notched cable, refer to *Hard Disk 20SC Technical Procedures*, Section 5, "SCSI Interface Card.")

To Identify a New Card

To determine if you have a new card, which will not need to be jumpered, look at the back of the card. If the jumper is included in the artwork, there will be an **A** instead of double zeros (**00**) at the end of the part number, which is located under the words "APPLE COMPUTER" (Figure 12, #1). **These new cards do not have to be jumpered.**

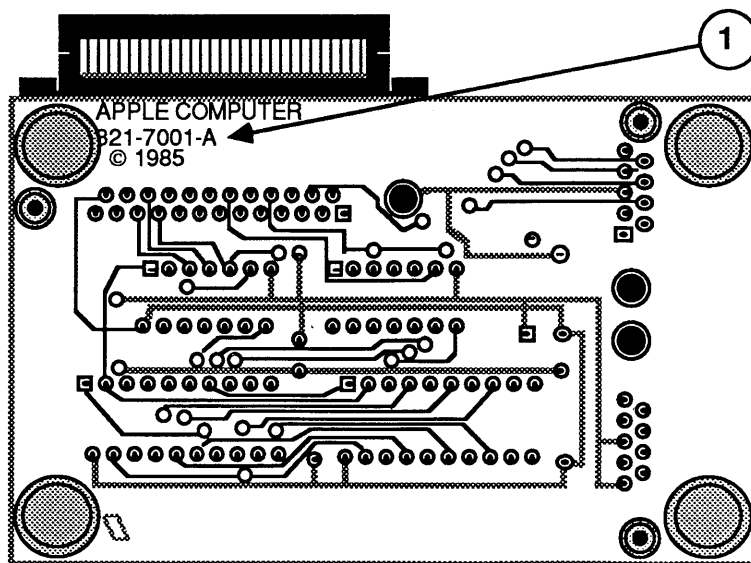

FIGURE 12

*External
Jumpers on
Old Cards*

Some cards with the **00** part number and the old artwork were modified with an external jumper during the manufacturing process. Therefore, if your card has a **00** part number, check to see if it has an external jumper from Pin 25 of J1 to Pin 14 of RP1 (Figure 13, #1). If the card has no external jumper, you must install one yourself.

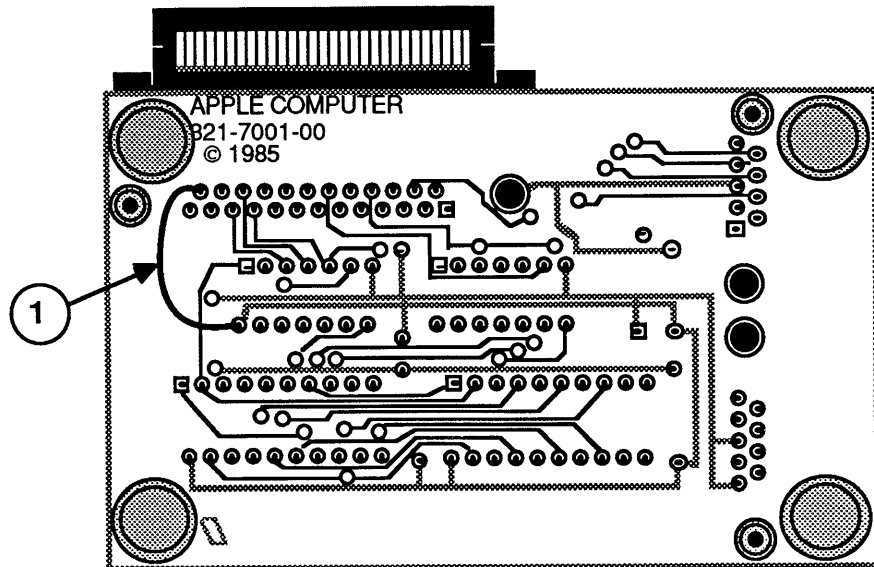

FIGURE 13

Summary

To summarize:

**If # on back
ends with:**

Do this:

A

Nothing
(Jumper is present in artwork.)

00

Check to see if external jumper
is present. If not, install jumper.

**To Install
the Jumper**

If you find that the card must be jumpered, solder a wire connection between Pin 25 of J1 and Pin 14 of RP1, as shown in Figure 13. (The pins are not numbered on the board. In the orientation shown in Figure 13, Pin 25 is the pin closest to the upper-left corner of the card, and Pin 14 is in the middle line of pins, closest to the left edge of the card.)

Macintosh SE and Macintosh SE/30

Section 5 – Troubleshooting

□ CONTENTS

5.3	Introduction
5.3	General Information
5.3	How to Use the Symptom Chart
5.3	Things to Remember
5.4	Symptom Chart
5.4	Video Problems
5.6	Peripheral Problems
5.7	Drive Problems
5.8	SCSI Problems
5.9	Miscellaneous Problems
5.10	Isolating a Faulty Macintosh SE SIMM
5.12	Battery Verification
5.12	Introduction
5.12	Materials Required
5.12	Verification Procedure



□ INTRODUCTION

General Information

There are three diagnostic tests that you may use to troubleshoot a Macintosh SE or Macintosh SE/30 system:

- *AppleCAT™ SE* or *AppleCAT™ SE/30*
- *MacTest™ SE* or *MacTest™ SE/30*
- *Macintosh Hard Disk Drive Diagnostic* (version 4.0 or higher)

Use this troubleshooting section if the diagnostics are unable to detect a failure. Read "Symptom Chart," "Isolating a Faulty Macintosh SE SIMM," and "Battery Verification" before you begin troubleshooting; **you will need this information to troubleshoot the Macintosh SE and Macintosh SE/30 effectively.** After repairing the system, run the diagnostics to verify system operation.

How to Use the Symptom Chart

Find the symptom that most nearly describes the problem, then perform the corrective actions in the order listed. If a corrective action does not fix the problem, go to the next action. **If you replace a module and find that the problem remains, reinstall the original module before you go on to the next action.**

Things to Remember

1. Read all the safety precautions before removing or installing any modules. (See Section 1, Basics.)
2. Follow all ESD precautions when troubleshooting. (See *You Oughta Know* for more information.)
3. Perform the CRT discharge procedure before removing or installing any modules. (See Section 2, Take-Apart.)
4. Use known-good software. Bad software can produce symptoms that appear to be hardware problems.
5. If a non-Apple expansion card is installed, or if an Apple expansion card is installed and the Macintosh SE or Macintosh SE/30 will not start up, remove the expansion card before troubleshooting. When the Macintosh SE or Macintosh SE/30 operates correctly without the expansion card, replace the card and test again.

□ SYMPTOM CHART

Video Problems

Solutions

- *Screen is dark; audio and drive operate*
 1. Turn brightness control clockwise.
 2. Check video cable connections.
 3. Replace analog board.
 4. Replace video board.
 5. Replace main logic board.
 6. Replace CRT.

- *Screen is bright and audio is present, but no video information is visible*
 1. Replace analog board.
 2. Replace video board.
 3. Replace main logic board.

- *Screen is completely dark and fan is not running*
 1. Replace power supply.
 2. Replace analog board.

- *A single vertical line is displayed*
 1. Replace analog board.
 2. Replace video board.
 3. Replace main logic board.
 4. Replace CRT.

- *A single horizontal line is displayed*
 1. Replace analog board.
 2. Replace video board.
 3. Replace main logic board.
 4. Replace CRT.

- *Vertical bars or stripes are displayed*
 1. Replace main logic board.
 2. Replace analog board.

- *Horizontal bars or stripes are displayed*
 1. Replace main logic board.
 2. Replace analog board.

**Video Problems
(Continued)**

Solutions

- *A white dot is displayed in center of screen*

1. Verify that the yoke cable is connected.
2. Replace analog board.
3. Replace CRT.

- *Screen jitters at top left and/or lower right*

- Replace analog board.

Peripheral Problems

Solutions

- *Cursor does not move*
 1. Check mouse connection.
 2. If mouse was connected to keyboard, connect it to a rear ADB port instead. If mouse works, keyboard should be replaced.
 3. If mouse does not work in any ADB port, replace mouse.
 4. Replace main logic board.

- *Cursor moves but clicking the mouse button has no effect*
 1. Replace mouse.
 2. Replace main logic board.

- *Cannot double-click to open an application, disk, or server*
 1. Remove any multiple system files on the hard disk.
 2. Clear parameter RAM. Hold down the <Shift><Option><Command> keys and select Control Panel from the Apple pull-down menu. Reset mouse controls.
 3. If mouse was connected to keyboard, connect it to a rear ADB port instead. If mouse works, keyboard should be replaced.
 4. If mouse does not work in any ADB port, replace mouse.
 5. Replace main logic board.

- *No response to any key on the keyboard*
 1. Check keyboard connection to ADB port.
 2. Replace keyboard cable.
 3. Replace keyboard.
 4. Replace main logic board.

- *Known-good ImageWriter, or ImageWriter II will not print*
 1. Make sure that the Chooser and the Control Panel are set correctly.
 2. Replace software with known-good.
 3. Replace printer interface cable.
 4. Replace logic board.

- *Known-good LaserWriter will not print*
 1. Make sure that the Chooser and the Control Panel are set correctly.
 2. Replace software with known-good.
 3. Refer to the *Networks* tab in the *Apple Technical Procedures*.

Drive Problems

Solutions

- *Audio and video are present, but one internal drive does not operate*
 1. Replace bad disk.
 2. Replace internal disk drive cable.
 3. Replace internal disk drive.
 4. Replace main logic board.

- *Audio and video are present, but neither internal drive operates (Macintosh SE only)*
 1. Replace bad disk.
 2. Replace main logic board.

- *External drive does not operate*
 1. Replace bad disk.
 2. Be sure the external drive is placed on the right side of the Macintosh SE or Macintosh SE/30.
 3. Replace external drive.
 4. Replace main logic board.

- *Disk ejects; display shows icon with blinking "X"*
 1. Replace disk with known-good system disk.
 2. Replace disk drive.
 3. Replace main logic board.

- *Unable to insert disk all the way*
 1. Insert opened paper clip into hole beside the drive.
 2. Power off system and hold mouse button down while powering on (to complete eject cycle).
 3. Replace disk drive.

- *Will not eject disk*
 1. Insert opened paper clip into hole beside the drive.
 2. Power off system and hold mouse button down while powering on.
 3. Replace disk drive.

- *Internal disk drive runs continuously*
 1. Replace bad disk.
 2. Replace disk drive.
 3. Replace main logic board.
 4. Replace disk drive cable.

SCSI Problems

Solutions

- *Internal or external hard disk will not operate*
 1. Verify that SCSI loopback card is not attached.
 2. Replace hard disk.
 3. Replace main logic board.
 4. Replace hard disk drive cable.

- *Works with internal or external SCSI device but will not work with both*
 1. Verify SCSI device switch setting on the external device.
 2. Replace terminator on the external device.
 3. Verify terminator is installed on the internal SCSI drive.
 4. Replace SCSI device select cable.

Miscellaneous Problems

Solutions

- *Clicking, chirping, or thumping sound*
 1. Verify analog board cable is connected at J12 on the logic board.
 2. Replace power supply.
 3. Replace analog board.
 4. Replace logic board.

- *Smoke/odor*
 1. Replace power supply.
 2. Replace analog board.

- *No video, no audio, and no drive operation*
 1. Connect power cord.
 2. Turn power on.
 3. Replace power cord.
 4. Replace power supply.
 5. Replace analog board.
 6. Replace main logic board.

- *"Sad Macintosh" icon*
 1. Replace bad diskette.
 2. Replace SIMM(s) if code matches any of those given in "Isolating a Faulty SIMM" chart.
 3. Verify that three-pin jumper on logic board is configured correctly for system RAM (Macintosh SE only). See "Macintosh SE SIMM Upgrades."
 4. Replace logic board.

- *"Sad Macintosh" icon and black vertical line are displayed; screeching sound*
 1. Verify that three-pin jumper on logic board is configured correctly for system RAM (Macintosh SE only). See "Macintosh SE SIMM Upgrades."
 2. Replace logic board.

□ ISOLATING A FAULTY MACINTOSH SE SIMM

When the Macintosh SE is powered on, the ROM runs a series of logic board tests. Failure of any of these tests results in the display of a "Sad Macintosh" icon on the screen of the Macintosh SE (only). The icon is shown with two rows of eight-digit numbers that indicate the particular fault identified by the test.

Numbers representing SIMM faults in a Macintosh SE are grouped below by first-row codes. The paired XXs in the lower rows indicate the presence of any number other than 0 in **either or both** of the two positions. Identify the SIMM socket number for the type of logic board in your Macintosh SE, and replace the faulty SIMM.

IMPORTANT: *The Macintosh SE has both **solder-type** and **jumper-type** logic boards. To correctly locate the SIMM socket with the faulty SIMM, you first must identify the type of logic board in your Macintosh SE. Refer to Additional Procedures, "SIMM Upgrades."*

Code	Solder Type	Jumper Type
0000000E 000000XX	SIMM # 1	SIMM # 3
0000000E 00XX00XX	SIMM # 1	SIMM # 3
0000000E 0000XX00	SIMM # 2	SIMM # 4
0000000E XX00XX00	SIMM # 2	SIMM # 4
=====		
00000002 000000XX	SIMM # 1	SIMM # 3
00000002 00XX00XX	SIMM # 1	SIMM # 3
00000002 0000XX00	SIMM # 2	SIMM # 4
00000002 XX00XX00	SIMM # 2	SIMM # 4

Code	Solder Type	Jumper Type
00000003 000000XX	SIMM # 1	SIMM # 3
00000003 00XX00XX	SIMM # 1	SIMM # 3
00000003 0000XX00	SIMM # 2	SIMM # 4
00000003 XX00XX00	SIMM # 2	SIMM # 4

=====

00000004 000000XX	SIMM # 3	SIMM # 1
00000004 00XX00XX	SIMM # 3	SIMM # 1
00000004 0000XX00	SIMM # 4	SIMM # 2
00000004 XX00XX00	SIMM # 4	SIMM # 2

=====

00000005 000000XX	SIMM # 3	SIMM # 1
00000005 00XX00XX	SIMM # 3	SIMM # 1
00000005 0000XX00	SIMM # 4	SIMM # 2
00000005 XX00XX00	SIMM # 4	SIMM # 2

Note: With some SIMM faults, the "Sad Macintosh" display may not be entirely readable. In such cases, press the reset/interrupt switch. The code may flash very quickly before the machine attempts to reboot. An unreadable code often indicates a fault with the SIMM at position 3 or 4; so if you cannot find a way to read the code, try replacing these two SIMMs, one at a time.

□ BATTERY VERIFICATION

Introduction

The Macintosh SE and Macintosh SE/30 logic boards each have a long-life lithium battery. Use the following procedure to check battery operation. If the battery falls below specifications, it must be replaced. Refer to Additional Procedures for replacement information.

WARNING: *Lithium batteries, the type used in the Macintosh SE and Macintosh SE/30, have some potential for explosion if improperly handled. Follow the procedure below exactly as written.*

Materials Required

Voltmeter

Verification Procedure

To check the lithium battery with a voltmeter:

1. Be sure the power is off. Then remove the logic board from the Macintosh SE or Macintosh SE/30.
2. Locate the lithium battery. Figure 1, #1 shows the location of the battery on a Macintosh SE logic board; Figure 2, #1 shows the battery location on a Macintosh SE/30 logic board.

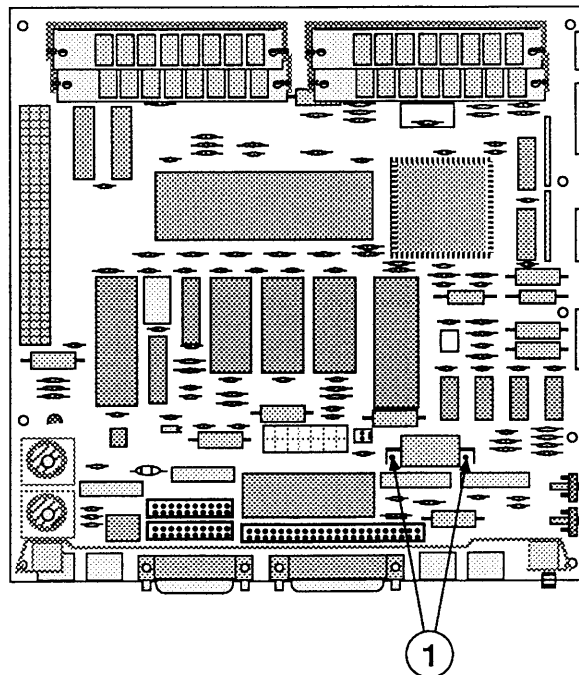

FIGURE 1

3. Set the voltmeter range to measure 10 volts DC.

Note: The battery in the Macintosh SE/30, and in all Macintosh SEs sold after August 1989, is installed in a plastic battery holder. It may be necessary to remove the battery holder cover (Macintosh SE/30 only) (Figure 2, #1) and pull out the battery by hand to measure battery voltage.

4. Touch and hold the positive probe of the voltmeter to the positive side of the battery.
5. Touch and hold the ground probe of the voltmeter to the negative side of the battery.
6. The reading for a good battery should be above 2.8 volts.

If the battery voltage is below 2.8 volts, replace the battery. To replace the Macintosh SE battery, refer to Section 6, Additional Procedures.

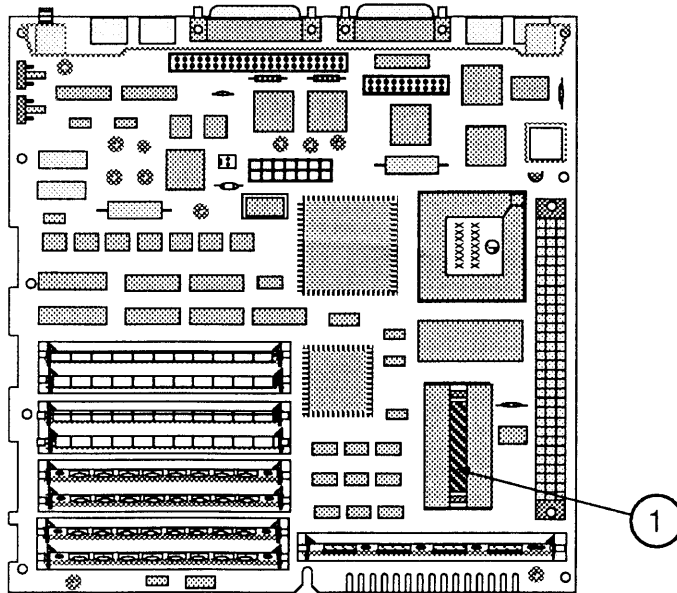

FIGURE 2

(

(

(

Macintosh SE and Macintosh SE/30

Section 6 – Additional Procedures

□ CONTENTS

6.3	Battery Replacement
6.3	Introduction
6.4	Battery Identification
6.5	Replacing Soldered Batteries (SE only)
6.7	Replacing Batteries in Battery Holders
6.8	SIMM Identification
6.8	Speed
6.8	1 MB SIMMs
6.9	256K SIMMs
6.10	Macintosh SE SIMM Upgrades
6.10	RAM Configurations
6.11	SIMM Arrangements
6.12	Logic Board Identification
6.14	Solder-Type Logic Board
6.15	Solder-Type Upgrades
6.17	Jumper-Type Logic Board
6.18	Jumper-Type Upgrades
6.20	Macintosh SE/30 SIMM Upgrades
6.20	RAM Configurations
6.20	SIMM Arrangements
6.21	SIMM Upgrades
6.24	Macintosh SE Chassis Tab Modification
6.24	Introduction
6.24	Modification Procedure
6.25	Chassis Assembly
6.25	Introduction
6.25	Assembly Procedure
6.26	Macintosh SE/30 Logic Board Upgrade
6.26	Introduction
6.26	Installation
6.29	FDHD Upgrade for the Macintosh SE
6.29	Introduction
6.29	Materials Required
6.29	Upgrade Procedure



□ BATTERY REPLACEMENT

Introduction

Lithium thionyl chloride batteries, the type used in the Macintosh SE and Macintosh SE/30, have some potential for explosion if improperly handled. The following precautions should be taken when storing, handling, or disposing of lithium batteries.

- Lithium batteries should be stored in a designated, well-marked area with limited access.
- Apple's lithium batteries are sealed in individual zip-lock wrappers. Upon receipt, the batteries should be inspected for integrity of their wrappers, and should be stored in the same packaging in which they were received.
- Lithium batteries cannot be recharged. Do not attempt to recharge the battery. Doing so may cause the battery to overheat or explode.
- Do not allow the leads or terminals to short-circuit. A short-circuited battery may overheat or explode.
- Replace the battery with the correct Apple replacement battery only. Using an incorrect battery or a non-Apple battery may cause the battery to overheat or explode.
- When installing the battery, ensure the correct polarity. The polarity markings on the battery must match those on the battery holder or circuit board. Failure to observe correct polarity may cause the battery to overheat or explode.
- If the battery holder was provided with a cover, be sure to replace the cover.
- If the dead battery has leads, remove them before disposing of the battery.
- Do not dispose of the battery in a fire or incinerator. Doing so may cause the battery to explode.
- In addition to its explosive potential, lithium is water reactive and must be disposed of as a hazardous waste, as follows:

After removing a "dead" battery from the board, clip off its lead wires (necessary only for batteries that have been unsoldered from a Macintosh SE logic board), and place the battery into the zip-lock wrapper and packaging from which the replacement battery was taken. Mark the battery *DEAD* and return it to Apple, where it will be disposed of following EPA guidelines. **Exception:** If the battery is physically damaged (for example, it's leaking), do not return it to Apple; dispose of the battery locally according to your local ordinances.

The long-life lithium battery in the Macintosh SE and Macintosh SE/30 should serve many years. Refer to Section 5, Troubleshooting, to check the condition of the battery. If the battery should fail for some reason, replace it according to the following procedure.

Battery Identification

The Macintosh SE and Macintosh SE/30 contain a single long-life lithium battery. In the Macintosh SE, this battery is either soldered to the logic board or installed in a plastic battery holder. In the Macintosh SE/30, the battery is always installed in a battery holder.

If a soldered battery fails, replace it using the "Replacing Soldered Batteries (SE only)" procedure. Replace all other batteries using the "Replacing Batteries in Battery Holders" procedure.

Materials Required

Grounded workbench and wriststrap

CAUTION: Use ESD precautions before removing or replacing the battery. Failure to do so may result in logic board failure.

Replacing Soldered Batteries (SE only)

To replace a bad battery that has been soldered to a Macintosh SE logic board:

1. Remove the cover and discharge the CRT.

WARNING: *Never put on your grounding wriststrap until after the CRT has been discharged.*

2. Move the Macintosh SE onto a soft, grounded workbench pad and put on your grounding wriststrap.
3. Remove the main logic board and place it on the grounded workbench pad.

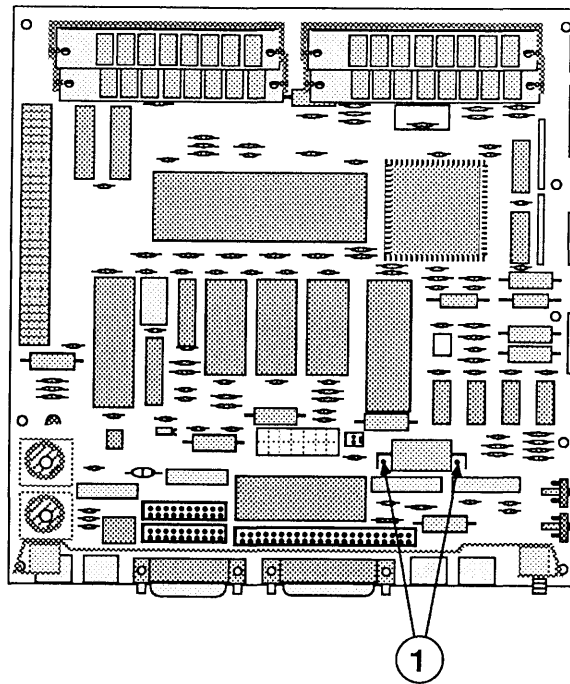

FIGURE 1

4. Using wire clippers, cut the leads (Figure 1, #1) at both ends of the battery to free it from the main logic board. Cut the leads as close to the logic board as you can without touching the board with the clippers.

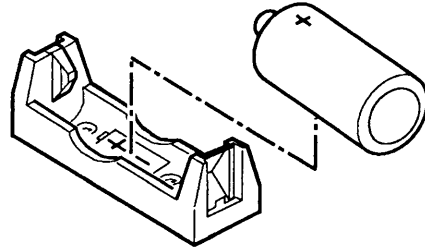

FIGURE 2

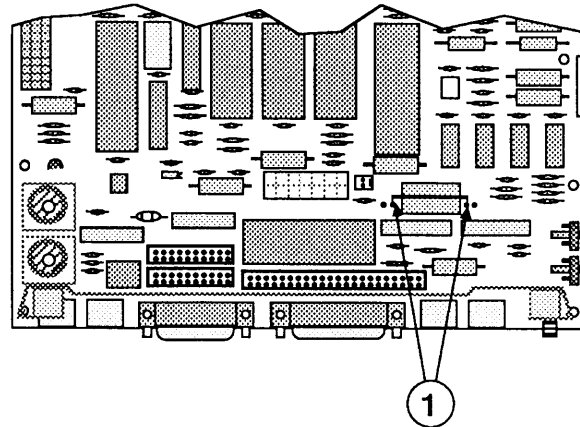

FIGURE 3

5. Orient the new battery so that the end marked "+" matches the "+" on the main logic board (Figure 2). Insert the battery leads into the extra set of mounting holes (Figure 3, #1) on the logic board (just inside the original mounting holes). Make sure the leads go all the way through the logic board to the other side.
 6. Holding the battery in place, turn the logic board over and touch a soldering iron to the two new battery leads protruding through the inner mounting holes.
- Note:** It is not necessary to desolder the remains of the old leads from the outer mounting holes.
7. Replace the main logic board and the cover.
 8. Trim the leads of the old battery, package and label it as directed in the introduction to this procedure, and return the battery to Apple for proper disposal.

Replacing Batteries in Battery Holders

To replace a bad battery that has been installed in a plastic battery holder on either a Macintosh SE or Macintosh SE/30 logic board:

1. Remove the cover and discharge the CRT.

WARNING: *Never put on your grounding wriststrap until after the CRT has been discharged.*

2. Move the computer onto a soft, grounded workbench pad and put on your grounding wriststrap.
3. Remove the main logic board and place it on the grounded workbench pad.
4. Remove the plastic cover (Macintosh SE/30 only) (Figure 4, #1) and pull the battery out of the battery holder (Figure 4, #2).
5. Orient the new battery so that the end marked "+" matches the "+" on the main logic board (Figure 2). Insert the battery in the battery holder (Figure 4, #2) and (if necessary) replace the plastic cover (Figure 4, #1).
6. Replace the main logic board and the cover.
7. Package and label the old battery as directed in the introduction to this procedure, and return the battery to Apple for proper disposal.

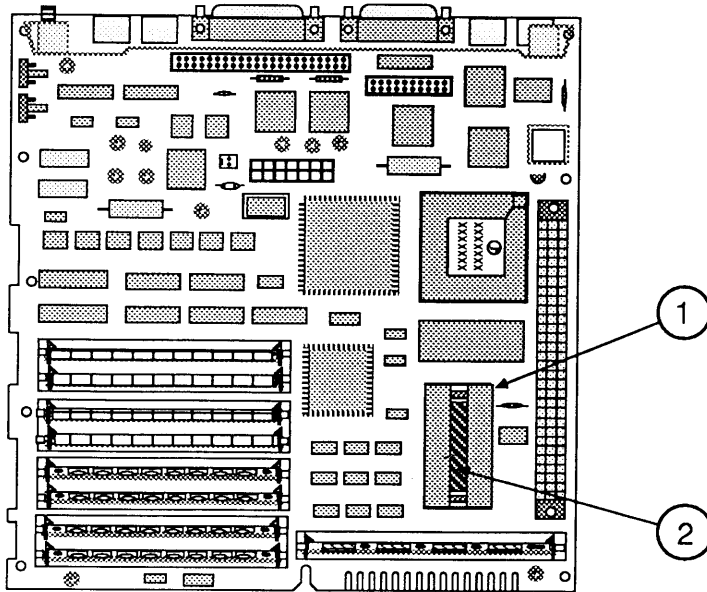

FIGURE 4

□ SIMM IDENTIFICATION

Single In-line Memory Modules (SIMMs) for the Macintosh SE and Macintosh SE/30 are available with two sizes of RAM—256K and 1 MB—and come in several configurations that can be used interchangeably.

CAUTION: SIMMs are very susceptible to damage from ESD and skin acid. Handle only by the edges!

Speed

You must use 150 ns (or faster) SIMMs on the Macintosh SE and 120 ns (or faster) SIMMs on the Macintosh SE/30. SIMMs with a slower rating than those specified will cause serious timing problems. The RAM speed is usually indicated by the -xx number after the manufacturer's part number. For example, -15 indicates 150 ns SIMMs and -12 indicates 120 ns SIMMs.

1 MB SIMMs

The 1 MB SIMMs come in two configurations:

- 1 MB SOJ SIMM (Figure 5, #1)
The 1 MB SOJ (Single Out-line J-Lead) SIMM contains eight surface-mounted ICs. Each IC has ten pins (or legs) on each of two sides.
- 1 MB DIP SIMM (Figure 5, #2)
The 1 MB DIP (Dual In-line Package) SIMM contains eight ICs mounted through the printed circuit board. Each IC has nine pins (or legs) on each of two sides.

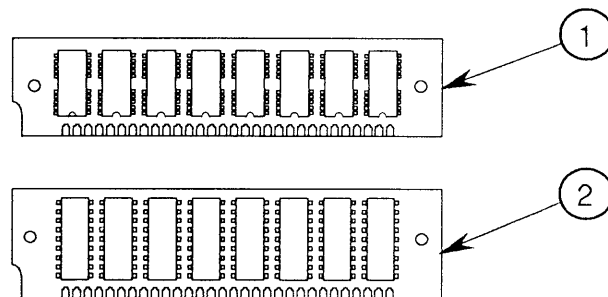

FIGURE 5

256K SIMMs

The 256K SIMMs come in several configurations:

- 256K SOJ SIMM (Figure 6, #1)
The 256K SOJ (Single Out-line J-Lead) SIMM contains two surface-mounted ICs. Each IC has ten pins (or legs) on each of two sides.
- 256K DIP SIMM (Figure 6, #2)
The 256K DIP (Dual In-line Package) SIMM contains two ICs mounted through the printed circuit board. Each IC has ten pins (or legs) on each of two sides.
- 256K PLCC SIMM (Figure 6, #3)
The 256K PLCC (Plastic Leaded Chip Carrier) SIMM contains eight surface-mounted ICs. Each IC has five pins (or legs) on each of two sides and four pins on each of the other two sides.
- 256K DIP SIMM (Figure 6, #4)
This DIP SIMM contains eight ICs. Each IC has eight pins on each of two sides.

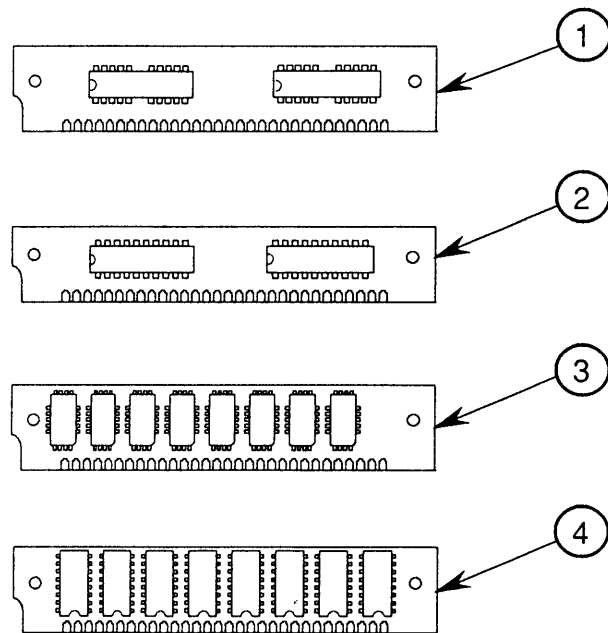

FIGURE 6

□ MACINTOSH SE SIMM UPGRADES

RAM memory for the Macintosh SE and Macintosh SE/30 is installed on Single In-line Memory Modules (SIMMs). When performing SIMM upgrades, keep in mind that the Macintosh SE and Macintosh SE/30 contain completely different CPUs, and the upgrade procedures are different. If you are upgrading a Macintosh SE/30, refer to "Macintosh SE/30 SIMM Upgrades" later in this section. Steps for upgrading a Macintosh SE follow.

IMPORTANT: *When performing SIMM upgrades, it is important to remember that there are two configurations of the Macintosh SE logic board, and that the upgrade procedure is different for each configuration. See "Logic Board Identification" for more information.*

Note: When removing SIMMs from the logic board, use the SIMM removal tool. Instructions are in *You Oughta Know*.

RAM Configurations

The Macintosh SE can be configured with 1 MB, 2 MB, 2.5 MB, or 4 MB of RAM installed on the logic board. Because there are two different versions of the Macintosh SE logic board, and several configurations of the 256K and 1 MB SIMMs, system expansion must follow strict guidelines. The memory upgrade guidelines that follow will enable you to identify and modify your version of the Macintosh SE logic board and install SIMMs correctly on the board.

SIMM Arrangements

The Macintosh SE logic board has four SIMM sockets (Figure 7, #1), labeled 1, 2, 3, and 4. These sockets are arranged in two rows: SIMM 1 and SIMM 2 are paired together in one row, and SIMM 3 and SIMM 4 together form the other row. Rows can have either two 256K SIMMS or two 1M SIMMS installed.

Note: The oversized 256K and 1M DIP SIMMS should be installed in SIMM sockets 3 and 4 only. DIP SIMMS installed in SIMM sockets 1 and 2 may interfere with the installation of cards in the expansion connector (Figure 7, #2).

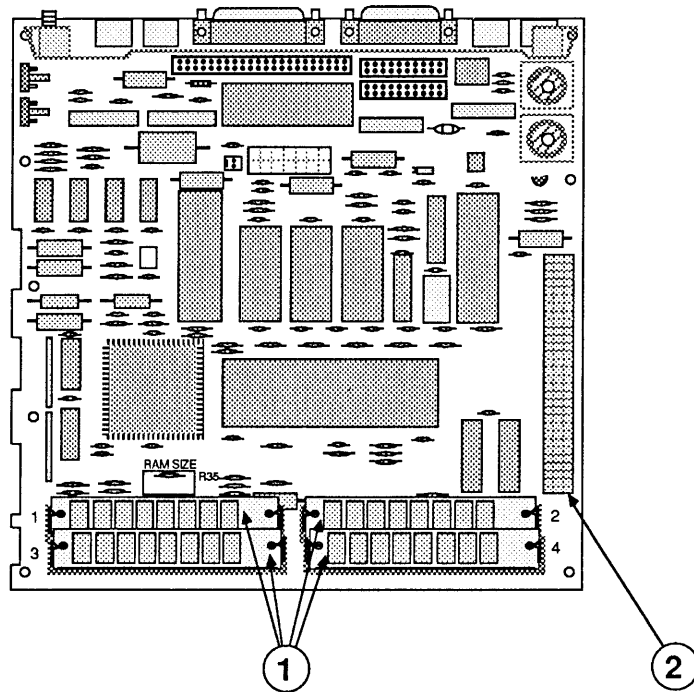

FIGURE 7

Logic Board Identification

Because the upgrade procedure is different for the solder-type and jumper-type versions of the Macintosh SE logic board, you must first identify the type of logic board you are upgrading:

1. **Solder-type logic board**—Locate the area on the logic board identified by Figure 8, #1. On one version of the Macintosh SE logic board the area is labeled "RAM SIZE," and may have a R35 or R36 resistor (Figure 8, #2) soldered to the logic board. Refer to "Macintosh SE Solder-Type Logic Boards" for more information.

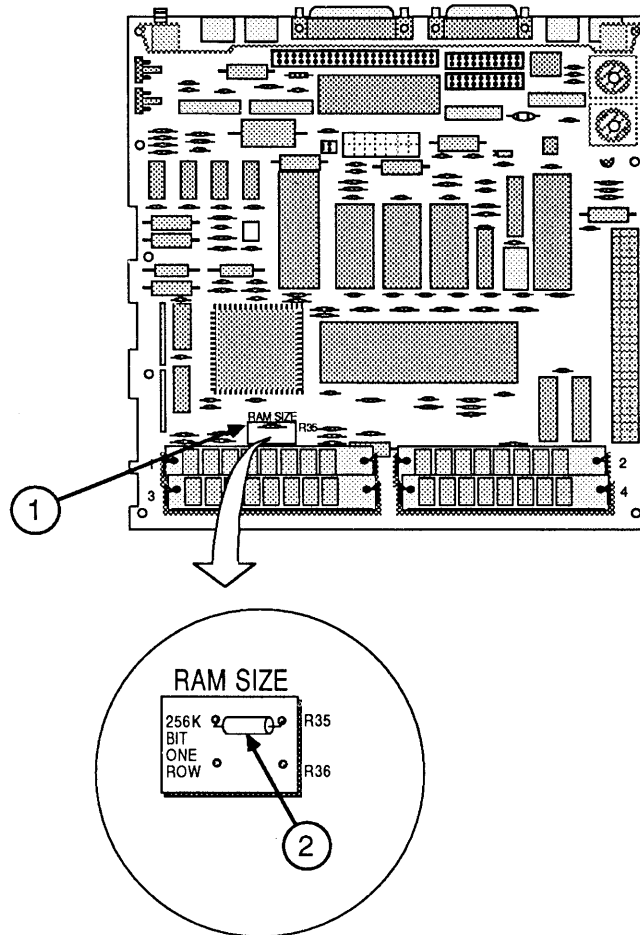

FIGURE 8

2. **Jumper-type logic board**—The other version of the Macintosh SE logic board has a three-pin jumper block at the area on the logic board identified by Figure 9, #1. The jumper block is labelled "2/4M 1M" on the logic board. Refer to "Jumper-Type Logic Boards" for more information on this version of the Macintosh SE logic board.

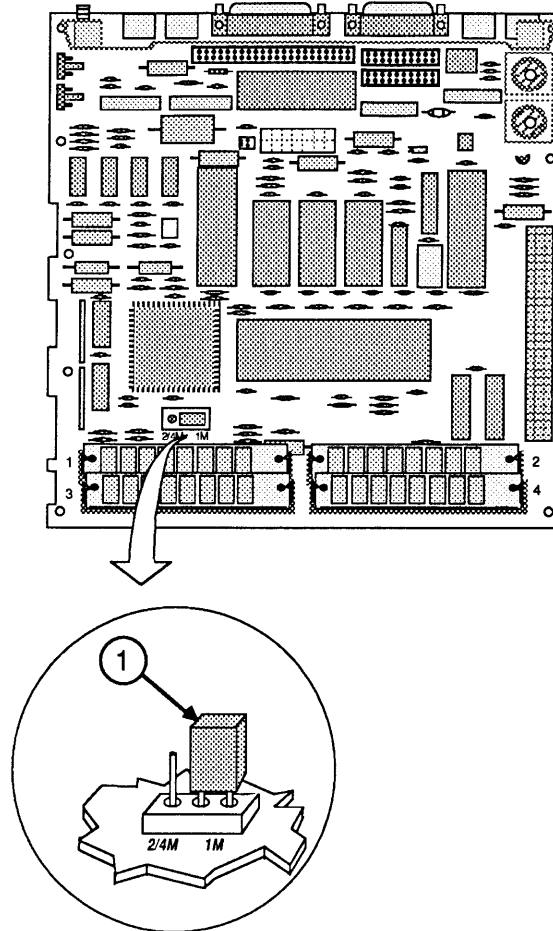

FIGURE 9

Solder-Type Logic Board

Upgrading the system RAM may require making changes to the logic board. Locate the area of the logic board labeled RAM SIZE. The location of two resistors in this area, or the absence of these resistors, tells the Macintosh SE important information about what kind of SIMMs and how many are installed on the logic board.

1-Megabyte Configuration

The standard 1-megabyte RAM configuration consists of four 256K SIMMs installed in both rows on the Macintosh SE logic board. The presence of resistor R35 (marked "256K BIT")—soldered to the logic board as shown in Figure 10, #1—tells your computer that 256K SIMMs are installed in both rows on the logic board. You will need to cut or remove resistor R35 to upgrade computer RAM; computers configured with 1 MB of RAM can be upgraded to 2.5 MB and 4 MB.

2-Megabyte Configuration

The standard 2 MB configuration has two 1 MB SIMMs installed in the first row (SIMM sockets 1 and 2) on the logic board. The presence of resistor R36 (marked "ONE ROW")—soldered to the logic board as shown in Figure 10, #2—tells your computer that only one row of 1 MB SIMMs is installed on the logic board. If you are adding a second row of SIMMS to the logic board, resistor R36 must be cut or removed.

— 2.5-Megabyte Configuration

A Macintosh SE can be configured with 2.5 MB of RAM by installing two 1 MB SIMMs in the first row (SIMM sockets 1 and 2), and two 256K SIMMs in the second row (SIMM sockets 3 and 4) on the logic board. Both the R35 and R36 resistors must be cut or removed to upgrade a Macintosh SE to 2.5 MB of RAM.

4-Megabyte Configuration

A Macintosh SE can be configured with 4 MB of RAM by installing a 1 MB SIMM in each of the four SIMM sockets on the logic board. The R35 and R36 resistors must be cut or removed to upgrade to 4 MB.

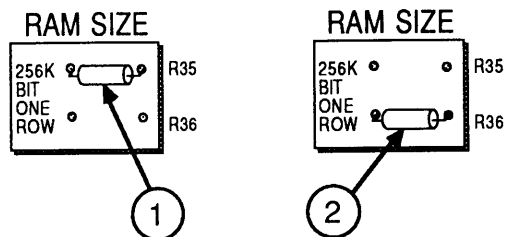

FIGURE 10

Solder-Type Upgrades

Follow the procedure below to expand a 1-megabyte Macintosh SE (with the solder-type logic board) to 2.5 or 4 megabytes, or to expand the 2 MB configuration to 2.5 or 4 megabytes. (For detailed take-apart, CRT discharge, and module installation instructions, see Section 2, Take-Apart.)

1. Remove the cover and discharge the CRT.
2. Move the Macintosh SE onto a soft, grounded workbench pad, and put on your grounding wriststrap. (Never put on a grounding wriststrap until after the CRT has been discharged.)
3. Remove the main logic board and place it on the grounded workbench pad.
4. If you are adding memory to a computer with 1 megabyte of RAM, perform the following steps:
 - a) Locate resistor R35, marked "256K BIT" (Figure 10, #1). Using small diagonal cutters, clip the resistor off the board and discard it. (You do not need to desolder the leads from the board.)
 - b) Perform the steps that follow for the upgrade you are making:

Note: When removing SIMMs, use the SIMM removal tool. See *You Oughta Know* for SIMM tool instructions.

To 2.5 megabytes: Remove the two 256K SIMMS from positions 1 and 2, and install two 1 MB SIMMs in those positions. Leave the two 256K SIMMs in positions 3 and 4. Place the removed 256K SIMMs in an antistatic bag, and return them to the customer.

To 4 megabytes: Remove the four 256K SIMMS, and install four 1 MB SIMMs. Place the removed 256K SIMMs in an antistatic bag, and return them to the customer.

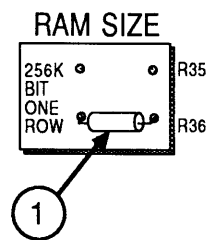

FIGURE 11

5. If you are upgrading a 2-megabyte computer, perform the following steps:
 - a) Locate resistor R36, marked "ONE ROW" (Figure 11, #1). Using small diagonal cutters, clip the resistor off the board and discard it. (You do not need to desolder the leads from the board.)
 - b) Perform the steps that follow for the upgrade you are making:

To 2.5 megabytes: Add two 256K SIMMS to positions 3 and 4.

To 4 megabytes: Add two 1 MB SIMMs to positions 3 and 4.

6. Replace the main logic board, and replace the cover.

Jumper-Type Logic Board

Changes to the logic board must be made for some RAM configurations. Locate the three-pin jumper block on the logic board (Figure 12). The presence or position of a jumper between terminals on the jumper block tells the Macintosh what kind of SIMMs, and how many rows of SIMMS, are installed on the logic board.

1-Megabyte Configuration

The standard 1-megabyte RAM configuration consists of four 256K SIMMs installed in both rows on the Macintosh SE logic board. The jumper that is installed on the jumper block terminals labeled "1M" (Figure 12, #1) tells the Macintosh that you have 1 MB of RAM installed on the logic board. You will need to remove this jumper to upgrade computer RAM; computers configured with 1 MB of RAM can be upgraded to 2.5 MB and 4 MB.

2-Megabyte Configuration

The standard 2 MB configuration has two 1 MB SIMMs installed in the second row (SIMM sockets 3 and 4) on the logic board. The jumper that is installed on the jumper block terminals labeled "2/4M" (Figure 12, #2) tells the Macintosh SE that you have 2 MB of RAM installed on the logic board. If you are adding a second row of SIMMS to the logic board, you must remove this jumper.

2.5-Megabyte Configuration

A Macintosh SE configured with 2.5 MB of RAM has two 1 MB SIMMs installed in the second row (SIMM sockets 3 and 4), and two 256K SIMMs installed in the first row (SIMM sockets 1 and 2) on the logic board. The jumper must be completely removed to upgrade a Macintosh SE to 2.5 MB (Figure 12, #3).

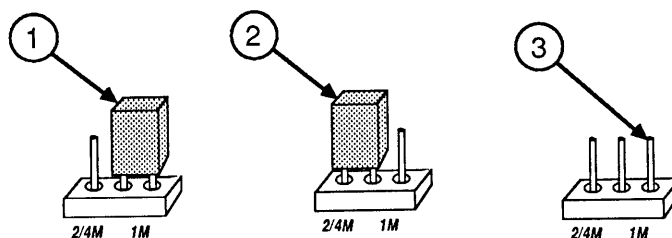

FIGURE 12

4-Megabyte Configuration

A Macintosh SE configured with 4 MB of RAM has a 1 MB SIMM installed in each of the four SIMM sockets on the logic board. Again, the jumper must be completely removed (Figure 13, #1).

Jumper-Type Upgrades

Follow the procedure below to expand a 1 MB Macintosh SE (with the jumper-type logic board) to 2.5 or 4 megabytes, or to expand the 2 MB configuration to 2.5 or 4 megabytes. (For detailed take-apart, CRT discharge, and module installation instructions, see Section 2, Take-Apart.)

Materials Required

Needlenose pliers

Upgrade Procedure

1. Remove the cover and discharge the CRT.
2. Move the Macintosh SE onto a soft, grounded workbench pad and put on your grounding wriststrap. (Never do this until after discharging the CRT.)
3. Remove the main logic board and place it on the grounded workbench pad.

IMPORTANT: *The Macintosh SE will not recognize that it has been upgraded to 2.5 or 4 megabytes unless the jumper is removed in step 4 or 5. When upgrading to 2.5 or 4 megabytes, be sure to completely remove the logic board jumper. Also note that the AppleCAT SE diagnostic cannot detect this configuration problem.*

4. If you are adding memory to a Macintosh SE with 1 megabyte of RAM, perform the following steps:
 - a) Locate the jumper (Figure 13, #2). Using pliers, completely remove the jumper from the three-pin jumper block.

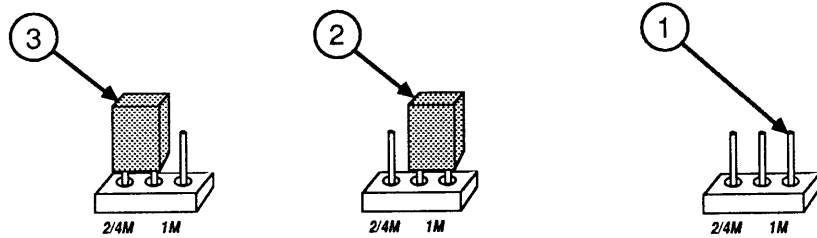

FIGURE 13

b) Perform the steps that follow for your upgrade:

Note: When removing SIMMs, use the SIMM removal tool. See *You Oughta Know* for SIMM tool instructions.

To 2.5 megabytes: Remove the two 256K SIMMS from positions 3 and 4, and install two 1 MB SIMMs in those positions. Leave the two 256K SIMMs in positions 1 and 2. Place the removed 256K SIMMs in an antistatic bag, and return them to the customer.

To 4 megabytes: Remove the four 256K SIMMS, and install four 1 MB SIMMs. Place the removed 256K SIMMs in an antistatic bag, and return them to the customer.

5. If you are upgrading a 2-megabyte Macintosh SE, perform the following steps:

a) Locate the jumper (Figure 13, #3). Using pliers, completely remove the jumper from the three-pin jumper block.

b) Perform the steps that follow for your upgrade:

To 2.5 megabytes: Add two 256K SIMMS to SIMM sockets 1 and 2.

To 4 megabytes: Add two 1 MB SIMMs to SIMM sockets 1 and 2.

6. Replace the main logic board, and replace the cover.

□ MACINTOSH SE/30 SIMM UPGRADES

RAM Configurations

The Macintosh SE/30 can be configured with 1 MB, 2 MB, 4 MB, 5 MB, or 8 MB of RAM memory. The redesigned Macintosh SE/30 logic board has 8 SIMM sockets, and can use several types of 256K and 1 MB, 120-nanosecond SIMMs.

SIMM Arrangements

The 8 SIMM sockets on the Macintosh SE/30 logic board are arranged in two banks. Bank A (Figure 14, #1) includes the four SIMM sockets nearest the edge of the board (labeled "SIM1" and "SIM2" on the logic board). Bank B (Figure 14, #2) includes the four innermost SIMM sockets (labelled "SIM3" and "SIM4" on the logic board).

There are four guidelines to keep in mind whenever you upgrade a Macintosh SE/30:

- Each bank must either be filled with four like SIMMs (four 256K SIMMS, or four 1 MB SIMMS) or left empty.
- Bank A must be used (filled with SIMMs) first.
- If SIMMs of different memory capacity are used, the higher capacity (1 MB) SIMMs should always fill Bank A, with the lower capacity (256K) SIMMs in Bank B.
- The oversized 256K and 1 MB DIP SIMMs should be installed in Bank A only.

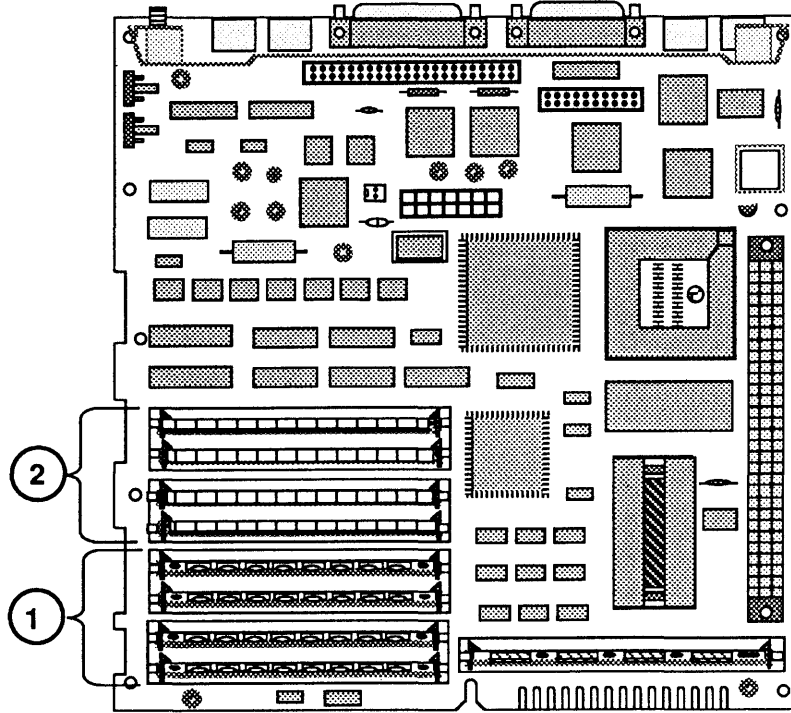

FIGURE 14

**SIMM
Upgrades**

You can upgrade a standard Macintosh SE/30 (1 or 4 megabytes of RAM) to one of these configurations:

<u>RAM</u>	<u>Bank A</u>	<u>Bank B</u>
2 MB	Four 256K SIMMs	Four 256K SIMMs
5 MB	Four 1 MB SIMMs	Four 256K SIMMs
8 MB	Four 1 MB SIMMs	Four 1 MB SIMMs

To perform this procedure, find the RAM upgrade you are making, and follow steps that are appropriate for the current RAM configuration of your Macintosh SE/30. (For detailed take-apart, CRT discharge, and module installation instructions, see Section 2, Take-Apart.)

Note: Whenever you are removing SIMMs, use the SIMM removal tool. See *You Oughta Know* for SIMM tool instructions.

**2 MB
Upgrade**

1. Remove the cover and discharge the CRT.
2. Move the Macintosh SE/30 onto a soft, grounded workbench pad, and put on your grounding wriststrap—but never put on the grounding wriststrap until **after** you have discharged the CRT.
3. Remove the main logic board and place it on the grounded workbench pad.

CAUTION: *Oversized 256K DIP SIMMs should not be installed in Bank B.*

4. Install four 256K SIMMs in Bank B (Figure 15, #2).
5. Replace the main logic board, and replace the cover.

**5 MB
Upgrade**

1. Remove the cover and discharge the CRT.
2. Move the Macintosh SE/30 onto a soft, grounded workbench pad, and put on your grounding wriststrap—but never put on the grounding wriststrap until **after** you have discharged the CRT.

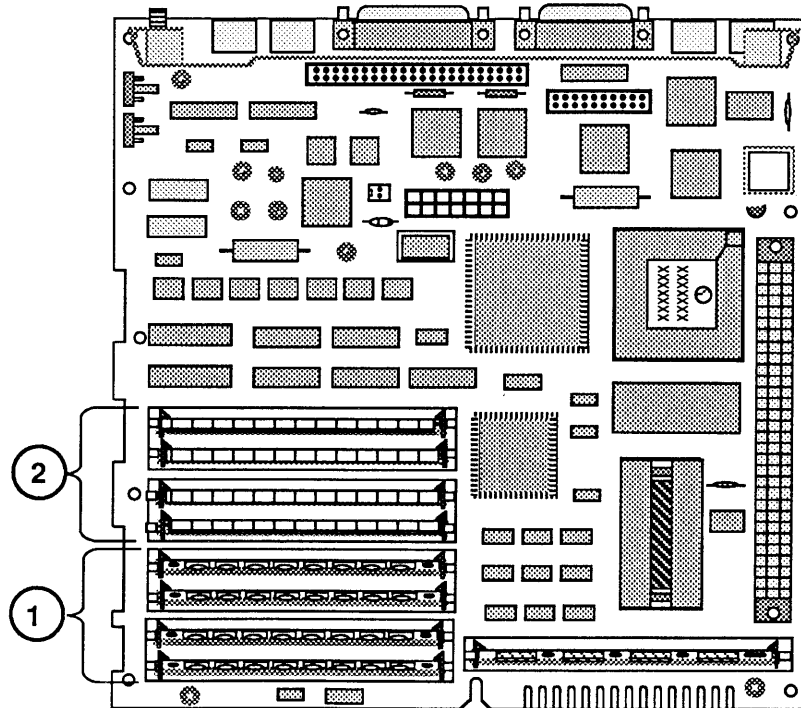

FIGURE 15

3. Remove the main logic board and place it on the grounded workbench pad.

CAUTION: *Oversized 256K DIP SIMMs should not be installed in Bank B.*

4. If the Macintosh SE/30 has **1 megabyte of RAM**:
 - a) Remove four 256K SIMMs from Bank A (Figure 15, #1) and install them in Bank B (Figure 15, #2).
 - b) Install four 1 MB SIMMs in Bank A.
5. If the Macintosh SE/30 has **4 megabytes of RAM**, install four 256K SIMMs in Bank B (Figure 15, #2).
6. Replace the main logic board, and replace the cover.

**8 MB
Upgrade**

1. Remove the cover and discharge the CRT.
2. Move the Macintosh SE/30 onto a soft, grounded workbench pad, and put on your grounding wriststrap—but never put on the grounding wriststrap until **after** you have discharged the CRT.
3. Remove the main logic board and place it on the grounded workbench pad.

CAUTION: *Oversized 1 MB DIP SIMMs should not be installed in Bank B.*

4. If the Macintosh SE/30 has **1 megabyte of RAM**:
 - a) Remove the four 256K SIMMs from Bank A (Figure 15, #1), place them in an antistatic bag, and return them to the customer.
 - b) Install eight 1 MB SIMMs in Banks A and B.
5. If the Macintosh SE/30 has **4 megabytes of RAM**, install four 1 MB SIMMs in Bank B (Figure 15, #2). Leave the other four 1 MB SIMMs in Bank A.
6. Replace the main logic board, and replace the cover.

□ MACINTOSH SE CHASSIS TAB MODIFICATION

Introduction

Some chassis configurations for the Macintosh SE have left side panels (side opposite the analog board) with protruding tabs. The protruding tab nearest the back of the chassis may interfere with the installation of some third-party cards, or it may interfere with the routing of some third-party card cables. If you encounter this problem when installing third-party cards or cables, perform the following procedure.

Materials Required

Pliers

Modification Procedure

Although chassis configurations may differ slightly, the procedure for modifying chassis tabs is the same.

CAUTION: *When bending chassis tabs, make sure the pliers do not slip off the chassis and damage nearby components.*

To modify a Macintosh SE chassis, bend the tab (Figure 16, #1) with a pair of pliers until the tab is flush with the chassis side panel (Figure 16, #2).

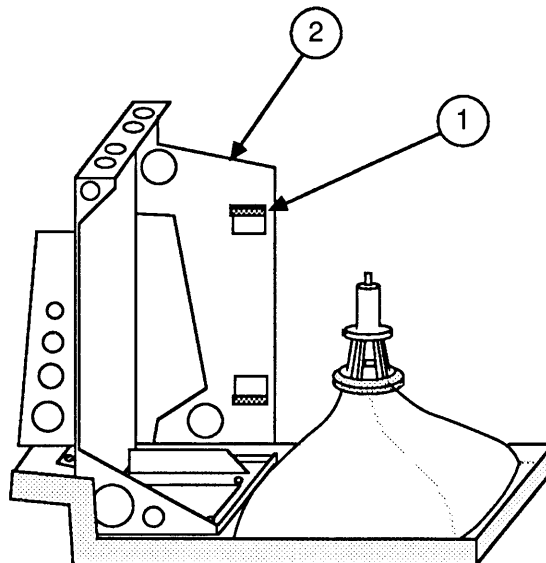

FIGURE 16

□ CHASSIS ASSEMBLY

Introduction

The Macintosh SE and Macintosh SE/30 have a redesigned chassis assembly that consists of two pieces—a chassis, and a separate bracket. The bracket will need to be assembled on the chassis whenever you install the new chassis assembly. The new chassis assembly must be installed if you are upgrading a Macintosh SE with an older chassis to a Macintosh SE/30.

Materials Required

Chassis
Bracket
3 screws
Phillips screwdriver

Assembly Procedure

Position the bracket (Figure 17, #1) on the chassis as shown in Figure 17. Align the three screw holes in the bracket and chassis, and install three screws (Figure 17, #2).

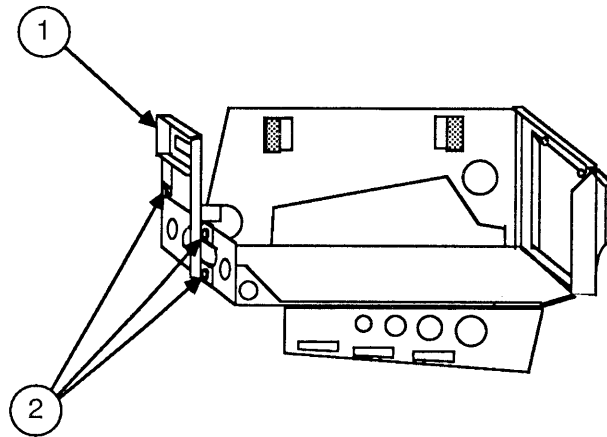

FIGURE 17

□ MACINTOSH SE/30 LOGIC BOARD UPGRADE

Introduction

A Macintosh SE/30 Logic Board Upgrade Kit is available to Macintosh SE owners. The Macintosh SE/30 logic board includes a 68030 microprocessor with built-in paged memory management, a 68882 math coprocessor, a new ROM SIMM, and a SWIM chip capable of controlling the 1.4 MB FDHD disk drive.

The upgrade kit includes, in addition to the new logic board: a new bezel (the Macintosh SE/30 supports only one internal drive), a ferrite bead and tie-wrap for EMI protection, a new chassis and bracket, a new RFI shroud, and a return sheet to be filled out when returning the original logic board to Apple.

Four identical RAM SIMMs must be installed in each bank of SIMM slots on the Macintosh SE/30 logic board (or the entire bank must be left empty). Therefore, customers whose Macintosh SE systems have 2 MB or 2.5 MB of RAM will need to obtain additional RAM SIMMs to use the upgraded logic board.

Refer to Section 2, Take-Apart, for referenced procedures.

Materials Required

Macintosh SE/30 Logic Board Upgrade Kit
Grounded workbench pad and wriststrap
Medium Phillips screwdriver
Torx screwdriver

Installation

1. Remove the cover and discharge the CRT.
2. Place the Macintosh SE on the grounded workbench pad and put on your grounding wriststrap—but never put on the grounding wriststrap until **after** the CRT is discharged.
3. Remove the video board.
4. Remove the main logic board and place it on the grounded workbench pad. Fill out the return sheet and return the main logic board to Apple.
5. Remove the analog board. (Do not remove the power supply from the analog board.)

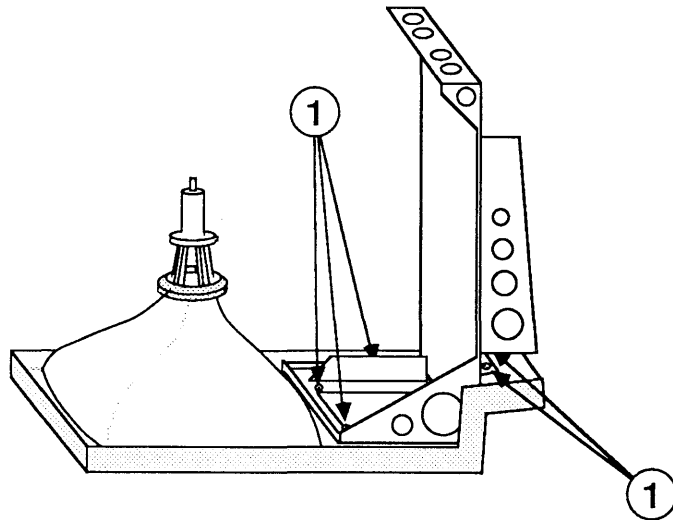

FIGURE 18

6. Remove the SCSI hard disk drive or upper 800K disk drive, whichever is present.
 7. Remove the five Torx screws (Figure 18, #1) that secure the metal chassis to the bezel, and lift out the chassis (with internal disk drive attached).
 8. Remove the CRT and install it in the new bezel.
 9. Assemble the new chassis and bracket (refer to Additional Procedures).
 10. Remove the lower disk drive from the old chassis, and install it on the new chassis.
- Note:** If you are also installing an FDHD Drive Kit, do that installation now.
11. Position the new chassis, with the internal disk drive attached, on the new bezel and install five Torx screws (Figure 18, #1).
 12. If you removed a SCSI hard disk drive from the old chassis, install the drive on the new chassis.
 13. Replace the analog board.

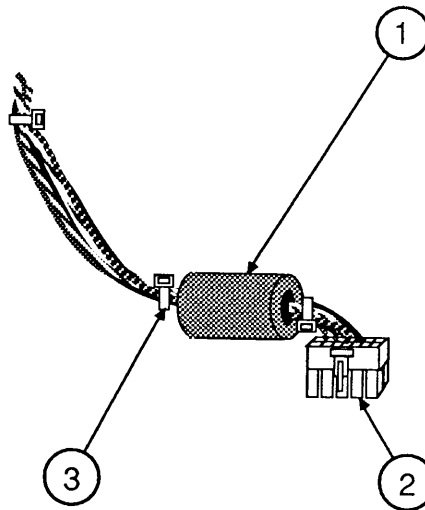

FIGURE 19

14. Install the new Macintosh SE/30 logic board.
15. Position the clip-on ferrite bead (Figure 19, #1) around the video board cable as near the video board connector (Figure 19, #2) as possible. Snap the ferrite bead shut.
16. Install a plastic tie-wrap (Figure 19, #3) on the cable to hold the ferrite bead near the connector. Cut off excess tie-wrap.
17. Replace the video board.
18. Install the new insulating paper shroud over the bottom of the Macintosh SE/30, and replace the cover.
19. Attach the two labels included with the upgrade kit:
 - a) Attach the agency approval label over the previous agency label on the back of the cover.
 - b) Attach the 800K drive label in the groove to the right of the disk drive slot on the new bezel.
20. Be sure to run *System Installer* (version 6.0.3 or greater), if you have not done so already.
21. Run the diagnostics to ensure that the upgrade is installed and functioning correctly. Refer to Section 3, Diagnostics, for further information.

□ FDHD UPGRADE FOR THE MACINTOSH SE

Introduction

The 1.4 MB Apple FDHD disk drive is available to Macintosh SE owners. To upgrade a Macintosh SE so it can support the FDHD drive, you must install the Macintosh SE Apple FDHD Upgrade Kit.

The Upgrade Kit includes the following items:

- Two new ROMs for supporting the FDHD drive
- A single SWIM disk controller chip to replace the IWM chip
- An audio extension cable for reducing EMI interference when using the headphone jack
- The new FDHD disk drive
- System 6.0.3, an Apple product return form, and 800K and FDHD stickers

IMPORTANT: *The System software must be version 6.0.3 or higher to use the FDHD disk drive in the Macintosh SE. If the software is lower than 6.0.2, the drive will be recognized as an 800K mechanism. Run the Installer (version 6.0.3 or higher) to upgrade the System software.*

Materials Required

Grounded workbench pad and wriststrap
Macintosh SE Apple FDHD Upgrade Kit
Small Phillips screwdriver
IC extractor

Upgrade Procedure

1. Remove the cover and discharge the CRT.
2. Move the Macintosh SE onto a soft, grounded workbench pad and put on your grounding wriststrap. (Never put on a grounding wriststrap until after discharging the CRT.)
3. Remove the video board from the neck of the CRT.
4. Remove the SCSI hard disk drive or upper 800K disk drive, whichever is present.
5. Remove the main logic board and place it on the grounded workbench pad.
6. Remove the lower 800K disk drive.

7. Using the IC extractor, remove the IWM chip (Figure 20, #1) and the two ROM chips (Figure 20, #2 and #3) from the logic board.

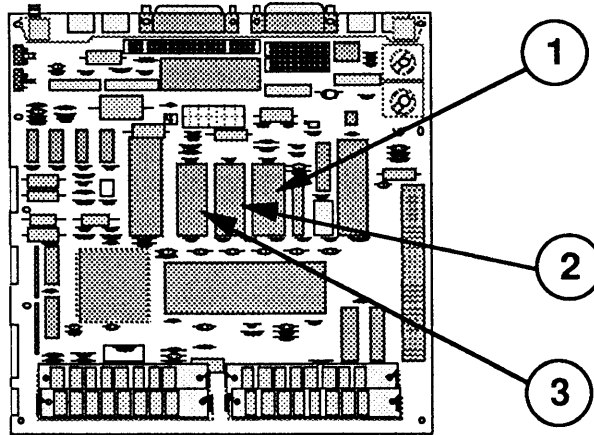

FIGURE 20

8. Install the SWIM chip and two new ROMs as indicated in the following chart:

ROM	P/N	Location	Figure
SWIM	344-0062	D8	20, #1
HI	342-0701	D6	20, #3
LO	342-0702	D7	20, #2

Note: The notch at the end of the SWIM chip and each ROM should face the front of the logic board (toward the SIMMs).

9. Install the lower internal (FDHD) disk drive.
10. Replace the main logic board.

Note: Customers with dual floppy-drive versions of the Macintosh SE may wish to replace both internal 800K drives with FDHD drives.

11. Replace the SCSI hard disk, upper 800K drive, or second FDHD drive, whichever is present.
12. Replace the video board and cover.

- Place the FDHD label in the groove next to the lower disk drive slot on the front bezel of the Macintosh SE as shown in Figure 21, #1. If an 800K drive is mounted above the FDHD drive, place the 800K label (Figure 21, #2) next to the upper disk drive slot on the front bezel.

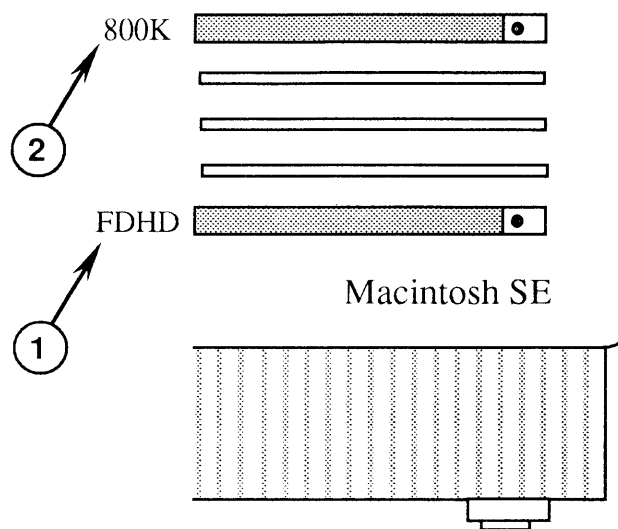

FIGURE 21

- Be sure to run the System Installer (version 6.0.3 or higher), if you have not done so already.
- Run the diagnostics to ensure that the upgrade is installed and functioning correctly. Refer to Section 3, Diagnostics, for further information.
- Return to Apple the two ROMs and IWM chip removed from the customer's logic board.

Note: Remember to give your customer the audio extension cable included with the Upgrade Kit, and explain its use to the customer. To reduce interference, the audio extension cable (with ferrite bead) must be installed between the customer's audio cable and the audio jack at the rear of the Macintosh SE.



Macintosh SE and Macintosh SE/30

Illustrated Parts List

□ CONTENTS

- IPL.3 Internal View (Figure 1)
- IPL.5 Chassis Assembly (Figure 2)
- IPL.7 External Rear Housing (Figure 3)
- IPL.9 Front Bezel (Figure 4)
- IPL.11 Logic Board—Macintosh SE (Figure 5)
- IPL.13 Logic Board—Macintosh SE/30 (Figure 6)
- IPL.15 Analog Board (Figure 7)
- IPL.17 Shipping Fixture, 800K/1.4 MB Drives (Figure 8)
- IPL.17 Dual Internal Drives (Figure 9)
- IPL.19 Internal HDA (Figure 10)

The figures and lists above include all piece parts that can be purchased separately from Apple for the Macintosh SE and Macintosh SE/30, along with their part numbers. These are the only parts available from Apple. Refer to your *Apple Service Programs* manual for prices.

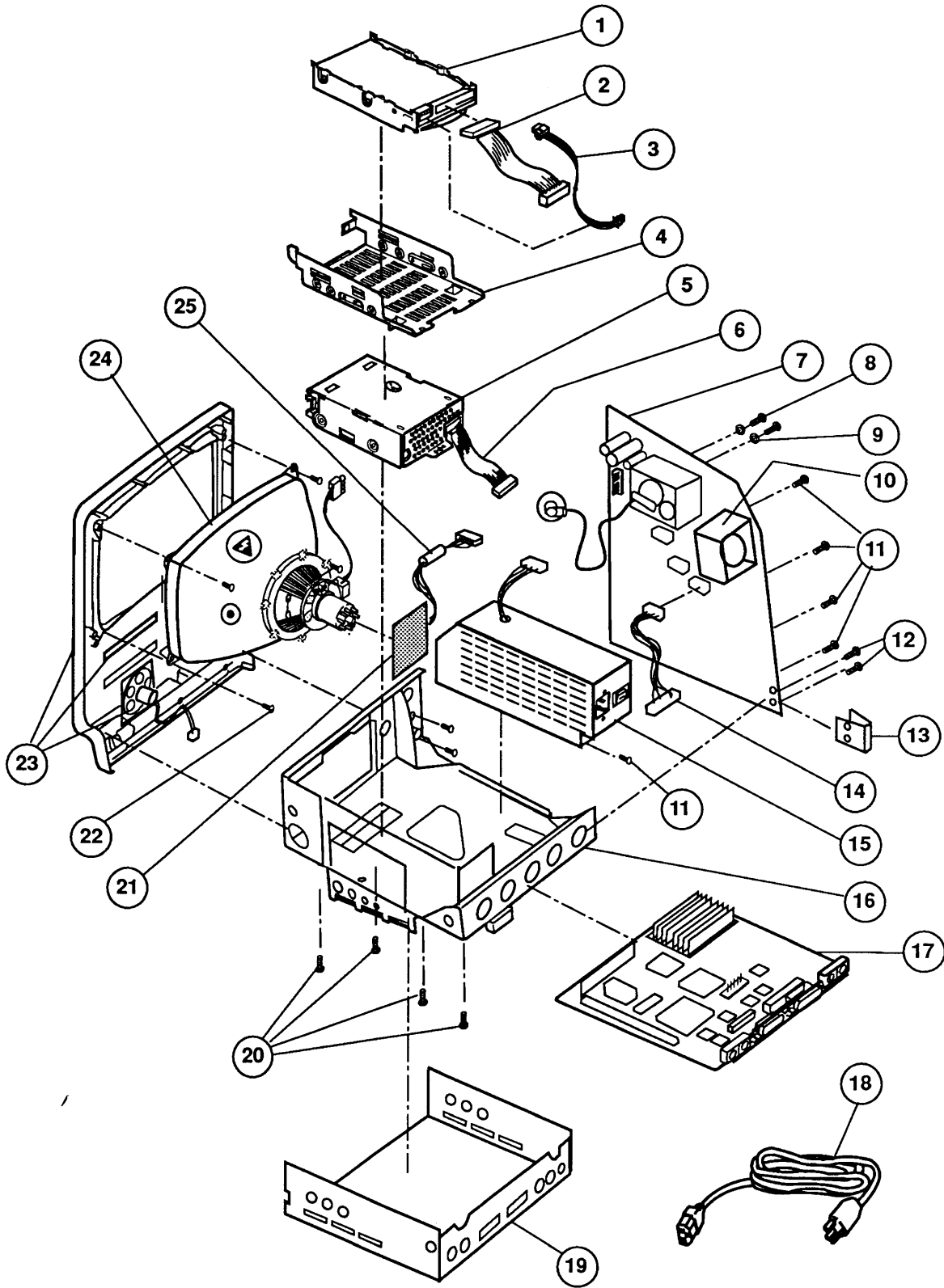

FIGURE 1

□ INTERNAL VIEW (Figure 1)

<u>Item</u>	<u>Part No.</u>	<u>Description</u>
-	590-0527	LED (fits 1-Inch-Height drives)
-	602-0210	Service Packaging, 800K/1.4 MB Drive
1	661-0373	HDA, Internal, 20 MB, 3.5-Inch SCSI, Rev. A
	661-0612	HDA, Internal, 20 MB, 3.5-Inch SCSI, Rev. B
	661-0464	HDA, Internal, 40 MB, 3.5-Inch SCSI
	661-1629	HDA, Internal, 40 MB, 3.5-Inch, 1-Inch-Height SCSI (use carrier 805-0952)
	661-0600	HDA, Internal, 80 MB, 3.5-Inch SCSI
2	590-0211	Cable, Internal HDA SCSI
3	590-0505	Cable, Internal HDA Power (1 x 4-pin)
4	805-5066	Carrier, HDA, Internal, 3.5-Inch, SCSI, High Side-Mounting Holes
	805-0952	Carrier, HDA, Internal, 3.5-Inch, SCSI, Low Side-Mounting Holes (for HDA 661-1629)
5	661-0345	800K Mechanism, Apple 3.5-Inch Drive
	661-0474	1.4 MB Mechanism, Apple 3.5-Inch Drive
6	590-0437	Cable, Internal 3.5-Inch Drive (yellow stripe)
7	661-0371	Analog Board, Macintosh SE and SE/30
8	416-1310	Screw, M 3 x 5 x 10 PNCR
9	860-0282	Washer, Lock, Internal Tooth
10	076-0311	Fan Kit
11	462-3100	Screw, M 3 x .5 x 6
12	470-2101	Screw, M 2.9 x 10
13	805-0576	Lower Ground Clip
14	590-0392	Cable, Logic Board Power Interconnect
15	661-0370	Power Supply, Macintosh SE and SE/30
16	805-0938	Chassis, Macintosh SE and SE/30
17	661-0369	Logic Board, Macintosh SE (replaced by 661-0526)
	661-0490	Logic Board (revised), Macintosh SE, (replaced by 661-0526)
	661-0526	Logic Board, Macintosh SE 800K (without RAM)
	661-0510	Logic Board, Macintosh SE/30 (replaced by 661-0527)
	661-0527	Logic Board, Macintosh SE/30 (without RAM)
	661-0536	Logic Board, Macintosh SE (SuperDrive) (without RAM)
18	590-0380	Cable, AC Power
19	805-5060	Shroud, RFI, Macintosh SE
	805-0969	Shroud, RFI, Macintosh SE/30
20	462-4100	Screw, M 3.5 x .6 x 8, PNCR Rec
21	982-0024	Video Board, Vertical Macintosh SE and SE/30
22	426-1001	Screw, Tap, M 4.22 x 1.41 x 16, Pan, Torx, Zinc (CRT and chassis)
23	810-0399	Front Bezel with Speaker, Slot Cover, Macintosh SE (800K)
	810-0422	Front Bezel with Speaker, Slot Cover, Macintosh SE (SuperDrive)
	630-5499	Front Bezel, with Speaker, Macintosh SE/30
24	076-0103	CRT and Yoke Assembly
25	159-0061	Ferrite Bead, Clamp-on

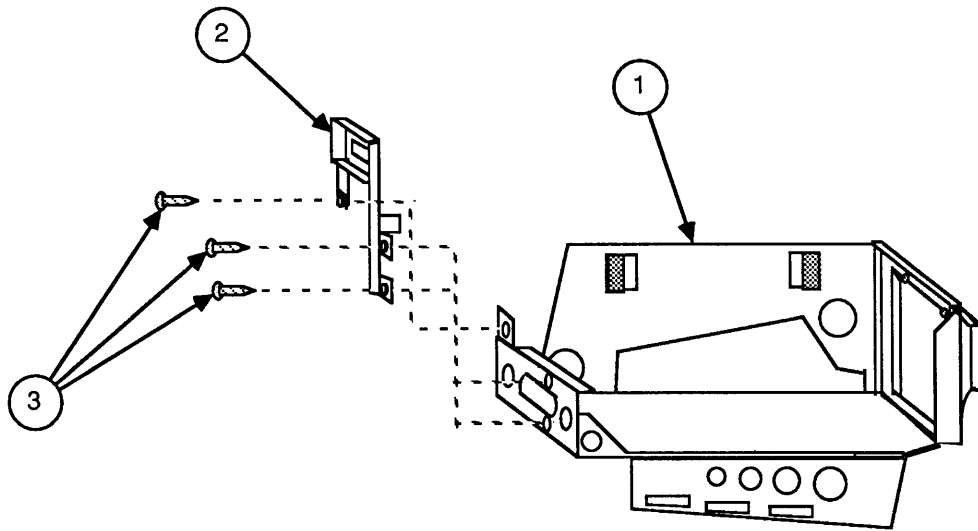

FIGURE 2

□ CHASSIS ASSEMBLY (Figure 2)

<u>Item</u>	<u>Part No.</u>	<u>Description</u>
1	805-0938	Chassis, Macintosh SE and SE/30
2	805-0939	Bracket, Macintosh SE and SE/30
3	470-2101	Screw, M 2.9 x 10

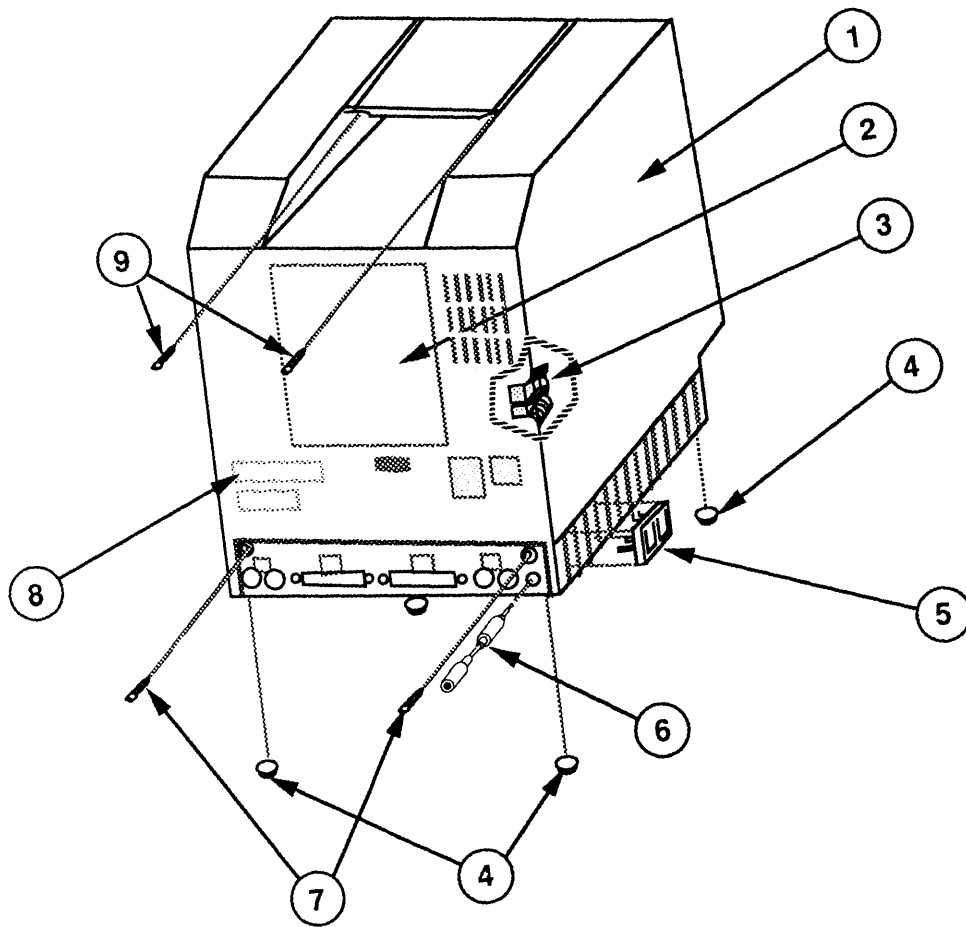

FIGURE 3

□ EXTERNAL REAR HOUSING (Figure 3)

<u>Item</u>	<u>Part No.</u>	<u>Description</u>
1	630-5271	Rear Housing Assembly with Door and Feet
2	825-2021	Agency Approval Label, Macintosh SE
	825-2043	Agency Approval Label, Macintosh SE/30
3	805-0575	Upper Ground Clip
4	865-0051	Foot, Platinum
5	815-1008	Reset/Interrupt Switch
6	590-0612	Audio Extension Cable
7	435-5002	Screw, Tap, 8-32 x .625, Fill, Torx, Black Zinc Oxide (Main Case)
8	815-0986	Rear Housing Door
9	426-1007	Screw, Tap, M 4.22 x 1.41 x 16, Pan, Torx, Zinc (Main Case)

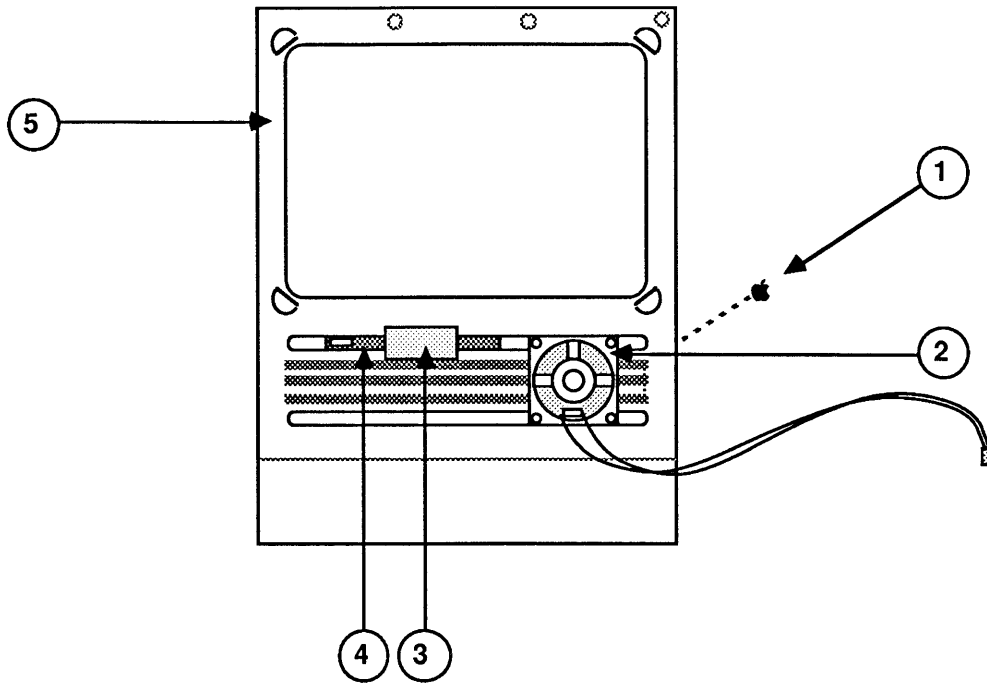

FIGURE 4

□ FRONT BEZEL (Figure 4)

<u>Item</u>	<u>Part No.</u>	<u>Description</u>
1	825-1256	Logo Plate Label, Macintosh SE and SE/30
2	600-0393	Speaker
3	805-0908	Slot Cover Retainer, Macintosh SE
4	630-5330	Slot Cover Bezel, Macintosh SE
5	810-0399	Front Bezel with Speaker, Slot Cover, Macintosh SE (800K)
	810-0422	Front Bezel with Speaker, Slot Cover, Macintosh SE (FDHD)
	630-5499	Front Bezel with Speaker, Macintosh SE/30

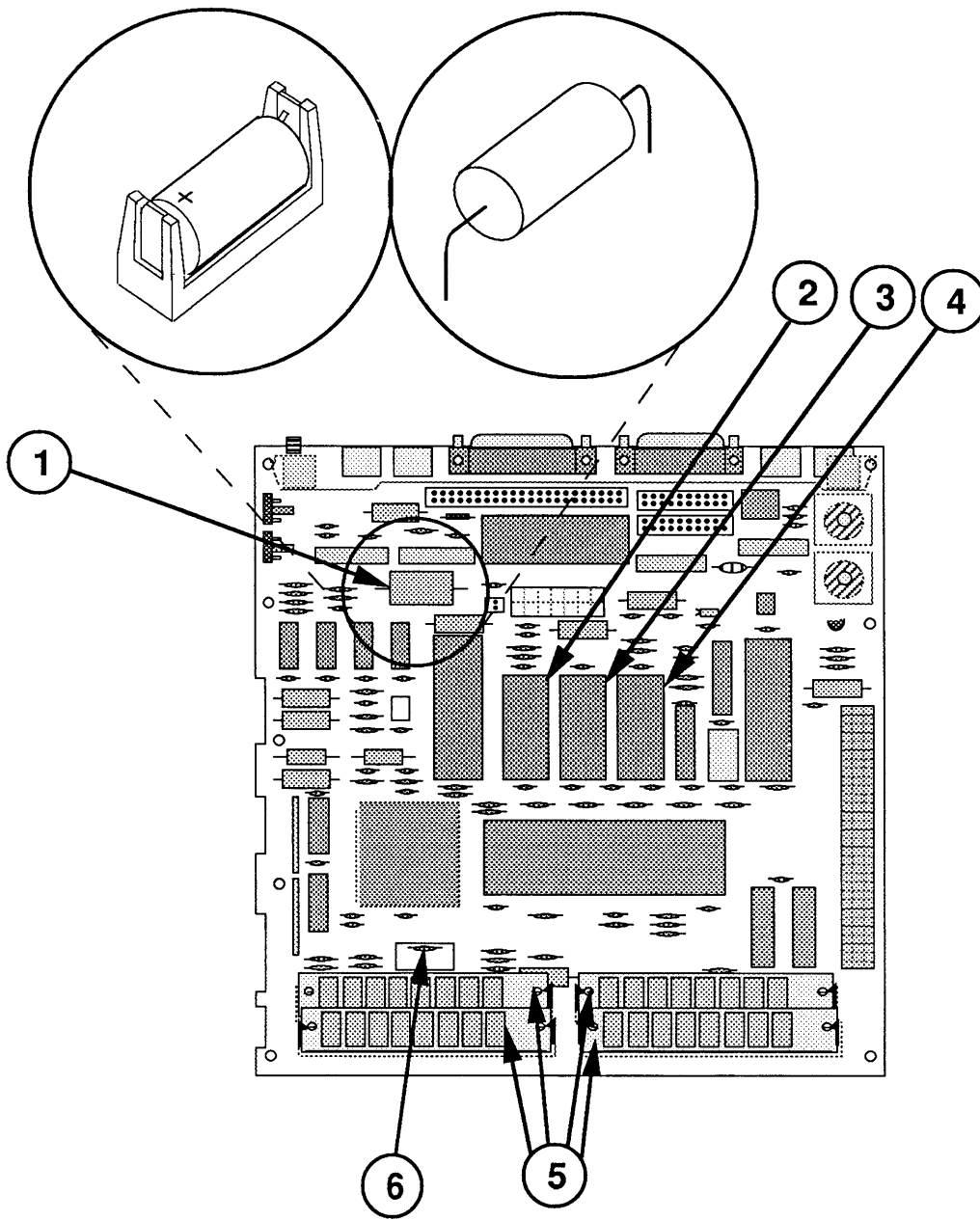



FIGURE 5

□ LOGIC BOARD – MACINTOSH SE (Figure 5)

<u>Item</u>	<u>Part No.</u>	<u>Description</u>
1	742-0009	Lithium Battery (with leads)
	742-0010	Lithium Battery (without leads)
2	661-0701	ROM, High, Macintosh SE Apple SuperDrive Upgrade
3	661-0702	ROM, Low, Macintosh SE Apple SuperDrive Upgrade
4	344-0062	IC, SWIM
5	661-0402	SIMM, 256K, 120 ns
	661-0403	SIMM, SOJ, 1 MB, 120 ns
	661-0410	SIMM, DIP, 1 MB, 120 ns
	661-0494	SIMM, DIP, 256K, 120 ns
	661-0519	SIMM, SOJ, 256K, 80 ns
	661-0520	SIMM, SOJ, 1 MB, 80 ns
6	101-4151	Resistor, 150 Ohms, .25 W, ±5%

IMPORTANT: Refer to the  Quick Reference: SIMM Compatibility chart for SIMM compatibility. Follow this chart carefully! Some SIMMs may falsely appear to be interchangeable.

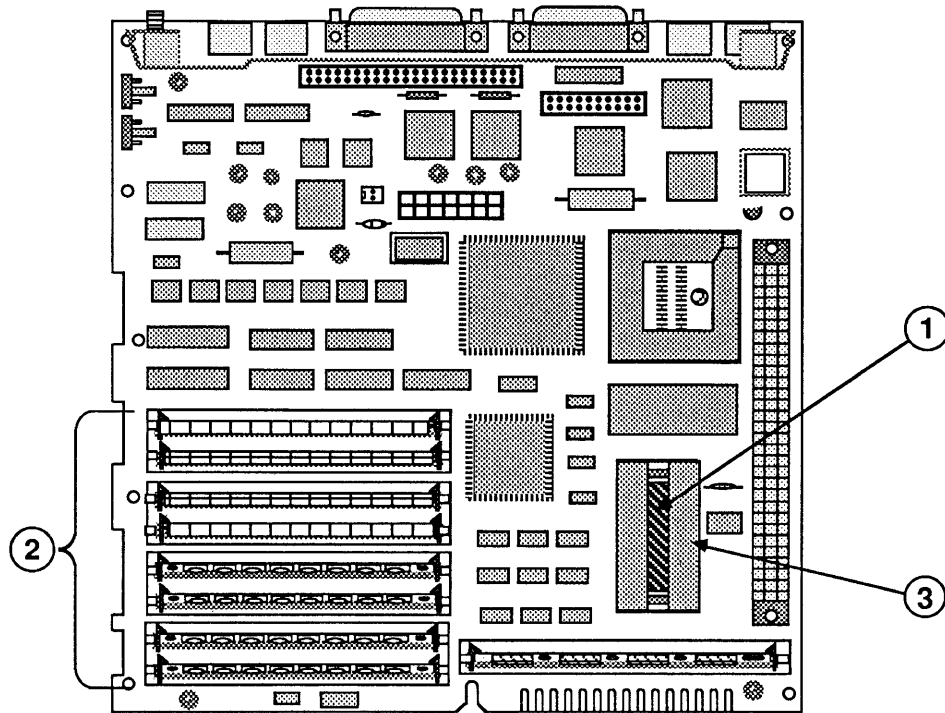



FIGURE 6

□ LOGIC BOARD – MACINTOSH SE/30 (Figure 6)

<u>Item</u>	<u>Part No.</u>	<u>Description</u>
1	742-0011	Lithium Battery (without leads)
2	661-0402	SIMM, 256K, 120 ns
	661-0403	SIMM, SOJ, 1 MB, 120 ns
	661-0494	SIMM, DIP, 256K, 120 ns
	661-0410	SIMM, DIP, 1 MB, 120 ns
	661-0519	SIMM, SOJ, 256K, 80 ns
	661-0520	SIMM, SOJ, 1 MB, 80 ns
	661-0719	SIMM, SOJ, 1 MB, 80 ns
3	520-0344	Battery Holder Cover

IMPORTANT: Refer to the  Quick Reference: SIMM Compatibility chart for SIMM compatibility. Follow this chart carefully! Some SIMMs may falsely appear to be interchangeable.

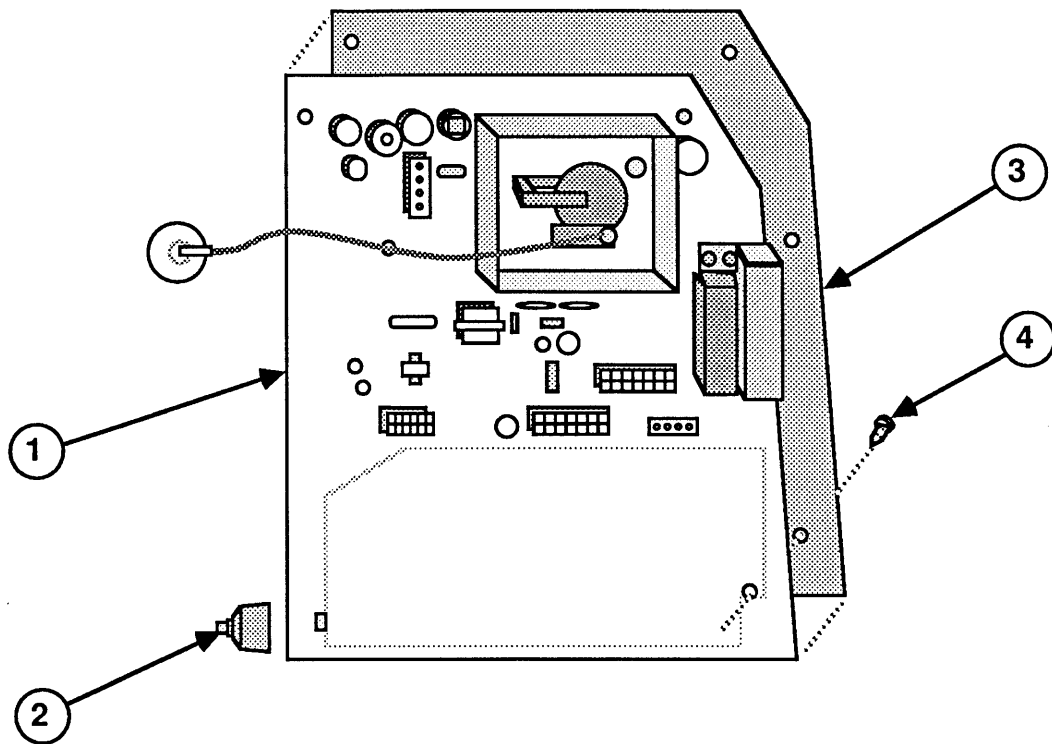

FIGURE 7

□ **ANALOG BOARD (Figure 7)**

<u>Item</u>	<u>Part No.</u>	<u>Description</u>
1	661-0371	Analog Board, Macintosh SE and SE/30
2	865-0047	Brightness Knob
3	725-0020	Insulator, Analog Board
4	830-0240	Fastener, Snap-in Plastic

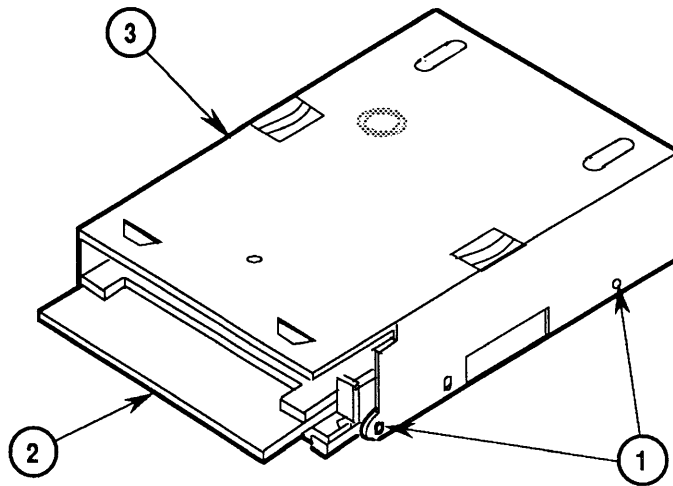

FIGURE 8

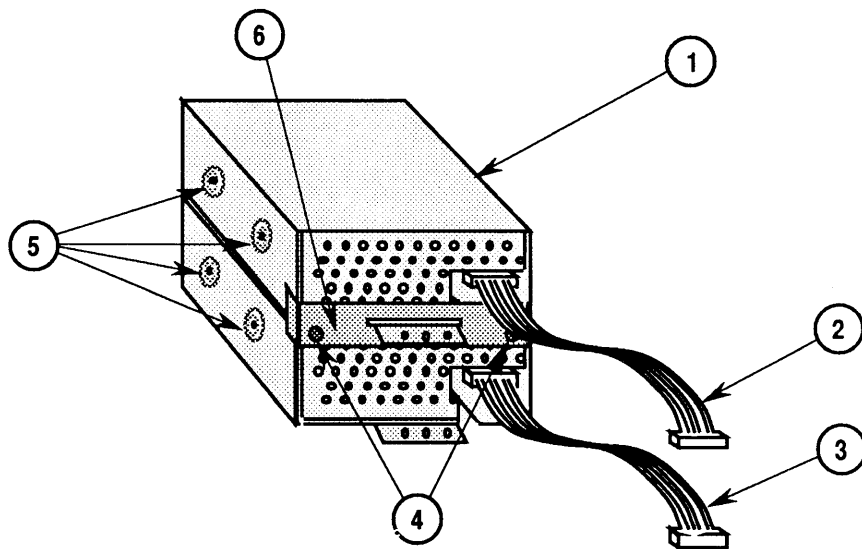

FIGURE 9

□ SHIPPING FIXTURE, 800K/1.4 MB DRIVES (Figure 8)

<u>Item</u>	<u>Part No.</u>	<u>Description</u>
–	661-0345	800K Mechanism, Apple 3.5 Drive
–	661-0474	1.4 MB Mechanism, Apple 3.5 Drive
1	462-3401	Screw, M 3 x 6, with two washers
2	003-0003	Packing Disk, 2-sided (for transporting)
3	805-5050	Metal Housing/Shipping Fixture, 800K/1.4 MB Mechanism

The metal housing/shipping fixture is required when using 800K/1.4 MB drive packaging.

□ DUAL INTERNAL DRIVES (Figure 9)

<u>Item</u>	<u>Part No.</u>	<u>Description</u>
–	076-0439	Dust Shield, 1.4 MB Apple SuperDrive, Package of 5
1	805-5050	Metal Housing/Shipping Fixture, 800K/1.4 MB Mechanism
2	590-0188	Cable, 3.5 Internal Drive (red or yellow stripe)
3	590-0437	Cable, 3.5 Internal Drive (yellow stripe)
4	462-4100	Screw, M 3.5 x .6 x 8, PNCRS Rec
5	462-3401	Screw, M 3 x 6, with two washers
6	805-0914	Back Plate, Drive 2

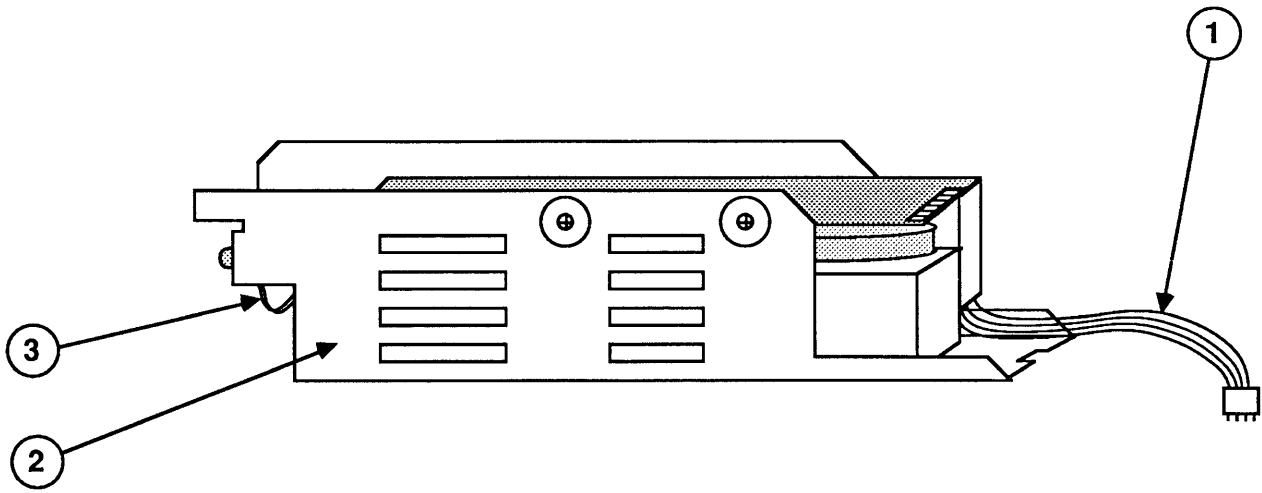

FIGURE 10

□ INTERNAL HDA (Figure 10)

<u>Item</u>	<u>Part No.</u>	<u>Description</u>
-	602-0164	Service Packaging, HDA, 3.5-inch, half-height (replaced by 602-0282 or 602-0308)
-	602-0282	Service Packaging, HDA, 3.5-inch, half-height; and 3.5-inch, 1-inch-height, with carrier
-	661-0373	HDA, Internal, 20 MB, 3.5-inch SCSI, Rev. A
-	661-0464	HDA, Internal, 40 MB, 3.5-inch SCSI
-	661-1629	HDA, Internal, 40 MB, 3.5-inch, 1-inch-height SCSI
-	661-0600	HDA, Internal, 80 MB, 3.5-inch SCSI
-	661-0612	HDA, Internal, 20 MB, 3.5-inch SCSI, Rev. B
1	590-0505	Cable, Internal Power, HDA
2	805-5066	Frame, HDA, Internal, 3.5-inch SCSI
3	590-0237	Cable, HDA LED (red)
	590-0506	Cable, HDA LED (amber)

(

(

(





Macintosh Classic and Classic II

Technical Procedures

□ TABLE OF CONTENTS

Section 1 – Basics	1.2	Product Descriptions
	1.2	Macintosh Classic System Description
	1.2	Macintosh Classic Features
	1.3	Macintosh Classic II System Description
	1.3	Macintosh Classic II Features
	1.5	Connector Identification
	1.8	Theory of Operation
	1.8	Introduction
	1.8	Main Logic Board
	1.12	Power/Sweep Board
	1.12	CRT and Video Board
	1.12	Keyboard and Mouse
	1.13	Apple SuperDrive
	1.14	Care and Handling
Section 2 – Take-Apart	2.3	Introduction
	2.3	About This Section
	2.3	Materials Required
	2.6	Cover
	2.9	Discharging the Cathode-Ray Tube (CRT)
	2.9	Discharge Procedure
	2.11	Anode Cap
	2.13	Power/Sweep Board
	2.17	Memory Expansion Board – Macintosh Classic
	2.19	SIMMs – Macintosh Classic
	2.21	SIMMs – Macintosh Classic II
	2.23	Main Logic Board
	2.25	Internal SCSI Hard Disk Drive
	2.29	Internal 1.4 MB Apple SuperDrive
2.31	Fan	
2.33	Cathode-Ray Tube (CRT)	
2.35	Chassis and Front Bezel	
2.36	Fuse	

**Section 3 –
Adjustments**

- 3.2 Introduction to Adjustments
- 3.3 Exterior (Service Panel) Adjustments
 - 3.3 Introduction
 - 3.3 Materials Required
 - 3.3 Adjustment Setup
- 3.5 Brightness and Contrast Adjustments
- 3.7 Centering Adjustments
- 3.7 Size Adjustments
- 3.7 Focus Adjustment
- 3.8 Interior (Yoke) Adjustment
 - 3.8 Introduction
 - 3.9 Materials Required
 - 3.9 Tilt Adjustment

**Section 4 –
Diagnostics**

- 4.2 Introduction to Diagnostics
 - 4.2 MacTest CL Overview
 - 4.2 Components Tested by MacTest CL
- 4.3 Making Backup Disks
 - 4.3 Copying MacTest CL Disks
- 4.4 Running MacTest CL
 - 4.4 Materials Required
 - 4.4 Starting MacTest CL
 - 4.5 Helpful Hints
 - 4.7 Installing the Loopbacks
 - 4.7 Using the MacTest CL Menus
- 4.11 Running the Tests
- 4.13 SCSI Loopback Jumper Procedure
 - 4.13 To Determine Whether You Need a Jumper
 - 4.14 To Install the Jumper

**Section 5 –
Troubleshooting**

- 5.3 Introduction
 - 5.3 General Information
 - 5.3 How to Use the Symptom Chart
 - 5.3 Things to Remember
- 5.5 Battery Verification
 - 5.5 Introduction
 - 5.5 Materials Required
 - 5.5 Verification Procedure
- 5.6 Symptom Chart
 - 5.6 Video Problems
 - 5.7 Peripheral Problems
 - 5.8 Floppy Drive Problems
 - 5.9 SCSI Problems
 - 5.10 Miscellaneous Problems

**Section 6 –
Additional
Procedures**

- 6.2 SIMM Upgrades – Macintosh Classic
- 6.2 RAM Configurations
- 6.2 SIMM Identification
- 6.2 Installing Upgrades
- 6.3 SIMM Upgrades – Macintosh Classic II
- 6.3 RAM Configurations
- 6.3 SIMM Identification
- 6.3 Installing Upgrades
- 6.4 Battery Replacement
- 6.4 Introduction
- 6.5 Replacement Procedure
- 6.6 Macintosh Classic II Upgrade
- 6.6 Introduction
- 6.6 Upgrade Procedure

**Illustrated
Parts List**

- IPL.3 Internal View (Figure 1)
- IPL.5 Memory Expansion Board – Classic Only
(Figure 2)
- IPL.5 DRAM SIMMs – Classic II Only (Figure 3)
- IPL.7 Internal Drives (Figure 4)

©Apple Computer, Inc., 1990 and 1991. No portion of this document may be reproduced in any form without the written permission of Apple Computer, Inc.

MacTest, Apple Desktop Bus, and Apple SuperDrive are trademarks of Apple Computer, Inc.

Macintosh, ProDOS, Apple, and the Apple logo are registered trademarks of Apple Computer, Inc.

Classic is a registered trademark licensed to Apple Computer, Inc.

MS-DOS is a registered trademark of Microsoft Corporation.

NuBus is a trademark of Texas Instruments.



Macintosh Classic and Classic II

Section 1 – Basics

□ CONTENTS

- 1.2 Product Descriptions
 - 1.2 Macintosh Classic System Description
 - 1.2 Macintosh Classic Features
- 1.3 Macintosh Classic II System Description
 - 1.3 Macintosh Classic II Features
- 1.5 Connector Identification
- 1.8 Theory of Operation
 - 1.8 Introduction
 - 1.8 Main Logic Board
 - 1.12 Power/Sweep Board
 - 1.12 CRT and Video Board
 - 1.12 Keyboard and Mouse
- 1.13 Apple SuperDrive
- 1.14 Care and Handling

□ PRODUCT DESCRIPTIONS

This section provides separate product descriptions and lists of features for the Macintosh® Classic® and Macintosh Classic II computers.

Macintosh Classic System Description

The Macintosh Classic is an enhanced Macintosh SE with a 68000 microprocessor and internal and external expansion options. The Macintosh Classic comes with 1 megabyte (MB) of random-access memory (RAM) installed; upgrades to 2, 2.5, and 4 MB are available.

The customer has a choice of two drive configurations:

- One internal 1.4 MB Apple SuperDrive™ high-density floppy disk drive
- One internal 1.4 MB Apple SuperDrive high-density floppy disk drive and one internal 40 MB SCSI hard disk drive

Macintosh Classic Features

The Macintosh Classic supports the same peripherals as the Macintosh SE and will accept any keyboard or mouse that connects to the Apple Desktop Bus™ (ADB).

The Macintosh Classic includes the following new or improved (as compared to the Macintosh SE) features:

- 1, 2, 2.5, or 4 MB of RAM—with 1 MB soldered on the logic board, 1 MB soldered on the add-on memory expansion board, and the remainder on two Single In-line Memory Modules (SIMMs)
- New read-only memory (ROM) with modifications that support the internal Apple SuperDrive and an external Apple SuperDrive
- Choice of an optional 40 MB internal SCSI hard disk
- Higher capacity wide-input-range power supply
- Fan for cooling
- SWIM (Sanders-Woz integrated machine) disk controller chip, which replaces the IWM (integrated Woz machine) chip for controlling floppy disk drives

- Long-life lithium battery for clock and other Control Panel settings
- One Apple Desktop Bus connector to support the detached keyboard and mouse
- One disk drive port for an external Apple SuperDrive

Macintosh Classic II System Description

Based on a 68030 microprocessor, the Macintosh Classic II is the next generation in the Macintosh Classic line. The 68030 is a true 32-bit microprocessor that is fully compatible with earlier 16- and 24-bit Macintosh microprocessors. This high-performance microprocessor runs at 16 megahertz (MHz) and supports the virtual memory requirements of System 7.0.1.

The Macintosh Classic II comes with 2 MB of soldered RAM and can be upgraded to 4, 6, or 10 MB of RAM.

The customer has a choice of two drive configurations:

- One internal 1.4 MB Apple SuperDrive floppy disk drive and one internal 40 MB SCSI hard disk drive
- One internal 1.4 MB Apple SuperDrive floppy disk drive and one internal 80 MB SCSI hard disk drive

The Macintosh Classic II **requires** System 7.0.1 (or later) and supports all features of System 7, including virtual memory.

Macintosh Classic II Features

The Macintosh Classic II system provides increased performance (running at a speed of up to 2.5 times faster than the Macintosh Classic), greater memory expandability, sound input capabilities, and a larger hard disk capacity. The Macintosh Classic II includes the following system features:

- 16-MHz 68030 microprocessor
- 2 MB of soldered RAM, expandable to 10 MB
- Sound input port and microphone

- New ROM (based on the Macintosh LC) that supports both the internal Apple SuperDrive and an external Apple SuperDrive
- Internal SCSI hard disk (40 MB standard; 80 MB optional)
- High-capacity power supply
- Fan for cooling
- SWIM disk controller chip (which replaces the IWM chip used in the Macintosh Plus) for controlling floppy disk drives
- Long-life lithium battery for clock and other Control Panel settings
- One Apple Desktop Bus connector to support the detached keyboard and mouse

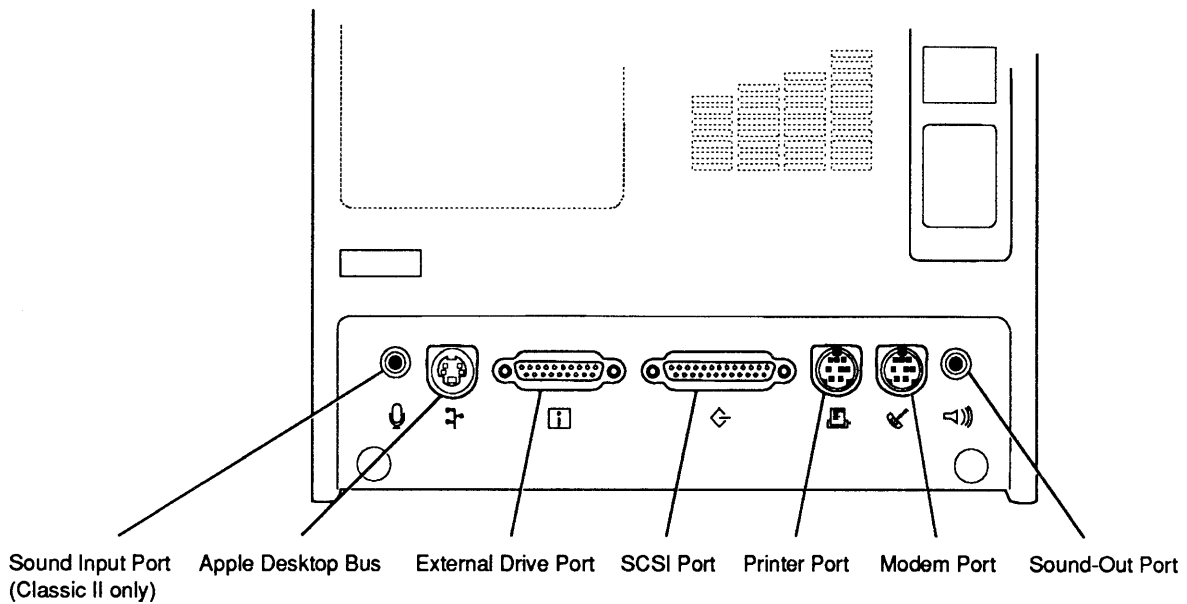

Figure 1-1 Back Panel Connectors

Connector Identification

The external connectors (or ports) differ slightly between the Macintosh Classic and Macintosh Classic II. The Macintosh Classic offers the same external connectors as the Macintosh Plus. The Macintosh Classic II offers all these connectors, plus an additional sound connector (the sound input port). These two models also have different internal connectors as a result of their distinct logic board designs.

Back Panel Connectors

Following is a list of the external connectors provided on the Macintosh Classic and Classic II (**Figure 1-1**):

- Apple Desktop Bus™ port (mini DIN-4)
- External drive port (DB-19)
- SCSI port (DB-25)
- Printer port (mini DIN-8)
- Modem port (mini DIN-8)
- Sound-out port (mini phone jack)
- Sound input port—Macintosh Classic II **only** (mini phone jack)

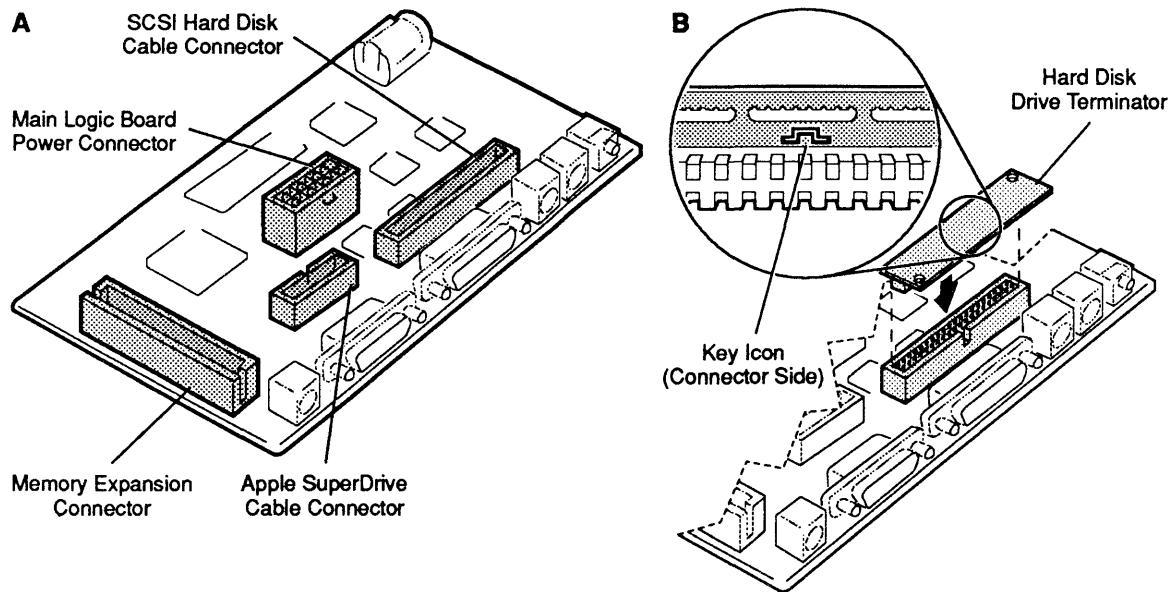

Figure 1-2 Main Logic Board Connectors—Macintosh Classic

*Macintosh Classic
Main Logic Board
Connectors*

The Macintosh Classic logic board has four connectors (**Figure 1-2A**):

- Memory expansion connector
- Internal 1.4 MB Apple SuperDrive cable connector
- Power connector
- Internal SCSI hard disk cable connector

IMPORTANT: *Macintosh Classic computers that do not have an internal hard drive are factory-outfitted with a terminator in the SCSI hard disk cable connector. Some terminators fit the SCSI cable connector in as many as five incorrect positions. To insert the terminator correctly, align the white key icon on the terminator with the notch in the cable connector, as shown in **Figure 1-2B**.*

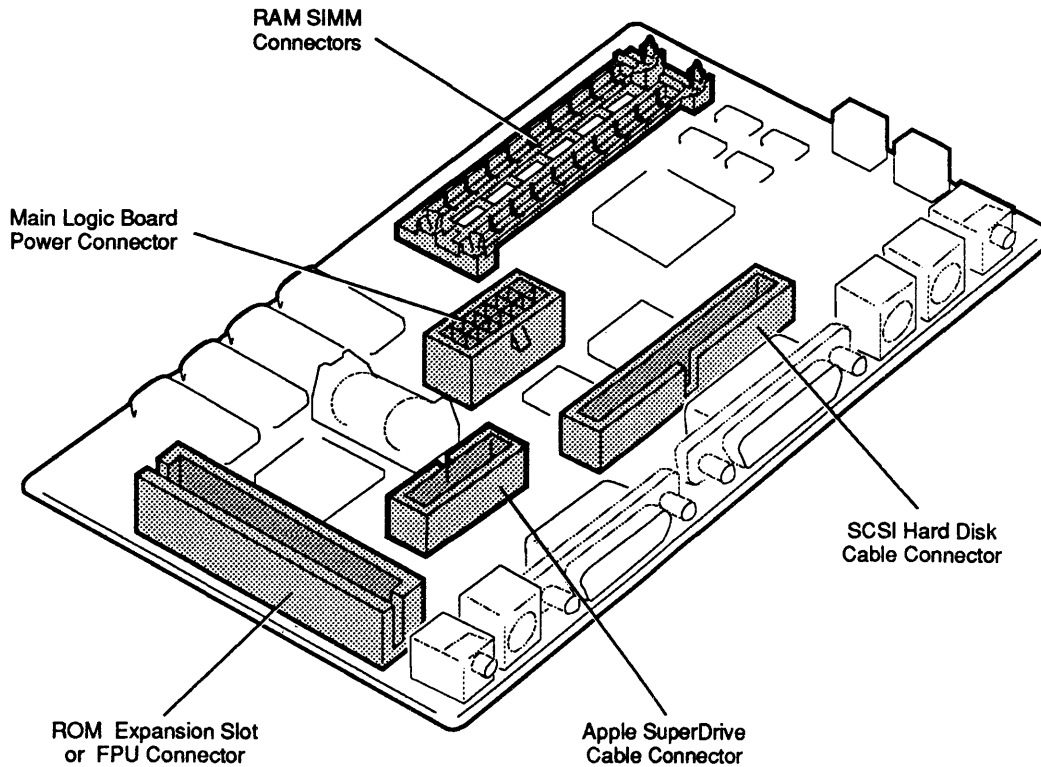

Figure 1-3 Main Logic Board Connectors—Macintosh Classic II

*Macintosh Classic II
Main Logic Board
Connectors*

The Macintosh Classic II logic board has five connectors (Figure 1-3):

- Internal 1.4 MB Apple SuperDrive cable connector
- Power connector
- Internal SCSI hard disk cable connector
- Two RAM SIMM connectors
- Optional ROM expansion slot or FPU (floating-point unit) connector

Note: The ROM expansion slot is not compatible with the Macintosh Classic memory expansion card.

□ THEORY OF OPERATION

Introduction

The Macintosh Classic and Macintosh Classic II computers each have six basic functional units:

- Integrated main logic board
- Power/sweep board
- 1.4 MB Apple SuperDrive floppy disk drive
- Internal SCSI hard disk drive (optional on Macintosh Classic)
- Video display (cathode-ray tube, or CRT)
- Apple Desktop Bus (ADB) keyboard and mouse

Module swapping (repair by replacement of faulty modules) is much faster if you have a basic understanding of the function of each module in the system. If you know what each module does when it functions normally, you can more easily decide which module is at fault when a particular function is missing or degraded. This process is called "logical troubleshooting."

The following section describes the Macintosh Classic and Classic II modules and the functions they perform.

Main Logic Board

Classic: The main logic board in the Macintosh Classic computer is a re-engineered design based on the Macintosh SE logic board. It incorporates the gate array from the Macintosh SE but utilizes extensive surface-mount technology to reduce the board size by almost 50 percent. The 96-pin expansion connector on the Macintosh SE logic board has been replaced by a 44-pin connector for optional memory expansion.

Classic II: The main logic board in the Macintosh Classic II computer is a re-engineered design based on the Macintosh LC logic board. The Classic II logic board features a 68030 microprocessor that supports virtual memory capabilities and results in speeds of up to 2.5 times that of the Macintosh Classic. The Classic II logic board has 2 MB of soldered RAM and provides two SIMM slots for memory expansion to 10 MB of RAM.

CPU

Classic: The central processing unit (CPU) in the Macintosh Classic is a Motorola 68000 microprocessor operating at 8 MHz. The microprocessor obtains instructions from memory, translates them, and carries them out. The microprocessor communicates with all components on the main logic board and with all peripherals.

Classic II: At the heart of the Macintosh Classic II is the Motorola 68030 microprocessor. The 68030 is a true 32-bit microprocessor that is fully compatible with earlier 16- and 24-bit Macintosh microprocessors. This high-performance microprocessor runs at 16 MHz, uses a 16-bit data path, and supports the virtual memory requirements of System 7.0.1.

RAM

Classic: The Macintosh Classic follows the Macintosh SE memory standard (1 MB; expandable to 2, 2.5, or 4 MB), but the Macintosh Classic implementation is unique. The first megabyte consists of 256K x 4-bit DRAM ICs soldered to the main logic board. A 44-pin connector on the main logic board provides memory expansion signals. Installing an optional memory expansion board adds a second megabyte of memory.

The memory expansion board contains a bank of soldered 256K x 4-bit DRAMs, a 44-pin connector for connection to the main logic board, and a pair of SIMM connectors for additional RAM expansion. Installing two 256K or two 1 MB SIMMs in these SIMM connectors brings the total system memory to 2.5 MB or 4 MB, respectively. A programmable array logic (PAL) chip on the main logic board generates corrected column address strobe (CAS) signals for this new design.

Classic II: The Macintosh Classic II has 2 MB of RAM soldered to the main logic board. By installing SIMMs in the two SIMM slots provided, you can increase the amount of RAM on the main logic board to 4, 6, or 10 MB.

ROM

Classic: The read-only memory (ROM) in the Macintosh Classic computer consists of a single 256K ROM chip on the main logic board.

Classic II: The Macintosh Classic II computer has 512K of main ROM. (An optional ROM expansion slot is provided for future use. This expansion slot also serves as an FPU connector.)

Floppy Disk Drives

The Macintosh Classic and Classic II follow the Macintosh Plus disk configuration: one internal floppy drive as standard, plus one optional external floppy drive. The SWIM chip, which supports internal and external Apple SuperDrives, is the disk interface.

Note: The Macintosh Classic and Classic II support the following Apple drive types: HD20, 800K, and the 1.4 MB SuperDrive. Neither model supports the 400K drives.

Serial Ports

The serial ports on both computers are identical to the ports on the Macintosh Plus, except that the Classic and Classic II do not support synchronous modems or GPI (general-purpose input).

Apple Desktop Bus

The Macintosh Classic and Classic II have only one Apple Desktop Bus (ADB) connector on the rear panel. The Apple Desktop Bus is a protocol for connecting computers with input devices. The Macintosh Classic and Macintosh Classic II control the flow of data to connected devices by issuing commands through the Apple Desktop Bus.

SCSI Bus

The Apple SCSI manager supports up to seven daisy-chained SCSI devices, including the internal HDA.

Sound-Out Port

The Macintosh Classic and Macintosh Classic II each provide a dual-channel headphone connector, but both channels are connected to the monophonic sound-out port. (Thus, the Macintosh Classic and Macintosh Classic II do not provide true two-channel output.) A stereo jack, however, is still recommended.

Sound Input Port

Classic: The Macintosh Classic does not provide a sound input port.

Classic II: The Macintosh Classic II provides for sound input through a stereo mini-phone jack. The system records sound digitally and permits the user to mix an external audio source with computer-generated sound and then play the result through the speaker or headphone jack.

The input source should provide a 20-mV amplitude and a 600- Ω input impedance. However, a line input source—such as a CD player, VCR, or tape player—provides a higher input level. Use an attenuating adapter plug to decrease the level of these devices so that they are compatible with the Macintosh Classic II input.

The third pin on the sound input jack (or connector) provides a bias current that can power an electret microphone. This microphone, which ships with the Macintosh Classic II, allows users to digitize voice inputs. The bias voltage that powers the electret has no effect on input devices with monophonic or stereo input plugs.

CAUTION: *Plugging some types of amplifiers into the sound input jack instead of the sound output jack may damage the amplifier. Take care to ensure that the connections to the rear of the computer are made correctly.*

Power/Sweep Board

The power supply combines elements of the Macintosh Plus and the Macintosh SE. The output specifications are as follows:

Regulation

+ 5 V	4.85	to	5.2 VDC
+12 V	11.5	to	12.8 VDC
-12 V	-13.2	to	10.8 VDC

Loading	Min	Max	Peak*
+ 5 V	.5 A	3.48 A	3.71 A
+12 V	.01 A	0.55 A	1.02 A
-12 V	.01 A	0.06 A	0.08 A

* Peak load duration is 2.0 seconds maximum

All other specifications follow the Macintosh SE conventions.

Note: There are two versions of the Macintosh Classic power/sweep board: Rev A and Rev B. These two power/sweep boards are functionally equivalent but are not interchangeable. The Macintosh Classic II always contains the Rev B board.

Contrast Control

The power/sweep contrast control knob (formerly under the front edge of the bezel) has been removed on the Macintosh Classic and Classic II. Control Panel software now controls screen contrast.

CRT and Video Board

The cathode-ray tube (CRT) provides the high-resolution video display. The anode of the CRT receives high voltage from the flyback transformer on the power/sweep board. The power/sweep board also supplies the CRT neck and yoke voltages and signals that enable the CRT to create the video display. The video board (part of the power/sweep assembly) provides video amplification and overvoltage protection to the neck of the CRT.

Keyboard and Mouse

The keyboard connects to the ADB port on the rear of the unit. The mouse connects to the keyboard. All Apple ADB devices communicate with the main logic board via a mini DIN-4 connector. All ADB devices have a microprocessor that makes them intelligent. All except the mouse have ports for daisy-chaining other ADB devices.

Apple SuperDrive

The 3.5-inch, 1.4 MB Apple SuperDrive is a high-density data storage system. Special high-density, 3.5-inch media are required to take full advantage of the increased data storage capacity of this drive. **Do not, however, use high-density media in 400K or 800K disk drives; data written to or read from such media by lower capacity drives will be unreliable.** A simple rule-of-thumb is always to use media appropriate for the drive of lowest capacity; if you have 800K and 1.4 MB disk drives, use only 800K media.

When used with the Apple File Exchange utility, the Apple SuperDrive enables Apple systems (GCR data format) to exchange data with MS-DOS® systems (MFM data format). The Apple SuperDrive can read/write and format 400K, 800K, and 1.4 MB Macintosh disks; 720K and 1.4 MB MS-DOS disks; and 800K ProDOS® disks. When reading data in other formats, the Macintosh first copies MS-DOS or ProDOS data files using the Apple SuperDrive and Apple File Exchange utility, and then uses special file translators to convert the data from one application format to another. (Some applications perform their own translations.)

□ CARE AND HANDLING

The Macintosh Classic and Classic II computers are small enough to be somewhat portable. However, these computers contain a CRT (cathode-ray tube—the picture tube), which operates at very high voltages and contains a high vacuum. If cracked or broken, the CRT can implode (collapse into itself) and scatter glass in all directions.

WARNING: Before working inside this computer, read Section 8, *CRT Safety*, under the *You Oughta Know* tab.

The computer may also contain a hard disk. The hard disk is a mechanical device with moving parts. Rough handling—such as jarring or bumping, especially while the hard disk is operating—could result in a mechanical failure or damage to the information on the hard disk. **Careless handling accounts for more drive failures than all other factors combined.**

Always be sure to

- Leave the computer (with CRT) and hard disk drive modules in their shipping containers until use.
- Use the Apple shipping containers and packing materials when transporting the computer or modules.
- Once the CRT has been discharged and before beginning any repair procedure, place the computer on a grounded workbench mat and put on your grounding wriststrap or heelstrap.
- During power-down, never move a Macintosh Classic II or Macintosh Classic with a hard disk drive. After the power is turned off, the hard disk drive slows and the heads land within 15 seconds. Any jolts to the drive during power-down may cause the heads to crash into the media surfaces.
- Never drop a Macintosh Classic or Classic II. Even a drop of one inch to a hard surface could cause implosion of the CRT and/or a hard disk drive failure.

Macintosh Classic and Classic II

Section 2 – Take-Apart

□ CONTENTS

2.3	Introduction
2.3	About This Section
2.3	Materials Required
2.6	Cover
2.9	Discharging the Cathode-Ray Tube (CRT)
2.9	Discharge Procedure
2.11	Anode Cap
2.13	Power/Sweep Board
2.17	Memory Expansion Board – Macintosh Classic
2.19	SIMMs – Macintosh Classic
2.21	SIMMs – Macintosh Classic II
2.23	Main Logic Board
2.25	Internal SCSI Hard Disk Drive
2.29	Internal 1.4 MB Apple SuperDrive
2.31	Fan
2.33	Cathode-Ray Tube (CRT)
2.35	Chassis and Front Bezel
2.36	Fuse

Note: Detailed instructions for underlined steps can be found elsewhere in this section.

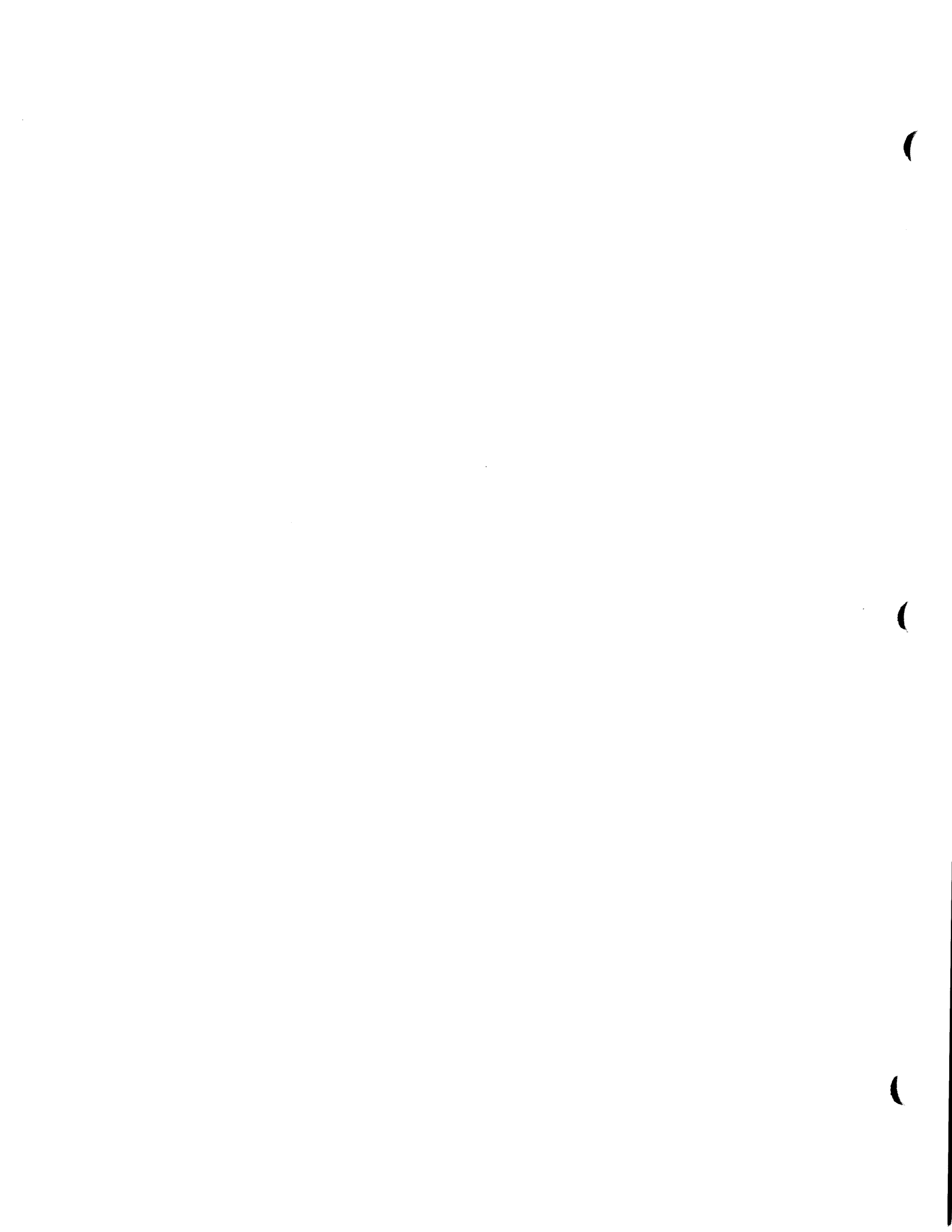

□ INTRODUCTION

About This Section

The flowcharts on the following pages show you at a glance which modules must be removed to access other modules. The charts have a left-to-right, top-to-bottom flow. The take-apart sequence differs slightly from the Macintosh Classic (**Figure 2-1**) to the Macintosh Classic II (**Figure 2-2**).

Detailed instructions for underlined procedures can be found elsewhere in the Take-Apart section; refer back to the earlier procedures and remove the necessary modules before you continue.

When you look at the graphics, pay attention to details, captions, and arrows.

The materials required for the entire take-apart are listed below. This list will give you an idea of what tools you need when taking apart the Macintosh Classic and Macintosh Classic II computers.

Materials Required

Macintosh pull-apart tool (part number 076-8059)
Torque driver
Torx driver (part number 076-8053)
Magnetized #2 Phillips screwdriver
Stump-handled, medium Phillips screwdriver
Small, flat-blade screwdriver
Fuse puller
Art knife
SIMM removal tool (part number 076-8354)
Grounded workbench pad
Grounding wriststrap
Safety goggles
Foam pad (ungrounded)
Needlenose pliers
Alligator lead
CRT discharge tool (part number 076-0381)

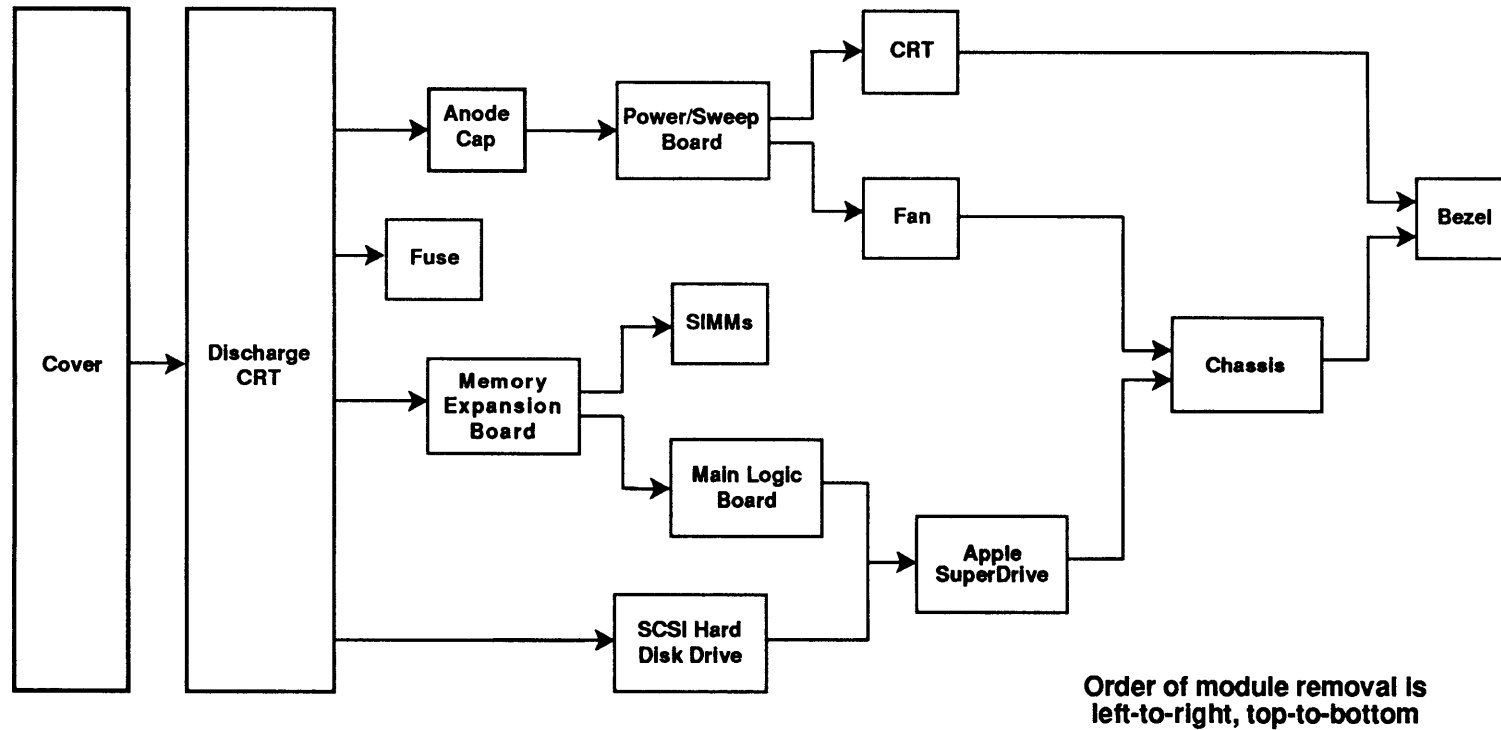

Figure 2-1 Macintosh Classic Take-Apart Flowchart

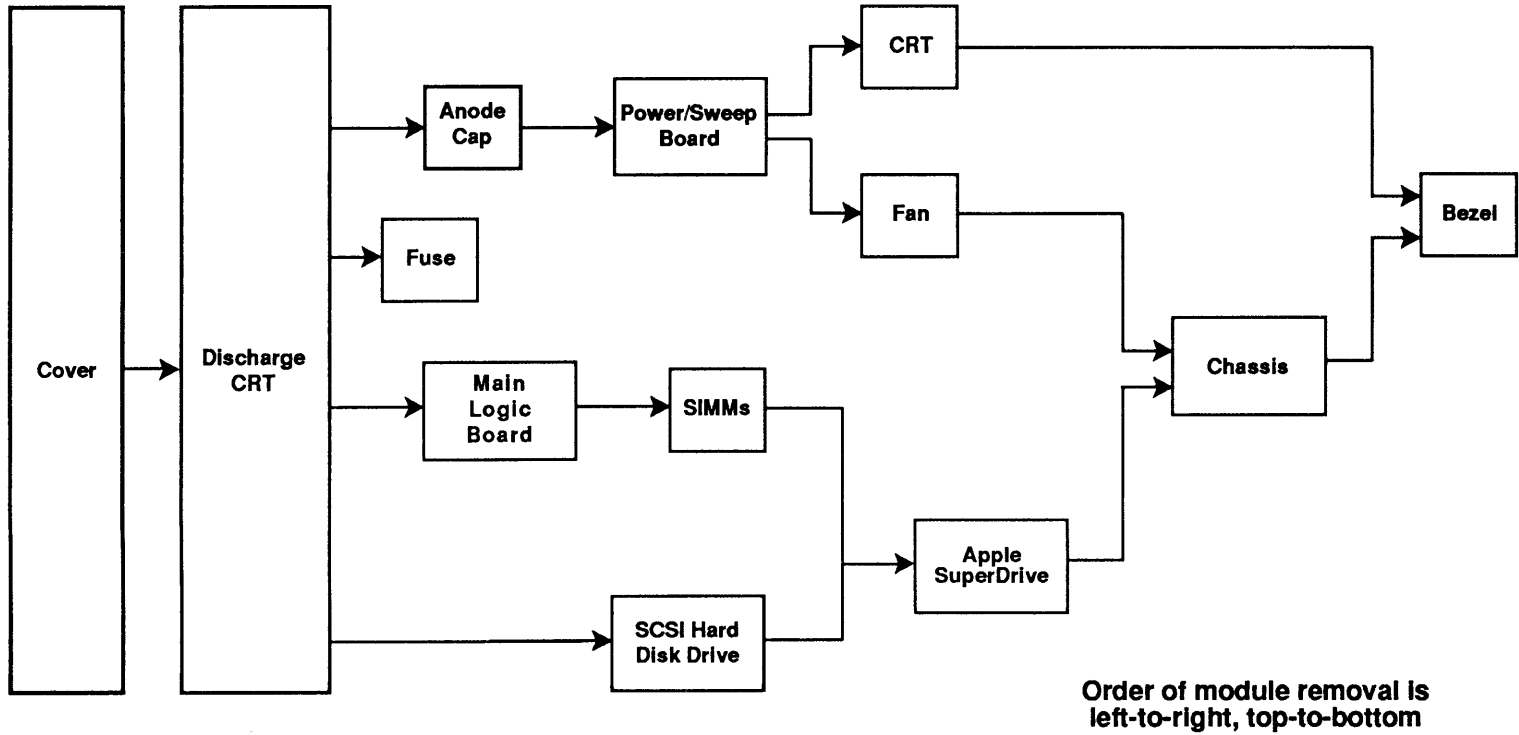

Figure 2-2 Macintosh Classic II Take-Apart Flowchart

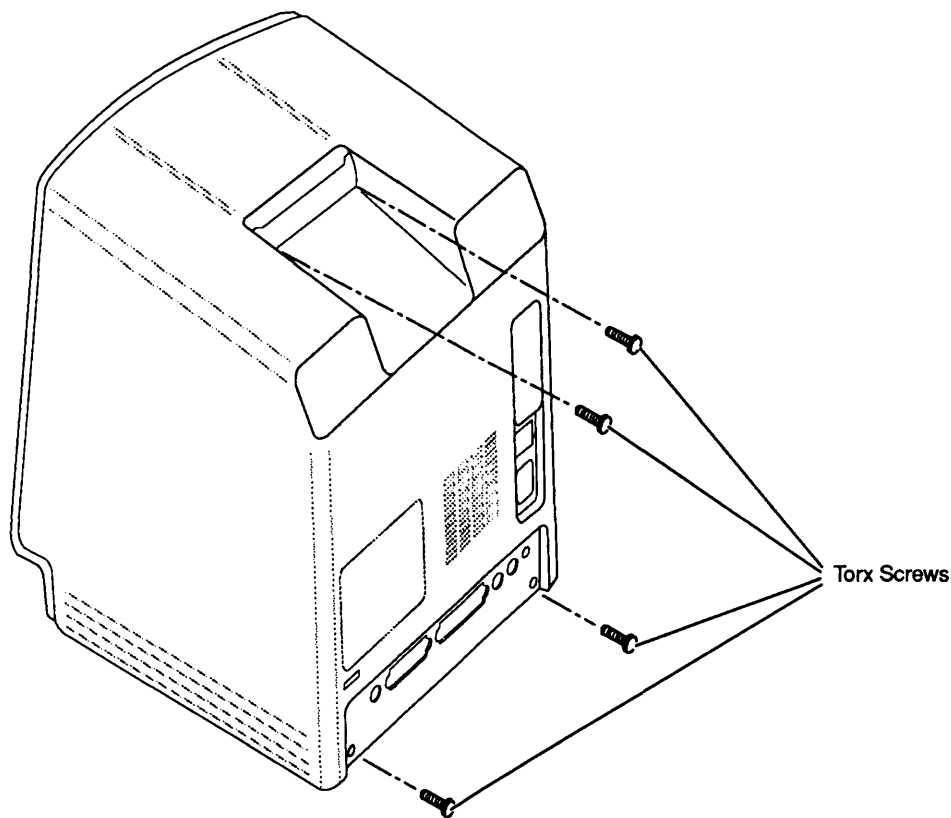

Figure 2-3 Cover

□ COVER

The cover (rear housing) encloses the top, sides, rear, and bottom of the Macintosh Classic or Classic II.

Note: The Macintosh Classic has two styles of rear housing: Style A fits only Classic models using power/sweep board Rev A; Style B fits Classic models using either power/sweep board Rev A or Rev B.

WARNING: *Macintosh Classic and Classic II computers contain high voltage and a high-vacuum picture tube. To prevent serious personal injury and property damage, be sure you read and understand the safety precautions in Section 8, CRT Safety, under the You Oughta Know tab before you remove the back cover. Failure to follow the safety rules could result in serious injury.*

CAUTION: Electrostatic discharge (ESD) can cause severe damage to sensitive microcircuits. The logic boards contain CMOS components, among the most sensitive ICs (integrated circuits or chips) in use today. Handle all printed circuit assemblies and chips, especially removable ones, with care. To prevent ESD damage to RAM chips, CMOS chips, ROM chips, and SIMMs, follow the ESD precautions under the You Oughta Know tab.

CAUTION: *Be especially careful when handling a Macintosh Classic or Classic II with an internal hard disk. Do not drop or jar the unit.*

Refer to **Figure 2-3** when removing and replacing the cover.

Remove

1. Switch off the power. Disconnect the power cord and all other cables from the back of the computer.
2. Place the computer face-down on the workbench pad.
3. Remove the four Torx screws.
4. Carefully lift the cover off the chassis. If the cover is difficult to remove, use the pull-apart tool. (To prevent cosmetic damage to the cover and bezel, do not use a screwdriver to pry off the cover.)

WARNING: *The edges of the metal chassis may be sharp. Handle the metal chassis carefully.*

Replace

1. Place the computer face-down on the workbench pad.
2. Slide the cover over the chassis and fit the cover into the front bezel. (Be sure to use a cover that is compatible with your version of the power/sweep board.)
3. Replace the four Torx screws. (Install the two black screws in the lower two screw holes and the two silver-colored screws in the upper two screw holes.)

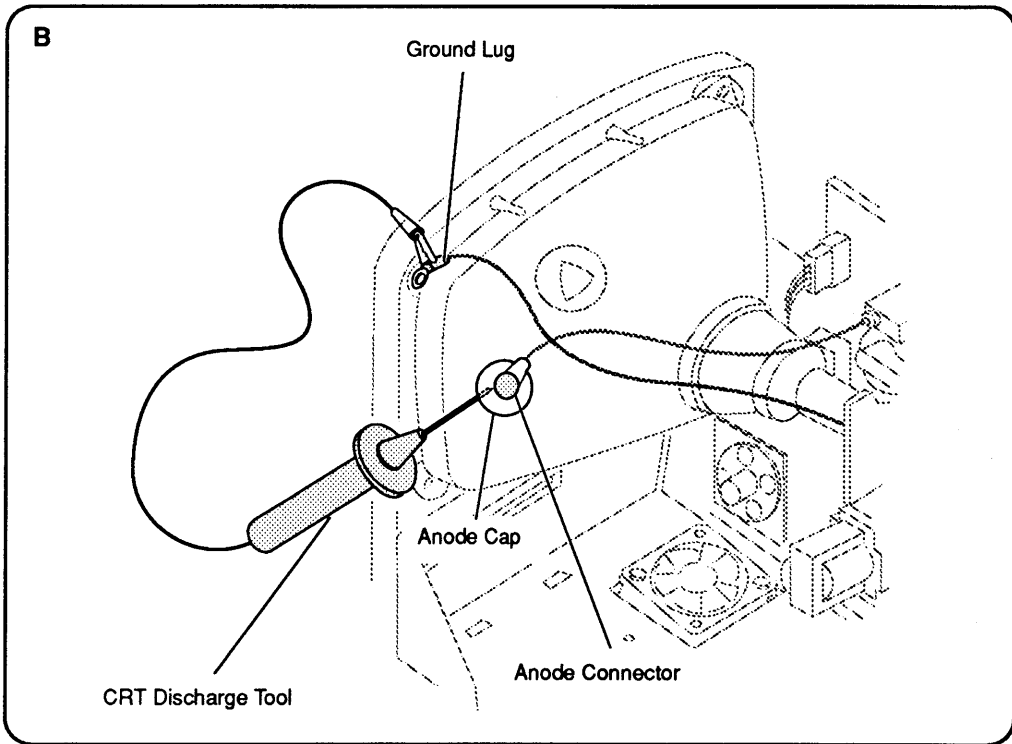
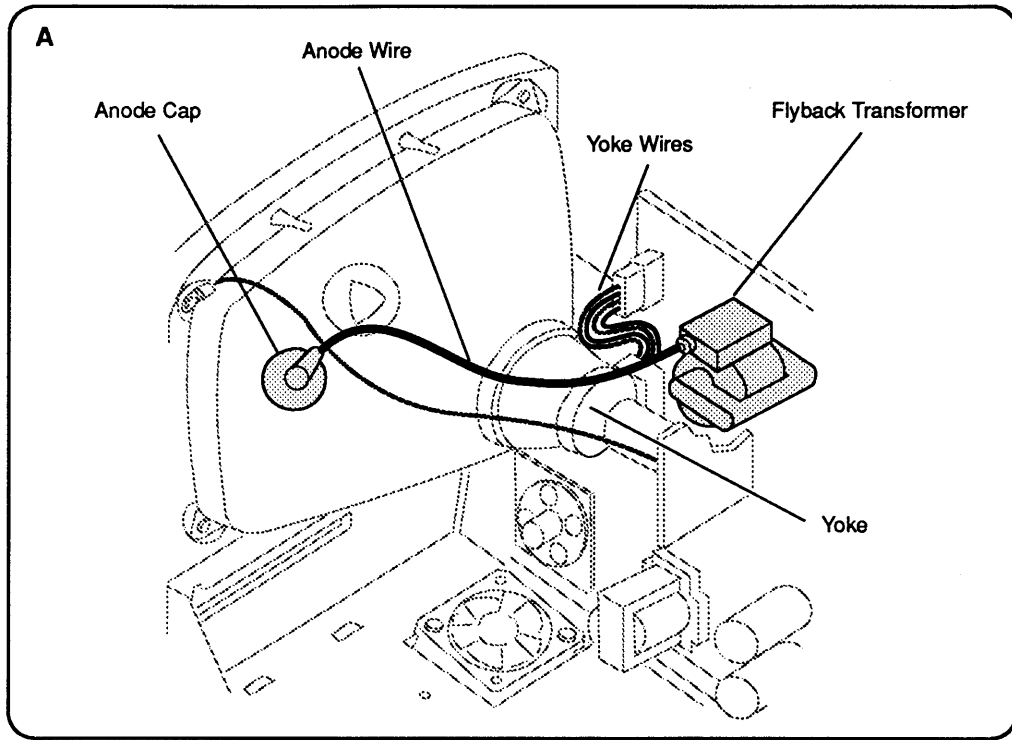

Figure 2-4 Discharging the CRT

□ DISCHARGING THE CATHODE-RAY TUBE (CRT)

Even though the CRT has a bleeder resistor that automatically drains the charge from the CRT when you shut the power off, **you must follow the discharge procedure below to protect yourself in the event that the resistor fails and leaves the anode charged.**

WARNING: Before starting, read the safety precautions and the CRT discharge procedure in Section 8, CRT Safety, under the You Oughta Know tab.

Refer to **Figure 2-4** when discharging the CRT.

Discharge Procedure

1. **Remove your grounding wriststrap and jewelry and put on safety goggles before beginning.**
2. Unplug the unit.
3. Remove the cover.

WARNING: Do not touch the yoke or yoke wires, anode wire, anode cap, or flyback transformer (Figure 2-4A).

4. Set the computer upright on an ungrounded pad, with the back of the unit facing you.
5. Attach the alligator clip on the CRT discharge tool to the metal part of the **ground lug (Figure 2-4B)**.

CAUTION: Discharging the CRT to any part of the chassis other than the ground lug could damage the main logic board and/or the power/sweep board.

6. **Put one hand behind your back and grasp the insulated handle of the discharge tool with your other hand.**
7. Slide the CRT discharge tool probe under the anode cap until the probe touches the anode ring (**Figure 2-4B**).
8. Remove the CRT discharge tool probe from under the anode cap. Remove the alligator clip from the ground lug.

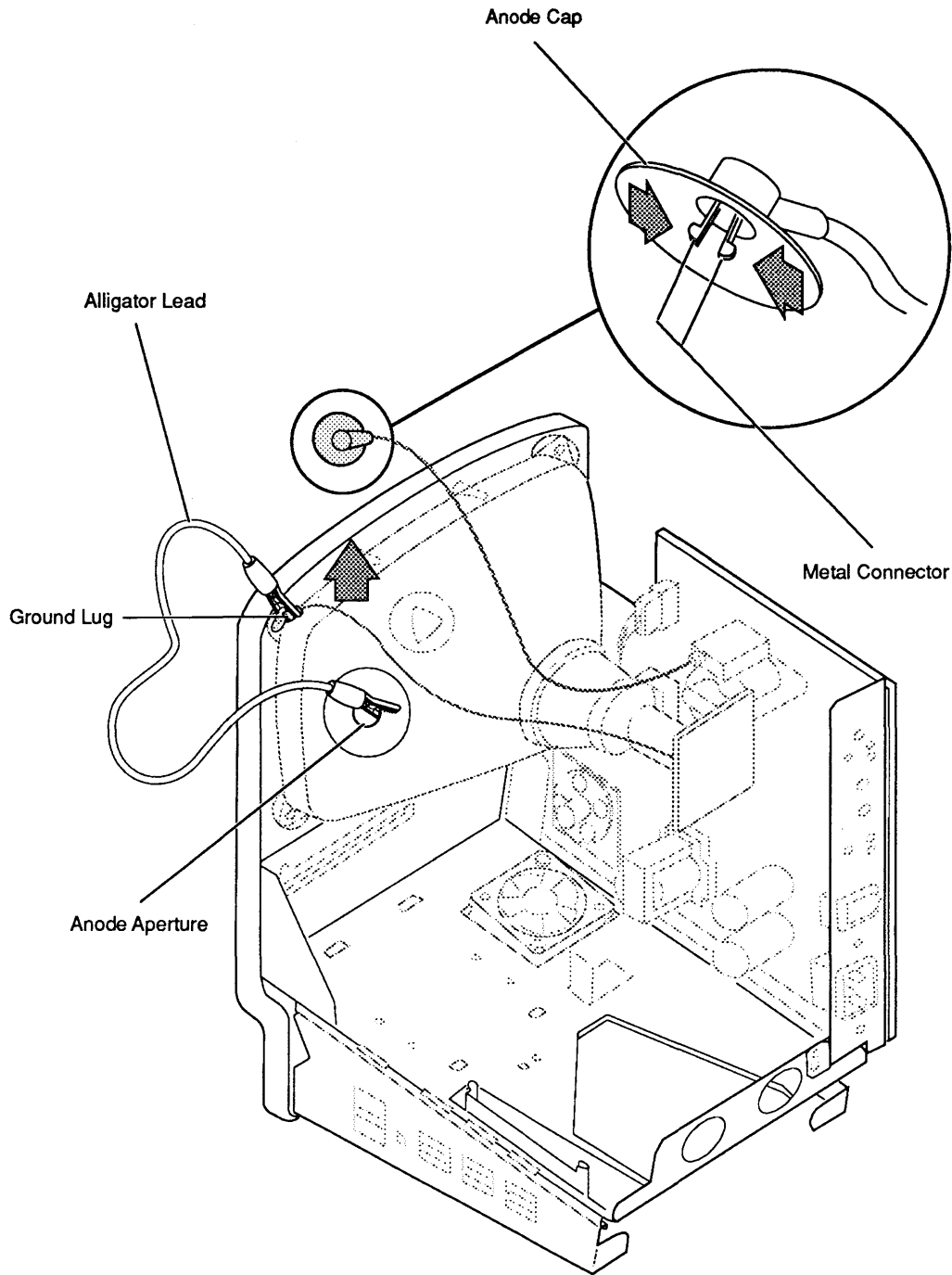

Figure 2-5 Anode Cap

Anode Cap

For some of the following procedures, you may have to remove the anode cap (sometimes also called the anode connector). To do so, first discharge the CRT. Then peel back the rubber edge of the anode cap until you see the metal prongs in the center of the cap (**Figure 2-5**). Note how the prongs clip into the aperture on the CRT. Using the needlenose pliers, compress the two metal prongs and free the connector from the CRT.

To replace the anode cap, compress the two metal connector prongs and insert the prongs securely into the anode aperture of the CRT. Press down around the rubber cap to form a seal against the CRT surface.

Note: If the bleeder resistor fails, a secondary charge could build up over time, even after you discharge the CRT. Thus, to dissipate any residual charge, establish an ongoing ground by clipping one end of an alligator lead to the ground lug and the other end to the anode aperture.

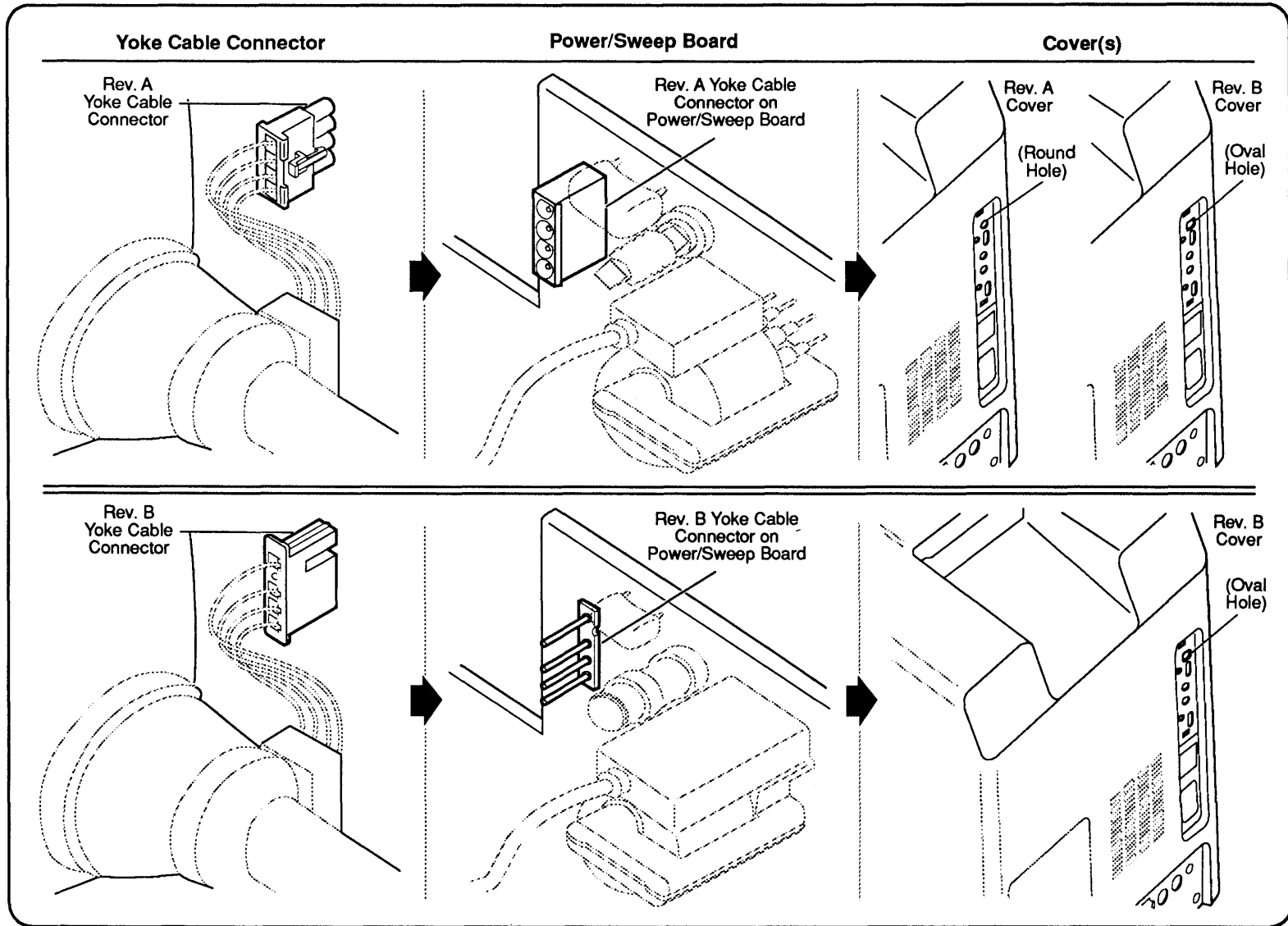

Figure 2-6 Power/Sweep Board Compatibility

□ POWER/SWEEP BOARD

The power/sweep board mounts on the side of the computer chassis. The video board fits on the neck of the CRT but is hard-wired to the power/sweep board and is thus part of the power/sweep assembly.

Note: There are two versions of the power/sweep board: Rev A (Macintosh Classic only) and Rev B (Macintosh Classic or Classic II). These two versions are functionally equivalent, but they are not interchangeable.

To identify the type of power/sweep board in a Macintosh Classic, compare the CRT yoke connector to the ones shown in **Figure 2-6**. The CRT yoke cable connector on power/sweep board Rev A has plastic sleeves surrounding the prongs; the prongs are exposed on power/sweep board Rev B. You must use a power/sweep board with a CRT yoke assembly of the same revision type—that is, Rev A with Rev A, and Rev B with Rev B.

Note: The cover (rear housing) on the Macintosh Classic must also match the power/sweep board revision type. The Rev A board accepts cover Rev A or cover Rev B; the Rev B board accepts only cover Rev B.

Use **Figure 2-6** to verify power/sweep board revisions and compatibility with the CRT yoke and cover.

Remove

Refer to **Figure 2-7** when removing and replacing the power/sweep board.

1. Remove the cover, discharge the CRT, and remove the anode cap.
2. After you discharge the CRT, move the computer onto a grounded workbench pad and put on a grounding wriststrap.
3. Remove the Torx screw that secures the ground wire to the upper corner of the CRT (**Figure 2-7A**).
4. Carefully pull the video board off the neck of the CRT (**Figure 2-7A**). (If sealant holds the board in place, cut the sealant with an art knife.)

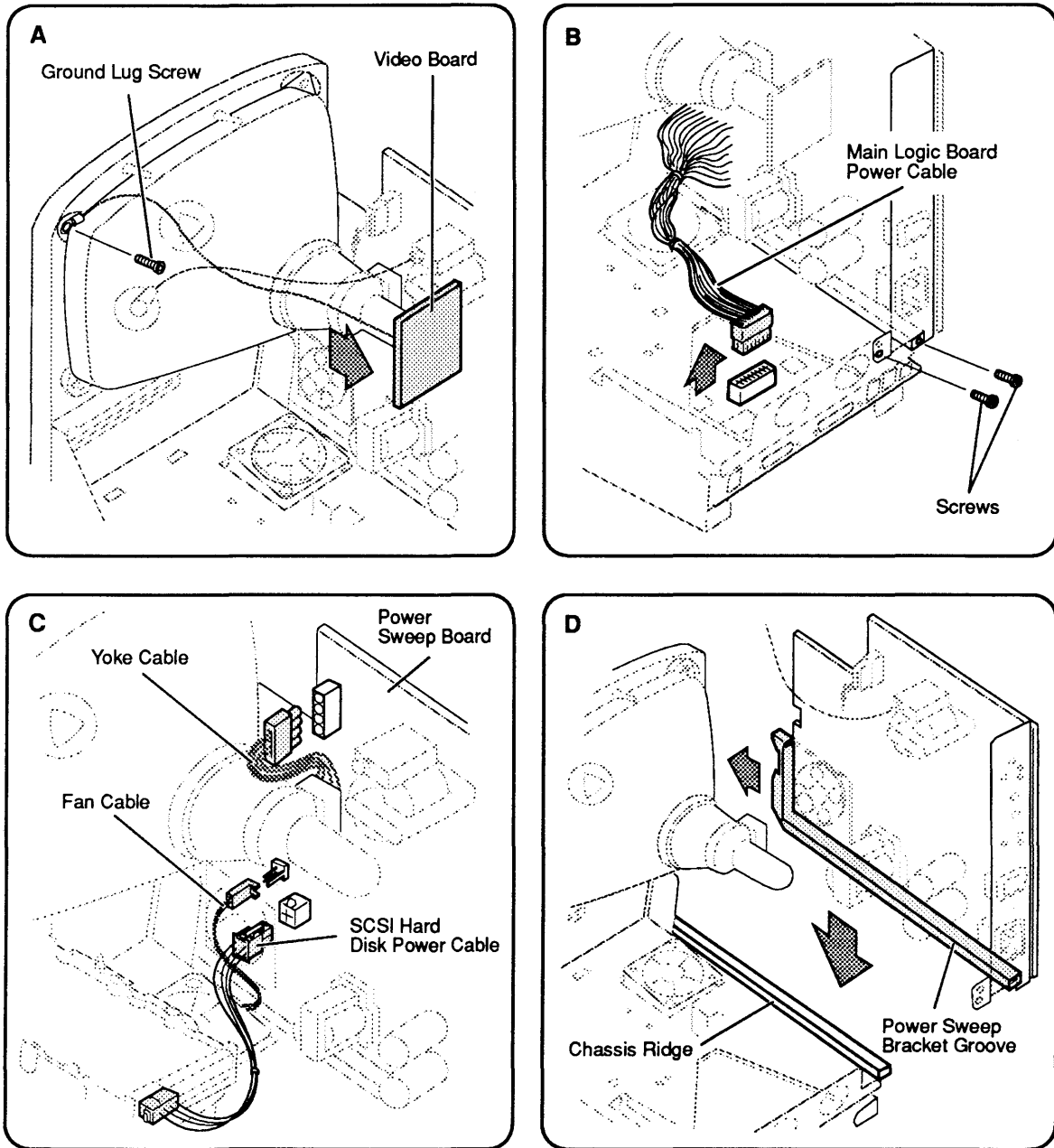

Figure 2-7 Power/Sweep Board

5. Disconnect the main logic board power cable from the main logic board (**Figure 2-7B**).
6. Remove the two Phillips screws that secure the power/sweep bracket to the chassis and pull the board slightly away from the chassis (**Figure 2-7B**).
7. Disconnect the following cables from the power/sweep board (**Figure 2-7C**):
 - Yoke cable (press tab of yoke cable connector on Rev A CRT yoke assembly)
 - Fan cable
 - SCSI hard disk power cable (if present)
8. Lift the board free.

Replace

Use **Figure 2-6** to verify the power/sweep board revision and compatibility with the CRT yoke and cover.

1. Position the power/sweep board near the chassis as shown in **Figure 2-7D**. Reconnect the following cables (**Figure 2-7C**):
 - Yoke cable
 - Fan cable
 - SCSI hard disk power cable (if present)
2. Fit the groove on the bottom of the power/sweep board over the ridge along the side of the chassis (**Figure 2-7D**). Slide the power/sweep board toward the front bezel as far as possible.
3. Replace the two Phillips screws (**Figure 2-7B**).
4. Reconnect the main logic board power cable to the main logic board (**Figure 2-7B**).
5. Replace the video board on the neck of the CRT (**Figure 2-7A**).
6. Position the video board ground wire lug over the upper corner of the CRT and replace the Torx screw (**Figure 2-7A**).
7. Replace the anode cap and the cover.

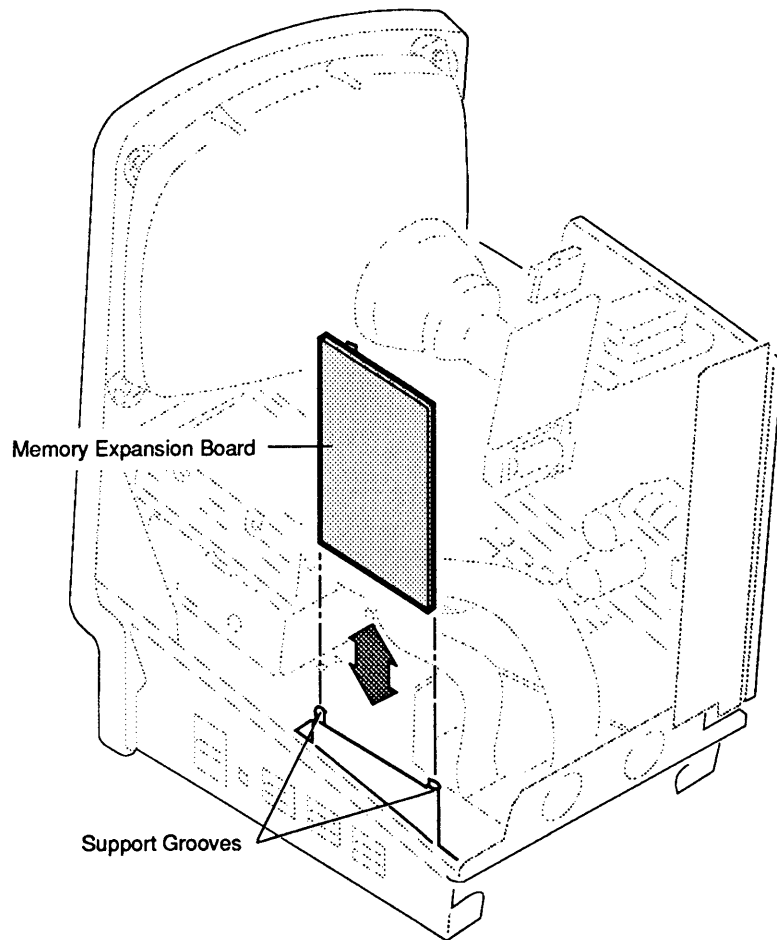

Figure 2-8 Memory Expansion Board—Macintosh Classic

□ MEMORY EXPANSION BOARD – MACINTOSH CLASSIC

The memory expansion board is an **option** on the *Macintosh Classic only*. If installed, it connects at a right angle to the main logic board and is supported by the side of the chassis. The memory expansion board contains 1 MB of soldered DRAM plus one pair of SIMM connectors. (For specific information about SIMM upgrades, see Section 6, Additional Procedures.)

Refer to **Figure 2-8** when removing and replacing the memory expansion board.

Remove

1. Remove the cover and discharge the CRT.
2. Move the Macintosh Classic onto a grounded workbench pad and put on a grounding wriststrap. (Never put on a grounding strap until after you discharge the CRT.)
3. Carefully slide the memory expansion board up to free it from the main logic board and the chassis.

Replace

1. Hold the memory expansion board by the edges and slide it between the support grooves on the chassis until the connector seats securely on the main logic board.
2. Replace the cover.

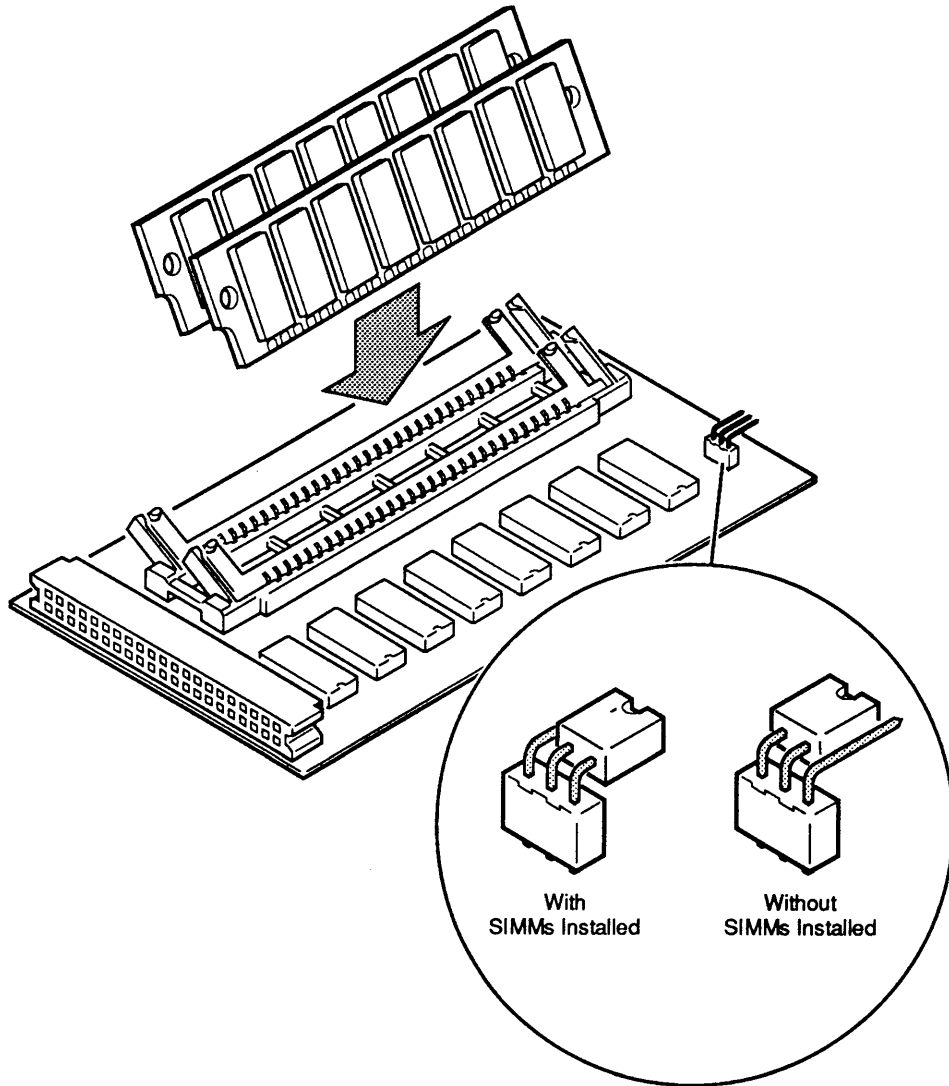

Figure 2-9 SIMMs—Macintosh Classic

□ SIMMS – MACINTOSH CLASSIC

You can expand the memory capacity of the Macintosh Classic by installing two 256K or two 1 MB Apple-supplied SIMMs (single in-line memory modules) on the memory expansion board. The jumper on the SIMM board must be set correctly for the presence or absence of SIMMs. Refer to **Figure 2-9** when removing and installing SIMMs.

Remove

1. Remove the cover and discharge the CRT.
2. After you discharge the CRT, move the computer onto a grounded workbench pad and put on a grounding wriststrap.
3. Remove the memory expansion board and place it on the grounded workbench pad.
4. To remove a SIMM, use the SIMM removal tool. See the *You Oughta Know* tab for instructions.

Install

CAUTION: SIMMs are very susceptible to damage from ESD and skin acid. When installing SIMMs, wear a grounding strap and handle the SIMMs only by the edges!

1. Hold the SIMM by the edges with the contacts on the SIMM pointing down. Insert the SIMM at an angle (bottom forward) into the connector on the memory expansion board. Push back on the top corners of the SIMM. You will hear a click when the SIMM snaps into place.
2. Look at the jumper at the upper edge of the expansion board. For the board to operate properly with SIMMs installed, the jumper must be over the first and second pins from the outside edge. (For board operation without SIMMs, the jumper must be over the second and third pins.) If the jumper is not in the proper position, simply pull the jumper off the pins and reposition it correctly.
3. Replace the memory expansion board.
4. Replace the cover.

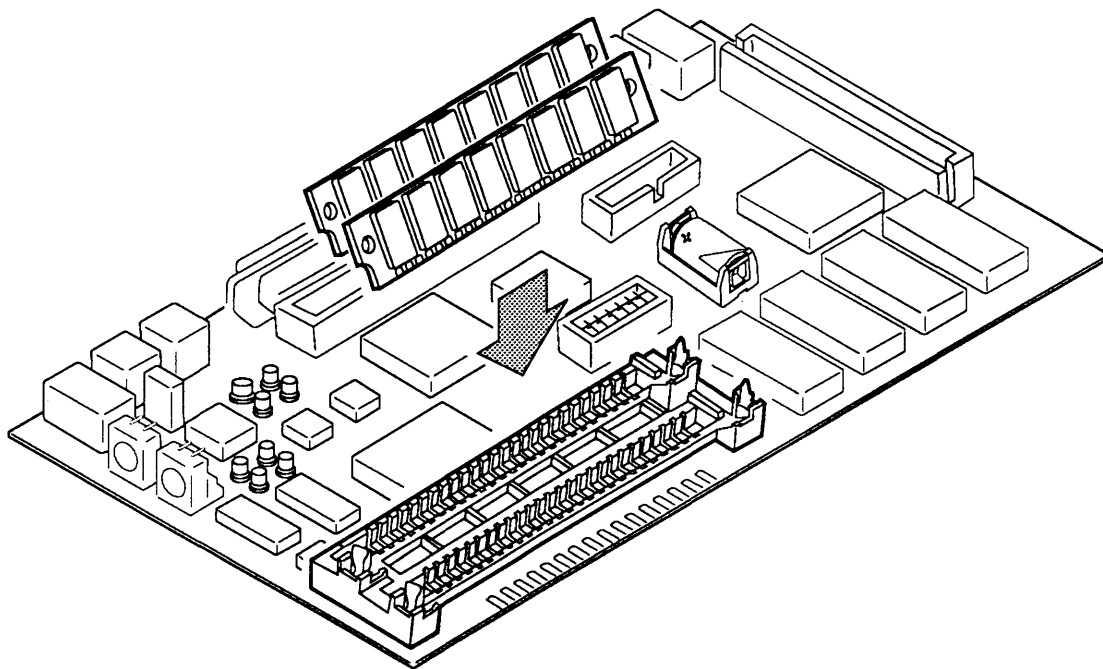

Figure 2-10 SIMMs—Macintosh Classic II

□ SIMMS – MACINTOSH CLASSIC II

You can expand the memory capacity of the Macintosh Classic II by installing two 1 MB or two 2 MB Apple-supplied SIMMs directly onto the main logic board. (The Classic II will also accommodate 4 MB SIMMs when they become available.) Refer to **Figure 2-10** when removing and installing SIMMs.

Remove

1. Remove the cover and discharge the CRT.
2. After you discharge the CRT, move the computer onto a grounded workbench pad and put on a grounding wriststrap.
3. Remove the main logic board and place it on the grounded workbench pad.
4. To remove a SIMM, use the SIMM removal tool. See the *You Oughta Know* tab for instructions.

Install

CAUTION: *SIMMs are very susceptible to damage from ESD and skin acid. When installing SIMMs, wear a grounding strap and handle the SIMMs only by the edges!*

1. Hold the SIMM by the edges with the contacts on the SIMM pointing down. Insert the SIMM at an angle (bottom forward) into the SIMM slot. Push back on the top corners of the SIMM. You will hear a click when the SIMM snaps into place.
2. Replace the main logic board.
3. Replace the cover.

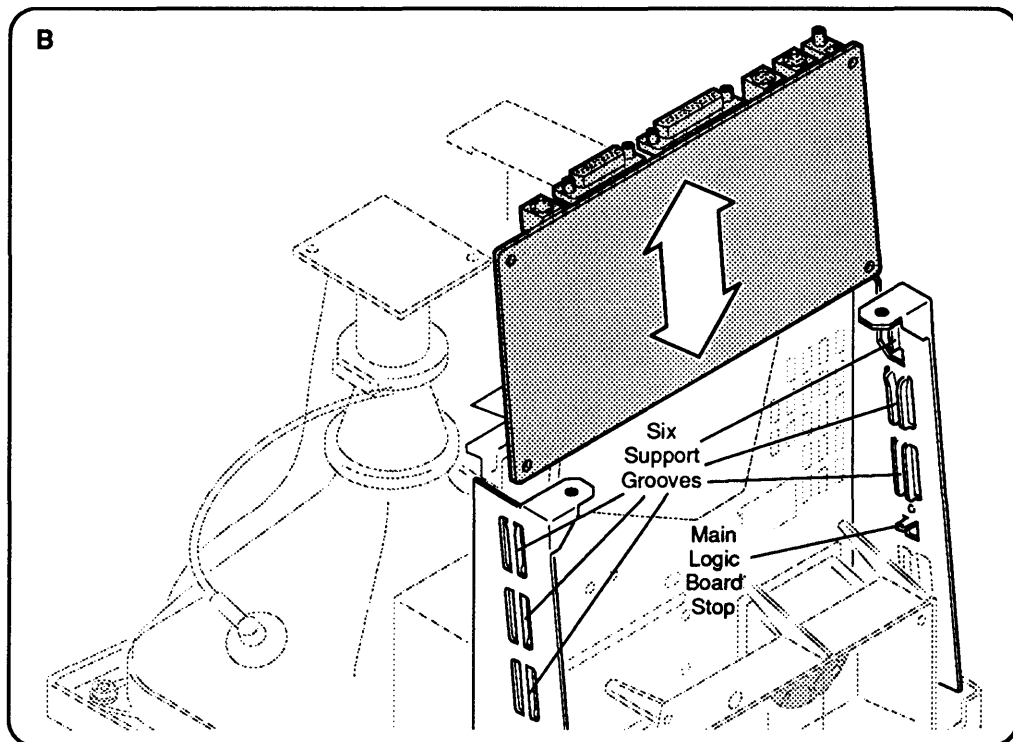
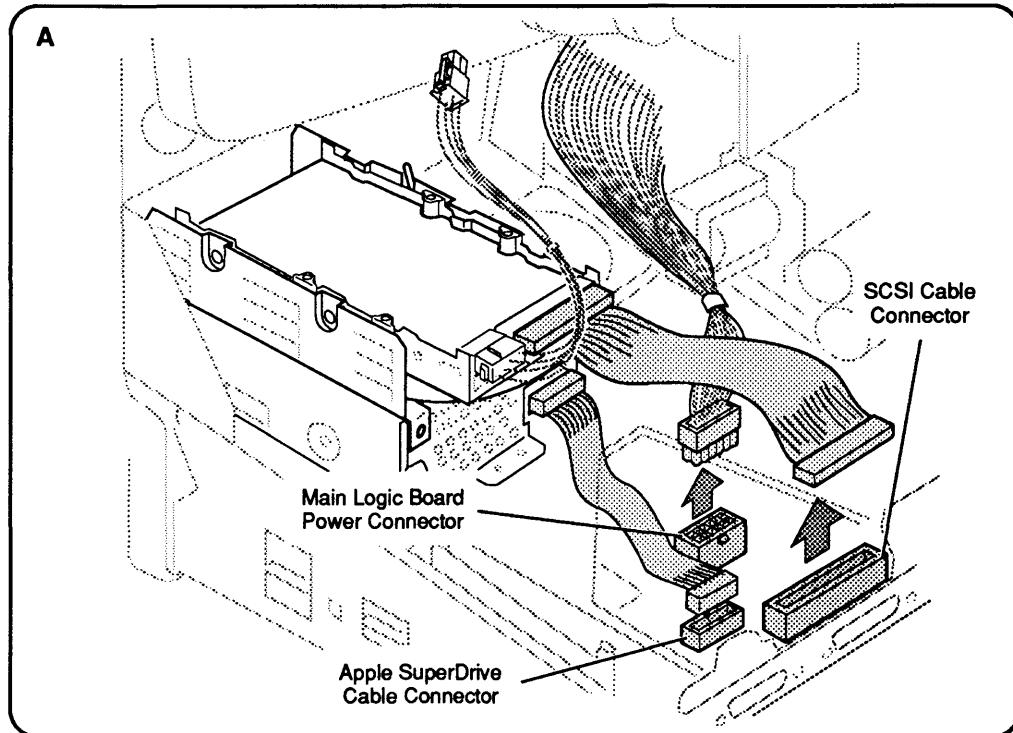

Figure 2-11 Main Logic Board

□ MAIN LOGIC BOARD

IMPORTANT: *If you are removing the logic board from a floppy-only Classic, be sure to remove the internal terminator resistor from the SCSI connector on the old board and install it on the new board. Refer to "Internal SCSI Hard Disk Drive" for instructions on how to install the SCSI terminator.*

Remove

1. Remove the cover and discharge the CRT.
2. Move the computer onto a grounded workbench pad and put on a grounding wriststrap. (Never put on a grounding strap until after you discharge the CRT.)
3. Remove the memory expansion board (Classic only).
4. Disconnect the following cables from the main logic board (**Figure 2-11A**):
 - Main logic board power cable
 - Apple SuperDrive drive cable
 - SCSI connector cable (if present)
5. Place the computer face-down on the workbench pad. Grasp the main logic board by the corners and slide it straight up and out of the chassis (**Figure 2-11B**).

Replace

1. Place the computer face-down on the workbench pad. Hold the main logic board by the edges and slide it into its support grooves on the inside of the chassis; push the board as far as it will go (**Figure 2-11B**).
2. Set the computer upright and connect the following cables (**Figure 2-11A**) to the main logic board:
 - Main logic board power cable
 - Apple SuperDrive drive cable
 - SCSI connector cable, if present
3. Replace the memory expansion board (Classic only).
4. Replace the cover.

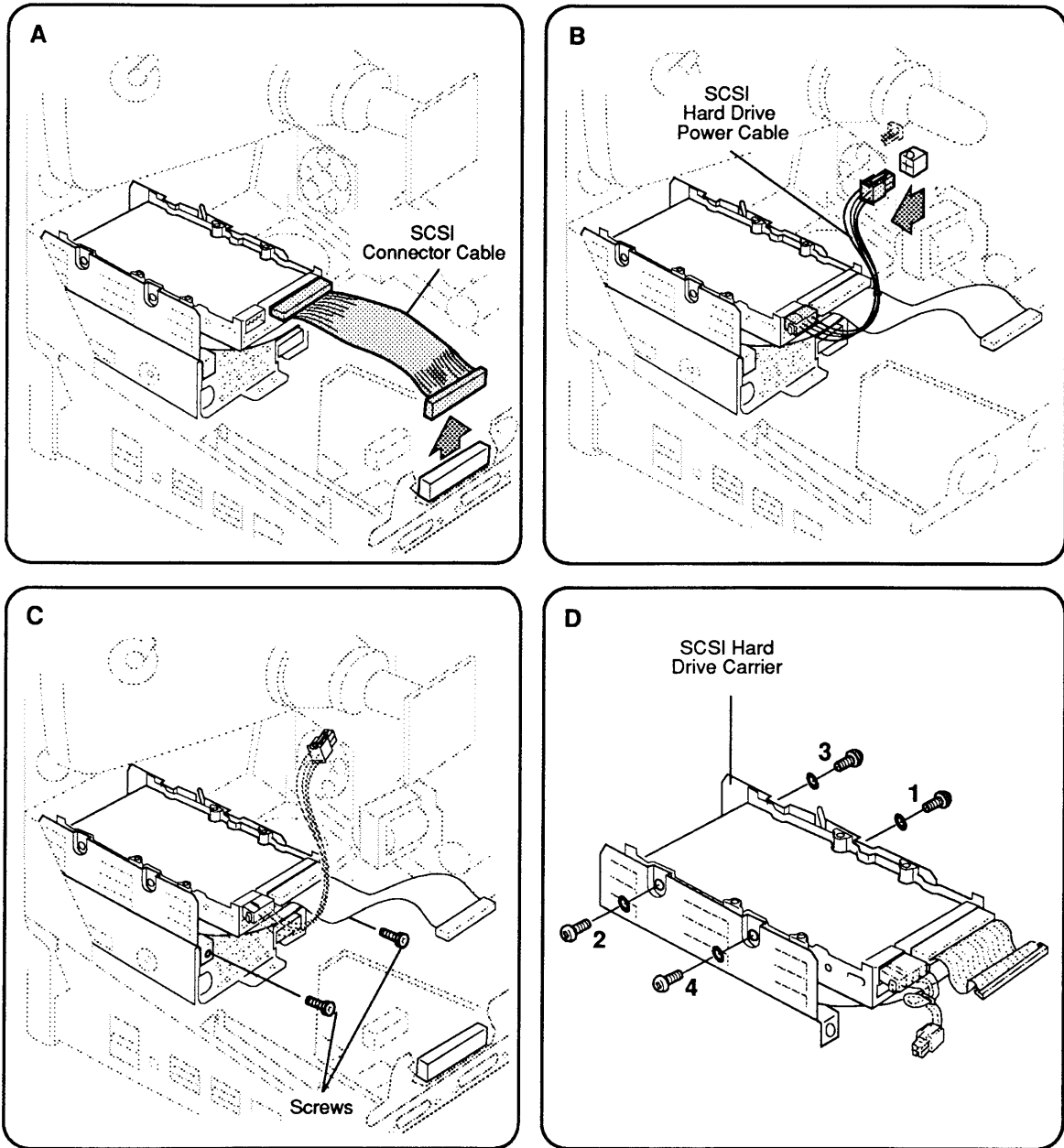

Figure 2-12 Internal SCSI Hard Disk Drive

□ INTERNAL SCSI HARD DISK DRIVE

The Macintosh Classic can have an optional 40 MB internal SCSI hard disk drive above the internal floppy disk drive. **Systems without a hard disk have a SCSI terminator on the main logic board SCSI connector.** The Macintosh Classic II will have either a 40 MB or 80 MB internal SCSI hard disk drive above the internal floppy disk drive.

Remove

1. Remove the cover and discharge the CRT.
2. Move the computer onto your grounded workbench pad and put on your grounding wriststrap. (Never put on a grounding strap until after you discharge the CRT.)
3. Disconnect the SCSI connector cable from the main logic board (**Figure 2-12A**).
4. Disconnect the SCSI hard disk drive power cable from the power/sweep board (**Figure 2-12B**).
5. Remove the two Phillips screws that secure the hard disk drive housing to the Apple SuperDrive housing and lift out the hard disk assembly (**Figure 2-12C**).

IMPORTANT: *If you are removing a hard disk from a Macintosh Classic but not installing a new one, you should install a SCSI terminator on the main logic board SCSI connector. Some terminators fit the SCSI cable connector in as many as five incorrect positions. To insert the terminator correctly, align the white key icon on the terminator with the notch in the cable connector.*

6. If you are replacing the hard disk drive, remove the defective hard disk drive from its silver-colored metal carrier by removing the four Phillips screws and lockwashers from the carrier (**Figure 2-12D**).

CAUTION: *DO NOT loosen or remove any of the four Torx screws that secure the black cover to the drive. Loosening or removing these screws can cause irreparable damage to the hard drive.*

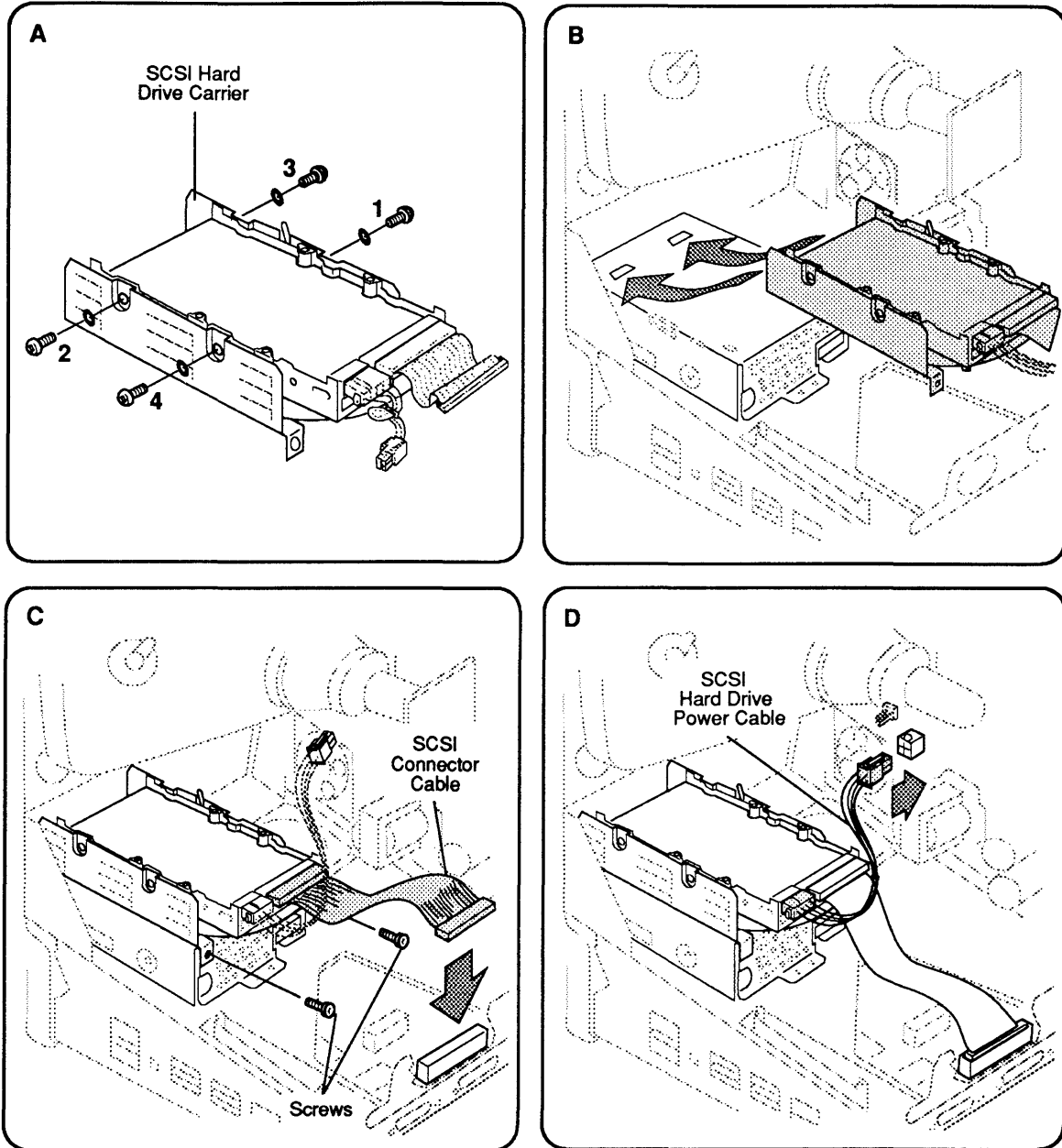

Figure 2-13 Hard Disk Drive Carrier

Note: If you are replacing the hard disk drive, retain the power cable and the SCSI connector cable. You will need both for the new drive.

Replace

If you are replacing a defective hard disk drive, begin with step 1. If you are reinstalling a drive that you removed (but which remains in its silver-colored metal carrier), begin with step 3.

1. Position the silver metal carrier on the replacement hard disk drive. Loosely install the bracket with the four lockwashers and Phillips screws.
2. Using a torque driver and following the sequence shown in **Figure 2-13A**, torque the four Phillips screws to 8.0 in-lbs.

CAUTION: To avoid damage to the hard drive, be careful not to overtorque the screws.

3. Replace the 50-pin SCSI connector cable on the hard disk drive assembly.
4. Replace the SCSI power cable on the hard disk drive assembly.
5. Slide the SCSI hard disk drive assembly over the Apple SuperDrive so that the tabs on the bottom of the hard drive housing mesh with the holes on the top of the Apple SuperDrive housing (**Figure 2-13B**).
6. Replace the two screws that secure the SCSI hard disk drive housing to the Apple SuperDrive housing (**Figure 2-13C**).
7. Reconnect the SCSI connector cable to the main logic board (**Figure 2-13C**).

IMPORTANT: If you are installing a hard disk in a system that has not previously had one, you must remove the SCSI terminator from the main logic board SCSI connector before you can connect the hard disk SCSI connector cable to the main logic board.

8. Reconnect the SCSI hard disk drive power cable to the power/sweep board (**Figure 2-13D**).
9. Replace the cover.

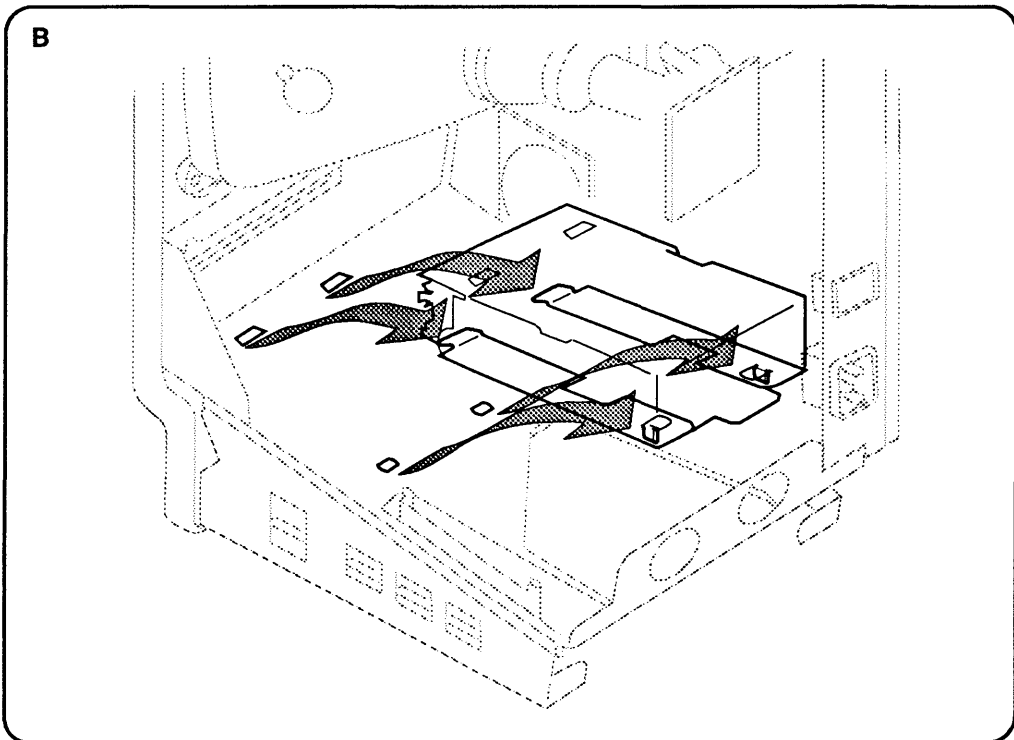
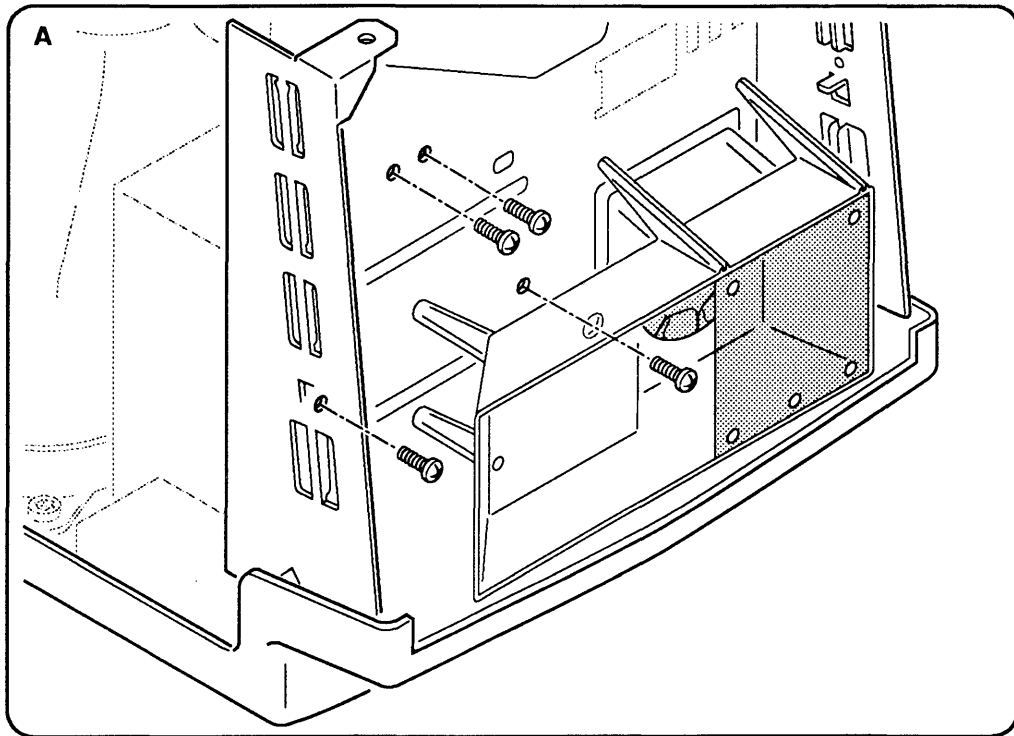

Figure 2-14 Internal 1.4 MB Apple SuperDrive

□ INTERNAL 1.4 MB APPLE SUPERDRIVE

The internal 1.4 MB Apple SuperDrive is in the metal chassis below the SCSI hard disk drive (optional on the Macintosh Classic), as shown in **Figure 2-14**.

Remove

1. Remove the cover and discharge the CRT.
2. After you discharge the CRT, move the computer onto a grounded workbench pad and put on a grounding wriststrap.
3. Remove the memory expansion board (if present) and the SCSI hard disk drive (if present).
4. Remove the main logic board.
5. Place the computer face-down on the workbench pad and remove the four Phillips screws from the chassis bottom (**Figure 2-14A**).
6. Place the computer upright and lift out the Apple SuperDrive mechanism (**Figure 2-14B**).

Replace

1. Remove the dust shield from the Apple SuperDrive.

IMPORTANT: Before you install a replacement 1.4 MB SuperDrive, you **must** remove its dust shield.

2. Place the drive into the chassis so that the tabs on the bottom of the metal drive housing fit into the holes in the chassis frame (**Figure 2-14B**).
3. Holding the Apple SuperDrive in place with one hand, place the computer face-down on the workbench pad with the bottom facing you.
4. Replace the four screws that secure the Apple SuperDrive to the bottom chassis (**Figure 2-14A**).
5. Replace the main logic board.
6. Replace the SCSI hard disk drive and memory expansion board (if you removed them).
7. Replace the cover.

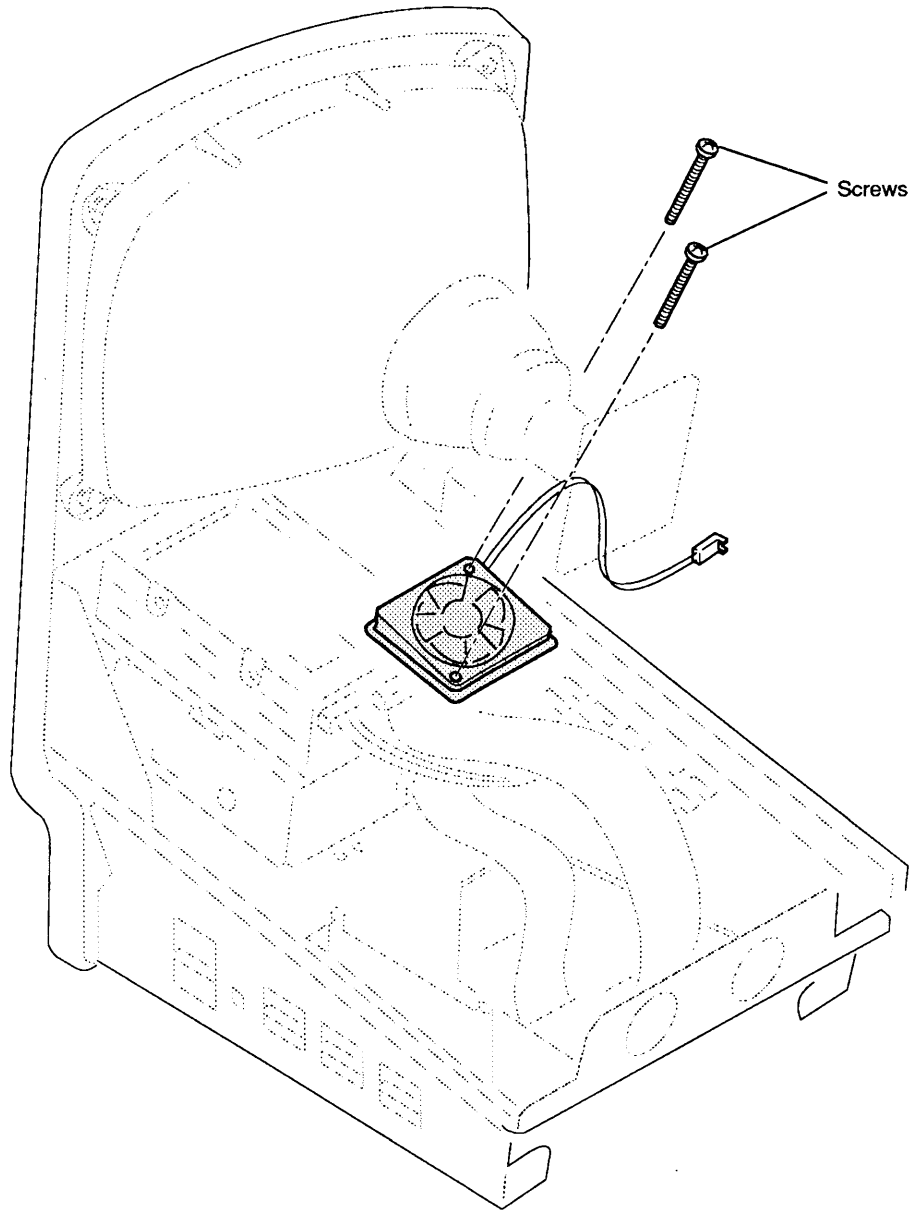

Figure 2-15 Fan

□ FAN

The fan mounts on the bottom chassis between the floppy disk drive and the power/sweep board. You must remove the power/sweep board to reach the fan. Refer to **Figure 2-15**.

Remove

1. Remove the cover and discharge the CRT.
2. Remove the anode cap.
3. Move the computer onto a grounded workbench pad and put on a grounding wriststrap. (Never put on a grounding strap until after you discharge the CRT.)
4. Remove the power/sweep board.
5. Using a small, stump-handled Phillips screwdriver, remove the two screws that mount the fan to the bottom chassis. Lift the fan from the chassis.

Replace

1. Place the fan (label up) in the bottom chassis. Orient the fan so that the fan cable is on the side nearest the outside of the computer. Match the corners of the fan to the screw holes.
2. Use the stump-handled Phillips screwdriver to replace the two mounting screws.
3. Replace the power/sweep board.

Note: Directions for replacing the video board are in the power/sweep board procedure.

4. Replace the anode cap.
5. Replace the cover.

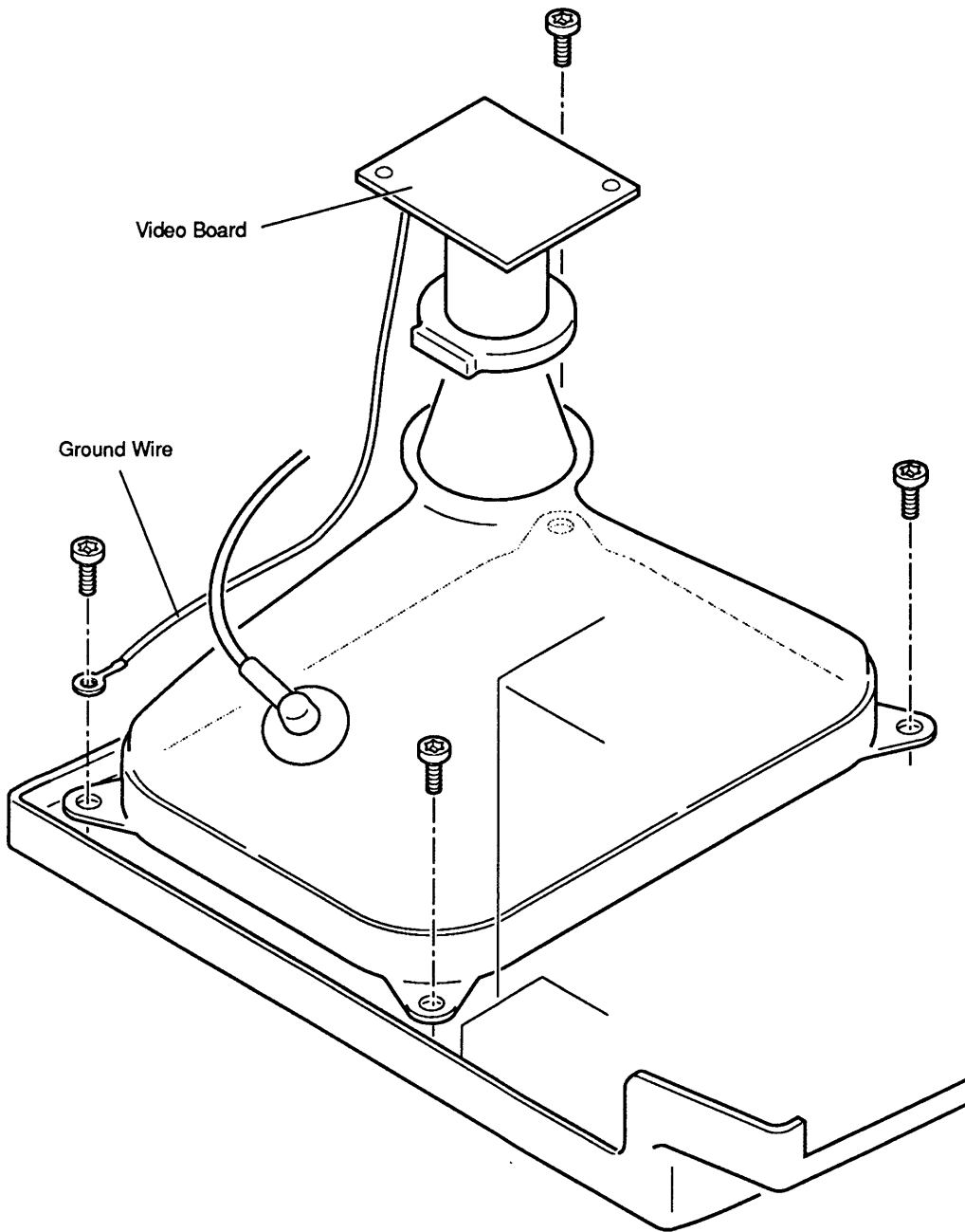

Figure 2-16 Cathode-Ray Tube (CRT)

□ CATHODE-RAY TUBE (CRT)

The cathode-ray tube (CRT) is mounted by four Torx screws to the front bezel. **The cathode-ray tube ships with the yoke assembly installed, so you never have to remove the yoke.**

Note: The CRT yoke assembly is available in two versions, Rev A and Rev B. The CRT yoke assembly must be compatible with the power/sweep assembly, which is also available in Rev A and Rev B models. In other words, CRT yoke assembly Rev A requires power/sweep board Rev A; CRT yoke assembly Rev B requires power/sweep board Rev B.

Refer to "Power/Sweep Board" to identify CRT and power/sweep revisions and to verify compatibility.

WARNING: Before you handle the CRT, be sure you review the precautions given in Section 8, CRT Safety, under the You Oughta Know tab.

Refer to **Figure 2-16** when removing and replacing the CRT.

Remove

1. Remove the cover, discharge the CRT, and remove the anode cap.
2. Move the computer onto a grounded workbench pad and put on a grounding wriststrap. (Never put on a grounding strap until after you discharge the CRT.)
3. Remove the power/sweep board.
4. Place the computer face-down on the workbench pad.
5. Remove the three remaining Torx screws from the corners of the CRT.
6. Carefully lift the CRT free from the bezel.

Replace

1. Place the computer face-down on the workbench pad.
2. Place the CRT face-down in the bezel, with the anode aperture on your left (**Figure 2-16**).
3. Replace the three CRT mounting screws.
4. Replace the power/sweep board. (Refer to **Figure 2-6**, Power/Sweep Board Compatibility, to confirm compatibility with the power/sweep board.)

Note: Directions for replacing the video board and the fourth CRT mounting screw are included in the power/sweep board procedure.

5. Replace the anode cap and the cover.

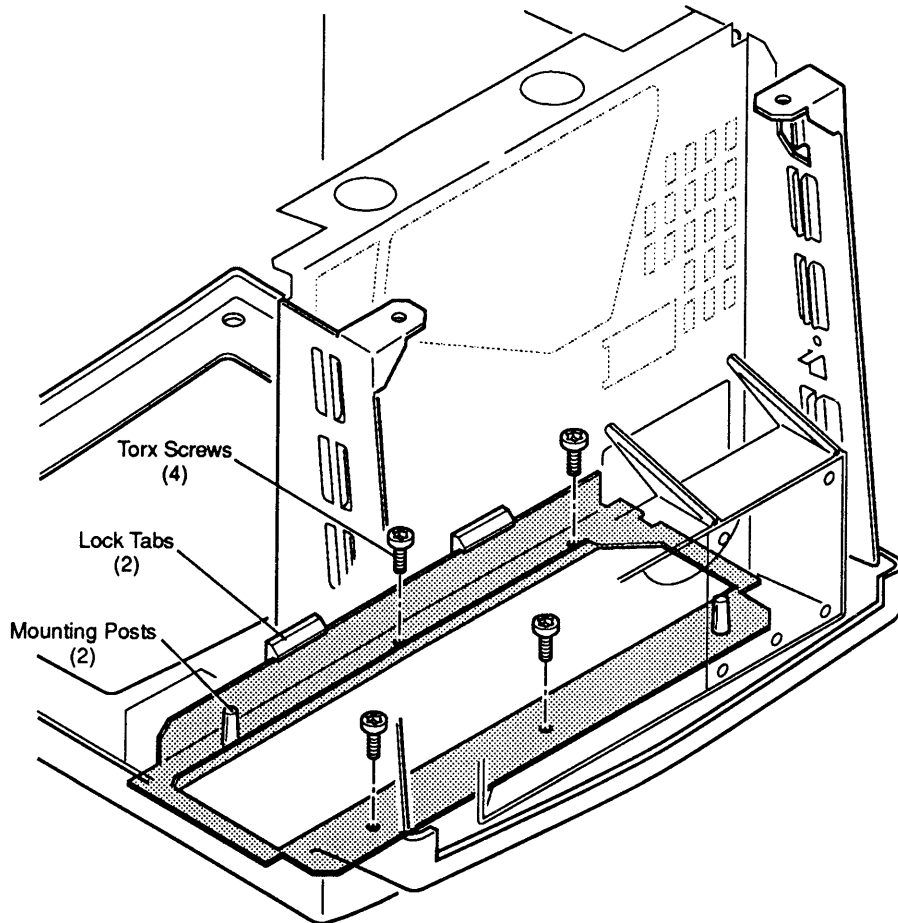

Figure 2-17 Chassis and Front Bezel

□ CHASSIS AND FRONT BEZEL

To replace the metal chassis, you must first remove all assemblies except the CRT. To remove the front bezel, you must remove the chassis and the CRT. Refer to **Figure 2-17** when removing and replacing the chassis and the front bezel.

Remove

1. Remove the cover, discharge the CRT, and remove the anode cap.
2. Move the computer onto a grounded workbench pad and put on a grounding wriststrap. (Never put on a grounding strap until after you discharge the CRT.)
3. Remove the power/sweep board, the memory expansion board (if present), the main logic board, the SCSI hard disk drive (if present), the Apple SuperDrive, and the fan.
4. Remove the four Torx screws and lift out the metal chassis.
5. If you are removing the bezel, first remove the CRT.

Replace

1. Place the bezel face down on the grounded workbench pad.
2. Replace the CRT (if you removed it).
3. Position the metal chassis over the mounting posts on the bezel.
4. Replace the four Torx screws. (Replacement of the screws is much easier if your Torx driver is magnetized.)
5. Replace the fan, the Apple SuperDrive, the SCSI hard disk drive (if you removed one), the main logic board, the memory expansion board (if you removed one), the power/sweep board, the anode cap, and the cover.

□ FUSE

The fuse is on the power/sweep board and is easily reached by removing the Macintosh Classic or Classic II cover. Refer to **Figure 2-18**.

Remove

1. Remove the cover and discharge the CRT.
2. Move the computer onto a grounded workbench pad and put on a grounding wriststrap. (Never put on a grounding strap until after you discharge the CRT.)
3. Using a fuse puller or small flat-blade screwdriver, carefully pry the fuse from its holder.

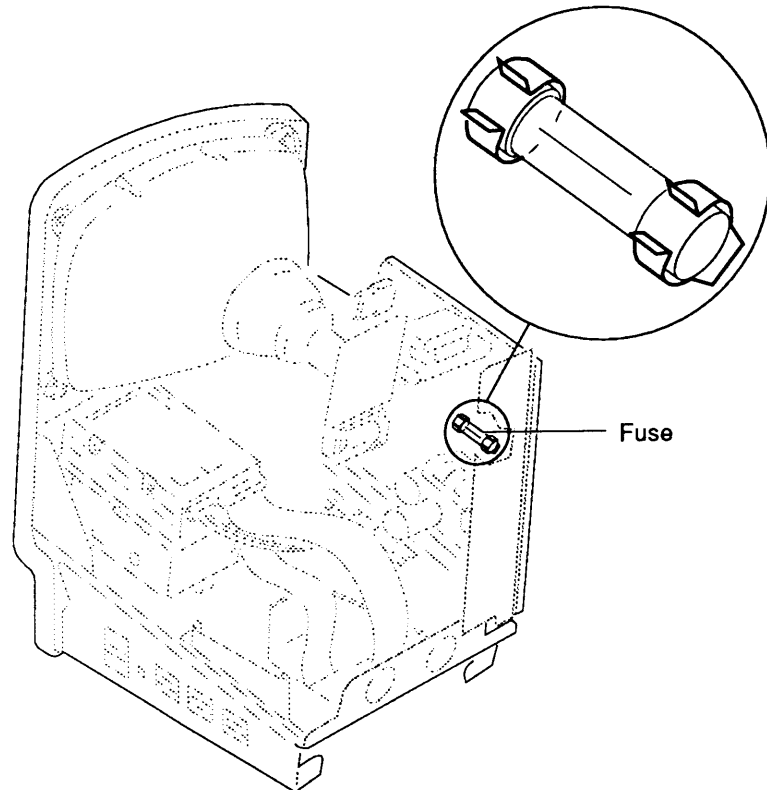

Figure 2-18 Fuse

Replace

1. Snap the replacement fuse into the fuse holder.
2. Replace the cover.

Macintosh Classic and Classic II

Section 3 – Adjustments

□ CONTENTS

- 3.2 Introduction to Adjustments
- 3.3 Exterior (Service Panel) Adjustments
 - 3.3 Introduction
 - 3.3 Materials Required
 - 3.3 Adjustment Setup
- 3.5 Brightness and Contrast Adjustments
- 3.7 Centering Adjustments
 - 3.7 Size Adjustments
 - 3.7 Focus Adjustment
- 3.8 Interior (Yoke) Adjustment
 - 3.8 Introduction
 - 3.9 Materials Required
 - 3.9 Tilt Adjustment

Note: If a step is underlined, detailed instructions for that step are in Section 2, Take-Apart.

□ INTRODUCTION TO ADJUSTMENTS

To adjust the Macintosh Classic, use the *MacTest CL* diagnostic application. To adjust the Macintosh Classic II, use the *MacTest MP* diagnostic application. (Refer to the *Mac Multiple-Product Diagnostics* tab of the *Apple Service Technical Procedures* for more information on *MacTest MP*.)

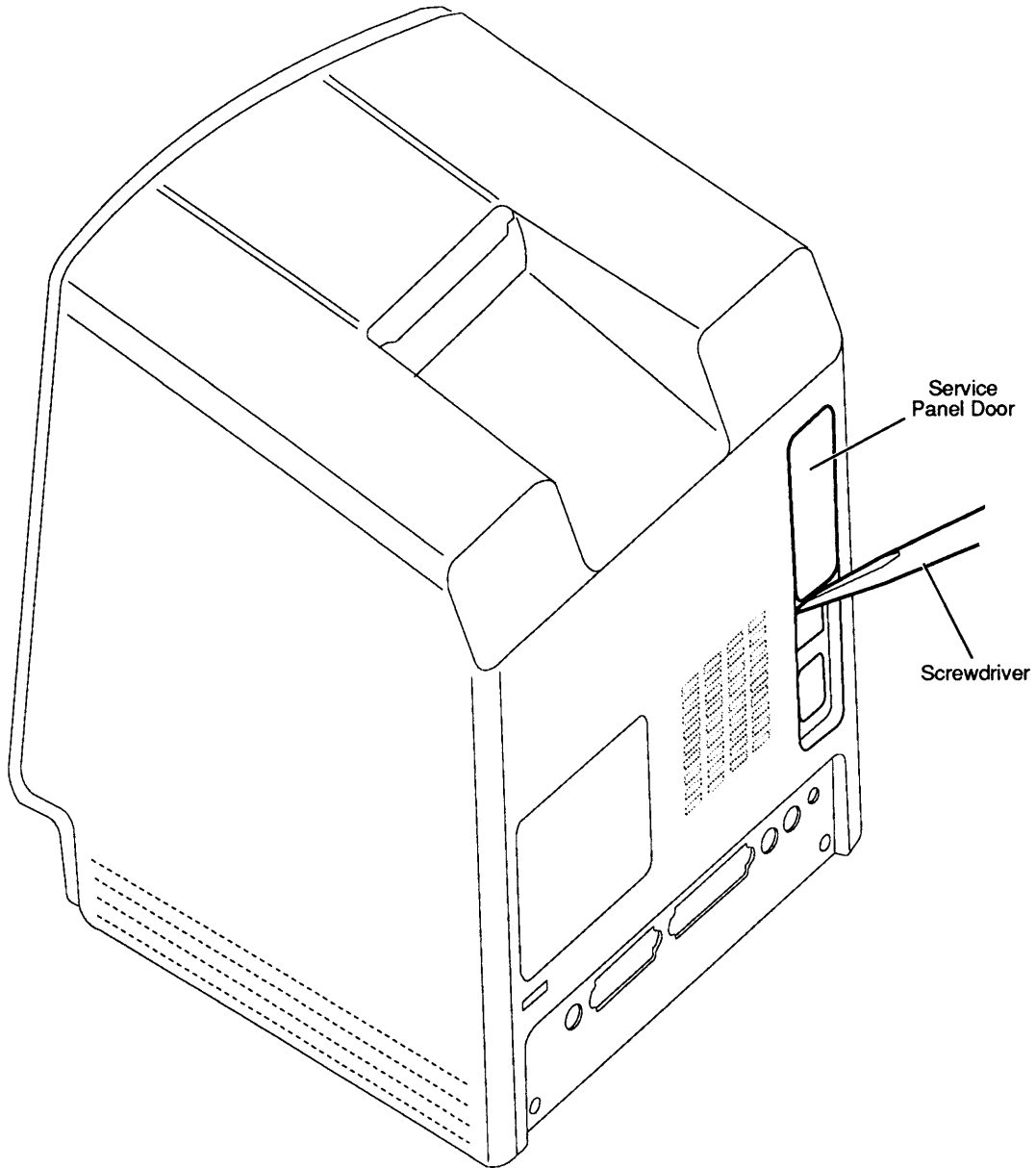

Figure 3-1 Service Panel Door

□ EXTERIOR (SERVICE PANEL) ADJUSTMENTS

Introduction

Video adjustments **may** be necessary whenever you replace the CRT or the power/sweep board. Make video adjustments at the service panel, which is at the back of the computer under the service panel door.

Note: Because the Macintosh Classic and Classic II computers have horizontal and vertical centering pots on the back service panel, you will never have to perform the internal centering ring adjustments that are sometimes necessary on the older Macintosh computers. You need not remove the cover of the computer for any adjustment procedure other than the yoke (tilt) adjustment.

Materials Required

Set of plastic hex alignment tools
Small, insulated, flat-blade screwdriver
Mirror
Ruler
Light meter (Sekonic Multi-Lumi, model L-248)
MacTest CL disk for Macintosh Classic or *MacTest MP*
disk for Macintosh Classic II

Adjustment Setup

1. Remove all metal jewelry. If you are wearing a grounding wriststrap, remove it.
2. Turn the computer so that the rear is facing you, and position the mirror so that you can see the CRT screen.
3. Use a small, flat-blade screwdriver to depress the center tab at the bottom of the service panel door; then lift out the door (**Figure 3-1**).

IMPORTANT: Before performing the following adjustments, make sure the computer has been on for at least 30 minutes.

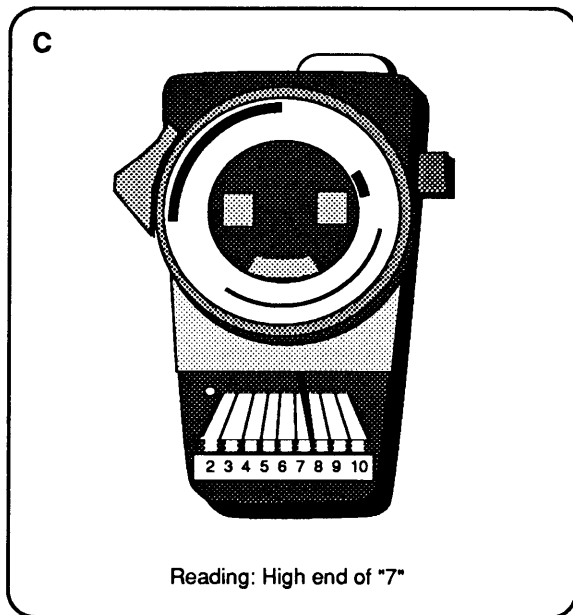
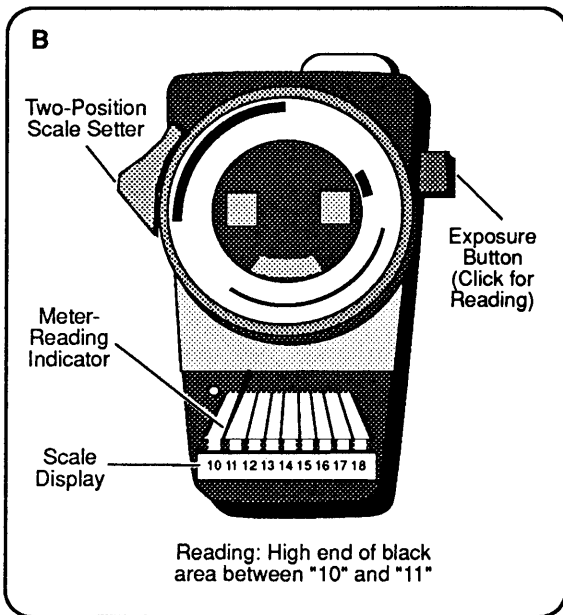
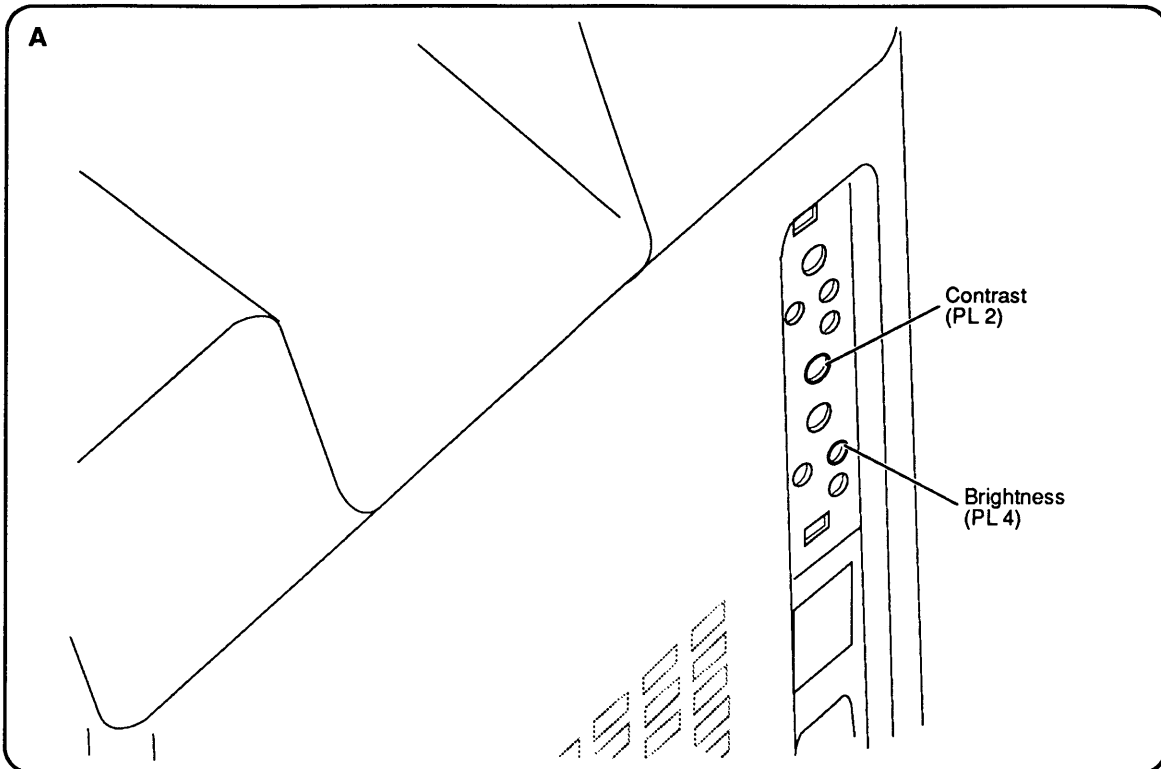

Figure 3-2 Brightness and Contrast Adjustments

Brightness and Contrast Adjustments

1. Be sure the computer has been on for at least 30 minutes.
2. Select **Brightness** from the Adjustments menu in *MacTest CL* or from the Options menu in *MacTest MP*. Click the mouse button once to advance to the first brightness level.
3. Set the light meter scale for the "10 to 18" range (**Figure 3-2B**).
4. Locate the contrast adjustment pot (PL2) on the service panel (**Figure 3-2A**). Using a small, insulated, flat-blade screwdriver or tweaker, adjust the contrast (PL2) so that the luminance at the center of the screen reads at the high end of the black area between "10" and "11" on the light meter scale (**Figure 3-2B**).
5. Click the mouse button to go to the next brightness level.
6. Set the light meter scale for the "2 to 10" range (**Figure 3-2C**).
7. Locate the brightness adjustment pot (PL4) on the service panel (**Figure 3-2A**). Using an appropriately sized plastic hex alignment tool, adjust the brightness (PL4) so that the luminance at the center of the screen reads at the top end of "7" on the light meter scale (**Figure 3-2C**).
8. Click the mouse button again to go to the next brightness level.
9. Reset the light meter scale for the "10 to 18" range and be sure the luminance at the center of the screen reads at the high end of the black area between "10" and "11" on the light meter scale (**Figure 3-2B**). If it does not, repeat steps 2 through 7. (You must go back to the Brightness menu and click the mouse button to advance through the brightness levels again.)

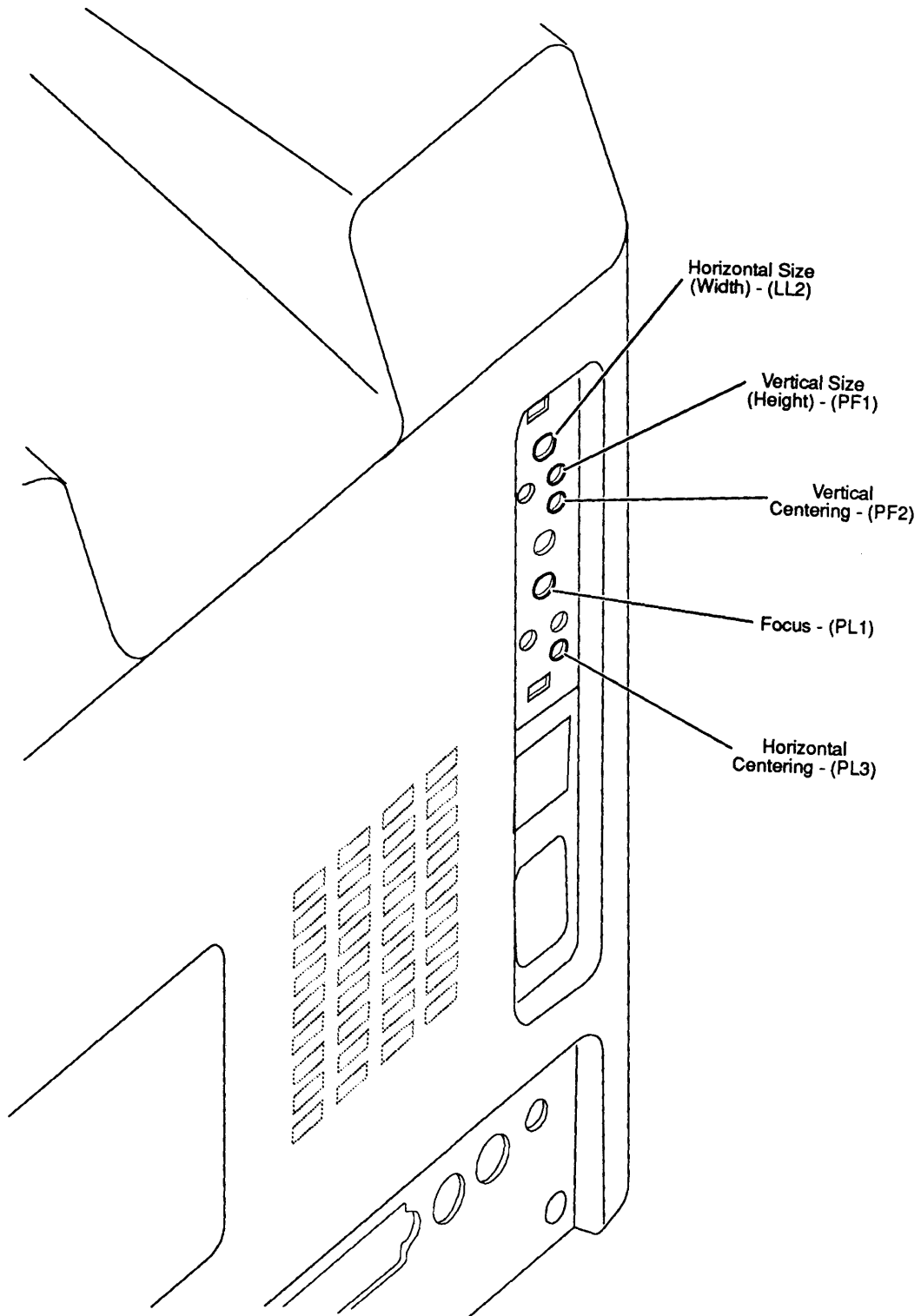

Figure 3-3 Centering, Size, and Focus Adjustments

Refer to **Figure 3-3** when making the following adjustments.

Before beginning, select **Video** from the *MacTest CL* Adjustments menu or select **Screen Patterns** from the *MacTest MP* main menu. Click the mouse button to advance to the pattern indicated for each adjustment below.

Centering Adjustments

1. Select the all-white or crosshatch display (white background). Locate the horizontal centering adjustment pot (PL3) on the service panel. Using a plastic hex alignment tool, adjust PL3 to center the display horizontally within the bezel.
2. Locate the vertical-centering adjustment pot (PF2) on the service panel. Using a plastic hex alignment tool, adjust PF2 to center the picture vertically within the bezel.

Size Adjustments

1. Select the all-white or crosshatch display (white background). Locate the horizontal size adjustment pot (LL2) on the service panel. Using a plastic hex alignment tool, adjust LL2 until the picture is approximately 7 inches wide.
2. Locate the vertical size adjustment pot (PF1) on the service panel. Using a plastic hex alignment tool, adjust PF1 until the picture is approximately 4.7 inches high.

Focus Adjustment

- Select the focus display (the pattern with % signs). Locate the focus adjustment pot (PL1) on the service panel. Using a small, insulated, flat-blade screwdriver or tweaker, adjust PL1 for the best overall focus.

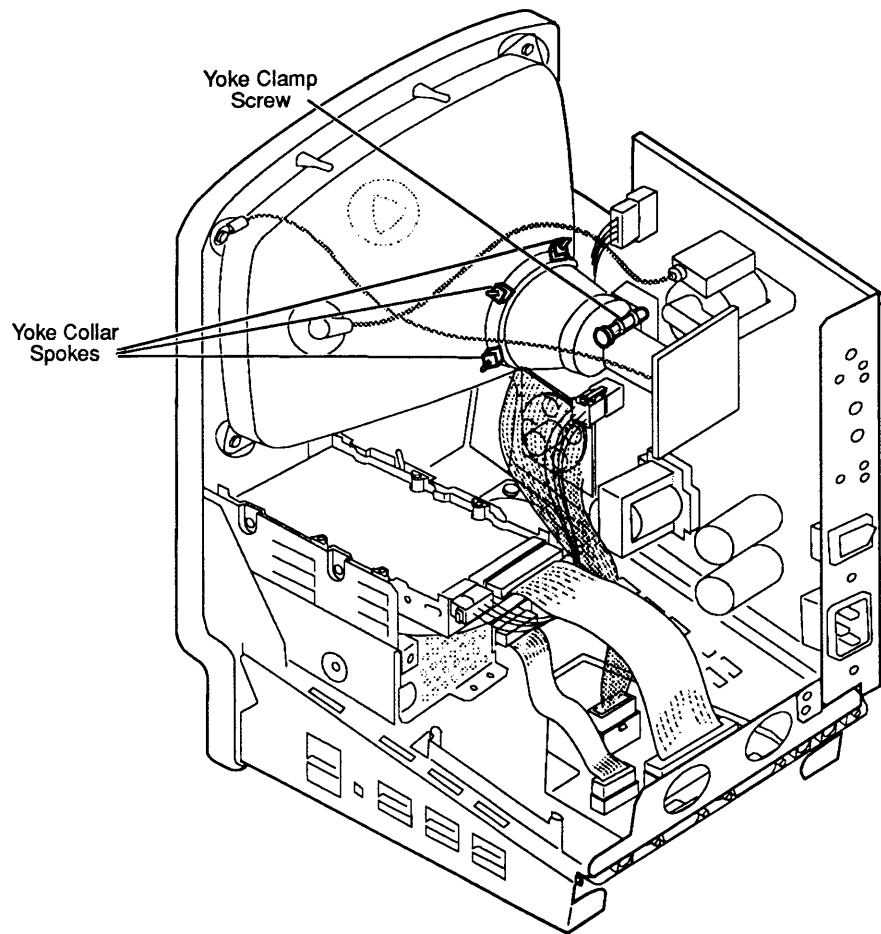

Figure 3-4 Yoke Adjustment

□ INTERIOR (YOKE) ADJUSTMENT

Introduction

In infrequent cases, you may need to adjust the yoke of the computer after you replace the CRT. If the picture is tilted after you have made all possible adjustments from the service panel, you must remove the computer's rear cover and correct the tilt using the yoke adjustment.

Make yoke adjustments while standing behind the computer; position a mirror so that you can see the screen. **Because of the high-voltage danger, do not try to make live adjustments by facing the screen and reaching around the CRT—you can't see what your hands touch!**

Materials Required

Small Phillips screwdriver
Safety goggles
CRT discharge tool (part number **076-0381**)
Soft cloth or foam pad
Mirror
Small art knife

WARNING: Before performing adjustments, refer to Section 8 of the You Oughta Know tab in the Cross Family Peripherals manual. Failure to follow these safety rules could cause serious injury.

Refer to **Figure 3-4** when adjusting the yoke.

Tilt Adjustment

1. Put on safety goggles and remove all metal jewelry. If you are wearing a grounding wriststrap, remove it.
2. Remove the cover and discharge the CRT. (Refer to Section 2, Take-Apart.)
3. Turn the computer so that its rear faces you, and position the mirror so that you can see the CRT screen in the mirror.
4. Loosen the yoke clamp screw at the top of the CRT neck two or three turns.
5. If glue holds the yoke in place, cut the glue with an art knife.
6. Connect the power cord and switch the power on.
7. Put one hand behind your back and, with your other hand, grasp only the plastic spokes of the yoke collar. Rotate the yoke until the top and bottom edges of the picture appear parallel with the top and bottom edges of the bezel.
8. Turn the power off, unplug the computer, and discharge the CRT again.
9. Hold the yoke collar in the position you just determined in step 7. Carefully tighten the yoke clamp screw just enough so that the yoke cannot slip. Do not overtighten.
10. Replace the cover.
11. Connect the power cord and switch the power on. Confirm that the tilt adjustment is still correct.



Macintosh Classic and Classic II

Section 4 – Diagnostics

□ CONTENTS

- 4.2 Introduction to Diagnostics
- 4.2 MacTest CL Overview
- 4.2 Components Tested by MacTest CL
- 4.3 Making Backup Disks
- 4.3 Copying MacTest CL Disks
- 4.4 Running MacTest CL
 - 4.4 Materials Required
 - 4.4 Starting MacTest CL
 - 4.5 Helpful Hints
 - 4.7 Installing the Loopbacks
 - 4.7 Using the MacTest CL Menus
- 4.11 Running the Tests
- 4.13 SCSI Loopback Jumper Procedure
 - 4.13 To Determine Whether You Need a Jumper
 - 4.14 To Install the Jumper

Note: For information on Macintosh Classic II diagnostics, refer to the *Mac Multiple-Product Diagnostics* tab in the *Apple Service Technical Procedures*.

□ INTRODUCTION TO DIAGNOSTICS

Use the *MacTest CL* diagnostic application to test the Macintosh Classic logic board. Use the *MacTest MP* diagnostic application to test the Macintosh Classic II logic board. (For information on *MacTest MP*, refer to the *Mac Multiple-Product Diagnostics* tab in the *Apple Service Technical Procedures*.)

***MacTest CL* does not cover internal SCSI hard disks.** To test these hard disks on the Classic and Classic II computers, use the *Macintosh Hard Disk Drive Diagnostic* disk (see Section 3, Diagnostics, in the *SCSI Hard Disk Drives Technical Procedures*).

This chapter describes the *MacTest CL* program and the Macintosh Classic logic board components it tests.

MacTest CL Overview

MacTest CL is a standalone functional (pass/fail) test of the Macintosh Classic logic board. *MacTest CL* allows you to select the tests you want to run. As each test progresses, messages on the screen indicate which area is under test. As soon as a failure is detected, the test stops and the screen indicates which module to replace. When all modules perform correctly, the test terminates and returns you to the Finder (desktop).

MacTest CL also provides test patterns for use in adjusting the video display.

Components Tested by MacTest CL

MacTest CL tests the following Macintosh Classic system components:

- Main logic board, including:
 - RAM (Random-Access Memory)
 - VIA (Versatile Interface Adaptor)
 - SCC (Serial Communications Chip)
 - ADB (Apple Desktop Bus™) communications
 - Clock
 - Sound chip
- RAM on the memory expansion card
- Video RAM
- SCSI bus
- Internal and external floppy disk drives

□ MAKING BACKUP DISKS

Make a backup of the original *MacTest CL* diagnostic disk before you begin! When testing a defective system, you may damage or erase a section of the *MacTest CL* disk. **You can make backup copies on any Macintosh equipped with an 800K or 1.4 MB disk drive.**

Copying MacTest CL Disks

Use the Finder to make a backup copy of the *MacTest CL* diagnostic disk. Be sure to **copy the entire disk** and not just the *MacTest CL* program. The *MacTest CL* disk contains specific versions of the System and Finder, and may not run with other versions. **Copy *MacTest CL* to 800K or 1.4 MB disks.**

Using Your Backup Disk

Take the following precautions when using your *MacTest CL* disk copy:

- **Do not write-protect your working copy of the *MacTest CL* disk.** The program will not run correctly if you do.
- **Do not replace the System or Finder on the *MacTest* disk.** The versions on the disk are System 6.0.7 and Finder 6.1.7. *MacTest CL* may not work with other versions of the System and Finder.
- **Do not change the name of the diagnostic program on the disk.** During logic board testing, the machine reboots, looks for, and restarts the diagnostic named *MacTest CL*. If you change the name, the startup routine cannot locate the program, and the system will stay on the desktop.

If the *MacTest CL* window does not reappear after a logic board test, check the name of the diagnostic icon on the desktop. Correct the name to read *MacTest CL* and select **Set Startup** from the desktop Special menu. When the **Set Startup** dialog box asks if you wish to change the name of the startup application to *MacTest CL*, click **OK**. Double-click on the corrected *MacTest CL* icon to return to the test program.

□ RUNNING MACTEST CL

Materials Required

MacTest CL diagnostic disk (backup)
Mini-DIN-8-to-mini-DIN-8 serial port cable
SCSI loopback test card (modified with jumper—see "SCSI Loopback Jumper Procedure")
Blank 1.4 MB disk
Blank 800K disk
Macintosh Classic computer

Starting MacTest CL

You can use *MacTest CL* to perform a functional test of the entire system, or you can use it to test a single component in a known-good system. Follow the start-up steps below for the testing you wish to perform.

Testing Complete System or Logic Board

1. If you are testing a complete system, or if you intend to run the logic tests, turn the power off and install the loopback connectors as described under "Installing the Loopbacks," later in this section.
2. Insert the *MacTest CL* disk into the internal drive, and switch on the system. *MacTest CL* will display the Start, or Status, window.
 - If you want to run only the short logic board tests, click **Start**. (The short logic board test is the default test selection.)

- If you want to run the long logic board tests (or if you want to add other tests), first go to the Options menu and use the Test Selections submenu to select the tests you want to run. Then click **Start** to run the tests. (For more-specific information on the tests, see "Using the *MacTest CL* Menus" and "Running the Tests," later in this section.)

Testing Single Component

1. If you are testing a single component (other than the logic board) in an otherwise known-good system, insert the *MacTest CL* disk into the internal drive and switch on system power.
2. From the Status window, go to the Options menu and use the Test Selections submenu to select the tests you want to run. Then click **Start**. (For more-specific information on the tests, see "Using the *MacTest CL* Menus" and "Running the Tests," later in this section.)

Helpful Hints

- The *MacTest CL* logic board tests check all the logic in the system—on the main board, on the memory expansion board, and on the SIMMs; however, the diagnostic does not identify which of these modules has failed the tests. Follow the steps below to determine which logic module has failed:
 - a) If the system fails the logic tests, remove the memory expansion board and run the logic tests again. If the tests fail, replace the main logic board. If the tests pass, go to step b.
 - b) Install the customer's memory expansion board (without SIMMs) and run the logic tests again. If the tests fail, replace the memory expansion board. If the tests pass, go to step c.
 - c) Install a known-good SIMM in one SIMM connector and one of the customer's SIMMs in the other connector. Run the logic tests again. If the tests fail, replace the customer's bad SIMM. If the tests pass, the customer's *other* SIMM is bad and must be replaced.
 - d) Run the logic tests again as verification of the repair.

- If you encounter any of these problems, try the solution that follows each problem:
 - **A known-good MacTest CL disk will not boot:** Refer to Section 5, Troubleshooting.
 - **The Configuration window indicates that an attached disk drive is not installed:** Check the disk drive cables.
 - **The Configuration window indicates that the wrong amount of RAM is installed:** Check the memory expansion board for secure SIMM placement in the SIMM connectors and for correct positioning of the jumper. (Refer to Section 2, Take-Apart.)

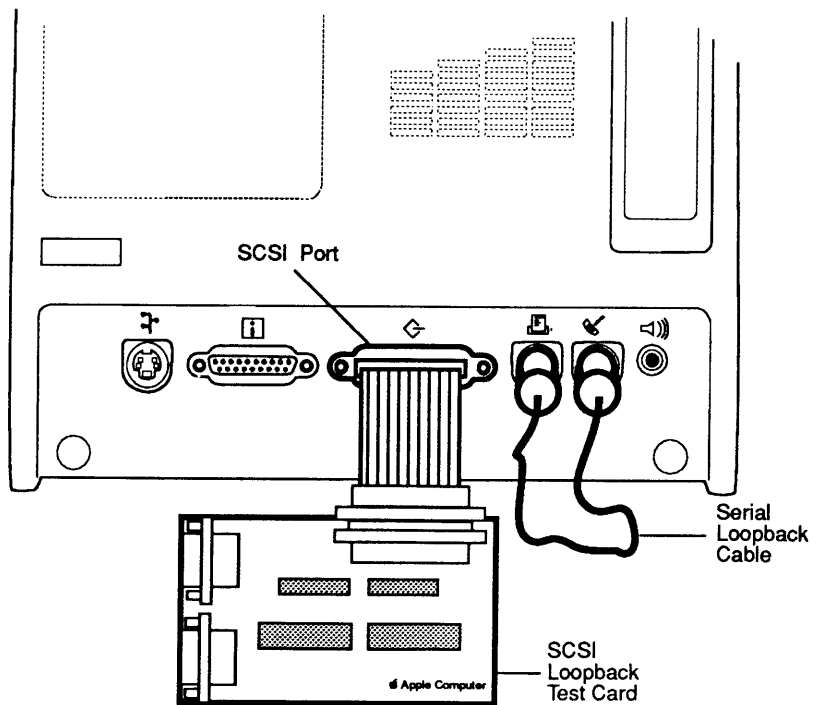

Figure 4-1 Installing the Loopbacks

Installing the Loopbacks

Before beginning *MacTest CL* and **with the power off**, connect the serial loopback cable and the SCSI loopback card (as directed below), the keyboard and mouse, and the external drive (optional).

CAUTION: Always switch off the system before you connect or disconnect the SCSI loopback card.

Refer to **Figure 4-1** when installing the SCSI loopback card and the serial loopback cable.

1. Connect the SCSI loopback card to the SCSI port on the back of the system. (No other connections between the card and the Macintosh are necessary.) To protect the SCSI circuitry, you must have the power off when you connect the SCSI card.

Note: When the SCSI loopback card is connected, the internal SCSI hard disk will not be able to respond, nor will it be recognized by the system.

2. Install the mini-DIN-8-to-mini-DIN-8 serial port (loopback) cable between the modem and printer ports on the rear of the machine.

Using the MacTest CL Menus

Before you start running *MacTest CL*, you can use the *MacTest CL* menus to select the tests that you want to run or to select other features of the diagnostic. **You cannot use the menus when the tests are running.**

Options Menu

The Options menu contains the Test Selections and Configuration submenus.

1. **Test Selections.** To select a test, click the box next to the name of the item to be tested (an **X** appears). To deselect the test, click the box again (the **X** disappears). When you have selected all the tests you wish, click **OK** to return to the *MacTest CL* Status window.

a) **Logic Board.** This test verifies the correct functioning of the following circuitry on the logic board:

- VIA (Versatile Interface Adaptor)
- SCC (Serial Communications Controller)
- Clock
- SCSI bus
- RAM

Note: When the Logic Board RAM test fails in looping mode, the test stops and displays a failure message. When you click **OK** to continue the test, however, the test continues as if no failure had occurred and concludes with the message, "All selected tests have passed." The test has truly discovered a failure as indicated by the first failure message. Follow the procedures in the failure message.

You can select a short or lengthy logic test. The running time of the test depends on how much memory is installed. At the beginning of the RAM test, *MacTest CL* indicates the maximum running time of the test. The lengthy logic test selection also tests the 64K of video RAM. Be aware that video patterns will flash across your screen during this test.

b) **Sound.** This option provides two tests that verify the proper functioning of the sound chip:

- **8-Level Volume Test:** produces eight tones of increasing volume.
- **C Scale:** produces a C-major scale.

c) **Disk Drives.** You can test any or all of the floppy disk drives (except an external floppy disk drive that is connected through a non-SCSI Hard Disk 20).

Note: *MacTest CL* does not test any hard disk drives.

- d) **Loop on selected tests.** This selection provides a continuous running (in sequence) of all selected tests. To stop the looping, click **Stop** between tests (that is, when the screen displays an arrow rather than a wristwatch).

Here are a few simple guidelines to keep in mind when preparing to perform loop tests:

- You cannot loop on *both* the Logic Board and Disk Drives tests at the same time.
- When loop-testing a disk drive with more than one possible data format (FDHD), you can select only one format.

2. **Configuration.** The *MacTest CL* Configuration window indicates the amount of memory in the Macintosh, the version number of the ROMs, the type of disk controller chip installed, and the current disk drive configuration.

Adjustments Menu

The Adjustments menu offers the following selections:

1. **Video.** By clicking the mouse, you will advance through a series of video test patterns. After making any necessary video adjustments, click the mouse to continue through the test patterns and return to the *MacTest CL* window.
2. **Brightness.** By clicking the mouse, you will advance through a series of video brightness intensities that can be used to adjust the video brightness setting. Continue clicking on the mouse to return to the *MacTest CL* window.

Note: You cannot loop on Video Adjustments.

File Menu

The File menu displays the following items. (**Open** and **Close** are dimmed.)

- **Open...** [Command-O]
- **Close** (Dimmed unless a desk accessory is open)
- **Save Test Selections** [Command-S]
- **Stop** [Command-.]
- **Quit** [Command-Q]

1. **Save Test Selections:** Allows you to customize your *MacTest CL* disk by saving your selection of tests for the next time you use *MacTest CL*.
2. **Stop:** Ends the diagnostic and returns to the *MacTest CL* Status window.
3. **Quit:** Returns you to the desktop.

Apple Menu

The Apple (🍏) menu contains the following items. (**Chooser** and **Find File** are shown, but they are inactive.)

1. **About MacTest™ CL.** When selected, a dialog box displays the diagnostic name, version number, date of release, serial number, and a copy-protect statement.
2. **Control Panel.** This option allows you to set preferences for speaker volume, monitor status, mouse tracking, or desktop pattern.
3. **Key Caps.** When selected, **Key Caps** displays a window with a keyboard. Press each key on the keyboard and verify that the display block for the key is highlighted. If the key is not highlighted, the keyswitch is bad and should be replaced. If numerous keys are not highlighted, exchange the keyboard.

Running the Tests

After using the Test Selections menu to select the tests you wish to run, you are ready to start *MacTest CL*. Click **Start** in the Status window. Please note the following:

- The Status line at the bottom of the window will keep you informed of the tests being performed and the test results.
- While running, all tests display a wristwatch. There is no other moving or flashing indicator that tells you the test is in progress.

CAUTION: *Do not press the reset or interrupt switch while the RAM test is running. Pushing reset causes the RAM test to fail, and pressing interrupt may damage the MacTest CL disk.*

- You may halt the testing by clicking **Stop** or **Pause** anytime *between* tests (when the cursor is an arrow, rather than the wristwatch).
 - Choose **Stop** to halt the testing and to return to the Status window. Choose **Start** when you wish to begin the testing sequence again.
 - Choose **Pause** if you wish to discontinue testing temporarily. Choose **Continue** to resume the tests from the point of interruption.

Note: **Pause**, the default option, can also be selected **during** testing by pressing the <Enter> or <Return> keys. The program will act upon the Pause command when it is between tests.

- When testing the logic board with a SCSI loopback card that is missing or improperly installed, testing will begin but the SCSI port test will fail. If you wish to test the SCSI port, you must switch off system power, disconnect all external SCSI drives, and connect the SCSI loopback card before continuing the test. *MacTest CL* permits bypassing this test.

- When testing the logic board, if the serial loopback cable is missing or improperly installed, the testing will begin but the serial ports test will fail. You will be instructed to connect a serial loopback cable and then to click **OK** to retry the failed test. (You can connect the serial loopback cable without shutting down the system.) *MacTest CL* permits bypassing this test.
- When you select the long logic board test, the RAM test displays several seconds of graphics before the program reboots to the *MacTest CL* Status window.
- When testing the Apple SuperDrive, you will be prompted to insert and remove a high-density (1.4 MB) disk. Perform the disk swap as directed on the screen.

Note: It is important to insert the requested high-density disk. If you insert the wrong disk, *MacTest CL* will indicate that the disk drive is malfunctioning when it may not be.

Replace any module that the test indicates is faulty (see Section 2, Take-Apart). Before replacing the module, refer to Section 5, Troubleshooting, to verify the diagnosis. After replacing the module, run *MacTest CL* again as a confidence test.

If all tests pass, *MacTest* returns to the Status window. The message **All selected tests have passed** appears on the Status line.

Note: If the Logic Board RAM test fails in looping mode, a failure message appears, but the test continues. "All selected tests have passed" appears despite the failure. The test has truly discovered a failure. Follow the procedures in the failure message.

□ SCSI LOOPBACK JUMPER PROCEDURE

To Determine Whether You Need a Jumper

To be used with *MacTest CL*, the SCSI loopback card must be jumpered between Pin 25 of J1 and Pin 14 of RP1. On newer SCSI loopback cards, the jumper is etched into the printed circuit. Only cards with the older PCB artwork need the jumper procedure.

Note: This modification does not interfere with the card's use on other Macintosh or Apple II family systems, except that to work on Apple II systems, the card must be connected to a notched mouse cable. (For further information on the notched cable, refer to *Apple II Family Cards*, Section 1, "SCSI Interface Card and High-Speed SCSI Interface Card.")

To Identify a Newer Card

To determine whether you have a newer card, which will not need to be jumpered, look at the back of the card. If the jumper is included in the artwork, there will be an **A** instead of double zeros (**00**) at the end of the part number, which is located under the words "APPLE COMPUTER" (Figure 4-2). **These newer cards do not have to be jumpered.**

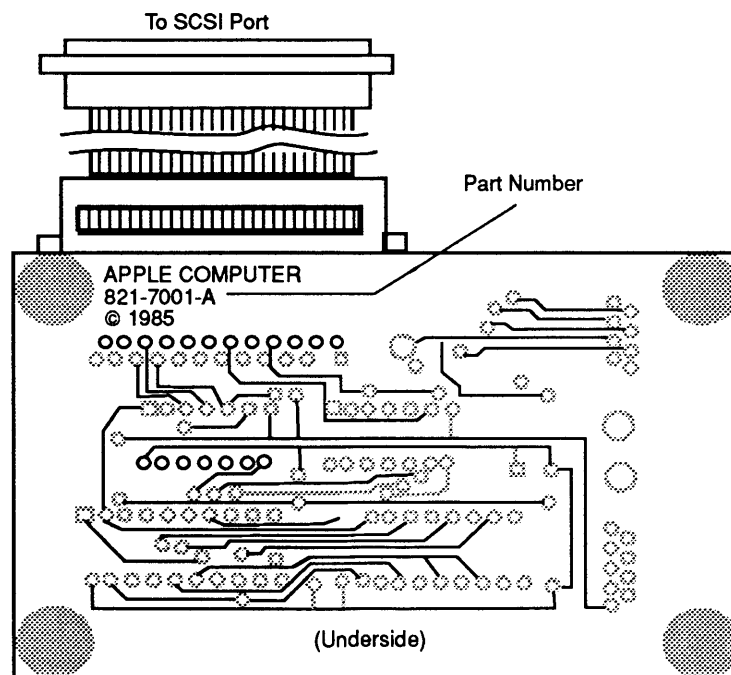

Figure 4-2 Identifying a Newer Card

*External
Jumpers on
Older Cards*

Some cards with the **00** part number and the older artwork were modified with an external jumper during the manufacturing process. Therefore, if your card has a **00** part number, check to see if it has an external jumper from Pin 25 of J1 to Pin 14 of RP1 (**Figure 4-3**). If the card has no external jumper, you must install one yourself.

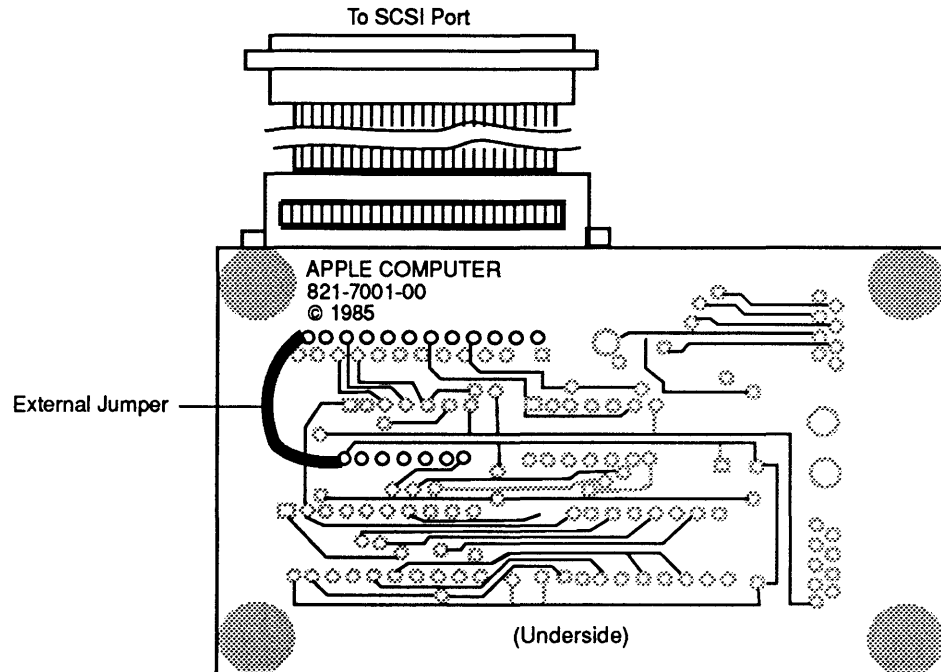

Figure 4-3 Identifying an Older Card

Summary

To summarize:

**If # on back
ends with:**

A

00

Do this:

Nothing

(Jumper is present in artwork.)

Check to see if external jumper
is present. If not, install jumper.

**To Install
the Jumper**

If you find that the card must be jumpered, solder a wire connection between Pin 25 of J1 and Pin 14 of RP1, as shown in **Figure 4-3**. (The pins are not numbered on the board. In the orientation shown in **Figure 4-3**, Pin 25 is the pin closest to the upper-left corner of the card, and Pin 14 is in the middle line of pins, closest to the left edge of the card.)

Macintosh Classic and Classic II

Section 5 – Troubleshooting

□ CONTENTS

5.3	Introduction
5.3	General Information
5.3	How to Use the Symptom Chart
5.3	Things to Remember
5.5	Battery Verification
5.5	Introduction
5.5	Materials Required
5.5	Verification Procedure
5.6	Symptom Chart
5.6	Video Problems
5.7	Peripheral Problems
5.8	Floppy Drive Problems
5.9	SCSI Problems
5.10	Miscellaneous Problems

Note: Detailed instructions for underlined steps are in Section 2, Take-Apart.



□ INTRODUCTION

General Information

You can use the following three diagnostic tests to troubleshoot a Macintosh Classic and/or Classic II system:

- **MacTest CL (Macintosh Classic only)** - refer to Section 4, *Diagnostics*, under this tab for instructions.
- **MacTest MP (Macintosh Classic II only)** - refer to the *Macintosh Multiple-Product Diagnostics* tab in the *Apple Service Technical Procedures*.
- **Macintosh Hard Disk Drive Diagnostic (version 4.0 or higher)** - refer to Section 3, *Diagnostics*, in the *SCSI Hard Disk Drives Technical Procedures* for instructions.

Use this troubleshooting section if the diagnostics are unable to detect a failure. Read the symptom chart and the battery verification procedure before you begin.

You will need this information to effectively troubleshoot the computer. After repairing the system, run the diagnostics again to verify system operation.

How to Use the Symptom Chart

Find the symptom that most nearly describes the problem; then perform the corrective actions in the order listed. If a corrective action does not fix the problem, go to the next action. **If you replace a module and find that the problem remains, reinstall the original module before you go on to the next action.**

Things to Remember

Always be sure to:

- Read all the CRT safety precautions before removing or installing any modules and follow all ESD precautions when troubleshooting. (See the *You Oughta Know* tab for more information.)
- **Discharge the CRT** before removing or installing any modules. (See Section 2, *Take-Apart*.)
- Use known-good software. Bad software can produce symptoms that appear to be hardware problems.

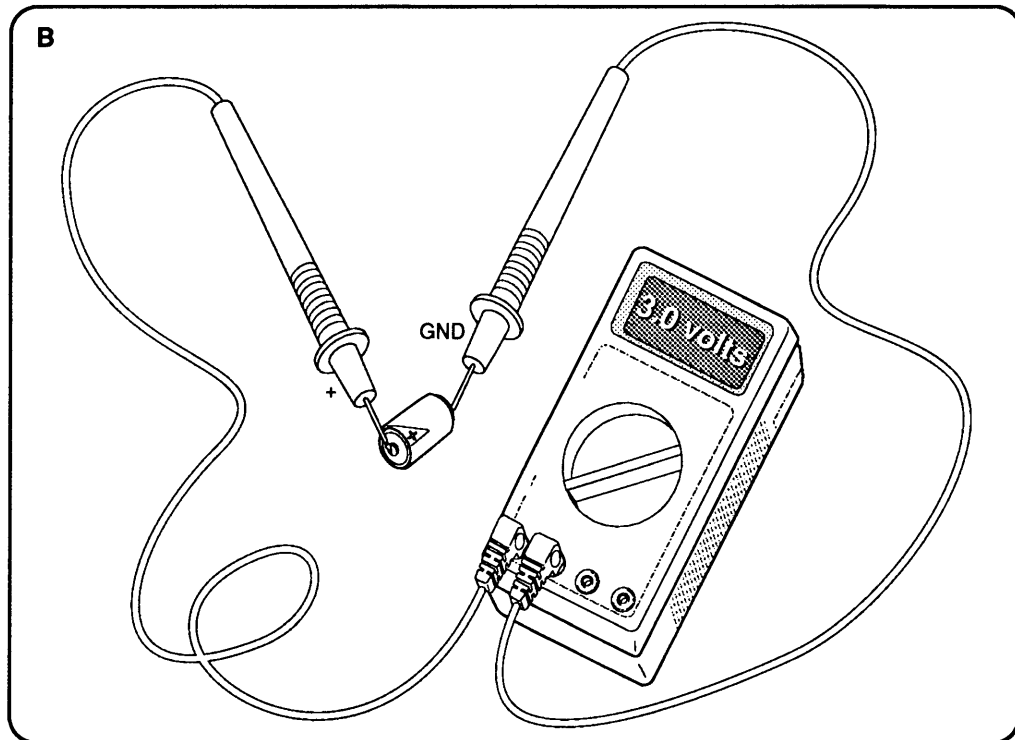
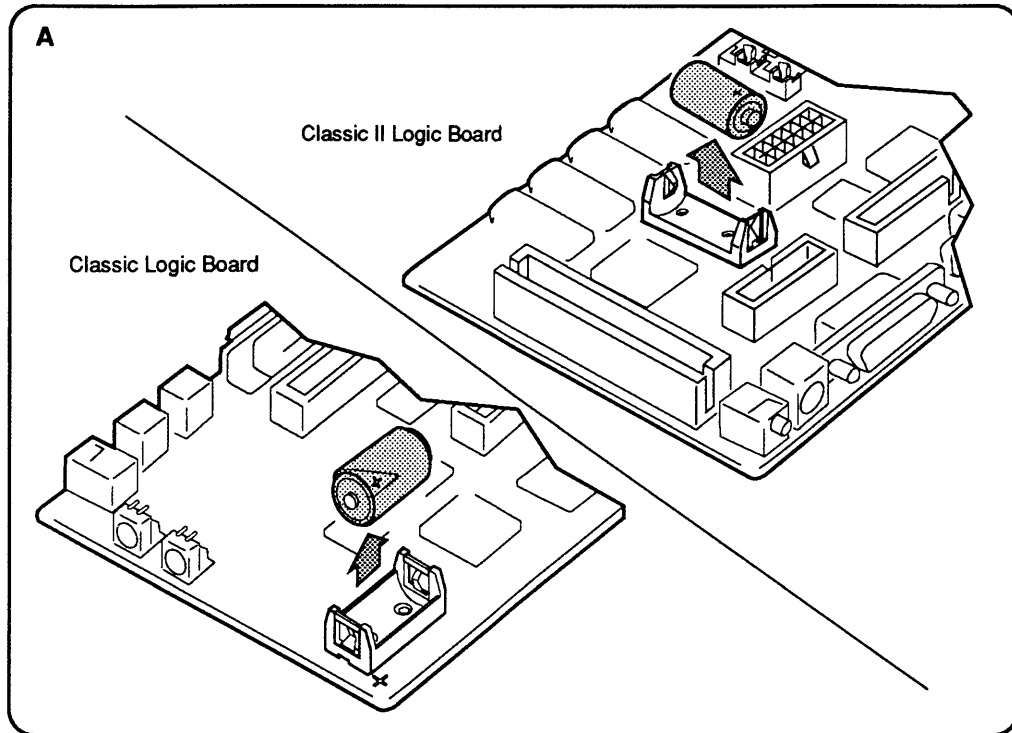

Figure 5-1 Battery Verification

□ BATTERY VERIFICATION

Introduction

Use the following procedure to check the operation of the lithium battery. If the battery falls below specifications, replace it. Refer to Section 6, Additional Procedures, for replacement information.

WARNING: *Lithium batteries, the type in the Macintosh Classic and Classic II, have a potential for explosion if improperly handled. Follow the procedure below exactly.*

Materials Required

Voltmeter

Verification Procedure

1. Switch the power off and disconnect the AC power cable.
2. Remove the cover and discharge the CRT.
3. After you discharge the CRT, move the computer onto a grounded workbench pad and put on a grounding wriststrap.
4. Remove the main logic board.
5. Locate the lithium battery. The battery in the computer is in a plastic battery holder. To measure battery voltage (**Figure 5-1A**), you may have to pull out the battery.
6. Set the voltmeter range to measure 10 volts DC.
7. Touch and hold the **positive probe** of the voltmeter to the **positive side** of the battery (**Figure 5-1B**). (The positive side of the battery is marked +.)
8. Touch and hold the **ground probe** of the voltmeter to the **negative side** of the battery (**Figure 5-1B**).

The reading for a good battery should be **3.0 volts or higher**. **If the battery voltage is below 3.0 volts, replace the battery.** To replace the battery, refer to Section 6, Additional Procedures.

□ SYMPTOM CHART

Video Problems

Solutions

- *Screen is dark; audio and drive operate*
 1. Readjust brightness (see Section 3, Adjustments).
 2. Readjust cutoff (see Section 3, Adjustments).
 3. Check yoke cable connection.
 4. Replace power/sweep board.
 5. Replace main logic board.
 6. Replace CRT.

- *Screen is bright and audio is present, but no video information is visible*
 1. Replace power/sweep board.
 2. Replace main logic board.

- *Screen is dark; fan is not running*
 - Replace power/sweep board.

- *Screen displays single vertical or horizontal line*
 1. Replace power/sweep board.
 2. Replace main logic board.
 3. Replace CRT.

- *Screen displays vertical or horizontal bars or stripes*
 1. Replace power/sweep board.
 2. Replace main logic board.

- *Screen displays white dot in center of screen*
 1. Verify that the yoke cable is connected.
 2. Replace power/sweep board.
 3. Replace CRT.

- *Screen jitters*
 1. Move computer away from adjacent monitors or other electrical equipment that may cause interference.
 2. Replace power/sweep board.

Peripheral Problems

Solutions

- *Cursor does not move*
 1. Check mouse connection.
 2. If mouse was connected to keyboard, connect it to a rear ADB port instead. If mouse works, replace keyboard. If mouse does not work in any ADB port, replace mouse.
 3. Replace main logic board.

- *Cursor moves, but clicking the mouse button has no effect*
 1. Replace mouse.
 2. Replace main logic board.

- *Cannot double-click to open an application, disk, or server*
 1. Remove extra system files on the hard disk.
 2. Clear parameter RAM. Hold down the <Shift><Option><Command> keys and select Control Panel from the Apple pull-down menu. Reset mouse controls.
 3. If mouse was connected to keyboard, connect it to rear ADB port instead. If mouse works, replace keyboard. If mouse does not work in ADB port, replace mouse.
 4. Replace main logic board.

- *No response to any key on the keyboard*
 1. Check keyboard connection to ADB port.
 2. Replace keyboard cable.
 3. Replace keyboard.
 4. Replace main logic board.

- *Known-good ImageWriter or ImageWriter II will not print*
 1. Make sure that Chooser and Control Panel are set correctly.
 2. Replace printer driver and system software with known-good driver and system software.
 3. Replace printer interface cable.
 4. Replace logic board.

- *Known-good LaserWriter will not print*
 1. Make sure that Chooser and Control Panel are set correctly.
 2. Replace printer driver and system software with known-good driver and system software.
 3. Refer to the *Networks* tab in the *Apple Service Technical Procedures*.

Floppy Drive Problems

Solutions

- *Audio and video are present, but internal drive does not operate*
 1. Replace bad floppy disk with known-good disk.
 2. Replace internal disk drive cable.
 3. Replace internal disk drive.
 4. Replace main logic board.

- *External drive does not operate*
 1. Replace bad floppy disk with known-good disk.
 2. As you face the computer screen, be sure the external drive is placed to the right side of the computer.
 3. Replace external drive.
 4. Replace main logic board.

- *Disk ejects; display shows icon with blinking "X"*
 1. Replace bad floppy disk with known-good system disk.
 2. Replace disk drive.
 3. Replace main logic board.

- *Unable to insert disk all the way*
 1. Insert opened paper clip into hole beside the drive to remove a previously inserted disk.
 2. Switch off system. To complete eject cycle, hold mouse button down while switching on the computer. Remove floppy disk.
 3. Replace disk drive.

- *Will not eject disk*
 1. Insert opened paper clip into hole beside the drive.
 2. Switch off system. To complete eject cycle, hold mouse button down while switching on the computer. Remove floppy disk.
 3. Replace disk drive.

- *Internal disk drive runs continuously*
 1. Replace bad floppy disk with known-good disk.
 2. Replace disk drive.
 3. Replace main logic board.
 4. Replace disk drive cable.

SCSI Problems

Solutions

- *Internal or external hard disk will not operate*
 1. Verify that SCSI loopback card is not attached.
 2. Check that internal SCSI terminator is positioned in the connector properly (noninternal hard drive systems only).
 3. Verify that all three internal hard drive terminators are on the circuit board (internal hard drive systems only).
 4. Replace hard disk drive cable.
 5. Replace hard disk.
 6. Replace main logic board.

- *Works with internal or external SCSI device but will not work with both*
 1. Verify that SCSI device ID switch setting on external device is 1, 2, 3, 4, 5, or 6. Verify that ID switch setting on external SCSI device does not duplicate ID switch settings on any other attached external SCSI devices.
 2. Replace terminator on external SCSI device.
 3. Verify that terminator resistors are installed on the internal SCSI drive.
 4. Replace SCSI device select cable.

Miscellaneous Problems

Solutions

- *Clicking, chirping, or thumping sound*
 1. Verify that main logic board power cable is connected at J12 on the main logic board.
 2. Replace power/sweep board.
 3. Replace main logic board.

- *Smoke/odor*
 - Replace power/sweep board.

- *No video, no audio, and no drive operation*
 1. Connect power cord.
 2. Switch power on.
 3. Replace power cord.
 4. Replace power/sweep board.
 5. Replace main logic board.

- *"Sad Macintosh" icon*
 1. Replace bad floppy disk with known-good disk.
 2. Verify that jumper on memory expansion board is configured correctly for "SIMMs" or "No SIMMs" (Macintosh Classic only—see Section 2, Take-Apart).
 3. On the Macintosh Classic, replace optional memory expansion board; On the Macintosh Classic II, replace optional SIMMs in the two SIMM slots on main logic board.
 4. Replace main logic board.

- *Screen shows "Sad Macintosh" icon and black vertical lines; screeching sound*
 1. Verify that jumper on memory expansion board is configured correctly for "SIMMs" or "No SIMMs" (Macintosh Classic only—see Section 2, Take-Apart).
 2. On Macintosh Classic, replace optional memory expansion board; On Macintosh Classic II, replace optional SIMMs installed in the two SIMM slots on main logic board.
 3. Replace main logic board.

Macintosh Classic and Classic II

Section 6 – Additional Procedures

□ CONTENTS

6.2	SIMM Upgrades – Macintosh Classic
6.2	RAM Configurations
6.2	SIMM Identification
6.2	Installing Upgrades
6.3	SIMM Upgrades – Macintosh Classic II
6.3	RAM Configurations
6.3	SIMM Identification
6.3	Installing Upgrades
6.4	Battery Replacement
6.4	Introduction
6.5	Replacement Procedure
6.6	Macintosh Classic II Upgrade
6.6	Introduction
6.6	Upgrade Procedure

Note: If a step is underlined, detailed instructions for that step can be found in Section 2, Take-Apart.

□ SIMM UPGRADES – MACINTOSH CLASSIC

RAM Configurations

The Macintosh Classic can have 1 MB, 2 MB, 2.5 MB, or 4 MB of random-access memory (RAM). The Macintosh Classic logic board has 1 MB of soldered RAM. The optional memory expansion board also has 1 MB of soldered RAM. You may add RAM to the system by installing two Single In-line Memory Modules (SIMMs) on the memory expansion board. Adding two 256K SIMMs brings the system total to 2.5 MB; adding two 1 MB SIMMs brings the total to 4 MB.

IMPORTANT: *The two SIMM slots must contain two SIMMs of like memory capacity (two 256K SIMMs or two 1 MB SIMMs), or both slots must be empty.*

SIMM Identification

SIMMs for the Macintosh Classic are available in various sizes. Some can be used interchangeably.

IMPORTANT: *Refer to the  Quick Reference: SIMM Compatibility chart for SIMM compatibility. Follow this chart carefully! Some SIMMs that may appear to be interchangeable with others are not.*

You must use 120 ns (or faster) SIMMs in the Macintosh Classic. SIMMs with a slower rating will cause serious timing problems. The RAM speed is usually indicated by the -xx number after the manufacturer's part number. For example, -15 indicates 150 ns SIMMs and -10 indicates 100 ns SIMMs.

CAUTION: *SIMMs are very susceptible to damage from ESD and skin acid. When examining SIMMs, wear a grounding strap and handle the SIMMs only by the edges!*

Installing Upgrades

For detailed take-apart, CRT discharge, and SIMM installation instructions, see Section 2, Take-Apart.

□ SIMM UPGRADES – MACINTOSH CLASSIC II

RAM Configurations

The Macintosh Classic II can have 2 MB, 4 MB, 6 MB, or 10 MB of RAM. The Macintosh Classic II logic board has 2 MB of soldered RAM. You may add RAM to the system by installing SIMMs directly onto the logic board in the SIMM slots. Adding two 1 MB SIMMs brings the total system RAM to 4 MB; adding two 2 MB SIMMs brings the total system RAM to 6 MB; adding two 4 MB SIMMs brings the total system RAM to 10 MB.

IMPORTANT: *The two SIMM slots must contain two SIMMs of like memory capacity (two 1 MB SIMMs, two 2 MB SIMMs, or two 4 MB SIMMs), or both slots must be empty.*

SIMM Identification

SIMMs for the Macintosh Classic II are available in three sizes—1 MB, 2 MB, and 4 MB—and come in several vendor versions that you can use interchangeably. The Classic II uses the same SIMMs as the Macintosh LC. (Do not use Macintosh Classic SIMMs in the Macintosh Classic II unless they are 100 ns or faster.) For identification of the various versions, refer to the  *Quick Reference: SIMM Compatibility* card.

You must use 100 ns (or faster) SIMMs in the Macintosh Classic II. SIMMs with a slower rating will cause serious timing problems. The RAM speed is usually indicated by the -xx number after the manufacturer's part number. For example, -15 indicates 150 ns SIMMs and -12 indicates 120 ns SIMMs.

CAUTION: *SIMMs are very susceptible to damage from ESD and skin acid. When examining SIMMs, wear a grounding strap and handle the SIMMs only by the edges!*

Installing Upgrades

For detailed take-apart, CRT discharge, and SIMM installation instructions, see Section 2, Take-Apart.

□ BATTERY REPLACEMENT

Introduction

Lithium thionyl chloride batteries, the type used in the Macintosh Classic and Classic II, have a potential for explosion or overheating if improperly handled. Take the following precautions when storing, handling, or disposing of lithium batteries:

- Apple seals lithium batteries in individual zip-lock wrappers. Inspect the batteries for integrity of their wrappers. Store batteries in the same packaging, or in a similar closed, heavy plastic bag.
- Store lithium batteries in a designated, well-marked area with limited access.
- Lithium batteries **cannot** be recharged.

WARNING: A violent chemical reaction may occur if you attempt to recharge a lithium battery.

- Do not allow the leads or terminals to short-circuit.
- Replace the battery with the correct Apple replacement battery only.
- When installing the battery, verify correct polarity. The polarity markings on the battery must match those on the battery holder or circuit board.
- If the battery holder has a cover, replace the cover.
- If the dead battery has leads, remove them before disposing of the battery.
- Do not dispose of the battery in a fire or incinerator. The battery may explode.
- Lithium is water-reactive. Dispose of lithium compounds as hazardous waste, as follows:

Place the dead battery into the zip-lock wrapper and packaging from which you took the replacement battery. Mark the battery package *DEAD* and return it to Apple for proper disposal. Exception: If the battery is physically damaged (for example, leaking), do not return it to Apple; dispose of the battery locally according to your local ordinances.

Replacement Procedure

The Macintosh Classic and Classic II contain a single, long-life lithium battery in a plastic battery holder. If the battery fails, replace it by using the following procedure. Refer to **Figure 6-1** when replacing the battery.

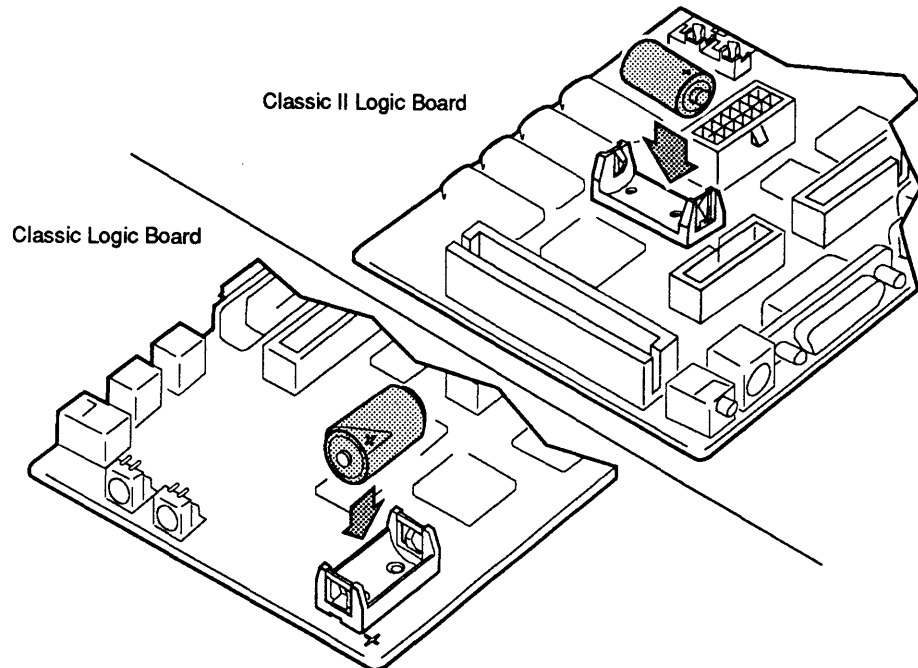

Figure 6-1 Battery Replacement

1. Remove the cover and discharge the CRT.
2. After you discharge the CRT, move the computer onto a grounded workbench pad and put on a grounding wriststrap.
3. Remove the main logic board and place it on the grounded workbench pad.
4. Grasp the old battery with your fingers and pull it from the battery holder.
5. Orient the new battery so that the end marked "+" matches the "+" on the main logic board. Insert the battery into the battery holder.
6. Replace the main logic board and the cover.
7. Package the old battery as directed in the introduction to this procedure. Return the battery to Apple for proper disposal.

□ MACINTOSH CLASSIC II UPGRADE

Introduction

Use a Macintosh Classic II upgrade kit to upgrade a Macintosh Classic to a Macintosh Classic II. The upgrade kit includes the following items:

- Classic II logic board
- Classic II rear housing
- Microphone
- Accessory kit

Upgrade Procedure

To upgrade a Macintosh Classic, remove the Classic logic board and replace it with the Classic II logic board in the upgrade kit. Install the Classic II rear housing, which provides an opening for the sound input port. Give the microphone and accessory kit to the customer.

Refer to Section 2, Take-Apart, for instructions on how to replace the main logic board and rear housing.

CAUTION: Take care that the connections to the sound-out and sound input ports are correct. Inserting the wrong equipment into the wrong port could damage the Macintosh Classic II or external equipment.

Macintosh Classic and Classic II

Illustrated Parts List

□ CONTENTS

- IPL.3 Internal View (Figure 1)
- IPL.5 Memory Expansion Board – Classic Only
(Figure 2)
- IPL.5 DRAM SIMMs – Classic II Only (Figure 3)
- IPL.7 Internal Drives (Figure 4)

Note: The figures and lists in this section include all piece parts that can be purchased separately from Apple for the Macintosh Classic or Classic II, along with their part numbers. These are the only parts available from Apple. Refer to your *Apple Service Programs* manual for prices.

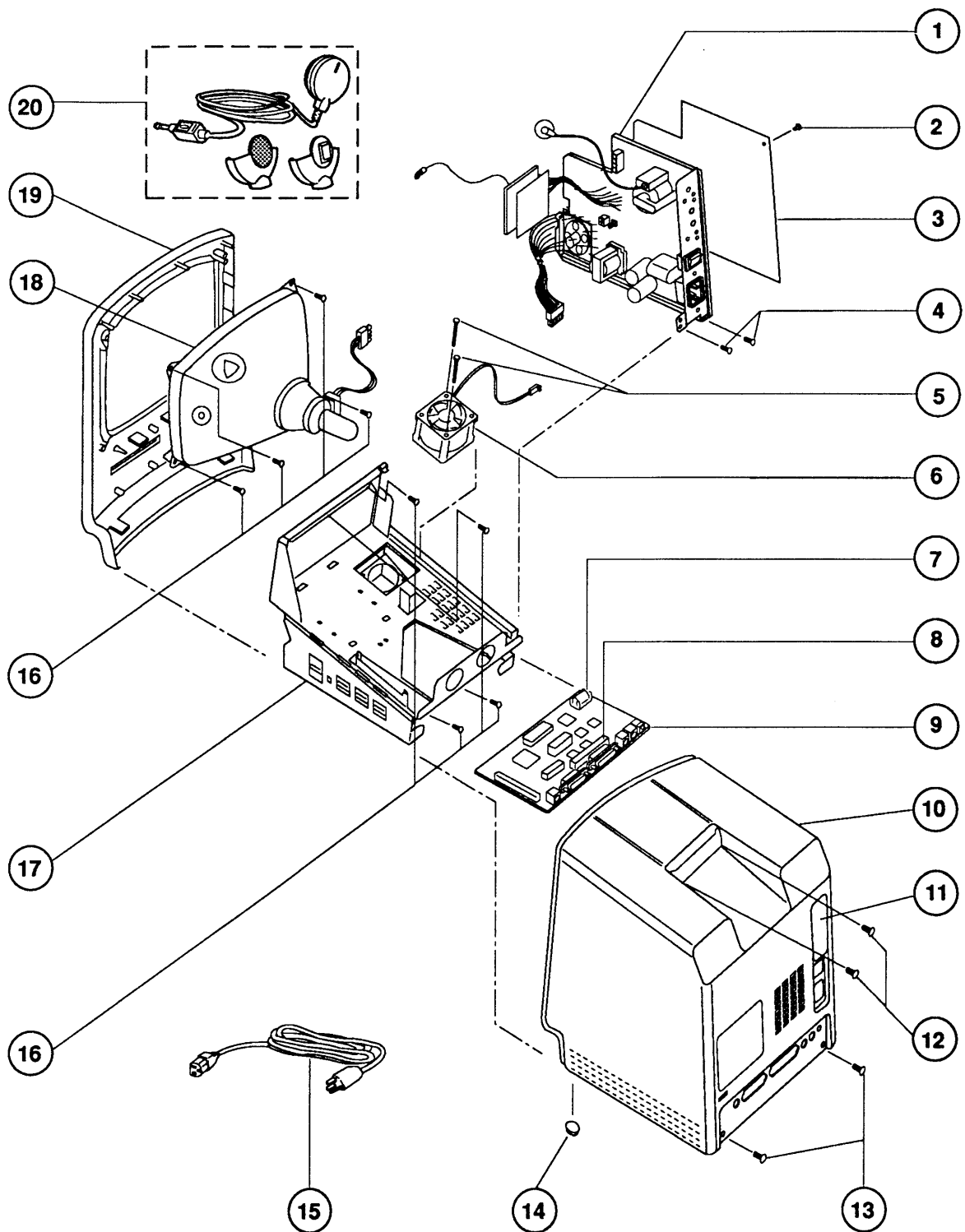

Figure 1 Internal View

INTERNAL VIEW (Figure 1)

Item	Part No.	Description
1	661-0597	Power/Sweep Board 110 V, Rev A (Macintosh Classic)
	661-0599	Power/Sweep Board 220 V, Rev A (Macintosh Classic)
	661-0651	Power/Sweep Board 110 V, Rev B (Macintosh Classic or Classic II)
	661-0652	Power/Sweep Board 220 V, Rev B (Macintosh Classic or Classic II)
2	830-0270	Rivet, Nylon Snap-In, Black
3	815-1216	Insulator, Power/Sweep Board
4	490-0001	Screw (power/sweep to chassis; HDA to Apple SuperDrive)
5	416-1330	Screw, metric, 3 x 0.5 x 30 mm (fan to plenum)
6	982-0055	Fan
7	742-0011	Lithium Battery (without leads)
8	630-0408	Internal SCSI Terminator (Macintosh Classic)
9	661-0596	Main Logic Board (Macintosh Classic)
	661-0672	Main Logic Board (Macintosh Classic II)
10	630-5812	Rear Housing Assembly with Feet, Rev A (Macintosh Classic)
	630-6045	Rear Housing Assembly with Feet (Macintosh Classic II)
11	815-1195	Rear Housing Access Door
12	426-1007	Screw, Tap, metric, 4.22 x 1.41 x 16 mm, Torx, Zinc (case top)
13	435-5002	Screw, Tap, 8.32 x 0.625 Fill, Torx, Zinc Oxide (case bottom)
14	865-0051	Platinum Foot
15	590-0380	Power Cable, AC, 110 V, Smoke
16	426-1001	Screw, Tap, metric, 4.22 x 1.41 x 13 mm, Torx, Zinc (CRT to bezel; chassis to bezel)
17	630-5818	Chassis with Plenum
18	076-0103	CRT and Yoke Assembly, Rev A (Macintosh Classic)
	630-5954	CRT and Yoke Assembly, Rev B (Macintosh Classic or Classic II)
19	630-5825	Front Bezel (Macintosh Classic)
	630-6046	Front Bezel ((Macintosh Classic II)
20	699-5103	Microphone (Macintosh Classic II)

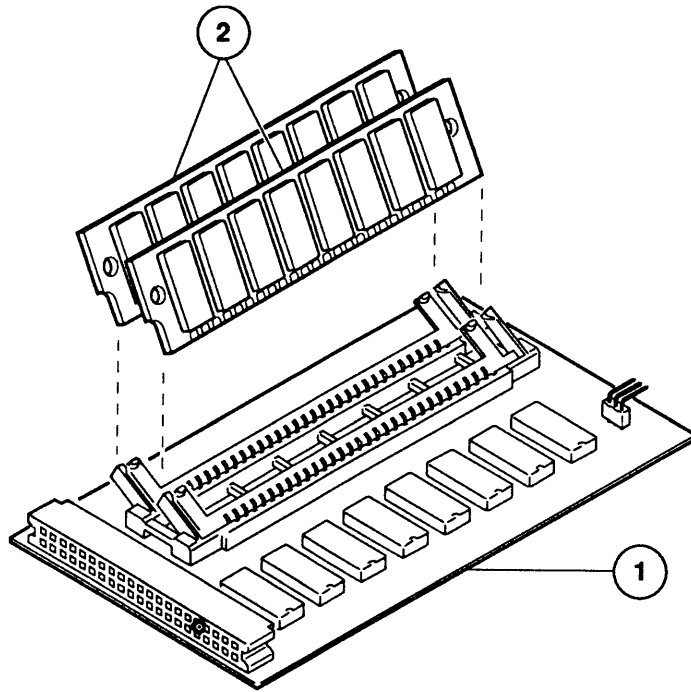

Figure 2 Memory Expansion Board—Macintosh Classic only

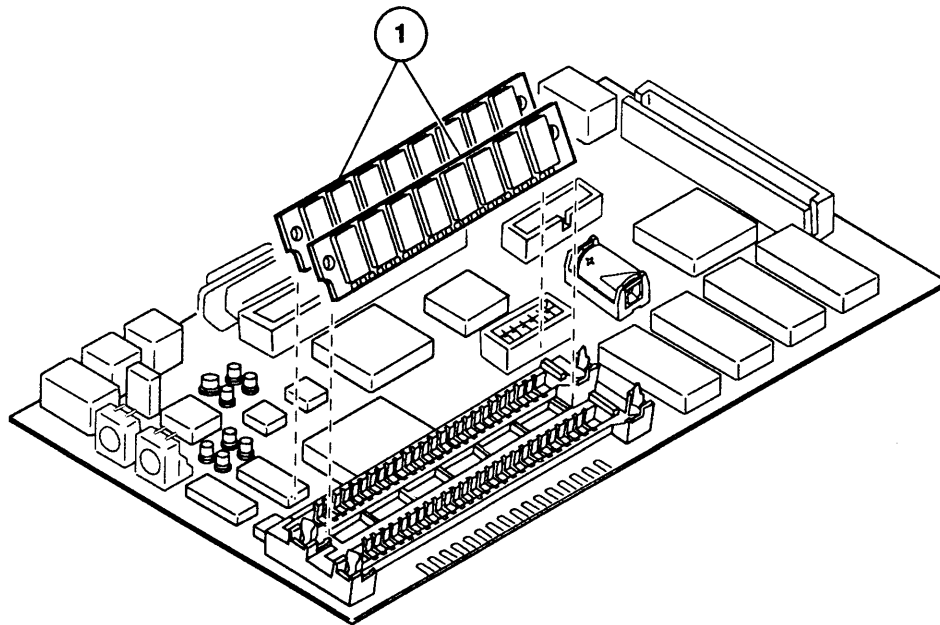



Figure 3 DRAM SIMMs—Macintosh Classic II only

□ MEMORY EXPANSION BOARD – CLASSIC ONLY (Figure 2)

<u>Item</u>	<u>Part No.</u>	<u>Description</u>
1	661-0598	Memory Expansion Board without SIMMs
2	661-0402	SIMM, 256K, 120 ns
	661-0403	SIMM, 1 MB, 120 ns
	661-0410	SIMM, DIP, 1 MB, 120 ns
	661-0494	SIMM, DIP, 256K, 120 ns
	661-0519	SIMM, 256K, 80 ns
	661-0520	SIMM, 1 MB, 80 ns

IMPORTANT: Refer to the  Quick Reference: SIMM Compatibility chart for a comprehensive list of all compatible SIMMs.

□ DRAM SIMMS – CLASSIC II ONLY (Figure 3)

<u>Item</u>	<u>Part No.</u>	<u>Description</u>
1	661-0520	SIMM, 1 MB, 80 ns
	661-0719	SIMM, 1 MB, 80 ns
	661-0643	SIMM, 2 MB, 80 ns

IMPORTANT: Refer to the  Quick Reference: SIMM Compatibility chart for a comprehensive list of all compatible SIMMs.

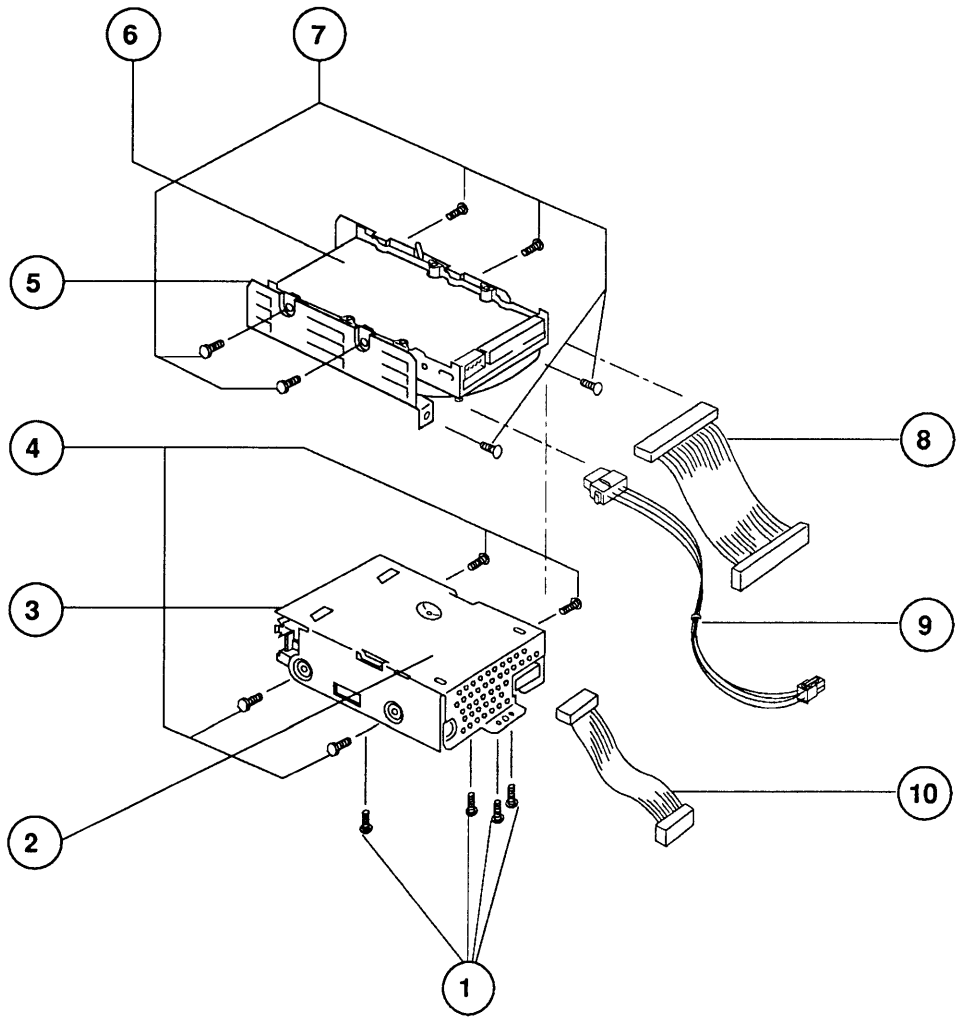

Figure 4 Internal Drives

□ INTERNAL DRIVES (Figure 4)

<u>Item</u>	<u>Part No.</u>	<u>Description</u>
-	602-0164	Service Packaging, HDA, 3.5-Inch, Half-Height (replaced by 602-0282 or 602-0308)
-	602-0210	Service Packaging, 800K/1.4 MB Drive
-	602-0308	Service Packaging, HDA, 3.5-Inch, 1-Inch-Height, Without Carrier (also for 19 mm floppy drive)
1	462-4100	Screw, Apple SuperDrive (SuperDrive carrier to chassis)
2	805-5050	Drive Carrier, 800K and SuperDrive
3	661-0474	1.4 MB Mechanism, Disk Drive
4	460-3400	Screw, Metric, 3 x 0.5 x 6 mm (SuperDrive carrier to SuperDrive)
5	805-0950	Carrier, HDA, Internal, 3.5, SCSI
6	661-0614	HDA, 1" Internal, 40 MB, 3.5, SCSI (Macintosh Classic or Classic II)
	661-0624	HDA, 1" Internal, 80 MB, 3.5, SCSI (Macintosh Classic II)
7	444-6104	Screw, 6 - 32 x 0.250 (HDA carrier to HDA)
8	590-0211	Cable, HDA, Internal (SCSI connector cable)
9	590-0521	Cable, HDA, Power
10	590-0167	Cable, Internal Floppy Drive, 1.4 MB Apple SuperDrive, (red stripe)

