

digital

PDP 11/45 MAINTENANCE
REFERENCE MANUAL

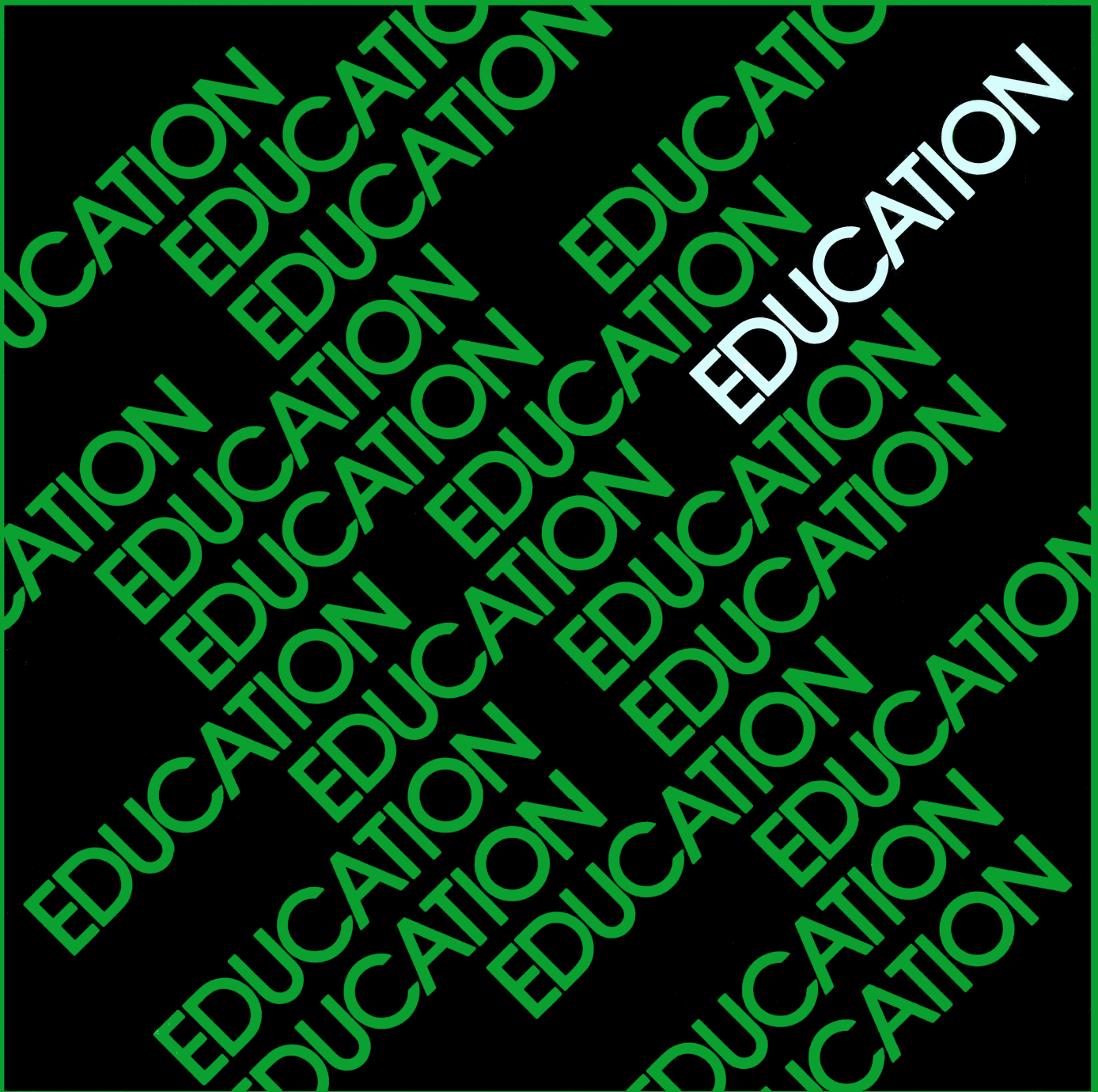

PDP 11/45 MAINTENANCE

REFERENCE MANUAL

1st Edition, November 1972
2nd Printing, October 1973

Copyright ©1972, 1973 by Digital Equipment Corporation

The material in this manual is for informational purposes and is subject to change without notice.

The following are trademarks of Digital Equipment Corporation, Maynard, Massachusetts:

DEC	PDP
FLIP CHIP	FOCAL
DIGITAL	COMPUTER LAB

CONTENTS

	Pages
CP INSTRUCTION SET	1–12
MEMORY MANAGEMENT	13–15
SEMICONDUCTOR MEMORY	16–23
CORE MEMORY	24–25
FLOATING POINT PROCESSOR	26–48
OP CODE DETERMINATION	49
MEMORY MAP AND PROGRAM LOADERS	50–53
ADDRESS MODES	54–56
CONSOLE	57
KB11-A BLOCK DIAGRAM	58–59
MODULE LOCATIONS	60
DEVICE REGISTER ADDRESSES	61
ASCII CODE	62

INSTRUCTION CARD LEGEND

	OP Fields	Time
n	Byte(1)/Word(0)	Add 150 ns if Destination is an odd byte, except where dst = R7 or where dst mode equals 0 and src, where applicable, is 0.
src	Source Field – 6 Bits	
dst	Destination Field – 6 Bits	Add 90 ns/memory reference if memory management KT11 is in operation.
R	Register – 3 Bits	
FS	Floating Source – 6 Bits	
FD	Floating Destination – 6 Bits	
AC	Floating Accumulator – 2 Bits	
XXX	Offset – 8 Bits	
YY	Offset – 6 Bits	
NN	Count – 6 Bits	
N	Count – 3 Bits	
^	AND	
∨	Inclusive OR	
⊖	Exclusive OR	
()	Contents of	Condition Codes
loc	Location	
←	Becomes	* Conditionally Set
↑	Is Popped from Stack	- Not affected
↓	Is Pushed onto Stack	0 Cleared
~	Boolean Not	1 Set

GENERAL ADDRESSING MODES

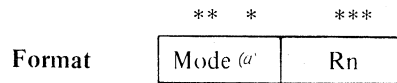

- *Direct/deferred bit for source and destination address
- **Specifies how selected registers are to be used
- ***Specifies a general register

Mode	Name	Symbol	Function
0	Register	%R	Register contains operand.
1	Register Deferred	(<i>a</i> '%R or (R)	Register contains the address of the operand.
2	Auto-increment	(R)+	Register contains the address of the operand. Register contents incremented after reference.
3	Auto-increment Deferred	(<i>a</i> '(R)+	Register is first used as a pointer to a word containing the address of the operand, then incremented (always by 2, even for byte instructions).
4	Auto-decrement	-(R)	Register contents decremented before reference. Register contains the address of the operand.
5	Auto-decrement Deferred	(<i>a</i> '-(R)	Register is decremented (always by 2, even for byte instructions), then used as a pointer to a word containing the address of the operand.
6	Index	±X(R)	Value X (stored in a word following the instruction) is added to (R) to produce the address of the operand. Neither X nor (R) is modified.
7	Index Deferred	(<i>a</i> '±X(R) or <i>a</i> '(R)	Value X (stored in a word following the instruction) and (R) are added and the sum is used as a pointer to a word containing the address of the operand. Neither X nor (R) is modified.
(±X is an Index value)			

SPECIAL (PC) ADDRESSING MODES

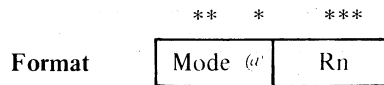

- *Direct/deferred bit for source and destination address
- **Specifies how selected register is to be used
- ***Specifies register 7 (PC)

Mode	Name	Symbol	Function
2	Immediate	#n	Operand follows instruction.
3	Absolute	@#A	A follows instruction is the address of the operand. (A = absolute address.)
6	Relative	A	A is the address of the operand. (A = Index value following the instruction plus updated PC.)
7	Relative Deferred	@A	A is the address of a word containing the address of the operand. (A = Index value following the instruction plus updated PC.)

BRANCH ADDRESSING

$$\text{OFFSET} = \frac{(\text{effective address}) - (\text{updated PC})}{2}$$

$$\text{EFFECTIVE ADDRESS} = (\text{offset} \times \text{two}) + (\text{updated PC})$$

Branching from location 500		
PC	OFFSET	
470	373	
472	374	
474	375	
476	376	
500	377	
502	000	
504	001	
506	002	
510	003	
	Instruction	

OFFSET – Number of words to branch from updated PC.

EFFECTIVE ADDRESS – The location to branch too.

UPDATED PC – Location of instruction plus two.

CONDITION CODES OPERATORS: OPR

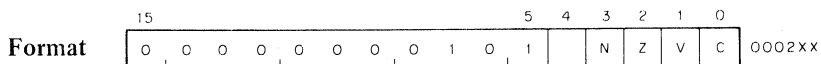

11 1463

Condition code operator set or clear condition code bits. Indicated bits of the instruction word (3-0) if = to a ONE, affect the indicated condition code bits NZVC according to bit 4.

Bit 4 = 0 Clear condition code bits
 Bit 4 = 1 Set condition code bits

Mnemonic	Instruction/Operation	OP Code	Condition Code NZVC	Time
—	No Operation	000240	----	600 ns
CLC	CLear C C ← 0	000241	---0	600 ns
CLV	CLear V V ← 0	000242	--0-	600 ns
CLZ	CLear Z Z ← 0	000244	-0--	600 ns
CLN	CLear N N ← 0	000250	0---	600 ns
CCC	Clear all CC's N, Z, V, C ← 0	000257	0000	600 ns
—	No Operation	000260	----	600 ns
SEC	SEt C C ← 1	000261	---1	600 ns
SEV	SEt V V ← 1	000262	--1-	600 ns
SEZ	SEt Z Z ← 1	000264	-1--	600 ns
SEN	SEt N N ← 1	000270	1---	600 ns
SCC	Set all CC's N, Z, V, C ← 1	000277	1111	600 ns
Combinations of the above Clear instructions can be ORed together to form combined Clear instructions.				
—	Clear V and C V, C ← 0	000243	--00	600 ns
Combinations of the above Set instructions can be ORed together to form combined Set instructions.				
—	Set N and V N, V ← 1	000272	1-1-	600 ns

CONDITIONAL BRANCHES: OPR loc

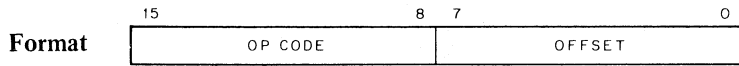

11-1462

The instruction causes a branch to a location defined by the sum of the offset (multiplied by 2) and the current contents of the program counter, if conditions are met.

TIME: Branch 600 ns/No Branch 300 ns

Mnemonic	Instruction/Operation	OP Code
BR	BRanch (unconditionally) PC ← loc	0004+XXX
BNE	Branch if Not Equal (zero) PC ← loc if Z=0	0010+XXX
BEQ	Branch if EQual (zero) PC ← loc if Z=1	0014+XXX
BGE	Branch if Greater or Equal (zero) PC ← loc if N=V	0020+XXX
BLT	Branch if Less Than (zero) PC ← loc if N≠V	0024+XXX
BGT	Branch if Greater Than (zero) PC ← loc if Z=0 and N=V	0030+XXX
BLE	Branch if Less than or Equal (zero) PC ← loc if Z=1 or N≠V	0034+XXX
BPL	Branch if PPlus PC ← loc if N=0	1000+XXX
BMI	Branch if MInus PC ← loc if N=1	1004+XXX
BHI	Branch if HIGher PC ← loc if C=0 and Z=0	1010+XXX
BLOS	Branch if LOver or Same PC ← loc if C=1 or Z=1	1014+XXX
BVC	Branch if oVerflow Clear PC ← loc if V=0	1020+XXX
BVS	Branch if oVerflow Set PC ← loc if V=1	1024+XXX
BCC	Branch if Carry Clear PC ← loc if C=0	1030+XXX
BHIS	Branch if HIGher or Same PC ← loc if C=0	1030+XXX
BCS	Branch if Carry Set PC ← loc if C=1	1034+XXX
BLO	Branch if LOver PC ← loc if C=1	1034+XXX

SINGLE OPERAND INSTRUCTIONS: OPR dst

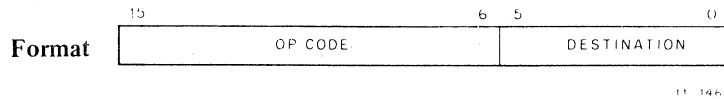

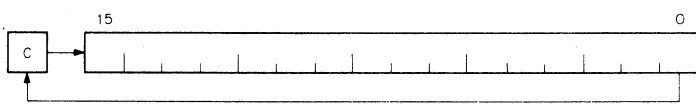
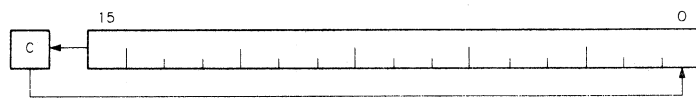
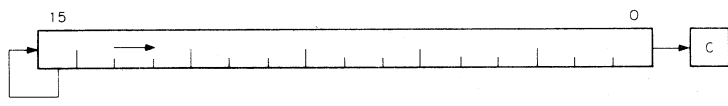
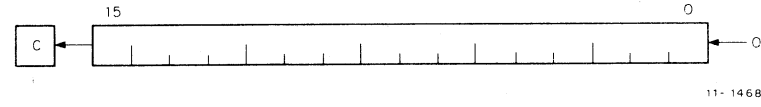
Mnemonic	Instruction/Operation	OP Code	Condition Code NZVC	Time
CLR(B)	CLear (Byte) (dst) ← 0	n050DD	0100	300 ns
COM(B)	COMplement (Byte) (dst) ← ~(dst)	n051DD	**01	300 ns
INC(B)	INCrement (Byte) (dst) ← (dst) + 1	n052DD	***_	300 ns
DEC(B)	DECrement (Byte) (dst) ← (dst) - 1	n053DD	***_	300 ns
NEG(B)	NEGate (Byte) (dst) ← ~(dst) + 1	n054DD	****	300 ns
ADC(B)	ADD Carry (Byte) (dst) ← (dst) + (c)	n055DD	****	300 ns
SBC(B)	SUBtract Carry (Byte) (dst) ← (dst) - (c)	n056DD	****	300 ns
TST(B)	TeST (Byte) (dst) ← (dst)	n057DD	**00	300 ns
ROR(B)	ROtate Right (Byte) (dst) ← (dst) 1 place right with (c)	n060DD	****	300 ns
				
ROL(B)	ROtate Left (Byte) (dst) ← (dst) 1 place left with (c)	n061DD	****	300 ns
				
ASR(B)	Arithmetic Shift Right (Byte) (dst) ← (dst) shifted 1 place right	n062DD	****	300 ns
				
ASL(B)	Arithmetic Shift Left (Byte) (dst) ← (dst) shifted 1 place left	n063DD	****	300 ns
				
SXT	Sign eXTend (dst) ← 0 if N=0 (dst) ← -1 if N=1	0067DD	-*0-	300 ns
SWAB	SWAp Bytes (dst byte 0) ← (dst byte 1) (dst byte 1) ← (dst byte 0)	0003DD	**00	300 ns

DOUBLE OPERAND INSTRUCTIONS: OPR src, dst

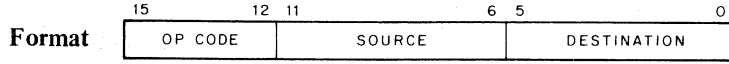

11-1469

Mnemonic	Instruction/Operation	OP Code	Condition Code NZVC	Time
MOV(B)	MOVe (Byte) (dst) ← (src)	n1SSDD	**0 -	300 ns
CMP(B)	CoMPare (Byte) (src) + ~ (dst) + 1 (src), (dst) unaffected	n2SSDD	****	300 ns
BIT(B)	BlT Test (Byte) (dst) ∧ (src) (dst), (src) unaffected	n3SSDD	**0 -	300 ns
BIC(B)	BlT Clear (Byte) (dst) ← ~ (src) ∧ (dst)	n4SSDD	**0 -	300 ns
BIS(B)	BlT Set (Byte) (dst) ← (src) ∧ (dst)	n5SSDD	**0 -	300 ns
ADD	ADD (dst) ← (src) + (dst)	06SSDD	****	300 ns
SUB	SUBtract (dst) ← (dst) + ~ (src) + 1	16SSDD	****	300 ns

REGISTER SRC/DST INSTRUCTIONS: OPR src, R

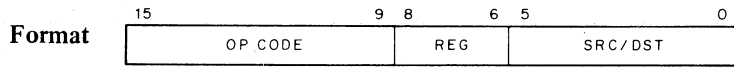

11-1470

Mnemonic	Instruction/Operation	OP Code	Condition Code NZVC	Time
MUL	MULtiply R, RV1 ← (R) x (src)	070RSS	**0*	3.3 μs
DIV	DIVide quotient R ← $\frac{(R), (RV1)}{(src)}$ remainder RV1	071RSS	****	6.9-7.5 μs
ASH	ArithmetiC SHift R ← (R) Arith shifted N places right or left	072RSS	****	750 ns+
ASHC	ArithmetiC SHift Combined R, RV1 ← (R), (RV1) Arith shifted (two words) N places right or left	073RSS	****	750 ns+

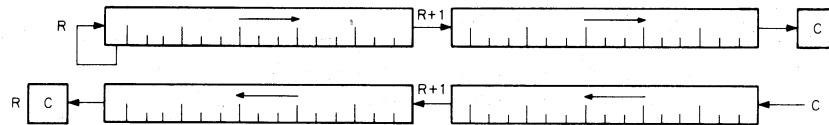

11-1471

XOR	Exclusive OR (dst) ← R ∨ (dst) Note: Syntax format is XOR R, dst	074RDD	**0 -	300 ns
-----	--	--------	-------	--------

SUBROUTINE INSTRUCTIONS

Mnemonic	Instruction/Operation	OP Code	Condition Code NZVC	Time
JSR	Jump to SubRoutine $tmp \leftarrow (dst)$ $\downarrow(SP) \leftarrow (reg)$ $reg \leftarrow (PC)$ $PC \leftarrow (tmp)$	004RDD	----	1.5 μs
Format	<div style="display: flex; align-items: center; gap: 10px;"> <div style="border: 1px solid black; padding: 2px;"> <div style="display: flex; justify-content: space-between; width: 100%;"> 15 9 8 6 5 0 </div> <div style="display: flex; justify-content: space-between; width: 100%;"> OP CODE REG DESTINATION </div> </div> OPR R, DST </div>			
RTS	ReTurn from Subroutine $PC \leftarrow (reg)$ $reg \leftarrow (SP)\uparrow$	00020R	----	1.2 μs
Format	<div style="display: flex; align-items: center; gap: 10px;"> <div style="border: 1px solid black; padding: 2px;"> <div style="display: flex; justify-content: space-between; width: 100%;"> 15 3 2 0 </div> <div style="display: flex; justify-content: space-between; width: 100%;"> OP CODE REG </div> </div> OPR R </div>			
MARK	MARK $SP \leftarrow (PC) + (2xN)$ $PC \leftarrow (R5)$ $R5 \leftarrow (SP)\uparrow$	0064NN	----	900 ns
Format	<div style="display: flex; align-items: center; gap: 10px;"> <div style="border: 1px solid black; padding: 2px;"> <div style="display: flex; justify-content: space-between; width: 100%;"> 15 6 5 0 </div> <div style="display: flex; justify-content: space-between; width: 100%;"> OP CODE NN </div> </div> OPR NN </div>			

PROGRAM CONTROL INSTRUCTIONS

Mnemonic	Instruction/Operation	OP Code	Condition Code NZVC	Time
SPL	Set Priority Level $PSW(7-5) \leftarrow N$	00023N	----	600 ns
Format	<div style="display: flex; align-items: center; gap: 10px;"> <div style="border: 1px solid black; padding: 2px;"> <div style="display: flex; justify-content: space-between; width: 100%;"> 15 3 2 0 </div> <div style="display: flex; justify-content: space-between; width: 100%;"> OP CODE N </div> </div> OPR N </div>			
JMP	JuMP $PC \leftarrow dst$	0001DD	----	600 ns
Format	<div style="display: flex; align-items: center; gap: 10px;"> <div style="border: 1px solid black; padding: 2px;"> <div style="display: flex; justify-content: space-between; width: 100%;"> 15 6 5 0 </div> <div style="display: flex; justify-content: space-between; width: 100%;"> OP CODE DESTINATION </div> </div> OPR DST </div>			
SOB	Subtract One and Branch $R \leftarrow (R) - 1$ $PC \leftarrow (PC) - (2xOFFSET)$ if result $\neq 0$ $PC \leftarrow (PC)$ if result = 0	077RYY	----	750 ns
Format	<div style="display: flex; align-items: center; gap: 10px;"> <div style="border: 1px solid black; padding: 2px;"> <div style="display: flex; justify-content: space-between; width: 100%;"> 15 9 8 6 5 0 </div> <div style="display: flex; justify-content: space-between; width: 100%;"> OP CODE REG OFFSET </div> </div> OPR R, A </div>			

OPERATE INSTRUCTIONS: OPR

Mnemonic	Instruction/Operation	OP Code	Condition Code NZVC	Time
HLT	HaLT CP ← Halt	000000	----	750 ns
WAIT	WAIT wait for interrupt	000001	----	
RTI	ReTurn from Interrupt PC ← (SP)↑ PSW ← (SP)↑	000002	****	1.5 μs
BPT	BreakPoint Trap ↓(SP) ← (PSW) ↓(SP) ← (PC) PC ← (loc 14) PSW ← (loc 16)	000003	****	2.25 μs
IOT	I/O Trap ↓(SP) ← (PSW) ↓(SP) ← (PC) PC ← (loc 20) PSW ← (loc 22)	000004	****	2.25 μs
RESET	RESET BUS INIT ← TRUE for 10 ms	000005	----	10 ms
RTT	ReTurn from Trap PC ← (SP)↑ PSW ← (SP)↑	000006	****	1.5 μs
EMT	EMulator Trap ↓(SP) ← (PSW) ↓(SP) ← (PC) PC ← (loc 30) PSW ← (loc 32)	104000 - 104377	****	2.25 μs
TRAP	TRAP ↓(SP) ← (PSW) ↓(SP) ← (PC) PC ← (loc 34) PSW ← (loc 36)	104400 - 104777	****	2.25 μs

- Notes:
1. HALT issued in SUPERVISOR or USER mode will generate a trap to vector 4.
 2. SPL or RESET issued in SUPERVISOR or USER mode will be a NO OP.
 3. BPT, IOT, EMT and TRAP push old PC and old PSW onto stack of mode you are going to.

PROCESSOR REGISTER ADDRESSES

GENERAL REGISTERS

R0	(000000)	R10	(000010)
R1	(000001)	R11	(000011)
R2	(000002)	R12	(000012)
R3	(000003)	R13	(000013)
R4	(000004)	R14	(000014)
R5	(000005)	R15	(000015)
R6 KERNEL SP	(000006)	R16 SUPER SP	(000016)
R7 PC	(000007)	R17 USER SP	(000017)

(addressable only by console)

DISPLAY REGISTER

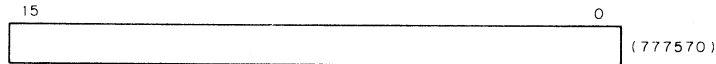

SWITCH REGISTER

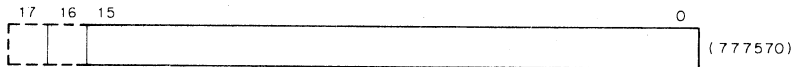

PROGRAM BREAK REGISTER (PB)

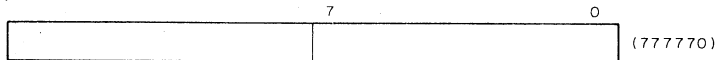

PROGRAM INTERRUPT REQUEST REGISTER (PIRQ)

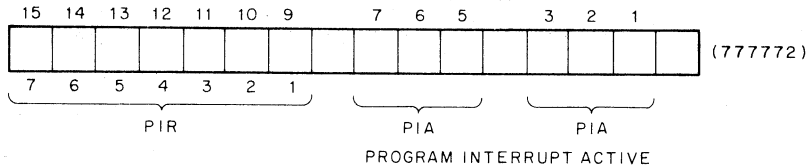

STACK LIMIT REGISTER (SL)

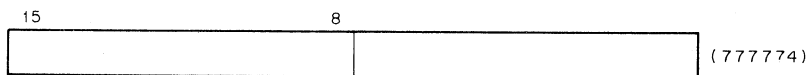

PROCESSOR STATUS WORD (PSW)

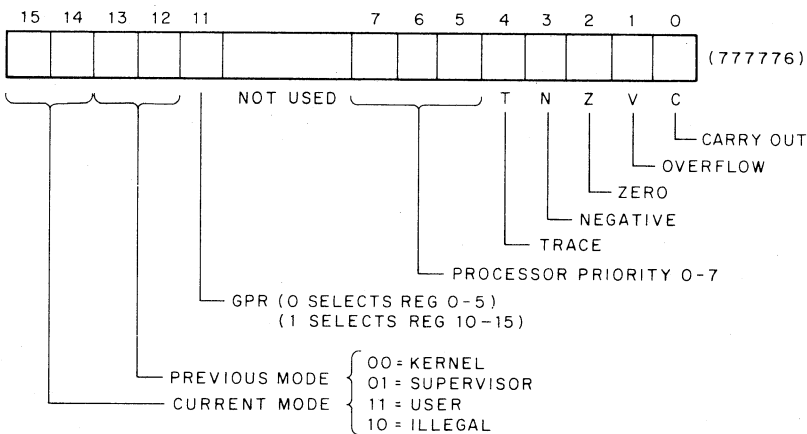

MEMORY PARITY CONTROL REGISTER

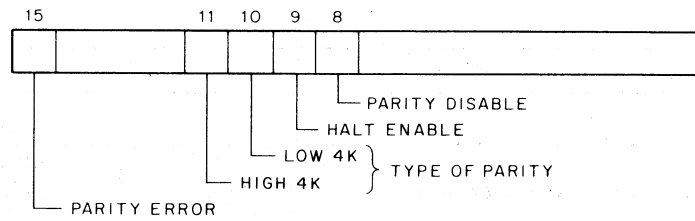

11-1484

Addressing

0 – 8K	772100
8K – 16K	772102
16K – 24K	772104
24K – 32K	772106
32K – 40K	772110
40K – 48K	772112
48K – 56K	772114
56K – 64K	772116
64K – 72K	772120
72K – 80K	772122
80K – 88K	772124
88K – 96K	772126
96K – 104K	772130
104K – 112K	772132
112K – 120K	772134
120K – 128K	772136

Bits 11 and 10 are associated with the high-order 4K and low-order 4K of this memory address bank. When set to a 1, they specify odd parity for their respective half banks; when clear, even parity.

When bit 9 is set, the machine will execute a halt if a parity error occurs; when clear, the machine will perform an effective timeout and interrupt through location 4.

When bit 8 is clear, a parity error will cause an interrupt (or halt as specified in bit 9); if it is set, no action will be taken on a parity error.

When the machine is powered up, the status registers have bit 15 cleared to 0, and the remaining bits set to 1: halt, odd parity enable, parity disable, and no error.

INTER-MODE COMMUNICATIONS: OPR dst or OPR src

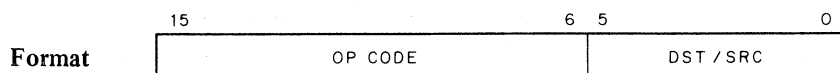

11-1485

Mnemonic	Instruction/Operation	OP Code	Condition Code NZVC	Time
MFPI	Move From Previous Instruction space (temp) ← (src) ↓(SP) ← (temp)	0065SS	**0 -	1.2 μs
MFPD	Move From Previous Data space (temp) ← (src) ↓(SP) ← (temp)	1065SS	**0 -	1.2 μs
MTPI	Move To Previous Instruction space (temp) ← (SP)↑ (dst) ← (temp)	0066DD	**0 -	900 ns
MTPD	Move To Previous Data space (temp) ← (SP)↑ (dst) ← (temp)	1066DD	**0 -	900 ns

KT11-C MEMORY MANAGEMENT STATUS REGISTER

Status Register 0 (SR0)

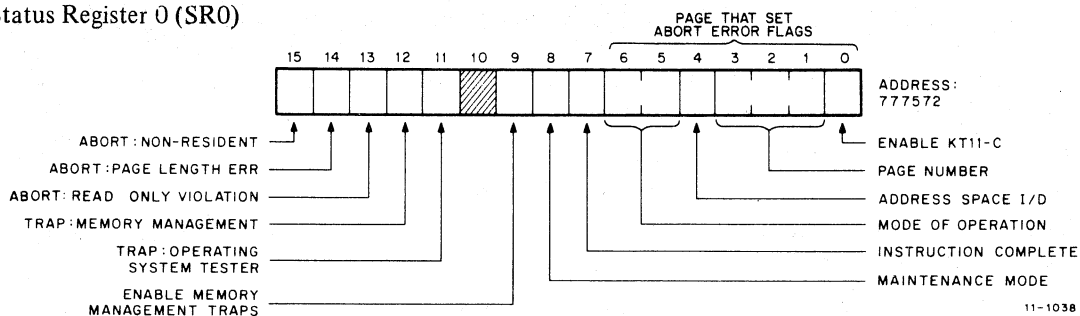

Status Register 1 (SR1)

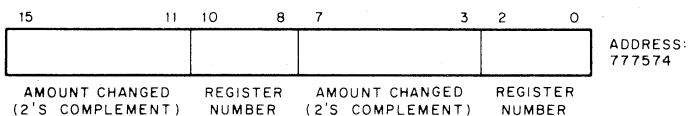

Status Register 2 (SR2)

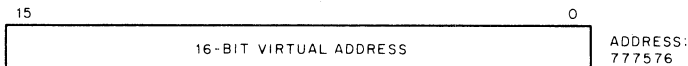

Status Register 3 (SR3)

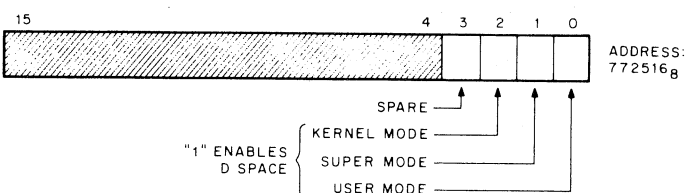

ACTIVE PAGE REGISTERS

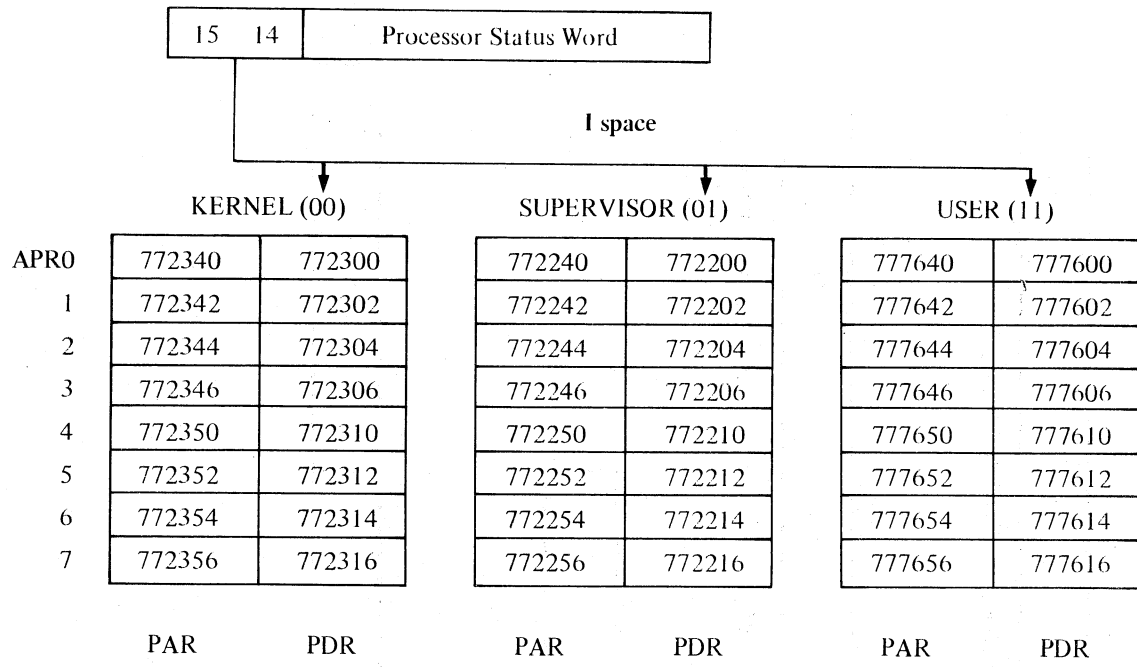

D space

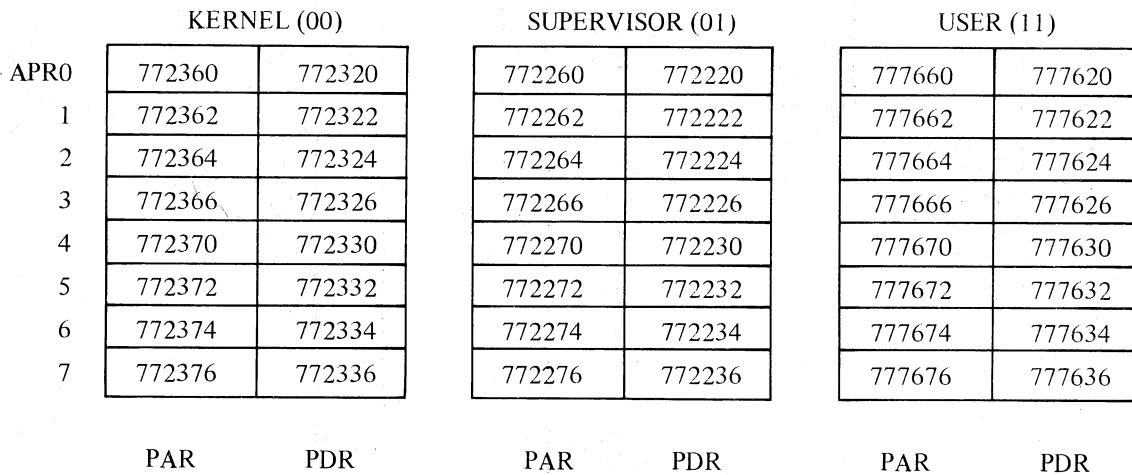

PAGE ADDRESS REGISTER

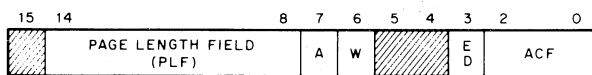

11-1037

PAGE DESCRIPTER REGISTER

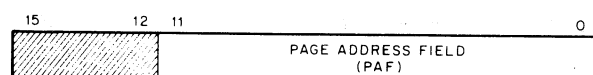

11-1036

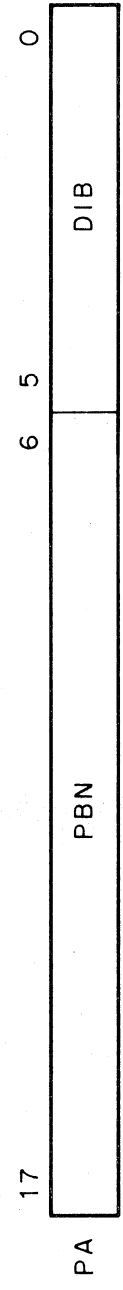
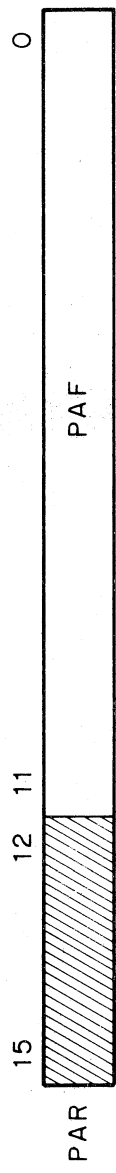
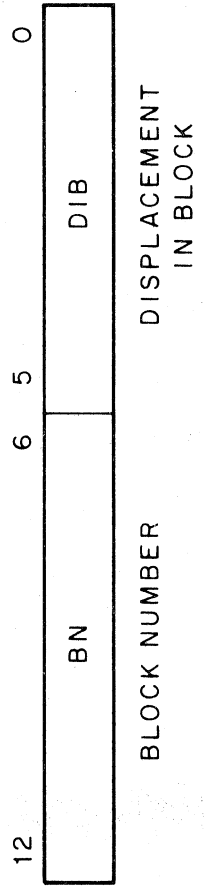
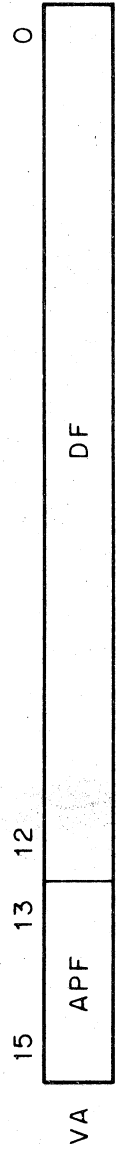

VIRTUAL TO PHYSICAL ADDRESS

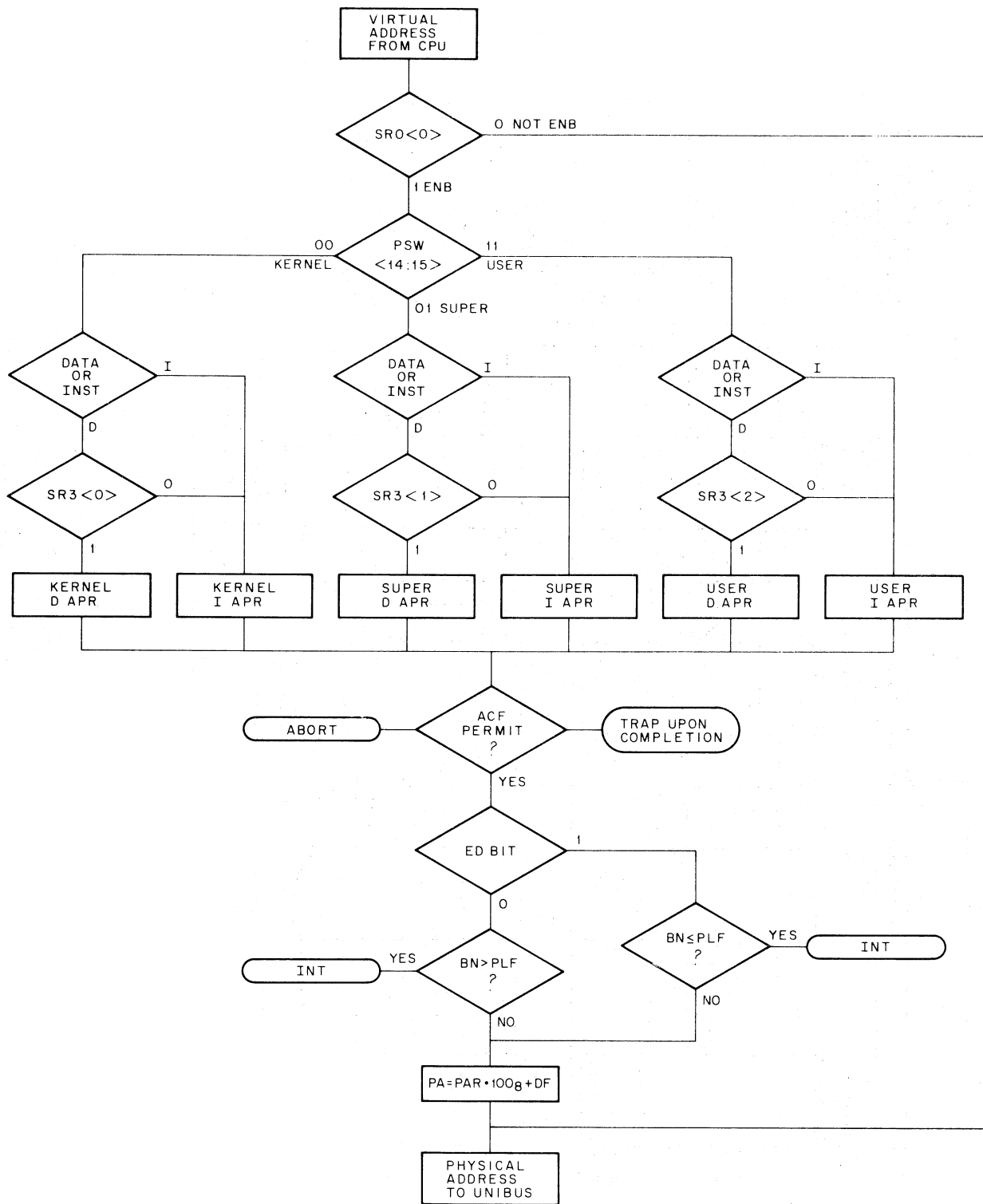

11-1487

Memory Management

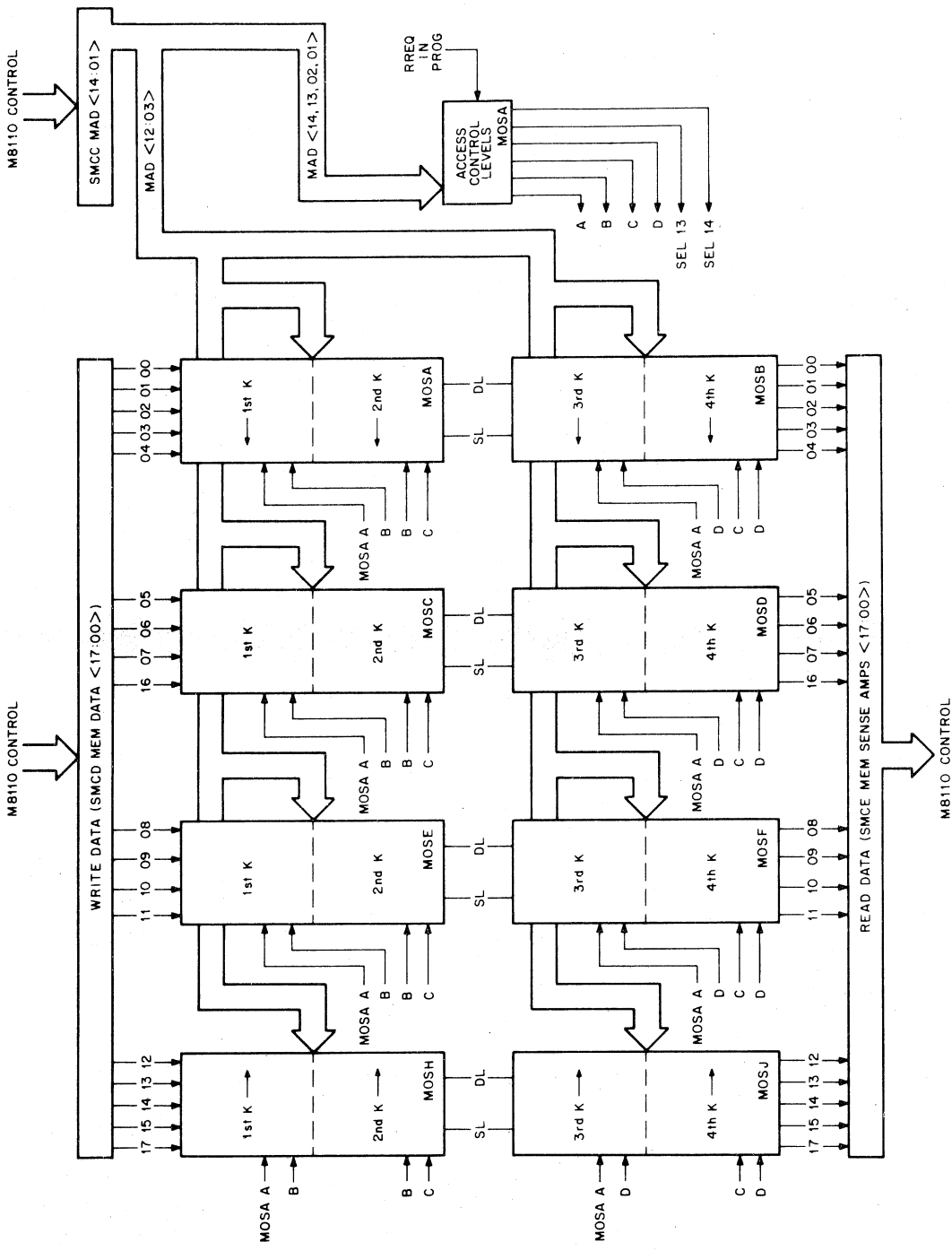

11-1324

MOS Memory Matrix Block Diagram

MOS Memory System Configuration

Memory Capacity Option		Option Type Number			
		MS11-BC	MS11-BD	MS11-BM	MS11-BP
		Module Complement			
With Parity	Without Parity	(1)M8110 (1)H746A (1)H744A	(1)M8110	(1)G401	(1) G401YA
4K		1			1
	4K	1		1	
8K		1			2
	8K	1		2	
12K		1			3
	12K	1		3	
16K		1			4
	16K	1		4	
20K		1	1		5
	20K	1	1	5	
24K		1	1		6
	24K	1	1	6	
28K		1	1		7
	28K	1	1	7	
32K		1	1		8
	32K	1	1	8	

MOS Matrix Selected Address Configuration (4 of 16K)

MAD		REQUIRED JUMPERS		MOS Matrix Memory Address Assignment
14	13	(MAD 14)	(MAD 13)	
0	0	C	A	0-4095
0	1	C	B	4096-8191
1	0	D	A	8192-12,287
1	1	D	B	12,288-16,383

MOS Matrix Control Level Generation and Selected Memory Address Block (1 of 4K)

MAD		CONTROL LEVELS GENERATED		Memory Address Block Selected
02	01	(MAD 02)	(MAD 01)	
0	0	MOSA B ●	MOSA A	0-1023
0	1	MOSA B ●	MOSA C	1024-2047
1	0	MOSA D ●	MOSA A	2048-3071
1	1	MOSA D ●	MOSA C	3072-4095

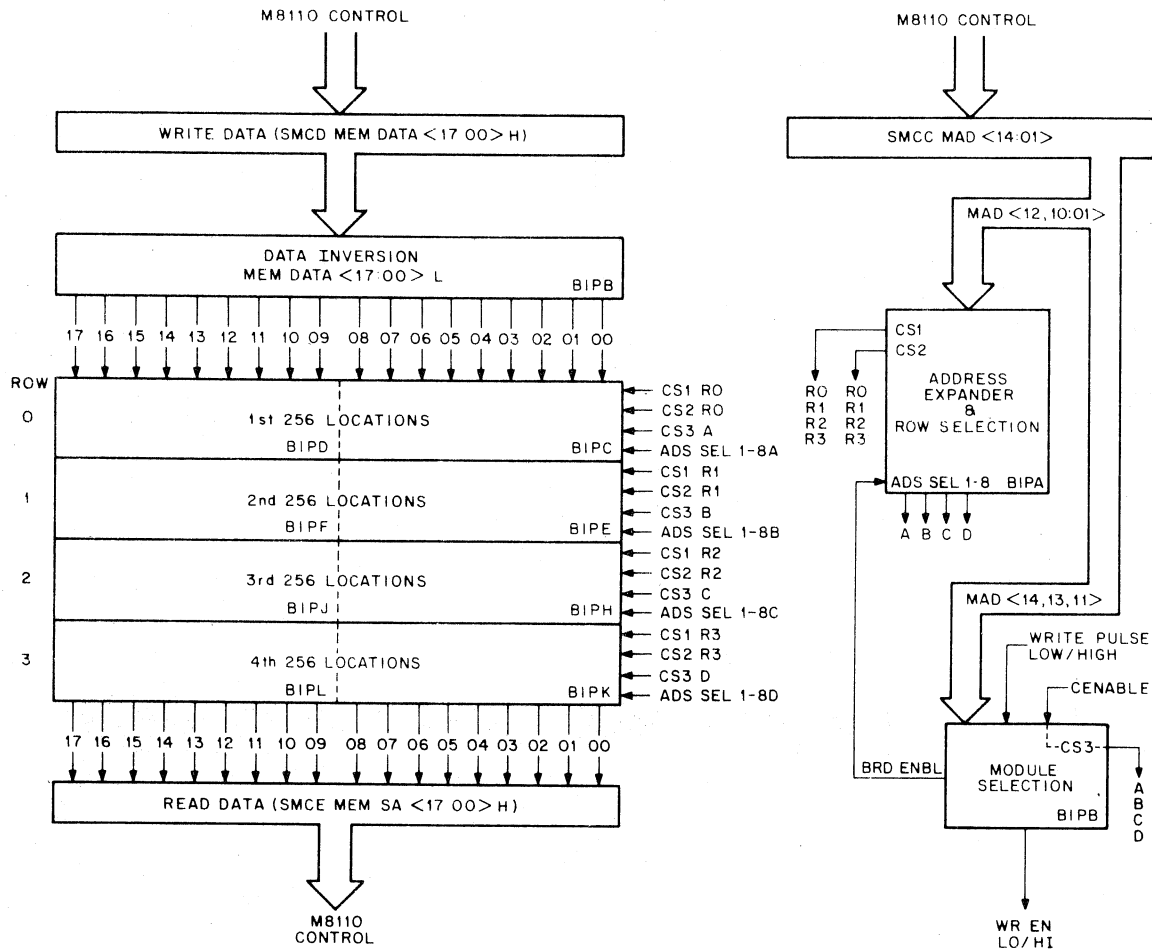

11-1325

Bipolar Memory Matrix

Bipolar Memory System Configuration

Memory Capacity Option		Option Type Number		
		MS11-CC	MS11-CM	MS11-CP
		Module Complement		
With Parity	Without Parity	(1)M8110 (2)H744A	(1)M8111	(1)M8111YA
1K		1		1
	1K	1	1	
2K		1		2
	2K	1	2	
3K		1		3
	3K	1	3	
4K		1		4
	4K	1	4	
5K		2		5
	5K	2	5	
6K		2		6
	6K	2	6	
7K		2		7
	7K	2	7	
8K		2		8
	8K	2	8	

Bipolar Matrix Selected Address Configuration (1 of 16K)

MAD				Required Jumpers				Memory Address Assignment
14	13	11	10	(MAD 14)	(MAD 13)	(MAD 11)	(MAD 10)	
0	0	0	0	D	F	H	B	0 to 1023
0	0	0	1	D	F	H	A	1024 to 2047
0	0	1	0	D	F	J	B	2048 to 3071
0	0	1	1	D	F	J	A	3072 to 4095
0	1	0	0	D	E	H	B	4096 to 5119
0	1	0	1	D	E	H	A	5120 to 6143
0	1	1	0	D	E	J	B	6144 to 7167
0	1	1	1	D	E	J	A	7168 to 8191
1	0	0	0	C	F	H	B	8192 to 9215
1	0	0	1	C	F	H	A	9216 to 10,239
1	0	1	0	C	F	J	B	10,240 to 11,263
1	0	1	1	C	F	J	A	11,264 to 12,287
1	1	0	0	C	E	H	B	12,288 to 13,311
1	1	0	1	C	E	H	A	13,312 to 14,335
1	1	1	0	C	E	J	B	14,336 to 15,359
1	1	1	1	C	E	J	A	15,360 to 16,383

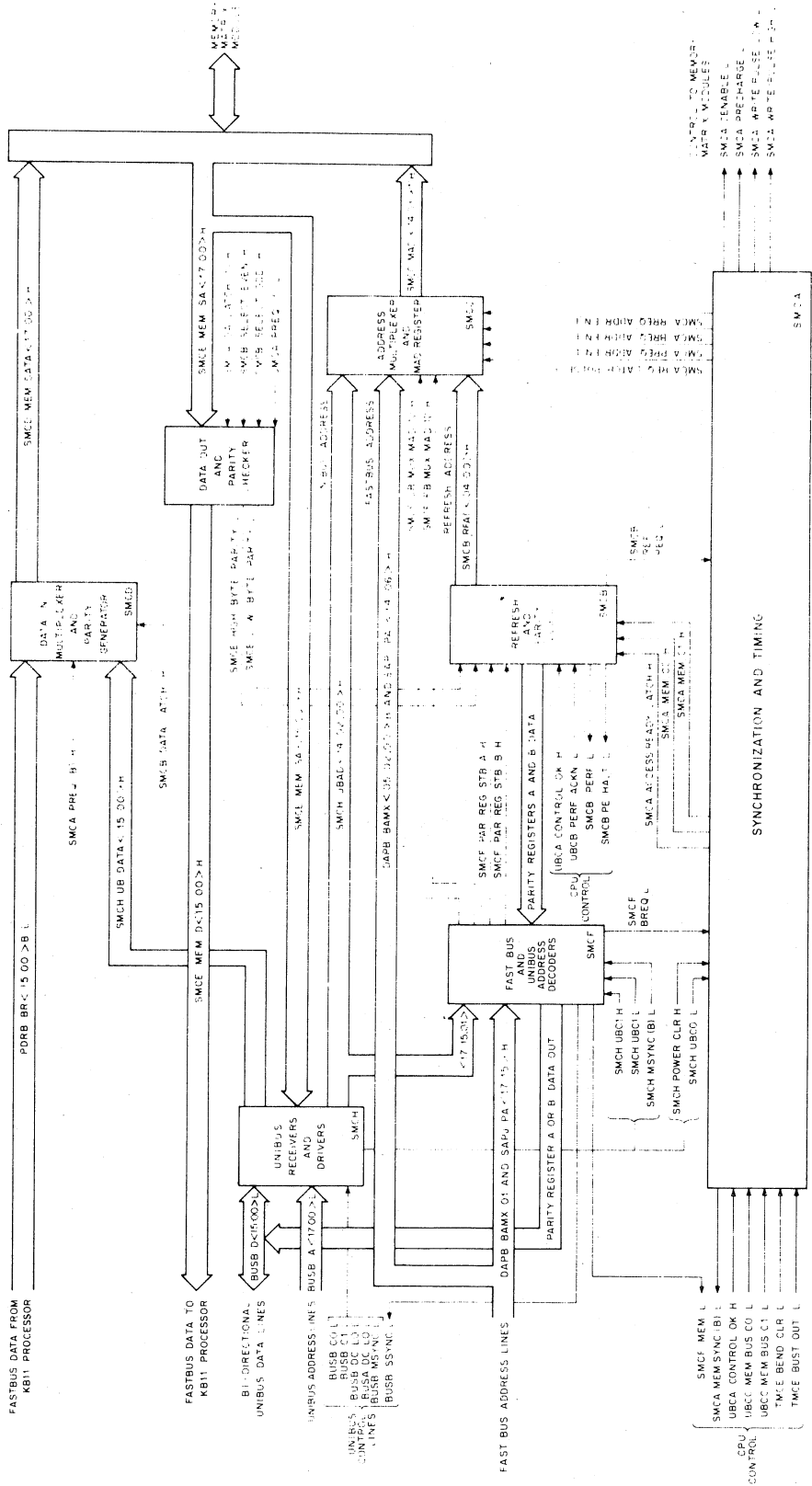

M8110 Semiconductor Memory Control Module, Block Diagram

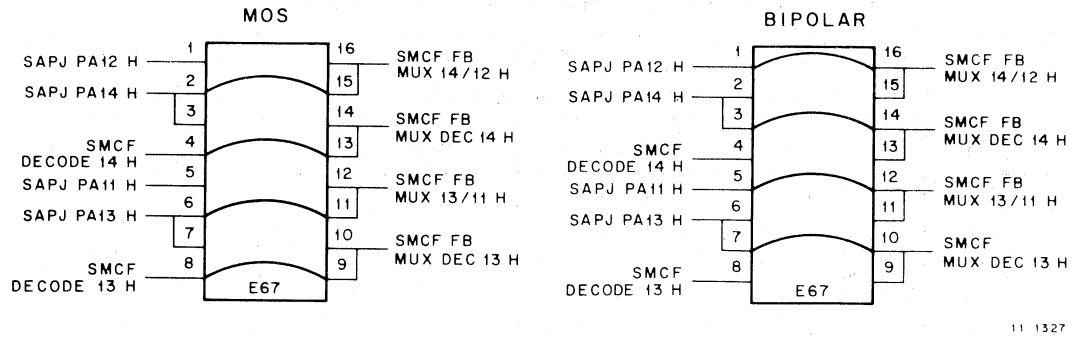

11-1327

Fastbus Address Multiplexing (14:11), Required E67 Jumpers

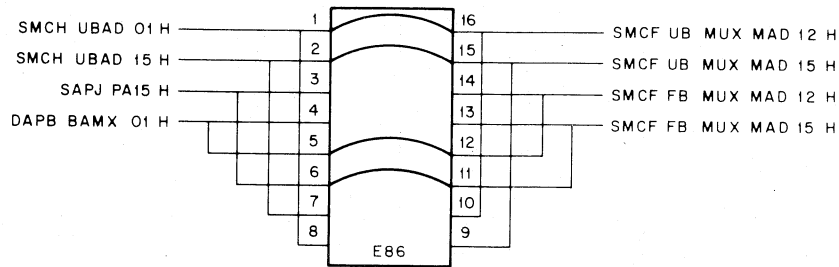

11-1328

MAD Multiplexing, Required E86 Jumpers

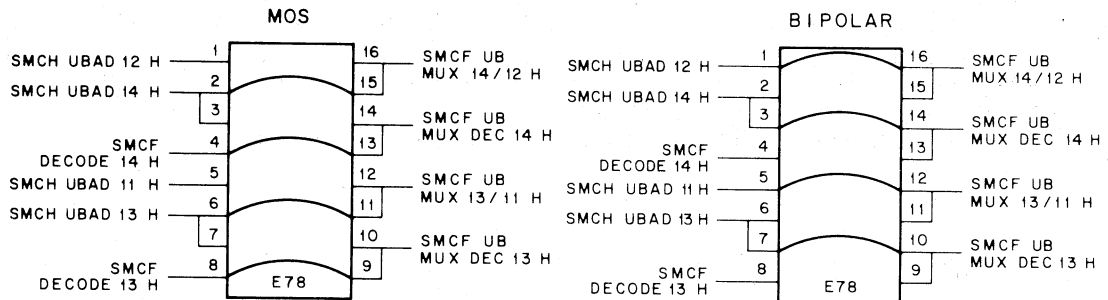

11-1329

Unibus Address Multiplexing (14:11), Required E78 Jumpers

Fastbus/Unibus Memory Address (Assign and Decode)

Fastbus/Unibus Address Decoder Bits					Memory Address Assignment		M8110 Jumpers (E87) (NOTE 1, NOTE 2)				
17	16	15	14	13	Bipolar	MOS	C	D	E	F	H
0	0	0	0	0	0-4K	0-16K					
0	0	0	0	1	4-8K						X
0	0	0	1	0	8-12K					X	
0	0	0	1	1	12-16K					X	X
0	0	1	0	0	16-20K	16-32K			X		
0	0	1	0	1	20-24K				X		X
0	0	1	1	0	24-28K				X	X	
0	0	1	1	1	28-32K				X	X	X
0	1	0	0	0	32-36K	32-48K		X			
0	1	0	0	1	36-40K			X			X
0	1	0	1	0	40-44K			X		X	
0	1	0	1	1	44-48K			X		X	X
0	1	1	0	0	48-52K	48-64K		X	X		
0	1	1	0	1	52-56K			X	X		X
0	1	1	1	0	56-60K			X	X	X	
0	1	1	1	1	60-64K			X	X	X	X
1	0	0	0	0	64-68K	64-80K	X				
1	0	0	0	1	68-72K		X				X
1	0	0	1	0	72-76K		X			X	
1	0	0	1	1	76-80K		X			X	X
1	0	1	0	0	80-84K	80-96K	X		X		
1	0	1	0	1	84-88K		X		X		X
1	0	1	1	0	88-92K		X		X	X	
1	0	1	1	1	92-96K		X		X	X	X
1	1	0	0	0	96-100K	96-112K	X	X			
1	1	0	0	1	100-104K		X	X			X
1	1	0	1	0	104-108K		X	X		X	
1	1	0	1	1	108-112K		X	X		X	X
1	1	1	0	0	112-116K	112-128K	X	X	X		
1	1	1	0	1	116-120K		X	X	X		X
1	1	1	1	0	120-124K		X	X	X	X	
1	1	1	1	1	124-128K		X	X	X	X	X

- NOTES:
1. "X" denotes jumper to be cut.
 2. Jumpers F and H are left intact for all MOS memory assignments.

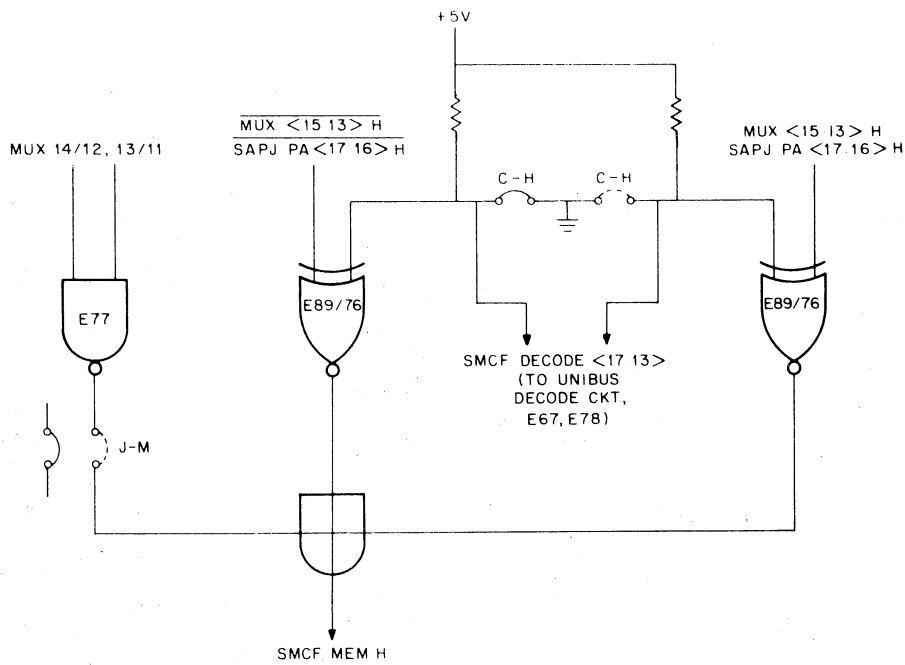

11-1326

Simplified Memory Address Decode (SMCF)

MOS/Bipolar Module Addressing

Fastbus/Unibus Memory Address Bits		Memory Address Assignment		Remove Jumpers	
FB MUX 14/12	FB MUX 13/11	MOS	Bipolar	Fastbus Address Select	Unibus Address Select
0	0	0-4095	0- 1023	J	N
0	1	4096-8191	1024-2047	K	P
1	0	8192-12287	2048-3071	L	R
1	1	12288-16383	3072-4095	M	S

MOS/Bipolar Memory Addressing

No. of Memory Modules in Memory*	Memory Capacity		Remove Jumpers	
	MOS	Bipolar	Fastbus Address Select	Unibus Address Select
1	4K	1K	J	N
2	8K	2K	JK	NP
3	12K	3K	JKL	NPR
4	16K	4K	JKLM	NPRS

*Connected to one M8110 Control.

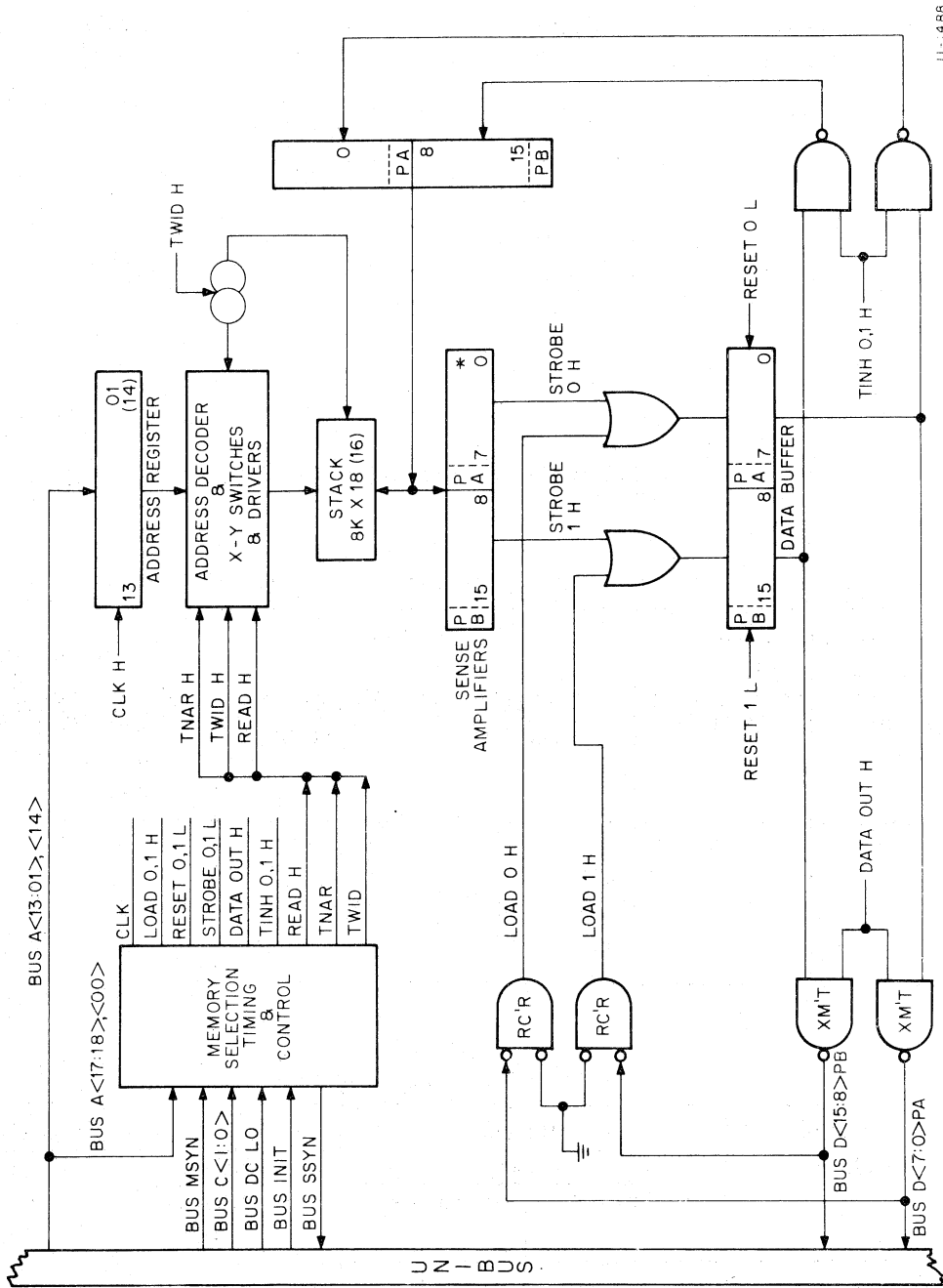

MM-11 S. Simplified Block Diagram

Memory Bank (words)	Machine Address (words)	Device Address Jumpers (1)			
		W6 A14 or A01 (2)	W4 A15	W3 A16	W2 A17L
0-8K	00000-037776	In	In	In	In
8-16K	040000-077776	Out	In	In	In
16-24K	100000-137776	In	Out	In	In
24-32K	140000-177776	Out	Out	In	In
32-40K	200000-237776	In	In	Out	In
40-48K	240000-277776	Out	In	Out	In
48-56K	300000-337776	In	Out	Out	In
56-64K	340000-377776	Out	Out	Out	In
64-72K	400000-437776	In	In	In	Out
72-80K	440000-477776	Out	In	In	Out
80-88K	500000-537776	In	Out	In	Out
88-96K	540000-577776	Out	Out	In	Out
96-104K	600000-637776	In	In	Out	Out
104-112K	640000-677776	Out	In	Out	Out
112-120K	700000-737776	In	Out	Out	Out
120-128K	740000-767776	Out	Out	Out	Out

- (1) W5 and W10 must be installed and W9 must be removed.
- (2) The memory can be interleaved as 16K only, using two adjacent contiguously addressed 8K banks. When two 8K banks are interleaved, jumpers W7 and W8 must be in the configuration shown by the dotted lines. Bit A01 goes to the device selector gate controlled by jumper W6. One 8K bank must have W6 installed and the other must have W6 removed. When not interleaved, jumpers W7 and W8 must be in the configuration shown by the solid lines. Bit A14 goes to the device selector gate controlled by jumper W6.

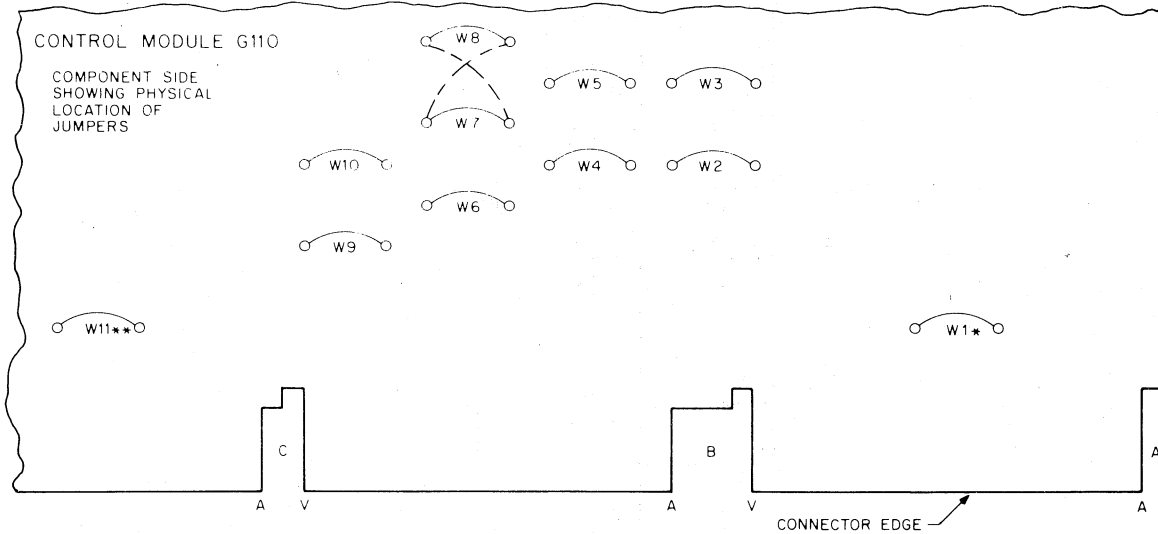
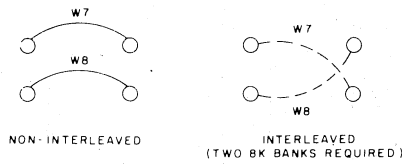

* Jumper W1 is for test purposes only. It must be installed for normal operation.

** Jumper W11 should be removed for normal operation. When installed the memory responds to DAT1 only, regardless of state of control lines CO0 and CO1.

NOTE:
Jumpers W5, W7, and W8 must remain in the factory installed positions.

Device Decoding Guide

MEMORY

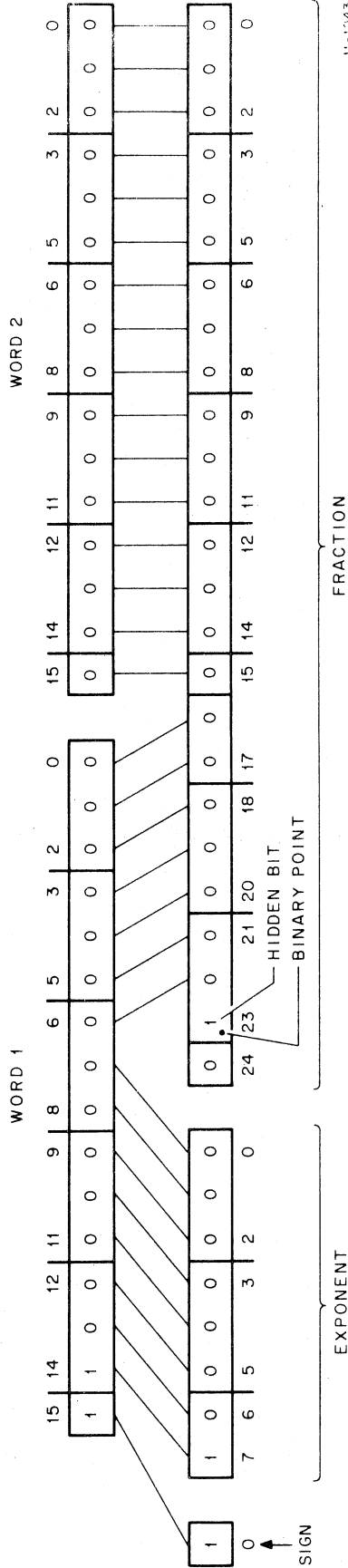

11-1043

FP11

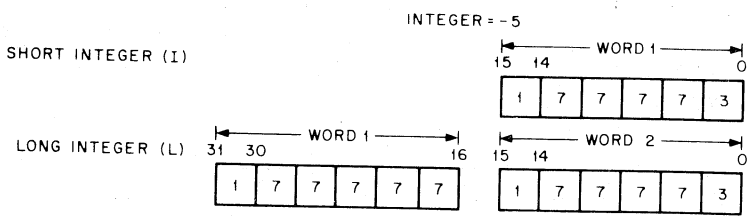
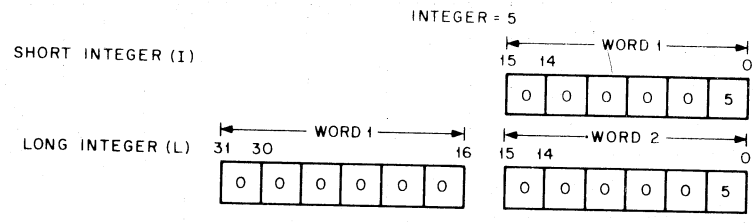

11-0801

Integer Formats

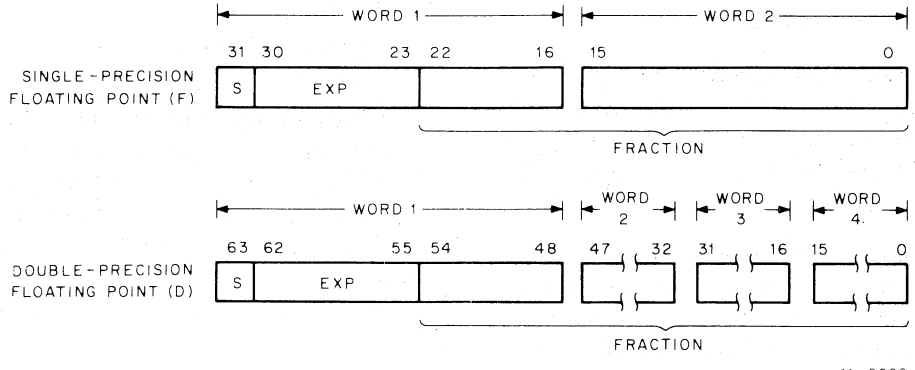

11-0802

- S = Sign
- EXP = Exponent in excess 200₈ notation
- Fraction = 23 or 55 bit fraction in sign and magnitude format.
- Binary point between bits 22 and 23 for F format or between bits 54 and 55 for D format.

Floating-Point Data Formats

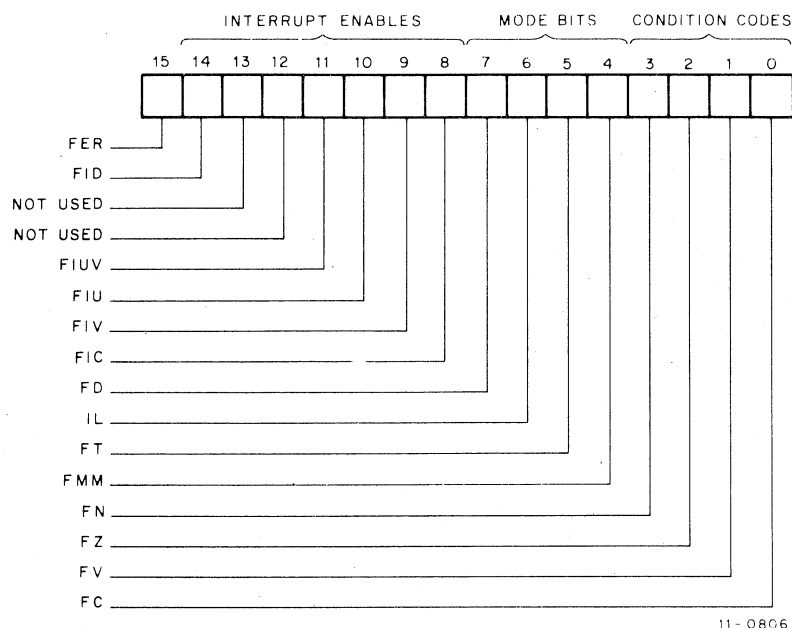

Status Register Format

FER – This bit indicates an error condition of the FP11.

FID (Floating Interrupt Disable) – All interrupts by the FP11 are disabled when this bit is on.

FIUV (Floating Interrupt on Undefined Variable) – When this bit is set and a minus 0 is obtained from memory, an interrupt occurs. If the bit is not set, minus 0 can be loaded and stored; however, any arithmetic operation is treated as if it were a positive 0.

FIU (Floating Interrupt on Underflow) – When this bit is set, an underflow condition causes a floating underflow interrupt. The result of the operation causing the interrupt is correct except for the exponent, which is off by 400_8 . If the FIU bit is not set and underflow occurs, the result is set to zero.

FIV (Floating Interrupt on Overflow) – When this bit is set, floating overflow causes an interrupt. The result of the operation causing the interrupt is correct except for the exponent, which is off by 400_8 . If the FIV bit is not set, the result of the operation is the same; the only difference is that the interrupt does not occur.

FIC (Floating Interrupt on Integer Conversion Error) – When this bit is set, and the Store Convert Floating to Integer instruction causes FC to be set (indicating a conversion error), an interrupt occurs. When a conversion error occurs, the destination register is cleared and the source register is untouched. When FIC is reset, the

result of the operation is the same; however, no interrupt occurs.

FD (Double-Precision Mode Bit) – This bit, when set, specifies double-precision format and, when reset, specifies single-precision format.

IL (Long-Precision Integer Mode Bit) – This bit is employed during conversion between integer and floating-point format. If set, double-precision, 2's complement integer format of 32 bits is specified; if reset, single-precision 2's complement integer of 16 bits is specified.

FT (Truncate Bit) – This bit, when set, causes the result of any floating-point operation to be truncated rather than rounded.

FMM (Maintenance Mode Bit) – This bit is used to enable special maintenance logic.

FC, FV, FZ, and FN – These bits are the four floating-point condition codes, which can be loaded in the CPU's C, V, Z, and N condition codes, respectively. This is accomplished by the Copy Floating Condition Codes (CFCC) instruction. To determine how each instruction affects the condition codes, refer to the instruction description in the *PDP-11 Handbook*.

For the Store Convert Floating to Integer instruction (which converts a floating-point number to an integer), the FC bit is set if the resulting integer is too large to be stored in the specified register.

PROCESSING OF FLOATING-POINT EXCEPTIONS

A total of seven possible interrupts can occur. These seven possible interrupt exceptions are encoded in the FP11 Exception Code Register (FEC). The interrupt exception codes represent an offset into a dispatch table, which routes the program to the right error handling routine. The dispatch table is a function of the software. The offset for each exception code is shown below followed by a brief description.

FP11 Exception Code (Base 8)	Definition
2	Floating Op Code Error -- The FP11 causes an interrupt for an erroneous op code if the FID bit is not set.
4	Floating Divide by Zero -- Division by zero causes an interrupt if the FID bit is not set.
6	Floating Integer Conversion Error
10	Floating Overflow
12	Floating Underflow
14	Floating Undefined Variable
16	Microbreak Trap

NOTE

The traps for exception codes 6, 10, 12, and 14 can be enabled in the FPU's Program Status Register.

In addition to the FEC register, the FP11 contains a 16-bit Floating Exception Address register (FEA), which stores the address of the last floating-point instruction that caused a floating-point exception.

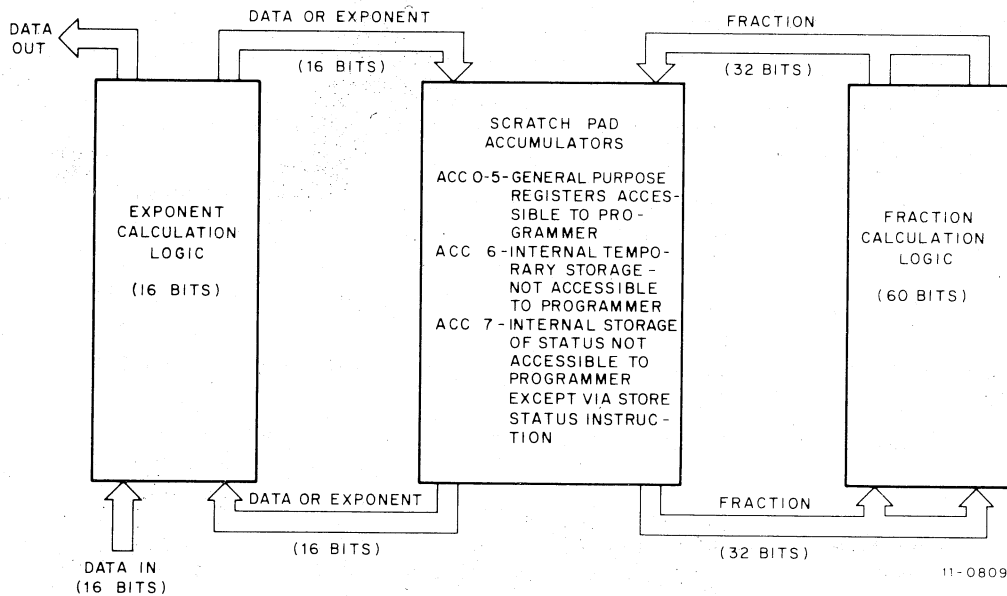

FP11 Simplified Block Diagram

FP11 INSTRUCTION FORMATS

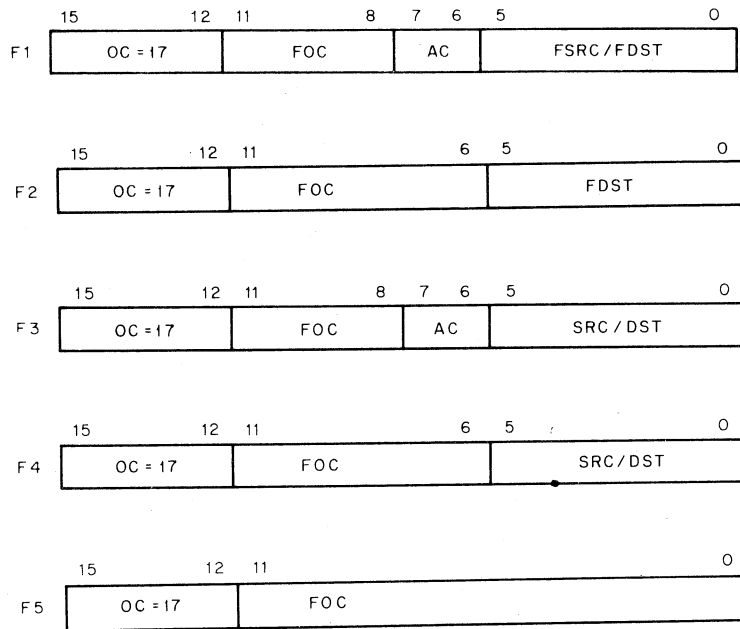

11-0800

The 2-bit AC field (bits 6 and 7) allows selection of scratch pad accumulators 0 through 3 only. If address mode 0 is specified with formats F1 or F2, bits 2 through 0 are used to select the floating-point accumulator. Only accumulators 5 through 0 can be accessed in this manner. If accumulators 6 or 7 are specified, the FP11 traps if the interrupt is enabled.

The fields of the various instruction formats

Mnemonic	Description
OC	Operation Code – All floating-point instructions are designated by a 4-bit op code of 17_8 .
FOC	Floating Operation Code – The number of bits in this field varies with the format and is used to specify the actual floating-point operation.
SRC	Source – A 6-bit source field identical to that in a PDP-11 instruction.
DST	Destination – A 6-bit destination field identical to that in a PDP-11 instruction.
FSRC	Floating Source – A 6-bit field used only in format F1. It is identical to SRC, except in mode 0 when it references a floating-point accumulator rather than a CPU general register.
FDST	Floating Destination – A 6-bit field used in formats F1 and F2. It is identical to DST, except in mode 0 when it references a floating-point accumulator instead of a CPU general register.
AC	Accumulator – A 2-bit field used only in formats F3 and F1 to specify accumulators 0 through 3.

Instruction Format	Instruction	Mnemonic
F1 ↑ ↓ F1	ADD LOAD SUBTRACT COMPARE MULTIPLY MODULO STORE DIVIDE LOAD CONVERT STORE CONVERT	ADDF FSRC, AC ADDD FSRC, AC LDF FSRC, AC LDD FSRC, AC SUBF FSRC, AC SUBD FSRC, AC CMPF AC, FDST CMPD AC, FDST MULF FSRC, AC MULD FSRC, AC MODF FSRC, AC MODD FSRC, AC STF AC, FDST STD AC, FDST DIVF FSRC, AC DIVD FSRC, AC LDCFD FSRC, AC LDCDF FSRC, AC STCFD AC, FDST STCDF AC, FDST
F2 ↑ ↓ F2	CLEAR TEST ABSOLUTE NEGATE	CLR F DST CLR D DST TST F DST TST D DST ABS F DST ABS D DST NEG F DST NEG D DST
F3 ↑ ↓ F3	LOAD EXPONENT LOAD CONVERT INTEGER TO FLOATING STORE EXPONENT STORE CONVERT FLOATING TO INTEGER	LDEXP SRC, AC LCDIF SRC, AC LDCID SRC, AC LCDLF SRC, AC LDCLD SRC, AC STEXP AC, DST STCFI AC, DST STCFL AC, DST STCDI AC, DST STCDL AC, DST
F4 ↔ F4 F5 ↑ ↓ F5	LOAD FP11's PROGRAM STATUS STORE FP11's PROGRAM STATUS STORE FP11's STATUS COPY FLOATING CONDITION CODES SET FLOATING MODE SET INTEGER MODE LOAD UBREAK REGISTER LOAD SHIFT COUNTER STORE AR REGISTER IN AC0 MAINTENANCE RIGHT SHIFT STORE QR REGISTER IN AC0 SET DOUBLE MODE SET LONG INTEGER MODE	LDFPS SRC STFPS DST STST DST CFCC SETF SETI LDUB LDSC STA0 MRS ST00 SET D SET L

**DOUBLE OPERAND INSTRUCTIONS: OPR FSRC, AC
OPR AC, FDST**

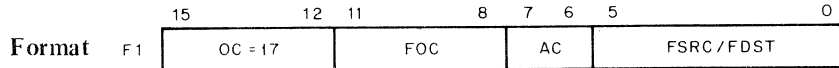

Mnemonic	Instruction/Operation	OP Code
MULF FSRC, AC MULD FSRC, AC	Floating Multiply $AC \leftarrow (AC) * (FSRC)$ if $[(AC) * (FSRC)] \geq LOLIM$; else $AC \leftarrow 0$ $FC \leftarrow 0$ $FV \leftarrow 1$ if $(AC) > UPLIM$; else $FV \leftarrow 0$ $FZ \leftarrow 1$ if $(AC) = 0$; else $FZ \leftarrow 0$ $FN \leftarrow 1$ if $(AC) < 0$; else $FN \leftarrow 0$	$171000 + AC * 100 + FSRC$
MODF FSRC, AC MODD FSRC, AC	Floating Modulo $AC \vee 1 \leftarrow$ integer part of $[(AC) * (FSRC)]$ $AC \leftarrow$ fractional part of $(AC) * (FSRC) - (AC \vee 1)$ if $ [(AC) * (FSRC)] \geq LOLIM$ or $FIU = 1$; else $AC \leftarrow 0$ $FC \leftarrow 0$ $FV \leftarrow 1$ if $(AC) > UPLIM$; else $FV \leftarrow 0$ $FZ \leftarrow 1$ if $(AC) = 0$; else $FZ \leftarrow 0$ $FN \leftarrow 1$ if $(AC) < 0$; else $FN \leftarrow 0$ The product of (AC) and $(FSRC)$ is 48 bits in single-precision floating-point format or 59 bits in double-precision floating-point format. The integer part of the product $[(AC) * (FSRC)]$ is found and stored in $AC \vee 1$. The fractional part is then obtained and stored in AC . Note that multiplication by 10 can be done with zero error, allowing decimal digits to be stripped off with no loss in precision.	$171400 + AC * 100 + FSRC$
ADDF FSRC, AC ADDD FSRC, AC	Floating Add $AC \leftarrow (AC) + (FSRC)$ if $[(AC) + (FSRC)] > UPLIM$ else $AC \leftarrow 0$ $FC \leftarrow 0$ $FV \leftarrow 1$ if $(AC) > UPLIM$; else $FV \leftarrow 0$ $FZ \leftarrow 1$ if $(AC) = 0$; else $FZ \leftarrow 0$ $FN \leftarrow 1$ if $(AC) < 0$; else $FN \leftarrow 0$	$172000 + AC * 100 + FSRC$
LDF FSRC, AC LDD FSRC, AC	Floating Load $AC \leftarrow (FSRC)$ $FC \leftarrow 0$ $FV \leftarrow 0$ $FZ \leftarrow 1$ if $(AC) = 0$; else $FZ \leftarrow 0$ $FN \leftarrow 1$ if $(AC) < 0$; else $FN \leftarrow 0$	$172400 + AC * 100 + FSRC$
SUBF FSRC, AC SUBD FSRC, AC	Floating Subtract $AC \leftarrow (AC) - (FSRC)$ if $[(AC) - (FSRC)] \geq LOLIM$ else $AC \leftarrow 0$ $FC \leftarrow 0$ $FV \leftarrow 1$ if $(AC) > UPLIM$; else $FV \leftarrow 0$ $FZ \leftarrow 1$ if $(AC) = 0$; else $FZ \leftarrow 0$ $FN \leftarrow 1$ if $(AC) < 0$; else $FN \leftarrow 0$	$173000 + AC * 100 + FSRC$

DOUBLE OPERAND INSTRUCTIONS: OPR FSRC, AC (Cont.)
OPR AC, FDST

Mnemonic	Instruction/Operation	OP Code
CMPF FSRC, AC CMPD FSRC, AC	Floating Compare (FSRC) - (AC) FC ← 0 FV ← 0 FZ ← 1 if (FSRC) - (AC) = 0; else FZ ← 0 FN ← 1 if (FSRC) - (AC) < 0; else FN ← 0	173400 + AC * 100 + FDST
STF AC, FDST STD AC, FDST	Floating Store FDST ← (AC) FC ← FC FV ← FV FZ ← FZ FN ← FN	174000 + AC * 100 + FDST
DIVF FSRC, AC DIVD FSRC, AC	Floating Divide AC ← (AC)/(FSRC) if [(AC)/(FSRC)] > LOLIM; else AC ← 0 FC ← 0 FV ← 1 if (AC) > UPLIM FZ ← 1 if (AC) = 0; else FZ ← 0 FN ← 1 if (AC) < 0; else FN ← 0	174400 + AC * 100 + FSRC
STCFD AC, FDST STCDF AC, FDST	Store Convert from Floating to Double or Double to Floating FDST ← C _{F,D} ∨ D _F (AC) FC ← 0 FV ← 1 if (AC) > UPLIM; else FV ← 0 FZ ← 1 if (AC) = 0; else FZ ← 0 FN ← 1 if (AC) < 0; else FN ← 0	176000 + AC * 100 + FDST F,D – single-precision to double-precision floating D,F – double-precision to single-precision floating
LDCDF FSRC, AC LDCFD FSRC, AC	Load Convert Double to Floating or Floating to Double AC ← C _{F,D} ∨ D _F (FSRC) FC ← 0 FV ← 1 if (AC) > UPLIM; else FV ← 0 FZ ← 1 if (AC) = 0; else FZ ← 0 FN ← 1 if (AC) < 0; else FN ← 0 If the current format is single-precision floating-point (FD = 0), the source is assumed to be a double-precision number and is converted to single precision. If the floating truncate bit is set the number is truncated; otherwise, it is rounded. If the current format is double-precision (FD = 1), the source is assumed to be a single-precision number and is loaded left justified in the AC. the lower half of the AC is cleared.	177400 + AC * 100 + FSRC F,D – single-precision to double-precision floating D,F – double-precision to single-precision floating

SINGLE OPERAND INSTRUCTIONS: OPR FDST

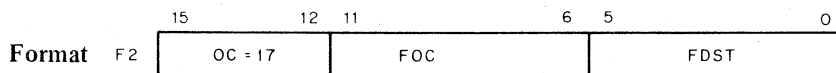

Mnemonic	Instruction/Operation	OP Code
CLRF FDST CLR D FDST	Clear FDST ← 0 FC ← 0 FV ← 0 FZ ← 1 FN ← 0	170400 + FDST
TSTF FDST TST D FDST	Test FDST ← (FDST) FC ← 0 FV ← 0 FZ ← 1 if (FDST) = 0; else FZ ← 0 FN ← 1 if (FDST) < 0; else FN ← 0	170500 + FDST
ABSF FDST ABS D FDST	Absolute FDST ← – (FDST) if (FDST) < 0; else FDST ← (FDST) FC ← 0 FV ← 0 FZ ← 1 if (FDST) = 0; else FZ ← 0 FN ← 0	170600 + FDST
NEGF FDST NEG D FDST	Negate FDST ← – (FDST) FC ← 0 FV ← 0 FZ ← 1 if (FDST) = 0; else FZ ← 0 FN ← 1 if (FDST) < 0; else FN ← 0	170700 + FDST

**DOUBLE OPERAND INSTRUCTIONS: OPR SRC
OPR DST**

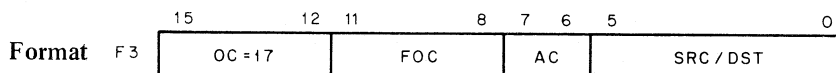

Mnemonic	Instruction/Operation	OP Code
STEXP AC, DST	Store Exponent DST ← AC EXPONENT – 200 FC ← 0 FV ← 0 FZ ← 1 if (DST) = 0; else FZ ← 0 FN ← 1 if (DST) < 0; else FN ← 0 C ← FC V ← FV Z ← FZ N ← FN	175000 + AC * 100 + DST

**DOUBLE OPERAND INSTRUCTIONS: OPR SRC (Cont.)
OPR DST**

Mnemonic	Instruction/Operation	OP Code
STCFI AC, DST STCFL AC, DST STCDI AC, DST STCDL AC, DST	<p>Store Convert from Floating to Integer Destination receives converted AC if the resulting integer number can be represented in 16 bits (short integer) or 32 bits (long integer). Otherwise, destination is zeroed and C bit is set.</p> <p>$FV \leftarrow 0$ $FZ \leftarrow 1$ if (DST) = 0; else $FZ \leftarrow 0$ $FN \leftarrow 1$ if (DST) < 0; else $FN \leftarrow 0$ $C \leftarrow FC$ $V \leftarrow FV$ $Z \leftarrow FZ$ $N \leftarrow FN$</p> <p>When the conversion is to long integer (32 bits) and address mode 0 or immediate mode is specified, only the most significant 16 bits are stored in the destination register.</p>	<p>175400 + AC * 100 + DST</p> <p>STCFI – Single float to single integer STCFL – Single float to long integer STCDI – Double float to single integer STCDL – Double float to long integer</p>
LDEXP SRC, AC	<p>Load Exponent $AC\ SIGN \leftarrow (AC\ SIGN)$ $AC\ EXP \leftarrow (SRC) + 200$ $AC\ FRACTION \leftarrow (AC\ FRACTION)$ $FC \leftarrow 0$ $FV \leftarrow 1$ if (AC) > UPLIM $FZ \leftarrow 1$ if (AC) = 0; else $FZ = 0$ $FN \leftarrow 1$ if (AC) < 0; else $FN = 0$</p>	<p>176400 + AC * 100 + SRC</p>
LDCIF SRC, AC LDCID SRC, AC LDCLF SRC, AC LDCLD SRC, AC	<p>Load and Convert from Integer to Floating $AC \leftarrow C_{FL,FD} (SRC)$ $FC \leftarrow 0$ $FV \leftarrow 0$ $FZ \leftarrow 1$ if (AC) = 0; else $FZ \leftarrow 0$ $FN \leftarrow 1$ if (AC) < 0; else $FN \leftarrow 0$</p> <p>$C_{FL,FD}$ specifies conversion from a 2's complement integer with precision I or L to a floating-point number of precision F or D. If integer flip-flop IL = 0, a 16-bit integer (I) is specified; if IL = 1, a 32 bit integer (L) is specified. If floating-point flip-flop FD = 0, a 32-bit floating-point number (F) is specified; if FD = 1, a 64-bit floating-point number (D) is specified. If a 32-bit integer is specified and addressing mode 0 or immediate mode is used, the 16-bits of the source register are left justified, and the remaining 16-bits are zeroed before the conversion.</p>	<p>177000 + AC * 100 + SRC</p> <p>LDCIF – single integer to single float LDCID – single integer to double float LDCLF – long integer to single float LDCLD – long integer to double float</p>

OPERATE INSTRUCTIONS: OPR

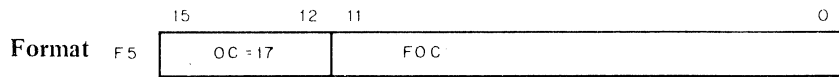

Mnemonic	Instruction/Operation	OP Code
CFCC	Copy Floating Condition Codes C ← FC V ← FV Z ← FZ N ← FN	170000
SETF	Set Floating Mode FD ← 0	170001
SETI	Set Integer Mode FL ← 0	170002
LDUB	Load Microbreak Register This instruction is a maintenance instruction in which the content of register R3 is gated into the UB register. When the control ROM address register matches the contents of the UB register, a scope sync is generated. If the FP11 is in maintenance mode (FMM=1), an interrupt is also generated and the FPU traps to the Ready state. A UB interrupt cannot be generated by the Ready state or by the states that are used to generate the UB interrupt.	170003
LDSC	Load Step Counter This is a maintenance instruction in which the content of register R4 is gated into the step counter, if the FP11 is in maintenance mode (FMM=1). Whenever the step counter is loaded by an LDSC, normal loading via the microprogram is inhibited until the step counter is incremented to zero. This allows partial quotients and products to be formed for diagnostic purposes. If FMM=0, the LDSC acts as a NOP.	170004
STAO	Store AR in AC0 AC0 (54:32) ← AR (57:35) if FD = 0 AC0 (54:0) ← AR (57:3) if FD = 1	170005
MRS	Maintenance Right Shift AR ← AR/2; QR ← QR/2	170006
STQ0	Store QR in AC0 BR ← QR; AC (54:32) ← BR (57:35) if FD = 0 AC0 (54:0) ← BR (57:3) if FD = 1	170007
SETD	Set Floating Double Mode FD ← 1	170011
SETL	Set Long Integer Mode FL ← 1	170012

**SINGLE OPERAND INSTRUCTIONS: OPR SRC
OPR DST**

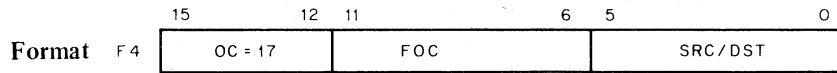

Mnemonic	Instruction/Operation	OP Code
LDFPS SRC	Load FP11's Program Status Word FPS ← (SRC)	170100 + SRC
STFPS DST	Store FP11's Program Status Word DST ← (FPS)	170200 + DST
STST DST	Store FP11's Status DST ← (FEC) DST + 2 ← (FEA) if not mode 0 or not immediate mode	170300 + DST

III Op Code	No Mem Class	Load Class	Store Class	Convert Special*
ROM 214	ROM 234	ROM 254	ROM 274	ROM 270
1. All illegal FP instruction	LDUB M0 LDF M0 STF M0 CLRf M0 LDSC M0 Neg F M0 ABSF ~ M0 TSTF M0 LDFDS M0 LDCIF M0 SETF M0 SETD M0 SETI M0 SETL M0 MRS M0 STQ0 M0 LDEXP M0 ADDF M0 SUBF M0 COMP M0 MULF M0 DIVF M0 LDCDF M0 LDCFD M0	ADDF ~ M0 SUBF ~ M0 COMPf ~ M0 MULF ~ M0 MODF ~ M0 DIV ~ M0 LDCDF ~ M0 LDF ~ M0 LDCFD ~ M0 LDCIF ~ M0 LDFPS ~ M0 CFCC *M0 ~ M0 NEGF ~ M0 ABSF ~ M0 TSTF ~ M0 LDEXP ~ M0	CLRf ~ M0 STF ~ M0 STCFD ~ M0 STFPS ~ M0 ~ M0 STST ~ M0 M0 STCFD ~ M0	STEXP STCFI STCFD
2. If address mode 0 in format F1 or F2 and ACj 6 or 7 selected				*Do conversion then use store F1.

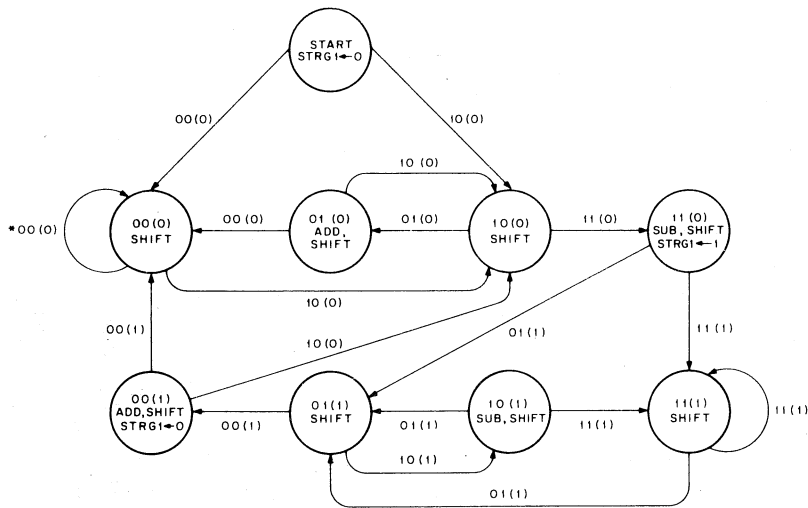

QR3(DBL)	QR2(DBL)	STRG1	FUNCTION
QR3(SNG)	QR34(SNG)		
0	0	0	RIGHT SHIFT QR, AR, INCREMENT SC**
0	1	0	$AR \leftarrow BR + AR$, RIGHT SHIFT QR, AR, INCREMENT SC
1	0	0	RIGHT SHIFT QR, AR, INCREMENT SC
1	1	0	$AR \leftarrow AR - BR$, RIGHT SHIFT QR, AR, SET STRG1, INCREMENT SC
0	0	1	$AR \leftarrow AR + BR$, RIGHT SHIFT QR, AR, RESET STRG1, INCREMENT SC
0	1	1	RIGHT SHIFT QR, AR, INCREMENT SC
1	0	1	$AR \leftarrow AR - BR$, RIGHT SHIFT QR, AR, INCREMENT SC
1	1	1	RIGHT SHIFT QR, AR INCREMENT SC

* For double precision format 00(0) = QR3, QR2, (STNG 1)
 For single precision format 00(0) = QR35, QR34, (STNG 1)

** The step counter is set to the two's complement of the number of bits in the multiplier and is checked for zero after each incrementation.

11-0437

Multiply State Diagram

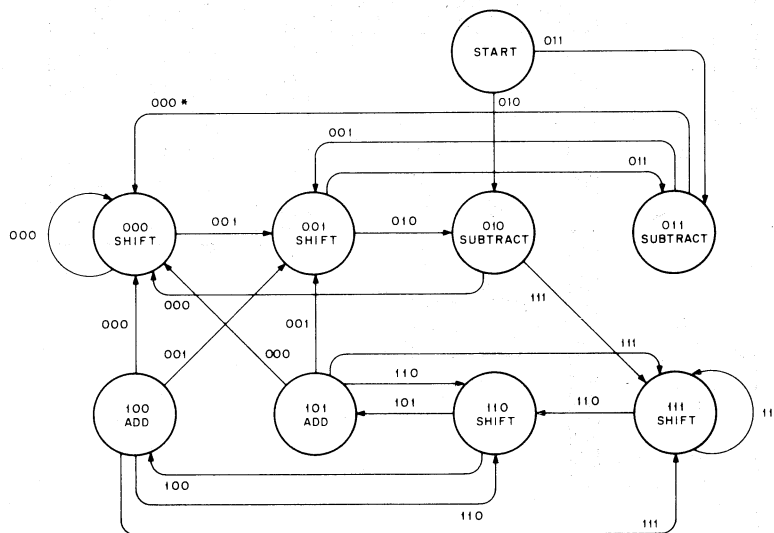

* Three digits shown throughout state diagram refer to bits AR59, 58, and 57
 For example,



NOTE
 BR is always positive and normalized

11-0443

State Diagram for Divide

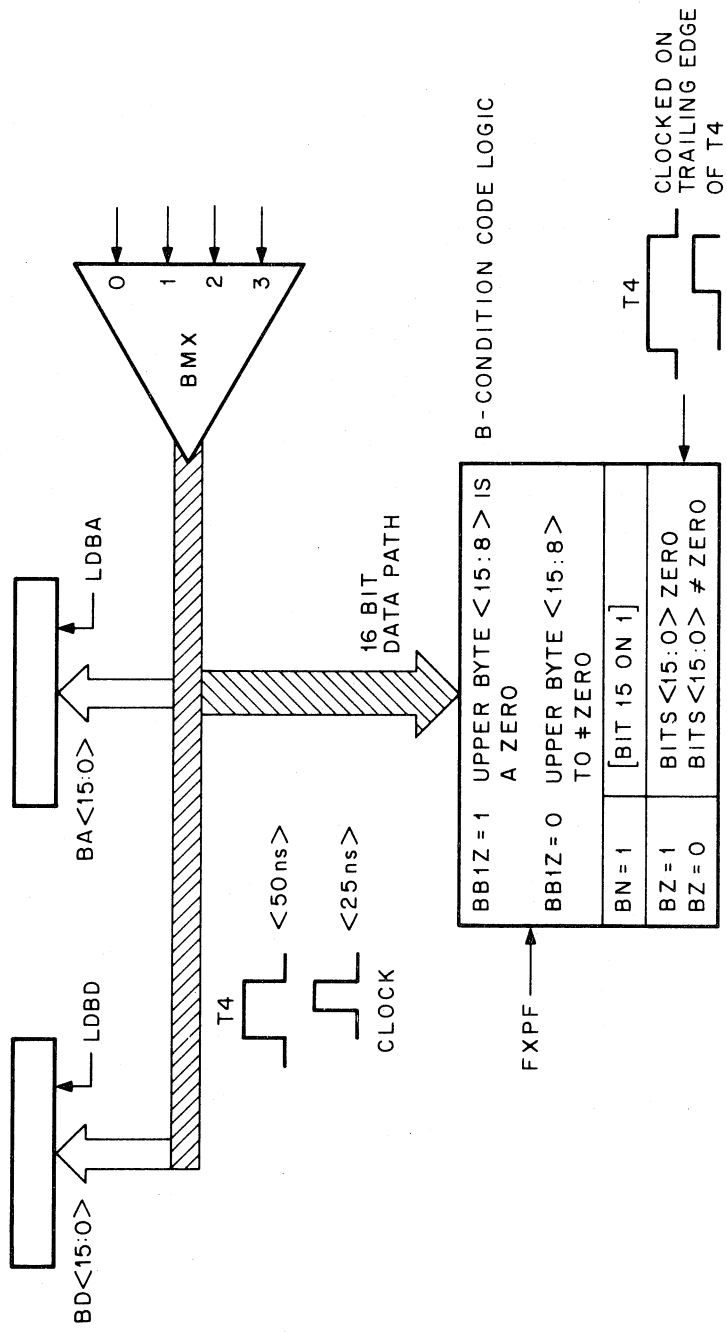

11-1490

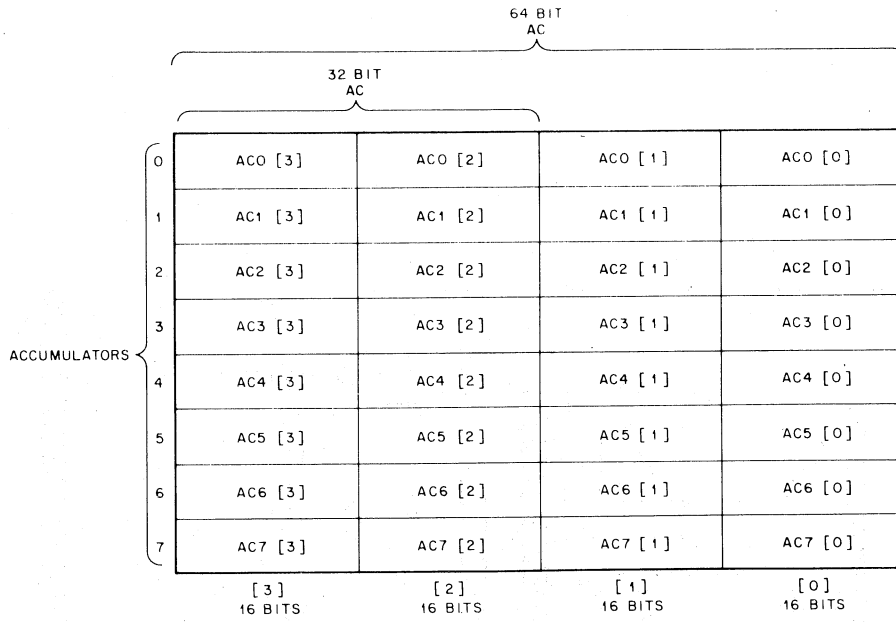

11-0805

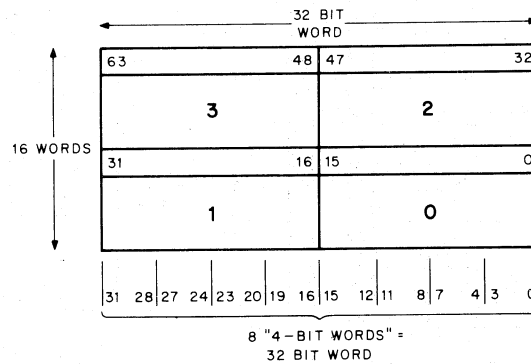

11-0854

ALU Control Field (ALUC3-ALUC0)	Function	ALU Select Lines				Mode ALUM	Carry in ALUC1		
		ALUS3	ALUS2	ALUS1	ALUS0				
0	~ A	0	0	0	0	1	X	Drive ALUS2 low	
1	~ (A V B)	0	0	0	1	1	X		
2	A minus B	0	1	1	0	0	0		
3	0	0	0	1	1	1	X		
4	~ (A ^ B)	0	1	0	0	1	X		
5	~ B	0	1	0	1	1	X		
6	A minus B minus 1	0	1	1	0	0	1		
7	A ^ ~ B	0	1	1	1	1	X		
10	A plus B plus 1	1	0	0	1	0	0		Drive ALUS0 low
11	A plus B	1	0	0	1	0	1		
12	B	1	0	1	0	1	X		
13	A ^ B	1	0	1	1	1	X		
14	1	1	1	0	0	1	X		
15	A minus 1	1	1	1	1	0	1		Drive ALUS1 low
16	A V B	1	1	1	0	1	X		
17	A	1	1	1	1	1	X		

X = don't care
0 = low
1 = high

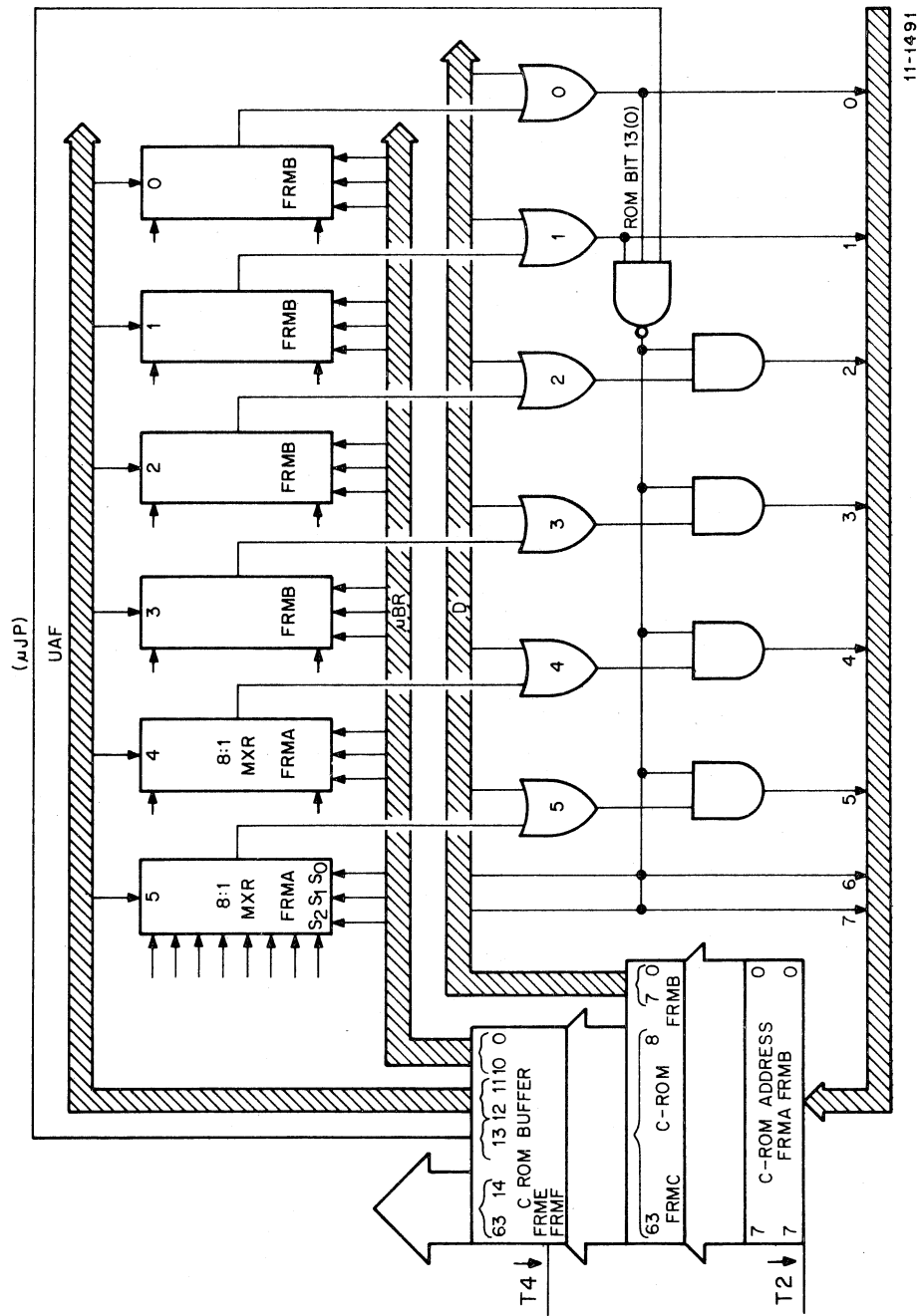

6-Bit Branch Bits

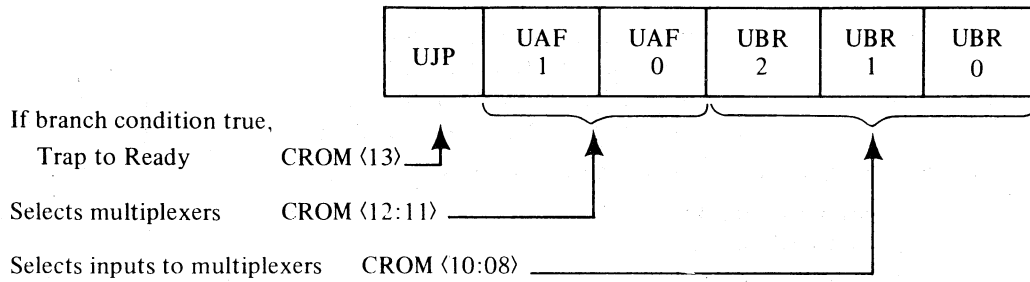

The three UBR bits are applied to each of the six multiplexers and uniquely specify one of the inputs to the multiplexer. If UBR bits 2, 1, and 0 are all 1s, the multiplexer output goes to 0, which indicates no modification takes place. For all other combinations, the multiplexer output goes to 1 if the selected branch condition is true. The UAF bits specify the multiplexer(s) as follows:

UAF1	UAF0	Multiplexers Selected
0	0	0 through 5 if UBR is even (UBR0 on a 0) 2 through 5 if UBR is odd (UBR0 on a 1)
0	1	0 Multiplexer selected
1	0	1 Multiplexer selected
1	1	Both 0 and 1 Multiplexers selected

Multiplexer Branching Conditions

	5	4	3	2	1	0
A	SUB FRAC	FIRD4	FIRD3	FIRD2	FIRD1	FIRD0
B	FIR07 (1)	FIR06 (1)	FIR11 (1)	FIR10 (1)	AR50 (0)	SD (1)
C	RNG2	RNG1	RNG0	0	BB1Z (1)	BN (0)
D	0	0	0	FIU (1)	IL (0)	Immediate
E	0	0	0	FT (1)	~(FC ^ FIC)	FD (0)
F	FIRD6	FIRD5	0	~ CONV SP	~(FVA FIV)	M0
G	0	0	FIR08 (0)	AR58 (0)	AR59 (0)	BZ (1)
H	0	0	0	0	0	0

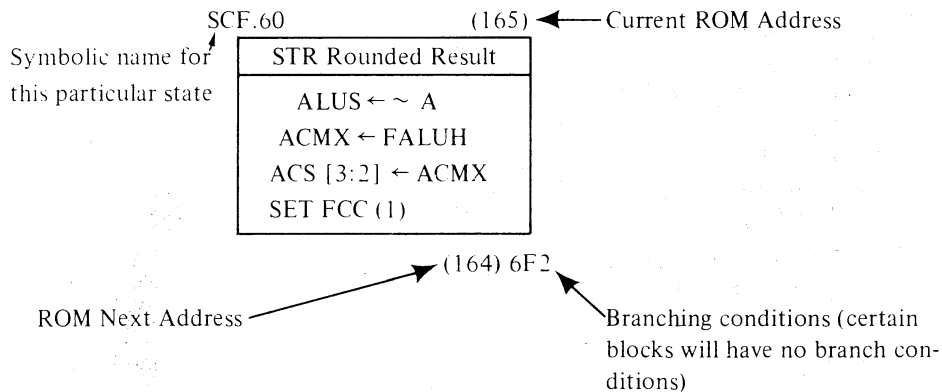

The branching conditions are designated as follows:

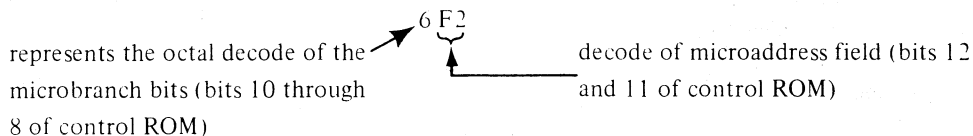

FRL	Fraction Data Path Low Order	M8115-0-01
FRH	Fraction Data Path High Order	M8114-0-01
FRM	FP ROM and ROM Control	M8112-0-01
FXP	Floating-Point Exponent Data Path	M8113-0-01

The FRL group of prints contains the following logic:

1. lower half of FALU
2. lower half of AR
3. lower half of BR
4. lower half of QR
5. floating-point status
6. ACMX
7. scratch pad (AC7-0)
8. BMX

The FRH group of prints contains the following logic:

1. upper half of FALU
2. upper half of AR
3. upper half of BR
4. upper half of QR
5. clock logic, times states, time pulses
6. sign of source (SS) and sign of destination (SD) logic
7. fractional control logic

The FRM group of prints contains the following logic:

1. control ROM
2. control ROM address register
3. Scratch pad addressing logic
4. ROM multiplexers
5. ROM data buffer
6. interfact logic

The FXP group of prints contains the following logic:

1. EALU
 2. EMX
 3. Step counter
 4. FIR
 5. BA register
 6. BD register
 7. U break register
 8. DIMX
 9. BRanching Logic
 10. Range ROM
 11. FRHE
1. MRI and MRO register
 2. MUL ARITH flip-flop
 3. Pause logic
 4. STRG I flip-flop
 5. AR control
 6. QR control
 7. MUL SUB flip-flop
 8. AR clock logic
 9. QR clock logic
 10. Sign bit

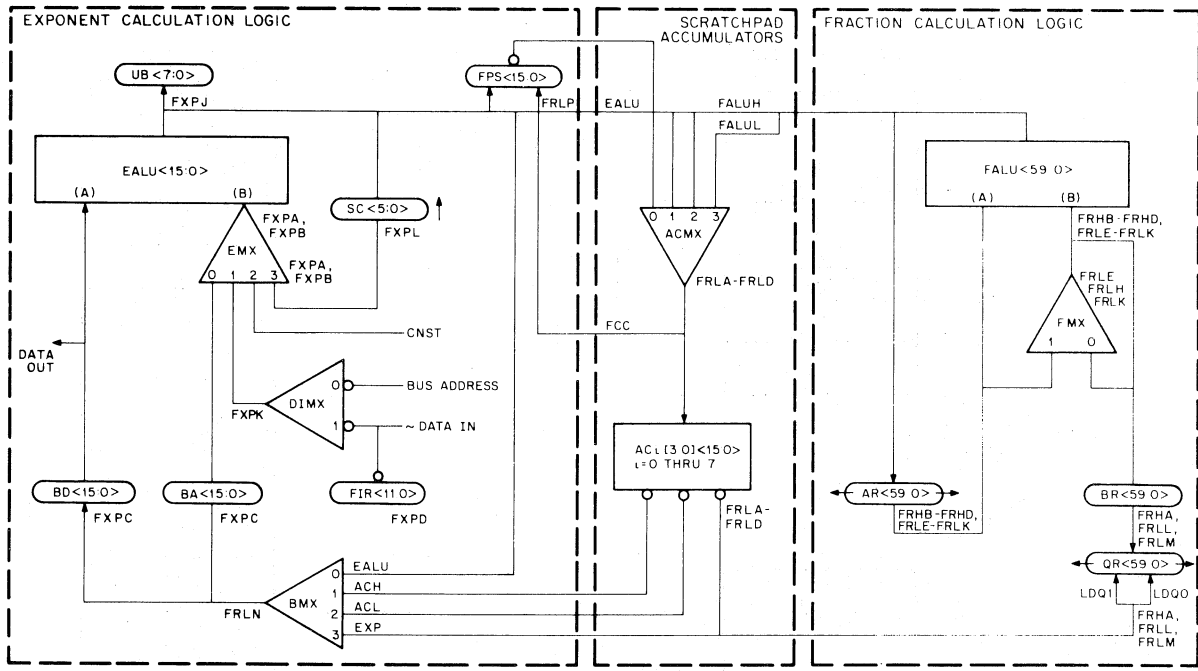

11-0820

DATA PATH DEFINITION

ACMX0 (31) ← ~BN; ACMX0 (30) ← BZ; ACMX0 (29:16) ← 37777; ACMX0 (15:0) ← FPS
 ACMX1 (31:16) ← EALU (15:00); ACMX1 (15:00) ← EALU (15:00)
 ACMX2 (31) ← ~SD; ACMX2 (30:23) ← EALU (07:00); ACMX2 (22:00) ← FALU (57:35)
 ACMX3 (31:00) ← FALU (34:03)

BMX0 (15:00) ← EALU (15:00)
 BMX1 (15:00) ← AC_i [3] (15:00) or AC_i [1] (15:00)
 BMX2 (15:00) ← AC_i [2] (15:00) or AC_i [0] (15:00)
 BMX3 (15:08) ← 0; BMX3 (07:00) ← AC_i [3:2] (30:23) or AC_i [01:0] (30:23)

EMX0 (15:00) ← BA (15:00)
 EMX1 (15:00) ← DIMX (15:00)
 EMX2 (15:00) ← CNST (15:00)
 EMX3 (15:06) ← 0; EMX3 (05:00) ← SC (05:00)

FMX0 (02) ← BR (35); FMX0 (01) ← BR (19); FMX0 (00) ← BR (3)
 FMX1 (02) ← AR (34); FMX1 (01) ← 1; FMX0 (00) ← AR (02)

LDQ1 = QR (59) ← 0; QR (58) ← 1 if AC_i [3:2] (30:24) ≠ 0 else QR (58) ← 0
 QR (57:35) ← AC_i [3:2] (22:0)
 LDQ0 = QR (34:3) ← AC_i [1:0] (31:0); QR (2:0) ← 0

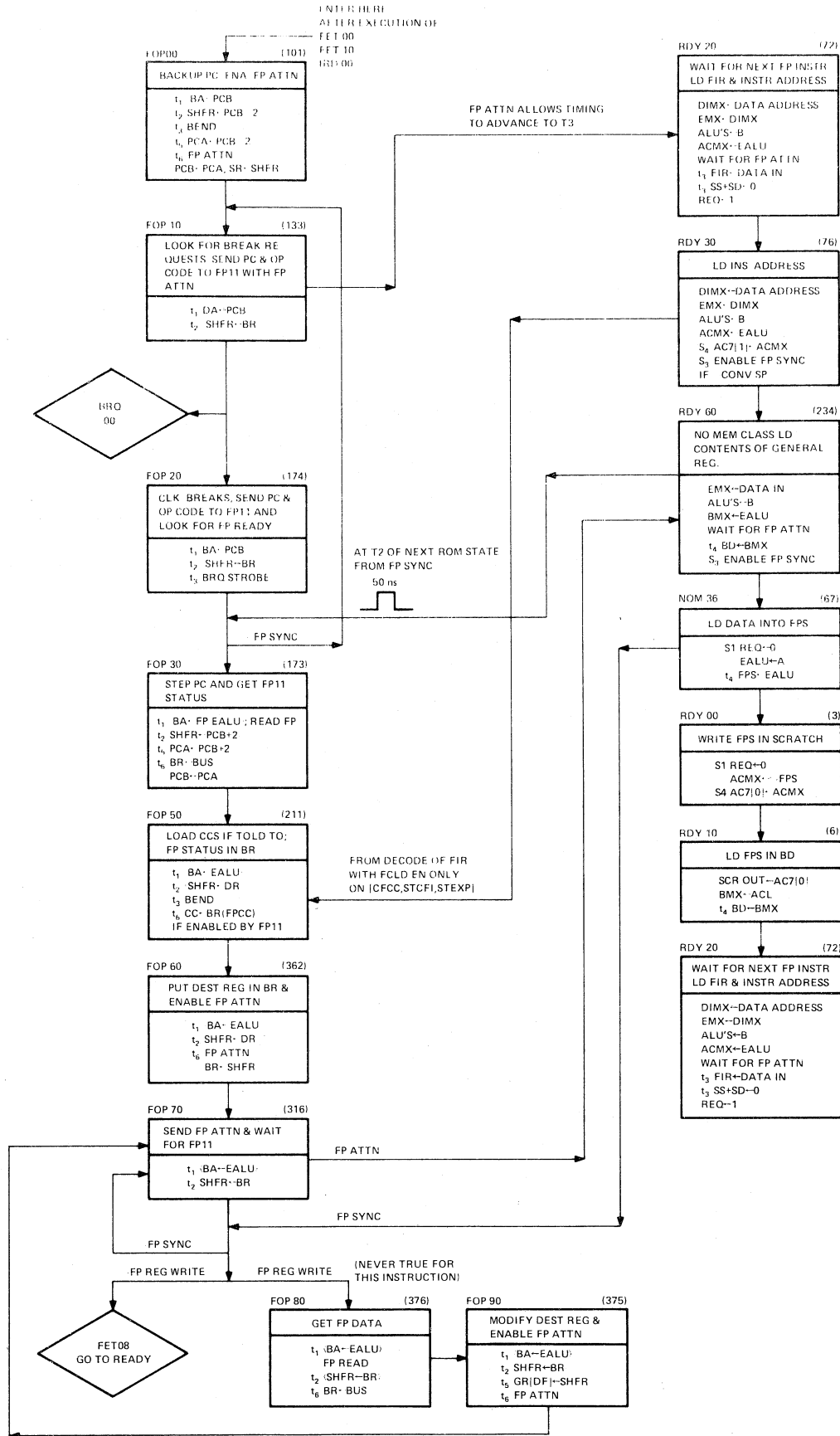

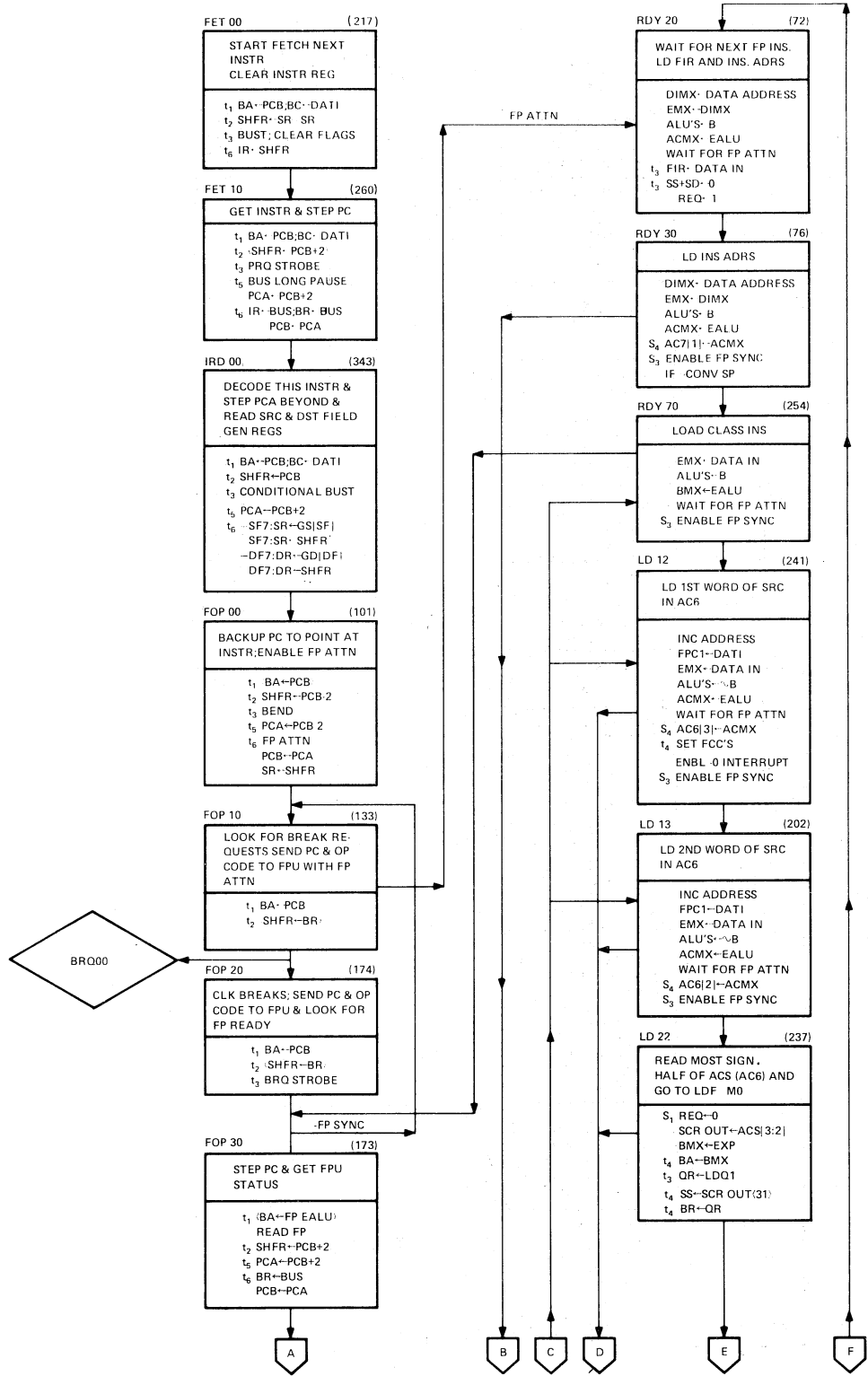

CP/FPP Interflow Mode 2 (sheet 1 of 2)

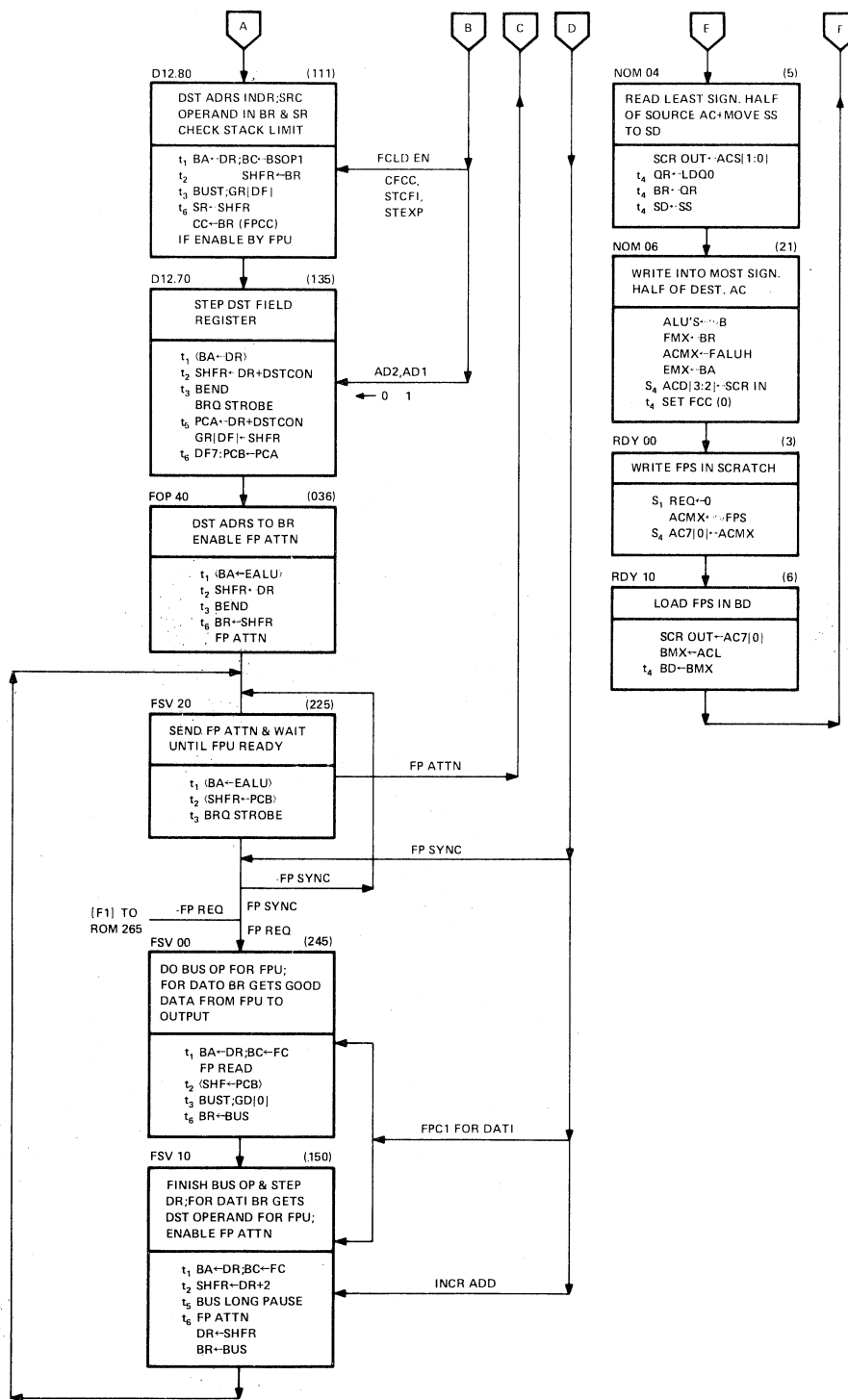

11-1442-B

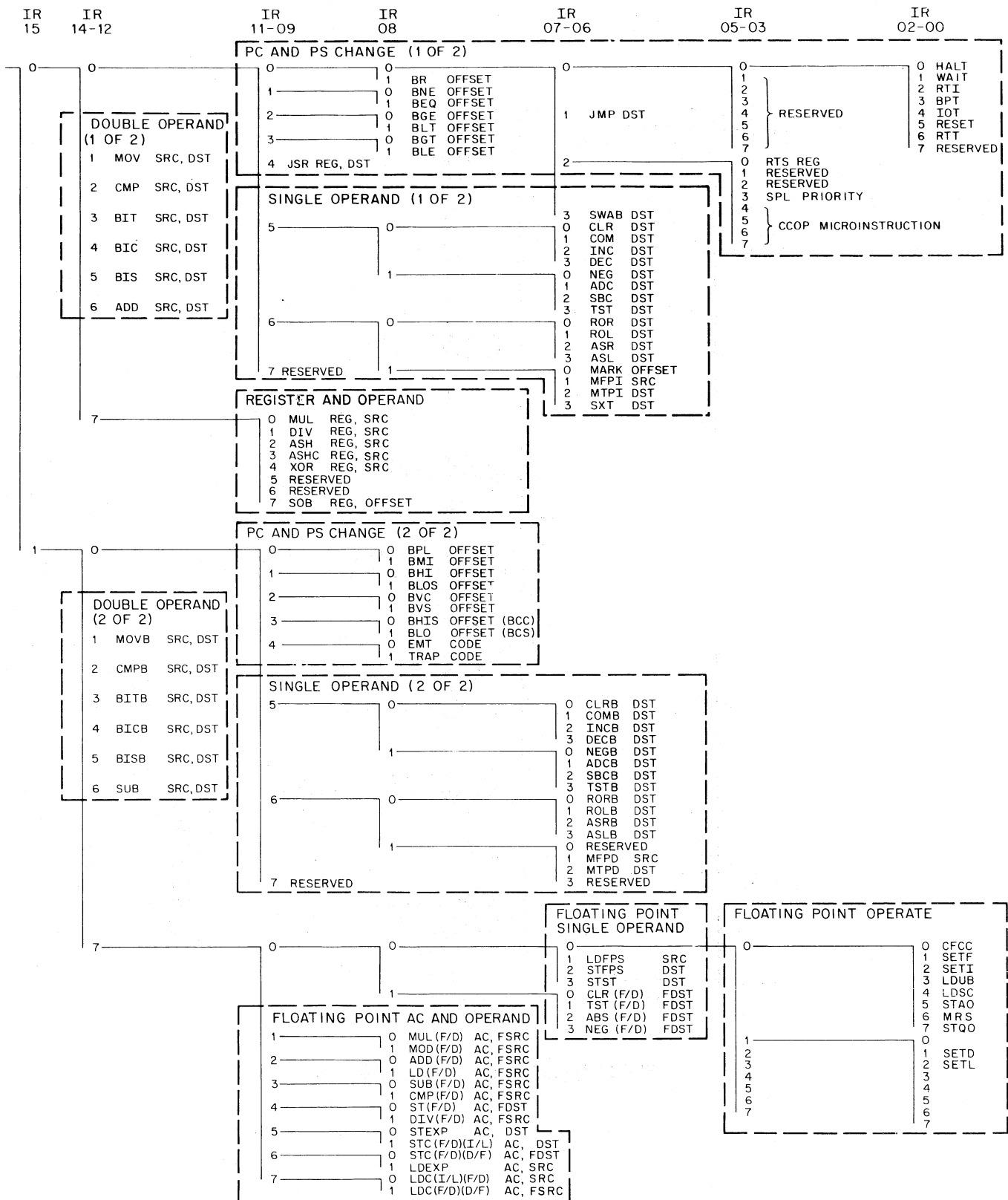

Determination of an Instruction from the Binary Code

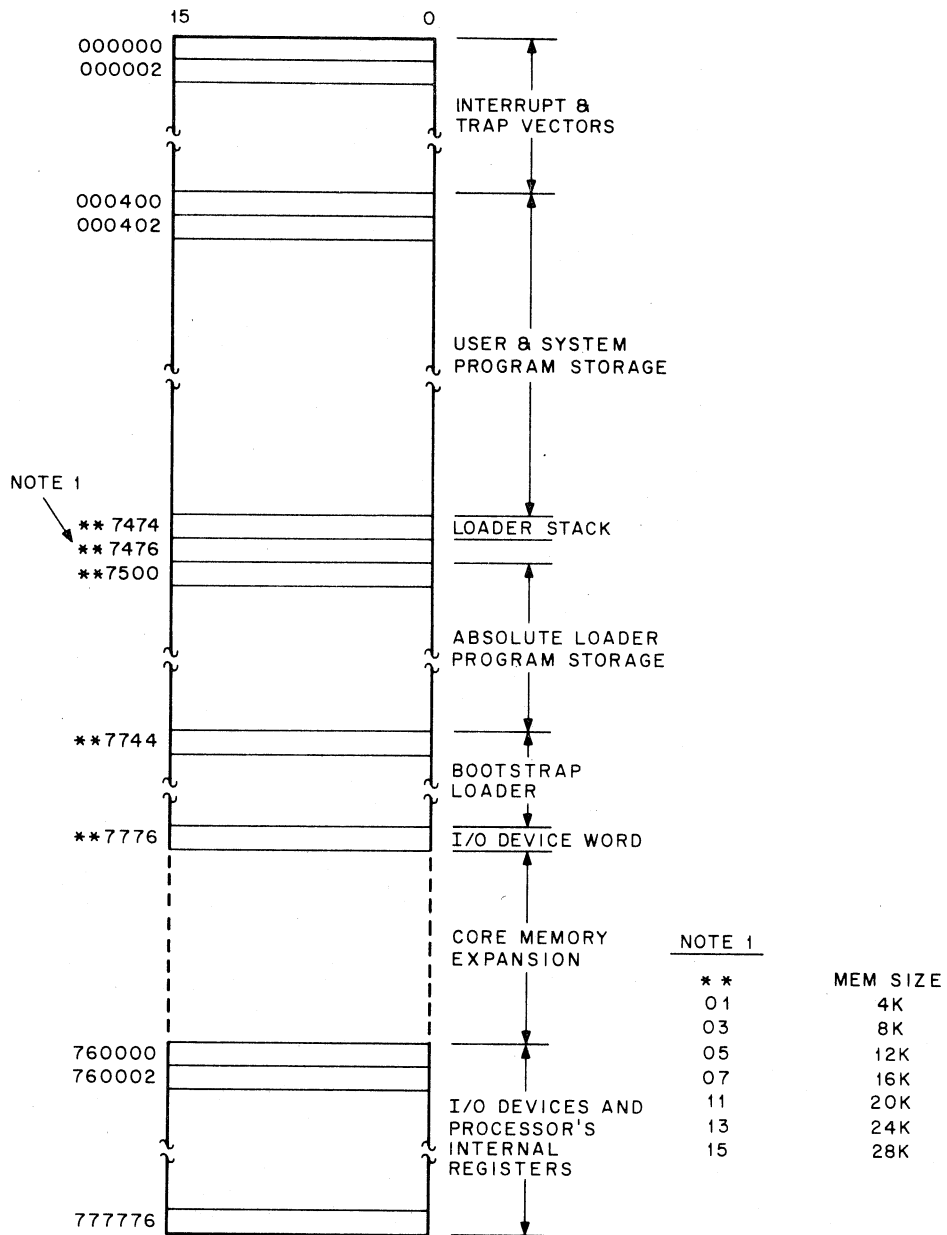

11-1492

PDP-11 Typical Core Memory Storage Map

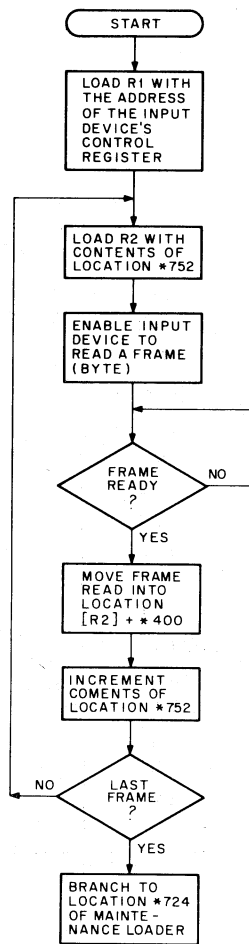

11-1493

Bootstrap Loader, Flow Chart

Bootstrap Loader Coding

Location	Octal	Symbolic
*744	016701	MOV *776, %1
746	26	
750	012702	MOV #352, %2
752	352	
754	005211	INC (1)
756	105711	TSTB (1)
760	100376	BPL -2
762	116162	MOVB 2(1), *400 (2)
764	2	
766	*400	
770	005267	INC *752
772	177756	
774	000765	BR -24
*776	177560	(TK)
	or, 177550	(PR)

* = 17	for	4K
37		8K
57		12K
77		16K
117		20K
137		24K
157	for	28K

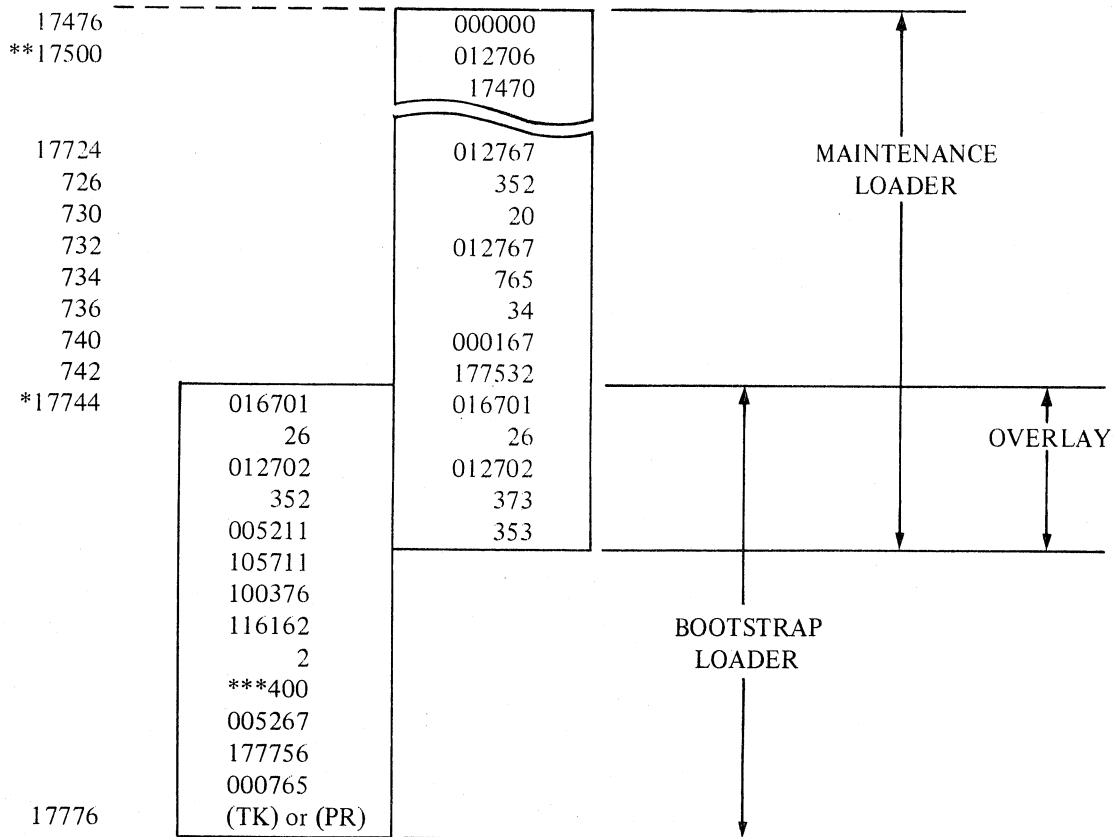

TK = 177560 Low-Speed Reader
 PR = 177550 High-Speed Reader

*Starting address of the Bootstrap Loader
 **Starting address of the Maintenance Loader

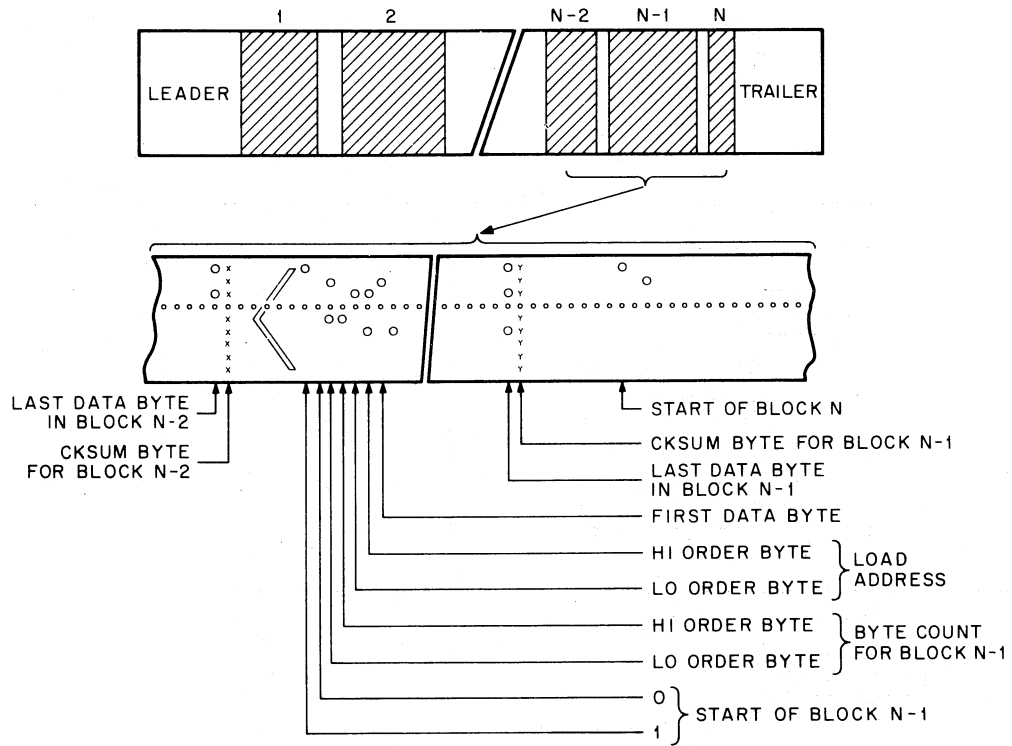

11-1461

Absolute Loader Tape Format

ADDRESSING MODES

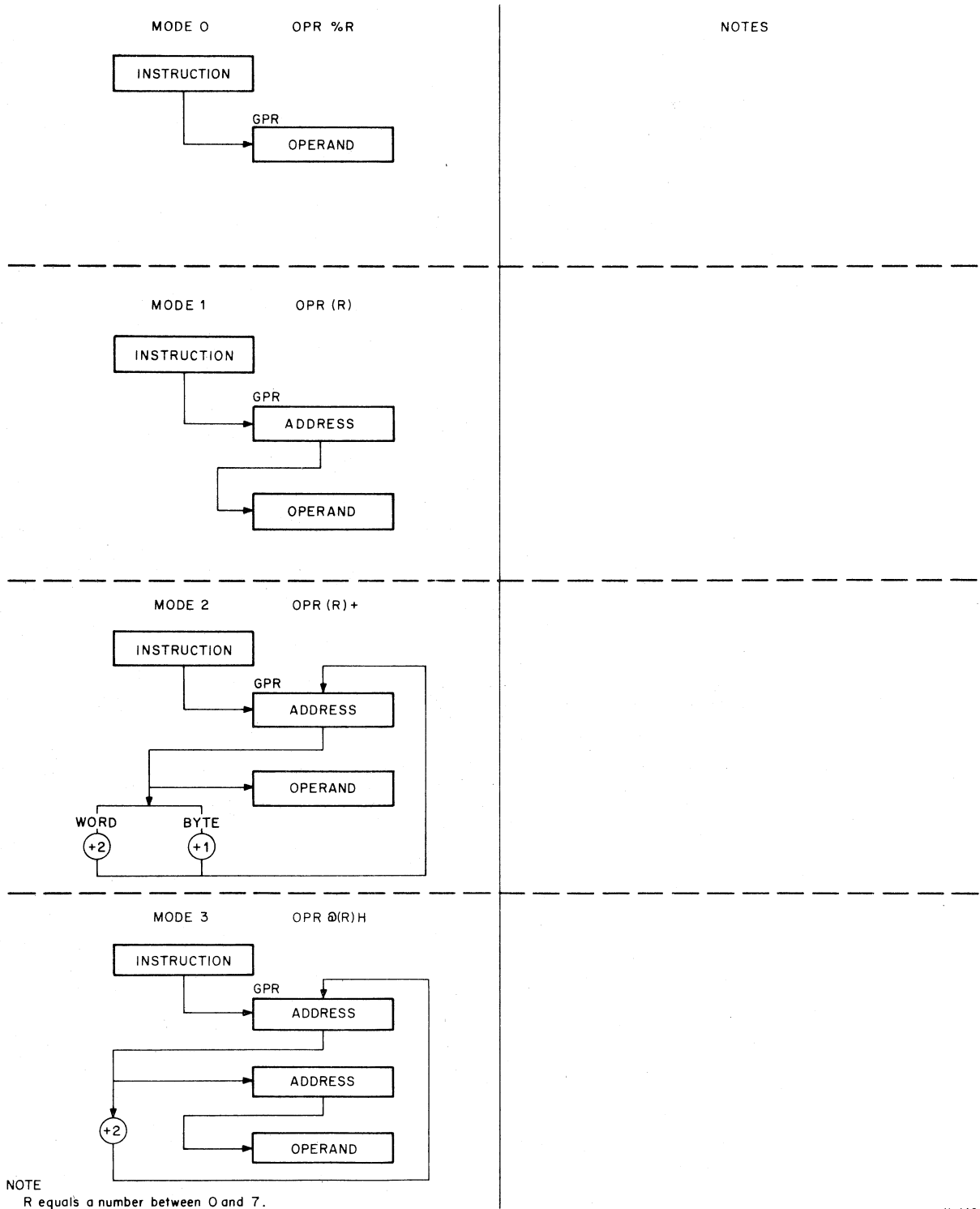

NOTE
R equals a number between 0 and 7.

11-1494

MODE 4 OPR-(R)

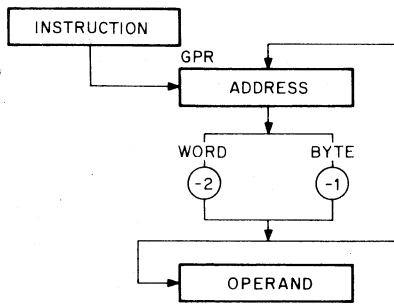

NOTES

MODE 5 OPR @-(R)

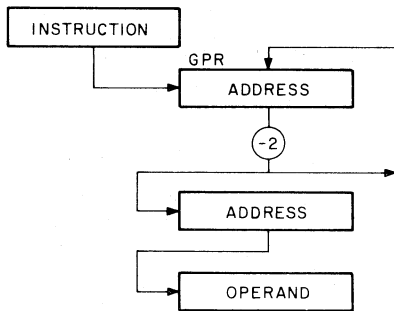

MODE 6 OPR±X(R)

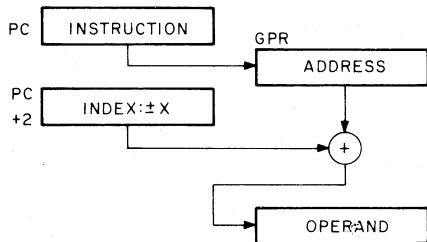

MODE 7 OPR @±X(R)

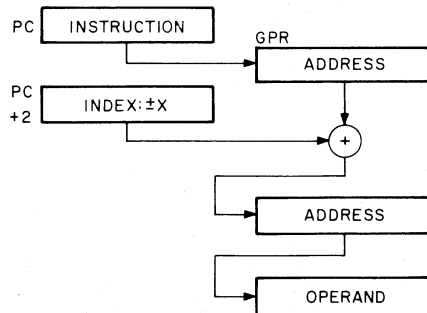

11-1495

PC REGISTER ADDRESSING

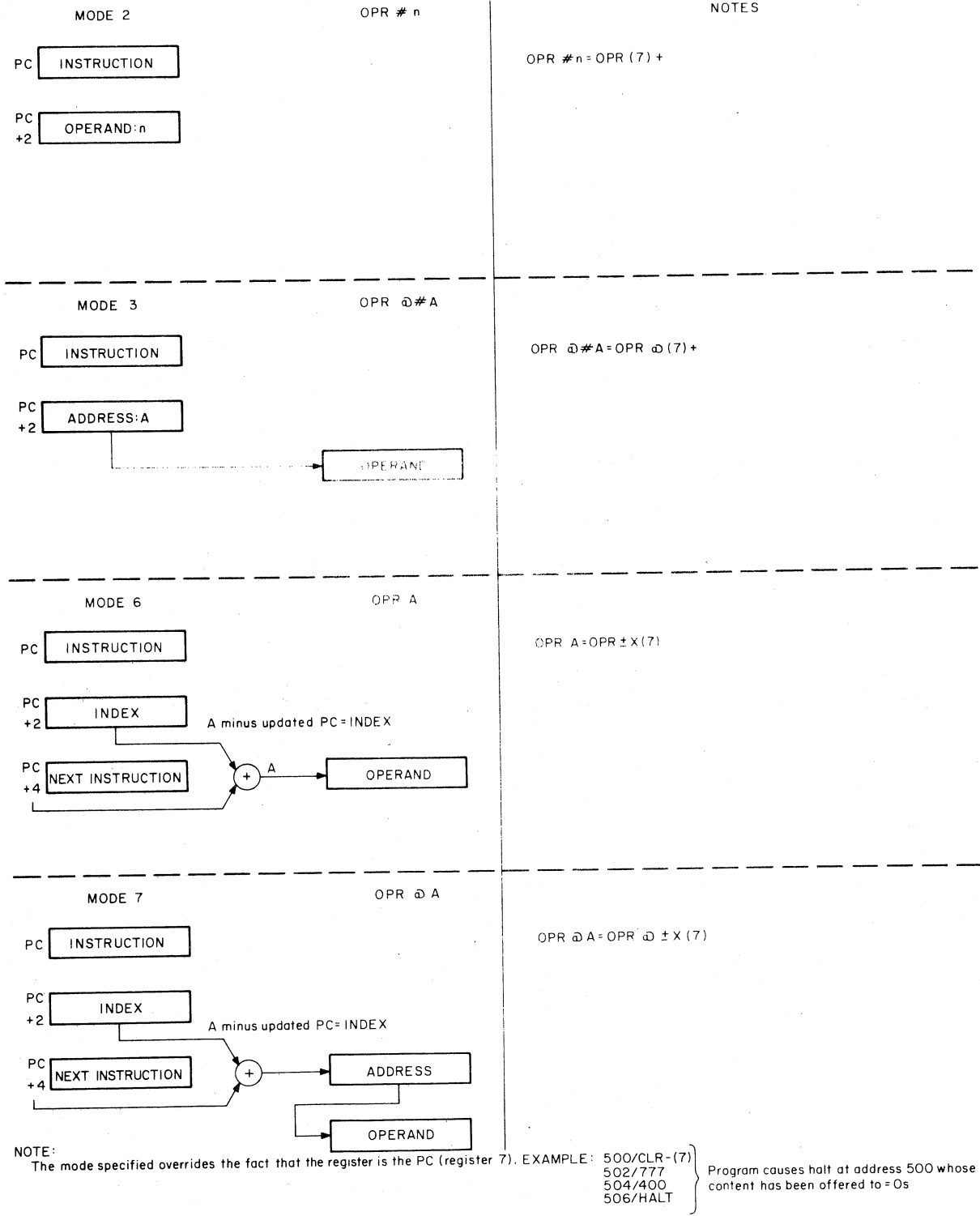

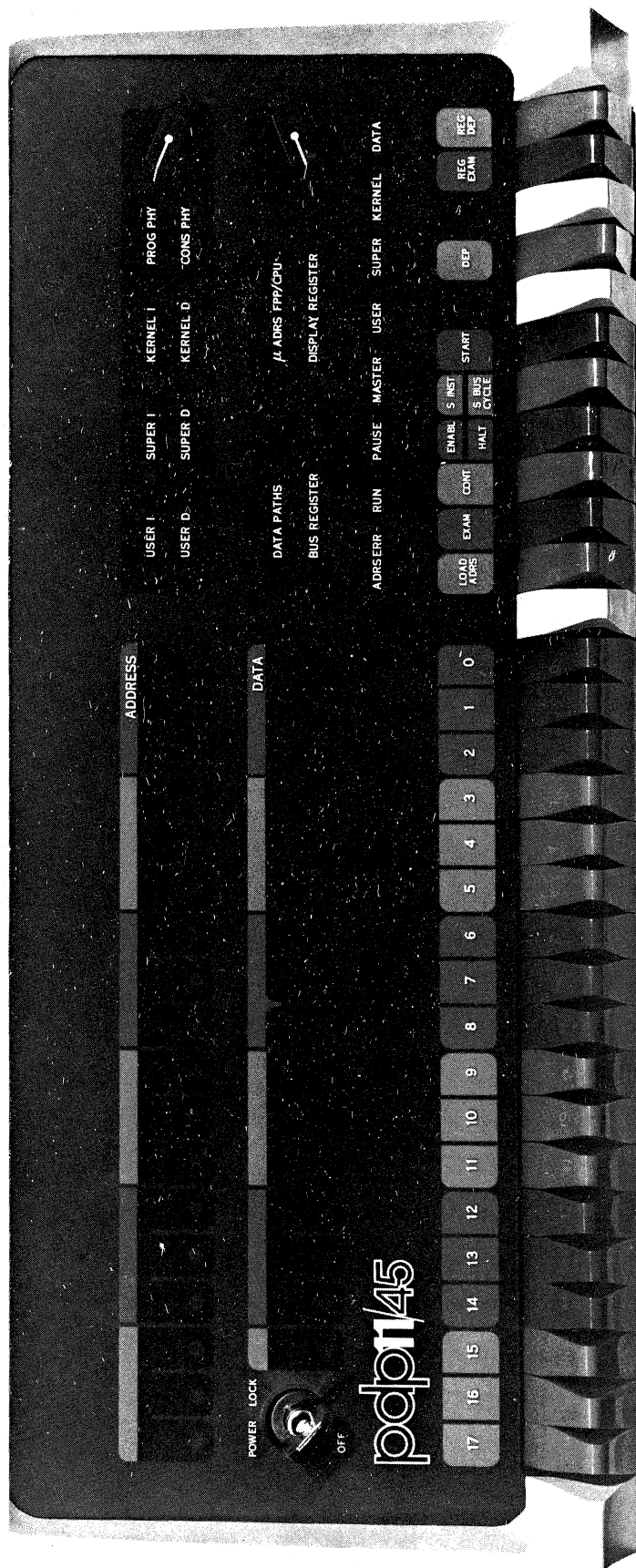

PDP-11/45 Operator's Console

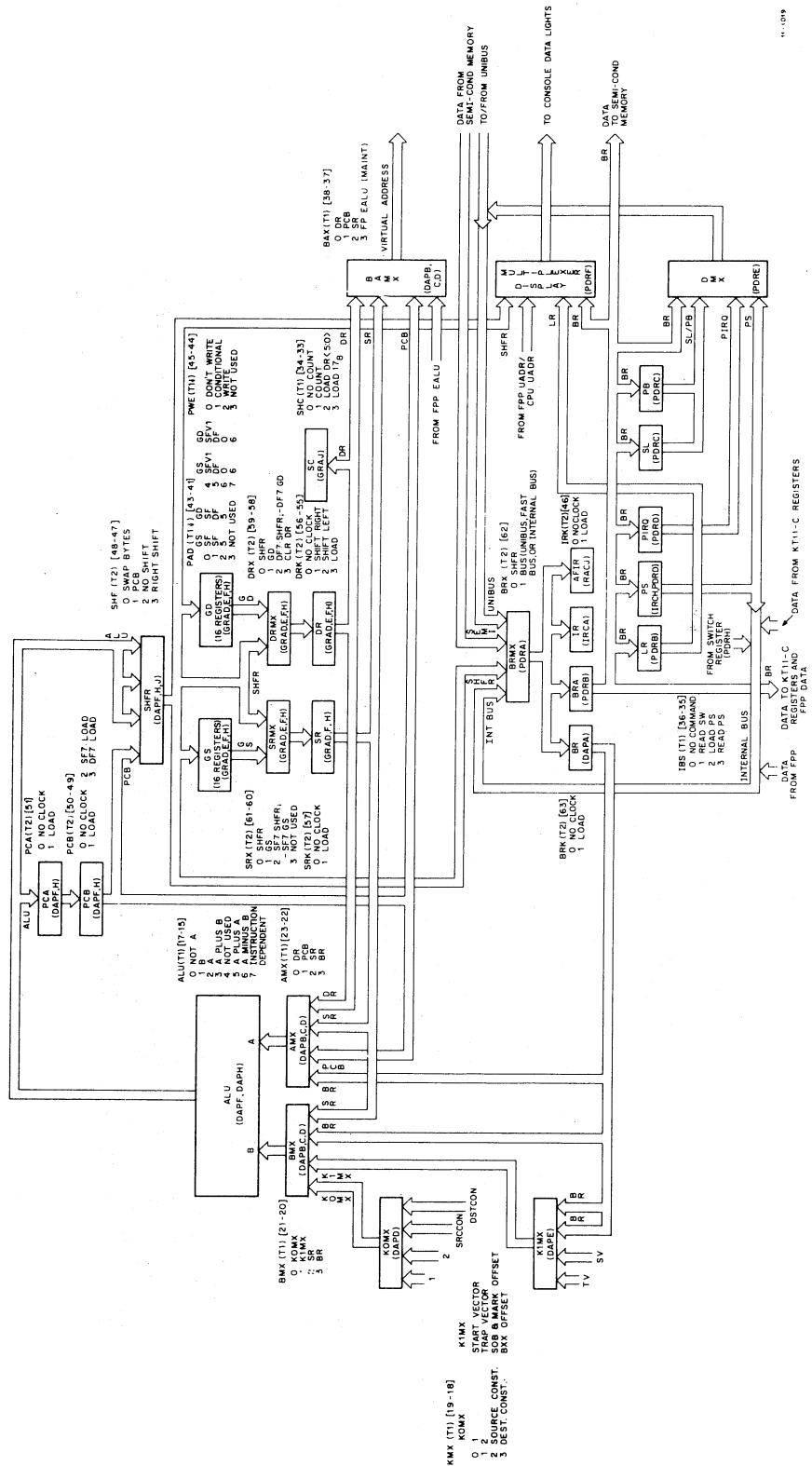

KB11-A Central Processor Data Paths, Block Diagram

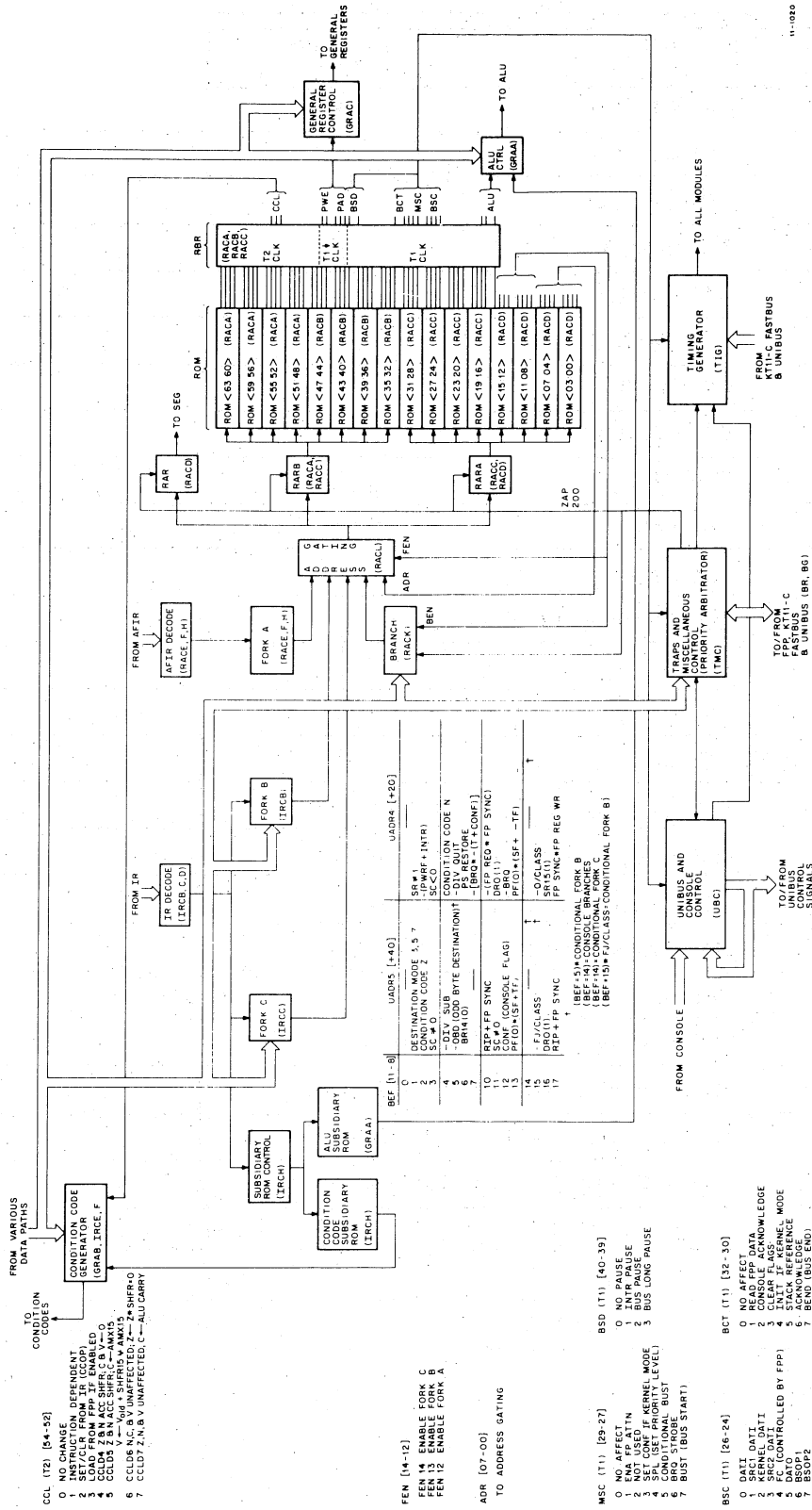

KB11-A Central Processor Control Section, Block Diagram

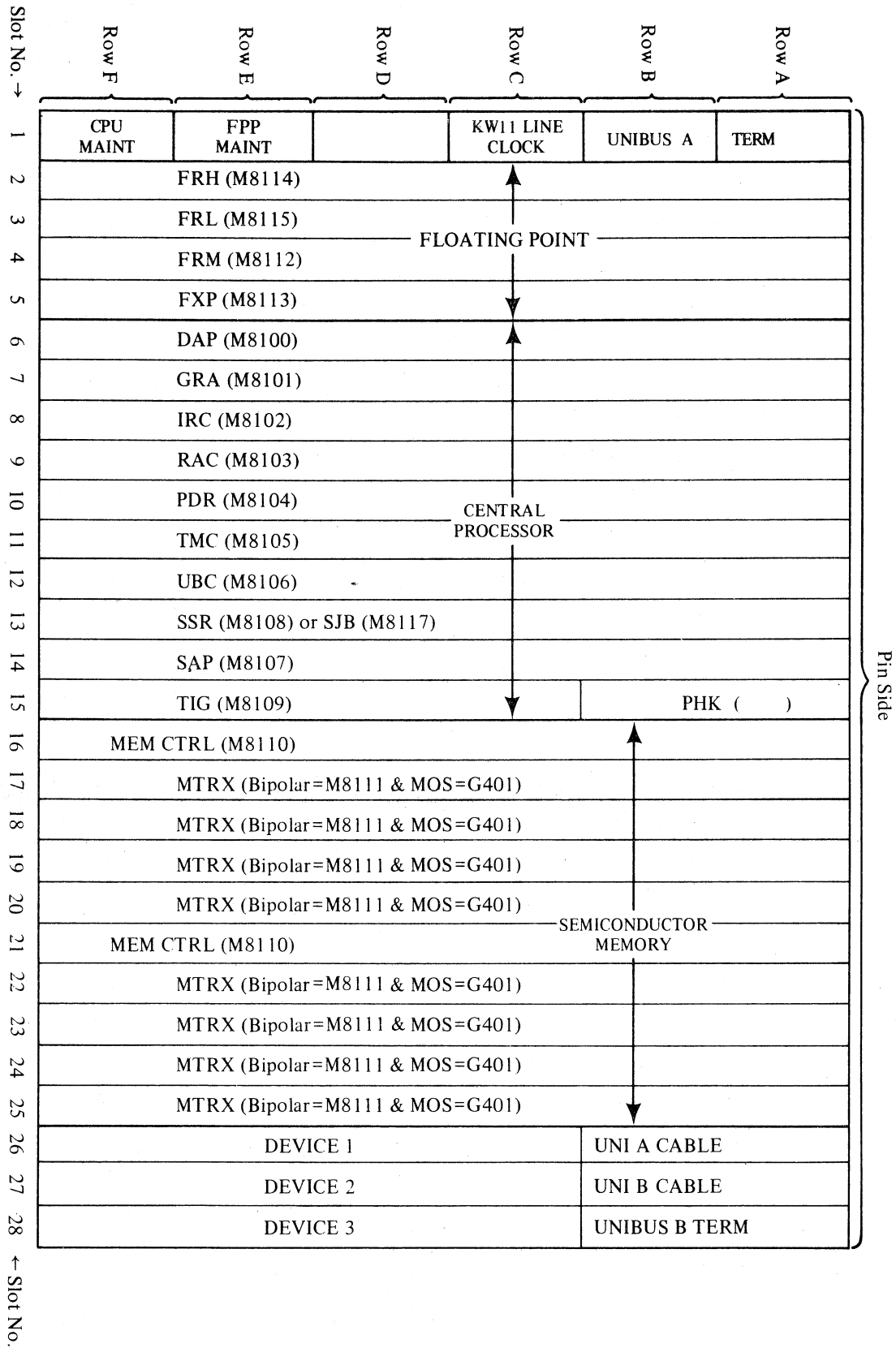

Module Layout

DEVICE REGISTER ADDRESSES

Device	CSR	DBR	Vector
Teletype Keyboard	777560	777562	60 BR4
Teletype Printer	777564	777566	64 BR4
Reader (PC11)	777550	777552	70 BR4
Punch (PC11)	777554	777556	74 BR4
Line Clock (KW11-L)	777546		100 BR6
Line Printer (LP11)	777514	777516	200 BR4
DECtape (TC11/TU56)	777340	777350	214 BR5
Control	777342		
Word Count	777344		
Current Address	777346		
DECdisk (RC11/RS64)	777444	777456	210 BR5
Look Ahead	777446		
Disk Address	777440		
Word Count	777442		
Current Address	777450		
Maintenance	777452		
Maintenance	777454		
DECdisk (RF11/RS11)	777460	777472	204 BR5
Word Count	777462		
Current Address	777464		
Disk Address	777466		
Disk Address Extended	777470		
Maintenance	777476		
DEC Disk Pack (RP11/RS03)	776714		254 BR5
Word Count	776716		
Current Address	776720		
Disk Cylinder Address	776722		
Disk Address	776724		
Device Status	776710		
Error Register	776712		
Maintenance Registers	776726		
	776730		
	776732		
Card Reader (CR11/CM11)	777160	777162 777164	
Magnetic Tape (TM11/TU10)	772522	772530	
Byte Count	772524		
Current Address	772526		
Status	772520		
Device Interface (DR11)	772414	772416	
Word Count	772410		
Current Address	772412		

ASCII 7-Bit Octal Code	Char	ASCII 7-Bit Octal Code	Char.	ASCII 7-Bit Octal Code	Char.	ASCII 7-Bit Octal Code	Char.
000	NUL	040	SP	100	(a)	140	'
001	SOH	041	!	101	A	141	a
002	STX	042	.	102	B	142	b
003	ETX	043	#	103	C	143	c
004	EOT	044	\$	104	D	144	d
005	ENQ	045	%	105	E	145	e
006	ACK	046	&	106	F	146	f
007	BEL	047	'	107	G	147	g
010	BS	050	(110	H	150	h
011	HT	051)	111	I	151	i
012	LF	052	.	112	J	152	j
013	VT	053	+	113	K	153	k
014	FF	054	,	114	L	154	l
015	CR	055	.	115	M	155	m
016	SO	056	.	116	N	156	n
017	SI	057	/	117	O	157	o
020	DLE	060	0	120	P	160	p
021	DC1	061	1	121	Q	161	q
022	DC2	062	2	122	R	162	r
023	DC3	063	3	123	S	163	s
024	DC4	064	4	124	T	164	t
025	NAK	065	5	125	U	165	u
026	SYN	066	6	126	V	166	v
027	ETB	067	7	127	W	167	w
030	CAN	070	8	130	X	170	x
031	EM	071	9	131	Y	171	y
032	SUB	072	:	132	Z	172	z
033	ESC	073	;	133	[173	(
034	FS	074	<	134	\	174	
035	GS	075	=	135]	175)
036	RS	076	>	136	↑	176	~
037	US	077	?	137	←	177	DEL

digital

DIGITAL EQUIPMENT CORPORATION, Maynard, Massachusetts, Telephone: (617) 897-5111 • ARIZONA, Phoenix • CALIFORNIA, Sunnyvale, Santa Ana, Los Angeles, San Diego and San Francisco (Mountain View) • COLORADO, Engelwood • CONNECTICUT, Meriden • DISTRICT OF COLUMBIA, Washington (Riverdale, Md.) • FLORIDA, Orlando • GEORGIA, Atlanta • ILLINOIS, Northbrook • INDIANA, Indianapolis • LOUISIANA, Metairie • MARYLAND, Riverdale • MASSACHUSETTS, Cambridge and Waltham • MICHIGAN, Ann Arbor and Detroit (Southfield) • MINNESOTA, Minneapolis • MISSOURI, Kansas City and Maryland Heights • NEW JERSEY, Fairfield, Metuchen and Princeton • NEW MEXICO, Albuquerque • NEW YORK, Huntington Station, Manhattan, New York, Syracuse and Rochester • NORTH CAROLINA, Durham/Chapel Hill • OHIO, Cleveland, Dayton and Euclid • OKLAHOMA, Tulsa • OREGON, Portland • PENNSYLVANIA, Bluebell, Paoli and Pittsburgh • TENNESSEE, Knoxville • TEXAS, Dallas and Houston • UTAH, Salt Lake City • WASHINGTON, Bellevue • WISCONSIN, Milwaukee • ARGENTINA, Buenos Aires • AUSTRALIA, Adelaide, Brisbane, Crows Nest, Melbourne, Norwood, Perth and Sydney • AUSTRIA, Vienna • BELGIUM, Brussels • BRAZIL, Rio de Janeiro, Sao Paulo and Porto Alegre • CANADA, Alberta, Vancouver, British Columbia; Hamilton, Mississauga and Ottawa, Ontario; and Quebec • CHILE, Santiago • DENMARK, Copenhagen and Hellerup • FINLAND, Helsinki • FRANCE, Grenoble and Rungis • GERMANY, Cologne, Hannover, Frankfurt, Munich and Stuttgart • INDIA, Bombay • ISRAEL, Tel Aviv • ITALY, Milano • JAPAN, Osaka and Tokyo • MEXICO, Mexico City • NETHERLANDS, The Hague • NEW ZEALAND, Auckland • NORWAY, Oslo • PHILIPPINES, Manila • PUERTO RICO, Miramar and Santurce • REPUBLIC OF CHINA, Taiwan • SCOTLAND, West Lothian • SPAIN, Barcelona and Madrid • SWEDEN, Solna and Stockholm • SWITZERLAND, Geneva and Zurich • UNITED KINGDOM, Birmingham, Bristol, Edinburgh, London, Manchester, Reading and Warwickshire • VENEZUELA, Caracas