

digital

RX02 Floppy Disk System User's Guide

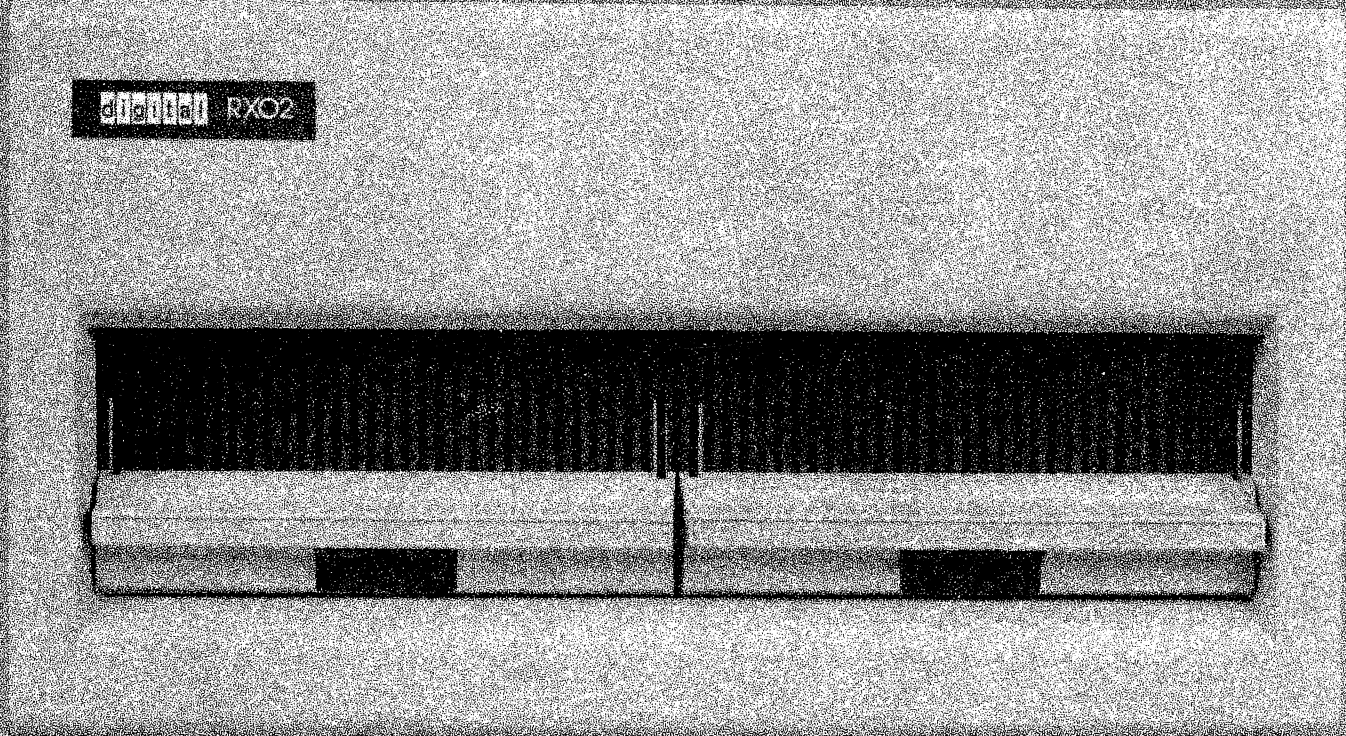

RX02 Floppy Disk System User's Guide

Copyright © 1978 by Digital Equipment Corporation

The material in this manual is for informational purposes and is subject to change without notice.

Digital Equipment Corporation assumes no responsibility for any errors which may appear in this manual.

Printed in U.S.A.

This document was set on DIGITAL's DECset-8000 computerized typesetting system.

The following are trademarks of Digital Equipment Corporation, Maynard, Massachusetts:

DIGITAL	DECsystem-10	MASSBUS
DEC	DECSYSTEM-20	OMNIBUS
PDP	DIBOL	OS/8
DECUS	EDUSYSTEM	RSTS
UNIBUS	VAX	RSX
	VMS	IAS

CONTENTS

	Page
PREFACE	
CHAPTER 1 GENERAL INFORMATION	
1.1 INTRODUCTION.....	1-1
1.2 GENERAL DESCRIPTION.....	1-2
1.2.1 Interface Modules	1-2
1.2.2 Microprogrammed Controller	1-5
1.2.3 Read/Write Electronics.....	1-5
1.2.4 Electromechanical Drive	1-5
1.2.5 Power Supply	1-6
1.3 OPTION DESCRIPTION.....	1-6
1.3.1 Operation For Single Density Recording Only (RX8E, RX11, RXV11).....	1-7
1.3.1.1 PDP-8 Operation.....	1-7
1.3.1.2 PDP-11 Operation.....	1-7
1.3.1.3 LSI-11 Operation	1-7
1.3.2 Operation For Single or Double Density Recording (RX28, RX211, RXV21).....	1-7
1.3.2.1 PDP-8 Operation.....	1-7
1.3.2.2 PDP-11 Operation.....	1-7
1.3.2.3 LSI-11 Operation	1-7
1.4 SPECIFICATIONS	1-7
1.5 SYSTEMS COMPATIBILITY	1-9
1.5.1 Media.....	1-9
1.5.2 Recording Scheme.....	1-10
1.5.2.1 Double Frequency (FM).....	1-10
1.5.2.2 Miller Code (MFM)	1-10
1.5.3 Logical Format.....	1-12
1.5.3.1 Header Field Description.....	1-12
1.5.3.2 Data Field Description	1-13
1.5.3.3 Track Usage	1-13
1.5.3.4 CRC Capability.....	1-13
CHAPTER 2 INSTALLATION	
2.1 SITE PREPARATION.....	2-1
2.1.1 Space.....	2-1
2.1.2 Cabling	2-2
2.1.3 AC Power.....	2-2
2.1.3.1 Power Requirements	2-2

CONTENTS (Cont)

	Page
2.1.3.2	Input Power Modification Requirements.....2-3
2.1.4	Fire and Safety Precautions2-3
2.2	CONFIGURATION GUIDELINES2-3
2.3	ENVIRONMENTAL CONSIDERATIONS.....2-4
2.3.1	General2-4
2.3.2	Temperature, Relative Humidity2-4
2.3.3	Heat Dissipation2-5
2.3.4	Radiated Emissions2-5
2.3.5	Cleanliness2-5
2.4	UNPACKING AND INSPECTION.....2-5
2.4.1	General2-5
2.4.2	Tools.....2-6
2.4.3	Unpacking2-6
2.4.3.1	Cabinet-Mounted.....2-6
2.4.3.2	Separate Container2-6
2.4.3.3	Inspection2-8
2.5	INSTALLATION.....2-8
2.5.1	PDP8-A Modification2-10
2.6	TESTING2-10
 CHAPTER 3 USER INFORMATION	
3.1	CUSTOMER RESPONSIBILITY.....3-1
3.2	CARE OF MEDIA.....3-1
3.2.1	Handling Practices and Precautions.....3-1
3.2.2	Diskette Storage3-2
3.2.2.1	Short Term (Available for Immediate Use)3-2
3.2.2.2	Long Term3-2
3.2.3	Shipping Diskettes.....3-2
3.3	OPERATING INSTRUCTIONS3-3
3.4	OPERATOR TROUBLESHOOTING3-3
 CHAPTER 4 PROGRAMMING	
4.1	RX8E AND RX28 Programming Information.....4-1
4.1.1	Device Codes.....4-1
4.1.2	Instruction Set.....4-2
4.1.2.1	RX8E Load Command (LCD)4-2
4.1.2.2	RX28 Load Command4-3
4.1.2.3	Transfer Data Register (XDR)4-3
4.1.2.4	STR4-3
4.1.2.5	SER4-4
4.1.2.6	SDN.....4-4
4.1.2.7	INTR.....4-4
4.1.2.8	INIT4-4

CONTENTS (Cont)

	Page	
4.1.3	Register Description.....	4-4
4.1.3.1	Command Register.....	4-4
4.1.3.2	Error Code Register.....	4-5
4.1.3.3	RX2TA – RX Track Address.....	4-6
4.1.3.4	RX2SA – RX Sector Address.....	4-6
4.1.3.5	RX2DB – RX Data Buffer.....	4-6
4.1.3.6	RX8E – RX Error and Status.....	4-6
4.1.3.7	RX28 – RX Error and Status.....	4-7
4.1.4	Function Code Description.....	4-8
4.1.4.1	Fill Buffer (000).....	4-9
4.1.4.2	Empty Buffer (001).....	4-9
4.1.4.3	Write Sector (010).....	4-9
4.1.4.4	Read Sector (011).....	4-10
4.1.4.5	Set Media Density (100) for RX28 only.....	4-10
4.1.4.6	Maintenance Read Status (101) for RX28 only.....	4-10
4.1.4.7	Read Status (101) for RX8E only.....	4-10
4.1.4.8	Write Deleted Data Sector (110).....	4-11
4.1.4.9	Read Error Code Function (111).....	4-11
4.1.4.10	Power Fail.....	4-11
4.1.5	Error Recovery.....	4-11
4.1.5.1	RX8E.....	4-11
4.1.5.2	RX28.....	4-12
4.1.6	RX8E Programming Examples.....	4-13
4.1.6.1	Write/Write Deleted Data/Read Functions.....	4-13
4.1.6.2	Empty Buffer Function.....	4-13
4.1.6.3	Fill Buffer Function.....	4-13
4.1.7	RX28 Programming Examples.....	4-17
4.1.8	Restrictions and Programming Pitfalls.....	4-22
4.2	RX11 AND RXV11 PROGRAMMING INFORMATION	4-23
4.2.1	Register and Vector Addresses.....	4-23
4.2.2	Register Description.....	4-24
4.2.2.1	RXCS – Command and Status (177170).....	4-24
4.2.2.2	RXDB – Data Buffer Register (177172).....	4-25
4.2.2.3	RXTA – RX Track Address.....	4-25
4.2.2.4	RXSA – RX Sector Address.....	4-25
4.2.2.5	RXDB – RX Data Buffer.....	4-25
4.2.2.6	RXES – RX Error and Status.....	4-26
4.2.3	Function Codes.....	4-27
4.2.3.1	Fill Buffer (000).....	4-27
4.2.3.2	Empty Buffer (001).....	4-27
4.2.3.3	Write Sector (010).....	4-28
4.2.3.4	Read Sector (011).....	4-28
4.2.3.5	Read Status (101).....	4-29
4.2.3.6	Write Sector with Deleted Data (110).....	4-29
4.2.3.7	Read Error Code Function (111).....	4-29

CONTENTS (Cont)

		Page
4.2.3.8	Power Fail	4-29
4.2.4	Programming Examples	4-30
4.2.4.1	Read Data/Write Data	4-30
4.2.4.2	Empty Buffer Function	4-30
4.2.4.3	Fill Buffer Function	4-30
4.2.5	Restrictions and Programming Pitfalls	4-30
4.2.6	Error Recovery	4-34
4.3	RX211 AND RXV21 PROGRAMMING INFORMATION	4-34
4.3.1	Register and Vector Addresses	4-35
4.3.2	Register Description	4-35
4.3.2.1	RX2CS – Command and Status (177170)	4-35
4.3.2.2	RX2DB – Data Buffer Register (177172)	4-36
4.3.2.3	RX2TA – RX Track Address	4-37
4.3.2.4	RX2SA – RX Sector Address	4-37
4.3.2.5	RX2WC – RX Word Count Register	4-37
4.3.2.6	RX2BA – RX Bus Address Register	4-37
4.3.2.7	RX2DB – RX Data Buffer	4-37
4.3.2.8	RX2ES – RX Error and Status	4-38
4.3.3	Function Codes	4-39
4.3.3.1	Fill Buffer (000)	4-39
4.3.3.2	Empty Buffer (001)	4-39
4.3.3.3	Write Sector (010)	4-39
4.3.3.4	Read Sector (011)	4-40
4.3.3.5	Set Media Density (100)	4-41
4.3.3.6	Maintenance Read Status (101)	4-41
4.3.3.7	Write Sector with Deleted Data (110)	4-41
4.3.3.8	Read Error Code (111)	4-41
4.3.3.9	RX02 Power Fail	4-42
4.3.4	Error Recovery	4-43
4.3.5	RX211/RXV21 Programming Examples	4-43
4.3.5.1	Write/Fill Buffer	4-43
4.3.5.2	Read/Empty Buffer	4-45

FIGURES

Figure No.	Title	Page
1-1	Floppy Disk Configuration	1-3
1-2	Front View of the Floppy Disk System	1-3
1-3	Interface Modules	1-4
1-4	Top View of RX02	1-5

FIGURES (Cont)

Figure No.	Title	Page
1-5	Underside View of Drive	1-6
1-6	Diskette Media.....	1-9
1-7	Flux Reversal Patterns for FM	1-10
1-8	FM versus MFM Encoding	1-11
1-9	Track Format (Each Track).....	1-12
1-10	Sector Format (Each Sector).....	1-12
2-1	RX02 Outline Dimensions.....	2-1
2-2	Cabinet Layout Dimensions	2-2
2-3	RX02 Rear View	2-3
2-4	RX02 Unpacking	2-7
2-5	RX02 Cabinet Mounting Information	2-7
2-6	KM8-A Modification	2-10
4-1	LCD Word Format (RX8E).....	4-2
4-2	Command Word Format (RX28)	4-3
4-3	Command Register Format (RX8E).....	4-4
4-4	Command Register Format (RX28)	4-4
4-5	Error Code Register Format (RX8E/RX28A).....	4-5
4-6	RX2TA Format (RX8E/RX28A)	4-6
4-7	RX2SA Format (RX8E/RX28).....	4-6
4-8	RX2DB Format (RX8E/RX28).....	4-7
4-9	RXES Format (RX8E).....	4-7
4-10	RX2ES Format (RX28).....	4-8
4-11	RX8E Write/Write Deleted Data/Read Example.....	4-15
4-12	RX8E Empty Buffer Example.....	4-17
4-13	RX8E Fill Buffer Example.....	4-18
4-14	RX28 Write/Write Deleted Data/Read Example	4-19
4-15	RX28 Fill Buffer Example	4-21
4-16	RX28 Empty Buffer Example	4-22
4-17	RXCS Format (RX11/RXV11).....	4-25
4-18	RXTA Format (RX11/RXV11).....	4-26
4-19	RXSA Format (RX11/RXV11).....	4-26
4-20	RXDB Format (RX11/RXV11).....	4-26
4-21	RXES Format (RX11/RXV11).....	4-27
4-22	RX11/RXV11 Write/Write Deleted Data/Read Example.....	4-32
4-23	RX11/RXV11 Empty Buffer Example.....	4-33
4-24	RX11/RXV11 Fill Buffer Example.....	4-34
4-25	RX2CS Format (RX211/RXV21)	4-36
4-26	RX2TA Format (RX211/RXV21).....	4-38
4-27	RX2SA Format (RX211/RXV21).....	4-38
4-28	RX2WC Format (RX211/RXV21).....	4-38
4-29	RX2BA and RX2DB Format (RX211/RXV21)	4-38
4-30	RX2ES Format (RX211/RXV21)	4-39
4-31	RX211/RXV21 Write/Fill Buffer Example	4-45
4-32	RX211/RXV21 Read/Empty Buffer Example.....	4-46

TABLES

Table No.	Title	Page
1-1	Data Address Mark Code.....	1-13
2-1	RX02 Configurations.....	2-4
2-2	Controller Configuration Switch Positions	2-4
2-3	Interface Code/Jumper Configuration	2-9
3-1	Operator Troubleshooting Guide	3-3
4-1	Device Code Switch Selection.....	4-2

PREFACE

This manual is intended to provide the user with sufficient information to correctly set up and operate the RX02 Floppy Disk System in any of the various configurations that are available for use with the PDP-8, PDP-11, or LSI-11 computers. The manual presents general, installation, user, and programming information for the RX02 Floppy Disk System and the interface options associated with the PDP-8, PDP-11, and LSI-11 computer systems.

CHAPTER 1 GENERAL INFORMATION

1.1 INTRODUCTION

The RX02 is a low cost, random access mass memory device that stores data in fixed length blocks on flexible diskettes with preformatted industry standard headers. The RX02 interfaces with either a PDP-8, a PDP-11, or an LSI-11 system. Various interface modules are selected according to the computer being used and either single or double density recording. The various configurations are:

Designation	Computer	Interface Module	Recording Density
RX8E	PDP-8	M8357	Single
RX28	PDP-8	M8357	Single or Double
RX11	PDP-11	M7846	Single
RX211	PDP-11	M8256	Single or Double
RXV11	LSI-11	M7946	Single
RXV21	LSI-11	M8029	Single or Double

NOTE

The single density recording configurations RX8E, RX11, and RXV11 are compatible with the RX01 Floppy Disk System when the M7744 controller module has been switched to be compatible with these configurations. (See Table 2-2.)

The RX02 consists of two flexible disk drives, a single read/write electronics module, a micro-programmed controller module, and a power supply, enclosed in a rack-mountable, 10-1/2 inch, self-cooled chassis. A cable is included for connection to either a PDP-8 interface module, a PDP-11 interface module, or an LSI-11 interface module. The amount of data that can be stored on the RX02 varies according to the configuration. The recording density can be different for each drive. For each drive system using double density recording, up to 512K 8-bit bytes of data (PDP-8, PDP-11, LSI-11) or 256K 12-bit words (PDP-8) can be stored and retrieved. For each drive system using single density recording, up to 256K 8-bit bytes of data or 128K 12-bit words (PDP-8) can be stored and retrieved. The RX02 interfaces with IBM-compatible devices when single density data recording is used.

For single or double density recording, the RX02 is used with either an M8357 interface module (PDP-8), an M8256 interface module (PDP-11), or an M8029 interface module (LSI-11). The interface modules convert the RX02 I/O bus to the bus structure of the computer being used. Each module controls the interrupts to the CPU initiated by the RX02 and handles the data interchange between the RX02 and the host computer. Each interface module is powered by the host processor.

In addition, the RX02 is used for single density recording when it is configured to be compatible with the RX01. The interface module used is either an M8357 (PDP-8), an M7846 (PDP-11), or an M7946 (LSI-11).

To record or retrieve data the RX02 performs implied seeks. Given an absolute sector address, the RX02 locates the desired sector and performs the indicated function, including automatic head position verification and hardware calculation and verification of the cyclic redundancy check (CRC) character. The CRC character that is read and generated is compatible with IBM 3740 equipment.

1.2 GENERAL DESCRIPTION

An RX02 Floppy Disk System consists of the following components:

- M7744 Controller Module
- M7745 Read/Write Electronics Module
- H771-A, -C, or -D Power Supply
- RX02-CA Floppy Disk Drive (60 Hz max of 2)
- RX02-CC Floppy Disk Drive (50 Hz max of 2)

One interface module is used:

- | | |
|--------------------------------|-------------------------|
| M8357 (PDP-8, Programmed I/O) | |
| M7846 (PDP-11, Programmed I/O) | M8256 (PDP-11 with DMA) |
| M7946 (LSI-11, Programmed I/O) | M8029 (LSI-11 with DMA) |

All components except the interface modules are housed in a 10-1/2 inch rack-mountable box. The power supply, M7744 module, and M7745 module are mounted above the drives. Interconnection from the RX02 to the interface is with a 40-conductor BC05L-15 cable of standard length (15 ft). Figure 1-1 is a configuration drawing of the system: part A shows the configuration for a bus interface with DMA; part B shows the configuration for all Omnibus interfaces (programmed I/O); part C shows the configuration for a bus interface (programmed I/O) that is RX01 compatible. Figure 1-2 is a front view of a dual drive system.

1.2.1 Interface Modules

The interface modules plug into a slot on the bus for PDP-8, PDP-11, and LSI-11 computers. Figure 1-3 shows the outline of the various modules and areas of interest on each module.

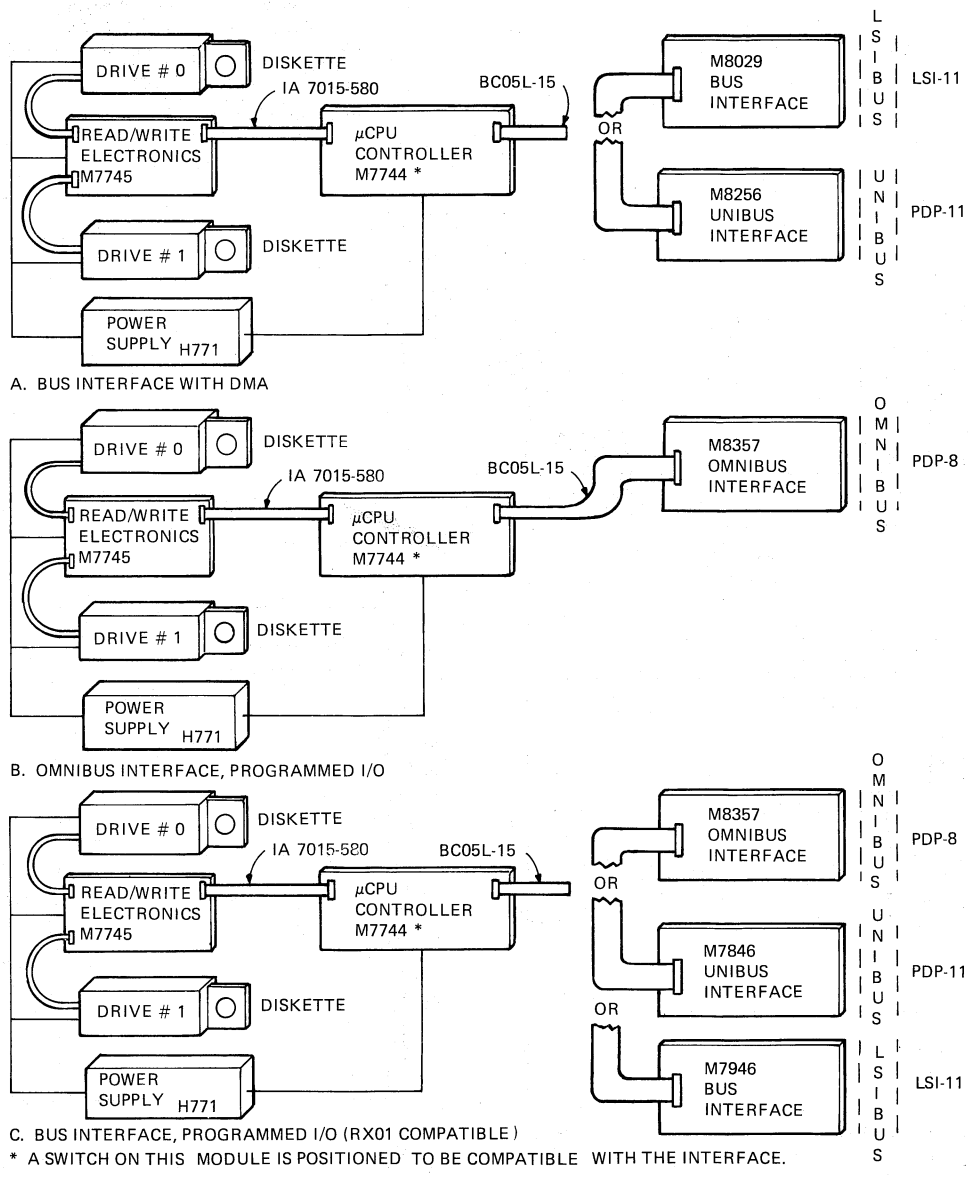

MA-1857

Figure 1-1 Floppy Disk Configuration

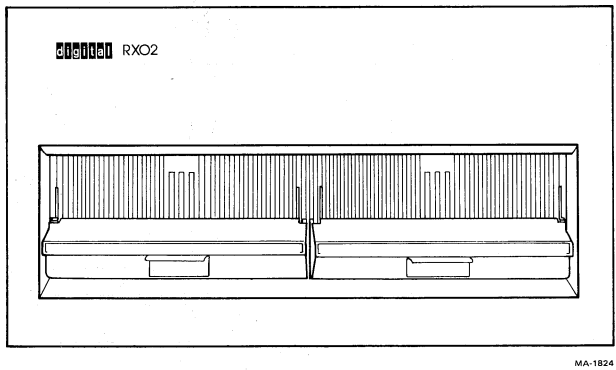

MA-1824

Figure 1-2 Front View of the Floppy Disk System

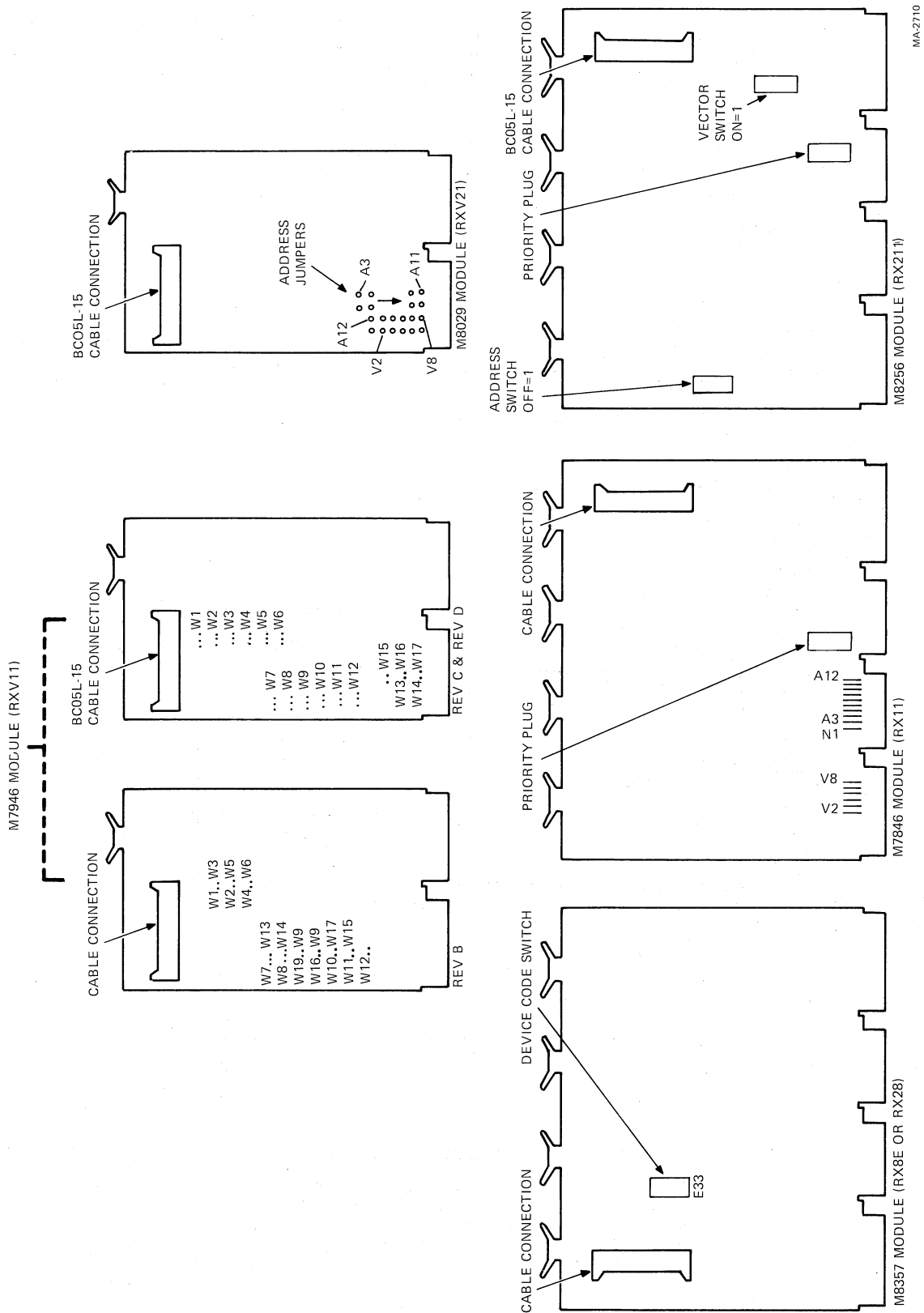

Figure 1-3 Interface Modules

1.2.2 Microprogrammed Controller

The M7744 microprogrammed controller module is located in the RX02 cabinet as shown in Figure 1-4. The M7744 is hinged on the left side and lifts up for access to the M7745 read/write electronics module.

1.2.3 Read/Write Electronics

The M7745 read/write electronics module is located in the RX02 cabinet as shown in Figure 1-4.

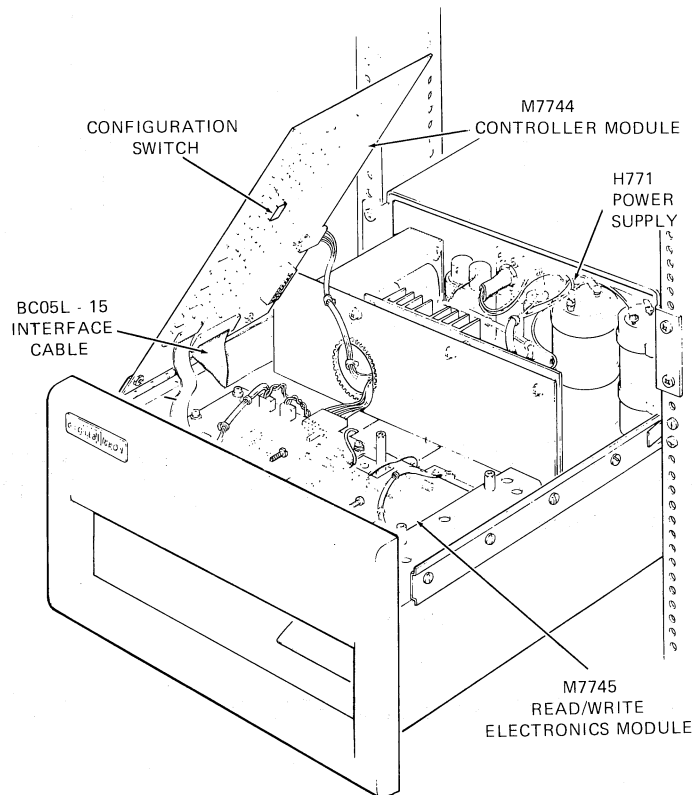

MA-1751

Figure 1-4 Top View of RX02

1.2.4 Electromechanical Drive

A maximum of two drives can be attached to the read/write electronics. The electromechanical drives are mounted side by side under the read/write electronics board (M7745). Figure 1-5 is an underside view of the drive showing the drive motor connected to the spindle by a belt. (This belt and the drive pulley are different on the 50 Hz and 60 Hz units; see Paragraph 2.1.3.2 for complete input power modification requirements.)

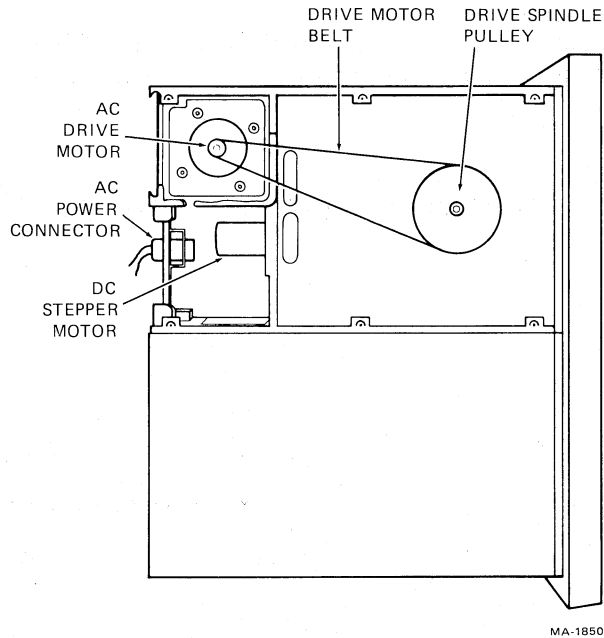

Figure 1-5 Underside View of Drive

1.2.5 Power Supply

The H771 power supply is mounted at the rear of the RX02 cabinet as shown in Figure 1-4. The H771-A is rated at 60 Hz \pm 1/2 Hz over a voltage range of 90–128 Vac. The H771-C and -D are rated at 50 Hz + 1/2 Hz over four voltage ranges:

90–120 Vac	}	3.5 A circuit breaker; H771-C
100–128 Vac		
184–240 Vac		
200–256 Vac	}	1.75 A circuit breaker; H771-D

Two configuration plugs are provided to adapt the H771-C or -D to each voltage range. This is not applicable to the H771-A.

1.3 OPTION DESCRIPTION

The optional interface modules that are used to interface the RX02 with a PDP-8, PDP-11, and LSI-11 are listed in Paragraphs 1.1 and 1.2. (Each module is powered by the host processor.) The module selected is determined by the computer being used and whether the data interchange is between either IBM system 3740 compatible devices or DIGITAL system double density devices. Also, when an M7744 controller module's configuration switch is set to be compatible, the RX02 can operate as an RX01. The RX02 interfaces with IBM compatible devices when single density data recording is used. The RX02 interfaces with DIGITAL system double density recording devices when the controller module configuration switch is positioned to be compatible with RX28, RX211, and RXV21 configurations.

1.3.1 Operation For Single Density Recording Only (RX8E, RX11, RXV11)

1.3.1.1 PDP-8 Operation – The RX02 connects to the M8357 Omnibus interface module. This module converts the RX02 I/O bus to PDP-8 family Omnibus structure. It controls interrupts to the CPU initiated by the RX02, controls data interchange between the RX02 and the host CPU by programmed I/O, and handles input/output transfers used for maintenance status conditions.

1.3.1.2 PDP-11 Operation – The RX02 connects to the M7846 Unibus interface module. This module converts the RX02 I/O bus to PDP-11 Unibus structure. It controls interrupts to the CPU initiated by the RX02, decodes Unibus addresses for register selection, and handles data interchange between the RX02 and the host CPU main memory by programmed I/O.

1.3.1.3 LSI-11 Operation – The RX02 connects to the M7946 LSI-11 bus interface module. This module converts the RX02 I/O bus to the LSI-11 bus structure. It controls interrupts to the CPU initiated by the RX02, decodes LSI-11 bus addresses for register selection, and transfers data between the RX02 and the host CPU main memory by programmed I/O.

1.3.2 Operation For Single or Double Density Recording (RX28, RX211, RXV21)

1.3.2.1 PDP-8 Operation – The RX02 connects to the M8357 Omnibus interface module. This module converts the RX02 I/O bus to PDP-8 family Omnibus structure. It controls interrupts to the CPU initiated by the RX02, controls transfer of data between the RX02 and host CPU by programmed I/O, and handles input/output transfer used to test status conditions.

1.3.2.2 PDP-11 Operation – The RX02 connects to the M8256 Unibus interface module. This module converts the RX02 I/O bus to PDP-11 Unibus structure. It controls interrupts to the CPU initiated by the RX02, decodes Unibus addresses for register selection, and initiates NPR requests to transfer data between the RX02 and the host CPU main memory.

1.3.2.3 LSI-11 Operation – The RX02 connects to the M8029 LSI-11 bus interface module. This module converts the RX02 I/O bus to the LSI-11 bus structure. It controls interrupts to the CPU initiated by the RX02, decodes LSI-11 bus addresses for register selection, and initiates NPR requests to transfer data between the RX02 and the host CPU main memory.

1.4 SPECIFICATIONS

System Reliability

Minimum number of revolutions per track	3 million/media (head loaded)
Seek error rate	1 in 10^6 seeks
Soft data error rate	1 in 10^9 bits read or written
Hard data error rate	1 in 10^{12} bits read or written

NOTE

The above error rates only apply to DEC approved media that is properly cared for. Seek error and soft data errors are usually attributable to random effects in the head/media interface, such as electrical noise, dirt, or dust. Both are called "soft" errors if the error is recoverable in 10 additional tries or less. "Hard" errors cannot be recovered. Seek error retries should be preceded by a recalibrate.

Drive Performance

Capacity	Recording	8-bit bytes	12-bit words
Per diskette	FM	256,256	128,128
	MFM	512,512	256,256
Per track	FM	3,328	1,664
	MFM	6,656	3,328
Per sector	FM	128	64
	MFM	256	128

Data transfer rate

Diskette to controller buffer	4 μ s/data bit (FM)
	2 μ s/data bit (MFM)
Buffer to CPU interface	1.2 μ s/bit

NOTE

PDP-8 interface can operate in 8- or 12-bit modes under software control.

Track-to-track move	6 ms/track maximum
Head settle time	25 ms maximum
Rotational speed	360 rpm \pm 2.5%; 166 ms/rev nominal
Recording surfaces per disk	1
Tracks per disk	77 (0-76) or (0-114 _g)
Sectors per track	26 (1-26) or (0-32 _g)
Recording technique	Double frequency (FM) or modified MFM
Bit density maximum on inner track	3200 bpi (FM) or modified (MFM)
Track density	48 tracks/inch
Average access	262 ms, computed as follows:
	$\underbrace{77 \text{ tks}/3 \times 6 \text{ ms}}_{\text{Seek}} \quad \underbrace{+ 25 \text{ ms}}_{\text{Settle}} \quad \underbrace{+ 166 \text{ ms}/2 = 262 \text{ ms}}_{\text{Rotate}}$

Environmental Characteristics

Temperature

RX02, operating	15° to 32° C (59° to 90° F) ambient; maximum temperature gradient = 11° C/hr (20° F/hr)
RX02, nonoperating	-35° to +60° C (-30° to +140° F)
Media, nonoperating	-35° to +52° C (-30° to +125° F)

NOTE

Media temperature must be within operating temperature range before use.

Heat Dissipation (RX02 System) Less than 225 Btu/hr

Relative humidity

RX02, operating	25° C (77° F) maximum wet bulb 2° C (36° F) minimum dew point 20% to 80% relative humidity
-----------------	--

RX02, nonoperating
Media, nonoperating
Magnetic field

5% to 98% relative humidity (no condensation)
10% to 80% relative humidity
Media exposed to a magnetic field strength of 50 oersteds or greater may lose data.

Interface modules

Operating temperature 5° to 50° C (41° to 122° F)
Relative humidity 10% to 90%
Maximum wet bulb 32° C (90° F)
Minimum dew point 2° C (36° F)

Electrical

Power consumption
RX02 5 A at +5 Vdc, 25 W; 0.14 A at -5 Vdc, 0.7 W; 1.3 A at +24 Vdc, 31 W
PDP-11 interface (M7846, M8256) 1.8 A at 5 Vdc
PDP-8 interface (M8357) 1.5 A at 5 Vdc
LSI-11 interface (M7946, M8029) 1.8 A at 5 Vdc
AC power 4 A at 115 Vac
2 A at 230 Vac

1.5 SYSTEMS COMPATIBILITY

This section describes the physical, electrical, and logical aspects of compatibility for data interchange with IBM system 3740 devices and for data interchange with double density devices.

1.5.1 Media

The media used on the RX02 Floppy Disk system is compatible with the IBM 3740 family of equipment and is shown in Figure 1-6. The "diskette" media was designed by applying tape technology to disk architecture, resulting in a flexible oxide-on-mylar surface. The diskette is encased in a plastic envelope with a hole for the read/write head, a hole for the drive spindle hub, and a hole for the hard index mark. The envelope is lined with a fiber material that cleans the diskette surface. The media is supplied to the customer preformatted and pretested.

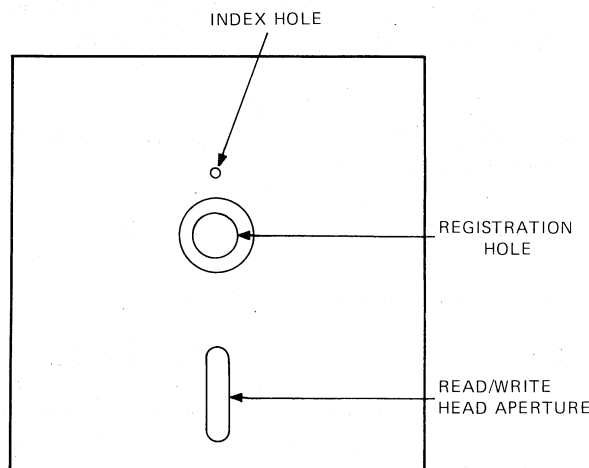

MA-1750

Figure 1-6 Diskette Media

1.5.2 Recording Scheme

There are two recording schemes used in the RX02: double frequency (FM) and modified Miller code (MFM). The FM scheme is used for single density data recording which is compatible with IBM system 3740 devices. (When this recording scheme is used and the RX02 is configured as shown in Figure 1-1 part C, the RX02 is compatible with the RX01.) The MFM scheme is used for double density data recording which is compatible with DIGITAL double density devices but is not compatible with other manufacturers.

1.5.2.1 Double Frequency (FM) – For the double frequency recording scheme data is recorded between bits of a constant clock stream. The clock stream consists of a continuous pattern of one flux reversal every four μs (Figure 1-7). A data “one” is indicated by an additional reversal between clocks (i.e., doubling the bit stream frequency; hence the name). A data “zero” is indicated by no flux reversal between clocks.

A continuous stream of ones, shown in the bottom waveform in Figure 1-7, would appear as a “2F” bit stream, and a continuous stream of zeros, shown in the top waveform in Figure 1-7, would appear as a “1F” or fundamental frequency bit stream.

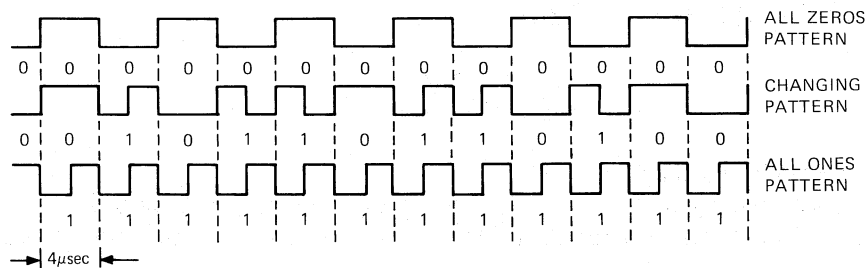

Figure 1-7 Flux Reversal Patterns for FM

1.5.2.2 Miller Code (MFM) – MFM or Miller code encodes clocks between data bits of a continuous data stream. The data stream consists of flux reversals for a data “one” and no flux reversal for a data “zero.” A clock is recorded only between data “zeros.” Because it is possible to have double density data fields map into a preamble and ID mark, the MFM encoding is modified slightly to prevent a false header from being detected within a double density data field.

NOTE

The modified MFM encoding is not compatible with other manufacturers.

The encoding algorithms for implementing modified MFM are:

Encoding Algorithm #1 (MFM or Miller Code Algorithm)

Dn	Data Dn + 1	Encoded Data		
		Dn	Cn	Dn + 1
0	0	0	1	0
1	0	1	0	0
0	1	0	0	1
1	1	1	0	1

Encoding Algorithm #2 (MFM Modified Algorithm)

Data					
D _n	D _{n + 1}	D _{n + 2}	D _{n + 3}	D _{n + 4}	D _{n + 5}
0	1	1	1	1	0

Encoded Data										
D _n	C _n	D _{n + 1}	C _{n + 1}	D _{n + 2}	C _{n + 2}	D _{n + 3}	C _{n + 3}	D _{n + 4}	C _{n + 4}	D _{n + 5}
0	1	0	0	0	1	0	0	0	1	0

The decoding algorithm used in data separation is:

Encoded			Decoded	
D _n	C _n	D _{n + 1}	D _n	D _{n + 1}
0	0	0	1	1
0	1	0	0	0
1	0	0	1	0
0	0	1	0	1
1	0	1	1	1

Figure 1-8 shows the waveforms that are generated for a data stream of zeros and ones when FM code, MFM code, and modified MFM code are used.

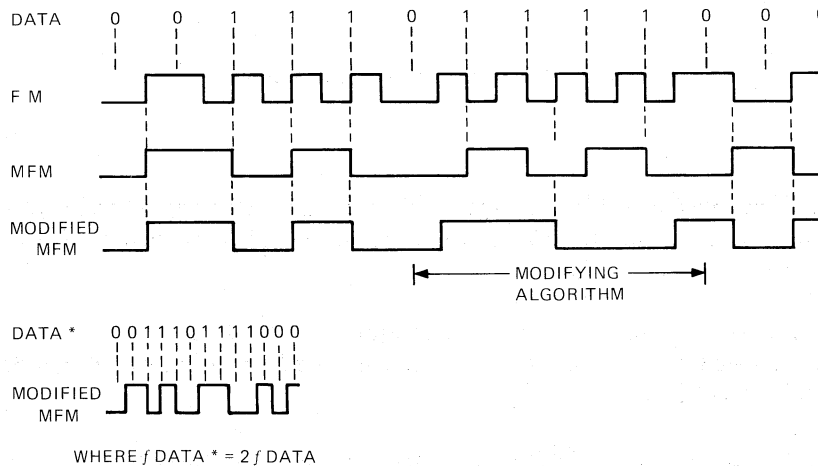

Figure 1-8 FM versus MFM Encoding

1.5.3 Logical Format

Data is recorded on only one side of the diskette. This surface is divided into 77 concentric circles or "tracks" numbered 0-76. Each track is divided into 26 sectors numbered 1-26 (Figure 1-9). Each sector contains two major fields: the header field and the data field (Figure 1-10).

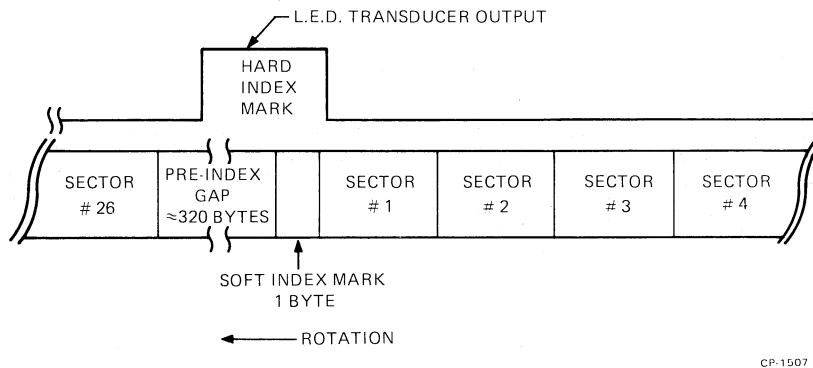

Figure 1-9 Track Format (Each Track)

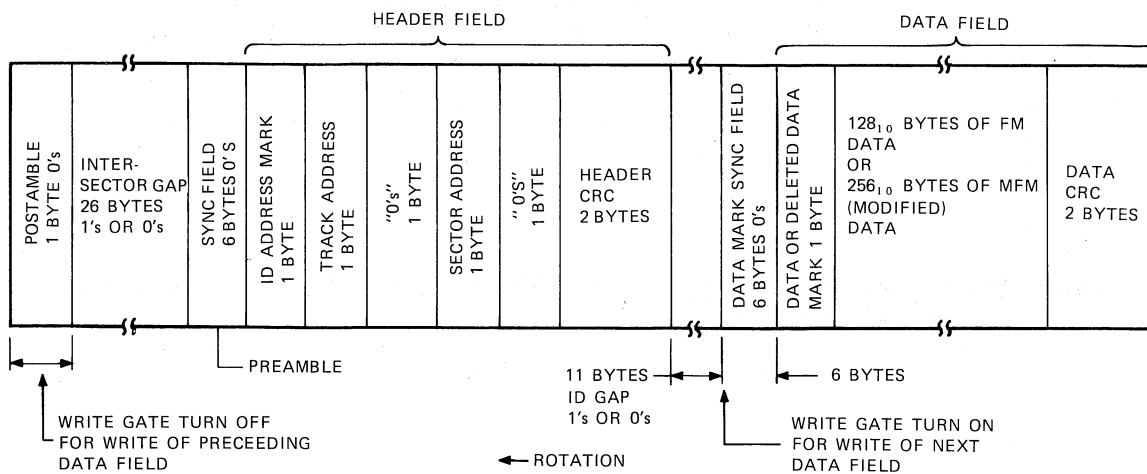

Figure 1-10 Sector Format (Each Sector)

1.5.3.1 Header Field Description - The header field is broken into seven bytes (eight bits/byte) of information and is preceded by a field of at least six bytes of zeros for synchronization. The header and its preamble are always recorded in FM.

1. **Byte No. 1: ID Address Mark** - This is a unique stream of flux reversals (not a string of data bits) that is decoded by the controller to identify the beginning of the header field. (Data = FE hex, clock = C7 hex.)
2. **Byte No. 2: Track Address** - This is the absolute (0-114₈) binary track address. Each sector contains track address information to identify its location on 1 of the 77 tracks.
3. **Byte No. 3: - Zeros**

4. Byte No. 4: Sector Address – This is the absolute binary sector address (1–32₈). Each sector contains sector address information to identify its circumferential position on a track. There is no sector 0.
5. Byte No. 5: – Zeros
- 6,7. Bytes No. 6 and 7: CRC – This is the cyclic redundancy check character that is calculated for each sector from the first five header bytes using the IBM 3740 polynomial.

1.5.3.2 Data Field Description – The data field contains either 131₁₀ or 259₁₀ bytes of information depending on the recording scheme. This field is preceded by a field of zeros for synchronization and the header field (Figure 1-10).

1. Byte No. 1: Data or Deleted Data Address mark – This byte is always recorded in FM and is unique because it contains missing clocks. It is decoded by the controller to identify the beginning of a data field. The deleted data mark is not used during normal operation but the RX02 can identify and write deleted data marks under program control as required. There is a unique address mark for each density as shown in the following table. One of these marks is the first byte of each data field.

Table 1-1 Data Address Mark Code

Mark	Density	Hex Byte	
		Data	Clock
Data	FM	FB	C7
	MFM mod.	FD	C7
DELETED DATA	FM	F8	C7
	MFM mod.	F9	C7

2. Bytes No. 2: –129 (FM) or –257 (MFM modified) – This is the data field and it can be recorded in either FM or MFM (modified). It is used to store 128₁₀ or 256₁₀ (depending upon encoding) 8-bit bytes of information.

NOTE

Partial data fields are not recorded.

3. Bytes No. 130 and 131 or 258 and 259 – These bytes comprise the CRC character that is calculated for each sector from the first 129 or 257 data field bytes using the industry standard polynomial division algorithm designed to detect the types of failures most likely to occur in recording on the floppy media. These bytes will be recorded with the same encoding scheme as the data field.

1.5.3.3 Track Usage – In the IBM 3740 system, some tracks are commonly designated for special purposes such as error information, directories, spares, or unused tracks. The RX02 is capable of recreating any system structure through the use of special systems programs, but normal operation will make use of all the available tracks as data tracks. Any special file structures must be accomplished through user software.

1.5.3.4 CRC Capability – Each sector has a two-byte header CRC character and a two-byte data CRC character to ensure data integrity. The CRC characters are generated by the hardware during a write operation and checked to ensure all bits were read correctly during a read operation. The CRC character is the same as that used in IBM 3740 series equipment.

CHAPTER 2 INSTALLATION

This chapter contains information that is required for site preparation, unpacking, installation, and testing of the RX02 Floppy Disk System. Information is also provided to identify the various system configurations that are available.

2.1 SITE PREPARATION

2.1.1 Space

The RX02 is a cabinet-mountable unit that may be installed in a standard Digital Equipment Corporation cabinet. This rack-mountable version is approximately 28 cm high, (10-1/2 inches), 48 cm wide, (19 inches) and 42 cm deep (16-1/2 inches) as shown in Figure 2-1.

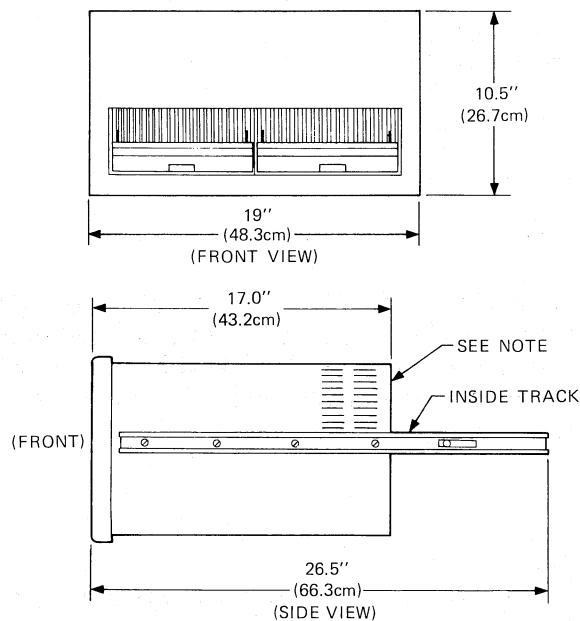

NOTE:
DUST COVER ATTACHED TO
CABINET NOT RX02

MA-1825

Figure 2-1 RX02 Outline Dimensions

When the RX02 is mounted in a cabinet (Figure 2-2), provision should be made for service clearances of approximately 56 cm (22 inches) at the front and rear of the cabinet so that the RX02 can be extended or the cabinet rear door opened.

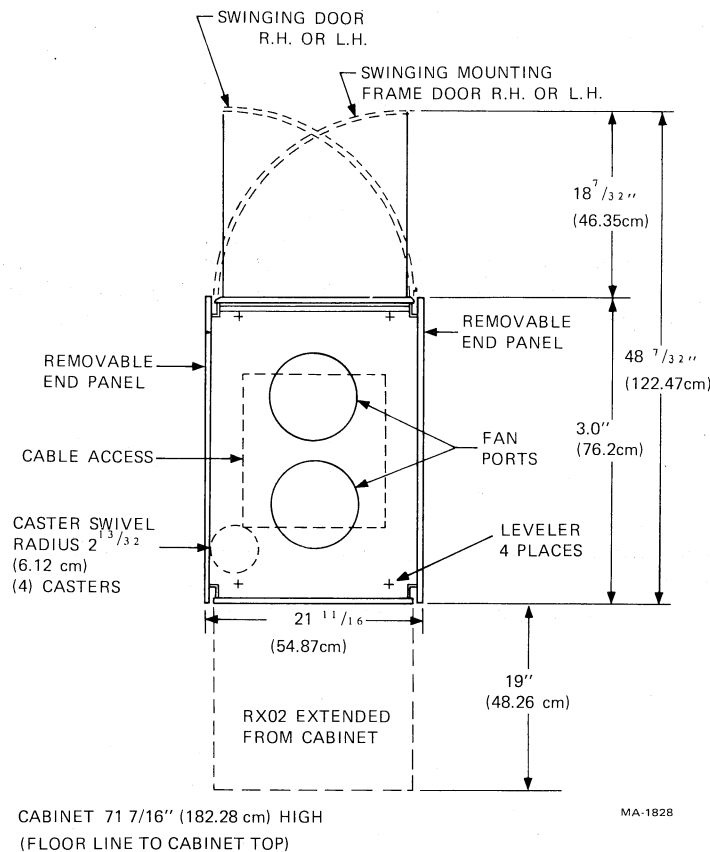

Figure 2-2 Cabinet Layout Dimensions

2.1.2 Cabling

The standard interface cable provided with an RX02 (BC05L-15) is 4.6 m (15 ft) in length; the positioning of the RX02 in relation to the central processor should be planned to take this into consideration. The RX02 should be placed near the control console or keyboard so that the operator will have easy access to load or unload disks. The position immediately above the CPU is preferred. The ac power cord is about 2.7 m (9 ft) long.

2.1.3 AC Power

2.1.3.1 Power Requirements – The RX02 is designed to use either a 60 Hz or a 50 Hz power source. The 60 Hz version will operate from 90–128 Vac, without modifications, and will use less than 4 A operating. The 50 Hz version will operate within four voltage ratings and will require field verification/modification to ensure that the correct voltage option is selected. The voltage ranges of 90–120 Vac and 184–240 Vac will use less than 4 A operating. The voltage ranges of 100–128 Vac and 200–256 Vac will use less than 2 A. Both versions of the RX02 will be required to receive the input power from an ac source (e.g., 861 power control) that is controlled by the system's power switch.

2.1.3.2 Input Power Modification Requirements – The 60 Hz version of the RX02 uses the H771-A power supply and will operate on 90–128 Vac, without modification. To convert to operate on a 50 Hz power source in the field, the H771-A supply must be replaced with an H771-C or -D (Figure 1-4) and the drive motor belt and drive motor pulley must be replaced (Figure 1-5). The H771-C operates on a 90–120 Vac or 100–128 Vac power source. The H771-D operates on a 184–240 Vac or 200–256 Vac power source. To convert the H771-C to the higher voltage ranges or the H771-D to the lower voltage ranges, the power harness and circuit breaker must be changed. See Figure 2-3 for the appropriate jumper and circuit breaker.

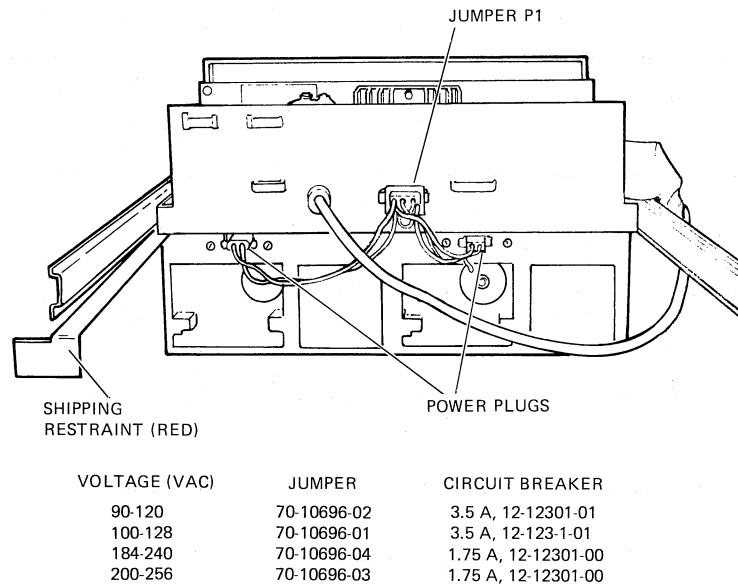

MA-1855

Figure 2-3 RX02 Rear View

2.1.4 Fire and Safety Precautions

The RX02 Floppy Disk System presents no additional fire or safety hazards to an existing computer system. Wiring should be carefully checked, however, to ensure that the capacity is adequate for the added load and for any contemplated expansion.

2.2 CONFIGURATION GUIDELINES

The most common RX02 Floppy Disk System configurations available are listed in Table 2-1. Each interface module listed in the table plugs into a computer bus; it is compatible with the applicable computer so that there is adequate power to operate each module. The interconnections between each interface module and the RX02 controller for each of the configurations in Table 2-1 is by a BC05L-15 cable which is 4.6 m (15 ft) maximum. (See Table 2-2 for the controller module configuration switch positions.)

Table 2-1 RX02 Configurations

Computer	System Designation	μ CPU Controller	Interface Module	RX02 Model No.	Power Supply
PDP-8	RX8E	M7744	M8357	RX02-BA RX02-BC RX02-BD	115 V, 60 Hz 115 V, 50 Hz 230 V, 50 Hz
	RX28E	M7744	M8357	RX02-BA RX02-BC RX02-BD	115 V, 60 Hz 115 V, 50 Hz 230 V, 50 Hz
PDP-11	RX11	M7744	M7846	RX02-BA RX02-BD RX02-BD	115 V, 60 Hz 230 V, 50 Hz 230 V, 50 Hz
	RX211	M7744	M8256	RX02-BA RX02-BC RX02-BD	115 V, 60 Hz 115 V, 50 Hz 230 V, 50 Hz
LSI-11	RXV11	M7744	M7946	RX02-BA RX02-BC RX02-BD	115 V, 60 Hz 115 V, 50 Hz 230 V, 50 Hz
	RXV21	M7744	M8029	RX02-BA RX02-BC RX02-BD	115 V, 60 Hz 115 V, 50 Hz 230 V, 50 Hz

Table 2-2 Controller Configuration Switch Positions

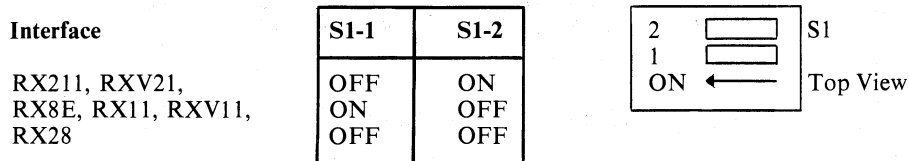

2.3 ENVIRONMENTAL CONSIDERATIONS

2.3.1 General

The RX02 is capable of efficient operation in computer environments; however, the parameters of the operating environment must be determined by the most restrictive facets of the system, which in this case are the diskettes.

2.3.2 Temperature, Relative Humidity

The operating ambient temperature range of the diskette is 15° to 32° C (59° to 90° F) with a maximum temperature gradient of 11° C/hr (20° F/hr). The media nonoperating temperature range (storage) is increased to -34.4° to 51.6° C (-30° to 125° F), but care must be taken to ensure that the media has stabilized within the operating temperature range before use. This range will ensure that the media will not be operated above its absolute temperature limit of 51.6° C (125° F).

Humidity control is important in any system because static electricity can cause errors in any CPU with memory. The RX02 is designed to operate efficiently within a relative humidity range of 20 to 80 percent, with a maximum wet bulb temperature of 25° C (77° F) and a minimum dew point of 2° C (36° F).

2.3.3 Heat Dissipation

The heat dissipation factor for the RX02 Floppy Disk System is less than 225 Btu/hr. By adding this figure to the total heat dissipation for the other system components and then adjusting the result to compensate for such factors as the number of personnel, the heat radiation from adjoining areas, and sun exposure through windows, the approximate cooling requirements for the system can be determined. It is advisable to allow a safety margin of at least 25 percent above the maximum estimated requirements.

2.3.4 Radiated Emissions

Sources of radiation, such as FM, vehicle ignitions, and radar transmitters located close to the computer system, may affect the performance of the RX02 Floppy Disk System because of the possible adverse effects magnetic fields can have on diskettes. A magnetic field with an intensity of 50 oersteds or greater might destroy all or some of the information recorded on the diskette.

2.3.5 Cleanliness

Although cleanliness is important in all facets of a computer system, it is particularly important in the case of moving magnetic media, such as the RX02. Diskettes are not sealed units and are vulnerable to dirt. Such minute obstructions as dust specks or fingerprint smudges may cause data errors. Therefore, the RX02 should not be subjected to unusually contaminated atmospheres, especially one with abrasive airborne particles.

NOTE

Removable media involve use, handling, and maintenance which are beyond DIGITAL's direct control. DIGITAL disclaims responsibility for performance of the equipment when operated with media not meeting DIGITAL specifications or with media not maintained in accordance with procedures approved by DIGITAL. DIGITAL shall not be liable for damages to the equipment or to media resulting from such operation.

2.4 UNPACKING AND INSPECTION

2.4.1 General

The RX02 Floppy Disk System can be shipped in a cabinet as an integral part of a system or in a separate container. If the RX02 is shipped in a cabinet, the cabinet should be positioned in the final installation location before proceeding with the installation.

2.4.2 Tools

Installation of an RX02 Floppy Disk System requires no special tools or equipment. Normal hand tools are all that are necessary. However, a forklift truck or pallet handling equipment may be needed for receiving and installing a cabinet-mounted system.

2.4.3 Unpacking

2.4.3.1 Cabinet-Mounted

1. Remove the protective covering over the cabinet.
2. Remove the restraint on the rear door latch and open the door.
3. Carefully roll the cabinet off the pallet; if a forklift is available, it should be used to lift and move the cabinet.
4. Remove the shipping restraint from the RX02 and save it for possible reuse.
5. Slide the RX02 out on the chassis slides and visually inspect for any damage as indicated in Paragraph 2.4.3.3.

2.4.3.2 Separate Container

1. Open the carton (Figure 2-4) and remove the packing pieces.
2. Lift the RX02 out of the carton.
3. Remove the shipping fixtures from both sides of the RX02 and inspect for shipping damage as indicated in Paragraph 2.4.3.3.
4. Attach the inside tracks of the chassis slides provided in the carton to the RX02 (Figure 2-1).
5. Locate the proper holes in the cabinet rails (Figure 2-5) and attach the outside tracks to the cabinet.
6. Place the tracks attached to the RX02 inside the extended cabinet tracks and slide the unit in until the tracks lock in the extended position.
7. Attach the front bezel with the screws supplied.
8. Locate the RX02 cover in the cabinet above the unit and secure it to the cabinet rails (Figure 2-5).

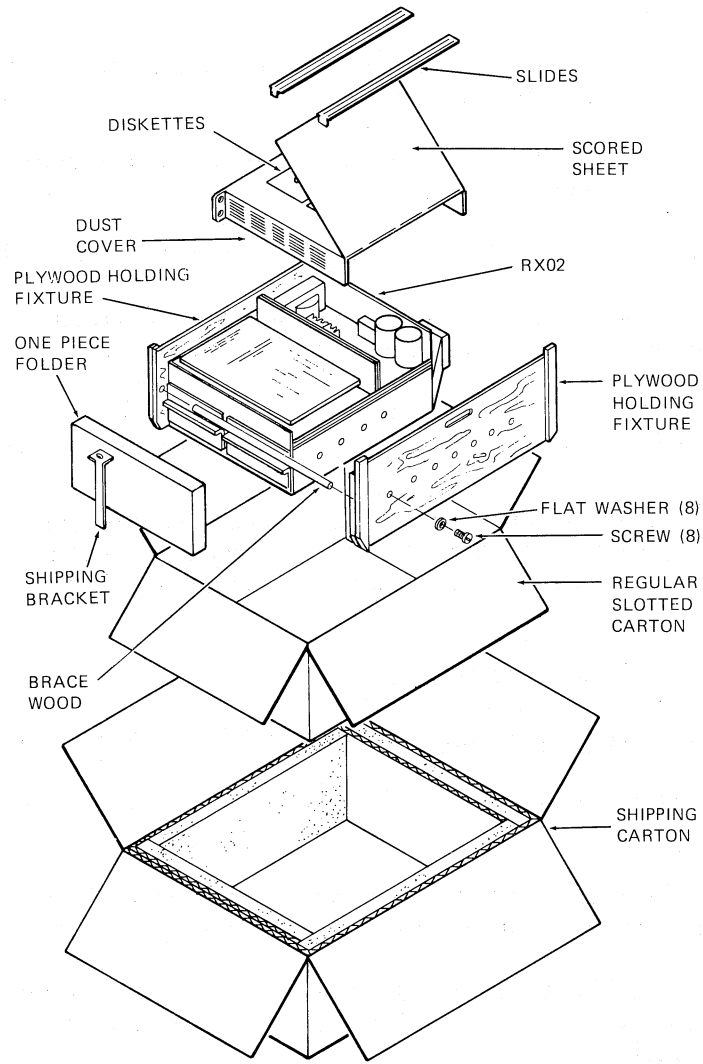

MA-1854

Figure 2-4 RX02 Unpacking

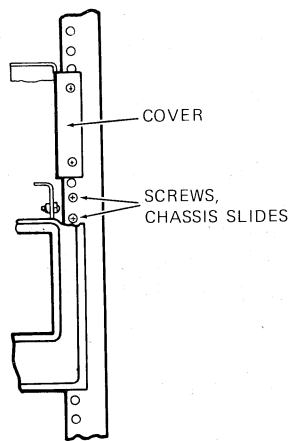

CP-1594

Figure 2-5 RX02 Cabinet Mounting Information

2.4.3.3 Inspection

1. Inspect the front cover(s) of the RX02 to be sure it operates freely. Compress the latch which allows the spring-loaded front cover to open.
2. Inspect the rear of the RX02 chassis to be sure there are no broken or bent plugs. Also, be sure the fuse is not damaged.
3. Visually inspect the interior of the unit for damaged wires or loose hardware.
4. Loosen the screws securing the hinged upper module (M7744) and raise the module so that modules M7744 and M7745 can be inspected for damaged components or wires.
5. Verify that the items listed on the shipping order are included in the shipment. Be sure the interface cable (BC05L-15) and the appropriate interface module are included.

NOTE

If any shipping damage is found, the customer should be notified at this time so he can contact the carrier and record the information on the acceptance form.

2.5 INSTALLATION

1. Ensure that power for the system is off.
2. Loosen the screws securing the upper module (M7744) and swing it up on the hinge.
3. Inspect the wiring and connectors for proper routing and ensure that they are seated correctly.
4. This step is for 50 Hz versions only. Check the power configuration to ensure that the proper jumpers and the correct circuit breaker are installed (Figure 2-3).
5. Connect the BC05L-15 cable to the M7744 module and route it along the near side of the chassis through the back of the RX02 to the CPU; then connect it to the interface module for the PDP-8, PDP-11, or LSI-11.

The cable is connected to the M7744 module with the red stripe on the left, looking from the component side of board; the cable is connected to the interface module with the red stripe toward the center of the module.

6. Refer to Table 2-2 for the correct controller configuration switch positions.
7. Refer to Table 2-3 for correct device code or addressing jumpers on the interface module.
8. Insert the interface module into the Omnibus (PDP-8), available SPC slot (PDP-11), or LSI bus (LSI-11). The PDP-11 and LSI-11 interface modules must be inserted in the lowest numbered available option location. Modules that use DMA processing should have a higher priority than programmed I/O devices. For modules using DMA processing in the PDP-11 SPC slot, ensure that the NPG (NPG IN, NPG OUT) line (CA1-CB1) is cut on the backplane.
9. Connect the RX02 ac power cord into a switched power source.
10. Turn the power on, watching for head movement on the drive(s) during the power up, initialize phase. The head(s) should move one track toward the center and back to track zero.

Table 2-3 Interface Code/Jumper Configuration

PDP-8 (M8357)						
Device Codes						
	SW1	SW2	SW3	SW4	SW5	SW6
670X*	ON	ON	ON	OFF	OFF	OFF
671X	ON	ON	OFF	OFF	OFF	ON
672X	ON	OFF	ON	OFF	ON	OFF
673X	ON	OFF	OFF	OFF	ON	ON
674X	OFF	ON	ON	ON	OFF	OFF
675X	OFF	ON	OFF	ON	OFF	ON
676X	OFF	OFF	ON	ON	ON	OFF
677X	OFF	OFF	OFF	ON	ON	ON

PDP-11 (M7846) (M8256)				
BR Priority	Unibus Address 17717X*		Vector Address (264 ₈)*	
BR7 - 54-08782	A12/W18 - Removed	SW1 OFF	V2/W1 - Installed	SW1 ON
BR6 - 54-08780	A11/W17 - Removed	SW2 OFF	V3/W2 - Removed	SW2 OFF
BR5 - 54-08778*	A10/W16 - Removed	SW3 OFF	V4/W3 - Installed	SW3 ON
BR4 - 57-08776	A9/W15 - Removed	SW4 OFF	V5/W4 - Installed	SW4 ON
	A8/W14 - Installed	SW5 ON	V6/W5 - Removed	SW5 OFF
	A7/W13 - Installed	SW6 ON	V7/W6 - Installed	SW6 ON
	A6/W12 - Removed	SW7 ON	V8/W7 - Removed	SW7 OFF
	A5/W11 - Removed	SW8 OFF		
	A4/W10 - Removed	SW9 OFF		
	A3/W9 - Removed	SW10 OFF		

LSI-11			
(M7946)		(M8029)	
Register Address* (17717X ₈)	Vector Address* (264 ₈)	Register Address* (17717X ₈)	Vector Address* (264 ₈)
A-1 - CPU Selectable	W-1/V-2 - Removed	A-1 - CPU Selectable	V2 - Installed
W-7/A-2 - Installed	W-2/V-3 - Installed	A-2 - Hardwired	V-3 - Removed
W-8/A-3 - Removed	W-3/V-4 - Removed	A-3 - Installed	V-4 - Installed
W-9/A-4 - Removed	W-4/V-5 - Removed	A-4 - Installed	V-5 - Installed
W-10/A-5 - Removed	W-5/V-6 - Installed	A-5 - Installed	V-6 - Removed
W-11/A-6 - Removed	W-6/V-7 - Removed	A-6 - Installed	V-7 - Installed
W-12/A-7 - Installed		A-7 - Removed	V-8 - Removed
W-13/A-8 - Installed		A-8 - Removed	
W-14/A-9 - Removed		A-9 - Installed	
W-15/A-10 - Removed		A-10 - Installed	
W-16/A-11 - Removed		A-11 - Installed	
W-17/A-12 - Removed		A-12 - Installed	

*Standard

2.5.1 PDP8-A Modification

In order to bootload from an RX02 on a PDP8-A system, it is necessary to modify the KM8-A (M8317) extended option module (if present) as follows (Figure 2-6):

- replace E82 with prom #23-465A2
- replace E87 with prom #23-469A2
- set SW#1 and SW#2 according to the bootload device as shown below.

Program	S2-5	S2-6	S2-7	S2-8	S1-1	S1-2	S1-3
H/L PTR	ON	ON	ON	OFF	ON	ON	ON
RK8-E	ON	OFF	ON	OFF	ON	OFF	ON
RX8-E	ON	OFF	OFF	ON	OFF	ON	ON
RL8A	OFF	ON	OFF	OFF	OFF	ON	OFF

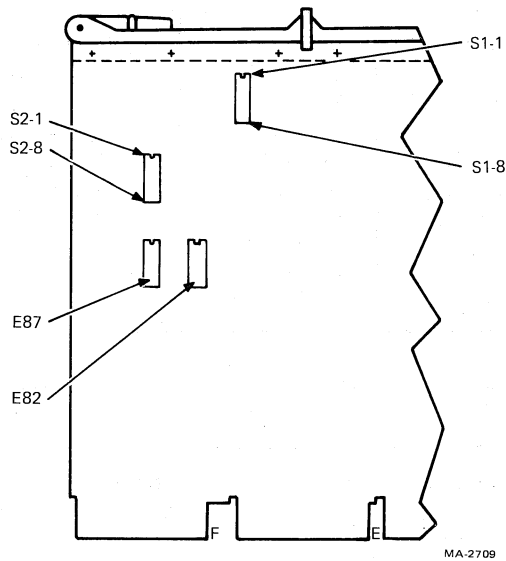

Figure 2-6 KM8-A Modification

2.6 TESTING

To test the operation of RX02, run the DEC diagnostics supplied. Perform the diagnostics in the sequence listed for the number of passes (time) indicated.

- RX8 or RX11 Diagnostic - 2 passes
- Data Reliability/Exerciser - 3 passes
- DECX-8 or DECX-11 - 10 minutes

If any errors occur contact Field Service.

CHAPTER 3

USER INFORMATION

3.1 CUSTOMER RESPONSIBILITY

It is the user's responsibility to ensure that the RX02 is located and operated in an area that is free from excessive dust and dirt, and meets or exceeds the environmental conditions listed in Paragraph 1.4. The exterior of the RX02 should be kept clean. Also, it is the user's responsibility to ensure that the diskettes are handled and stored properly in order to prevent errors or data loss which might occur when recording or reading data; diskette handling procedures are described in Paragraph 3.2.

3.2 CARE OF MEDIA

3.2.1 Handling Practices and Precautions

To prolong the diskette life and prevent errors when recording or reading, reasonable care should be taken when handling the media. The following handling recommendations should be followed to prevent unnecessary loss of data or interruptions of system operation.

1. Do not write on the envelope containing the diskette. Write any information on a label prior to affixing it to the diskette.
2. Paper clips should not be used on the diskette.
3. Do not use writing instruments that leave flakes, such as lead or grease pencils, on the jacket of the media.
4. Do not touch the disk surface exposed in the diskette slot or index hole.
5. Do not clean the disk in any manner.
6. Keep the diskette away from magnets or tools that may have become magnetized. Any disk exposed to a magnetic field may lose information.
7. Do not expose the diskette to a heat source or sunlight.
8. Always return the diskette to the envelope supplied with it to protect the disk from dust and dirt. Diskettes not being used should be stored in a file box if possible.
9. When the diskette is in use, protect the empty envelope from liquids, dust, and metallic materials.
10. Do not place heavy items on the diskette.

11. Do not store diskettes on top of computer cabinets or in places where dirt can be blown by fans into the diskette interior.
12. If a diskette has been exposed to temperatures outside the operating range, allow five minutes for thermal stabilization before use. The diskette should be removed from its packaging during this time.

CAUTION

- **Do not use paper clips on diskettes.**
- **Do not expose the diskette to a heat source or sunlight.**
- **Keep the diskettes from magnetic fields.**
- **Do not write on the diskette with an instrument that leaves an impression or flakes.**

3.2.2 Diskette Storage

3.2.2.1 Short Term (Available for Immediate Use)

1. Store diskettes in their envelopes.
2. Store horizontally, in piles of ten or less. If vertical storage is necessary, the diskettes should be supported so that they do not lean or sag, but should not be subjected to compressive forces. *Permanent deformation may result from improper storage.*
3. Store in an environment similar to that of the operating system; at a minimum, store within the operating environment range.

3.2.2.2 Long Term – When diskettes do not need to be available for immediate use, they should be stored in their original shipping containers within the nonoperating range of the media.

3.2.3 Shipping Diskettes

Data recorded on disks may be degraded by exposure to any sort of small magnet brought into close contact with the disk surface. If diskettes are to be shipped in the cargo hold of an aircraft, take precautions against possible exposure to magnetic sources. Because physical separation from the magnetic source is the best protection against accidental erasure of a diskette, diskettes should be packed at least 3 inches within the outer box. This separation should be adequate to protect against any magnetic sources likely to be encountered during transportation, making it generally unnecessary to ship diskettes in specially shielded boxes.

When shipping, be sure to label the package:

DO NOT EXPOSE TO PROLONGED HEAT OR SUNLIGHT.

When received, the carton should be examined for damage. Deformation of the carton should alert the receiver to possible damage of the diskette. The carton should be retained, if it is intact, for storage of the diskette or for future shipping.

3.3 OPERATING INSTRUCTIONS

NOTE

The left drive is always identified as drive 0.

The RX02 has no operator controls and indicators. The diskette is inserted on a drive after compressing the latch to allow the spring-loaded front cover to open. Place the diskette with the label or top up (the jacket seams are on the bottom) on the drive spindle. Close the front cover which will automatically lock when it is pushed down. Initialize the system (from the computer) and listen for audible clicking sounds which indicate the head is moving over the diskette; the RX02 is ready for use. Data storage and retrieval is controlled by the user's program.

CAUTION

Do not open the drive door while the diskette is in use; this results in errors.

3.4 OPERATOR TROUBLESHOOTING

Table 3-1 is a list of possible problems and some probable causes the operator may encounter. If the problem cannot be corrected, refer to the *RX02 Floppy Disk System Technical Manual* if available.

Table 3-1 Operator Troubleshooting Guide

Problem	Probable Cause	Correction
No power (drive inoperative)	a. Power cord disconnected b. Blown fuse c. Circuit breaker open	a. Connect power cord b. Replace fuse c. Close circuit breaker
Drive not ready	a. Drive door open b. Diskette improperly installed	a. Close door b. Properly seat diskette
Error in recording	a. Diskette wear b. Diskette mounting hole c. Mismatch in recording density on a diskette	a. If worn, replace b. If the hole is not concentric, replace diskette c. If diskette data density is not compatible with data to be recorded, replace diskette with a new preformatted diskette.

CHAPTER 4 PROGRAMMING

This chapter contains programming information for the following interface options: RX8E, RX28, RX11, RXV11, RX211, and RXV21. The RX8E and RX28 programming information is presented followed by the RX11 and RXV11 information and then the RX211 and RXV21 information is presented. The RX8E, RX11, and RXV11 options are used for single density recording and are compatible with the RX01 Floppy Disk System. The RX28E, RX211, and RXV21 can be used for either single or double density recording.

4.1 RX8E AND RX28 PROGRAMMING INFORMATION

The RX8E interface allows two modes of data transfer: 8-bit word length and 12-bit word length. In the 12-bit mode, 64 words are written in a diskette sector, thus requiring 2 sectors to store 1 page of information. The diskette capacity in this mode is 128,128 12-bit words (1001 pages). In the 8-bit transfer mode, 128 8-bit words are written in each sector. Disk capacity is 256,256 8-bit words, which is a 33 percent increase in disk capacity over the 12-bit mode. The 8-bit mode must be used for generating IBM-compatible diskettes, since 12-bit mode does not fully pack the sectors with data. The hardware puts in the extra 0s. Data transfer requests occur 23 ms after the previous request was serviced for 12-bit mode (18 ms for 8-bit mode). There is no maximum time between the transfer request from the RX02 and servicing of that request by the host processor. This allows the data transfer to and from the RX02 to be interrupted without loss of data.

The RX28 interface allows two modes of data transfer: 8-bit word length and 12-bit word length. For each mode of data transfer there can be either single density or double density storage of data. In the 12-bit mode single density recording, 64 words are written in a diskette sector, and the diskette capacity is 128,128 12-bit words; for double density, there are 128 words written in a sector with a diskette capacity of 256,256 12-bit words. In the 8-bit word mode single density recording, 128 8-bit bytes are written in each sector and the diskette capacity is 256,256 8-bit bytes; for double density, there are 256 8-bit bytes written in a sector with a diskette capacity of 512,512 8-bit bytes. (For the 12-bit mode, all 12-bit data words are loaded into the buffer and then the hardware forces zeros to add extra bits to the end of the buffer so that the buffer is filled.)

4.1.1 Device Codes

The eight possible device codes that can be assigned to the interface are 70-77. These device codes define address locations of a specific device and allow up to eight RX8E/RX28 interfaces to be used on a single PDP-8. These multiple device codes are also shared with other devices. Depending on what other devices are on the system, the RX8E/RX28 device code can be selected to avoid conflicts. (Refer to the *PDP-8 Small Computer Handbook* for specific device codes.)

The device codes are selected by switches according to Table 4-1. These switches control ac bits 6-8, while ac bits 3-5 are fixed at 1s. The device code is initially selected to be 70. Switches 7 and 8 are not connected and will not affect the device selection code. The switches are all located on a single DIP switch package that is located on the M8357 RX8E/RX28 interface board.

Table 4-1 Device Code Switch Selection

Device Code	S1	S2	S3	S4	S5	S6	S7	S8
77	0	0	0	1	1	1	X	X
76	0	0	1	1	1	0	X	X
75	0	1	0	1	0	1	X	X
74	0	1	1	1	0	0	X	X
73	1	0	0	0	1	1	X	X
72	1	0	1	0	1	0	X	X
71	1	1	0	0	0	1	X	X
70	1	1	1	0	0	0	X	X

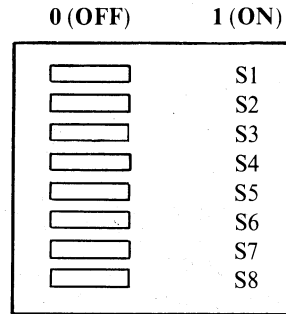

4.1.2 Instruction Set

The RX8E/RX28 instruction set is listed below and described in the following paragraphs. When operating as an RX28, for the 8-bit mode, all instruction set commands are transferred in two 8-bit bytes.

IOT	Mnemonic	Description
67x0		No Operation
67x1	LCD	Load Command, Clear AC
67x2	XDR	Transfer Data Register
67x3	STR	Skip on Transfer Request Flag, Clear Flag
67x4	SER	Skip on Error Flag, Clear Flag
67x5	SDN	Skip on Done Flag, Clear Flag
67x6	INTR	Enable or Disable Disk Interrupts
67x7	INIT	Initialize Controller and Interface

4.1.2.1 RX8E Load Command (LCD) - 67x1 - This command transfers the contents of the AC to the interface register and clears the AC. The RX02 begins to execute the function specified in AC 8, 9, and 10 on the drive specified by AC 7. A new function cannot be initiated unless the RX02 has completed the previous function. The command word is defined as shown in Figure 4-1. The command word is described in greater detail in Paragraph 4.1.3.1.

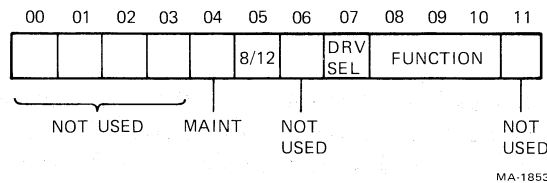

Figure 4-1 LCD Word Format (RX8E)

4.1.2.2 RX28 Load Command – (First byte 67x1, second byte – 67x2) – This command transfers the contents of the AC to the interface register and clears the AC. The RX02 begins to execute the function specified in AC 8, 9, and 10 on the drive specified by AC 7. A new function cannot be initiated unless the RX02 has completed the previous function. The command word is defined as shown in Figure 4-2 and is described in greater detail in Paragraph 4.1.3.1.

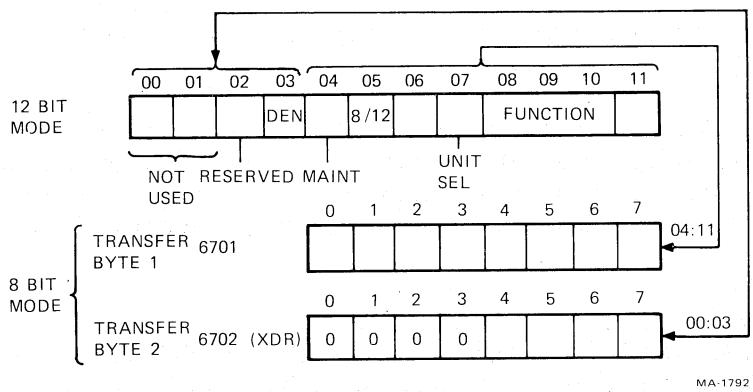

Figure 4-2 Command Word Format (RX28)

When operating in the 8-bit mode, the Load command is stored in two 8-bit transfers. The first 8 bits of the command word (shown as bits 4–11 in Figure 4-2) are stored; then TR is asserted and an XDR is performed to transfer the remaining bits of data (bit 3, DEN, and bit 2, as shown in Figure 4-2) right-justified. The extra bits in the second 8-bit transfer are filled with zeros. Upon completing the transfer of the second 8-bit byte, Done is asserted to end the function.

4.1.2.3 Transfer Data Register (XDR) – 67x2 – With the maintenance flip-flop cleared, this instruction operates as follows. A word is transferred between the AC and the interface register. The direction of transfer is governed by the RX02 and the length of the word transferred is governed by the mode selected (8-bit or 12-bit). When Done is negated, executing this instruction indicates to the RX02 that:

1. The last data word supplied by the RX02 has been accepted by the PDP-8, and the RX02 can proceed, or
2. The data or address word requested by the RX02 has been provided by the PDP-8, and the RX02 can proceed.

A data transfer (XDR) from the AC always leaves the AC unchanged. If operation is in 8-bit mode, AC 0–3 are transferred to the interface register but are ignored by the RX02. Transfers into the AC are 12-bit jam transfers when in 12-bit mode. When in 8-bit mode, the 8-bit word is ORed into AC 4–11 and AC 0–3 remain unchanged. When the RX02 is done, this instruction can be used to transfer the RXES status word from the interface register to the AC. The selected mode controls this transfer as indicated above.

4.1.2.4 STR – 67x3 – This instruction causes the next instruction to be skipped if the transfer request (TR) flag has been set by RX02 and clears the flag. The TR flag should be tested prior to transferring data or address words with the XDR instruction to ensure the data or address has been received or transferred, or after an LCD instruction to ensure the command is in the interface register. In cases where an XDR follows an LCD, the TR flag needs to be tested only once between the two instructions.

4.1.2.5 SER – 67x4 – This instruction causes the next instruction to be skipped if the error flag has been set by an error condition in the RX02 and clears the flag. An error also causes the done flag to be set (Paragraph 4.1.3.6).

4.1.2.6 SDN – 67x5 – This instruction causes the next instruction to be skipped if the done flag has been set by the RX02, indicating the completion of a function or detection of an error condition. If the done flag is set, it is cleared by the SDN instruction. This flag will interrupt if interrupts are enabled.

4.1.2.7 INTR – 67x6 – This instruction enables interrupts by the done flag if AC 11=1. It disables interrupts if AC 11=0.

4.1.2.8 INIT – 67x7 – The instruction initializes the RX02 by moving the head position mechanism of drive 1 (if drive 1 is available) to track 0. It reads track 1, sector 1 of drive 0. It zeros the error and status register and sets Done upon successful completion of Initialize. Up to 1.8 seconds may elapse before the RX02 returns to the Done state. Initialize can be generated by the program or by the Omnibus Initialize.

4.1.3 Register Description

Only one physical register (the interface register) exists in the RX8E/RX28, but it may represent one of the six RX02 registers described in the following paragraphs, according to the protocol of the function in progress.

4.1.3.1 Command Register (Figures 4-3 and 4-4) – The command is loaded into the interface register by the LCD instruction for RX8E and by a load command (LCD and XDR) for the RX28 (Paragraphs 4.1.2.1 and 4.1.2.2).

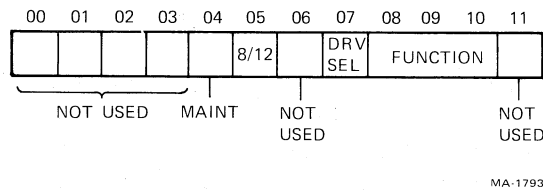

Figure 4-3 Command Register Format (RX8E)

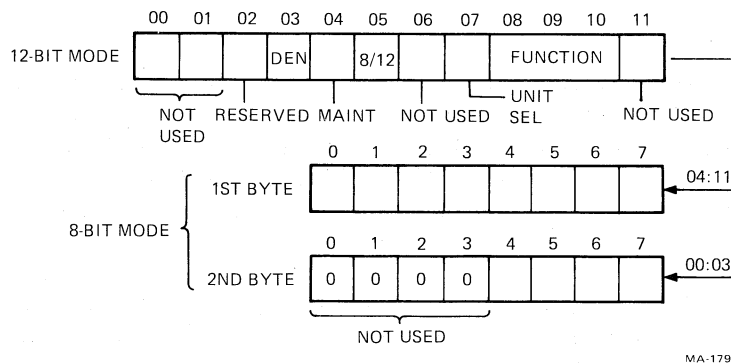

Figure 4-4 Command Register Format (RX28)

The function codes (bits 8, 9, 10) are summarized below and described in Paragraph 4.1.4.

Code	Function
000	Fill Buffer
001	Empty Buffer
010	Write Sector
011	Read Sector
100	Not used (RX8E) – Set Density (RX28)
101	Read Status
110	Write Deleted Data Sector
111	Read Error Register

The DRV (UNIT) SEL bit (bit 7) selects one of the two drives upon which the function will be performed:

AC 7 = 0	Select drive 0
AC 7 = 1	Select drive 1

The 8/12 bit (bit 5) selects the length of the data word.

AC 5 = 0	12-bit mode selected
AC 5 = 1	8-bit mode selected

The DEN bit (bit 3) for RX28 indicates the density for the function to be performed (0 = single, 1 = double). The RX8E/RX28 will initialize into 12-bit mode.

4.1.3.2 Error Code Register (Figure 4-5) – Specific error codes can be accessed by use of the read error code function (111) (Paragraph 4.1.4.9). The specific octal error codes are given in Paragraph 4.1.5.

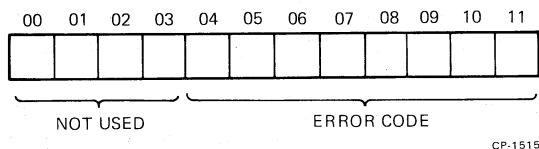

Figure 4-5 Error Code Register Format (RX8E/RX28A)

The maintenance bit (M bit) can be used to diagnose the RX8E interface under off-line and on-line conditions. The off-line condition exists when the BC05L-15 cable is disconnected from the RX02; the on-line condition exists when the cable is connected to the RX02.

If an LCD IOT (I/O transfer) is issued with AC 4 = 1, the maintenance flip-flop is set. When the maintenance flip-flop is set, the assertion of RUN following XDR instructions is inhibited, and all data register transfers (XDR) are forced into the AC. The maintenance bit allows the interface register to be written and read for maintenance checks. The maintenance flip-flop is cleared by Initialize or by a Load Command IOT with AC 4 = 0. The following paragraphs describe more explicitly how to use the maintenance bit in an off-line mode.

The contents of the interface buffer cannot be guaranteed immediately following the first Load Command IOT, which sets the maintenance flip-flop. However, successive Load Command IOTs will guarantee the contents of the interface register. The contents of the interface register can then be verified by using the XDR IOT to transfer those contents into the AC.

In addition, the maintenance flip-flop directly sets the skip flags, which will remain set as long as the maintenance flip-flop is set. Skipping on these flags as long as the maintenance flip-flop is set will not clear the flags. Setting and then clearing the maintenance flip-flop will leave the skip flags in a set condition. The skip IOTs can then be issued to determine whether or not a large portion of the interface skip logic is working correctly.

With the maintenance flip-flop set, it can be determined if the interface is capable of generating an interrupt on the Omnibus. When the maintenance flip-flop is set, the done flag is set, and the interrupt enable flip-flop can be set by issuing an INTR IOT with AC bit 11=1. The combination of done and interrupt enable should generate an interrupt.

The maintenance flip-flop can also be used to test the INIT IOT. The maintenance flip-flop is set and cleared to generate the flags, and INIT IOT is then executed. If execution of INIT IOT is internally successful, all of the flags and the interrupt enable flip-flop should be cleared if they were previously set.

In the on-line mode, use of the maintenance bit should be restricted to writing and reading the interface register. The same procedure described to write and read the interface register in the off-line mode should be implemented in the on-line mode. Exiting from the on-line maintenance bit mode should be finalized by an initialize to the RX02.

4.1.3.3 RX2TA – RX Track Address (Figure 4-6) – This register is loaded to indicate on which of the 77 (0-76) tracks a given function is to operate. It can be addressed only under the protocol of the function in progress (Paragraph 4.1.4). Bits 0-3 are unused and are ignored by the control.

4.1.3.4 RX2SA – RX Sector Address (Figure 4-7) – This register is loaded to indicate on which of the 26 (1-26) sectors a given function is to operate. It can be addressed only under the protocol of the function in progress (Paragraph 4.1.4). Bits 0-3 are unused and are ignored by the control.

4.1.3.5 RX2DB – RX Data Buffer (Figure 4-8) – All information transferred to and from the floppy media passes through this register and is addressable only under the protocol of the function in progress. The length of data transfer is either 8 or 12 bits, depending on the state of bit 5 of the command register when the Load Command IOT is issued (Paragraph 4.1.3.1).

4.1.3.6 RX8E – RX Error and Status (Figure 4-9) – The RXES contains the current error and status conditions of the selected drive. This read-only register can be accessed by the read status function (101). The RXES is also available in the interface register upon completion of any function. The RXES is accessed by the XDR instruction. The meaning of the error bits is given below.

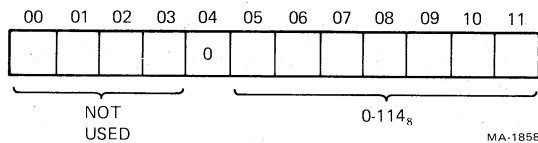

Figure 4-6 RX2TA Format (RX8E/RX28)

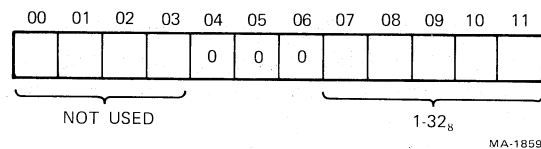

Figure 4-7 RX2SA Format (RX8E/RX28)

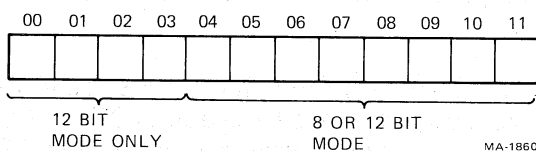

Figure 4-8 RX2DB Format (RX8E/RX28)

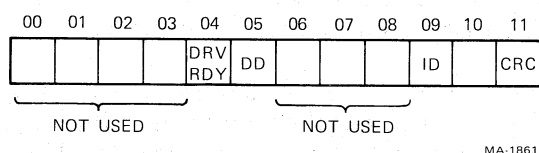

Figure 4-9 RXES Format (RX8E)

Bit No. Description

- 11 CRC Error – The cyclic redundancy check at the end of the data field has indicated an error. The data must be considered invalid; it is suggested that the data transfer be retried up to 10 times, as most data errors are recoverable (soft).
- 9 Initialize Done – This bit indicates completion of the Initialize routine. It can be asserted due to RX02 power failure, system power failure, or programmable or bus Initialize. This bit is not available within the RXES from a read status function.
- 5 Deleted Data (DD) – In the course of reading data, a deleted data mark was detected in the identification field. The data following will be collected and transferred normally as the deleted data mark has no further significance within the RX02. Any alteration of files or actual deletion of data due to this mark must be accomplished by user software. This bit will be set if a successful or unsuccessful Write Deleted Data function is performed.
- 4 Drive Ready – This bit is asserted if the unit currently selected exists, is properly supplied with power, has a diskette installed properly, has its door closed, and has a diskette up to speed.

NOTE 1

This bit is only valid for either drive when retrieved via a Read Status function or for drive 0 upon completion of an Initialize.

NOTE 2

If the error bit was set in the RX2CS but error bits are not set in the RXES, specific error conditions can be accessed via a read error register function.

4.1.3.7 RX28 – RX Error and Status (Figure 4-10) – The RX2ES contains the current error and status conditions of the selected drive. This read-only register can be accessed by the read status function (101). The RX2ES is also available in the interface register upon completion of any function. The RX2ES is accessed by the XDR instruction. The meaning of the error bits is given below.

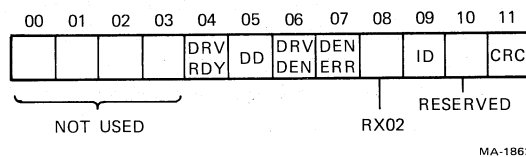

Figure 4-10 RX2ES Format (RX28)

Bit No. Description

- 11 CRC Error – The cyclic redundancy check at the end of the data field has indicated an error. The data must be considered invalid; it is suggested that the data transfer be retried up to 10 times; as most data errors are recoverable (soft).
- 10 Reserved.
- 9 Initialize Done – This bit indicates completion of the Initialize routine. It can be asserted due to RX02 power failure, system power failure, or programmable or bus Initialize. This bit is not available within the RX2ES from a read status function.

Bit No. Description

- 8 RX02 - This bit is asserted if an RX02 system is being used.
- 7 DEN ERR - This bit indicates that the density of the function does not agree with the drive density. Upon detection of this error the control terminates the operation and asserts error and done.
- 6 DRV DEN - This bit indicates the density of the diskette in the drive selected (0 = single, 1 = double).
- 5 Deleted Data (DD) - In the course of reading data, a deleted data mark was detected in the identification field. The data following will be collected and transferred normally, as the deleted data mark has no further significance within the RX02. Any alteration of files or actual deletion of data due to this mark must be accomplished by user software. This bit will be set if a successful or unsuccessful write deleted data function is performed.
- 4 Drive Ready - This bit is asserted if the unit currently selected exists, is properly supplied with power, has a diskette installed properly, has its door closed, and has a diskette up to speed.

NOTE 1

This bit is only valid for either drive when retrieved via a read status function or for drive 0 upon completion of an Initialize.

NOTE 2

If the error bit was set in the RX2CS but error bits are not set in the RX2ES, specific error conditions can be accessed via a read error code function.

4.1.4 Function Code Description

The RX8E/RX28 functions are initiated by means of the Load command described in Paragraphs 4.1.2.1 and 4.1.2.2. The done flag should be tested and cleared with the SDN instruction in order to verify that the RX8E/RX28 is in the Done state prior to issuing the command instruction. Upon receiving a command instruction while in the Done state, the RX8E/RX28 enters the Not Done state while the command is decoded. Each of the eight functions summarized below requires that a strict protocol be followed for the successful transfer of data, status, and address information. The protocol for each function is described in the following sections. A summary table is presented below.

Octal	8	AC		Function
		9	10	
0	0	0	0	Fill Buffer
2	0	0	1	Empty Buffer
4	0	1	0	Write Sector
6	0	1	1	Read Sector
10	1	0	0	Not Used (RX8E), Set Density (RX28)
12	1	0	1	Read Status
14	1	1	0	Write Deleted Data Sector
16	1	1	1	Read Error Register

NOTE

AC bit 11 is assumed to be 0 in the above octal codes since AC bit 11 can be 0 or 1.

4.1.4.1 Fill Buffer (000) – For RX8E this function is used to load the RX02 sector buffer from the host processor with 64 12-bit words if in 12-bit mode or 128 8-bit words if in 8-bit mode. For RX28 this function loads the sector buffer in 12-bit mode with 64 12-bit words for single density or 128 12-bit words for double density; in the 8-bit mode, the buffer is loaded with 128 8-bit bytes for single density or 256 8-bit bytes for double density. This instruction only loads the sector buffer. In order to complete the transfer to the diskette, another function, write sector, must be performed. The buffer may also be read back by means of the empty buffer function in order to verify the data.

Upon decoding the fill buffer function, the RX02 will set the transfer request (TR) flag, signaling a request for the first data word. The TR flag must be tested and cleared by the host processor with the STR instructions prior to each successive XDR IOT (Paragraph 4.1.2.4). The data word can then be transferred to the interface register by means of the XDR IOT. The RX02 next moves the data word from the interface register to the sector buffer and sets the TR flag as a request for the next data word. The sequence above is repeated, until the sector buffer has been loaded (64 data transfers for 12-bit mode or 128 data transfers for 8-bit mode). After the 64th (or 128th) word has been loaded into the sector buffer, the RX2ES is moved to the interface register, and the RX02 sets the done flag to indicate the completion of the function. Therefore, it is unnecessary for the host processor to keep a count of the data transfers. Any XDR commands after Done is set will result in the RX2ES status word being loaded in the AC. The sector buffer must be completely loaded before the RX8E/RX28 will set Done and recognize a new command. An interrupt would now occur if Interrupt Enable were set.

4.1.4.2 Empty Buffer (001) – This function moves the contents of the sector buffer to the host processor. Upon decoding this function RX2ES bits are cleared and the TR flag is set with the first data word in the interface register. This TR flag signifies the request for a data transfer from the RX8E/RX28 to the host processor. The flag must be tested and cleared; then the word can be moved to the AC by an XDR command. The direction of transfer for an XDR command is controlled by the RX02. The TR flag is set again with the next word in the interface register. The above sequence is repeated until all words or bytes have been transferred, thus emptying the sector buffer. The done flag is then set after the RX2ES is moved in the interface register to indicate the end of the function. An interrupt would now occur if Interrupt Enable were set.

NOTE

The empty buffer function does not destroy the contents of the sector buffer.

4.1.4.3 Write Sector (010) – This function transfers the contents of the sector buffer to a specific track and sector on the diskette. Upon decoding this function, the RX8E/RX28 clears the RX2ES and sets the TR flag, signifying a request for the sector address. The TR flag must be tested and cleared before the binary sector address can be loaded into the interface register by means of the XDR command. The sector address must be within the limits 1–32₈.

The TR flag is set, signifying a request for the track address. The TR flag must be tested and cleared; then the binary track address may be loaded into the interface register by means of the XDR command. The track address must be within the limits 0–114₈.

The RX02 tests the supplied track address to determine if it is within the allowable limits. If it is not, the RX2ES is moved to the interface register, the error and done flags are set, and the function is terminated.

If the track address is legal, the RX02 moves the head of the selected drive to the selected track, locates the requested sector, transfers the contents of the sector buffer and a CRC character to that sector, and sets Done. Any errors encountered in the seek operation will cause the function to cease, the RX2ES to be loaded into the interface register, and the error and done flags to be set. If no errors are encountered, the RX2ES is loaded into the interface register and only the done flag is set.

NOTE

The write sector function does not destroy the contents of the sector buffer.

4.1.4.4 Read Sector (011) – This function moves a sector of data from a specified track and sector to the sector buffer. Upon decoding this function, the RX8E/RX28 clears RX2ES and sets the TR flag, signifying the request for the sector address. The flag must be tested and cleared. The sector address is then loaded into the interface register by means of the XDR command. The TR flag is set, signifying a request for the track address. The flag is tested and cleared by the host processor and the track address is then loaded into the interface register by an XDR command. The legality of the track address is checked by the RX02. If illegal, the error and done flags are set with the RX2ES moved to the interface register and the function is terminated. Otherwise, the RX02 moves the head to the specified track, locates the specified sector, transfers the data to the sector buffer, computes and checks CRC for the data. If no errors occur, the done flag is set with the RX2ES in the interface register. If an error occurs anytime during the execution of the function, the function is terminated by setting the error and done flags with RX2ES in the interface register. A detection of CRC error results in RX2ES bit 11 being set. If a deleted data mark was encountered at the beginning of the desired data field, RX2ES bit 5 is set.

4.1.4.5 Set Media Density (100) for RX28 only – This function causes the entire diskette to be reasigned to a new density. The density bit (bit 3 RX2CS) indicates the new density of the diskette. The control reformats the diskette by writing new data address marks (double or single density) and zeroing out all data fields on the diskette. Before executing the command the control will look for a protective key word of 01001001 (ASCII'I').

The control starts at sector 1, track 0 and reads the header information, then starts a write operation, writing the new data address mark and data field as well as CRC characters. If the header information is damaged, the control will abort the operation and assert DONE and ERROR.

This operation takes about 15 seconds and should not be interrupted. If for any reason the operation is interrupted, an illegal diskette has been generated which may have data marks of both densities. This diskette should again be completely reformatted.

4.1.4.6 Maintenance Read Status (101) for RX28 only – This function updates the drive ready and drive density status of the selected drive, clears the INIT DONE bit, updates the Unit Sel, possibly sets the density error bit and leaves the remainder of the RX2ES unchanged. The drive density is updated by loading the head on the selected drive (without changing head and reading position) with the first header and data mark that randomly appears under the head. The control will then generate the appropriate number of shift pulses which will transfer the RX2ES (error and status) register over the interface. Upon completion of the RX2ES transfer, the control asserts Done to complete the operation.

4.1.4.7 Read Status (101) for RX8E only – Upon decoding this function, the RX02 moves the RXES to the RX8E interface register and sets the done flag. The RXES can then be read by the transfer data register (XDR) command. The bits are defined in Paragraph 4.1.3.6.

NOTE

The average time for this function is 250 ms. Excessive use of this function will result in substantially reduced throughput.

4.1.4.8 Write Deleted Data Sector (110) – This function is identical to the write data function except that a deleted data mark is written prior to the data field rather than the normal data mark (Paragraph 4.1.3.2). RX2ES bit 5 (Deleted Data) will be set in the interface register upon completion of the function.

4.1.4.9 Read Error Code Function (111) – The read error code function can be used to retrieve explicit error information upon detection of the error flag. Upon receiving this function, the RX02 moves an error code to the interface register and sets Done. The interface register can then be read via an XDR command and the code interrogated to determine which type of failure occurred (Paragraph 4.1.5).

NOTE

Care should be exercised in the use of this function. The program must perform this function before a read status because the error register is always modified by a read status function.

4.1.4.10 Power Fail – There is no actual function code associated with power fail. When the RX02 senses a loss of power, it will unload the head and abort all controller action. All status signals are invalid while power is low.

When the RX02 senses the return of power, it will remove Done and begin a sequence to:

1. Move drive 1 head position mechanism to track 0.
2. Clear any active error bits.
3. Read sector 1 of track 1 of drive 0 into the buffer.
4. Set Initialize Done bit of the RX2ES, after which Done is again asserted.

There is no guarantee that information being written at the time of a power failure will be retrievable. However, all other information on the diskette will remain unaltered.

INIT IOT is a method of aborting an incomplete function (Paragraph 4.1.2.7).

4.1.5 Error Recovery

4.1.5.1 RX8E – There are two error indications given by the RX8E system. The read status function (Paragraph 4.1.4.7) will assemble the current contents of the RXES (Paragraph 4.1.3.6), which can be sampled to determine errors. The read error register function (Paragraph 4.1.4.9) can also be used to retrieve explicit error information.

The results of the read status function or the read error register function are in the interface register when Done sets, indicating the completion of the function. The XDR IOT must be issued to transfer the contents of the interface register to the PDP-8's AC.

NOTE

A read status function is not necessary if the DRV READY bit is not going to be interrogated because the RXES is in the interface register at the completion of every function.

The error codes for the read error register function are presented below.

Octal Code	Error Code Meaning
0010	Drive 0 failed to see home on Initialize.
0020	Drive 1 failed to see home on Initialize.
0030	Found home when stepping out 10 tracks for INIT
0040	Tried to access a track greater than 77
0050	Home was found before desired track was reached
0070	Desired sector could not be found after looking at 52 headers (2 revolutions)
0110	More than 40 μ s and no SEP clock seen
0120	A preamble could not be found.
0130	Preamble found but no I/O mark found within allowable time span
0150	The header track address of a good header does not compare with the desired track.
0160	Too many tries for an IDAM (identifies header)
0170	Data AM not found in allotted time
0200	CRC error on reading the sector from the disk. No code appears in the ERREG.
0210	All parity errors
0220	Self diagnostic error on Initialize
0240	Density Error

4.1.5.2 RX28 – There are two error indications given by the RX28 system. The read status function will assemble the current contents of the RX2ES which can be sampled to determine errors. The read error register function can also be used to retrieve explicit error information.

The results of the read status function or the read error register function are in the interface register when Done sets, indicating the completion of the function. The XDR IOT must be issued to transfer the contents of the interface register to the PDP-8's AC.

NOTE

A read status function is not necessary if the DRV RDY bit is not going to be interrogated because the RX2ES is in the interface register at the completion of every function.

The error codes for the read error register function are presented below.

Octal Code	Error Code Meaning
0010	Drive 0 failed to see home on Initialize.
0020	Drive 1 failed to see home on Initialize.
0040	Tried to access a track greater than 76
0050	Home was found before desired track was reached.
0070	Desired sector could not be found after looking at 52 headers (2 revolutions).
0110	More than 40 μ s and no SEP clock seen
0120	A preamble could not be found.
0130	Preamble found but no ID mark found within allowable time span
0150	The header track address of a good header does not compare with the desired track.
0160	Too many tries for an IDAM (identifies header)
0170	Data AM not found in allotted time
0200	CRC error on reading the sector from the disk
0220	R/W electronics failed maintenance mode test.
0240	Density error
0250	Wrong key word for Set Media Density command

4.1.6 RX8E Programming Examples

4.1.6.1 Write/Write Deleted Data/Read Functions – Figure 4-11 presents a program for implementing a write, write deleted data, or a read function with interrupts turned off (IOF). The first 3 steps preset the PTRY, CTRY, and STRY retry counters, which are set at 10 retries but can be changed to any number. Starting at RETRY, the program tests for 8- or 12-bit mode, type of function, and drive. Once the command is loaded, the program waits in a loop for the controller to respond with transfer request (TR). When TR is set, the sector address is loaded and the AC is cleared. The program loops while waiting for the controller to respond with another TR. When TR is reset, the track address is loaded and the AC is cleared again. The program loops to wait for the Done condition.

When the done flag is set, the program checks for an error condition, indicated by the error flag being set. If the AC=0000, the error is a seek error; if bit 11 of the AC is set, the error is a CRC error. Error status from the RXES is saved and tested to determine the error (Paragraph 4.1.3.6). The RXES will not include the select drive ready bit. If a parity error is detected, the program increments and tests the PTRY retry counter. If a parity error persists after 10 tries, it is considered a hard error. If 10 retries have not occurred, a branch is made to RETRY and the sequence is repeated.

After a parity test, the program tests to see if the CRC error bit is set. If a CRC error is detected, the program increments and tests the CTRY retry counter. If a CRC error persists after 10 retries, it is considered a hard error. If 10 retries have not occurred, a branch is made to RETRY and the sequence repeated.

A seek error is assumed if neither a CRC nor a parity error is detected. An Initialize (INIT) instruction is performed (Paragraph 4.1.2.8). During a write or write deleted data function, the sector buffer must be refilled because INIT will cause sector 1 of track 1 of drive 0 to be read, which will destroy the previous contents of the sector buffer. The instruction sequence for a fill buffer function is not included in Figure 4-11, but is presented in Figure 4-13. After the system has been initialized, the program increments and tests the STRY retry counter. If a seek error persists after 10 tries, it is considered a hard error. If 10 retries have not occurred, a branch is made to RETRY and the sequence repeated.

4.1.6.2 Empty Buffer Function – Figure 4-12 shows a program for implementing an empty buffer function with interrupts turned off (IOF). The first instruction sets the number of retries at 10. A 2 is set in the AC to indicate an Empty Buffer command and the command is loaded. When TR is set, the program jumps to EMPTY to transfer a word to the BUFFER location. A jump is made back to loop to wait for another TR. This process continues until either 64 words or 128 bytes have been emptied from the sector buffer. When Done is set, the program tests to see if the error bit is set. If the error bit is set, the program retries 10 times. If the error persists, a hard parity error is assumed, indicating a problem in the interface cable.

4.1.6.3 Fill Buffer Function – Figure 4-13 presents a program to implement a fill buffer function. It is very similar to the empty buffer example.

```

1      /PROGRAMMING EXAMPLES FOR THE RX8/RX01 FLEXIBLE DISKETTE
2      /
3      /THE FOLLOWING ARE RX01 IOT CODE DEFINITIONS
4      /
5      /THE STANDARD IOT DEVICE CODE IS 670-
6      /
7      6701   LCD=6701           /IOT TO LOAD THE COMMAND, (AC) IS THE COMMAND
8      6702   XDR=6702          /IOT TO LOAD OR READ THE TRANSFER REGISTER
9      6703   STR=6703          /IOT TO SKIP ON A TRANSFER REQUEST FLAG
10     6704   SER=6704          /IOT TO SKIP ON AN ERROR FLAG
11     6705   SDN=6705          /IOT TO SKIP ON THE DONE FLAG
12     6706   INTR=6706         / (AC) = 0 INTERRUPT ENABLE OFF/ (AC) = 1 MEANS ON
13     6707   INIT=6707         /IOT TO INITIALIZAE THE RX8/RX01 SUBSYSTEM
14     /
15     /THE FOLLOWING IS A PROGRAMMING EXAMPLE OF THE PROTOCOL REQUIRED
16     /
17     /TO WRITE, WRITE DELETED DATA, OR READ AT SECTOR "S" (THE CONTENTS OF PROGRAM
18     /
19     /LOCATION SECTOR) OF TRACK "T" (THE CONTENTS OF PROGRAM LOCATION TRACK)
20     /
21     /IN 8 OR 12 BIT MODE
22     /
23     0200 1254   START,   TAD KM10           / -10
24     0201 3255           DCA PTRY           /PARITY RETRY COUNTER
25     0202 1254           TAD KM10
26     0203 3256           DCA CTRY           /CRC RETRY COUNTER
27     0204 1254           TAD KM10
28     0205 3257           DCA STRY           /SEEK RETRY COUNTER
29     /
30     /WRITE, WRITE DELETED DATA, OR READ
31     /
32     0206 1260   RETRY,   TAD MODE           /0 IF 12-BIT, 100 IF 8-BIT
33     0207 1261           TAD COMMAND        / 4 IF WRITE, 14 IF WRITE DELETED
34     /                                     /DATA, OR 6 IF READ
35     0210 1262           TAD UNIT          / 0 IF UNIT 0, 20 IF UNIT 1
36     0211 6701           LCD              /IOT 67X1 TO LOAD THE COMMAND
37     /
38     /WAIT FOR THE TRANSFER REQUEST FLAG THEN TRANSFER THE SECTOR ADDRESS
39     /
40     0212 6703           STR                /IOT 67X3 TO
41     0213 5212           JMP , -1          /WAIT FOR TRANSFER REQUEST FLAG
42     0214 1263           TAD SECTOR        / 1 TO 32(OCTAL)
43     0215 6702           XDR              /IOT TO LOAD SECTOR
44     0216 7200           CLA              /CLA BECAUSE IOT XDR DOESN'T
45     /
46     /WAIT FOR THE TRANSFER REQUEST FLAG THEN TRANSFER THE TRACK ADDRESS
47     /
48     0217 6703           STR                /IOT 67X3 TO
49     0220 5217           JMP , -1          /WAIT FOR TRANSFER REQUEST
50     0221 1264           TAD TRACK         / 0 TO 14(OCTAL)
51     0222 6702           XDR              /IOT TO LOAD TRACK
52     0223 7200           CLA              /CLA BECAUSE IOT XDR DOESN'T
53     /
54     /THE SECTOR AND TRACK ADDRESSES HAVE BEEN TRANSFERRED TO THE RX01 VIA THE XDR IOT
55     /
56     /WAIT FOR THE DONE FLAG AND CHECK FOR ANY ERRORS
57     /
58     /IF THE FUNCTION HAS COMPLETED SUCCESSFULLY (NO ERROR FLAG) THEN HALT
59     /
60     0224 6705           SDN                /IOT 67X5 TO
61     0225 5224           JMP , -1          /WAIT FOR DONE FLAG
62     0226 6704           SER              /IOT 67X4 SAMPLES ERROR FLAG
63     0227 7402           HLT               / OK = COMPLETED
64     /
65     /THE ERROR FLAG IS SET
66     /
67     /THE CONTENTS OF THE TRANSFER REGISTER IS THE ERROR STATUS
68     /
69     /IF TRANSFER REGISTER BITS 10, AND 11 = 0 THEN SOME TYPE OF SEEK ERROR HAS OCCURED,
70     /IF TRANSFER REGISTER BIT 11 = 1 THEN A CRC ERROR HAS OCCURED,
71     /IF TRANSFER REGISTER BIT 10 = 1 THEN A PARITY ERROR HAS OCCURED
72     /
73     0230 6702           XDR                /GET CONTENTS OF TR (ERROR STATUS)
74     0231 3265           DCA ASTATUS       /AND SAVE
75     0232 7305           CLL CLA IAC RAL   / 2
76     0233 0265           AND ASTATUS      /TEST FOR PARITY ERROR
77     0234 7650           SNA CLA          /SKIP IF PARITY ERROR
78     0235 5241           JMP TCRC         /NOT A PARITY ERROR - MAYBE CRC
79     /
80     /A PARITY ERROR HAS OCCURED
81     /
82     /INCREMENT AND TEST THE PARITY ERROR RETRY COUNTER PROGRAM LOCATION " PTRY "
83     /
84     /AND RETRY THE " COMMAND " UNTIL THE PARITY ERROR RECOVERS
85     /
86     /OR UNTIL THE PTRY COUNTER OVERFLOWS TO 0
87     /
88     0236 2255           ISE PTRY          /RETRY THE COMMAND
89     0237 5206           JMP RETRY         /HARD PARITY ERROR
90     0240 7402           HLT
91     /
92     /THE ERROR FLAG IS SET BUT THE ERROR IS NOT A PARITY ERROR
93     /
94     /TEST FOR A CRC ERROR
95     /
96     0241 7301           TCRC,   CLL CLA IAC / 1
97     0242 4265           AND ASTATUS      /TEST FOR A CRC ERROR
98     0243 7650           SNA CLA          /SKIP IF A CRC ERROR
99     0244 5250           JMP SEEK         /NOT A CRC - MUST BE A SEEK

```

Figure 4-11 RX8E Write/Write Deleted Data/Read Example (Sheet 1 of 2)

```

99          /A CRC ERROR HAS OCCURED
100         /INCREMENT AND TEST THE CRC ERROR RETRY COUNTER PROGRAM LOCATION " CTRY "
101         /
102         /AND RETRY THE COMMAND UNTIL THE CRC ERROR RECOVERS
103         /
104         /OR UNTIL THE CTRY COUNTER OVERFLOWS TO 0
105         /
106         /
107         0245 2256          /ISE CTRY
108         0246 5206          JMP RETRY          /RETRY THE COMMAND
109         0247 7402          HLT          /HARD CRC ERROR
110         /
111         /THE ERROR FLAG IS SET
112         /
113         /THE ERROR IS (NOT) A PARITY ERROR AND IS (NOT) A CRC ERROR
114         /
115         /THEREFORE IS MUST BE A SEEK ERROR
116         /
117         / (CONTENTS OF THE TRANSFER REGISTER BITS 10, AND 11 = 0)
118         /
119         0250 6707          SEEK, INIT          /IOT 67X7 TO INITIATE
120         /
121         /INCREMENT AND TEST THE SEEK ERROR RETRY COUNTER PROGRAM LOCATION " STRY "
122         /
123         /AND RETRY THE COMMAND UNTIL THE SEEK ERROR RECOVERS
124         /
125         /OR UNTIL THE CTRY COUNTER OVERFLOWS TO 0
126         /
127         0251 2257          /ISE STRY
128         0252 5206          JMP RETRY          /RETRY THE COMMAND
129         0253 7402          HLT          /HARD SEEK ERROR
130         /
131         /THE FOLLOWING PROGRAM LOCATIONS ARE REFERENCED WITHIN THIS EXAMPLE
132         /
133         0254 7770          KM10, -10
134         /
135         /THE FOLLOWING 3 PROGRAM LOCATIONS ARE THE ERROR RETRY COUNTERS
136         0255 0000          PTRY, 0          /PARITY ERROR RETRY COUNTER
137         0256 0000          CTRY, 0          /CRC ERROR RETRY COUNTER
138         0257 0000          STRY, 0          /SEEK ERROR RETRY COUNTER
139         /
140         /PROGRAM LOCATION " MODE " CONTAINS A 0 IF 12-BIT MODE, OR
141         /CONTAINS A 100 IF 8-BIT MODE
142         /
143         0260 0000          MODE, 0          / 0 OR 100
144         /
145         /PROGRAM LOCATION " COMMAND " CONTAINS THE COMMAND TO BE ISSUED VIA THE LCD IOT
146         /WRITE (4), WRITE DELETED DATA (14), OR READ (6), OR EMPTY BUFFER (2)
147         /
148         0261 0000          COMMAND, 0          / 4, 14, OR 6, OR 2
149         /
150         /PROGRAM LOCATION " UNIT " CONTAINS THE UNIT DESIGNATION
151         /
152         /UNIT 0 (0), OR UNIT 1 (20)
153         /
154         0262 0000          UNIT, 0          / 0, OR 20
155         /
156         /PROGRAM LOCATION " SECTOR " CONTAINS THE SECTOR ADDRESS (1 TO 32 OCTAL)
157         /
158         0263 0000          SECTOR, 0          / 1 TO 32 OCTAL
159         /
160         /PROGRAM LOCATION " TRACK " CONTAINS THE TRACK ADDRESS (0 TO 114 OCTAL)
161         /
162         0264 0000          TRACK, 0          / 0 TO 114 OCTAL
163         /
164         /PROGRAM LOCATION " ASTATUS " CONTAINS THE CONTENTS OF THE TRANSFER REGISTER
165         /
166         /AT THE DETECTION OF AN ERROR (ERROR FLAG = 1) WHICH CORRESPONDS TO THE
167         /ERROR STATUS
168         /
169         / = 0 IF SEEK ERROR, 1 IF CRC ERROR, 2 IF PARITY ERROR
170         /
171         0265 0000          ASTATUS, 0          /STATUS AT ERROR
172         /
173         /

```

Figure 4-11 RX8E Write/Write Deleted Data/Read Example (Sheet 2 of 2)

```

228      /THE FOLLOWING IS A PROGRAMMING EXAMPLE OF PROTOCOL REQUIRED TO
229      /
230      /EMPTY THE SECTOR BUFFER OF 64 12-BIT WORDS (12 BIT MODE), OR
231      /
232      /EMPTY THE SECTOR BUFFER OF 128 8-BIT BYTES (8 BIT MODE)
233      /
234      0312 1254      EENTRY, TAD KH10          / 8 TRYS TO EMPTY THE SECTOR BUFFER
235      0313 3255          DCA PTRY          /PARITY ERROR RETRY COUNTER
236      0314 1377      ESETUP, TAD (BUFFER-1) /PROGRAMS DATA BUFFER
237      0315 3010          DCA A10          /AUTO INDEX REGISTER 10
238      0316 1260          TAD MODE         / 0 IF 12-BIT, 100 IF 8 BIT
239      0317 1261          TAD COMMAND      / 2 MEANS EMPTY BUFFER
240      0320 6701          LCD              /IOT TO ISSUE THE COMMAND
241      /
242      /WAIT FOR A TRANSFER REQUEST FLAG BEFORE TRANSFERRING DATA TO THE PROGRAMS
243      /
244      /DATA BUFFER FROM THE RX01 SECTOR BUFFER
245      /
246      /WAIT FOR A DONE FLAG TO INDICATE THE COMPLETION OF THE EMPTY BUFFER COMMAND PRIOR TO
247      /
248      /TESTING THE ERROR FLAG
249      /
250      0321 6703      ELOOP, STR          /TEST FOR TR FLAG
251      0322 7410          SKP            /TR NOT SET, TEST FOR DONE FLAG
252      0323 5333          JMP EMPTY      /TR FLAG SET
253      0324 6705          SDN            /TEST FOR DONE FLAG
254      0325 5274          JMP ELOOP      /NOT TR, OR DONE YET
255      /
256      /THE DONE FLAG IS SET
257      /
258      /TEST FOR ANY ERRORS (ONLY ERROR POSSIBLE IS A PARITY ERROR)
259      /
260      0326 6704          SER            /TEST FOR THE ERROR FLAG
261      0327 7402          HLT            /NO ERRORS - OK
262      /
263      /INCREMENT AND TEST THE PARITY ERROR RETRY PROGRAM LOCATION " PTRY "
264      /
265      /AND RETRY THE COMMAND UNTIL THE ERROR RECOVERS
266      /
267      /OR UNTIL THE PTRY COUNTER OVERFLOWS TO 0
268      /
269      0330 2255          ISZ PTRY
270      0331 5314          JMP ESETUP      /RETRY TO EMPTY THE SECTOR BUFFER
271      0332 7402          HLT            /HARD PARITY ERROR
272      /
273      /THE TRANSFER REQUEST FLAG IS SET
274      /
275      /TRANSFER DATA TO THE PROGRAMS DATA BUFFER FROM THE RX01 SECTOR BUFFER
276      /
277      0333 6702      EMPTY, XDR          /FROM THE RX01 SECTOR BUFFER
278      0334 3410          DCA I A10      /TO THE PROGRAMS DATA BUFFER
279      0335 5321          JMP ELOOP      /LOOP UNTIL THE DONE FLAG SETS
280      0377 0377          PAGE
281      /
282      /THE FOLLOWING PROGRAM LOCATIONS ARE RESERVED FOR THE PROGRAMS DATA BUFFER
283      /
284      0400 0000      BUFFER, 0
285      0600          *BUFFER+200
286      S

```

Figure 4-12 RX8E Empty Buffer Example

```

174          /THE FOLLOWING IS A PROGRAMMING EXAMPLE OF PROTOCOL REQUIRED TO
175          /
176          /FILL THE SECTOR BUFFER WITH 64 12-BIT WORDS (12 BIT MODE), OR
177          /
178          /FILL THE SECTOR BUFFER WITH 128 8-BIT BYTES (8 BIT MODE)
179          /
180          0010      A10=10
181          /
182          0266 1254      FENTRY, TAD KH10          / 8 TRYS TO FILL THE SECTOR BUFFER
183          0267 3255          DCA PTRY          /PARITY ERROR RETRY COUNTER
184          0270 1377      SETUP, TAD (BUFFER-1)    /PROGRAMS DATA BUFFER
185          0271 3010          DCA A10          /AUTO INDEX REGISTER 10
186          0272 1260          TAD MODE          / 0 IF 12-BIT, 100 IF 8 BIT
187          0273 6701          LCD          /IOT TO ISSUE THE COMMAND
188          /
189          /WAIT FOR A TRANSFER REQUEST FLAG BEFORE TRANSFERRING DATA FROM THE PROGRAMS
190          /
191          /DATA BUFFER TO THE RX01 SECTOR BUFFER
192          /
193          /WAIT FOR A DONE FLAG TO INDICATE THE COMPLETION OF THE FILL BUFFER COMMAND PRIOR TO
194          /
195          /TESTING THE ERROR FLAG
196          /
197          0274 6703      LOOP, STR          /TEST FOR TR FLAG
198          0275 7410          SKP          /TR NOT SET, TEST FOR DONE FLAG
199          0276 5306          JMP FILL          /TR FLAG SET
200          0277 6705          SDN          /TEST FOR DONE FLAG
201          0300 5274          JMP LOOP          /NOT TR, OR DONE YET
202          /
203          /THE DONE FLAG IS SET
204          /
205          /TEST FOR ANY ERRORS (ONLY ERROR POSSIBLE IS A PARITY ERROR)
206          /
207          0301 6704          SER          /TEST FOR THE ERROR FLAG
208          0302 7402          HLT          /NO ERRORS - OK
209          /
210          /INCREMENT AND TEST THE PARITY ERROR RETRY PROGRAM LOCATION " PTRY "
211          /
212          /AND RETRY THE COMMAND UNTIL THE ERROR RECOVERS
213          /
214          /OR UNTIL THE PTRY COUNTER OVERFLOWS TO 0
215          /
216          0303 2255          ISZ PTRY
217          0304 5270          JMP SETUP          /RETRY TO FILL THE SECTOR BUFFER
218          0305 7402          HLT          /HARD PARITY ERROR
219          /
220          /THE TRANSFER REQUEST FLAG IS SET
221          /
222          /TRANSFER DATA FROM THE PROGRAMS DATA BUFFER TO THE RX01 SECTOR BUFFER
223          /
224          0306 1410      FILL, TAD I A10          /VIA AUTO INDEX REGISTER 10
225          0307 6702          XDR          /TO THE RX01 SECTOR BUFFER
226          0310 7200          CLA          /CLA BECAUSE IOT XDR DOESN'T
227          0311 5274          JMP LOOP          /LOOP UNTIL THE DONE FLAG SETS

```

Figure 4-13 RX8E Fill Buffer Example

4.1.7 RX28 Programming Examples

Figures 4-14, 4-15, and 4-16 are programming examples for write, write deleted data or read functions, for fill buffer functions, and for empty buffer functions, respectively. These examples are very similar to the RX8E programming examples described in Paragraph 4.1.6. Basically, there are two differences between the RX8E and RX28 examples. First, for the RX28 when a command is transferred in the 8-bit mode of operation, it is transferred in two 8-bit words using an XDR to transfer the second command word (see location 0225 in Figure 4-14); second, for the RX28, there is no parity error check as there is in the RX8E; instead there is a density error check.

```

1 /PROGRAMING EXAMPLES FOR THE RX28/E FLEXIBLE DISKETTE
2 /
3 /THE FOLLOWING ARE RX01 IOT CODE DEFINITIONS
4 /
5 /THE STANDARD IOT DEVICE CODE IS 675-
6 /
7 6701 LCD# 6701 /IOT TO LOAD THE COMMAND, (AC) IS THE COMMAND
8 6702 XDR# 6702 /IOT TO LOAD OR HEAD THE TRANSFER REGISTER
9 6703 STR# 6703 /IOT TO SKIP ON TRANSFER REQUEST FLAG
10 6704 SER# 6704 /IOT TO SKIP ON ERROR FLAG
11 6705 SDN# 6705 /IOT TO SKIP ON DONE FLAG
12 6706 TNTR# 6706 /((AC)#0 INTERRUPT ENABLE OFF/((AC)#1 MEANS ON
13 6707 TNIT# 6707 /IOT TO INITIALIZE THE RX SUBSYSTEM
14 /
15 /THE FOLLOWING IS A PROGRAMING EXAMPLE OF THE PROTOCOL REQUIRED
16 /
17 /TO WRITE, WRITE DELETED DATA, OR READ AT SECTOR "S" (THE CONTENTS OF PROGRAM
18 /LOCATION "SECTOR") OF TRACK "T" (THE CONTENTS OF PROGRAM LOCATION
19 /"TRACK") IN 8 OR 12 BIT MODE.
20 /
21 *200
22 0200 0200 *200
23 0201 1200 START, TAD K410 /GET RETRY CONSTANT
24 0202 3271 DCA CTRY /SET UP CRC RETRY COUNT
25 0203 1200 TAD K410 /SET UP SEEK RETRY COUNT
26 0204 3271 DCA STRY
27 /
28 /WRITE, WRITE DELETED DATA, OR READ
29 /
30 /MAKE SURE DRIVE READY FOR US
31 0204 6705 SDN /IF NOT WAIT
32 0205 5204 JMP ==1 /0 IF 12-BIT MODE, 100 IF 8-BIT MODE
33 0206 1273 RETRY, TAD MODE /GET FUNCTION CODE
34 0207 1274 TAD FUNCUN /GET DRIVE PARAMETERS; UNIT, #,
35 0210 1275 TAD DRIVEP /DENSITY
36 /SAVE ENTIRE COMMAND
37 0211 3276 DCA COMMAND /GET COMMAND
38 0212 1276 TAD COMMAND /LOAD COMMAND REGISTER
39 0213 6701 LCD /GET COMMAND
40 0214 1276 TAD COMMAND /WAS IT 8-BIT MODE
41 0215 0207 AND K100 /IF YES SKIP AND DO 8-BIT PROTOCOL
42 0216 7452 SNA /IF 12-BIT DONE LCD PROTOCOL
43 0217 5226 JMP WAITTR /GET UPPER 4 BITS OF
44 0220 7106 CLL RTL /COMMAND WORD TO LOWER
45 0221 7106 RTL /4 BITS OF AC
46 0222 7104 RAL /WAIT FOR A TRANSFER REQUEST
47 0223 6703 STR /LOOP UNTIL TR.
48 0224 5223 JMP ==1 /GIVE SECOND COMMAND WORD
49 0225 6702 XDR
50 /
51 /WAIT FOR TRANSFER REQUEST FLAG THEN TRANSFER SECTOR ADDRESS
52 /
53 0226 6703 WAITTR, STR /IOT TO SKIP ON TRANSFER REQUEST
54 0227 5226 JMP ==1 /LOOP UNTIL TR.
55 0230 1277 TAD SECTOR /1 TO 32 (OCTAL)
56 0231 6702 XDR /LOAD THE SECTOR
57 0232 7202 CLA /CLEAR AC
58 /
59 /WAIT FOR TRANSFER REQUEST FLAG THEN TRANSFER TRACK ADDRESS
60 /
61 0233 6703 STR /SKIP ON TRANSFER REQUEST
62 0234 5233 JMP ==1 /LOOP UNTIL TR
63 0235 1300 TAD TRACK /2 TO 114 (OCTAL)
64 0236 6702 XDR /LOAD THE TRACK
65 0237 7202 CLA /CLEAR AC
66 /
67 /THE COMMAND PROTOCOL HAS BEEN COMPLETED. NOW
68 /
69 /WAIT FOR DONE AND CHECK FOR ERRORS
70 /
71 0240 6705 SDN /IOT TO SKIP ON DONE FLAG
72 0241 5242 JMP ==1 /LOOP UNTIL DONE
73 0242 6704 SER /IOT TO SKIP ON ERROR FLAG
74 0243 7402 HLT /NO ERRORS SO HALT
75 /
76 /THE ERROR FLAG IS SET
77 /
78 /THE ERROR STATUS IS LOCATED IN THE TRANSFER REGISTER
79 /
80 /IF STATUS = 1 THEN CRC ERROR OCCURED
81 /IF STATUS = 20 THEN DENSITY ERROR OCCURED
82 /IF STATUS = 0 THEN SEEK ERROR OCCURED
83 /
84 0244 6702 XDR /GET CONTENTS OF TRANSFER REGISTER
85 /STATUS AT DONE
86 0245 3301 DCA ASTATUS /AND SAVE IT
87 0246 7201 IAC /MASK FOR CRC ERROR BIT
88 0247 0301 AND ASTATUS /IF AC NOT EQUAL TO ZERO CRC
89 0250 7452 SNA CLA /ERROR OCCURED SO SKIP
90 0251 5255 JMP DENSIT /IF AC = 0 THEN CHECK FOR DENSITY ERROR
91 0252 2270 ISZ CTRY /KEEP COUNT OF RETRIES IF = 12 THEN SKIP
92 0253 5206 JMP RETRY /IF RETRIES <10 THEN DO IT AGAIN
93 0254 7402 HLT /HALT
94

```

MA-1071

Figure 4-14 RX28 Write/Write Deleted Data/Read Example
(Sheet 2 of 2)

```

95 /THE ERROR WAS NOT A CRC SO CHECK FOR WRONG DENSITY, IF DENSITY ERROR
96 /DOES EXIST THEN HALT. IF THIS ERROR OCCURS IT COULD JUST HAVE
97 /
98 /BEEN BECAUSE WE FORGOT TO SET THE RIGHT DENSITY IN THE COMMAND WORD
99 /
100 /OR IT COULD BE THE WRONG DISKETTE HAS BEEN INSERTED IN THE DRIVE OR
101 /
102 /IT COULD BE SOME OTHER REASON BUT WE SHOULD KNOW WHAT CAUSED IT
103 /
104 /BEFORE WE PROCEED.
105 /
106 /
107 /
108 0255 7307 DENSIT, CLA CLL IAC RTL /AC = 4
109 0256 7312 RTR /AC = 20, MASK FOR DENSITY ERROR
110 0257 0301 AND ASTATUS /IN STATUS WORD IF SET SKIP
111 0260 7440 SZA /IF NOT DENSITY ERROR MUST BE SEEK ERROR
112 0251 7402 HLT /HALT WITH DENSITY ERROR BIT SET IN AC
113 /
114 /THE ERROR MUST HAVE BEEN A SEEK ERROR IF WE GOT THIS FAR.
115 /
116 /ISSUE AN INITIALIZE TO DRIVE SO WE START FROM TRACK 0
117 /
118 /AND TRY AGAIN
119 /
120 0262 6727 SEEK, INIT /IOT TO INITIALIZE RX
121 0263 0271 ISZ STRY /KEEP COUNT OF SEEK ERRORS
122 0264 5206 JMP RETRY /RETRY COMMAND 10 TIMES
123 0265 7402 HLT /THEN HALT
124 /
125 /CONSTANTS USED BY THIS CODE
126 /
127 0266 7770 KM10, -10
128 0267 0100 K100, 100
129 /
130 /ERROR RETRY COUNTERS
131 /
132 0270 0000 CTRY, 0 /CRC ERROR RETRY COUNTER
133 0271 0000 STRY, 0 /SEEK ERROR RETRY COUNTER
134 0272 0000 ETRY, 0 /FILL AND EMPTY BUFFER RETRY COUNTER
135 /
136 /PROGRAM LOCATION "MODE" CONTAINS 0 IF 12-BIT MODE, OR 100 IF 8-BIT MODE
137 /
138 0273 0000 MODE, 0
139 /
140 /LOCATION "FUNCUN" CONTAINS 4 IF WRITE, 14 IF WRITE DELETED DATA, OR
141 /6 IF READ FUNCTION
142 /
143 0274 0000 FUNCUN, 0
144 /
145 /LOCATION "DRIVEP" HAS BIT ASSIGNMENTS
146 /
147 / 0# JNIT 0 SINGLE DENSITY
148 / 20# JNIT 1 SINGLE DENSITY
149 / 400# JNIT 0 DOUBLE DENSITY
150 / 420# JNIT 1 DOUBLE DENSITY
151 /
152 0275 0000 DRIVEP, 0
153 /
154 /LOCATION "COMMAND" IS WHERE THE ASSEMBLED COMMAND IS STORED
155 /
156 0276 0000 COMMAND, 0
157 /
158 /LOCATION "SECTOR" MUST BE 1 TO 32 OCTAL
159 /
160 0277 0000 SECTOR, 0
161 /
162 /LOCATION "TRACK" MUST BE 0 TO 114 OCTAL
163 /
164 0300 0000 TRACK, 0
165 /
166 /LOCATION "ASTATUS" IS USED TO STORE THE CONTENTS OF THE STATUS
167 /REGISTER IF AN ERROR OCCURS. THE STATUS IS IN THE TRANSFER
168 /REGISTER WHEN "DONE" IS SET.
169 /
170 0301 0000 ASTATUS, 0

```

MA-1872

Figure 4-14 RX28 Write/Write Deleted Data/Read Example
(Sheet 2 of 2)

```

171
172
173
174
175
176
177
178
179
180
181
182
183
184
185
186
187
188
189
190
191
192
193
194
195
196
197
198
199
200
201
202
203
204
205
206
207
208
209
210
211
212
213
214
215
216
217
218
219
220
221
222
223
224
225
226
227
228
229
230
231
232
233
234
235
236
237

```

```

/ THE FOLLOWING IS A PROGRAMMING EXAMPLE FO PROTOCOL REQUIRED TO
/
/ FILL THE SECTOR BUFFER
A10=10
/
FENTRY, TAD KM10 / 8 TRYS TO FILL THE SECTOR BUFFER
DCA ETRY /ERROR RETRY COUNTER
SETUP, TAD (BUFFER-1) /PROGRAMS DATA BUFFER
DCA A10 /AJTD INDEX REGISTER 10
TAD MODE /0 IF 12-BIT, 100 IF 8 BIT
TAD DRIVEP /GET DENSITY
DCA COMMAND /STORE ASSEMBLED COMMAND
TAD COMMAND /GET COMMAND TO AC
LCD /ISSUE COMMAND TO RX
TAD COMMAND /GET SAVED COMMAND
AND K100 /MASK FOR 8-BIT MODE
SNA CLA /IF 8-BIT MODE SET DO 8-MODE PROTOCOL
JMP LOOP /IF 12-BIT MODE GO STRAIGHT TO FILL LOOP
TAD COMMAND /GET SAVED COMMAND WORD
CLL RTL /GET 4 MSB'S (BITS 0,1,2,3) OF
RTL /COMMAND WORD DOWN TO THE
RAL /4 LSB'S (BITS 8,9,10,11) OF AC
STR /TJT TO SKIP ON TRANSFER READY
JMP ...1 /IF TR NOT SET LOOP UNTIL IT DOES
XDR /ISSUE SECOND COMMAND WORD
CLA /CLEAR THE AC AND DO FILL LOOP
/
/ WAIT FOR A TRANSFER REQUEST FLAG BEFORE TRANSFERRING DATA FROM THE PROGRAMS
/
/ DATA BUFFER TO THE RX01 SECTOR BUFFER
/
/ WAIT FOR A DONE FLAG TO INDICATE THE COMPLETION OF THE FILL BUFFER COMMAND PRIOR TO
/
/ TESTING THE ERROR FLAG
/
LOOP, STR /TEST FOR TR FLAG
SKP /TR NOT SET, TEST FOR DONE FLAG
JMP FILL /TR FLAG SET
SDN /TEST FOR DONE FLAG
JMP LOOP /NOT TR, OR DONE YET
/
/ THE DONE FLAG IS SET
/
/ TEST FOR ANY ERRORS
/
SER /TEST FOR THE ERROR FLAG
HLT /NO ERRORS = OK
/
/ INCREMENT AND TEST THE ERROR RETRY PROGRAM LOCATION "ETRY"
/
/ AND RETRY THE COMMAND UNTIL THE ERROR RECOVERS
/
/ OR UNTIL THE ETRY COUNTER OVERFLOWS TO 0
/
ISZ ETRY
JMP SETUP /RETRY TO FILL THE SECTOR BUFFER
HLT /HARD PARITY ERROR
/
/ THE TRANSFER REQUEST FLAG IS SET
/
/ TRANSFER DATA FROM THE PROGRAMS DATA BUFFER TO THE RX01 SECTOR BUFFER
/
FILL, TAD I A10 /VIA AUTO INDEX REGISTER 10
XDR /TO THE RX01 SECTOR BUFFER
CLA /CLA BECAUSE 101 XDR DOESN'T
JMP LOOP /LOOP UNTIL THE DONE FLAG SETS

```

MA-1073

Figure 4-15 RX28 Fill Buffer Example

```

238 /THE FOLLOWING IS A PROGRAMMING EXAMPLE OF PROTOCOL REQUIRED TO
239 /
240 /EMPTY THE SECTOR BUFFER
241 0395 1266 EENTRY, TAD KM10 / 8 TRYS TO EMPTY THE SECTOR BUFFER
242 0396 3272 DCA ETRY /ERROR RETRY COUNTER
243 0397 1377 ESETJP, TAD (BUFFER-1) /PROGRAMS DATA BUFFER
244 0350 3210 DCA A10 /AUTO INDEX REGISTER 10
245 0351 1273 TAD MODE / 0 IF 12-BIT, 100 IF 8 BIT
246 0352 1274 TAD FUNCJN / 2 MEANS EMPTY BUFFER
247 0353 1275 TAD DRIVEP /GET DENSITY
248 0354 3276 DCA COMMAND /STORE ASSEMBLED COMMAND
249 0355 1276 TAD COMMAND /GET COMMAND TO AC
250 0356 6701 LCD /ISSUE COMMAND TO RX
251 0357 1276 TAD COMMAND /GET SAVED COMMAND
252 0360 0267 AND K100 /MASK FOR 8-BIT MODE
253 0361 7650 SNA CLA /IF 8-BIT MODE SET DO 8-MODE PROTOCOL
254 0362 5776* JMP ELOOP /IF 12-BIT MODE GO STRAIGHT TO EMPTY LOOP
255 0363 1276 TAD COMMAND /GET SAVED COMMAND WORD
256 0364 7106 CLL RTL /GET 4 MSB'S (BITS 0,1,2,3) OF
257 0365 7206 RTL /COMMAND WORD DOWN TO THE
258 0366 7204 RAL /4 LSB'S (BITS 8,9,10,11) OF AC
259 0367 6703 STR /IDT TO SKIP ON TRANSFER READY
260 0370 5367 JMP .-1 /IF TR NOT SET LOOP UNTIL IT DOES
261 0371 6702 XDR /ISSUE SECOND COMMAND WORD
262 0372 7200 CLA /CLEAR THE AC AND DO EMPTY LOOP
263 0373 5776* JMP ELOOP /GET OVER TO NEXT PAGE
264 0376 0400
265 0377 0577

PAGE
266 /
267 /WAIT FOR A TRANSFER REQUEST FLAG BEFORE TRANSFERRING DATA TO THE PROGRAMS
268 /
269 /DATA BUFFER FROM THE RX01 SECTOR BUFFER
270 /
271 /WAIT FOR A DONE FLAG TO INDICATE THE COMPLETION OF THE EMPTY BUFFER COMMAND PRIOR TO
272 /
273 /TESTING THE ERROR FLAG
274 /
275 0400 6703 ELOOP, STR /TEST FOR TR FLAG
276 0401 7410 SKP /TR NOT SET, TEST FOR DONE FLAG
277 0402 5212 JMP EMPTY /TR FLAG SET
278 0403 6705 SON /TEST FOR DONE FLAG
279 0404 5200 JMP ELOOP /NOT TR, OR DONE YET

/
280 /THE DONE FLAG IS SET
281 /
282 /
283 /TEST FOR ANY ERRORS
284 /
285 0405 6704 SER /TEST FOR THE ERROR FLAG
286 0406 7402 HLT /NO ERRORS = 0K
287 /
288 /INCREMENT AND TEST THE ERROR RETRY PROGRAM LOCATION "ETRY"
289 /
290 /AND RETRY THE COMMAND UNTIL THE ERROR RECOVERS
291 /
292 /OR UNTIL THE ETRY COUNTER OVERFLOWS TO 0
293 /
294 0407 2777* ISZ ETRY /RETRY TO EMPTY THE SECTOR BUFFER
295 0410 5776* JMP ESETJP /HARD ERROR
296 0411 7402 HLT
297 /
298 /THE TRANSFER REQUEST FLAG IS SET
299 /
300 /TRANSFER DATA TO THE PROGRAMS DATA BUFFER FROM THE RX01 SECTOR BUFFER
301 /
302 0412 6702 EMPTY, XDR /FROM THE RX01 SECTOR BUFFER
303 0413 3410 DCA I A10 /TO THE PROGRAMS DATA BUFFER
304 0414 5200 JMP ELOOP /LOOP UNTIL THE DONE FLAG SETS
305 /
306 0576 0347
307 0577 0272
308 0600 PAGE
309 /THE FOLLOWING PROGRAM LOCATIONS ARE RESERVED FOR THE PROGRAMS DATA BUFFER
310 /
311 BUFFER, 0
312 *BUFFER+400
$

```

MA-1874

Figure 4-16 RX28 Empty Buffer Example

4.1.8 Restrictions and Programming Pitfalls

A set of 11 restrictions and programming pitfalls for the RX8E is presented below.

1. When performing the following sequence of instructions, interrupts must be off.

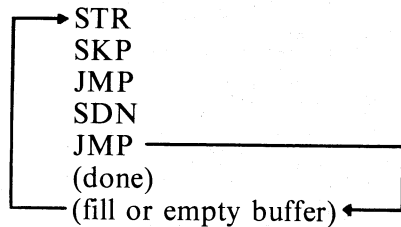

If interrupts are not off, the following sequence of events will occur. Assume interrupts are enabled and the RX8E issues an interrupt request just before the SDN instruction; the SDN instruction will be executed as the last legal instruction before the processor takes over. However, since the done flag is cleared by the SDN instruction, the processor will not find the device that issued the interrupt.

2. The program must issue an SER instruction to test for errors following an SDN instruction.
3. For maximum data throughput for consecutive writes or reads in 8-bit mode, interleave every three sectors; in 12-bit mode, interleave every two sectors. (This of course depends on program overhead.)
4. When issuing the IOT XDR at the end of a function to test the status, the instruction AND 377 must be given because the most significant bits (0-3) contain part of the previous command word.
5. If an error occurs and the program executes a read error register function (111) (Paragraph 4.1.4.9), a parity error may occur for that command. The error code coming back would not be for the original error in which the read error register function was issued, but for the parity error resulting from the read error register function. Therefore, check for parity error with the read status function (101) before checking for errors with the read error register function (111).
6. The SEL DRV RDY bit is present only at the time of the read status function (101) for either drive, or at completion of an Initialize for drive 0.
7. It is not necessary to load the drive select bit into the command word when the command is Fill Buffer (000) or Empty Buffer (001).
8. Sector Addressing: 1-26 or 1-32₈ (No sector 0)
Track Addressing: 0-76 or 1-114₈
9. If a read error register function (111) is desired, the program must perform this function before a read status function (101), because the content of the error register is always modified by a read status function.

10. The instructions STR, SDN, SER also clear the respective flags after testing so that the software must store these flags if future reference to them is needed after performing one of these instructions.
11. Excessive use of the read status function (101) will result in drastically decreased throughput because a read status function requires between one and two diskette revolutions or about 250 ms to complete.

4.2 RX11 AND RXV11 PROGRAMMING INFORMATION

This section describes device registers, register and vector address assignments, programming specifications, and programming examples for the RX11 and RXV11 interfaces.

All software control of the RX11/RXV11 is performed by means of two device registers: the command and status (RXCS) register and a multipurpose data buffer (RXDB) register. These registers have been assigned bus addresses (Paragraph 4.2.1) and can be read or loaded, with certain exceptions, using any instruction referring to their addresses.

The RX02, which includes the mechanical drive(s), read/write electronics, and μ CPU controller, contains all the control circuitry required for implied seeks, automatic head position verification, and calculation and verification of the CRC; it has a buffer large enough to hold one full sector of diskette data (128 8-bit bytes). Information is serially passed between the interface and the RX02.

A typical diskette write sequence, which is initiated by a user program, would occur in two steps:

1. Fill Buffer – A command to fill the buffer is moved into the RXCS. The Go bit (Paragraph 4.2.2.1) must be set. The program tests for transfer request (TR). When TR is detected, the program moves the first of 128 bytes of data to the RXDB. TR goes false while the byte is moved into the RX02. The program retests TR and moves another byte of data when TR is true. When the RX02 sector buffer is full, the Done bit will set, and an interrupt will occur if the program has enabled interrupts.
2. Write Sector – A command to write the contents of the buffer onto the disk is issued to the RXCS. Again the Go bit must be set. The program tests TR, and when TR is true, the program moves the desired sector address to the RXDB. TR goes false while the RX02 handles the sector address. The program again waits for TR and moves the desired track address to the RXDB, and again TR is negated. The RX02 locates the desired track and sector, verifies its location, and writes the contents of the sector buffer onto the diskette. When this is done, an interrupt will occur if the program has enabled interrupts.

A typical diskette read occurs in just the reverse way: first locating and reading a sector into the buffer (read sector) and then unloading the buffer into core (empty buffer). In either case, the content of the buffer is not valid if Power Fail or Initialize follows a fill buffer or read sector function.

4.2.1 Register and Vector Addresses

The RXCS register is normally assigned Unibus address 177170 and the RXDB register is assigned Unibus address 177172. The normal BR priority level is 5, but it can be changed by insertion of a different priority plug located on the interface module. The vector address is 264.

4.2.2 Register Description

4.2.2.1 RXCS – Command and Status (177170) – Loading this register while the RX02 is not busy and with bit 0=1 will initiate a function as described below and indicated in Figure 4-17. Bits 0–4 are write-only bits.

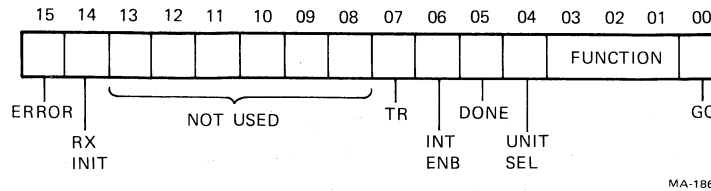

Figure 4-17 RXCS Format (RX11, RXV11)

Bit No. Description

- 0 Go – Initiates a command to RX02. This is a write-only bit.
- 1–3 Function Select – These bits code one of the eight possible functions listed below and described in Paragraph 4.2.3. These are write-only bits.

Code	Function
000	Fill Buffer
001	Empty Buffer
010	Write Sector
011	Read Sector
100	Not used
101	Read Status
110	Write Deleted Data Sector
111	Read Error Register

- 4 Unit select – This bit selects one of the two possible disks for execution of the desired function. This is a write-only bit.
- 5 Done – This bit indicates the completion of a function. Done will generate an interrupt when asserted if Interrupt Enable (RX2CS bit 6) is set. This is a read-only bit.
- 6 Interrupt Enable – This bit is set by the program to enable an interrupt when the RX02 has completed an operation (Done). The condition of this bit is normally determined at the time a function is initiated. This bit is cleared by Initialize and is a read/write bit.
- 7 Transfer Request – This bit signifies that the RX11 or RXV11 needs data or has data available. This is a read-only bit.
- 8–13 Unused
- 14 RX Initialize – This bit is set by the program to initialize the RX11 or RXV11 without initializing all devices on the Unibus. This is a write-only bit.

CAUTION

Loading the lower byte of the RXCS will also load the upper byte of the RXCS.

Upon setting this bit in the RXCS, the RX11 or RXV11 will negate Done and move the head position mechanism of drive 1 (if two are available) to track 0. Upon completion of a successful Initialize, the RX02 will zero the error and status register, set Initialize Done, and set RXES bit 7 (DRV RDY) if unit 0 is ready. It will also read sector 1 of track 1 on drive 0.

- 15 Error - This bit is set by the RX02 to indicate that an error has occurred during an attempt to execute a command. This read-only bit is cleared by the initiation of a new command or an Initialize (Paragraph 4.2.6).

4.2.2.2 RXDB - Data Buffer Register (177172) - This register serves as a general purpose data path between the RX02 and the interface. It may represent one of four RX02 registers according to the protocol of the function in progress (Paragraph 4.2.3).

This register is read/write if the RX02 is not in the process of executing a command; that is, it may be manipulated without affecting the RX02 subsystem. If the RX02 is actively executing a command, this register will only accept data if RXCS bit 7 (TR) is set. In addition, valid data can only be read when TR is set.

CAUTION
**Violation of protocol in manipulation of this register
 may cause permanent data loss.**

4.2.2.3 RXTA - RX Track Address (Figure 4-18) - This register is loaded to indicate on which of the 77 (114₈) tracks a given function is to operate. It can be addressed only under the protocol of the function in progress (Paragraph 4.2.3). Bits 8-15 are unused and are ignored by the control.

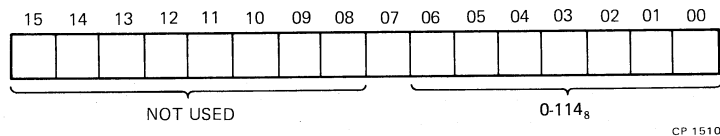

Figure 4-18 RXTA Format (RX11/RXV11)

4.2.2.4 RXSA - RX Sector Address (Figure 4-19) - This register is loaded to indicate on which of the 26 (32₈) sectors a given function is to operate. It can be addressed only under the protocol of the function in progress (Paragraph 4.2.3). Bits 8-15 are unused and are ignored by the control.

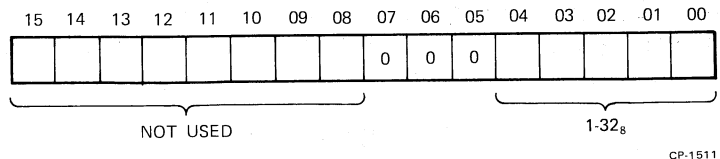

Figure 4-19 RXSA Format (RX11/RXV11)

4.2.2.5 RXDB - RX Data Buffer (Figure 4-20) - All information transferred to and from the floppy media passes through this register and is addressable only under the protocol of the function in progress (Paragraph 4.2.3).

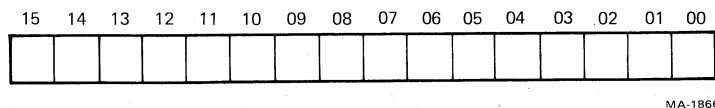

Figure 4-20 RXDB Format (RX11/RXV11)

4.2.2.6 RXES – RX Error and Status (Figure 4-21) – This register contains the current error and status conditions of the drive selected by bit 4 (Unit Select) of the RXCS. This read-only register can be addressed only under the protocol of the function in progress (Paragraph 4.2.3). The RXES content is located in the RXDB upon completion of a function.

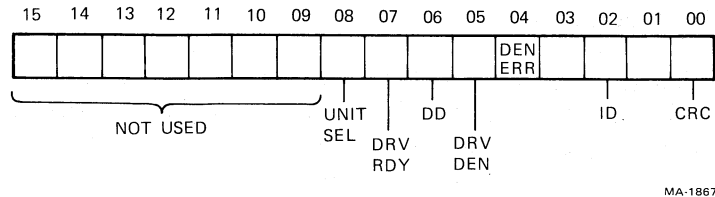

Figure 4-21 RXES Format (RX11, RXV11)

RXES bit assignments are:

Bit No. Description

- 0 CRC Error – A cyclic redundancy check error was detected as information was retrieved from a data field of the diskette. The RXES is moved to the RXDB, and Error and Done are asserted.
- 2 Initialize Done – This bit is asserted in the RXES to indicate completion of the Initialize routine which can be caused by RX02 power failure, system power failure, or programmable or Unibus Initialize.
- 3
- 4 Density Error – This bit is asserted to indicate the density of the function in progress does not match the drive density. Upon detection of this error the control terminates the operation and Error and Done are asserted.

NOTE
Bits 4 and 5 are asserted for the occurrence of double density when the system is RX01-compatible.

- 5 Drive Density – This bit indicates the density of the diskette in the drive selected. When asserted, double density is indicated.
- 6 Deleted Data Detected – During data recovery, the identification mark preceding the data field was decoded as a deleted data mark (Paragraph 1.5.3.2).

- 7 Drive Ready – This bit is asserted if the unit currently selected exists, is properly supplied with power, has a diskette installed correctly, has its door closed, and has a diskette up to speed.

NOTE 1

The drive ready bit is only valid when retrieved via a read status function or at completion of Initialize when it indicates status of drive 0.

NOTE 2

If the error bit was set in the RXCS but error bits are not set in the RXES, specific error conditions can be accessed via a read error register function (Paragraph 4.2.3.7).

- 8 Unit Select – Drive 0 is selected if this bit is “0”; drive 1 is selected if this bit is a “1.”

4.2.3 Function Codes

Following the strict protocol of the individual function, data storage and recovery on the RX11 and RXV11 occur with careful manipulation of the RXCS and RXDB registers. The penalty for violation of protocol can be permanent data loss.

A summary of the function codes is presented below:

000	Fill Buffer
001	Empty Buffer
010	Write Sector
011	Read Sector
100	Not used
101	Read Status
110	Write Deleted Data Sector
111	Read Error Register

The following paragraphs describe in detail the programming protocol associated with each function encoded and written into RXCS bits 1-3 if Done is set.

4.2.3.1 Fill Buffer (000) – This function is used to fill the RX02 buffer with 128 8-bit bytes of data from the host processor. Fill buffer is a complete function in itself; the function ends when the buffer has been filled. The contents of the buffer can be written onto the diskette by means of a subsequent write sector function, or the contents can be returned to the host processor by an empty buffer function.

RXCS bit 4 (Unit Select) does not affect this function since no diskette drive is involved. When the command has been loaded, RXES, OUT, and Done are cleared. When the TR bit is asserted, the first byte of the data may be loaded into the data buffer. The control then clears TR and after supplying the appropriate number of shift pulses to store the data, again asserts TR. The same TR cycle will occur as each byte of data is loaded. The RX02 counts the bytes transferred; it will not accept less than 128 bytes and will ignore those in excess. Any read of the RXDB during the cycle of 128 transfers is ignored by the RX11/RXV11. When the complete buffer has been filled, the control asserts Done.

4.2.3.2 Empty Buffer (001) – This function is used to empty into the interface the buffer of the 128 data bytes loaded from a previous Read Sector or Fill Buffer command. This function will ignore RXCS bit 4 (Unit Select) and negate Done. For this function, TR and shift pulses are generated in the same manner as for the fill buffer but the buffer is emptied.

When TR sets, the program may unload the first of 128 data bytes from the RXDB. Then the RX11/RXV11 again negates TR. When TR resets, the second byte of data may be unloaded from the RXDB, which again negates TR. Alternate checks on TR and data transfers from the RXDB continue until 128 bytes of data have been moved from the RXDB. Done sets, ending the operation.

NOTE

The empty buffer function does not destroy the contents of the sector buffer.

4.2.3.3 Write Sector (010) – This function is used to locate a desired track and sector and write the sector with the contents of the internal sector buffer. The initiation of this function clears TR and Done.

When TR is asserted, the program must move the desired sector address into the RXDB, which will negate TR. When TR is again asserted, the program must load the desired track address into the RXDB, which will negate TR. If the desired track is not found, the RX11/RXV11 will abort the operation, move the contents of the RXES to the RXDB, set RXCS bit 15 (Error), assert Done, and initiate an interrupt if RXCS bit 6 (Interrupt Enable) is set.

TR will remain negated while the RX02 attempts to locate the desired sector. If the RX02 is unable to locate the desired sector within two diskette revolutions, the RX11/RXV11 will abort the operation, move the contents of the RXES to the RXDB, set RXCS bit 15 (Error), assert Done, and initiate an interrupt if RXCS bit 6 (Interrupt Enable) is set.

If the desired sector is successfully located, the RX11/RXV11 will write the 128 bytes stored in the internal buffer followed by a 16-bit CRC character that is automatically calculated by the RX02. The RX11/RXV11 ends the function by asserting Done and initiating an interrupt if RXCS bit 6 (Interrupt Enable) is set.

NOTE 1

The contents of the sector buffer are not valid data after a power loss has been detected by the RX02. The write sector function, however, will be accepted as a valid function, and the random contents of the buffer will be written, followed by a valid CRC.

NOTE 2

The write sector function does not destroy the contents of the sector buffer.

4.2.3.4 Read Sector (011) – This function is used to locate a desired track and sector and transfer the contents of the data field to the μ CPU controller sector buffer. The initiation of this function clears RXES, Done, and OUT.

When TR is asserted, the program must load the desired sector address into the RXDB, which will negate TR. When TR is again asserted, the program must load the desired track address into the RXDB, which will negate TR.

If the desired track is not found, the RX11/RXV11 will abort the operation, move the contents of the RXES to the RXDB, set RXCS bit 15 (Error), assert Done, and initiate an interrupt if RXCS bit 6 (Interrupt Enable) is set.

TR and Done will remain negated while the RX02 attempts to locate the desired track and sector. If the RX02 is unable to locate the desired sector within two diskette revolutions after locating the presumably correct track, the RX11/RXV11 will abort the operation, move the contents of the RXES to the RXDB, set RXCS bit 15 (Error), assert Done, and initiate an interrupt if RXCS bit 6 (Interrupt Enable) is set.

If the desired sector is successfully located, the control will attempt to locate a standard data address mark or a deleted data address mark. If either mark is properly located, the control will read data from the sector into the sector buffer.

If the deleted data address mark was detected, the control will assert RXES bit 6 (DD). As data enters the sector buffer, a CRC is computed, based on the data field and CRC bytes previously recorded. A non-zero residue indicates that a read error has occurred. The control sets RXES bit 0 (CRC Error) and RXCS bit 15 (Error). The RX11/RXV11 ends the operation by moving the contents of the RXES to the RXDB, sets Done, and initiates an interrupt if RXCS bit 6 (Interrupt Enable) is set.

4.2.3.5 Read Status (101) – The RX11/RXV11 will negate RXCS bit 5 (Done) and begin to assemble the current contents of the RXES into the RXDB. RXES bit 7 (Drive Ready) will reflect the status of the drive selected by RXCS bit 4 (Unit Select) at the time the read status function was given. All other RXES bits will reflect the conditions created by the last command. RXES may be sampled when RXCS bit 5 (Done) is again asserted. An interrupt will occur if RXCS bit 6 (Interrupt Enable) is set. RXES bits are defined in Paragraph 4.2.2.6.

NOTE

The average time for this function is 250 ms. Excessive use of this function will result in substantially reduced throughput.

4.2.3.6 Write Sector with Deleted Data (110) – This operation is identical to function 010 (write sector) with the exception that a deleted data address mark precedes the data field instead of a standard data address mark (Paragraph 1.5.3.2).

4.2.3.7 Read Error Code Function (111) – The read error code function can be used to retrieve explicit error information provided by the μ CPU controller upon detection of the general error bit. The function is initiated, and bits 0–6 of the RXES are cleared. Out is asserted and Done is negated. The controller then generates the appropriate number of shift pulses to transfer the specific error code to the interface register and completes the function by asserting Done. The interface register can now be read and the error code interrogated to determine the type of failure that occurred (Paragraph 4.2.6).

NOTE

Care should be exercised in the use of this function, since under certain conditions, erroneous error information may result (Paragraph 4.2.5).

4.2.3.8 Power Fail – There is no actual function code associated with Power Fail. When the RX02 senses a loss of power, it will unload the head and abort all controller action. All status signals are invalid while power is low.

When the RX02 senses the return of power, it will remove Done and begin a sequence to:

1. Move drive 1 head position mechanism to track 0.
2. Clear any active error bits.
3. Read sector 1 of track 1 of drive 0 into the sector buffer.
4. Set RXES bit 2 (Initialize Done) (Paragraph 4.2.2.6) after which Done is again asserted.
5. Set Drive Ready of the RXES according to the status of drive 0.

There is no guarantee that information being written at the time of a power failure will be retrievable. However, all other information on the diskette will remain unaltered.

A method of aborting a function is through the use of RXCS bit 14 (RX Initialize). Another method is through the use of the system Initialize signal that is generated by the PDP-11 RESET instruction, the console START key, or system power failure.

4.2.4 Programming Examples

4.2.4.1 Read Data/Write Data – Figure 4-22 presents a program for implementing a write, write deleted data, or a read function, depending on the function code that is used. The first instructions set up the error retry counters, PTRY, CTRY, and STRY. The instruction RETRY moves the command word for a write, write deleted data, or read into the RXCS.

The set of three instructions beginning at the label 1\$ moves the sector address to the RX11/RXV11 after transfer request (TR), which is bit 7, has been set. The three instructions beginning at the label 2\$ move the track address to the RX11/RXV11 after TR has been set. The group of instructions beginning at the label 3\$ looks for the done flag to set and checks for errors.

An error condition, indicated by bit 15 setting, is checked beginning at ERFLAG. If bit 0 is set, a CRC error has occurred, and a branch is made to CRCER. If a parity error has occurred, a branch is made to PARER. If neither of the above occurs, a seek error is assumed to have occurred and a branch is made to SEEKER, where the system is initialized. In the case of a write function, the sector buffer is refilled by a JMP to FILLBUF. In the case of a read function, a JMP is made to EMPBUFF.

In each of the PAR, CRC, and SEEK routines, the command sequence is retried 10 times by decrementing the respective retry counter. If an error persists after 10 tries, it is a hard error. The retry counters can be set up to retry as many times as desired.

NOTE

A fill buffer function is performed before a write function, and an empty buffer function is performed after a read function.

4.2.4.2 Empty Buffer Function – Figure 4-23 shows a program for implementing an empty buffer function. The first instruction sets the number of error retries to 10. The address of the memory buffer is placed in register R0, and the Empty Buffer command is placed in the RXCS. Existence of a parity error is checked starting at instruction 3\$. If a parity error is detected, the Empty Buffer command is loaded again. If an error persists for 10 retries, the error is considered hard.

If no error is indicated, the program looks for the transfer request (TR) flag to set. The error flag is retested if TR is not set. Once TR sets, a byte is moved from the RX11/RXV11 sector buffer to the core locations of BUFFER. The process continues until the sector buffer is empty and the Done bit is set.

4.2.4.3 Fill Buffer Function – Figure 4-24 presents a program to implement a fill buffer function. It is very similar to the empty buffer example.

4.2.5 Restrictions and Programming Pitfalls

A set of restrictions and programming pitfalls for the RX11/RXV11 is presented below.

1. Depending on how much data handling is done by the program between sectors, the minimum interleave of two sectors may be used, but to be safe a three-sector interleave is recommended.

```

1
2
3
4
5
6       177170
7       177172
8       177172
9       177172
10      177172
11
12      ;ABS
13      ;PROGRAMMING EXAMPLES FOR THE RX11/RX01 FLEXIBLE DISKETTE
14      ;THE FOLLOWING IS THE RX11 STANDARD DEVICE ADDRESS AND VECTOR ADDRESS
15
16      RXCS=177170      ; COMMAND STATUS REGISTER
17      RXDB=177172     ; DATA BUFFER REGISTER
18      RXSA=177172     ; SECTOR ADDRESS REGISTER
19      RXTA=177172     ; TRACK ADDRESS REGISTER
20      RXES=177172     ; ERROR STATUS REGISTER
21
22      ;THE FOLLOWING IS A PROGRAMMING EXAMPLE OF THE PROTOCOL REQUIRED
23      ;TO WRITE, WRITE DELETED DATA, OR READ AT SECTOR "0" (THE CONTENTS OF PROGRAM
24      ;LOCATION SECTOR) OF TRACK "1" (THE CONTENTS OF PROGRAM LOCATION TRACK)
25
26
27      000000 012767 177770 000320 START: MOV #-10, PTRY      ; PARITY RETRY COUNTER
28      000006 012767 177770 000314      MOV #-10, CTRY      ; CRC RETRY COUNTER
29      000014 012767 177770 000310      MOV #-10, STRY      ; SEEK RETRY COUNTER
30
31      ;WRITE, WRITE DELETED DATA, OR READ
32
33      ;BITS 4 THRU 1 OF PROGRAM LOCATION COMMAND CONTAIN THE FUNCTION
34
35      ;BIT 4 = 1 MEANS UNIT 1 ( = 0 MEANS UNIT 0 )
36
37      ;BITS 3 THRU 1 IS THE COMMAND ( 4 = WRITE, 14 = WRITE DELETED DATA, 6 = READ)
38
39      000022 016767 000306 177140 RETRY: MOV COMMAND, RXCS      ; UNIT + (WRITE, WRITE DELETED DATA, OR READ)
40
41      ;WAIT FOR THE TRANSFER REQUEST FLAG THEN TRANSFER THE SECTOR ADDRESS
42
43      1S: TSTB RXCS      ; TEST FOR THE TRANSFER REQUEST FLAG
44      BEQ 1S      ; BEQ UNTIL THE TRANSFER REQUEST FLAG SETS
45      MOVB SECTOR, RXSA      ; LOAD SECTOR ADDRESS
46
47      ;WAIT FOR THE TRANSFER REQUEST FLAG THEN TRANSFER THE TRACK ADDRESS
48
49      2S: TSTB RXCS      ; TEST FOR THE TRANSFER REQUEST FLAG
50      BEQ 2S      ; BEQ UNTIL THE TRANSFER REQUEST FLAG SETS
51      MOVB TRACK, RXTA      ; LOAD TRACK ADDRESS
52
53      ;THE SECTOR AND TRACK ADDRESSES HAVE BEEN TRANSFERRED TO THE RX01
54
55      ;WAIT FOR THE DONE FLAG AND CHECK FOR ANY ERRORS
56
57      ;IF THE FUNCTION HAS COMPLETED SUCCESSFULLY (NO ERROR FLAG) THEN HALT
58
59      3S: BIT #DONEBIT, RXCS      ; TEST FOR THE DONE FLAG
60      BEQ 3S      ; BEQ UNTIL THE DONE FLAG SETS
61      TST RXCS      ; TEST FOR THE ERROR FLAG
62      BNE ERFLAG      ; BNE IF AN ERROR HAS OCCURRED
63      HALT      ; OK = COMPLETED
64
65      ;THE ERROR FLAG IS SET
66
67      ;THE CONTENTS OF THE RXES IS THE ERROR STATUS
68
69      ;IF THE RXES BITS 1 AND 0 = 0 THEN SOME TYPE OF SEEK ERROR OCCURED
70
71      ;IF THE RXES BIT 0 = 1 THEN A CRC ERROR HAS OCCURED
72
73      ;IF THE RXES BIT 1 = 1 THEN A PARITY ERROR HAS OCCURED
74
75      4S: ERFLAG: BIT #3, RXES      ; TEST FOR CRC AND PARITY ERRORS
76      BEQ SEEK      ; NOT A PARITY OR CRC (MUST) BE A SEEK
77      BIT #2, RXES      ; TEST FOR PARITY ERROR
78      BEQ CRC      ; NOT A PARITY ERROR (MUST) BE A CRC
79
80      ;A PARITY ERROR HAS OCCURED
81
82      ;INCREMENT AND TEST THE PARITY ERROR RETRY COUNTER PROGRAM LOCATION " PTRY "
83
84      ;AND RETRY THE " COMMAND " UNTIL THE PARITY ERROR RECOVERS
85
86      ;OR UNTIL THE PTRY COUNTER OVERFLOWS TO 0
87
88      5S: INC PTRY
89      BNE RETRY      ; RETRY THE COMMAND
90      HALT      ; HARD PARITY ERROR
91
92      ;A CRC ERROR HAS OCCURED
93
94      ;INCREMENT AND TEST THE CRC ERROR RETRY COUNTER PROGRAM LOCATION " CTRY "
95
96      ;AND RETRY THE COMMAND UNTIL THE CRC ERROR RECOVERS
97
98      ;OR UNTIL THE CTRY COUNTER OVERFLOWS TO 0
99
100     6S: CRC: INC CTRY
101     BNE RETRY      ; RETRY THE COMMAND
102     HALT      ; HARD CRC ERROR
103
104     ;THE ERROR FLAG IS SET
105
106     ;THE ERROR IS (NOT) A PARITY ERROR AND IS (NOT) A CRC ERROR
107
108     ;THEREFORE IT MUST BE A SEEK ERROR
109
110     ;(STATE OF RXCS BITS 0 AND 1 ARE 0)
111
112     7S: SEEK: MOV #INIT, RXCS      ; INITIALIZE
113
114     ;INCREMENT AND TEST THE SEEK ERROR RETRY COUNTER PROGRAM LOCATION " STRY "
115
116     ;AND RETRY THE COMMAND UNTIL THE SEEK ERROR RECOVERS
117
118     ;OR UNTIL THE CTRY COUNTER OVERFLOWS TO 0
119
120     8S: INC STRY
121     BNE RETRY      ; RETRY THE COMMAND
122     HALT      ; HARD SEEK ERROR
123
124
125
126
127
128
129

```

Figure 4-22 RX11/RXV11 Write/Write Deleted Data/Read Example

```

160 ;THE FOLLOWING IS A PROGRAMMING EXAMPLE OF PROTOCOL REQUIRED TO
161 ;
162 ;EMPTY THE SECTOR BUFFER OF 128 8-BIT BYTES
163 ;
164 000242 012767 177770 000056 EENTRY: MOV #-10, PTRY ; 8 TRYS TO EMPTY THE SECTOR BUFFER
165 000250 012700 000342 ESETUP: MOV #BUFFER, R0 ; PROGRAMS DATA BUFFER
166 000254 016767 000054 176706 MOV COMMAND, RXCS ; ISSUE THE COMMAND
167 ;
168 ;WAIT FOR A TRANSFER REQUEST FLAG BEFORE TRANSFERRING DATA TO THE PROGRAMS
169 ;
170 ;DATA BUFFER FROM THE RX01 SECTOR BUFFER
171 ;
172 ;WAIT FOR A DONE FLAG TO INDICATE THE COMPLETION OF THE EMPTY BUFFER COMMAND
173 ;
174 ;PRIOR TO TESTING THE ERROR FLAG
175 ;
176 000262 105767 176702 ELOOP: TSTB RXCS ; TEST FOR TRANSFER REQUEST FLAG
177 000266 001014 BMI EMPTY ; BNE IF TRANSFER REQUEST FLAG IS SET
178 000270 032767 030040 176672 BIT #DONEBIT, RXCS ; TEST FOR DONE FLAG
179 000276 001771 BEQ ELOOP ; BEQ UNTIL THE DONE FLAG SETS
180 ;
181 ;THE DONE FLAG IS SET
182 ;
183 ;TEST FOR ANY ERRORS (ONLY ERROR POSSIBLE IS A PARITY ERROR)
184 ;
185 000300 005767 176664 TST RXCS
186 000304 001001 BNE IS ; NO ERRORS = OK = COMPLETE
187 000306 000000 HALT
188 ;
189 ;INCFEMENT AND TEST THE PARITY ERROR RETRY PROGRAM LOCATION " PTRY "
190 ;
191 ;AND RETRY THE COMMAND UNTIL THE ERROR RECOVERS
192 ;
193 ;FOR UNTIL THE PTRY CUNTER OVERFLOWS TO 0
194 ;
195 000310 005267 030012 IS: INC PTRY
196 000314 001355 BNE ESETUP ; RETRY TO EMPTY THE SECTOR BUFFER
197 000316 000000 HALT ; HARD PARITY ERROR
198 ;
199 ;THE TRANSFER REQUEST FLAG IS SET
200 ;
201 ;TRANSFER DATA TO THE PROGRAM DATA BUFFER FROM THE RX01 SECTOR BUFFER
202 ;
203 000320 116730 176646 EMPTY: MOVB RXDB, @(R0)+
204 000324 000756 BR ELOOP
205 ;
206 ;THE FOLLOWING 3 PROGRAM LOCATIONS ARE THE ERROR RETRY COUNTERS
207 ;
208 000326 000000 PTRY: 0 ; PARITY ERROR RETRY COUNTER
209 000330 000000 CTRY: 0 ; CRC ERROR RETRY COUNTER
210 000332 000000 STRY: 0 ; SEEK ERROR RETRY COUNTER
211 ;
212 ;PROGRAM LOCATION " COMMAND " CONTAINS THE COMMAND TO BE ISSUED VIA THE LCD IOT
213 ;
214 ;WRITE (4), WRITE DELETED DATA (14), OR READ (6), OR EMPTY BUFFER (2)
215 ;
216 000334 000000 COMMAND: 0 ; 4, 14, 6, OR 2 + (GO BIT 1 = 1)
217 ;
218 ;PROGRAM LOCATION " SECTOR " CONTAINS THE SECTOR ADDRESS (1 TO 32 OCTAL)
219 ;
220 000336 000000 SECTOR: 0 ; 1 TO 32 OCTAL
221 ;
222 ;PROGRAM LOCATION " TRACK " CONTAINS THE TRACK ADDRESS (0 TO 114 OCTAL)
223 ;
224 000340 000000 TRACK: 0 ; 0 TO 114 OCTAL
225 ;
226 ;PROGRAM EQUIVALENTS
227 ;
228 000040 DONEBIT=40
229 040000 INIT=40000
230 000342 BUFFER=,
231 000542 ,#BUFFER+200
232 000001 ,END

```

Figure 4-23 RX11/RXV11 Empty Buffer Example

```

111                                     ;THE FOLLOWING IS A PROGRAMMING EXAMPLE OF THE PROTOCOL REQUIRED TO
112                                     ;
113                                     ;FILL THE SECTOR BUFFER WITH 128 8-BIT BYTES
114                                     ;
115                                     ; NOTE: THE DATA TO FILL THE SECTOR BUFFER CAN BE ASSEMBLED IN CORE IN THE
116                                     ;       EVEN ADDRESSES BYTES OF 128 WORDS OR IN BOTH BYTES OF 64 WORDS
117                                     ;
118 000156 012767 177770 000142 FENTRY: MOV #-10, PTRY           ; 8 TRYS TO FILL THE SECTOR BUFFER
119 000164 012700 000342          SETUP: MOV #BUFFER, R0       ; PROGRAMS DATA BUFFER
120 000170 016767 000140 176772          MOV COMMAND, RXCS      ; ISSUE THE COMMAND
121                                     ;
122                                     ;WAIT FOR A TRANSFER REQUEST FLAG BEFORE TRANSFERRING DATA FROM THE PROGRAMS
123                                     ;DATA BUFFER TO THE RX01 SECTOR BUFFER
124                                     ;
125                                     ;WAIT FOR A DONE FLAG TO INDICATE THE COMPLETION OF THE FILL BUFFER COMMAND
126                                     ;
127                                     ;PRIOR TO TESTING THE ERROR FLAG
128                                     ;
129                                     ;
130 000176 009767 176766          LOOP:  TSTB RXCS           ; TEST FOR TRANSFER REQUEST FLAG
131 000202 001414                  BML FILL           ; BEQ IF TRANSFER REQUEST FLAG SET
132 000204 032767 000040 176756          BIT #DONEBIT, RXCS      ; TEST FOR THE DONE FLAG
133 000212 001771                  BEQ LOOP           ; BEQ UNTIL THE DONE FLAG SETS
134                                     ;
135                                     ;THE DONE FLAG IS SET
136                                     ;
137                                     ;TEST FOR ANY ERRORS (ONLY ERROR POSSIBLE IS A PARITY ERROR)
138                                     ;
139 000214 009767 176750          TST RXCS
140 000220 001001                  BNE 1$
141 000222 000000                  HALT                ; NO ERRORS = OK = COMPLETE
142                                     ;
143                                     ;INCREMENT AND TEST THE PARITY ERROR RETRY PROGRAM LOCATION " PTRY "
144                                     ;
145                                     ;AND RETRY THE COMMAND UNTIL THE ERROR RECOVERS
146                                     ;
147                                     ;FOR UNTIL THE PTRY COUNTER OVERFLOWS TO 0
148                                     ;
149 000224 005267 000076          1$:  INC PTRY
150 000230 001355                  BNE SETUP       ; RETRY TO FILL THE SECTOR BUFFER
151 000232 000000                  HALT                ; HARD PARITY ERROR
152                                     ;
153                                     ;THE TRANSFER REQUEST FLAG IS SET
154                                     ;
155                                     ;TRANSFER DATA FROM THE PROGRAMS DATA BUFFER TO THE RX01 SECTOR BUFFER
156                                     ;
157 000234 113067 176732          FILL:  MOVB @(R0)+, RX0B      ; PROGRAMS DATA BUFFER IS 64 WORDS IN LENGTH
158 000240 000756                  BR LOOP

```

Figure 4-24 RX11/RXV11 Fill Buffer Example

2. If an error occurs and the program executes a read error code function (111), a parity error may occur for that command. The error status would not be for the error in which the read error code function was originally required.
3. The DRV SEL RDY bit is only updated at the time of a read status function (101) for both drives, and after an Initialize, depending on the status of drive 0. At the termination of any other functions it reflects the drive status of the last Read Status or Initialize command.
4. It is not required to load the Drive Select bit into the RXCS when the command is Fill Buffer (000) or Empty Buffer (010).
5. Sector Addressing: 1-26 (No sector 0)
Track Addressing: 0-76
6. A power failure causing the recalibration of the drives will result in a Done condition, the same as finishing reading a sector. However, during a power failure, RXES bit 2 (Initialize Done) will set. Checking this bit will indicate a power fail condition.
7. Excessive use of the read status function (101) will result in drastically decreased throughput, because a read status function requires between one and two diskette revolutions or about 250 ms to complete.

4.2.6 Error Recovery

There are two error indications given by the RX11/RXV11 system. The read status function (Paragraph 4.2.3.5) will assemble the current contents of the RXES (Paragraph 4.2.2.6), which can be sampled to determine errors. The read error code function (Paragraph 4.2.3.7) can also be used to retrieve explicit error information. The RX11/RXV11 interface register can be interrogated to determine the type of failure that occurred. A list of error codes follows.

NOTE

A read status function is not necessary if the DRV RDY bit is not going to be interrogated because the RX2ES is in the interface register at the completion of every function.

Octal Code	Error Code Meaning
0010	Drive 0 failed to see home on Initialize
0020	Drive 1 failed to see home on Initialize
0040	Tried to access a track greater than 77
0050	Home was found before desired track was reached
0070	Desired sector could not be found after looking at 52 headers (2 revolutions)
0110	More than 40 μ s and no SEP clock seen
0120	A preamble could not be found
0130	Preamble found but no ID mark found within allowable time span
0140	CRC error on what appeared to be a header. Error is not asserted
0150	The header track address of a good header does not compare with the desired track
0160	Too many tries for an IDAM (identifies header)
0200	CRC error on reading the sector from the disk
0220	R/W electronics failed maintenance mode test
0240	Density Error

4.3 RX211 AND RXV21 PROGRAMMING INFORMATION

This section describes device registers, register and vector address assignments, programming specifications, and programming examples for the RX211 and RXV21 interfaces.

All software control of the RX211/RXV21 is performed by means of two device registers: the command and status register (RX2CS) and a multipurpose data buffer register (RX2DB) which have been assigned bus addresses and can be read or loaded.

The RX02 contains all the control circuitry required to read from and write on the disk and to calculate and verify the CRC. It has a buffer large enough to hold one full sector of diskette data (128 or 256 8-bit bytes). Information is serially passed between the interface and the RX02.

A typical diskette write sequence, which is initiated by a user program, would occur in two steps:

Fill Buffer – A command to fill the buffer is moved into the RX2CS. The Go bit must be set. The program tests for TR. When TR is detected, the program moves the desired word count into the RX2DB. TR goes false while the word count is moved to the RX02. The program retests TR and moves the bus address into the RX2DB. The device now requests bus mastership and DMA's one data word at a time into the RX2DB and shifts it across the RX02 data bus serially one 8-bit byte at a time into the sector buffer. When the word count register overflows (if necessary, the RX02 control zero-fills the remainder of the sector buffer) the Done bit is set, and an interrupt will occur if the program has enabled interrupts.

Write Sector – A command to write the contents of the sector buffer onto the disk is moved into the RX2CS. The program tests TR and when TR is set, moves the desired sector address to the RX2DB. TR remains false while the sector address is shifted to the RX02 control. The control retests TR and when it is again set, moves the desired track address register to the RX2DB. Again TR is negated. The RX02 locates the desired track and sector and compares the diskette density against the assigned function density and writes the contents of the sector buffer onto the disk if the densities agree. When the write operation is completed, the Done bit is set and an interrupt will occur if the program has enabled interrupts.

A typical disk read operation occurs in the reverse order. First, the desired track and sector are located and the contents of the sector are read into the sector buffer (read sector). Then the contents of the sector buffer is unloaded into memory (empty buffer). In either case, the contents of the sector buffer are not valid if either a Power Fail or Initialize follows a fill buffer or read sector function.

4.3.1 Register and Vector Addresses

The RX211/RXV21 use two registers for communicating with the host computer: the command and status register (RX2CS) normally assigned bus address 177170 and the data buffer register (RX2DB) normally assigned bus address 177172. The vector address is 264.

4.3.2 Register Description

4.3.2.1 RX2CS – Command and Status (177170) – Loading this register while the RX02 is not busy and with bit 0=1 will initiate a function as described below and indicated in Figure 4-25.

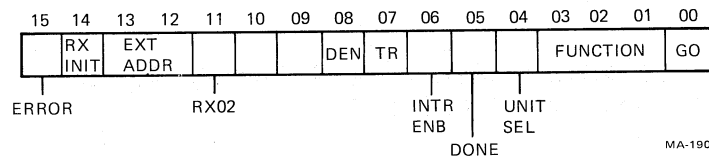

Figure 4-25 RX2CS Format RX211/RXV21

Bit No. Description

- 0 Go – Initiates a command to RX02. This is a write-only bit.
- 1-3 Function Select – These bits code one of the eight possible functions described in Paragraph 4.3.3 and listed below. These are write-only bits.

Code	Function
000	Fill Buffer
001	Empty Buffer
010	Write Sector
011	Read Sector
100	Set Media Density
101	Read Status
110	Write Deleted Data Sector
111	Read Error Code

- 4 Unit select – This bit selects one of the two possible disks for execution of the desired function. This bit is readable only when Done is set, at which time it indicates the unit previously selected. This is a read/write bit.

- 5 Done – This bit indicates the completion of a function. Done will generate an interrupt when asserted if Interrupt Enable (RX2CS bit 6) is set. This is a read-only bit.
- 6 Interrupt Enable – This bit is set by the program to enable an interrupt when the RX02 has completed an operation (Done). The condition of this bit is normally determined at the time a function is initiated. This bit is cleared by Initialize and is a read/write bit.
- 7 Transfer Request – This bit signifies that the RX211/RXV21 needs data or has data available. This is a read-only bit.
- 8 Density – This bit determines the density of the function to be executed. This bit is readable only when Done is set, at which time it indicates the density of the function previously executed. This is a read/write bit.
- 9–10 Reserved for future use. Must be written as a zero.
- 11 RX02 – This bit is set by the interface to inform the programmer that this is an RX02 system. This is a read-only bit.
- 12–13 Extended address – These bits are used to declare an extended bus address. These are write-only bits.
- 14 RX211/RXV21 Initialize – This bit is set by the program to initialize the RX211/RXV21 without initializing all devices on the Unibus. This is a write-only bit.

CAUTION

Loading the lower byte of the RX2CS will also load the upper byte of the RX2CS.

Upon setting this bit in the RX2CS, the RX211/RXV21 will negate Done and move the head position mechanism of both drives (if two are available) to track 0. Upon completion of a successful Initialize, the RX02 will zero the error and status register, and set Initialize Done. It will also read sector 1 of track 1 on drive 0 into the buffer.

- 15 Error – This bit is set by the RX02 to indicate that an error has occurred during an attempt to execute a command. This read-only bit is cleared by the initiation of a new command or an Initialize.

4.3.2.2 RX2DB – Data Buffer Register (177172) – This register serves as a general purpose data path between the RX02 and the interface. It may represent one of six RX02 registers according to the protocol of the function in progress (Paragraph 4.3.3).

This register is read/write if the RX02 is not in the process of executing a command; that is, it may be manipulated without affecting the RX02 subsystem. If the RX02 is actively executing a command, this register will only accept data if RX2CS bit 7 (TR) is set. In addition, valid data can only be read when TR is set.

CAUTION

Violation of protocol in manipulation of this register may cause permanent data loss.

4.3.2.3 RX2TA – RX Track Address (Figure 4-26) – This register is loaded to indicate on which of the 114_8 ($0-76_{10}$) tracks a given function is to operate. It can be addressed only under the protocol of the function in progress (Paragraph 4.3.3). Bits 8–15 are unused and are ignored by the control.

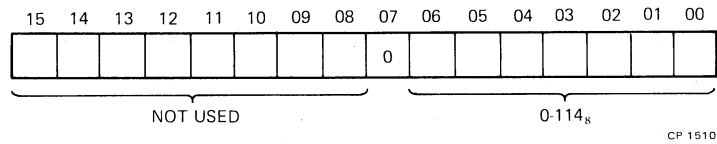

Figure 4-26 RX2TA Format (RX211/RXV21)

4.3.2.4 RX2SA – RX Sector Address (Figure 4-27) – This register is loaded to indicate on which of the 32_8 ($1-26_{10}$) sectors a given function is to operate. It can be addressed only under the protocol of the function in progress (Paragraph 4.3.3).

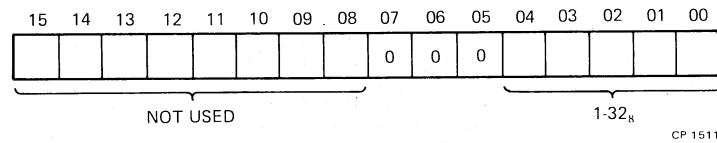

Figure 4-27 RX2SA Format (RX211/RXV21)

4.3.2.5 RX2WC – RX Word Count Register (Figure 4-28) – For a double density sector the maximum word count is 128_{10} . For a single density sector the maximum word count is 64_{10} . If a word count is beyond the limit for the density indicated, the control asserts Word Count Overflow (bit 10 of RX2ES). This is a write-only register. The actual word count and not the 2's complement of the word count is loaded into the register.

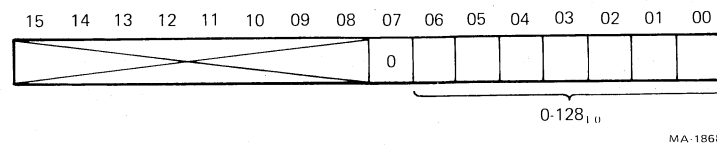

Figure 4-28 RX2WC Format (RX211/RXV21)

4.3.2.6 RX2BA – RX Bus Address Register (Figure 4-29) – This register specifies the bus address of data transferred during fill buffer, empty buffer, and read definitive error operations. Incrementation takes place after a memory transaction has occurred. The RX2BA, therefore, is loaded with the address of the first data word to be transferred. This is a 16-bit, write-only register (Paragraph 4.3.3).

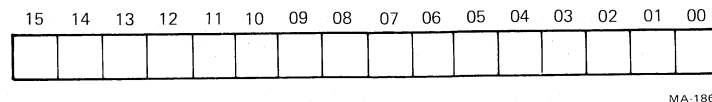

Figure 4-29 RX2BA and RX2DB Format (RX211/RXV21)

4.3.2.7 RX2DB – RX Data Buffer (Figure 4-29) – All information transferred to and from the floppy media passes through this register and is addressable only under the protocol of the function in progress (Paragraph 4.3.3).

4.3.2.8 RX2ES – RX Error and Status (Figure 4-30) – This register contains the current error and status conditions of the drive selected by bit 4 (Unit Select) of the RX2CS. This read-only register can be addressed only under the protocol of the function in progress (Paragraph 4.3.3). The RX2ES is located in the RX2DB upon completion of a function.

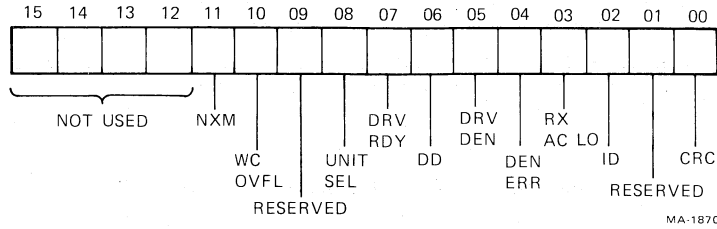

Figure 4-30 RX2ES Format (RX211/RXV21)

RXES bit assignments are:

Bit No. Description

- 0 CRC Error – A cyclic redundancy check error was detected as information was retrieved from a data field of the diskette. The data collected must be considered invalid. The RX2ES is moved to the RX2DB, and Error and Done are asserted. It is suggested that the data transfer be retried up to 10 times, as most errors are recoverable (soft).
- 2 Initialize Done – This bit is asserted in the RX2ES to indicate completion of the Initialize routine which can be caused by RX02 power failure, system power failure, or programmable or bus Initialize.
- 3 RX AC LO – This bit is set by the interface to indicate a power failure in the RX02 subsystem.
- 4 Density Error – This bit indicates that the density of the function in progress does not match the drive density. Upon detection of this error the control terminates the operation and asserts Error and Done.
- 5 Drive Density – This bit indicates the density of the diskette in the drive selected (indicated by bit 8). The density of the drive is determined during read and write sector operations.
- 6 Deleted Data – This bit indicates that in the course of recovering data, the “deleted data” address mark was detected at the beginning of the data field. The Drv Den bit indicates whether the mark was a single or double density deleted data address mark. The data following the mark will be collected and transferred normally, as the deleted data mark has no further significance other than to establish drive density. Any alteration of files or actual deletion of data due to this mark must be accomplished by user software.
- 7 Drive Ready – This bit indicates that the selected drive is ready if bit 7=1 and all conditions for disk operation are satisfied, such as door closed, power okay, diskette up to speed, etc. The RX02 may be presumed to be ready to perform any operation. This bit is only valid when retrieved via a read status function or initialize.
- 8 Unit Select – This bit indicates that drive 0 is selected if bit 8=0. This bit indicates the drive that is currently selected.
- 10 Word Count Overflow – This bit indicates that the word count is beyond sector size. The fill or empty buffer operation is terminated and Error and Done are set.
- 11 Nonexistent Memory Error – This bit is set by the interface when a DMA transfer is being performed and the memory address specified in RX2BA is nonexistent.

4.3.3 Function Codes

Following the strict protocol of the individual function, data storage and recovery on the RX211/RXV21 occur with careful manipulation of the RX2CS and RX2DB registers. The penalty for violation of protocol can be permanent data loss.

A summary of the function codes is presented below:

000	Fill Buffer
001	Empty Buffer
010	Write Sector
011	Read Sector
100	Set Media Density
101	Read Status
110	Write Deleted Data Sector
111	Read Error Code

The following paragraphs describe in detail the programming protocol associated with each function encoded and written into RX2CS bits 1-3 if Done is set.

4.3.3.1 Fill Buffer (000) – This function is used to fill the RX02 data buffer with the number of words of data specified by the RX2WC register. Fill buffer is a complete function in itself: the function ends when RX2WC overflows, and if necessary, the control has zero-filled the remainder of the buffer. The contents of the buffer may be written on the disk by means of a subsequent Write Sector command or returned to the host processor by an Empty Buffer command. If the word count is too large, the function is terminated, Error and Done are asserted, and the Word Count overflow bit is set in RX2ES.

To initiate this function the RX2CS is loaded with the function. Bit 4 of the RX2CS (Unit Select) does not affect this function since no disk operation is involved. Bit 8 (Density) must be properly selected since this determines the word count limit. When the command has been loaded, the Done bit (RX2CS bit 5) goes false. When the TR bit is asserted the RX2WC may be loaded into the data buffer register. When TR is again asserted, the RX2BA may be loaded into the RX2DB. The data words are transferred directly from memory and when RX2WC overflows and the control has zero-filled the remainder of the sector buffer, if necessary, Done is asserted ending the operation. If bit 6 RX2CS (Interrupt Enable) is set, an interrupt is initiated. Any read of the RX2DB during the data transfer is ignored by the interface. After Done is true the RX2ES is located in the RX2DB register.

4.3.3.2 Empty Buffer (001) – This function is used to empty the contents of the internal buffer through the RX211/RXV21 for use by the host processor. This data is in the buffer as the result of a previous Fill Buffer or Read Sector command.

The programming protocol for this function is identical to that for the Fill Buffer command. The RX2CS is loaded with the command to initiate the function. (This function will ignore bit 4 RX2CS, Unit Select). RX2CS bit 8 (Density) must be selected to allow the proper word count limit. When the command has been loaded, the Done bit (RX2CS bit 5) goes false. When the TR bit is asserted, the RX2WC may be loaded into the RX2DB. When TR is again asserted the RX2BA may be loaded into the RX2DB. The RX211/RXV21 assembles one word of data at a time and transfers it directly to memory. Transfers occur until word count overflow, at which time the operation is complete and Done goes true. If bit 6 RX2CS (Interrupt Enable) is set, an interrupt is initiated. After Done is true, the RX2ES is located in the data buffer register.

4.3.3.3 Write Sector (010) – This function is used to locate a desired sector on the diskette and fill it with the contents of the internal buffer. The initiation of the function clears RX2ES, TR, and Done.

When TR is asserted, the program must load the desired sector address into RX2DB, which will drop TR. When TR is again asserted, the program must load the desired track address into the RX2DB, which will drop TR. TR will remain unasserted while the RX02 attempts to locate the desired sector. The diskette density is determined at this time and is compared to the function density. If the densities do not agree, the operation is terminated; bit 4 RX2ES is set, RX2ES is moved to the RX2DB, Error (bit 15 RX2CS) is set, Done is asserted, and an interrupt is initiated, if bit 6 RX2CS (Interrupt Enable) is set.

If the densities agree but the RX02 is unable to locate the desired sector within two diskette revolutions, the interface will abort the operation, move the contents of RX2ES to the RX2DB, set Error (bit 15 RX2CS), assert Done, and initiate an interrupt if bit 6 RX2CS (Interrupt Enable) is set.

If the desired sector has been reached and the densities agree, the RX211/RXV21 will write the 128₁₀ or 64₁₀ words stored in the internal buffer followed by a CRC character which is automatically calculated by the RX02. The RX211/RXV21 ends the function by asserting Done and if bit 6 RX2CS (Interrupt Enable) is set, initiating an interrupt.

CAUTION

The contents of the sector buffer are not valid data after a power loss has been detected by the RX02. However, write sector will be accepted as a valid instruction and the (random) contents of the buffer will be written, followed by a valid CRC.

NOTE

The contents of the sector buffer are not destroyed during a write sector operation.

4.3.3.4 Read Sector (011) – This function is used to locate the desired sector and transfer the contents of the data field to the internal buffer in the control. This function may also be used to retrieve rapidly (5 ms) the current status of the drive selected. The initiation of this function clears RX2ES, TR, and Done.

When TR is asserted the program must load the desired sector address into the RX2DB, which will drop TR. When TR is again asserted, the program must load the desired track address into the RX2DB, which will drop TR.

TR and Done will remain negated while the RX02 attempts to locate the desired sector. If the RX02 is unable to locate the desired sector within two diskette revolutions for any reason, the RXV21/RX211 will abort the operation, set Done and Error (bit 15 RX2CS), move the contents of the RX2ES to the RX2DB, and if bit 6 RX2CS (Interrupt Enable) is set, initiate an interrupt.

If the desired sector is successfully located, the control reads the data address mark and determines the density of the diskette. If the diskette (drive) density does not agree with the function density the operation is terminated and Done and Error (bit 15 RX2CS) are asserted. Bit 4 RX2ES is set (Density Error) and the RX2ES is moved to the RX2DB. If bit 6 RX2CS (Interrupt Enable) is set, an interrupt is initiated.

If a legal data mark is successfully located, and the control and densities agree, the control will read data from the sector into the internal buffer. If a deleted data address mark was detected, the control will set bit 6 RX2ES (DD). As data enters the internal buffer, a CRC is computed based on the data field and the CRC bytes previously recorded. A non-zero residue indicates that a read error has occurred and the control sets bit 0 RX2ES (CRC error) and bit 15 RX2CS (Error). The RX211/RXV21 ends the operation by asserting Done and moving the contents of the RX2ES into the RX2DB. If bit 6 RX2CS is set, an interrupt is initiated.

If the desired sector is successfully located, the densities agree, and the data is transferred with no CRC error, Done will be set and if bit 6 RX2CS (Interrupt Enable) is set the RX211/RXV21 initiates an interrupt.

4.3.3.5 Set Media Density (100) – This function causes the entire diskette to be reassigned to a new density. Bit 8 RX2CS (Density) indicates the new density. The control reformats the diskette by writing new data address marks (double or single density) and zeroing all of the data fields on the diskette.

The function is initiated by loading the RX2CS with the command. Initiation of the function clears RX2ES and Done. When TR is set, an ASCII "I" (111) must be loaded into the RX2DB to complete the protocol. This extra character is a safeguard against an error in loading the command. When the control recognizes this character it begins executing the command.

The control starts at sector 1, track 0 and reads the header information, then starts a write operation. If the header information is damaged, the control will abort the operation.

If the operation is successfully completed, Done is set and if bit 6 RX2CS (Interrupt Enable) is set an interrupt is initiated.

CAUTION

This operation takes about 15 seconds and should not be interrupted. If for any reason the operation is interrupted, an illegal diskette has been generated which may have data marks of both densities. This diskette should again be completely reformatted.

4.3.3.6 Maintenance Read Status (101) – This function is initiated by loading the RX2CS with the command. Done is cleared. The Drive Ready bit (bit 7 RX2ES) is updated by counting index pulses in the control. The Drive Density is updated by loading the head of the selected drive and reading the first data mark. The RX2ES is moved into the RX2DB. The RX2CS may be sampled when Done (bit 5 RX2CS) is again asserted and if bit RX2CS (Interrupt Enable) is set, an interrupt will occur. This operation requires approximately 250 ms to complete.

4.3.3.7 Write Sector with Deleted Data (110) – This operation is identical to function 010 (write sector) with the exception that a deleted data address mark is written preceding the data rather than the standard data address mark. The Density bit associated with the function indicates whether a single or double density deleted data address mark will be written.

4.3.3.8 Read Error Code (111) – The read error code function implies a read extended status. In addition to the specific error code a dump of the control's internal scratch pad registers also occurs. This is the only way that the word count register can be retrieved. This function is used to retrieve specific information as well as drive status information depending upon detection of the general Error bit.

The transfer of the registers is a DMA transfer. The function is initiated by loading the RX2CS with the command and then Done goes false. When TR is true, the RX2BA may be loaded into the RX2DB and TR goes false. The registers are assembled one word at a time and transferred directly to memory.

Register Protocol

Word 1<7:0>	Definitive Error Codes	
Word 1<15:8>	Word Count Register	
Word 2<7:0>	Current Track Address of Drive 0	
Word 2<15:8>	Current Track Address of Drive 1	
Word 3<7:0>	Target Track of Current Disk Access	
Word 3<15:8>	Target Sector of Current Disk Access	
Word 4<7>	Unit Select Bit	*
Word 4<5>	Head Load Bit	*
Word 4<6><4>	Drive Density Bit of Both Drives	*
Word 4<0>	Density of Read Error Register Command	*
Word 4<15:8>	Track Address of Selected Drive	†

* For DMA interfaces the controller status soft register is sent to the interface at the end of the command. The four status bits are included in an 8-bit word. Unit Select = bit 7, Density of Drive 1 = bit 6, Head Load = bit 5, Density of Drive 0 = bit 4, Density of Read Error Register Command = bit 0.

† The Track Address of the Selected Drive - Error is only meaningful on a code 150 error. The register contains the address of the cylinder that the head reached on a seek error.

When the RX02 senses the return of power, it will remove Done and begin a sequence to:

1. Move each drive head position mechanism to track 0
2. Clear any active error bits
3. Read sector 1 of track 1, on drive 0
4. Assert Initialize Done in the RXES.

Upon completion of the power up sequence, Done is again asserted. There is no guarantee that information being written at the time of a power failure will be retrievable; however, all other information on the diskette will remain unaltered.

4.3.3.9 RX02 Power Fail - When the RX02 control senses a loss of power within the RX02, it will unload the head and abort all controller action. The RXAC L line is asserted to indicate to the RX211/RXV21 that subsystem power is gone. The RX211/RXV21 asserts Done and Error and sets the RXAC L bit in the RX2ES.

4.3.4 Error Recovery

There are two error indications given by the RX211/RXV21 system. The maintenance read status function (Paragraph 4.3.3.6) will assemble the current contents of the RX2ES which can be sampled to determine errors. The read error code function (Paragraph 4.3.3.8) can also be retrieved for explicit error information. The RX211/RXV21 interface register can be interrogated to determine the type of failure that occurred. The error codes and their meaning are listed below.

Octal Code	Error Code Meaning
0010	Drive 0 failed to see home on Initialize.
0020	Drive 1 failed to see home on Initialize.
0040	Tried to access a track greater than 76
0050	Home was found before desired track was reached.
0070	Desired sector could not be found after looking at 52 headers (2 revolutions).
0110	More than 40 μ s and no SEP clock seen
0120	A preamble could not be found.
0130	Preamble found but no ID mark found within allowable time span
0150	The header track address of a good header does not compare with the desired track.
0160	Too many tries for an IDAM (identifies header)
0170	Data AM not found in allotted time
0200	CRC error on reading the sector from the disk. No code appears in the ERREG.
0220	R/W electronics failed maintenance mode test.
0230	Word count overflow
0240	Density Error
0250	Wrong key word for set media density command

4.3.5 RX211/RXV21 Programming Examples

4.3.5.1 Write/Fill Buffer

Figure 4-31 illustrates a program to write data on a disk by performing write and fill buffer subroutines. Initially, the write subroutine tests to see if there is an error from the last operation. If there is an error, a branch is made and the write subroutine is not performed; otherwise a jump is made to the fill buffer subroutine. (Before data can be written the RX02 sector buffer must be filled.) The Fill Buffer command is set, the density (single or double) is set, and the command is loaded in the RX02/RXCS. After a TR is received, the word count (for either 128 or 256 bytes of data) is loaded in the RX02/RXDB. After another TR is received, the starting address where data will be retrieved from memory is loaded in the RX02/RXDB. The RX02 controller fills the sector buffer with the number of bytes indicated then the RX02 controller sets the Done bit. (If an Error is detected, the Error bit is set in the RXCS and the program halts.) The program returns to the write subroutine, the drive is selected, the write command and interrupt enable are set, the density is set, and the command is loaded in the RX02/RXCS. There is a wait for TR, then the sector address is loaded in the RX02/RXDB; there is another wait for TR and the track address is loaded in the RX02/RXDB. The data loaded in the sector buffer is written by the RX02 controller on the selected drive (disk) at the selected track and sector. While the controller writes the data, the program waits for an interrupt (which signifies the completion of write data) to occur in order to return to the main program.

```

,SBTIL MODULE 4.0 = WRITE SUBROUTINE
-----
001166 005767 001076 OUTPUT: TST FIN ;IF FIN1 FLAG
001172 001041 BNE ENDOUT ;EQUALS ZERO THEN
001174 004767 000100 JSR PC,008UF2 ;FILL RX02 BUFFER
001200 000240 NOP
001202 016767 001032 001026 MOV UTI,CMD ;SELECT DRIVE
001210 052767 000105 001020 BIS #125,CMD ;SET TO WRITE SECTOR + INT ENABLE
001216 056767 001052 001012 BIS DENSITY,CMD ;SET DENSITY
001224 016777 001006 001076 MOV CMD,0RXCS ;LOAD COMMAND
001232 004767 000710 JSR PC,A*IR ;GO A*WAIT TRANSFER READY
001236 005767 001026 TST FIN ;IF FIN1 FLAG
001242 001015 BNE ENDOUT1 ;EQUALS ZERO THEN
001244 016777 001004 001060 MOV SA,0RXDH ;LOAD SECTOR ADDRESS
001252 004767 000670 JSR PC,A*IR ;GO A*WAIT TRANSFER READY
001256 005767 001006 TST FIN ;IF FIN1 FLAG
001262 001005 BNE ENDOUT ;EQUALS ZERO THEN
001264 016777 000762 001040 MOV TA,0RXDH ;LOAD TRACK ADDRESS
001272 004767 000266 JSR PC,INTER ;WAIT FOR INTERRUPT
001276 000207 ENDOUT1: RTS PC ;RETURN
-----

```

```

,SBTIL MODULE 4.1 = FILL RX02 BUFFER
-----
001300 012767 000061 000730 008UF2: MOV #1,CMD ;SET FILL BUFFER COMMAND
001306 056767 000762 000722 BIS DENSITY,CMD ;SET DENSITY
001314 016777 000716 001006 MOV CMD,0RXCS ;LOAD COMMAND
001322 004767 000620 JSR PC,A*TR ;WAIT FOR "TR"
001326 005767 000736 TST FIN ;IF FIN1 FLAG
001332 001024 BNE ENDOUT2 ;EQUALS ZERO THEN
001334 016777 000726 000770 MOV WDCNT,0RXDB ;LOAD WORD COUNT
001342 004767 000660 JSR PC,A*TR ;WAIT FOR "TR"
001346 005767 000716 TST FIN ;IF FIN1 FLAG
001352 001014 BNE ENDOUT2 ;EQUALS ZERO THEN
001354 012777 002342 000750 MOV #WBHF,0RXDH ;LOAD BASE ADR FOR OUTPUT BUFFER
001362 004767 000500 JSR PC,A*DN ;WAIT FOR "DONE"
001366 005767 000676 TST FIN ;IF FIN1 FLAG
001372 001004 BNE ENDOUT2 ;EQUALS ZERO THEN
001374 005777 000730 TST 0RXCS ;IF DEVICE ERROR BIT
001400 100001 BPL ENDOUT2 ;IS SET THEN
001402 000000 HALT ;ERROR HALT
001404 000207 ENDOUT2: RTS PC ;RETURN
-----

```

MA-1851

Figure 4-31 RX211/RXV21 Write/Fill Buffer Example

4.3.5.2 Read/Empty Buffer

Figure 4-32 illustrates a program to read data from the disk by performing read and empty buffer subroutines. The drive to be read is selected, the read command and interrupt enable are set, the density is set, and the command is loaded in the RX02/RXCS. There is a wait for TR and then the sector address is loaded in the RX02/RXDB; there is another wait for TR, and the track address is loaded in the RX02/RXDB. While the RX02 controller reads data from the selected location on the selected disk into the RX02 sector buffer, the program waits for an interrupt to occur and then there is a jump to the empty buffer subroutine. The empty buffer command is set, the density is set, and the command is loaded into the RX02/RXCS. After a TR is received, the word count is loaded into the RX02/RXDB; there is another wait for TR and the address in memory where the data is to be stored is loaded into the RX02/RXDB. The data is emptied from the sector buffer by the RX02 controller, and when the buffer is emptied, there is a return to the main program.

```

.SBT11 MODULE 2,0 - READ SUBROUTINE
-----
001406 000240      INPUT:  NOP
001410 016767      MOV     UTI,CMD      ;SELECT DRIVE
001416 052767 000624 000620  BIS     #107,CMD     ;SET READ COMMAND + INT ENB
001424 056767 000644 000604  BIS     DENSITY,CMD ;SET DENSITY
001432 016777 000600 000670  MOV     CMD,@RXCS   ;LOAD COMMAND
001440 004767 000502      JSK    PC,@TR      ;GO AWAIT TRANSFER READY
001444 016777 000604 000660  MOV     SA,@RXDB   ;LOAD SECTOR ADDRESS
001452 004767 000470      JSK    PC,@TR      ;GO AWAIT TRANSFER READY
001456 016777 000570 000646  MOV     TA,@RXDB   ;LOAD TRACK ADDRESS
001464 004767 000074      JSK    PC,INTERR   ;WAIT FOR INTERRUPT
001470 004767 000002      JSK    PC,INBUF2   ;THEN GET RX02 BUFFER
001474 000207      ENDIN1: RTS      PC ;RETURN
-----

.SBT11 MODULE 2,2 - EMPTY RX02 BUFFER
-----
001476 012767 000003 000532  INBUF2: MOV     #3,CMD      ;SET EMPTY BUFFER COMMAND
001504 056767 000564 000524  BIS     DENSITY,CMD ;SET DENSITY
001512 016777 000520 000610  MOV     CMD,@RXCS   ;ELSE LOAD COMMAND
001520 004767 000422      JSK    PC,@TR      ;WAIT FOR "TR" DO MOD U,TR
001524 005767 000540      TST    FIM         ;IF FINI FLAG
001530 001014      BNE   ENDIN2      ;EQUALS ZERO
001532 016777 000530 000572  MOV     WDC1,@RXDB ;THEN LOAD WORD COUNT
001540 004767 000402      JSK    PC,@TR      ;WAIT FOR "TR" DO MOD U,TR
001544 005767 000520      TST    FIM         ;IF FINI FLAG
001550 001004      BNE   ENDIN2      ;EQUALS ZERO
001552 012777 002744 000552  MOV     #RBUF,@RXDB ;THEN LOAD BASE ADDR FOR INPUT BUFFER
001560 000240      ENDIN2: NOP
001562 000207      RTS     PC         ;RETURN
-----

.SBT11 MODULE 0,TR - AWAIT TRANSFER READY SUBROUTINE
-----
002146 005067 000060  A:TP:  CLF     TOCNT     ;PRESET TIME OUT COUNTER
002152 032777 000200 000116  BIT     #200,@RXCS ;SEE IF TRANSFER READY SET
002160 001003      BNE   20:         ;IF SO: BR
002162 005267 000044      INC    TOCNT     ;PUMP TIME OUT COUNTER
002166 001371      BPE   10:         ;IF NOT TIMED OUT: BR
002170 000240      20:  NOP
002172 000207      RTS     PC         ;RETURN
-----

```

MA-1852

Figure 4-32 RX211/RXV21 Read/Empty Buffer Example

Your comments and suggestions will help us in our continuous effort to improve the quality and usefulness of our publications.

What is your general reaction to this manual? In your judgment is it complete, accurate, well organized, well written, etc.? Is it easy to use? _____

What features are most useful? _____

What faults or errors have you found in the manual? _____

Does this manual satisfy the need you think it was intended to satisfy? _____

Does it satisfy *your* needs? _____ Why? _____

Please send me the current copy of the *Technical Documentation Catalog*, which contains information on the remainder of DIGITAL's technical documentation.

Name _____ Street _____

Title _____ City _____

Company _____ State/Country _____

Department _____ Zip _____

Additional copies of this document are available from:

Digital Equipment Corporation
444 Whitney Street
Northboro, Ma 01532
Attention: Communications Services (NR2/M15)
Customer Services Section

Order No. EK-RX02-UG-001

Fold Here

Do Not Tear - Fold Here and Staple

**FIRST CLASS
PERMIT NO. 33
MAYNARD, MASS.**

**BUSINESS REPLY MAIL
NO POSTAGE STAMP NECESSARY IF MAILED IN THE UNITED STATES**

Postage will be paid by:

**Digital Equipment Corporation
Technical Documentation Department
Maynard, Massachusetts 01754**

