

**digital**

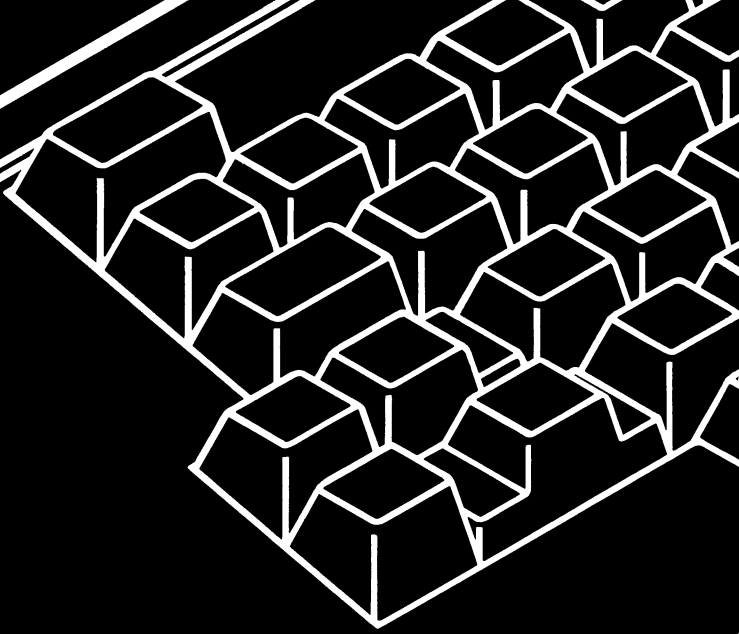

**TECHNICAL MANUAL**

**LA  
120**



LA120  
TECHNICAL MANUAL

Copyright © 1980 by Digital Equipment Corporation  
All Rights Reserved

The material in this manual is for informational purposes and is subject to change without notice. Digital Equipment Corporation assumes no responsibility for any errors which may appear in this manual.

Printed in U.S.A.

**This document was set on DIGITAL's DECset-8000 computerized typesetting system.**

The following are trademarks of Digital Equipment Corporation, Maynard, Massachusetts:

DIGITAL  
DEC  
PDP  
DECUS  
UNIBUS

DECsystem-10  
DECSYSTEM-20  
DIBOL  
EDUSYSTEM  
VAX  
VMS

MASSBUS  
OMNIBUS  
OS/8  
RSTS  
RSX  
IAS

# CONTENTS

	<b>Page</b>
<b>CHAPTER 1 OPERATORS INFORMATION</b>	
1.1 INTRODUCTION.....	1-1
1.2 OPERATOR'S CONSOLE.....	1-2
1.2.1 Lights.....	1-2
1.2.2 Local Control Keys .....	1-4
1.2.3 SET-UP Keys.....	1-4
1.2.4 Control Character Keys.....	1-5
1.2.5 Other Keys .....	1-6
1.2.6 Optional Numeric Keypad .....	1-6
1.2.7 Power ON/OFF Switch and Voltage Selector Switch.....	1-6
1.2.8 Cover Interlock Switch .....	1-8
1.2.9 Paper Adjust Knob.....	1-8
1.2.10 Tractor Adjust Knobs .....	1-9
1.2.11 Carriage Adjustment Lever.....	1-9
1.3 ALARM INDICATORS .....	1-10
1.4 OPERATOR TESTING AND TROUBLESHOOTING .....	1-11
<b>CHAPTER 2 INSTALLATION, INTERFACE, AND SPECIFICATIONS</b>	
2.1 INSTALLATION AND CONFIGURATION.....	2-1
2.1.1 Unpacking and Inspection.....	2-2
2.1.2 Packing Procedures .....	2-2
2.1.3 Checkout Procedure .....	2-5
2.1.4 Answerback Jumper .....	2-6
2.2 INTERFACE INFORMATION .....	2-8
2.2.1 Interface Signals .....	2-8
2.2.1.1 Protective Ground.....	2-8
2.2.1.2 Transmitted Data (TDX).....	2-8
2.2.1.3 Received Data (RDX) .....	2-8
2.2.1.4 Request to Send (RTS) .....	2-9
2.2.1.5 Clear to Send (CTS).....	2-9
2.2.1.6 Data Set Ready .....	2-9
2.2.1.7 Signal Ground.....	2-9
2.2.1.8 Carrier Detect (RLSD) .....	2-9
2.2.1.9 Secondary Request to Send (SRTS) .....	2-9
2.2.1.10 Speed Indicator (SPDI) .....	2-9
2.2.1.11 Secondary Carrier Detect (SRLSD).....	2-9
2.2.1.12 Data Terminal Ready (DTR).....	2-9
2.2.1.13 Ring Indicator (RI) .....	2-9
2.2.1.14 Speed Select (SPDS) .....	2-9
2.2.2 EIA Interface Cables .....	2-9
2.2.2.1 BC22A-10, -25 .....	2-10
2.2.2.2 BC22B-10, -25 .....	2-10
2.2.3 Impedance of Terminator .....	2-10
2.2.4 Rise and Fall Times .....	2-10
2.2.5 Open Circuit Voltage.....	2-10
2.3 LA120 SPECIFICATIONS.....	2-10

## CONTENTS (Cont)

	Page
<b>CHAPTER 3</b>	<b>PROGRAMMER'S INFORMATION</b>
3.1	GENERAL.....3-1
3.2	ESCAPE SEQUENCES.....3-2
3.2.1	Parser Program .....3-2
3.2.2	Sequence Descriptions.....3-2
3.2.2.1	Printer Character Sets.....3-5
3.2.2.2	Active Position .....3-6
3.2.2.3	Linefeed-Newline Mode .....3-7
3.2.2.4	Horizontal Pitch.....3-7
3.2.2.5	Horizontal Margins.....3-8
3.2.2.6	Horizontal Tabs .....3-8
3.2.2.7	Vertical Pitch.....3-8
3.2.2.8	Form Length .....3-8
3.2.2.9	Vertical Margins.....3-8
3.2.2.10	Vertical Tabs .....3-9
3.2.2.11	Product Identification .....3-9
3.2.2.12	Alternate Keypad Mode.....3-9
3.3	CONTROL CHARACTERS.....3-10
3.3.1	Null or Delete (NULL or DEL).....3-10
3.3.2	End of Text (ETX).....3-10
3.3.3	End of Transmission (EOT).....3-10
3.3.4	Enquiry (ENQ).....3-10
3.3.5	Bell (BEL) .....3-11
3.3.6	Backspace (BS).....3-11
3.3.7	Horizontal Tab (HT) .....3-11
3.3.8	Line Feed (LF) .....3-11
3.3.9	Vertical Tab (VT) .....3-11
3.3.10	Form Feed (FF).....3-11
3.3.11	Carriage Return (CR).....3-11
3.3.12	Shift In (SI).....3-11
3.3.13	Shift Out (SO).....3-11
3.3.14	Data Link Escape (DLE) .....3-11
3.3.15	Cancel (CAN).....3-11
3.3.16	Substitute (SUB).....3-11
3.3.17	Escape (ESC).....3-12
3.4	APL CHARACTER SET.....3-12
3.5	SAMPLE FORM SETUP USING ESCAPE SEQUENCES .....3-13
3.6	SYNCHRONIZATION .....3-13
3.6.1	Synchronization Limits.....3-15
3.6.2	Fill Time Formulas.....3-15
3.6.2.1	Horizontal Movement .....3-15
3.6.2.2	Vertical Movement .....3-15
3.7	KEYBOARD OPERATION .....3-16
3.7.1	Auto Repeat .....3-16
3.7.2	Printable Character Keys.....3-16
3.7.3	Control Character Keys.....3-17
3.7.4	CTRL (Control) Key .....3-17

## CONTENTS (Cont)

	<b>Page</b>
3.7.5	Optional Auxiliary Keypad.....3-18
3.7.6	BREAK Key .....3-18
3.7.7	VIEW Key.....3-18
<b>CHAPTER 4</b>	<b>LA120 THEORY OF OPERATION</b>
4.1	<b>BASIC SYSTEM CONFIGURATION .....4-1</b>
4.1.1	Microprocessor .....4-1
4.1.2	Device Addressing .....4-1
4.1.2.1	Memory Space .....4-3
4.1.2.2	I/O Space.....4-3
4.1.3	Interrupts .....4-3
4.1.4	ROM .....4-4
4.1.5	RAM .....4-5
4.1.6	Keyboard .....4-5
4.1.6.1	Keyboard Addressing.....4-5
4.1.6.2	Switch Matrix.....4-7
4.1.6.3	Separately Decoded Keys .....4-7
4.1.7	Display.....4-7
4.1.7.1	LEDs .....4-7
4.1.7.2	Seven Segment Display .....4-7
4.1.8	Non-Volatile Memory .....4-8
4.1.9	DC305 Printer Controller .....4-9
4.1.10	8251A USART.....4-9
4.1.11	Utility I/O Ports.....4-10
4.2	<b>DC305 PRINTER CONTROLLER.....4-10</b>
4.2.1	Dot Print Control.....4-10
4.2.2	Carriage Position Count .....4-11
4.2.3	Carriage Speed Control .....4-11
4.2.4	Line Feed Control .....4-11
4.2.5	Bell Control.....4-11
4.2.6	Frequency Generation .....4-11
4.2.7	Tick Alarm .....4-11
4.2.8	Interrupt Vectors .....4-12
4.3	<b>LA120 FIRMWARE OVERVIEW .....4-12</b>
4.3.1	Scheduling.....4-12
4.3.2	ROM Layout.....4-12
4.3.3	RAM Layout.....4-13
4.4	<b>PRINT CONTROL FIRMWARE.....4-13</b>
4.4.1	Starting the Printing Operation.....4-13
4.4.2	Flight Time Compensation .....4-15
4.4.3	Dot Rate Limiting .....4-15
4.5	<b>CARRIAGE SERVO FIRMWARE.....4-16</b>
4.5.1	Transitions .....4-16
4.5.2	Reading the Position Counter .....4-16
4.5.3	Carriage Speed Command .....4-16
4.5.4	Error Conditions .....4-16
4.6	<b>COMMUNICATION FIRMWARE.....4-17</b>
4.6.1	Communication Modes .....4-17

## CONTENTS (Cont)

		Page
4.6.2	Local Mode.....	4-17
4.6.3	Disconnects.....	4-17
4.6.4	Full Duplex Without EIA Controls.....	4-17
4.6.5	Full Duplex with EIA Controls.....	4-17
4.6.5.1	Full-Duplex Break.....	4-18
4.6.5.2	Full-Duplex Disconnect.....	4-18
4.6.5.3	Restraint Mode.....	4-19
4.6.5.4	Speed Control Mode.....	4-19
4.6.6	Half Duplex.....	4-19
4.6.6.1	Initial Direction Determination.....	4-19
4.6.6.2	Reverse Channel.....	4-19
4.6.6.3	Request to Send Delay.....	4-19
4.6.6.4	Turnaround Characters.....	4-20
4.6.6.5	Half-Duplex Break.....	4-20
4.6.6.6	Half-Duplex Disconnect.....	4-20
4.6.7	Communication State Control.....	4-21
4.6.7.1	Communication State Table.....	4-21
4.6.7.2	Communication Handler.....	4-21
4.6.8	Control Code Generation and Detection.....	4-23
4.6.8.1	Input Scanning.....	4-23
4.6.8.2	Transmit Scanning.....	4-23
4.6.8.3	Control Code Generation.....	4-23
4.6.9	Functional State Diagrams.....	4-23
4.7	ESCAPE SEQUENCE PROCESSING.....	4-28
4.7.1	Escape Sequence State Transition Table.....	4-28
4.7.1.1	Element No. 1.....	4-29
4.7.1.2	Element No. 2.....	4-30
4.7.1.3	Element No. 3.....	4-30
4.7.1.4	Element No. 4.....	4-30
4.7.1.5	Element No. 5.....	4-30
4.7.1.6	Element No. 6.....	4-31
4.7.1.7	Element No. 7.....	4-31
4.7.2	Escape Sequence Jump Table.....	4-31
4.7.3	Escape Sequence Parser.....	4-31
4.7.3.1	Begin Parsing.....	4-31
4.7.3.2	Initialize Parser.....	4-32
4.7.3.3	Flow Controller.....	4-32
4.7.4	CSI Parameters.....	4-33
4.7.5	Control Strings.....	4-33
4.7.6	Final Character Perform-Function Routines.....	4-33
4.8	SET-UP COMMAND PROCESSING.....	4-33
4.8.1	SET-UP Command Implementation.....	4-34
4.8.1.1	Multiple Choice SET-UP Commands.....	4-34
4.8.1.2	Immediate Action SET-UP Commands.....	4-34
4.8.2	SET-UP Handler.....	4-35
4.8.3	SET-UP/Keyboard Handler Relationship.....	4-36
4.9	CHARACTER PROCESSING.....	4-36
4.9.1	Character Reception.....	4-36
4.9.2	Background Executive.....	4-36
4.9.3	Print Line Builder.....	4-37
4.9.4	Answerback Entry Handler.....	4-38



## CONTENTS (Cont)

	<b>Page</b>
<b>CHAPTER 5</b>	<b>TROUBLESHOOTING THE LA120</b>
5.1	GENERAL.....5-1
5.2	DC SERVO TEST .....5-8
5.3	ENCODER DUTY CYCLE CHECK/ADJUSTMENT .....5-9
5.4	CLOCK TEST .....5-12
5.5	WAKE UP TEST.....5-12
5.6	PRINT CHARACTER TEST .....5-14
5.7	USART TEST.....5-17
5.8	KEYBOARD TEST.....5-21
5.9	LINE FEED TEST .....5-24
5.10	BELL TEST .....5-27
<b>CHAPTER 6</b>	<b>LA120 SUBASSEMBLY REMOVAL AND INSTALLATION</b>
6.1	GENERAL.....6-1
6.2	PRINTER HOUSING .....6-1
6.2.1	Printer Housing Removal.....6-1
6.2.2	Printer Housing Installation .....6-3
6.3	PRINT HEAD ASSEMBLY .....6-3
6.3.1	Print Head Assembly Removal.....6-4
6.3.2	Print Head Assembly Installation .....6-4
6.4	PRINT HEAD CABLE .....6-5
6.4.1	Print Head Cable Removal.....6-5
6.4.2	Print Head Cable Installation .....6-5
6.5	TIMING BELT .....6-6
6.5.1	Timing Belt Removal.....6-6
6.5.2	Timing Belt Installation.....6-6
6.6	PRINT BAR.....6-8
6.6.1	Print Bar Removal.....6-8
6.6.2	Print Bar Installation.....6-8
6.7	CARRIAGE ASSEMBLY AND FRONT CARRIAGE SHAFT .....6-9
6.7.1	Carriage Assembly and Front Carriage Shaft Removal.....6-9
6.7.2	Carriage Assembly and Front Carriage Shaft Installation .....6-11
6.8	CARRIAGE ECCENTRIC BEARING AND LEVER .....6-11
6.8.1	Carriage Eccentric Bearing and Lever Removal .....6-11
6.8.2	Carriage Eccentric Bearing and Lever Installation.....6-11
6.9	REAR CARRIAGE SHAFT AND PLAIN BUSHING .....6-13
6.9.1	Rear Carriage Shaft and Plain Bushing Removal .....6-13
6.9.2	Rear Carriage Shaft and Plain Bushing Installation.....6-14
6.10	RIBBON DRIVE PULLEY .....6-14
6.10.1	Ribbon Drive Pulley Removal .....6-14
6.10.2	Ribbon Drive Pulley Installation .....6-14
6.11	RIBBON DRIVE ASSEMBLY.....6-15
6.11.1	Ribbon Drive Assembly Removal.....6-15
6.11.2	Ribbon Drive Assembly Installation .....6-17
6.12	RIBBON DRIVE FAFNIR BEARING.....6-18
6.12.1	Ribbon Drive Fafnir Bearing Removal .....6-18
6.12.2	Ribbon Drive Fafnir Bearing Installation .....6-18
6.13	RIBBON ECCENTRIC AND BACKSTOP SPRING .....6-19
6.13.1	Ribbon Eccentric and Backstop Spring Removal .....6-19

## CONTENTS (Cont)

		<b>Page</b>
6.13.2	Ribbon Eccentric and Backstop Spring Installation .....	6-20
6.14	DC MOTOR AND ENCODER ASSEMBLY .....	6-20
6.14.1	DC Motor and Encoder Assembly Removal .....	6-20
6.14.2	DC Motor and Encoder Assembly Installation .....	6-21
6.15	TRACTOR DRIVE SHAFTS AND TRACTOR ASSEMBLIES .....	6-22
6.15.1	Tractor Drive Shaft and Tractor Assembly Removal.....	6-22
6.15.2	Tractor Drive Shaft and Tractor Assembly Installation.....	6-23
6.16	IDLER GEAR ASSEMBLY.....	6-24
6.16.1	Idler Gear Assembly Removal .....	6-24
6.16.2	Idler Gear Assembly Installation .....	6-24
6.17	STEPPING MOTOR ASSEMBLY.....	6-25
6.17.1	Stepping Motor Assembly Removal.....	6-25
6.17.2	Stepping Motor Assembly Installation.....	6-26
6.18	RIBBON CHASSIS ASSEMBLY .....	6-27
6.18.1	Ribbon Chassis Assembly Removal .....	6-27
6.18.2	Ribbon Chassis Assembly Installation .....	6-28
6.19	RIBBON SPOOL RATCHET WHEELS AND FRICTION DISKS.....	6-29
6.19.1	Ribbon Spool Ratchet Wheel(s) and Friction Disk Removal.....	6-29
6.19.2	Ribbon Spool Ratchet Wheel(s) and Friction Disk Installation.....	6-30
6.20	KEYBOARD/NUMERIC PAD ASSEMBLY .....	6-30
6.20.1	Keyboard/Numeric Pad Assembly Removal .....	6-30
6.20.2	Keyboard/Numeric Pad Assembly Installation.....	6-31
6.21	POWER SUPPLY ASSEMBLY .....	6-32
6.21.1	Power Supply Assembly Removal.....	6-33
6.21.2	Power Supply Assembly Installation .....	6-34
6.22	PRINTER MECHANISM ASSEMBLY .....	6-35
6.22.1	Printer Mechanism Assembly Removal.....	6-35
6.22.2	Printer Mechanism Assembly Installation.....	6-35
6.23	CVT POWER SUPPLY MODULE .....	6-38
6.23.1	CVT Power Supply Module Removal .....	6-38
6.23.2	CVT Power Supply Module Installation .....	6-39
6.24	POWER ENTRY BRACKET ASSEMBLY .....	6-39
6.24.1	Power Entry Bracket Assembly Removal.....	6-40
6.24.2	Power Entry Bracket Assembly Installation .....	6-40
6.25	FAN .....	6-40
6.25.1	Fan Removal.....	6-40
6.25.2	Fan Installation .....	6-40
6.26	LOGIC/POWER BOARD .....	6-41
6.26.1	Logic/Power Board Removal .....	6-41
6.26.2	Logic/Power Board Installation .....	6-42

### CHAPTER 7 ADJUSTMENT PROCEDURES AND LUBRICATION

7.1	PRINT HEAD ADJUSTMENT.....	7-1
7.2	PRINTER MECHANISM ADJUSTMENT .....	7-1
7.3	PAPER GUIDE ADJUSTMENT .....	7-4
7.4	PAPER OUT SWITCH ADJUSTMENT .....	7-5
7.5	RIBBON TENSION ADJUSTMENT.....	7-6
7.6	RIBBON DRIVE ASSEMBLY ADJUSTMENT .....	7-8

## CONTENTS (Cont)

		Page
7.7	IDLER GEAR ASSEMBLY ADJUSTMENT.....	7-11
7.8	BUMPER ASSEMBLY ADJUSTMENT.....	7-12
7.9	PRINT BAR ADJUSTMENT.....	7-13
7.10	LUBRICATION.....	7-15
<b>CHAPTER 8</b>	<b>20 mA LA12X-AL OPTION</b>	
8.1	GENERAL.....	8-1
8.2	INSTALLATION.....	8-1
8.3	TEST AFTER INSTALLATION.....	8-3
8.4	ELECTRICAL CHARACTERISTICS.....	8-3
8.4.1	Transmitter.....	8-3
8.4.2	Receiver.....	8-3
8.4.3	Pin Assignments.....	8-3
<b>CHAPTER 9</b>	<b>EXPANDED BUFFER OPTION LA12X-DL</b>	
<b>CHAPTER 10</b>	<b>LA120-RE</b>	
10.1	INTRODUCTION.....	10-1
10.2	INSTALLATION.....	10-1
<b>CHAPTER 11</b>	<b>LA12X-HL KEYBOARD OPTION</b>	
11.1	INTRODUCTION.....	11-1
11.2	INSTALLATION.....	11-1
11.3	OPERATOR'S INFORMATION.....	11-6
<b>CHAPTER 12</b>	<b>LA12X-YL OPTION</b>	
12.1	INTRODUCTION.....	12-1
12.2	INSTALLATION.....	12-1
12.3	OPERATOR'S INFORMATION.....	12-7
12.3.1	Indicator Lights.....	12-7
12.3.2	Control Keys.....	12-7
12.3.3	SET-UP Mode.....	12-9
12.3.4	Baud Rate (Speed).....	12-10
12.3.5	Parity and Data Bits.....	12-10
12.3.6	Setting Form Length.....	12-11
12.3.7	Printer New Line Character.....	12-12
12.3.8	Modem.....	12-13
12.3.9	Secondary Channel.....	12-14
12.3.10	Status.....	12-15
12.3.11	Store/Recall.....	12-16
<b>APPENDIX A</b>	<b>LA120 OPERATOR REFERENCE CARD</b>	
<b>APPENDIX B</b>	<b>FACTORY PARAMETER SETTINGS</b>	

## FIGURES

Figure	Title	Page
1-1	Operator's Console .....	1-3
1-2	Basic System Using LA120 .....	1-3
1-3	Location of Power ON/OFF Switch and Voltage Selector Switch.....	1-7
1-4	Location of Cover Interlock Switch .....	1-8
1-5	Paper Adjust Knob .....	1-8
1-6	Tractor Adjust Knobs .....	1-9
1-7	Carriage Adjustment Lever .....	1-9
2-1	LA120 Site Considerations .....	2-1
2-2	Unpacking/Packing .....	2-3
2-3	Location of Nylon Cable Tie .....	2-4
2-4	Location of LA120 SET-UP Label .....	2-4
2-5	Self-Test Printout .....	2-6
2-6	Location of Answerback Jumper .....	2-7
3-1	Sample Form SET-UP.....	3-14
3-2	Octal Codes Generated by Keyboard.....	3-16
3-3	Characters Generated by Keyboard with CTRL Key Held Down .....	3-8
4-1	LA120 Block Diagram .....	4-2
4-2	ROM Placement .....	4-4
4-3	RAM Address Map.....	4-5
4-4	Forward Print Start.....	4-14
4-5	Reverse Print Start .....	4-15
4-6	Note A Branch Form.....	4-23
4-7	Full Duplex.....	4-24
4-8	Supervisory Control .....	4-25
4-9	Coded Control with Reverse Channel .....	4-26
4-10	Coded Control Without Reverse Channel.....	4-29
4-11	Entry Organization Within a Table Element .....	4-29
5-1	Logic/Power Board Connectors .....	5-7
5-2	DC Servo Signals .....	5-9
5-3	Encoder Output Waveform .....	5-10
5-4	Encoder Circuit Board.....	5-11
5-5	$\phi 1$ and $\phi 2$ Clock Signals .....	5-12
5-6	8080A Addressing Output .....	5-13
5-7	DC Wake Up Waveform .....	5-13
5-8	Solenoid Signal Output of DC305.....	5-15
5-9	Drive Signal to Print Solenoid .....	5-16
5-10	Head Enable vs Drive Signal.....	5-17
5-11	LA120 Baud Rate Clocks .....	5-18
5-12	USART I/O Signals.....	5-20
5-13	Keyboard Scan Waveform.....	5-21
5-14	Keyboard Scan Waveform with Key Pressed .....	5-22
5-15	Key Circuit Waveform .....	5-23
5-16	Keyboard Scan for Chip E8.....	5-23
5-17	Line Feed Signal Output of DC305.....	5-24
5-18	Line Feed Amplifier Input vs Output.....	5-25
5-19	Line Feed Run Signal .....	5-26
5-20	Bell Amplifier Input .....	5-27
5-21	Bell Amplifier Output.....	5-28

## FIGURES (Cont)

Figure No.	Title	Page
6-1	Assembly Removal Sequence .....	6-2
6-2	Printer Housing Removal and Installation.....	6-3
6-3	Print Head Removal and Installation .....	6-4
6-4	Print Head Cable.....	6-6
6-5	Belt Tension Spring Location .....	6-7
6-6	Belt Tension Spring (Detailed View).....	6-8
6-7	Carriage Assembly and Front Carriage Shaft Removal and Installation.....	6-9
6-8	Carriage Eccentric Bearing and Lever Removal and Installation .....	6-12
6-9	Rear Carriage Shaft and Plain Bushing Removal and Installation .....	6-13
6-10	Ribbon Drive Pulley Removal and Installation.....	6-15
6-11	Ribbon Drive Assembly Removal and Installation .....	6-16
6-12	Ribbon Drive Assembly (Detailed View) .....	6-17
6-13	Fafnir Bearing and Ribbon Eccentric Removal and Installation.....	6-19
6-14	DC Motor/Encoder Assembly Removal and Installation .....	6-21
6-15	Tractor Drive Shaft and Tractor Assembly Removal and Installation .....	6-22
6-16	Tractor Phasing Adjustment.....	6-23
6-17	Idler Gear Assembly Removal and Installation.....	6-24
6-18	Stepping Motor Assembly Removal and Installation .....	6-25
6-19	Stepping Motor Mounted on Side Plate.....	6-26
6-20	Ribbon Chassis Assembly Removal and Installation.....	6-27
6-21	Cover Interlock Switch.....	6-28
6-22	Ribbon Spool Ratchet Wheel and Friction Disk Replacement .....	6-29
6-23	Keyboard/Numeric Pad Removal and Installation.....	6-31
6-24	Power Supply Assembly Removal and Installation .....	6-32
6-25	Power Supply Assembly in Position .....	6-34
6-26	Printer Mechanism Assembly Removal and Installation .....	6-36
6-27	Cabinet Reference Holes .....	6-37
6-28	CVT Power Supply Module Removal and Installation.....	6-38
6-29	Power Entry Bracket Assembly Removal and Installation.....	6-39
6-30	Fan Removal and Installation .....	6-41
6-31	Logic/Power Board Removal and Installation.....	6-42
7-1	Print Head Adjustment .....	7-2
7-2	Printer Mechanism Alignment.....	7-3
7-3	Paper Guide Adjustment.....	7-4
7-4	Paper Out Switch Adjustment .....	7-5
7-5	Ribbon Spool Tension Adjustment.....	7-6
7-6	Ribbon Threading/ Drag Test.....	7-7
7-7	Ribbon Drive Adjustment.....	7-9
7-8	Ribbon Drive Assembly .....	7-10
7-9	Idler Gear Assembly.....	7-11
7-10	Bumper Assembly Adjustment .....	7-12
7-11	Print Bar Adjustment .....	7-14
7-12	Carriage Shaft Lubrication .....	7-15
7-13	Ribbon Drive Assembly Lubrication .....	7-16
8-1	Installation of 20 mA LA12X-AL Option.....	8-2
8-2	20 mA Current Loop Connector.....	8-3
10-1	LA12X-HL Keyboard.....	10-2
10-2	LA12X-YL Keypad.....	10-3

## FIGURES (Cont)

Figure No.	Title	Page
11-1	Printer Housing Removal and Installation.....	11-2
11-2	Terminator Card Removal .....	11-3
11-3	Keyboard Cable Installation.....	11-4
11-4	Keyboard Installation .....	11-5
11-5	Label Installation .....	11-6
12-1	Printer Housing Removal and Installation.....	12-2
12-2	Terminator Card Removal .....	12-3
12-3	Keyboard Cable Installation.....	12-4
12-4	Keypad Installation.....	12-5
12-5	Self-Test Printout .....	12-6
12-6	Form Length .....	12-11

## TABLES

Table	Title	Page
1-1	Related Documentation .....	1-1
1-2	LA120 Console Indicators.....	1-2
1-3	LA120 Console Local Control Keys .....	1-4
1-4	LA120 Console SET-UP Keys.....	1-4
1-5	LA120 Console Control Character Keys.....	1-5
1-6	LA120 Console Miscellaneous Keys .....	1-6
1-7	Alarm Indicators .....	1-10
1-8	LA120 Internal Tests .....	1-11
1-9	Operator Troubleshooting.....	1-11
2-1	Summary of LA120 EIA Interface Signals .....	2-8
2-2	Printer Specifications.....	2-10
2-3	Keyboard Specifications.....	2-12
2-4	Communications Specifications.....	2-13
2-5	Physical Specifications.....	2-14
2-6	Paper Specifications .....	2-15
3-1	LA120 Escape Sequences.....	3-3
3-2	United States ASCII Character Set.....	3-6
3-3	Code Differences Among National Character Sets.....	3-7
3-4	Escape Sequences Transmitted in Alternate Keypad Mode .....	3-9
3-5	LA120 Control Characters .....	3-10
3-6	APL Character Set .....	3-12
3-7	Escape Sequences for Sample Form .....	3-13
3-8	Synchronization Limits .....	3-15
3-9	Control Character Keys.....	3-17
3-10	Variations in Control Character Locations .....	3-17
4-1	LA120 Memory Read/Write Decoding .....	4-3
4-2	I/O Space Allocation .....	4-3
4-3	Interrupt Vectors.....	4-4
4-4	Keyboard Addressing.....	4-6

## TABLES (Cont)

Table No.	Title	Page
4-5	LA120 LEDs.....	4-7
4-6	Seven Segment Display Counter.....	4-8
4-7	Non-Volatile Memory Operations.....	4-8
4-8	8251A USART Ports.....	4-9
4-9	Utility I/O Ports.....	4-10
4-10	Disconnect Generation vs SET-UP Commands.....	4-18
5-1	LA120 Troubleshooting Procedure.....	5-2
5-2	DC Supply Voltages.....	5-8
5-3	Line Feed Amplifier Test.....	5-26
7-1	Lubrication Points.....	7-15
8-1	20 mA LA12X-AL Option Kit.....	8-1
11-1	LA12X-HL Installation Kit.....	11-1
12-1	LA12X-YL Installation Kit.....	12-1
12-2	Printing Self-Test.....	12-6
12-3	Nonprinting Self-Test.....	12-6
12-4	Entering/Exiting SET-UP Mode.....	12-9
12-5	Baud Rate Selection.....	12-10
12-6	Parity/Data Bits Selection.....	12-11
12-7	Form Length Selection.....	12-12
12-8	Carriage Return/Line Feed Responses.....	12-12
12-9	Selection of Carriage Return/Line Feed Responses.....	12-13
12-10	Modem Selection.....	12-13
12-11	Secondary Channel Selection.....	12-14
12-12	Status Printout Procedure.....	12-15
12-13	LA120 Store Procedure.....	12-16
12-14	LA120 Recall Procedure.....	12-16

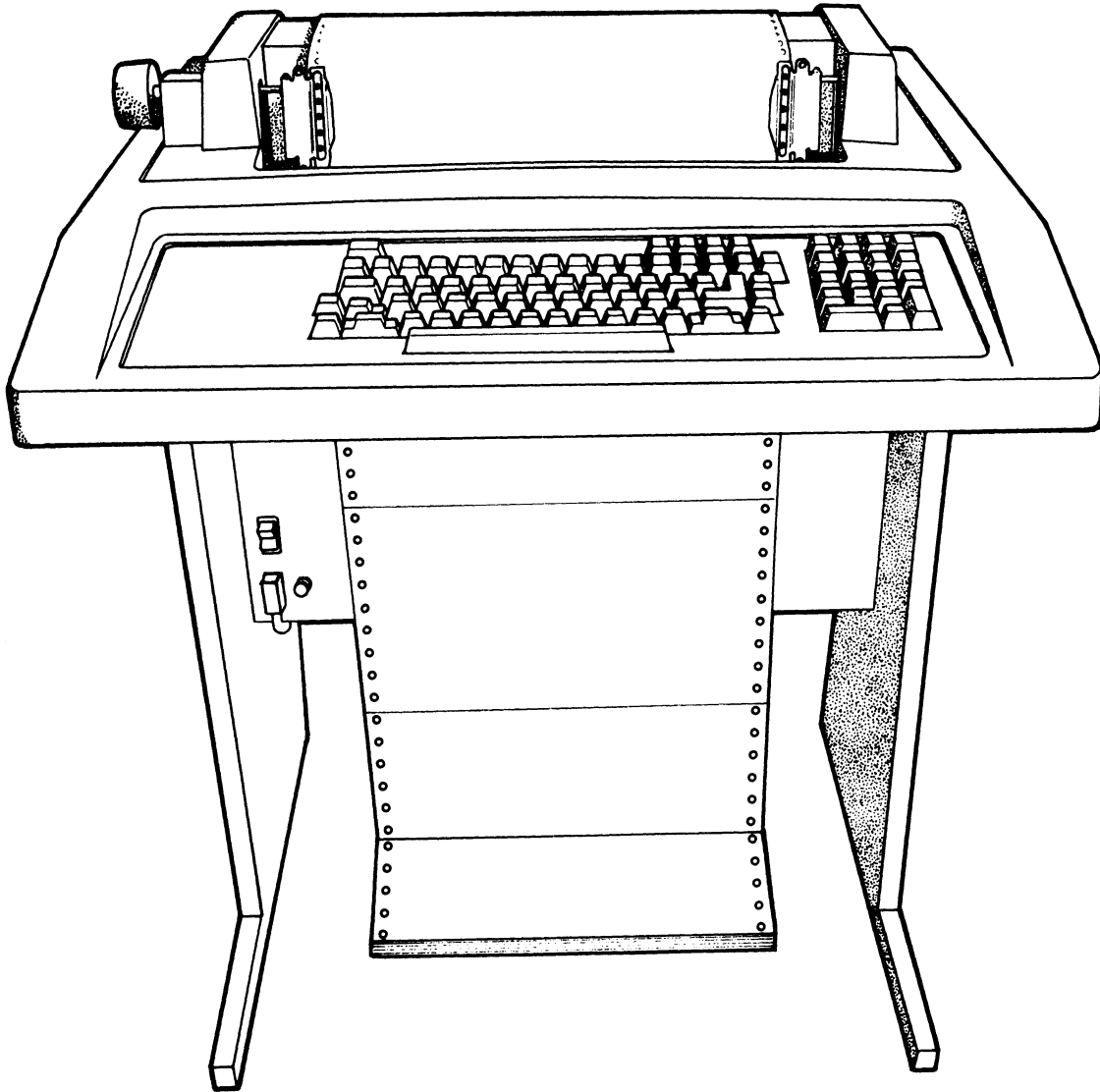

MA-2313A

LA120 DECwriter III



# CHAPTER 1 OPERATORS INFORMATION

## 1.1 INTRODUCTION

The LA120 DECwriter III terminal is basically a typewriter, with a wide range of features, that communicates with a computer.

The LA120 is easily integrated into most systems. It is compatible with both EIA and ANSI standards. Besides the many standard features built into the basic LA120 DECwriter III, there are a number of options and accessories that may be added to the terminal to make it useful in an even wider range of applications.

Operator information contained in Chapter 1 is for the general user or user already familiar with the features of a terminal.

It contains the following information:

- Description of operator's console
- Description of alarm indicators
- Operator Testing and troubleshooting.

Operator information is summarized on the LA120 Operator Reference Card (Appendix A). Table 1-1 is a list of related LA120 documents.

**Table 1-1 Related Documentation**

<b>Title</b>	<b>Document Number</b>
LA120 User Guide	EK-LA120-UG*
LA120 Pocket Service Guide	EK-LA120-SV*
LA120 DECwriter III Illustrated Parts Breakdown	EK-LA120-IP**

\*Available on hard copy only.

\*\*Available on hard copy and microfiche.

For information on microfiche libraries, contact:

Digital Equipment Corporation  
Micropublishing Group  
12 Crosby Drive  
Bedford, MA 01730

Hardcopy documents can be ordered from:

Digital Equipment Corporation  
444 Whitney Street  
Northboro, MA 01532  
Attention: Communication Services (NR2/M15)  
Customer Services Section

## 1.2 OPERATOR'S CONSOLE (Figure 1-1)

The LA120 operator's console contains an office typewriter-style keyboard. The keyboard contains a four-digit numeric display and seven indicators. There is provision for an optional, field installable numeric keypad.

To better understand the LA120 keyboard, think of the LA120 as two things. First, it is an input device to a computer; that is, pressing a key sends information (a code) to a computer. Second, it is a printer; information is sent from the computer to the printing portion of the LA120. However, you can set up your system to send information from the keyboard to the printer and computer at the same time. Figure 1-2 illustrates a basic system using an LA120.

### 1.2.1 Lights

The console indicator lights are listed in Table 1-2.

**Table 1-2 LA120 Console Indicators**

Indicator Light	Meaning
ON LINE	The LA120 is on-line. Data is transmitted and received only while on-line.
LOCAL	The LA120 is in local mode. In local, LA120 operates as a typewriter and does not transmit or receive data.
ALT CHAR SET	An optional alternate character set such as APL is in use.
CTS	Transmission of data is enabled (clear to send).
DSR	The modem is in data mode (data set ready).
SET-UP	Flashes to indicate that LA120 is in SET-UP mode.
PAPER OUT	Flashes to indicate that printer is not ready due to any of the following conditions. <ul style="list-style-type: none"><li>• Paper out</li><li>• Cover open</li><li>• Print head jam</li></ul>
NUMERIC DISPLAY	The numeric display indicates the next column number during normal operation. In SET-UP mode the numeric display may also indicate line number, baud rate, form length, etc.

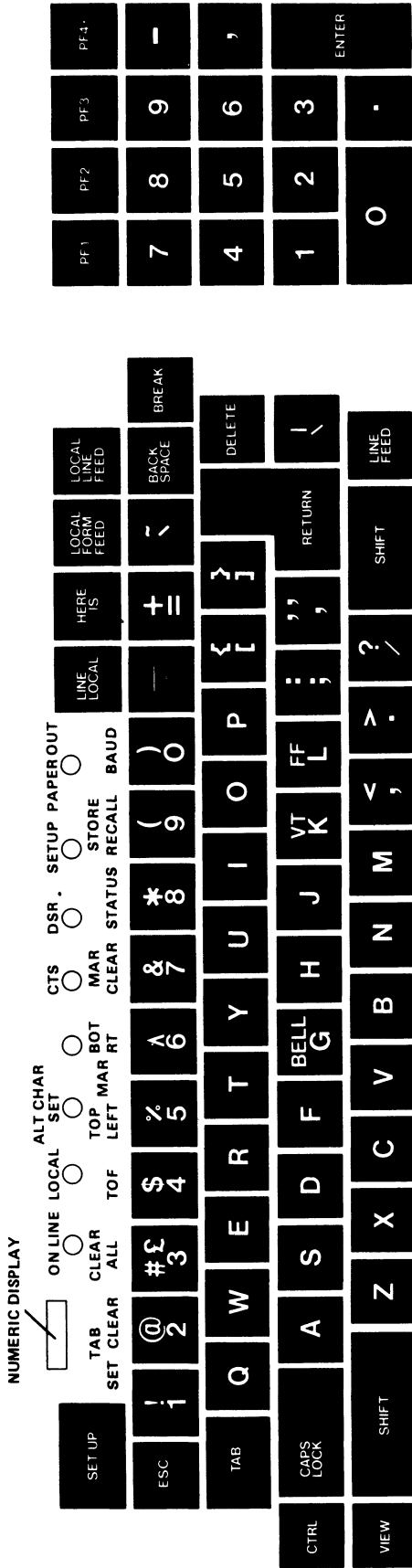

MA3364

Figure 1-1 Operator's Console

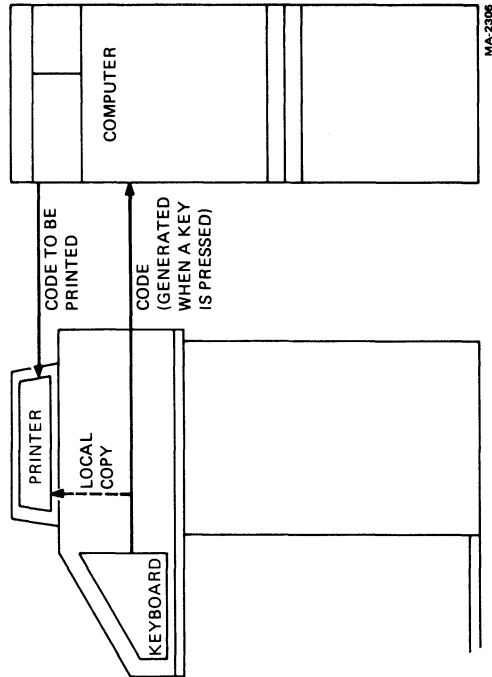

Figure 1-2 Basic System Using LA120

### 1.2.2 Local Control Keys

The console local control keys and their functions are listed in Table 1-3.

**Table 1-3 LA120 Console Local Control Keys**

Key	Function
LINE/LOCAL	Switches the LA120 from line to local and vice versa as indicated by ON LINE and LOCAL lights.
HERE IS	Transmits answerback message. This key is not active in SET-UP mode.
LOCAL FORM FEED	Performs a form feed without transmitting a code to the host computer.
LOCAL LINE FEED	Advances paper one line at a time without transmitting a code to host computer.

### 1.2.3 SET-UP Keys

When in SET-UP mode, most keys on the console keyboard perform a SET-UP command function. SET-UP command functions for the top row of keys are discussed briefly in Table 1-4.

**Table 1-4 LA120 Console Set-Up Keys**

Key	Label	Function
SET-UP	-	Places LA120 in SET-UP mode where LA120 features can be examined or changed. In SET-UP mode, the numeric display indicates line number, baud rate, or form length, etc.
!	SET TAB	Sets a horizontal tab stop at the current column. When used with SHIFT, sets a vertical tab stop at current line.
1		
^		
6	BOT/RT MAR	Sets right margin at current column. When used with SHIFT, sets bottom margin at current line.
@	CLEAR TAB	Clears horizontal tab stop at current column. When used with SHIFT, clears vertical tab stop at current line.
2		
/#£	CLEAR ALL	Clears all horizontal and vertical tab stops.
3		
\$	TOF	Shifted or unshifted designates current paper position as top of form. If top of form is not the same as the top margin, paper will move to the top margin (first printable line).
4		
&	MAR CLEAR	Clears left and right margins. When used with SHIFT, clears top and bottom margins. Left or top margin becomes ]. Right or bottom margin becomes maximum allowable in the current characters per inch (pitch) or form length.
7		

**Table 1-4 LA120 Console Set-Up Keys (Cont)**

Key	Label	Function
* 8	STATUS	Prints a status message containing currently selected values of SET-UP features.
( 9	STORE/RECALL	Recalls stored SET-UP parameters. When used with SHIFT, stores the current SET-UP parameters.
% 5	TOP/LEFT MAR	Sets left margin at current column. When used with SHIFT, sets top margin at current line.
) 0	BAUD	Selects receive and transmit baud rates. When used with SHIFT, selects split transmit baud rates.

#### 1.2.4 Control Character Keys

The console control character keys and their functions are listed in Table 1-5.

**Table 1-5 LA120 Console Control Character Keys**

Key	Function
ESC	Generates code for escape (Chapter 3).
TAB	Generates code for horizontal tab.
SPACE BAR	Generates code for space.
BACK SPACE	Generates code for backspace.
DELETE	Generates code for delete.
RETURN	Generates code for carriage return or the codes for a carriage return and line feed sequence (in auto line feed mode). In half duplex, the RETURN key can also generate a turnaround character in addition to its normal code or codes. The turnaround character tells the computer that it is the computer's turn to send data.
LINE FEED	Generates code for line feed.
CTRL	When held down, modifies function or codes generated by other keys.
BELL G	Hold CTRL down and press G to generate code for the bell. G is also used in SET-UP mode to change bell volume.
VT K	Hold CTRL down and press K to generate code for vertical tab. K is also used in SET-UP mode to turn keyclick on or off.
FF L	Hold CTRL down and press L to generate code for form feed. L is also used in SET-UP mode to select auto line feed.

### 1.2.5 Other Keys

Other miscellaneous console keys and their functions are listed in Table 1-6.

**Table 1-6 LA120 Console Miscellaneous Keys**

<b>Key</b>	<b>Function</b>
SHIFT	Functions the same as the shift key on a typewriter. When in SET-UP mode, SHIFT can also be used with other keys to select LA120 features.
CAPS LOCK	Causes alphabetic keys to transmit shift (uppercase characters) codes, regardless of the position of the SHIFT key. CAPS LOCK does not affect numeric or other keys.
BREAK	Causes LA120 to transmit a short break signal (233 ms). When used with SHIFT, causes LA120 to transmit a long break disconnect signal (3.5 seconds).
VIEW	Allows operator to view last character printed.

### 1.2.6 Optional Numeric Keypad

The numeric keypad allows numbers to be entered in adding machine fashion. Each number key, minus key, and comma key, normally generate the same codes as the corresponding unshifted keys on the main keyboard. The SHIFT key does not affect the numeric keypad.

In the alternate keypad mode, the keys generate escape sequences that may have special meanings (Chapter 3). The PF1, PF2, PF3, and PF4 keys generate escape sequences that may have special meanings (Chapter 3). The ENTER key normally corresponds to the RETURN key. In alternate keypad mode, ENTER generates an escape sequence that may have a special meaning (Chapter 3).

### 1.2.7 Power ON/OFF Switch and Voltage Selector Switch

The power switch controls power application to the LA120. The switch is located on the LA120 lower front panel (Figure 1-3a). Terminals currently being manufactured also contain a voltage selector switch. The voltage selector switch is located above the power ON/OFF switch. Place the tip of a pen into the selector switch indentation and select the appropriate voltage, as shown in Figure 1-3b.

#### **CAUTION**

**Failure to set the switch to 230 V when plugging the LA120 into a 180–256 V power source will damage the power supply.**

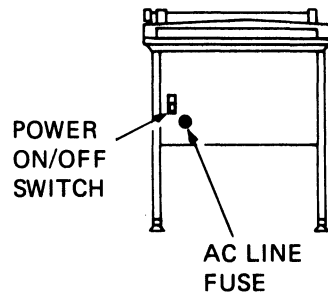

a. Power ON/OFF Switch

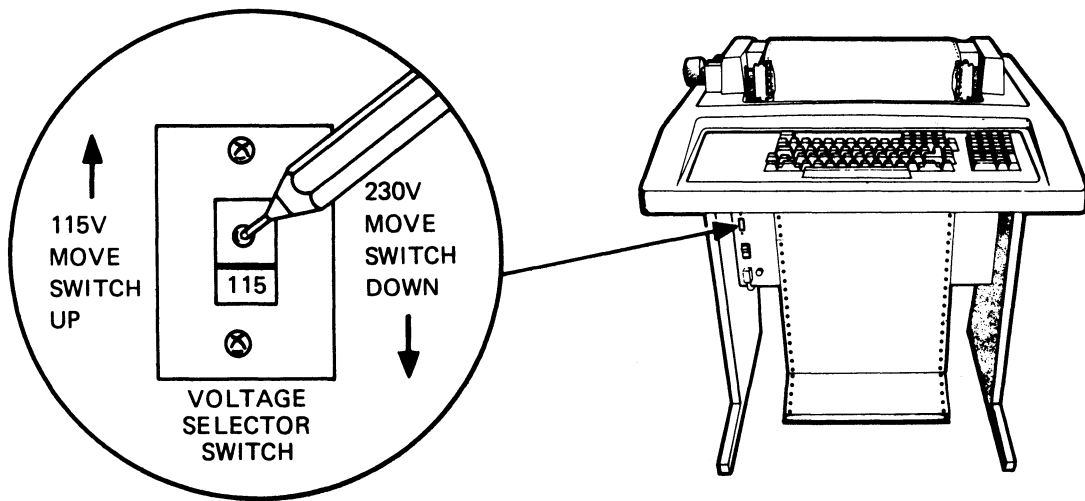

b. Voltage Selector Switch  
(Newer Terminals Only)

MA-4506

Figure 1-3 Location of Power ON/OFF Switch and Voltage Selector Switch

### 1.2.8 Cover Interlock Switch

This switch is a safety feature that prevents operation of the LA120 when the cover is open. The location of the switch is shown in Figure 1-4.

### 1.2.9 Paper Adjust Knob (Figure 1-5)

The paper adjust knob advances the paper 1/12 of an inch at a time. Pressing in and turning the paper adjust knob enables the paper to be rolled freely in either direction and allows precise vertical forms positioning.

#### NOTE

**This knob should only be used when setting up the form. To advance paper, use LOCAL LINE FEED or LOCAL FORM FEED.**

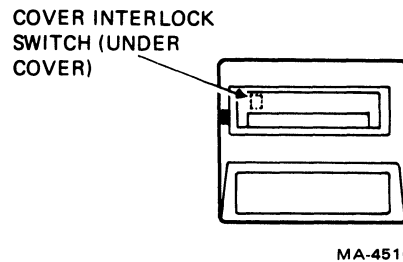

Figure 1-4 Location of Cover Interlock Switch

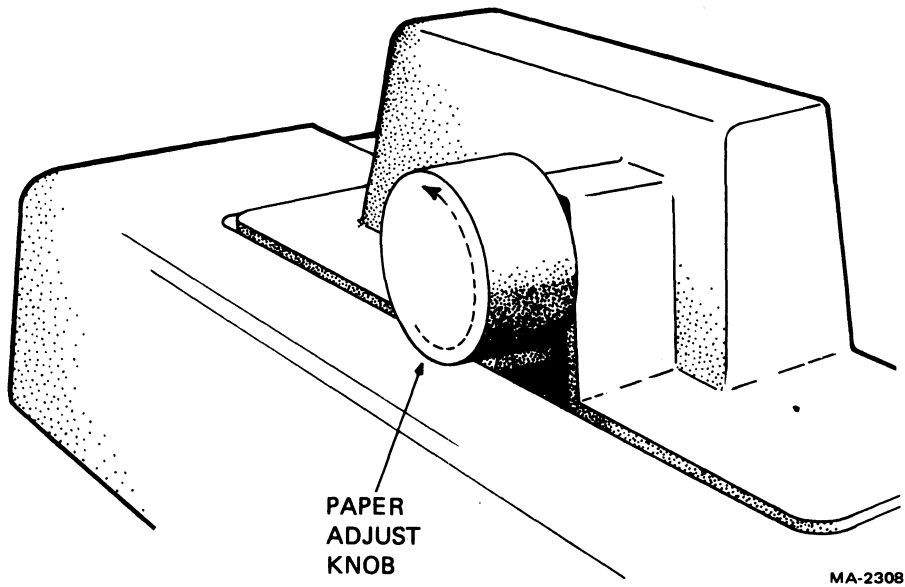

Figure 1-5 Paper Adjust Knob



**1.2.10 Tractor Adjust Knobs (Figure 1-6)**

The tractor adjust knobs allow fine horizontal adjustment of forms.

**1.2.11 Carriage Adjustment Lever (Figure 1-7)**

The carriage adjustment lever controls the print head gap for single or multipart forms.

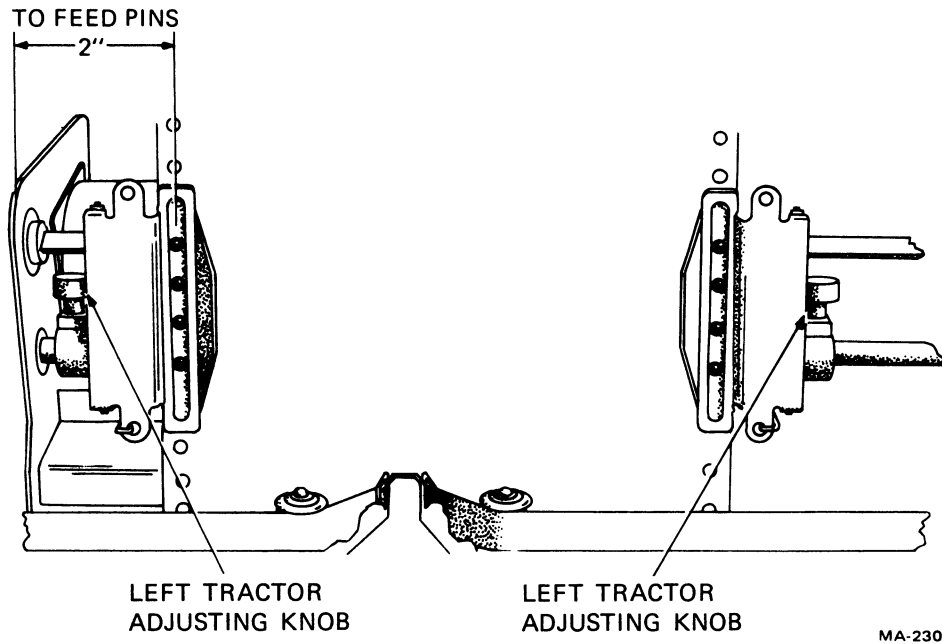

Figure 1-6 Tractor Adjust Knobs

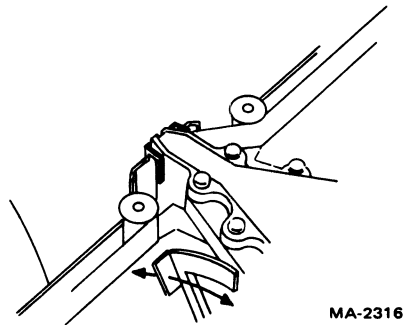

Figure 1-7 Carriage Adjustment Lever

### 1.3 ALARM INDICATORS

The LA120 produces several different alarm and bell signals. The operator should become familiar with these signals to determine the correct response. Table 1-7 lists the various types of alarms, the causes, and the corrective action that should be taken.

**Table 1-7 Alarm Indicators**

Indicator	Cause	Action/Comments
Bell and Flashing PAPER OUT	<p>Paper out</p> <p>Head Jam</p> <p>Cover open</p>	<p>Load paper. Printer will resume normal operation after paper is loaded and cover is closed.</p> <p style="text-align: center;"><b>NOTE</b></p> <p style="text-align: center;"><b>When out of paper, bell will turn off after 5 seconds. If PAPER OUT light continues to flash after cover is closed, paper fault still exists.</b></p> <p>Open top cover and clear obstruction causing head jam (see Operator Troubleshooting, Table 1-9). Reload paper by aligning perforation with print head line indicator. Close cover.</p> <p>(Flashing light only.) Close cover.</p>
Bell only (Low Pitch Bell Tones)	<p>Keyboard buffer overflow</p> <p>Input buffer overflow</p>	<p>Typing faster than the communication line can handle will cause a buffer overflow. This condition is indicated by a bell tone each time a key is pressed. Under these conditions, data will <i>not</i> be lost.</p> <p>Inputs to LA120 faster than 1200 baud (without XON/XOFF or its equivalent) can cause a buffer overflow. This condition is indicated by a bell tone, a special symbol printout, and loss of data.</p>
Bell only (High Pitch Bell Tones)	<p>Approaching right margin</p> <p>Bell character</p> <p>Invalid SET-UP command</p> <p>Incorrect entry of answerback message</p>	<p>One bell tone occurs when print head moves to within 10 characters of right margin.</p> <p>Each bell character code received causes a bell tone.</p> <p>One bell tone occurs for each invalid SET-UP command.</p> <p>Attempting to enter more than a 30 character answerback message will cause a bell tone.</p>

#### 1.4 OPERATOR TESTING AND TROUBLESHOOTING

The LA120 automatically runs several internal tests and displays the error test results in the numeric display. Table 1-8 lists the error test results, the cause, and the required corrective action.

**Table 1-8 LA120 Internal Tests**

Test Result	Cause	Corrective Action
0 (flashing)	Error at ROM address 0	Call for service
1 (flashing)	Error at ROM address 2048	Call for service
2 (flashing)	Error at ROM address 4096	Call for service
3 (flashing)	Error at ROM address 6144	Call for service
4 (flashing)	Error at ROM address 8192	Call for service
5 (flashing)	Error at ROM address 10240	Call for service
6 (flashing)	Reserved for future options	-
7 (flashing)	RAM diagnostic failure	Call for service
8 (flashing)	Microprocessor failure	See Note 1
9 (flashing)	Nonvolatile memory failure	See Note 2
8888 (constant)	Cover open	Close cover
	Out of paper	Reload paper

#### NOTES

1. Turn LA120 off, then back on. If an error indication reappears, record indication and call for service.
2. If the original problem was a flashing 9, check stored SET-UP feature to ensure that it has not been affected. The self-test is an additional test (Paragraph 2.1.3) that can be initiated by the operator. The test will help determine if the problem is in the printer or in some other portion of the communication system.
3. If you are unable to turn the printer on or if the printer appears to be faulty, refer to the operator's troubleshooting table (Table 1-9). This table describes those things an operator can check prior to requesting service.

**Table 1-9 Operator Troubleshooting**

Symptom	Possible Cause and Corrective Action
LA120 does not turn on when printer power switch is set to ON.	<p>AC power cord is not plugged into wall outlet or front of printer. Plug in cord.</p> <p>Power is not coming from wall outlet. Check outlet with a known working electrical device (such as a lamp). If no power, call maintenance personnel.</p> <p>AC line fuse blown; turn printer off and replace fuse (Figure 1-3).</p>

**Table 1-9 Operator Troubleshooting (Cont)**

<b>Symptom</b>	<b>Possible Cause and Corrective Action</b>
Characters do not print	<p>Printer out of paper; load paper. (See <i>LA120 User Guide</i> for paper loading.)</p> <p>Printer cover open or ajar. Close cover.</p> <p>Print head too far from paper; readjust carriage adjustment lever. (See Paragraph 1.2.11 for adjustment.)</p> <p>Data set unplugged; plug it in.</p> <p>Incorrect communication setup.</p>
Light print	<p>Print head too far from paper; readjust carriage adjustment lever.</p> <p>Ribbon out of ink; turn ribbon over or replace ribbon. (See <i>LA120 User Guide</i> for ribbon replacement.)</p> <p style="text-align: center;"><b>NOTE</b>  <b>Turn ribbon over after 5 to 6 hours of continuous printing. Ribbon can be turned over only once; then it must be replaced.</b></p>
Paper does not advance	<p>Paper not loaded properly; check that tractor covers are closed and feed holes are aligned properly.</p> <p>Feed holes torn; reload paper. If paper falls against tractor pins or bows in the middle, readjust right tractor.</p>
Paper tearing on multipart forms	<p>Print head exerting too much pressure on paper; readjust carriage adjustment lever.</p> <p>Tractor incorrectly adjusted. If paper pulls against tractor pins or bows in the middle, readjust right tractor.</p> <p>Paper not straight in printer; realign paper.</p>
Print head jam or print head does not move	<p>Paper or print head jam; clear jam and perform reloading paper/form procedure. (See <i>LA120 User Guide</i>.)</p>
No keyboard or printer	<p>Printer cover open or ajar when printer is turned on (normally indicated by flashing 8888 and PAPER OUT light); close the cover.</p>
Garbled or double characters.	<p>Incorrect communication setup. Ensure that communication setup is compatible with the equipment at the other end of the line.</p>

## CHAPTER 2 INSTALLATION, INTERFACE, AND SPECIFICATIONS

### 2.1 INSTALLATION AND CONFIGURATION

This section contains step-by-step procedures for unpacking, cabling, and unit checkout to ensure that the unit was not damaged during shipment and that the unit is operating properly prior to connection to the communication system.

The LA120 should be installed in an area that is free of excessive dust, dirt, corrosive fumes, and vapors. To ensure that the unit has proper ventilation and cooling, ventilation openings on the side of the cabinet should not be obstructed.

A minimum 4-inch clearance between units must be maintained at all times. Figure 2-1 illustrates site considerations.

#### NOTE

Site plans are not supplied by Digital Equipment Corporation.

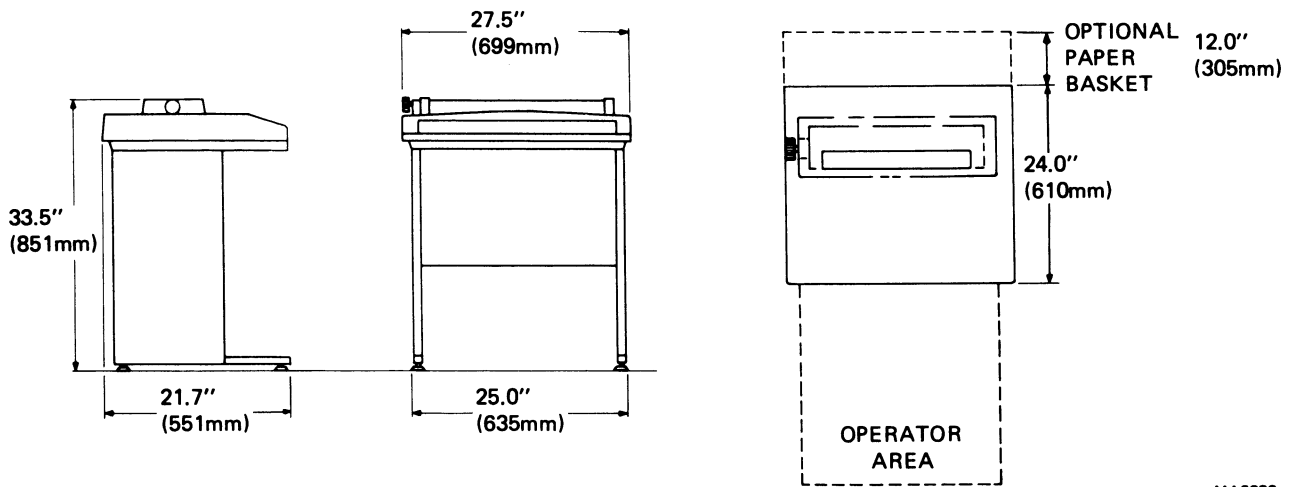

MA3383

Figure 2-1 LA120 Site Considerations

### 2.1.1 Unpacking and Inspection

1. Cut nylon retaining straps from around the shipping carton and discard them.
2. Remove outer cardboard shipping container.
3. Remove all shock-absorbing material and packing from around the LA120 (Figure 2-2).
4. Loosen and remove hex-head bolts that secure wood leg brace to skid assembly. Remove microfoam around each leg of the LA120.
5. Carefully inspect LA120 cabinet and carriage assembly for possible shipping damage. Inspect and check enclosed packing list for lost or missing items. Report any damaged or missing items to the local DIGITAL Field Service or Sales Office and local carrier.
6. Remove printer from wooden shipping skid and place it in desired location.
7. Install and adjust leveling feet on LA120 legs.
8. Lift LA120 top cover assembly. Clip and remove nylon cable tie securing print head assembly (Figure 2-3).
9. If necessary, wipe all outer surfaces with a clean, soft, lint-free cloth.
10. Connect EIA interface cable to user's equipment.
11. The LA120 SET-UP label is enclosed in the package with the user guide. Fasten label to area shown in Figure 2-4.

#### NOTE

**To install 20 mA option, refer to Chapter 8. Interface logic connections must be specified and provided by the system supplier or the customer as each installation may differ.**

### 2.1.2 Packing Procedures

If it is necessary to ship your LA120 to another location, repack it per the following procedure.

1. Remove ribbon and paper.
2. Use a nylon cable tie to secure print head assembly (Figure 2-3). This prevents movement during transit.
3. Pack LA120 as shown in Figure 2-2.

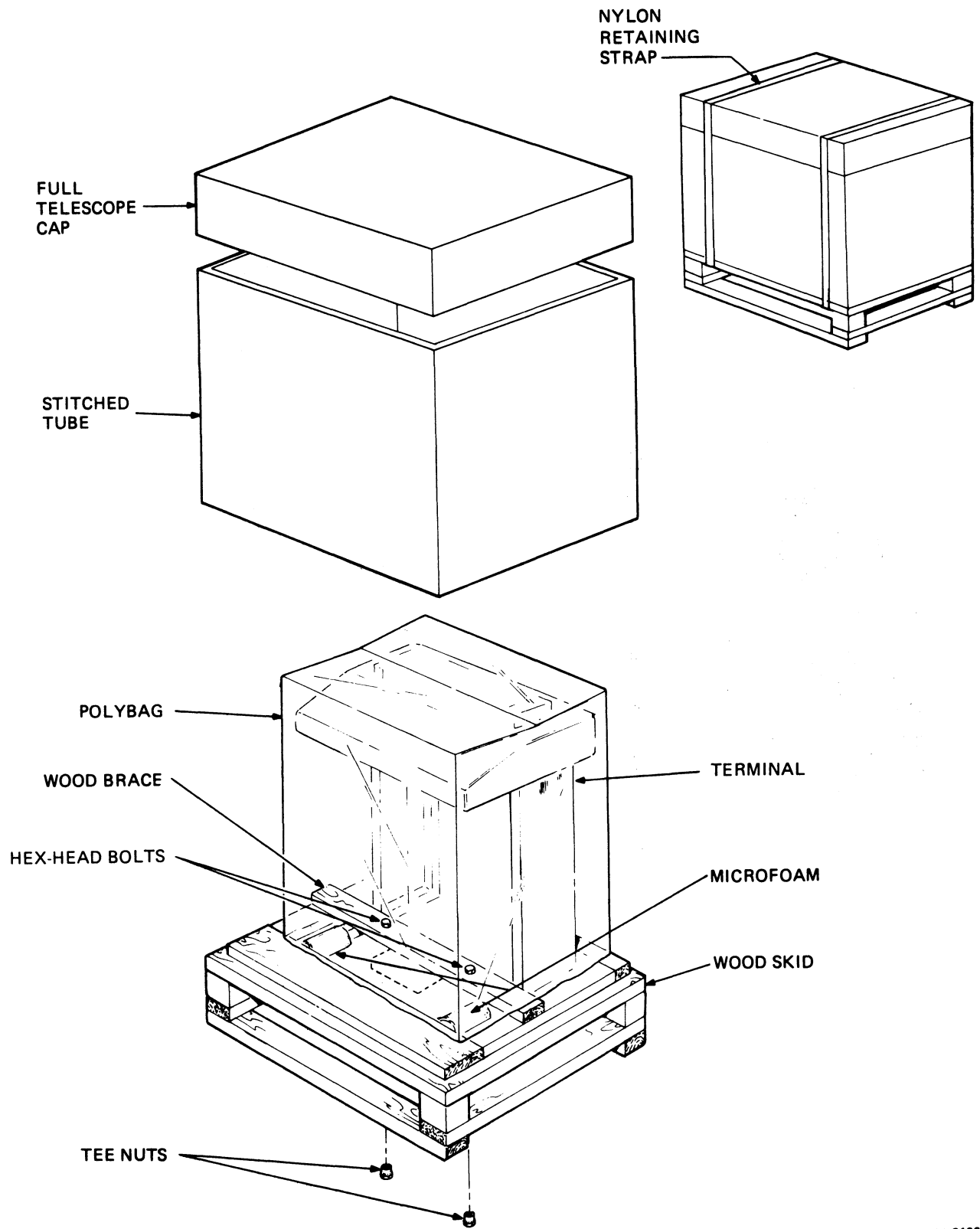

MA-3166

Figure 2-2 Unpacking/Packing

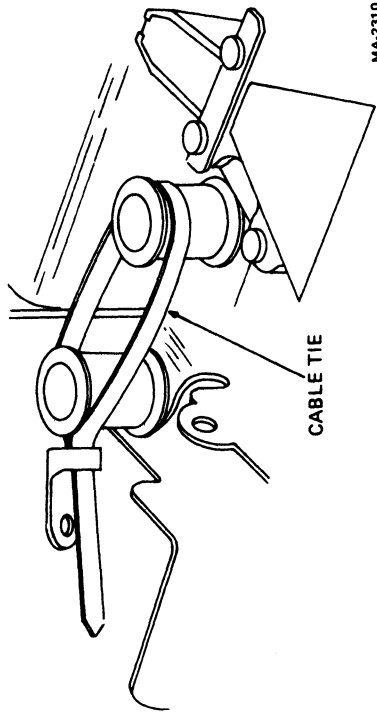
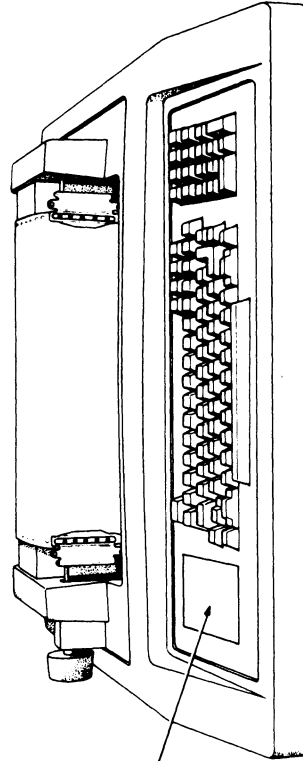

Figure 2-3 Location of Nylon Cable Tie



MA-2307

Figure 2-4 Location of LA120 SET-UP Label

REC	Receive baud rate	0 = Off	1 = On
XMT	Transmit baud rate	0 = Small	1 = Large
A	Auto-answerback	1 = US	2 = GB
B	Buffer control	0 = Off	1 = On
C	Printer char. set	0 = Off	1 = On
D	Auto-disconnect	0 = Off	1 = On
E	Local echo	0 = Off	1 = On
F	Form length	0 = low	1 = High
G	Bell volume	0 = low	1 = High
H	Horizontal pitch	Char. per inch	
I	Auto-newline	0 = Off	1 = On
J	Key click	0 = Off	1 = On
K	Auto-linefeed	0 = Off	1 = On
L	Modem/protocol	1 = US	2 = GB
M	Keyboard char. set	0 = Off	1 = On
N	Alt. char. set	0 = Off	1 = On
O	Parity/data bits	0 = XMT	1 = REC
P	HDX initial state	0 = Off	1 = On
Q	Auto-repeat	0 = No	1 = Yes
R	Secondary channel	0 = No	1 = Yes
S	Break enable	0 = No	1 = Yes
U	Vertical pitch	Lines per inch	
V	XON/XOFF	1 = None	2 = LF 3 = CR
W	Printer NL char.	0 = Mb	1 = Yes
X	Alt keypad mode	0 = No	1 = Yes
Y	Auto-view	0 = Off	1 = On
Z	Initialize to factory settings	0 = Off	1 = On
I	Self test:	Type a character to stop	
T			



### 2.1.3 Checkout Procedure

The checkout procedure consists of running the self-test exercise. Two self-tests are provided. One prints out characters within the currently selected margins; the other causes the LA120 to go through the same motions as the printing test, but without printing. Use the nonprinting self-test if your printer is loaded with valuable forms such as checks or tickets.

To perform the checkout, proceed as follows.

1. Install ribbon and paper. (Refer to *LA120 User Guide* for ribbon and paper installation procedure.)
2. The LA120 terminal may have a voltage selector switch located above the power ON/OFF switch. If so, place the tip of a pen into the selector switch indentation and select the appropriate voltage (Figure 1-3b).

#### CAUTION

**Failure to set the switch to 230 V when plugging the LA120 into a 180–256 V power source will damage the power supply.**

3. Connect LA120 line cord to correct wall receptacle.

#### CAUTION

**Before connecting LA120 to a power source, ensure that power switch is OFF and line voltage and frequency are compatible with machine power requirements.**

4. Set power switch to ON. Print head automatically positions itself to the left margin.
5. Enter SET-UP mode. SET-UP light flashes to indicate you are in SET-UP mode.
6. Press T to initiate a printing self-test. LA120 prints out self-test pattern (Figure 2-5).

#### NOTE

**To run a nonprinting self-test, do not press T. Instead, press and hold SHIFT and press >. The LA120 will perform a nonprinting self-test.**

7. To stop test, exit SET-UP mode or press any character. Self-test terminates.
8. Exit SET-UP mode. SET-UP light stops flashing.

```

.,-./0123456789:;<=>?@ABCDEFGHIJKLMN0PQRSTUVWXYZ[\
--./0123456789:;<=>?@ABCDEFGHIJKLMN0PQRSTUVWXYZ[\]
./0123456789:;<=>?@ABCDEFGHIJKLMN0PQRSTUVWXYZ[\]^
/0123456789:;<=>?@ABCDEFGHIJKLMN0PQRSTUVWXYZ[\]^_
'0123456789:;<=>?@ABCDEFGHIJKLMN0PQRSTUVWXYZ[\]^_`
)123456789:;<=>?@ABCDEFGHIJKLMN0PQRSTUVWXYZ[\]^_`a
.23456789:;<=>?@ABCDEFGHIJKLMN0PQRSTUVWXYZ[\]^_`ab
!3456789:;<=>?@ABCDEFGHIJKLMN0PQRSTUVWXYZ[\]^_`abc
$456789:;<=>?@ABCDEFGHIJKLMN0PQRSTUVWXYZ[\]^_`abcd
!56789:;<=>?@ABCDEFGHIJKLMN0PQRSTUVWXYZ[\]^_`abcde
!6789:;<=>?@ABCDEFGHIJKLMN0PQRSTUVWXYZ[\]^_`abcdef
!789:;<=>?@ABCDEFGHIJKLMN0PQRSTUVWXYZ[\]^_`abcdefg

```

MA-4695

Figure 2-5 Self-Test Printout

### 2.1.4 Answerback Jumper

To obtain a permanent answerback message that cannot be changed by the operator, remove the jumper shown in Figure 2-6.

#### NOTE

The answerback message must be stored in permanent memory prior to removing the jumper. When the jumper is removed, the answerback message cannot be altered or erased.

To remove the jumper, proceed as follows.

1. Store answerback message, if required.
2. Verify answerback message.
3. Turn power off.
4. Remove jumper.
5. Turn power on.

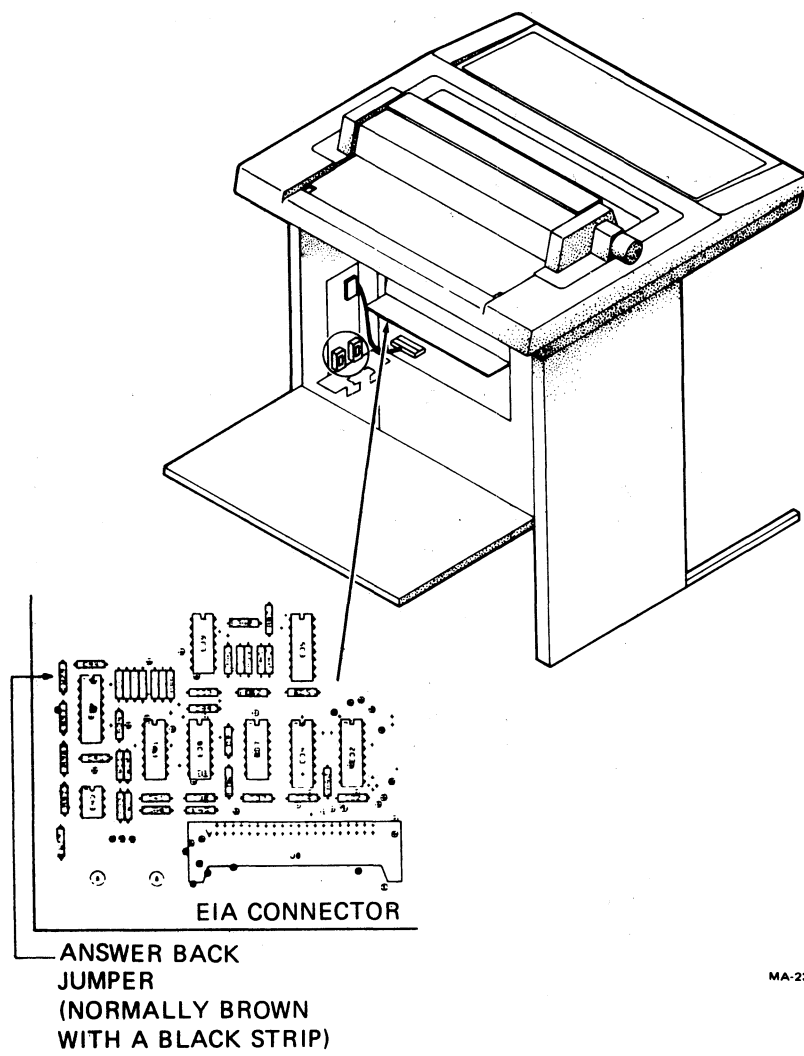

Figure 2-6 Location of Answerback Jumper

## 2.2 INTERFACE INFORMATION

The LA120 interfaces with EIA devices using an optional modem cable. The interface is compatible with Bell 103, 212A, and 202 modems and meets EIA specification RS232-C requirements. The interface conforms to CCITT recommendation V.2.4.

### 2.2.1 Interface Signals

Table 2-1 summarizes EIA interface signals. The following paragraphs describe interface signals.

**2.2.1.1 Protective Ground** – This conductor is connected to the LA120 chassis. It is further connected to external grounds through the third wire of the power cord.

**2.2.1.2 Transmitted Data (TDX)** – The direction of TDX is from the LA120. Signals on this circuit represent serially encoded characters generated by the LA120.

**2.2.1.3 Received Data (RDX)** – The direction of RDX is to the LA120. Signals on this circuit represent serially encoded characters generated by the user's equipment.

**Table 2-1 Summary of LA120 EIA Interface Signals**

Pin	Source	Name	Function	Circuit CCITT/EIA
1	-	-	Protective ground	101/AA
2	LA120	TXD	Transmitted data	103/BA
3	User	RXD	Received data	104/BB
4	LA120	RTS	Request to send	105/CA
5	User	CTS	Clear to send	106/CB
6	User	DSR	Data set ready	107/CC
7	-	-	Signal ground	102/AB
8	User	RLSD	Carrier detect	109/CF
9	-	-	-	-
10	-	-	-	-
11*	LA120	SRTS	Sec. req. to send	120/SCA
12†	User	SPDI	Speed indicator (FDX)	112/CI
	User	SRLSD	Sec. carrier det. (HDX)	122/SCF
13	-	-	-	-
14	-	-	-	-
15	-	-	-	-
16	-	-	-	-
17	-	-	-	-
18	-	-	-	-
19*	LA120	SRTS	Sec. req. to send	120/SCA
20	LA120	DTR	Data term. ready	108.2/CD
21	-	-	-	-
22	User	RI	Ring indicator	125/CE
23*	LA120	SPDS	Speed select (FDX)	111/CH
24	-	-	-	-
25	-	-	-	-

\* Pins 11, 19, and 23 are driven by a common circuit whose function is determined by the modem and secondary channel SET-UP commands.

† Pin 12 is SPDI for full-duplex operation. For half-duplex operation, pin 12 is SRLSD.

**2.2.1.4 Request To Send (RTS)** – The direction of RTS is from the LA120. The on condition of RTS means that the LA120 intends to transmit data. After turning this circuit on, the LA120 waits for a clear to send (transmit enable) condition before starting transmission.

**2.2.1.5 Clear To Send (CTS)** – The direction of CTS is to the LA120. Although the LA120 physically receives this signal, it is not used for any purpose. Depending on the modem control protocol in use, either RLSD, SRLSD, or a timeout after asserting RTS is used to provide a clear to send (transmit enable) condition.

**2.2.1.6 Data Set Ready (DSR)** – The direction of DSR is to the LA120. The on condition of DSR indicates that the user's equipment is capable of transmitting and receiving data signals. The off condition of DSR causes the LA120 to ignore all other interface inputs except ring indicator (RI). In full duplex without EIA control, this circuit is assumed to always be in the on condition.

**2.2.1.7 Signal Ground** – This circuit establishes the common ground reference potential for all interface circuits except protective ground. The circuit is permanently connected to the protective ground circuit.

**2.2.1.8 Carrier Detect (RLSD)** – The direction of RLSD is to the LA120. The on condition of RLSD indicates that data transmission from the user's equipment to the LA120 is enabled. In full duplex without EIA control, this circuit is assumed to always be in the on condition.

**2.2.1.9 Secondary Request To Send (SRTS)** – The direction of SRTS is from the LA120. In certain half-duplex modes, the on condition of SRTS indicates that the LA120 is capable of successfully processing the received data from the user's equipment. In restraint mode, the off condition of SRTS indicates that the user's equipment should temporarily suspend the transmission of data. When SRTS goes on, transmission may be resumed.

**2.2.1.10 Speed Indicator (SPDI) (Full Duplex Only)** – The direction of SPDI is to the LA120. The on condition of SPDI indicates that the baud rate is 1200, regardless of the rate selected by the operator. The off condition indicates that the operator-selected baud rate is being used.

**2.2.1.11 Secondary Carrier Detect (SRLSD) (Half Duplex Only)** – The direction of SRLSD is to the LA120. The on condition of SRLSD indicates that the user's equipment is capable of successfully processing the transmitted data from the LA120.

**2.2.1.12 Data Terminal Ready (DTR)** – The direction of DTR is from the LA120. The on condition of DTR indicates that the LA120 is capable of transmitting and receiving data signals. The off condition of DTR may cause the user's equipment to set the DSR (data set ready) to the off condition. When DTR is off, the LA120 ignores all interface inputs except ring indicator (RI).

**2.2.1.13 Ring Indicator (RI)** – The direction of RI is to the LA120. If data terminal ready (DTR) is off, then the on condition of RI causes DTR to turn on. DTR remains on until data set ready (DSR) turns on or 30 seconds elapses, whichever occurs first. Then DTR turns off. If DTR is on, the on condition of RI causes a 30-second timeout. If no data is received in 30 seconds, DTR is pulsed low for 233 ms  $\pm$  10 percent.

**2.2.1.14 Speed Select (SPDS) (Full Duplex Only)** – The direction of SPDS is from the LA120. If the operator-selected baud rate is 600 or higher, the LA120 asserts an on condition of SPDS; otherwise, the LA120 holds this circuit in the off condition.

## **2.2.2 EIA Interface Cables**

BC22A and BC22B interface cables are described in the following paragraphs.

**2.2.2.1 BC22A-10, -25** – BC22A interface cables come in 10 and 25 foot lengths for hookup between LA120 and computer.\* Each end is terminated with a female molded connector. The cable is shielded, contains six conductors, and is wired in a null modem configuration.

**2.2.2.2 BC22B-10, -25** – BC22B interface cables come in 10 and 25 foot lengths for hookup between LA120 and modem.† They can also be used for cable extension. Connectors are molded with a male connector at one end and a female at the other end. Cable is shielded and has 14 conductors.

**2.2.3 Impedance of Terminator**

The terminating impedance of the receiving end of the interface circuits has a dc resistance of not less than 3000 ohms or more than 7000 ohms. When the interface plug is disconnected, interface voltage on the terminator circuits is -2 V to +2 V.

**2.2.4 Rise and Fall Times**

The circuitry that receives signals from an interface circuit depends only on signal voltage and conforms to RS232-C rise time and fall time. For control interface circuits, the time required for the signal to pass through the transition region (-3 V to +3 V) during a change in state does not exceed 1  $\mu$ s. For the transmitted data circuit, the rise time and fall time do not exceed 16.7  $\mu$ s through the 6 V range (-3 V to +3 V).

**2.2.5 Open Circuit Voltages**

The open circuit driver voltage for signal ground on any interface circuit does not exceed -12 V to +12 V. The terminator on an interface circuit is designed to withstand any input signal within a -25 V to +25 V range. When the terminating impedance is in the proper range (3000 to 7000 ohms) and the terminator open circuit voltage is zero, the potential at the point of interface is not less than -5 V to +5 V or more than -12 V to +12 V. An open circuit or applied voltage more negative than +0.6 V will be interpreted the same as a legitimate negative voltage (-3 V to -25 V).

**2.3 LA120 SPECIFICATIONS**

The LA120 specifications include data on the printer, keyboard, communications, physical aspects, and paper. The data in each of these categories is given in Tables 2-2 through 2-6.

**Table 2-2 Printer Specifications**

Item	Specification
Printing technique	Impact dot matrix, smart bidirectional
Print matrix (width by height)	7 × 7
Maximum print speed	180 char/s
Horizontal slew speed	60 in/s
Single line feed time	33 ms
Vertical slew speed	7.5 in/s

\*For longer lengths, use BC03M instead of BC22A. Specify desired length.

†For longer lengths or full 25 connectors, use BC05D instead of BC22B. Specify desired length.

**Table 2-2 Printer Specifications (Cont)**

<b>Item</b>	<b>Specification</b>
Paper feed	Pin-feed, tractor drive
Paper type	Fanfold, up to six parts (Table 2-6)
Forms length	1 to 168 lines
Vertical pitch (lines per inch)	2, 3, 4, 6, 8, 12
Horizontal pitch (characters per inch)	
180 char/s	10, 12, 13.2, 16.5
90 char/s	5, 6, 6.6, 8.25
Maximum line length (varies with horizontal pitch)	
5 char/in	66 columns
6 char/in	79 columns
6.6 char/in	87 columns
8 char/in	108 columns
10 char/in	132 columns
12 char/in	158 columns
13.2 char/in	174 columns
16.5 char/in	217 columns
Margins	Left, right, top, bottom
Tabs	217 horizontal, 168 vertical, from keyboard or line
Forms storage	True non-volatile memory (no batteries)
Positioning commands	Horizontal and vertical, absolute and relative
Character set	ASCII upper/lowercase set
National character sets	
Standard	United States Great Britain
Optional	Finland Sweden Norway Denmark Germany France
APL character set	Optional

**Table 2-2 Printer Specifications (Cont)**

<b>Item</b>	<b>Specification</b>
Other printer features	<ul style="list-style-type: none"><li>• Paper out and cover open interlocks</li><li>• Manual and automatic last character view</li><li>• Selectable auto new line</li><li>• Self-test</li><li>• Status message</li><li>• Four-digit numeric display used as column counter and to set parameters</li><li>• Factory stored form setup (10 char/in, 6 lines/in, 66 lines/form; tab stops every eight columns, etc.)</li></ul>

**Table 2-3 Keyboard Specifications**

<b>Item</b>	<b>Specification</b>
Keyboard	Typewriter style with multikey rollover
Selectable auto line feed	Standard
Optional numeric keypad	18 keys including 4 function keys
Feature selection	Keyboard entry to non-volatile memory
Other keyboard features	<ul style="list-style-type: none"><li>• Local form feed key</li><li>• Local line feed key</li><li>• Auto repeat on all alphanumeric keys</li><li>• Selectable keyclick</li></ul>



**Table 2-4 Communications Specifications**

<b>Item</b>	<b>Specification</b>
Data transfer	Serial, asynchronous
Baud rates (bits/s)	50, 75, 110, 134, 134.5, 150, 300, 600, 1200, 1800, 2400, 4800, 7200, 9600
Split speeds (bits/s)	<ul style="list-style-type: none"><li>• 600 or 1200 receive, with 75 or 150 transmit</li><li>• 2400 or 4800 receive, with 300 or 600 transmit</li></ul>
Parity	Odd, even, or none (8th bit mark or space transmitted, or data bits only)
Input buffer	1024 characters standard 4096 characters optional
Interface	Full EIA standard (includes auto answer/disconnect) 20 mA optional
Character codes	7-bit ASCII plus ANSI-compatible escape sequences
Modem control protocols	
Full Duplex	Selectable XON/XOFF or restraint signal data synchronization
Half Duplex	Coded control with or without reverse channel
Half Duplex	<ul style="list-style-type: none"><li>• Reverse channel</li><li>• Supervisory</li><li>• Line control</li></ul>
Answerback	Up to 30 characters

**Table 2-5 Physical Specifications**

Item	Specification
Dimensions	
Width	69.9 cm (27.5 in)
Height	85.1 cm (33.5 in)
Depth	61.0 cm (24.0 in)
Weight	
Uncrated	46.4 kg (102 lb)
Crated	63.7 kg (140 lb)
Power	
Voltage	87 to 128 V/180 to 256 V*
Frequency	60/50* Hz $\pm$ 1 Hz
Input current	4.2 A max at 115 V
Heat dissipation	
Printing	440 W maximum
Temperature	
Operating	10° to 40° C (50° to 104° F)
Non-operating	-40° to 66° C (-40° to 151° F)
Relative Humidity	
Operating	10 to 90 percent with a maximum wet bulb temperature of 28° C (82° F) and a minimum dewpoint of 2° C (36° F), noncondensing
Non-operating	5 to 95 percent, noncondensing

\* With voltage selector switch. See Paragraph 2.1.3, Step 2.

**Table 2-6 Paper Specifications**

<b>Item</b>	<b>Specification</b>
General	Continuous, fanfold, pin-feed forms
Width	7.6 to 37.8 cm (3 to 14-7/8 in)
Hole spacing	12.7 mm $\pm$ 0.25 mm (0.500 in $\pm$ 0.010 in) nonaccumulative over 5 cm (2 in)
Hole diameter	3.81 to 4.06 mm (0.150 to 0.160 in)
Forms thickness	
Single part	15 lb paper minimum 0.25 mm (0.010 in) card stock max
Multipart	Up to 6 parts (see Notes) 0.50 mm (0.020 in) max

**NOTES**

1. Multipart forms may have only one card part. The card part must be the last part.
2. Multipart carbonless forms up to six parts may be used. Ribbon must be used on top copy. First-surface impact paper is not recommended.
3. Multipart forms with 3- or 4-prong margin crimps on both margins are recommended. Stapled forms are not recommended and may damage tractors and other areas of machine. Dot or line glue margins are acceptable if line is on one margin only. Line glue on both margins prevents air from escaping and results in poor impressions.
4. Split forms with each side containing a different thickness or number of sheets are not recommended.

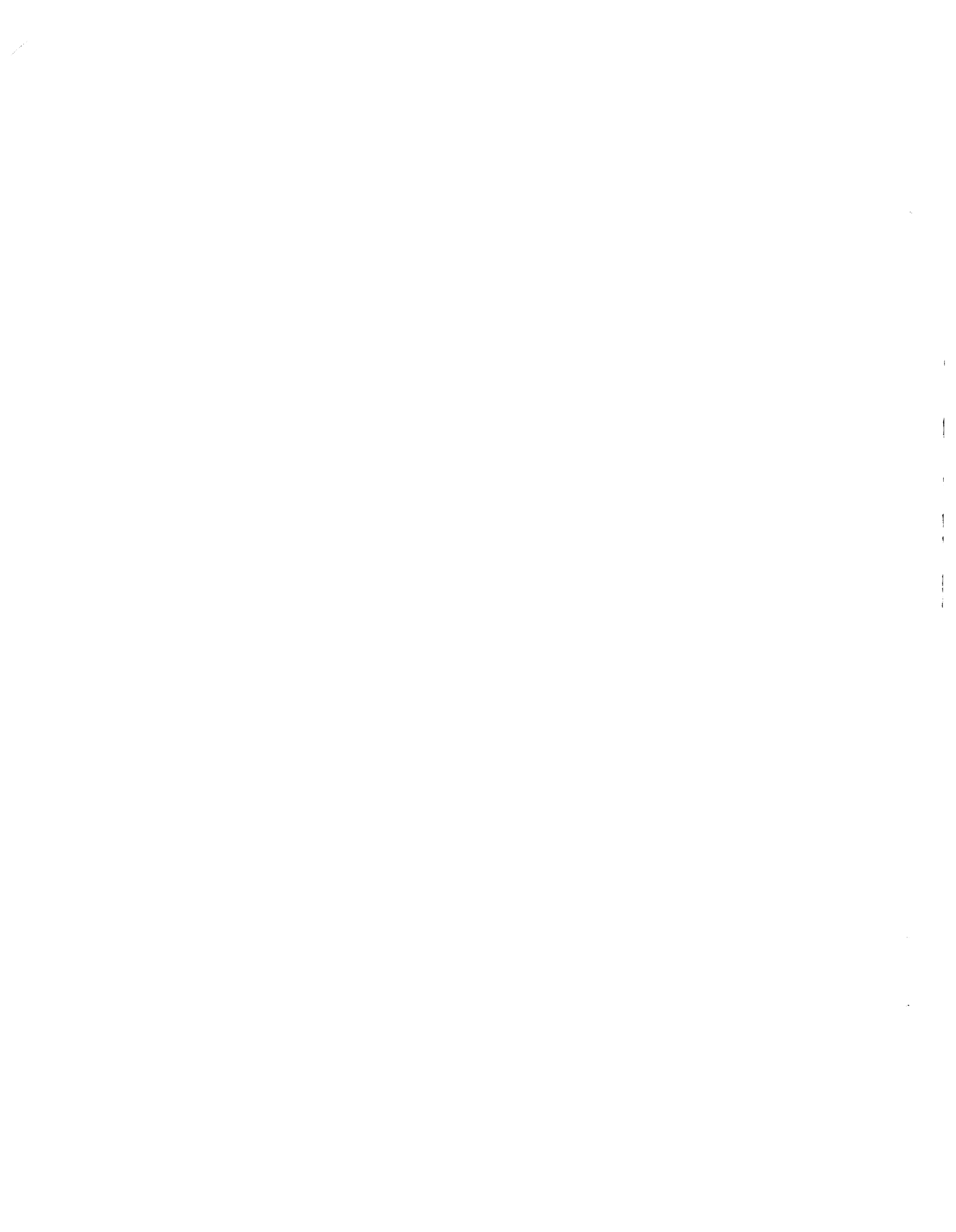

## **CHAPTER 3**

### **PROGRAMMER'S INFORMATION**

#### **3.1 GENERAL**

The LA120 uses escape sequences standardized by ANSI (American National Standards Institute) to control many of its features. For LA120 features lacking an ANSI standard escape sequence, additional escape sequences are defined within the extensions permitted by the ANSI system.

ANSI has established a flexible and comprehensive system for transmitting format and editing information. It can be used with printing terminals like the LA120 and with video terminals and printers and has the following important advantages.

1. It is well-defined and well-documented. This greatly decreases the chance of incompatible implementation and aids in achieving device independence in output.
2. It has ample provision for future extension without sacrificing compatibility with older programs. The syntax used in ANSI controls allows a large number of new controls to be added easily.
3. It is compatible with all frequently used communication protocols. In contrast, many other systems use control codes that are reserved for communication functions. In these other systems, codes used for line turnaround, disconnect, and synchronization get confused with those used to send parameter values.

Using the escape sequences described in this chapter, the programmer can control the following LA120 features.

- Printer character set
- Active position
- Linefeed-newline mode
- Horizontal pitch
- Horizontal margins
- Horizontal tabs
- Vertical pitch
- Form length
- Vertical margins
- Vertical tabs
- Product identification
- Alternate keypad mode

## 3.2 ESCAPE SEQUENCES

### 3.2.1 Parser Program

An escape sequence is a real-time call to a firmware program that changes an operating parameter of the LA120 printer. The purpose of the escape sequence is to enable control of the terminal's operating parameters from a remote computer or terminal. The remote machine sends a string of characters to the LA120. Upon being parsed (dissected and interpreted), the character string points to a particular firmware routine stored in the microprocessor memory. This routine implements the changes to the printer's operating parameters. Most of the escape sequences deal with forms control (e.g., right and left margins; top and bottom margins). Other sequences select the character set to be used for printing or linefeed-newline mode.

The escape sequence is processed by a master software program called the parser. At each level of the parser program there are choices selected from a look-up table and instructions as to what to do next. To parse the escape sequence ESC[4e (advance active line by 4), the computer program points to a table in which the character [ is found. The entry for [ has the choice of pointing to any of seven tables or of looping in the present table. The logic in the table entries for the [ character knows the next character is a number; therefore, it points to a table that contains numbers. The entry for [ also gives an instruction to parse the next character and perform the search in the number table. Finally, after searching through the tables for the characters [, 4, and e, the pointer points to a terminating routine that instructs the terminal to advance the active line by four lines and reinitialize the parser program.

### 3.2.2 Sequence Descriptions

The LA120 interprets escape sequences sent to it. None of the characters in an escape sequence are printed. When the end of the sequence is found (or an error occurs), the LA120 reverts to its normal printing mode. Control characters (characters with octal codes 000 through 037) may be embedded anywhere in an escape sequence. The control characters perform their normal function and have no effect on the escape sequence. If an escape sequence is received by the LA120 that it does not support, it is ignored.

An escape sequence that has been only partially processed when the operator enters SET-UP mode will complete when the operator leaves SET-UP mode. Escape sequences may also be entered and processed while in local mode and may be used in lieu of SET-UP commands.

In the lists of escape sequences that follow, the escape character (octal code 033) is designated as ESC. Numeric parameters are shown explicitly or designated as n, n<sub>1</sub>, n<sub>2</sub>, etc. The graphic characters in escape sequences are shown using the United States ASCII character set. The characters are spaced apart for clarity only, the space character (octal code 040) never appears in an escape sequence. The case of the characters in escape sequences is significant and must be exactly as documented.

A numeric parameter is a sequence of ASCII decimal digits. That is, octal codes 060 through 071. The parameter is interpreted as an unsigned decimal integer, with the most significant digit transmitted first. Leading zeros are allowed but are not necessary. A missing parameter is interpreted as a value of zero. Plus and minus signs are not allowed in parameters.

#### NOTE

**The space character (octal code 040) never appears in an escape sequence.**

Table 3-1 summarizes LA120 escape sequences. Paragraphs 3.2.2.1 through 3.2.2.12 describe these sequences in more detail.

**Table 3-1 LA120 Escape Sequences**

LA120 Feature	Escape Sequence*	Function/Comments*
Printer Character Sets	ESC ( A	Select character set of Great Britain.
	ESC ( B	Select character set of United States.
	ESC ( C	Select character set of Finland.
	ESC ( E	Select character set of Norway/Denmark.
	ESC ( H	Select character set of Sweden.
	ESC ( K	Select character set of Germany.
	ESC ( R	Select character set of France.
Active Position	ESC [ n '	Set active column to column n (character after n is octal code 140)
	ESC [ n a	Advance advance column by n columns.
	ESC E	Set active column to left margin and increment active line.
	ESC D	Increment active line (active column unchanged).
	ESC [ n d	Set active line to line n.
	ESC [ n e	Advance active line by n lines.
Linefeed-Newline Mode	ESC [ 20 h	Enable linefeed-newline mode.
	ESC [ 20 l	Disable linefeed-newline mode.
Horizontal Pitch	ESC [ w or ESC [ ow	Set horizontal pitch to 10 char/in.
	ESC [ 1 w	Set horizontal pitch to 10 char/in.
	ESC [ 2 w	Set horizontal pitch to 12 char/in.
	ESC [ 3 w	Set horizontal pitch to 13.2 char/in.
	ESC [ 4 w	Set horizontal pitch to 16.5 char/in.
	ESC [ 5 w	Set horizontal pitch to 5 char/in.
	ESC [ 6 w	Set horizontal pitch to 6 char/in.
	ESC [ 7 w	Set horizontal pitch to 6.6 char/in.
	ESC [ 8 w	Set horizontal pitch to 8.25 char/in.

**Table 3-1 LA120 Escape Sequences (Cont)**

LA120 Feature	Escape Sequence*	Function/Comments*
Horizontal Margins	ESC [ ns or ESC [n; os	Set left margin to column n.
	ESC [; ns or ESC [o; ns	Set right margin to column n.
	ESC [ n <sub>1</sub> ;n <sub>2</sub> s	Set left margin to column n <sub>1</sub> and set right margin to column n <sub>2</sub> .
Horizontal Tabs	ESC H	Set horizontal tab stop at active column.
	ESC I	Set horizontal tab stop at active column.†
	ESC [ g or ESC o g	Clear horizontal tab stop at active column.
	ESC [ 2 g	Clear all horizontal tab stops.
	ESC [ 3 g	Clear all horizontal tab stops.
	ESC 2	Clear all horizontal tab stops.†
	ESC [ n u	Set horizontal tab stop at column n.
	ESC [ n <sub>1</sub> ;n <sub>2</sub> u  ESC [ n <sub>1</sub> ;n <sub>2</sub> ; ...n <sub>x</sub> u	Set horizontal tab stops at column n <sub>1</sub> and at column n <sub>2</sub> .  Set horizontal tab stops at columns n <sub>1</sub> , n <sub>2</sub> , ... n <sub>x</sub> (x ≤ 16).
Vertical Pitch	ESC [ z or ESC [ o z	Set vertical pitch to 6 lines/in.
	ESC [ 1 z	Set vertical pitch to 6 lines/in.
	ESC [ 2 z	Set vertical pitch to 8 lines/in.
	ESC [ 3 z	Set vertical pitch to 12 lines/in.
	ESC [ 4 z	Set vertical pitch to 2 lines/in.
	ESC [ 5 z	Set vertical pitch to 3 lines/in.
	ESC [ 6 z	Set vertical pitch to 4 lines/in.



**Table 3-1 LA120 Escape Sequences (Cont)**

LA120 Feature	Escape Sequence*	Function/Comments*
Form Length	ESC [ n t	Set form length to n lines. Set top margin to line 1. Set bottom margin to line n. Set active line to line 1.
Vertical Margins	ESC [ n r ESC [ ; n r ESC [ n <sub>1</sub> ;n <sub>2</sub> r	Set top margin to line n. Set bottom margin to line n. Set top margin to line n <sub>1</sub> and set bottom margin to line n <sub>2</sub> .
Vertical Tabs	ESC J ESC 3 ESC [ l g ESC [ 4 g ESC 4 ESC [ n v ESC [ n <sub>1</sub> ;n <sub>2</sub> v ESC [ n <sub>1</sub> ;n <sub>2</sub> ; ... n <sub>x</sub> v	Set vertical tab stop at active line. Set vertical tab stop at active line.† Clear vertical tab stop at active line. Clear all vertical tab stops. Clear all vertical tab stops.† Set vertical tab stop at line n. Set vertical tab stops at line n <sub>1</sub> and at line n <sub>2</sub> . Set vertical tab stops at lines n <sub>1</sub> , n <sub>2</sub> , ... n <sub>x</sub> (x ≤ 16).
Product Identification	ESC [ C or ESC [ o c	LA120 transmits ESC [ ? 2 c
Alternate Keypad Mode	ESC = ESC >	Enable alternate keypad mode. Disable alternate keypad mode.

\* n represents a numeric parameter.

† This escape sequence is available for compatibility with the LA36.

### 3.2.2.1 Printer Character Sets

**United States and British Character Sets** – The LA120 is capable of receiving and printing both the United States ASCII character set and the British version in which the character “#” is replaced by the character “£”. The United States ASCII character set is shown in Table 3-2. Refer to Table 3-1 for the escape sequences that select the printer character sets of the United States and Great Britain.

**Table 3-2 United States ASCII Character Set**

Code	Char	Code	Char	Code	Char
040	space	100	@	140	'
041	!	101	A	141	a
042	”	102	B	142	b
043	#	103	C	142	c
044	\$	104	D	144	d
045	%	105	E	145	e
046	&	106	F	146	f
047	'	107	G	147	g
050	(	110	H	150	h
051	)	111	I	151	i
052	*	112	J	152	j
053	+	113	K	153	k
054	,	114	L	154	l
055	-	115	M	155	m
056	.	116	N	156	n
057	/	117	O	157	o
060	0	120	P	160	p
061	1	121	Q	161	q
062	2	122	R	162	r
063	3	123	S	163	s
064	4	124	T	164	t
065	5	125	U	165	u
066	6	126	V	166	v
067	7	127	W	167	w
070	8	130	X	170	x
071	9	131	Y	171	y
072	:	132	Z	172	z
073	;	133	[	173	{
074	<	134	\	174	
075	=	135	]	175	}
076	>	136	^	176	~
077	?	137	-		

**Optional Character Sets** – Five additional national character sets and an APL character set are available as an option. The national character sets are selected by the operator, using SET-UP commands, or by the programmer using escape sequences. The national character sets differ from United States ASCII in only a limited number of code positions.

The code differences among the national character sets are shown in Table 3-3. Refer to Table 3-1 for the escape sequences that select the optional printer character sets.

**3.2.2.2 Active Position** – Active position may be either active column or active line. Active column is defined as the column where the next character will normally be printed. Active line is defined as the line where the next character will normally be printed. Column and line numbers begin with one, not zero. Printable characters normally increment active column. Line feeds normally increment active line. Active column and active line are collectively known as active position.

**Table 3-3 Code Differences Among National Character Sets**

Character Set	Code										
	043	100	133	134	135	136	140	173	174	175	176
United States	#	@	[	\	]	^	`	{		}	~
Great Britain	£	@	[	\	]	^	`	{		}	~
Finland	#	@	Å	Ö	Ä	Ü	é	ä	ö	ä	ü
Sweden	#	É	Å	Ö	Ä	Ü	é	ä	ö	ä	ü
Norway/Denmark	#	À	Æ	Ø	Å	Ü	ä	æ	ø	ä	ü
Germany	#	§	Å	Ö	Ü	^	`	ä	ö	ü	ß
France	£	è	°	ç	§	^	`	é	ù	è	..

Active position is only loosely linked to the physical position of the LA120 print head and paper mechanism. In general, active column is only recorded when a character is actually printed. Any previous history of active column values is not significant. Active line is different because it may only be advanced, since backward paper motion is not allowed. When the LA120 is idle, active and physical positions are identical.

In the LA120, bell characters have only an active line attribute. They are not guaranteed to be sounded at any particular column within a line.

In addition to the normal position control characters (space, backspace, carriage return, line feed, horizontal tab, vertical tab, and form feed), active position escape sequences listed in Table 3-1 also modify active position.

**3.2.2.3 Linefeed-Newline Mode** – Linefeed-newline mode is controllable both by the operator and the programmer. If linefeed-newline mode is enabled, the characters line feed, vertical tab, and form feed each return the active column to the left margin in addition to their normal functions. Linefeed-newline mode may be enabled by the operator selecting choice 2 (line feed) in the printer new line character SET-UP command. The mode is disabled any time the operator selects choice 1 (none) or choice 3 (carriage return) in the printer new line character SET-UP command.

Table 3-1 contains the escape sequences that control linefeed-newline mode.

**3.2.2.4 Horizontal Pitch** – Horizontal pitch determines the width of printed characters as well as their spacing. The LA120 has eight different horizontal pitches. Any combination of pitches may be used on a single print line. Changing horizontal pitch modifies the active column. The resulting new active column is that of the first column boundary at or to the right of the physical position of the previous active column in the old pitch. It is calculated as:

$$\text{Newcol} = \frac{1 + (\text{Oldcol}-1) \cdot \text{Oldpitch}}{1 \text{ Newpitch}}$$

where: Newcol = new active column  
 Newpitch = new pitch in chars/in  
 Oldcol = old active column  
 Oldpitch = old pitch in chars/in

The division performed above is integer division. Any remainder or fractional part of the quotient is discarded.

The escape sequences that set horizontal pitch are listed in Table 3-1.

**3.2.2.5 Horizontal Margins** – Printing is permitted only within the inclusive left and right margins. A carriage return character sets the active column to the left margin. Attempting to move the active column left of the left margin sets the active column equal to the left margin. Attempting to move the active column more than one column right of the right margin executes an auto newline if auto newline is enabled. If auto newline is disabled, an error bell sounds and the character or command that attempted the motion is discarded.

Horizontal margins may be set so long as the following is true.

$$1 \leq \text{left margin} \leq \text{right margin} \leq \text{max column}$$

Note that maximum column is a function of horizontal pitch.

$$\text{maximum column} = 13.2 \text{ inches} * \text{horizontal pitch}$$

where the product is rounded down to the nearest column.

The horizontal margin escape sequences listed in Table 3-1 set the left and right horizontal margins.

**3.2.2.6 Horizontal Tabs** – The LA120 has 217 possible horizontal tab stops, one for each column. Tab stops are associated with column numbers, not physical positions on the paper. Thus, changing horizontal pitch will also change the physical position of tab stops. Each stop may be set or cleared independently. Setting a stop already set has no effect; the same is true for clearing a stop already cleared. Tab stops may be set or cleared without regard to margins or horizontal pitch.

The horizontal tab escape sequences used to set and clear horizontal tab stops are listed in Table 3-1.

**3.2.2.7 Vertical Pitch** – Vertical pitch determines the spacing between lines, not the height of printed characters. Changing vertical pitch does not affect active line number; but it does clear vertical margins. The escape sequences that set vertical pitch are listed in Table 3-1.

**3.2.2.8 Form Length** – Form length is defined in lines, not physical units. Therefore, changing vertical pitch will alter the physical form length. Forms may be from 1 to 168 lines in length. Changing form length clears vertical margins and defines the current line as line one. The escape sequence that sets form length is listed in Table 3-1.

**3.2.2.9 Vertical Margins** – Printing is permitted only on lines within the inclusive top and bottom margins. When vertical pitch or form length are changed, these margins are cleared; that is, the top margin is set to line one and the bottom margin is set to the form length. The following must be true to successfully set new vertical margins.

$$1 \leq \text{top margin} \leq \text{bottom margin} \leq \text{form length}$$

Whenever active line < top margin or active line > bottom margin, the active line is set to the top margin. For example, a line feed performed at the bottom margin will execute a form feed.

The escape sequences that set the top and bottom margins are listed in Table 3-1.

**3.2.2.10 Vertical Tabs** – The LA120 has 168 vertical tab stops set and cleared similar to horizontal tab stops. Vertical tab stops are associated with specific line numbers, not physical positions on the paper. Thus, changing vertical pitch changes the printing position of vertical tabs.

The escape sequences that set or clear vertical tab stops are listed in Table 3-1.

**3.2.2.11 Product Identification** – The LA120 terminal automatically transmits an answer to the ANSI standard request for a device attributes escape sequence.

The escape sequence that causes the LA120 to transmit its product identification escape sequence is listed in Table 3-1.

**3.2.2.12 Alternate Keypad Mode** – Alternate keypad mode allows application programs to differentiate between keystrokes performed on the optional numeric pad and those performed on the main keyboard so that the numeric pad may be used for commands or special functions.

Alternate keypad mode is controllable by the operator using the alternate keypad mode SET-UP command, or by the programmer. If alternate keypad mode is disabled, the keys on the optional numeric keypad transmit the codes that correspond to the keycap legends. If alternate keypad mode is enabled, each of these keys transmits the escape sequence specified in Table 3-4.

**Table 3-4 Escape Sequences Transmitted in Alternate Keypad Mode**

Key	Code Transmitted	
	Normally	Alternate Keypad Mode
PF1	ESC O P	ESC O P
PF2	ESC O Q	ESC O Q
PF3	ESC O R	ESC O R
PF4	ESC O S	ESC O S
ENTER	Same as RETURN key	ESC O M
,	,	ESC O l
-	-	ESC O m
.	.	ESC O n
0 (number)	0 (number)	ESC O p
1	1	ESC O q
2	2	ESC O r
3	3	ESC O s
4	4	ESC O t
5	5	ESC O u
6	6	ESC O v
7	7	ESC O w
8	8	ESC O x
9	9	ESC O y

The escape sequences that control alternate keypad mode are listed in Table 3-1.

### 3.3 CONTROL CHARACTERS

The LA120 receives the control characters listed in Table 3-5 and responds accordingly.

**Table 3-5 LA120 Control Characters**

Code	Mnemonic	Name
000	NUL	Null
003	ETX	End of Text
004	EOT	End of Transmission
005	ENQ	Enquiry
007	BEL	Bell
010	BS	Backspace
011	HT	Horizontal Tabulation
012	LF	Line Feed
013	VT	Vertical Tabulation
014	FF	Form Feed
015	CR	Carriage Return
016	SO	Shift Out
017	SI	Shift In
020	DLE	Data Link Escape
030	CAN	Cancel
032	SUB	Substitute
033	ESC	Escape
177	DEL	Delete

Control characters not listed in Table 3-5 are always ignored when received by the LA120. Paragraphs 3.3.1 through 3.3.17 describe each character.

#### 3.3.1 Null or Delete (NUL or DEL)

Null and delete characters cause no operation. But they are different from ignored characters in that they are disposed of without occupying space in the input buffer. Thus, they are fill characters and truly equivalent to idle marking time.

#### 3.3.2 End of Text (ETX)

If the LA120 is operating in half duplex with ETX turnaround, the end of text character is recognized as the turnaround character. If the LA120 is operating in any other full- or half- duplex mode, the ETX character has no effect.

#### 3.3.3 End of Transmission (EOT)

If the LA120 is operating in half duplex with EOT turnaround, the end of transmission character is recognized as the turnaround character. If the LA120 is operating in any other full- or half- duplex mode, the EOT character is recognized as a disconnect request, unless the auto disconnect feature is turned off. For disconnect request in half duplex with EOT turnaround, see Data Link Escape (DLE) (Paragraph 3.3.14).

#### 3.3.4 Enquiry (ENQ)

The LA120 automatically transmits its answerback message upon receipt of ENQ.

### **3.3.5 Bell (BEL)**

The bell character sounds a momentary 2400 Hz tone. No more than eight bells can be pending at any one time.

### **3.3.6 Backspace (BS)**

The backspace character decrements the active column, unless the active column is at the left margin, in which case the backspace character is ignored.

### **3.3.7 Horizontal Tab (HT)**

The horizontal tab character advances the active column to the next horizontal tab stop greater than the current active column, but no greater than the right margin. If there is no such tab stop, the active column is advanced to the column after the right margin.

### **3.3.8 Line Feed (LF)**

The line feed character increments the active line, unless the active line is at the bottom margin, in which case it sets the active line to the top margin of the next page. If linefeed-newline mode is enabled, the active column is set to the left margin.

### **3.3.9 Vertical Tab (VT)**

The vertical tab character advances the active line to the next vertical tab stop greater than the current active line but no greater than the bottom margin. If there is no such tab stop, the active line is set to the top margin (on the next page). If linefeed-newline mode is enabled, the active column is set to the left margin.

### **3.3.10 Form Feed (FF)**

The form feed character advances the active line to the top margin of the next page which may or may not be the physical top of the form. If linefeed-newline mode is enabled, the active column is set to the left margin.

### **3.3.11 Carriage Return (CR)**

The carriage return character returns the active column to the left margin. If carriage return is selected as the printer new line character, the active line is incremented.

### **3.3.12 Shift In (SI)**

The shift in character shifts the printer to the primary character set. If no secondary character set (such as APL) is installed, this character has no effect.

### **3.3.13 Shift Out (SO)**

The shift out character shifts the printer to the secondary character set. If no secondary character set (such as APL) is installed, or if alternate character set is disabled, this character has no effect.

### **3.3.14 Data Link Escape (DLE)**

If the LA120 is operating in half duplex with EOT turnaround, the data link escape character, when received or transmitted immediately prior to an EOT, causes the EOT to be interpreted as a disconnect request. If the LA120 is operating in any other full- or half-duplex mode, the DLE character has no effect.

### **3.3.15 Cancel (CAN)**

The cancel character terminates any pending escape sequence and causes the sequence to be ignored.

### **3.3.16 Substitute (SUB)**

The substitute character is interpreted as being in place of a character received in error. Characters received with parity errors are converted to the SUB character. If characters are ever lost due to input

buffer overflow, a SUB character is placed in the input buffer at that point. The SUB character is printed as the following graphic symbol:



The SUB character also has the effect of a cancel character.

### 3.3.17 Escape (ESC)

The escape character is interpreted as introducing an escape sequence. Escape sequences are described in detail in Paragraph 3.2.

## 3.4 APL CHARACTER SET

If the alternate character set SET-UP feature is enabled, the optional APL character set can be selected by the SO control character, independent of the national character set in use. The SI control character returns the printer to the previously selected national character set.

For the APL keyboard to work properly, the keyboard character set must have been set by the operator to United States or Great Britain. The APL character set is shown in Table 3-6.

**Table 3-6 APL Character Set**

Code	Char	Code	Char	Code	Char
040	space	100	--	140	
041	"	101	α	141	A
042	)	102	⊥	142	B
043	<	103	n	143	C
044	≤	104	L	144	D
045	=	105	ε	145	E
046	>	106	-	146	F
047	]	107	∇	147	G
050	√	110	Δ	150	H
051	^	111	ι	151	I
052	≠	112	∘	152	J
053	÷	113	'	153	K
054	,	114	□	154	L
055	+	115		155	M
056	.	116	τ	156	N
057	/	117	⊙	157	O
060	0	120	*	160	P
061	1	121	?	161	Q
062	2	122	ƒ	162	R
063	3	123	Γ	163	S
064	4	124	~	164	T
065	5	125	↓	165	U
066	6	126	u	166	V
067	7	127	ω	167	W
070	8	130	⋮	170	X
071	9	131	↑	171	Y
072	(	132	c	172	Z
073	[	133	←	173	{
074	;	134	↳	174	→
075	X	135	→	175	}
076	:	136	⊥	176	\$
077	\	137	+		



### 3.5 SAMPLE FORM SETUP USING ESCAPE SEQUENCES

All form control features available to the operator in SET-UP mode can also be transmitted to the LA120 using escape sequences. The sample form illustrated in Figure 3-1 could be set up using the escape sequences in Table 3-7.

**Table 3-7 Escape Sequences for Sample Form**

Escape Sequence	Function/Comments
ESC [ 1 z	Selects 6 lines/in.
ESC [ 6 6 t	Sets form length to 66 lines and sets top-of-form at current line.
ESC [ 4; 5 8 r	Sets top margin at line 4 and bottom margin at line 58.
ESC [ 4 g	Clears all vertical tabs.
ESC [ 8; 2 0; 2 5; 4 5 v	Sets vertical tabs at lines 8, 20, 25, and 45.
ESC [ 1 w	Sets horizontal pitch to 10 char/in.
ESC [ 3; 8 2 s	Sets left margin to column 3 and right margin to column 82.
ESC [ 2 g	Clears all horizontal tabs.
ESC [ 1 0; 2 1; 4 1 u	Sets horizontal tabs at columns 10, 21, and 41.

### 3.6 SYNCHRONIZATION

When the LA120 receives a character (other than the fill characters, NUL and DEL), it stores it in its 1000 character input buffer. When the printer is ready, characters are fetched from the input buffer and printed. If the printer falls behind by more than about 1000 characters, the input buffer overflows and data is lost. There are three ways to avoid buffer overflows.

1. Send data only as fast as it can be printed. When receiving data at 1200 baud or less, the LA120 can keep up with normal character sequences. Very short lines and multiple form feeds cannot be printed this fast. Fill characters may be used to slow the effective data transmission speed in these cases. Fill time formulas are given in Paragraph 3.6.2.
2. Limit the length of your message to the LA120's input buffer size. If the buffer is empty at the beginning of your transmission, you can send a message of about 1000 characters without worrying about buffer overflow.
3. Use a terminal synchronization protocol, such as XON/XOFF or restraint mode. Using a synchronization protocol, the LA120 can tell the data source when to pause in sending data and when to resume. Synchronization allows maximum throughput and eliminates the need for fill character calculations and message size limits.

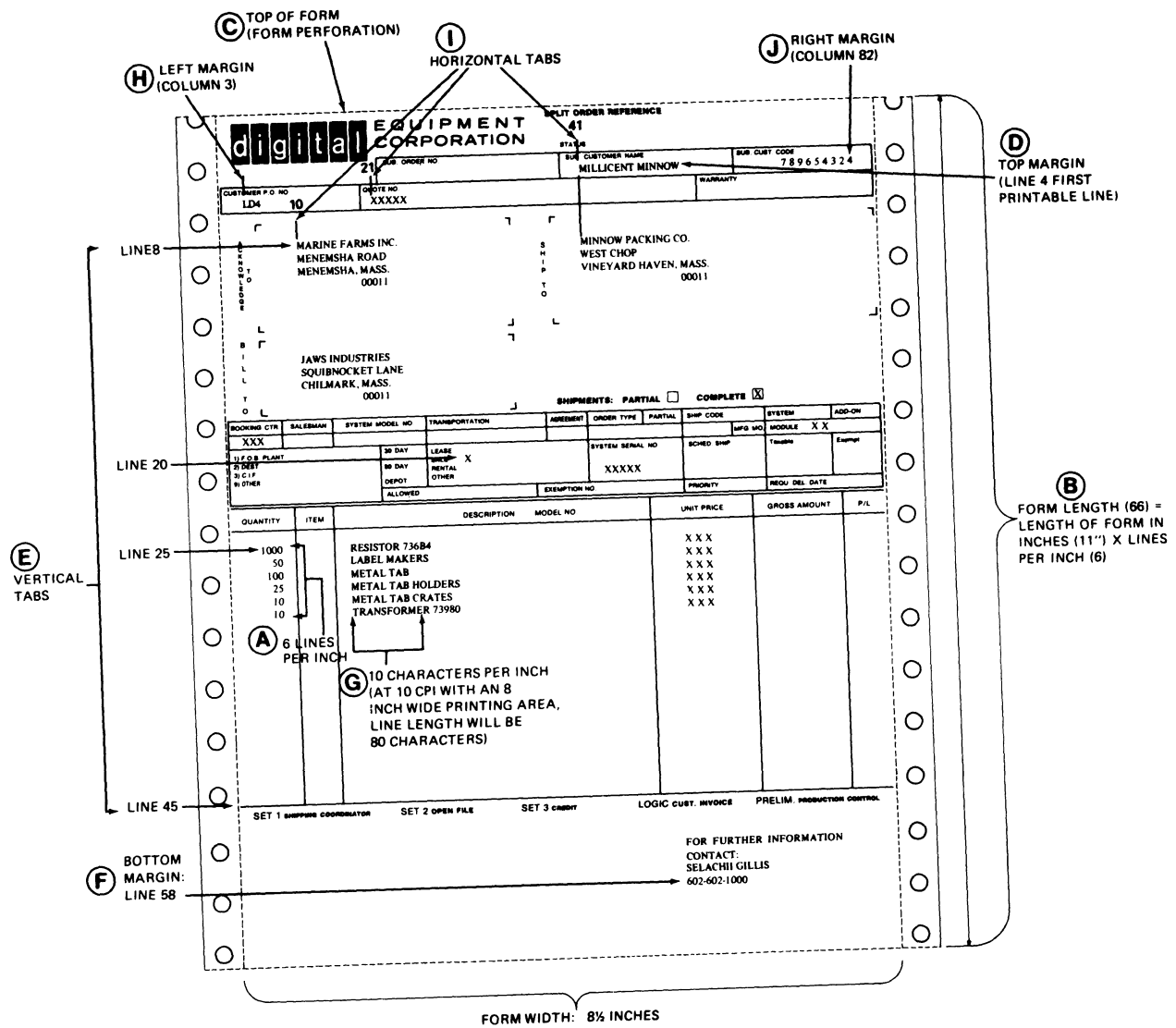

\* FORM LENGTH (66); LENGTH OF FORM IN INCHES (11) TIMES LINES PER INCH (6)

MA-2322

Figure 3-1 Sample Form SET-UP

When synchronization is used, the LA120 constantly monitors the number of characters stored in its input buffer. When the number of characters exceeds a "high water mark," the LA120 signals the data source to pause temporarily. Meanwhile, the printer continues to take characters out of the input buffer. When the number of characters remaining is less than a "low water mark," the LA120 signals that transmission may resume. The values used for the high and low water marks are selected by the buffer control SET-UP command.

The LA120 also sends a pause signal when the printer is not ready due to error conditions or operator actions. Running out of paper or detecting a print head jam can cause a pause request to be sent. The operator can induce a pause request by opening the cover or entering SET-UP mode.

The pause and resume signals to the data source are sent in either or both of two ways:

1. Using the control characters XON (octal code 021) and XOFF (octal code 023),
2. Using the EIA signal SRTS in restraint mode.

Restraint mode operation is suited for local, hard-wired installations, especially when the LA120 is used as a serial line printer replacement. Restraint mode is selected using SET-UP commands: "S" (secondary channel) must be "1" (enabled) and "M" (modern/protocol) must be "1" (full duplex, no EIA controls).

XON/XOFF is suitable for either local or remote operation so long as the connection is full duplex. To select XON/XOFF operation, the "X" set-up must be set to "1" (enabled). The XON/XOFF protocol is complicated by the fact that the synchronization characters may be interspersed between the characters typed at the LA120 keyboard. The operator can tell the data source to pause by typing XOFF (CTRL-S) and to resume by typing XON (CTRL-Q). To make sure that neither the buffer controller's nor the operator's pause requests are lost, typed characters may be transmitted with an XOFF character immediately following.

If XON/XOFF is enabled, the LA120 will transmit XON when first powered up and transmit enabled.

### 3.6.1 Synchronization Limits

Synchronization limits are given in Table 3-8.

**Table 3-8 Synchronization Limits**

<b>"B" SET-UP Choice</b>	<b>Low Limit</b>	<b>High Limit</b>
0 (small)	50 char	60 char
1 (large)	256 char	576 char

### 3.6.2 Fill Time Formulas

**3.6.2.1 Horizontal Movement** – Includes horizontal tabs and horizontal positioning escape sequences. First, convert to actual number of columns moved, then allow 15 ms for each of the first ten columns (30 ms in double-width pitches) and 5.5 ms for each additional column (11 ms in double-width pitches).

**3.6.2.2 Vertical Movement** – Includes line feeds, vertical tabs, form feeds, and vertical positioning escape sequences. First, convert to actual number of lines moved, then allow 33 ms for the first line moved up to 1/6 inch and 135 ms for each additional inch.

### 3.7 KEYBOARD OPERATION

The LA120 operator's console contains a typewriter-style keyboard resembling an office typewriter in key size, shape, and location. The keyboard also contains a 4-digit numeric display and eight binary indicators. There is provision for an optional, field installable numeric keypad.

The operator uses the keyboard to transmit codes. If the LA120 is transmit-enabled, codes are transmitted as each key is pressed except during auto repeat activity or with certain combinations of three or more keys held down which cannot occur in normal touch typing. If the LA120 is not transmit-enabled, keystrokes are stored in a 16-character buffer for future transmission. If more than 12 keystrokes are in the buffer, each keystroke generates a 400 Hz tone to indicate that the buffer is full or nearly full. The buffer will be cleared without transmission any time SET-UP mode is entered or exited, line/local status is toggled, or a break is transmitted.

#### 3.7.1 Auto Repeat

If auto repeat is enabled and a key that generates the space, backspace, or delete code or any printable character code is held down for more than 0.6 second, the code for that key is transmitted repeatedly at 7.5 char/sec per second, gradually increasing to 25 char/sec, or at a rate determined by the baud rate, whichever is slower. If auto repeat is in process, all keystrokes are ignored until the repeating key is released. If more than one key is held down prior to the start of auto repeat, only the last key pressed is subject to auto repeat.

#### 3.7.2 Printable Character Keys

There are 47 keys that generate printable character codes. The relationship between these keys and the SHIFT and CAPS LOCK keys is such that each of the 26 alphabetic keys transmits the lowercase code unless either or both of the SHIFT keys are down, or unless the CAPS LOCK key is down. Each nonalphabetic key generates two different codes. One code is generated if neither SHIFT key is down. The other code is generated if either or both of the SHIFT keys are down. Unlike the SHIFT LOCK key of a typewriter, the CAPS LOCK key does not affect the nonalphabetic keys. The codes generated by each code generating key are shown in Figure 3-2.

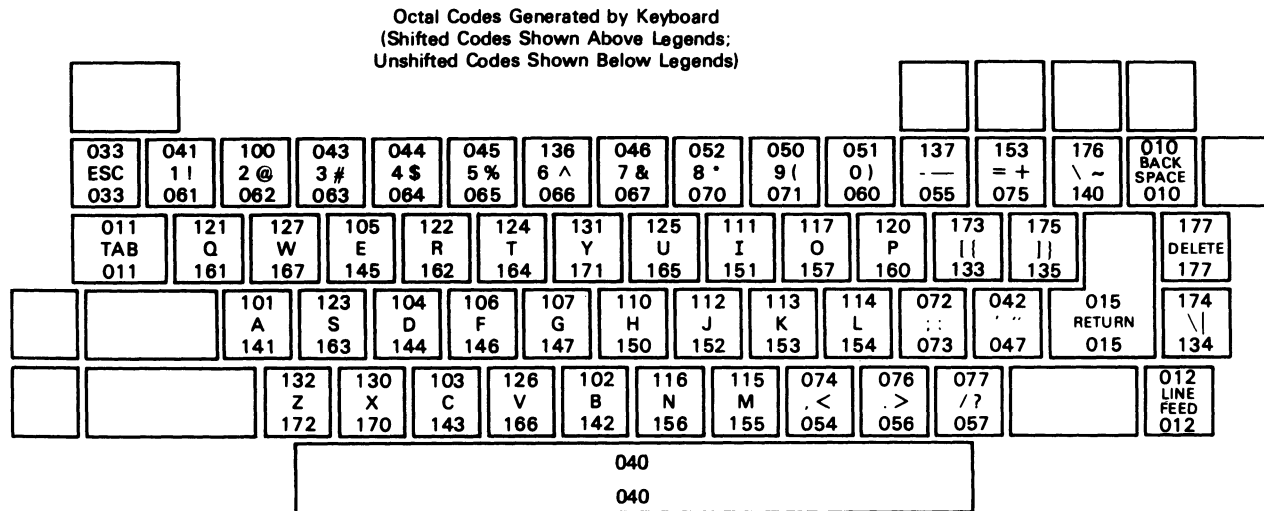

MA3386

Figure 3-2 Octal Codes Generated by Keyboard

### 3.7.3 Control Character Keys

There are seven keys that generate control character codes. The codes generated by these keys are independent of the SHIFT and CAPS LOCK keys. The control character keys and their functions are listed in Table 3-9.

In coded control half duplex, the RETURN key transmits the turnaround character automatically after transmitting its normal code or codes.

**Table 3-9 Control Character Keys**

Key	Octal Code	Function
RETURN	015 or 015 012	CR or NL
LINE FEED	012	LF or NL
BACK SPACE	010	BS
TAB	011	HT
Space Bar	040	SP
DELETE	177	DEL
ESC	033	ESC

### 3.7.4 CTRL (Control) Key

The CTRL key is used in conjunction with certain other keys on the keyboard to generate control character codes. The CTRL key is also used in conjunction with the SET-UP key to enter SET-UP mode.

The codes generated and keys affected by the CTRL key are independent of SHIFT and CAPS LOCK keys. It is never necessary to hold both the CTRL key and the SHIFT key down in combination with another key to generate control character codes. Also, there is only one CTRL key combination for each of the 32 control characters. Because of these requirements, there are three control characters whose locations on the LA120 may differ from other terminals. These characters and their locations on the LA120 and other terminals are shown in Table 3-10.

**Table 3-10 Variations in Control Character Locations**

Code	LA120	Other Terminals
NUL (000)	CTRL - <span style="border: 1px solid black; padding: 2px;">Space Bar</span>	CTRL-SHIFT - <span style="border: 1px solid black; padding: 2px;">@ 2</span>
RS (036)	CTRL - <span style="border: 1px solid black; padding: 2px;">~ \ /</span>	CTRL-SHIFT - <span style="border: 1px solid black; padding: 2px;">^ 6</span>
US (037)	CTRL - <span style="border: 1px solid black; padding: 2px;">? /</span>	CTRL-SHIFT - <span style="border: 1px solid black; padding: 2px;">- _</span>

The characters and codes generated by each key when the CTRL key is held down are shown in Figure 3-3.

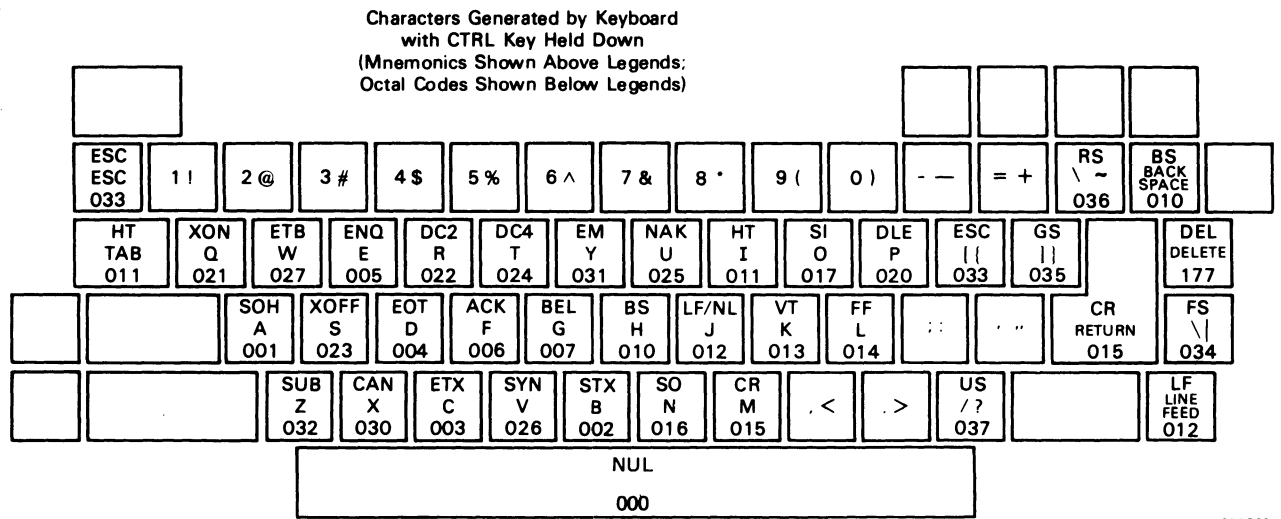

MA3387

Figure 3-3 Characters Generated by Keyboard with CTRL Key Held Down

### 3.7.5 Optional Auxiliary Keypad

The optional auxiliary keypad contains 18 keys that transmit the codes for the characters or escape sequences specified in the escape sequences section of this chapter (Paragraph 3.2).

### 3.7.6 BREAK Key

Pressing the BREAK key causes the LA120 to transmit a short break signal of 233 ms duration.

Holding one or both SHIFT keys down and pressing the BREAK key causes the LA120 to transmit a long break disconnect signal of 3.5 seconds duration.

The interface leads involved in transmitting break signals are described in Chapter 4 of the *LA120 User Guide*.

### 3.7.7 VIEW Key

If automatic view is in use and the printer has been idle but has not yet timed out the automatic view delay time, pressing the VIEW key causes the view operation to be performed.

If automatic view is not in use, pressing and holding the VIEW key causes the print head to idle at the viewing position. With the VIEW key released, the print head idles at the ready to print position.

Where there is no character to print, the carriage moves to the print cell immediately to the left of the cell designated by the active position (ready to print position). If the printer remains idle longer than the automatic view delay time, the carriage moves to the right to facilitate viewing of the last character printed (viewing position).

The automatic view delay time is a function of keyboard activity. If characters are being typed at a touch typing rate or faster, the time is set long enough to prevent erratic carriage motion. Otherwise, it is set to provide instant visibility of single typed or received characters. The automatic view operation may be disabled by the operator using a SET-UP command (SET-UP Z).

## **CHAPTER 4**

### **LA120 THEORY OF OPERATION**

#### **4.1 BASIC SYSTEM CONFIGURATION**

A block diagram of the LA120 is shown in Figure 4-1. The LA120 is a microprocessor-controlled system that utilizes the interaction of firmware programs with hardware circuits to perform control functions and provide functional characteristics.

As shown in Figure 4-1, the microprocessor, memory, and peripheral devices communicate via a common data bus. Peripheral devices in the LA120 include the following major functional items:

1. A single chip LSI printer controller that provides an interface to all functional elements of the printer,
2. A serially accessed non-volatile memory that stores set-up data when machine is turned off,
3. A keyboard consisting of an array of switches and a number of LED displays, and
4. A serial transmitter and receiver that provides data communication interface.

##### **4.1.1 Microprocessor**

The LA120 firmware is executed by an 8080A 8-bit microprocessor running from a 2 MHz clock. Although the microprocessor has a 16-bit address space, typically only part of the address is decoded by many devices on the bus. The microprocessor receives interrupt requests and RST vectors from the DC305 printer controller. When powering up, the microprocessor's reset line is asserted, thus starting program execution from location 0 with interrupts disabled.

##### **4.1.2 Device Addressing**

Both memory and I/O addressing are used in the LA120. In many cases, address lines are used to output data to devices as well as to select them. Conversely, data bits are used in some cases to select parts of a device.

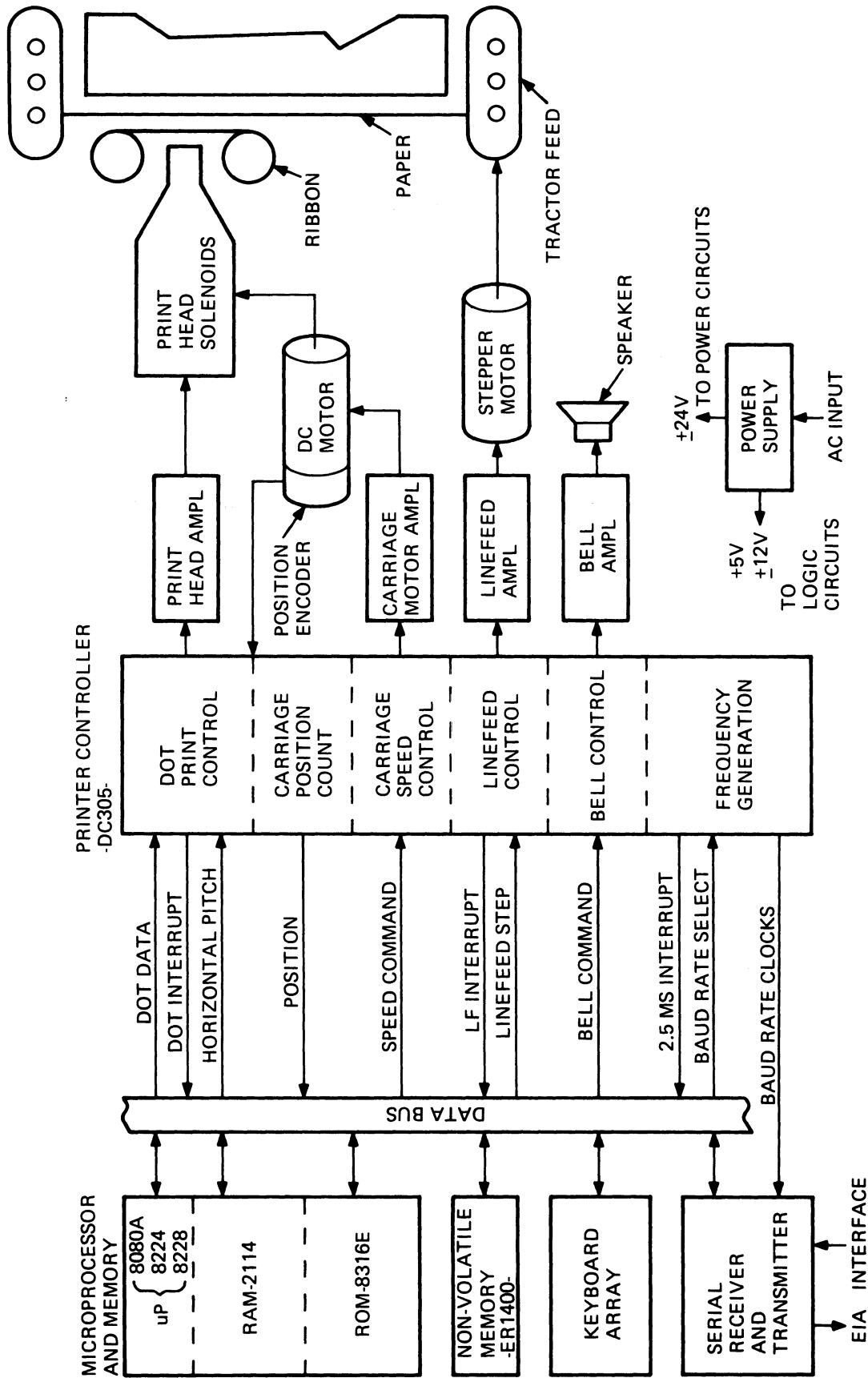

MA-4707

Figure 4-1 LA120 Block Diagram



**4.1.2.1 Memory Space** – LA120 memory read/write decoding is summarized in Table 4-1.

**Table 4-1 LA120 Memory Read/Write Decoding**

Address Range*	Device
0000H – 0FFFH	ROM
1000H – 1FFFH	ROM
2000H – 2FFFH	ROM
3000H – 3FFFH	Keyboard (read)/Display (write)
4000H – 4FFFH	RAM
5000H – 5FFFH	RAM
6000H – 6FFFH	Non-volatile memory
7000H – 7FFFH	DC305 printer controller
8000H – FFFH	Not used – reserved for options

\*The “H” suffix indicates hexadecimal notation.

**4.1.2.2 I/O Space** – LA120 I/O space is used as shown in Table 4-2.

**Table 4-2 I/O Space Allocation**

I/O Address (Binary)*	Device
0xxx xx0x	8251A USART
0xxx xx1x	Utility I/O Ports
1xxx xxxx	Not used – reserved for options

\*x = Don't care.

### 4.1.3 Interrupts

The LA120 receives interrupts from the DC305 printer controller and the 8251A USART. The DC305 will present one of four interrupt vectors to the microprocessor, depending on the source of the interrupt request(s). These are shown in Table 4-3.

**Table 4-3 Interrupt Vectors**

Interrupt Vector	Source of Interrupt Request		
	DC305 Dot/Timer	8251A USART RxRdy	DC305 2.5 ms Clock Tick
RST 3	F	F	T
RST 7	F	T	F
RST 3	F	T	T
RST 5	T	F	F
RST 1	T	F	T
RST 3	T	T	F
RST 1	T	T	T

As Table 4-3 indicates, the USART receiver ready interrupt is masked by either or both of the other interrupt sources.

#### 4.1.4 ROM

The standard LA120 has five 16K bit ROMs in sockets. They occupy addresses 0000H-07FFH, 0800H-0FFFH, ..., 2000H-27FFH, respectively. The European/APL options require additional ROM from 2800H-2FFFH. The ROM sockets actually decode only address bits A12-A15; A11 is a chip select on the 16K ROM chip. The conventional ROM placement is shown in Figure 4-2a.

The European/APL option ROM is a 64K bit device (of which only 32K is used) replacing ROM 4 in the rightmost socket. When 64K bit ROMs are phased in for the standard LA120, the socket now used for ROM 0 will be addressed by 000H-1FFFH and ROM placement will be as shown in Figure 4-2b.

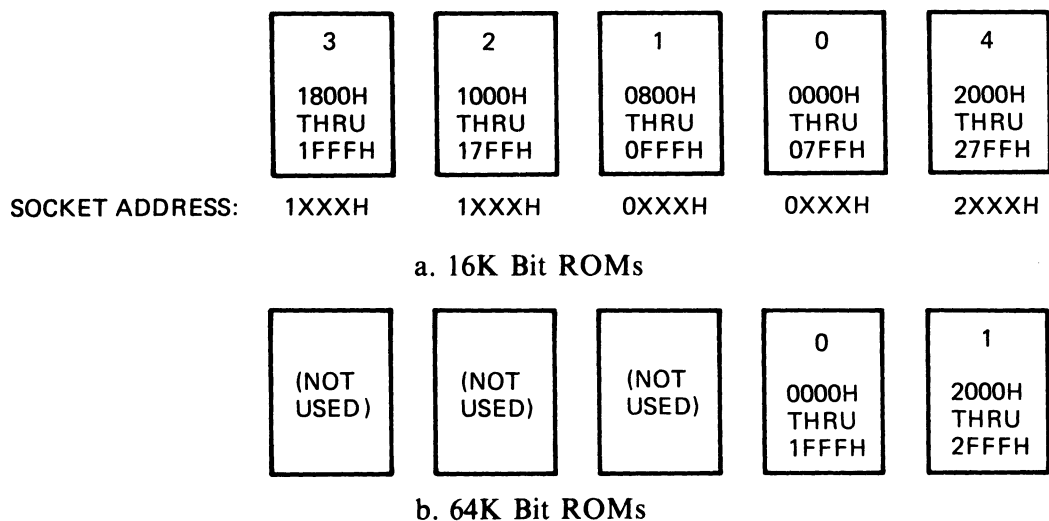

MA-4703

**Figure 4-2 ROM Placement**

#### 4.1.5 RAM

The standard LA120 has 2K bytes of RAM. This RAM is logically in two parts, one addressable from 4000H-4FFFH and the other from 5000H-5FFFH. RAM addresses are not fully decoded, so that each 1K portion of the RAM has “ghosts” at 1K intervals in its address range. To be exact, address bits A11 and A10 are not significant. Thus, locations 4000H, 4400H, 4800H, and 4C00H are identical. By convention, LA120 firmware defines RAM to be the contiguous 2K space from 4C00H-53FFH. At no time does the firmware rely on the ghosting effect, nor is it tested by RAM diagnostics. The RAM address map is shown in Figure 4-3.

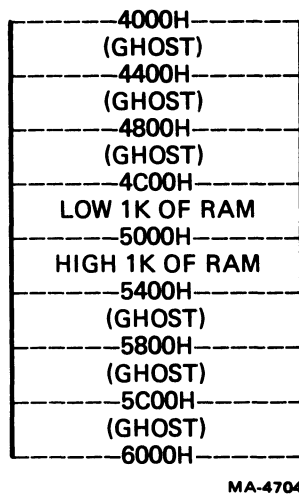

Figure 4-3 RAM Address Map

#### 4.1.6 Keyboard

In the LA120, the microprocessor directly reads the keyboard switch array, filters the data, and generates the proper codes or other actions in firmware, thereby giving the programmer complete freedom in specifying keyboard functionality.

**4.1.6.1 Keyboard Addressing (Table 4-4)** – The keyboard switch array is read using memory-mapped I/O. All reads in the address range 3000H-3FFFH will select the keyboard switch array.

Keyboard addresses are only partially decoded: in particular, address bits A5-A11 are ignored. The keyboard switch array appears to the microprocessor as 16 bytes of bit-encoded data – one bit per switch. Switches are grouped into two banks: the first bank is selected by A3, the second by A4. If both are selected, the microprocessor will read the logical OR of the two. By convention, LA120 firmware uses addresses 3008H-3017H to access the keyboard which relates, in hardware, to a direction of scan from BREAK toward ESCAPE. The direction was originally arbitrary but is now crucial to proper operation of the receive only control panel in the LA120-RA.

Bits that read as 0's are open, undepressed keys, while 1's are keys that are closed. In both banks, data bits D0-D4 contain the state of regularly decoded switches; bits D5 and D6 are constant 1's. In the first bank only, bit D7 contains data for separately decoded switches; in the second bank, D7 is always 0.

**Table 4-4 Keyboard Addressing**

Address	Data Bit							
	D7	D6	D5	D4	D3	D2	D1	D0*
3008	space bar	(unused)		BREAK	LOCAL LF	no key	PF4	N.
3009	cover	"	"	BS	DEL	 \ 	LOCAL FF	PF3
300A	paper	"	"	~ \ ~	opt LF	no key	HERE IS	PF2
300B	SHIFT	"	"	+ =	} ]	LINE LOCAL	LF	PF1
300C	CAPS LOCK	"	"	- _	{ [	" '	N, N-	N-
300D	CTRL	"	"	) 0	P	: ;	? /	N0
300E	RET	"	"	( 9	O	L	> .	N9
300F	SET-UP	"	"	* 8	I	K	< ,	N8
3010	(unused)	"	"	& 7	U	J	M	N7
3011	"	"	"	^ 6	Y	H	N	N6
3012	"	"	"	% 5	T	G	B	N5
3013	"	"	"	\$ 4	R	F	V	N4
3014	"	"	"	# 3	E	D	C	N3
3015	"	"	"	@ 2	W	S	X	N2
3016	"	"	"	! 1	Q	A	Z	N1
3017	"	"	"	ESC	TAB	VIEW	RO flag	ENTER

\* Nx = key labeled "X" on numeric pad.

**4.1.6.2 Switch Matrix** – All of the keys in data bits D0–D4 are part of a single two-dimensional switch matrix. As a result of the keyboard’s design, simultaneous pressing of three or more keys can make it appear that one or more additional keys are also pressed but in fact are not. These false key-down indications are detected by LA120 firmware, and prevented from generating any codes.

**4.1.6.3 Separately Decoded Keys** – Certain inputs from the keyboard must always be readable: these have been separately decoded and thus their data is always valid. These inputs are all in the first bank of switches, in data bit D7. The eight separately decoded keys are the space bar, cover interlock, paper out sensor, SHIFT key, CAPS LOCK key, CTRL key, RETURN key, and SET-UP key. The cover interlock will read 0 if open, 1 if closed; the paper out sensor is 0 if paper is out, 1 if paper is present.

**4.1.7 Display**

The LA120 has a 4-digit seven-segment LED display and eight individual LEDs above the keyboard array. Writes to addresses 3000H–3FFFH will access the display. Address bits A5–A11 are “don’t cares.” All data bits are “don’t cares.” In the LA120 firmware, address bits A8–A15 are always 00110000, while bits A5–A7 are not standardized.

**4.1.7.1 LEDs (Table 4-5)** – The eight LEDs are all randomly accessible and individually latched. The state of the latches on power up is not defined. Writes to binary addresses 0011xxxxxx0yyy0 will turn off LED yyy. Writes to binary addresses 0011xxxxxx0yyy1 will turn on LED yyy. In addition, every write to an LED latch resets the 4-bit BCD digit counter.

**Table 4-5 LA120 LEDs**

Item	Positions and Labels							
Label	ON LINE	LOCAL	ALT CHAR SET	(blank)	CTS	DSR	SET-UP	PAPER OUT
Position	#7	#6	#5	#4	#3	#2	#1	#0

**4.1.7.2 Seven Segment Display** – The four 7-segment digits are addressed sequentially through a 4-bit counter when a write is done to addresses 0011 xxxx xxx1 xxxx. The counter is reset by writing an LED latch (or it can overflow after 16 increments). Each write to a seven-segment digit increments the counter, as well as sending segment data and turning on the selected digit. The 16 states of the counter are shown in Table 4-6.

**Table 4-6 Seven Segment Display Countr**

Counter Value	Digit
0000	none – reset to this value by LED write
0001	ones
0010	tens
0011	hundreds
0100	thousands
0101	none
.	.
.	.
.	.
1111	none – next increment wraps around to 0000

Data is sent to the seven-segment digits in address bits A0–A3 in inverted BCD. For example, if A0–A3 are 1111, a zero will be displayed, if 1110, one, etc. The special value 0000 displays a blank. The digit currently selected will remain intensified until the counter is incremented or reset. In order to display a multidigit number, the firmware sends data sequentially to the four digits at a high enough rate to avoid perceived flicker.

**4.1.8 Non-Volatile Memory**

Memory references to binary addresses 0110xxxxxxxxxxx will access the ER-1400 non-volatile memory. Each such reference will have one wait state inserted. The ER-1400 is a serial memory, with a capacity of 100 14-bit words. The microprocessor talks to it through three general-purpose control lines, assigned to address bits A8–A10, a clock input on A0, and a data/address read/write line in data bit D7.

The ER-1400 only operates when the firmware supplies it with a clock in the frequency range of about 11–18 kHz. While bit-banging the clock, the firmware manipulates control lines and data line to perform the basic operations shown in Table 4-7.

**Table 4-7 Non-Volatile Memory Operations**

Control Lines	Operation
000	Standby
001	Read
010	Erase
011	Write
100	Not used
101	Shift data out
110	Accept address
111	Accept data

All data and address transfers to and from the ER1400 non-volatile memory are done in bit serial fashion using a single data pin. Timing for the clock signal is generated by the firmware program and depends on instruction execution times. To address a word in the non-volatile memory, the program presents two consecutive 10-bit addresses (total = 20 bits), which have been already decoded into two 1-of-10 codes, corresponding to the row (ten's address) followed by the column (unit's address).

**Example:** Address 60 - 0001000000 - 0000000001

The electromechanical portions of the LA120 are placed in a quiescent state with interrupts disabled prior to accessing the non-volatile memory. This allows the timing of the firmware-generated clock signal to be precise. Because interrupts are disabled, the non-volatile memory access routines continue to track the print head using a polling technique, thus preventing any possibility of losing track of print head position.

#### 4.1.9 DC305 Printer Controller

Memory references to addresses 0111 xxxx xxxx xxxx will select the DC305 printer controller. Address bits A2–A11 are ignored for both reads and writes; A0 and A1 are also ignored in reads. One wait state is generated for each access to the DC305. Write accesses must be at least 7  $\mu$ s apart; there is no restriction on reads. Most writes to the DC305 pass additional subaddressing data in the data field.

A full description of the DC305 is given in Paragraph 4.2.

#### 4.1.10 8251A USART

All I/O to ports 0xxxxx0x accesses the 8251A USART. The USART itself decodes address bit A0, so that if A0 = 0 a data port is accessed, while if A0 = 1 a control/status port is accessed. By convention, the LA120 firmware uses the lowest valued I/O port numbers. The USART ports are as shown in Table 4-8.

**Table 4-8 8251A USART Ports**

<b>Input/Output</b>	<b>Port</b>	<b>Function</b>
Input	0xxx xx00	Received Data Buffer
Output	0xxx xx00	Transmitted Data Buffer
Input	0xxx xx01	Status Flags
Output	0xxx xx01	Mode/Command Control

The 8251A requests an interrupt whenever RxRDY (receiver ready) is asserted. If no other interrupts are pending, this will result in a RST 7 interrupt. Reading the received data buffer resets RxRDY and thus the interrupt request.

LA120 firmware checks the USART transmitter status via TxE (transmitter empty), not TxRDY (transmitter ready). This avoids an extra character time latency in sending XON/XOFF commands.

### 4.1.11 Utility I/O Ports

I/O addresses 0xxx xx1x select utility I/O ports. These consist of one 6-bit input port and one 6-bit output port. The outputs are reset by the power-up sequence. Bit assignments of these ports are given in Table 4-9.

Table 4-9 Utility I/O Ports

Port	Data Bit	Function
Input	0	Clear To Send
	1	Ring Indicator
	2	Option Present Indicator: 0 = option present
	3	Loopback Gate Indicator
	4	(not used)
	5	(not used)
	6	Secondary Received Line Signal Detect
	7	Received Line Signal Detect
Output	0	Data Terminal Ready
	1	(not used)
	2	(not used)
	3	Loopback Enable
	4	(not used)
	5	(not used)
	6	Baud Rate Clock Division Factor (0 = 16, 1 = 64)
	7	External Reset Signal

The loopback enable disconnects the received and transmitted data serial lines from the external interface and connects them together. It is not currently tested or used by LA120 firmware.

## 4.2 DC305 PRINTER CONTROLLER

The DC305 printer controller performs functions that are beyond the capabilities of the microprocessor and provides an interface between the microprocessor and the printer electromechanical components.

### 4.2.1 Dot Print Control

When there is at least one character to print, the microprocessor loads print head dot pattern data into a buffer whose output selects head drivers to be activated. When carriage speed and position are appropriate for printing, the microprocessor enables printing and enables the dot interrupt.

Print head motion signals from the carriage position encoder are combined with horizontal pitch SET-UP data from the microprocessor to trigger a countdown timer that allows selected head drivers to be turned on. At the termination of the count, the drivers are turned off and the buffer advances. When there is room for more dot pattern data in the buffer, a dot interrupt is generated, requesting that the microprocessor load more dot data into the buffer. When there is no more data to be printed, the microprocessor disables the dot interrupt. When the buffer becomes empty, printing ceases.



#### **4.2.2 Carriage Position Count**

Print head motion signals consist of a pair of asynchronous logic levels whose states change in quadrature to each other (00, 01, 11, 10, 00) as the carriage moves. After synchronization, the state changes accumulate in an 8-bit binary up/down counter as carriage position. The microprocessor periodically reads the counter to track carriage position over the entire width of the carriage and to determine carriage speed.

#### **4.2.3 Carriage Speed Control**

The voltage supplied to the dc motor is controlled by a pair of pulse streams. The first pulse stream has a duty cycle that is proportional to the binary value of a microprocessor-supplied speed command. The second pulse stream has a duty cycle that is proportional to the frequency of print head motion signal state changes (i.e., motor speed). The integrated pulse streams are subtracted to yield the motor voltage. A steering circuit interchanges the roles of the two pulse streams to provide direction control as a function of the directions of the speed command and the motor speed.

#### **4.2.4 Line Feed Control**

The line feed stepper motor is controlled by a two bit state word that controls the polarity of the voltage to each of the motor windings and a third bit that controls the amplitude of the current in the windings. Higher current is used to run the motor rather than to hold a steady position.

The timing of state changes during line feeding is completely under control of the microprocessor, with the aid of a programmable timer interrupt that is made available by utilizing the countdown timer of the dot print control circuit in a timer mode rather than in a printing mode.

#### **4.2.5 Bell Control**

Latches and gating logic enable the microprocessor to control the propagation of either a 400 Hz signal or a 2400 Hz signal to a small loudspeaker that supplies the bell function and acts as an audible warning device. The microprocessor can also control the application of an ultrasonic chopping signal to the bell drive signal that has the effect of reducing the energy content in the audio range and thus acts as a volume control.

#### **4.2.6 Frequency Generation**

Many processes in the LA120 depend on timing signals for proper operation. The master timing source is the 18 MHz crystal that drives the 8224 clock. The 8224 clock provides a 2 MHz signal that is used by the 8080A microprocessor, the 8251A USART, and the DC305 printer controller as their primary timing inputs. The 2 MHz clock input to the printer controller is divided by 13, yielding approximately 153.6 kHz, which is the clock rate that is used to drive most of the sequential logic in the printer controller. A divider chain produces 76.8 kHz, 38.4 kHz, 19.2 kHz, 9.6 kHz, 4.8 kHz, 2.4 kHz, and 1.2 kHz signals. A divide-by-3 circuit produces 400 Hz. The signals from 153.6 kHz to 1.2 kHz drive a bit rate multiplier in the carriage speed control circuit to produce the signal whose duty cycle is proportional to speed command. The 400 Hz signal provides an interrupt to the microprocessor every 2.5 ms, which allows firmware processes to run periodically and thus be capable of performing timing-dependent operations. A baud rate generator circuit further divides various outputs of the divider chain to produce baud rate clock signals for the lower baud rates and the split baud rates. A baud rate selector circuit allows the microprocessor to select various outputs of either the divider chain or the baud rate generator to be supplied as baud rate clock signals to the USART.

#### **4.2.7 Tick Alarm**

To prevent a microprocessor failure from causing physical harm to power circuits or electro-mechanical components, the DC305 has a special monitoring function that requires the microprocessor to prove its integrity by sending a clear tick command every 2.5 ms. Failure to do this is proof of malfunction and results in disabling most chip outputs. The DC305 powers up with tick alarm activated so that outputs are disabled until a programmed initialization sequence has been completed.

#### **4.2.8 Interrupt Vectors**

The DC305 can request interrupts at either vector RST 5 or vector RST 3. If both interrupts are requested, an interrupt to vector RST 1 results. The RST 3 interrupt is always due to the 2.5 ms (400 Hz) clock tick, while the RST 5 interrupt may be due to either the real-time clock timeout (typically while line feeding) or due to the dot FIFO being half empty (during printing).

### **4.3 LA120 FIRMWARE OVERVIEW**

#### **4.3.1 Scheduling**

Processes run at four priority levels: highest priority is interrupt level (with interrupts disabled), then tick level, interlaced tick level, and (lowest) background level. Note that except for interrupt service routines, interrupts are normally kept enabled. The hardware interrupt vector scheme subdivides interrupts into two priorities, with receiver ready interrupts below all others. Firmware then further divides the higher level so that dot or timer interrupts take priority over tick interrupts.

Processes that run at background are the least time-critical, since background may be locked out by higher priority processes for short periods of time. On the whole, though, background gets the lion's share of processor time, typically more than 50 percent. Tasks that run in background include line image formatting, print scheduling, SET-UP command interpreting, and the ANSI parser. All printing, slewing, and vertical motion is originally scheduled by background level routines, even though executed at higher priority. When the processor is idle, it will be looping at background level.

Interlaced tick level processes execute periodically after noninterlaced tick. Every interlaced tick process runs once every 1, 2, 4 or 8 ticks, where a tick is 2.5 ms. This is accomplished by a round-robin scheduler, where each of eight phases is executed, in turn, on successive ticks. Each phase runs to completion before the next phase is begun. Examples of interlaced tick processes are the keyboard handler, communications protocol handler, and display handler.

Noninterlaced tick processing is begun immediately after taking a tick interrupt; interlaced tick follows its completion. Currently, servo control comprises all of noninterlaced tick processing. This level of processing must be guaranteed to finish before the next tick interrupt comes along. Noninterlaced tick now takes about 700  $\mu$ s on average.

Interrupt service routines are the most time-critical and are kept as short and fast as possible. They include the dot FIFO interrupt, timer mode interrupt, and USART receiver ready interrupt.

Processes like initialization and non-volatile memory handling require that interrupts be off while running and thus effectively run at highest priority.

#### **4.3.2 ROM Layout**

Standard LA120 firmware occupies 10K bytes and thus normally lives in five 16K bit ROMs. The first four ROMs are treated as a group (in anticipation of 64K bit ROMs) and consist of code and tables judged low risk – that is, unlikely to change. The fifth ROM is reserved for high risk data. It is primarily tables but does have some executable code as well.

To get the European/APL options, a sixth ROM must be installed. The presence of this ROM is flagged by its first byte of zero. When optional features are invoked, routines in the standard set of ROMs test this byte to see if the options are enabled.

Each ROM has a one byte checksum. This requires that every byte in each ROM be fully defined. Thus, the fourth and fifth ROMs have large sections of padding (all 0FFH bytes) to fill up empty spaces. Many tables also have smaller sections of padding contiguous with them. Because of this padding and the checksums, any changes to the ROM patterns will usually require recalculating the padding section sizes and checksum values.

### **4.3.3 RAM Layout**

The LA120 has 2K bytes of RAM. The first 1K is used for the input buffer, a circular queue used to store characters received from the USART or that have been echoed locally. The next page (where a page is 256 bytes starting on a multiple of 256) contains several small buffers, the stack, and the tab bit maps. The page after that contains all non-volatile parameters and other variables. Thus, after an initial LXI H,FOOONE is performed, usually only a MVI L,LOW FOOTWO is needed to reference a second variable.

RAM locations are all written to zero at power-up time. If a location needs to be initialized to another value, its initial value is contained in a list processed by a RAM initialization routine.

## **4.4 PRINT CONTROL FIRMWARE**

One of the more complicated operations in the LA120 firmware is the starting of the print operation after a carriage return or tab. The DC305 chip will only begin the printing operation after it has been given a print start command. This command will be executed at the next point at which printing can legitimately be started. This section deals largely with the routines for ensuring that the print start occurs under the proper conditions and at the proper point. In addition, a description of the control of print speed to limit component heating is included at the end of the section.

### **4.4.1 Starting the Printing Operation**

The task of starting the print operation is handled in two steps. The first step is to prepare the DC305 to begin printing. This is done once for every print start. On the next and subsequent ticks, tests are run to see whether the carriage has arrived at the proper location to begin printing and that it is traveling at the proper speed. These tests are repeated until printing begins.

The forward printing process begins by obtaining the first character to be printed from the line buffer and loading its dots into the dot buffer. The first four sets of dots are then loaded into the FIFO of the DC305 chip and the dot interrupt is enabled and the carriage is started on the approach to the starting point of the print string.

The reverse printing process begins the same as that previously described, except that all operations are for backward printing. The right-most character in the line is loaded into the dot buffer.

Print start is enabled by a print start command that is stored by the DC305 chip and printing begins when the print head wires cross the boundary of the intercharacter space in either direction. To initiate a forward print start properly, the command must be given before the impact point crosses from the intercharacter space of the previous character into the cell of the character to be printed.

As a practical matter, the print start command is given only when the impact point is in the Safe Print Start Zone and the carriage is moving in the proper direction. The Safe Print Start Zone begins three transitions to the right of the left-hand cell boundary of the previous character and ends three transitions to the left of the intercharacter space of the same character cell as shown in Figure 4-4.

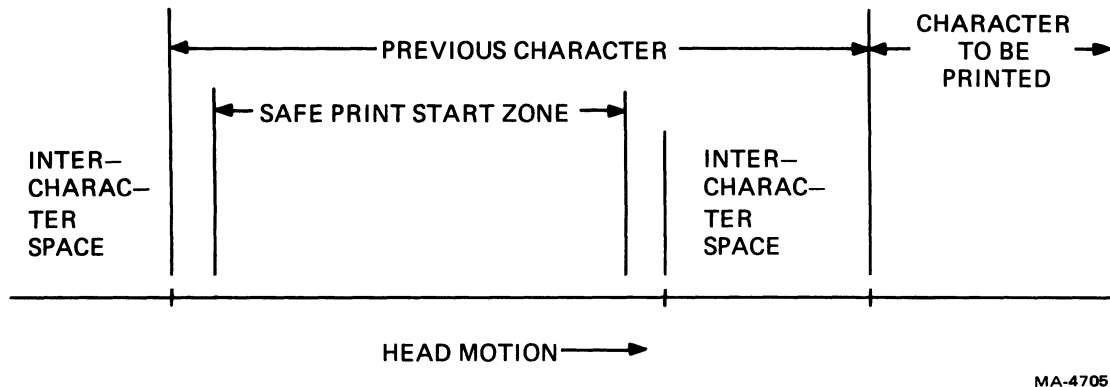

MA-4705

Figure 4-4 Forward Print Start

This scheme ensures that print start is only executed when the impact point crosses the left-hand cell boundary of the character to be printed. The scheme thus avoids premature print starts and print starts in the reverse direction that might otherwise be induced by unintended motions in the reverse direction. Such undesirable print starts would cause the characters printed subsequently to be displaced. Therefore, tests are made by the microprocessor to ensure that the carriage is traveling to the right at a speed that does not exceed the print speed by more than a small amount, that the impact point is in the Safe Print Start Zone, and that other conditions outlined below are met.

A number of tests must be made before forward printing may actually start. The first test is to see whether a vertical motion is in progress or pending, a cover is open, paper is out, etc. If any of these conditions are true, the routine is aborted. Next, the direction in which the carriage is traveling is checked. If it is negative, the routine is aborted; otherwise, the tests are continued by computing the maximum permissible approach speed as a function of the print speed limit currently in effect. Then the position counter is read and a projected impact point is computed. If the impact point is to the right of the Safe Print Start Zone, the carriage has overshot the mark and the routine is aborted. If the impact point is more than 255 transitions to the left of the right-hand border of the Safe Print Start Zone, the routine exits and no further tests are made during this tick interval since there is time to do the tests during the next tick interval. If the impact point is within range, the following tests are made:

1. A check that the carriage speed is less than the maximum allowed,
2. A determination that the impact point is less than 34 transitions to the left of the right-hand border of the Safe Print Start Zone,
3. A test that the print head is not likely to stop or change direction in the near future.

If any of the preceding tests are failed, printing cannot be started at the current tick time and the routine exits; otherwise, a go ahead for printing is issued and a final test is made to ensure that the impact point is to the right of the left-hand boundary of the Safe Print Start Zone. In the event that this test is failed, the routine aborts. If the test is passed, the print start command is given to the DC305 chip and the address of the Dot Service routine is set up in the dot interrupt service routine and the printing operation is finally begun.

The Safe Print Start Zone for a reverse print start is illustrated in Figure 4-5.

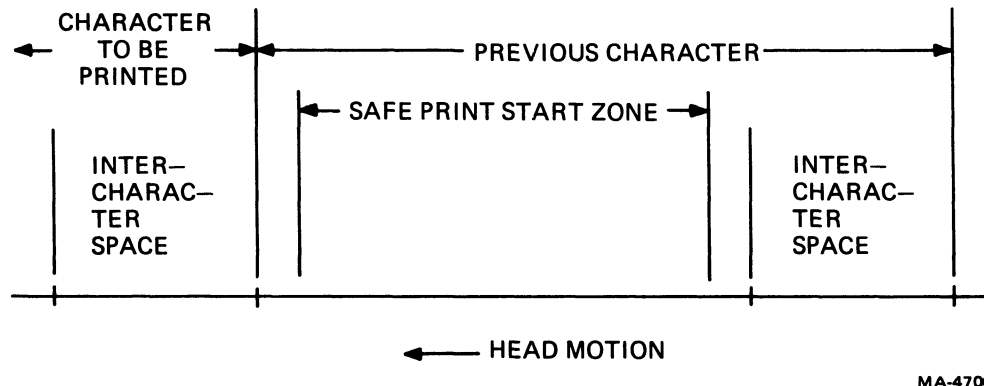

Figure 4-5 Reverse Print Start

The procedure for initiating a reverse print start is the same as that used for the forward print start, except that direction of motion is from right to left instead of from left to right.

#### 4.4.2 Flight Time Compensation

The flight time compensation procedure compensates for the fact that it takes approximately 400  $\mu$ s from the time the command is given to a solenoid to print a dot until the print wire hits the paper. If this command were to be given when the head is just at the point where the dot is to be printed and the head were traveling at 18 in/s, the dot would be printed 0.0072 inch past the intended point. If the next line were to be printed in the reverse direction, the characters would be displaced by a similar amount in the opposite direction, so that the characters in two successive lines would be very noticeably misaligned. It can be seen that the amount of compensation needed is proportional to the carriage speed. The faster the carriage moves, the earlier the wire has to be fired. Compensation is made by appropriate transition add or subtract commands sent to the DC305 printer controller. These commands cause one transition to be added or subtracted from the transition counter in the chip so that the command to fire is given to the solenoids before the intended print position is reached. The flight time compensation also compensates for some mechanical inaccuracies that are functions of print direction.

#### 4.4.3 Dot Rate Limiting

The LA120 will print reasonable text at a rate of 180 char/s indefinitely. However, heavy printing, such as many repetitions of the character “#” at 180 char/s without intervening spaces, will constitute an overload. The reason for this is that each dot represents a certain amount of energy that must be delivered and is eventually dissipated. If dots were printed too fast for too long a time, there would be heating of the head and certain power supply components. The longterm printing rate of the LA120, therefore, is limited to 2200 dots per second. The necessary speed limiting is performed on the basis of the recent printing history. The limiting function is a constant minus the integral of the difference between the dot rate and the maximum rate. A speed limit is computed from this function which is compared with the maximum permissible print speed for the current font. The lower of the two values is subsequently used to limit the printing speed. The scheme takes into account the thermal mass of the print head and of the power supply components and it allows heavy printing for a period of about 1 second. If the heavy printing continues, the print speed is reduced gradually until the dot rate is equal to 2200 dots per second.

## **4.5 CARRIAGE SERVO FIRMWARE**

The carriage servo firmware ascertains the current position of the carriage and generates the speed commands needed by the carriage servo to move the carriage to the position where it should be. Actual and desired positions are determined every time a tick interrupt is received, which is every 2.5 ms. The speed command given to the servo is then updated on the basis of these position determinations. This command is such that the carriage servo moves the carriage toward the desired position as rapidly as possible. As the carriage approaches the desired position, the speed is reduced to allow for a smooth stop.

### **4.5.1 Transitions**

The position of the carriage is measured by an incremental two-channel encoder mounted on the back of the carriage servo motor. Each channel has a square-wave output with 660 cycles per revolution, with the output of one channel leading the output of the other by 90 degrees. A transition is defined as the change of the output of one channel from the logic "0" level to the logic "1" level or vice versa. Thus, there are two transitions per cycle in each channel and since there are two channels there is a total of four transitions per cycle and 2640 transitions per revolution.

The motor moves the carriage 4 inches per revolution. Hence, there are 660 transitions per inch of carriage motion and

$$1 \text{ Transition} = 0.001515 \text{ inch}$$

The carriage servo routines are entered every time a tick interrupt is received. The tick interrupt is cleared and the actual position of the carriage is determined. Speed, flight-time correction, carriage position, and error are determined. A real-time clock is also incremented.

### **4.5.2 Reading the Position Counter**

Upon entry, the position counter in the DC305 chip is read. Interrupts are then enabled. The previous reading of the position counter is retrieved and subtracted from the current reading of the counter. The difference is stored for use in subsequent calculations. Since readings are made at fixed time intervals, this difference is a measure of the carriage speed. The value of the current counter reading is stored for use during the next tick interrupt service. This calculation is valid as long as the carriage did not move more than 127 transitions during the preceding tick interval.

### **4.5.3 Carriage Speed Command**

The determination of the command speed for the carriage servo is begun on the basis of how far the carriage is from where it is supposed to be. The actual target speed for the servo is obtained from a table lookup. This target speed is the speed input for subsequent routines where it is processed to generate the actual servo command. The sign of the target speed is chosen so that the carriage moves toward the point at which it is supposed to be and the target speed decreases as the carriage approaches its destination so that it arrives there at a reasonable speed.

In general, the speed command is based on the target speed unless the change from the previous target speed was too large. In that case, the acceleration limit is applied.

### **4.5.4 Error Conditions**

A speed error is computed by comparing measured carriage speed with the target speed. If this error exceeds a limit, it is an indication that the carriage is not moving as fast as it should and that it may, in fact, be stopped completely. If the error exceeds the limit for many ticks in succession, it is presumed that the carriage is stuck. This causes a pause flag to be set. Other pause flags are set when there is no paper or when the cover is open. Before a speed command is sent to the DC305, the pause flags are examined. If none are set, the speed command determined as previously described is sent. If any pause flag is set, a speed command of zero is sent.

## **4.6 COMMUNICATION FIRMWARE**

The LA120 controls transmission and reception of data on its serial interface by the use of the modem control lines to generate several full- and half-duplex protocols. SET-UP commands are used to fine tune the various protocols to suit the various modem and remote end requirements.

### **4.6.1 Communication Modes**

The LA120 has a wide range of communication modes, and while none are highly complex in themselves, their number and subtle differences can be confusing. There are two basic full-duplex modes and three half-duplex modes selected with the modem setup (M):

1. Full duplex without EIA controls
2. Full duplex with EIA controls
3. Half duplex - supervisory control
4. Half duplex - coded control, EOT
5. Half duplex - coded control, ETX

Other SET-UP commands affecting communication control are break enable (U), secondary channel (S), and auto disconnect (D).

### **4.6.2 Local Mode**

Whenever the terminal is in local mode, all modem signals are unasserted. No calls can be generated or received, and transmit and receive are disabled. All protocols except full duplex without EIA controls start at this level.

### **4.6.3 Disconnects**

Each of the following sections on full- and half-duplex modes define disconnects and the line functions that can cause them within each protocol. Additional disconnects can be caused by situations within the printer that cause printing to stop, such as paper out, cover open, or a head jam. Disconnect generation is a function of the SET-UP commands break enable (U), XON/XOFF (X), and auto disconnect (D) as shown in Table 4-10.

In all modes except M=1, a disconnect can be generated from the keyboard with a shift break. A long break disconnect is generated which unasserts all signals and puts a space on transmit data for 3.5 seconds.

### **4.6.4 Full Duplex Without EIA Controls**

This mode asserts DTR and RTS whenever the LA120 is on-line and ignores modem signals to the LA120. This mode, normally used for current loop, has receive and transmit enabled at all times while on-line. The break and speed/restraint function, as described in "Full Duplex with EIA Controls," are operational, but the disconnect functions are not.

### **4.6.5 Full Duplex with EIA Controls**

This mode supports a full modem interface requiring the following conditions to be satisfied in order to establish connection.

1. DSR must be asserted; then the LA120 asserts RTS.
2. RLSD must be asserted for at least 300 ms after DSR is asserted; then the LA120 enables transmission and reception.

This mode also provides automatic disconnect capability by use of the Data Terminal Ready signal.

**Table 4-10 Disconnect Generation vs SET-UP Commands**

SET-UP Commands		Action
Auto Disconnect (D)	Break Enable (U) and XON/XOFF Enable (X)	
D = 0	X = 1 U = 0 or 1	XOFF Sent
	X = 0 U = 1	Break
	X = 0 U = 0	No Action
D = 1	X = 1 U = 0 or 1	XOFF Sent, followed by Disconnect
	X = 0 U = 1	Disconnect
	X = 0 U = 0	Disconnect

**4.6.5.1 Full-Duplex Break** – A break can be generated manually by the break key or automatically by a printer fault condition such as paper out. In full duplex, a break consists of asserting a space on the transmit data line for 220 ms if transmission is enabled. If transmission is disabled, the break will remain pending until transmission is enabled or a disconnect is generated.

**4.6.5.2 Full-Duplex Disconnect** – In order to cause the modem to disconnect from the telephone line, DTR is deasserted for 80 ms. All signals are deasserted during this time, although it is the DTR signal that the modem recognizes as a disconnect. There are three types of line-generated disconnects:

1. Failure of either DSR or RLSD to assert within 20 seconds after the termination of a ring indication,
2. Failure of RLSD to assert within 5 seconds after DSR when initiating a call,
3. After connection is established the assertion of RI, deassertion of RLSD for 5 seconds or the deassertion of DSR.

In addition, an EOT received or transmitted with auto disconnect enabled will cause a disconnect. When disconnect is initiated by the transmission of an EOT, sufficient time is allowed for the EOT to be completely transmitted before the disconnect in order for the remote end to also disconnect. Also, a long space disconnect can be generated from the keyboard. This produces a space on the transmit data line and deasserts DTR for 3.5 seconds.



**4.6.5.3 Restraint Mode** – When a full-duplex mode is selected, the secondary channel setup (S=1) selects restraint mode. The secondary request-to-send signal is used to control the reception data in the same manner as XON/XOFF, although it cannot be controlled from the keyboard. This line is used to signal the remote end to stop sending characters in order to keep the input buffer from overflowing due to the receive character rate or a print stop condition (paper out, cover open, etc.). The remote end must maintain the proper signals to have receive enabled before using the restraint line to control data transmission.

**4.6.5.4 Speed Control Mode** – The speed control function is selected with SET-UP S=0 in a full-duplex mode. While in this mode, the LA120 indicates its selected speed on the speed select line. The signal is asserted if the operator-selected baud rate is 1200 or higher. This allows a high speed call to be initiated from the LA120 without manually setting the high speed button on the modem.

Also, the LA120 will reset its operating baud rate to 1200 baud if the speed indicator signal is asserted. The 1200 baud rate is forced only as long as the line is asserted and does not affect the operator-selected (displayed) baud rate.

#### **4.6.6 Half Duplex**

Due to the “one at a time” definition of half duplex, elaborate protocols (compared to full duplex) are needed to define who should transmit at any given time. Each time the transmitter and receiver switch functions, the line is “turned around.” This basically consists of switching the end of the line that asserts RTS, which reverses the transmit/receive mode of the modem and switches the carrier generation from one end to the other. Also, when echo suppressors are on the line, it is necessary to turn them around in order to attenuate in the opposite direction. The LA120 incorporates three methods of controlling line turnaround. In supervisory control mode the host controls all line turnarounds by manipulating the secondary control lines. Reverse channel is mandatory for this mode. The two other protocols (coded control with reverse channel and coded control without reverse channel) allow the transmitting device to control line turnaround via specific control characters. If reverse channel is used, these lines provide confidence as to the fate of the transmitted data. Without these signals, the transmission is “blind.”

**4.6.6.1 Initial Direction Determination** – When the LA120 is initially put on-line (or at power up), data can be neither transmitted nor received. When the terminal is called, RI will assert before DSR. In auto answer mode, most modems answer the call (go off hook) before asserting DSR. However, some modems allow DSR to assert after a couple of rings but before the call is answered. With this sequence, the terminal attempts to establish receive mode. If the terminal operator is initiating the call, DSR asserts when the modem is placed in data mode. Since DSR is asserted without RI, the terminal attempts to enter transmit or receive mode, depending on the HDX initial state SET-UP command. If the terminal attempts to enter receive mode and RLSD is not asserted within 5 seconds, the normal timeout disconnect occurs.

**4.6.6.2 Reverse Channel** – The reverse channel transmits supervisory or error control signals. These signals flow in the opposite direction to which data is being transferred. Due to the relative lower bandwidth of the reverse channel (to the forward channel), it is not used for data exchange.

**4.6.6.3 Request to Send Delay** – As noted in the RLSD definition, the analog loopback option turns around certain lines to the LA120:

1. RTS asserted causes RLSD to be true.
2. SRTS asserted causes SRLSD to be true.
3. Receive data mimics transmit data (local copy).

For this reason, whenever RLSD or SRLSD is to be used, 300 ms must have lapsed since the local driving force (RTS, SRTS) has been removed. Up until that time the signals do not represent the remote end.

Also, RTS cannot be lowered until the last character is completely serialized (transmit complete).

**4.6.6.4 Turnaround Characters** – The turnaround characters (EOT or ETX) initiate the line turnaround when received or transmitted. To eliminate the need for the operator to generate the turnaround control code, the LA120 automatically sends the control code after RETURN or ENTER key is typed, after sending the normal code for that key.

**4.6.6.5 Half-Duplex Break** – A break can be generated manually by the BREAK key or automatically by a printer fault condition such as paper out. There are three cases of break processing in half duplex:

1. Transmit mode (RTS true) – The break is transmitted as a space on the transmit data line for 220 ms.
2. Receive mode (RTS false) – The break is transmitted as a space on the SRTS line for 220 ms. When operating with “coded-no reverse channel,” the break is ignored when in receive mode.
3. While switching modes – If neither receive nor transmit is enabled, the break will not be processed until a definite line direction is established.

**4.6.6.6 Half-Duplex Disconnect** – Hanging up the telephone to disconnect from the line is accomplished by dropping DTR for 80 ms and resetting all control lines to their initial state.

There are five line conditions that will cause a DTR disconnect:

1. Failure of either DSR or RLSD to assert within 20 seconds of the termination of a ring indication.
2. Failure of SRLSD to assert within 5 seconds after DSR, when initiating a call with reverse channel.
3. Failure of a line turnaround to complete within 5 seconds.
4. In coded control, deassertion of RLSD or SRLSD for 5 seconds without the turnaround character. (If no reverse channel, only RLSD is monitored.)
5. After a valid line direction is established, the assertion of RI or the deassertion of DSR.

In addition, a command can be used to initiate a disconnect. An EOT or DLE-EOT from the keyboard or line will disconnect the line. If EOT is used as the turnaround character, DLE-EOT is used as the disconnect command. When a disconnect is initiated from the keyboard, the EOT or DLE-EOT is sent to the remote end before the disconnect in order for the remote end to also disconnect. Also, a long break disconnect can be generated from the keyboard. This produces a space on the transmit data line and drops DTR for 3.5 seconds.

#### **4.6.7 Communication State Control**

The communications firmware consists of three modules and various pieces of code in other modules. The controlling module is the communication handler that decodes the communication state table to generate the protocols. The third dedicated module is the input scanner, which scans the input data stream for characters that affect the communications protocol. These modules operate at tick level and are always monitoring and updating the communication operation.

**4.6.7.1 Communication State Table** – This table consists of encoded input and output conditions that reflect the protocol diagrams presented in a following section. Inputs consist of signal values from the communication line (DSR, CD, etc.) and terminal functions (break request, etc.). Outputs are signals that the LA120 can assert (DTR, RTS, etc.) and terminal control (transmit disable, etc.). There is also a real-time clock output (set timer) and input (time expired) that allows timing of functions in the range of 20 ms to 90 seconds. Timed functions include breaks, turnarounds, etc.

Each set of input and output conditions is considered a state. When a state is entered, the outputs for that state are invoked, providing a strict definition of the communication line at that time. These outputs are held until one of the inputs associated with that state is of the desired value, at which time the pointer associated with the input is used to access a new state and new outputs are generated. These states are linked in such a manner as to generate the various protocols.

The conditional branch entry is an addition to the state table entries. This type of entry does not generate new outputs, but allows the linkage of states (and thus the protocol) to be modified according to various SET-UP conditions. This ability to branch on SET-UP conditions allows communication states to be shared between protocols. An example is that most protocols use the same series of answer states and then branch after a connection is established to implement the actual protocol.

**4.6.7.2 Communication Handler** – The main function of the communication handler is to implement state transitions as defined in the state table. There are also some functions that are always present (or almost) and, therefore, are not carried in each entry of the table, but are handled as a parallel function in the communication handler code. The communication handler is broken down into two execution blocks that run at tick level. Each block is called alternately by the LA120 scheduler every four ticks, generating a total pass of the handler in 20 ms. In addition to these two blocks, there is the initialize section of code that is called at power-up and when communication affecting setups is changed. The functions included within the handler are:

1. Control LINE/LOCAL, DSR, and CTS keyboard lights
2. Gather inputs for table exit conditions
3. Control timer
4. Check for disconnects
5. Speed/restraint for full duplex
6. Compare exit conditions to valid exits for the state
7. Invoke new state outputs
8. Detect and process branch table entries.

**Break Processing** – Breaks are received via a break request flag, set outside the communication handler due to keyboard action or a printer fault condition such as paper out. The break request is passed to the exit condition inputs if breaks are enabled and is implemented by a series of normal state transitions if the selected protocol uses breaks.

**Disconnect Processing** – A disconnect request flag is set outside the communication handler if the appropriate code is received or transmitted, or a printer fault condition such as paper out occurs and auto disconnect is selected. Disconnects are implemented by starting the protocol at its initial state after any pending XON/XOFFs are sent. By forcing the initial state, modem SET-UP 1 (full duplex without EIA controls) will not perform a disconnect because its initial state is with modem signals asserted, although internal initializations, such as resetting the USART, will occur. For this reason, it is always recommended to be sure that auto disconnect is not selected when using modem SET-UP 1.

A long break disconnect request causes a special state to be entered for the 3.5 seconds, then exited to the initial state for the protocol in effect.

**Turnaround Processing** – A turnaround request flag is used by the coded control protocols to initiate a line turnaround. The flag is set outside the communication handler by reception or transmission of the appropriate control code for turnaround. This flag is placed into the input byte and is available as an exit condition to be used if the protocol in effect uses turnaround characters. The flag is reset by the communication handler.

**Timer** – The communication handler contains a software timer that can be set by an output value from the state table. Each state that sets the timer carries an extra byte to define the duration. When the countdown timer has expired, a bit in the input byte is set that can be tested as an exit condition and the necessary states can be started to process the timeout. All time values mentioned in the state diagram are implemented using this timer.

**SRTS Flag** – The SRTS flag is a byte containing the value of secondary request to send when in full duplex. This byte is always ORed with the outputs from the table to set SRTS when a function outside of the table (speed/restraint) needs to control that signal. The state outputs never assert SRTS while the SRTS flag is controlling SRTS; when the table is controlling SRTS, the SRTS flag is always zero.

**Restraint Processing** – The restraint function is implemented if in full duplex and secondary channel (S=1) is selected. If any of the appropriate printer pause conditions are true, the SRTS flag is set and a new value sent immediately.

**Speed Indicator/Select Processing** – Speed information is sent to the modem if in full duplex and SET-UP S=0. The operator selected baud rate is used to define the value for the signal sent using the SRTS flag and an immediate output.

Speed select to the LA120 is implemented whenever the value of secondary carrier is changed during full duplex with SET-UP S=0. When this occurs, the proper baud rate is generated according to the new value of the secondary carrier.

**Branch States** – These entries in the table do not generate any new outputs, but can change the state pointer according to the value of the following setups:

1. Full duplex
2. Coded control
3. Supervisory channel
4. HDX initial state.

These conditional branch entries contain an index value that is used to generate the address of a routine that will test the appropriate SET-UP status. If the routine returns with the zero bit set, the address contained in this entry is used as the next state to go to, and generates those outputs.

**Auto Answerback** – This function allows the answerback message to be sent the first time the terminal is transmit-ready after establishing a valid connection. When the transmitter is enabled, a flag is checked to see if it is the first time; if so, the answerback message is sent.

#### 4.6.8 Control Code Generation and Detection

**4.6.8.1 Input Scanning** – The input scanner runs at tick level and scans the input buffer for characters that are relevant to the communication functions. The scanner looks for EOT, DLE-EOT, and ETX and sets the appropriate flag for the current operating mode of the LA120. The scanner keeps its own pointer and is asynchronous to the normal input buffer processor. The scanning was deemed necessary due to possible latencies in normal character processing when the buffer is full.

**4.6.8.2 Transmit Scanning** – Characters that have communication meanings are also scanned in the transmit routine. The same characters are checked and processed as in the input scanner, but it is done as each character is sent. Control codes that effect communications are never echoed within the terminal. The transmit routine also refreshes the USART command, sometimes generated by the communication handler.

**4.6.8.3 Control Code Generation** – Control codes generated from the keyboard are sent and scanned normally. When a half-duplex coded control protocol is selected, the appropriate turnaround character is built into the carriage return transmit string to relieve the operator of this code generation. These “automatic” codes are detected in the normal manner.

#### 4.6.9 Functional State Diagrams

This section contains diagrams (Figures 4-7, 4-8, 4-9, and 4-10) that define the status of the communication signals and functions at any one time and what causes a change from one state to another. The communication state table is encoded from these diagrams.

In these figures, a state is an area of an ON and/or OFF function. These areas relate to which signal is changed and to what value. Only the signals specifically set/reset within a state are affected. The N/C state is one that has no change to the outside world but the exit conditions are now different.

Each exit path from a state has an associated condition typed next to it. If this condition is true, the path is taken and the next state entered. Those exit paths with more than one condition require all conditions to be true unless specifically separated by “OR.”

The half duplex diagrams contain Note A and Note A1.

Note A is not a state but a branch of the form shown in Figure 4-6.

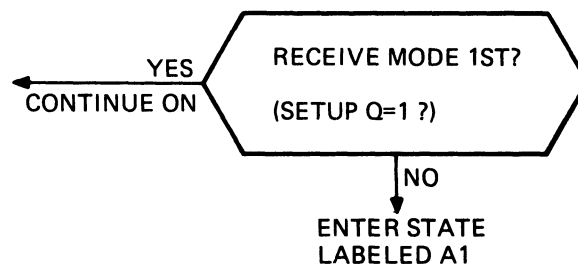

MA-4701

Figure 4-6 Note A Branch Form

Note A1 identifies the state entered after originating a call and the operator has selected to enter receive mode first.

As noted earlier, there are functions in parallel to the state diagrams such as disconnect request, line/local, etc.

The fundamental flow is clockwise when turning the line around in half duplex. When put on-line, the OFF 1, 2, 3 state is entered, requiring either RING or DSR in order to exit the state.

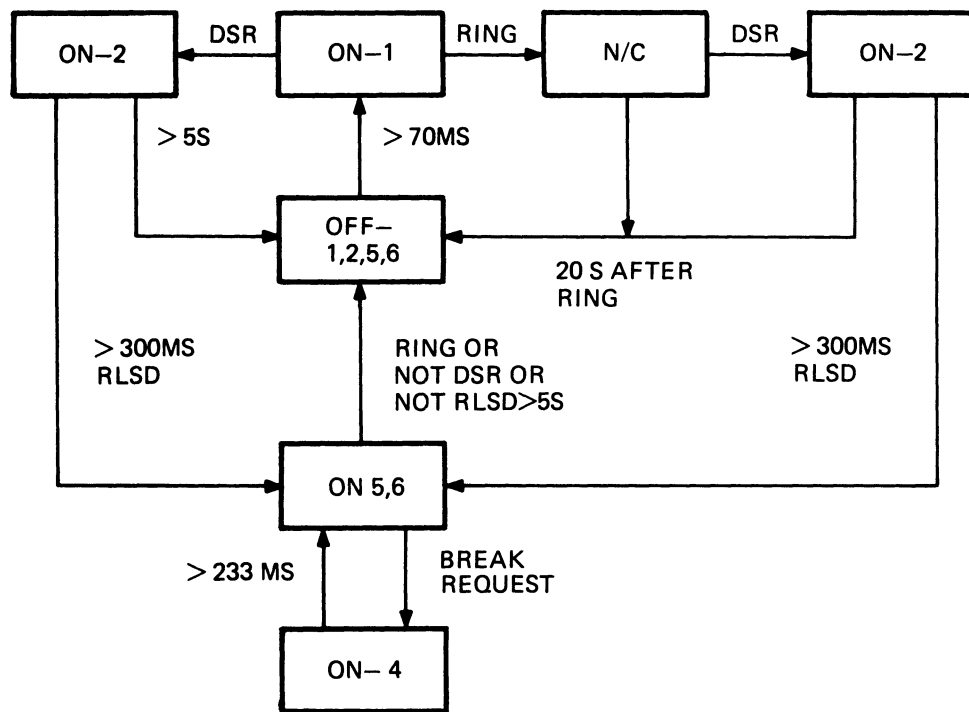

KEY: 1) DTR 3) SRTS 5) RECEIVE N/C CHANGE  
 2) RTS 4) SPACE XMIT 6) XMIT

MA-4697

Figure 4-7 Full Duplex

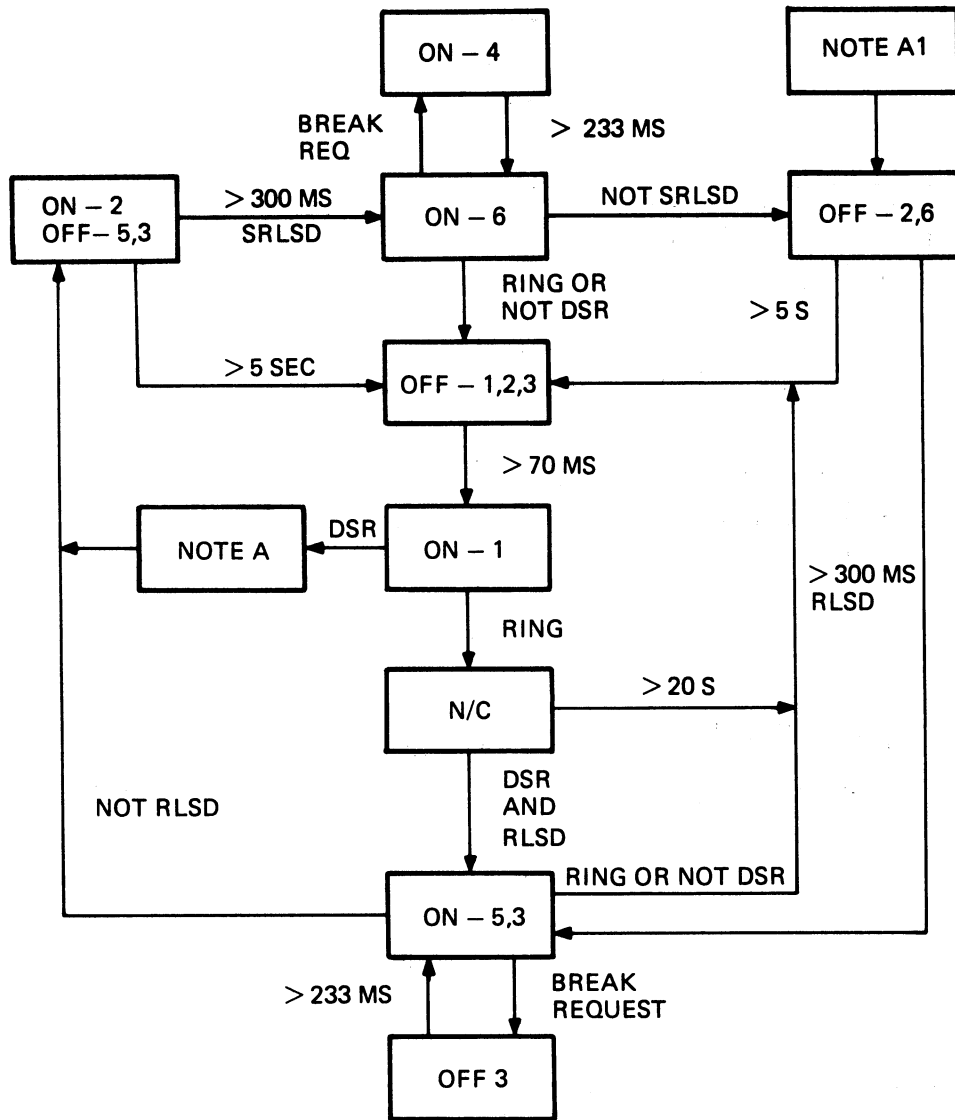

KEY: 1) DTR    3) SRTS    5) RECEIVE    N/C) NO CHANGE  
 2) RTS    4) SPACE XMIT    6) XMIT

MA-4696

Figure 4-8 Supervisory Control

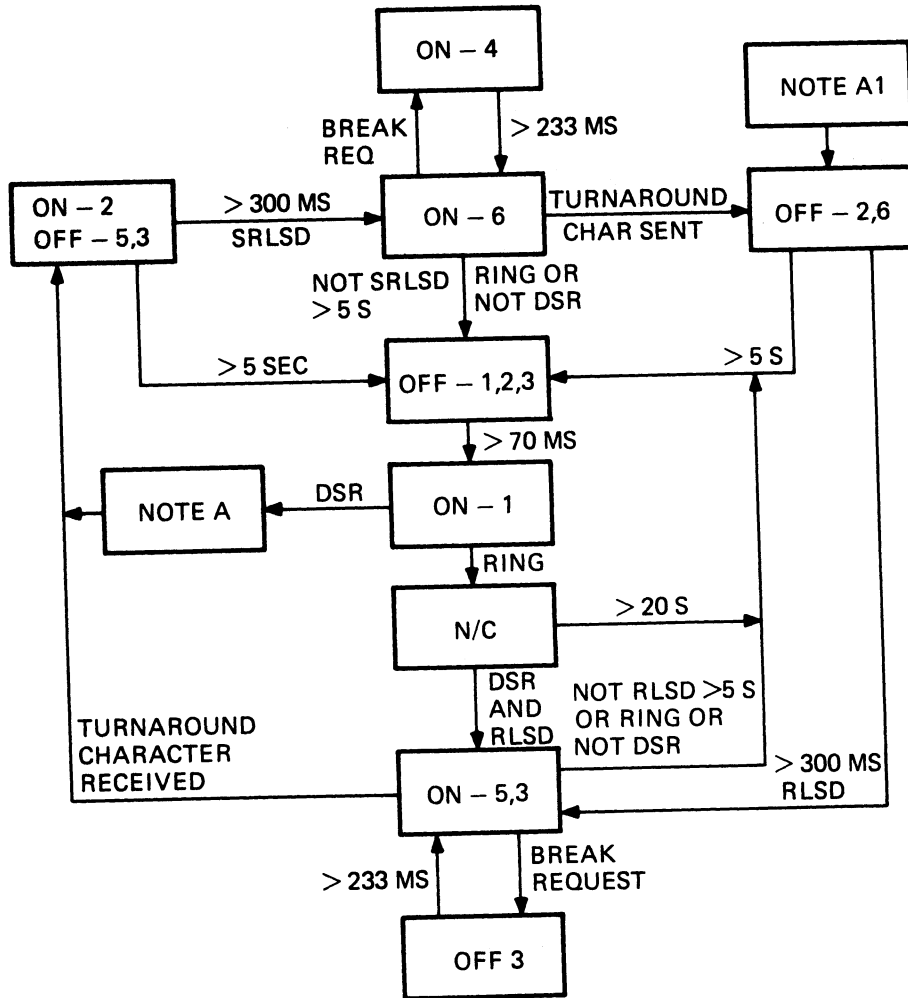

KEY: 1) DTR 3) SRTS 5) RECEIVE N/C) NO CHANGE  
 2) RTS 4) SPACE XMIT 6) XMIT

MA-4700

Figure 4-9 Coded Control with Reverse Channel



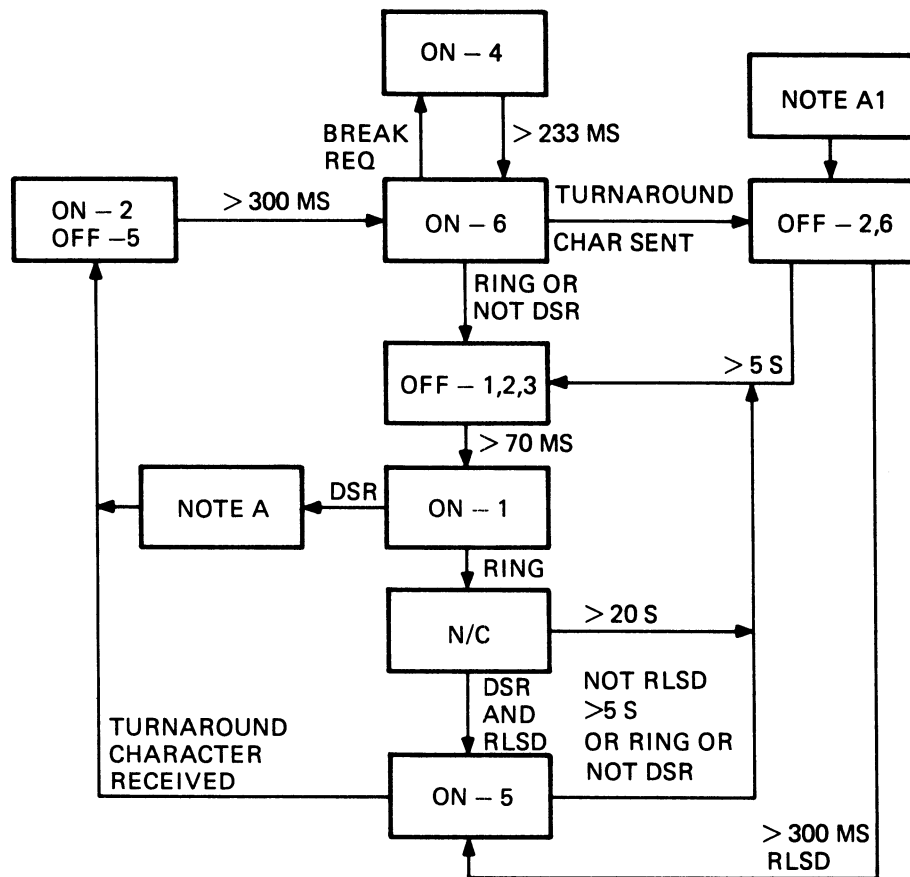

KEY: 1) DTR 3) STRS 5) RECEIVE N/C) NO CHARGE  
 2) RTS 4) SPACE XMIT 6) XMIT

MA-4698

Figure 4-10 Coded Control Without Reverse Channel

## 4.7 ESCAPE SEQUENCE PROCESSING

Escape sequences are processed by a table-driven parser. There are two major tables that are used in parsing escape sequences, a state transition table and a jump table.

### 4.7.1 Escape Sequence State Transition Table

The escape sequence state transition table consists of seven individual tables or elements numbered 1 through 7. At any given time, there is a pointer in RAM that points to one of the elements in this table.

Each element of the table is used (at different times) to scan the next character in an escape sequence. Basically, each element consists of one or more entries containing the following items:

1. The character against which the input character is to be compared (either for an exact match or lower than or equal for a “range” test).
2. A pointer to the next state transition table element to be used to test the next character of the escape sequence if the test in item 1 succeeds.
3. An index into a jump table that provides the address of a routine to be executed if the test in item 1 succeeds.

These entries can be broken down into two different types within each element of the table, depending on how the first byte of the entry is used.

1. The first byte of a table entry can be used to test for an exact match.
2. The first byte can be used as a “range” test. The range is satisfied if the input character from the escape sequence is less than or equal to the first byte of the table entry.

All of the exact match table entries come first in the table element, and can be in any order (but are arranged in ascending order for ease of maintenance.) The range tests come last in the element, and must be in ascending order. The last entry in each element is a range test entry for octal code 377 to force all of the remaining illegal characters through the parser. The two types of entries in each element are separated by a zero byte. Figure 4-11 illustrates how the entries can be organized within each of the table elements.

#### NOTE

**The second type of element may have no exact matches, so it starts out with a mid-table separator (zero byte).**

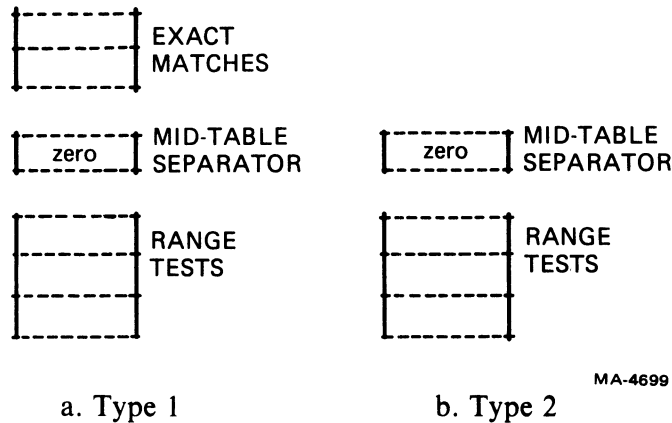

Figure 4-11 Entry Organization Within a Table Element

**4.7.1.1 Element No. 1** – This is always the first table used in parsing an escape sequence. The parser is initialized to this element after a valid escape sequence has been parsed, whether the LA120 actually performs the designated function, or just skips over it. Prior to using this first table element, the background executive routine has detected the first escape character denoting the start of an escape sequence, and sets a flag so that any printable characters that follow will be routed to the parser. This first element does the following functions:

1. Strips out the escape sequences that are used to designate a G0 graphic set by finding the left parenthesis (octal code 050) after the initial escape character, and sets the pointer to element no. 7 to parse the next character anticipated in these sequences.
2. Jumps to the appropriate action routines required to process each of the 2-character escape sequences after finding the final character.
3. Strips out the 2-character escape sequences single shift 2 (SS2) and single shift 3 (SS3) and the pointer to element no. 2 to parse the next character anticipated in these sequences.

**NOTE**

**SS2 and SS3 are nonlocking shift-outs to predefined graphic sets (like the S0 control code), but only apply to the next character in the sequence, then automatically shift back in again. Since the LA120 does not support SS2 and SS3, it simply skips over the next character.**

4. Detects the start of four different types of control strings: device control string (DCS), operating system command (OSC), privacy message (PM), and application program command (APC). It sets the pointer to element no. 3 to parse the next character anticipated in these sequences.

**NOTE**

**All control strings must be terminated by a string terminator (ST), which consists of another escape character followed by a backslash. Since the LA120 terminal does not support any control strings, it skips over all of this.**

5. Detects the start of a control sequence introducer (CSI), and sets the pointer to element no. 5 to parse the next character anticipated in this type of sequence. It also prepares to accept multiple decimal input parameters.

**NOTE**

**CSIs (in 7-bit mode) consist of the escape character followed by octal code 133 (left square bracket in US/UK), a number of multidigit decimal parameters separated by octal code 073 (semicolon), and terminated by a final character (octal codes 100–176).**

6. Strips out all intermediate characters (octal codes 040 to 057), with the exception of 050 (left parenthesis), which is used when designating graphic sets; and sets the pointer to element no. 4 to process the next character anticipated in these sequences.

**NOTE**

**The LA120 terminal does not support any three-character (or longer) escape sequences that use intermediate characters except as previously noted.**

7. Any other character received while in element no. 1 must be a final character. It is considered to be a valid 2-character escape sequence not implemented on the LA120. [By default, this also includes a string terminator (ST) not immediately preceded by a control string.] Therefore, the current sequence is considered complete, and the parser is reinitialized.

**4.7.1.2 Element No. 2** – This table element unconditionally skips the next character in the current escape sequence, after which it reinitializes the parser. It is entered after encountering the start of a single shift 2 (SS2) or single shift 3 (SS3) in element no. 1 or the start of a string terminator (ST) in element no. 3.

**4.7.1.3 Element No. 3** – This table element is entered after finding the start of one of the four types of control strings (DCS, OSC, PM, or APC) in element no. 1. It unconditionally skips all input characters, both intermediates and finals, until an escape character is encountered signifying the start of a string terminator (ST). When the escape character is eventually found, it sets the pointer to element no. 2, which will skip over the final character of the string terminator. It also prevents the background executive routine from sending another escape character.

**4.7.1.4 Element No. 4** – This table element is used to finish parsing an escape sequence in which an unexpected intermediate character was encountered before the final character. It can be entered from element no. 1 or element no. 7. It skips over any more intermediate characters until a final character is found, after which it reinitializes the parser.

**4.7.1.5 Element No. 5** – This table element is used to process a control sequence introducer (CSI). It is originally entered from element no. 1 after an escape character followed by a left square bracket (octal code 133) has been encountered. The remainder of the CSI escape sequence will “loop” in this table element until either the final character is found, or an error condition is detected. Errors are considered to be characters in the octal code range of 072 to 077 (for example, a question mark or colon); or an intermediate character (octal codes 040 to 057). Errors will cause the pointer to be set to element no. 6 to properly complete the parsing of this type of escape sequence.

ASCII digits that are encountered are considered to be part of a decimal parameter, and are appropriately processed. Semicolons that are found here are separator characters used between the parameters, and are so processed.

If a final character is received by this table element, it jumps to the associated “action” routine. After the final character “action” routine has completed, the parser is reinitialized.

**4.7.1.6 Element No. 6** – This table element is entered after finding an illegal character while processing a CSI in element no. 5. The purpose of this table is to properly complete the parsing of this type of escape sequence by skipping all additional characters until a final character (octal codes 100 to 176) is found, after which the parser is reinitialized.

**4.7.1.7 Element No. 7** – This table element is entered from element no. 1 after finding the start of a Designate G0 Graphic Set escape sequence, which is an escape character followed by a left parenthesis. If an additional intermediate character is found, the pointer will be set to element no. 4 to finish parsing the remainder of the sequence correctly. If a final character is found corresponding to one of the national character sets supported by the LA120, this table element will cause a jump to the “action” routine that changes the printer character set. If any other final characters (octal codes 060 to 176) are encountered, they will cause the parser to be reinitialized.

#### **4.7.2 Escape Sequence Jump Table**

The second major table used in parsing escape sequences is the escape sequence jump table. It consists of a number of entries containing the addresses of routines to be executed when an exact match or range test is satisfied by one of the table entries in one of the seven elements of the state transition table. It is these routines that do the actual “work” required by the escape sequence, such as changing variables, setting flags, etc.

#### **4.7.3 Escape Sequence Parser**

The parser is the set of routines that does the parsing or breakdown of an escape sequence. Three routines control the logical flow of parsing an escape sequence:

1. The routine that begins the parsing of escape sequences.
2. The routine that initializes the parser.
3. The routine that controls the flow through the state transition tables.

**4.7.3.1 Begin Parsing** – The begin parsing routine is called by the background executive routine that is normally processing characters when it finds the first escape character that denotes the start of an escape sequence. This routine starts the parsing routine by setting a flag that causes subsequent printable characters to be routed to the parser until the escape sequence has been terminated properly.

#### **NOTE**

**Even though the parser is enabled, control characters (octal codes 000 to 037) are skimmed off and acted upon, and never get to the parser. With the exception of device control strings (DCSs), if another escape character is received before the current escape sequence has completed, the current escape sequence is aborted and a new escape sequence will be started with the second escape character. This is handled outside the parser by the executive routine.**

**4.7.3.2 Initialize Parser** – The initialize parser routine reinitializes the escape sequence parsing mechanism to start a new escape sequence as soon as the background executive routine encounters the next escape character. This routine only does two things: it resets the parser flag (see Begin Parsing, Paragraph 4.7.3.1) and it resets the state table pointer to element no. 1.

This routine is called under the following circumstances:

1. During power-up initialization.
2. After an escape sequence has been properly terminated or completed.
3. When a cancel or substitute character (or delete character in local mode) is encountered in the input stream [(or when another escape character is encountered if not processing a device control string (DCS)].

#### NOTE

**The substitute character may be generated internally if a communications error is detected. Terminating an escape sequence when an error is encountered prevents the terminal from hanging in a nonprinting state.**

**4.7.3.3 Flow Controller** – The flow controller is a very short routine. The reason for this is that the majority of the escape sequence parsing logic is contained in the state transition tables.

The flow controller consists primarily of two table look-up routines. When it is entered, the state pointer is pointing to one of the seven elements of the state transition table that has been assigned to examine the next (or first) character anticipated in the current (or next) escape sequence. The first of the two table look-ups is looking for an exact match against the input character. This look-up is terminated by either a “hit” (i.e., an exact match), or by finding the “mid-table” separator, which is a zero byte.

If the mid-table separator was encountered first because there was not an exact match, the flow controller then proceeds to the second table look-up. The second table look-up is similar to the first table look-up, except that a “hit” is considered to be any input character that is lower than or equal to the first byte of a table entry. These “range test” table entries are in ascending order and are constructed so that all input characters will get a “hit,” including all erroneous ones.

Having gotten a “hit” with the first byte of a table entry from one of the seven escape tables, either as the result of an exact match or a range test, the flow controller picks up the new pointer value from the “matching” table entry. This designates the proper table element to use for the next character in the escape sequence.

Next the flow controller picks up the jump index from the “matching” table entry, uses it to index into the jump table, and jumps to the appropriate “action” routine.

#### **4.7.4 CSI Parameters**

The rules for CSI escape sequences allow any number of parameters: but in the LA120, only the last 16 are saved. Of the 16 (or less) that remain, they are processed in first-in, first-out (FIFO) order.

#### **4.7.5 Control Strings**

The following escape sequences are considered control strings: device control string (DCS), operating system command (OSC), privacy message (PM), and application program command (APC). The LA120 does not support any control strings, but it will parse them correctly and skip over them. When parsing control strings, the background executive routine will pass an escape character through to the parser which it would not normally do. The escape character is needed to terminate the control string.

#### **4.7.6 Final Character Perform-Function Routines**

The actual performance of an escape sequence must wait until the “final” character has been received, parsed, and interpreted before the actual desired function can be performed. The final character action routines contained in the LA120 follow:

- Horizontal Tab Set
- Vertical Tab Set
- Clear Horizontal Tab at Active Column
- Clear Vertical Tab at Active Line
- Clear All Horizontal Tabs
- Clear All Vertical Tabs
- Enter Alternate Keypad Mode
- Enter Normal Keypad Mode
- Index Down One Line
- Next Line
- Horizontal Position Absolute
- Horizontal Position Relative
- Device Attributes (Product ID)
- Vertical Position Absolute
- Vertical Position Relative
- ANSI Tab Clears (0–4)
- Set Mode (LNM)
- Reset Mode (LNM)
- Set Top and Bottom Margins
- Set Left and Right Margins
- Set Number of Lines Per Page
- Set Multiple Horizontal Tabs
- Set Multiple Vertical Tabs
- Set Horizontal Pitch (char/in)
- Set Vertical Pitch (lines/in)
- Designate G0 Graphic Set

### **4.8 SET-UP COMMAND PROCESSING**

SET-UP commands allow many features of the LA120 terminal to be controlled by the operator via the keyboard. Rather than requiring the operator to enter a myriad of “free-form” commands with all of the attendant checking that would be required by the firmware, it was decided to present the operator with a list of only the valid choices. Thus, the requirement of having to validate free-form commands was totally eliminated. The method chosen to present these selections was to display them sequentially in the 4-digit, 7-segment display. The last choice displayed is the current selection. Entering an invalid SET-UP command will cause the audible alarm to sound.

#### **4.8.1 SET-UP Command Implementation**

To perform a SET-UP command, the operator must first place the LA120 in SET-UP mode using the SET-UP key with or without the control key. While in SET-UP mode, the SET-UP LED indicator will be flashing to confirm that the terminal is in SET-UP mode. In SET-UP mode, most of the keys on the keyboard can be used to perform SET-UP commands.

While in SET-UP mode, printable characters go to the SET-UP routines, and control characters are routed to the printer. SET-UP commands fall into two general categories:

1. Multiple choice SET-UP commands, and
2. Immediate action SET-UP commands.

**4.8.1.1 Multiple Choice SET-UP Commands** – If a SET-UP command has multiple choices, executing the SET-UP command the first time displays the current setting of that function without changing it. Executing the same SET-UP command a second or subsequent number of times without leaving SET-UP mode (which is defined as releasing or unlocking the SET-UP key) will cause the display to cycle through, one at a time, all of the valid choices for that command. After reaching the end of the selection list, the display will recycle and start over again from the beginning.

The alphabetic keys (“A” to “Z” in US/UK) are used to perform multiple choice SET-UP commands, with the exception of “I” (Initialize) and “T” (printing self-Test). Alphabetic SET-UP commands work the same, whether shifted or unshifted. Multiple choice commands are broken down into two logical groups. All of the members of one group only have two choices. The number displayed in the display is either a zero or one, which in general means that the selected function is either disabled (0) or enabled (1). The flags for these commands are stored as consecutive bits in RAM.

Multiple choice commands with more than two possible selections use an entire byte to store their current setting. The value displayed is usually the value of this “index” byte plus one. These indices are stored in consecutive bytes in RAM. There are four exceptions to displaying the index value plus one. They are:

1. Receive Baud Rate (SET-UP 0)
2. Transmit Baud Rate (SET-UP Shifted 0)
3. Horizontal Pitch or char/in (SET-UP H)
4. Vertical Pitch or lines/in (SET-UP V)

Since the values being selected by these commands are displayable as decimal integers (suitably rounded in the case of some horizontal pitches), these values are displayed instead of the index numbers. For example, if the “H” SET-UP command results in a display of “10,” that means 10 char/in, not the tenth choice in the list. Similarly a SET-UP “0” display of 1200 means a receive speed of 1200 baud.

**4.8.1.2 Immediate Action SET-UP Commands** – In an immediate action SET-UP command, the operator is not concerned with the current setting (if any). The operator just wants the terminal to do something immediately. For example, to start the printing self-test, the operator uses SET-UP “T.” Sometimes the active position is an implied input to the action routine, such as in setting a horizontal tab stop (SET-UP “1”). The top row of the keyboard is assigned to the immediate action commands with the exception of SET-UP “0” (receive baud rate) and SET-UP shifted “0” (transmit baud rate), which are multiple choice.



Normally, the 4-digit, 7-segment display will contain the column number of the next character to be printed. However, if the SET-UP key is pressed (or locked) and the SHIFT key is also pressed, it will contain the current line number. For this reason, all vertical tab and margin commands have been implemented as shifted. This makes them easier for the operator to set up. If the TOF (top-of-form) command (SET-UP 4) is done shifted (and the top margin is clear), the operator will see the current line number change to "1."

The nonprinting self-test (SET-UP shifted >) was assigned to the greater than character because on both the US/UK and all other foreign keyboards this character has to be shifted to be entered, thus reducing the likelihood of accidentally triggering this seldom-used command. The request for current status message (SET-UP 8) cannot be entered shifted. This was done to eliminate some possible firmware interactions concerning the display that would have required additional ROM to solve. The status message is "semi-recursive," and is described separately below.

The SET-UP routines also respond to numeric codes from the optional keypad, since the SET-UP commands are defined by code rather than key position. The following three keys are independent of SET-UP mode: LINE/LOCAL, LOCAL FORM FEED, and LOCAL LINE FEED. The HERE IS key is also controlled by the keyboard handler.

#### **4.8.2 SET-UP Handler**

Whenever the operator enters SET-UP mode, the background executive program invokes the SET-UP handler for each character of the command whose octal code is greater than 040 (the space character) and less than 177 (delete/rubout). If the character received is not from the US/UK keyboard, the SET-UP handler translates the character into a code it would have received if the key had been struck on the US/UK keyboard such that top row SET-UP commands, whose legends appear on the trim strip, do not change position from character set to character set. Alphabetic SET-UP commands are not translated, so they are always identified by letter, not by key location.

The SET-UP handler's tables handle only octal codes 041 through 137 (which includes the uppercase letters). Octal codes 140 through 176 (which include the lower case letters) are translated to the 041 through 137 codes. This is done to make the SET-UP commands independent of the SHIFT key or the CAPS LOCK key. For example, the small letter "a" is translated to the uppercase "A."

The SET-UP characters are now used to access the first level command table. This table contains information that identifies the class of SET-UP commands to which this command belongs. It is possible that no SET-UP command at all is associated with this character (identified by a zero byte in the table), in which case a bell is rung. Otherwise, the command will select one of several general-purpose subroutines. Similar SET-UP commands that are in the same category are handled by the same subroutines. Basically there are:

1. groups of commands that are on/off or 1/0 operations,
2. groups of commands that are multiple choices (like baud rates of 300, 600, 1200, etc.), and
3. groups of immediate action commands that do not alter parameters at all (like self-test, save/recall, set tabs, etc.). These do not show results on the LED display.

Once the SET-UP command has identified the type of action, subroutines are called to implement the action. If the command is one of the on/off or multiple-choice type, then the subroutine determines whether the character has been typed once or several times in a row during this SET-UP sequence. The first time a SET-UP command is typed, the value of the parameter's current setting is displayed. Upon repeats of the command, the value of the parameter is altered and displayed on the LED display. For each type of SET-UP command, there is a subroutine that handles the first input of the command and a subroutine that handles subsequent SET-UP change commands. Finally, certain SET-UP commands need to call an initialization subroutine every time the SET-UP command parametric value has been altered (like moving the head slightly after changing horizontal pitch).

In summary, the basic input to the SET-UP command handler is a character coming from the keyboard. The other input to the SET-UP handler is the current parameter from the RAM. The SET-UP handler output is the new value of the operating parameter. It also outputs new data to the numeric display.

#### **4.8.3 SET-UP/Keyboard Handler Relationship**

Part of the work associated with SET-UP commands is performed by the keyboard handler. The process of entering or leaving SET-UP mode is detected by the keyboard handler, which also controls the corresponding LED indicator. While in SET-UP mode, printable characters go to the SET-UP parsing routines, and control characters are routed to the printer. All other action associated with the SET-UP functions is performed by the SET-UP handler with the exception of entering the answerback message, which is performed by the keyboard handler. The SET-UP commands are code sensitive rather than key-position dependent. Consequently, the SET-UP parsing routines also respond to numeric codes from the optional keypad. The following three keys are independent of SET-UP mode: LINE/LOCAL, LOCAL FORM FEED, and LOCAL LINE FEED. The HERE IS key is also controlled by the keyboard handler.

### **4.9 CHARACTER PROCESSING**

#### **4.9.1 Character Reception**

When a character is received and fully assembled by the USART, an interrupt is sent to the microprocessor. This interrupt is serviced by the character reception routine. This routine reads the character from the USART and checks for parity error. If a parity error has been detected by the USART, the character is converted to a SUB character. If the character is neither NUL nor DEL (the all zeros and all ones codes), it is stored in the input buffer in RAM to be processed by either the input buffer scanner or the background executive routine.

#### **4.9.2 Background Executive**

Characters are processed by the background executive routine. The source of characters may be either the input buffer or the local character slot, which may contain characters generated by the keyboard either in local or SET-UP mode, or if local echo is enabled. The LOCAL FORM FEED and LOCAL LINE FEED keys also use the local character slot, even when on-line.

When the background executive has a character to process, depending on the mode and state of the terminal, it forwards it to one of the following processes:

1. Print Line Builder
2. Escape Sequence Parser
3. SET-UP Command Handler
4. Answerback Entry Handler

Processing of escape sequences and SET-UP commands has been covered in detail earlier in this chapter. Building print lines and processing answerback entry is covered in the following paragraphs.

### 4.9.3 Print Line Builder

Printable characters are routed to the print line builder. Upon receiving a character, the first task performed by the print line builder is to determine if it is a control character or a graphic character. If the character is a control character, it is used to index a table of control routine addresses and an appropriate control routine is executed. For example, routines are required for handling horizontal and vertical tabs. They call other subroutines, which search a tab bit map table to find the first tab set past the current printing position. Each routine returns with a value that specifies what the active line or column should be when the routine has finished. If the character is a graphic character, it is moved into one of two print line buffers, after a certain amount of processing.

The processing of a graphic character requires look-up tables to convert certain codes in the various national languages to an internal code that will point to dot matrix representation of the character. Also, if the printer is in the alternate character set, the character is converted so that it points into the alternate character set dot table.

The print line buffer is then checked to ensure that the active column (the column in which the character is supposed to be deposited) is within the left and right margins. If it is outside these margins and auto newline is enabled, the character is not deposited in the current print line. The current print line is forced to be printed followed by a line feed. The active column is returned to the left margin. The result is as though a carriage return and line feed sequence was received just before the character. The character is then put into the next print line buffer at the left margin. If the character is outside the margin and the auto newline is disabled, the presence of the character means that printing is being attempted beyond the right margin. The character is discarded and a low frequency bell is sounded.

Before attempting to deposit a character in the print line buffer, a test is made to be sure that a character is not already in the buffer at the active column. If there is, an overprint condition exists. Detection of an overprint prevents adding any more characters to the print line buffer until it has been emptied (printed). A new 217-byte print line buffer is made available and the character is written into the new buffer at the active column.

Depositing a character in a print line buffer causes the active column to be incremented by one. Tests are performed to determine if the right margin warning bell should be sounded and to see if the right margin has been reached. Other types of information stored in the print line buffers have to do with producing vertical motion between lines and ringing the bell. Thus, a complete print line contains three types of information: bell count, line feed step count, and character codes. The character codes are positioned in the print line buffer at the same spot that they would appear on the paper. When a print line buffer is full or its printing is forced (due to overprinting, etc.), then the print line buffer is given up by the print line builder and traded for an empty print line buffer. When the full print line buffer is acted on by the printing routines, it has to be prepared before it can be used to start printing characters.

When a line is to be printed, a decision has to be made as to which direction the line is to be printed. A line is always printed forward unless it has vertical motion both before and after it. Also, a line is never printed in reverse which contains overprinting (i.e., a / and an 0 to make  $\emptyset$ ). Recall that a print line buffer is forced to print when overprinting occurs. When forced to print, the buffer is swapped with the empty buffer and the printing routines take over. Since the forced-to-print buffer is not full, it does not have a vertical motion code at the end of the buffer. It has been sent to the printer because of overprinting, not because there is a terminating line feed character at the end of the line. Consequently, the direction decision algorithm would find that this print line buffer did not have vertical motion both before and after it.

If the print line buffer is a complete line bracketed by vertical motion on both sides, then the print direction is decided by the direction algorithm. The algorithm remembers the last column printed on the previous line. If the previous line had characters from columns 1 to 100 and was printed from left to right, then the last column was 100. If the next line has columns from 25 to 125, the direction algorithm finds which of the limits is closest to the last column of the previous line. In this example, 100 is closer to 125 than 25; therefore, the new print line is printed from right to left.

After the print direction has been established, it is necessary to look at the print line buffer in the interval between the left-most and right-most characters to determine if a long sequence of empty positions is in the print line. Otherwise, the interrupt routine would have to search through as many as 215 empty positions to locate the next printable character. To prevent this, the firmware performs a housekeeping routine that scans the print line and converts the empty positions to real spaces (octal code 40) or inserts a special tabbing command. The tabbing commands are interpreted by the printing routine to indicate that there is a long sequence of white space; consequently, stop printing and start slewing the print head. The routine also specifies where to stop slewing and again start printing characters. As an example, suppose a print line has characters from columns 1 to 10, then blanks from columns 10 through 100, and characters again from columns 100 to 110. The housekeeping routine would search the columns until it got to the blank in column 11. It would then start to count blanks. If it finds five empty positions in a row, the routine leaves the printing mode and executes a high speed slew to the next column in which characters will be found. When it finds the next character (in column 100), it will go back to column 11 and write a -1 value in that slot. This flags the column as the beginning of a high speed slew. During printing, when the print routine encounters the -1, it causes the print routine to stop and pass control to a high speed slew routine. The next column (12) contains the address of the column (100) in which is located the next printable character. Thus, the "look-ahead" housekeeping routine functions to speed up the rate of printing.

When the print line buffer is completely filled and the printing interrupt routine is free, the filled print line buffer is passed over to the background printing routine. If there are any bells specified in the print line, the code is passed over to the bell handler routine, which will sound the bell at a 400 or 2400 Hz rate at the proper time. If there are any line feed steps to be performed, the line feed routine will be called, at the appropriate time, to index the stepper motor. Any characters contained within the print line will call the printing routines, which will be scheduled at the appropriate column, and printing will occur. When the print line buffer has been completely processed by the printing routines, an executive routine pointer will exchange the empty print line buffer for the buffer just filled. The empty buffer will be zeroed and returned to the background where it will start accepting new characters.

#### **4.9.4 Answerback Entry Handler**

When the LA120 is in SET-UP mode and CTRL-HERE IS has been typed, a flag is set that causes the background executive to pass all characters to the answerback entry handler. This routine builds a string of characters in RAM to be used as the answerback message. The characters are echoed to the printer by calling the print line builder. Control characters are echoed as "^" followed by the corresponding character from one of the uppercase alphabetic columns of ASCII, which has a code value 64 greater than the control character being entered in the string.

If more than 30 characters is entered, or SET-UP mode is exited during answerback entry, the string of characters is not stored in the non-volatile memory, although it does function as the answerback string until power is cycled or answerback entry is performed again.

If CTRL-HERE IS is typed while performing answerback entry, the answerback message is stored in the non-volatile memory and subsequent characters are treated as SET-UP commands until SET-UP mode is exited.

## **CHAPTER 5**

### **TROUBLESHOOTING THE LA120**

#### **5.1 GENERAL**

Table 5-1 lists the most common LA120 failures, the associated symptoms, and remedies. Check for symptoms in the order given in Table 5-1. Refer to Figure 5-1 for location of logic/power board jacks and cables. Table 5-2 lists the dc voltages and test points on the logic/power board.

When troubleshooting, ensure that all plug-in chips on the logic/power board are seated properly. Improper initialization will probably result if any of these chips have worked loose in their sockets.

Keep in mind that whenever power is interrupted to the LA120, the terminal parameters are reinitialized to their stored values when power is applied.

In troubleshooting the LA120, use the applicable engineering logic drawings from the engineering drawing set. Also contained in the drawing set are unit assembly (UA) drawings that can be used for component location on the logic/power board and the keyboard assembly. The LA120 IPB (EK-LA120-IP) can also be helpful.

#### **WARNING**

**Use extreme care when checking internal portions of the power supply due to exposed 120 Vac.**

#### **CAUTION**

**STATIC CAN DAMAGE COMPONENTS.**

**Logic modules contain static sensitive components. Before handling any subassembly with logic components (removing or installing from LA120 terminal, removing from shipping package, bench handling), touch the LA120 metal frame or some relatively large metal object, to remove static body charges.**



**Table 5-1 LA120 Troubleshooting Procedure**

<b>Symptom</b>	<b>Probable Cause</b>	<b>Remedy</b>
1. No power when POWER switch is set to ON. Fan not operating and no lights.	Main power fuse (F1)  Not plugged in, no power at wall socket  Wiring between ac plug transformer and fan	Check and replace fuse.  Check power cord, wall socket.  Check and replace wiring.
2. Head slams into right bumper and no bell sounds.*	Power supply fuse F3  Power supply  CVT power supply module  Logic/power board	Check and replace fuse F3.  Replace power supply per Paragraph 6.21.  Replace CVT power supply module per Paragraph 6.23.  Replace logic/power board per Paragraph 6.26.
3. Head slams into left bumper and no bell sounds.*	Power supply  CVT power supply module  Cable between J2 on power supply and J2 on logic/power board  Logic/power board	Replace power supply per Paragraph 6.21.  Replace CVT power supply module per Paragraph 6.23.  Reconnect or replace cable.  Replace logic/power board per Paragraph 6.26.
4. Head slams into left or right bumper and bell sounds.*	DC motor/encoder cable to J5 on logic/power board  DC motor/encoder or logic/power board	Reconnect or repair cable.  Perform dc servo test (Paragraph 5.2).
5. Head slams into left or right bumper after LA120 has warmed up.*	Encoder	Perform encoder duty cycle check/adjustment (Paragraph 5.3).

\*Head slamming into bumper may cause CARRIAGE fuse (on logic/power board) to blow after a few seconds.

**Table 5-1 LA120 Troubleshooting Procedure (Cont)**

Symptom	Probable Cause	Remedy
6. No response when power switch is set to ON. Fan is operating but no lights.	<p>5 A pico fuse F1 (located on CVT power supply module)</p> <p>CVT power supply module</p> <p>Cable between J1 on keyboard and J1 on logic/power board</p> <p>Mate-N-Lok P5/J5 between power supply and ac input</p> <p>Power supply</p>	<p>Remove power supply per Paragraph 6.21 and replace pico fuse F1.</p> <p>Replace CVT power supply module per Paragraph 6.23.</p> <p>Reconnect or replace cable.</p> <p>Reconnect or replace wiring.</p> <p>Replace power supply per Paragraph 6.21.</p>
7. Display indicates 8888, print head does not move, and all lights light.	<p>No paper</p> <p>Top cover open</p> <p>Paper-out switch</p> <p>J3 on keyboard</p> <p>Cable between J2 on keyboard and J1 on logic/power board</p> <p>Logic/power board</p>	<p>Replace paper.</p> <p>Close cover.</p> <p>Adjust or replace paper out switch per Paragraph 7.4</p> <p>Reconnect J3. Check cable.</p> <p>Reconnect or replace cable.</p> <p>Replace logic/power board per Paragraph 6.26.</p>
8. Display indicates one blinking digit (0 through 9). Print head does not move.	<p>Logic/power board</p> <p>Flashing 9 could indicate J2 on logic/power board or power supply is disconnected</p>	<p>Turn LA120 off, then back on. If display continues blinking replace logic/power board per Paragraph 6.26.</p> <p>Reconnect J2.</p>

**Table 5-1 LA120 Troubleshooting Procedure (Cont)**

<b>Symptom</b>	<b>Probable Cause</b>	<b>Remedy</b>
9. Print head does not move, some lights light, display does not indicate any number. Bell sounds momentarily on power-up and PAPER OUT light blinks.	Carriage fuse F2 on logic/power board	Replace fuse.
	F2 on power supply	Replace fuse.
	DC motor/encoder or logic/power board	Perform dc servo test (Paragraph 5.2).
	Logic/power board	Perform clock test (Paragraph 5.4).
	Power supply	Replace power supply per Paragraph 6.21.
	Cable to J5 on logic/power board	Reconnect or repair cable.
10. Print head will not initialize properly. Light display is erratic.	Power supply or logic and power board.	Perform wake up test (Paragraph 5.5).
11. Print head moves left then right a few spaces; however, display indicates a number other than 1 (number does not flash).	Logic/power board	Replace logic/power board per Paragraph 6.26.
	Keyboard	Replace keyboard per Paragraph 6.20.
	Cable between J2 on keyboard and J1 on logic/power board.	Replace cable.
12. Display does not appear to work or lights appear to be faulty.	Display or lights	To check display and lights turn power OFF, open top cover, then turn power ON. Display should indicate 8888 and all lights should light. If display is bad, replace keyboard per Paragraph 6.20. Replace lights as required.

**NOTE**

**The following steps exercise the logic/power board and the printing mechanism.**

13. Press CTRL and SET-UP to enter SET-UP. SET-UP light does not blink.	Logic/power board or keyboard	While in LOCAL, press additional keyboard keys to isolate fault between keyboard and logic/power board. Replace logic/power board or keyboard per Paragraphs 6.26 or 6.20.
---	-------------------------------	--



**Table 5-1 LA120 Troubleshooting Procedure (Cont)**

<b>Symptom</b>	<b>Probable Cause</b>	<b>Remedy</b>
14. While in SET-UP, press T to start self-test. Print head does not fire in self-test mode; however, carriage moves across carriage bar.	Print head Print head cable disconnected Logic/power board	Replace print head per Paragraph 6.3. Reconnect print head cable. Replace logic/power board per Paragraph 6.26.
15. No printout in self test; however, carriage moves across carriage bar and head solenoids sound as if they are firing.	Carriage adjustment lever Ribbon Ribbon chassis assembly	Adjust print head using carriage adjustment lever. Check and replace ribbon. Check to see if ribbon moves freely; if required, replace ribbon chassis assembly per Paragraph 6.18.
16. Missing dots or excessive dots in characters.	Print head, print head cable, or logic/power board	Perform print character test (Paragraph 5.6).
17. Missing or incorrect characters (always the same character).	USART or ROM chip Keyboard	Perform USART Test (Paragraph 5.7). Perform keyboard test (Paragraph 5.8).
18. No line feed response from one of the following keys. Other two keys function normally. • LINE FEED • LOCAL LINE FEED • LOCAL FORM FEED	Keyboard	Perform keyboard test (Paragraph 5.8).
19. No line feed response from any of the following keys: • LINE FEED • LOCAL LINE FEED • LOCAL FORM FEED	Logic and power board or stepper motor	Perform line feed test (Paragraph 5.9).
20. Bell does not sound during self-test.	Logic and power board or speaker	Perform bell test (Paragraph 5.10).
21. Bell sounds during self-test but does not sound when CTRL G is pressed.	Keyboard	Perform keyboard test (Paragraph 5.8).

**Table 5-1 LA120 Troubleshooting Procedure (Cont)**

<b>Symptom</b>	<b>Probable Cause</b>	<b>Remedy</b>
22. LA120 operates in self-test; however, printout is incorrect when operating with user's equipment.	User equipment, 20 mA/EIA interface, or logic/power board  USART  Modem  Incorrect SET-UP parameters.	Connect 20 mA or EIA loop back connector to interface cable. Place the LA120 on-line and type a few characters. If LA120 operates correctly, problem is with users equipment. If LA120 does not operate correctly, replace EIA interface cable, or logic/power board per Paragraph 6.26. (If 20 mA option is used, replace 20 mA cable or circuit board.)  Perform USART test (Paragraph 5.7).  Replace modem.  Check SET-UP parameters.
23. Loss of position when printing multiple lines.	Logic/power board  Power supply  Encoder	Replace logic/power board per Paragraph 6.26.  Replace power supply per Paragraph 6.21.  Perform encoder duty cycle check/adjustment (Paragraph 5.3).
24. Print varies in density from dark to light or light to dark across page.	Print bar out of alignment	Perform print bar adjustment per Paragraph 7.9.
25. Print density varies randomly across page.	Ribbon  Power board	Replace ribbon.  Replace logic/power board per Paragraph 6.26.
26. Printing is always light in the same spot.	Print bar pitted or bent printer mechanism	Replace print bar per Paragraph 6.6 or printer mechanism per Paragraph 6.22.
27. Printing density progressively drops off to no impression when printing single or multiple lines.	Ribbon drive assembly does not move ribbon  Print head screws that secure head to carriage have worked loose.	Replace ribbon drive assembly per Paragraph 6.11.  Adjust print head per Paragraph 7.1

**Table 5-1 LA120 Troubleshooting Procedure (Cont)**

Symptom	Probable Cause	Remedy
28. Ribbon does not reverse.	Ribbon or ribbon chassis assembly	Check for eyelet on ribbon. Replace ribbon or ribbon chassis assembly.
	Pushrod disengaged	Reconnect pushrod.
29. Paper jams.	Paper path obstruction	Clear paper path.
	Carriage adjustment lever	Adjust carriage adjustment lever.
	Tractors	Replace tractors per Paragraph 6.15.
	Head gap	Check and adjust head gap per Paragraph 7.1

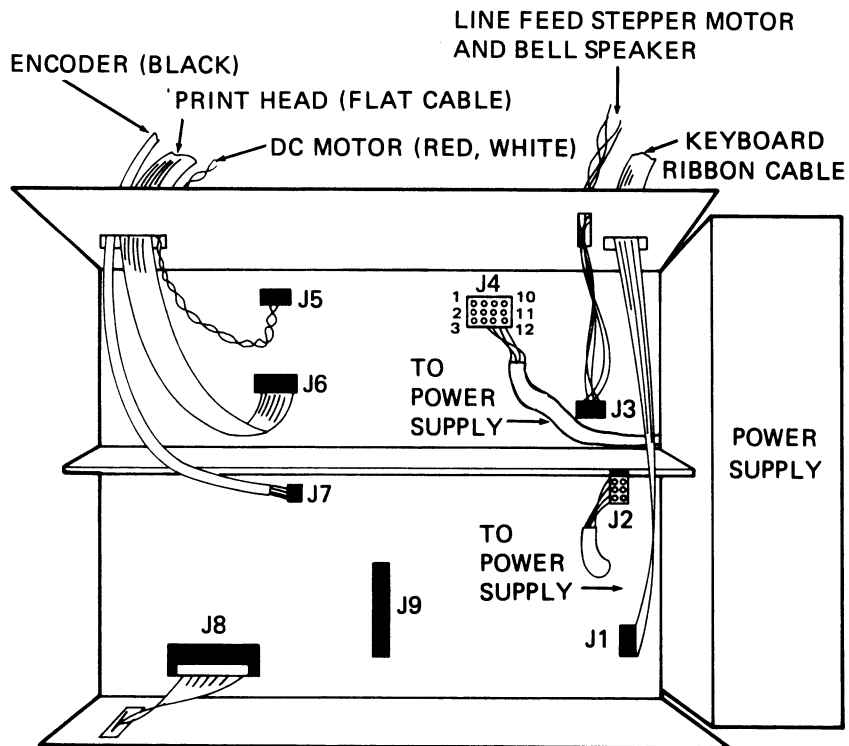

MA-2565A

**Figure 5-1 Logic/Power Board Connectors**

**Table 5-2 DC Supply Voltages**

<b>Voltage (V)</b>	<b>Tolerance (V)</b>	<b>Logic/Power Board Test Points (Figure 5-1)</b>
+5	±0.25	J2-6
+12	±0.6	J2-2
-12	±0.6	J2-3
+24	±2.0	J4-1,2,3
-24	±2.0	J4-7,8,9

**Note:** All voltages measured with respect to ground.

## **5.2 DC SERVO TEST**

1. Disconnect power from terminal.
2. Remove printer housing (Paragraph 6.2.1) and tape down cover interlock. Open rear door.
3. Push carriage assembly to the extreme left and slip timing belt off dc motor pulley.
4. Disconnect P5 from logic and power board. Connect +5 V to dc servo motor via pins 1 and 2 of P5 (filter capacitors C47, C48, C49, – provide a +5 V source). Connect +5 V to pin 1 (white wire) and ground to pin 2 (red wire). Apply power to terminal.
5. Check output of encoder per Paragraph 5.3.
6. Remove power from terminal. Connect channel 1 of scope to pin 8 of E25 (MINUS L) and channel 2 to pin 9 (PLUS L). Set up scope according to Figure 5-2.
7. Apply power to terminal. Check that dc motor is turning in a counterclockwise direction as viewed from the front of the terminal. (If the timing belt were on, the print head would be driven to the left.) Check for the waveform shown in Figure 5-2a. With a dc voltmeter, check servo amplifier output on pin 2 (red wire) of J5. The reading should be about +23 V.
8. Reverse +5 V connection to P5 by connecting ground to pin 1 (white wire) and +5 V to pin 2 (red wire). The dc motor will turn in a clockwise direction. Change scope trigger source from CHAN2 to CHAN1 and check for the waveshape of Figure 5-2b. Check servo amplifier dc output on pin 2 (red wire) of J5. The dc voltmeter should read about –23 V. Remove power and reconnect J/P5.
9. Remove scope leads. Slip timing belt onto dc motor pulley. Close up lower rear panel and install printer housing (Paragraph 6.2.2).

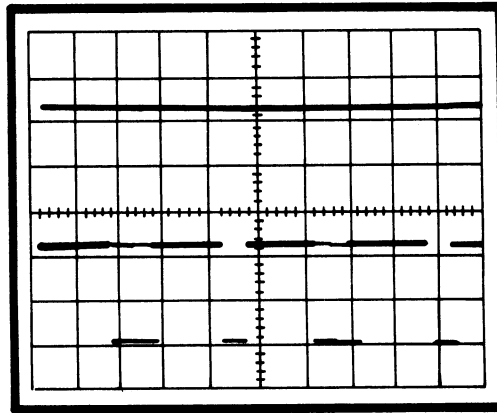

a. Motor Being Driven Counterclockwise

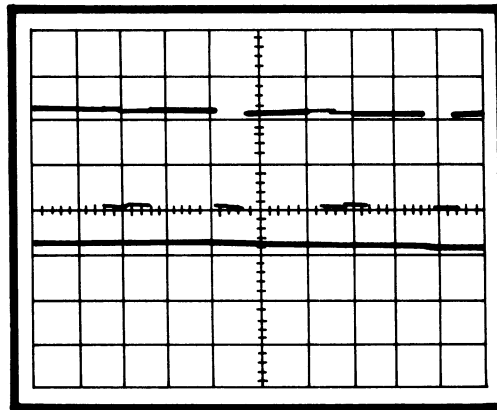

b. Motor Being Driven Clockwise

SCOPE SETUP

VOLTS/DIV: 5V CHANNELS 1 AND 2  
 VERTICAL MODE: CHOP  
 SWEEP SPEED: 0.1 MS/DIV  
 TRIG MODE: NORMAL  
 TRIG SOURCE: CHAN 2, DC, INT, POS  
 FOR FIGURE 5-2A. CHANGE  
 TO CHAN 1 FOR FIGURE 5-2B.

MA-4679

Figure 5-2 DC Servo Signals

**5.3 ENCODER DUTY CYCLE CHECK/ADJUSTMENT**

1. Disconnect power from terminal.
2. Remove printer housing (Paragraph 6.2.1) and tape down cover interlock. Open rear door.

3. Push carriage assembly to the extreme left and slip timing belt off dc motor pulley.
4. Check channel 1 output of the encoder by connecting channel 1 of the scope to pin 6 of E25 on the logic and power board. Apply power to terminal. The dc motor/encoder will rotate continuously. Adjust scope for settings given in Figure 5-3 and check for waveshape shown. The waveshape must show a 50 percent duty cycle (equal positive and negative alternations) as measured from the center of the waveform jitter.
5. If encoder output is good, proceed to Step 8. If the duty cycle is not 50 percent, proceed to Step 6.
6. Remove the two screws and the circular cover from rear of dc motor/encoder. If motor/encoder is the Hitachi model, the rear cover is square and is popped off instead of unscrewed.

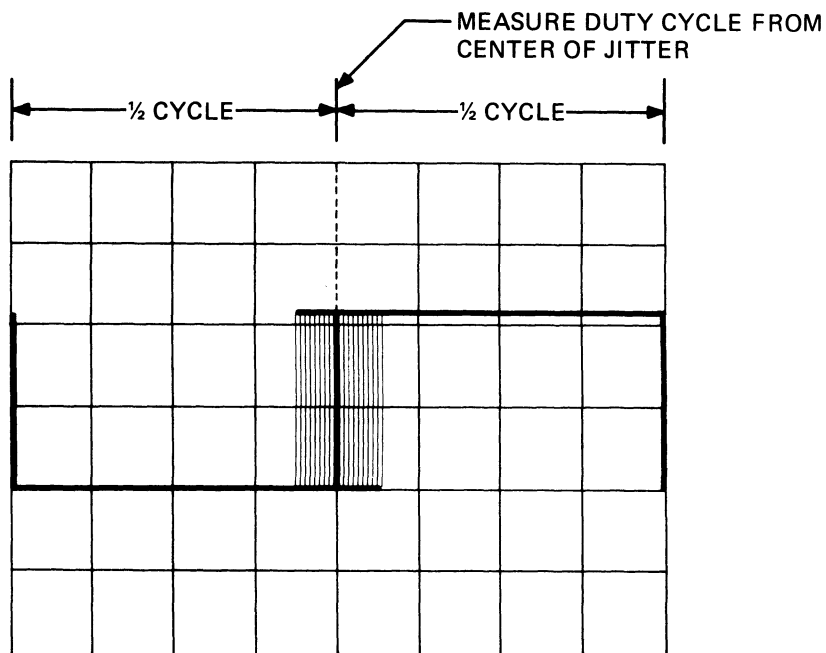

**SCOPE SETUP**

VOLTS/DIV:        2V

VERTICAL MODE:   CHAN 1

SWEEP SPEED:     20  $\mu$ S/DIV; ADJUST VARIABLE  
SWEEP SPEED FOR ONE CYCLE  
FILLING ENTIRE SWEEP

TRIG MODE:        NORMAL

TRIG SOURCE:      CHAN 1, DC, INT, POS

MA-4684

Figure 5-3 Encoder Output Waveform

7. Adjust channel 1 adjustment (Figure 5-4) for a 50 percent duty cycle. Apply glyptol to the potentiometer after adjusting.
8. Connect channel 1 of scope to pin 7 of E25 to check channel 2 output of the encoder. Check for waveshape shown in Figure 5-3. The waveshape must show a 50 percent duty cycle as measured from the center of the waveform jitter.
9. If duty cycle is not 50 percent, perform Steps 6 and 7 for channel 2 adjustment.
10. With belt tension spring in place (Figures 6-5 and 6-6), press left-hand pulley against printer mechanism and slip timing belt onto dc motor pulley.
11. Install printer housing (Paragraph 6.2.2).

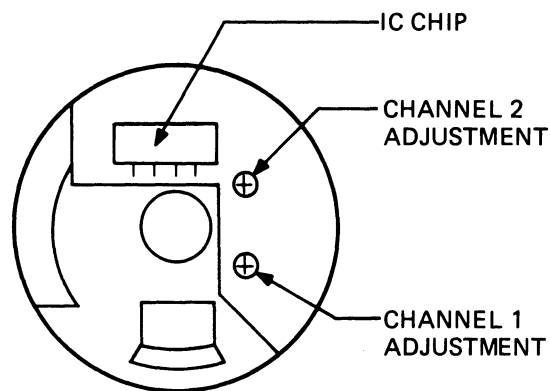

a. Litton, Clifton Precision Model

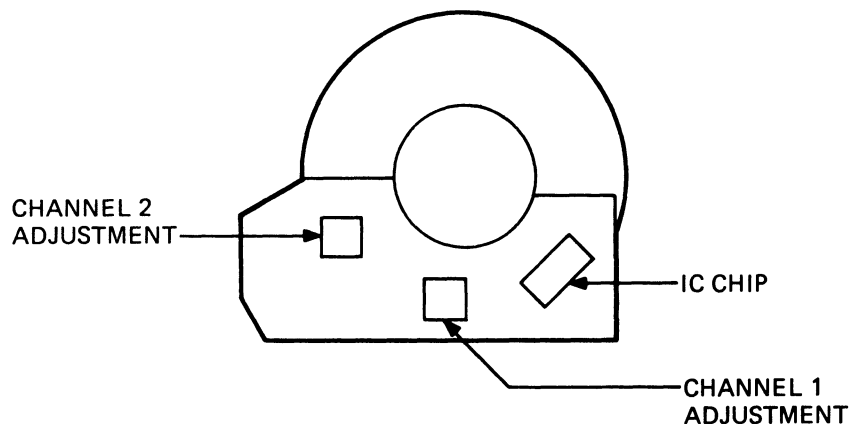

b. Hitachi Model

MA-4702

**NOTE:**

THE ENCODER CIRCUIT BOARD MAY BE ORIENTATED IN ANY POSITION AROUND A 360° CIRCUMFERENCE, NOT NECESSARILY AS SHOWN ABOVE. THE CHANNEL 2 ADJUSTMENT IS CLOSEST TO THE IC CHIP ON THE CLIFTON PRECISION MODEL AND FARTHEST FROM THE CHIP ON THE HITACHI MODEL.

Figure 5-4 Encoder Circuit Board

## 5.4 CLOCK TEST

The clock test checks the operation of the 18 MHz crystal and the 8224 clock chip E23.

1. Check  $\phi 1$  and  $\phi 2$  clock signals from E23 by connecting channel 1 of scope to pin 11 of E23 and channel 2 of scope to pin 10. Setup scope according to Figure 5-5 and check for wave-shape shown.
2. Check that 8080A microprocessor is being clocked through its addressing sequence by connecting channel 1 of the scope to any of the sixteen output address lines. The address lines out of the 8080A (E22) are designated A0 through A15. Set up scope according to Figure 5-6 and check for waveshape shown. The waveshape will be unsteady due to address sequencing of the 8080A.
3. Disconnect scope leads and close lower rear panel on terminal.

## 5.5 WAKE UP TEST

1. Remove power from terminal. Open lower rear panel.
2. Connect channel 1 of scope to DC OK L at the junction of C52/C53 and R4 (bottom of R4 is most accessible). Connect channel 2 of scope to DC OK H at E23-2. Set up scope according to Figure 5-7.

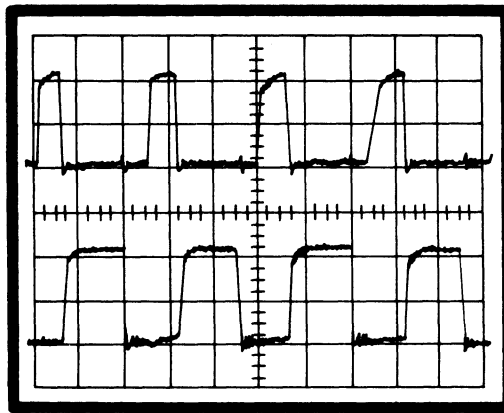

### SCOPE SETUP

VOLTS/DIV: CHANNELS 1 AND 2 = 5V  
VERTICAL MODE: ALTERNATE  
SWEEP SPEED: 0.2  $\mu$ S/DIV  
TRIG MODE: NORM  
TRIG SOURCE: CHI, DC, INT, POS

MA-4687

Figure 5-5  $\phi 1$  and  $\phi 2$  Clock Signals



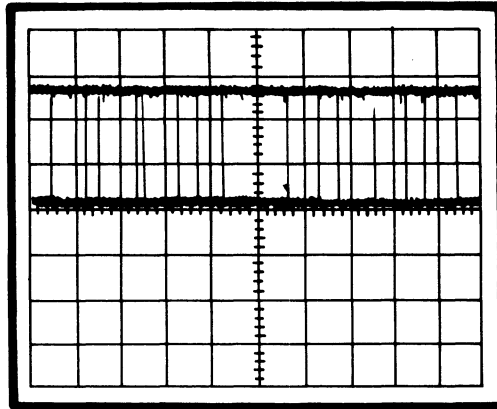

SCOPE SETUP

VOLTS/DIV: 2V  
 VERTICAL MODE: DC  
 SWEEP SPEED: 10  $\mu$ s/DIV  
 TRIG MODE: NORM  
 TRIG SOURCE: CHI, POS, INT\*

\* USE AC HIGH FREQUENCY REJECT.

MA-4676

Figure 5-6 8080A Addressing Output

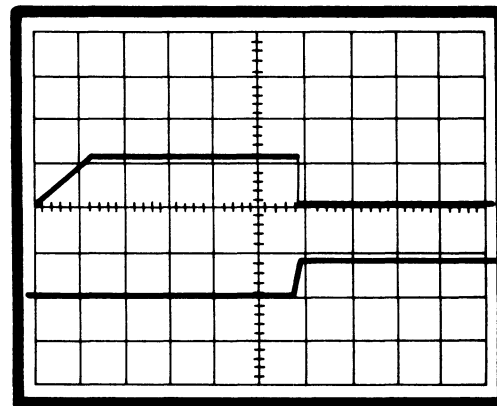

SCOPE SETUP

VOLTS/DIV: 5V  
 VERTICAL MODE: SINGLE TRACE  
 SWEEP SPEED: 0.1 SEC/DIV  
 TRIG MODE: NORMAL  
 TRIG SOURCE: CHAN 1, DC, INT, POS

MA-4686

Figure 5-7 DC Wake Up Waveform

3. Apply power to terminal and check for waveshape of Figure 5-7. The DC OK L ramp should be approximately 0.6 seconds. Turn power off and on to repeat the waveshape.

**NOTE**

**Leave power off for about 10 seconds to allow for capacitor discharge. Otherwise, the DC OK L ramp will not occur when power is applied.**

4. Remove power from terminal. Check RESET H by changing channel 1 of the scope to E23-1. Leave channel 2 input and set up as in Step 3. Apply power and check for the waveshape of Figure 5-7.
5. Remove power from terminal. Disconnect scope leads and close lower rear panel.

### **5.6 PRINT CHARACTER TEST**

The print character test checks print head operation and the circuits that process the character signal prior to application to the print head. The slash character (/) is used for most of the waveforms shown in this test. The slash is an ideal test character because it fires all seven wires in the print head and fires them only once. Other characters would produce different waveforms according to which wires are fired and how many times they are fired (see note in Step 4).

Sheet 5 of engineering drawing M7081 contains the print head schematic. In the upper right-hand corner of the sheet is a 7-dot printed image showing the signal versus dot position relationship for the seven print head wires. Use this image to determine which signal channel(s) are causing the faulty print character. Examine the character to determine which dots are missing or which dots are firing too often. Note on the logic print that each VDR head enable signal controls one-half of the print head, while each DR drive signal controls only one channel.

1. Remove power from terminal.
2. Using an ohmmeter, check continuity of print head solenoid in faulty channel. Check from pin 3 (metal screw) of drive switch transistor (Q16, Q19, Q32, Q33, Q34, Q35 or Q36, depending on which channel is faulty) to pin 3 of head enable switch transistor (Q30 or Q31).

(This checks connector J/P6 and cabling along with print head solenoid.) The resistance of a print head solenoid is about 2.5 ohms.

3. Connect channel 1 of scope to output of the faulty channel of E25. Set up scope according to Figure 5-8.
4. Apply power to terminal. Place terminal in local mode. Press and hold down the “/” key and check for the waveform of Figure 5-8a.

**NOTE**

**Due to the slash (/) character firing each wire once, the waveshape of Figure 5-8a will be obtained for any of the seven solenoid (S) signals from E25. If signal S1 (top of printed image) is viewed (E25-21) and uppercase “T” is pressed, the top wire will fire four times producing the waveform of Figure 5-8b.**

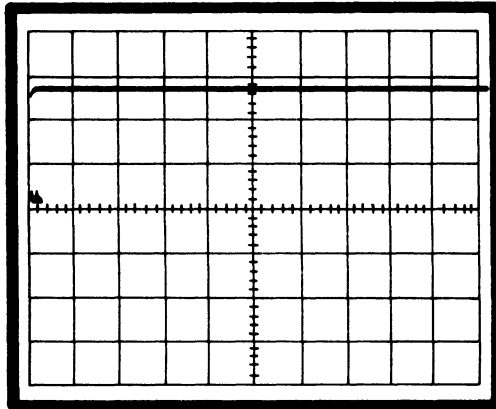

a. The Character “/”

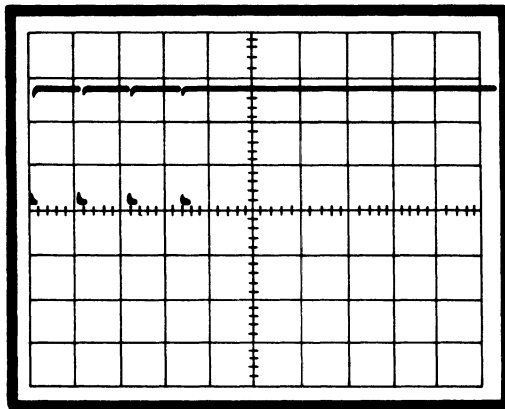

b. The Character “T”

SCOPE SETUP

VOLTS/DIV: 2V  
 VERTICAL MODE: CHAN 1  
 SWEEP SPEED: 5 MS/DIV  
 TRIG MODE: NORMAL  
 TRIG SOURCE: CH1, DC, INT, NEG

MA-4689

Figure 5-8 Solenoid Signal Output of DC305

5. Connect channel 1 of scope to drive signal output of the driver for the solenoid signal being checked (DR output of E40 or E45). Connect channel 2 of scope to current feedback pin (FB) of same driver. Use ac coupling for channel 2 input to scope. Set up scope according to Figure 5-9.
6. Press and hold the “/” key and check for the waveform of Figure 5-9a. If print head solenoid is open, there will be no current feedback to driver (channel 2 on scope) and driver output will be as shown in Figure 5-9b.

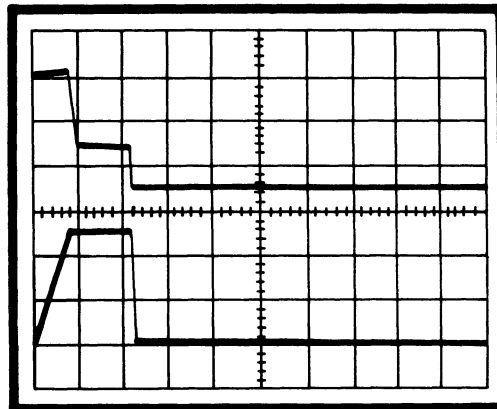

a. Normal Waveform

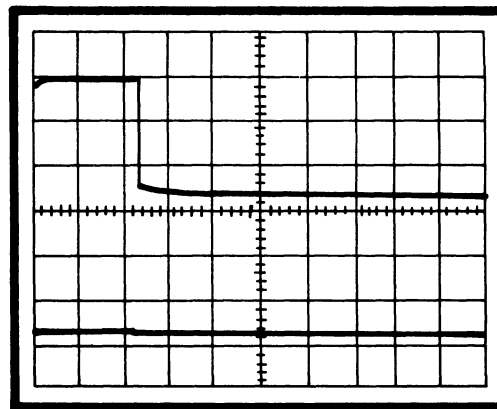

b. Open Print Wire

SCOPE SETUP

VOLTS/DIV: CH1 = 10V;CH2 = 2V\*  
 VERTICAL MODE: CHOP  
 SWEEP SPEED: 0.2 MS/DIV  
 TRIG MODE: NORMAL  
 TRIG SOURCE: CH1, DC,INT,POS

\*USE AC COUPLING FOR CHANNEL 2 TO FLOAT SIGNAL

MA-4674

Figure 5-9 Drive Signal to Print Solenoid

7. Connect channel 1 of scope to head enable output of signal driver chip for solenoid signal being checked [pin 9 (VDR) of E40 or E45]. Connect channel 2 of scope to drive signal output pin (DR) of signal driver being checked. Set up scope according to Figure 5-10.
8. Press and hold the “/” key and check for the waveform of Figure 5-10.
9. Disconnect scope leads. Close lower rear panel.

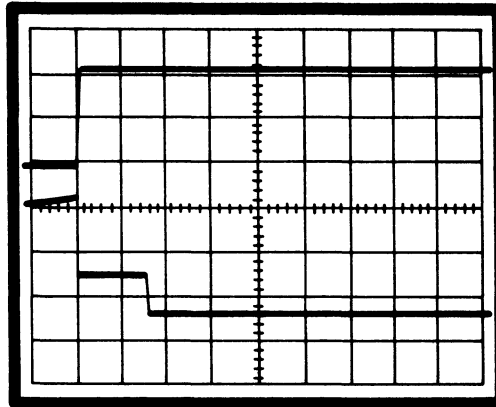

**SCOPE SETUP**

VOLTS/DIV: CH1 = 20V; CH2 = 10V  
 VERTICAL MODE: CHOP  
 SWEEP SPEED: 0.2 MS/DIV  
 TRIG MODE: CHOP  
 TRIG SOURCE: CH1, DC, INT, POS

MA-4685

Figure 5-10 Head Enable vs Drive Signal

**5.7 USART TEST**

The USART test checks the 8251A USART, the I/O path to the user's equipment (LA120 portion), and the transmit and receive clocks for various baud rates.

1. Remove power from terminal and swing down rear cover panel.
2. Check baud rates by connecting channel 1 of scope to E28-9 (TXC). Set up scope according to Figure 5-11.
3. Apply power to terminal. Place LA120 in SET-UP mode and set in a baud rate of 50. Check for 50 baud waveshape shown in Figure 5-11a.
4. Set in the baud rates shown in Figure 5-11b through 5-11m and check for corresponding waveshapes. Change horizontal sweep speed when indicated in figure.

**NOTE**

**Note that TXC rate changes at 200 baud and at 7200 baud. Multiplier circuits within the USART are enabled at these frequencies to increase TXC to the correct rate.**

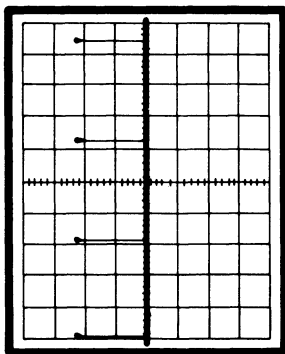

a. 50 Baud, Sweep Speed = 0.1 ms

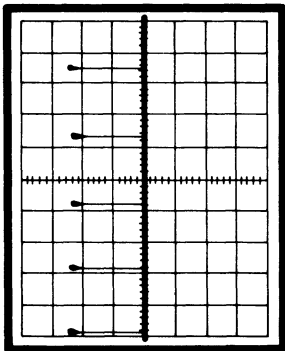

b. 75 Baud, Sweep Speed = 0.1 ms

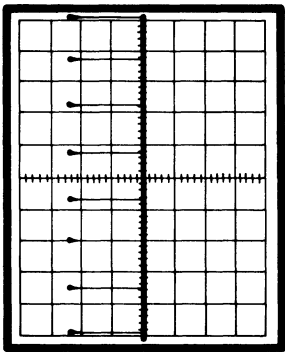

c. 110 Baud, Sweep Speed = 0.1 ms

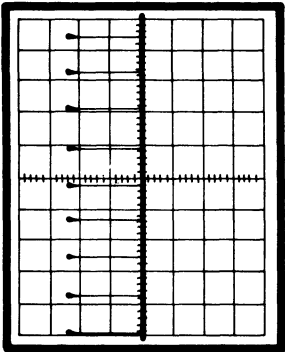

d. 134 Baud, Sweep Speed = 0.1 ms

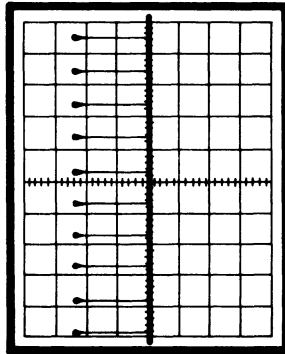

e. 150 Baud, Sweep Speed = 0.1 ms

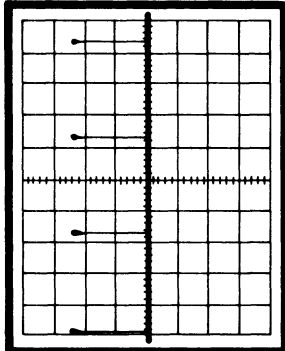

f. 200 Baud, Sweep Speed = 0.1 ms

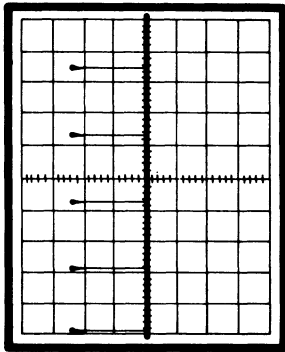

g. 300 Baud, Sweep Speed = 0.1 ms

SCOPE SETUP

VOLTS/DIV: 2V

VERTICAL MODE: CHAN 1

SWEEP SPEED: AS NOTED FOR EACH WAVE FORM.

TRIG MODE: NORM

TRIG SOURCE: CHAN 1, DC, INT, POS

MA-4892

Figure 5-11 LA120 Baud Rate Clocks (Sheet 1 of 2)

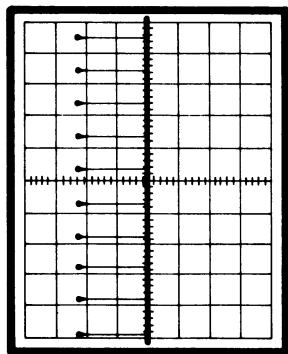

h. 600 Baud, Sweep Speed = 0.1 ms

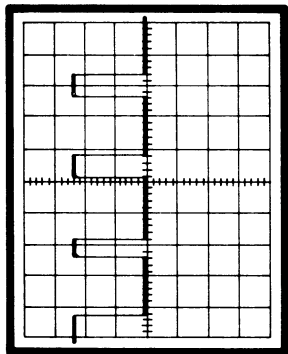

i. 1200 Baud, Sweep Speed = 5  $\mu$ s

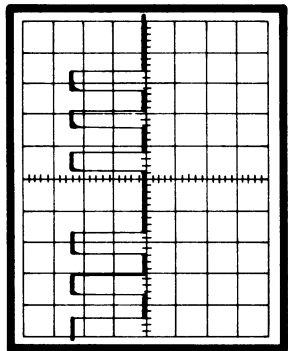

j. 1800 Baud, Sweep Speed = 5  $\mu$ s

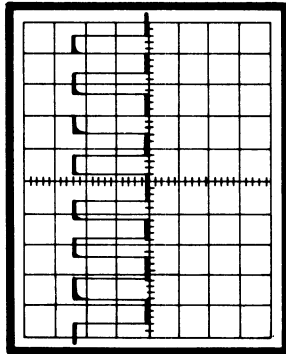

k. 2400 Baud, Sweep Speed = 5  $\mu$ s

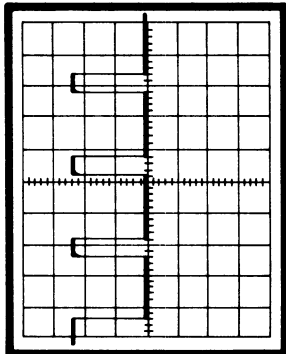

l. 7200 Baud, Sweep Speed = 5  $\mu$ s

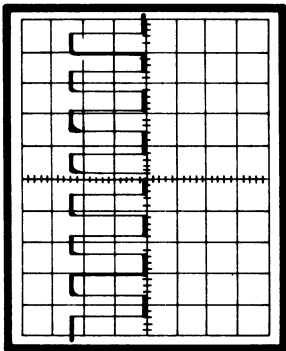

m. 9600 Baud, Sweep Speed = 5  $\mu$ s

SCOPE SETUP

VOLTS/DIV: 2V

VERTICAL MODE: CHAN 1

SWEEP SPEED: AS NOTED FOR EACH WAVE FORM.

TRIG MODE: NORM

TRIG SOURCE: CHAN 1, DC, INT, POS

MA-4693

Figure 5-11 LA120 Baud Rate Clocks (Sheet 2 of 2)

5. Check RXC by connecting channel 1 of scope to E28-25 and repeating Steps 3 and 4. The RXC waveshapes at E28-25 are identical to TXC waveshapes at E28-9.
6. Clocks TXC and RXC are derived from ITC and IRC clocks out of the DC305 (E25-15, -14). The signal waveshapes at these points are identical to those in Figure 5-11.
7. Check USART I/O path as follows. Remove power from LA120. Wrap TXD EIA output around to RXD input by jumpering pins C and E of J8 on logic/power board. Connect channel 1 of scope to TXD output from USART (E28-19). Connect channel 2 of scope to J8 jumper. Set up scope according to Figure 5-12.
8. Apply power and place LA120 in modem setting 1.\* Press and hold “/” key and check for the waveform of Figure 5-12.
9. Connect channel 1 of scope to RXD input to USART (E28-3). Leave channel 2 connected to J8 jumper and do not change scope settings. Waveform should be as shown in Figure 5-12.
10. Remove scope leads and close rear cover panel.

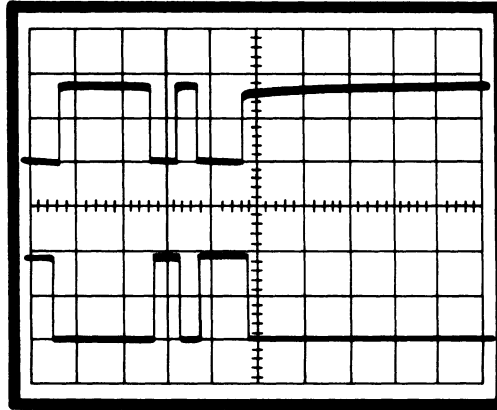

SCOPE SETUP

VOLTS/DIV:	CHANNEL 1 = 2V CHANNEL 2 = 10V
VERTICAL MODE:	CHOP
SWEEP SPEED:	0.2 MS/DIV
TRIG MODE:	NORM
TRIG SOURCE:	CHAN 1, DC, INT, NEG

MA-4688

Figure 5-12 USART I/O Signals

\* LA120 must be in modem setting 1 to remove enabling requirements imposed by EIA interface signals.



## 5.8 KEYBOARD TEST

1. Remove power from terminal. Remove printer housing (Paragraph 6.2.1). Place LA120 in local mode. Proceed directly to Step 6 if faulty key/switch is one of the following:

SET-UP  
RETURN  
CTRL  
CAPS LOCK

SHIFT  
PAPER OUT (Switch)  
COVER INTERLOCK (Switch)

2. Using keyboard schematic, note which scanning chip (E5, E6, E101, E102) is connected to the nonfunctioning key. Turn over the keyboard bezel and connect channel 1 of scope to pin 1 of scanning chip.
3. Apply power. Set up scope according to Figure 5-13. The waveshape seen on scope (Figure 5-13) is due to keyboard scan and does not represent a signal condition. The waveshape will be a steady pattern but may not exactly match that shown in Figure 5-13.\*
4. Press the nonfunctioning key. The waveshape should change to an unsteady† pattern similar to that shown in Figure 5-14.

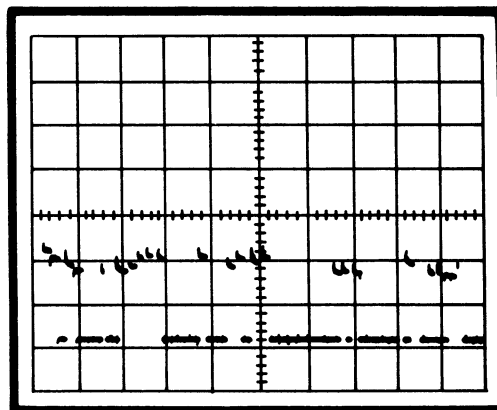

### SCOPE SETUP

VOLTS/DIV:	2V
VERTICAL MODE:	NORMAL
SWEEP SPEED:	10 $\mu$ s/DIV
TRIG MODE:	NORMAL
TRIG SOURCE:	CHAN 1,DC,INT,POS

MA-4675

Figure 5-13 Keyboard Scan Waveform

\* The scope is triggered on a dc level. Pattern depends on which scan pulse triggers scope.

† The changing nature of the pattern is due to microprocessor program action.

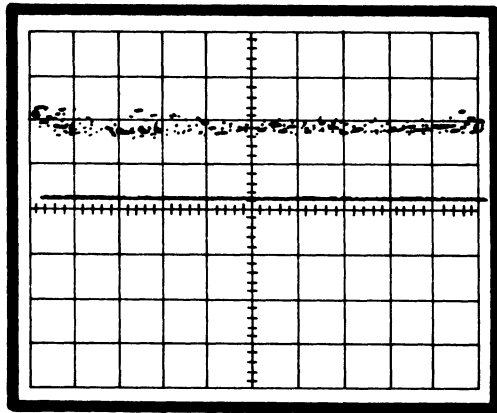

**SCOPE SETUP**

VOLTS/DIV:	2V
VERTICAL MODE:	NORMAL
SWEEP SPEED:	10 $\mu$ s/DIV
TRIG MODE:	NORMAL
TRIG SOURCE:	CHAN 1, DC, INT, POS

MA-4677

Figure 5-14 Keyboard Scan Waveform with Key Pressed

5. Connect channel 1 of scope to pin on scanning chip that connects to nonfunctioning key. Set up scope according to Figure 5-15. Press nonfunctioning key and check for waveform shown. Trace circuit through key and J1, to KBD IN chip (E2) on logic and power board. The waveshape of Figure 5-15 should also appear on the corresponding pin of E2. If proper waveform is not obtained, check key and associated circuitry.
6. Check pin on scanning chip E8 that connects to nonfunctioning key/switch. The pin should go to 0 V (ground) when key/switch is closed.
7. Connect channel 1 of scope to pin 5 (KD7 L) of scanning chip E8. Set up scope according to Figure 5-16. The waveshape seen on the scope (Figure 5-16) is due to keyboard scan and does not represent a signal condition. The waveshape will be a steady pattern but may not exactly match that shown in Figure 5-16.\*
8. Press nonfunctioning key. The waveshape should change to an unsteady pattern similar to that of Figure 5-16. Trace KD7 L through J2 and J1 to KBD IN chip (E2) on logic and power board. The waveshape of Figure 5-16 should also appear on pin 2 of E2.

---

\*The scope is triggered on a dc level. Pattern depends on which scan pulse triggers scope.

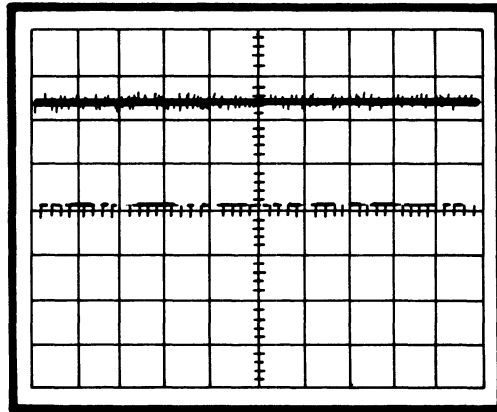

SCOPE SETUP

VOLTS/DIV: 2V  
 VERTICAL MODE: CHAN 1  
 SWEEP SPEED: 10  $\mu$ s/DIV  
 TRIG MODE: AUTO  
 TRIG SOURCE: CHAN 1, DC, INT, POS

MA-4673

Figure 5-15 Key Circuit Waveform

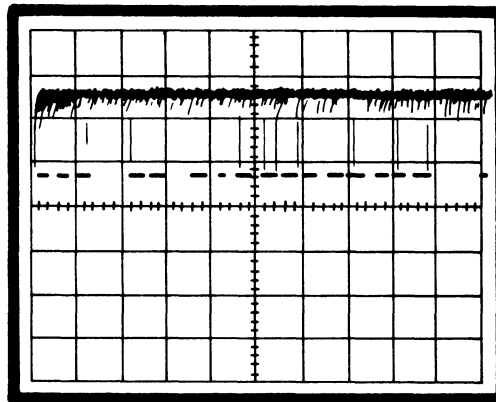

SCOPE SETUP

VOLTS/DIV: 2V  
 VERTICAL MODE: NORMAL  
 SWEEP SPEED: 5  $\mu$  SEC/DIV  
 TRIG MODE: NORMAL  
 TRIG SOURCE: CHAN 1, DC, INT, POS

MA-4691

Figure 5-16 Keyboard Scan for Chip E8

### 5.9 LINE FEED TEST

The line feed test checks the printer LSI and the line feed amplifier (both on the logic/power board) and the stepper motor.

1. Remove power from terminal. Remove paper from terminal.
2. Jam paper into paper-out switch to override interlock.
3. Apply power to terminal.
4. Place terminal in local mode with LINE LOCAL key.
5. Connect channel 1 of scope to pin 13 of E25 on logic and power board. Connect channel 2 of scope to pin 12. Set up scope according to Figure 5-17. Press LINE FEED and observe the two channel inputs to the line feed amplifiers. Check that the waveforms are as shown in Figure 5-17.

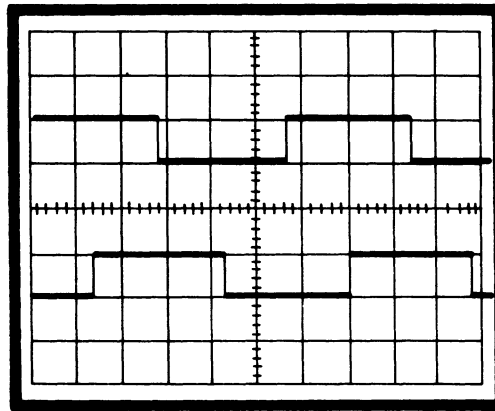

#### SCOPE SETUP

VOLTS/DIV:	5V, CHANNELS 1 AND 2
VERTICAL MODE:	CHOP
SWEEP SPEED:	2 MS/DIV
TRIG MODE:	NORMAL
TRIG SOURCE:	CHAN 1, DC, INT, POS

MA-4690

Figure 5-17 Line Feed Signal Output of DC305

6. Each phase of the quadrature phase, push-pull, line feed amplifier is checked by connecting channel 1 of scope to amplifier channel input and channel 2 to amplifier output. Set up scope according to Figure 5-18. Connect scope inputs according to Table 5-3. Press LOCAL FORM FEED and check for waveform specified in table.
7. Check run signal of line feed amplifier by connecting channel 1 of scope to E14-9 (amplifier input) and channel 2 to pin 3 (collector) of Q11 (amplifier output). Set up scope according to Figure 5-19. Press LINE FEED and check for waveshape shown.

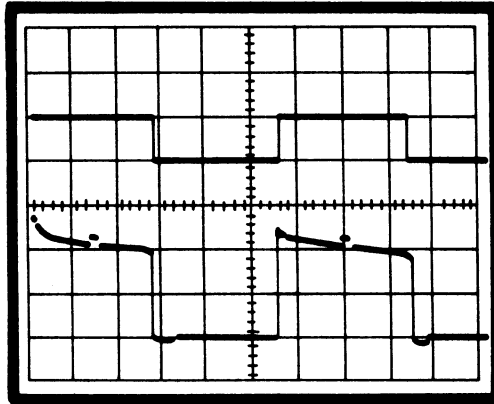

a. Phase 1 and 2

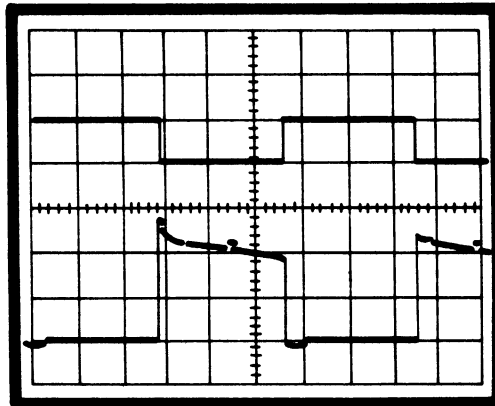

b. Phase 3 and 4

**SCOPE SETUP**

VOLTS/DIV: 5V/DIV, CHANNEL 1  
20V/DIV, CHANNEL 2

VERTICAL MODE: CHOP

SWEEP SPEED: 2 MS/DIV

TRIG MODE: NORMAL

TRIG SOURCE: CHAN 1, DC, INT, POS

MA-4682

Figure 5-18 Line Feed Amplifier Input vs Output

**Table 5-3 Line Feed Amplifier Test**

Amplifier Phase Under Test	Scope Channel 1	Scope Channel 2	Waveform Figure No.
Phase 1	E3-1	Q15-3*	5-18a
Phase 2	E3-5	Q13-3*	5-18a
Phase 3	E14-13	Q14-3*	5-18b
Phase 4	E14-11	Q12-3*	5-18b

\*Pin 3 is the collector.

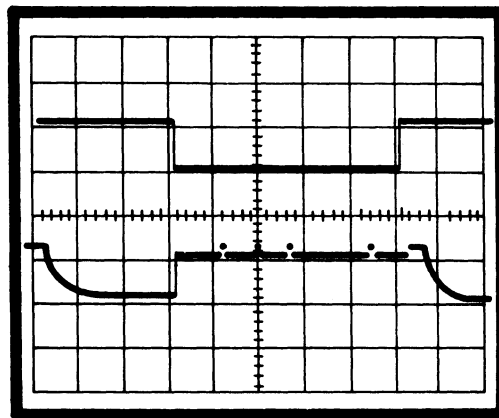

**SCOPE SETUP**

VOLTS/DIV: 5V/DIV, CHANNEL 1  
20V/DIV, CHANNEL 2

VERTICAL MODE: CHOP

SWEEP SPEED: 5 MS/DIV

TRIG MODE: NORMAL

TRIG SOURCE: CHAN 1, DC, INT, POS

MA-4680

**Figure 5-19 Line Feed Run Signal**

- Remove power from terminal. Disconnect P7 to check stepper motor windings. Using an ohmmeter, check between the following pins on P3:

- 1 and 2
- 2 and 3
- 6 and 7
- 7 and 8.

All four readings should be  $7.5 \pm 0.5$  ohm.

- Remove scope leads and close lower rear cover.

## 5.10 BELL TEST

1. Apply power to terminal and initialize to the SET-UP parameters.
2. Place terminal in local mode with LINE LOCAL key. Open rear door.
3. Check input to bell amplifier by connecting channel 1 of scope to pin 10 of E25 on logic and power board. Set up scope according to Figure 5-20. Press CTRL G and check for the waveshape of Figure 5-20a. A high volume bell should sound. Check low volume bell signal by pressing SET-UP G and then CTRL G. The low volume bell will sound and the waveshape of Figure 5-20b should appear on scope. Press SET-UP G to return to high volume bell signal.

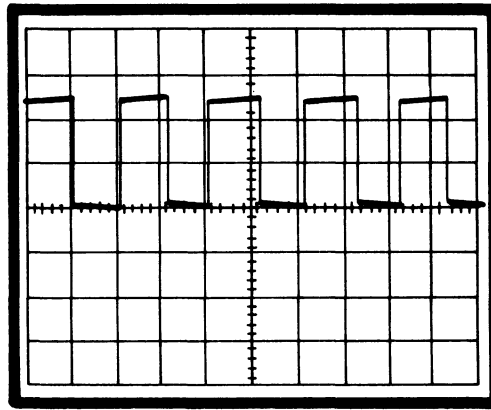

a. High Volume

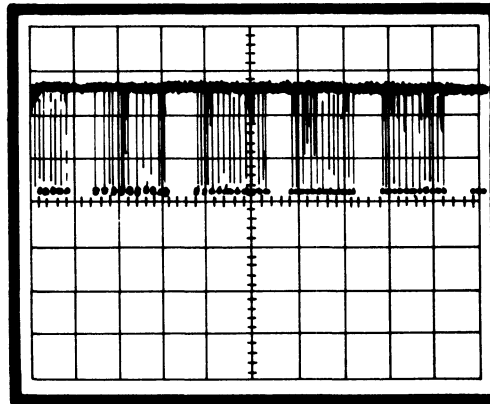

b. Low Volume

### SCOPE SETUP

VOLTS/DIV:	2V
VERTICAL MODE:	NORMAL
SWEEP SPEED:	0.2 MS/DIV
TRIG MODE:	NORMAL
TRIG SOURCE:	CHAN 1, DC, INT, POS

MA-4683

Figure 5-20 Bell Amplifier Input

4. Check output of bell amplifier by connecting channel 1 of scope to junction of diode D2 and R22 on logic and power board. With scope set-up as in Step 3, press CTRL G and check for the waveshape shown in Figure 5-21. If a waveform is present but is not the proper shape, speaker coil may be open. Perform Step 5 before replacing logic and power board.
5. Remove power from terminal. Disconnect P3. Check speaker coil by connecting an ohmmeter between pins 4 and 5 of P3. The reading should be  $8 \pm 2$  ohms.
6. Reconnect P3 to J3 on logic board. Disconnect scope leads and close lower rear panel on LA120.

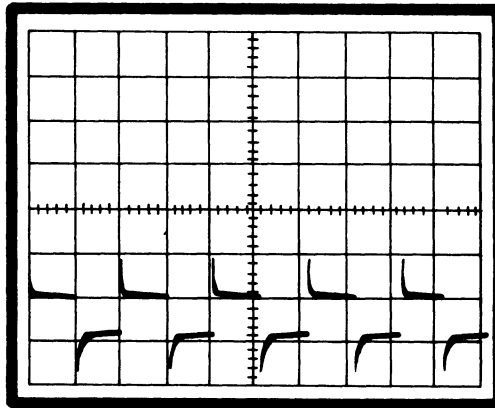

SCOPE SETUP

VOLTS/DIV:	2V
VERTICAL MODE:	NORMAL
SWEEP SPEED:	0.2 MS/DIV
TRIG MODE:	NORMAL
TRIG SOURCE:	CHAN 1, DC, INT, POS

MA-4681

Figure 5-21 Bell Amplifier Output



## **CHAPTER 6**

# **LA120 SUBASSEMBLY REMOVAL AND INSTALLATION**

### **6.1 GENERAL**

This chapter contains information pertaining to the removal and replacement of the mechanical and electrical subassemblies of the LA120.

Figure 6-1 lists all of the removal procedures in this chapter and the sequence in which these procedures are performed. As an example, Figure 6-1 illustrates that to remove the power entry bracket assembly, the power supply assembly removal procedure must be performed first.

DIGITAL Field Service recommends that the following LA120 assemblies be replaced in their entirety in a field environment.

- Print head assembly (Paragraph 6.3)
- Print head cable (Paragraph 6.4)
- Timing belt (Paragraph 6.5)
- Carriage assembly (Paragraph 6.7)
- Ribbon drive pulley (Paragraph 6.10)
- Ribbon drive assembly (Paragraph 6.11)
- DC motor and encoder assembly (Paragraph 6.14)
- Tractor drive shafts and tractor assemblies (Paragraph 6.15)
- Idler gear assembly (Paragraph 6.16)
- Stepping motor assembly (Paragraph 6.17)
- Ribbon chassis assembly (Paragraph 6.18)
- Keyboard/numeric pad assembly (Paragraph 6.20)
- Power supply assembly (Paragraph 6.21)
- Printer mechanism assembly (Paragraph 6.22)
- CVT power supply module (Paragraph 6.23)
- Power entry bracket assembly (Paragraph 6.24)
- Fan (Paragraph 6.25)
- Logic/power board (Paragraph 6.26)

### **6.2 PRINTER HOUSING**

The following procedure describes the removal and installation of the printer housing.

#### **6.2.1 Printer Housing Removal**

1. Remove power from printer by disconnecting ac plug.
2. Remove printer paper and printer cover.
3. Remove six (6-32) self-tapping screws and flat washers that secure printer housing to cabinet base (Figure 6-2) and set them aside.

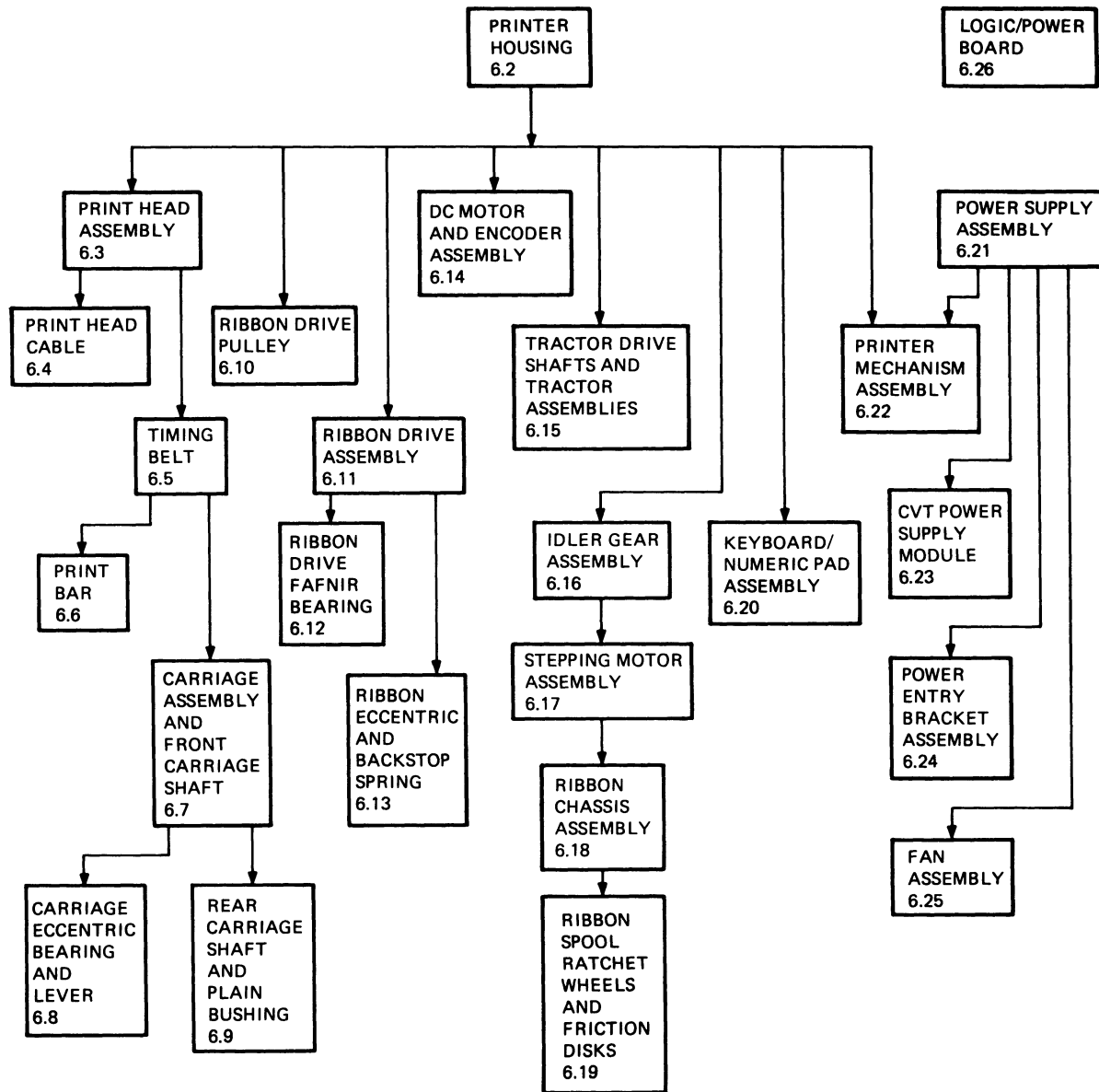

MA-2566A

Figure 6-1 Assembly Removal Sequence

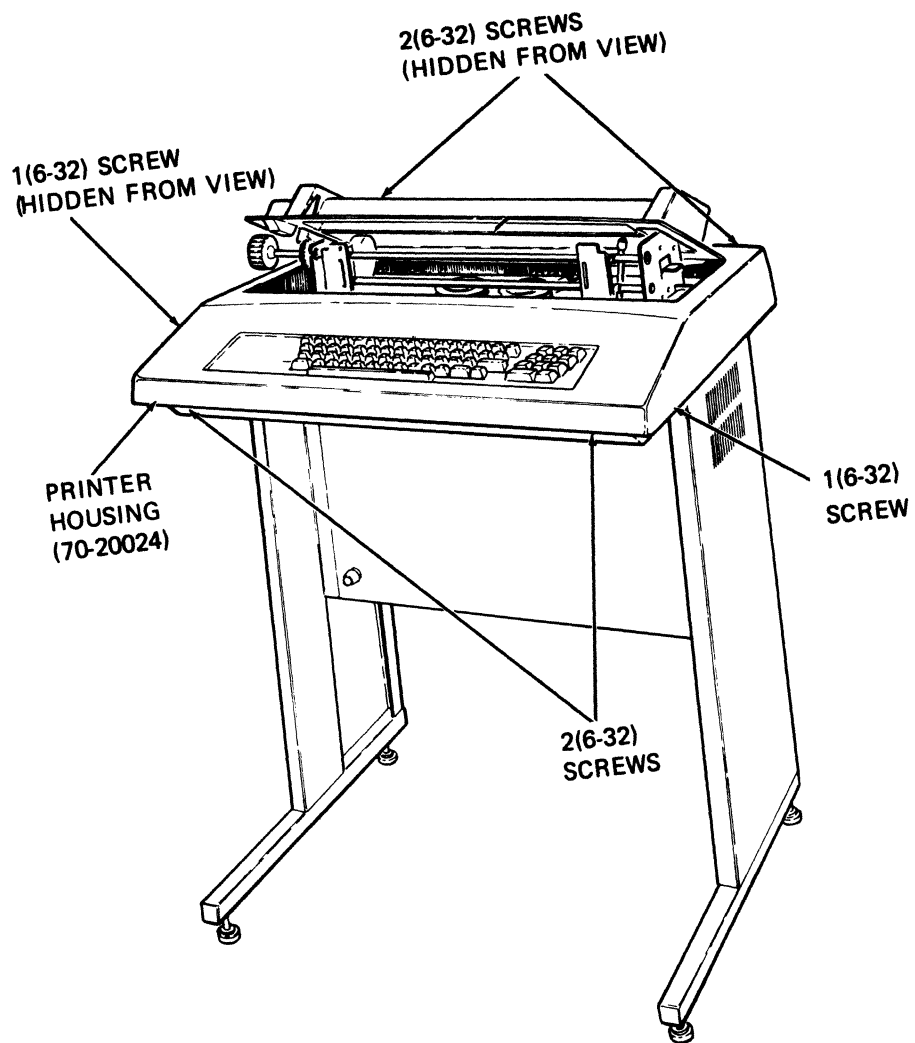

Figure 6-2 Printer Housing Removal and Installation

### 6.2.2 Printer Housing Installation

1. Place printer housing on cabinet base and secure it with six (6-32) self-tapping screws and flat washers.
2. Install printer paper and cover.
3. Restore power.

### 6.3 PRINT HEAD ASSEMBLY

The following procedure describes the removal and installation of the print head assembly. Refer to Figure 6-3 during the procedure.

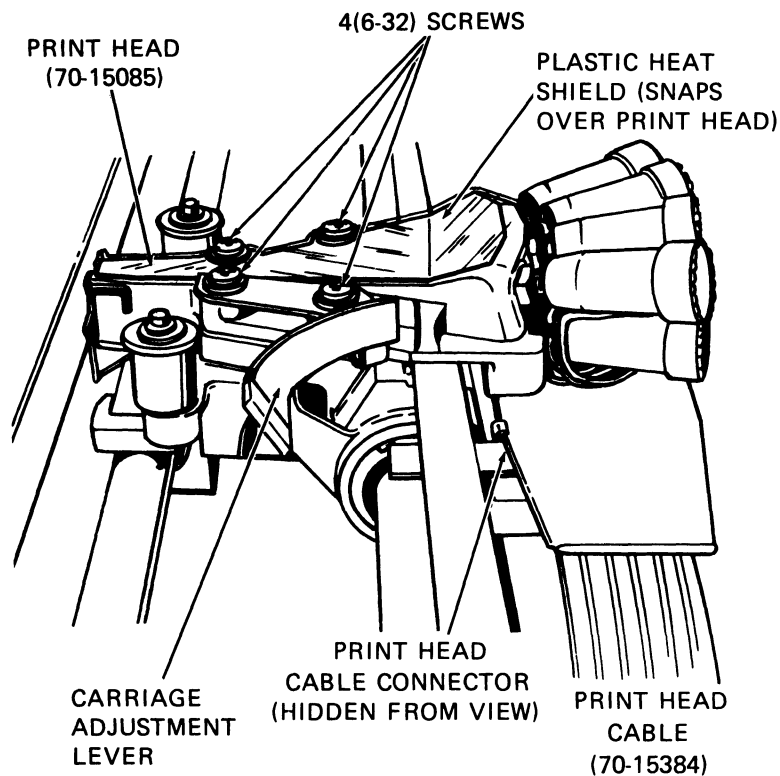

MA-2568

Figure 6-3 Print Head Removal and Installation

### 6.3.1 Print Head Assembly Removal

1. Perform printer housing removal procedure (Paragraph 6.2.1).
2. Remove ribbon.
3. Snap off print head heat shield.
4. Move carriage adjustment lever to the highest number (toward operator).
5. Remove the four (6-32) screws and washers that secure print head to carriage.
6. Disconnect print head cable connector from print head; then remove print head.

### 6.3.2 Print Head Assembly Installation

1. Connect print head cable to new print head.

#### CAUTION

**When installing print head, check to ensure that timing belt teeth mesh (seat) with slots in the carriage.**

2. Secure new print head with four (6-32) screws and washers. Make screws finger tight.
3. Move print head to the middle of print bar.
4. Set carriage adjustment lever to No. 1.

5. Manually push print head forward until it touches print bar.
6. Check to ensure that timing belt is aligned with pulley.
7. Tighten four (6-32) screws ( $10 \pm 2$  in/lb of torque).

**CAUTION**  
**Do not over-tighten the print head.**

8. Install print head heat shield.
9. Replace ribbon.
10. Slide carriage along carriage shaft to ensure that nothing is binding and that timing belt is aligned with pulleys.
11. Perform printer housing installation (Paragraph 6.2.2).

#### **6.4 PRINT HEAD CABLE**

The following procedure describes the removal and installation of the print head cable.

##### **6.4.1 Print Head Cable Removal**

1. Perform printer housing removal procedure (Paragraph 6.2.1).
2. Perform print head assembly removal procedure (Paragraph 6.3.1).

**CAUTION**  
**Removing and installing the print head cable, without removing print head, can damage print head connector.**

3. Disconnect cable from J6 (Figure 5-1) on logic/power board and remove it from cable clamps.

##### **6.4.2 Print Head Cable Installation**

1. Install one end of cable as shown in Figure 6-4.
2. Dress the other end of cable down through slot in rear of cabinet, and connect cable connector to J6 on logic/power board.
3. Perform print head assembly installation procedure (Paragraph 6.3.2).
4. Perform printer housing installation procedure (Paragraph 6.2.2).

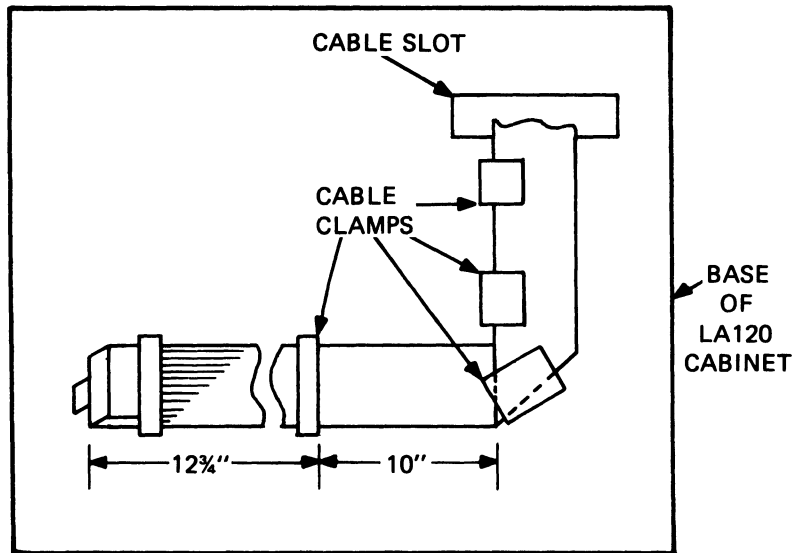

MA-2571

Figure 6-4 Print Head Cable

## 6.5 TIMING BELT

The following procedure describes the removal and installation of the timing belt.

### 6.5.1 Timing Belt Removal

1. Perform printer housing removal procedure (Paragraph 6.2.1).

#### NOTE

**The print head ribbon cable does not have to be disconnected when performing the following procedure.**

2. Perform print head assembly removal procedure (Paragraph 6.3.1).
3. Push carriage assembly to extreme left, and slip timing belt off dc motor pulley.

### 6.5.2 Timing Belt Installation

1. With belt tension spring in place (Figures 6-5 and 6-6), press left-hand pulley against printer mechanism and slip on the new timing belt.
2. Rotate timing belt screw (Figure 6-5) until it just touches ribbon drive assembly. Screws should not exert pressure on ribbon drive assembly.
3. Perform print head assembly installation procedure (Paragraph 6.3.2).
4. Perform printer housing installation procedure (Paragraph 6.2.2).

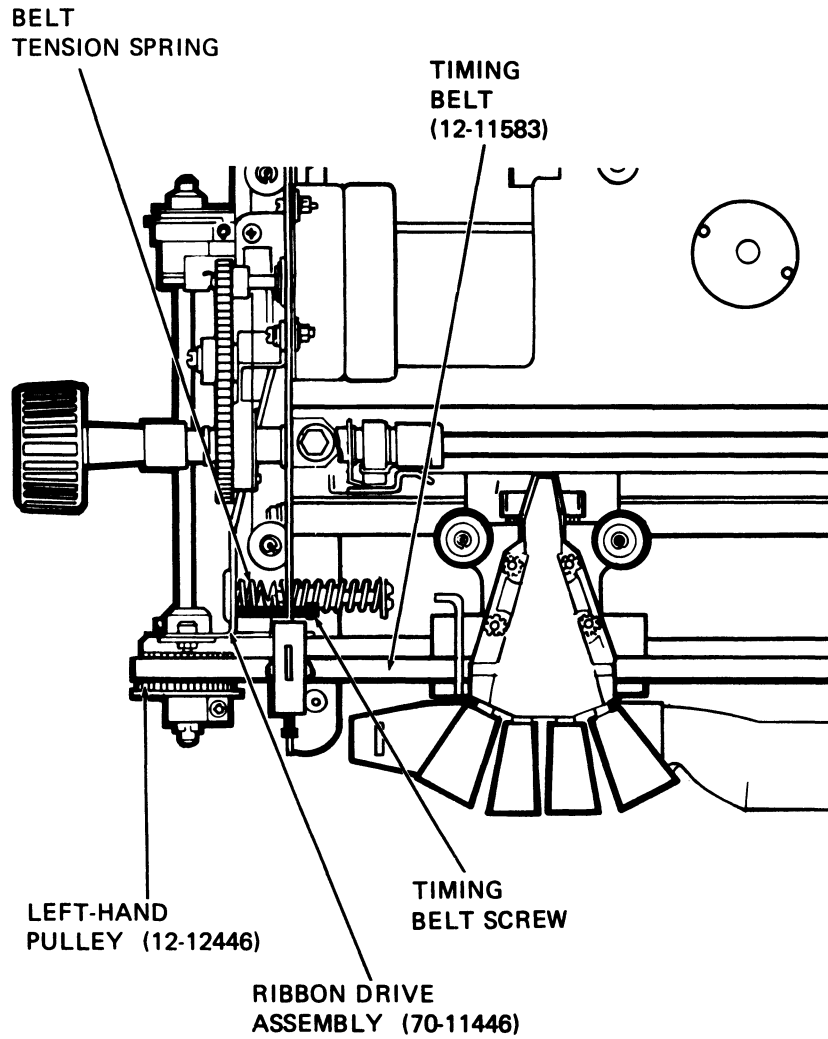

MA-2569

Figure 6-5 Belt Tension Spring Location

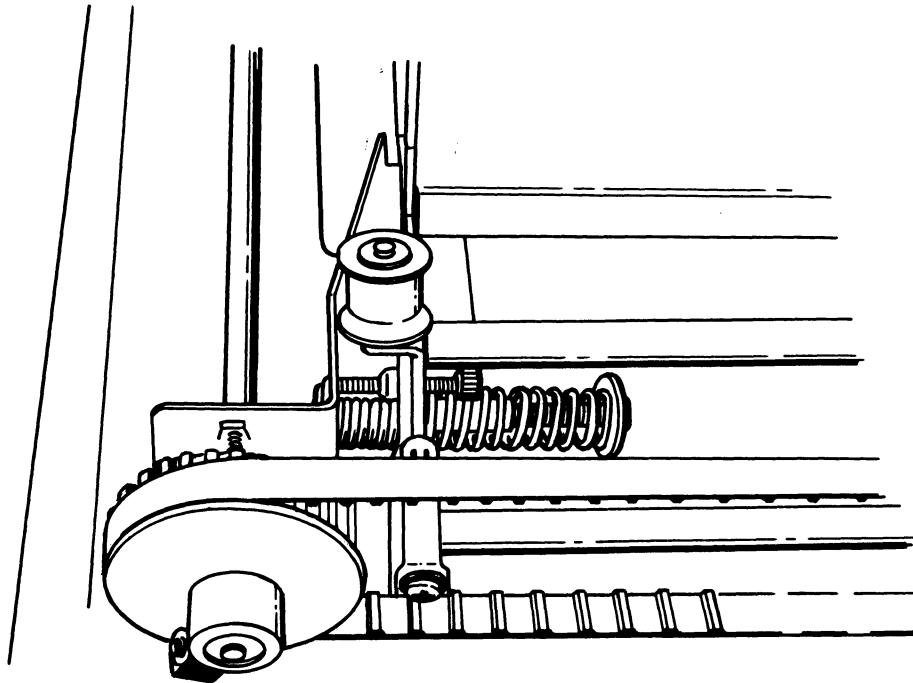

MA-2570

Figure 6-6 Belt Tension Spring (Detailed View)

## 6.6 PRINT BAR

### 6.6.1 Print Bar Removal

1. Perform timing belt removal procedure (Paragraph 6.5.1).
2. Move right-hand and left-hand tractors to their rightmost position.
3. Remove two 3/8 inch hex-head screws from the ends of the print bar (Figure 6-7a).
4. Remove print bar by carefully lifting left end of bar and moving it forward and toward the left. Ensure that bar does not hit ribbon idlers on carriage assembly or lower edge of tractors.

### 6.6.2 Print Bar Installation

1. Move the right-hand and left-hand tractors to their rightmost position.
2. Install print bar, right end first, being careful not to hit ribbon idlers on carriage assembly or lower edge of tractors.
3. Install two 3/8 inch hex-head screws into the ends of the print bar.
4. Perform print bar adjustment procedure (Paragraph 7.9).
5. Perform timing belt installation procedure (Paragraph 6.5.2).



## 6.7 CARRIAGE ASSEMBLY AND FRONT CARRIAGE SHAFT

The following procedure describes the removal and installation of the carriage assembly and front carriage shaft.

### 6.7.1 Carriage Assembly and Front Carriage Shaft Removal

1. Remove power by unplugging LA120 power cord.
2. Perform printer housing removal procedure (Paragraph 6.2.1).
3. Unsnap keyboard bezel to enable easy access to carriage shaft clamp screws (Figure 6-7a).
4. Perform print head removal procedure (Paragraph 6.3.1).
5. Perform timing belt removal procedure (Paragraph 6.5.1).
6. Loosen two (8-32) front carriage clamp screws (Figure 6-7a).
7. Using a screwdriver, pry the top of the right carriage shaft clamp up and to the right as shown in Figure 6-7b.

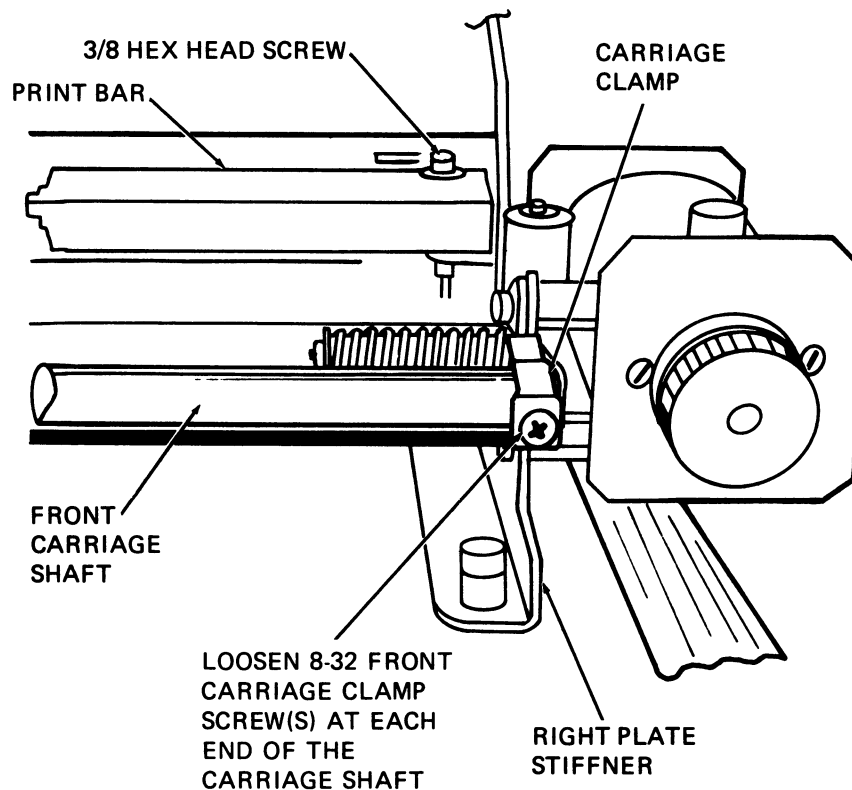

#### a. Carriage Shaft Clamp Screws

MA-2590A

Figure 6-7 Carriage Assembly and Front Carriage Shaft Removal and Installation (Sheet 1 of 2)

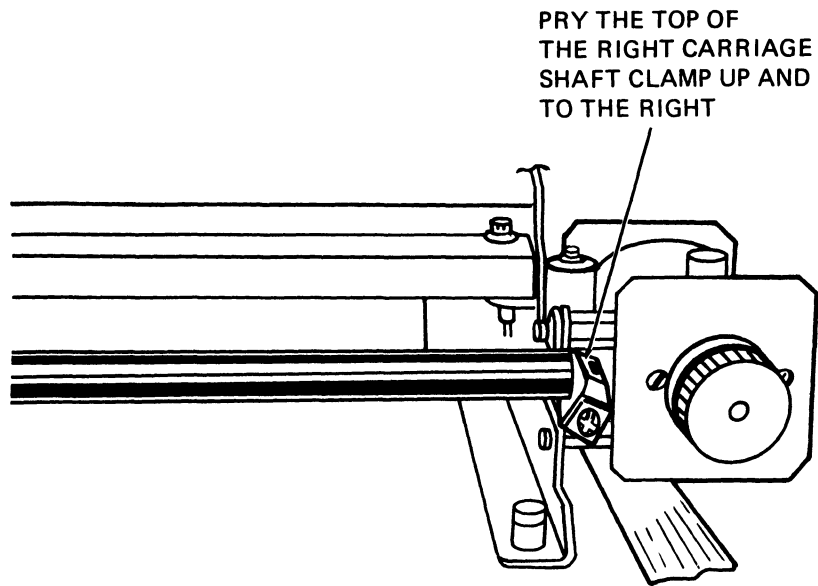

MA-2591

b. Prying Up Carriage Shaft Clamp

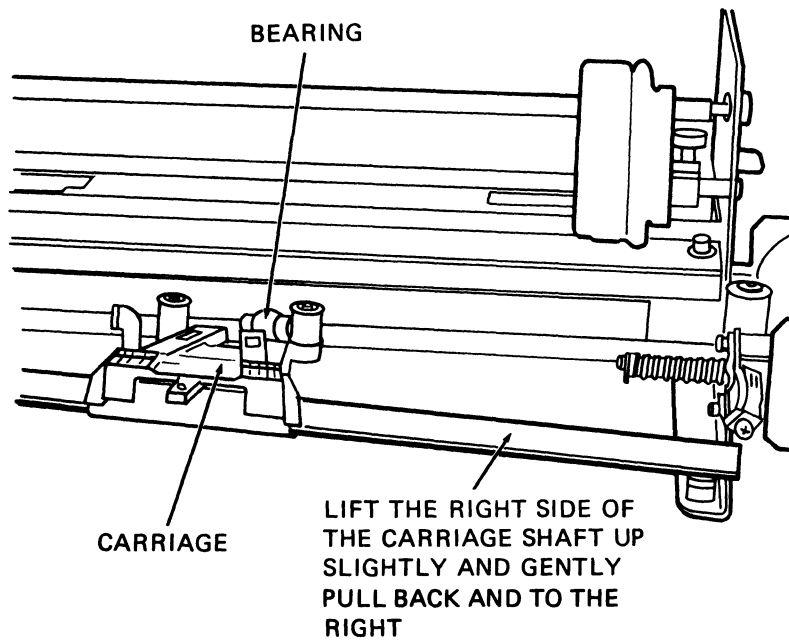

MA-2592

c. Lifting Front Carriage Shaft

Figure 6-7 Carriage Assembly and Front Carriage Shaft  
Removal and Installation (Sheet 2 of 2)

8. To remove carriage and carriage shaft, lift right side of the carriage shaft up slightly and gently pull back and to the right as shown in Figure 6-7c.
9. Remove carriage from carriage shaft.

### **6.7.2 Carriage Assembly and Front Carriage Shaft Installation**

1. Place new carriage on carriage shaft.
2. Slide left side of carriage shaft into carriage shaft clamp.
3. Align carriage and bearing and snap the right side of the carriage shaft into carriage shaft clamp. Ensure that carriage shaft clamp is seated properly.
4. Tighten left and right 8-32 carriage clamp screws,  $18 \pm 2$  in/lbs of torque.
5. Holding belt tension spring in place (Figure 6-6), slip on the timing belt.
6. Replace keyboard bezel on cabinet base and secure by pressing in two sides of bezel to engage mounting slots. Check keyboard connectors to ensure they are properly seated.
7. Perform timing belt installation procedure (Paragraph 6.5.2).
8. Perform print head installation procedure (Paragraph 6.3.2).
9. Perform the printer housing installation procedure (Paragraph 6.2.2).

## **6.8 CARRIAGE ECCENTRIC BEARING AND LEVER**

Refer to Figure 6-8 during the removal and installation procedures.

### **6.8.1 Carriage Eccentric Bearing and Lever Removal**

1. Remove carriage assembly (Paragraph 6.7.1).
2. Remove carriage spring holding eccentric bearing in place. Spring is removed by pressing up on spring while pushing spring tab toward rear of carriage assembly.
3. Remove eccentric bearing.
4. Pull lever off the end of the eccentric bearing.

### **6.8.2 Carriage Eccentric Bearing and Lever Installation**

1. Press lever onto end of eccentric bearing with stop detents facing in toward carriage assembly.
2. Place eccentric bearing in carriage assembly with lever dial toward top of carriage assembly. Place oil on the eccentric bearing where carriage spring rubs against it.
3. Install carriage spring by pressing up on spring until spring tab snaps into place.
4. Install carriage assembly (Paragraph 6.7.2).

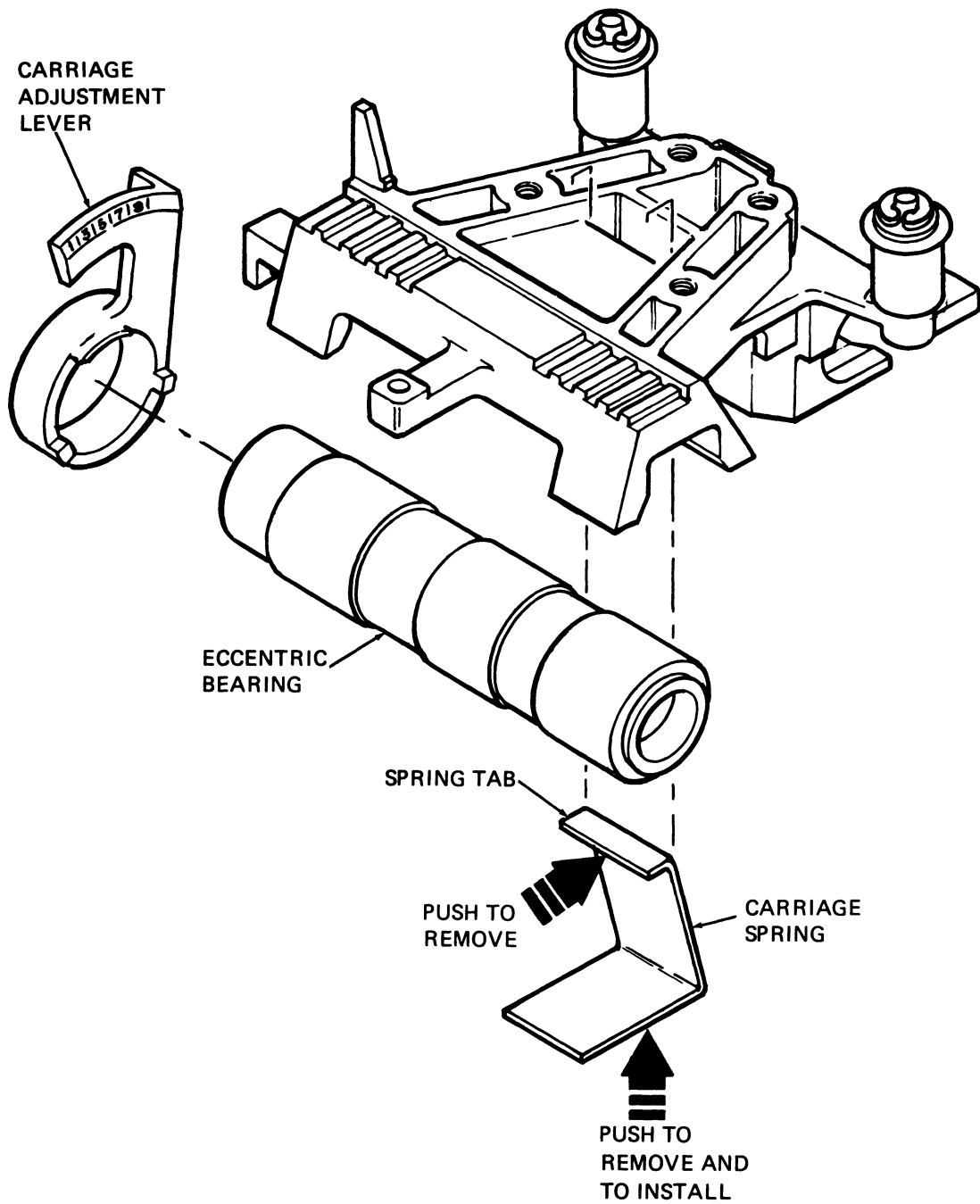

MA-4507

Figure 6-8 Carriage Eccentric Bearing and Lever  
Removal and Installation

## 6.9 REAR CARRIAGE SHAFT AND PLAIN BUSHING

Refer to Figure 6-9 during the removal and installation procedures.

### 6.9.1 Rear Carriage Shaft and Plain Bushing Removal

1. Remove carriage assembly and front carriage shaft (Paragraph 6.7.1).
2. Separate ribbon chassis assembly from right end plate by removing 1/4 inch hex-head screw and two Phillips screws.
3. Separate print bar from right end plate by removing 3/8 inch hex-head screw from right end of the print bar.

#### NOTE

Try not to move print bar. Do not loosen screw on left end of print bar.

4. Separate right end plate from printer frame by removing two 5/16 inch hex-head mounting screws from underneath frame.
5. Carefully work right end plate toward the right until right end of the rear carriage shaft slips out of right end plate. Support right end of the upper tractor shaft, which will slip out of its bearing when right plate is moved.
6. Slide plain bushing off rear carriage shaft.
7. Carefully work rear carriage shaft out of left end plate.

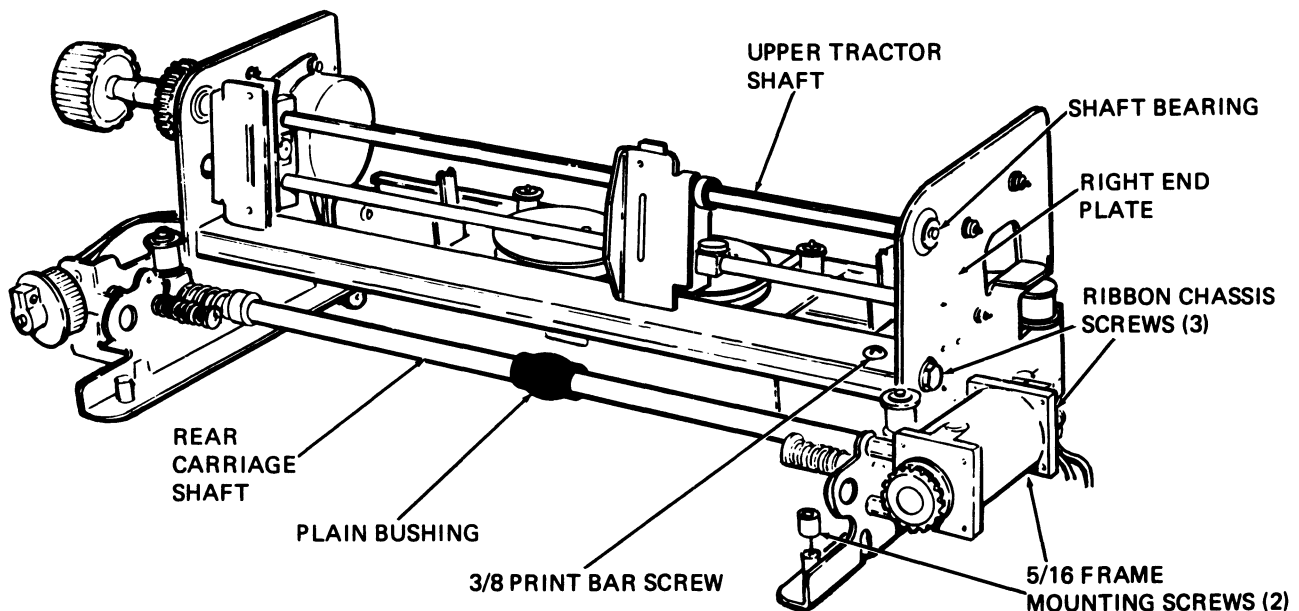

MA-4508

Figure 6-9 Rear Carriage Shaft and Plain Bushing Removal and Installation

### **6.9.2 Rear Carriage Shaft and Plain Bushing Installation**

1. Slip rear carriage shaft into shaft hole in left end plate.
2. Slide plain bushing onto rear carriage shaft.
3. Work right end plate into position while simultaneously inserting right end of rear carriage shaft and right end of upper tractor shaft into right end plate.
4. Attach right end plate to printer frame by installing two 5/16 inch hex-head mounting screws underneath frame.
5. Attach print bar to right end plate by installing 3/8 inch hex-head screw into right end of print bar.

**NOTE**  
**Try not to move print bar.**

6. Attach ribbon chassis assembly to right end plate with 1/4 inch hex-head screw and two Phillips head screws.
7. Install carriage assembly and front carriage shaft (Paragraph 6.7.2).
8. Check print bar adjustment (Paragraph 7.9).

### **6.10 RIBBON DRIVE PULLEY**

The following procedure describes the removal and installation of the ribbon drive pulley. Refer to Figure 6-10 during the procedure.

#### **6.10.1 Ribbon Drive Pulley Removal**

1. Perform printer housing removal procedure (Paragraph 6.2.1).
2. Slip timing belt off dc motor pulley.
3. Loosen 6-32 Allen-cap screw that secures collar clamp and drive pulley to ribbon drive shaft. Remove collar clamp and drive pulley.

#### **6.10.2 Ribbon Drive Pulley Installation**

1. Remove collar clamp from defective pulley and hand press it onto new drive pulley. Line up front edges of collar clamp and drive pulley.
2. Replace ribbon drive pulley and collar clamp on ribbon drive shaft and adjust them to give a clearance of  $0.38 \pm 0.03$  inch between ribbon drive bracket and ribbon drive pulley. Tighten 6-32 screw to  $12 \pm 2$  in/lb of torque.
3. Slip timing belt onto pulley.
4. Perform printer housing installation procedure (Paragraph 6.2.2).

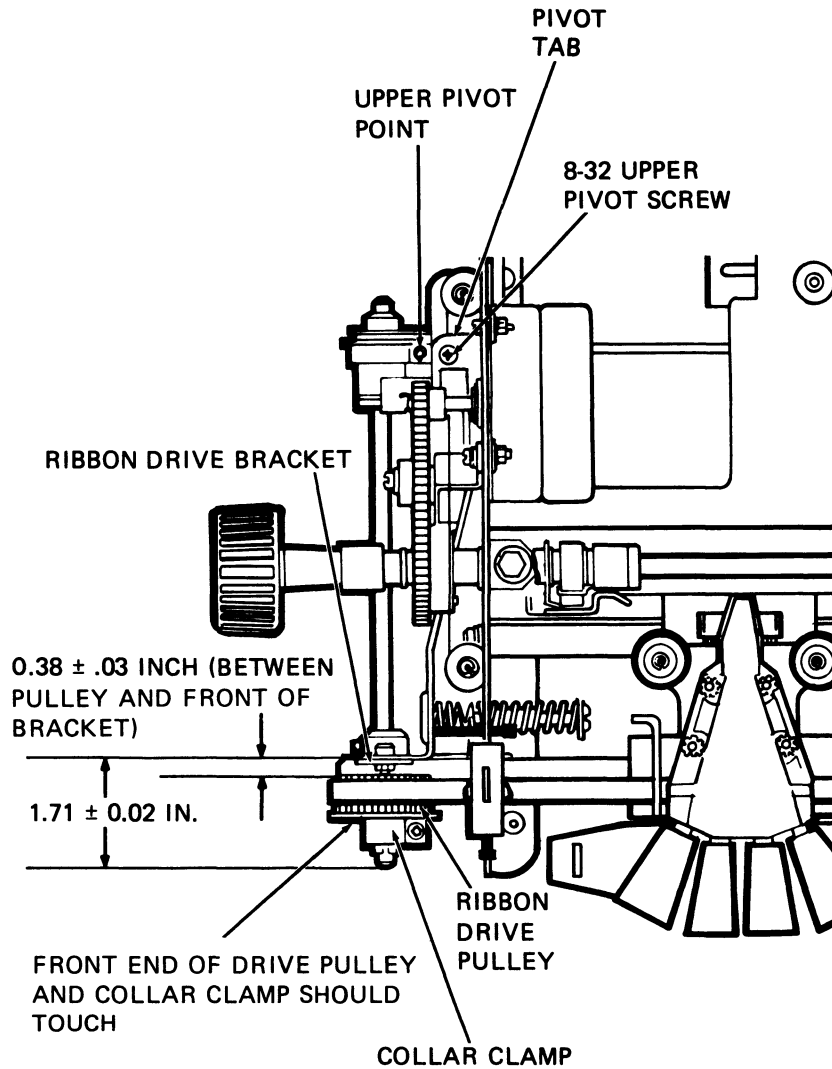

Figure 6-10 Ribbon Drive Pulley Removal and Installation

## 6.11 RIBBON DRIVE ASSEMBLY

The following procedure describes the removal and installation of the ribbon drive assembly. Refer to Figures 6-11 and 6-12 during the procedure.

### 6.11.1 Ribbon Drive Assembly Removal

1. Perform printer housing removal procedure (Paragraph 6.2.1).
2. Remove ribbon spools and ribbon.
3. Slip timing belt off dc motor pulley.
4. Lift up pushrod and remove retaining ring that holds pushrod in ribbon chassis.
5. Rotate ribbon drive pulley until clutch eccentric is at its highest point.

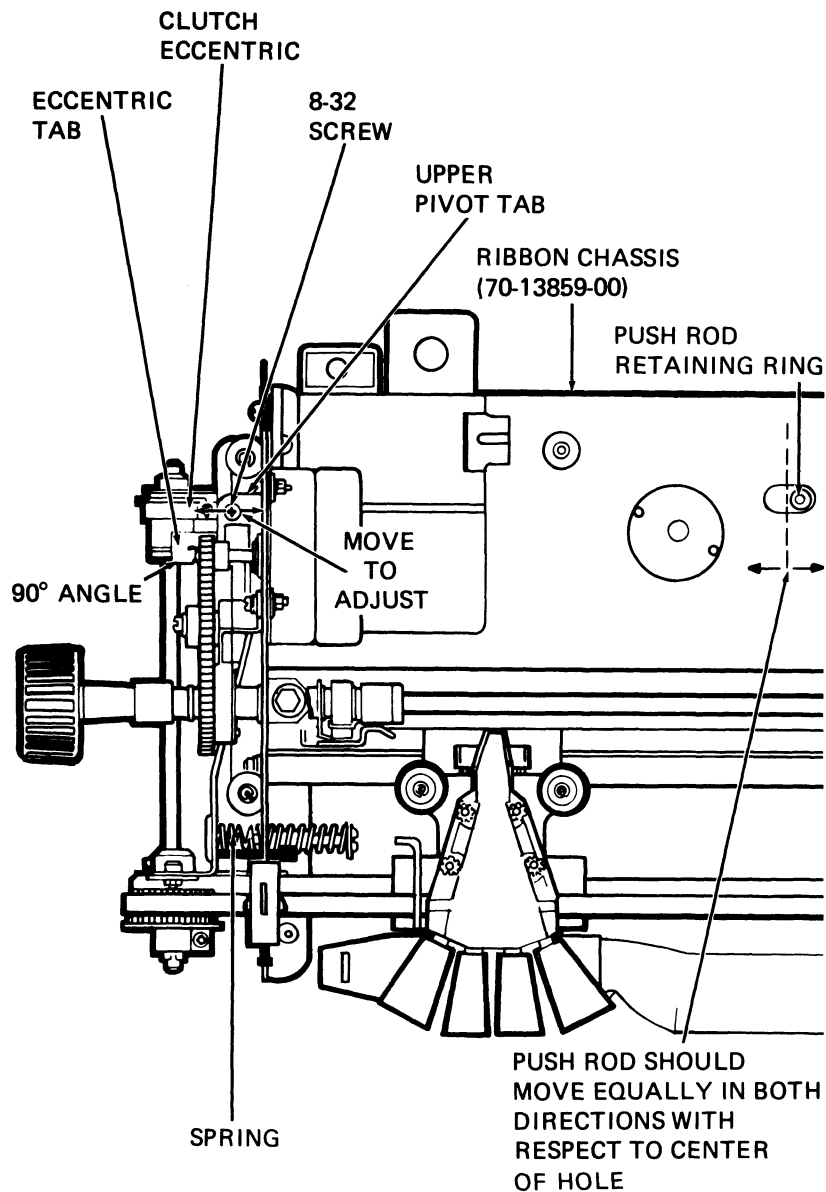

MA-2572

Figure 6-11 Ribbon Drive Assembly Removal and Installation

6. Remove 8-32 screw and washer that secure ribbon drive to upper pivot tab on left-hand side plate.
7. Remove ribbon drive by pulling out at top. This will free assembly from upper pivot tab. Lift up on ribbon drive to clear lower pivot.

**NOTE**

**The nut on the ribbon drive assembly is loose and can be lost easily.**

8. Carefully remove ribbon drive assembly and pushrod.



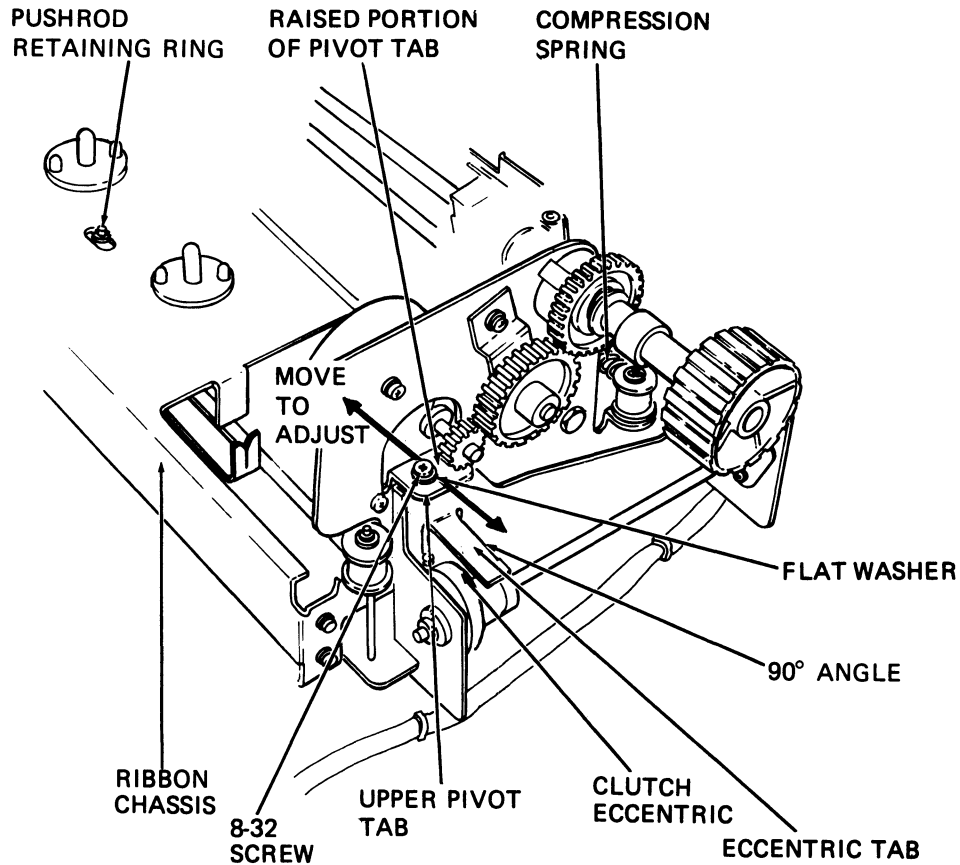

MA-2573

Figure 6-12 Ribbon Drive Assembly (Detailed View)

### 6.11.2 Ribbon Drive Assembly Installation

1. Rotate the ribbon drive pulley on new ribbon drive assembly until clutch eccentric is at its highest point.

**NOTE**

**Ensure that PAPER OUT switch wires are under pushrod when installing ribbon drive assembly.**

2. Push pushrod through left-hand side plate.
3. Push rear of drive assembly toward side plate and engage lower pivot point.
4. Slide upper pivot under pivot tab on side plate and secure it with 8-32 screw and flat washer. Make screw finger tight.
5. Replace retaining ring that holds pushrod in ribbon chassis.
6. Insert compression spring between left-hand side plate and ribbon drive.
7. Replace timing belt on ribbon drive pulley and dc motor pulley.

8. Rotate ribbon drive and check pushrod travel to either side of center of the elongated slot in the ribbon chassis. Travel should be equal on either side of center.
9. To attain equal travel from center, move ribbon drive upper pivot point in direction of the shortest distance of travel. When travel is equal on both sides of the elongated hole, tighten 8-32 upper pivot screw to  $18 \pm 2$  in/lb of torque.

**NOTE**

**Check that eccentric tab is bent at a 90 degree angle when viewed from the left side of unit. If angle is not 90 degrees, bend it to correct angle. This is done to prevent tab from touching spring. Clearance should be 0.254 to 0.508 mm (0.010 to 0.020 in).**

10. Replace ribbon and ribbon spools.
11. Perform printer housing installation procedure (Paragraph 6.2.2).

### **6.12 RIBBON DRIVE FAFNIR BEARING**

The following procedure describes the removal and installation of the ribbon drive Fafnir bearing. Refer to Figure 6-13 during the procedure. To perform this procedure, the ribbon drive assembly must be removed.

#### **6.12.1 Ribbon Drive Fafnir Bearing Removal**

1. Perform ribbon drive assembly removal procedure (Paragraph 6.11.1).
2. Loosen 6-32 Allen head screw that secures collar clamp and drive pulley to ribbon drive shaft. Remove collar clamp and drive pulley (Figure 6-10).
3. Remove two (8-32) screws, nuts, and lockwashers that secure Fafnir bearing to ribbon drive bracket.
4. Loosen 4-40 set screw that secures Fafnir bearing on ribbon drive shaft.
5. While rotating ribbon drive shaft counterclockwise, push shaft toward rear of ribbon drive assembly until it clears ribbon drive bracket. (Always turn shaft in a counterclockwise direction when pushing through the one-way clutch.)
6. Remove Fafnir bearing from ribbon drive shaft and set bearing aside.

#### **6.12.2 Ribbon Drive Fafnir Bearing Installation**

1. Place new Fafnir bearing on ribbon drive shaft and push shaft toward pulley end of ribbon drive until Fafnir bearing can be seated in ribbon drive bracket. (Always turn shaft in a counterclockwise direction when pushing through the one-way clutch.)
2. Secure Fafnir bearing to ribbon drive bracket with two (8-32) screws, nuts, and lockwashers. The nuts go on outside of ribbon drive bracket.
3. Slide ribbon drive shaft toward front of ribbon drive until it extends  $1.71 \pm 0.02$  inch beyond ribbon drive bracket (Figure 6-10). Tighten 4-40 set-screw in Fafnir bearing to  $8 \pm 1$  in/lb of torque. (The set-screw sets into a recessed dimple in Fafnir bearing split collar.) Turn shaft in a clockwise direction to ensure freedom of movement.

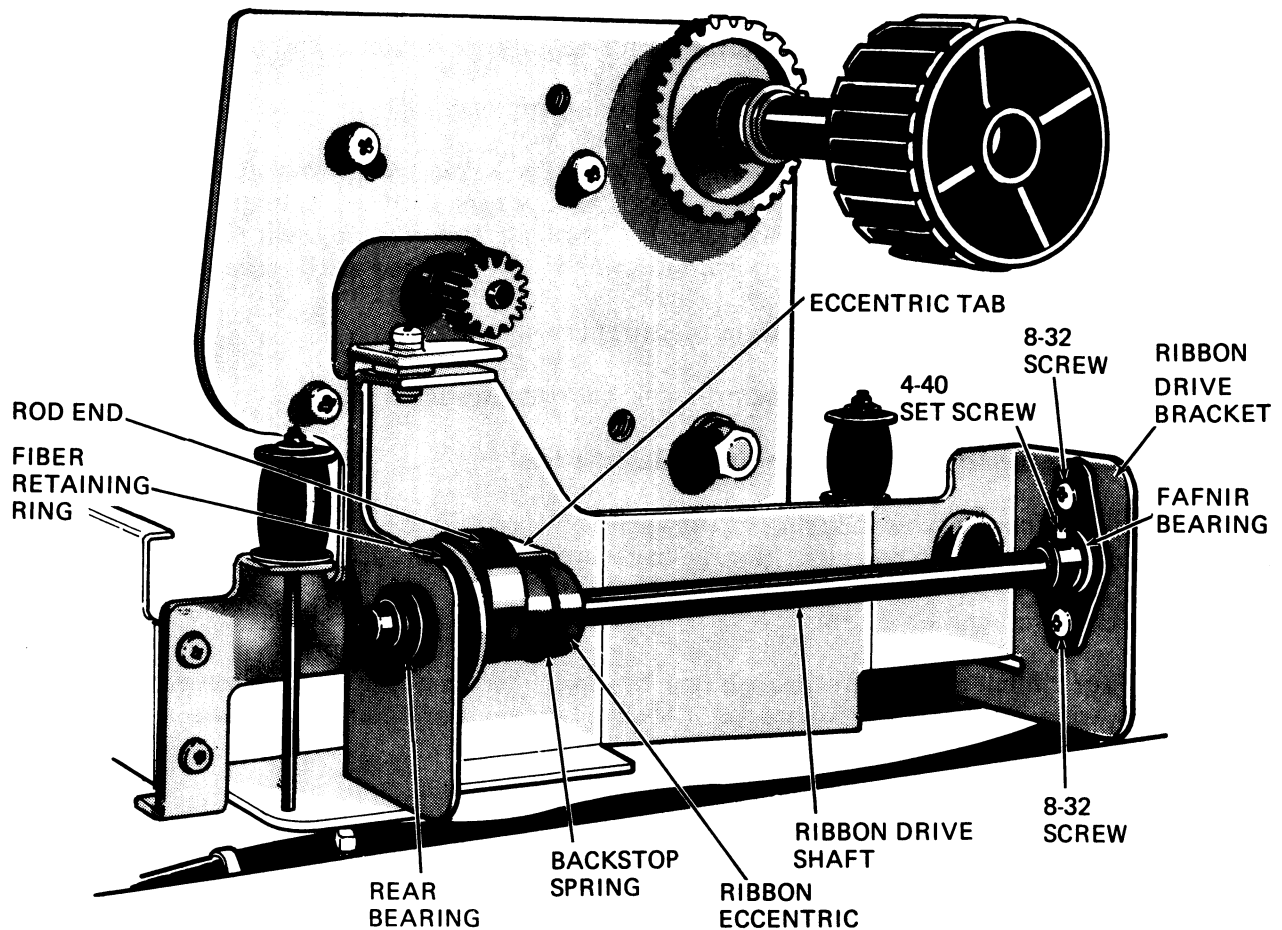

MA-4694

Figure 6-13 Fafnir Bearing and Ribbon Eccentric Removal and Installation

4. Replace ribbon drive pulley and collar clamp on ribbon drive shaft and adjust them to give a clearance of  $0.38 \pm 0.03$  inch between ribbon drive bracket and ribbon drive pulley. Tighten 6-32 Allen head screw in collar clamp to  $12 \pm 2$  in/lb of torque.
5. Check that backstop spring coils do not overlap.
6. Perform ribbon drive assembly installation procedure (Paragraph 6.11.2).

### 6.13 RIBBON ECCENTRIC AND BACKSTOP SPRING

The following procedure describes the removal and installation of the ribbon eccentric and backstop spring. Refer to Figure 6-13 during the procedure. To perform this procedure the ribbon drive assembly must be removed.

#### 6.13.1 Ribbon Eccentric and Backstop Spring Removal

1. Perform ribbon drive assembly removal procedure (Paragraph 6.11.1).
2. Loosen 6-32 Allen head screw that secures collar clamp and drive pulley to ribbon drive shaft. Remove collar clamp and drive pulley (Figure 6-10).

3. Loosen 4-40 set screw that secures Fafnir bearing on ribbon drive shaft.
4. Remove retaining ring that holds pushrod in rod end.
5. While rotating ribbon drive shaft counterclockwise, push shaft toward rear of ribbon drive assembly until it is completely removed. (Always turn shaft in a counterclockwise direction when pushing through one-way clutch.) The fiber retaining ring will fall free. Support the ribbon eccentric and backstop spring which is still attached to the eccentric tab.
6. Disengage backstop spring from eccentric tab.
7. Separate rod end, ribbon eccentric, and backstop spring.

#### **6.13.2 Ribbon Eccentric and Backstop Spring Installation**

1. Install (new) backstop spring on (new) ribbon eccentric. Apply one drop of No. 30 SAE oil on spring and on eccentric. Engage backstop spring with eccentric tab.
2. Install rod end on eccentric.
3. Slide ribbon drive shaft through rear bearing, fiber retaining ring, ribbon eccentric, Fafnir bearing, and ribbon drive bracket. (Always turn shaft in a counterclockwise direction when pushing through the one-way clutch.)
4. Slide pushrod into rod end and replace retaining ring.
5. Slide ribbon drive shaft toward front of ribbon drive until it extends  $1.71 \pm 0.02$  inch beyond ribbon drive bracket (Figure 6-10). Tighten 4-40 set-screw in Fafnir bearing to  $8 \pm 1$  in/lb of torque. (The set-screw sets into a recessed dimple in Fafnir bearing split collar.) Turn shaft in a clockwise direction to ensure freedom of movement.
6. Replace ribbon drive pulley and collar clamp on ribbon drive shaft and adjust them to give a clearance of  $0.38 \pm 0.03$  inch between ribbon drive bracket and ribbon drive pulley (Figure 6-10). Tighten 6-32 Allen head screw in collar clamp to  $12 \pm 2$  in/lb of torque.
7. Check that backstop spring coils do not overlap.
8. Perform ribbon drive assembly installation procedure (Paragraph 6.11.2).

#### **6.14 DC MOTOR AND ENCODER ASSEMBLY**

The following procedure describes the removal and installation of the dc motor and encoder assembly. Refer to Figure 6-14 during the procedure.

##### **6.14.1 DC Motor and Encoder Assembly Removal**

1. Perform printer housing removal procedure (Paragraph 6.2.1).
2. Slip timing belt off dc motor pulley.
3. Open rear access door on cabinet.
4. Disconnect connectors from J5 and J7 on the logic/power board (Figure 5-1).

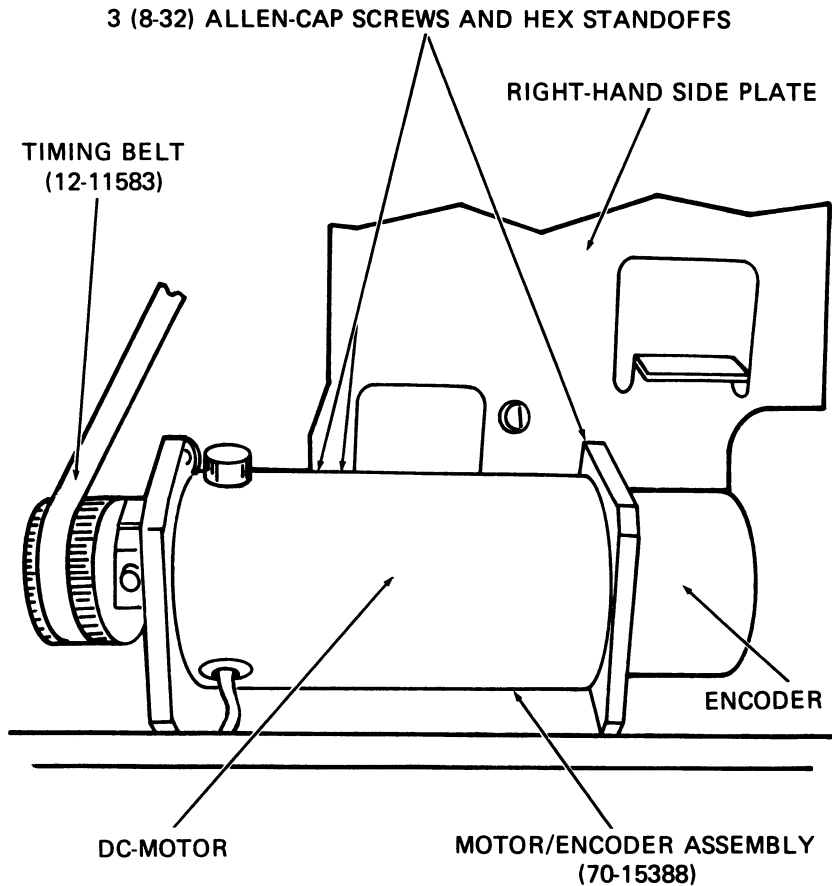

MA-2575

Figure 6-14 DC Motor/Encoder Assembly Removal and Installation

5. Remove three (8-32) Allen-cap screws and hex standoffs that secure dc motor to right-hand side plate and remove motor.

#### 6.14.2 DC Motor and Encoder Assembly Installation

1. Secure new dc motor to right-hand side plate with three (8-32) Allen-cap screws and hex standoffs. Tighten screws to  $18 \pm 2$  in/lb.
2. Thread dc motor and encoder cables down through slot at rear of cabinet.
3. Secure cables with cable ties where needed. Reconnect connectors to J5 and J7 on logic/power board.
4. With belt tension spring (Figure 6-5) in place, press left-hand pulley against printer mechanism and slip on new timing belt.
5. Perform printer housing installation procedure (Paragraph 6.2.2).

## 6.15 TRACTOR DRIVE SHAFTS AND TRACTOR ASSEMBLIES

The following procedure describes the removal and installation of tractor drive shafts and tractor assemblies. Tractor assemblies slip off the drive shafts once the shafts are removed. Refer to Figure 6-15 during the procedure.

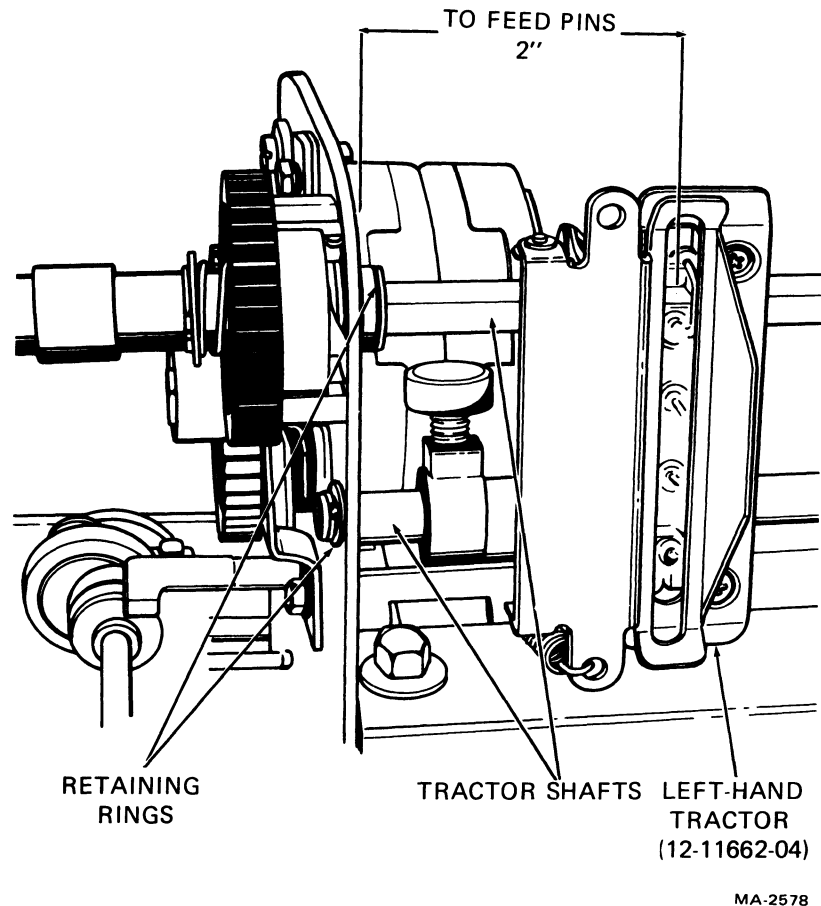

MA-2578

Figure 6-15 Tractor Drive Shaft and Tractor Assembly Removal and Installation

### 6.15.1 Tractor Drive Shaft and Tractor Assembly Removal

1. Perform printer housing removal procedure (Paragraph 6.2.1).
2. Loosen tractor adjustments knob on both tractors.

#### NOTE

The spring clip on the outside of the lower tractor support shaft is loose and may fall off when performing the following step.

3. Remove two retaining rings on left-hand side of tractor support shaft and drive shaft.
4. Slide both shafts to left about 10.16 cm (4 in) to remove the tractor assemblies. Pull shafts (to the left) out of the left-hand end plate to remove shafts.

### 6.15.2 Tractor Drive Shaft and Tractor Assembly Installation

1. Replace defective tractor or drive shaft.
2. Slide two tractor shafts halfway through left-side plate.
3. Slide tractor assemblies on tractor shafts.
4. Ensure that index marks on outside of upper tractor bushings coincide with same flat on square shaft (Figure 6-16). If bushings are not scribed, rotate tractors until a tractor pin on both tractors is centered on the same flat.

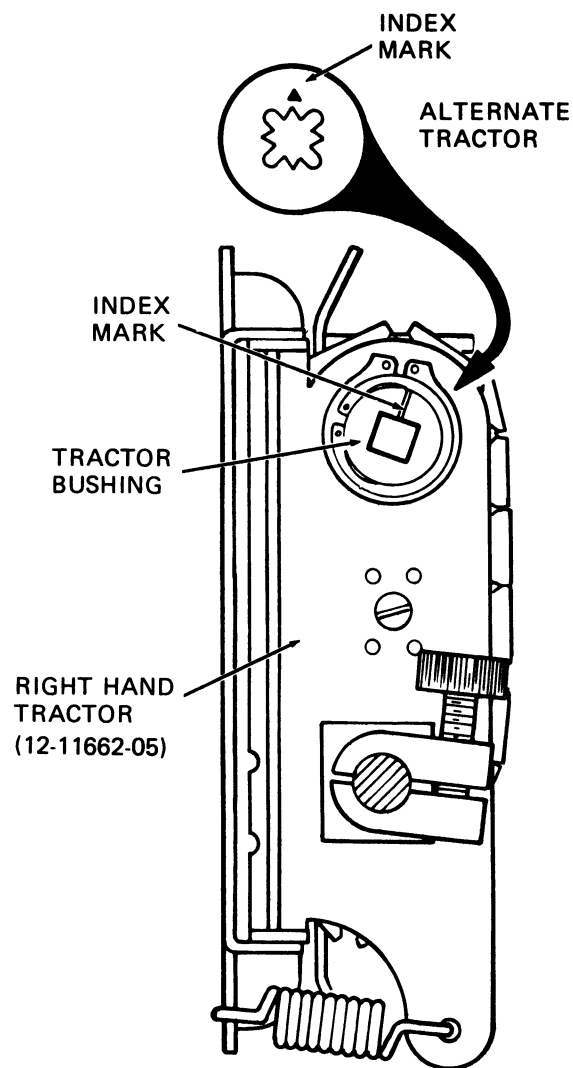

TRACTOR PHASING

MA-2579

Figure 6-16 Tractor Phasing Adjustment

5. Position tractor shafts in side plates and secure them with three retaining rings.
6. Slide left-hand tractor from side to side. If it appears to bind or have excessive drag on the shafts, grasp bottom tractor shaft and move it up or down in its slot until tractor slides easily on shafts.
7. Slide left-hand tractor to left so that feed pins are 53.975 mm (2.112 ± 0.03 in) from left-hand side plate.
8. The right-hand tractor is adjusted to the width of paper or form to be used.
9. Perform printer housing installation procedure (Paragraph 6.2.2).

### 6.16 IDLER GEAR ASSEMBLY

The following procedure describes the removal and installation of the idler gear assembly. Refer to Figure 6-17 during the procedure.

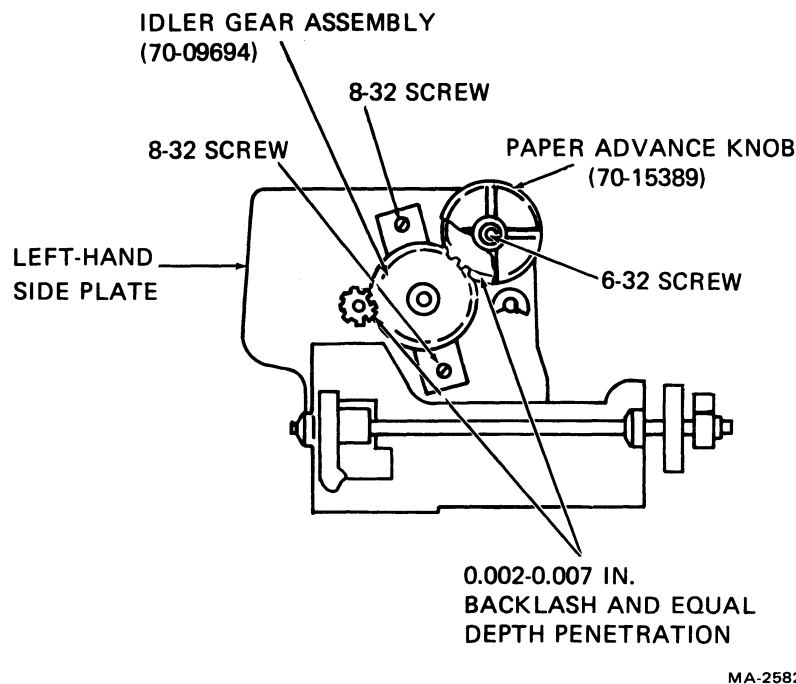

Figure 6-17 Idler Gear Assembly Removal and Installation

#### 6.16.1 Idler Gear Assembly Removal

1. Perform printer housing removal procedure (Paragraph 6.2.1).
2. Remove two (8-32) screws, lockwashers, and flat washers that secure idler gear assembly to left-hand side plate.

#### 6.16.2 Idler Gear Assembly Installation

1. Secure new idler gear assembly to left-hand side plate with two (8-32) screws, lockwashers, and flat washers. Make screws finger tight.



2. With idler gear in mesh with stepping motor gear and tractor drive gear, adjust idler gear to achieve equal depth penetration and a backlash\* of 0.0508 to 0.1778 mm (0.002 to 0.007 in) between each pair of gears. The idler gear should be free to slide in and out. Rotate gears to check backlash in several places.
3. Tighten two (8-32) screws to  $18 \pm 2$  in/lb of torque.
4. Rotate paper advance knob to ensure that gears turn freely.
5. Perform printer housing installation procedure (Paragraph 6.2.2).

## 6.17 STEPPING MOTOR ASSEMBLY

The following procedure describes the removal and installation of the stepping motor. The idler gear assembly must be removed to remove the stepping motor assembly. Refer to Figures 6-18 and 6-19 during the procedure.

### 6.17.1 Stepping Motor Assembly Removal

1. Perform printer housing removal procedure (Paragraph 6.2.1).
2. Perform idler gear assembly removal procedure (Paragraph 6.16.1).
3. Open rear access door.

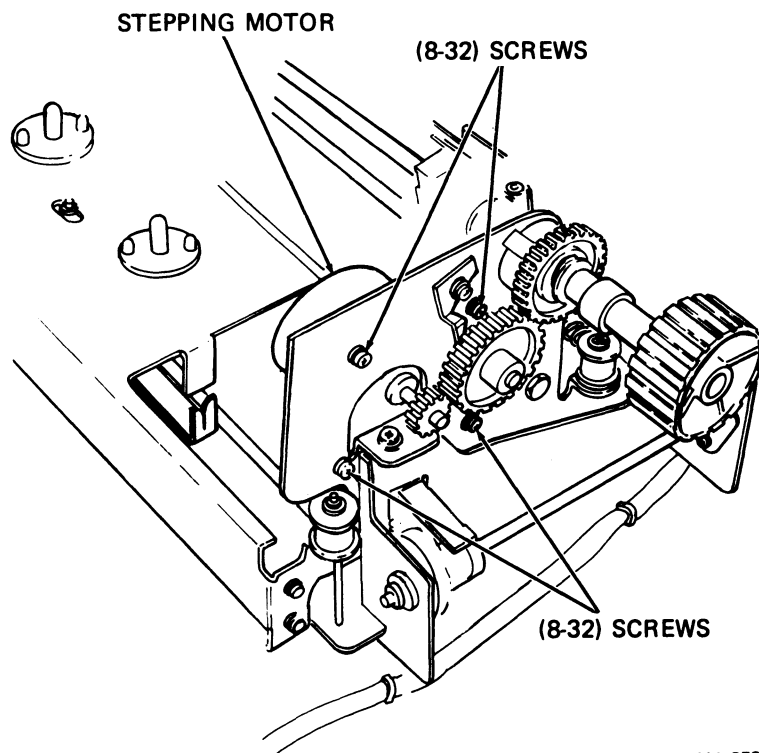

MA-2583

Figure 6-18 Stepping Motor Assembly Removal and Installation

\*Backlash is the amount a gear turns prior to turning the gear it meshes with.

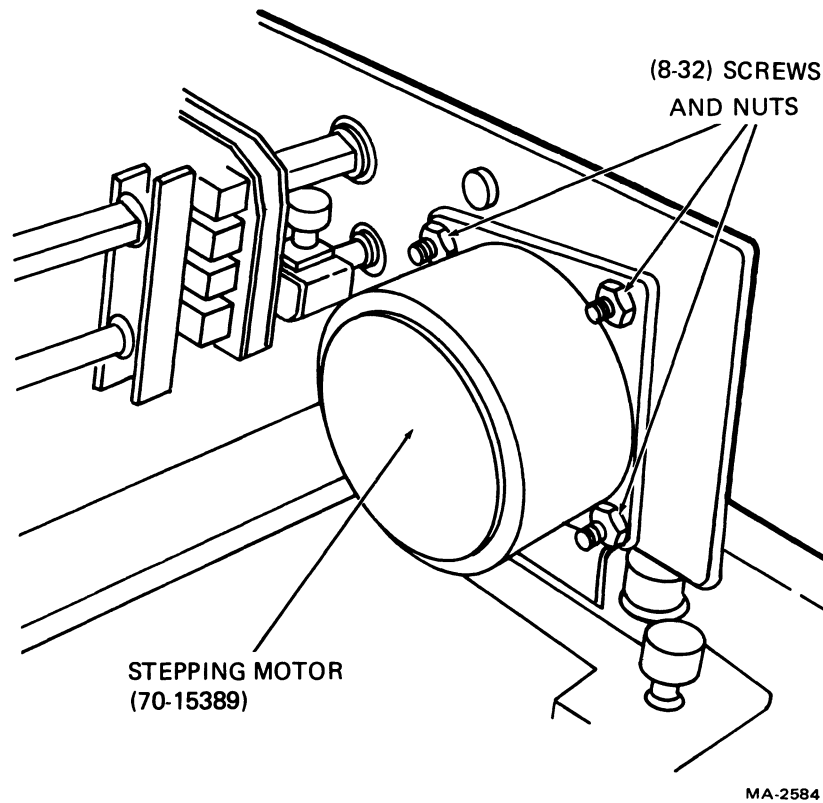

Figure 6-19 Stepping Motor Mounted on Side Plate

4. Disconnect stepping motor from connector J3 on logic/power board (Figure 5-1) and clip necessary cable ties. Disconnect speaker leads.
5. Pull wires up through slot at rear of cabinet.
6. Remove four (8-32) screws, flat washers, lockwashers, and hex nuts that secure stepping motor to left-hand side plate. Set stepping motor aside.

#### 6.17.2 Stepping Motor Assembly Installation

1. Secure new stepping motor to left-hand side plate with four (8-32) screws, flat washers, lockwashers, and hex nuts. **Install lower-left mounting screw first.** The hex nut and lockwashers go on the inside of the left-hand side plate. Allow stepping motor to drop to its lowest point in the elongated slots.
2. Tighten four (8-32) screws to  $18 \pm 2$  in/lb of torque.
3. Reconnect connector to J3 on logic/power board. Secure stepping motor wires with cable ties and thread them under printer mechanism and pushrod and down through slot at rear of cabinet. Connect speaker leads to speaker.
4. Close rear access door.
5. Perform idler gear assembly installation procedure (Paragraph 6.16.2).
6. Perform printer housing installation procedure (Paragraph 6.2.2).

## 6.18 RIBBON CHASSIS ASSEMBLY

The following procedure describes the removal and installation of the ribbon chassis assembly. Refer to Figure 6-20 during the procedure.

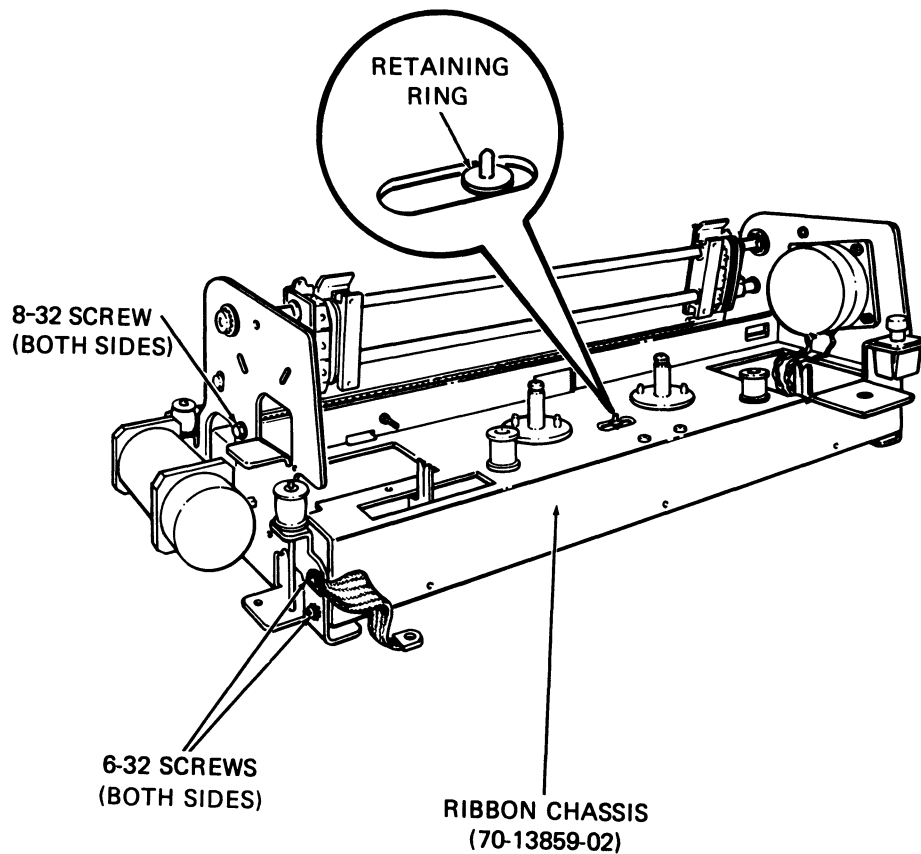

MA-2580

Figure 6-20 Ribbon Chassis Assembly Removal and Installation

### 6.18.1 Ribbon Chassis Assembly Removal

1. Perform printer housing removal procedure (Paragraph 6.2.1).
2. Remove ribbon spools and ribbon.
3. Remove retaining ring that holds pushrod in ribbon chassis.
4. Remove four (6-32) screws, flat washer, and star washers that secure ribbon chassis to right- and left-hand side plates.
5. Remove two (8-32) screws and washers that secure ribbon chassis to right- and left-hand side plates.
6. Remove idler gear (Paragraph 6.16.1).
7. Remove stepping motor (Paragraph 6.17.1) and rest it on printer base.

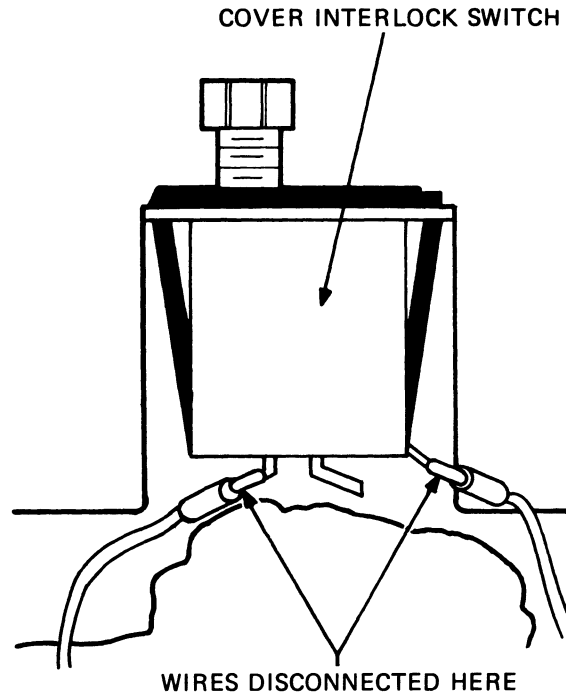

MA-2581

Figure 6-21 Cover Interlock Switch

8. Remove cover interlock switch (Figure 6-21).
9. Remove ribbon chassis and set it aside.

#### 6.18.2 Ribbon Chassis Assembly Installation

1. Secure ribbon chassis to right- and left-hand side plates with two (8-32) screws and lockwashers. Torque the screws to  $18 \pm 2$  in/lb.
2. Replace four (6-32) screws and lockwashers that secure ribbon chassis to right- and left-hand side plates. Torque the screws to  $12 \pm 2$  in/lb.
3. Install stepping motor (Paragraph 6.17.2).
4. Install idler gear (Paragraph 6.16.2).
5. Line up hole in ribbon chassis with pushrod, and replace retaining ring that holds pushrod in place.
6. Install cover interlock switch.
7. Install ribbon spools and ribbon.
8. Install printer housing (Paragraph 6.2.2).

## 6.19 RIBBON SPOOL RATCHET WHEELS AND FRICTION DISKS

The following procedure describes the removal and installation of the ribbon spool ratchet wheel(s) and friction disks. The ribbon chassis assembly must be removed first in order to remove the ribbon spool ratchet wheel(s) and friction disks. Refer to Figure 6-22 during the procedure.

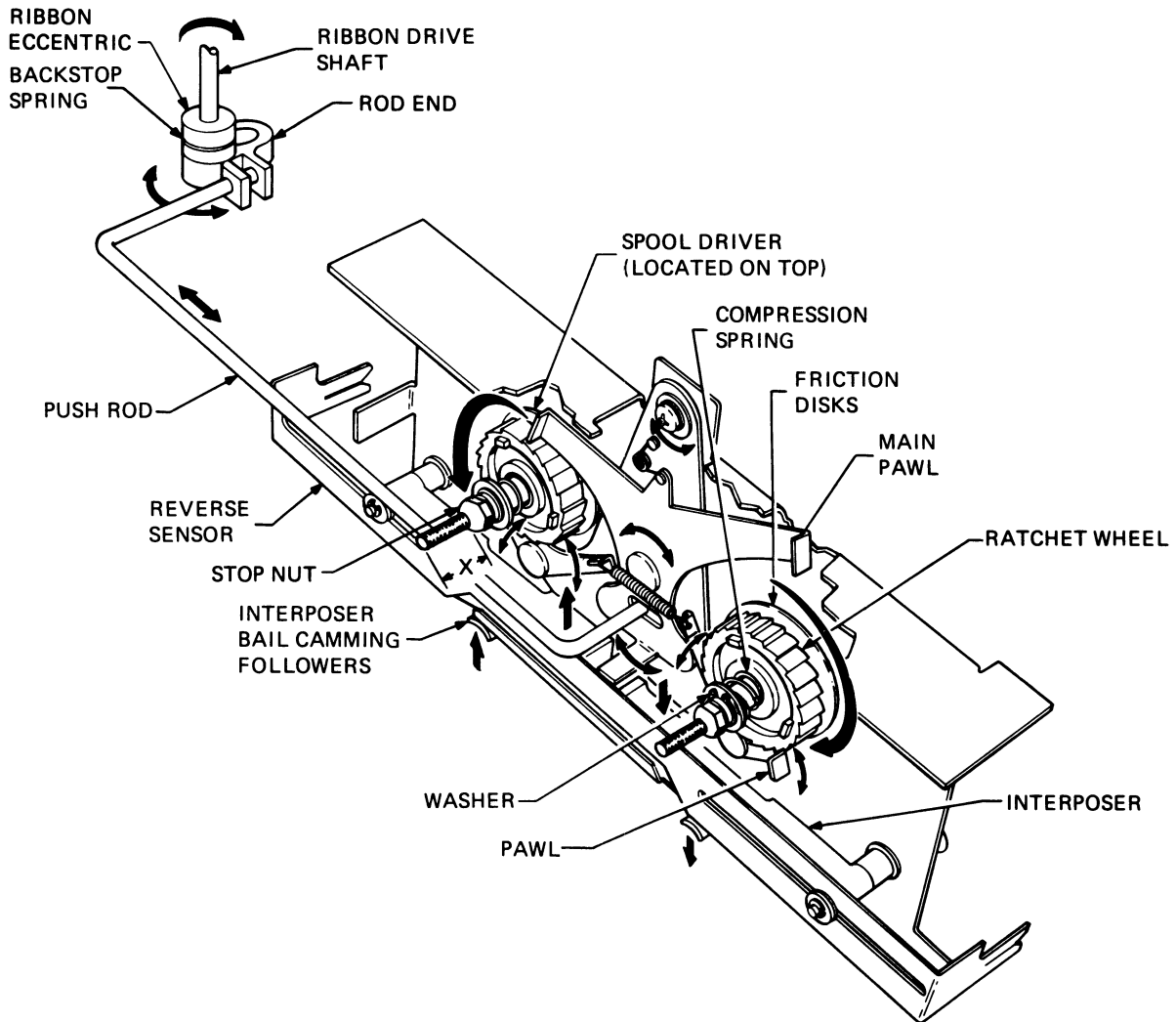

Figure 6-22 Ribbon Spool Ratchet Wheel and Friction Disk Replacement

MA-4509

### 6.19.1 Ribbon Spool Ratchet Wheel(s) and Friction Disk Removal

1. Perform ribbon chassis assembly removal procedure (Paragraph 6.18.1).
2. Measure distance (X) from stop nut to end of screw.
3. Remove stop nut.

4. Remove washers, compression spring, ratchet wheel, spool driver, and screw being careful to note the order in which parts are removed. (See Illustrated Parts Breakdown for an exploded view.)

**NOTE**

**Before removing the ratchet wheel, note the direction of the ratchet wheel teeth. When ratchet wheel is replaced, teeth must be orientated in the same direction.**

5. Remove four old friction disks from ratchet wheel, spool driver, and ribbon chassis. Clean each mounting surface.
6. Remove protective paper from four new friction disks and apply one each to spool driver, ratchet wheel, and to each side of the ribbon chassis. Ensure that friction disk is applied to the side of the ratchet wheel that faces the ribbon chassis. Ensure that surfaces are free of oil and moisture.

### **6.19.2 Ribbon Spool Ratchet Wheel(s) and Friction Disk Installation**

1. Replace screw, spool driver, ratchet wheel, compression spring, and washers. Ensure that ratchet wheel teeth point in the proper direction as shown in Figure 6-22.
2. Replace stop nut. Adjust nut to position on screw noted in Step 2 of Paragraph 6.19.1.
3. Check ribbon tension adjustment (Paragraph 7.5). Readjust stop nut if necessary.
4. Perform ribbon chassis assembly installation procedure (Paragraph 6.18.2).

## **6.20 KEYBOARD/NUMERIC PAD ASSEMBLY**

The following procedure describes the removal and installation of the keyboard/numeric pad assembly. Refer to Figure 6-23 during the procedure.

### **6.20.1 Keyboard/Numeric Pad Assembly Removal**

1. Perform printer housing removal procedure (Paragraph 6.2.1).
2. Remove four (8-32) screws that secure keyboard to printer base.
3. To prevent scratching or damaging the keyboard, rest keyboard bezel on a piece of foam or bubble plastic. Turn keyboard bezel upside down and remove four (8-32) screws and washers that secure keyboard/numeric pad bezel.
4. Lift keyboard/numeric pad and disconnect cable connectors as required.

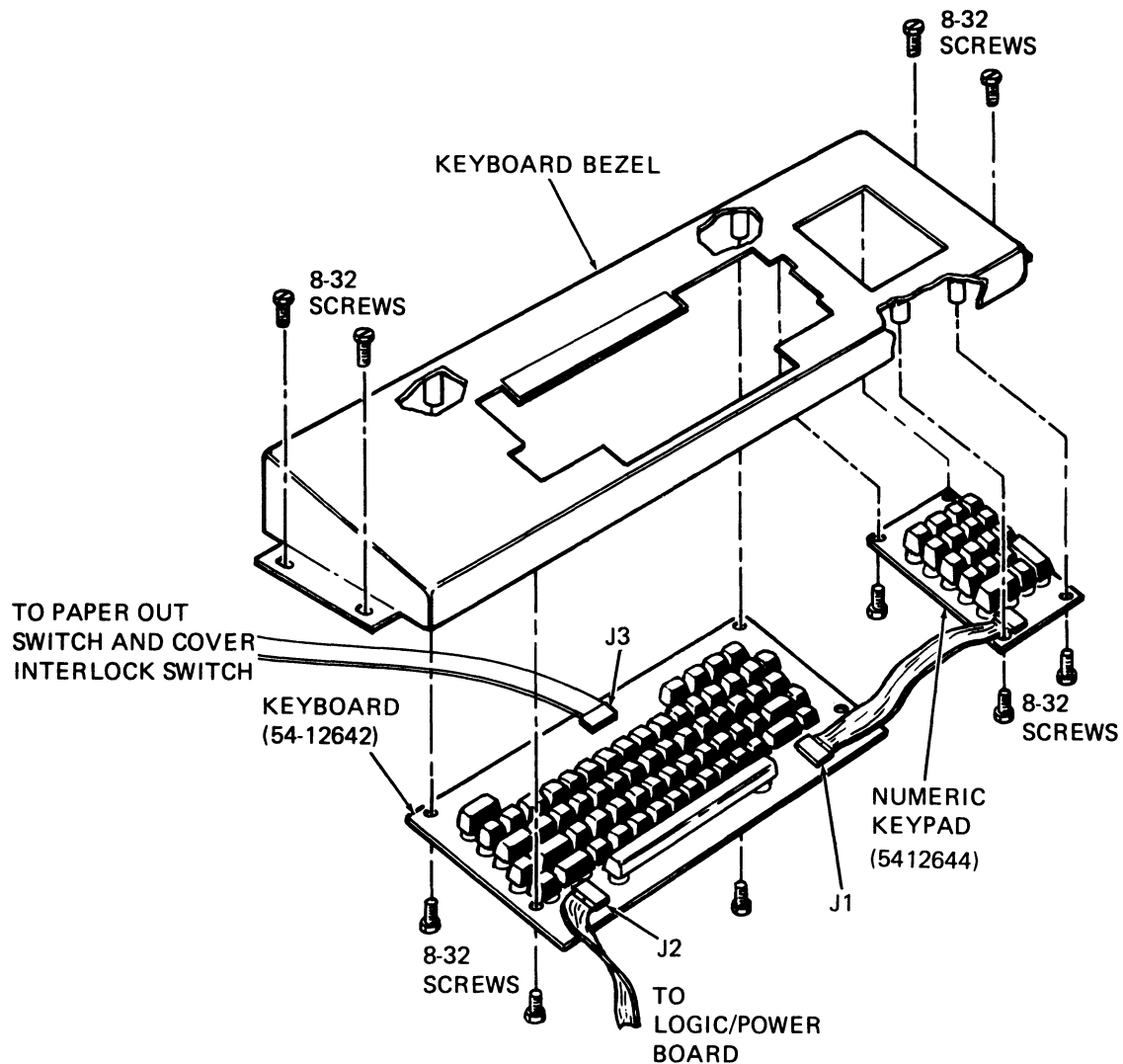

MA-2585A

Figure 6-23 Keyboard/Numeric Pad Removal and Installation

### 6.20.2 Keyboard/Numeric Pad Assembly Installation

1. Reconnect cable connectors to new keyboard/numeric pad. Place pad on bezel and secure with four (8-32) screws.

#### NOTE

The four-pin plug from the paper out switch and cover interlock switch can be inserted into J3 either way.

2. Replace keyboard bezel on cabinet base and secure by pressing in the two sides of bezel to engage the mounting slots.
3. Perform printer housing installation procedure (Paragraph 6.2.2).

### 6.21 POWER SUPPLY ASSEMBLY

The following procedures describe the removal and installation of the power supply. Refer to Figure 6-24 during the procedure.

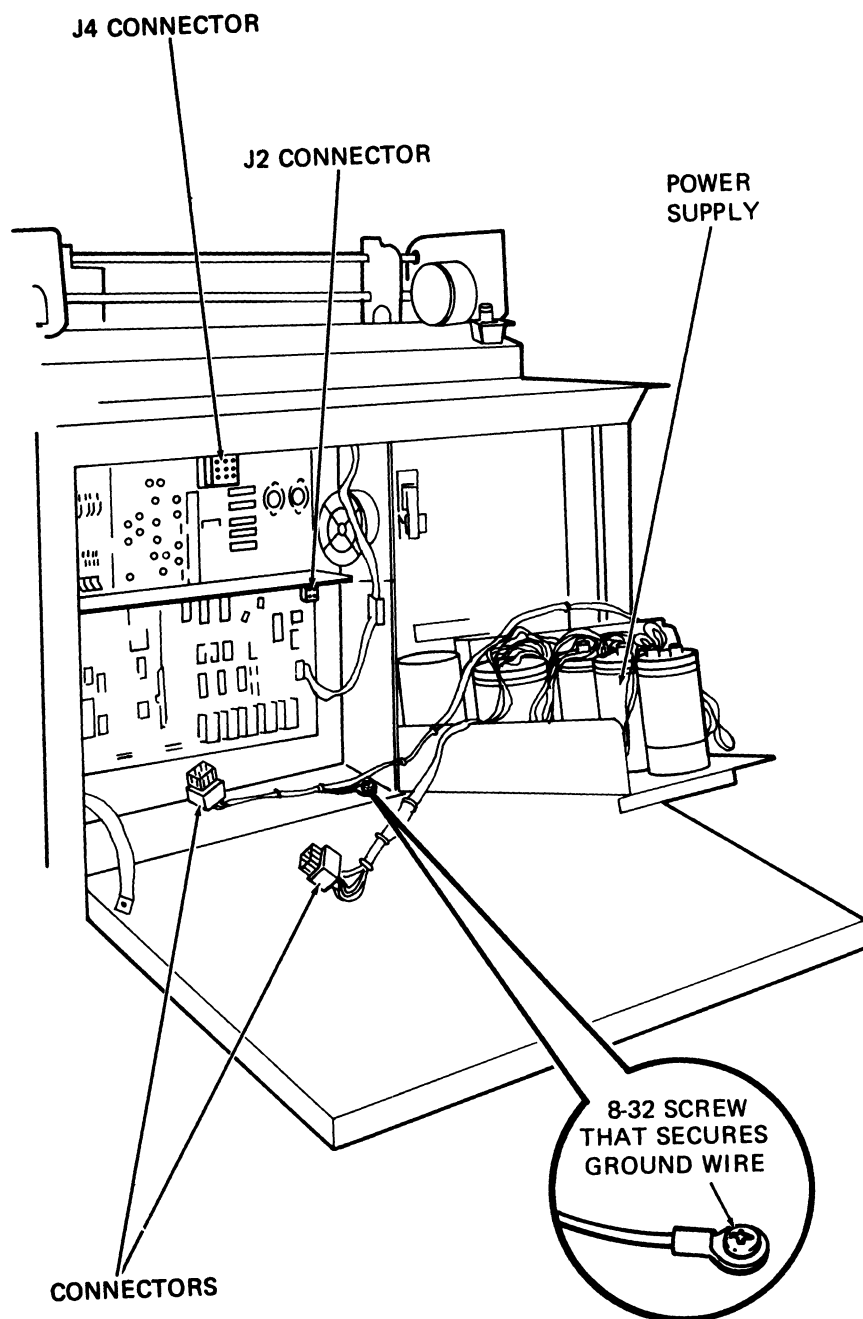

MA-2587

Figure 6-24 Power Supply Assembly Removal and Installation



### **6.21.1 Power Supply Assembly Removal**

1. Remove ac power by unplugging LA120 power cord.
2. Open rear access door on cabinet.
3. Remove ground wire on the side of the power supply by removing (8-32) screw, lockwasher, and flat washer.
4. Disconnect connectors from J2 and J4 on logic/power board.
5. Loosen the two (8-32) screws at top of power supply, which will allow mounting plate to slide down.

#### **CAUTION**

**Placing the full weight of the power supply on the door can damage the door.**

6. Tilt power supply toward door and disconnect Mate-N-Lok™ connector from power entry bracket.
7. Carefully tilt out and remove the power supply.

---

™Mate-N-Lok is a trademark of AMP, Inc.

### 6.21.2 Power Supply Assembly Installation

#### CAUTION

Use care not to damage cables when installing power supply.

1. Connect power supply Mate-N-Lok connector to power entry bracket and slide power supply into position as shown in Figure 6-25.

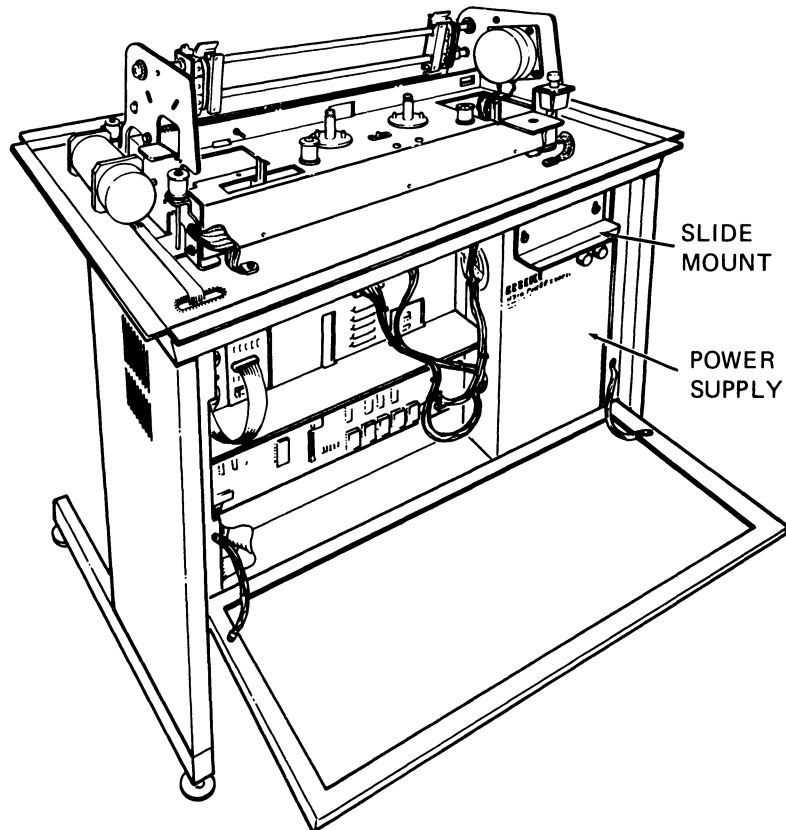

MA-2604

Figure 6-25 Power Supply Assembly in Position

2. Slide mounting plate into slot and tighten two (8-32) screws.
3. Reconnect connectors J2 and J4 to logic/power board.
4. Secure ground wire on the side of the power supply, by using 8-32 screw, lockwasher, and flat washer.
5. Close rear access door on cabinet.
6. Restore power to LA120.

## **6.22 PRINTER MECHANISM ASSEMBLY**

The following procedure describes the removal and installation of the printer mechanism assembly.

### **6.22.1 Printer Mechanism Assembly Removal**

1. Perform printer housing removal procedure (Paragraph 6.2.1).
2. Remove ribbon spools and ribbon.
3. Remove the four (6-32) screws, lockwashers, and flat washers that secure print head to carriage and set head aside (Figure 6-3).
4. Open rear access door.
5. Disconnect connectors from J3, J5, and J7 on logic/power board and clip necessary cable ties (Figure 5-1). Pull disconnected wires up through cabinet base.
6. Remove the two (8-32) screws fastening the two ground wires to cabinet base (Figure 6-26).
7. Remove speaker wires from speaker.
8. Loosen the two (8-32) screws on the power supply, thereby causing mounting plate to drop. Tilt power supply back to gain access to printer mechanism rear mounting screw. It is not necessary to completely remove power supply assembly.
9. Remove the two wires from cover interlock switch (Figures 6-27 and 6-21).
10. Remove the four (10-32) screws and washers that secure printer mechanism to cabinet base (Figure 6-26) using a 5/16 inch nut driver.
11. Carefully tilt printer mechanism up toward back of printer (Figure 6-26) and remove the two leads from the paper out switch (Figure 7-4).
12. Remove the two leads from the speaker and cut the cable ties holding the speaker leads.
13. Carefully remove printer mechanism.

### **6.22.2 Printer Mechanism Assembly Installation**

1. Remove the two ground wires from old printer mechanism and connect them to new printer mechanism.
2. Place new printer mechanism on printer base and connect speaker, paper out, and cover interlock leads. Secure leads as required with cable ties. Secure wire harness to base using cable clamps.
3. Secure printer mechanism to base with four (10-32) screws and washers (Figure 6-26). Make screws finger tight.
4. Thread cables and wires down through slots at rear of cabinet.
5. Secure connectors to J3, J5, and J7 on logic/power board (Figure 5-1).

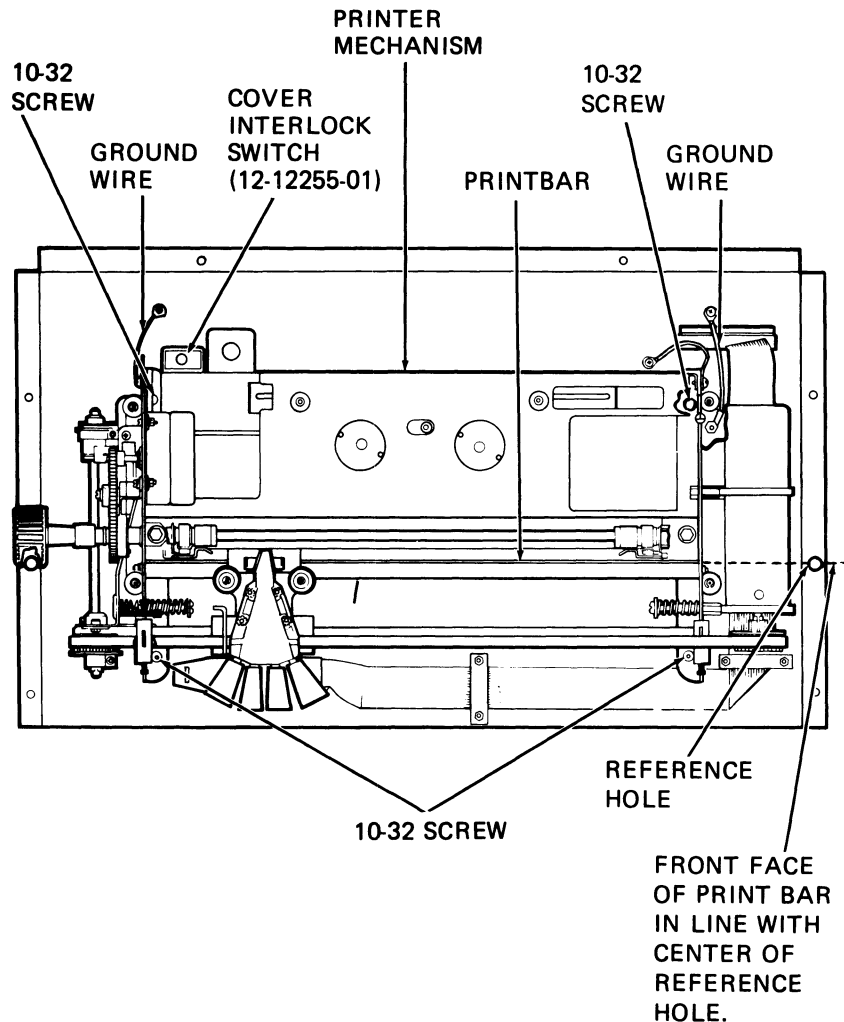

MA-2576

Figure 6-26 Printer Mechanism Assembly Removal and Installation

6. Connect ground wires from printer mechanism to base with 8-32 screws (Figure 6-26).
7. Dress cables and wires inside the cabinet and secure cable harness, as required, to cabinet using cable clamps.
8. Adjust position of printer mechanism (front to back) so that front surface of print bar coincides with centerline of the reference holes in cabinet (Figure 6-27) within 0.030 inch. Tighten the four (10-32) screws to  $5 \pm 1$  in/lb of torque.
9. Perform print head installation procedure (Paragraph 6.3.2).
10. Slide print head assembly across carriage shafts and check to ensure that carriage assembly does not rub and is parallel to bent up flange (Figure 7-3). Loosen and readjust printer mechanism if necessary.

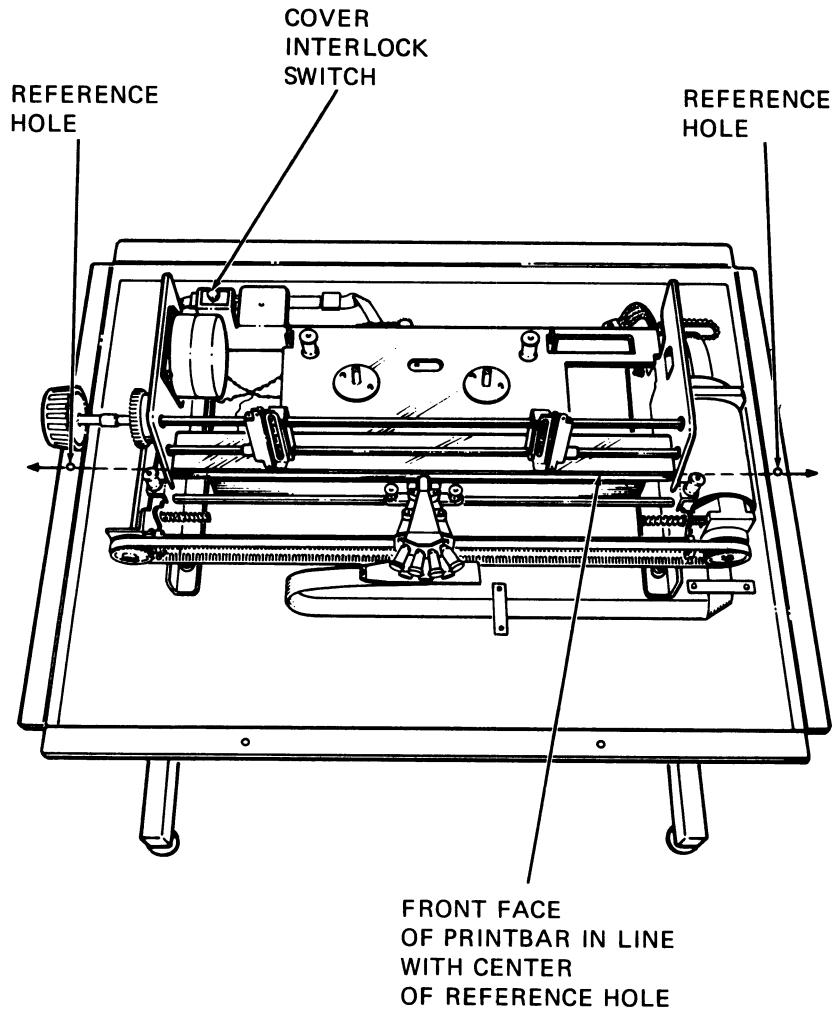

MA-2577

Figure 6-27 Cabinet Reference Holes

11. Carefully slide power supply back into position. Slide mounting plate through slot and tighten the two (8-32) screws.
12. Close rear access door on the cabinet.
13. Replace paper in printer but do not feed it up into tractors. Pull paper up through cabinet and printer mechanism to ensure that there is no drag on the paper. If drag is encountered, perform printer mechanism and paper guide adjustments (Paragraphs 7.2 and 7.3). Remove paper from machine.
14. Perform printer housing installation procedure (Paragraph 6.2.2).

## 6.23 CVT POWER SUPPLY MODULE

The following procedure describes the removal and installation of the CVT power supply module. Refer to Figure 6-28 during the procedure.

### 6.23.1 CVT Power Supply Module Removal

1. Remove ac power by unplugging LA120 power cord.
2. Perform power supply removal procedure (Paragraph 6.21.1).
3. Disconnect cables from J1 and J2 on the CVT power supply module.
4. Remove the three (6-32) screws that secure CVT power supply module to power supply.

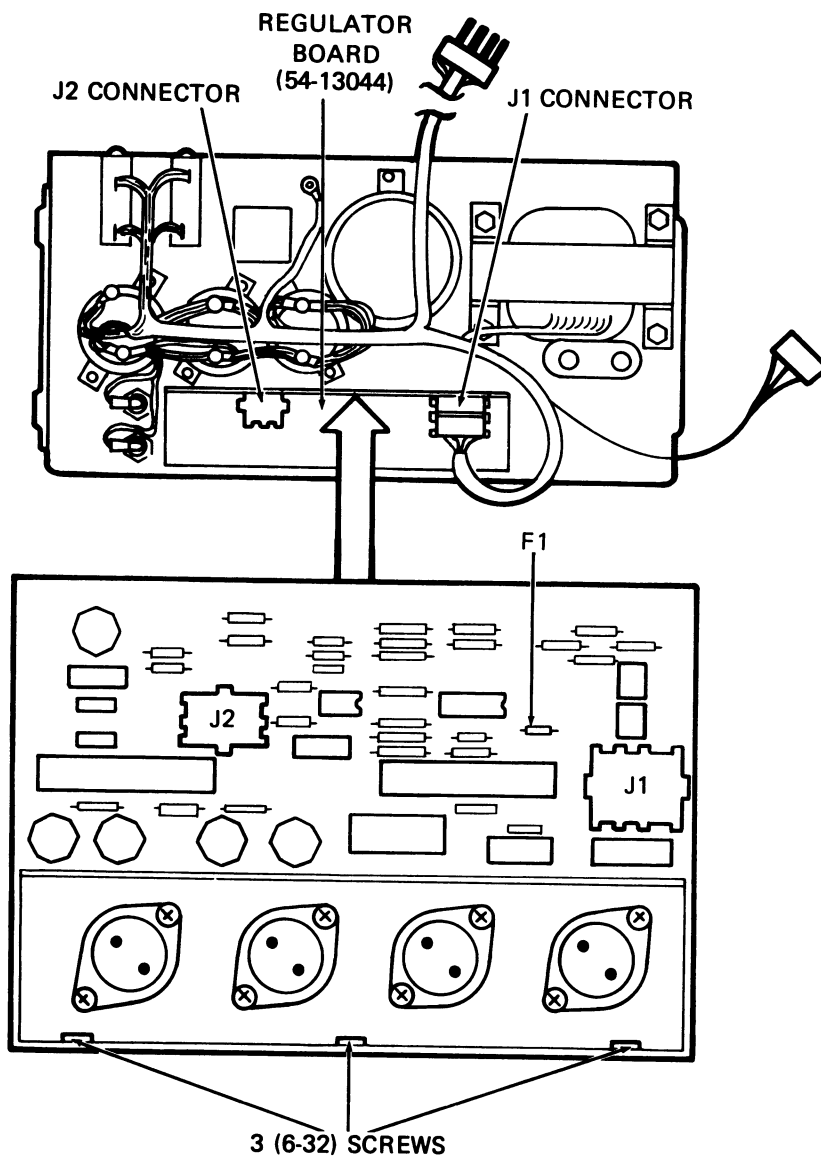

Figure 6-28 CVT Power Supply Module Removal and Installation

### 6.23.2 CVT Power Supply Module Installation

1. Secure new CVT power supply module to power supply using three (6-32) screws.
2. Reattach connectors to J1 and J2 of CVT power supply module.
3. Perform power supply installation procedure (Paragraph 6.21.2).
4. Restore power to LA120.

### 6.24 POWER ENTRY BRACKET ASSEMBLY

The following procedure describes the removal and installation of the power entry bracket assembly. Refer to Figure 6-29 during the procedure.

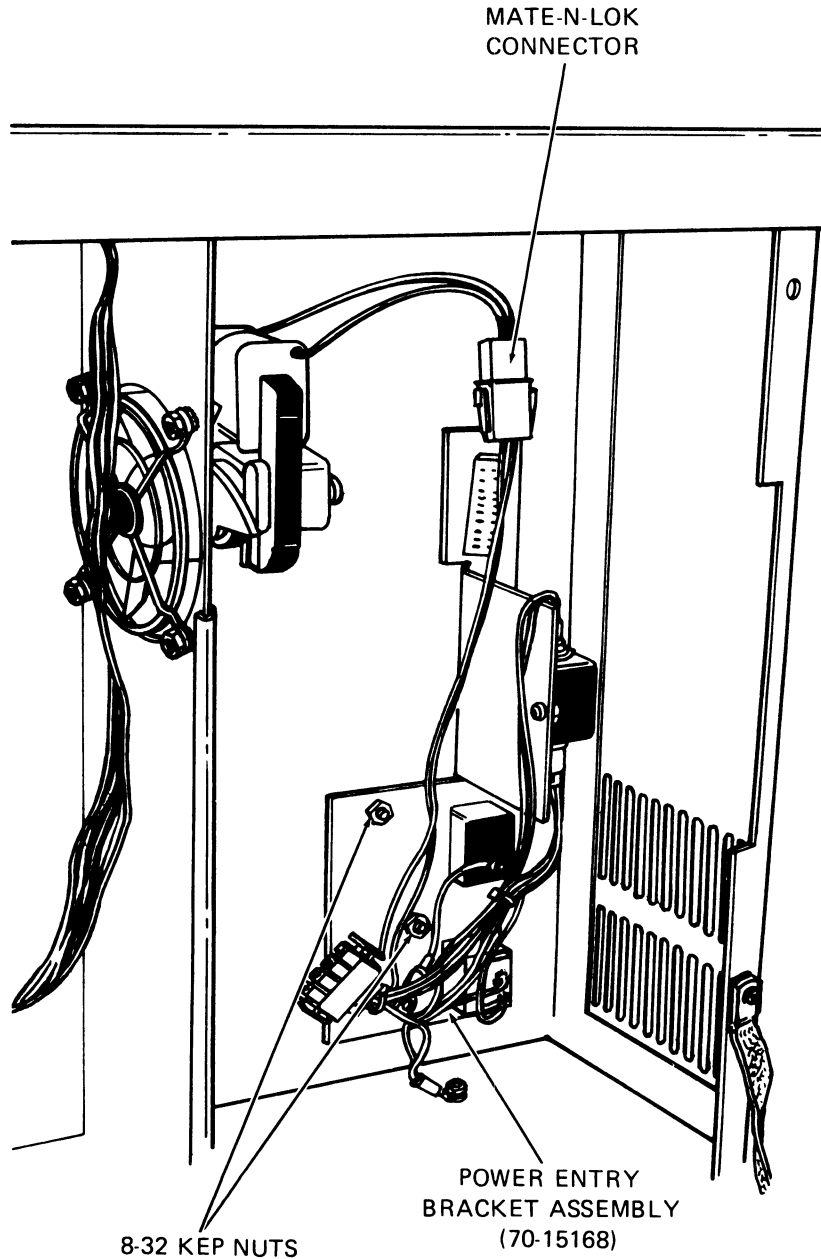

MA-2588

Figure 6-29 Power Entry Bracket Assembly Removal and Installation

### **6.24.1 Power Entry Bracket Assembly Removal**

1. Remove ac power by unplugging LA120 power cord.
2. Unplug ac power cord from front of LA120 unit.
3. Open rear access door on cabinet.
4. Perform power supply removal procedure (Paragraph 6.21.1).
5. Disconnect Mate-N-Lok connector to fan.
6. Remove the three (8-32) nuts and captive washers.
7. Remove the one (8-32) screw, nut, and star washer securing ground wire to cabinet base.
8. Remove power entry bracket assembly.

### **6.24.2 Power Entry Bracket Assembly Installation**

1. Mount power entry bracket assembly using three (8-32) nuts and captive washers.
2. Using the one (8-32) screw, nut, and star washer, secure ground wire to cabinet base; position wire adjacent to cabinet base metal frame.
3. Reconnect Mate-N-Lok connector to fan.
4. Perform power supply installation procedure (Paragraph 6.21.2).
5. Close rear access door on cabinet.
6. Reconnect ac cord.

## **6.25 FAN**

The following procedure describes the removal and installation of the fan. Refer to Figure 6-30 during the procedure.

### **6.25.1 Fan Removal**

1. Remove power by unplugging LA120 power cord.
2. Perform power supply removal procedures (Paragraph 6.21.1).
3. Remove the four (8-32) screws, lockwashers, and flat washers from fan mounting bracket.
4. Disconnect fan Mate-N-Lok and remove fan.

### **6.25.2 Fan Installation**

1. Install fan using the four (8-32) screws, flat washers, and lockwashers. Fan must be installed with coil facing top of cabinet.
2. Connect fan Mate-N-Lok.
3. Place fan wires in cable clamp.
4. Perform power supply installation procedure (Paragraph 6.21.2).



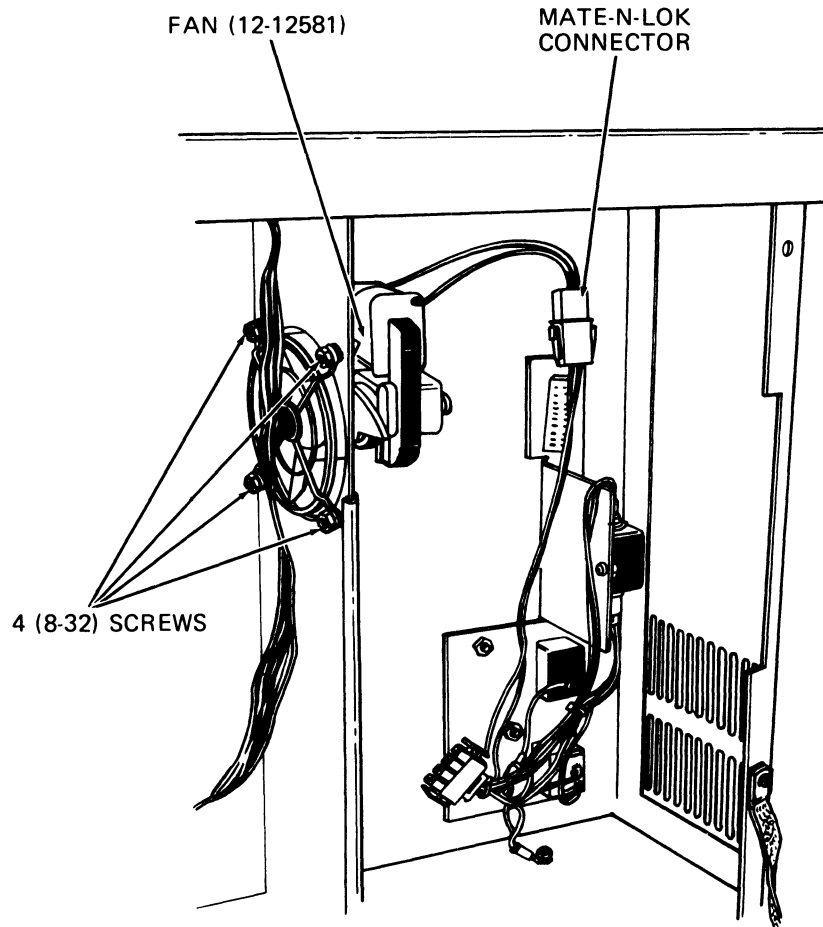

MA-2589

Figure 6-30 Fan Removal and Installation

## 6.26 LOGIC/POWER BOARD

The following procedure describes the removal and installation of the logic board.

### 6.26.1 Logic/Power Board Removal

1. Remove power by unplugging LA120 power cord. Remove printer paper.
2. Open rear access door on cabinet (Figure 6-31).
3. Disconnect all connectors from logic board (Figure 5-1).
4. Remove the seven (6-32) screws that secure the logic board to chassis. Remove by swinging right-hand side of board out first.

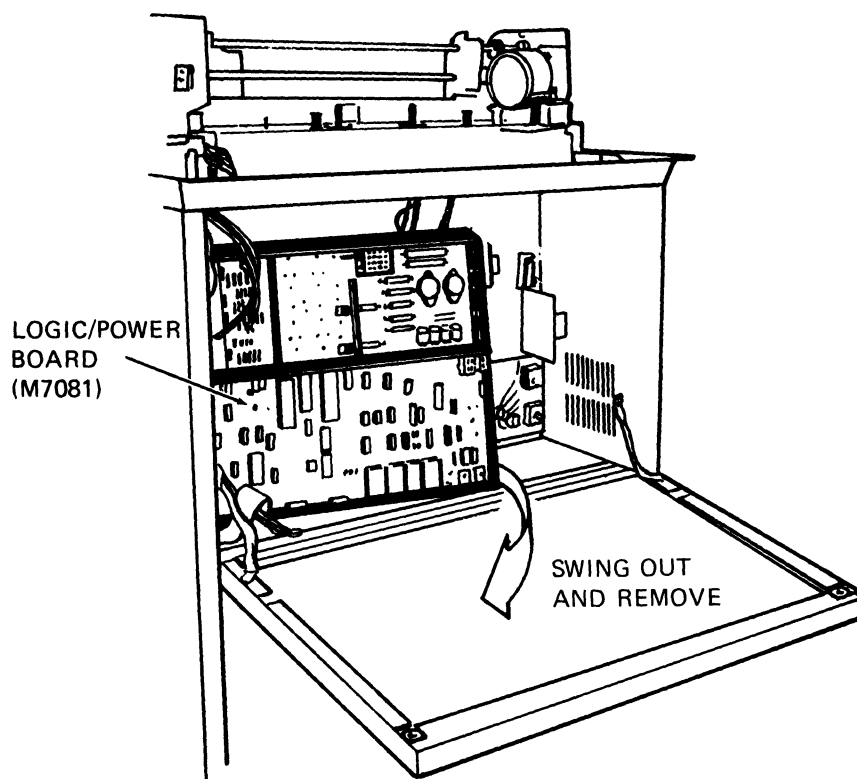

MA-2586

Figure 6-31 Logic/Power Board Removal and Installation

### 6.26.2 Logic/Power Board Installation

1. Place logic board on chassis (left-hand side first). Secure the board with seven (6-32) screws. Tighten to  $8 \pm 1$  in/lb.

#### NOTE

The four (6-32) screws in the heat sink are 0.5 inch long, while the lower three (6-32) screws are 0.25 inch long.

2. Reconnect all connectors to logic/power board (Figure 5-1). Install connector J1 with beveled edge in upper left corner. Install connector J8 with red stripe on left. Install connectors J3 and J7 so they are centered on jack.

#### CAUTION

Be sure to follow the cable orientations in Step 2.

3. Close rear access door on cabinet.
4. Replace printer paper and restore power to LA120.

## **CHAPTER 7**

# **ADJUSTMENT PROCEDURES AND LUBRICATION**

This chapter contains a detailed description of the following LA120 adjustments and information on lubrication.

- Print head adjustment (Paragraph 7.1)
- Printer mechanism adjustment (Paragraph 7.2)
- Paper guide adjustment (Paragraph 7.3)
- Paper out switch adjustment (Paragraph 7.4)
- Ribbon tension adjustment (Paragraph 7.5)
- Ribbon drive assembly adjustment (Paragraph 7.6)
- Idler gear assembly adjustment (Paragraph 7.7)
- Bumper assembly adjustment (Paragraph 7.8)
- Print bar adjustment (Paragraph 7.9)
- Lubrication (Paragraph 7.10)

### **7.1 PRINT HEAD ADJUSTMENT**

The following procedure describes the print head adjustment.

1. Set power switch to off, and remove paper and ribbon.
2. Move print head to middle of print bar (Figure 7-1).
3. Loosen the four (6-32) screws holding print head (Figure 6-3).
4. Set carriage adjustment lever to no. 1 and position print head for contact with print bar.
5. Tighten the four (6-32) screws to  $10 \pm 2$  in/lbs of torque.
6. Replace ribbon and paper.

### **7.2 PRINTER MECHANISM ADJUSTMENT**

1. Set power switch to OFF.
2. Perform printer housing removal procedure (Paragraph 6.2.1).

#### **NOTE**

**Printer mechanism adjustment can be checked by going directly to Step 5.**

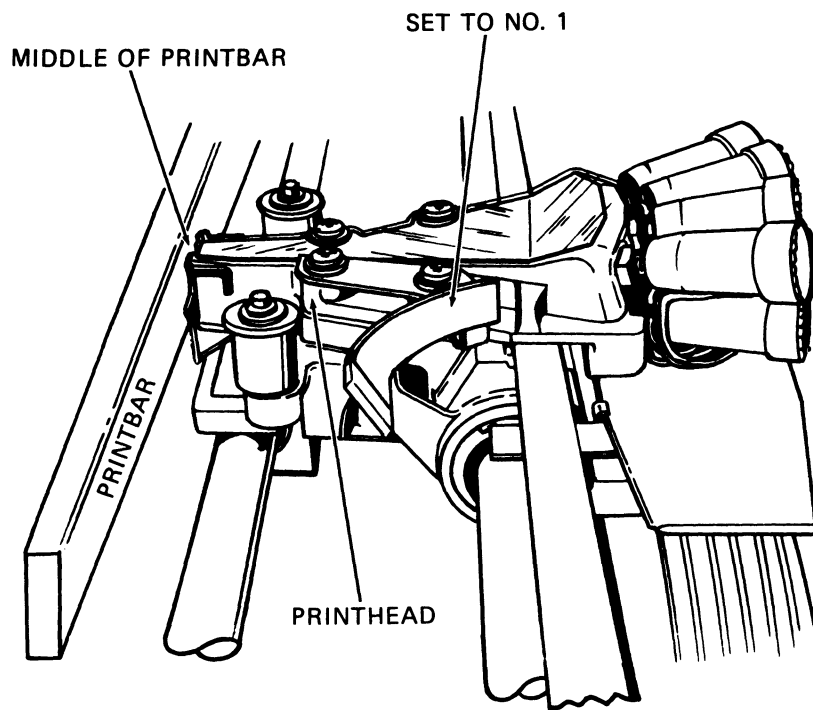

MA-2594

Figure 7-1 Print Head Adjustment

3. Loosen the two (8-32) screws on power supply, thereby causing mounting plate to drop. Tilt power supply back to gain access to printer mechanism rear mounting screw.
4. Loosen the four (10-32) screws that secure printer mechanism to cabinet base (Figure 7-2).
5. Adjust position of printer mechanism (front to back) so that front surface of print bar is in line with centerline of reference holes in cabinet (Figure 7-2) within 0.030 inch. Tighten the four (10-32) screws to  $5 \pm 1$  in/lb of torque.
6. Perform printer housing installation procedures (Paragraph 6.2.2).

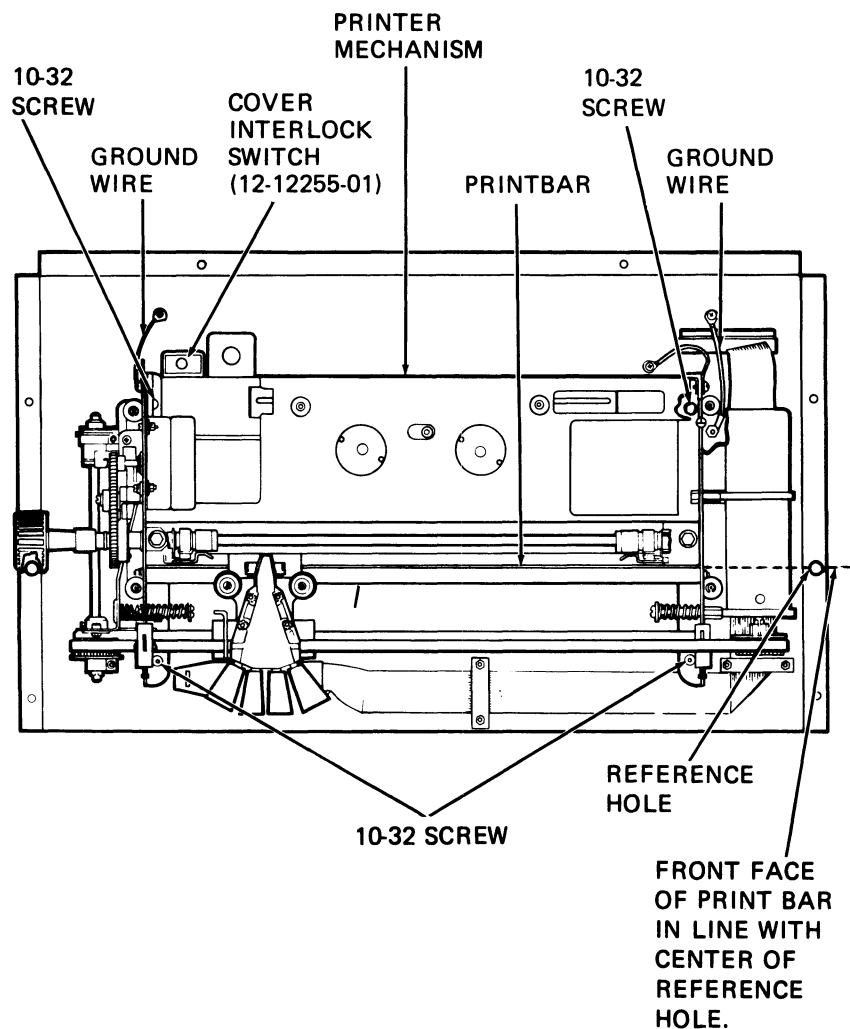

MA-2576

Figure 7-2 Printer Mechanism Alignment

### 7.3 PAPER GUIDE ADJUSTMENT

1. Loosen the three (8-32) screws at bottom of paper guide and adjust for 2.54 to 3.556 mm (0.10 to 0.14 in) gap between paper guide and bent-up flange of base (Figure 7-3).
2. Place paper in machine but do not feed it up into tractors. Pull paper up through cabinet and printer mechanism to ensure that there is no drag on paper.

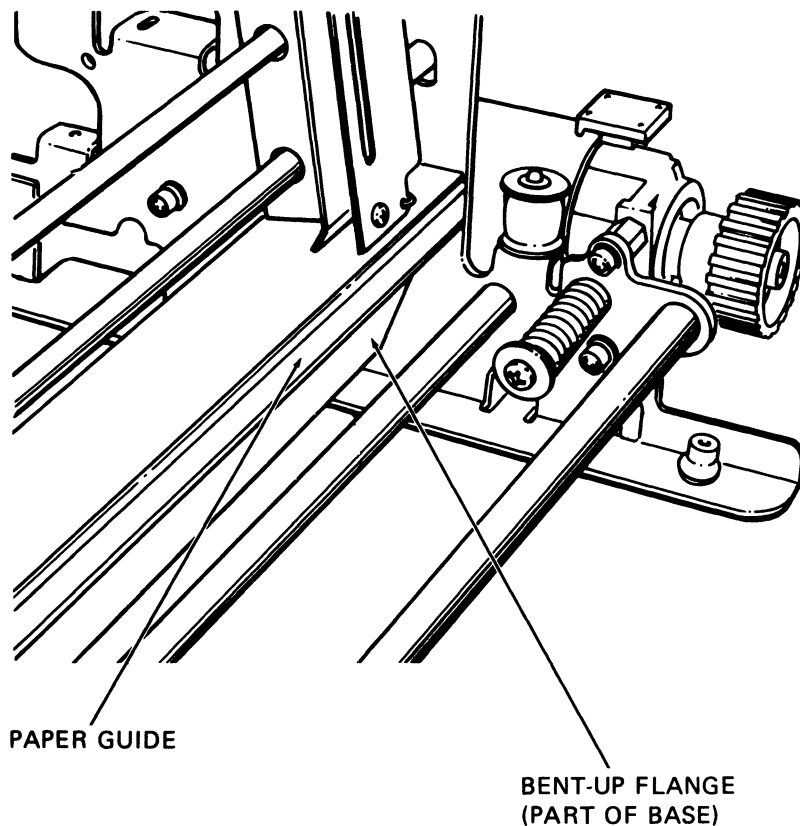

ADJUST FOR 0.10 TO 0.14 INCH GAP  
BETWEEN PAPER GUIDE AND BENT-UP  
FLANGE (FLANGE IS PART OF BASE)

MA-2595

Figure 7-3 Paper Guide Adjustment

## 7.4 PAPER OUT SWITCH ADJUSTMENT

This procedure describes paper out switch adjustment.

1. Set power switch to OFF.
2. Lift up and remove printer cover. Make sure there is paper in LA120.
3. Loosen the two (4-40) screws at paper out switch (Figure 7-4).

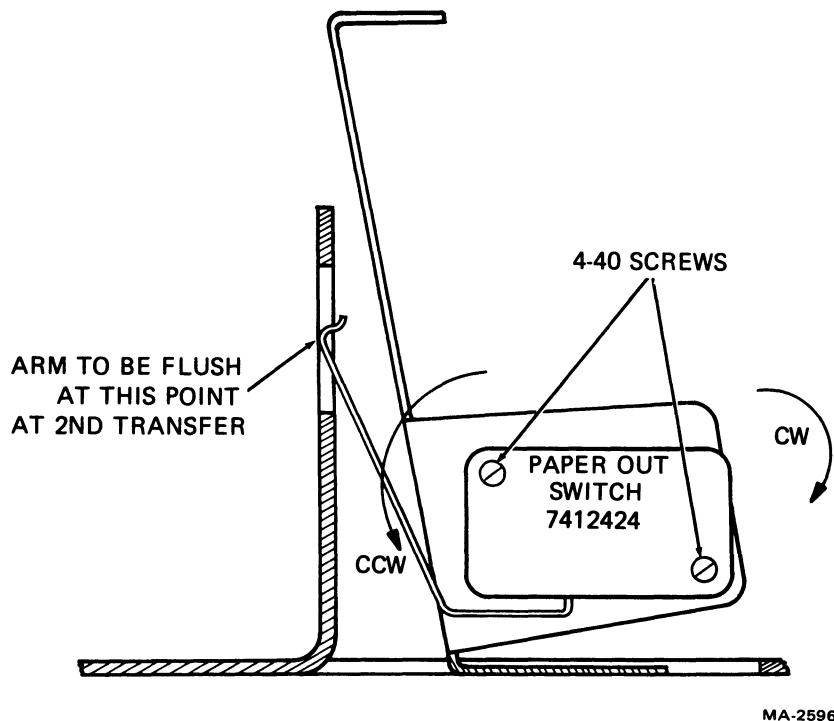

Figure 7-4 Paper Out Switch Adjustment

### NOTE

**If screws cannot be loosened, it may be necessary to reform switch arm to attain the adjustment.**

4. Rotate paper out switch counterclockwise until switch clicks (transfers), then rotate switch clockwise until switch clicks again (transfers back). Tighten the two (4-40) screws to  $5 \pm 1$  in/lb.
5. Replace printer cover.
6. Restore power.

## 7.5 RIBBON TENSION ADJUSTMENT

The following procedure first checks individual spool drag; then, with ribbon installed, a carriage drag test is performed.

1. Set power switch to OFF.
2. Lift up and remove printer cover.
3. Remove ribbon spools and ribbon.
4. Place an empty spool on side not being driven.
5. Wind a small piece of string or ribbon on empty spool. Measure force required to pull string in the direction the ribbon normally takes (Figure 7-5). The measured force should be approximately 0.14 to 0.20 kg (5 to 7 oz).
6. Adjust spool drag by tightening or loosening adjustment screw, while holding nut at base of screw. An 11/32-inch wrench is required to hold nut.
7. Move direction changing guide and check remaining undriven spool for 0.14 to 0.20 kg (5 to 7 oz) tension.

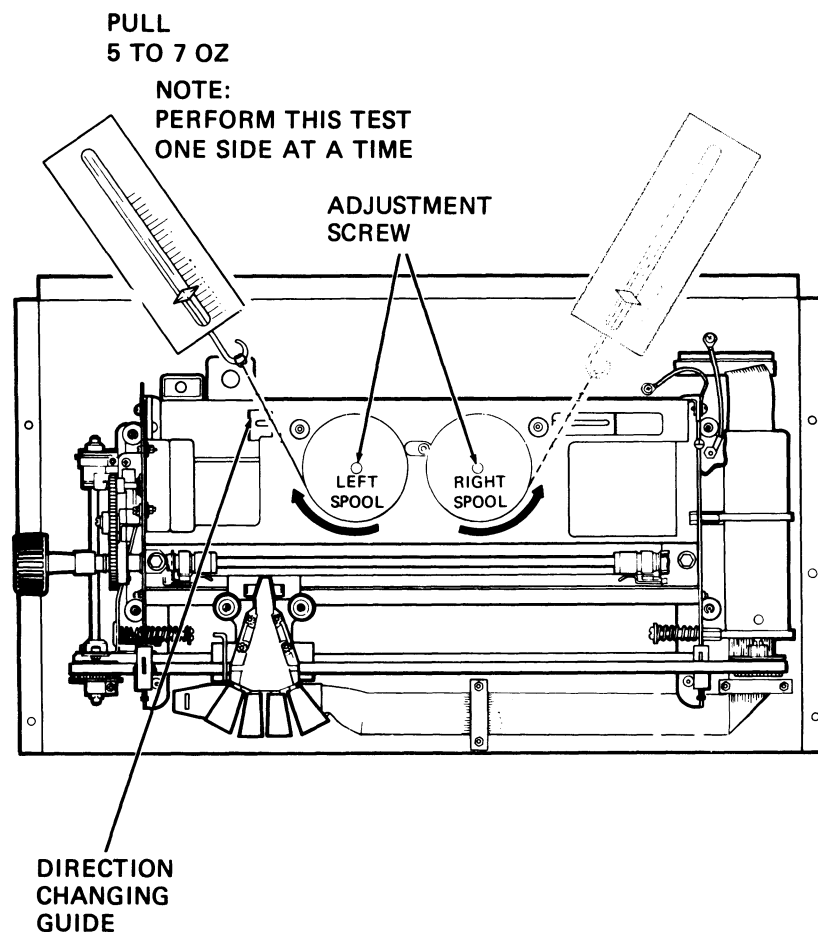

Figure 7-5 Ribbon Spool Tension Adjustment

MA-2597



### NOTE

If a tension gauge is not available, ribbon tension can be approximately adjusted by tightening adjustment screw all the way (until compression spring under ribbon chassis is completely compressed) and then backing off 2-1/2 turns. (Each one-half turn of the screw equals approximately 1 oz of tension.)

8. Install ribbon and spools.
9. With ribbon fully wound on left spool, the ribbon moving right to left across the face of the print head, and the ribbon grommet starting to pull the reverse sensor to the right, a pull test on the carriage from the left to right should indicate a pull of no more than 1.8 kg (4 lb) (Figure 7-6). The ribbon should be moving right to left across the face of the print head when the pull test is made.

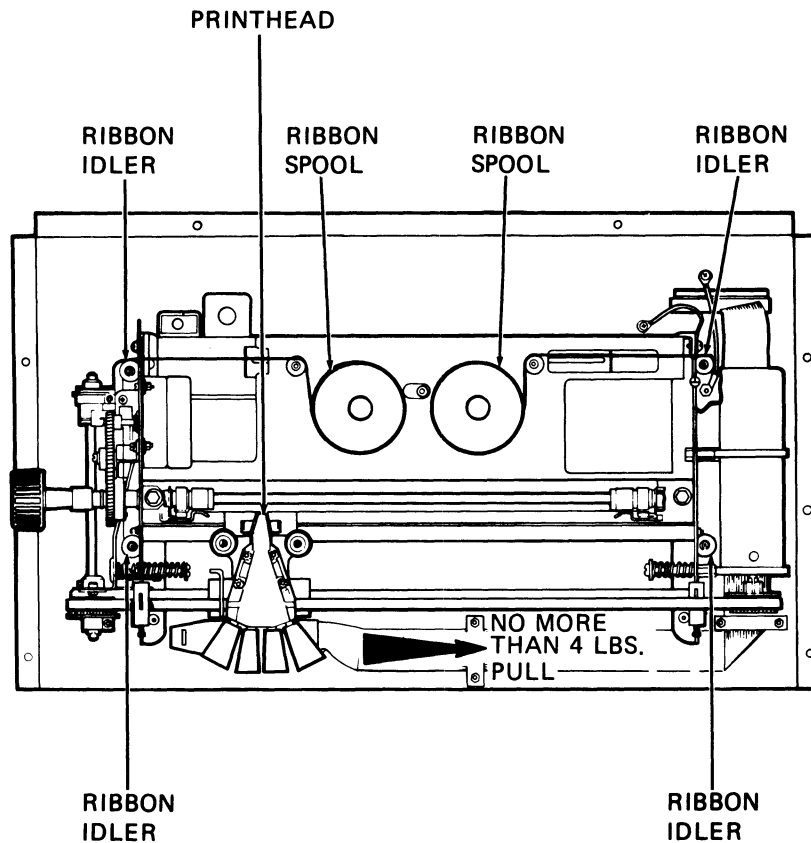

MA-2603

Figure 7-6 Ribbon Threading/Drag Test

Failure to achieve a pull of 1.8 kg (4 lb) maximum could indicate a problem in one of the following areas:

- Ribbon path
- Carriage assembly (misaligned or damaged bearings)
- Printer assembly (damaged end plates)
- Ribbon chassis
- Ribbon drive assembly

10. Reinstall printer cover.

11. Restore power.

## **7.6 RIBBON DRIVE ASSEMBLY ADJUSTMENT**

This procedure describes the ribbon drive assembly adjustment.

1. Set power switch to OFF.
2. Lift up and remove printer cover.
3. Rotate ribbon drive pulley on ribbon drive until clutch eccentric is at its highest point.
4. The ribbon drive pushrod should be at the center of the elongated hole (Figure 7-7). Rotate ribbon drive pulley and check travel of pushrod to either side of the elongated hole. Travel should be equal on both sides of the centerline.
5. To adjust for conditions listed in the previous step, loosen the 8-32 upper pivot screw (Figure 7-7) and move ribbon drive assembly the required amount (Figure 7-8).
6. Tighten the 8-32 screw to  $18 \pm 2$  in/lb, and rotate ribbon drive pulley on ribbon drive until clutch eccentric is at its highest point. Repeat Step 4.
7. Replace printer cover.
8. Restore power to LA120.

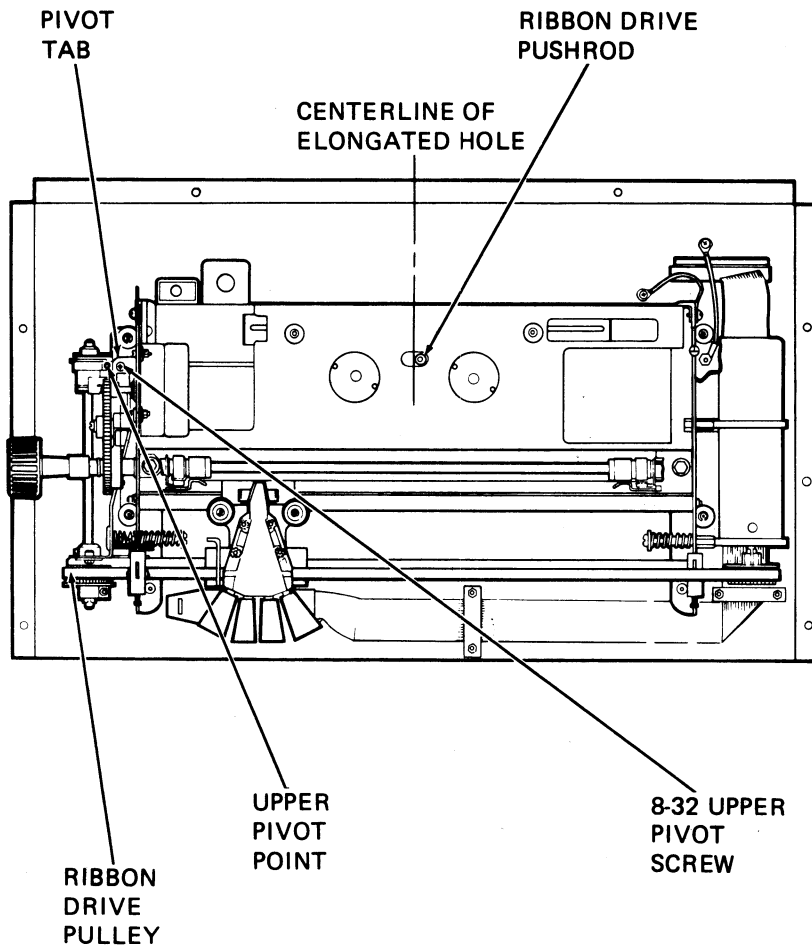

**NOTE:**  
 TRAVEL OF PUSHROD TO BE EQUAL ON BOTH  
 SIDES OF THE ELONGATED HOLE.

MA-2598

Figure 7-7 Ribbon Drive Adjustment

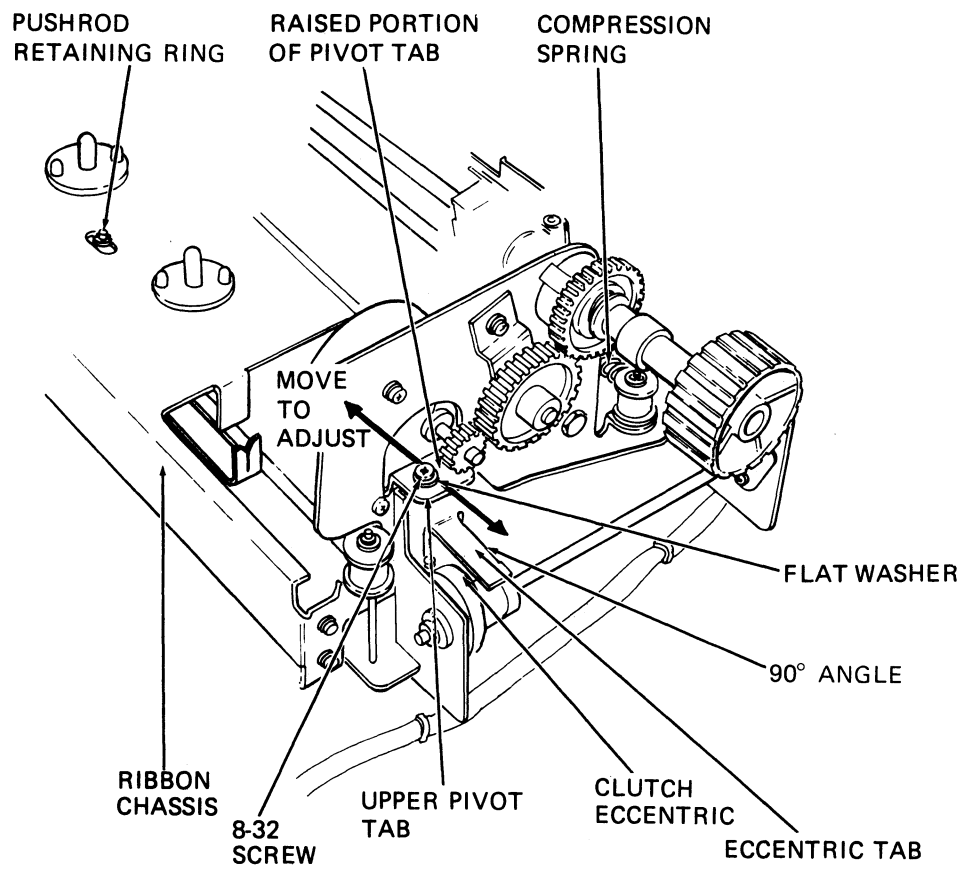

MA-2573

Figure 7-8 Ribbon Drive Assembly

## 7.7 IDLER GEAR ASSEMBLY ADJUSTMENT

This procedure adjusts the idler gear assembly for the correct amount of backlash.

1. Set power switch to OFF.
2. Perform printer housing removal procedure (Paragraph 6.2.1).

### NOTE

**Idler gear backlash can be checked by going directly to Step 4.**

3. To adjust backlash loosen the two (8-32) screws securing idler gear assembly to side plate (Figure 7-9).

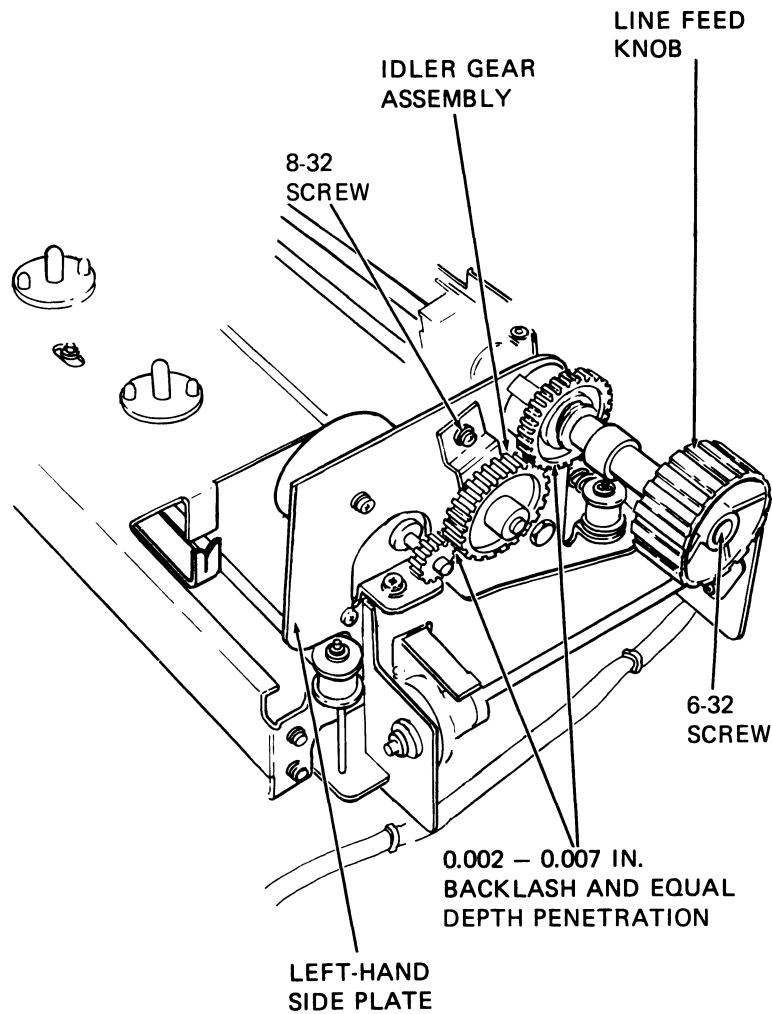

MA-2599

Figure 7-9 Idler Gear Assembly

4. With idler gear in mesh with stepping motor gear and tractor drive gear, adjust idler gear to achieve equal depth penetration and a backlash\* of 0.0508 to 0.01778 mm (0.002 to 0.007 in) between each pair of gears (Figure 7-9). The idler gear should be free to slide in and out. Rotate gears to check backlash in several places.
5. Tighten the two (8-32) screws to  $18 \pm 2$  in/lb of torque.
6. Perform printer housing installation procedure (Paragraph 6.2.2).
7. Restore power to LA120.

### 7.8 BUMPER ASSEMBLY ADJUSTMENT

Tighten the screws (Figure 7-10) until the top of the washers are 43.69 mm (1.72 in) from the right and left side plates. Center the spring around the screw.

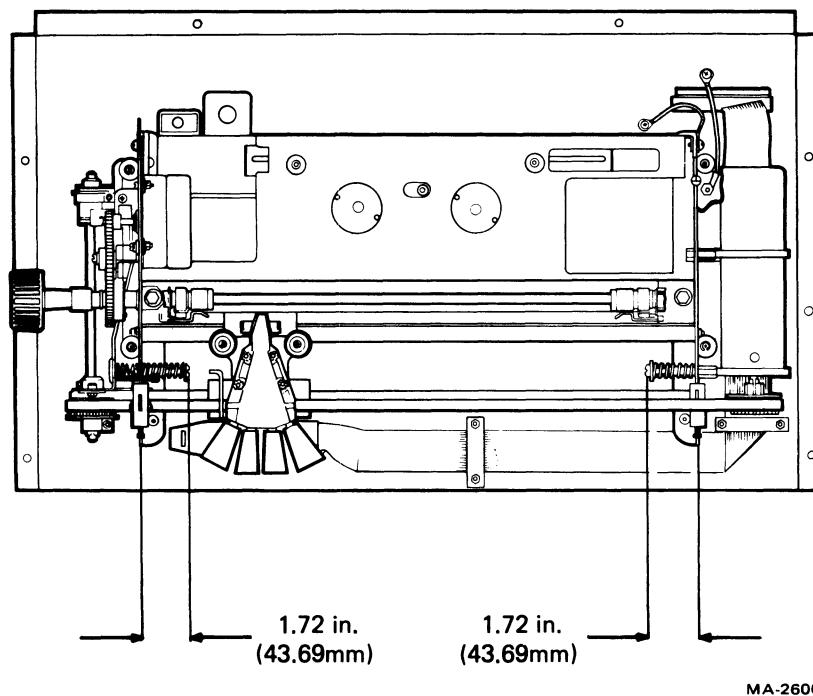

Figure 7-10 Bumper Assembly Adjustment

\*Backlash is the amount a gear turns prior to turning the gear it meshes with.

## 7.9 PRINT BAR ADJUSTMENT

1. Remove power from LA120.
2. Remove printer housing (Paragraph 6.2.1).
3. Remove ribbon and ribbon spools.
4. Check print bar adjustment by moving print head along carriage shafts, with carriage lever in maximum forward position, and checking distance from print head jewel to print bar. As the print head moves from one end of the carriage shafts to the other, the distance must be  $0.010 \pm 0.002$  in. (See Figure 7-11 for measurement points.) If adjustment is not correct, continue with procedure.
5. Position tractors in center of their travel.
6. Position print head to extreme right of carriage shafts.
7. Loosen the  $7/16$  inch hex-head screws on each end of the print bar.
8. With carriage lever in maximum forward position, use a feeler gauge to set print bar  $0.010$  inch from print head jewel as shown in Figure 7-11. Tighten down the  $7/16$  inch hex-head screw on the right end of the print bar.

### NOTE

**Tightening the screw may move the print bar. In this case, proceed to Step 9 to adjust the left end of the bar and then repeat Step 8.**

9. Move the print head away from the print bar with the carriage lever and position the print head to the extreme left of the carriage shafts. Move the print head to the maximum forward position and perform Step 8 for the left end of the print bar.
10. With carriage lever in maximum forward position, move print head from one end of the carriage shafts to the other, while checking that space between print head jewel and print bar does not vary more than  $\pm 0.002$  inch (i.e., at no point in the travel should a  $0.013$  inch shim fit between the jewel and the print bar, nor should a  $0.007$  inch shim fail to fit between the jewel and the bar). If the space varies more than  $\pm 0.002$  inch, the carriage shafts are probably bent and should be replaced (Paragraphs 6.7 and 6.9).
11. Replace ribbon and ribbon spools.
12. Replace printer housing (Paragraph 6.2.2).

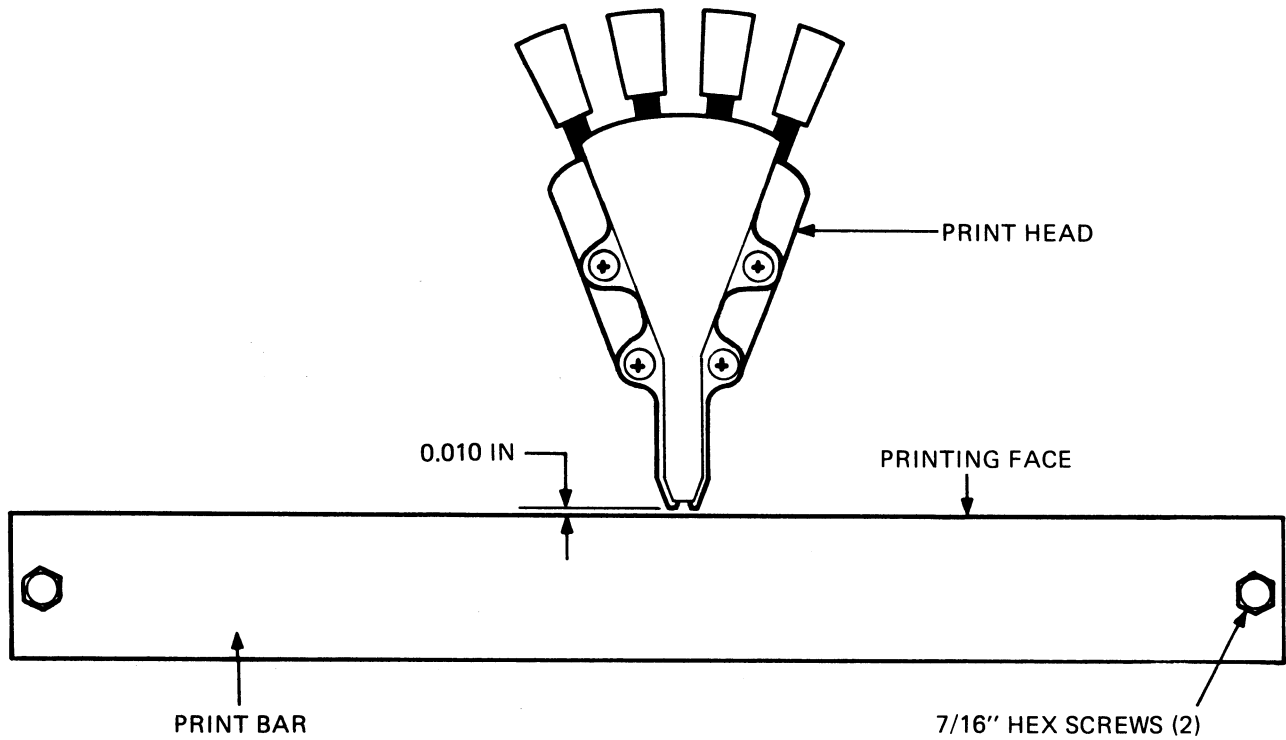

A. TOP VIEW

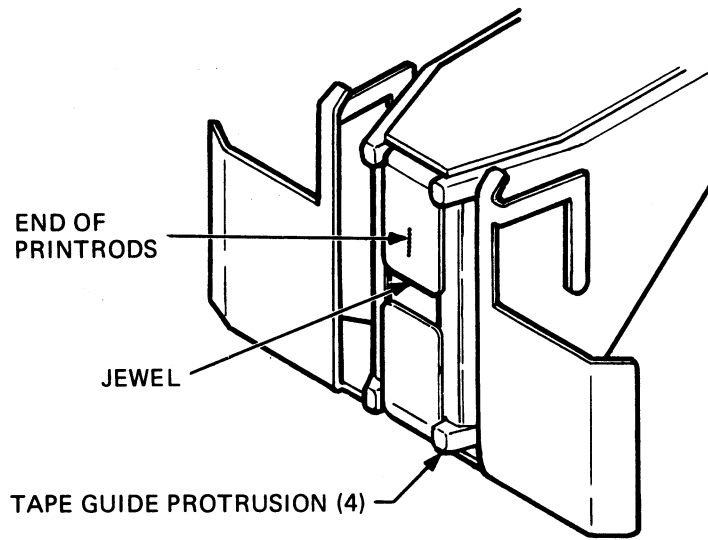

B. FACE OF PRINT HEAD

NOTE: INSERT FEELER GAUGE BETWEEN TAPE GUIDE PROTRUSIONS AND UP AGAINST JEWEL.

MA-4678

Figure 7-11 Print Bar Adjustment



### 7.10 LUBRICATION

The LA120 DECwriter is factory lubricated; however, after an extended period of time, lubrication may be required (oiling should be done infrequently). Table 7-1 lists those areas that may require lubrication.

**Table 7-1 Lubrication Points**

Area	Lubricant	Amount
Carriage Shafts (Figure 7-12)	Digital Part No. 49-00174, or Nye Oil No. 622-00	1 or 2 drops on each carriage shaft
Ribbon Drive Assembly (Figure 7-13)	SAE 30	1 or 2 drops on each of the five places shown in Figure 7-13

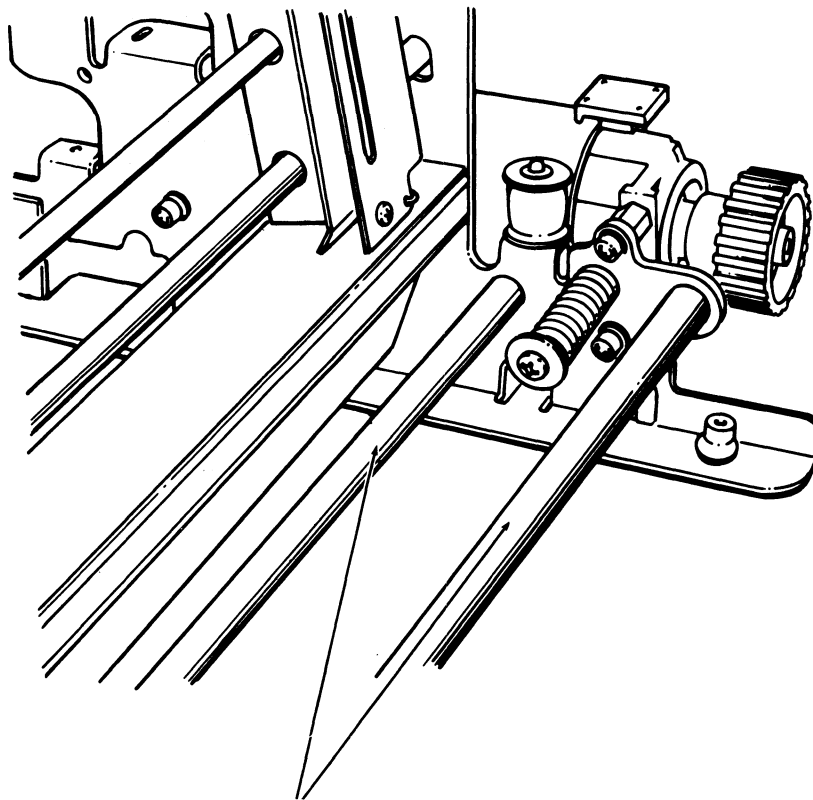

ONE OR TWO DROPS  
OF OIL (DEC PART NO.  
49-001174, OR NYE OIL,  
NO. 622-00)

MA-2601

**Figure 7-12 Carriage Shaft Lubrication**

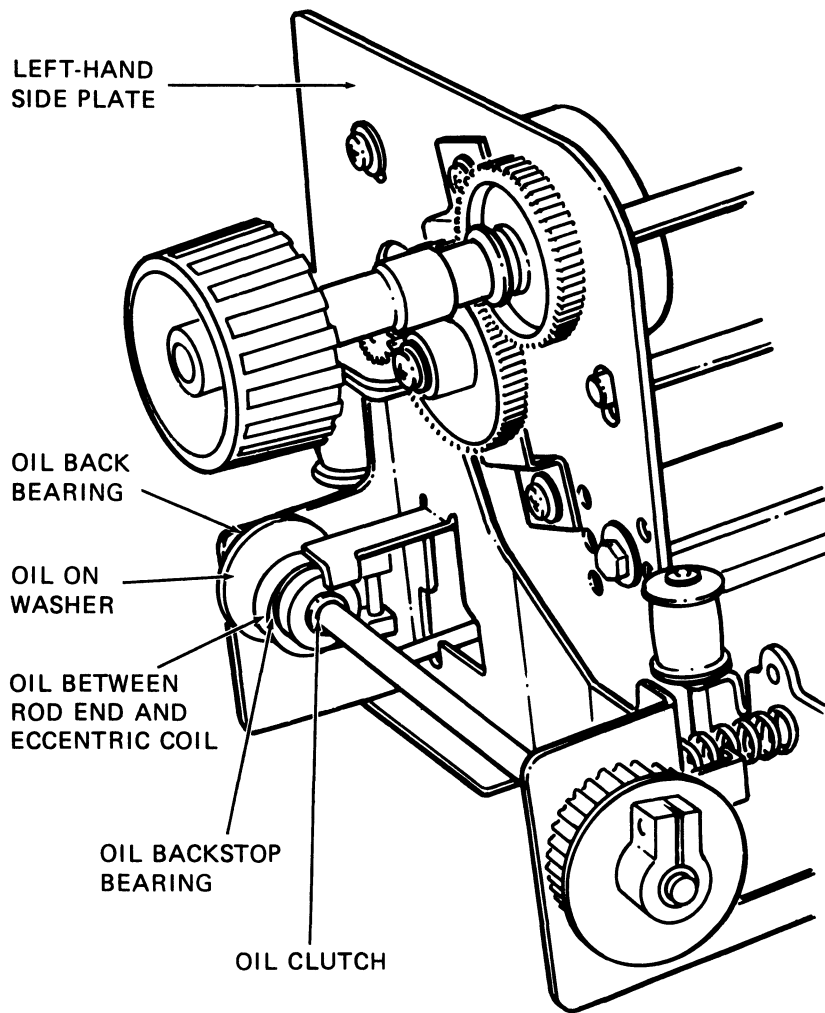

MA-2602

Figure 7-13 Ribbon Drive Assembly Lubrication

## CHAPTER 8

### 20 mA LA12X-AL OPTION

#### 8.1 GENERAL

The 20 mA loop option allows the terminal to communicate directly with the computer up to a distance of 305 m (1000 ft) without the use of a modem.

#### 8.2 INSTALLATION

Table 8-1 lists the items in the 20 mA LA12X-AL option kit.

**Table 8-1 20 mA LA12X-AL Option Kit**

<b>Item No.</b>	<b>Quantity</b>	<b>Description</b>	<b>Part No.</b>
1	1	20 mA External interface cable	BC05F
2	1	20 mA Assembly (logic board)	AD-7016059-0-0
3	1	20 mA Harness assembly	AD-7016186-0-0
4	2	Screw, hex head slotted #8-32, 0.38 long	9009988-08
5	2	Washer, lock, ext. tooth #8	9008072-00

Install the 20 mA option as described in the following steps. Refer to Figure 8-1 during the procedure. Callout reference numbers in the figure are keyed to the item numbers in Table 8-1.

1. Set TRANS switch on 20 mA assembly to NORMAL. If the LA120 must provide current to the transmit line, set switch to ACT.
2. Set REC switch to NORMAL. If LA120 must provide current on the receive line, set the switch to ACT.
3. Lower rear cabinet door on LA120.
4. Disconnect and remove any plug connected to J8 on logic/power board.
5. Slip 20 mA assembly (2) up through hole in floor of cabinet. Secure with two hex-head screws (4) and washers (5).

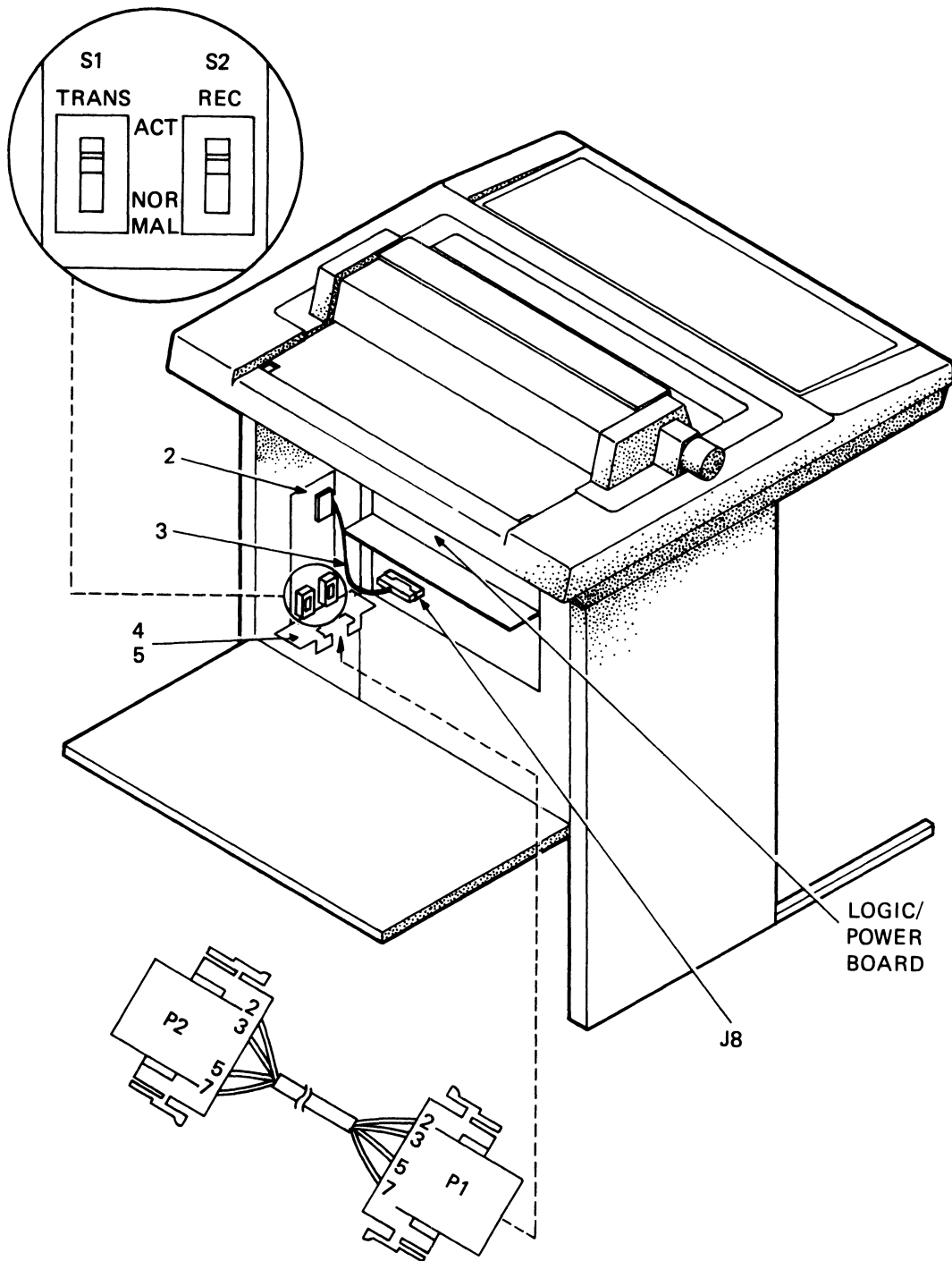

PINNING

FROM	TO
P1-2	P2-3
P1-3	P2-2
P1-5	P2-7
P1-7	P2-5

MA-2320

Figure 8-1 Installation of 20 mA LA12X-AL Option

6. Connect 20 mA harness assembly (3) between jack on 20 mA logic board (2) and J8 on logic/power board.
7. Place LA120 in SET-UP mode. Select and store the following features:
  - Modem = 1 (FDX, no modem)
  - Auto Disconnect = 0 (OFF)
8. Connect P1 of 20 mA external interface cable to bottom connector on 20 mA logic board.

### 8.3 TEST AFTER INSTALLATION

After the LA120 is connected to the system, transmit and receive data to verify the installation.

### 8.4 ELECTRICAL CHARACTERISTICS

#### 8.4.1 Transmitter

	Min	Max
Open circuit voltage	5.0 V	50 V
Voltage drop marking	-	4.0 V
Spacing current	-	2.0 mA
Marking current	20 mA	50 mA

#### 8.4.2 Receiver

	Min	Max
Voltage drop marking	-	2.5 V
Spacing current	-	3.0 mA
Marking current	15 mA	50 mA

#### 8.4.3 Pin Assignments (Figure 8-2)

- 1 - Test Negative
- 2 - Transmit -
- 3 - Receive -
- 5 - Transmit +
- 7 - Receive +
- 8 - Protective ground

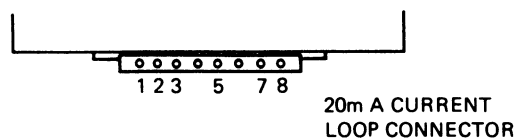

MA3380

Figure 8-2 20 mA Current Loop Connector



## CHAPTER 9 EXPANDED BUFFER OPTION LA12X-DL

Typically a printer receives a series of characters, temporarily stores the characters in a buffer, and then prints the characters one at a time. The LA120 contains a standard 1000 character buffer. The expanded buffer option enables the standard 1000 character buffer to be increased in size to 4000 characters (4K).

An example of the use of this option is an LA120 connected to a video terminal (VT100) whose screen contains 24 lines at 132 characters per line (a total of 3168 characters). The LA120 could receive these characters at 9600 baud, store all 24 lines in the buffer, and then print the characters at the LA120 printing speed of 180 characters per second.

The LA120 buffer control feature\* is not affected by this option. If XON, XOFF, and large buffer is selected, XOFF will still be generated around 600 characters. The only difference is that the buffer is now 4000 characters instead of 1000 characters.

If XON, XOFF, or the equivalent is not used, and the system is operating at high baud rates (for example 2400 baud) for long periods, it may be possible to exceed the 4K buffer capacity.

---

\*See *LA120 User Guide*.

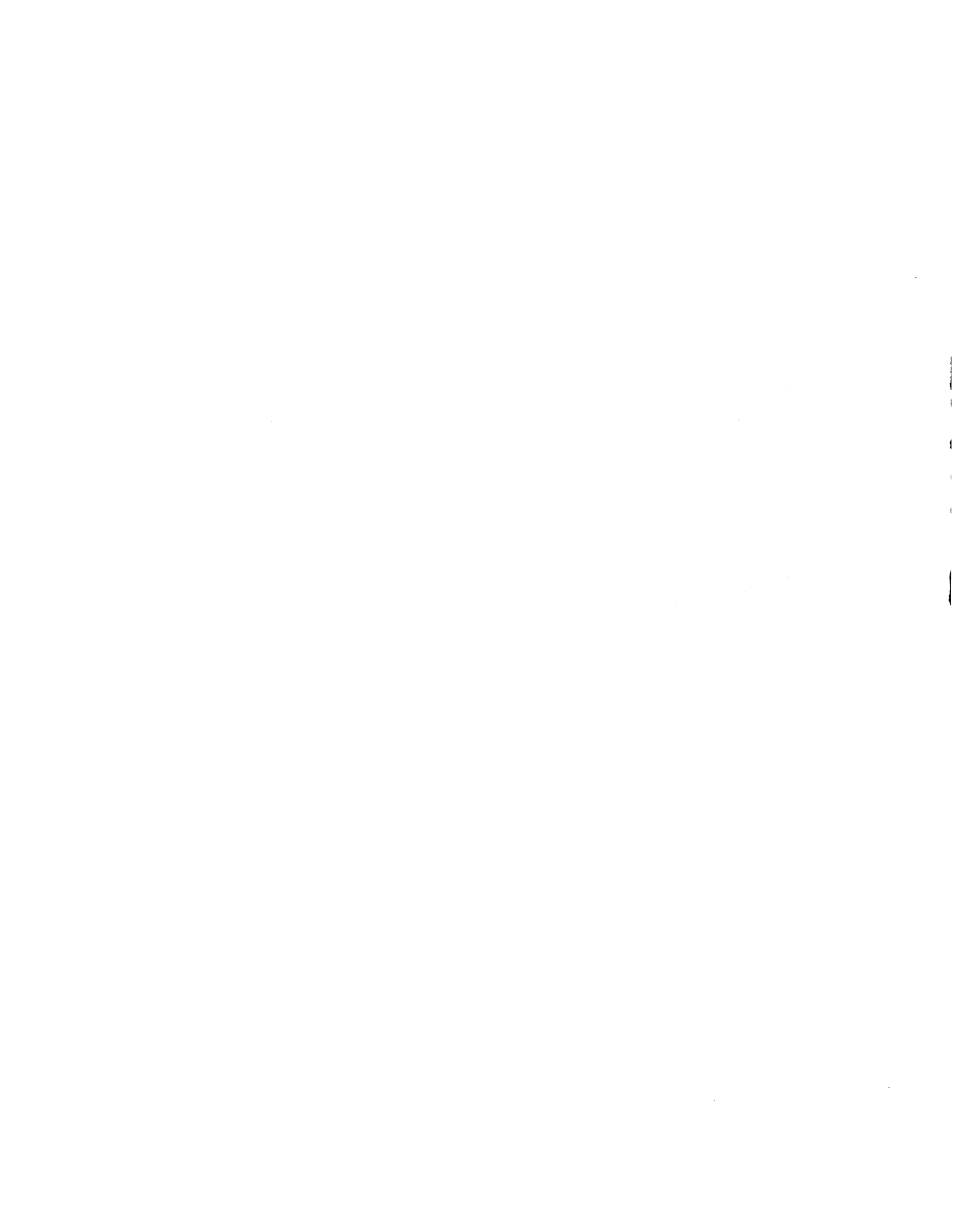



## **CHAPTER 10**

### **LA120-RE**

#### **10.1 INTRODUCTION**

The LA120-RE is a receive only data communications terminal. Its 180 char/s printer uses an impact dot matrix technique (7 × 9), and can handle data up to 9600 baud.

The LA120-RE is identical to the LA120 DECwriter III with one exception; the LA120-RE does not have any type of keyboard.

The SET-UP parameters of this terminal are preset at the factory. Appendix B lists the factory stored settings for each parameter. The legend strip label in Figure 11-5 shows how to interpret the settings.

Two options, the LA12X-HL full keyboard (Figure 10-1) or the LA12X-YL function keypad (Figure 10-2), can be installed on the LA120-RE to allow customers to modify SET-UP parameters.

With the installation of the LA12X-HL option, the LA120-RE becomes a fully functioning LA120 DECwriter III. All features and capabilities of this combination are explained in previous chapters of this manual.

When the LA12X-YL option is installed on the LA120-RE, it remains receive only; however, the SET-UP parameters can now be changed to meet customer requirements. For a description of how to operate the LA12X-YL function keypad option, refer to Chapter 12.

#### **10.2 INSTALLATION**

To install the LA120-RE, perform the procedures given in Chapter 2. Because the LA120-RE has no keyboard, the self-test function cannot be performed. Sending data to the terminal will verify its proper operation.

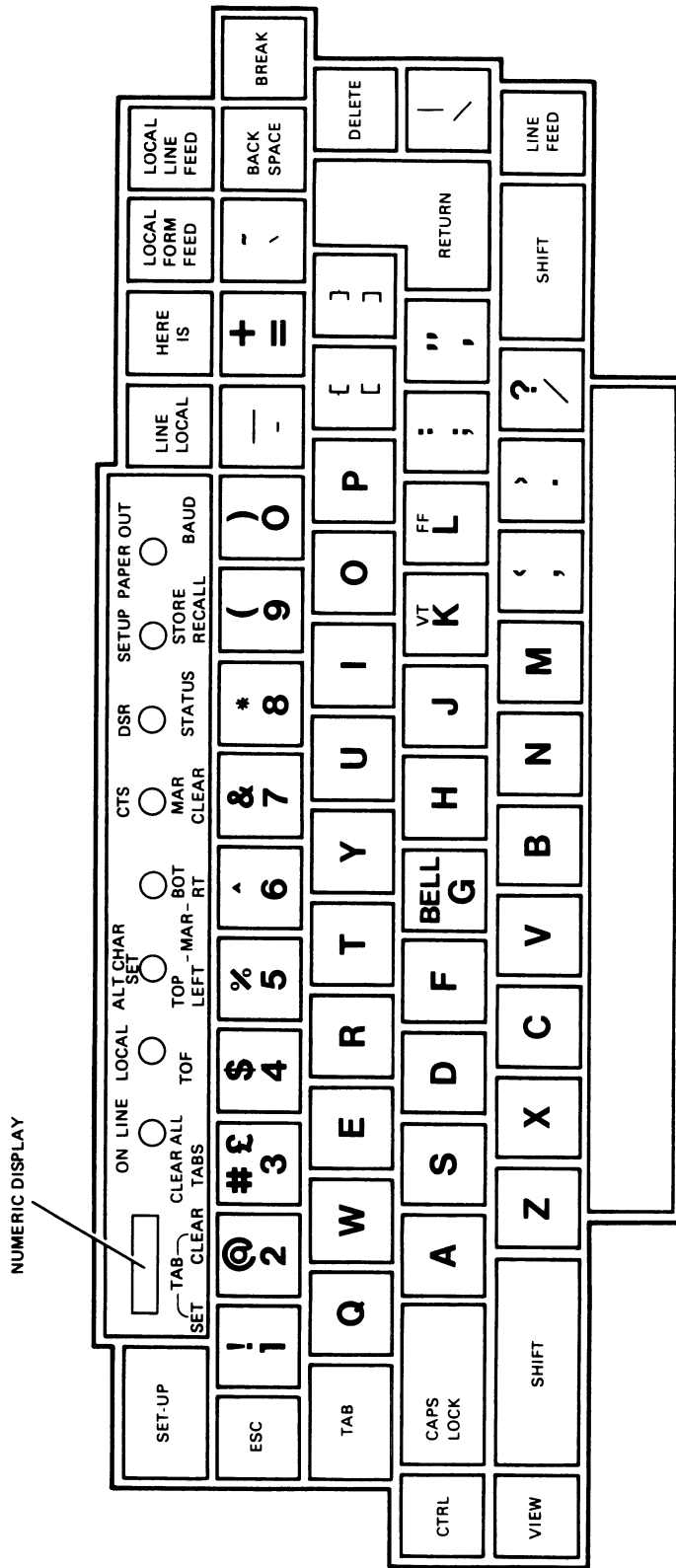

MA-4896

Figure 10-1 LA12X-HL Keyboard

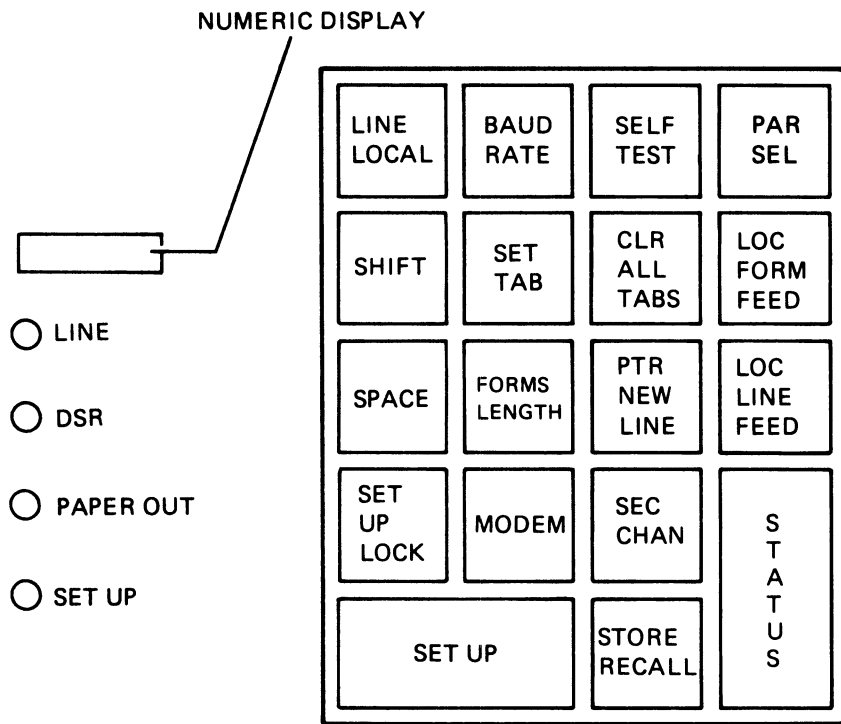

MA-4511

Figure 10-2 LA12X-YL Keypad



## CHAPTER 11 LA12X-HL KEYBOARD OPTION

### 11.1 INTRODUCTION

The LA12X-HL is a full keyboard kit for use with the LA120-RE. When the LA12X-HL is installed, an LA120-RE becomes a complete LA120 DECwriter III terminal.

### 11.2 INSTALLATION

Before installing the LA12X-HL, examine the kit to determine that it contains all the items listed in Table 11-1.

**Table 11-1 LA12X-HL Installation Kit**

Description	Part Number	Quantity
Keyboard/Keycap Assembly	7015763-01	1
Keyboard Cable Assembly	1700120-00	1
Self-Tapping Screw	9010083-00	4
Plastic Cover	1215053-00	2
DECwriter III Label	3615684-00	1
Legend Strip Label	3615683-00	1

To install the LA12X-HL on an LA120-RE perform the following.

1. Remove power by disconnecting ac plug.
2. Remove printer paper and printer cover.
3. Remove six (6-32) self-tapping screws and flat washers that secure printer housing to cabinet base (Figure 11-1) and set them aside. Lift off printer housing and set aside.
4. Snap off cover from keyboard bezel.
5. Snap off keyboard bezel.
6. Open rear access door on cabinet.
7. Disconnect interlock/paper out cable from terminator in J1 on logic board and remove terminator card (Figure 11-2).
8. Route interlock/paper out cable up through cabinet and connect to J3 on keyboard. The four-pin connector can be inserted in either direction.

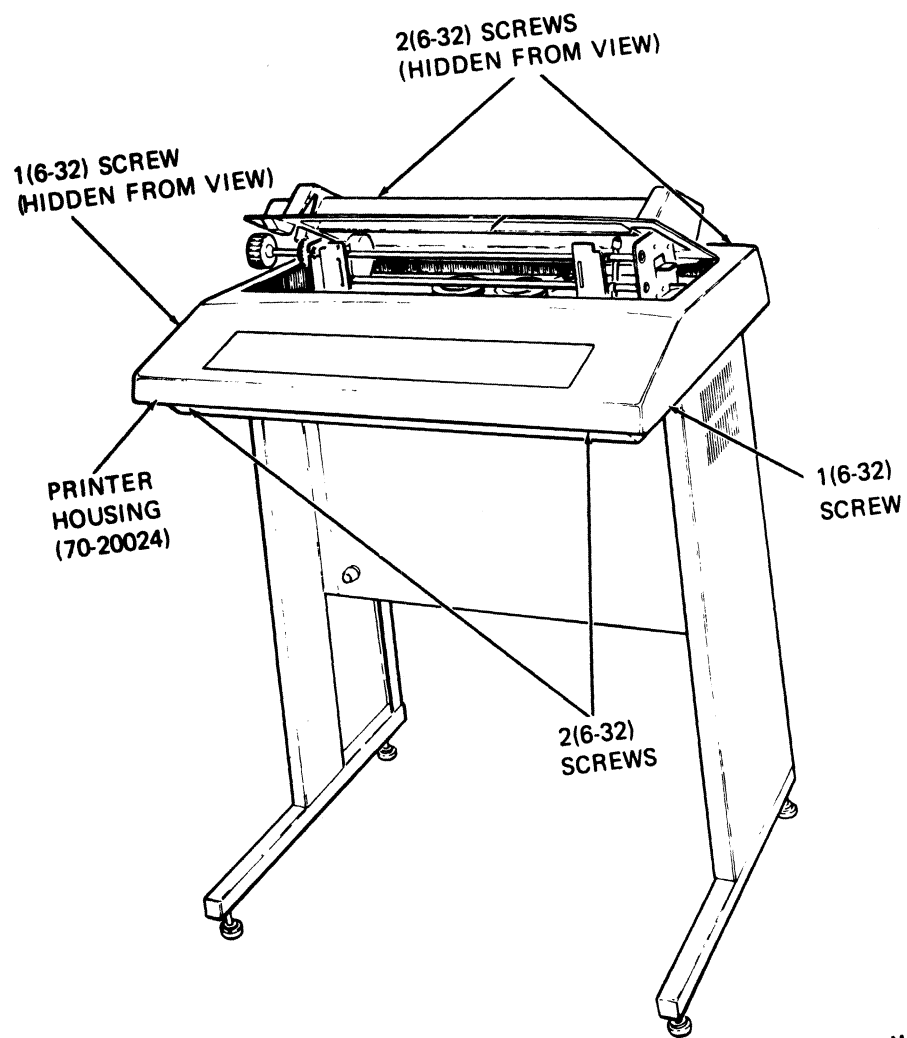

MA-4590

Figure 11-1 Printer Housing Removal and Installation

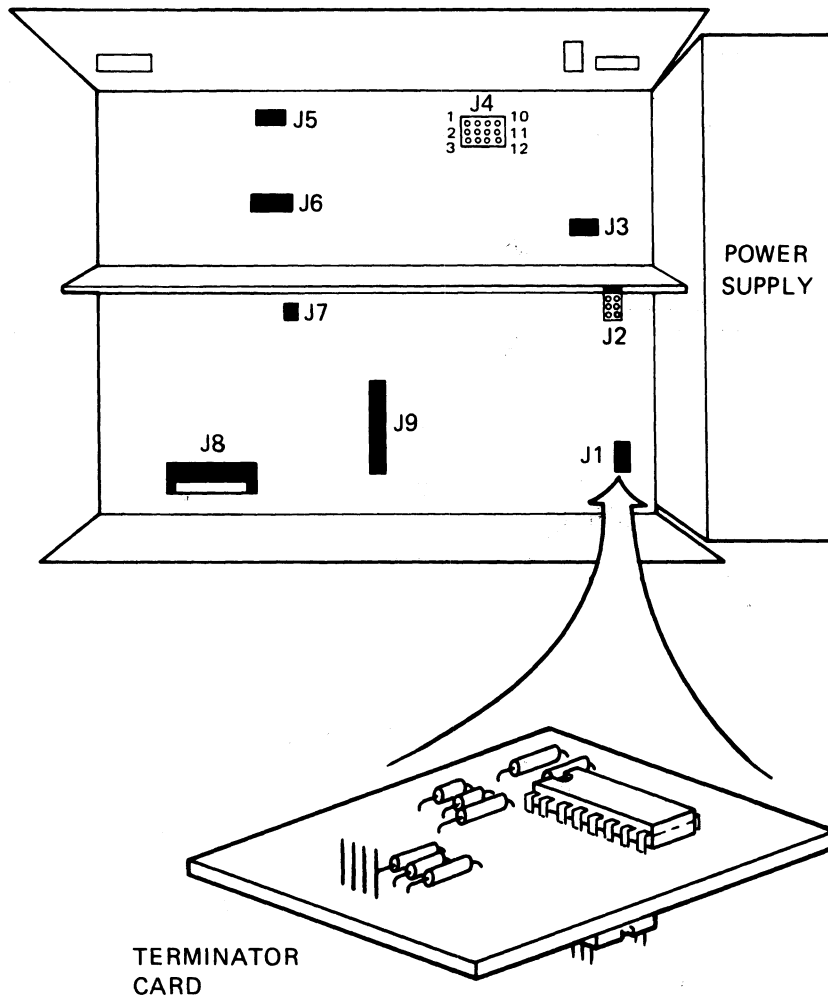

MA-4591

Figure 11-2 Terminator Card Removal

9. Route the end of the keyboard cable, with the notched connector, down through the cabinet and connect it to J1 on logic board. The notched end faces pin 1 on J1 (Figure 11-3).

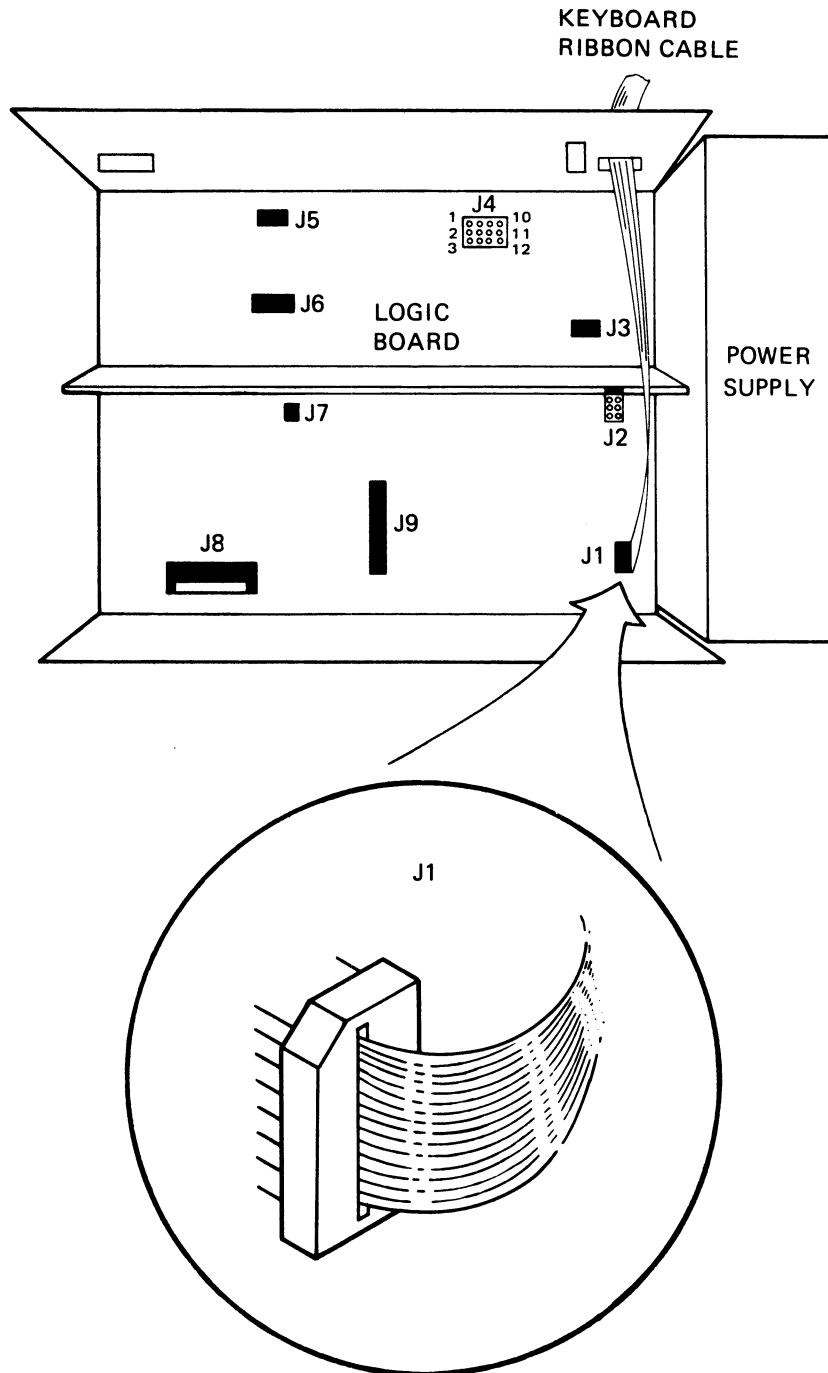

MA-4592

Figure 11-3 Keyboard Cable Installation



10. Connect the other end of the keyboard cable to J2 on the keyboard. The cable should enter the left side of the connector when inserted in J2 (Figure 11-4).

**NOTE**

To prevent scratching or damaging keyboard or keyboard bezel, rest keyboard bezel on a piece of foam or other cushioning material when performing the next step.

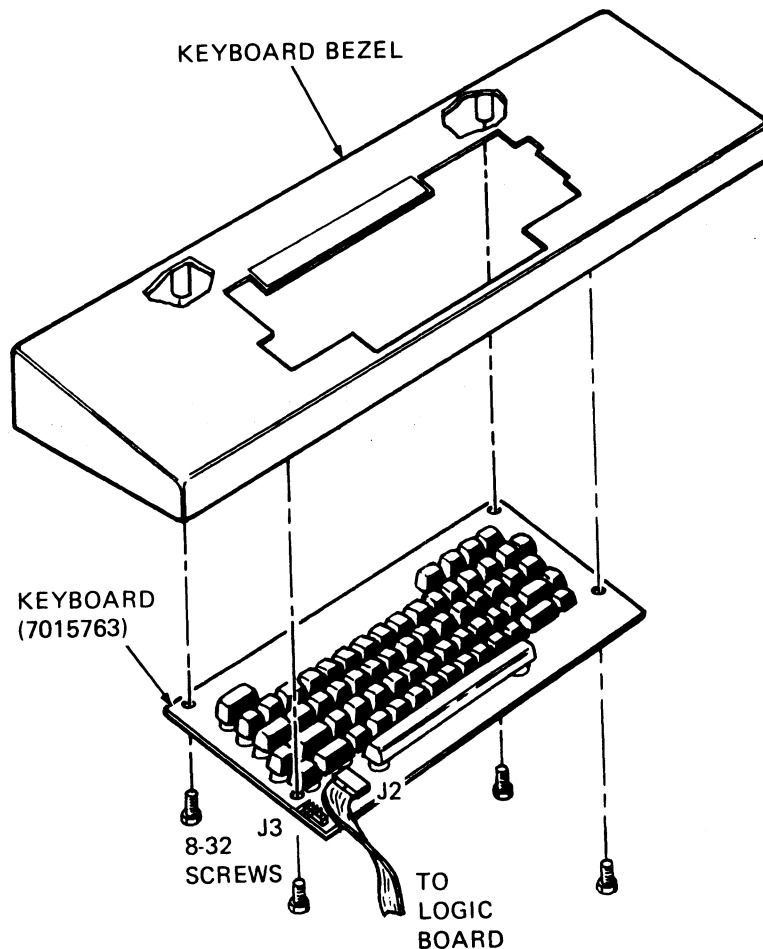

MA-4589

Figure 11-4 Keyboard Installation

11. Turn keyboard bezel upside down and secure keyboard with four (8-32) self-tapping screws (Figure 11-4).
12. Snap keyboard bezel into printer base.
13. Snap two plastic covers into keyboard bezel on either side of keyboard.

14. Attach legend strip and product designation labels to their appropriate space on keyboard bezel (Figure 11-5).

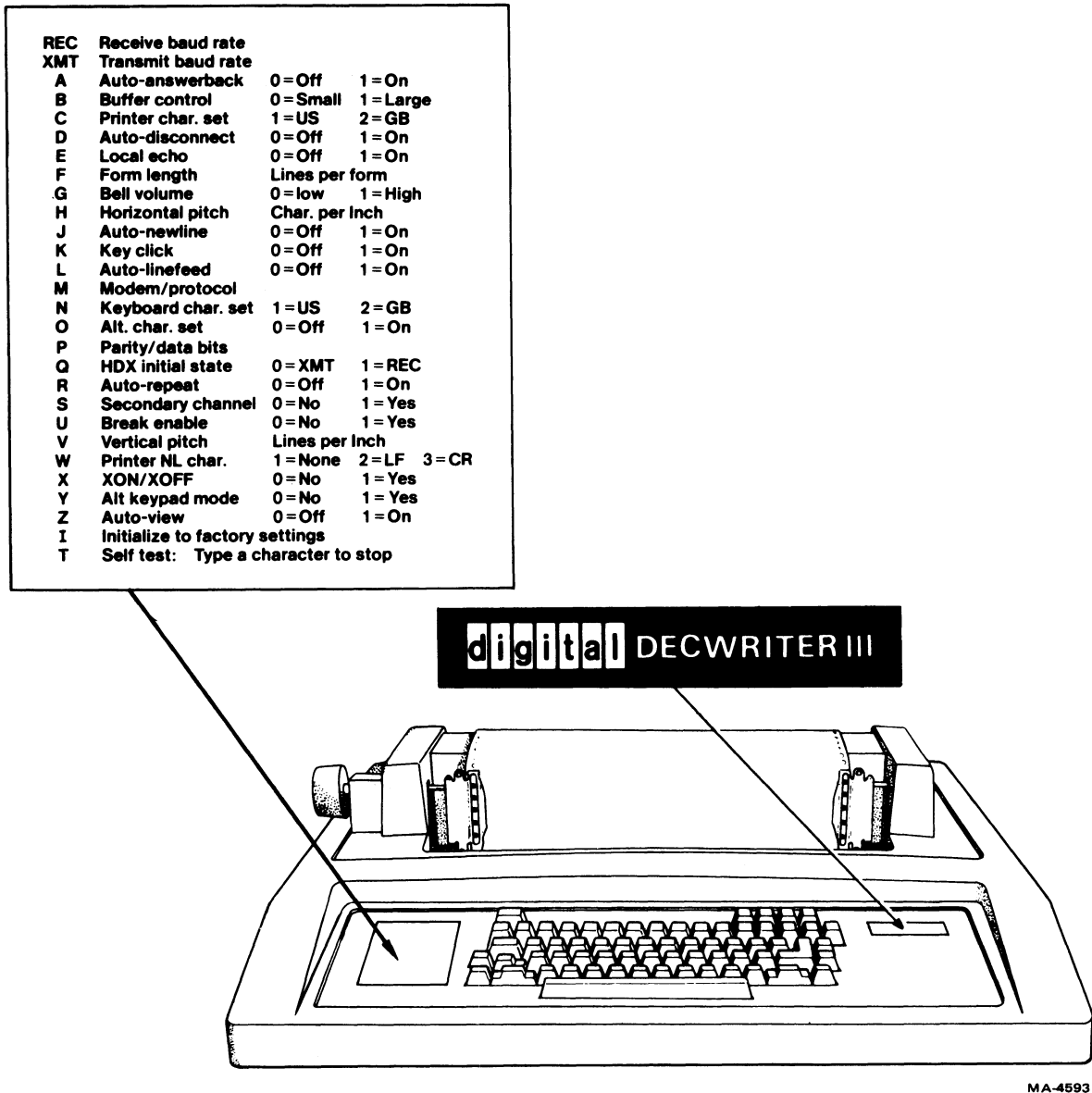

Figure 11-5 Label Installation

15. Place printer housing on cabinet base and secure it with six (6-32) self-tapping screws and flat washers.
16. Install printer paper and cover.
17. Restore power.
18. Perform self-test procedure described in Chapter 1, Part 2, of the *LA120 User Guide*.

### 11.3 OPERATOR'S INFORMATION

Refer to Chapter 1 to operate the LA120-RE with the LA12X-HL option installed.

## CHAPTER 12 LA12X-YL OPTION

### 12.1 INTRODUCTION

The LA12X-YL is a function keypad kit for use with the LA120-RE. When the LA12X-YL is installed, the LA120-RE remains receive only; however, the user now has the capability of modifying the SET-UP parameters.

### 12.2 INSTALLATION

Before installing the LA12X-YL, examine the installation kit to determine that it contains all the items listed in Table 12-1.

**Table 12-1 LA12X-YL Installation Kit**

Description	Part Number	Quantity
Keypad Assembly	7016799-00	1
Keyboard Cover Assembly	7016759-00	1
Keyboard Cable Assembly	1700120-00	1
Self-Tapping Screw	9010083-01	4
DECwriter III Label	3615684-00	1

To install the LA12X-YL on the LA120-RE, perform the following.

1. Remove power by disconnecting ac plug.
2. Remove printer paper and printer cover.
3. Remove six (6-32) self-tapping screws and flat washers that secure printer housing to cabinet base (Figure 12-1) and set them aside. Lift off printer housing and set aside.
4. Snap off cover from keyboard bezel.
5. Snap off keyboard bezel.
6. Open rear access door on cabinet.
7. Disconnect interlock/paper out cable from terminator in J1 on logic board and remove terminator card (Figure 12-2).
8. Route interlock/paper out cable up through cabinet and connect to J2 on keypad. The four-pin connector can be inserted in either direction.

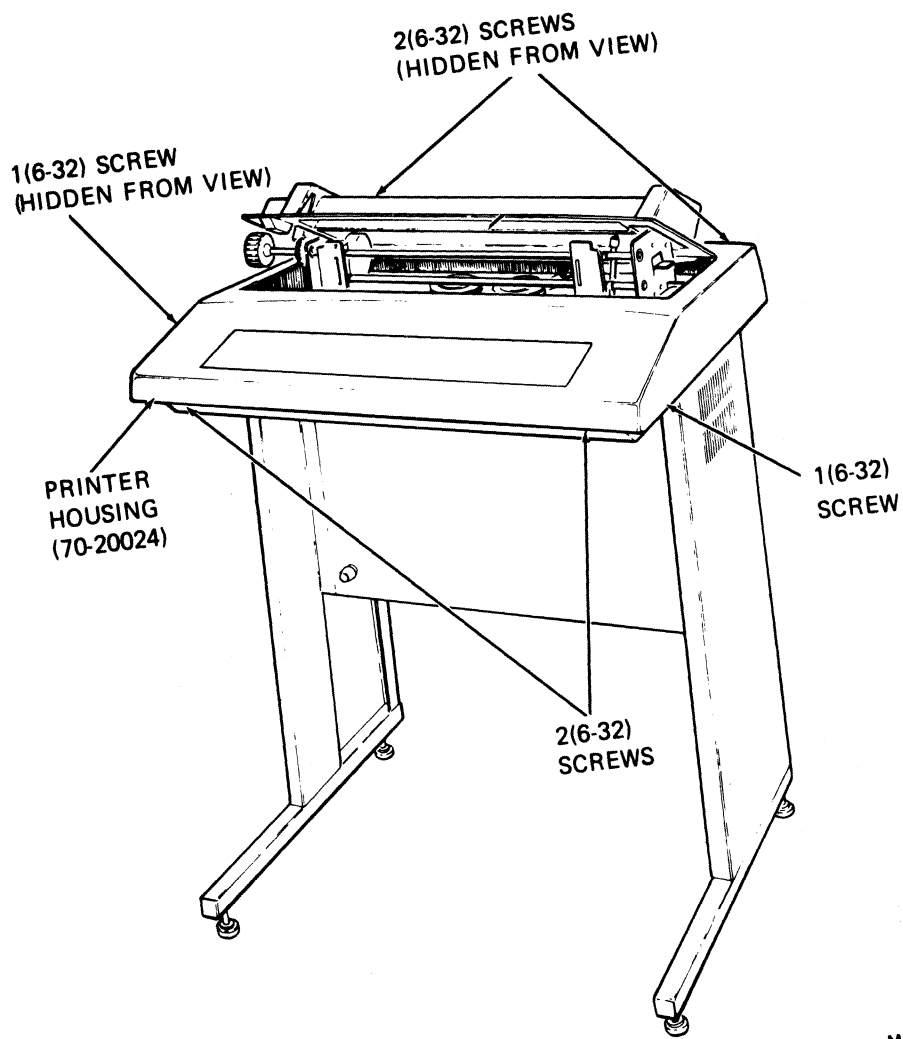
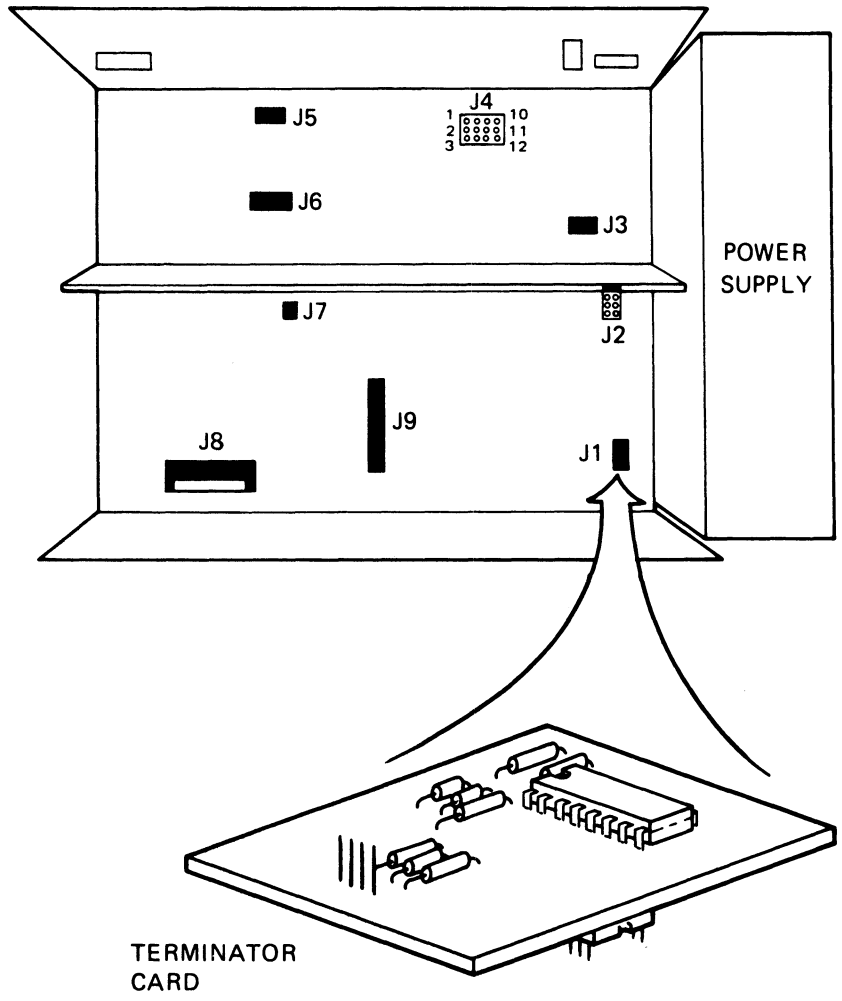

Figure 12-1 Printer Housing Removal and Installation



TERMINATOR  
CARD

MA-4591

Figure 12-2 Terminator Card Removal

9. Route the end of the keyboard cable, with the notched connector, down through the cabinet and connect it to J1 on the logic board. The notched end faces pin 1 on J1 (Figure 12-3).
10. Connect the other end of the keyboard cable to J1 on keypad. The cable should enter the bottom of the connector when inserted in J1 (Figure 12-4).

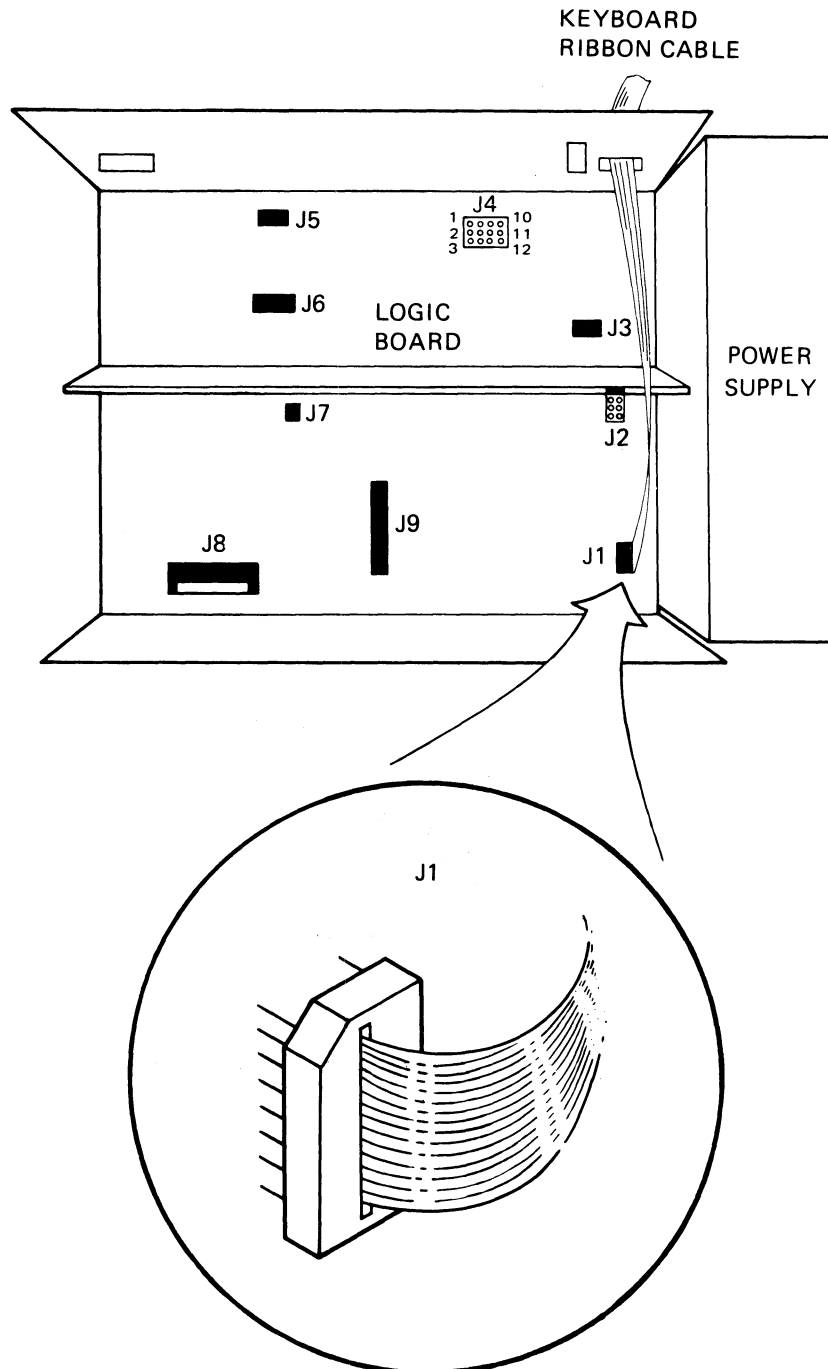

MA-4592

Figure 12-3 Keyboard Cable Installation

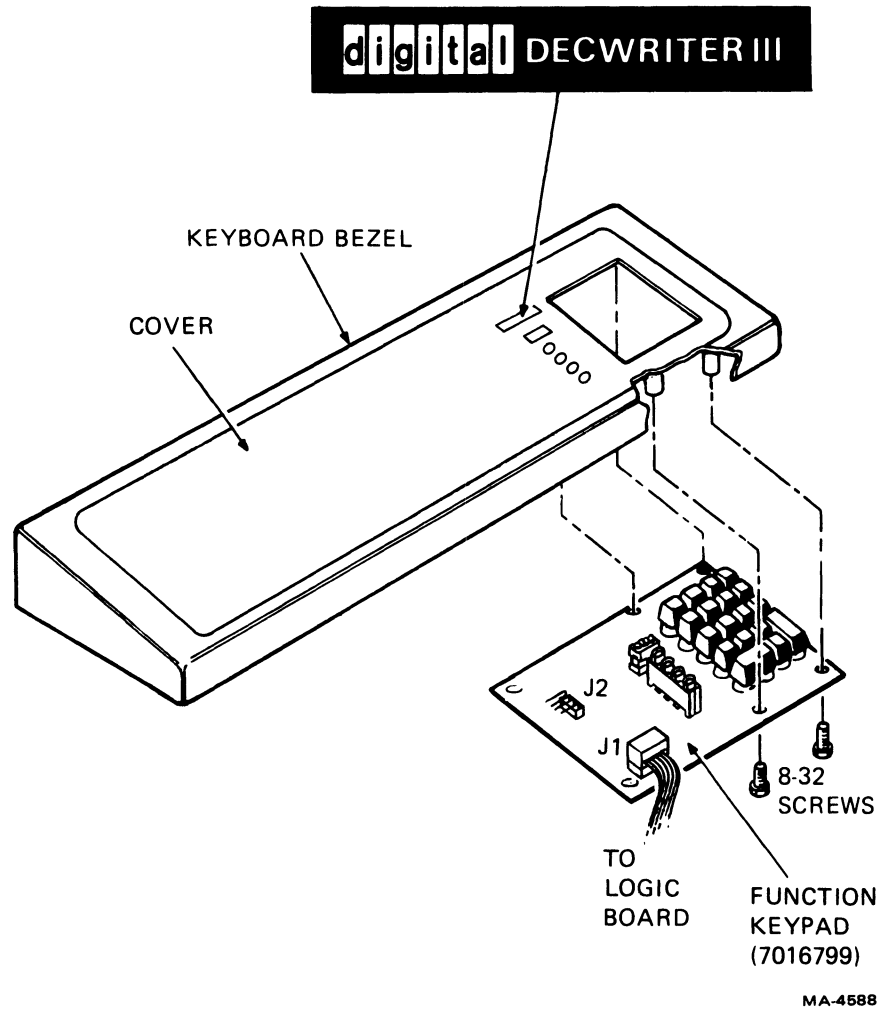

Figure 12-4 Keypad Installation

**NOTE**

**To prevent scratching or damaging the keypad or keyboard bezel, rest the keyboard bezel on a piece of foam or other cushioning material when performing the next step.**

11. Turn keyboard bezel upside down and secure keypad with four (8-32) self-tapping screws (Figure 12-4).
12. Snap keyboard bezel into printer base.
13. Snap keyboard cover assembly into keyboard bezel.
14. Attach product designation label to appropriate space on keyboard bezel (Figure 12-4).
15. Place printer housing on cabinet base and secure it with six (6-32) self-tapping screws and flat washers.

16. Install printer paper and cover.
17. Restore power.
18. Perform one of the two following self-test procedures given in Tables 12-2 and 12-3.

**Table 12-2 Printing Self-Test**

Procedure	Comments/Indication
Simultaneously press SET-UP LOCK and SET-UP.	Locks printer in SET-UP mode. Set-up light blinks.
Press SELF TEST.	Self-test pattern (Figure 12-5) will print out.
To stop test, press SELF TEST or any code producing character.	Exits from self-test. Pressing SET-UP will also exit from SET-UP mode.

**Table 12-3 Nonprinting Self-Test**

Procedure	Comments/Indication
Remove keyboard cover assembly.	Allows access to printed circuit board.
Simultaneously press SET-UP LOCK and SET-UP.	Locks printer in SET-UP mode.
Simultaneously press SHIFT and short the two split lugs on the left side of the keypad circuit board with a small screwdriver. Lugs are between J1 and J2 and are marked > key.	Same as printing self-test except spaces are substituted for printing characters.
To stop test, press SELF TEST or any code producing character.	Exits from self-test. Pressing SET-UP will also exit from SET-UP mode.

```

.,-./0123456789:;<=>?@ABCDEFGHIJKLMN0PQRSTUVWXYZ[\
-./0123456789:;<=>?@ABCDEFGHIJKLMN0PQRSTUVWXYZ[\]
.,/0123456789:;<=>?@ABCDEFGHIJKLMN0PQRSTUVWXYZ[\]^
./0123456789:;<=>?@ABCDEFGHIJKLMN0PQRSTUVWXYZ[\]^_
'0123456789:;<=>?@ABCDEFGHIJKLMN0PQRSTUVWXYZ[\]^_`
)123456789:;<=>?@ABCDEFGHIJKLMN0PQRSTUVWXYZ[\]^_`a
!3456789:;<=>?@ABCDEFGHIJKLMN0PQRSTUVWXYZ[\]^_`ab
!3456789:;<=>?@ABCDEFGHIJKLMN0PQRSTUVWXYZ[\]^_`abc
!456789:;<=>?@ABCDEFGHIJKLMN0PQRSTUVWXYZ[\]^_`abcd
!56789:;<=>?@ABCDEFGHIJKLMN0PQRSTUVWXYZ[\]^_`abcde
!6789:;<=>?@ABCDEFGHIJKLMN0PQRSTUVWXYZ[\]^_`abcdef
!789:;<=>?@ABCDEFGHIJKLMN0PQRSTUVWXYZ[\]^_`abcdefg

```

MA-4695

**Figure 12-5 Self-Test Printout**



## 12.3 OPERATOR'S INFORMATION

This section describes the function of the indicator lights and control keys and describes how the control keys are used.

### 12.3.1 Indicator Lights

#### NUMERIC Display

The numeric display indicates the current column number during normal operation. In SET-UP mode, the numeric display may also indicate line number, baud rate, form length, etc.

#### LINE Light

The LINE light indicates the LA120 is on-line. Data is received only while on-line.

#### DSR Light

The DSR light indicates the modem is in data mode (data set ready).

#### PAPER OUT Light

The PAPER OUT light flashes to indicate the printer is not ready, due to one of the following conditions.

- Paper out
- Cover open
- Print head jam

#### SET-UP Light

The SET-UP light flashes to indicate the LA120 is in SET-UP mode.

### 12.3.2 Control Keys

**LINE  
LOCAL**

The LINE/LOCAL key switches the LA120 to or from line or local, as indicated by the LINE light.

**BAUD  
RATE**

The BAUD RATE key selects the baud rate and number of stop bits.

**SELF  
TEST**

The SELF TEST key selects the printing self-test feature.

**PAR  
SEL**

The PAR SEL key selects the type of parity and the number of data bits.

**SHIFT**

The SHIFT key, when pressed, causes the numeric display to indicate current line number. The SHIFT key is also used during SET-UP mode as a control key.

**SET  
TAB**

The SET TAB key sets a horizontal tab stop at the current column.

CLR  
ALL  
TABS

The CLR ALL TABS key clears all horizontal tabs.

LOC  
FORM  
FEED

The LOC FORM FEED key causes a form feed.

SPACE

The SPACE key generates code for a space.

FORMS  
LENGTH

The FORMS LENGTH key selects the form length in lines.

PTR  
NEW  
LINE

The PTR NEW LINE key controls the selection of the printer's response to a received line feed or carriage return.

LOC  
LINE  
FEED

The LOC LINE FEED key advances the paper one line at a time.

SET  
UP  
LOCK

The SET-UP LOCK key, when simultaneously pressed with the SET-UP key, locks the LA120 in SET-UP mode.

MODEM

The MODEM key enables the selection of a communications protocol.

SEC  
CHAN

The SEC CHAN key enables selection of a restraint mode for full duplex operation or indication of the presence of a secondary channel for half duplex operation.

S  
T  
A  
T  
U  
S

The STATUS key causes a message containing the currently selected values of the SET-UP parameters to be printed.

**SET-UP**

The SET-UP key is used to examine or change the SET-UP parameters.

**STORE  
RECALL**

The STORE RECALL key is pressed to recall the stored SET-UP parameters. When simultaneously pressed with the SHIFT key, the current SET-UP parameters are stored.

**12.3.3 SET-UP Mode**

LA120 parameters can be changed only while in the SET-UP mode. Normally four steps are required to perform SET-UP.

1. Enter SET-UP.
2. Change a parameter such as tabs, baud rate, etc.
3. Store the parameter if desired (see note).
4. Exit SET-UP.

**NOTE**

**Storing enables the selected parameter to be stored permanently. For detailed information, refer to the storage, recall, and status description in the LA120 User Guide.**

SET-UP should be performed with the LA120 in local mode.

Table 12-4 describes the two methods of entering and exiting SET-UP.

**Table 12-4 Entering/Exiting SET-UP Mode**

<b>Method No.</b>	<b>Procedure</b>	<b>Indication/Comments</b>
1	While holding SET-UP LOCK, press SET-UP; release both keys. You may now change any SET-UP feature.  Press SET-UP if you wish to exit SET-UP.	SET-UP lamp flashes indicating you have entered SET-UP.  SET-UP lamp will stop flashing.
2	Press and hold SET-UP. You must continue to hold the SET-UP key while changing any feature.  Release SET-UP if you wish to exit SET-UP.	SET-UP lamp flashes indicating you are in SET-UP.  SET-UP lamp will stop flashing.

### 12.3.4 Baud Rate (Speed)

Baud rate is the speed that data moves to the LA120. Due to the many systems the user must communicate with, a large selection of baud rates are available. Select the desired baud rate using the procedure in Table 12-5.

**Table 12-5 Baud Rate Selection**

Procedure	Indication/Comments																																															
Enter SET-UP mode.	SET-UP lamp flashes indicating you are in SET-UP.																																															
Press BAUD RATE.	Current selection of baud rate is displayed.																																															
Continue pressing BAUD RATE to select receive baud rate as indicated by numeric display.	<table border="1"> <thead> <tr> <th data-bbox="844 704 1058 825">Baud Rate (Displayed)</th> <th data-bbox="1058 704 1230 825">Actual Baud Rate</th> <th data-bbox="1230 704 1344 825">Stop Bits</th> </tr> </thead> <tbody> <tr><td>50</td><td>50</td><td>2</td></tr> <tr><td>75</td><td>75</td><td>2</td></tr> <tr><td>110</td><td>110</td><td>2</td></tr> <tr><td>134</td><td>134.5</td><td>1</td></tr> <tr><td>150</td><td>150</td><td>1</td></tr> <tr><td>200</td><td>200</td><td>1</td></tr> <tr><td>300</td><td>300</td><td>1</td></tr> <tr><td>600</td><td>600</td><td>1</td></tr> <tr><td>1200</td><td>1200</td><td>1</td></tr> <tr><td>1800</td><td>1800</td><td>1</td></tr> <tr><td>2400</td><td>2400</td><td>1</td></tr> <tr><td>4800</td><td>4800</td><td>1</td></tr> <tr><td>7200</td><td>7200</td><td>1</td></tr> <tr><td>9600</td><td>9600</td><td>1</td></tr> </tbody> </table>			Baud Rate (Displayed)	Actual Baud Rate	Stop Bits	50	50	2	75	75	2	110	110	2	134	134.5	1	150	150	1	200	200	1	300	300	1	600	600	1	1200	1200	1	1800	1800	1	2400	2400	1	4800	4800	1	7200	7200	1	9600	9600	1
	Baud Rate (Displayed)	Actual Baud Rate	Stop Bits																																													
	50	50	2																																													
	75	75	2																																													
	110	110	2																																													
	134	134.5	1																																													
	150	150	1																																													
	200	200	1																																													
	300	300	1																																													
	600	600	1																																													
	1200	1200	1																																													
	1800	1800	1																																													
	2400	2400	1																																													
4800	4800	1																																														
7200	7200	1																																														
9600	9600	1																																														

### 12.3.5 Parity and Data Bits

Parity enables data errors to be monitored and thereby verifies the correctness of data. If an error in transmission has occurred, the LA120 can detect it and indicate its presence by printing a special symbol ( ¶ ). In addition to parity, this feature enables the selection of 7 or 8 data bits. Select the parity and data bits using the procedure in Table 12-6.

**Table 12-6 Parity/Data Bits Selection**

Procedure	Comments/Indication		
Enter SET-UP mode.	SET-UP lamp flashes indicating you are in SET-UP.		
Press PAR SEL.	Current selection of parity bits is displayed in numeric display.		
Continue pressing PAR SEL to select parity and data bits as indicated by numeric display.			
	<b>Numeric Display Indicates</b>	<b>Data Bits</b>	<b>Parity Receive</b>
	1	7	Ignore
	2	7	Ignore
	3	7	Ignore
	4	7	Ignore
	5	7	Odd
	6	7	Even
	7	7	None
	8	8	None
9	8	Odd	
10	8	Even	
Exit SET-UP.	SET-UP lamp will stop flashing.		

**12.3.6 Setting Form Length**

The LA120 measures form length in lines per form. To determine how long your form is, measure the length of the form (Figure 12-6) in inches; then multiply the length of the form by the lines per inch in memory. (Lines per inch is factory set at six.)

Form Length = Length of Form in Inches × Number of Lines per Inch in Memory.

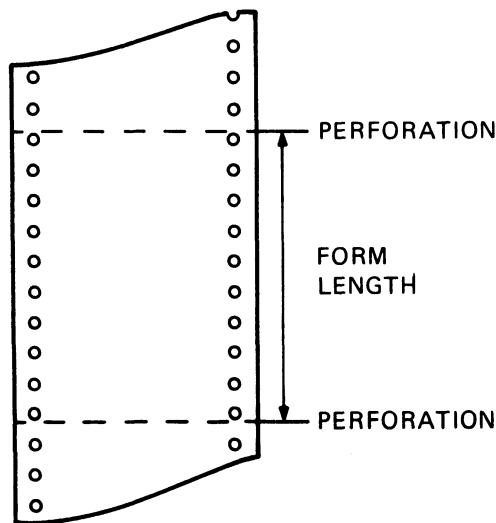

MA-4594

Figure 12-6 Form Length

Use the procedure in Table 12-7 to enter the number of lines per form. Your choices of form length range from 1 to 168 lines.

**NOTE**  
**Changing form length clears top and bottom margins, and sets the current line number to 1.**

**Table 12-7 Form Length Selection**

Procedure	Indication/Comments
Enter SET-UP mode.	SET-UP lamp flashes indicating that you are in SET-UP.
Press FORMS LENGTH.	Current form length in lines is displayed by numeric display.
Repeat pressing FORMS LENGTH to change form length.	Numeric display will indicate a new value each time FORMS LENGTH is pressed. Stop when desired number of lines is displayed.
Exit SET-UP.	SET-UP lamp will stop flashing.

**12.3.7 Printer New Line Character**

This feature controls the way the LA120 responds to the received line feed or carriage return code. Three different responses can be selected as described in Table 12-8.

**Table 12-8 Carriage Return/Line Feed Responses**

Selections Indicated by Numeric Display	Received Carriage Return Code	Received Line Feed Code
1	LA120 performs a carriage return.	LA120 performs a line feed.
2	LA120 performs a carriage return.	LA120 performs a carriage return and line feed.
3	LA120 performs a carriage return and line feed.	LA120 performs a line feed.

**NOTE**  
**In choice 2, the LA120 also performs a carriage return when it receives vertical tab and form feed characters.**

The procedure for selecting the desired response is given in Table 12-9.

**Table 12-9 Selection of Carriage Return/Line Feed Responses**

Procedure	Comments/Indications									
Enter SET-UP mode.	SET-UP lamp flashes indicating you are in SET-UP.									
Press PTR NEW LINE.	Current selection of printer new line character is displayed in numeric display.									
Continue pressing PTR NEW LINE.	Numeric display indicates one of the following:  <table style="margin-left: 20px;"> <tr> <td style="border: none;">1</td> <td style="border: none;">}</td> <td style="border: none;">(Table 12-8)</td> </tr> <tr> <td style="border: none;">2</td> <td style="border: none;">}</td> <td style="border: none;"></td> </tr> <tr> <td style="border: none;">3</td> <td style="border: none;">}</td> <td style="border: none;"></td> </tr> </table>	1	}	(Table 12-8)	2	}		3	}	
1	}	(Table 12-8)								
2	}									
3	}									
Exit SET-UP.	SET-UP lamp will stop flashing.									

**12.3.8 Modem**

This feature enables the selection of a protocol that matches the communication requirements (see Communications Chapter in *LA120 User Guide*). Refer to Paragraph 12.3.9 (Secondary Channel) for related modem SET-UPS. Selectable protocols are listed below.

1. FDX (Full Duplex), No Modem
2. FDX, Modem
3. HDX (Half Duplex), Supervisory
4. HDX, EOT
5. HDX, EXT

Table 12-10 gives the procedure for modem selection.

**Table 12-10 Modem Selection**

Procedure	Comments/Indications												
Enter SET-UP mode.	SET-UP lamp flashes indicating you are in SET-UP.												
Press MODEM.	Current selection of modem is displayed in numeric display.												
Continue pressing MODEM to change numeric display.	<table border="1" style="width: 100%; border-collapse: collapse;"> <thead> <tr> <th style="text-align: left;">Numeric Display Indicates</th> <th style="text-align: left;">Description</th> </tr> </thead> <tbody> <tr> <td>1</td> <td>FDX, No Modem</td> </tr> <tr> <td>2</td> <td>FDX, Modem</td> </tr> <tr> <td>3</td> <td>HDX, Supervisory</td> </tr> <tr> <td>4</td> <td>HDX, EOT</td> </tr> <tr> <td>5</td> <td>HDX, ETX</td> </tr> </tbody> </table>	Numeric Display Indicates	Description	1	FDX, No Modem	2	FDX, Modem	3	HDX, Supervisory	4	HDX, EOT	5	HDX, ETX
Numeric Display Indicates	Description												
1	FDX, No Modem												
2	FDX, Modem												
3	HDX, Supervisory												
4	HDX, EOT												
5	HDX, ETX												
Exit SET-UP.	SET-UP lamp will stop flashing.												

### 12.3.9 Secondary Channel

This feature has two meanings. First, if modem choices 1 or 2 (full duplex) have been selected, the secondary channel feature can be used to indicate the restraint mode. The second meaning applies when half-duplex modem choices 4 or 5 have been selected. With this choice, the secondary channel feature can be used to indicate the presence of a secondary (reverse) channel. Table 12-11 gives the procedure for secondary channel selection.

**Table 12-11 Secondary Channel Selection**

Procedure	Comments/Indications		
Enter SET-UP mode.	SET-UP lamp flashes indicating you are in SET-UP.		
Press SEC CHAN.	Current selection of secondary channel is displayed in numeric display.		
Continue pressing SEC CHAN.	<b>Numeric Display Indicates</b>	<b>Modem 1 or 2 Selected</b>	<b>Modem 4 or 5 Selected</b>
	0	Speed Control Mode	Secondary Channel - No
	1	Restraint Mode	Secondary Channel - Yes
Exit SET-UP.	SET-UP lamp will stop flashing.		



### 12.3.10 Status

A special feature of the LA120 is a printout of all the current SET-UP values except tabs and margins. The following is a sample printout of a typical status message using the factory parameters.

REC	1200
XMT	1200
A	0
B	1
C	1
D	1
E	0
F	66
G	1
H	10
J	1
K	0
L	0
M	1
N	1
O	1
P	1
Q	0
R	1
S	0
U	1
V	6
W	1
X	1
Y	0
Z	1

Refer to the legend strip label in Figure 11-5 for interpretation of codes.

#### NOTE

**Do not press SHIFT when printing out status message.**

To obtain a status printout, follow the procedure in Table 12-12.

**Table 12-12 Status Printout Procedure**

Procedure	Indication/Comments
Enter SET-UP mode.	SET-UP light will flash when LA 120 is in SET-UP.
Press STATUS.	Status message will be printed out.
Exit SET-UP.	SET UP light will stop flashing.

### 12.3.11 Store/Recall

Normally, setting up the LA120 is a one-time job. This is due to a unique feature that stores all the settings in a permanent memory. Thus, the LA120 can be turned off without losing the following settings:

Horizontal tab stop	Auto new line
Vertical tab stops	Key click
Left margin	Auto line feed
Right margin	Modem
Top margin	Keyboard and printer character set
Bottom margin	HDX initial calling state
Line/local status	Auto repeat
Baud rate	Secondary channel
Answerback	XON/XOFF
Buffer control	Alternate keypad mode
Printer character set	Auto view
Auto disconnect	Printer new line character
Local echo	Alternate character set
Form length	Break action
Horizontal Pitch	

When the LA120 is turned on it will automatically enter the last settings stored by the operator.

#### NOTE

**Setups must be stored to be saved.**

Tables 12-13 and 12-14 contain the procedures for respectively storing and recalling LA120 settings.

**Table 12-13 LA120 Store Procedure**

Procedure	Comments/Indication
Enter SET-UP mode.	SET UP light will start flashing indicating you are in SET-UP.
Press and hold SHIFT and press STORE RECALL.	All settings in the operating memory are stored in nondestructive memory. Numeric display will go blank for a few seconds.
Exit SET-UP.	SET-UP lamp will stop flashing.

**Table 12-14 LA120 Recall Procedure**

Procedure	Comments/Indication
Enter SET-UP mode.	SET UP light will start flashing indicating you are in SET-UP.
Press STORE RECALL.	Settings stored in permanent memory will be recalled. Numeric display will go blank for a few seconds.
Exit SET-UP.	SET-UP lamp will stop flashing.

**APPENDIX A**  
**LA120 OPERATOR REFERENCE CARD**

**digital** **DECWRITER III**

**LA120 OPERATOR  
REFERENCE CARD**

---

---

**SET-UP**

KEY	FUNCTION/COMMENTS
<b>CTRL</b> and <b>SET-UP</b>	Locks LA120 in set-up mode. SET-UP light flashes. To exit set-up mode press <b>SET-UP</b>
<b>SET-UP</b>	Places LA120 in set-up mode while <b>SET-UP</b> is held down. SET-UP light flashes. To exit set-up mode release <b>SET-UP</b>

**NOTES:**

1. LA120 must be in set-up mode to set the following features.
2. Do not use **SHIFT** unless specified.

---

---

**FORMS**

KEY	FUNCTION/COMMENTS
<b>SHIFT</b>	Display current line number Releasing <b>SHIFT</b> returns display to current column number
<b>1</b>	Set horizontal tab at current column
<b>SHIFT</b> and <b>1</b>	Set vertical tab at current line
<b>2</b>	Clear horizontal tab at current column
<b>SHIFT</b> and <b>2</b>	Clear vertical tab at current line
<b>3</b>	Clear all horizontal tabs
<b>SHIFT</b> and <b>3</b>	Clear all vertical tabs
<b>4</b> or <b>SHIFT</b> and <b>4</b>	Establish top of form (TOF)
<b>5</b>	Set minimum column number (left margin)
<b>SHIFT</b> and <b>5</b>	Set minimum line number (top margin)
<b>6</b>	Set maximum column number (right margin)
<b>SHIFT</b> and <b>6</b>	Set maximum line number (bottom margin)
<b>7</b>	Clear left and right margins
<b>SHIFT</b> and <b>7</b>	Clear top and bottom margins
<b>F</b>	Form Length NOTE Changing form length clears top and bottom margins and establishes TOF.

**DISPLAY**

1  
thru } Lines per form  
168 }

## FORMS (CONT)

### KEY FUNCTION/COMMENTS

**H**

Horizontal pitch (Characters per inch)

NOTE: Changing horizontal pitch clears left and right margins.

<u>DISPLAY</u>	<u>PITCH</u>
5	5.00 CPI
6	6.00 CPI
7	6.60 CPI
8	8.25 CPI
10	10.0 CPI
12	12.0 CPI
13	13.2 CPI
16	16.5 CPI

**V**

Vertical pitch (Lines per inch)

NOTE: Changing vertical pitch clears top and bottom margins.

<u>DISPLAY</u>	<u>PITCH</u>
2	2 LPI
3	3 LPI
4	4 LPI
6	6 LPI
8	8 LPI
12	12 LPI

---

## OPERATOR COMFORT

### KEY FUNCTION/COMMENTS

**G**

Bell volume

0 = Low Volume

1 = High Volume

**K**

Key click

0 = Off

1 = On

**R**

Auto repeat

0 = Off

1 = On

**Z**

Last character view

0 = Manual

1 = Auto

---

## COMMUNICATION

### KEY FUNCTION/COMMENTS

**A**

Auto answerback

0 = Off

1 = On

**B**

Buffer control

0 = Small

1 = Large

**C**

Printer character set

1 = United States

2 = United Kingdom

**D**

Auto disconnect

0 = Off

1 = On

**E**

Local echo

0 = Off

1 = On

**COMMUNICATION (CONT)**

**KEY FUNCTION/COMMENTS**

**J** Auto new line at right margin  
 0 = Off  
 1 = On

**L** Auto line feed (Return key)  
 0 = Off  
 1 = On

**M** Modem  
 1 = FDX. No Modem  
 2 = FDX. Modem  
 3 = HDX. Supervisory  
 4 = HDX. EOT  
 5 = HDX. ETX

**N** Keyboard and printer character set  
 1 = United States  
 2 = United Kingdom

**O** (letter) Alternate character set  
 0 = OFF  
 1 = ON

**P** Parity and data bits

DISPLAY	DATA BITS	PARITY	
		REC	XMT
1	7	IGNORE	MARK
2	7	IGNORE	SPACE
3	7	IGNORE	ODD
4	7	IGNORE	EVEN
5	7	ODD	ODD
6	7	EVEN	EVEN
7	7	NONE	NONE
8	8	NONE	NONE
9	8	ODD	ODD
10	8	EVEN	EVEN

**Q** HDX initial calling state  
 0 = Transmit  
 1 = Receive

**S** Secondary channel

DISPLAY	FDX *	HDX *
	MODE	REV.CH
0	Speed	No
1	Restraint	Yes

\* See M Key, Modem

**U** Break enabled  
 0 = No  
 1 = Yes

**W** Printer new line character  
 1 = None  
 2 = Line feed (LF)  
 3 = Return (CR)

**X** XON/XOFF  
 0 = No  
 1 = Yes

**Y** Alternate keypad mode  
 0 = No  
 1 = Yes

**COMMUNICATION (CONT)**

**KEY**                      **FUNCTION/COMMENTS**  
 (number)      Selects receive and transmit baud rates and number of stop bits.

BAUD RATE (DISPLAYED)	STOP BITS
50	2
75	2
110	2
134	1
150	1
200	1
300	1
600	1
1200	1
1800	1
2400	1
4800	1
7200	1
9600	1

and       Selects split baud rates:  
 selects receive baud rate;  and  then offers a choice of three transmit baud rates

RECEIVE BAUD RATE (NOT DISPLAYED)	TRANSMIT BAUD RATE (DISPLAYED)	TRANSMIT STOP BITS
600	75	2
	150	1
	600	1
1200	75	2
	150	1
	1200	1
2400	300	1
	600	1
	2400	1
4800	300	1
	600	1
	4800	1

**STORE RECALL AND STATUS**

**KEY**                      **FUNCTION/COMMENTS**  
 (letter)      Select factory set-up parameters  
                      Print status message  
                      Recall set-up parameters  
 and       Store set-up parameters

**SELF TEST**

**KEY**                      **FUNCTION/COMMENTS**  
                      Initiate printing self test  
 and       Initiate non-printing self test  
 NOTE: Type any character in set-up mode to stop self test.

Copyright © 1978 by Digital Equipment Corporation

PRINTED IN U.S.A. EK-LA120-RG-001

## APPENDIX B FACTORY PARAMETER SETTINGS

The initial settings of the LA120 parameters made at the factory prior to shipment are given below.

<b>Parameter</b>	<b>Setting</b>
Horizontal tab stops	1, 9, 17, 25, 33, 41, 49, 57, 65, 73, 81, 89, 97, 105, 113, 121, 129, 137, 145, 153, 161, 169, 177, 185, 193, 201, 209, 217
Vertical tab stops	1, 9, 17, 25, 33, 41, 49, 57, 65, 73, 81, 89, 97, 105, 113, 121, 129, 137, 145, 153, 161
Left margin	1
Right margin	132
Top margin	1
Bottom margin	66
Line/Local Status	On-line
REC	1200
XMT	1200
A	0
B	1
C	1
D	1
E	0
F	66
G	1
H	10
J	1
K	0
L	0
M	1
N	1
O	1
P	1
Q	0
R	1
S	0
U	1
V	6
W	1
X	1
Y	0
Z	1





Your comments and suggestions will help us in our continuous effort to improve the quality and usefulness of our publications.

What is your general reaction to this manual? In your judgement is it complete, accurate, well organized, well written, etc? Is it easy to use? \_\_\_\_\_

\_\_\_\_\_  
\_\_\_\_\_

What features are most useful? \_\_\_\_\_

\_\_\_\_\_  
\_\_\_\_\_

What faults or errors have you found in the manual? \_\_\_\_\_

\_\_\_\_\_  
\_\_\_\_\_

Does this manual satisfy the need you think it was intended to satisfy? \_\_\_\_\_

Does it satisfy *your* needs? \_\_\_\_\_ Why? \_\_\_\_\_

\_\_\_\_\_  
\_\_\_\_\_

- Please send me the current copy of the *Technical Documentation Catalog*, which contains information on the remainder of DIGITAL's technical documentation.

Name \_\_\_\_\_ Street \_\_\_\_\_

Title \_\_\_\_\_ City \_\_\_\_\_

Company \_\_\_\_\_ State/Country \_\_\_\_\_

Department \_\_\_\_\_ Zip \_\_\_\_\_

Additional copies of this document are available from:

Digital Equipment Corporation  
Accessories and Supplies Group  
Cotton Road  
Nashua, NH 03060

Attention *Documentation Products*  
Telephone 1-800-258-1710

Order No.       EK-LA120-TM-001

-----  
**Fold Here**-----

-----  
**Do Not Tear -- Fold Here and Staple**-----

**digital**



**No Postage  
Necessary  
if Mailed in the  
United States**

**BUSINESS REPLY MAIL**

FIRST CLASS PERMIT NO. 33 MAYNARD, MA.

POSTAGE WILL BE PAID BY ADDRESSEE

**Digital Equipment Corporation  
Educational Services Development and Publishing  
129 Parker Street, PK3-1/T12  
Maynard, MA 01754**

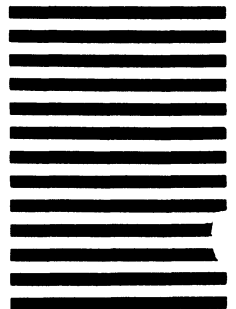



**digital**