

DIGITAL EQUIPMENT CORPORATION

typeset8
...dedicated to the
future of Graphic Arts

**typeset-8 systems—
positive logic
maintenance manual**

DIGITAL EQUIPMENT CORPORATION

typeset8
...dedicated to the
future of Graphic Arts

**typeset-8 systems—
positive logic
maintenance manual**

DIGITAL EQUIPMENT CORPORATION

typeset8
...dedicated to the
future of Graphic Arts

**typeset-8 systems—
positive logic
maintenance manual**

digital

DIGITAL EQUIPMENT CORPORATION

typeset8
...dedicated to the
future of Graphic Arts

**typeset-8 systems—
positive logic
maintenance manual**

digital

DIGITAL EQUIPMENT CORPORATION

typeset8

...dedicated to the
future of Graphic Arts

**typeset-8 systems—
positive logic
maintenance manual**

digital



**typeset-8 systems—
positive logic
maintenance manual**

DEC-08-HMMPA-A-D

1st Edition October 1972

Copyright © 1972 by Digital Equipment Corporation

The material in this manual is for informational purposes and is subject to change without notice.

The following are trademarks of Digital Equipment Corporation, Maynard, Massachusetts:

DEC	PDP
FLIP CHIP	FOCAL
DIGITAL	COMPUTER LAB

CONTENTS

	Page
CHAPTER 1 INTRODUCTION	
1.1 System Description	1-2
1.2 Specifications	1-3
CHAPTER 2 INSTALLATION	
2.1 Cabling and Terminations	2-1
2.2 Power Connections	2-5
2.3 Installation Verification	2-5
CHAPTER 3 OPERATION AND PROGRAMMING	
3.1 Program Instructions	3-1
3.2 Data Formats	3-1
3.3 Controls and Indicators	3-3
3.3.1 PR68B High-Speed Paper-Tape Reader	3-3
3.3.2 PR68D High-Speed Paper-Tape Reader	3-4
3.3.3 PR68DA High-Speed Paper-Tape Reader	3-5
3.3.4 PA63 Multiple Reader/Punch Control and Interface Unit	3-5
3.3.5 PP67C/D High-Speed Paper-Tape Punch	3-7
CHAPTER 4 THEORY OF OPERATION	
4.1 PA63 Multiple Reader/Punch Control and Interface Unit	4-1
4.1.1 Power Up	4-2
4.1.2 IOT Decoder for Reader Control	4-2
4.1.3 Reader Selection	4-2
4.1.4 Tape Reading	4-3
4.1.5 IOT Decoder for Punch Control	4-5
4.1.6 Punch Selection	4-6
4.1.7 Tape Punching	4-6
4.2 PA68F Single Reader/Punch Control and Interface Unit	4-8
4.2.1 Power Up	4-8
4.2.2 IOT Decoder for Reader Control	4-8
4.2.3 Tape Reading	4-9
4.2.4 IOT Decoder for Punch Control	4-11
4.2.5 Tape Punching	4-12
4.3 PR68B High-Speed Paper-Tape Reader	4-13
4.4 PR68D High-Speed Paper-Tape Reader	4-13
4.4.1 Tape Transport Mechanism	4-15
4.4.2 Photoelectric Tape Reader	4-15
4.4.3 NTTA Reader Selection	4-15
4.5 PR68DA High-Speed Paper-Tape Reader	4-16
4.6 PP67C/D High-Speed Paper-Tape Punch	4-16
4.6.1 Motor Control	4-17
4.6.2 Solenoid Control	4-18

CONTENTS (Cont)

	Page
CHAPTER 5 ADJUSTMENTS	
5.1	M401 Reader Clock 5-1
5.2	M710 Punch Control 5-1
5.3	PR68B High-Speed Paper-Tape Reader 5-4
5.3.1	Static Adjustment 5-6
5.3.2	Dynamic Adjustment 5-9
5.4	PR68D/DA High-Speed Paper-Tape Reader 5-10
5.4.1	Tape Guide 5-12
5.4.2	Tape Level Slide 5-12
5.4.3	Lamp Selection and Voltage 5-12
5.4.4	Sprocket Wheel and Condensing Lens 5-13
5.4.5	G918 Amplifier Adjustment 5-14
5.5	PP67C/D High-Speed Paper-Tape Punch 5-16
5.5.1	Punch Mechanism Adjustment 5-16
5.5.2	Low Tape Adjustment 5-17
5.6	4 ms Change Reader Delay 5-18
5.7	1 Second Change Punch Delay 5-19
5.8	Mixed Tape Levels 5-20
CHAPTER 6 MAINTENANCE	
6.1	Test Equipment and Diagnostic Programs 6-1
6.2	Preventive Maintenance 6-3
6.3	Spare Parts 6-3
APPENDIX A GLOSSARY OF TERMS	
APPENDIX B ENGINEERING DRAWINGS	
B.1	Engineering Drawings B-1

ILLUSTRATIONS

Figure No.	Title	Page
1-1	Typeset-8 System — Positive Logic	1-1
1-2	Multiple Reader/Punch System	1-2
1-3	Single Reader/Punch System	1-3
2-1	PR68B Reader/Interface Cable Interconnection	2-2
2-2	PR68D/DA Reader/Interface Cable Interconnection	2-3
2-3	PP67C/D Punch/Interface Cable Interconnection	2-4
2-4	M978 Connector Module	2-4
2-5	M979 Connector Module	2-5
3-1	Paper-Tape Formats	3-2
3-2	PR68B Reader	3-3
3-3	PR68D/DA Reader	3-4
3-4	PA63 Multiple Reader/Punch Control	3-5
3-5	PP67C/D Punch Controls	3-7
4-1	Tape Reader Timing Sequence for PA63	4-3

ILLUSTRATIONS (Cont)

Figure No.	Title	Page
4-2	Tape Punch Timing Sequence for PA63	4-5
4-3	M710 Punch Control for PA63, Simplified Logic Diagram	4-7
4-4	Tape Reader Timing Sequence for PA68F	4-9
4-5	Tape Punch Timing Sequence for PA68F	4-11
4-6	M710 Punch Control for PA68F, Simplified Logic Diagram	4-12
4-7	G930 Nontorn Tape Alloting Module, Simplified Logic Diagram	4-14
4-8	Punch Motor Control, Simplified Functional Diagram	4-17
4-9	Punch Solenoid Control, Simplified Functional Diagram	4-19
5-1	M401 Reader Clock Adjustment Location	5-2
5-2	Clock Pulse Waveform	5-2
5-3	M710 Punch Control Adjustment Location	5-3
5-4	Punch Done Pulse Waveform	5-3
5-5	PR68B Reader Adjustment Location	5-4
5-6	6-Level Guide and Reader Head Adjustment	5-6
5-7	Reader Lamp and Condensing Lens Adjustment	5-7
5-8	Lateral Adjustment of Sprocket Wheel	5-7
5-9	Axial Adjustment of Sprocket Wheel	5-8
5-10	Spring Arm Adjustment for PR68B	5-8
5-11	Relationship of PR68B Reader Data Pulse and Strobe Pulse for PA63 and PA68F	5-9
5-12	PR68D/DA Reader Adjustment Location	5-10
5-13	Relationship of Data Hole and Photocell for PR68D/DA	5-13
5-14	Spring Arm Adjustment for PR68D/DA	5-14
5-15	Relationship of PR68D/DA Reader Data and Strobe Pulse	5-16
5-16	Punch Solenoid Waveform	5-17
5-17	M302 Dual Delay Multivibrator Module	5-19
5-18	Change Reader Delay Waveform	5-19
5-19	Change Punch Delay Waveform	5-20

TABLES

Table No.	Title	Page
1-1	PA63 Specifications	1-4
1-2	PA68F Specifications	1-4
1-3	PR68B Specifications	1-5
1-4	PR68D/DA Reader Specifications	1-5
1-5	PP67C/D Punch Specifications	1-6
2-1	Reader and Punch Cables	2-2
3-1	Program Instructions	3-1
3-2	PR68B Reader, Control and Indicator	3-3
3-3	PR68D Reader, Control and Indicator	3-4
3-4	PR68DA Reader, Control and Indicator	3-5
3-5	PA63 Reader/Punch Control, Controls and Indicators	3-6
3-6	PP67C/D Punch, Controls	3-8
6-1	Test Equipment and Tools	6-1
6-2	Diagnostic Programs	6-1
6-3	Typesetting Configuration Test Programs	6-2
6-4	System Exerciser Overlays	6-3
6-5	Typesetting Spares	6-4

TABLES (Cont)

Figure No.	Title	Page
6-6	Parts List For PR68B	6-5
B-1	Index of Master Drawing Lists	B-1

FOREWORD

This manual contains maintenance information primarily for use by DEC personnel servicing the Typeset-8 System. The information provided is sufficient for a technician or engineer familiar with the operation, programming, and maintenance of this type of equipment, and presupposes a thorough understanding of DEC logic.

This document covers overall system operation, as well as a detailed logic description of portions of the system unique to typesetting. The major portion of this document describes the operation of the logic circuits that interface the high-speed paper-tape readers and punches with the processor, and the operation of the PR68B and PR68D/DA High-Speed Paper-Tape Readers. The following documents supplement the information contained in this manual.

Title	Document No.
PDP-8E Maintenance Manual	DEC-8E-HR1B-D – DEC-8E-HR3B-D
PDP-8I Maintenance Manual	DEC-8I-HR1A-D
PDP-8L Maintenance Manual	DEC-8L-HR1B-D
DEC Logic Handbook	1969–1972 Editions
Small Computer Handbook	1969–1972 Editions
High-Speed Tape Punch Set, Technical Manual	Teletype [®] Bulletin 215B
High-Speed Tape Punch Set, Parts	Teletype Bulletin 1154B
Motor Units, Technical Manual	Teletype Bulletin 295B
DC04 Wire Service Interface Maintenance Manual	—
LPC-8 On-Line Photocomp Interface Maintenance Manual	—
Typesetting Tech Tips	—

[®] Teletype is a registered trademark of Teletype Corporation.

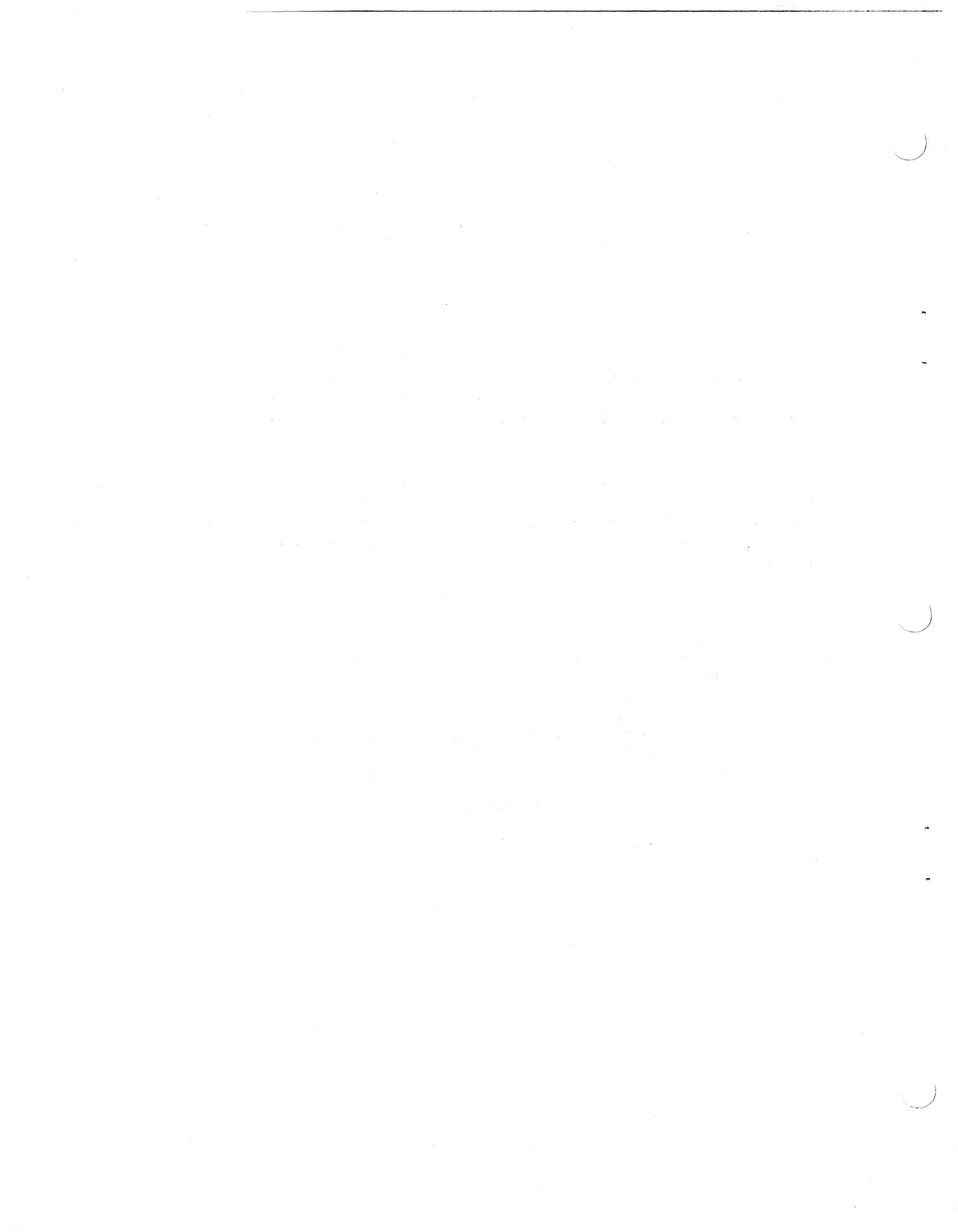

CHAPTER 1

INTRODUCTION

Typeset-8 is a combined software-hardware system that provides high-speed perforated-tape production capability to newspapers, book publishers, and typesetting companies. The system comprises a DEC PDP-8 General-Purpose Computer[†] equipped with a Teletype keyboard, and up to sixteen paper-tape readers and punches (Figure 1-1).

The system converts unjustified, unhyphenated 6- or 8-level perforated paper tape to formatted, justified paper tape. The output tape produced operates hot-metal linecasting machines or photocomposition machines.



Figure 1-1 Typeset-8 System — Positive Logic

[†] Any positive bus PDP-8 computer may be used in negative logic systems.

1.1 SYSTEM DESCRIPTION

The basic Typeset-8 System comprises the following major components, interconnected as shown in Figures 1-2 and 1-3.

- PDP-8E, 8I, 8L Computers
- PA63 Multiple Reader/Punch Control and Interface Unit
- PA68F Reader/Punch Control and Interface Unit
- PR68B High-Speed Paper-Tape Reader
- PR68D High-Speed Paper-Tape Reader
- PR68DA High-Speed Paper-Tape Reader
- PP67C High-Speed Paper-Tape Punch
- PP67D High-Speed Paper-Tape Punch

Multiple reader and punch systems are equipped with the PA63 Reader/Punch Control, and up to 16 sets of readers and punches. The PR68D Readers are used with the PA63 Reader/Punch Control to obtain nontorn tape allotting (NTTA) operation. Single reader and punch systems utilize the PA68F Reader/Punch Control and the PR68B Reader or PR68DA Reader, which are not equipped for NTTA operation.

The basic processor employs a ferrite-core memory with a 4096 12-bit word capacity. This memory serves as an operating area where input data from an unjustified tape is stored and assembled into justified lines. Portions of the memory are also set aside for storage of program instructions and a hyphenating dictionary. Expanded memory options are available to permit the storage of larger dictionaries, if desired. DECTapes and DECdisks are included in the system when hot metal and text photocomposition programs are both used, or when display photocomposition programs are used. These options provide a larger storage capacity and correspondingly higher operating speeds.

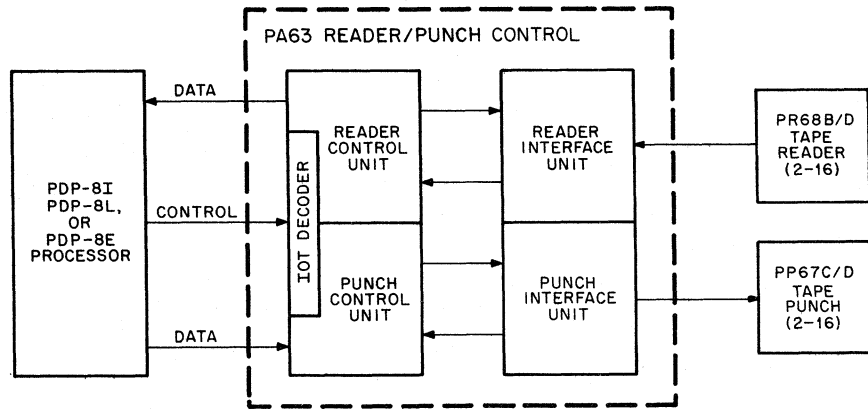

08-0773

Figure 1-2 Multiple Reader/Punch System

A system tape (6-level, binary, perforated paper tape or DECTape) loads these programs and data into memory prior to system use. The system tape also furnishes a glossary of the specific control codes used by the operator to specify the desired type style, type size, column indentions, line length, and special formatting instructions.

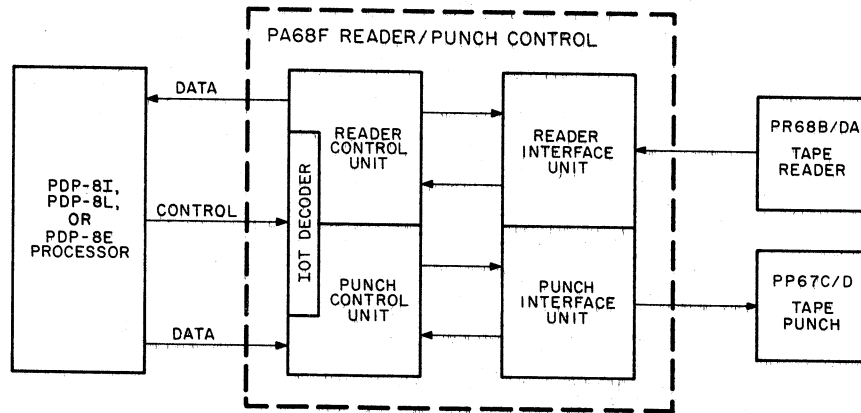

08-0774

Figure 1-3 Single Reader/Punch System

A RIM (Readin Mode) program is set into the processor through the PDP-8 control panel toggle switches. This program loads the system tape. The 6-level RIM Loader is described in full later in this chapter.

Loading the RIM Loader and, subsequently, the system tape prepares the typesetting system for processing input tapes. Operators use keyboard-controlled paper-tape perforators to generate input tapes (unjustified, unhyphenated tapes) from final copy. The input tape contains the material to be typeset, punched in 6- or 8-level codes, without regard for line endings or hyphenation. The operator must include in the initial portion of the input tape the control codes that inform the processor of the type face, type size, and column indention required for the material that follows. Then the material to be typeset is punched onto the tape without regard for line endings.

When the input tape is complete it is placed in a reader and read into the computer. The PDP-8 senses a reader flag output and starts the data transfer process.

The processor assembles the material into lines, as specified by the line-length codes, determines the line-end point, hyphenates and/or inserts additional space codes between words and, if necessary, between letters, and retransmits the data to a punch. This process produces an output tape for hot-metal linecasting or photocomposition machines.

The system simultaneously reads and punches tapes at a rate of 110 characters per second. This provides a throughput corresponding to approximately 12,000 lines per hour. Display copy throughput is slower.

1.2 SPECIFICATIONS

The physical structure, environmental specifications, and power supply requirements of the Typeset-8 System are presented in Tables 1-1 through 1-5.

**Table 1-1
PA63 Specifications**

Specification	Description						
Physical Dimensions							
Height:	8.68 in.						
Width:	19.0 in.						
Depth:	20.75 in.						
Power Requirements	115 Vac \pm 10%, 60 Hz \pm 5%, 30A						
Power Supplies (internal)	<table border="0"> <tr> <td align="center">H721</td> <td align="center">798</td> </tr> <tr> <td align="center">+5V \pm .25V</td> <td align="center">+30V \pm 3V</td> </tr> <tr> <td align="center">-15V \pm 1V</td> <td></td> </tr> </table>	H721	798	+5V \pm .25V	+30V \pm 3V	-15V \pm 1V	
H721	798						
+5V \pm .25V	+30V \pm 3V						
-15V \pm 1V							
Logic Levels	<table border="0"> <tr> <td align="center">Input</td> <td align="center">Output</td> </tr> <tr> <td align="center">+2V to +3.6V</td> <td align="center">+2.4V to +3.6V</td> </tr> <tr> <td align="center">+8V to GND</td> <td align="center">+0.4V to GND</td> </tr> </table>	Input	Output	+2V to +3.6V	+2.4V to +3.6V	+8V to GND	+0.4V to GND
Input	Output						
+2V to +3.6V	+2.4V to +3.6V						
+8V to GND	+0.4V to GND						
Logic 1 (H)							
Logic 0 (L)							
Temperature	20°C to 50°C 68°F to 122°F						
Humidity	20% to 95% without condensation						

**Table 1-2
PA68F Specifications**

Specification	Description						
Physical Dimensions							
Height:	5.19 in.						
Width:	19.00 in.						
Depth:	18.00 in. (including H716 Power Supply)						
Power Requirements	115 Vac, 60 Hz \pm 5%, 20A						
Power Supplies (internal)	<table border="0"> <tr> <td align="center">H716</td> <td align="center">799</td> </tr> <tr> <td align="center">+5V \pm .25V</td> <td align="center">+30V \pm 3V</td> </tr> <tr> <td align="center">-15V \pm 1V</td> <td></td> </tr> </table>	H716	799	+5V \pm .25V	+30V \pm 3V	-15V \pm 1V	
H716	799						
+5V \pm .25V	+30V \pm 3V						
-15V \pm 1V							
Logic Levels	<table border="0"> <tr> <td align="center">Input</td> <td align="center">Output</td> </tr> <tr> <td align="center">+2V to +3.6V</td> <td align="center">+2.4V to +3.6V</td> </tr> <tr> <td align="center">+8V to GND</td> <td align="center">+0.4V to GND</td> </tr> </table>	Input	Output	+2V to +3.6V	+2.4V to +3.6V	+8V to GND	+0.4V to GND
Input	Output						
+2V to +3.6V	+2.4V to +3.6V						
+8V to GND	+0.4V to GND						
Logic 1 (H)							
Logic 0 (L)							
Temperature	20°C to 50°C 68°F to 122°F						
Humidity	20% to 95% without condensation						

**Table 1-3
PR68B Specifications**

Specification	Description
Physical Dimensions	
Height:	6 in.
Width:	8-1/4 in.
Depth:	10-1/4 in.
Weight:	4.5 lb
Tape Characteristics	Refer to the <i>Typeset-8 System User's Guide</i> .
Power Requirements	No external ac power required.
Power Supplies (internal)	DC power is supplied by the reader/ punch control.
Logic Levels	
Logic 1 (H)	+2.4V to 3.6V
Logic 0 (L)	+0.4V to GND
Temperature	12.5°C to 44°C 55°F to 110°F
Humidity	20% to 95% without condensation

**Table 1-4
PR68D/DA Reader Specifications**

Specification	Description
Physical Dimensions	
Height:	7.15 in.
Width:	11 in.
Depth:	8.5 in.
Weight:	4.5 lb
Tape Characteristics	Refer to the <i>Typeset-8 System User's Guide</i> .
Power Requirements	No external ac power required.
Power Supplies (internal)	DC power is supplied by the reader/ punch control.
Logic Levels	
Logic 1 (H)	+2.4V to 3.6V
Logic 0 (L)	+0.4V to GND
Temperature	68°F to 122°F 20°C to 50°C
Humidity	20% to 95% without condensation

Table 1-5
PP67C/D Punch Specifications

Specification	Description
Physical Dimensions	
Height:	12 in.
Width:	8 in.
Depth:	16.5 in.
Weight:	24.5 lb
Tape Characteristics	Refer to the <i>Typeset-8 System User's Guide</i> .
Power Requirements	115V \pm 10%, 50 or 60 Hz \pm 1% at 2A (9A surge)
Power Supplies (internal)	DC power is supplied by the reader/punch control.
Logic Levels	
Logic 1 (H)	GND
Logic 0 (L)	+30V
Temperature	68°F to 122°F 20°C to 50°C
Humidity	20% to 95% without condensation

CHAPTER 2

INSTALLATION

The information contained herein is necessary to install the Positive Logic Typeset-8 System hardware. The systems are completely configured at the factory before being shipped to the customer's site. Once the system is set up, it should be connected to the primary ac power source and the reader and punch cables connected. All dc power supplies and processor bus interface connections are installed at the factory. System add-ons should be installed as directed in the applicable maintenance manual for the processor, peripheral, or terminal being installed.

2.1 CABLING AND TERMINATIONS

The PA63 and the PA68F are connected to the processor bus as described in the applicable processor maintenance manuals. Signals are transmitted from the PA63 and the PA68F to the PR68D/DA through a BC01H Cable that plugs into a connector slot. The BC01H Cable (D-UA-BC01H-0-0) is a 24-conductor cable terminated by an M978 Connector Module (D-CS-M978-0-1) that plugs into the connector slot and an Amphenol connector that plugs into the PR68D/DA. Signals are transmitted from the PA63 and the PA68F through a 70-5893 cable that plugs into a connector slot. The 70-5893 cable is a 24-conductor cable terminated on both ends by an M908 Connector Module.

Signals are transmitted from the PA63 and the PA68F to the PP67C/D through a BC01F Cable (D-UA-BC01F-0-0) that plugs into a connector slot. The BC01F Cable is a 24-conductor cable terminated by an M979 Connector Module (D-CS-M979-0-1) that plugs into the connector slot and an Amphenol connector that plugs into the PP67C/D.

The interface connections and signals are shown in Figures 2-1 through 2-3. Cable types and lengths are listed in Table 2-1.

The M978 module (Figure 2-4) on the reader cable contains bypass capacitors for the +5, +30, and -15 Vdc lines. It also contains a low pass filter and a diode clamp for each data line. The bypass capacitors and filters suppress switching transient noise spikes that could cause false triggering in the control. The diode clamps limit the data levels to -0.7 Vdc minimum and +5.7 Vdc maximum, preventing damage to the M216 modules.

The M979 module (Figure 2-5) on the punch cable contains bypass capacitors for the +5 Vdc line and +30 Vdc switched line. It also contains a low pass filter for each of the data lines. These capacitors and filters suppress transient switching noise spikes that could cause false triggering in the control. Suppressing the noise spikes also compensates for data level degradation due to transmission line loss. Consequently, the punches can use cables of up to 250 feet in length without readjusting the punch solenoids, if the solenoids are properly adjusted. The diodes on the M979 module do not affect the operation of the control.

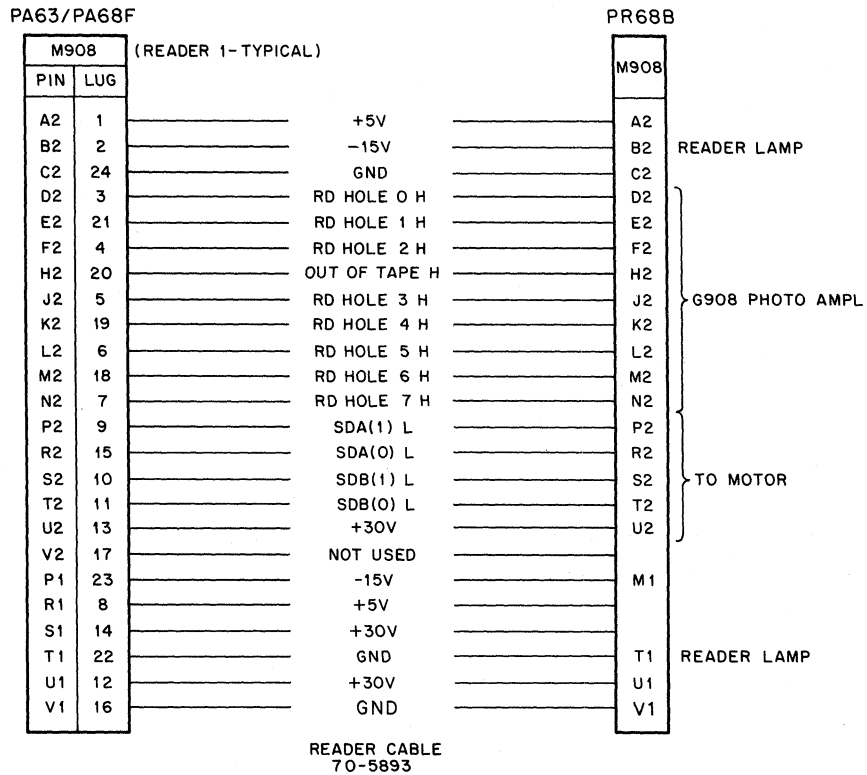

08-0788

Figure 2-1 PR68B Reader/Interface Cable Interconnection

Table 2-1
Reader and Punch Cables

PR68B Reader	Type		Length
	PR68D/DA Reader	PP67C/D Punch	
70-5893	BC01H-25	BC01F-25	25 ft
NOTE	BC01H-50	BC01F-50	50 ft
Cable length	BC01H-75	BC01F-75	75 ft
is specified	BC01H-A0	BC01F-A0	100 ft
in ft. – 250	BC01H-A2	BC01F-A2	120 ft
max.	BC01H-A5	BC01F-A5	150 ft
	BC01H-A7	BC01F-A7	170 ft
	BC01H-B0	BC01F-B0	200 ft
	BC01H-B2	BC01F-B2	220 ft
	BC01H-B5	BC01F-B5	250 ft

PA63/PA68F

PR68D/DA

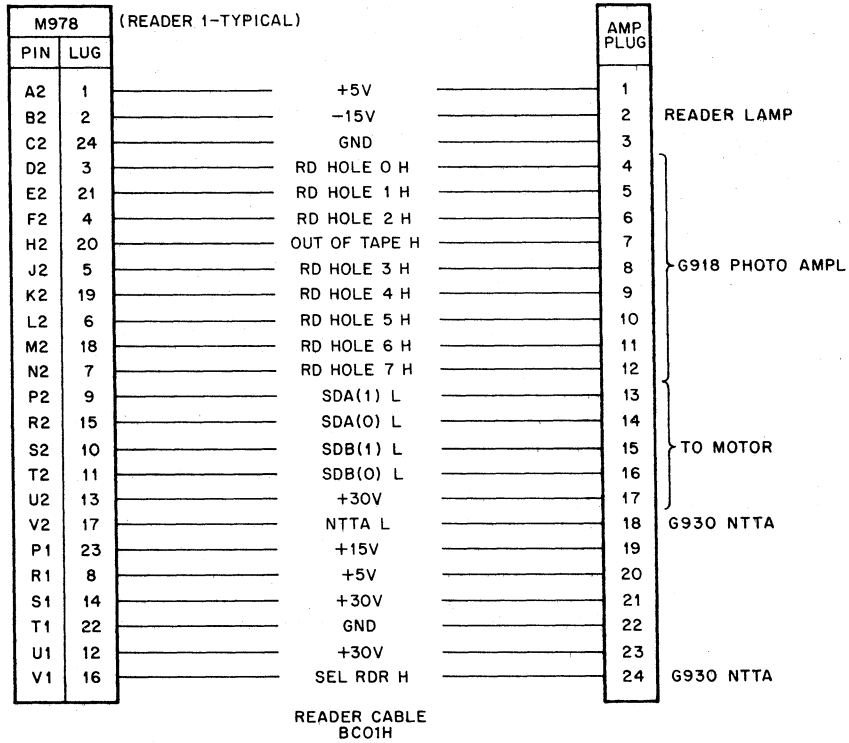

NOTE:
NTTA L is not used on PR68DA.

08-0787

Figure 2-2 PR68D/DA Reader/Interface Cable Interconnection

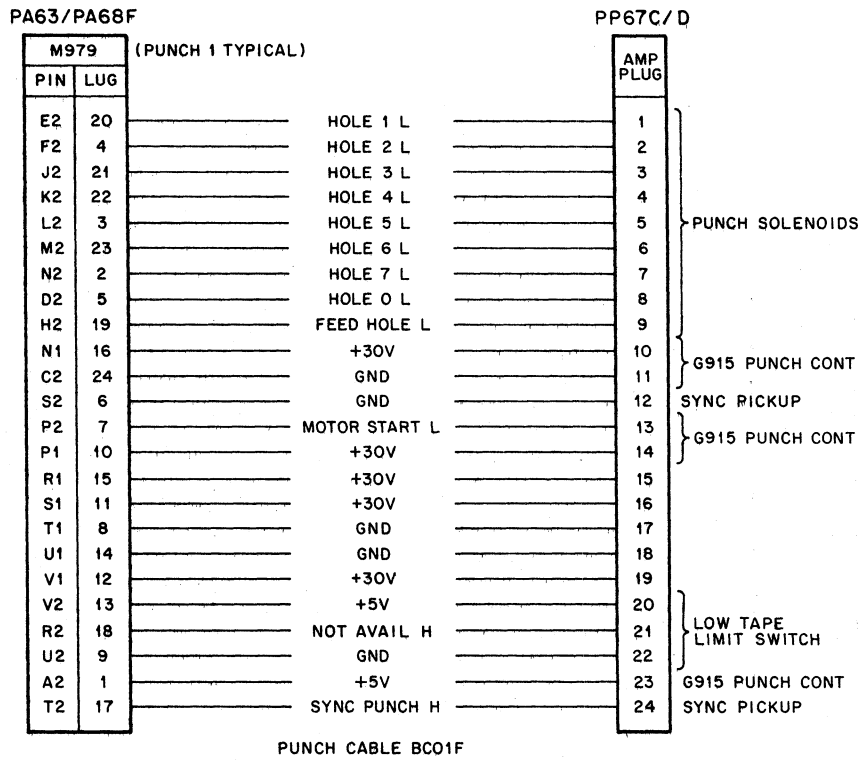

NOTE:
NOT AVAIL H is used on PA68F.

Figure 2-3 PP67C/D Punch/Interface Cable Interconnection

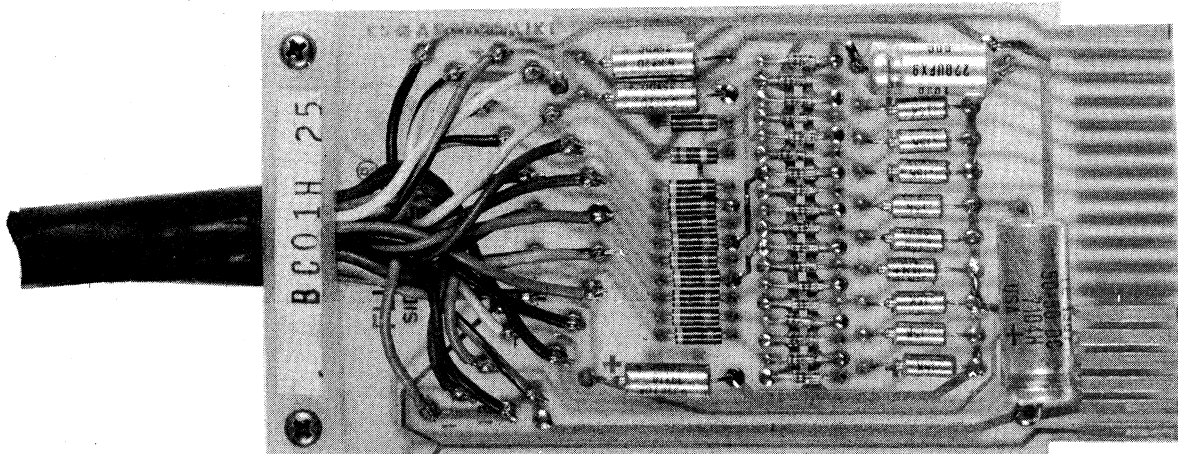

Figure 2-4 M978 Connector Module

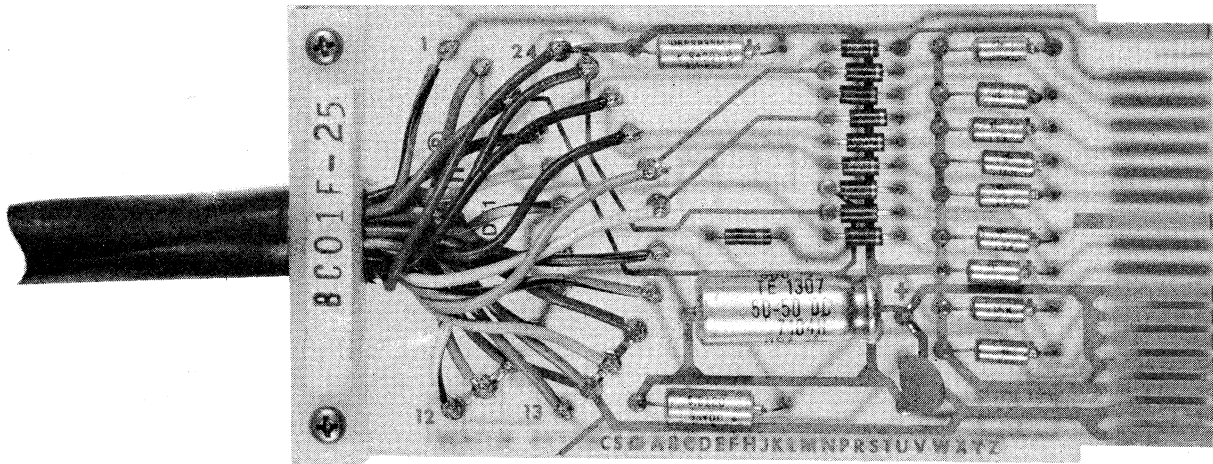

Figure 2-5 M979 Connector Module

2.2 POWER CONNECTIONS

The PA63 and PA68F Controls draw all electrical power from the cabinet in which they are mounted. Power for the PA63 is supplied by the H721 Power Supply and the 798 or 798A Power Supply. Power wiring is shown in PA63-0-16. Power for the PA68F is supplied by the H716 and the 799 or 799A Power Supply. Power wiring is shown in PA63-F-7.

NOTE

Do not mount power supplies directly behind the PA63. Power supplies mounted in this location may interfere with the cables connected to the PA63 and cause damage.

The reader and punch receive all required dc power from the controls. The punch also has an integral power control that is connected to the appropriate ac source through an ac power cable; this cable is supplied with the punch.

NOTE

All hardware that is equipped for 50 Hz power is identified by the suffix A in the type number, e.g., PP67CA.

Primary ac power is routed to the power supplies through an 854 or 854B Power Control. The power controls are connected to the appropriate ac source through an ac power cable. This cable is supplied with the control and is hard-wired to it.

2.3 INSTALLATION VERIFICATION

When all system components have been connected and adjusted, the installation can be verified by running the appropriate Typeset-8 test and exerciser programs (Paragraph 6.1).

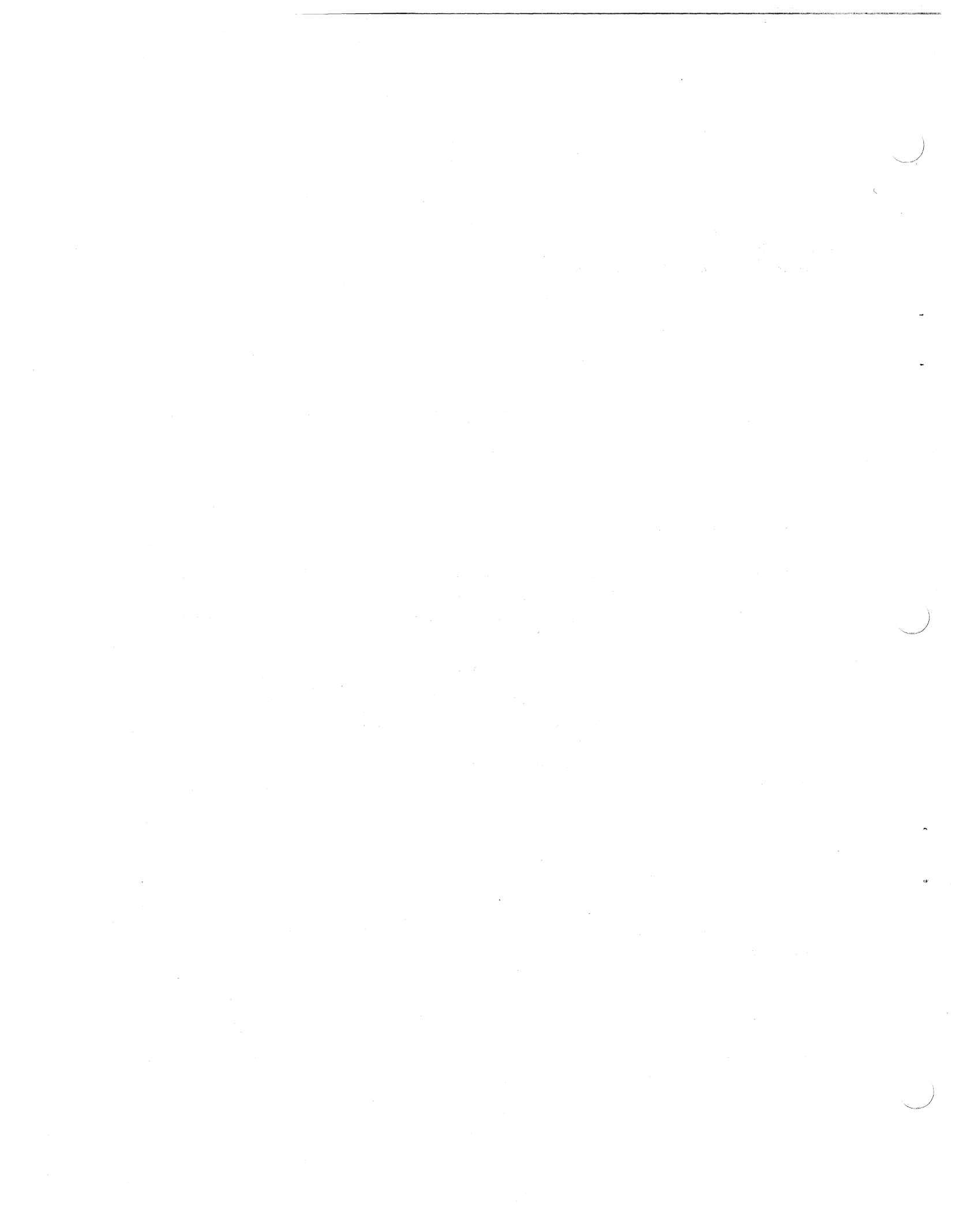

CHAPTER 3

OPERATION AND PROGRAMMING

Typeset-8 System hardware is normally program-controlled. Each Typeset-8 System is preprogrammed to perform specific typesetting tasks for specific customers. Many systems are programmed to perform business applications tasks also. Program instructions for the reader/punch controls are described in Paragraph 3.1.

Readers have manual controls for selection and NTTA operation, and punches have a manual control for availability and tape feed. Reader/punch controls have manual controls for tape level and NTTA modes. These controls are described in Paragraph 3.3.

3.1 PROGRAM INSTRUCTIONS

The system tape differs in each installation because format and type styles differ. For this reason, the customer's own system tape must be used. Loading instructions are given in the applicable *Typeset-8 System User's Guide*.

The program instructions, their mnemonic codes, the IOT pulses generated, and their associated functions are listed in Table 3-1.

Table 3-1
Program Instructions

Mnemonic	Instruction	Function
RSF	6011	Skip if reader flag is a 1.
RRB	6012	Read reader buffer and clear reader flag.
RFC	6014	Clear flag and buffer; fetch and load character.
SKPNA*	6311	Skip on punch not available.
RSC*	6312	Clear and load reader selector.
PSC*	6314	Clear and load punch selector.
PSF	6021	Skip if punch flag is a 1.
PCF	6022	Clear punch flag.
PPC	6024	Load punch buffer and punch character.
PLS	6026	Load punch buffer; clear punch flag and punch character.

*These instructions are not used on the PA68F.

3.2 DATA FORMATS

The paper tape processed by the Typeset-8 System is 7/8-inch wide, 6-channel or 1-inch wide, 8-channel tape. Each byte of data is punched into one frame that consists of up to eight data positions arranged in a line perpendicular to the length of the tape. A hole punched in a data position represents a 1, and a 0 is represented by the absence of a hole.

The data positions are numbered from 0 to 7, with 0 the least significant bit and 7 the most significant bit. The feed hole, which is punched for every frame, is positioned between channels two and three (a channel is composed of one data position in successive frames of tape, i.e., a row of holes and unpunched positions extending the length of the tape). The feed hole may be in-line or advance. Figure 3-1 illustrates the tape formats.

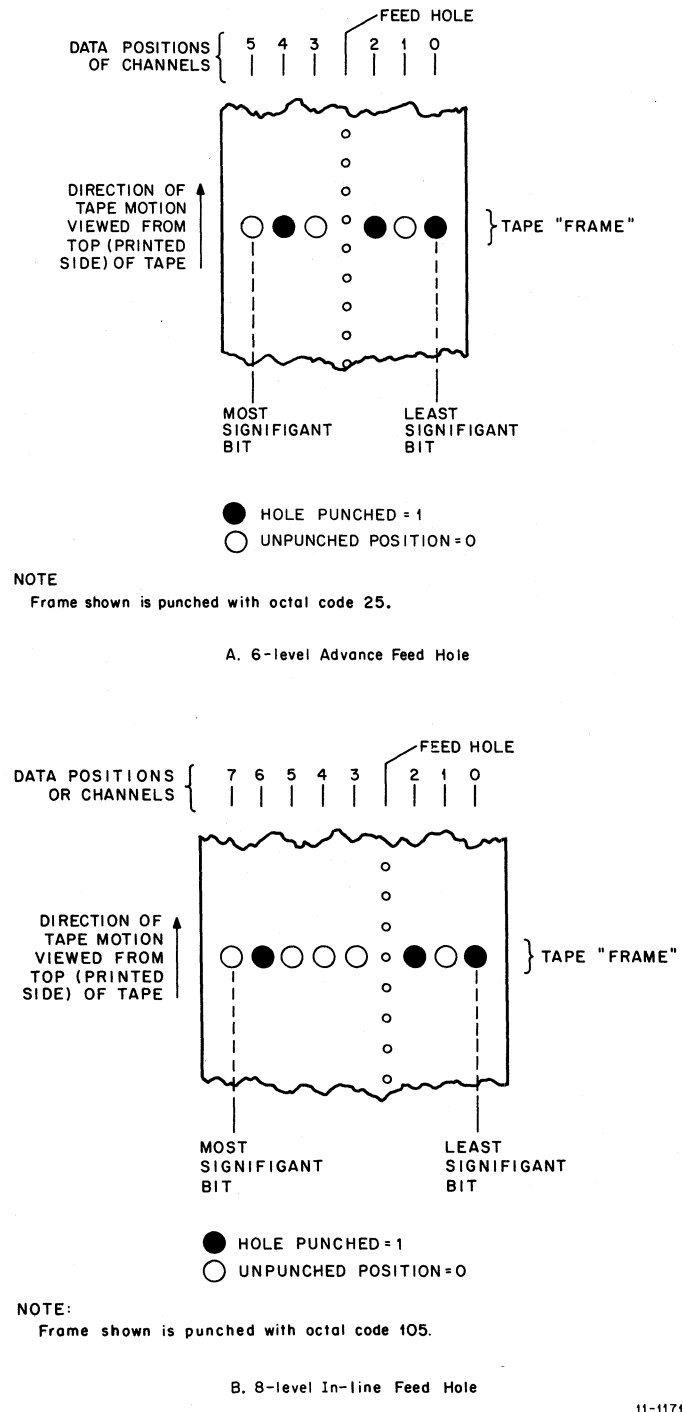

Figure 3-1 Paper-Tape Formats

NOTE

For 6-channel tape, bits 06 and 07 are disabled by a switch on the back of the PR68E.

3.3 CONTROLS AND INDICATORS

3.3.1 PR68B High-Speed Paper-Tape Reader

The control and indicator on the PR68B Reader are shown in Figure 3-2 and described in Table 3-2.

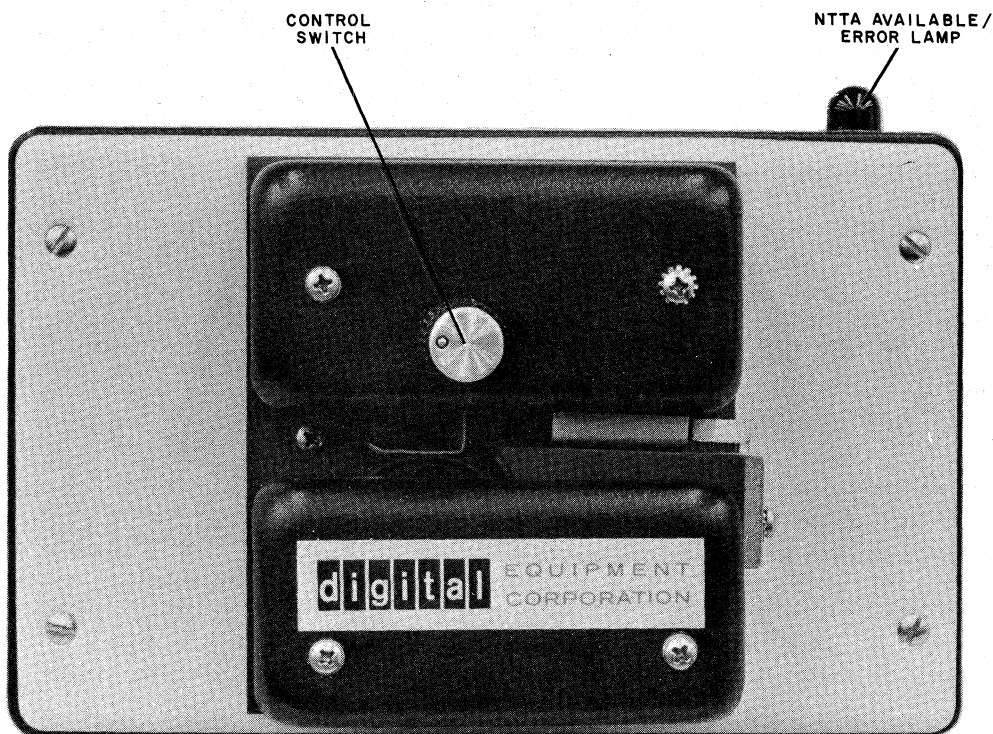

Figure 3-2 PR68B Reader

Table 3-2
PR68B Reader, Control and Indicator

Name	Function
Control Switch	Places the reader under program control. Paper tape must be placed in the reader before the switch is closed. When the switch is closed, the reader is ready for selection (on-line). When the switch is open, the reader is out-of-tape and is not available for selection (off-line).
NTTA Available/Error Lamp	This lamp is not connected in the PR68B. It is only used on the PR68A in negative logic systems equipped for NTTA operation.

3.3.2 PR68D High-Speed Paper-Tape Reader

The control and indicator on the PR68D Reader are shown in Figure 3-3 and described in Table 3-3.

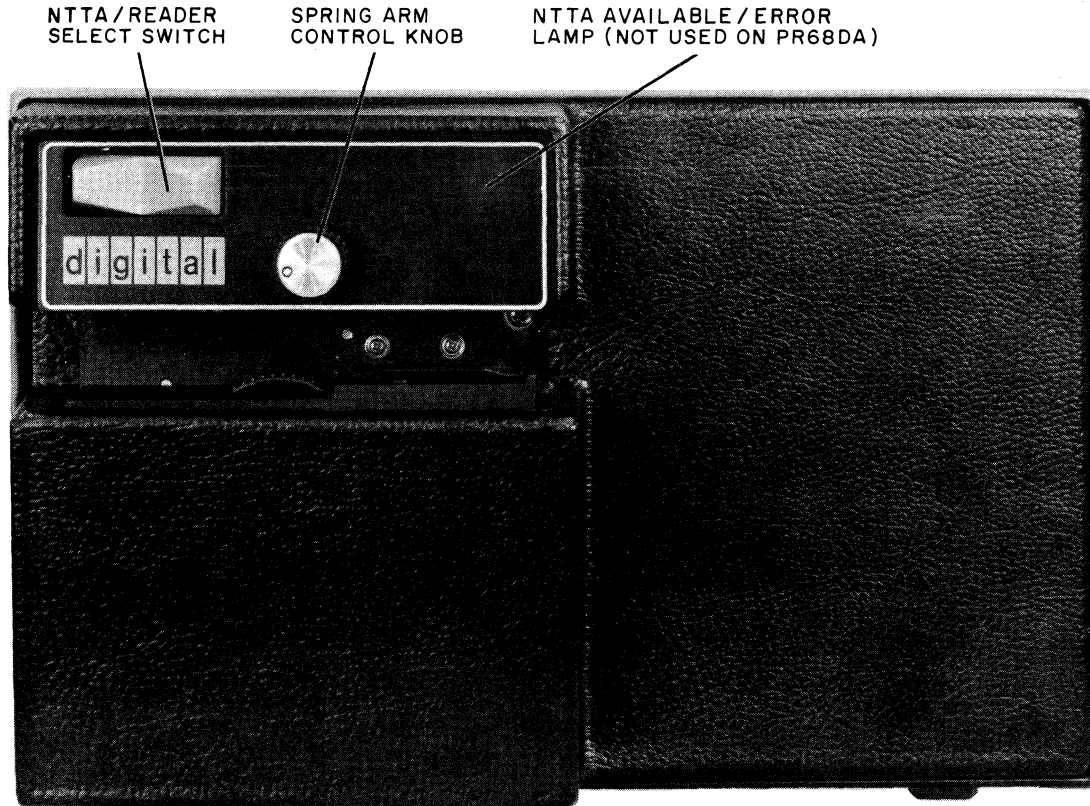

Figure 3-3 PR68D/DA Reader

Table 3-3
PR68D Reader, Control and Indicator

Name	Function
NTTA Reader Select Switch	Places the reader under program control. Paper tape must be placed in the reader before the switch is pressed. Switch returns to normal position when released.
Available/Error Lamp	Indicates the status of the reader. When the light is off, the reader is selected. When the light is on, the reader is deselected. Light goes on and reader deselected when the end of the take is read. If the NTTA Reader Select Switch is pressed when there is no tape in the reader, the lamp goes off and then lights when the reader is polled by the program.

3.3.3 PR68DA High-Speed Paper-Tape Reader

The control and indicator on the PR68DA Reader are shown in Figure 3-3 and described in Table 3-4.

Table 3-4
PR68DA Reader, Control and Indicator

Name	Function
Reader Select Switch	Places the reader under program control. When the switch is depressed to the left, the reader is selected (on-line). When the switch is depressed to the right, the reader is deselected (off-line). To restart the reader after it has been deselected, by pressing the switch to the right, the typesetting program must be restarted.
NTTA Available/Error Lamp	This lamp is not connected in the PR68DA. Refer to Table 3-3.

3.3.4 PA63 Multiple Reader/Punch Control and Interface Unit

There are two manual controls on the PA63 Reader/Punch Control, located below the top cover on the left-hand side of the unit. The indicators on the PA63 are shown in Figure 3-4. The indicators and the controls are described in Table 3-5.

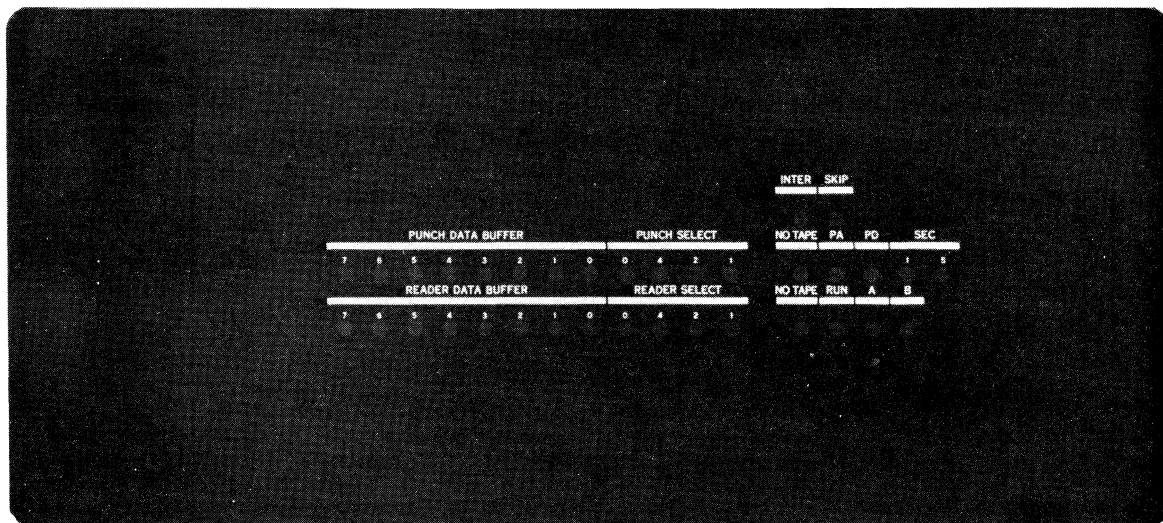

Figure 3-4 PA63 Multiple Reader/Punch Control

Table 3-5
PA63 Reader/Punch Control, Controls and Indicators

Name	Function
6/8 LEVEL SWITCH	Places the control in the 6- or 8-level tape reading mode. This switch must be set to the position that corresponds to setting of the tape level slide on the reader and the level of the tape being read.
PUNCH DATA BUFFER	Displays the contents of the punch buffer register. Corresponding lamp is dimly lit when a bit is set.
PUNCH SELECT	Displays the octal number of the last punch selected.
NO TAPE (punch)	Lights when currently selected punch is out-of-tape, i.e., tape supply is below the setting of the tape low switch on the punch.
PA (punch active)	Displays the state of the punch control. Lamp is lit when the punch is active (on) and off when the punch is done (off).
PD (punch done)	Displays the state of the punch control. Lamp is lit when the punch is done (off) and off when the punch is active (on).
1 SEC	Displays 1-second speed delay. Lamp is lit until delay times out, and punch is up to speed and off when the punch starts perforating tape.
5 SEC	Displays 5-second delay. Lamp is lit until punch motor starts and off when the punch starts to run.
READER DATA BUFFER	Displays the contents of the reader buffer register. Corresponding lamp is lit when a bit is set.
READER SELECT	Displays the octal number of the last reader selected.
NO TAPE (reader)	Lights when there is no tape in the reader or it is stopped. Lamp is dimly lit when it is running with the tape in it.
RUN	Displays the state of the reader control. Lamp is off when the reader is not running and lit when the reader is running.
A/B	Display the state of the A and B flip-flops in the reader control. Corresponding lamp is lit when the reader is not running and dims when the reader is running.
INTER	Displays the state of the interrupt bit. Lamp is lit during an interrupt request.
SKIP	Displays the state of the skip bit. Lamp is lit during a skip.
NTTA ON/OFF	Places the control in the NTTA mode. This switch must be set to ON during normal operation. It may be set to OFF when running the TSCE program, making maintenance checks, or using PR68DA Readers.

3.3.5 PP67C/D High-Speed Paper-Tape Punch

The controls on the PP67C/D Punch are shown in Figure 3-5 and described in Table 3-6.

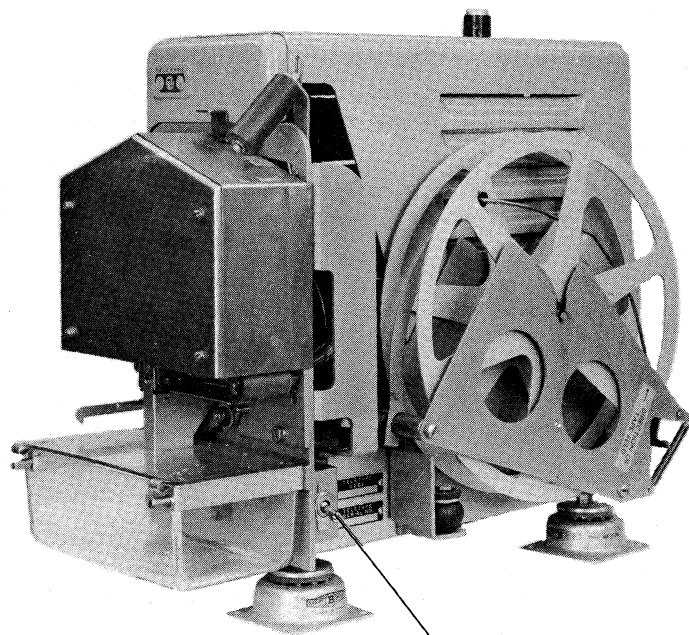

ON/OFF SWITCH

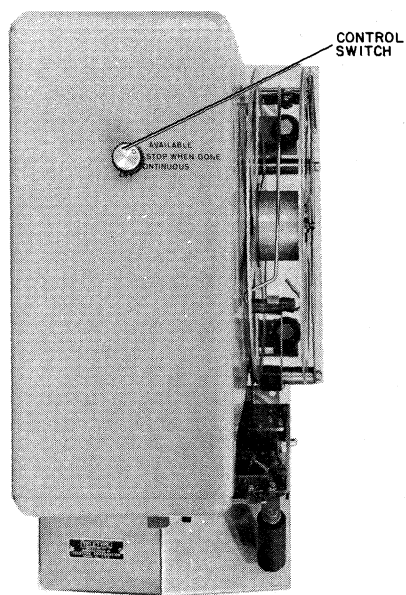

CONTROL SWITCH

Figure 3-5 PP67C/D Punch Controls

**Table 3-6
PP67C/D Punch, Controls**

Name	Function
Control Switch	
AVAILABLE	Places the punch under program control. An adjustable microswitch located on the side of the punch monitors the level of the tape supply. The microswitch is operated by an arm that rests on the tape spool. When the spool is reduced to a predetermined diameter (determined by the setting of the microswitch), the switch closes, sending a PUNCH NOT AVAILABLE to the PA63 or the PA68F.
STOP WHEN DONE	Simulates a "low tape" condition. Punch can be removed from service before the tape supply gets too low to complete another take, without interrupting the current take.
CONTINUOUS	Places the punch under manual control. Motor runs but a PUNCH NOT AVAILABLE signal is sent to the PA63 or the PA68F, preventing programmed selection of the punch.
OFF	Turns the punch motor off by disabling the motor control circuit. A PUNCH NOT AVAILABLE signal is sent to the PA63, preventing programmed selection of the punch.

NOTE

The ON/OFF switch on the side of the punch can be used to turn the punch motor on and off during maintenance. Customers should be advised not to use this switch while replacing tape because a take could be routed to the punch and lost if the control switch is left in the AVAILABLE position while the tape is being replaced.

CHAPTER 4

THEORY OF OPERATION

This section contains detailed information on the theory of operation of the positive logic hardware used in the Typeset-8 Systems. The information presented in this section is directed toward DEC-trained maintenance personnel and is intended to ensure a complete understanding of all operating characteristics of the system. It also permits on-site maintenance of typesetting systems by maintenance personnel, who are qualified to service the processors, but have not been formally trained in the operation, theory, and maintenance of Typeset-8 Systems.

The engineering drawings in Volume II of this manual represent the latest revisions available at the time of printing. However, Typeset-8 Systems are continually being changed and upgraded to satisfy specific customer requirements. Therefore, these drawings and the detailed theory description contained in this manual should be used only as a guide to understanding system operation. For troubleshooting and repairing a specific system installation, use the on-site engineering drawings, and call Maynard often.

4.1 PA63 MULTIPLE READER/PUNCH CONTROL AND INTERFACE UNIT

The PA63 Multiple Reader/Punch Control and Interface Unit is a controller and interface for the positive logic processors in the PDP-8 series. Up to 16 readers and punches can be interfaced to the unit. One reader and one punch can be selected at a time.

The reader control turns the stepping motor in the selected reader on and off as directed by the processor and the program. It also buffers the data after directing the selected reader to fetch a character.

The punch control turns the ac motor in the selected punch on and off and energizes the punch solenoids as directed by the processor and the program. It also buffers the data after it is transferred from the processor.

The logic and circuit diagrams for the PA63 are listed in the Master Drawing List:

Drawing No.	Title
A-ML-PA63-0	16-Channel Reader/Punch Multiplexer

The PA63 is housed in a standard H925 module drawer that has 36 H803 mounting blocks. The module drawer is mounted using chassis tracks. The PA63 contains 52 integrated circuit modules when two readers and two punches are connected. Additional M060 Solenoid Drivers are added as required when more readers are connected to the system.

4.1.1 Power Up

An INITIALIZE pulse is generated in the processor when the power is turned on and also when the START key (CLEAR/CONT) is pressed. In the reader control, this pulse clears:

- a. reader selection register flip-flops (RSB0, RSB1, RSB2 and RSB4) (PA63-0-04)
- b. RUN flip-flop (PA63-0-09)
- c. FLAG flip-flop

In the punch control, this pulse clears:

- a. punch selection register flip-flops (PSB0, PSB1, PSB2 and PSB4) (PA63-0-03)
- b. PUNCH ACTIVE flip-flop (PA63-0-08)
- c. FLAG flip-flop

4.1.2 IOT Decoder for Reader Control

The reader control uses the I/O instructions listed in Table 3-1. Device coding is done in the M111, M113, and M119 modules (PA63-0-07). Device code 31 (BMB 03-08) is gated with IOP 2 H to produce IOT 6312. Device code 01 (BMB 03-08) is gated with IOP 1 H, IOP 2 H, and IOP 4 H to produce IOT 6011, IOT 6012, and IOT 6014. These pulses initiate the specified functions in the reader control.

The sequence of instructions that follows selects reader 0, fetches one character from the paper tape, and transfers it to the processor.

0200/6312	RSC
6014	RFC
6011	RSF
5202	JMP.-1
6012	RRB

The following descriptions are based on this program; the timing sequence is shown in Figure 4-1.

4.1.3 Reader Selection

Reader selection is controlled by the reader selection register flip-flops in M216 (RSB0, RSB1, RSB2 and RSB4), which are set according to the current contents of the AC. IOT 6312 H clocks the reader selection code (BAC 08 (1) H – BAC 11 (1) H) from the AC into the flip-flops (PA63-0-04). The outputs of RSB1, RSB2, and RSB4 are decoded by two M161 binary-to-decimal decoders, one for each group of eight reader selection signals (SEL RDR 00 H – SEL RDR 07 H and SEL RDR 08 H – SEL RDR 15 H). The output of RSB0 selects the appropriate decoder.

Gating the decoded SEL RDR XX H with the outputs of the A and B flip-flops in M113/M060 (PA63-0-05) produces the drive pulses to run the stepping motor of the selected reader. However, input data is not transferred from the photoamplifiers in the selected reader unless a SEL RDR XX H signal is applied to the reader matrix in M141 (PA63-0-10), signifying that the reader is on-line and ready for selection. A SEL RDR XX H signal is generated by a reader when the NTTA/Reader Select switch is depressed.

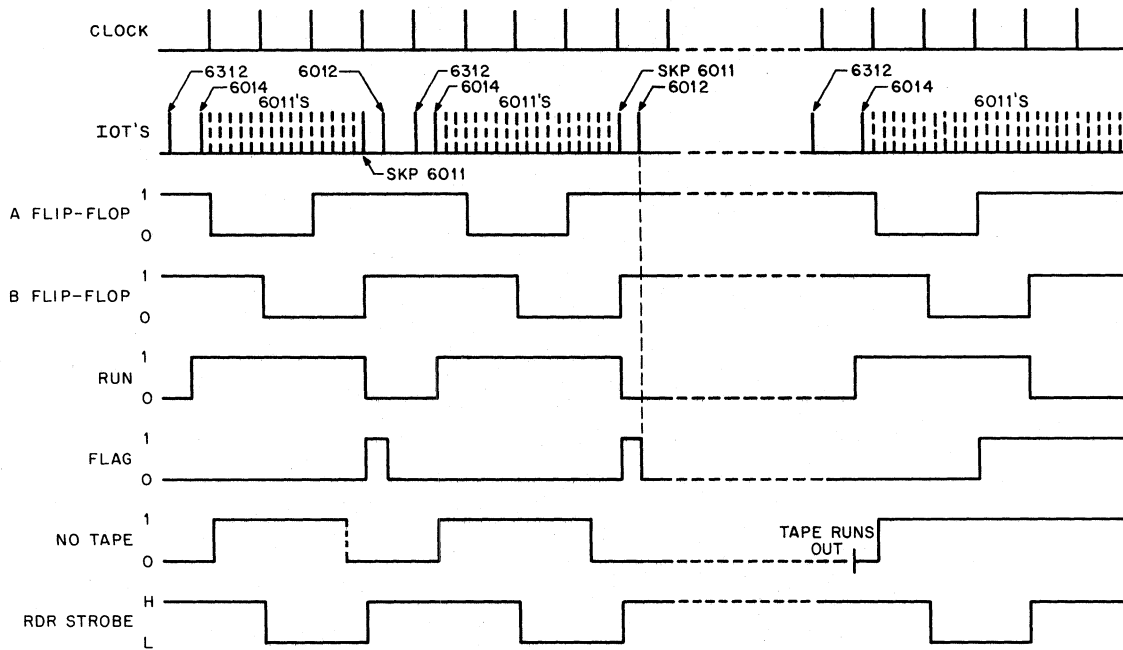

NOTE:
Timing diagram is not drawn to scale.

08-0783

Figure 4-1 Tape Reader Timing Sequence for PA63

Moreover, the SEL RDR XX H signal from the selected reader is also gated with the O. T. XX H signal from the feed hole amplifier. The resultant OUT OF TAPE L is applied to the NO TAPE flip-flop, ensuring that the reader will not be read unless it is on-line and has tape in it (Paragraph 4.4.3).

During reader selection IOT 6312 L triggers a 4 ms delay in M302 (PA63-0-09), disables clock M401 which prevents the clock from switching the A and B flip-flops while changing readers. After the delay times out the clock starts running.

4.1.4 Tape Reading

Gating IOP 4 H with device code 01 [BMB 03 (0) – BMB 07 (0) and BMB 08 (1)] in M103 (PA63-0-09) produces IOT 6014 L. This pulse:

- clears the FLAG flip-flop;
- clears the reader buffer register flip-flops (RB00 to RB07);
- sets the RUN flip-flop;
- sets the NO TAPE flip-flop.

The read cycle is controlled by the RUN flip-flop. Initially, the RUN (1) L output holds the A flip-flop set, preventing the output of Clock M401 from switching the A and B flip-flops until IOT 6014 L arrives. The A flip-flop holds the B flip-flop set.

After the RUN flip-flop is set, the switching sequence is:

	A	B
STATIC	1	1

DYNAMIC	0	1
	0	0
	1	0
	1	1

Four pulses are generated during each cycle. Switching the A flip-flop to a 0 produces the first pulse to the gates and drivers in M113/M060. This pulse moves the frame in the tape over the photocells in the read head. Switching the B flip-flop to a 0 produces the second pulse.

Gating this pulse [B (0) H] with RUN (1) H in M115 produces a RDR STROBE pulse. READER STROBE H clocks the input data from data selection matrix M141 into the reader buffer register flip-flops, loading the buffer while the holes are still over the photocells. A high data input (no hole) sets the corresponding flip-flop. Thus, the current character is fetched from the tape and loaded into the buffer.

Switching the A flip-flop to a 1 again produces the third pulse to the gates and drivers in M113/M060. Switching the B flip-flop to a 1 produces the fourth pulse, B (0) L. This pulse disqualifies the gate in M115 that produces RDR STROBE. The resulting positive transition (\sim RDR STROBE L) clears the RUN flip-flop because the data input is grounded and the direct clear input is connected to +3 Vdc. The RUN (1) L output holds the A flip-flop set.

RUN (0) H attempts to set the FLAG flip-flop. As the feed hole in the tape passes over the photocell, the resulting positive transition (\sim OUT OF TAPE L) clears the NO TAPE flip-flop, allowing RUN (0) H to set the flag. When the reader runs out of tape, the positive transition does not occur and the NO TAPE flip-flop remains set because the data input is grounded and the direct clear input is connected to +3 Vdc. Consequently, the FLAG flip-flop can only be set when there is tape in the reader and the reader is on-line.

This condition is tested by the 6011 instruction. During the read cycle, the processor generates a series of IOP 1 H pulses. Gating these pulses with device code 01 in M103 produces IOT 6011 L pulses. These pulses are in turn gated with FLAG (1) L in M624 to produce a SKIP BUS L pulse if the flag is set. The IOT 6011 L pulse that causes the SKIP BUS L pulse may occur coincident with the setting of the FLAG flip-flop or it may occur after the FLAG flip-flop is set. When the SKIP BUS L pulse occurs, the processor skips the 5202 instruction and executes the 6012 instruction.

FLAG (1) L also produces an unconditional interrupt request (INT RQST BUS L). This signal may be used instead of the 6011 instruction to initiate the transfer of data from the buffer to the processor.

Gating IOP 2 H with device code 01 produces an IOT 6012 L pulse. This pulse:

1. clears the FLAG flip-flop, and
2. gates the contents of the reader buffer to the processor.

Thus, the current character is transferred from the buffer to the processor. A low input from a cleared flip-flop causes the corresponding gate to produce a low output. As a result, the holes in the input tape are translated to 1s.

4.1.5 IOT Decoder for Punch Control

The punch control uses the I/O instructions listed in Table 3-1. Device decoding takes place in the M111, M113, M119, and M710 modules. Device code 31 (BMB 03-08) is gated with IOP 1 H and IOP 4 H to produce IOT 6311 and IOT 6314 (PA63-0-07). Device code 02 (BMB 03-08) is gated with BIOP 1 H, BIOP 2 H, and BIOP 4 H (PA63-0-08) to produce IOT 6021, IOT 6022, and IOT 6024. These pulses initiate the specified functions in the punch control.

The sequence of instructions that follows selects punch 0, checks that the punch is available, transfers one byte of data from the processor, and punches it in the paper tape. If the punch is not available a halt occurs.

0200/6314	PSC
6314	SKPNA
7410	SKP
7402	HLT
6022	PCF
6024	PPC
6021	PSF
5202	JMP.-1

The following logic descriptions are based on this program. The timing sequence is shown in Figure 4-2.

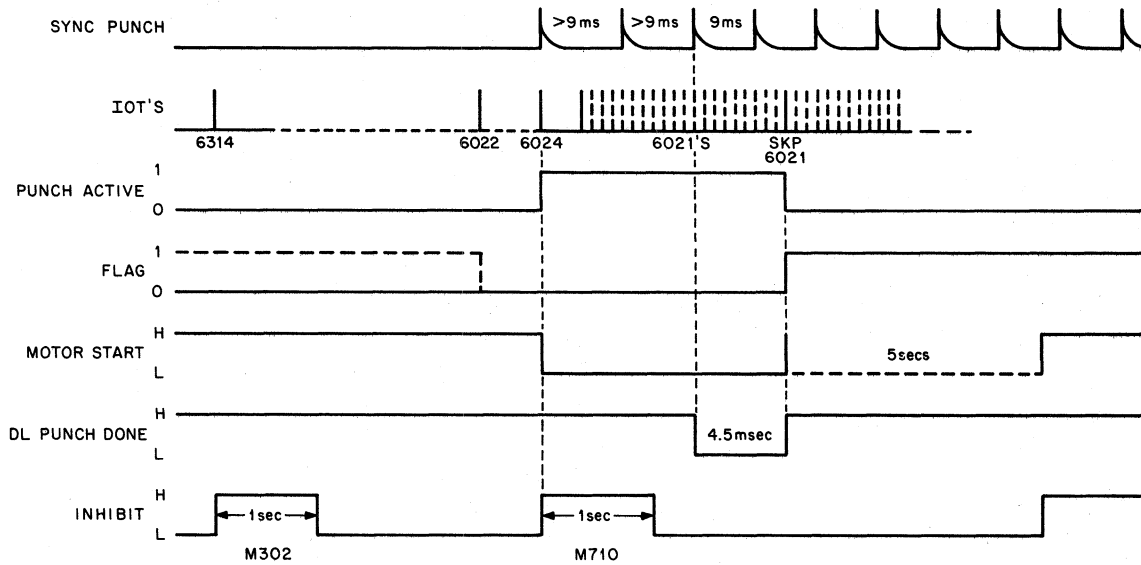

NOTE:
Timing diagram is not drawn to scale.

08-0785

Figure 4-2 Tape Punch Timing Sequence for PA63

4.1.6 Punch Selection

Punch selection is controlled by the punch selection buffer register flip-flops (PSB0 – PSB4) in M216, which are set according to the current contents of the AC. IOT 6314 H clocks the punch selection code (BAC 08 (1) H – BAC 11 (1) H) from the AC into the flip-flops (PA63-0-03).

The outputs of flip-flops PSB1 – PSB4 are decoded by two M161 binary-to-decimal decoders, one for each group of eight punch selection signals (SEL 00 H – SEL 07 H and SEL 08 H – SEL 15 H). The output of flip-flop PSB0 selects the appropriate decoder.

Gating the decoded SEL XX L with MOTOR START L in M623/624 produces MOTOR START XX L for the selected punch. MOTOR START XX L turns on the punch motor and the SCR that supplies +30 Vdc for the solenoids of the selected punch by grounding the motor control circuit punch control G915 (Paragraph 4.1.7). However, MOTOR START L is not produced until the 6024 instruction is executed.

IOT 6314 L triggers a 1-second delay in M302 (PA63-0-08) that interrupts the INHIBIT L input to the SYNC flip-flop. Thus, SYNC PUNCH pulses from the selected punch cannot trigger the 4.5 ms pulse shaper while switching between punches to allow the selected punch to get up to speed.

The availability of the selected punch is checked by gating SEL XX H with NOT AVAIL XX H in M141. If the control switch on the punch is not in the AVAILABLE position or the tape supply is low (below the setting of the low tape limit switch), NOT AVAIL XX H and SEL XX H produce a low input to M623. This condition is tested by the 6311 instruction. Gating IOP 1 with device code 31 in M113/M111 produces IOT 6311 L. Gating this IOT in M623 with the low input from M141 produces SKIP BUS L. This pulse causes the processor to skip the next instruction and halt.

When the control switch on the selected punch is in the AVAILABLE position and the punch has sufficient tape, the SKIP BUS L pulse is not produced and the processor executes the 6022 instruction.

4.1.7 Tape Punching

Gating BIOP 2 with device code 02 [BMB 03 (0) – BMB 06 (0), BMB 07 (1) and BMB 08 (0)] in M710 (PA63-0-08) produces an IOT 6022 L pulse. This pulse clears:

- a. the PUNCH ACTIVE flip-flop;
- b. the PUNCH FLAG flip-flop.

The next instruction (6024) starts the punching cycle. The device code from M119 produces an AC STROBE H pulse, which gates the data [BAC 4 (1) – BAC 11 (1)] from the processor through M101/M111 to the punch buffer.

Gating device code 02 with BIOP 4 in M710 produces an IOT 6024 pulse. IOT 6024 (A) H clocks data into punch buffer register flip-flops PB-0 through PB-3. IOT 6024 (B) H clocks data into punch buffer register flip-flops PB-4 through PB-7. A high data input sets the corresponding flip-flop. IOT 6024 L sets the PUNCH ACTIVE flip-flop.

When the SKIP BUS L pulse occurs, the processor skips the 5202 instruction. FLAG (1) H also produces an unconditional interrupt request (INT RQST BUS L). This signal may be used instead of the 6011 instruction to terminate the punching cycle. If another IOT 6024 L pulse is not generated within 5 seconds, the delay in M710 times out, turning the punch motor off and clearing the 1-second flip-flop.

4.2 PA68F SINGLE READER/PUNCH CONTROL AND INTERFACE UNIT

The PA68F is a controller and interface for the positive logic processors in the PDP-8 series. The reader control turns the stepping motor in the selected reader on and off as directed by the processor and the program. It also buffers the data after directing the selected reader to fetch a character.

The punch control turns the ac motor in the selected punch on and off and energizes the punch solenoids as directed by the processor and the program. It also buffers the data after it is transferred from the processor.

The logic and circuit diagrams for the PA68F are listed in the Master Drawing List:

Drawing No.	Title
A-ML-PA63-0	Reader and Punch Control

The PA68F is housed in a modified H911 Mounting Panel that has six H803 Mounting blocks instead of eight. An H716 Power Supply is mounted on the H911 in the slot where the two mounting blocks were removed. The PA68F contains 17 integrated circuit modules.

4.2.1 Power Up

An INITIALIZE pulse is generated in the processor when power is turned on and also when the START (CLEAR/CONT) key is pressed. In the reader control, this pulse:

- a. disables clock M401, preventing a tape feed cycle if the RUN flip-flop is set;
- b. clears the RUN flip-flop;
- c. clears the FLAG flip-flop.

In the punch control, this pulse clears:

- a. the PUNCH ACTIVE flip-flop;
- b. the PUNCH FLAG flip-flop.

4.2.2 IOT Decoder for Reader Control

The reader control (PA68F-1) uses the I/O instructions listed in Table 3-1. Device decoding takes place in the M103 module. Device code 01 (BMB 03-08) is gated with IOP 1, IOP 2 and IOP 3 to produce IOT 6011, IOT 6012 and IOT 6014. These pulses initiate the specified functions in the reader control.

The sequence of instructions that follows fetches one character from the paper tape and transfers it to the processor.

0200/6014	RFC
6011	RSF
5202	JMP.-1
6012	RRB

The following logic descriptions are based on this program. The timing sequence is shown in Figure 4-4.

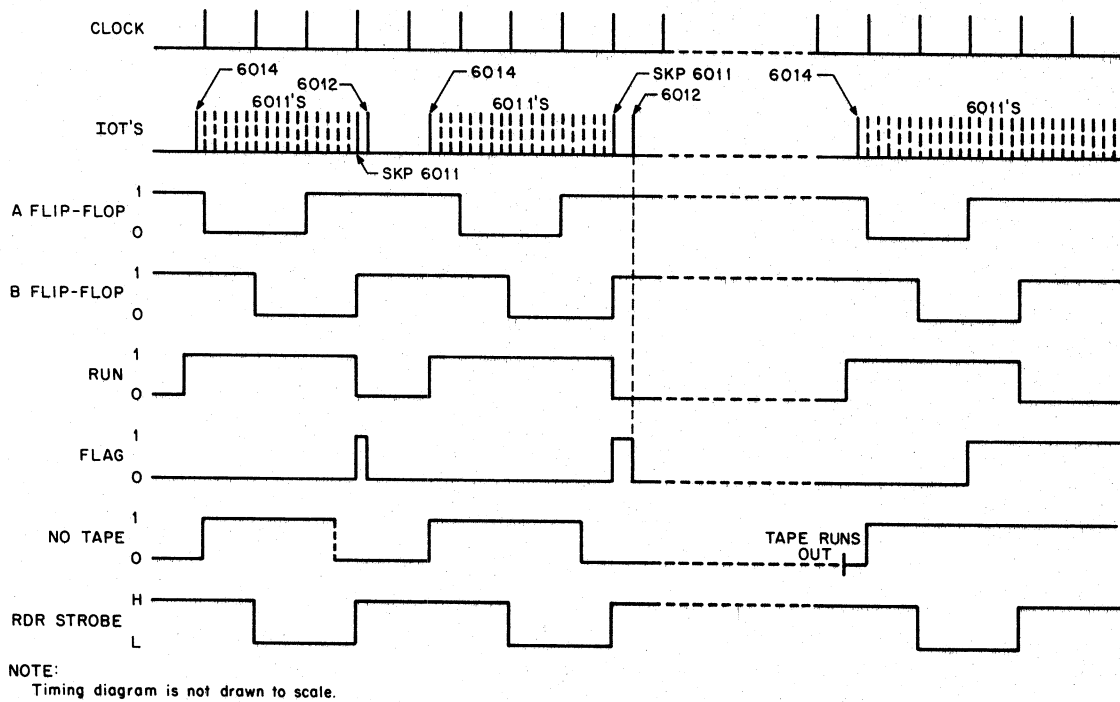

Figure 4-4 Tape Reader Timing Sequence for PA68F

4.2.3 Tape Reading

Gating IOP 4 H with device code 01 [BMB 03 (0) – BMB 07 (0) and BMB 08 (1)] in M103 produces IOT 6014 L. This pulse:

- a. clears the FLAG flip-flop;
- b. clears the reader buffer register flip-flops (RB00 to RB07);
- c. sets the RUN flip-flop;
- d. sets the NO TAPE flip-flop.

The read cycle is controlled by the RUN flip-flop. Initially, the RUN (1) H output holds the A flip-flop set, preventing the output of Clock M401 from switching the A and B flip-flops until IOT 6014 L arrives. A flip-flop holds the B flip-flop set.

After the RUN flip-flop is set, the switching sequence is:

	A	B
STATIC	1	1

DYNAMIC	0	1
	0	0
	1	0
	1	1

Four pulses are generated during each cycle. Switching the A flip-flop to a 0 produces the first pulse to the gate and driver in M113/M060. This pulse moves the frame in the tape over the photocells in the read head.

Switching the B flip-flop to a 0 produces the second pulse. Gating this pulse [B.(0) H] with RUN (1) H in M115 produces a RDR STROBE pulse. READER STROBE H clocks the input data from the photoamplifiers in the reader into the buffer register flip-flops, loading the buffer while the holes are still over the photocells. A high data input (hole) sets the corresponding flip-flop. Thus, the current character is fetched from the tape and loaded into the buffer.

Switching the A flip-flop to a 1 produces the third pulse to the gate and driver in M113/M060. Switching the B flip-flop to a 1 produces the fourth pulse, B (0) L. This pulse disqualifies the gate in M115 that produces RDR STROBE. The resulting positive transition (\sim RDR STROBE L) clears the RUN flip-flop because the data input is grounded. RUN (1) H holds the A flip-flop set. The four pulses generated by the A/B flip-flops are inhibited by \sim SEL RDR H when the reader is deselected. This keeps the motor in the reader turned off when it is deselected so that it does not overheat.

RUN (0) H attempts to set the FLAG flip-flop. As the feed hole in the tape passes over the photocell, the resulting positive transition (\sim OUT OF TAPE L) clears the NO TAPE flip-flop, allowing RUN (0) H to set the flag. When the reader runs out of tape or is deselected, the positive transition does not occur and the NO TAPE flip-flop remains set. Consequently, the FLAG flip-flop can only be set when there is tape in the reader and the reader is on-line.

This condition is tested by the 6011 instruction. During the read cycle, the processor generates a series of IOP 1 H pulses. Gating these pulses with device code 01 in M103 produces IOT 6011 L pulses. These pulses are gated with FLAG (0) H in M623 to produce a SKIP BUS L pulse if the flag is set. The IOT 6011 L pulse that causes the SKIP BUS L pulse may occur coincident with the setting of the FLAG flip-flop or it may occur after the FLAG flip-flop is set. When the SKIP BUS L pulse occurs, the processor skips the 5202 instruction and executes the 6012 instruction.

FLAG (0) H also produces an unconditional interrupt request (INT RQST BUS L). This signal may be used instead of the 6011 instruction to initiate the transfer of data from the buffer to the processor.

Gating IOP 2 H with device code 01 produces an IOT 6012 L pulse. This pulse:

1. clears the FLAG flip-flop,
2. gates the contents of the reader buffer to the processor.

Thus, the current character is transferred from the buffer to processor. A low input from a set flip-flop causes the corresponding gate to produce a low output. As a result, the holes in the input tape are translated to 1s.

4.2.4 IOT Decoder for Punch Control

The punch control (PA68F-2) uses the I/O instructions listed in Table 3-1. Device decoding takes place in the M113, M119, and M710 modules. Device code 02 (BMB 03-08) is gated with IOP 1 H, IOP 2 H and IOP 4 H to produce IOT 6021, IOT 6022, and IOT 6024. These pulses initiate the specified functions in the punch control.

The sequence of instructions that follows transfers one byte of data from the processor and punches it in the paper tape.

0200/6022	PFC
6024	PPC
6021	PSF
5202	JMP.-1

The following logic descriptions are based on this program. The timing is shown in Figure 4-5.

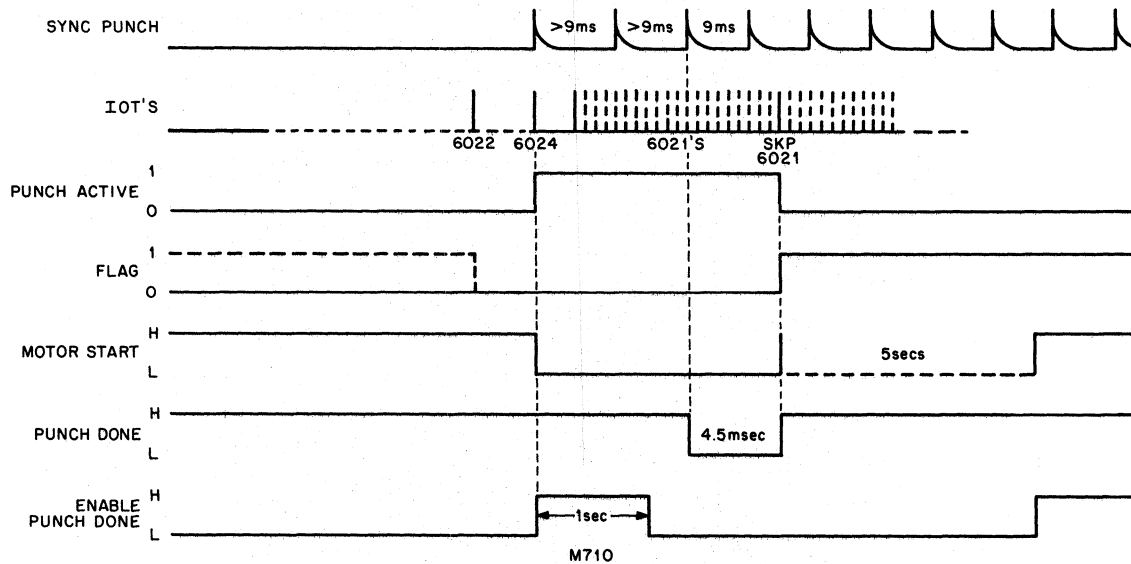

NOTE:
Timing diagram is not drawn to scale.

08-0781

Figure 4-5 Tape Punch Timing Sequence for PA68F

4.2.5 Tape Punching

Gating IOP 2 with device code 02 [BMB 03 (0) – BMB 06 (0), BMB 07 (1) and BMB 08 (0)] in M710 produces an IOT 6022 L pulse. This pulse clears:

- a. the PUNCH ACTIVE flip-flop;
- b. the PUNCH FLAG flip-flop.

The next instruction (6024) starts the punching cycle. The device code from M119 produces an AC STROBE H pulse. This pulse gates the data [BAC 4 (1) – BAC 11 (1)] from the processor through M101/M113 to the punch buffer.

Gating device code 02 with IOP 4 in M710 produces an IOT 6024 pulse. IOT 6024 H clocks the data into the punch buffer register flip-flops. A high data input sets the corresponding flip-flop, loading the associated buffer. IOT 6024 L sets the PUNCH ACTIVE flip-flop. PUNCH ACTIVE (0) H triggers a 5-second delay in M710 that produces MOTOR START L. MOTOR START L turns on the punch motor by grounding the motor control circuit in the G915 Punch Control. A simplified logic diagram is shown in Figure 4-6.

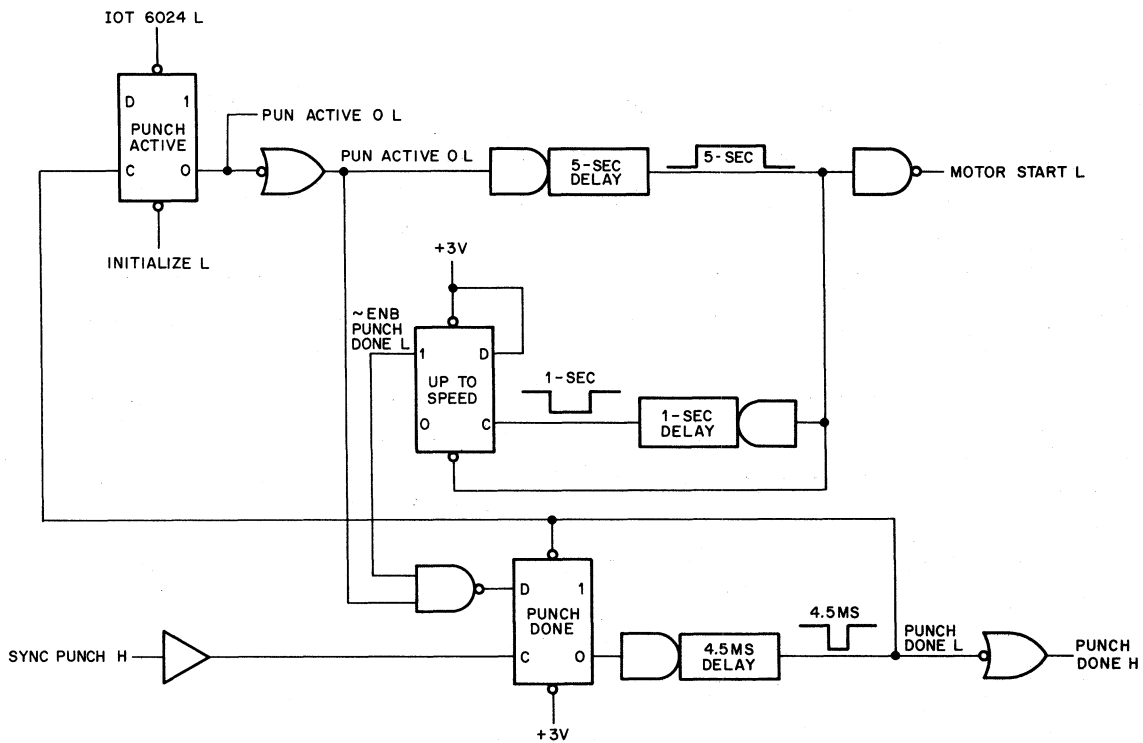

08-0780

Figure 4-6 M710 Punch Control for PA68F, Simplified Logic Diagram

A positive-going transition is produced when the 5-second delay is triggered. This transition triggers a 1-second delay in M710 that prevents punching until the motor reaches full speed. After the time elapses, \sim ENB PUNCH DONE L allows the incoming SYNC PUNCH H pulses returning from the punch pick-up coil to be gated with PUNCH ACTIVE (0) H in M710, triggering a 4.5 ms pulse shaper that produces PUNCH DONE H. The 4.5 ms PUNCH DONE H pulse gates the contents of the punch buffer to the M060 Punch Solenoid Drivers; a low output from a driver grounds the corresponding solenoid, energizing it, and punching a hole in the paper tape. When the 4.5 ms delay times out:

- a. the PUNCH ACTIVE flip-flop is cleared;
- b. the PUNCH FLAG flip-flop is set.

This condition is tested by the 6021 instruction. During the punching cycle, the processor generates a series of IOP 1 pulses. These pulses are gated with device code 02 in M710 to produce IOT 6021 H pulses. These pulses are gated with the FLAG (1) H to produce a BUS SKIP L pulse if the flag is set. The IOT 6021 H pulse that causes the BUS SKIP L pulse may occur coincident with the setting of the PUNCH FLAG flip-flop or it may occur after the PUNCH FLAG flip-flop is set.

When the BUS SKIP L pulse occurs, the processor skips the 5202 instruction. FLAG (1) H also produces an unconditional interrupt request (INTER BUS L). This signal may be used instead of the 6011 instruction to terminate the punching cycle. If another IOT 6024 L pulse is not generated within 5 seconds, the delay in M710 times out, turning the punch motor off and clearing the 1-second flip-flop.

4.3 PR68B HIGH-SPEED PAPER-TAPE READER

The PR68B is a positive logic version of the PR68A. It can be set up to read either 6-level advance feed hole or 8-level in-line feed hole tape. Reading rate is 110 cps. Operating voltages and signals are compatible with both the PR68F Single Reader/Punch Control and Interface Unit and the PA63 Multiple Reader/Punch Control Unit.

The circuit diagrams for the PR68B are listed in the Master Drawing List:

Drawing No.	Title
A-ML-PR68-B	Reader (Typesetting System)

With the exception of the voltages and signal polarities (shown on the block wiring diagram), the PR68B is identical to the PR68A. A single G908 Photoamplifier Module is used to monitor the outputs of the photodiodes and produce +3.6 Vdc when a hole is sensed and 0 Vdc when no hole is sensed.

The bias level of all nine photoamplifiers is determined by the setting of the threshold sensitivity potentiometer, R52. Drawing C-CS-G908-0-1 shows the circuit configuration of the amplifiers.

4.4 PR68D HIGH-SPEED PAPER-TAPE READER

The PR68D is a redesigned and improved reader equipped with a nontorn tape (NTTA) processing feature. This feature is implemented by adding a G930 module to the PR68DA and making some minor modifications. Operating voltages and signals are compatible with the PA63 Multiple Reader/Punch Control and Interface Unit.

The PR68D Reader can be set up to read either 6- or 8-level in-line and advanced feed hole tape. Reading rate is 110 cps. The PR68D Reader is a separate unit that can be installed at a remote location. It contains one discrete component module and one integrated circuit module.

The reader also contains: a) a light source, b) a set of phototransistors to translate the presence or absence of holes in the tape to logic levels representing 1s and 0s, and c) a tape transport mechanism to move and position the paper tape between the light source and the read head. The discrete component module, G918, is a nine-channel transistor amplifier that matches the impedance of the phototransistors to that of the buffer in the PA63 and raises the output of the phototransistors to the correct logic level. The integrated circuit module, G930, is an NTTA control that "remembers" the status of the reader and transmits this information to the control (Figure 4-7).

The circuit diagrams for the PR68D are listed in the Master Drawing List:

Drawing No. A-ML-PR68-D	Title Paper Tape Reader (PR-68D)
----------------------------	-------------------------------------

Functionally, there are three circuits: a tape transport mechanism, photoelectric tape reader, and an NTTA reader select control.

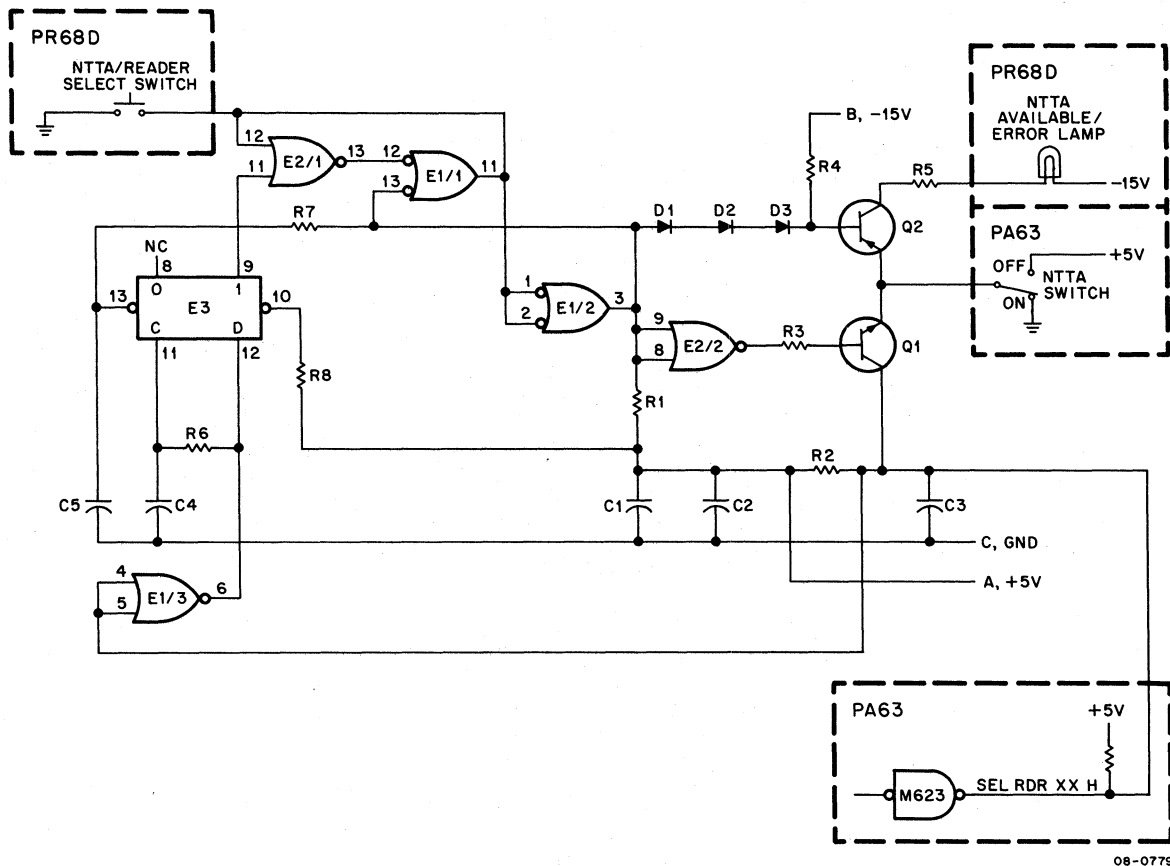

Figure 4-7 G930 Nontorn Tape Alloting Module, Simplified Logic Diagram

4.4.1 Tape Transport Mechanism

A tape-drive sprocket, rotated by a 4-pole, dc-operated synchronous motor, performs the tape-feeding function. Pins on this wheel engage feed holes in the tape to transport the tape past the read station. High-current drive pulses, generated by solenoid drivers in the PA63 produce the required torque in the motor.

Two switch-tail-connected flip-flops (A and B) in the PA63 provide the pair-sequential triggering outputs that control the solenoid drivers. Four feed cycles are required to move the tape a distance equal to one character position. Switching the activation of the solenoid pairs at 2.3 ms intervals produces a tape-feeding rate of 110 cps.

4.4.2 Photoelectric Tape Reader

The tape reading function is performed by the photoelectric tape reader. This reader consists of a light source, a photoelectric read head and associated amplifier circuits for the photocell outputs. The amplifier circuits are in the G918 module.

The read head, located below the tape, contains nine light sensitive semiconductors, physically arranged to sense perforations in the eight data tracks or channels of the tape and in the feed tape hole track. The light source is directly above the photocells. The outputs of the photocells change between the light and no-light conditions. Light passing through a hole in the tape activates the associated photocell.

The nine photoamplifier circuits in the G918 module continuously monitor the outputs of the photocells for transmission to the PA63. The bias level of all nine photoamplifiers is determined by the setting of threshold potentiometer, R37. The amplifiers generate a +3.6 Vdc output level when a hole is sensed and a 0 Vdc level when no hole is sensed. The PA63 controls the transmission of the data read from the tape and the position of the tape, which is determined by the state of the A and B flip-flops. The feed hole amplifier output is monitored to detect the out-of-tape condition.

4.4.3 NTA Reader Selection

Reader selection is controlled as described in Paragraph 4.1.3. The G930 module assumes control of reader selection when no input tape is ready for processing.

Since flip-flop E3 is cleared initially, the reader is not available for selection when the program is started. Consequently, the output of Q1 holds SEL RDR XX H at ground as the PA63 sequentially steps through each reader in the normal manner, searching for one that is available for selection. This output holds RDR SEL XX H at ground because Q1 in the G930 module and the corresponding M623 driver in the PA63 are both connected to the +5 Vdc source through the same resistor. Thus, SEL RDR XX H can not go up to that level unless Q1 is timed off.

When the switch on the reader is closed, the input to E1/2 and E2/2 is grounded, cutting off transistors Q1 and Q2. Consequently, the lamp on the reader goes off because it is not grounded. More importantly, the output of Q1 is allowed to follow SEL RDR XX H. Thus, the reader is ready for program selection, but it is not selected because \sim SEL RDR XX H from the PA63 holds the logic level at ground. The switch closure is "remembered" by E1/1 and E2/1, which hold Q1 and Q2 in cut-off until flip-flop E3 changes state.

When the PA63 produces SEL RDR XX H for the available reader, the reader is selected and input tape processing begins. However, this does not effect the flip-flop because the change from ~SEL RDR XX H to SEL RDR XX H produces a negative-going pulse at the output of E1/3. After the stop code is read at the end of the tape, the flip-flop is cleared as the PA63 deselected the reader, producing a positive-going pulse. This lights the NTTA Available/Error lamp, indicating that tape processing is complete.

4.5 PR68DA HIGH-SPEED PAPER-TAPE READER

The PR68DA High-Speed Paper-Tape Reader is a redesigned and improved reader that can be set up to read either 6-level advance feed hole tape or 8-level in-line feed hole tape. Reading rate is 110 cps. Operating voltages and signals are compatible with the PR68F Reader/Punch Control and Interface Unit. Physically, the PR68DA is identical to the PR68D; functionally, the PR68DA is identical to the PR68B. It is more reliable and easier to maintain than the PR68B because phototransistors are used instead of photodiodes.

The circuit diagrams for the PR68DA are listed in the Master Drawing List:

Drawing No.	Title
A-ML-PR68-DA	Paper Tape Reader (PR68-DA)

A single G918 Photoamplifier Module is used to monitor the outputs of the phototransistors and to produce +3.6 Vdc when a hole is sensed; 0 Vdc when no hole is sensed.

The bias level of all nine photoamplifiers is determined by the setting of threshold sensitivity potentiometer, R37. Drawing C-CS-G918-0-1 shows the circuit configuration of the amplifiers.

4.6 PP67C/D HIGH-SPEED PAPER-TAPE PUNCH

The PP67C/D Punch is a modified BPRE Punch, Model 11 or Model 18. Four models are available, depending on the number of channels required and the power available.

Type	Tape Level	Voltage and Line Frequency
PP67C	6-advanced feed hole	115V, 60 Hz
PP67CA	6-advanced feed hole	115V, 50 Hz
PP67D	8- in-line	115V, 60 Hz
PP67DA	8- in-line	115V, 50 Hz

Punching rate is 110 characters per second. The PP67C/D Punch is a separate unit that can be installed in a remote location; it contains one discrete component module. The circuit diagrams for the PP67C/D are listed in the Master Drawing List:

Drawing No.	Title
A-ML-PP67-C	Paper Tape Punch PP67-C

The punch also contains: a) a punch drive motor, b) a mechanism to advance the tape and position it under a perforating mechanism, c) a perforating mechanism that translates logic levels representing 1s and 0s to the presence or absence of holes in the tape. A roll of tape is loaded in the punch. As the tape is perforated by the punch, it is collected for processing by a linecasting or a phototypesetting machine. The discrete component module, G915, is a punch control that monitors the status of the punch and transmits this information to the reader punch control.

The circuits for the PP67C/D Punch are shown in drawings D-CS-PP67C-1 and D-CS-PP67D-1. Functionally, there are two separate circuits, a motor control and a solenoid control that are both located on the G915 Punch Control Module (drawing B-CS-G915-0-1).

4.6.1 Motor Control

Figure 4-8 is a simplified functional diagram of the motor control circuit. The punch motor is controlled by MOTOR START L from the control. When the control switch on the punch is in the AVAILABLE position, MOTOR START L grounds Q5 in Punch Control, G915. This, in turn, energizes relay K1. The closed contacts of K1 allow the 110 Vac input to trigger SCR D2 in the punch, supplying ac current to the motor.

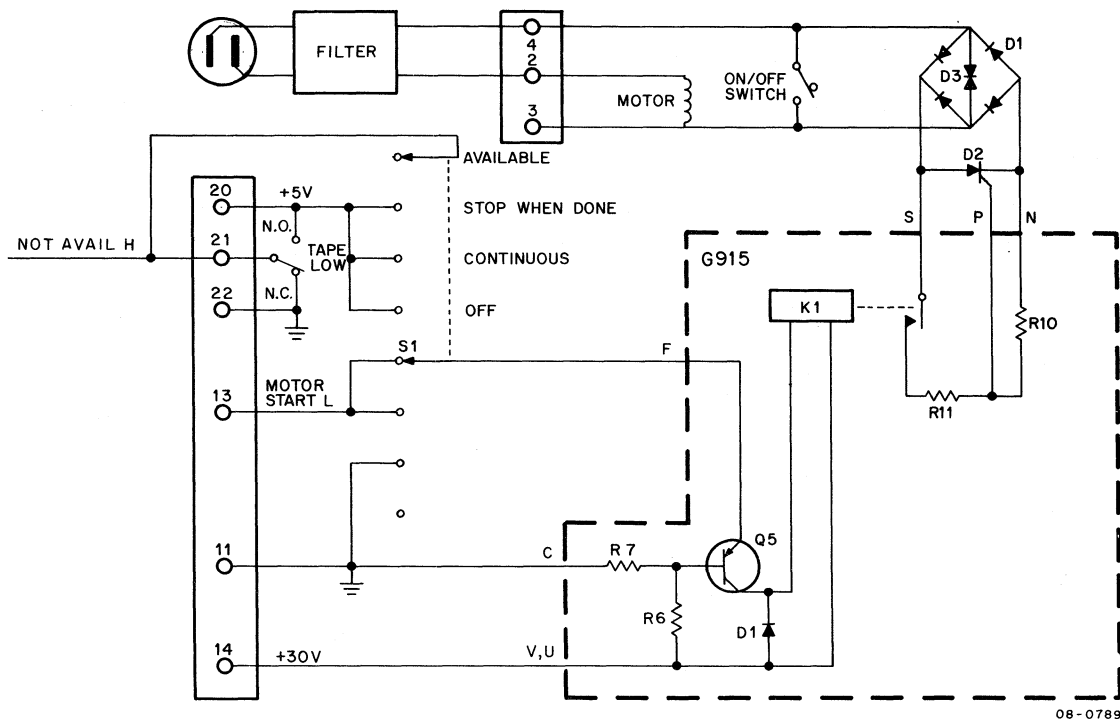
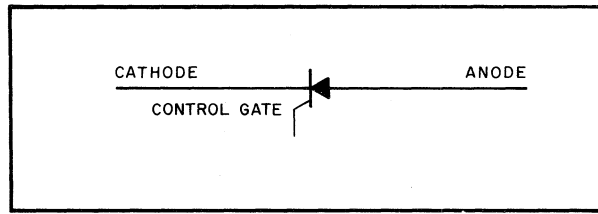

Figure 4-8 Punch Motor Control, Simplified Functional Diagram

During the first half cycle of the ac input, the voltage on the control gate of D1 at the junction of R10 and R11 turns on the SCR. Therefore, current flows through the motor winding, driving the motor. At the end of the first half cycle the anode voltage is reduced to zero, hence the SCR turns off. During the second half of the cycle, however, the voltage at the control gate turns on the SCR again.

NOTE

In the OFF condition, an SCR has a high resistance (approximately 100 k Ω) in both directions (anode to cathode and cathode to anode). The cathode control gate is the equivalent of a small diode. If a low positive voltage is applied to the gate when the anode is positive and the cathode is negative, the resistance is greatly reduced and current will flow through the SCR. After the SCR is triggered, it can only be turned off by removing the anode voltage.



11-1164

Silicon Controlled Rectifier

Thus, the full wave bridge rectifier, D1, supplies unfiltered, unregulated dc for the SCR. The thyristor, D3, regulates the 110 Vac input. The SCR switches the 110 Vac input to the motor. The punch motor can also be turned on by closing the ON/OFF switch. However, this switch should only be used during maintenance because it does not place the punch under program control.

While the punch has sufficient tape, \sim NOT AVAIL H is applied to the reader/punch control because the wiper of S1 is grounded through the contacts of the tape low indicator arm. When the tape goes below the limit (approximately 3/8-inch of paper left on the core), the wiper of S1 is connected to +5 Vdc through the contacts of the tape low indicator arm, applying NOT AVAIL H to the reader/punch control.

NOT AVAIL H is also produced when the control switch is set to STOP WHEN DONE, CONTINUOUS, or OFF. The punch motor runs continuously when the control switch is in the CONTINUOUS position because MOTOR START L is grounded.

4.6.2 Solenoid Control

The punch solenoids are energized by MOTOR START L and P HOLE 00 L through P HOLE 07 L from the reader/punch control. MOTOR START L grounds Q1 in G915. This triggers SCR Q4, which switches +30 Vdc to the solenoids. A discrete solenoid is energized by P HOLE XX L, which grounds the corresponding solenoid.

SYNC PUNCH pulses generated by a reluctance pickup, synchronize the solenoids with the reader/punch control. The pickup is driven by the punch motor.

Figure 4-9 is a simplified functional diagram of the punch solenoid circuit.

CAUTION

Do not turn on power when an M710 Punch Control Module is removed from the reader/punch control. Damage to the punch solenoid circuit could result.

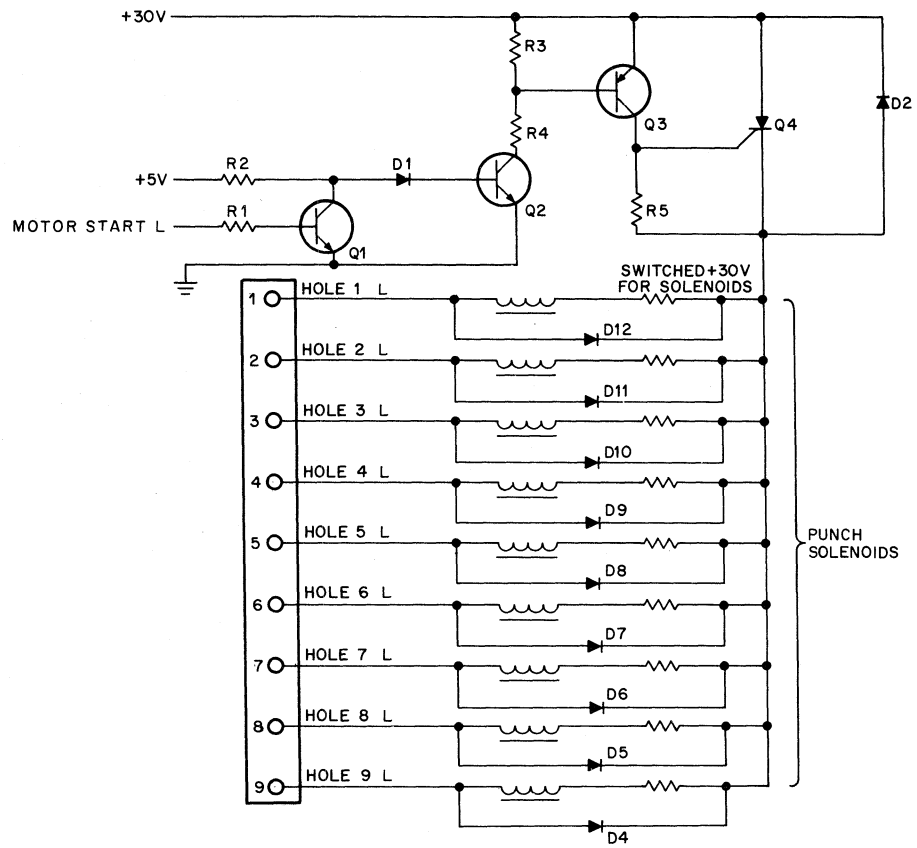

08-0790

Figure 4-9 Punch Solenoid Control, Simplified Functional Diagram



CHAPTER 5

ADJUSTMENTS

This chapter covers the adjustment procedures for the M401 Clock Module and the M710 Punch Control Module in the PA63 and PA68F Controls, the PR68B, PR68D/DA Readers and the PP67C/D Punches. A complete system, including a processor and a Teletype, are required to run the programs and to make the adjustments using these procedures. The maintenance test equipment and the diagnostic test programs listed in Paragraph 6.1 and the engineering drawings in Volume 2 of this manual are also required to perform these procedures properly.

The procedures should be followed as closely as possible in the order in which they are presented. Processor power must be turned on and off, as necessary, throughout the adjustments.

5.1 M401 READER CLOCK

The purpose of the reader clock adjustment is to set the period of the clock pulses that determine the operating speed (running rate) of the reader. An oscilloscope is required to make this adjustment. The adjustment procedure is:

1. Connect the oscilloscope to A15D2 on the PA63 or B08D2 on the PA68F.
2. Adjust potentiometer R8 (Figure 5-1) to obtain the waveform shown in Figure 5-2.

5.2 M710 PUNCH CONTROL

The purpose of the punch control adjustment is to set the width of the PUNCH DONE pulse. An oscilloscope is required to make this adjustment. The adjustment procedure is:

1. Turn off computer power and place the M710 on an extender board.
2. Load the following program into location 7000:

7000/	7040	CMA
	6026	PLS
	6021	PSF
	5202	JMP.-1
	5200	JMP.-4

3. Set SR to starting address (7000), depress LOAD ADD and START.
4. Connect the oscilloscope to AB30 BH2 on PA63 or AB07 BH2 on PA68F and adjust potentiometer R4 (Figure 5-3) to obtain the waveform shown in Figure 5-4.

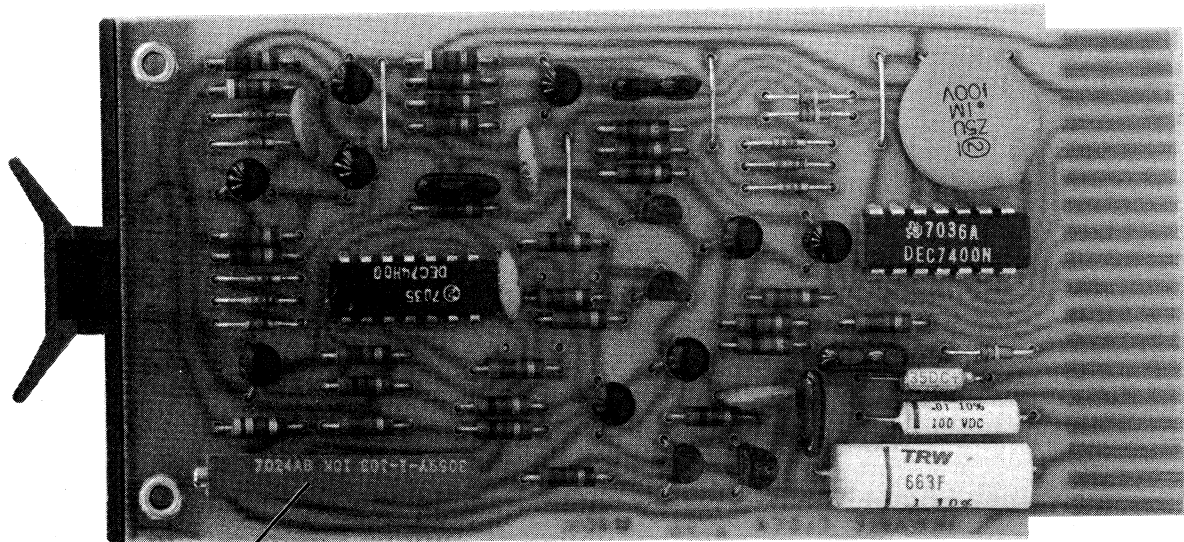

R8

Figure 5-1 M401 Reader Clock Adjustment Location

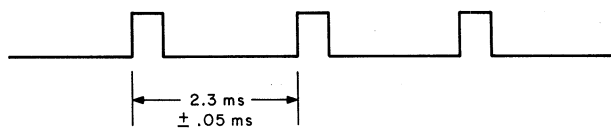

11-1166

Figure 5-2 Clock Pulse Waveform

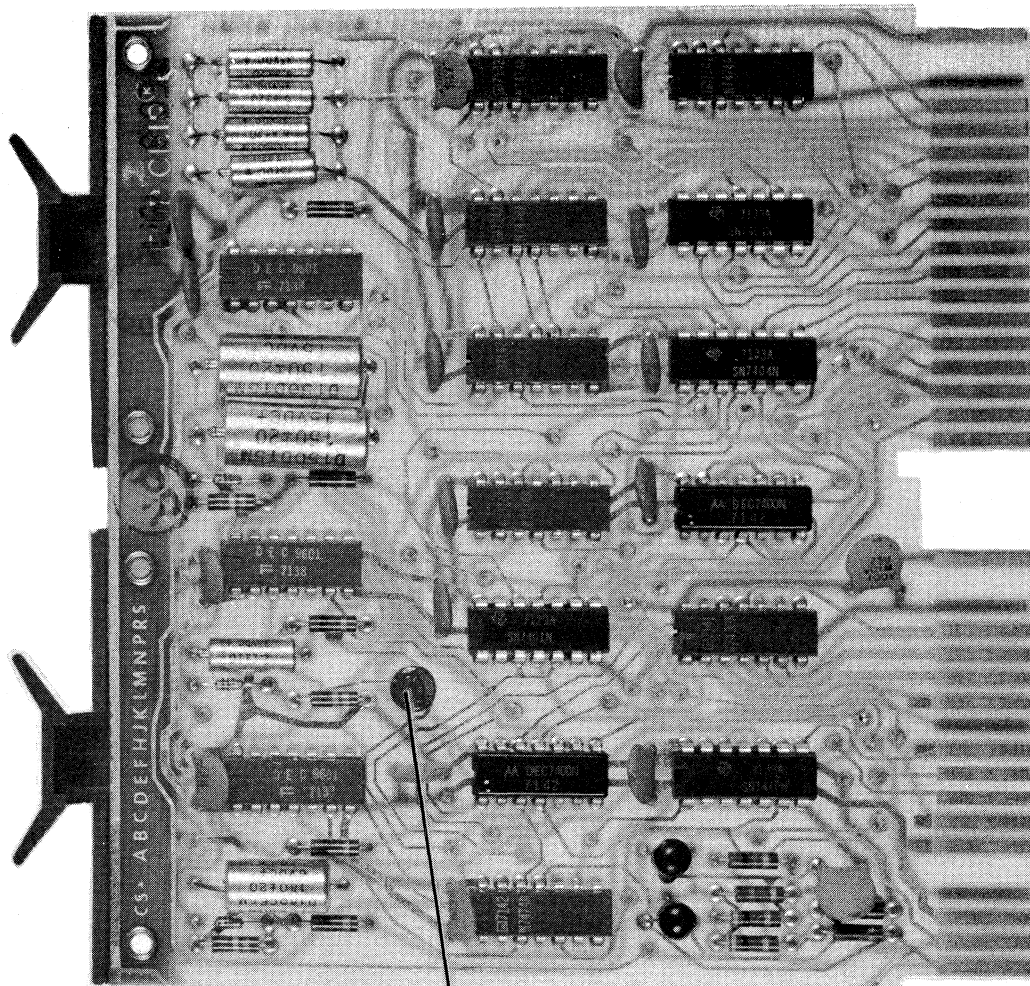

R4

Figure 5-3 M710 Punch Control Adjustment Location

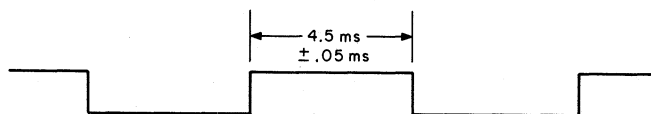

11-1167

Figure 5-4 Punch Done Pulse Waveform

5.3 PR68B HIGH-SPEED PAPER-TAPE READER

The mechanical, electrical, electronic, and optical mechanisms of the PR68B Reader can be adjusted if they are causing data errors. A multimeter and an oscilloscope are required to make the adjustments. Static adjustment of the mechanical, electrical, and optical mechanisms must be made before the G908 Photoamplifier can be adjusted. The G908 adjustment can be made without an oscilloscope if necessary. Adjustable mechanisms are shown in Figure 5-5

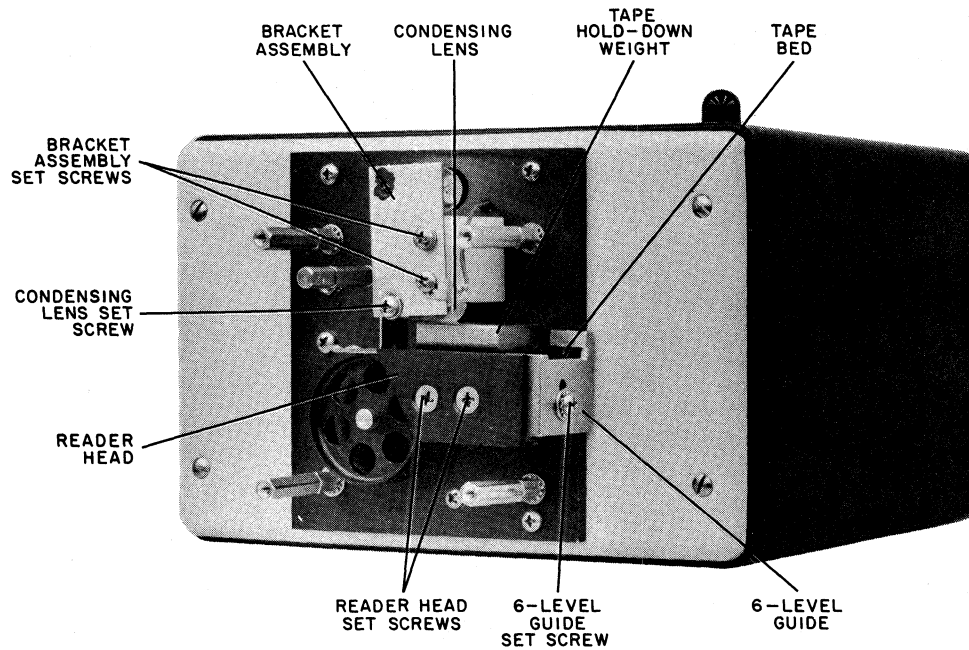

RIGHT FRONT VIEW

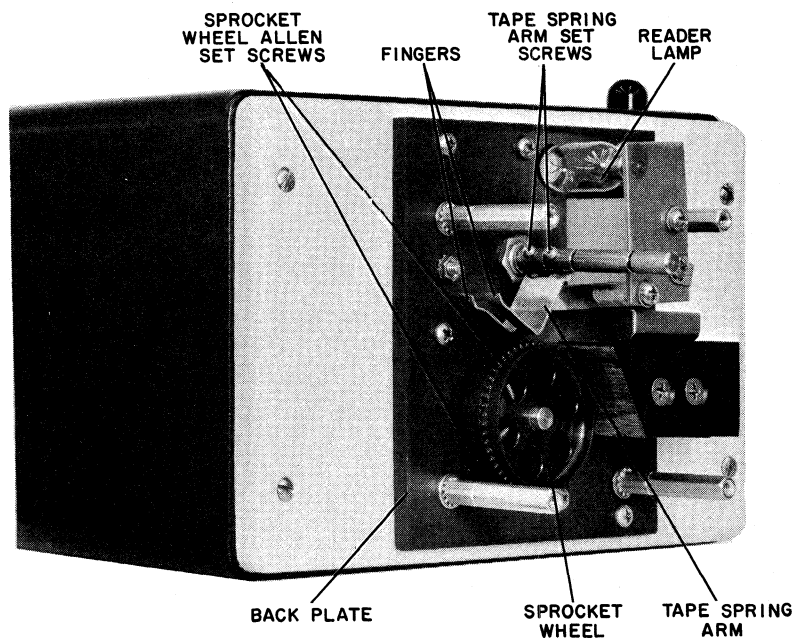

LEFT FRONT VIEW

Figure 5-5 PR68B Reader Adjustment Location

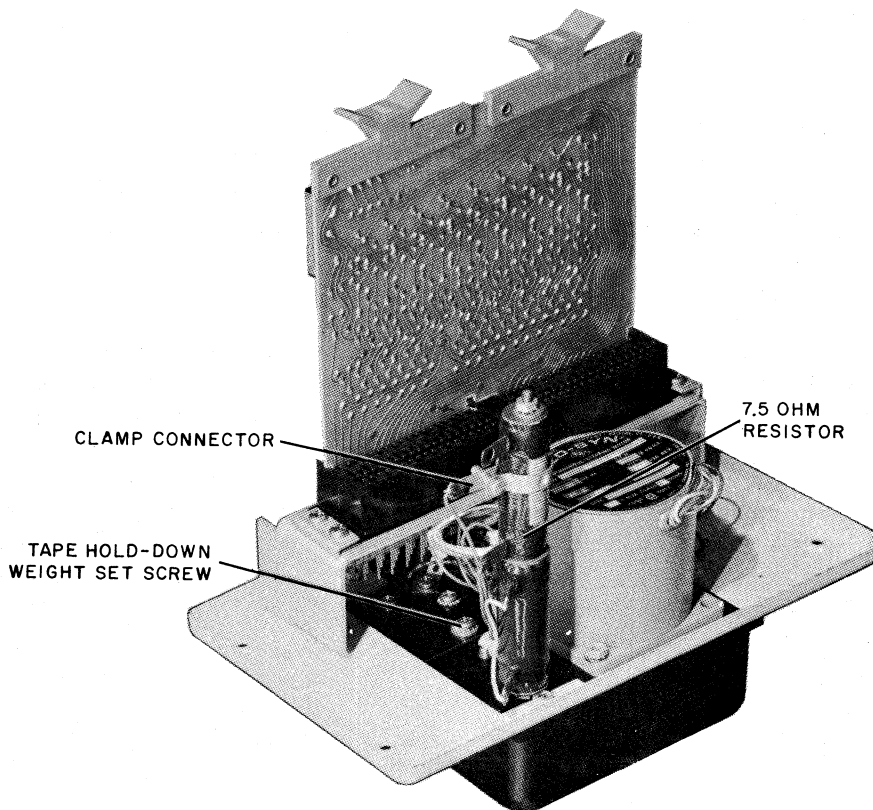

OBLIQUE INTERIOR VIEW

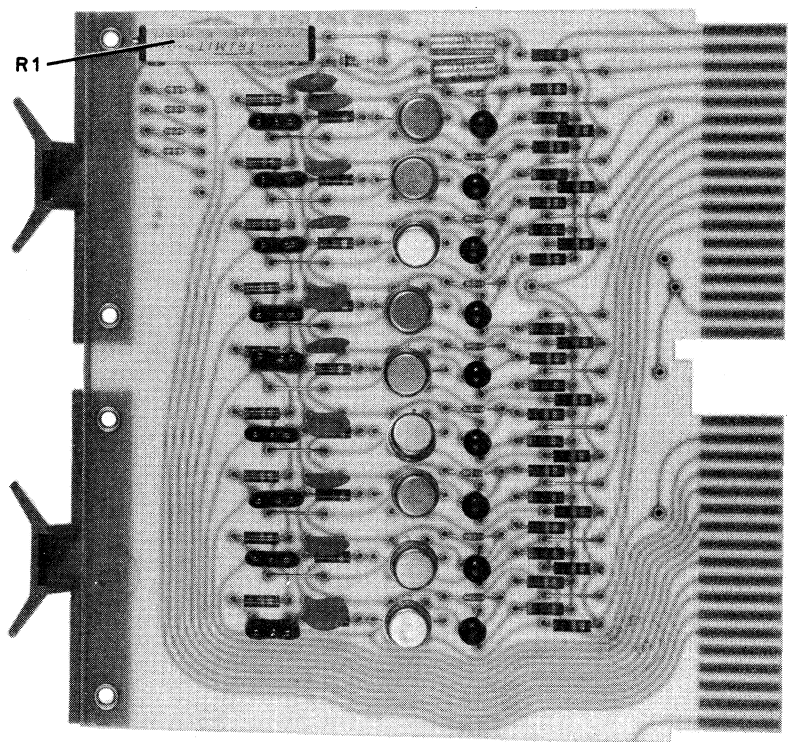

G908 PHOTOAMPLIFIER MODULE

Figure 5-5 PR68B Reader Adjustment Location (Cont)

5.3.1 Static Adjustment

1. Measure the voltage across the reader lamp. It should be 10 Vac. If it is not, loosen the clamp connector on the 7.5Ω resistor in the reader and move the clamp until 10 Vac is obtained (Figure 5-5). Tighten the clamp, then recheck voltage. If cables are over 75 ft, the -15V and ground lines must have dual wires in the cable.
2. Release the screw holding the 6-level guide and if the reader is to be used for 8 level, drop the guide to its lowest position and tighten the screw. If the reader is to be used for 6 level, move the guide up until the guide surface is flush with the surface of the reader head. Tighten the screw.
3. Take a short piece of tape, 6 or 8 level appropriate to reader use, and place it in the reader. Adjust the reader head with the two screws shown, so that the tape lies flat across the sprocket wheel and the reader head surface (Figure 5-6). Tighten the screws.
4. Place three thicknesses of tape between the tape bed and pressure pad and tighten the screw that connects it to the reader plate. The pad should now be secured.

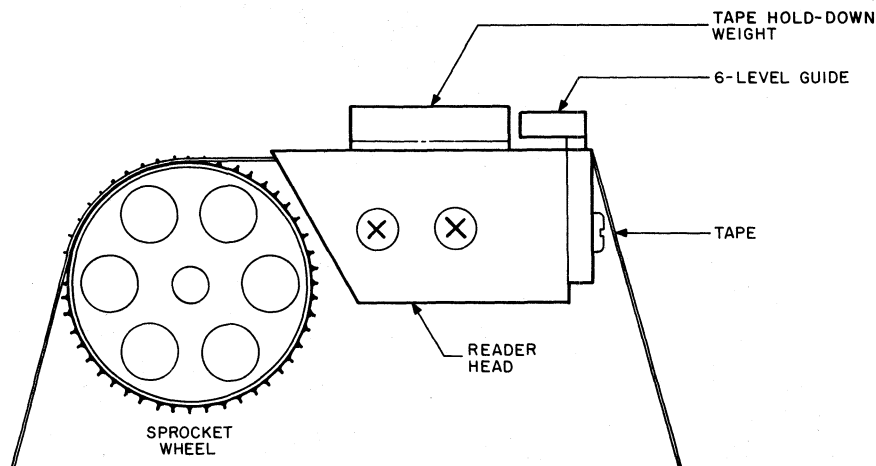

Figure 5-6 6-Level Guide and Reader Head Adjustment

5. Rotate the reader lamp so that the filament produces an even beam of light and casts no shadow from the bulb's seam, over the photocell apertures (Figure 5-7). (Note: inspect the bulb for filament sag, if present replace the bulb.) Adjust the condensing lens so that the flat portion is parallel with the reader head. Loosen the two set screws on the bracket assembly and move it forward or backward to make the light beam cut across the right-hand edge of the apertures.
6. Take a short piece of tape with a rubout code perforated about half way along the tape and place it in the reader. Loosen the two Allen set screws in the sprocket wheel and, while holding the tape taut across the cell block and wheel, move the sprocket wheel laterally so that the holes in the tape are centered over the photocell apertures (Figure 5-8). Be sure that the tape is not curled up against the reader plate. Partially tighten one of the screws.

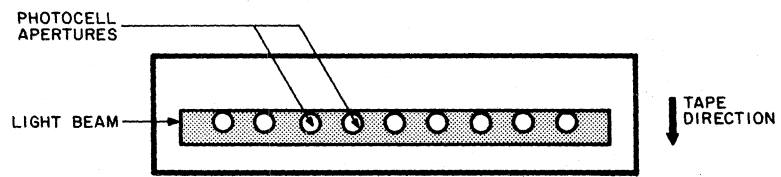
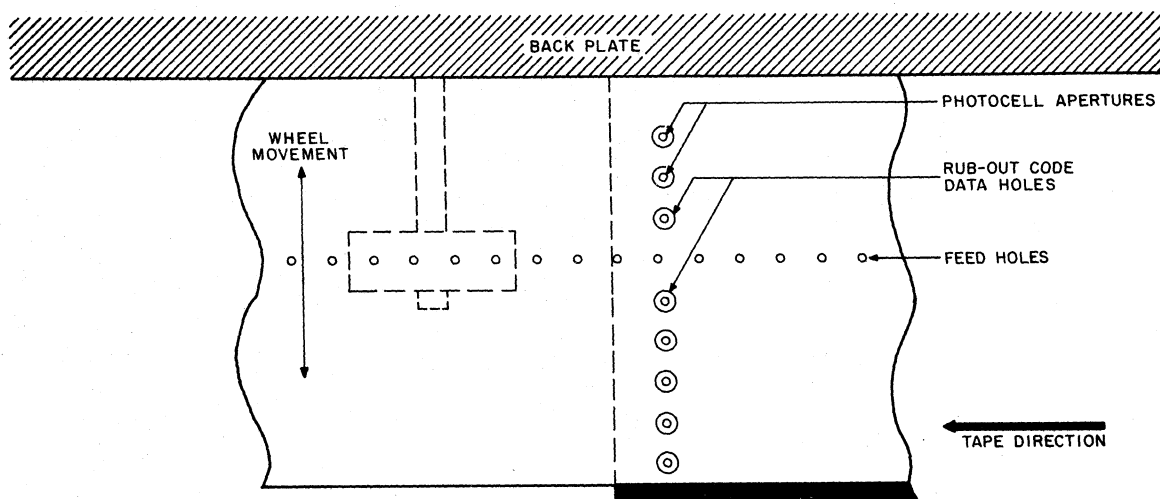

Figure 5-7 Reader Lamp and Condensing Lens Adjustment



08-0763

Figure 5-8 Lateral Adjustment of Sprocket Wheel

7. Select the required reader via the PA63 control by loading the following program:

```

0 / 7604 LAS
    6312 RSC
    7402 HLT

```

Load ADD 0, set the reader number in SR bits 8-11, then press START.

8. Release the screw in the sprocket wheel, and keeping the lateral position fixed, rotate the wheel axially until the leading edge of the tape holes just touch the right-hand edge of the light beam (Figure 5-9). Tighten the Allen set screws in the wheel.
9. Put the tape spring arm down and check that the straight part of the fingers are horizontal and just touching the wheel (Figure 5-10). Also check that the fingers are centered over the sprockets on the wheel, sighting from the top of the reader. The adjustment can be made by carefully bending the tape spring arm and the fingers, using a pair of long nose pliers.

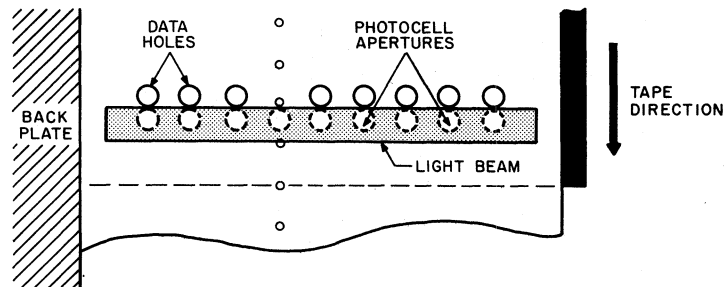

08-0764

Figure 5-9 Axial Adjustment of Sprocket Wheel

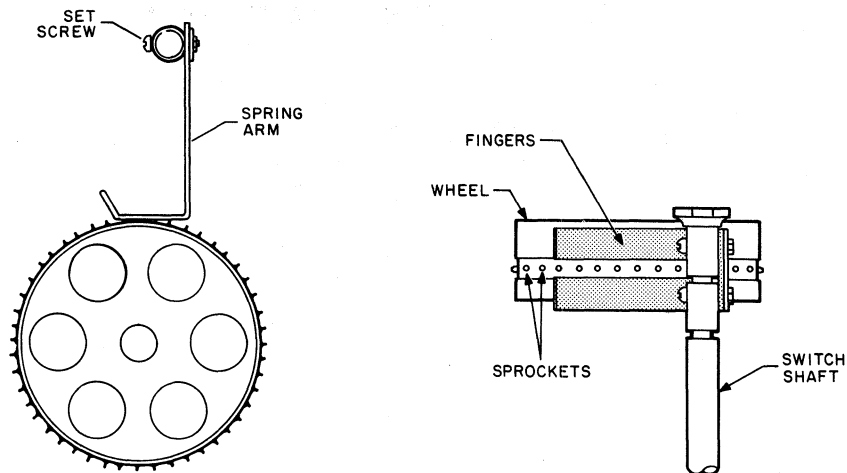

08-0765

Figure 5-10 Spring Arm Adjustment for PR68B

5.3.2 Dynamic Adjustment

After all preliminary static adjustments have been made, the reader should be margined. There are two methods of doing this, depending on the available test equipment.

Method 1

1. Using a short program or Typesetting Configuration Test Program 10, read a 1s and 0s test tape loop. Observe the AC for data and adjust the potentiometer on the G908 through its entire range from the point where bits are picked up to the point where bits are dropped, counting the number of full turns required.
2. Set the potentiometer back 40% from the point where bits are picked up; e.g., if ten turns are counted, set the potentiometer back four turns from the pickup point. Ordinarily the feed hole will be picked up first when checking bits 1, 2, 3, and 4, causing the program to hang up on the flag. This is the end of the range in that direction.

NOTE

The minimum range that should be obtained from the potentiometer is six turns.

Method 2

1. Using an oscilloscope, read a 1s and 0s test tape loop at full speed and monitor B27E2 on the PA63 data hole; or B11E2 on the PA68F and C8U1 on the PA63; or B13U1 on the PA68F. Observe the relationship between the data and the "strobe" output of the B flip-flop.
2. Adjust potentiometer R1 and, if necessary, the sprocket wheel to obtain the timing shown in Figure 5-11.
3. Repeat steps 1 and 2, monitoring B28P1 on the PA63 (data hole 3) or B10P1 on the PA68F. To check for skew, compare data hole 0 and data hole 5 (B28J1 on the PA63 or B10J1 on the PA68F).
4. After the margins have been set up correctly, read a short piece of tape to ensure that the PA63 or the PA68F recognizes the "out-of-tape" condition as the tape runs out. A slight readjustment of the G908 may be necessary, but the change should not be too far from the 40/60 setting, if Method 1 was used. Also, check that the "out-of-tape" condition is recognized when the tape spring arm is raised.

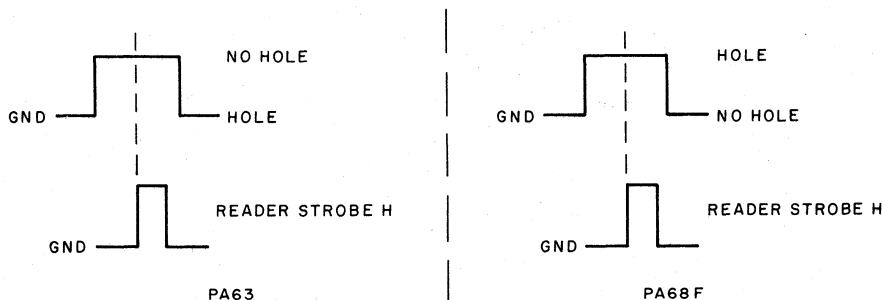

08-0778

Figure 5-11 Relationship of PR68B Reader Data Pulse and Strobe Pulse for PA63 and PA68F

5.4 PR68D/DA HIGH-SPEED PAPER-TAPE READER

The mechanical, electrical, electronic, and optical mechanisms of the PR68D/DA Reader can be adjusted if they are causing data errors. A multimeter and an oscilloscope are required to make the adjustments. The adjustable mechanisms are shown in Figure 5-12. The tape guide, tape level slide, lamp voltage and sprocket wheel, and lens alignment must be made before the G918 Amplifier can be adjusted. The G918 adjustment can be made without an oscilloscope, if necessary.

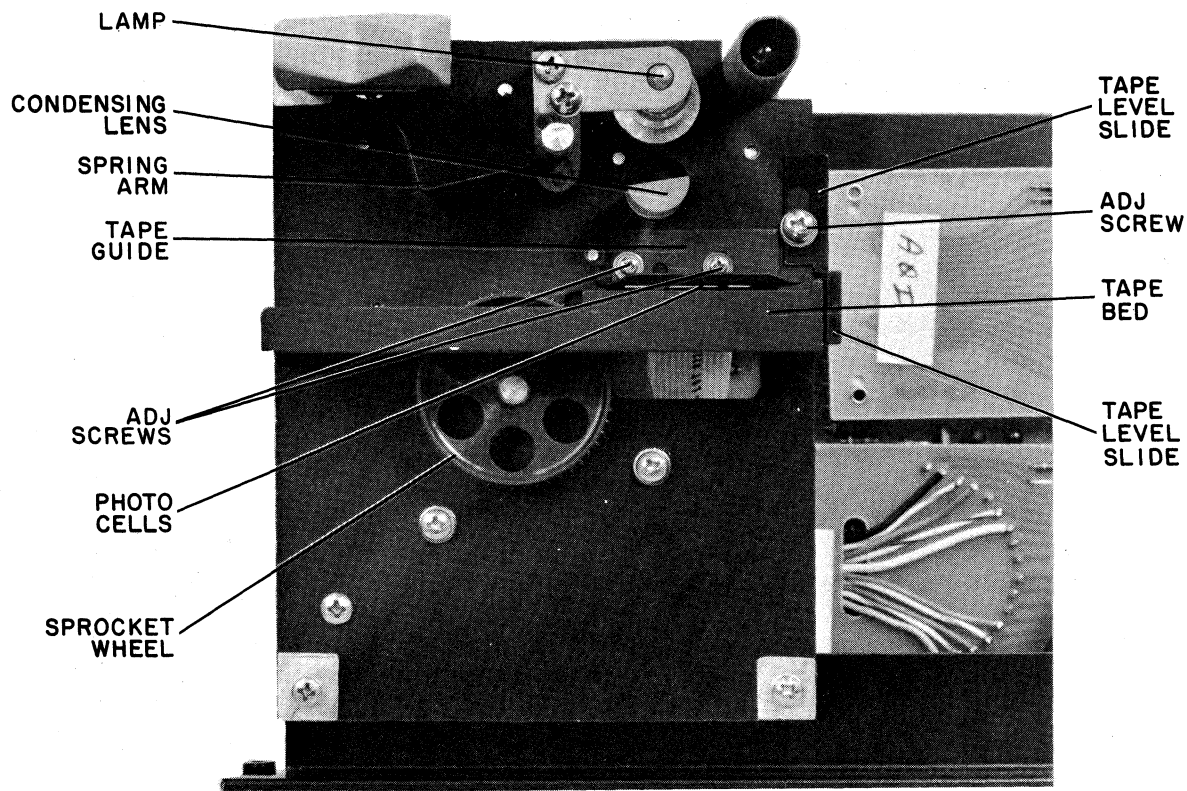

FRONT VIEW

Figure 5-12 PR68D/DA Reader Adjustment Location

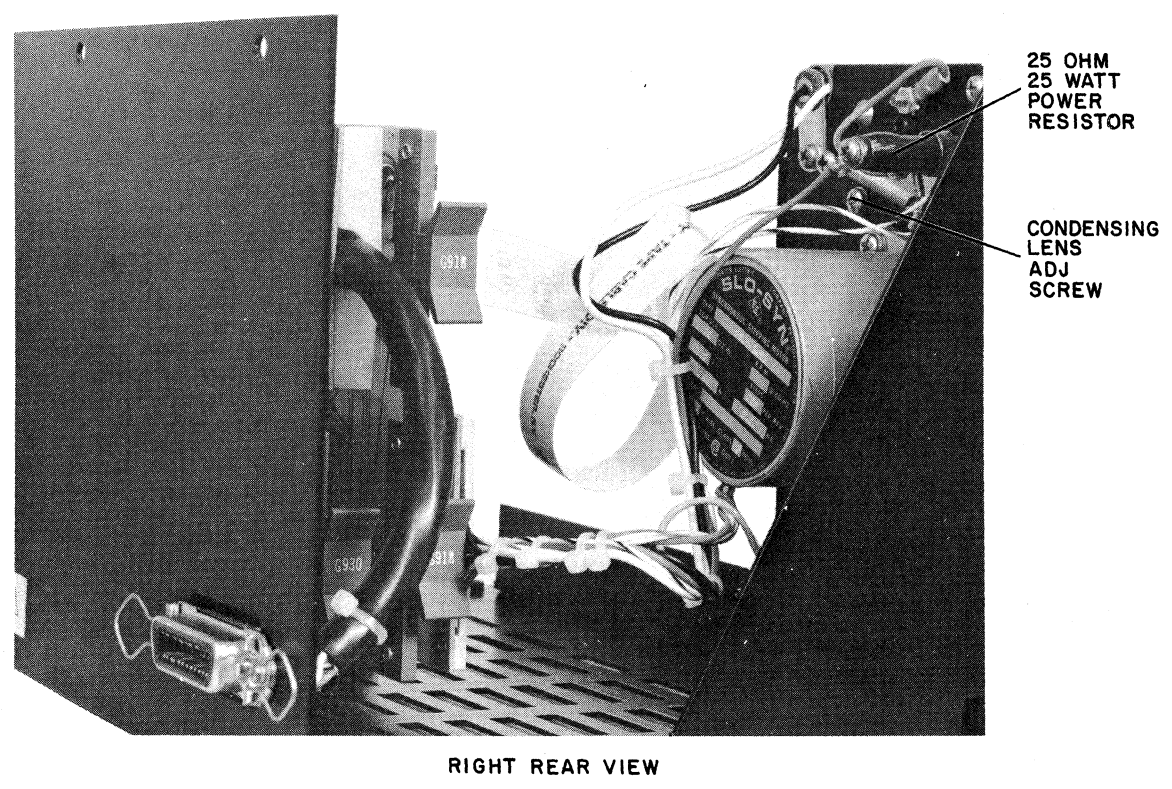
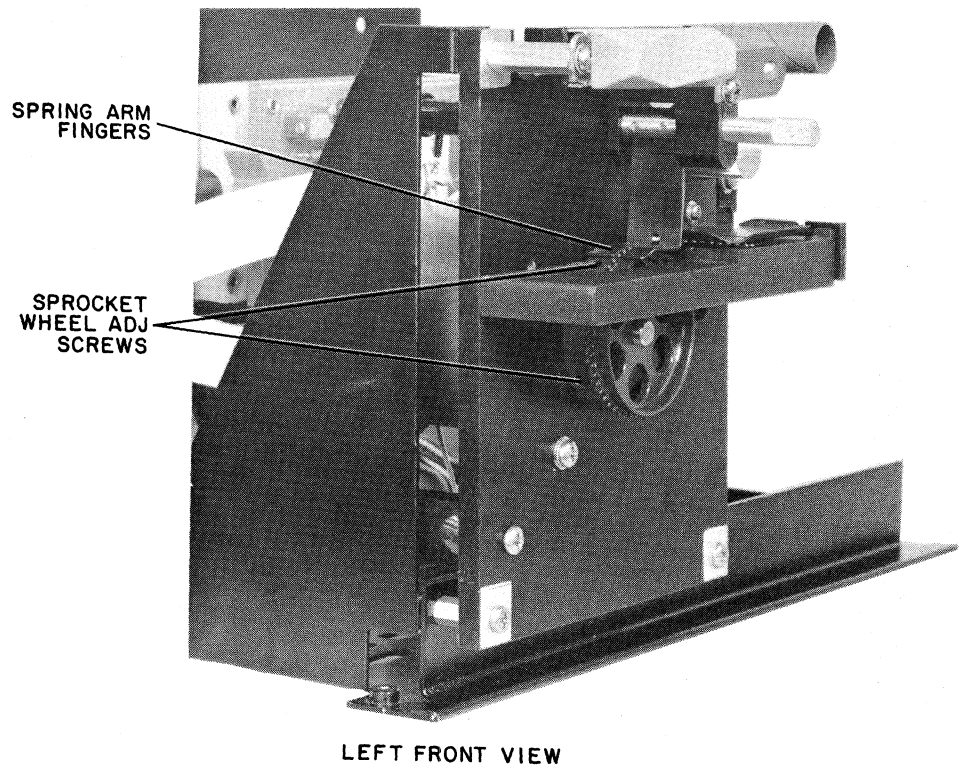
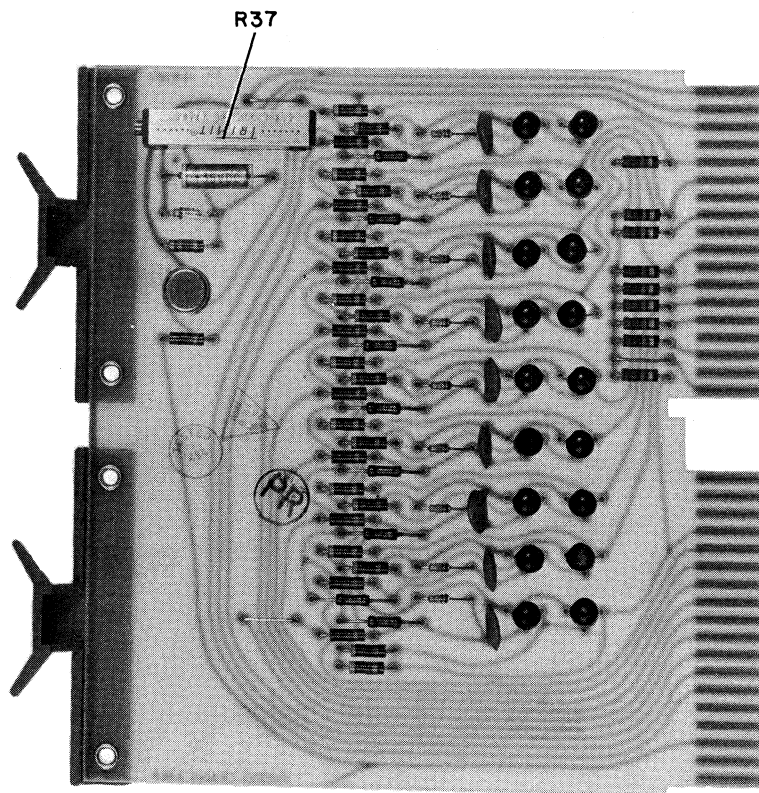

Figure 5-12 PR68D/DA Reader Adjustment Location (Cont)



G918 PHOTO AMPLIFIER MODULE

Figure 5-12 PR68D/DA Reader Adjustment Location (Cont)

5.4.1 Tape Guide

1. Loosen two screws and adjust the tape guide so that the opening is centered over the photocells and does not block the light path.
2. Place three thickness of paper tape in the reader and adjust the gap between the bracket and the tape. Tighten the screws.

5.4.2 Tape Level Slide

1. Release the screw holding the tape level slide.
2. Adjust the slide for the tape being used. For 8-level tape, drop the slide to the lowest position and tighten the screw. For 6-level tape, move the slide up until its surface is flush with the surface of the tape bed and tighten the screw.

5.4.3 Lamp Selection and Voltage

1. Rotate the lamp so that the filament produces an even beam of light and does not cast a shadow over the apertures. There are two seams in the lamp that must be kept out of the light path.

NOTE

When installing a new lamp, select one that has a reasonably straight and uniform filament. Always position the lamp with the engraved end toward the frame.

2. Inspect the lamp for filament sag and replace it if sag is present.
3. Measure the voltage across the reader lamp. If it is not -5.8 Vdc, loosen the clamp on the 25 Ω , 12W power resistor and adjust it for the correct voltage. This adjustment compensates for variations in the intensity of the light produced by the lamp.

5.4.4 Sprocket Wheel and Condensing Lens

1. Adjust the condensing lens so that the flat portion is parallel to the tape bed.
2. Project the forward edge of the light band along the leading edge of the data holes by rotating the lamp or tilting the lens, if necessary. The lens should project a narrow beam that is wide enough to cover the data holes completely (Figure 5-13).
3. Take a short piece of 8-level tape with a rubout code perforated about half way along the tape and place it in the reader.
4. Release the two Allen set screws in the sprocket wheel and, while holding the tape taut across the tape bed and wheel, move the sprocket wheel laterally so that the holes in the tape are centered over aperture (Figure 5-13). Be sure that the tape is not curled up against the back plate. Partially tighten one of the screws.

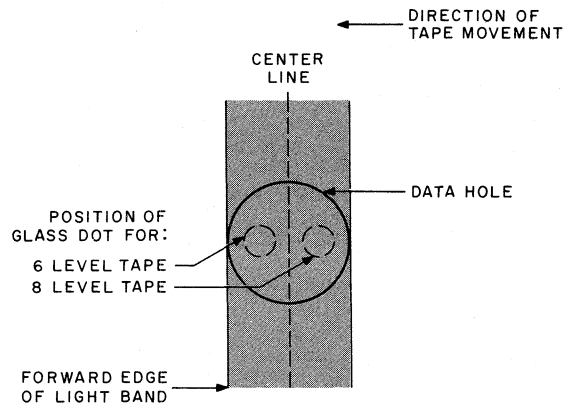

11-1168

Figure 5-13 Relationship of Data Hole and Photocell for PR68D/DA

5. Release the screw in the wheel and, while keeping the lateral position fixed, rotate the wheel axially until the leading edge of the feed hole is just touching the forward edge of the light beam. Tighten the Allen screws in the wheel.

NOTE

The lateral and rotational position of the sprocket wheel provides clearance for the paper tape and positions the data holes over the correct photocell apertures. The correct mechanical relationship of the data hole and the photocells is shown in Figure 5-13. Notice that the relationship between the holes and the glass dot is not the same for 6-level tape as it is for 8-level tape. Refer to Paragraph 5.3.5.

6. Put the spring arm down and check that the straight part of the fingers are horizontal and just touching the wheel (Figure 5-14). Also check that the fingers are centered over the sprockets on the wheel, sighting from the top of the reader. Adjustment can be made by carefully bending the spring arm and the fingers and, if necessary, using a pair of long nose pliers.
7. Substitute a 6-level tape for the 8-level tape in the reader. The center of the data holes should be just to the right of the glass dot on the photocell (Figure 5-13).

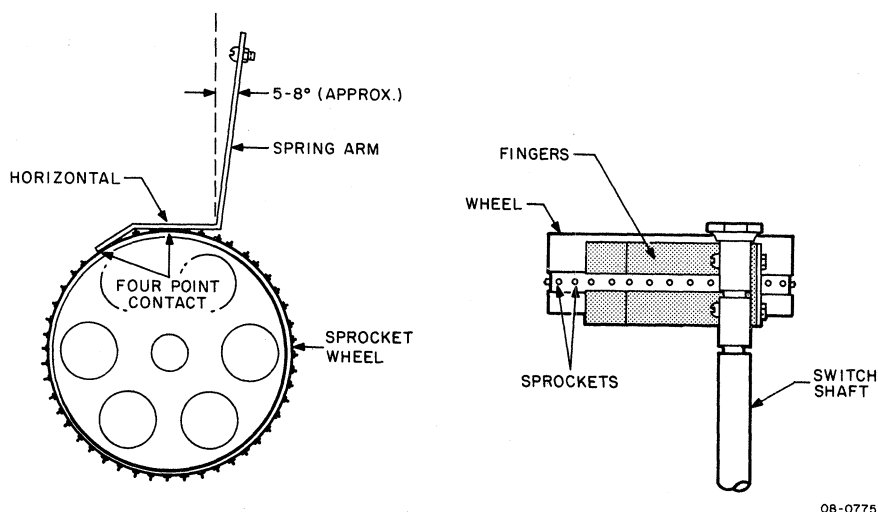

Figure 5-14 Spring Arm Adjustment for PR68D/DA

5.4.5 G918 Amplifier Adjustment

After all preliminary alignment and control settings have been made, the reader can be margined. The purpose of the margin adjustment is to set the threshold bias level of the amplifiers at a point midway between the upper and lower margins. There are two methods of doing this, depending on the available test equipment.

Method 1 does not require any test equipment. The range of threshold potentiometer, R37, is determined by a trial adjustment, using a diagnostic test program to read a test tape and the Teletype to identify the points at which the reader causes an error by picking up and dropping bits. The potentiometer is set at a point midway between these two points.

Method 2 requires an oscilloscope. This method determines the exact location of the midway point by measurement; it uses a test program to read the test tape and an oscilloscope to monitor the relationship between the data pulse from reader hole 0 and the strobe. The potentiometer is set at this point.

Method 1

1. Load MAINDEC-08-DZHC-PB into memory, using the Teletype.
2. Place a 1s and 0s test tape loop in the reader, select program 10 and depress the NTTA/Reader Select switch.
3. Adjust potentiometer R37 on the G918 through its entire range, counting the number of full turns required between the two points at which the Teletype responds.

NOTE

The minimum range of the potentiometer should be 10 turns.
If less than 10 turns are required, realign the sprocket wheel
as directed in Paragraph 5.4.4.

4. Set the potentiometer to a point midway between these two points. For example, if 10 turns are counted, set the potentiometer back 5 turns from the point at which the last response Teletype was obtained.

Method 2

1. Load the following program into location 7000:

7000/	7300	CLA CLL
	6016	RRB RFC
	6011	RSF
	5202	ISZ TEMP
	5200	JMP -.4

2. Place a 1s and 0s test tape loop in the reader.
3. Set SR to starting address (7000), depress LOAD ADD and START.
4. Depress the NTTA/Reader Select switch.
5. Connect the oscilloscope as follows:

Channel	Connection	Signal
1	A04T2	+30V strobe
2	A02V2	reader hole composite

NOTE

If there is no data signal on channel 2, adjust potentiometer
R37 on G918 until a data pulse appears.

The data pulse should coincide with the strobe as shown in Figure 5-15. The positive portion of the data pulse should be centered on leading edge of the negative portion of the strobe. If the waveform relationship is incorrect, align the sprocket wheel as directed in Paragraph 5.3.4.

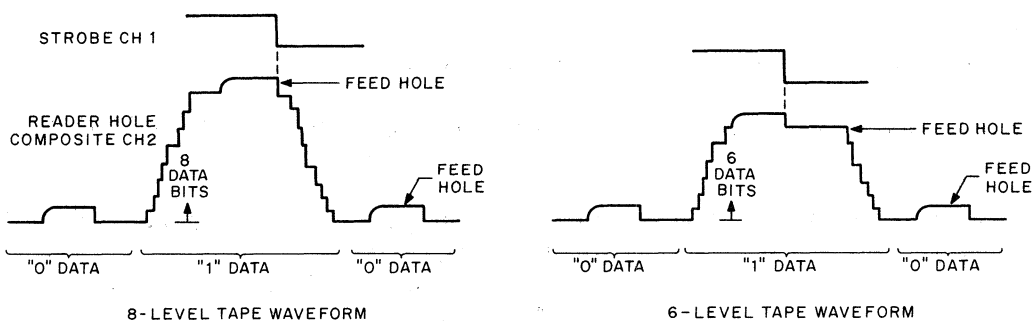

08-0791

Figure 5-15 Relationship of PR68D/DA Reader Data and Strobe Pulse

5.5 PP67C/D HIGH-SPEED PAPER-TAPE PUNCH

All mechanical adjustments for the PP67C/D Punch are provided in Teletype Corporation Bulletin 215B. After these adjustments have been made, operational adjustments can be made. Operational adjustment procedures are provided in the following paragraphs for the punch mechanism and the low tape indicator arm.

5.5.1 Punch Mechanism Adjustment

The punch mechanism can be adjusted if it is causing perforation of incorrect data. An oscilloscope is required to make the adjustment. The adjustment procedure is:

1. Load the following program into location 0200:

200/	7604	OSR
	6314	PSC
	7200	CLA
	6026	PLS
	6021	PSF
	5204	JMP .-1
	2220	ISZ TEMP
	5206	JMP .-1
	7040	CMA
	5203	JMP .-6

NOTE

The program must contain a stall to check the feed hole solenoid so that the solenoid is de-energized between character punching. The preceding program can be loaded and used when checking all data solenoids and the feed hole.

2. Set SR to starting address (0.200) and depress LOAD ADD. Set SR bits 8 through 11 to punch N⁰ and depress START.
3. As the punch perforates alternate 0s and 1s, check each solenoid by connecting the scope probe to the tab that comes from the solenoid driver via J1-L through J1-9 (usually the solid color wire). Use channel 2 of the scope, with the INVERTER switch pulled out.

- The "glitch" in the sawtooth waveform (Figure 5-16) should be positioned at the trailing edge as shown. If it is not, loosen the two screws holding the punch solenoid clamp and adjust the solenoid.

NOTE

Move the solenoid squarely in the vertical direction when making this adjustment. Tilting the solenoid may cause the armature to slip out of the blocking pawl.

- Loosen the screw holding the range finder and move the slide until punching begins to deteriorate. Note the position on the scale.
- Move the slide in the opposite direction until punching begins to deteriorate again. Note the position on the scale.
- Set the range finder midway between the two positions and tighten the screws.

NOTE

On a new or rebuilt punch the normal setting is 30°.

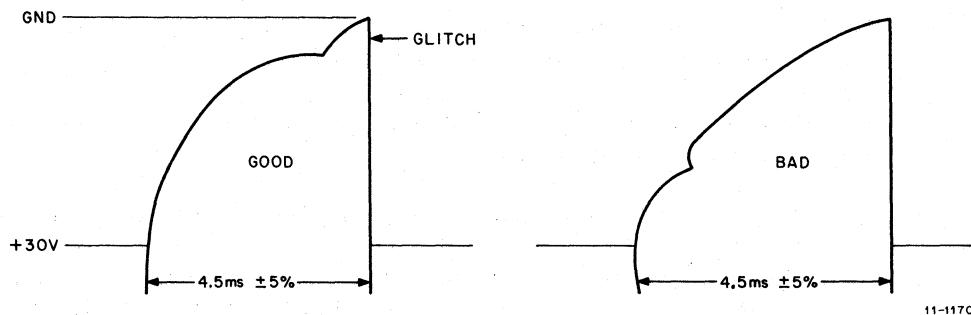

Figure 5-16 Punch Solenoid Waveform

5.5.2 Low Tape Adjustment

NOTE

The low tape adjustment is not required when the system is equipped with a PA68F.

The low tape adjustment procedure is:

1. Load the following program into location 7000:

7000/	7604	OSR
	6314	PSC
	7200	CLA
	7001	IAC
	6311	SKPNA
	5207	JMP .2
	5203	JMP -.3
	6026	PLS
	6021	PSF
	5210	JMP -.1
	5203	JMP -.7

2. Set the control switch on the punch to OFF.
3. Install a tape spool on the punch, containing approximately 1/2 in. of paper tape left on the core.
4. Set SR to starting address (7000) and depress LOAD ADD.
5. Set SR bits 8 through 11 to punch N⁰ and depress START. The program should index the AC, indicating that the punch is not available. If a tape is punched, there is an error.
6. Set the control switch on the punch to CONTINUOUS and STOP WHEN DONE. The indication described in step 5 should be obtained.
7. Set the control switch to AVAILABLE. A binary count pattern should be produced in the tape.
8. Remove the 1/2 in. tape spool and install a tape spool containing approximately 3/8 in. of paper tape left on the core. The NO TAPE lamp on the PA63 should light when the program is restarted and the punch should stop producing the binary count pattern, indicating that the punch is not available (out-of-tape). If tape is punched, loosen the two screws holding the low tape switch on the punch and move the switch until the punch stops and the NO TAPE light on the PA63 goes on. Tighten the screws and check that the punch is still not producing tape and the NO TAPE light remains on.

5.6 4 ms CHANGE READER DELAY

The purpose of the 4 ms change reader delay adjustment is to set the period of delay between reader selection and the time that the first character is read. An oscilloscope is required to make this adjustment. The adjustment procedure is:

1. Load the following program into location 0200:

0200/	7200	CLA
	6312	RSC
	2220	ISZ TEMP
	5202	JMP -.1
	5200	JMP -.4

2. Set SR to starting address 0200, depress LOAD ADD and START.
3. Connect the oscilloscope to A26F2.
4. Adjust potentiometer R2 on M302 (Figure 5-17) to obtain the waveform shown in Figure 5-18.

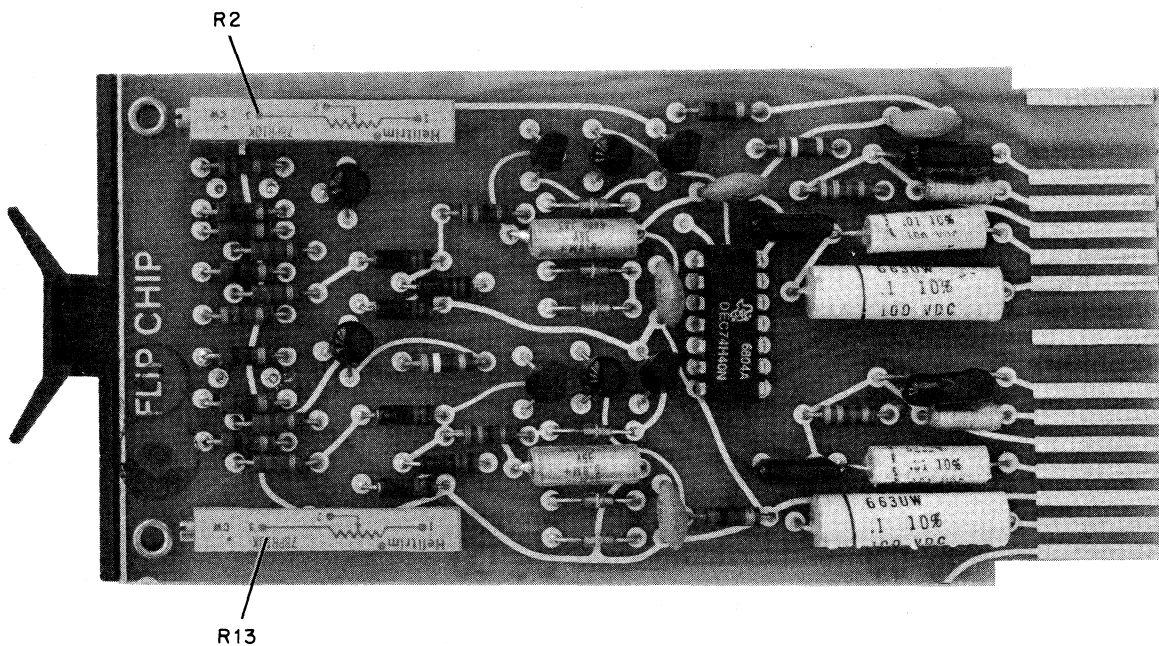
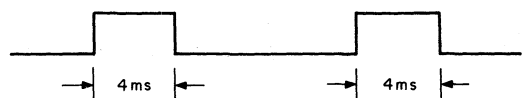

Figure 5-17 M302 Dual Delay Multivibrator Module



08-0776

Figure 5-18 Change Reader Delay Waveform

5.7 1 SECOND CHANGE PUNCH DELAY

The purpose of this adjustment is to set the period of delay between punch selection and the time the punch motor reaches full speed. An oscilloscope is required to make this adjustment. The adjustment procedure is:

1. Load the following program into location 0200:

0200/	6314	PSC
	7402	HLT
	5200	JMP .-2

2. Set SR to starting address 0200, depress LOAD ADD and START.
3. Connect the oscilloscope to A26T2.
4. Adjust potentiometer R13 on M302 to obtain the waveform shown in Figure 5-19. Depress CONT when the program halts to keep the punch running until the adjustment is completed.

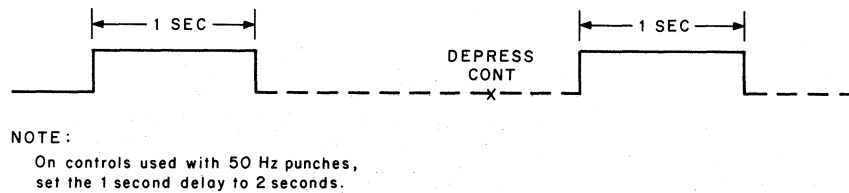

08-0777

Figure 5-19 Change Punch Delay Waveform

5.8 MIXED TAPE LEVELS

Some systems must be capable of reading both 6- and 8-level tape. Where both tapes are advanced feed hole, the procedure is the same as described above except that the check for skew should be made between hole 0 and hole 7 (B28C1 on the PA63 or B10C1 on the PA68F).

When the 8-level tape is center feed hole, it has been found to be better, where possible, to reserve a reader for reading 8-level tape only. If this is not practical, the readers should be set up for 6-level tape and then a marginal re-adjustment of the sprocket wheel should be made, together with re-margining of the potentiometer, to accommodate both tape levels.

When all readers have been set up satisfactorily, do a final check, using either the Typesetting Configuration MAINDEC-08-D2HB or the TCSE.

CHAPTER 6

MAINTENANCE

6.1 TEST EQUIPMENT AND DIAGNOSTIC PROGRAMS

The tools and test equipment required for testing and repairing the hardware are listed in Table 6-1.

Table 6-1
Test Equipment and Tools

Equipment	Item	Type
Test Equipment	Oscilloscope Volt-Ohmmeter	Tektronix Model 453 (or equivalent)
Devices	Extender Boards	One W985 double-extender board Two W980 single-extender boards
Tools	Tool Box Paper-Tape Gauge	DEC Field Service DEC Part No. 18-09211

The maintenance philosophy for Positive Logic Typeset-8 Systems is based on system checkout using test programs and manual adjustments. The diagnostic programs supplied by DEC can be used to verify normal operation of the hardware or to indicate possible causes of malfunction. These programs and the corresponding documents are listed in Table 6-2.

Table 6-2
Diagnostic Programs

Program Number	Document Number	Title
DEC-08-D2HC-PB DEC-08-D7CA-PB1 DEC-08-D7CA-PB2	DEC-08-D2HC-D DEC-08-DC7A-D	Family of 8 Typesetting Configuration Test Typeset-8 System Exerciser (TSCE)
MAINDEC-X8- Module No.— Rev. No. -PB	MAINDEC-X8- DIQAB-A-D	Family of 8 Systems Exerciser
MAINDEC-08- D2UA-PB	MAINDEC-08-D2UA-D	PA60C Diagnostic

The Family-of-8 Typesetting Configuration Tests consist of a package of programs used to test and adjust the PP67C/D Punch, the PR68B Reader, the PR68D/DA Reader, and the associated control logic, individually and together. Any one of up to 16 readers or 16 punches can be tested. There are 14 individual programs in the package; these programs and their suggested uses are listed in Table 6-3.

Table 6-3
Typesetting Configuration Test Programs

Program No.	Title	Suggested Use
PRG0	Basic Reader and Reader Control Logic Test	Preliminary Test
PRG1	Basic Punch and Punch Control Logic Test	Preliminary Test
PRG2	Reader Test. Binary Count Pattern	Preliminary Test
PRG3	Punch Test. Binary Count Pattern	Preliminary Test
PRG4	Punch Verify. Binary Count Pattern	Preliminary Test
PRG5	Punch Test. Random Characters	Final Test
PRG6	Punch Verify. Random Characters	Final Test
PRG7	Combined Reader and Punch Test. Binary Count Pattern	Preliminary Test Only
PRG10	Read Amplifier Adjustment Loop	Preliminary Test
PRG11	Read 6, stall 40 ms, reader adjustment loop	Preliminary Timing Test
PRG12	"Change Reader Unit" delay and adjustment loop	Preliminary Adjustment
PRG13	Continuous punch loop	Preliminary data transfer Test
PRG14	1s and 0s test tape generator	Generate Test Tape for PRG10
PRG15	"Punch Out of Tape"	Preliminary adjustment Switch adjustment loop

The Typeset-8 System Exerciser (TSCE) is intended as a tool for verifying the operating ability of the hardware in a typesetting system. It also serves as the normal means of determining system acceptance.

The TSCE program exercises the system hardware simultaneously. It is not intended for use as a diagnostic program for individual peripherals. The purpose of the program is to ensure proper system interaction between peripherals that have previously been tested using the individual diagnostics, thus assuring proper performance of the complete system configuration. The program overlays and intended use of each overlay is listed in Table 6-4.

Table 6-4
System Exerciser Overlays

Overlay	Intended Use
0	Preliminary check of Reader/Punch Selection Logic
1	Preliminary check of Reader/Punch Data Logic
2	Preliminary check of DECTape/DECdisk interaction
3	Final check of System Performance, including Line Printer

The Family-of-8 Systems Exerciser (DEC/X8) is a powerful expandable modular software system dedicated to testing Family-of-8 hardware in a system environment. The structure of DEC/X8 enables the user to design a unique operational exerciser consistent with his needs and the hardware configuration.

A minimum of 4K of memory is required; however, certain capabilities cannot be used unless the system is equipped with at least 8K of memory. The unusable features are noted in the program document. DEC/X8 can be used with up to 32K or memory.

NOTE

DEC/X8 does not currently (August 1972) have a specific module for Typeset-8 Systems. However, existing modules can be used to verify the performance of Typeset-8 Systems.

Existing modules are described in the program document.

6.2 PREVENTIVE MAINTENANCE

Preventive maintenance comprises tasks performed at periodic intervals to ensure proper equipment operation and minimum unscheduled downtime. These tasks consist of visual inspection, operational checks, cleaning, lubrication, adjustment, and replacement of borderline or partially defective parts.

Preventive maintenance procedures for all Typeset-8 Systems are provided in a separate document published by Field Service. Refer to the current document to obtain the latest policies and procedures.

6.3 SPARE PARTS

Recommended spare parts for all Positive Logic Typeset-8 Systems are listed in Table 6-5. Replaceable parts are listed and illustrated in Volume 2 for all DEC-manufactured hardware. The part numbers provided for the PR68B High-Speed Paper-Tape Reader are incorrect. The correct part numbers are listed in Table 6-6 according to find number (item number).

Table 6-5
Typesetting Spares

PR68B Readers		
Part	Quantity	DEC Number
Condensing Lens 1-3/16 inch	2	74-4989
Photocell Head Assembly	1	29-15961
Switch	1	74-4992
Tape Depressor Spring	2	74-4984
Osram Bulbs 12V, 10W	4	12-4734
Light Bulb 330	4	12-2986
Toggle Switch (Subminiature)	2	12-1168
G900 (PR68A)	1	"NTTA"
or G908 (PR68B)	1	
PR68D/DA Readers		
Condensing Lens 1-3/16 inch	2	74-4989-1
Photo Transistor Block	2	70-6592
Tape Depressor Spring	2	74-7719
Osram Bulb #6475	4	12-4734
GE Bulb #1445	4	12-9744
G918 (D and DA)	1	
G930 (D only)	1	
Switch, Momentary	1	12-5375 (PR68D)
or Switch, On/Off	1	12-5941 (PR68DA)
PP67C/D Punches		
Diode Pack MDA952-5	1	11-5280
Switch T206	1	12-3374
Thyrector 6 RS 20S94-B4	1	11-0106
SCR C20B	2	11-1820
Diode MR2064	2	11-3183
Resistor 25Ω 10W	2	29-13340
Solenoid Magnets	2	29-16402
Punch Block		
6 level (PP67C)	1	29-11210
8 level (PP67D)	1	29-11199
G915 Module	1	-

Table 6-5 (Cont)
Typesetting Spares

Interfaces,	Modules	Quantity
PA63	M710	1
	K303	1
	M060	2
	M216	1
	M624	1
	M161	1
	M623	1
	M401	1
PA68F	M710	1
	M060	2
	M401	1
	M623	1

Table 6-6
Parts List For PR68B

Item No.	Part No.	Item No.	Part No.
1	7404983	28	9007649
2	9006022-1	30	7404977
3	9006560	31	7404986
4	7404992	32	7006337
5	7404984	33	9006020-1
6	12-4747	34	7404989
7	9006003-1	36	7404989
10	9006027-1	37	7404979
12	7404976	38	12-4734
13	7404991	39	7404980
14	9006046-2	40	12-4614
15	74-4975	41	12-4713
16	7404982	45	9006022-2
17	7404988	46	9006026-1
18	7404978	50	7405595
19	12-3530	52	7406675
20	9006024-1	53	12-2986
21	74-4985	54	12-4628
22	9107684	55	90-06901
24	7404981	56	91-07350-4
25	7404974	57	91-07400-5
26	7404990	58	7407338-0-0
27	9006656	60	7005893-0-0

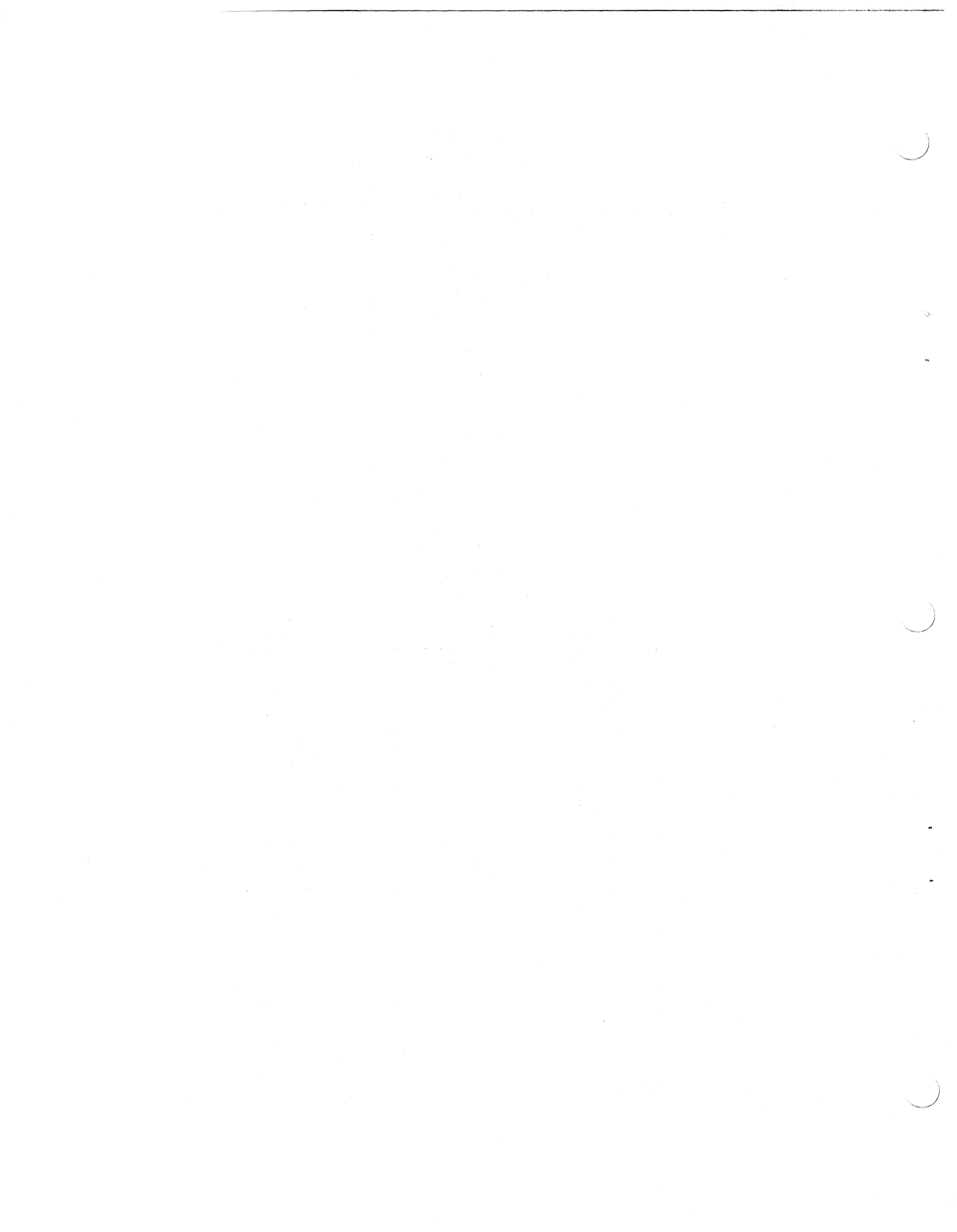

APPENDIX A

GLOSSARY OF TERMS

The following pages contain a glossary of terms commonly used in the printing, graphic arts, and newspaper fields. This glossary is designed to provide DEC maintenance personnel with a basic understanding of the terminology used in these areas. Hopefully, this may lead to improved communication and a better understanding of the problems encountered in those areas using the Typeset-8 System.

Agate line	A standard of measurement for depth of columns of advertising space. Fourteen agate lines make one column inch.
Alterations	In composition, changes made in the copy after it has been set in type.
Ascender	That part of the letter which rises above the main body, as in "b".
Automatic allotting	Distribution of output tape codes to punches according to copy style.
Backing up	Printing the reverse side of a sheet already printed on one side. In electrotyping, backing a copper shell with metal to make the plate the required thickness.
Bad break	In composition, the setting of a hyphenated line as the first line of a page. Also, incorrect word division.
Bands program	A program that uses space bands to justify lines of hot type.
Base	In composition, all the metal below the shoulder of a piece of type. In letterpress, the metal or wood block on which printing plates are mounted to make them type high.
Base line	An imaginary line used as a reference in the measurement of leading. Alphanumeric characters sit on this line, descenders go below this line for example: <u>Quertyoip: p's are queueing for signatures.</u>
Basis weight	The weight in pounds of a ream (500 sheets) of paper cut to a given standard size for that grade: 25 X 38 for book papers, 20 X 26 for cover papers, 22 1/2 X 28 1/2 or 22 1/2 X 35 for bristols, 25 1/2 X 30 1/2 for index, e.g., 500 sheets 25 X 38 of 80-lb coated will weigh eighty pounds.
Bearer	In photoengraving, the dead metal left on a plate to protect the printing surface while molding. In composition, type-high slugs locked up inside a chase to protect the printing surface. In presses, the surface-to-surface ends of cylinders that come in contact with each other.
Benday	A method of laying a screen (dots, lines and other textures) on artwork or plates to obtain various tones and shadings.

Bite	In photoengraving, the various stages of standard etching accomplished through the action of acid, the depth increasing after each bite.
Blanket	In offset-lithography, a rubber-surfaced sheet clamped around the cylinder, which transfers the image from plate to paper.
Blueprint	In offset-lithography and photoengraving, a photoprint made from negatives or positives, used as a proof.
Body	A term referring to the viscosity, consistency, or covering power of an ink or vehicle.
Bold-face type	A name given to type that is heavier than the text type with which it is used.
Break for color	In artwork and composition, to separate the parts to be printed in different colors.
Bulk	The degree of thickness of paper.
Burnishing	In photoengraving, the corrective treatment of a printing plate to darken local areas by spreading the printing surface of lines and dots.
Burr	Rough edges of metal caused by routing or cutting.
Caliper	The thickness of paper, usually expressed in thousandths of an inch.
Caps and small caps	Two sizes of capital letters made in one size of type, commonly used in most roman type faces.
Carbro	A photograph in full color, frequently used for process color reproduction.
Chase	A rectangular metal frame in which type and plates are locked up for printing.
Chicken plucker	Small hand tool for modifying or correcting paper tape codes.
Cold type	See photocomposition.
Collate	In binding, the assembling of sheets or signatures.
Combination plate	In photoengraving, halftone and line work combined on one plate; etched for both halftone and line depth.
Column indent	A format in which all lines in a column are indented from the flush position.
Comet	Trade name linecaster (See Electron)
Composing stick	In composition, a hand tool in which type is assembled and justified.
Condensed type	A narrow or slender type face.
Continuous tone	A photographic image which has not been screened and contains gradient tones from black to white.
Copy	Any furnished material (typewritten manuscript, pictures, artwork) used in the production of printing.
Curved plate	In letterpress, an electrotype or stereotype which is backed up and pre-curved to fit the cylinder of a rotary press.
Cut	In letterpress, a photoengraving of any kind.

Cutscore	In die-cutting, a sharp-edged knife, usually several thousandths of an inch lower than the cutting rules in a die, made to cut part way into the paper or board for folding purposes.
Densitometer	A sensitive photoelectric instrument which measures the density of photographic images, or of colors in color printing. Used in quality control to determine accurately whether color is consistent throughout the run.
Descender	That part of the letter which extends below the main body, as in "p".
Display type	In composition, type set larger than the text, used to attract attention.
Distribution	In composition, the act of returning type, rules, leads, slugs, furniture, and other printing materials to their proper places after use.
Doctor blade	In gravure, a knife-edge blade pressed against the engraved printing cylinder which wipes away the excess ink from the non-printing area.
Dot	The individual element of a halftone.
Double dot halftone	Two halftone negatives combined into one printing plate, having greater tonal range than a conventional halftone. One negative reproduces the highlights and shadows; the other reproduces middletones. Used primarily in offset-lithography.
Drier	In inkmaking, any substance added to hasten drying.
Dropout	A halftone with no screen dots in the highlights.
Dummy	A "preview" of a proposed piece of printing.
Duotone	In photomechanics, a term for a two-color halftone reproduction from a one-color photograph.
Dump punch	A tape punch used to output a tape when the allotted punch cannot be used.
Dropped rule	A straight type-high ruling slug often used to separate classified advertisements. See example below.
<p><small>BABYSITTER needed. Once a week on Thursday 11 a.m. to 11 p.m. for one 6 yr. old girl. Agency fee rate paid + transportation. Call PL 54321 bef. 9 a.m. any morning.</small></p> <p><small>HOUSEKEEPER, steady & dependable, short hours, 5 days per week. Weekly salary. Must have car. 791-8762.</small></p> <p><small>BABYSITTER needed nites. 5 days a week, 3:15 - 12:30. Call 365-6605.</small></p> <p><small>LIGHT housekeeping & some cooking for elderly people. Live in Lcs Altos. \$150 month. 948-4598 or 812-7649.</small></p>	
Reprinted by permission of the Worcester Telegram and Gazette.	
Electron	Trade name for a linecaster similar to the Linotype; operates in the 6 to 9 pt range.
Electron mixer	Same as Electron but capable of mixing up to four fonts in the 6 to 24-point range.
Em	In composition, the square of a type body. So named because the letter "M" in early fonts was usually cast on a square body.
En	One-half the width of an em.
Engraving	A general term applied to any printing plate produced by an etching or cutting process.

Escapement	The distance that a carriage or lens mechanism moves for a character.
Etch	In photoengraving, to produce an image on a plate by chemical or electrolytic action. In offset-lithography, an acidified gum solution used to desensitize the non-printing areas of the plate; also, an acid solution added to the fountain water to help keep non-printing areas of the plate free from ink.
Expanded type	Type whose width is greater than normal; also called extended type.
Face	The printing surface of a piece of type.
Feeder	The section of a press which separates the sheets and feeds them in position for printing.
Filling in (or filling up)	A condition in letterpress or offset-lithography where ink fills the area between the halftones dots or plugs up the type.
Flat	In offset lithography, the assembled composite of negatives or positives, ready for platemaking. Also, a picture that is lacking in contrast.
Flow	The ability of an ink to spread over a surface or into a thin film.
Flush and Hang	A printing format in which the first line of text is set flush with the left margin with all following lines indented. See example below.

WSRS-FM
WORCESTER-96.1 mcs

A.M.
6:00--STEREO AT DAYBREAK: Claus Ogerman; Andre Kostelanetz; Howard Roberts Quartet; Anthony Newley; Enoch Light; Norman Luboff Choir.
9:00--STEREO MAGIC: Tony Bennett; Edmundo Ros; Peter Nero; Doris Day; Andre Kostelanetz; Ray Conniff.

P.M.
12:00--STEREO SHOWCASE: Peter Nero; Matt Monro; Werner Muller; Rodgers and Hart; Ronnie Aldrich; Teresa Brewer; Henry Mancini; 101 Strings; Enoch Light; Mel Davis.
5:00--STEREO SPECTRUM: Andre Previn; Jackie Gleason; Anita Bryant; George Shearing; Mantovani; Edmundo Ros.
8:00--BEST OF BROADWAY: Ray Conniff; Andre Previn; 101 Strings; Living Strings.
10:00--TONIGHT ON POPS: Richard Tucker; A Pops Concert with various artists; Eugene Ormandy; Athens.
12:00--STEREO TILL SIX: Living Trio; Hollywood Bowl Symphony; Glen Gray; Nat King Cole; Frankie Carle; Enoch Light; Bob Eberly; and Helen O'Connell; Exodus (soundtrack); Webley Edwards; Aretha Franklin; Cozy Cole; McGuire Sisters.

Reprinted by permission of the Worcester Telegram and Gazette.

Flush blocking	Mounting a plate so that the printing surface is flush with the edge of the block.
Flush left (or right)	In composition, type set to line up at the left (or right). This glossary of terms is set flush left.
Flush paragraph	A paragraph with no indentation.
Flying paster	In web printing, an automatic pasting device that splices a new web of paper onto an expiring roll, without stopping the press.
Font	A complete assortment of type of one size and face. In hot metal, a font is stored in a magazine. In photocomposition, a font is stored in a masking device such as a disk, film strip or grid; or digitized and stored on disks, in core memory, magnetic tape, etc., as in video display photocomposition machines.

Form	Type and other matter locked in a chase ready for printing.
Form rollers	The rollers, either ink or dampening, which contact the plate.
Format	The size, style, type page, margins, printing requirements, etc., of any magazine, catalog, book, or printed piece. Also, a predefined sequence of codes or code strings used to simplify mark-up and or reduce key-strokes.
Furniture	In lockup, wood or metal blocks used to fill the blank spaces in a form.
Fuzz	Fibers projecting from the surface of a sheet of paper.
Galley	A shallow metal tray used to hold type.
Galley proof	A proof taken of type standing in a galley, before being made up into pages.
Gathering	The assembling of folded signatures in proper sequence.
Grippers	Metal fingers which hold the paper in place to the delivery end of a press.
Gripper edge	The leading edge of paper as it passes through a printing press.
Gripper margin	Unprintable blank edge of paper on which grippers bear, usually 1/2 inch or less.
Gutter	The blank space or inner margin, from printing area to binding.
Half-column cut	A photoengraved illustration, one-half column in width, inserted into a column of text. Also called a run-around. See example below.

Dr. Andras Fabry, a member of the Royal College of Veterinary Surgeons, has been appointed to the department of pharmacology and toxicology of Mason Research Institute, 21 Harvard St., it has been announced.



Dr. Fabry studied veterinary medicine in Liverpool, England, from 1956 to 1962 and did postgraduate work anaesthetics at the University of Glasgow.

Reprinted by permission of the Worcester Telegram and Gazette.

Halftone	A reproduction of continuous tone artwork, such as a photograph, with the image formed by dots of various sizes.
Head margin	The white space above the first line on the page.
Hickeys	In offset-lithography, an imperfection in presswork due to many things such as dirt on the press, hardened by specks of ink, etc.
Highlight	The lightest or whitest parts in a printed picture, represented in a halftone by the smallest dots or the absence of all dots.
Hot-metal equipment	A class of machines producing lines of type (slugs) used in the making of type cylinders for newspaper printing.
Imposition	The laying out of type pages in a press form so that they will be in the correct order after the printed sheet is folded.

Impression	In printing, the pressure of type or plate as it comes in contact with the paper.
Ink fountain	The container which supplies ink to the inking rollers.
Insert	A specially printed piece usually prepared for insertion in a publication.
Intaglio printing	Printing from plates in which the image is in intaglio or sunken below the surface, such as in steel-plate engraving or gravure.
Justify	In composition, to space out lines uniformly to the correct length.
Kerning	Reduction of character escapement in order to condense words or lines of text—used primarily in conjunction with larger point sizes.
Key	To code copy to a dummy by means of symbols, usually letters. Insertions are sometimes “keyed” in a like manner. In lockup, a device for operating quoins.
Key plate	In color printing, the plate used as a guide for the register of other colors. It normally contains the most detail.
Layout	The drawing or sketch of a proposed printed piece.
Leaders	In composition, rows of dashes or dots used to guide the eye across the page. Used in tabular work, programs, tables of contents, etc.
Leads	Thin strips of metal placed between lines of type to separate them vertically.
Leading	The amount of vertical space from baseline to base—in typeset copy.
Letterspacing	The spacing between each letter of a word.
Letter press	The process of printing directly from an inked raised surface upon which the paper is impressed.
Linecasting machines	Any of a group of keyboard and/or perforated-tape controlled devices which cast lines of lead type (slugs) using brass mats (matrices) as molds.
Linotype	Trade name for a hot-metal linecasting machine controlled from a keyboard or paper tape; operates in the 6 to 14 pt range.
Lockup	In letterpress, to position a form in a chase for printing.
Logotype (or logo)	Name of a company or product in a special design used as a trademark in advertising.
Long ink	An ink that has good flow in the fountain.
Loose lines	Lines in which the total width of the mats used is less than the preset line length. When this occurs, the linecaster will not mold a slug.
Lower case	The small letters in type, as distinguished from the capital (upper case) letters.
Ludlow	Trade name for a manually operated linecaster which produces type slugs from hand-set type mats.
Magazine	In hot-metal typecasting equipment, a container, usually mounted at the top of the equipment, from which type-molding mats are automatically drawn to produce type slugs.
Makeready	In letterpress, the building up of the press form so that heavy and light areas print with the correct impression.

Makeup	In composition, the arrangement of lines of type and illustrations into pages of proper length.
Mask	In color separation photography, an intermediate photographic negative or positive used in color correction. In offset-lithography, opaque material used to protect open or selected areas of printing plates during exposure.
Masking paper	In offset-lithography, goldenrod paper to which negatives are fastened in stripping to produce a flat.
Mat	Newspaper term for a matrix.
Matrix	A mold in which type is cast in linecasting machines. In stereotyping, the paper mold made from a type form.
Measure	In composition, the width of type, usually expressed in picas.
Middletones	The tonal range between highlights and shadows of a photograph or reproduction.
Mixing	The process by which mats are drawn from different magazines on a single linecaster to produce distinctive printing formats; as in advertisements. See example of four-magazine mixing below.



	Reprinted by permission of the Worcester Telegram and Gazette.
Moire	Undesirable screen pattern in color process printing caused by incorrect screen angles of halftones.
Mottle	The spotty or uneven appearance of printing. Most pronounced in solid areas.
Newsprint	A generic term used to describe the kind of paper generally used in the publication of newspapers.
Nickeltype	In electrotyping, a plate on which the first deposit is of nickel and the remainder of the shell is copper. Nickeltypes give sharper definition in printing and are more durable than copper.
No-Bands program	A program that uses fixed spacing and the auto-quadding features of a linecaster to justify lines of hot type.
Offset printing	A printing process in which an inked impression from a planographic surface is first made on a rubber-blanketed cylinder and then transferred to the paper being printed.
Opaque	In photoengraving and offset-lithography, to paint out areas on a negative not wanted on the plate. In paper, the property which makes it less transparent.

Overlay	In letterpress makeready, a piece of paper placed in the packing to make that part of the form print more heavily. In artwork, a transparent or translucent covering over copy where color break, instructions, or corrections are marked.
Overprinting	Double printing; printing over an area that already has been printed.
Overset	In composition, type set in excess of space needs in publications.
Paragraph indent	A format in which the initial line of a paragraph is indented with the balance of lines flush left.
Pasteup	The preparation of copy for photographic reproduction by putting all elements in the proper position.
Patent base	In letterpress, a slotted metal base on which unmounted electrotypes are secured.
Perfecting press	A press which prints both sides of paper at one time.
Photocomposition	A process by which reproducible page masters are photographically produced.
Photocomposition machine	A device that produces and composes type photographically. See following:

C/A/T – Used for on-line text and limited display composition with direct computer drive; operating range is 6 to 36 pt in 15 sizes. It contains four completely independent font segments at a time. Each font contains up to 102 characters.

Compugraphic 4962 – Used for mixed text and display composition. Type can be set from a film strip containing four 90-character fonts.

Compstar 191 – Used for high-speed text and display composition; operates in the 5 1/2 to 48 pt range. Machine has eight lenses and a dual lensing feature that produces 15 point sizes.

Fototronic 480/1200 – Text and display composition. Type Sizes range from 5 to 72 pt depending upon disk size, in 19 sizes. Each type disk contains two, 120-character fonts, with five disks on the machine at one time. Font capacity leaves 30 extra locations for storing pi characters, accents, or other special characters.

Fototronic TxT – Similar to the Fototronic 480/1200. The differences are:

1. It is primarily a text-oriented machine with some display capabilities. Type size range is from 5 to 36 pts in 15 sizes.

2. It uses a 12-position lens turret that puts up to 12 sizes of type on a line at the same time, instead of the zoom lens optical system used in the 480/1200.
3. Light source is an xenon lamp instead of a plasma jet.

Photon 513 – Used in display composition; operates in the 6 to 72 pt range.

Photon 532 – Computer slave used in text and display composition; operates in the 4 1/2 to 72 pt range, in 23 sizes from two matrix disks containing 32 90-character type faces (16 per disk).

Photon 560 – Similar to the 513.

Photon 561 – Similar to the 532. The 561 has only one glass matrix disk instead of two. It holds 16 90-character typefaces rather than 32. It can produce 12 type sizes for each face from the lens turret which does not have the minifier lens that gives the 532 23 sizes. Type size range is 5 to 72 pts.

Photon 713-5 – Used in text and limited display composition; operates in the 5 to 18 pt range, with two sizes and four faces. A single film strip contains four 96-character fonts.

Photon 713-10 – Used in straight text and limited display composition; operates in 5 to 36 pt range, with font strips carrying 8 96-character type faces in 8 sizes. Strips can be arranged singly or in duplexed pairs.

Photon 713-20 – Similar to 713-10.

Photon 713-100 – Similar to 713-10, but faster.

Photon 713-200 – Similar to 713-100, but even faster. It has a 4K mini-computer for memory.

Pacesetter – Used in high-speed text and display composition. Operates in 5 to 72 pt range. The number of typefaces and sizes depends on the model, e.g., Pacesetter 45 has four faces in five sizes. Customer selects up to 16 sizes, depending on specific requirements. A fully programmable 8K mini-computer provides the control logic and gives the Pacesetter far greater format storage capacity than the 713 series.

Linofilm – Used in text and display composition. Operates in the 6 to 54 pt range in five grid ranges. Enlargement and reduction capabilities extend the range from 4 to 216 points. Each grid contains 88 characters.

Linofilm Quick – Used in straight text composition; operates in the 6 to 18 pt range.

Linofilm Superquick – There are three versions of this machine; two standard models and a wide range model. Standard models are available in two or four-grid configurations; operating range is 5 to 18 pt. The wide-range model has four grids with an operating range from 5 to 72 pts, making it both a text and display composition machine.

V-I-P – Primarily a text composition machine; operates in the 6 to 48 pt range. It can mix up to 6 96-character fonts in 16 sizes. A display attachment extends the range to 96 pts.

Pi	Type mixed and in an unusable condition.
Pica	Printer's unit of measurement used principally in measuring lines. One pica equals 1/6 of an inch.
Pica pole	See type gauge.
Picking	The lifting of the paper surface during printing. It occurs when pulling force (tack) of ink is greater than surface strength of paper.
Piling	The building up or caking of ink on rollers, plate or blanket; will not transfer readily.
Point	Printer's unit of measurement, used principally for designating type sizes. There are 12 points to a pica; 72 points to an inch.
Primary colors	In printing inks, yellow, magenta (process red) and cyan (process blue). In light, the primary colors are red, green, and blue.
Process printing	The printing from a series of two or more halftone plates to produce intermediate colors and shades. Usually in four-color process: yellow, red, blue, and black.
Progressive proofs	Proofs of each individual plate in a set of color process plates, pulled in the proper colored inks, and also showing the results of adding each color.
Quad	In composition, blank spacing material less than type high used to fill out lines.
Quoin	In letterpress, steel wedge-shaped or expanding devices used in lockup.
Register	Fitting of two or more printing images upon the same sheet of paper in exact alignment with each other.
Register marks	Crosses or other devices applied to original copy prior to photography. Used for positioning negatives in perfect register, or for color register of two or more colors in printing.
Reproduction proof	In composition, the proof of a type form for photographic reproduction.
Reverse plate	A printing plate in which the parts that are usually black or shaded are reversed, so as to appear white or grey.
Routing	Cutting away the non-printing areas of a letterpress plate.
Sans-serif	A typeface having no serifs.
Scale	The proportion between dimensions of an original and its reproduction. Degree of enlargement or reduction.
Scanner	Electronic device designed to read typewritten copy optically.
Score	To impress or indent a mark with a string or rule in the paper to make folding easier.
Screen	In photoengraving and offset-lithography, glass or film with cross-ruled opaque lines or vignetted dots used to reproduce continuous tone artwork such as photographs. Also, the number of lines or dots to the linear inch on printed illustration.
Serif	The short cross-lines at the ends of the main strokes in roman type faces.
Set-off	In presswork, when the ink of a printed sheet rubs off or marks the next sheet as it is being delivered. Formerly called offset.

Set size	An increase or decrease in character escapement to expand or condense words or lines of text.
Shadow	The darkest parts in a photograph, represented in a halftone by the largest dots.
Short ink	An ink that does not flow freely.
Signature	In book, magazine and catalog work, the name given to a large printed sheet after it has been folded to the required size.
Slitting	Cutting printed sheets or webs into two or more sections by means of cutting wheels on the press or folding machine.
Slug	In composition, a one-piece line of type. Also a strip of metal, usually 6 points, used for spacing.
Small caps	An alphabet of small capital letters available in most roman type faces approximately the size of the lower case letters. Used in combination with larger capital letters.
Space band	A unit of two thin wedge-shaped pieces of metal used as spacers between the words of a line of hot type. Expandable from approximately a thin space to an En space plus a thin space.
Stet	A proofreader's mark, written in the margin, signifying that copy previously marked for corrections should stand as printed and not be corrected.
Straight matter	Columns of printing containing continuous text matter using the same type style and size. See example below.
	<p>The Worcester Chapter of the Administrative Management Society will hold "Education Night" tomorrow at 6:45 p.m. in the Coach and Six Restaurant.</p> <p>Highlighting the evening's activities will be the awarding of a scholarship to a Worcester area high school student, a panel discussion on "How Are We Preparing Our Young People For Business?", and installation of new officers for the coming year.</p>
	Reprinted by permission of the Worcester Telegram and Gazette.
Strike-through	The penetration of ink through paper.
Stripping	In offset-lithography, the arranging of negatives (or positives) in their proper position on a flat prior to platemaking.
Substance	The weight in pounds of a ream (500 sheets) of paper cut to the standard size (17 X 22) for business papers (bond, ledger, mimeograph, duplicator, and manifold); e.g., 500 sheets of 20-lb bond cut to the standard size will weigh 20 lb.

Tabular matter

Tabulated lists of data, often statistical. See examples of single-, and half-column tabular matter below.

American				National					
	W.	L.	Pct.	GB		W.	L.	Pct.	GB
Chicago	18	7	.720	...	Cincinnati	21	10	.677	...
Detroit	17	9	.654	1½	Pittsburgh	16	9	.640	2
Kansas City	13	14	.481	6	St Louis	15	11	.577	3½
Boston	13	14	.481	6	Chicago	15	11	.577	3½
Cleveland	12	13	.480	6	Atlanta	14	14	.500	5½
New York	12	13	.480	6	San Francisco	14	14	.500	5
Washington	12	15	.444	7	Philadelphia	13	14	.481	6
California	13	17	.433	7½	New York	10	15	.400	8
Minnesota	11	15	.423	7½	Los Angeles	10	17	.370	9
Baltimore	11	15	.423	7½	Houston	8	21	.276	12

FIFTH — \$2,800, Claiming, 3 and 4 year-olds, 6 furlongs.

Blenham	111	Merry Flight	113
Broken Note	113	County C.	111
Me Tarzan	111	Henry W.	107
Mr. Peppercorn	109	Abdicat	118
Madre To M'ket	104	Alex The Fox	116
Winged Action	121	Interstate	118

Thirty

Reprinted by permission of the Worcester Telegram and Gazette

Used in newspapers, the symbol “-30-” means the end of the story.

Thin space

One-quarter to two-thirds the width of En space.

Tight lines

Lines in which the total width of the mats used is too great to fit within the jaws of the linecaster. Often produces a jam.

Transpose

To exchange the position of a letter, word, or line with another letter, word, or line.

Type gauge

A printer's tool calibrated in picas used to measure the various sizes of types.

Type high

0.918 inch; the standard in letterpress printing.

Vacuum frame

In photoengraving and offset-lithography, a printing frame used in plate-making. The negative (or positive) is held in close contact with the plate by vacuum.

Vehicle

The fluid component of printing ink which acts as a carrier for the pigment.

Vignette

An illustration in which the background fades gradually until it blends into the unprinted paper.

Washup

The process of cleaning the rollers, form or plate, and sometimes the fountain of a press.

Web

A roll of paper used in web or rotary presses, printed, and most often folded, pasted and counted in one continuous operation.

Web press

A general term applied to high-speed presses which print from continuous rolls of paper.

Web tension

The amount of pull or tension applied in the direction of travel of a web of paper by the action of a web-fed press.

White space reduction

A technique used on Photon 713 machines to reduce escapement of larger point sizes.

Widow	In composition, a single word in a line by itself, ending a paragraph; frowned upon in good typography.
Wirestripping	The removal and/or conversion of justification and hyphenation codes in wire service tapes to meet the requirements of individual users.
Work-up	In letterpress, a space, lead, or other spacing material which works itself to the surface during printing, normally caused by poor lockup.
Wrap-around plate	In rotary letterpress, a thin one-piece relief plate which is wrapped around the press cylinder; similar in appearance to an offset plate.
Wrong font	In proofreading, the mark "WF" indicates a wrong letter or character in a line.

1. The first part of the document discusses the importance of maintaining accurate records of all transactions.

2. It then goes on to describe the various methods used to collect and analyze data.

3. The next section details the results of the study, showing a clear trend in the data.

4. Finally, the document concludes with a summary of the findings and recommendations for future research.

5. The overall conclusion is that the data strongly supports the hypothesis that was tested.

6. This research provides valuable insights into the complex relationship between the variables studied.

7. The findings suggest that there is a significant correlation between the two factors.

8. The study also highlights the need for further investigation in this area.

9. The results are consistent with previous research in the field.

10. The data indicates that the model used is a good fit for the observed data.

11. The study was conducted over a period of six months.

12. The sample size was large enough to ensure statistical significance.

13. The data was collected from a diverse range of sources.

14. The results are presented in a clear and concise manner.

15. The document is well-organized and easy to read.

16. The findings are supported by a wealth of evidence.

17. The study has important implications for the field.

18. The data shows a strong positive correlation between the variables.

19. The results are consistent across all groups.

20. The study was conducted in a rigorous and scientific manner.

21. The findings are a valuable contribution to the literature.

22. The data is presented in a clear and accessible format.

23. The study is a model of good research practice.

APPENDIX B

ENGINEERING DRAWINGS

B.1 ENGINEERING DRAWINGS

A complete set of engineering drawings and module circuit schematics is provided with each manual in a companion volume entitled, *Typeset-8 System – Positive Logic, Engineering Drawings*. The general logic symbols used on these drawings are described in the *DEC Logic Handbook*, 1971 and 1972.

Table B-1 is a summary of the Master Drawing Lists included in Volume II. Each Master Drawing List provides a detailed index of the specific drawings that are included in Volume II for each unit. Any drawings that are not indexed in a Master Drawing List, but included in Volume II are also included in the index of Master Drawing Lists. To locate a specific drawing for a given unit, refer to the index of Master Drawing Lists first, and then refer to the appropriate Master Drawing List.

Table B-1
Index of Master Drawing Lists

Drawing No.	Title	No. of Sheets
A-ML-PA63-0	Master Drawing List for PA63 16-Channel Reader/Punch Multiplexer	2
A-ML-PA68-F	Master Drawing List for PA68-F Reader/Punch Control and Interface Unit	2
A-ML-PR68-B	Master Drawing List for PR68-B High-Speed Paper-Tape Reader	1
B-CS-G908-0-1	G908 Photoamplifier Module	1
A-ML-PR68-D	Master Drawing List for PR68-D High-Speed Paper-Tape Reader	2
A-ML-PR68-DA	Master Drawing List for PR68-DA High-Speed Paper-Tape Reader	2
A-ML-PP67-C	Master Drawing List for PP67-C High-Speed Paper-Tape Punch	2

Table B-1 (Cont)
Index of Master Drawing Lists

Drawing No.	Title	No. of Sheets
A-ML-PP67-D	Master Drawing List for PP67-D High-Speed Paper-Tape Punch	2
C-CS-G773-0-1	Cable Connector	1
A-PL-PA63-0-14	Module Utilization Parts List	1
A-PL-PA68-F-5	Module Utilization Parts List	1

READER'S COMMENTS

**TYPESET-8 SYSTEMS
POSITIVE LOGIC MAINTENANCE MANUAL
DEC-08-HMMPA-A-D**

Your comments and suggestions will help us in our continuous effort to improve the quality and usefulness of our publications.

What is your general reaction to this manual? In your judgment is it complete, accurate, well organized, well written, etc.? Is it easy to use? _____

What features are most useful? _____

What faults do you find with the manual? _____

Does this manual satisfy the need you think it was intended to satisfy? _____

Does it satisfy *your* needs? _____ Why? _____

Would you please indicate any factual errors you have found. _____

Please describe your position. _____

Name _____ Organization _____

Street _____ Department _____

City _____ State _____ Zip or Country _____

Fold Here

Do Not Tear - Fold Here and Staple

**FIRST CLASS
PERMIT NO. 33
MAYNARD, MASS.**

**BUSINESS REPLY MAIL
NO POSTAGE STAMP NECESSARY IF MAILED IN THE UNITED STATES**

Postage will be paid by:

**Digital Equipment Corporation
Technical Documentation Department
146 Main Street
Maynard, Massachusetts 01754**

