

Copyright Information

Copyright © 2009 Internetwork Expert, Inc. All rights reserved.

The following publication, CCNP Lab Workbook, was developed by Internetwork Expert, Inc. All rights reserved. No part of this publication may be reproduced or distributed in any form or by any means without the prior written permission of Internetwork Expert, Inc.

Cisco®, Cisco® Systems, CCNP, and Cisco Certified Network Professional, are registered trademarks of Cisco® Systems, Inc. and/or its affiliates in the U.S. and certain countries.

All other products and company names are the trademarks, registered trademarks, and service marks of the respective owners. Throughout this manual, Internetwork Expert, Inc. has used its best efforts to distinguish proprietary trademarks from descriptive names by following the capitalization styles used by the manufacturer.

Disclaimer

The following publication, CCNP Lab Workbook, is designed to assist candidates in the preparation for Cisco Systems' CCNP certification exams. While every effort has been made to ensure that all material is as complete and accurate as possible, the enclosed material is presented on an "as is" basis. Neither the authors nor Internetwork Expert, Inc. assume any liability or responsibility to any person or entity with respect to loss or damages incurred from the information contained in this workbook.

This workbook was developed by Internetwork Expert, Inc. and is an original work of the aforementioned authors. Any similarities between material presented in this workbook and actual CCNP exam material is completely coincidental.

Table of Contents

About This Workbook	1
How To Use This Workbook.....	2
Hardware Requirements.....	3
Physical Devices Specification.....	3
Physical WAN Cabling	4
Physical LAN Cabling.....	5
Software Versions	6
Purchasing Equipment	7
Online Rack Rentals.....	8
Dynamips, Dynagen, & GNS3	9
Initial Configurations	10
Support Resources.....	10
Building Cisco Multilayered Switched Networks (BCMSN)	11
Case Study Overview	11
DBM Inc. Campus Diagram.....	12
1.1 VLANs	13
1.2 Access Ports	14
1.3 ISL Trunk Ports	15
1.4 802.1Q Trunk Ports	15
1.5 Controlling Traffic over Trunk Ports.....	16
1.6 VLAN Trunk Protocol (VTP)	16
1.7 VTP Pruning.....	17
1.8 VTP Transparent Mode	17
1.9 Spanning-Tree Protocol.....	18
1.10 Rapid PVST+.....	18
1.11 Multiple Spanning-Tree Protocol	19
1.12 Spanning-Tree Protocol Features	19
1.13 EtherChannel	20
1.14 Inter-VLAN Routing	21
1.15 Port Security.....	22
1.16 802.1X Authentication	22
1.17 VLAN Access Lists	23
1.18 DHCP Snooping & DAI.....	23
1.19 Private VLANs	23
DBM Inc. Gateway Redundancy Diagram	24
1.20 HSRP	25
1.21 VRRP	26
1.22 GLBP	26
BCMSN Solutions.....	27
1.1 VLANs	27
1.2 Access Ports	29
1.3 ISL Trunk Ports	33

1.4	802.1Q Trunk Ports	38
1.5	Controlling Traffic over Trunk Ports	42
1.6	VLAN Trunk Protocol (VTP)	43
1.7	VTP Pruning	47
1.8	VTP Transparent Mode	51
1.9	Spanning-Tree Protocol.....	53
1.10	Rapid PVST+.....	57
1.11	Multiple Spanning-Tree Protocol	61
1.12	Spanning-Tree Protocol Features	65
1.13	EtherChannel	67
1.14	Inter-VLAN Routing	73
1.15	Port Security.....	77
1.16	802.1X Authentication	79
1.17	VLAN Access Lists	81
1.18	DHCP Snooping & DAI.....	83
1.19	Private VLANs	85
1.20	HSRP	87
1.21	VRRP	91
1.22	GLBP	95
Building Scalable Cisco Internetworks (BSCI).....		101
	Case Study Overview	101
	DBM Inc. EIGRP Diagram	102
2.1	Basic EIGRP	103
2.2	EIGRP Security	103
2.3	EIGRP Convergence Optimization	104
2.4	EIGRP Load Balancing.....	104
2.5	EIGRP Summarization	104
2.6	EIGRP Default Routing.....	105
2.7	EIGRP Stub Routing.....	105
	DBM Inc. OSPF Diagram	106
3.1	Single Area OSPF	107
3.2	Multi-Area OSPF	108
3.3	OSPF Optimization.....	109
3.4	OSPF Security.....	109
3.5	OSPF Redundancy.....	109
3.6	OSPF Path Selection.....	110
3.7	OSPF Summarization.....	110
3.8	OSPF Stub Areas	110
	DBM Inc. IS-IS Diagram	111
4.1	Level-2 IS-IS.....	112
4.2	Level-1 IS-IS.....	113
4.3	IS-IS Optimization.....	113
4.4	IS-IS Security	113
4.5	IS-IS Path Selection	114
4.6	IS-IS Summarization.....	114

DBM Inc. BGP Diagram.....	115
5.1 iBGP Peerings.....	116
5.2 EBGP Peerings.....	117
5.3 BGP NLRI Advertisements.....	117
5.4 BGP Aggregation.....	117
5.5 Outbound BGP Path Selection.....	118
5.6 Inbound BGP Path Selection.....	118
DBM Inc. Multicast Diagram.....	119
6.1 PIM.....	120
6.2 Multicast Testing.....	120
DBM Inc. IPv6 Diagram.....	121
7.1 IPv6 Addressing.....	122
7.2 IPv6 OSPFv3 Routing.....	122
BSCI Solutions.....	123
2.1 Basic EIGRP.....	123
2.2 EIGRP Security.....	127
2.3 EIGRP Convergence Optimization.....	132
2.4 EIGRP Load Balancing.....	135
2.5 EIGRP Summarization.....	137
2.6 EIGRP Default Routing.....	138
2.7 EIGRP Stub Routing.....	139
3.1 Single Area OSPF.....	142
3.2 Multi-Area OSPF.....	153
3.3 OSPF Optimization.....	166
3.4 OSPF Security.....	174
3.5 OSPF Redundancy.....	178
3.6 OSPF Path Selection.....	182
3.7 OSPF Summarization.....	185
3.8 OSPF Stub Areas.....	187
4.1 Level-2 IS-IS.....	192
4.2 Level-1 IS-IS.....	197
4.3 IS-IS Optimization.....	201
4.4 IS-IS Security.....	204
4.5 IS-IS Path Selection.....	206
4.6 IS-IS Summarization.....	209
5.1 iBGP Peerings.....	211
5.2 EBGP Peerings.....	213
5.3 BGP NLRI Advertisements.....	217
5.4 BGP Aggregation.....	219
5.5 Outbound BGP Path Selection.....	221
5.6 Inbound BGP Path Selection.....	222
6.1 PIM.....	223
6.2 Multicast Testing.....	229
7.1 IPv6 Addressing.....	230
7.2 IPv6 OSPFv3 Routing.....	233

About This Workbook

Internetwork Expert's CCNP Lab Workbook is designed to be used as a supplement to INE's CCNP Bootcamp Class-on-Demand, the ultimate all-in-one solution for engineers pursuing the Cisco Certified Network Professional.

Developed from the ground up by Brian Dennis, 5 x CCIE #2210 (Routing & Switching, ISP Dial, Security, Service Provider, Voice) and Brian McGahan, 3 x CCIE #8593 (Routing & Switching, Service Provider, Security), this Class-on-Demand series includes more than 50 hours of instructor-led videos, and uses INE's tried and true hands-on learning approach. This unique method of delivery allows you to not only learn how advanced networking technologies work in real-world design scenarios, but to also see live Cisco IOS command line and SDM GUI examples of how to configure, verify, and troubleshoot them.

Keeping in theme with the Class-on-Demand methodology, the goal of this workbook is to not only prepare you for the hands-on portions of the CCNP BCMSN, BSCI, ISCW, and ONT exams, but to also learn how and why these technologies are implemented in a real world network design.



For More Information

For more information on INE's CCNP Bootcamp Class-on-Demand, along with our other training programs, visit us on the web at <http://www.INE.com> or call toll free 877-224-8987, +1-775-826-4344 outside the US. We are also available via live chat through our website and e-mail at sales@INE.com

How To Use This Workbook

The exercises in this workbook are presented in the form of fictitious case studies in which you have been hired by Dexter Bean Manufacturing Inc. (DBM Inc.) to implement a new network design according to their business needs. Specifically, these exercises are subdivided into two portions, the actual case study questions, followed by the solutions.

The case study questions portion presents various design and implementation problems that must be solved in order to meet the client's requirements. Many of these problems are typical of what you might see in a real-world network design, and attempt to illustrate the "why" behind the chosen solutions.

The solutions portion presents the actual IOS CLI and SDM based configurations needed to solve the client's requirements. This section also includes detailed verification and troubleshooting procedures illustrated through various "show" and "debug" commands supported by the Cisco IOS. This portion attempts to illustrate how a structured approach to implementation, verification, and troubleshooting can be developed, which is vital in a real-world network design to ensure that the network is performing per its design specifications.

In order to complete these hands-on exercises, you must have access to Cisco IOS based routers and switches to perform the configurations. Access to these devices can be acquired through equipment purchased for a home or office based lab, through online rack rentals, or through virtualization software such as Dynamips/Dynagen/GNS3. The following section, *Hardware Requirements*, outlines these needs in detail.

Hardware Requirements

The hardware topology used for INE's CCNP Lab Workbook is a slightly modified version of INE's CCIE Routing & Switching Lab Workbook (IEWB-RS) Hardware Specification. This specification includes six routers with FastEthernet and Serial interfaces, four Layer 3 IOS based Catalyst switches, a Frame Relay switch, and an optional Terminal Server. Using this specification ensures that all relevant technologies and features tested on in the various CCNP exams can be illustrated live on the equipment.

Note

For the most updated version of INE's CCIE Routing & Switching Lab Workbook Hardware Specification, visit <http://www.INE.com/topology.htm>.

Physical Devices Specification

The physical platforms, their modules, and memory requirements are as follows.

Device	Platform	DRAM	Flash	Installed WICs / Modules
R1	2610XM	128	32	2 - WIC-1T
R2	2610XM	128	32	2 - WIC-1T
R3	2611XM	128	32	1 - NM-4A/S
R6	1841	256	64	2 - WIC-1T
R6	1841	256	64	2 - WIC-1T
R6	1841	256	64	N/A
SW1	3560-24TS-E	Default	Default	N/A
SW2	3560-24TS-E	Default	Default	N/A
SW3	3550-24-EMI	Default	Default	N/A
SW4	3550-24-EMI	Default	Default	N/A
Frame Relay Switch	2522	16	16	N/A
Terminal Server	2511	16	16	N/A

Physical WAN Cabling

The physical Serial cabling used is as follows. Note that the Frame Relay Switch will be preconfigured, and requires no user intervention once initially setup. Refer to the *Initial Configurations* section for more information.

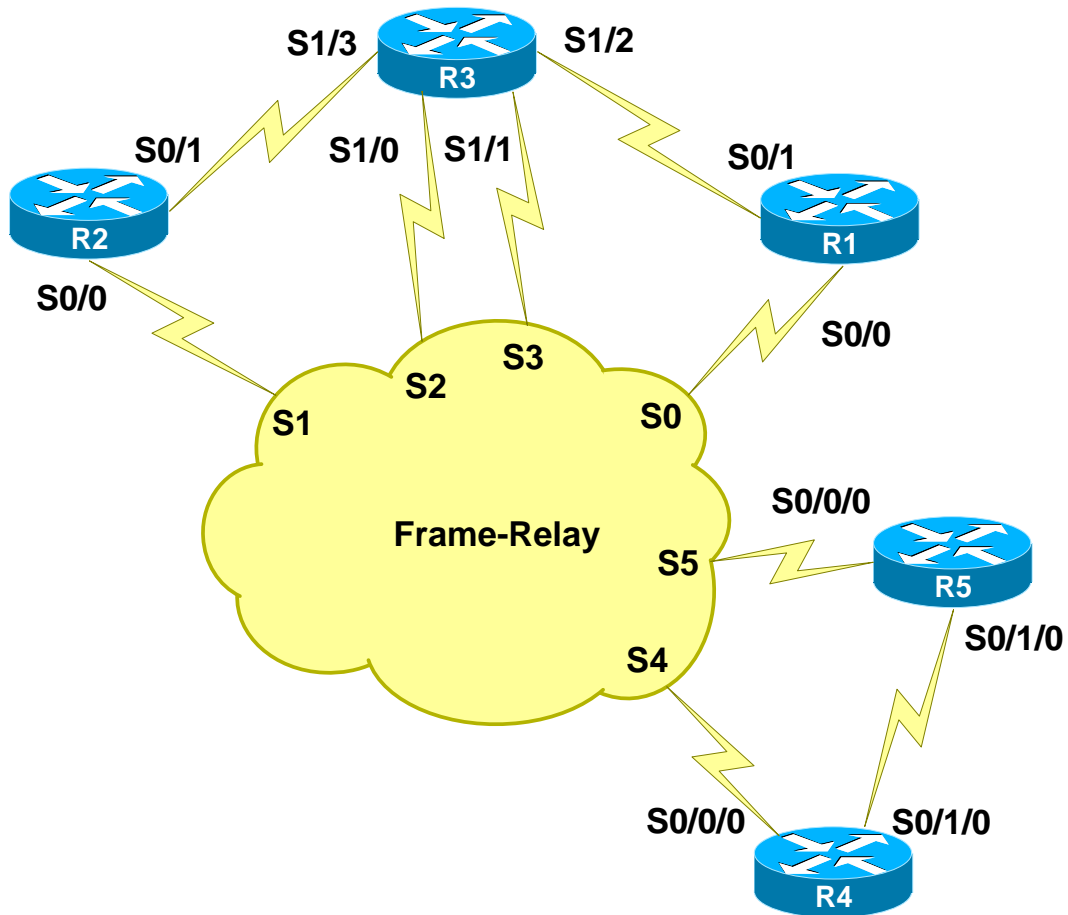

Physical LAN Cabling

The physical Ethernet cabling used is as follows. Note that the Catalyst 3550 series switches do not support the Auto MDIX feature, which means that the Category 5 (or equivalent) cables used should be wired for crossover for all inter-switch links between the 3550's.

Ethernet Connections			
Local Device	Local Interface	Remote Device	Remote Interface
R1	Fa0/0	SW1	Fa0/1
R2	Fa0/0	SW2	Fa0/2
R3	Fa0/0	SW1	Fa0/3
R3	Fa0/1	SW3	Fa0/3
R4	Fa0/0	SW2	Fa0/4
R4	Fa0/1	SW4	Fa0/4
R5	Fa0/0	SW1	Fa0/5
R5	Fa0/1	SW3	Fa0/5
R6	Fa0/0	SW2	Fa0/6
R6	Fa0/1	SW4	Fa0/6
SW1	Fa0/1	R1	Fa0/0
SW1	Fa0/3	R3	Fa0/0
SW1	Fa0/5	R5	Fa0/0
SW2	Fa0/2	R2	Fa0/0
SW2	Fa0/4	R4	Fa0/0
SW2	Fa0/6	R6	Fa0/0
SW3	Fa0/3	R3	Fa0/1
SW3	Fa0/5	R5	Fa0/1
SW4	Fa0/4	R4	Fa0/1
SW4	Fa0/6	R6	Fa0/1

Switch to Switch Connections			
Local Switch	Local Interface	Remote Switch	Remote Interface
SW1	Fa0/13	SW2	Fa0/13
SW1	Fa0/14	SW2	Fa0/14
SW1	Fa0/15	SW2	Fa0/15
SW1	Fa0/16	SW3	Fa0/13
SW1	Fa0/17	SW3	Fa0/14
SW1	Fa0/18	SW3	Fa0/15
SW1	Fa0/19	SW4	Fa0/13
SW1	Fa0/20	SW4	Fa0/14
SW1	Fa0/21	SW4	Fa0/15
Local Switch	Local Interface	Remote Switch	Remote Interface
SW2	Fa0/13	SW1	Fa0/13
SW2	Fa0/14	SW1	Fa0/14
SW2	Fa0/15	SW1	Fa0/15
SW2	Fa0/16	SW3	Fa0/16
SW2	Fa0/17	SW3	Fa0/17
SW2	Fa0/18	SW3	Fa0/18
SW2	Fa0/19	SW4	Fa0/16
SW2	Fa0/20	SW4	Fa0/17
SW2	Fa0/21	SW4	Fa0/18
Local Switch	Local Interface	Remote Switch	Remote Interface
SW3	Fa0/13	SW1	Fa0/16
SW3	Fa0/14	SW1	Fa0/17
SW3	Fa0/15	SW1	Fa0/18
SW3	Fa0/16	SW2	Fa0/16
SW3	Fa0/17	SW2	Fa0/17
SW3	Fa0/18	SW2	Fa0/18
SW3	Fa0/19	SW4	Fa0/19
SW3	Fa0/20	SW4	Fa0/20
SW3	Fa0/21	SW4	Fa0/21
Local Switch	Local Interface	Remote Switch	Remote Interface
SW4	Fa0/13	SW1	Fa0/19
SW4	Fa0/14	SW1	Fa0/20
SW4	Fa0/15	SW1	Fa0/21
SW4	Fa0/16	SW2	Fa0/19
SW4	Fa0/17	SW2	Fa0/20
SW4	Fa0/18	SW2	Fa0/21
SW4	Fa0/19	SW3	Fa0/19
SW4	Fa0/20	SW3	Fa0/20
SW4	Fa0/21	SW3	Fa0/21

Software Versions

The IOS software versions used are as follows. Note that some of these revisions may be deferred and unavailable if you attempt to download them from www.cisco.com. In that case, choose the next or closest revision that is available for download.

Device	Software Version	Software Feature Set	Filename
R1	12.4(10)A	Advanced Enterprise Services	c2600-adventerprisek9-mz.124-10a.bin
R2	12.4(10)A	Advanced Enterprise Services	c2600-adventerprisek9-mz.124-10a.bin
R3	12.4(10)A	Advanced Enterprise Services	c2600-adventerprisek9-mz.124-10a.bin
R4	12.4(24)T1	Advanced Enterprise Services	c1841-adventerprisek9-mz.124-24.T1.bin
R5	12.4(24)T1	Advanced Enterprise Services	c1841-adventerprisek9-mz.124-24.T1.bin
R6	12.4(24)T1	Advanced Enterprise Services	c1841-adventerprisek9-mz.124-24.T1.bin
SW1	12.2(44)SE	EMI	c3560-advipservicesk9-mz.122-44.SE.bin
SW2	12.2(44)SE	EMI	c3560-advipservicesk9-mz.122-44.SE.bin
SW3	12.2(25)SEC2	EMI	c3550-ipservicesk9-mz.122-25.SEC2.bin
SW4	12.2(25)SEC2	EMI	c3550-ipservicesk9-mz.122-25.SEC2.bin
Frame Relay	12.2(15)T17	IP Plus	c2500-is-l.122-15.T17.bin
Terminal Server	12.2(15)T17	IP Plus	c2500-is-l.122-15.T17.bin

Purchasing Equipment

The most convenient way to have always available access to your practice lab is to simply purchase the equipment to dedicate to your studies. If you were to buy all of the devices listed above, your topology would match ours exactly. However, this option is typically not cost effective for most candidates.

If you are purchasing your own equipment, the devices do not need to be an exact match to our specification. For example, 2800s and 3800s will support all features that 1800s do, but they are generally more expensive. What is most important however, is what software versions the platform supports.

Before choosing a platform to buy visit the Cisco IOS Feature Navigator at <http://www.cisco.com/go/fn/> to compare which features and IOS versions a particular platform supports, along with what the memory requirements in order to run it are.

For pricing on new equipment contact your local Cisco reseller. Used equipment pricing can be found on www.ebay.com. Affordable pricing for memory and cables can be found at sites such as www.monoprice.com, www.crucial.com, and www.anthonypanda.com. As usual, buyer beware whenever purchasing equipment on the used market.

Lastly, an important part of buying equipment that many people overlook is the space, power, and cooling requirements, along with the noise generated by ten or more routers sitting on your desk. Be sure to budget all of these into your overall equipment investment decision.

Online Rack Rentals

An affordable alternative to purchasing equipment that many engineers turn to is using online rack rental providers. Using rack rental providers allows you the same access to real live equipment as if you had it sitting physically in your office, but you don't need to worry about issues such as a large upfront cost, auction sites, cabling problems, memory, obtaining software, space, power, cooling, etc.

Most rack rental providers offer pricing per hour or block of hours, as well as bulk pricing per week, month, etc. Typically the only requirement to access online racks is an internet connection, and a terminal emulation software such as HyperTerminal or SecureCRT for initiating a Telnet connection.

Note that any rack rental provider that supports INE's CCIE Routing & Switching Lab Workbook (IEWB-RS) topology will be able to support the topology needed for this CCNP Lab Workbook.

Note

INE's preferred rack rental provider is <http://www.GradedLabs.com>. GradedLabs not only provides the highest value at the lowest cost, they also provide top-notch support and a suite of sophisticated tools to enhance your learning experience, such as automated configuration archiving, automated scheduling, and the ability to immediately schedule sessions already in progress at a discounted price.

More information about these services can be found at <http://www.INE.com/rackrentals.htm> and <http://www.GradedLabs.com>.

Dynamips, Dynagen, & GNS3

Another alternative to using real equipment is an IOS virtualization program known as Dynamips. Unlike IOS simulation programs, such as Cisco's Packet Tracer, Dynamips allows you to run real IOS code on your Windows, MacOS, or Linux based desktop or laptop, and have the different IOS instances interact with each other as if they were real physical routers. While simulation programs may be good for entry level training such as CCENT, they lack the full IOS feature set support that is required for advanced applications such as CCNP or CCIE preparation.

The two main disadvantages of using Dynamips are the learning curve of getting a functional and stable topology, and the physical hardware requirements of your laptop or desktop. However, with the advent of the CLI based Dynagen application, and the GUI based GNS3 application, both which are simplified launchers for Dynamips, many engineers are turning to this as an alternative to buying equipment.

There are many resources available for how to use Dynamips, Dynagen, and GNS3, all of which are outside the scope of this workbook. INE does however officially support these programs for its products, and also has multiple Class-on-Demand video tutorials on how to use them.



For More Information

For more information on using Dynamips for CCNP preparation, along with Class-on-Demand video tutorials, visit <http://www.INE.com/dynamips.htm>.

Initial Configurations

In order to streamline the configuration for some sections and devices, INE's CCNP Lab Workbook requires that the initial configuration scripts be loaded prior to starting some individual lab exercises. For example, the Frame Relay Switch configuration is static, and once loaded with the initial configuration script, requires no interaction from the candidate's perspective.

If an initial configuration is required for a section, it will be clearly outlined in that actual lab task. For the most recent copy of these configuration scripts see the CCNP Bootcamp Class-on-Demand section of Internetnetwork Expert's members site where you downloaded this workbook at <http://members.INE.com>.

Support Resources

Achieving the CCNP certification is just one continuing step in advancing your career as a network engineer. Like many other industries, the computer networking field is not only about networking with computers, it is about networking with people. Internetnetwork Expert's Online Community – <http://www.IEOC.com> – offers you the chance to interact with thousands of other engineers involved in the networking field, and specifically with Cisco certification.

IEOC allows you to create new posts and reply to other posts like a normal web forum, but you can also read and submit posts via email. For example if you email ccnp@ieoc.com your message will be sent out to all users subscribed to the CCNP email feed, plus posted on the web forum as viewable and searchable content.

An additional free resource offered by INE is our blog. The INE blog contains hundreds of articles on technical topics from A to Z, or AAA to Zone Based Firewall to be more specific. To read previous posts or submit topic requests visit <http://blog.INE.com>.

Building Cisco Multilayered Switched Networks (BCMSN)

Case Study Overview

Dexter Bean Manufacturing was founded five years ago by partners Dexter and Bean in order to provide their customers with high quality widgets and exceptional customer service at a reasonable price. Since its humble beginnings with the two partners, DBM Inc. has expanded their market share exponentially each year, and currently employs 300 workers spread between four offices.

As DBM Inc.'s business needs have far outgrown the original capacity of their part-time IT department, you have been hired along with a network architecture team in order to implement a new network infrastructure that will support their growth for the foreseeable future.

The first major infrastructure change at DBM Inc. is the migration from a flat shared layer 2 network consisting of hubs and unmanaged switches, to a hierarchical layer 2 and layer 3 switched network employing VLANs and routing for traffic separation and security.

Using the included physical wiring table, configure the layer 2 switched network per the following architecture team's requirements.

DBM Inc. Campus Diagram

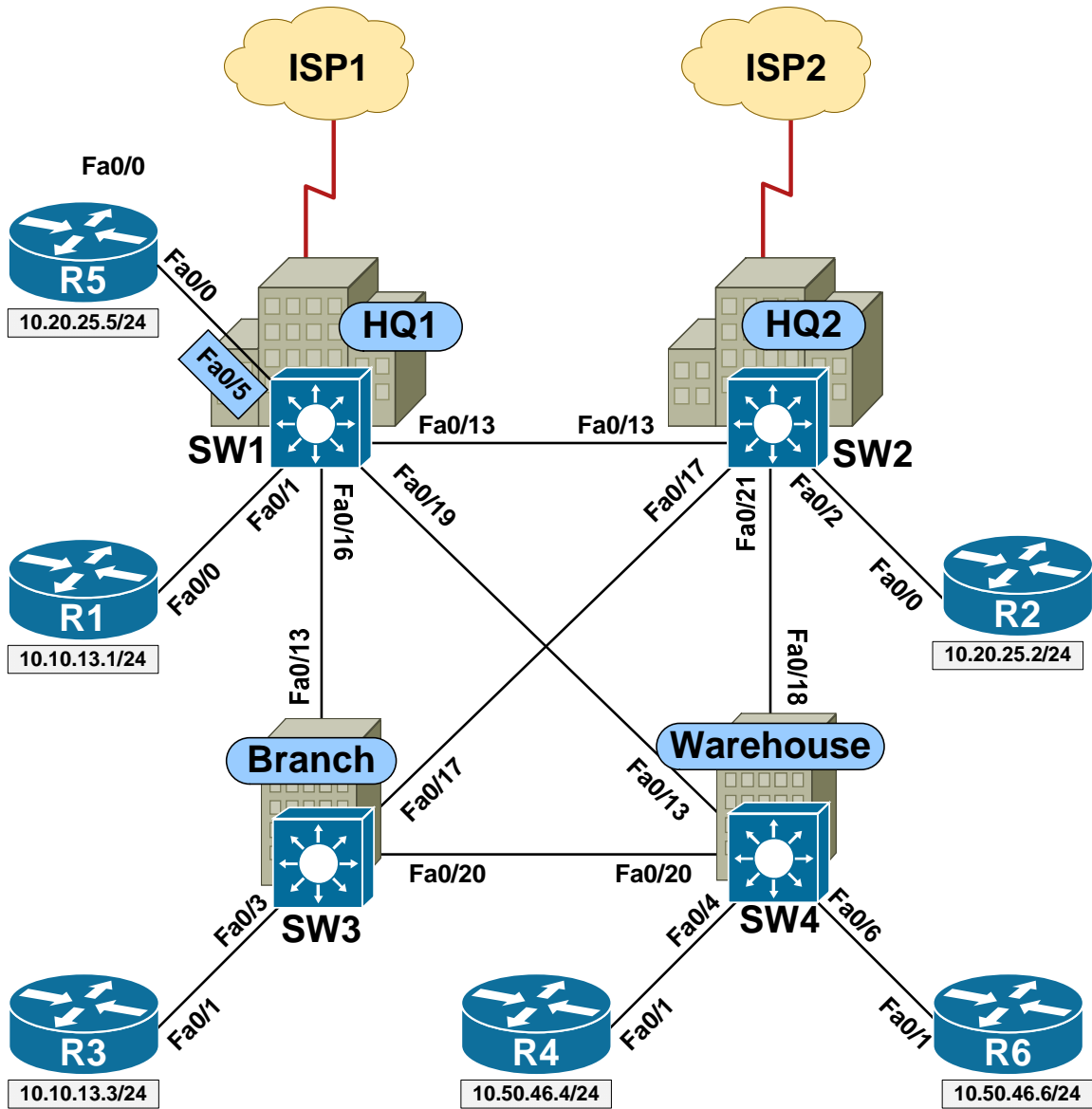

 **Note**

Prior to starting this section load the *BCMSN Basic Initial Configs* for all devices. Refer to the *DBM Inc. Campus Diagram* for device and port information.

1.1 VLANs

- The design team has mandated that traffic be logically separated in the network based on the organizational chart that was supplied to them by management. Specifically, VLANs have been mapped to different functional departments as follows:
 - SALES – VLAN 10
 - ACCOUNTING – VLAN 20
 - MANAGEMENT – VLAN 30
 - CUSTOMER_SERVICE – VLAN 40
 - WAREHOUSE – VLAN 50
 - GUEST_ACCESS – VLAN 60
- Using the VLAN database mode on SW1 and SW2, configure the VLANs as listed above, including their names.
- Using global configuration mode on SW3 and SW4, configure the VLANs as listed above, including their names.

1.2 Access Ports

- Now that VLANs have been created in order to separate traffic logically at layer 2 in the network, the design team has provided you a list of port assignments for the VLANs. Additionally, they have requested that these ports be configured in access mode to prevent any negotiation errors related to Dynamic Trunking Protocol (DTP).
- Configure the access mode and VLAN assignments per the list:

Device	Port	VLAN
SW1	Fa0/1	10
SW1	Fa0/2	60
SW1	Fa0/4	20
SW1	Fa0/5	20
SW1	Fa0/7	60
SW1	Fa0/8	10
SW2	Fa0/1	40
SW2	Fa0/2	20
SW2	Fa0/3	40
SW2	Fa0/5	30
SW2	Fa0/8	30
SW2	Fa0/9	30
SW3	Fa0/2	10
SW3	Fa0/3	10
SW3	Fa0/4	50
SW3	Fa0/9	50
SW3	Fa0/10	60
SW3	Fa0/11	60
SW4	Fa0/1	50
SW4	Fa0/2	50
SW4	Fa0/3	60
SW4	Fa0/4	50
SW4	Fa0/5	60
SW4	Fa0/6	50

1.3 ISL Trunk Ports

- The design team has informed you that since some VLANs span multiple physical switches, layer 2 trunk links are required between the switches. They have decided that multiple links will be used for redundancy, the encapsulation will be ISL, and Dynamic Trunking Protocol (DTP) will be used to negotiate the links.
- Configure the trunk links per the list you have been provided with below:

Local Device	Local Port	Local Device	Local Port	DTP Mode
SW1	Fa0/13	SW2	Fa0/13	Desirable
SW1	Fa0/16	SW3	Fa0/13	Desirable
SW1	Fa0/19	SW4	Fa0/13	Desirable
SW2	Fa0/13	SW1	Fa0/13	Desirable
SW2	Fa0/17	SW3	Fa0/17	Desirable
SW2	Fa0/21	SW4	Fa0/18	Desirable
SW3	Fa0/13	SW1	Fa0/16	Auto
SW3	Fa0/17	SW2	Fa0/17	Auto
SW3	Fa0/20	SW4	Fa0/20	Desirable
SW4	Fa0/13	SW1	Fa0/19	Auto
SW4	Fa0/18	SW2	Fa0/21	Auto
SW4	Fa0/20	SW3	Fa0/20	Auto

- Once complete, test basic IP connectivity between R1 & R3, R2 & R5, and R4 & R6 using the IP address information in the diagram.

1.4 802.1Q Trunk Ports

- After further review, the architecture team has decided to scrap the original trunking design using ISL encapsulation with DTP in favor of 802.1Q without DTP. Specifically 802.1Q trunking was chosen over ISL in order to ensure vendor interoperability for new additions to the network in the future, while DTP was chosen to be disabled to reduce layer 2 convergence time in the event of a trunk link failure.
- Modify the previously configured trunk links to use 802.1Q encapsulation as opposed to ISL, and to not use DTP.
- For added security the design team has requested that all dot1q trunk links use the native VLAN number 666, which is an unassigned VLAN.

1.5 Controlling Traffic over Trunk Ports

- The design team has informed you that after periodic network monitoring, it appears that a large amount of broadcast traffic in the WAREHOUSE VLAN has been transiting between buildings, even though devices in the WAREHOUSE VLAN are physically constrained to just one building. This has been slowing down the performance of other network applications as the links between buildings only have a limited amount of bandwidth.
- To resolve this they have requested that you modify the allowed list of the trunk links on SW4 so that traffic in the WAREHOUSE VLAN cannot be sent over its ports connecting to the other buildings.

1.6 VLAN Trunk Protocol (VTP)

- After further discussion, the architecture team has determined that with the addition of more VLANs in the future, maintaining VLAN definitions and trunk filtering on individual switches will require too much management overhead. In order to resolve this, they have decided to add VLAN Trunk Protocol (VTP) to the network design to centralize the management of VLANs.
- The VTP policy that they have defined is as follows:
 - VTP Domain – DBM_INC
 - VTP Password – WIDGETS
 - VTP Server – SW1
 - VTP Clients – SW2, SW3, & SW4
- New VLANs to be added the network and their assignments are as follows:
 - LOBBY – VLAN 100
 - SW1 Fa0/10 & Fa0/11
 - CONFERENCE_ROOM – VLAN 200
 - SW2 Fa0/10 & Fa0/11
 - CAFETERIA – VLAN 300
 - SW4 Fa0/10 & Fa0/11
- Implement the new VTP policy and VLAN assignments per their request.

1.7 VTP Pruning

- In addition to centralized management of VLAN names and numbers, the design team has informed you they chose to implement VTP in order to automate trunking allowed list filtering through the VTP Pruning feature.
- They have requested that you remove the previously implemented static trunk allowed list filtering on SW4, and replace it with dynamic VTP Pruning throughout the entire layer 2 switched network.

1.8 VTP Transparent Mode

- After the layer 2 network appeared be running smoothly, your team received numerous emergency support tickets that the network was completely down and unusable. After further investigation, you discovered that an employee in the warehouse took an extra switch out of the supply closet, and plugged it into his office to add extra ports for his laptop he brought from home. Unfortunately this switch had been preconfigured in the test lab with the correct VTP domain name and password, but did not have the correct VLAN database, and had a higher VTP configuration revision number than the rest of the network. This meant that once connected, the switch overwrote the entire VTP domain with the wrong list of VLANs, and the network went down.
- After numerous debates on how to resolve this issue, the design team has decided to change all switches to VTP Transparent mode. Although this will sacrifice some management flexibility, it will increase security and prevent a misconfigured switch from overwriting the network again in the future.
- Configure the network per their request to implement VTP Transparent mode on all switches.

1.9 Spanning-Tree Protocol

- Now that the network is functioning in a stable manner, the design team has been monitoring traffic patterns in order to optimize layer 2 traffic flows. Specifically they have found a recent increase in traffic flows through VLANs 10 and 20, with the majority of VLAN 10 traffic transiting through the HQ1 office, and the majority of the VLAN 20 traffic transiting through the HQ2 office. In order to alleviate congestion, the design team has tasked you with the following.
- Add an additional 802.1Q trunk link between SW1 and SW2 using port Fa0/14 on both switches.
- Modify the Spanning-Tree for VLAN 10 as follows:
 - SW1 should be the Root Bridge
 - SW2 should be the backup Root Bridge
 - SW2 should select port Fa0/14 as its Root Port instead of Fa0/13
- Modify the Spanning-Tree for VLAN 20 as follows:
 - SW2 should be the Root Bridge
 - SW1 should be the backup Root Bridge
 - SW1 should select port Fa0/14 as its Root Port instead of Fa0/13
- Verify correct layer 2 traffic forwarding by examining the CAM table of these switches.

1.10 Rapid PVST+

- During a scheduled maintenance window the design team has been testing layer 2 network reconvergence times. Consistent results have shown that under certain circumstances a single link failure can cause the network to be down in excess of 30 seconds while STP detects the failure and converges around it. As the next major stage of the network design includes a new VoIP implementation to replace the legacy PBX system, these figures are unacceptable. To resolve this the design team has requested that you change the STP mode of the layer 2 switches from PVST+ to Rapid PVST+, and to designate all access ports as edge ports.
- Implement this change, then test the new convergence time by sending ICMP Echos between R2 and R5, and disabling the port Fa0/14 between SW1 and SW2.

1.11 Multiple Spanning-Tree Protocol

- Shortly after the changeover to Rapid PVST+, the design team was informed that some new switches which were purchased for DBM Inc. are from a different equipment vendor, and do not support Rapid PVST+. Fortunately they do support both 802.1w based Rapid Spanning-Tree, and 802.1s based Multiple Spanning-Tree. Based on this the design team has tasked you with migrating the network from Rapid PVST+ to MST.
- To accomplish this implement MST with the following parameters:
 - MST region name DBM_INC
 - MST region revision number 10
 - Instance 1 should map to VLANs 10, 30, and 50
 - Instance 2 should map to VLANs 20, 40, and 60
 - Instance 3 should map to VLANs 100, 200, and 300
 - SW1 should be the Root Bridge for instance 1
 - SW2 should be the backup Root Bridge for instance 1
 - SW2 should be the Root Bridge for instance 2
 - SW1 should be the backup Root Bridge for instance 2
 - SW2 should elect port Fa0/14 as its root port for instance 1
 - SW1 should elect port Fa0/14 as its root port for instance 2
- Implement this change, then test the new convergence time by sending ICMP Echos between R2 and R5, and disabling the port Fa0/14 between SW1 and SW2.

1.12 Spanning-Tree Protocol Features

- Recently you received a memo from the network design team regarding further STP optimization and security. Specifically they have requested that you implement the following features in the layer 2 network:
 - All ports connected to the LOBBY should run BPDUGuard to prevent against STP attacks.
 - All ports connected to the CONFERENCE ROOM should run RootGuard to prevent suboptimal forwarding due to bridge priority misconfigurations.
 - All ports connected to the CAFETERIA should run BPDUFILTER to not send or receive STP packets.
 - All trunk ports should run LoopGuard and UDLD to prevent against unidirectional links

1.13 EtherChannel

- In order to increase bandwidth between offices, the design team has had additional physical circuits provisioned. However, since STP does not allow multiple redundant links in the network, they have tasked you with bonding these new links together with the previous circuits to form EtherChannels. The design team has provided you with the following list of ports to form bonded links and their configurations.
 - Port-Channel12
 - SW1 ports Fa0/13 & Fa0/14 to SW2 ports Fa0/13 & Fa0/14
 - Use no negotiation for this link
 - Port-Channel13
 - SW1 ports Fa0/16 & Fa0/17 to SW3 ports Fa0/13 & Fa0/14
 - Use PAgP negotiation for this link
 - Port-Channel24
 - SW2 ports Fa0/19 & Fa0/21 to SW4 ports Fa0/16 & Fa0/18
 - Use LACP negotiation for this link
 - All EtherChannels should be 802.1Q trunk links.

1.14 Inter-VLAN Routing

- Now that the layer 2 network is built properly, the design team has requested that you configure the network for layer 3 routing in order to allow hosts in different VLANs to communicate with each other. However, there has been some debate internally between the design team members as to what is the most efficient way to accomplish this. Therefore, they have requested that you implement both Router-on-a-Stick and Switched Virtual Interfaces for Inter-VLAN routing.
- Configure Router-on-a-Stick as follows:
 - Remove the configuration on R1's Fa0/0 interface
 - Configure SW1's link to R1's Fa0/0 as an 802.1q trunk port
 - Filter all VLANs on this trunk with the exception of 10, 20, and 30
 - Configure R1 to encapsulate these following VLANs with the below IP addresses:
 - VLAN 10 – 10.10.13.1/24
 - VLAN 20 – 10.20.25.1/24
 - VLAN 30 – 10.30.30.1/24
 - Configure R2, R3, and R5 with default static routes pointing to the appropriate IP address on R1
- Configure Switched Virtual Interfaces as follows:
 - Configure SW1 to encapsulate the following VLANs with the below IP addresses:
 - VLAN 30 – 10.30.30.7/24
 - VLAN 40 – 10.40.40.7/24
 - VLAN 50 – 10.50.46.7/24
 - VLAN 60 – 10.60.60.7/24
 - VLAN 100 – 10.100.100.7/24
 - VLAN 200 – 10.200.200.7/24
 - VLAN 300 – 10.1.44.7/24
 - Configure R4 and R6 with default static routes pointing to the appropriate IP address on SW1
- Enable RIPv2 on all interfaces of R1 and SW1.
- Once complete all routers should have IP reachability to each other.

One of the network design team members recently attended an IT Security seminar, and has returned with various best practices security recommendations. These recommendations include the implementation of the Port Security, 802.1X Authentication, VLAN Access Lists, Private VLANs, DHCP Snooping, and Dynamic ARP Inspection features. Configure the network per the new following requirements in order to secure the network at layer 2.

1.15 Port Security

- The first portion of the new security recommendations involves filtering based on layer 2 MAC addresses. The design team has asked you to configure Port Security for MAC address filtering per these requirements:
 - Ports connected to the CONFERENCE_ROOM VLAN on SW2 should not allow more than 4 hosts per port. Traffic from more than 4 hosts per port should be dropped, but not logged.
 - Ports in the CAFETERIA VLAN connect to computer kiosks. The kiosk on port Fa0/10 of SW4 has the MAC address 00-45-CA-0C-E8-01. The kiosk on port Fa0/11 of SW4 has the MAC address 00-45-CA-0C-E8-02. If someone unplugs a kiosk and attempts to connect another device to the port, the port should be disabled for two minutes and a log message should be generated.

1.16 802.1X Authentication

- SW1's ports Fa0/10 and Fa0/11 in the LOBBY VLAN are only for internal corporate use, and not designed for guest access. To ensure that they are only used for legitimate access, the design team has requested that 802.1X authentication be used to authorize access for these ports using an internal RADIUS server.
- To accomplish this configure the ports with 802.1X authentication per the following requirements:
 - The RADIUS server's address is 10.10.13.100 and uses an encryption key of DBM_RADIUS
 - Hosts who successfully authenticate should be allowed access to the network
 - Force the hosts to re-authenticate every five minutes

1.17 VLAN Access Lists

- The design team is concerned about offering unfiltered network access to users in the GUEST_ACCESS VLAN. To resolve this they have mandated that hosts connected to these ports should only be allowed to use port 80 for HTTP and 443 for SSL.
- Use VLAN Access List filtering in order to complete their request.

1.18 DHCP Snooping & DAI

- The design team has expressed concern about potential layer 2 Man-in-the-Middle attacks being perpetrated against the WAREHOUSE VLAN in order to capture customers' financial information. To prevent this they have requested that you configure DHCP Snooping and Dynamic ARP Inspection per the following requirements:
 - Enable DHCP Snooping and DAI for VLAN 50 on SW4
 - The DHCP server for VLAN 50 is located on SW4's port Fa0/1
 - Allow for the static IP address assignments of R4 and R6

1.19 Private VLANs

- Three new public servers are scheduled to be installed at the HQ1 office connected to SW1. These servers are the public email server connected to SW1 port Fa0/6, and two mirrored public web servers connected to SW1 ports Fa0/9 and Fa0/12. The default gateway servicing these devices is on SW1's port Fa0/3. Since all of these servers have public addresses, they are on the same subnet, but the design team has requested that layer 2 filtering be configured between them using Private VLANs. Implement their filtering request per the following specification:
 - Create the primary VLAN 1000 named DMZ
 - Create a secondary VLAN 2000 named EMAIL
 - Create a secondary VLAN 3000 named WWW
 - The email server on port Fa0/6 should be in VLAN 2000, and should only be able to communicate with the default gateway on port Fa0/3.
 - The web server mirrors on ports Fa0/9 and Fa0/12 should be in VLAN 3000, and should be able to communicate with each other and the default gateway on port Fa0/3.

DBM Inc. Gateway Redundancy Diagram

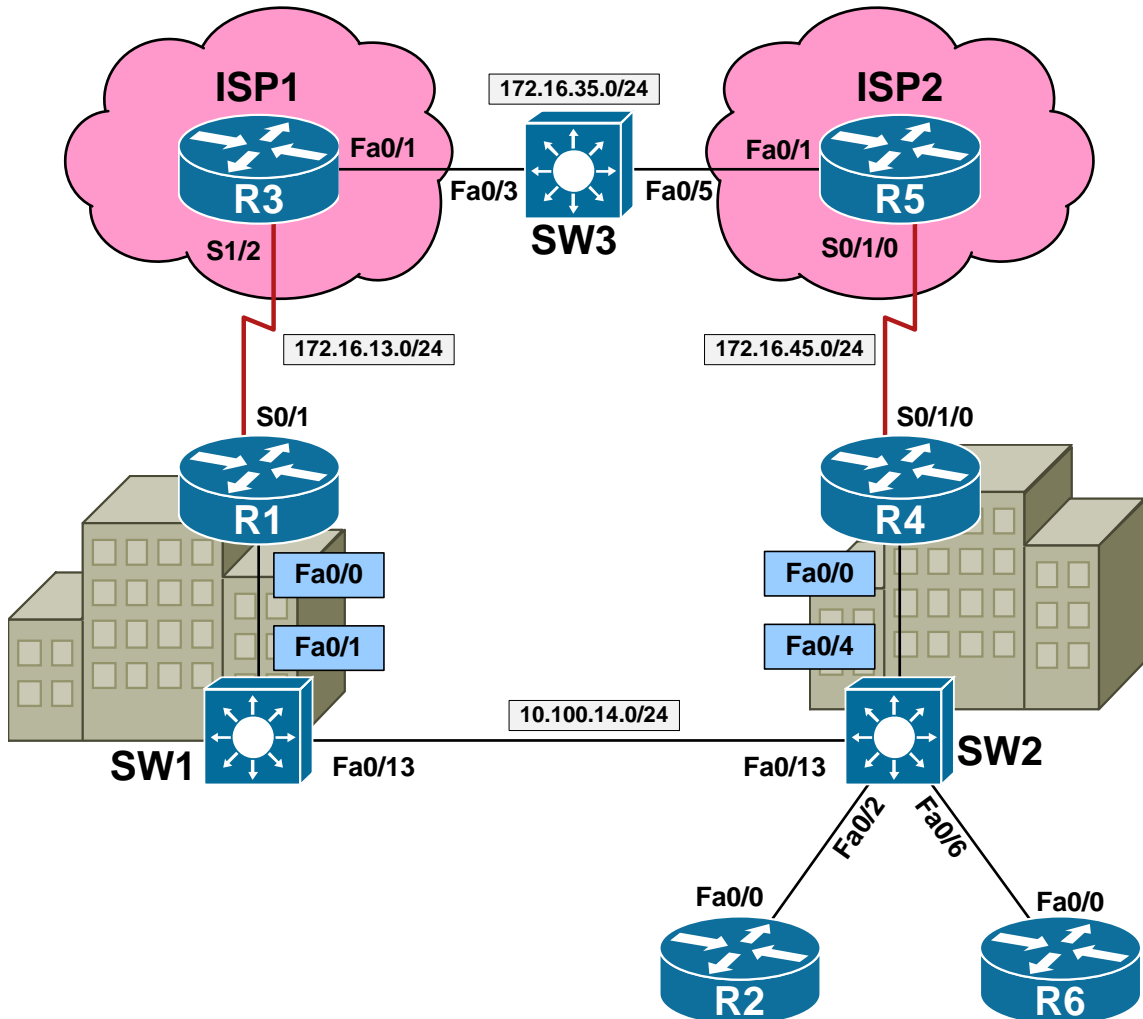

 **Note**

Prior to starting this section erase all previous configuration and load the *BCMSN Gateway Redundancy Initial Configs* for all devices. Refer to the *DBM Inc. Gateway Redundancy Diagram* for device and port information.

Internet Access from DBM Inc.'s campus network is via redundant point-to-point T1 links at the HQ1 and HQ2 sites. Edge router R1 at HQ1 connects to ISP1 via the link to R3, while edge router R4 at HQ2 connects to ISP2 via the link to R5. In order to allow for fast and transparent convergence in the event that a link or router failure occurs, the design team has requested a gateway redundancy protocol to be configured on the inside subnet that connects R1 and R4 across the layer 2 network. Configure gateway redundancy per the below requirements in order to accomplish this.

1.20 HSRP

- The design team has mandated that the primary link to the Internet should be via R1's link to ISP1, and that HSRP be used for redundancy for this connection. Configure HSRP on the inside interfaces of R1 and R4 per the following specification:
 - Use the virtual gateway address 10.100.14.254/24
 - R1 should be the primary gateway
 - If R1 is unreachable, or its link to ISP1 goes down, R4 should take over as the primary gateway
 - If R1 goes down and then comes back up at a later time it should resume its role as the primary gateway after being stable for 30 seconds
 - Authenticate the HSRP communication between R1 and R4 using the MD5 based password DBM_HSRP
 - For fast convergence HSRP keepalives should be sent every 333ms, and a neighbor should be declared down if a keepalive isn't heard within one second
- To test this configuration ping from R2 and R6 to the Internet addresses 3.3.3.3/32 and 5.5.5.5/32, and verify that reconvergence occurs if R1 is unreachable or its link to R3 is down.

1.21 VRRP

- After some debate the design team has decided that they would prefer to use open standards based protocols whenever possible, so they have requested that you modify your design to use the open standards based VRRP as opposed to the Cisco proprietary HSRP.
- Implement this change while maintaining the original design specification requirements.

1.22 GLBP

- Upper management has been complaining to the design team that Internet access is slow, even though they're paying hefty fees for multiple connections to different providers. The design team explained to them that with the current configuration, only one Internet link can be used at a time. As management has been insistent that they should be fully using what they're paying for, the design team has requested that you modify your implementation to use GLBP as opposed to HSRP or VRRP.
- Specifically they have requested the following changes to be implemented with GLBP:
 - R1 should be the preferred gateway over R4 in a ratio of 2:1
 - If R1's link to ISP1 is down, it should not be used for forwarding
 - Likewise if R4's link to ISP2 is down, it should not be used for forwarding
 - Preemption should occur immediately if the other neighbor is down or their tracked link is down
 - All other original design specifications should remain the same

BCMSN Solutions

1.1 VLANs

Configuration

```
SW1#vlan database
% Warning: It is recommended to configure VLAN from config mode,
as VLAN database mode is being deprecated. Please consult user
documentation for configuring VTP/VLAN in config mode.

SW1(vlan)#vlan 10 name SALES
VLAN 10 added:
  Name: SALES
SW1(vlan)#vlan 20 name ACCOUNTING
VLAN 20 added:
  Name: ACCOUNTING
SW1(vlan)#vlan 30 name MANAGEMENT
VLAN 30 added:
  Name: MANAGEMENT
SW1(vlan)#vlan 40 name CUSTOMER_SERVICE
VLAN 40 added:
  Name: CUSTOMER_SERVICE
SW1(vlan)#vlan 50 name WAREHOUSE
VLAN 50 added:
  Name: WAREHOUSE
SW1(vlan)#vlan 60 name GUEST_ACCESS
VLAN 60 added:
  Name: GUEST_ACCESS
SW1(vlan)#exit
APPLY completed.
Exiting....
SW1#
```

```
SW2#vlan database
% Warning: It is recommended to configure VLAN from config mode,
as VLAN database mode is being deprecated. Please consult user
documentation for configuring VTP/VLAN in config mode.

SW2(vlan)#vlan 10 name SALES
VLAN 10 added:
  Name: SALES
SW2(vlan)#vlan 20 name ACCOUNTING
VLAN 20 added:
  Name: ACCOUNTING
SW2(vlan)#vlan 30 name MANAGEMENT
VLAN 30 added:
  Name: MANAGEMENT
SW2(vlan)#vlan 40 name CUSTOMER_SERVICE
VLAN 40 added:
  Name: CUSTOMER_SERVICE
SW2(vlan)#vlan 50 name WAREHOUSE
VLAN 50 added:
  Name: WAREHOUSE
```

```
SW2(vlan)#vlan 60 name GUEST_ACCESS
VLAN 60 added:
  Name: GUEST_ACCESS
SW2(vlan)#exit
APPLY completed.
Exiting....
SW2#
```

```
SW3#config t
Enter configuration commands, one per line.  End with CNTL/Z.
SW3(config)#vlan 10
SW3(config-vlan)#name SALES
SW3(config-vlan)#vlan 20
SW3(config-vlan)#name ACCOUNTING
SW3(config-vlan)#vlan 30
SW3(config-vlan)#name MANAGEMENT
SW3(config-vlan)#vlan 40
SW3(config-vlan)#name CUSTOMER_SERVICE
SW3(config-vlan)#vlan 50
SW3(config-vlan)#name WAREHOUSE
SW3(config-vlan)#vlan 60
SW3(config-vlan)#name GUEST_ACCESS
SW3(config-vlan)#end
SW3#
```

```
SW4#config t
Enter configuration commands, one per line.  End with CNTL/Z.
SW4(config)#vlan 10
SW4(config-vlan)#name SALES
SW4(config-vlan)#vlan 20
SW4(config-vlan)#name ACCOUNTING
SW4(config-vlan)#vlan 30
SW4(config-vlan)#name MANAGEMENT
SW4(config-vlan)#vlan 40
SW4(config-vlan)#name CUSTOMER_SERVICE
SW4(config-vlan)#vlan 50
SW4(config-vlan)#name WAREHOUSE
SW4(config-vlan)#vlan 60
SW4(config-vlan)#name GUEST_ACCESS
SW4(config-vlan)#end
SW4#
```

1.2 Access Ports

Configuration

```
SW1#
interface FastEthernet0/1
  switchport mode access
  switchport access vlan 10
!
interface FastEthernet0/2
  switchport mode access
  switchport access vlan 60
!
interface FastEthernet0/4
  switchport mode access
  switchport access vlan 20
!
interface FastEthernet0/5
  switchport mode access
  switchport access vlan 20
!
interface FastEthernet0/7
  switchport mode access
  switchport access vlan 60
!
interface FastEthernet0/8
  switchport mode access
  switchport access vlan 10

SW2#
interface FastEthernet0/1
  switchport mode access
  switchport access vlan 40
!
interface FastEthernet0/2
  switchport mode access
  switchport access vlan 20
!
interface FastEthernet0/3
  switchport mode access
  switchport access vlan 40
!
interface FastEthernet0/5
  switchport mode access
  switchport access vlan 30
!
interface FastEthernet0/8
  switchport mode access
  switchport access vlan 30
!
interface FastEthernet0/9
  switchport mode access
  switchport access vlan 30
```

```
SW3#
interface FastEthernet0/2
  switchport mode access
  switchport access vlan 10
!
interface FastEthernet0/3
  switchport mode access
  switchport access vlan 10
!
interface FastEthernet0/4
  switchport mode access
  switchport access vlan 50
!
interface FastEthernet0/9
  switchport mode access
  switchport access vlan 50
!
interface FastEthernet0/10
  switchport mode access
  switchport access vlan 60
!
interface FastEthernet0/11
  switchport mode access
  switchport access vlan 60
```

```
SW4#
interface FastEthernet0/1
  switchport mode access
  switchport access vlan 50
!
interface FastEthernet0/2
  switchport mode access
  switchport access vlan 50
!
interface FastEthernet0/3
  switchport mode access
  switchport access vlan 60
!
interface FastEthernet0/4
  switchport mode access
  switchport access vlan 50
!
interface FastEthernet0/5
  switchport mode access
  switchport access vlan 60
!
interface FastEthernet0/6
  switchport mode access
  switchport access vlan 50
```

Verification

SW1#show vlan brief

VLAN	Name	Status	Ports
1	default	active	Fa0/3, Fa0/6, Fa0/9, Fa0/10 Fa0/11, Fa0/12, Fa0/13, Fa0/14 Fa0/15, Fa0/22, Fa0/23, Fa0/24 Gi0/1, Gi0/2
10	SALES	active	Fa0/1, Fa0/8
20	ACCOUNTING	active	Fa0/4, Fa0/5
30	MANAGEMENT	active	
40	CUSTOMER_SERVICE	active	
50	WAREHOUSE	active	
60	GUEST_ACCESS	active	Fa0/2, Fa0/7
1002	fddi-default	act/unsup	
1003	token-ring-default	act/unsup	
1004	fddinet-default	act/unsup	
1005	trnet-default	act/unsup	

SW2#show vlan brief

VLAN	Name	Status	Ports
1	default	active	Fa0/4, Fa0/6, Fa0/7, Fa0/10 Fa0/11, Fa0/12, Fa0/13, Fa0/14 Fa0/15, Fa0/22, Fa0/23, Fa0/24 Gi0/1, Gi0/2
10	SALES	active	
20	ACCOUNTING	active	Fa0/2
30	MANAGEMENT	active	Fa0/5, Fa0/8, Fa0/9
40	CUSTOMER_SERVICE	active	Fa0/1, Fa0/3
50	WAREHOUSE	active	
60	GUEST_ACCESS	active	
1002	fddi-default	act/unsup	
1003	token-ring-default	act/unsup	
1004	fddinet-default	act/unsup	
1005	trnet-default	act/unsup	

SW3#show vlan brief

VLAN Name	Status	Ports
1 default	active	Fa0/1, Fa0/5, Fa0/6, Fa0/7 Fa0/8, Fa0/12, Fa0/22, Fa0/23 Fa0/24, Gi0/1, Gi0/2
10 SALES	active	Fa0/2, Fa0/3
20 ACCOUNTING	active	
30 MANAGEMENT	active	
40 CUSTOMER_SERVICE	active	
50 WAREHOUSE	active	Fa0/4, Fa0/9
60 GUEST_ACCESS	active	Fa0/10, Fa0/11
1002 fddi-default	act/unsup	
1003 token-ring-default	act/unsup	
1004 fddinet-default	act/unsup	
1005 trnet-default	act/unsup	

SW4#show vlan brief

VLAN Name	Status	Ports
1 default	active	Fa0/6, Fa0/7, Fa0/8, Fa0/9 Fa0/10, Fa0/11, Fa0/12, Fa0/22 Fa0/23, Fa0/24, Gi0/1, Gi0/2
10 SALES	active	
20 ACCOUNTING	active	
30 MANAGEMENT	active	
40 CUSTOMER_SERVICE	active	
50 WAREHOUSE	active	Fa0/1, Fa0/2, Fa0/4
60 GUEST_ACCESS	active	Fa0/3, Fa0/5
1002 fddi-default	act/unsup	
1003 token-ring-default	act/unsup	
1004 fddinet-default	act/unsup	
1005 trnet-default	act/unsup	

1.3 ISL Trunk Ports

Configuration

```
SW1#
interface FastEthernet0/13
  switchport trunk encapsulation isl
  switchport mode dynamic desirable
  no shutdown
!
interface FastEthernet0/16
  switchport trunk encapsulation isl
  switchport mode dynamic desirable
  no shutdown
!
interface FastEthernet0/19
  switchport trunk encapsulation isl
  switchport mode dynamic desirable
  no shutdown
```

```
SW2#
interface FastEthernet0/13
  switchport trunk encapsulation isl
  switchport mode dynamic desirable
  no shutdown
!
interface FastEthernet0/17
  switchport trunk encapsulation isl
  switchport mode dynamic desirable
  no shutdown
!
interface FastEthernet0/21
  switchport trunk encapsulation isl
  switchport mode dynamic desirable
  no shutdown
```

```
SW3#
interface FastEthernet0/13
  switchport trunk encapsulation isl
  switchport mode dynamic auto
  no shutdown
!
interface FastEthernet0/17
  switchport trunk encapsulation isl
  switchport mode dynamic auto
  no shutdown
!
interface FastEthernet0/20
  switchport trunk encapsulation isl
  switchport mode dynamic desirable
  no shutdown
```

```
SW4#  
interface FastEthernet0/13  
  switchport trunk encapsulation isl  
  switchport mode dynamic auto  
  no shutdown  
!  
interface FastEthernet0/18  
  switchport trunk encapsulation isl  
  switchport mode dynamic auto  
  no shutdown  
!  
interface FastEthernet0/20  
  switchport trunk encapsulation isl  
  switchport mode dynamic auto  
  no shutdown
```

Verification

SW1#show interface trunk

Port	Mode	Encapsulation	Status	Native vlan
Fa0/13	desirable	isl	trunking	1
Fa0/16	desirable	isl	trunking	1
Fa0/19	desirable	isl	trunking	1

Port	Vlans allowed on trunk
Fa0/13	1-4094
Fa0/16	1-4094
Fa0/19	1-4094

Port	Vlans allowed and active in management domain
Fa0/13	1,10,20,30,40,50,60
Fa0/16	1,10,20,30,40,50,60
Fa0/19	1,10,20,30,40,50,60

Port	Vlans in spanning tree forwarding state and not pruned
Fa0/13	none
Fa0/16	1,10,20,30,40,50,60
Fa0/19	none

SW2#show interface trunk

Port	Mode	Encapsulation	Status	Native vlan
Fa0/13	desirable	isl	trunking	1
Fa0/17	desirable	isl	trunking	1
Fa0/21	desirable	isl	trunking	1

Port	Vlans allowed on trunk
Fa0/13	1-4094
Fa0/17	1-4094
Fa0/21	1-4094

Port	Vlans allowed and active in management domain
Fa0/13	1,10,20,30,40,50,60
Fa0/17	1,10,20,30,40,50,60
Fa0/21	1,10,20,30,40,50,60

Port	Vlans in spanning tree forwarding state and not pruned
Fa0/13	1,10,20,30,40,50,60
Fa0/17	1,10,20,30,40,50,60
Fa0/21	none

SW3#show interface trunk

Port	Mode	Encapsulation	Status	Native vlan
Fa0/13	auto	isl	trunking	1
Fa0/17	auto	isl	trunking	1
Fa0/20	desirable	isl	trunking	1

Port Vlans allowed on trunk

Fa0/13	1-4094
Fa0/17	1-4094
Fa0/20	1-4094

Port Vlans allowed and active in management domain

Fa0/13	1,10,20,30,40,50,60
Fa0/17	1,10,20,30,40,50,60
Fa0/20	1,10,20,30,40,50,60

Port Vlans in spanning tree forwarding state and not pruned

Fa0/13	1,10,20,30,40,50,60
Fa0/17	1,10,20,30,40,50,60
Fa0/20	1,10,20,30,40,50,60

SW4#show interface trunk

Port	Mode	Encapsulation	Status	Native vlan
Fa0/13	auto	isl	trunking	1
Fa0/18	auto	isl	trunking	1
Fa0/20	auto	isl	trunking	1

Port Vlans allowed on trunk

Fa0/13	1-4094
Fa0/18	1-4094
Fa0/20	1-4094

Port Vlans allowed and active in management domain

Fa0/13	1,10,20,30,40,50,60
Fa0/18	1,10,20,30,40,50,60
Fa0/20	1,10,20,30,40,50,60

Port Vlans in spanning tree forwarding state and not pruned

Fa0/13	1,10,20,30,40,50,60
Fa0/18	1,10,20,30,40,50,60
Fa0/20	1,10,20,30,40,50,60

R1#ping 10.10.13.1

Type escape sequence to abort.
Sending 5, 100-byte ICMP Echos to 10.10.13.1, timeout is 2 seconds:
!!!!
Success rate is 100 percent (5/5), round-trip min/avg/max = 1/2/4 ms

R2#ping 10.20.25.5

Type escape sequence to abort.
Sending 5, 100-byte ICMP Echos to 10.20.25.5, timeout is 2 seconds:
!!!!
Success rate is 100 percent (5/5), round-trip min/avg/max = 1/1/4 ms

R4#ping 10.50.46.6

Type escape sequence to abort.
Sending 5, 100-byte ICMP Echos to 10.50.46.6, timeout is 2 seconds:
!!!!
Success rate is 100 percent (5/5), round-trip min/avg/max = 1/1/4 ms

1.4 802.1Q Trunk Ports

Configuration

```
SW1#
interface FastEthernet0/13
  switchport trunk encapsulation dot1q
  switchport mode trunk
  switchport trunk native vlan 666
  no shutdown
!
interface FastEthernet0/16
  switchport trunk encapsulation dot1q
  switchport mode trunk
  switchport trunk native vlan 666
  no shutdown
!
interface FastEthernet0/19
  switchport trunk encapsulation dot1q
  switchport mode trunk
  switchport trunk native vlan 666
  no shutdown

SW2#
interface FastEthernet0/13
  switchport trunk encapsulation dot1q
  switchport mode trunk
  switchport trunk native vlan 666
  no shutdown
!
interface FastEthernet0/17
  switchport trunk encapsulation dot1q
  switchport mode trunk
  switchport trunk native vlan 666
  no shutdown
!
interface FastEthernet0/21
  switchport trunk encapsulation dot1q
  switchport mode trunk
  switchport trunk native vlan 666
  no shutdown
```

```
SW3#
interface FastEthernet0/13
  switchport trunk encapsulation dot1q
  switchport mode trunk
  switchport trunk native vlan 666
  no shutdown
!
interface FastEthernet0/17
  switchport trunk encapsulation dot1q
  switchport mode trunk
  switchport trunk native vlan 666
  no shutdown
!
interface FastEthernet0/20
  switchport trunk encapsulation dot1q
  switchport mode trunk
  switchport trunk native vlan 666
  no shutdown
```

```
SW4#
interface FastEthernet0/13
  switchport trunk encapsulation dot1q
  switchport mode trunk
  switchport trunk native vlan 666
  no shutdown
!
interface FastEthernet0/18
  switchport trunk encapsulation dot1q
  switchport mode trunk
  switchport trunk native vlan 666
  no shutdown
!
interface FastEthernet0/20
  switchport trunk encapsulation dot1q
  switchport mode trunk
  switchport trunk native vlan 666
  no shutdown
```

Verification

SW1#show interface trunk

Port	Mode	Encapsulation	Status	Native vlan
Fa0/13	on	802.1q	trunking	666
Fa0/16	on	802.1q	trunking	666
Fa0/19	on	802.1q	trunking	666

Port	Vlans allowed on trunk
Fa0/13	1-4094
Fa0/16	1-4094
Fa0/19	1-4094

Port	Vlans allowed and active in management domain
Fa0/13	1,10,20,30,40,50,60
Fa0/16	1,10,20,30,40,50,60
Fa0/19	1,10,20,30,40,50,60

Port	Vlans in spanning tree forwarding state and not pruned
Fa0/13	none
Fa0/16	1,10,20,30,40,50,60
Fa0/19	none

SW2#show interface trunk

Port	Mode	Encapsulation	Status	Native vlan
Fa0/13	on	802.1q	trunking	666
Fa0/17	on	802.1q	trunking	666
Fa0/21	on	802.1q	trunking	666

Port	Vlans allowed on trunk
Fa0/13	1-4094
Fa0/17	1-4094
Fa0/21	1-4094

Port	Vlans allowed and active in management domain
Fa0/13	1,10,20,30,40,50,60
Fa0/17	1,10,20,30,40,50,60
Fa0/21	1,10,20,30,40,50,60

Port	Vlans in spanning tree forwarding state and not pruned
Fa0/13	1,10,20,30,40,50,60
Fa0/17	1,10,20,30,40,50,60
Fa0/21	none

SW3#show interface trunk

Port	Mode	Encapsulation	Status	Native vlan
Fa0/13	on	802.1q	trunking	666
Fa0/17	on	802.1q	trunking	666
Fa0/20	on	802.1q	trunking	666

Port	Vlans allowed on trunk
Fa0/13	1-4094
Fa0/17	1-4094
Fa0/20	1-4094

Port	Vlans allowed and active in management domain
Fa0/13	1,10,20,30,40,50,60
Fa0/17	1,10,20,30,40,50,60
Fa0/20	1,10,20,30,40,50,60

Port	Vlans in spanning tree forwarding state and not pruned
Fa0/13	1,10,20,30,40,50,60
Fa0/17	1,10,20,30,40,50,60
Fa0/20	1,10,20,30,40,50,60

SW4#show interface trunk

Port	Mode	Encapsulation	Status	Native vlan
Fa0/13	on	802.1q	trunking	666
Fa0/18	on	802.1q	trunking	666
Fa0/20	on	802.1q	trunking	666

Port	Vlans allowed on trunk
Fa0/13	1-4094
Fa0/18	1-4094
Fa0/20	1-4094

Port	Vlans allowed and active in management domain
Fa0/13	1,10,20,30,40,50,60
Fa0/18	1,10,20,30,40,50,60
Fa0/20	1,10,20,30,40,50,60

Port	Vlans in spanning tree forwarding state and not pruned
Fa0/13	1,10,20,30,40,50,60
Fa0/18	1,10,20,30,40,50,60
Fa0/20	1,10,20,30,40,50,60

1.5 Controlling Traffic over Trunk Ports

Configuration

```
SW4#
interface FastEthernet0/13
  switchport trunk allowed vlan remove 50
!
interface FastEthernet0/18
  switchport trunk allowed vlan remove 50
!
interface FastEthernet0/20
  switchport trunk allowed vlan remove 50
```

Verification

```
SW4#show interface trunk
```

Port	Mode	Encapsulation	Status	Native vlan
Fa0/13	on	802.1q	trunking	666
Fa0/18	on	802.1q	trunking	666
Fa0/20	on	802.1q	trunking	666

Port	Vlans allowed on trunk
Fa0/13	1-49,51-4094
Fa0/18	1-49,51-4094
Fa0/20	1-49,51-4094

Port	Vlans allowed and active in management domain
Fa0/13	1,10,20,30,40,60
Fa0/18	1,10,20,30,40,60
Fa0/20	1,10,20,30,40,60

Port	Vlans in spanning tree forwarding state and not pruned
Fa0/13	1,10,20,30,40,60
Fa0/18	1,10,20,30,40,60
Fa0/20	1,10,20,30,40,60

1.6 VLAN Trunk Protocol (VTP)

Configuration

```
SW1#
vtp domain DBM_INC
vtp mode server
vtp password WIDGETS
!
vlan 100
  name LOBBY
vlan 200
  name CONFERENCE_ROOM
vlan 300
  name CAFETERIA
!
interface FastEthernet0/10
  switchport mode access
  switchport access vlan 100
!
interface FastEthernet0/11
  switchport mode access
  switchport access vlan 100
```

```
SW2#
vtp domain DBM_INC
vtp mode client
vtp password WIDGETS
!
interface FastEthernet0/10
  switchport mode access
  switchport access vlan 200
!
interface FastEthernet0/11
  switchport mode access
  switchport access vlan 200
```

```
SW3#
vtp domain DBM_INC
vtp mode client
vtp password WIDGETS
```

```
SW4#
vtp domain DBM_INC
vtp mode client
vtp password WIDGETS
!
interface FastEthernet0/10
  switchport mode access
  switchport access vlan 300
!
interface FastEthernet0/11
  switchport mode access
  switchport access vlan 300
```

Verification

SW1#show vtp status

```
VTP Version : running VTP1 (VTP2 capable)
Configuration Revision : 4
Maximum VLANs supported locally : 1005
Number of existing VLANs : 14
VTP Operating Mode : Server
VTP Domain Name : DBM_INC
VTP Pruning Mode : Disabled
VTP V2 Mode : Disabled
VTP Traps Generation : Disabled
MD5 digest : 0xA3 0x6D 0x68 0x0A 0x90 0x95 0x19 0xFC
Configuration last modified by 0.0.0.0 at 3-1-93 06:08:50
Local updater ID is 0.0.0.0 (no valid interface found)
```

SW2#show vtp status

```
VTP Version : running VTP1 (VTP2 capable)
Configuration Revision : 4
Maximum VLANs supported locally : 1005
Number of existing VLANs : 14
VTP Operating Mode : Client
VTP Domain Name : DBM_INC
VTP Pruning Mode : Disabled
VTP V2 Mode : Disabled
VTP Traps Generation : Disabled
MD5 digest : 0xA3 0x6D 0x68 0x0A 0x90 0x95 0x19 0xFC
Configuration last modified by 0.0.0.0 at 3-1-93 06:08:50
```

SW3#show vtp status

```
VTP Version : running VTP1 (VTP2 capable)
Configuration Revision : 4
Maximum VLANs supported locally : 1005
Number of existing VLANs : 14
VTP Operating Mode : Client
VTP Domain Name : DBM_INC
VTP Pruning Mode : Disabled
VTP V2 Mode : Disabled
VTP Traps Generation : Disabled
MD5 digest : 0xA3 0x6D 0x68 0x0A 0x90 0x95 0x19 0xFC
Configuration last modified by 0.0.0.0 at 3-1-93 06:08:50
```

SW4#show vtp status

```
VTP Version : running VTP1 (VTP2 capable)
Configuration Revision : 4
Maximum VLANs supported locally : 1005
Number of existing VLANs : 14
VTP Operating Mode : Client
VTP Domain Name : DBM_INC
VTP Pruning Mode : Disabled
VTP V2 Mode : Disabled
VTP Traps Generation : Disabled
MD5 digest : 0xA3 0x6D 0x68 0x0A 0x90 0x95 0x19 0xFC
Configuration last modified by 0.0.0.0 at 3-1-93 06:08:50
```

SW1#show vlan brief

VLAN Name	Status	Ports
1 default	active	Fa0/3, Fa0/6, Fa0/9, Fa0/12 Fa0/14, Fa0/15, Fa0/17, Fa0/18 Fa0/20, Fa0/21, Fa0/22, Fa0/23 Fa0/24, Gi0/1, Gi0/2
10 SALES	active	Fa0/1, Fa0/8
20 ACCOUNTING	active	Fa0/4, Fa0/5
30 MANAGEMENT	active	
40 CUSTOMER_SERVICE	active	
50 WAREHOUSE	active	
60 GUEST_ACCESS	active	Fa0/2, Fa0/7
100 LOBBY	active	Fa0/10, Fa0/11
200 CONFERENCE_ROOM	active	
300 CAFETERIA	active	
1002 fddi-default	act/unsup	
1003 token-ring-default	act/unsup	
1004 fddinet-default	act/unsup	
1005 trnet-default	act/unsup	

SW2#show vlan brief

VLAN Name	Status	Ports
1 default	active	Fa0/4, Fa0/6, Fa0/7, Fa0/12 Fa0/14, Fa0/15, Fa0/16, Fa0/18 Fa0/19, Fa0/20, Fa0/22, Fa0/23 Fa0/24, Gi0/1, Gi0/2
10 SALES	active	
20 ACCOUNTING	active	Fa0/2
30 MANAGEMENT	active	Fa0/5, Fa0/8, Fa0/9
40 CUSTOMER_SERVICE	active	Fa0/1, Fa0/3
50 WAREHOUSE	active	
60 GUEST_ACCESS	active	
100 LOBBY	active	
200 CONFERENCE_ROOM	active	Fa0/10, Fa0/11
300 CAFETERIA	active	
1002 fddi-default	act/unsup	
1003 token-ring-default	act/unsup	
1004 fddinet-default	act/unsup	
1005 trnet-default	act/unsup	

SW3#show vlan brief

VLAN Name	Status	Ports
1 default	active	Fa0/1, Fa0/5, Fa0/6, Fa0/7 Fa0/8, Fa0/12, Fa0/14, Fa0/15 Fa0/16, Fa0/18, Fa0/19, Fa0/21 Fa0/22, Fa0/23, Fa0/24, Gi0/1 Gi0/2
10 SALES	active	Fa0/2, Fa0/3
20 ACCOUNTING	active	
30 MANAGEMENT	active	
40 CUSTOMER_SERVICE	active	
50 WAREHOUSE	active	Fa0/4, Fa0/9
60 GUEST_ACCESS	active	Fa0/10, Fa0/11
100 LOBBY	active	
200 CONFERENCE_ROOM	active	
300 CAFETERIA	active	
1002 fddi-default	act/unsup	
1003 token-ring-default	act/unsup	
1004 fddinet-default	act/unsup	
1005 trnet-default	act/unsup	

SW4#show vlan brief

VLAN Name	Status	Ports
1 default	active	Fa0/7, Fa0/8, Fa0/9, Fa0/12 Fa0/14, Fa0/15, Fa0/16, Fa0/17 Fa0/19, Fa0/21, Fa0/22, Fa0/23 Fa0/24, Gi0/1, Gi0/2
10 SALES	active	
20 ACCOUNTING	active	
30 MANAGEMENT	active	
40 CUSTOMER_SERVICE	active	
50 WAREHOUSE	active	Fa0/1, Fa0/2, Fa0/4, Fa0/6
60 GUEST_ACCESS	active	Fa0/3, Fa0/5
100 LOBBY	active	
200 CONFERENCE_ROOM	active	
300 CAFETERIA	active	Fa0/10, Fa0/11
1002 fddi-default	act/unsup	
1003 token-ring-default	act/unsup	
1004 fddinet-default	act/unsup	
1005 trnet-default	act/unsup	

1.7 VTP Pruning

Configuration

```
SW1#
vtp pruning

SW4#
interface FastEthernet0/13
  switchport trunk allowed vlan 1-4094
!
interface FastEthernet0/18
  switchport trunk allowed vlan 1-4094
!
interface FastEthernet0/20
  switchport trunk allowed vlan 1-4094
```

Verification

SW1#show vtp status

```
VTP Version                : running VTP1 (VTP2 capable)
Configuration Revision      : 5
Maximum VLANs supported locally : 1005
Number of existing VLANs    : 14
VTP Operating Mode         : Server
VTP Domain Name            : DBM_INC
VTP Pruning Mode           : Enabled
VTP V2 Mode                : Disabled
VTP Traps Generation       : Disabled
MD5 digest                 : 0x64 0x0E 0x09 0x7D 0x7E 0x53 0x9F 0xC8
Configuration last modified by 0.0.0.0 at 3-1-93 06:12:44
Local updater ID is 0.0.0.0 (no valid interface found)
```

SW2#show vtp status

```
VTP Version                : running VTP1 (VTP2 capable)
Configuration Revision      : 5
Maximum VLANs supported locally : 1005
Number of existing VLANs    : 14
VTP Operating Mode         : Client
VTP Domain Name            : DBM_INC
VTP Pruning Mode           : Enabled
VTP V2 Mode                : Disabled
VTP Traps Generation       : Disabled
MD5 digest                 : 0x64 0x0E 0x09 0x7D 0x7E 0x53 0x9F 0xC8
Configuration last modified by 0.0.0.0 at 3-1-93 06:12:44
```

SW3#show vtp status

```
VTP Version           : running VTP1 (VTP2 capable)
Configuration Revision : 5
Maximum VLANs supported locally : 1005
Number of existing VLANs : 14
VTP Operating Mode    : Client
VTP Domain Name       : DBM_INC
VTP Pruning Mode      : Enabled
VTP V2 Mode           : Disabled
VTP Traps Generation  : Disabled
MD5 digest            : 0x64 0x0E 0x09 0x7D 0x7E 0x53 0x9F 0xC8
Configuration last modified by 0.0.0.0 at 3-1-93 06:12:44
```

SW4#show vtp status

```
VTP Version           : running VTP1 (VTP2 capable)
Configuration Revision : 5
Maximum VLANs supported locally : 1005
Number of existing VLANs : 14
VTP Operating Mode    : Client
VTP Domain Name       : DBM_INC
VTP Pruning Mode      : Enabled
VTP V2 Mode           : Disabled
VTP Traps Generation  : Disabled
MD5 digest            : 0x64 0x0E 0x09 0x7D 0x7E 0x53 0x9F 0xC8
Configuration last modified by 0.0.0.0 at 3-1-93 06:12:44
```

SW1#show interface trunk

Port	Mode	Encapsulation	Status	Native vlan
Fa0/13	on	802.1q	trunking	666
Fa0/16	on	802.1q	trunking	666
Fa0/19	on	802.1q	trunking	666

Port	Vlans allowed on trunk
Fa0/13	1-4094
Fa0/16	1-4094
Fa0/19	1-4094

Port	Vlans allowed and active in management domain
Fa0/13	1,10,20,30,40,50,60,100,200,300
Fa0/16	1,10,20,30,40,50,60,100,200,300
Fa0/19	1,10,20,30,40,50,60,100,200,300

Port	Vlans in spanning tree forwarding state and not pruned
Fa0/13	none
Fa0/16	1,20,50
Fa0/19	none

SW2#show interface trunk

Port	Mode	Encapsulation	Status	Native vlan
Fa0/13	on	802.1q	trunking	666
Fa0/17	on	802.1q	trunking	666
Fa0/21	on	802.1q	trunking	666

Port	Vlans allowed on trunk
Fa0/13	1-4094
Fa0/17	1-4094
Fa0/21	1-4094

Port	Vlans allowed and active in management domain
Fa0/13	1,10,20,30,40,50,60,100,200,300
Fa0/17	1,10,20,30,40,50,60,100,200,300
Fa0/21	1,10,20,30,40,50,60,100,200,300

Port	Vlans in spanning tree forwarding state and not pruned
Fa0/13	1
Fa0/17	1,10,20
Fa0/21	none

SW3#show interface trunk

Port	Mode	Encapsulation	Status	Native vlan
Fa0/13	on	802.1q	trunking	666
Fa0/17	on	802.1q	trunking	666
Fa0/20	on	802.1q	trunking	666

Port	Vlans allowed on trunk
Fa0/13	1-4094
Fa0/17	1-4094
Fa0/20	1-4094

Port	Vlans allowed and active in management domain
Fa0/13	1,10,20,30,40,50,60,100,200,300
Fa0/17	1,10,20,30,40,50,60,100,200,300
Fa0/20	1,10,20,30,40,50,60,100,200,300

Port	Vlans in spanning tree forwarding state and not pruned
Fa0/13	1,10,20
Fa0/17	1,20
Fa0/20	1

SW4#show interface trunk

Port	Mode	Encapsulation	Status	Native vlan
Fa0/13	on	802.1q	trunking	666
Fa0/18	on	802.1q	trunking	666
Fa0/20	on	802.1q	trunking	666

Port	Vlans allowed on trunk
Fa0/13	1-4094
Fa0/18	1-4094
Fa0/20	1-4094

Port	Vlans allowed and active in management domain
Fa0/13	1,10,20,30,40,50,60,100,200,300
Fa0/18	1,10,20,30,40,50,60,100,200,300
Fa0/20	1,10,20,30,40,50,60,100,200,300

Port	Vlans in spanning tree forwarding state and not pruned
Fa0/13	1
Fa0/18	1
Fa0/20	1,10,20

1.8 VTP Transparent Mode

Configuration

```
SW1#  
vtp mode transparent
```

```
SW2#  
vtp mode transparent
```

```
SW3#  
vtp mode transparent
```

```
SW4#  
vtp mode transparent
```

Verification

SW1#show vtp status

```
VTP Version : running VTP1 (VTP2 capable)  
Configuration Revision : 0  
Maximum VLANs supported locally : 1005  
Number of existing VLANs : 14  
VTP Operating Mode : Transparent  
VTP Domain Name : DBM_INC  
VTP Pruning Mode : Enabled  
VTP V2 Mode : Disabled  
VTP Traps Generation : Disabled  
MD5 digest : 0x64 0x0E 0x09 0x7D 0x7E 0x53 0x9F 0xC8  
Configuration last modified by 0.0.0.0 at 3-1-93 06:12:44
```

SW2#show vtp status

```
VTP Version : running VTP1 (VTP2 capable)  
Configuration Revision : 0  
Maximum VLANs supported locally : 1005  
Number of existing VLANs : 14  
VTP Operating Mode : Transparent  
VTP Domain Name : DBM_INC  
VTP Pruning Mode : Enabled  
VTP V2 Mode : Disabled  
VTP Traps Generation : Disabled  
MD5 digest : 0x64 0x0E 0x09 0x7D 0x7E 0x53 0x9F 0xC8  
Configuration last modified by 0.0.0.0 at 3-1-93 06:12:44
```

SW3#show vtp status

```
VTP Version : running VTP1 (VTP2 capable)
Configuration Revision : 0
Maximum VLANs supported locally : 1005
Number of existing VLANs : 14
VTP Operating Mode : Transparent
VTP Domain Name : DBM_INC
VTP Pruning Mode : Enabled
VTP V2 Mode : Disabled
VTP Traps Generation : Disabled
MD5 digest : 0x64 0x0E 0x09 0x7D 0x7E 0x53 0x9F 0xC8
Configuration last modified by 0.0.0.0 at 3-1-93 06:12:44
```

SW4#show vtp status

```
VTP Version : running VTP1 (VTP2 capable)
Configuration Revision : 0
Maximum VLANs supported locally : 1005
Number of existing VLANs : 14
VTP Operating Mode : Transparent
VTP Domain Name : DBM_INC
VTP Pruning Mode : Enabled
VTP V2 Mode : Disabled
VTP Traps Generation : Disabled
MD5 digest : 0x64 0x0E 0x09 0x7D 0x7E 0x53 0x9F 0xC8
Configuration last modified by 0.0.0.0 at 3-1-93 06:12:44
```

1.9 Spanning-Tree Protocol

Configuration

```
SW1#
spanning-tree vlan 10 priority 0
spanning-tree vlan 20 priority 16384
!
interface FastEthernet0/14
  switchport trunk encapsulation dot1q
  switchport mode trunk
  spanning-tree vlan 20 cost 1
  no shutdown

SW2#
spanning-tree vlan 20 priority 0
spanning-tree vlan 10 priority 16384
!
interface FastEthernet0/14
  switchport trunk encapsulation dot1q
  switchport mode trunk
  spanning-tree vlan 10 cost 1
  no shutdown
```

Verification

SW1#show spanning-tree vlan 10

```
VLAN0010
Spanning tree enabled protocol ieee
Root ID Priority 10
Address 001f.6d94.7b80
This bridge is the root
Hello Time 2 sec Max Age 20 sec Forward Delay 15 sec

Bridge ID Priority 10 (priority 0 sys-id-ext 10)
Address 001f.6d94.7b80
Hello Time 2 sec Max Age 20 sec Forward Delay 15 sec
Aging Time 300

Interface Role Sts Cost Prio.Nbr Type
-----
Fa0/1 Desg FWD 19 128.3 P2p
Fa0/13 Desg FWD 19 128.15 P2p
Fa0/14 Desg FWD 19 128.16 P2p
Fa0/16 Desg FWD 19 128.18 P2p
Fa0/19 Desg FWD 19 128.21 P2p
```

SW2#show spanning-tree vlan 10

```
VLAN0010
Spanning tree enabled protocol ieee
Root ID Priority 10
Address 001f.6d94.7b80
Cost 1
Port 16 (FastEthernet0/14)
Hello Time 2 sec Max Age 20 sec Forward Delay 15 sec

Bridge ID Priority 16394 (priority 16384 sys-id-ext 10)
Address 001f.2711.d580
Hello Time 2 sec Max Age 20 sec Forward Delay 15 sec
Aging Time 300

Interface Role Sts Cost Prio.Nbr Type
-----
Fa0/13 Altn BLK 19 128.15 P2p
Fa0/14 Root FWD 1 128.16 P2p
Fa0/17 Desg FWD 19 128.19 P2p
Fa0/21 Desg FWD 19 128.23 P2p
```

SW1#show spanning-tree vlan 20

```
VLAN0020
Spanning tree enabled protocol ieee
Root ID Priority 20
      Address 001f.2711.d580
      Cost 1
      Port 16 (FastEthernet0/14)
      Hello Time 2 sec Max Age 20 sec Forward Delay 15 sec

Bridge ID Priority 16404 (priority 16384 sys-id-ext 20)
      Address 001f.6d94.7b80
      Hello Time 2 sec Max Age 20 sec Forward Delay 15 sec
      Aging Time 300
```

Interface	Role	Sts	Cost	Prio.Nbr	Type
Fa0/5	Desg	FWD	19	128.7	P2p
Fa0/13	Altn	BLK	19	128.15	P2p
Fa0/14	Root	FWD	1	128.16	P2p
Fa0/16	Desg	FWD	19	128.18	P2p
Fa0/19	Desg	FWD	19	128.21	P2p

SW2#show spanning-tree vlan 20

```
VLAN0020
Spanning tree enabled protocol ieee
Root ID Priority 20
      Address 001f.2711.d580
      This bridge is the root
      Hello Time 2 sec Max Age 20 sec Forward Delay 15 sec

Bridge ID Priority 20 (priority 0 sys-id-ext 20)
      Address 001f.2711.d580
      Hello Time 2 sec Max Age 20 sec Forward Delay 15 sec
      Aging Time 300
```

Interface	Role	Sts	Cost	Prio.Nbr	Type
Fa0/2	Desg	FWD	19	128.4	P2p
Fa0/13	Desg	FWD	19	128.15	P2p
Fa0/14	Desg	FWD	19	128.16	P2p
Fa0/17	Desg	FWD	19	128.19	P2p
Fa0/21	Desg	FWD	19	128.23	P2p

 **Note**

By comparing the Layer 3 ARP table on the end hosts and the Layer 2 CAM table on the switches, the actual forwarding path determined by Spanning-Tree Protocol can be verified.

R5#ping 10.20.25.2

Type escape sequence to abort.

Sending 5, 100-byte ICMP Echos to 10.20.25.2, timeout is 2 seconds:

!!!!

Success rate is 100 percent (5/5), round-trip min/avg/max = 1/2/4 ms

R5#show arp

Protocol	Address	Age (min)	Hardware Addr	Type	Interface
Internet	10.20.25.2	33	000d.65c2.f1c0	ARPA	FastEthernet0/0
Internet	10.20.25.5	-	001a.6cd5.04a4	ARPA	FastEthernet0/0

SW1#show mac-address-table dynamic vlan 20

Mac Address Table

```

-----
Vlan      Mac Address          Type           Ports
-----
  20      000d.65c2.f1c0      DYNAMIC       Fa0/14
  20      001a.6cd5.04a4      DYNAMIC       Fa0/5
  20      001f.2711.d590      DYNAMIC       Fa0/14

```

Total Mac Addresses for this criterion: 3

1.10 Rapid PVST+

Configuration

```
SW1#  
spanning-tree mode rapid-pvst  
spanning-tree portfast default
```

```
SW2#  
spanning-tree mode rapid-pvst  
spanning-tree portfast default
```

```
SW3#  
spanning-tree mode rapid-pvst  
spanning-tree portfast default
```

```
SW4#  
spanning-tree mode rapid-pvst  
spanning-tree portfast default
```

Verification

SW1#show spanning-tree vlan 20

VLAN0020

Spanning tree enabled protocol rstp

```

Root ID      Priority    20
             Address    0019.5684.8700
             Cost        1
             Port        16 (FastEthernet0/14)
             Hello Time  2 sec  Max Age 20 sec  Forward Delay 15 sec
    
```

```

Bridge ID   Priority    16404 (priority 16384 sys-id-ext 20)
             Address    0019.55f8.9b80
             Hello Time  2 sec  Max Age 20 sec  Forward Delay 15 sec
             Aging Time 300
    
```

Interface	Role	Sts	Cost	Prio.Nbr	Type
Fa0/5	Desg	FWD	19	128.7	P2p Edge
Fa0/13	Altn	BLK	19	128.15	P2p
Fa0/14	Root	FWD	1	128.16	P2p
Fa0/16	Desg	FWD	19	128.18	P2p
Fa0/19	Desg	FWD	19	128.21	P2p

SW2#show spanning-tree vlan 20

VLAN0020

Spanning tree enabled protocol rstp

```

Root ID      Priority    20
             Address    0019.5684.8700
             This bridge is the root
             Hello Time  2 sec  Max Age 20 sec  Forward Delay 15 sec
    
```

```

Bridge ID   Priority    20 (priority 0 sys-id-ext 20)
             Address    0019.5684.8700
             Hello Time  2 sec  Max Age 20 sec  Forward Delay 15 sec
             Aging Time 300
    
```

Interface	Role	Sts	Cost	Prio.Nbr	Type
Fa0/2	Desg	FWD	19	128.4	P2p Edge
Fa0/13	Desg	FWD	19	128.15	P2p
Fa0/14	Desg	FWD	19	128.16	P2p
Fa0/17	Desg	FWD	19	128.19	P2p
Fa0/21	Desg	FWD	19	128.23	P2p

SW3#show spanning-tree vlan 20

VLAN0020

Spanning tree enabled protocol rstp

```

Root ID    Priority    20
           Address    0019.5684.8700
           Cost      19
           Port      17 (FastEthernet0/17)
           Hello Time  2 sec  Max Age 20 sec  Forward Delay 15 sec
    
```

```

Bridge ID  Priority    32788 (priority 32768 sys-id-ext 20)
           Address    000d.28c3.4d00
           Hello Time  2 sec  Max Age 20 sec  Forward Delay 15 sec
           Aging Time 300
    
```

Interface	Role	Sts	Cost	Prio.Nbr	Type
Fa0/13	Altn	BLK	19	128.13	P2p
Fa0/17	Root	FWD	19	128.17	P2p
Fa0/20	Altn	BLK	19	128.20	P2p

SW4#show spanning-tree vlan 20

VLAN0020

Spanning tree enabled protocol rstp

```

Root ID    Priority    20
           Address    0019.5684.8700
           Cost      19
           Port      18 (FastEthernet0/18)
           Hello Time  2 sec  Max Age 20 sec  Forward Delay 15 sec
    
```

```

Bridge ID  Priority    32788 (priority 32768 sys-id-ext 20)
           Address    000c.3058.7c80
           Hello Time  2 sec  Max Age 20 sec  Forward Delay 15 sec
           Aging Time 300
    
```

Interface	Role	Sts	Cost	Prio.Nbr	Type
Fa0/13	Altn	BLK	19	128.13	P2p
Fa0/18	Root	FWD	19	128.18	P2p
Fa0/20	Desg	FWD	19	128.20	P2p

1.11 Multiple Spanning-Tree Protocol

Configuration

```
SW1#
spanning-tree mode mst
!
spanning-tree mst configuration
name DBM_INC
revision 10
instance 1 vlan 10, 30, 50
instance 2 vlan 20, 40, 60
instance 3 vlan 100, 200, 300
!
spanning-tree mst 1 priority 0
spanning-tree mst 2 priority 16384
!
interface FastEthernet0/14
spanning-tree mst 2 cost 1
```

```
SW2#
spanning-tree mode mst
!
spanning-tree mst configuration
name DBM_INC
revision 10
instance 1 vlan 10, 30, 50
instance 2 vlan 20, 40, 60
instance 3 vlan 100, 200, 300
!
spanning-tree mst 2 priority 0
spanning-tree mst 1 priority 16384
!
interface FastEthernet0/14
spanning-tree mst 1 cost 1
```

```
SW3#
spanning-tree mode mst
!
spanning-tree mst configuration
name DBM_INC
revision 10
instance 1 vlan 10, 30, 50
instance 2 vlan 20, 40, 60
instance 3 vlan 100, 200, 300
```

```
SW4#
spanning-tree mode mst
!
spanning-tree mst configuration
  name DBM_INC
  revision 10
  instance 1 vlan 10, 30, 50
  instance 2 vlan 20, 40, 60
  instance 3 vlan 100, 200, 300
```

Verification

SW1#show spanning-tree mst 1

```
##### MST1      vlans mapped:  10,30,50
Bridge          address 001f.6d94.7b80  priority      1      (0 sysid 1)
Root            this switch for MST1
```

Interface	Role	Sts	Cost	Prio.Nbr	Type
Fa0/1	Desg	FWD	200000	128.3	P2p Edge
Fa0/13	Desg	FWD	200000	128.15	P2p
Fa0/14	Desg	FWD	200000	128.16	P2p
Fa0/16	Desg	FWD	200000	128.18	P2p
Fa0/19	Desg	FWD	200000	128.21	P2p

SW1#show spanning-tree mst 2

```
##### MST2      vlans mapped:  20,40,60
Bridge          address 001f.6d94.7b80  priority      16386 (16384 sysid 2)
Root            address 001f.2711.d580  priority      2      (0 sysid 2)
                  port      Fa0/14      cost          1          rem hops 19
```

Interface	Role	Sts	Cost	Prio.Nbr	Type
Fa0/5	Desg	FWD	200000	128.7	P2p Edge
Fa0/13	Altn	BLK	200000	128.15	P2p
Fa0/14	Root	FWD	1	128.16	P2p
Fa0/16	Desg	FWD	200000	128.18	P2p
Fa0/19	Desg	FWD	200000	128.21	P2p

SW1#show spanning-tree mst 3

```
##### MST3      vlans mapped:  100,200,300
Bridge          address 001f.6d94.7b80  priority      32771 (32768 sysid 3)
Root            address 000f.f76d.ac80  priority      32771 (32768 sysid 3)
                  port      Fa0/16      cost          200000    rem hops 19
```

Interface	Role	Sts	Cost	Prio.Nbr	Type
Fa0/13	Altn	BLK	200000	128.15	P2p
Fa0/14	Altn	BLK	200000	128.16	P2p
Fa0/16	Root	FWD	200000	128.18	P2p
Fa0/19	Altn	BLK	200000	128.21	P2p

SW2#show spanning-tree mst 1

```
##### MST1      vlans mapped: 10,30,50
Bridge          address 001f.2711.d580  priority      16385 (16384 sysid 1)
Root           address 001f.6d94.7b80  priority      1 (0 sysid 1)
               port      Fa0/14      cost          1          rem hops 19
```

Interface	Role	Sts	Cost	Prio.Nbr	Type
Fa0/13	Altn	BLK	200000	128.15	P2p
Fa0/14	Root	FWD 1		128.16	P2p
Fa0/17	Desg	FWD	200000	128.19	P2p
Fa0/21	Desg	FWD	200000	128.23	P2p

SW2#show spanning-tree mst 2

```
##### MST2      vlans mapped: 20,40,60
Bridge          address 001f.2711.d580  priority      2 (0 sysid 2)
Root           this switch for MST2
```

Interface	Role	Sts	Cost	Prio.Nbr	Type
Fa0/2	Desg	FWD	200000	128.4	P2p Edge
Fa0/13	Desg	FWD	200000	128.15	P2p
Fa0/14	Desg	FWD	200000	128.16	P2p
Fa0/17	Desg	FWD	200000	128.19	P2p
Fa0/21	Desg	FWD	200000	128.23	P2p

SW2#show spanning-tree mst 3

```
##### MST3      vlans mapped: 100,200,300
Bridge          address 001f.2711.d580  priority      32771 (32768 sysid 3)
Root           address 00f.f76d.ac80  priority      32771 (32768 sysid 3)
               port      Fa0/17      cost          200000    rem hops 19
```

Interface	Role	Sts	Cost	Prio.Nbr	Type
Fa0/13	Desg	FWD	200000	128.15	P2p
Fa0/14	Desg	FWD	200000	128.16	P2p
Fa0/17	Root	FWD	200000	128.19	P2p
Fa0/21	Altn	BLK	200000	128.23	P2p

1.12 Spanning-Tree Protocol Features

Configuration

```
SW1#
interface FastEthernet0/10
 spanning-tree bpduguard enable
!
interface FastEthernet0/11
 spanning-tree bpduguard enable
!
interface FastEthernet0/13
 uddl port aggressive
 spanning-tree guard loop
!
interface FastEthernet0/14
 uddl port aggressive
 spanning-tree guard loop
!
interface FastEthernet0/16
 uddl port aggressive
 spanning-tree guard loop
!
interface FastEthernet0/19
 uddl port aggressive
 spanning-tree guard loop
```

```
SW2#
interface FastEthernet0/10
 spanning-tree guard root
!
interface FastEthernet0/11
 spanning-tree guard root
!
interface FastEthernet0/13
 uddl port aggressive
 spanning-tree guard loop
!
interface FastEthernet0/14
 uddl port aggressive
 spanning-tree guard loop
!
interface FastEthernet0/17
 uddl port aggressive
 spanning-tree guard loop
!
interface FastEthernet0/21
 uddl port aggressive
 spanning-tree guard loop
```

```
SW3#
interface FastEthernet0/13
  udld port aggressive
  spanning-tree guard loop
!
interface FastEthernet0/17
  udld port aggressive
  spanning-tree guard loop
!
interface FastEthernet0/20
  udld port aggressive
  spanning-tree guard loop
```

```
SW4#
interface FastEthernet0/10
  spanning-tree bpdufilter enable
!
interface FastEthernet0/11
  spanning-tree bpdufilter enable
!
interface FastEthernet0/13
  udld port aggressive
  spanning-tree guard loop
!
interface FastEthernet0/18
  udld port aggressive
  spanning-tree guard loop
!
interface FastEthernet0/20
  udld port aggressive
  spanning-tree guard loop
```

1.13 EtherChannel

Configuration

```
SW1#
default interface range fa0/13 , fa0/14 , fa0/16 , fa0/17
!
interface FastEthernet0/13
  switchport trunk encapsulation dot1q
  switchport mode trunk
  channel-group 12 mode on
!
interface FastEthernet0/14
  switchport trunk encapsulation dot1q
  switchport mode trunk
  channel-group 12 mode on
!
interface FastEthernet0/16
  switchport trunk encapsulation dot1q
  switchport mode trunk
  channel-group 13 mode desirable
!
interface FastEthernet0/17
  switchport trunk encapsulation dot1q
  switchport mode trunk
  channel-group 13 mode desirable

SW2#
default interface range fa0/13 , fa0/14 , fa0/19 , fa0/21
!
interface FastEthernet0/13
  switchport trunk encapsulation dot1q
  switchport mode trunk
  channel-group 12 mode on
!
interface FastEthernet0/14
  switchport trunk encapsulation dot1q
  switchport mode trunk
  channel-group 12 mode on
!
interface FastEthernet0/19
  switchport trunk encapsulation dot1q
  switchport mode trunk
  channel-group 24 mode active
!
interface FastEthernet0/21
  switchport trunk encapsulation dot1q
  switchport mode trunk
  channel-group 24 mode active
```

```
SW3#
default interface range fa0/13 , fa0/14
!
interface FastEthernet0/13
  switchport trunk encapsulation dot1q
  switchport mode trunk
  channel-group 13 mode desirable
!
interface FastEthernet0/14
  switchport trunk encapsulation dot1q
  switchport mode trunk
  channel-group 13 mode desirable
```

```
SW4#
default interface range fa0/16 , fa0/18
!
interface FastEthernet0/16
  switchport trunk encapsulation dot1q
  switchport mode trunk
  channel-group 24 mode active
!
interface FastEthernet0/18
  switchport trunk encapsulation dot1q
  switchport mode trunk
  channel-group 24 mode active
```

Verification

SW1#show etherchannel summary

```
Flags: D - down          P - bundled in port-channel
       I - stand-alone  s - suspended
       H - Hot-standby (LACP only)
       R - Layer3       S - Layer2
       U - in use       f - failed to allocate aggregator

       M - not in use, minimum links not met
       u - unsuitable for bundling
       w - waiting to be aggregated
       d - default port
```

```
Number of channel-groups in use: 2
Number of aggregators:          2
```

Group	Port-channel	Protocol	Ports	
12	Po12(SU)	-	Fa0/13(P)	Fa0/14(P)
13	Po13(SU)	PAgP	Fa0/16(P)	Fa0/17(P)

SW2#show etherchannel summary

```
Flags: D - down          P - bundled in port-channel
       I - stand-alone  s - suspended
       H - Hot-standby (LACP only)
       R - Layer3       S - Layer2
       U - in use       f - failed to allocate aggregator

       M - not in use, minimum links not met
       u - unsuitable for bundling
       w - waiting to be aggregated
       d - default port
```

```
Number of channel-groups in use: 2
Number of aggregators:          2
```

Group	Port-channel	Protocol	Ports	
12	Po12(SU)	-	Fa0/13(P)	Fa0/14(P)
24	Po24(SU)	LACP	Fa0/19(P)	Fa0/21(P)

SW3#show etherchannel summary

Flags: D - down P - bundled in port-channel
I - stand-alone s - suspended
H - Hot-standby (LACP only)
R - Layer3 S - Layer2
U - in use f - failed to allocate aggregator

M - not in use, minimum links not met
u - unsuitable for bundling
w - waiting to be aggregated
d - default port

Number of channel-groups in use: 1
Number of aggregators: 1

Group	Port-channel	Protocol	Ports
13	Po13(SU)	PAgP	Fa0/13(P) Fa0/14(P)

SW4#show etherchannel summary

Flags: D - down P - bundled in port-channel
I - stand-alone s - suspended
H - Hot-standby (LACP only)
R - Layer3 S - Layer2
U - in use f - failed to allocate aggregator

M - not in use, minimum links not met
u - unsuitable for bundling
w - waiting to be aggregated
d - default port

Number of channel-groups in use: 1
Number of aggregators: 1

Group	Port-channel	Protocol	Ports
24	Po24(SU)	LACP	Fa0/16(P) Fa0/18(P)

SW1#show interface trunk

Port	Mode	Encapsulation	Status	Native vlan
Fa0/19	on	802.1q	trunking	666
Po12	on	802.1q	trunking	1
Po13	on	802.1q	trunking	1

Port	Vlans allowed on trunk
Fa0/19	1-4094
Po12	1-4094
Po13	1-4094

Port	Vlans allowed and active in management domain
Fa0/19	1,10,20,30,40,50,60,100,200,300
Po12	1,10,20,30,40,50,60,100,200,300
Po13	1,10,20,30,40,50,60,100,200,300

Port	Vlans in spanning tree forwarding state and not pruned
Fa0/19	1,10,20,30,40,50,60,100,200,300
Po12	10,20,30,40,50,60
Po13	10,20,30,40,50,60

SW2#show interface trunk

Port	Mode	Encapsulation	Status	Native vlan
Fa0/17	on	802.1q	trunking	666
Po12	on	802.1q	trunking	1
Po24	on	802.1q	trunking	1

Port	Vlans allowed on trunk
Fa0/17	1-4094
Po12	1-4094
Po24	1-4094

Port	Vlans allowed and active in management domain
Fa0/17	1,10,20,30,40,50,60,100,200,300
Po12	1,10,20,30,40,50,60,100,200,300
Po24	1,10,20,30,40,50,60,100,200,300

Port	Vlans in spanning tree forwarding state and not pruned
Fa0/17	1,10,20,30,40,50,60,100,200,300
Po12	1,10,20,30,40,50,60,100,200,300
Po24	1,10,20,30,40,50,60,100,200,300

SW3#show interface trunk

Port	Mode	Encapsulation	Status	Native vlan
Fa0/17	on	802.1q	trunking	666
Fa0/20	on	802.1q	trunking	666
Po13	on	802.1q	trunking	1

Port	Vlans allowed on trunk
Fa0/17	1-4094
Fa0/20	1-4094
Po13	1-4094

Port	Vlans allowed and active in management domain
Fa0/17	1,10,20,30,40,50,60,100,200,300
Fa0/20	1,10,20,30,40,50,60,100,200,300
Po13	1,10,20,30,40,50,60,100,200,300

Port	Vlans in spanning tree forwarding state and not pruned
Fa0/17	20,40,60
Fa0/20	1,10,30,50,100,200,300
Po13	1,10,30,50,100,200,300

SW4#show interface trunk

Port	Mode	Encapsulation	Status	Native vlan
Fa0/13	on	802.1q	trunking	666
Fa0/20	on	802.1q	trunking	666
Po24	on	802.1q	trunking	1

Port	Vlans allowed on trunk
Fa0/13	1-4094
Fa0/20	1-4094
Po24	1-4094

Port	Vlans allowed and active in management domain
Fa0/13	1,10,20,30,40,50,60,100,200,300
Fa0/20	1,10,20,30,40,50,60,100,200,300
Po24	1,10,20,30,40,50,60,100,200,300

Port	Vlans in spanning tree forwarding state and not pruned
Fa0/13	1,10,30,50,100,200,300
Fa0/20	1,20,40,60,100,200,300
Po24	1,20,40,60,100,200,300

SW1#show spanning-tree mst 1

```
##### MST1      vlans mapped: 10,30,50
Bridge            address 0019.55f8.9b80  priority      1      (0 sysid 1)
Root              this switch for MST1
```

Interface	Role	Sts	Cost	Prio.Nbr	Type
Fa0/1	Desg	FWD	200000	128.3	P2p Edge
Fa0/19	Desg	FWD	200000	128.21	P2p
Po12	Desg	FWD	100000	128.144	P2p
Po13	Desg	FWD	100000	128.152	P2p

1.14 Inter-VLAN Routing

Configuration

```
R1:
interface FastEthernet0/0
  no shutdown
  no ip address
!
interface FastEthernet0/0.10
  encapsulation dot1Q 10
  ip address 10.10.13.1 255.255.255.0
!
interface FastEthernet0/0.20
  encapsulation dot1Q 20
  ip address 10.20.25.1 255.255.255.0
!
interface FastEthernet0/0.30
  encapsulation dot1Q 30
  ip address 10.30.30.1 255.255.255.0
!
router rip
  version 2
  network 10.0.0.0

R2:
ip route 0.0.0.0 0.0.0.0 10.20.25.1

R3:
ip route 0.0.0.0 0.0.0.0 10.10.13.1

R4:
ip route 0.0.0.0 0.0.0.0 10.50.46.7

R5:
ip route 0.0.0.0 0.0.0.0 10.20.25.1

R6:
ip route 0.0.0.0 0.0.0.0 10.50.46.7
```

```
SW1:
ip routing
!
interface FastEthernet0/1
  switchport trunk encapsulation dot1q
  switchport trunk allowed vlan 10,20,30
  switchport mode trunk
!
interface Vlan30
  ip address 10.30.30.7 255.255.255.0
!
interface Vlan40
  ip address 10.40.40.7 255.255.255.0
!
interface Vlan50
  ip address 10.50.46.7 255.255.255.0
!
interface Vlan60
  ip address 10.60.60.7 255.255.255.0
!
interface Vlan100
  ip address 10.100.100.7 255.255.255.0
!
interface Vlan200
  ip address 10.200.200.7 255.255.255.0
!
interface Vlan300
  ip address 10.1.44.7 255.255.255.0
!
router rip
  version 2
  network 10.0.0.0
```

Verification

R1#show ip route

Codes: C - connected, S - static, R - RIP, M - mobile, B - BGP
D - EIGRP, EX - EIGRP external, O - OSPF, IA - OSPF inter area
N1 - OSPF NSSA external type 1, N2 - OSPF NSSA external type 2
E1 - OSPF external type 1, E2 - OSPF external type 2
i - IS-IS, su - IS-IS summary, L1 - IS-IS level-1, L2 - IS-IS level-2
ia - IS-IS inter area, * - candidate default, U - per-user static route
o - ODR, P - periodic downloaded static route

Gateway of last resort is not set

```
10.0.0.0/24 is subnetted, 9 subnets
C    10.20.25.0 is directly connected, FastEthernet0/0.20
R    10.200.200.0 [120/1] via 10.30.30.7, 00:00:02, FastEthernet0/0.30
R    10.100.100.0 [120/1] via 10.30.30.7, 00:00:02, FastEthernet0/0.30
R    10.60.60.0 [120/1] via 10.30.30.7, 00:00:02, FastEthernet0/0.30
R    10.40.40.0 [120/1] via 10.30.30.7, 00:00:02, FastEthernet0/0.30
C    10.30.30.0 is directly connected, FastEthernet0/0.30
C    10.10.13.0 is directly connected, FastEthernet0/0.10
R    10.50.46.0 [120/1] via 10.30.30.7, 00:00:03, FastEthernet0/0.30
R    10.1.44.0 [120/1] via 10.30.30.7, 00:00:03, FastEthernet0/0.30
```

SW1#show ip route

Codes: C - connected, S - static, R - RIP, M - mobile, B - BGP
D - EIGRP, EX - EIGRP external, O - OSPF, IA - OSPF inter area
N1 - OSPF NSSA external type 1, N2 - OSPF NSSA external type 2
E1 - OSPF external type 1, E2 - OSPF external type 2
i - IS-IS, su - IS-IS summary, L1 - IS-IS level-1, L2 - IS-IS level-2
ia - IS-IS inter area, * - candidate default, U - per-user static route
o - ODR, P - periodic downloaded static route

Gateway of last resort is not set

```
10.0.0.0/24 is subnetted, 9 subnets
R    10.20.25.0 [120/1] via 10.30.30.1, 00:00:20, Vlan30
C    10.200.200.0 is directly connected, Vlan200
C    10.100.100.0 is directly connected, Vlan100
C    10.60.60.0 is directly connected, Vlan60
C    10.40.40.0 is directly connected, Vlan40
C    10.30.30.0 is directly connected, Vlan30
R    10.10.13.0 [120/1] via 10.30.30.1, 00:00:20, Vlan30
C    10.50.46.0 is directly connected, Vlan50
C    10.1.44.0 is directly connected, Vlan300
```

R2#ping 10.10.13.1

Type escape sequence to abort.
Sending 5, 100-byte ICMP Echos to 10.10.13.1, timeout is 2 seconds:
!!!!
Success rate is 100 percent (5/5), round-trip min/avg/max = 1/2/4 ms

R2#ping 10.10.13.3

Type escape sequence to abort.
Sending 5, 100-byte ICMP Echos to 10.10.13.3, timeout is 2 seconds:
!!!!
Success rate is 100 percent (5/5), round-trip min/avg/max = 1/3/4 ms

R2#ping 10.50.46.4

Type escape sequence to abort.
Sending 5, 100-byte ICMP Echos to 10.50.46.4, timeout is 2 seconds:
!!!!
Success rate is 100 percent (5/5), round-trip min/avg/max = 1/3/4 ms

R2#ping 10.50.46.6

Type escape sequence to abort.
Sending 5, 100-byte ICMP Echos to 10.50.46.6, timeout is 2 seconds:
!!!!
Success rate is 100 percent (5/5), round-trip min/avg/max = 1/2/4 ms

1.15 Port Security

Configuration

```
SW2:
interface FastEthernet0/10
  switchport port-security maximum 4
  switchport port-security
  switchport port-security violation protect
!
interface FastEthernet0/11
  switchport port-security maximum 4
  switchport port-security
  switchport port-security violation protect

SW4:
errdisable recovery cause psecure-violation
errdisable recovery interval 120
!
interface FastEthernet0/10
  switchport port-security
  switchport port-security mac-address 0045.ca0c.e801
!
interface FastEthernet0/11
  switchport port-security
  switchport port-security mac-address 0045.ca0c.e802
```

Verification

```
SW2#show port-security interface Fa0/10
Port Security           : Enabled
Port Status             : Secure-down
Violation Mode          : Protect
Aging Time              : 0 mins
Aging Type              : Absolute
SecureStatic Address Aging : Disabled
Maximum MAC Addresses   : 4
Total MAC Addresses     : 0
Configured MAC Addresses : 0
Sticky MAC Addresses    : 0
Last Source Address:Vlan : 0000.0000.0000:0
Security Violation Count : 0
```

```
SW2#show port-security interface Fa0/11
Port Security           : Enabled
Port Status             : Secure-down
Violation Mode          : Protect
Aging Time              : 0 mins
Aging Type              : Absolute
SecureStatic Address Aging : Disabled
Maximum MAC Addresses   : 4
Total MAC Addresses     : 0
Configured MAC Addresses : 0
Sticky MAC Addresses    : 0
Last Source Address:Vlan : 0000.0000.0000:0
Security Violation Count : 0
```

SW4#show port-security interface Fa0/10

```
Port Security           : Enabled
Port Status             : Secure-down
Violation Mode          : Shutdown
Aging Time              : 0 mins
Aging Type              : Absolute
SecureStatic Address Aging : Disabled
Maximum MAC Addresses   : 1
Total MAC Addresses     : 1
Configured MAC Addresses : 1
Sticky MAC Addresses    : 0
Last Source Address:Vlan : 0000.0000.0000:0
Security Violation Count : 0
```

SW4#show port-security interface Fa0/11

```
Port Security           : Enabled
Port Status             : Secure-down
Violation Mode          : Shutdown
Aging Time              : 0 mins
Aging Type              : Absolute
SecureStatic Address Aging : Disabled
Maximum MAC Addresses   : 1
Total MAC Addresses     : 1
Configured MAC Addresses : 1
Sticky MAC Addresses    : 0
Last Source Address:Vlan : 0000.0000.0000:0
Security Violation Count : 0
```

1.16 802.1X Authentication

Configuration

```
SW1:
aaa new-model
aaa authentication dot1x default group radius
!
dot1x system-auth-control
!
interface FastEthernet0/10
  dot1x port-control auto
  dot1x timeout reauth-period 300
  dot1x reauthentication
!
interface FastEthernet0/11
  dot1x port-control auto
  dot1x timeout reauth-period 300
  dot1x reauthentication
!
radius-server host 10.10.13.100 key DBM_RADIUS
```

Verification

SW1#show dot1x all

```
Sysauthcontrol          Enabled
Dot1x Protocol Version      2
Critical Recovery Delay    100
Critical EAPOL             Disabled
```

Dot1x Info for FastEthernet0/10

```
-----
PAE                      = AUTHENTICATOR
PortControl              = AUTO
ControlDirection        = Both
HostMode                 = SINGLE_HOST
Violation Mode          = PROTECT
ReAuthentication        = Enabled
QuietPeriod             = 60
ServerTimeout           = 0
SuppTimeout             = 30
ReAuthPeriod            = 300 (Locally configured)
ReAuthMax               = 2
MaxReq                  = 2
TxPeriod                = 30
RateLimitPeriod         = 0
```

Dot1x Info for FastEthernet0/11

```
-----
PAE                      = AUTHENTICATOR
PortControl              = AUTO
ControlDirection        = Both
HostMode                 = SINGLE_HOST
Violation Mode          = PROTECT
ReAuthentication        = Enabled
QuietPeriod             = 60
ServerTimeout           = 0
SuppTimeout             = 30
ReAuthPeriod            = 300 (Locally configured)
ReAuthMax               = 2
MaxReq                  = 2
TxPeriod                = 30
RateLimitPeriod         = 0
```

1.17 VLAN Access Lists

Configuration

```
SW1:
vlan access-map GUEST_ACCESS_VACL 10
  action forward
  match ip address HTTP_AND_HTTPS
!
vlan access-map GUEST_ACCESS_VACL 20
  action drop
  match ip address ALL_IP
!
vlan filter GUEST_ACCESS_VACL vlan-list 60
!
ip access-list extended ALL_IP
  permit ip any any
!
ip access-list extended HTTP_AND_HTTPS
  permit tcp any any eq www
  permit tcp any eq www any
  permit tcp any any eq 443
  permit tcp any eq 443 any

SW3:
vlan access-map GUEST_ACCESS_VACL 10
  action forward
  match ip address HTTP_AND_HTTPS
!
vlan access-map GUEST_ACCESS_VACL 20
  action drop
  match ip address ALL_IP
!
vlan filter GUEST_ACCESS_VACL vlan-list 60
!
ip access-list extended ALL_IP
  permit ip any any
!
ip access-list extended HTTP_AND_HTTPS
  permit tcp any any eq www
  permit tcp any eq www any
  permit tcp any any eq 443
  permit tcp any eq 443 any
```

```
SW4:
vlan access-map GUEST_ACCESS_VACL 10
  action forward
  match ip address HTTP_AND_HTTPS
!
vlan access-map GUEST_ACCESS_VACL 20
  action drop
  match ip address ALL_IP
!
vlan filter GUEST_ACCESS_VACL vlan-list 60
!
ip access-list extended ALL_IP
  permit ip any any
!
ip access-list extended HTTP_AND_HTTPS
  permit tcp any any eq www
  permit tcp any eq www any
  permit tcp any any eq 443
  permit tcp any eq 443 any
```

1.18 DHCP Snooping & DAI

Configuration

```
SW4:
ip dhcp snooping vlan 50
ip dhcp snooping
ip arp inspection vlan 50
ip arp inspection filter VLAN50 vlan 50
!
interface FastEthernet0/1
 ip dhcp snooping trust
!
arp access-list VLAN50
 permit ip host 10.50.46.4 mac host 001a.6c30.9a5d
 permit ip host 10.50.46.6 mac host 001a.6cd5.0e13
```

Verification

```
SW4#show ip arp inspection
```

```
Source Mac Validation      : Disabled
Destination Mac Validation : Disabled
IP Address Validation      : Disabled
```

Vlan	Configuration	Operation	ACL Match	Static ACL
50	Enabled	Active	VLAN50	No

Vlan	ACL Logging	DHCP Logging	Probe Logging
50	Deny	Deny	Off

Vlan	Forwarded	Dropped	DHCP Drops	ACL Drops
50	2	20	20	0

Vlan	DHCP Permits	ACL Permits	Probe Permits	Source MAC Failures
50	0	2	0	0

Vlan	Dest MAC Failures	IP Validation Failures	Invalid Protocol Data
50	0	0	0

 **Note**

Dynamic ARP Inspection can be verified by removing the ARP ACL, and testing that connectivity is denied between R4 and R6. The log information on SW4 also indicates that the ARPs are being dropped because no entry exists in the DHCP Snooping binding database or in an ARP ACL. Once the ARP ACL is reapplied connectivity is successful.

```
SW4#config t
Enter configuration commands, one per line. End with CNTL/Z.
SW4(config)#no ip arp inspection filter VLAN50 vlan 50
SW4(config)#
```

```
R4#clear arp
R4#ping 10.50.46.6
```

```
Type escape sequence to abort.
Sending 5, 100-byte ICMP Echos to 10.50.46.6, timeout is 2 seconds:
.....
Success rate is 0 percent (0/5)
```

```
SW4#
*Mar 1 20:05:41.975: %SW_DAI-4-DHCP_SNOOPING_DENY: 1 Invalid ARPs
(Res) on Fa0/4, vlan
50.([001a.6c30.9a5d/10.50.46.4/ffff.ffff.ffff/10.50.46.4/20:05:41 UTC
Mon Mar 1 1993])
*Mar 1 20:05:41.975: %SW_DAI-4-DHCP_SNOOPING_DENY: 1 Invalid ARPs
(Req) on Fa0/4, vlan
50.([001a.6c30.9a5d/10.50.46.4/001a.6cd5.0e13/10.50.46.6/20:05:41 UTC
Mon Mar 1 1993])
*Mar 1 20:05:51.975: %SW_DAI-4-DHCP_SNOOPING_DENY: 1 Invalid ARPs
(Req) on Fa0/4, vlan
50.([001a.6c30.9a5d/10.50.46.4/001a.6cd5.0e13/10.50.46.6/20:05:51 UTC
Mon Mar 1 1993])
*Mar 1 20:05:56.975: %SW_DAI-4-DHCP_SNOOPING_DENY: 1 Invalid ARPs
(Res) on Fa0/6, vlan
50.([001a.6cd5.0e13/10.50.46.6/ffff.ffff.ffff/10.50.46.6/20:05:56 UTC
<output omitted>
```

```
SW4#config t
Enter configuration commands, one per line. End with CNTL/Z.
SW4(config)#ip arp inspection filter VLAN50 vlan 50
SW4(config)#end
SW4#
```

```
R4#ping 10.50.46.6
```

```
Type escape sequence to abort.
Sending 5, 100-byte ICMP Echos to 10.50.46.6, timeout is 2 seconds:
.!!!!
Success rate is 80 percent (4/5), round-trip min/avg/max = 1/1/4 ms
```

1.19 Private VLANs

Configuration

```
SW1:
vlan 2000
  name EMAIL
  private-vlan isolated
!
vlan 3000
  name WWW
  private-vlan community
!
vlan 1000
  name DMZ
  private-vlan primary
  private-vlan association 2000,3000
!
interface FastEthernet0/3
  switchport private-vlan mapping 1000 2000,3000
  switchport mode private-vlan promiscuous
!
interface FastEthernet0/6
  switchport private-vlan host-association 1000 2000
  switchport mode private-vlan host
!
interface FastEthernet0/9
  switchport private-vlan host-association 1000 3000
  switchport mode private-vlan host
!
interface FastEthernet0/12
  switchport private-vlan host-association 1000 3000
  switchport mode private-vlan host
```

Verification

SW1#show vlan

VLAN	Name	Status	Ports
1	default	active	Fa0/15, Fa0/18, Fa0/20, Fa0/21 Fa0/22, Fa0/23, Fa0/24, Gi0/1 Gi0/2
10	SALES	active	Fa0/8
20	ACCOUNTING	active	Fa0/4, Fa0/5
30	MANAGEMENT	active	
40	CUSTOMER_SERVICE	active	
50	WAREHOUSE	active	
60	GUEST_ACCESS	active	Fa0/2, Fa0/7
100	LOBBY	active	Fa0/10, Fa0/11
200	CONFERENCE_ROOM	active	
300	CAFETERIA	active	
1000	DMZ	active	
1002	fddi-default	act/unsup	
1003	token-ring-default	act/unsup	
1004	fddinet-default	act/unsup	
1005	trnet-default	act/unsup	
2000	EMAIL	active	
3000	WWW	active	

VLAN	Type	SAID	MTU	Parent	RingNo	BridgeNo	Stp	BrdgMode	Trans1	Trans2
1	enet	100001	1500	-	-	-	-	-	0	0
10	enet	100010	1500	-	-	-	-	-	0	0
20	enet	100020	1500	-	-	-	-	-	0	0
30	enet	100030	1500	-	-	-	-	-	0	0
40	enet	100040	1500	-	-	-	-	-	0	0
50	enet	100050	1500	-	-	-	-	-	0	0
60	enet	100060	1500	-	-	-	-	-	0	0
100	enet	100100	1500	-	-	-	-	-	0	0
200	enet	100200	1500	-	-	-	-	-	0	0
300	enet	100300	1500	-	-	-	-	-	0	0
1000	enet	101000	1500	-	-	-	-	-	0	0
1002	fddi	101002	1500	-	-	-	-	-	0	0
1003	tr	101003	1500	-	-	-	-	-	0	0
1004	fdnet	101004	1500	-	-	-	ieee	-	0	0
1005	trnet	101005	1500	-	-	-	ibm	-	0	0
2000	enet	102000	1500	-	-	-	-	-	0	0
3000	enet	103000	1500	-	-	-	-	-	0	0

Remote SPAN VLANs

Primary	Secondary	Type	Ports
1000	2000	isolated	Fa0/3, Fa0/6
1000	3000	community	Fa0/3, Fa0/9, Fa0/12

SW1#show vlan private-vlan type

Vlan	Type
1000	primary
2000	isolated
3000	community

1.20 HSRP

Configuration

```
R1:
interface FastEthernet0/0
 standby 1 ip 10.100.14.254
 standby 1 timers msec 333 1
 standby 1 priority 255
 standby 1 preempt delay minimum 30
 standby 1 authentication md5 key-string DBM_HSRP
 standby 1 track Serial0/1 255
```

```
R4:
interface FastEthernet0/0
 standby 1 ip 10.100.14.254
 standby 1 timers msec 333 1
 standby 1 preempt
 standby 1 authentication md5 key-string DBM_HSRP
```

Verification

```
R1#show standby
```

```
FastEthernet0/0 - Group 1
  State is Active
    11 state changes, last state change 00:00:09
  Virtual IP address is 10.100.14.254
  Active virtual MAC address is 0000.0c07.ac01
    Local virtual MAC address is 0000.0c07.ac01 (v1 default)
  Hello time 333 msec, hold time 1 sec
    Next hello sent in 0.261 secs
  Authentication MD5, key-string "DBM_HSRP"
  Preemption enabled, delay min 30 secs
  Active router is local
  Standby router is 10.100.14.4, priority 100 (expires in 0.703 sec)
  Priority 255 (configured 255)
    Track interface Serial0/1 state Up decrement 255
  IP redundancy name is "hsrp-Fa0/0-1" (default)
```

```
R4#show standby
```

```
FastEthernet0/0 - Group 1
  State is Standby
    10 state changes, last state change 00:01:03
  Virtual IP address is 10.100.14.254
  Active virtual MAC address is 0000.0c07.ac01
    Local virtual MAC address is 0000.0c07.ac01 (v1 default)
  Hello time 333 msec, hold time 1 sec
    Next hello sent in 0.096 secs
  Authentication MD5, key-string "DBM_HSRP"
  Preemption enabled
  Active router is 10.100.14.1, priority 255 (expires in 0.992 sec)
  Standby router is local
  Priority 100 (default 100)
  Group name is "hsrp-Fa0/0-1" (default)
```

 **Note**

The below output illustrates how the reconvergence process of HSRP can be verified. To start, R2 sees the virtual IP & MAC address for 10.100.14.254 in its ARP table. A PING is initiated from R2 out to the Internet (3.3.3.3), and then R1's link to the ISP is disabled. Based on the low OSPF & HSRP hello timers, reconvergence occurs in about 4 seconds.

```
R2#show arp
Protocol  Address          Age (min)  Hardware Addr  Type   Interface
Internet  10.100.14.2      -          0011.2058.0fe0 ARPA    FastEthernet0/0
Internet  10.100.14.254   0          0000.0c07.ac01 ARPA    FastEthernet0/0
```

```
R2#ping 3.3.3.3 repeat 1000
```

```
Type escape sequence to abort.
Sending 1000, 100-byte ICMP Echos to 3.3.3.3, timeout is 2 seconds:
!!!!!!!!!!!!!!!!!!!!!!!!!!!!!!!!!!!!!!!!!!!!!!!!!!!!!!!!!!!!!!!!!!!!!!!!!!!!!!
!!!!!!!!!!!!!!!!!!!!!!!!!!!!!!!!!!!!!!!!!!!!!!!!!!!!!!!!!!!!!!!!!!!!!!!!!!!!!!
<output omitted>
```

```
R1#config t
Enter configuration commands, one per line.  End with CNTL/Z.
R1(config)#interface Serial0/1
R1(config-if)#shutdown
R1(config-if)#
R1(config-if)#
*Mar  1 00:21:13.231: %OSPF-5-ADJCHG: Process 1, Nbr 3.3.3.3 on
Serial0/1 from FULL to DOWN, Neighbor Down: Interface down or detached
*Mar  1 00:21:13.403: %HSRP-5-STATECHANGE: FastEthernet0/0 Grp 1 state
Active -> Speak
*Mar  1 00:21:14.405: %HSRP-5-STATECHANGE: FastEthernet0/0 Grp 1 state
Speak -> Standby
*Mar  1 00:21:15.230: %LINK-5-CHANGED: Interface Serial0/1, changed
state to administratively down
*Mar  1 00:21:16.232: %LINEPROTO-5-UPDOWN: Line protocol on Interface
Serial0/1, changed state to down
```

```
R2#
!!!..!!!!!!!!!!!!!!!!!!!!!!!!!!!!!!!!!!!!!!!!!!!!!!!!!!!!!!!!!!!!!!!!!!!!!!!!!!!!!!
!!!!!!!!!!!!!!!!!!!!!!!!!!!!!!!!!!!!!!!!!!!!!!!!!!!!!!!!!!!!!!!!!!!!!!!!!!!!!!
!!!!!!!!!!!!!!!!!!!!!!!!!!!!!!!!!!!!!!!!!!!!!!!!!!!!!!!!!!!!!!!!!!!!!!!!!!!!!!
!!!!!!!!!!!!!!!!!!!!!!!!!!!!!!!!!!!!!!!!!!!!!!!!!!!!!!!!!!!!!!!!!!!!!!!!!!!!!!
!!!!!!!!!!!!!!!!!!!!!!!!!!!!!!!!!!!!!!!!!!!!!!!!!!!!!!!!!!!!!!!!!!!!!!!!!!!!!!
<output omitted>
Success rate is 99 percent (998/1000), round-trip min/avg/max = 28/30/101 ms
```

R1#show standby

FastEthernet0/0 - Group 1

State is Standby

7 state changes, last state change 00:00:48
Virtual IP address is 10.100.14.254
Active virtual MAC address is 0000.0c07.ac01
Local virtual MAC address is 0000.0c07.ac01 (v1 default)
Hello time 333 msec, hold time 1 sec
Next hello sent in 0.193 secs
Authentication MD5, key-string "DBM_HSRP"
Preemption enabled
Active router is 10.100.14.4, priority 100 (expires in 0.700 sec)
Standby router is local
Priority 0 (configured 255)
Track interface Serial0/1 state Down decrement 255
IP redundancy name is "hsrp-Fa0/0-1" (default)

R4#show standby

FastEthernet0/0 - Group 1

State is Active

5 state changes, last state change 00:00:54
Virtual IP address is 10.100.14.254
Active virtual MAC address is 0000.0c07.ac01
Local virtual MAC address is 0000.0c07.ac01 (v1 default)
Hello time 333 msec, hold time 1 sec
Next hello sent in 0.096 secs
Authentication MD5, key-string
Preemption enabled
Active router is local
Standby router is 10.100.14.1, priority 0 (expires in 0.864 sec)
Priority 100 (default 100)
Group name is "hsrp-Fa0/0-1" (default)

R2#traceroute 3.3.3.3

Type escape sequence to abort.

Tracing the route to 3.3.3.3

```
1 10.100.14.4 0 msec 0 msec 4 msec
2 172.16.45.5 12 msec 12 msec 16 msec
3 172.16.35.3 17 msec * 12 msec
```

Traffic now exits via R4's link to ISP2, as R4 is the active HSRP router.

When R1's link to ISP1 comes back, the preempt delay of 30 seconds allows for the IGP network to fully reconverge before R1 regains its active status. This can be seen from the timestamps of the log messages on R1.

```
R1#config t
Enter configuration commands, one per line.  End with CNTL/Z.
R1(config)#interface Serial0/1
R1(config-if)#no shutdown
R1(config-if)#end
R1#
*Mar  1 00:23:53.553: %SYS-5-CONFIG_I: Configured from console by console
*Mar  1 00:23:54.788: %LINK-3-UPDOWN: Interface Serial0/1, changed state to up
*Mar  1 00:23:55.216: %OSPF-5-ADJCHG: Process 1, Nbr 3.3.3.3 on Serial0/1 from
LOADING to FULL, Loading Done
*Mar  1 00:23:55.789: %LINEPROTO-5-UPDOWN: Line protocol on Interface
Serial0/1, changed state to up
*Mar  1 00:24:24.845: %HSRP-5-STATECHANGE: FastEthernet0/0 Grp 1 state Standby
-> Active

R1#show standby
FastEthernet0/0 - Group 1
  State is Active
    11 state changes, last state change 00:00:09
  Virtual IP address is 10.100.14.254
  Active virtual MAC address is 0000.0c07.ac01
    Local virtual MAC address is 0000.0c07.ac01 (v1 default)
  Hello time 333 msec, hold time 1 sec
    Next hello sent in 0.261 secs
  Authentication MD5, key-string "DBM_HSRP"
  Preemption enabled, delay min 30 secs
  Active router is local
  Standby router is 10.100.14.4, priority 100 (expires in 0.703 sec)
  Priority 255 (configured 255)
    Track interface Serial0/1 state Up decrement 255
  IP redundancy name is "hsrp-Fa0/0-1" (default)
```

1.21 VRRP

Configuration

```
R1:
interface FastEthernet0/0
 vrrp 1 ip 10.100.14.254
 vrrp 1 timers advertise msec 333
 vrrp 1 preempt delay minimum 30
 vrrp 1 priority 254
 vrrp 1 authentication md5 key-string DBM_HSRP
 vrrp 1 track 10 decrement 253
!
track 10 interface Serial0/1 line-protocol
```

```
R4:
interface FastEthernet0/0
 vrrp 1 ip 10.100.14.254
 vrrp 1 timers advertise msec 333
 vrrp 1 preempt
 vrrp 1 authentication md5 key-string DBM_HSRP
```

Verification

R1#show vrrp

```
FastEthernet0/0 - Group 1
  State is Master
  Virtual IP address is 10.100.14.254
  Virtual MAC address is 0000.5e00.0101
  Advertisement interval is 0.333 sec
  Preemption enabled, delay min 30 secs
  Priority is 254
    Track object 10 state Up decrement 253
  Authentication MD5, key-string "DBM_HSRP"
  Master Router is 10.100.14.1 (local), priority is 254
  Master Advertisement interval is 0.333 sec
  Master Down interval is 1.006 sec
```

R4#show vrrp

```
FastEthernet0/0 - Group 1
  State is Backup
  Virtual IP address is 10.100.14.254
  Virtual MAC address is 0000.5e00.0101
  Advertisement interval is 0.333 sec
  Preemption enabled
  Priority is 100
  Authentication MD5, key-string
  Master Router is 10.100.14.1, priority is 254
  Master Advertisement interval is 1.000 sec
  Master Down interval is 1.608 sec (expires in 1.600 sec)
```

 **Note**

Similar to the previous HSRP verification, the traceroute and ARP cache on R2 indicate that R1 is the master VRRP router, and that traffic exits to the Internet via the ISP1 link to R3.

R2#traceroute 3.3.3.3

Type escape sequence to abort.
Tracing the route to 3.3.3.3

```
 1 10.100.14.1 0 msec 4 msec 0 msec
 2 172.16.13.3 12 msec * 16 msec
```

R2#traceroute 5.5.5.5

Type escape sequence to abort.
Tracing the route to 5.5.5.5

```
 1 10.100.14.1 0 msec 4 msec 4 msec
 2 172.16.13.3 12 msec 12 msec 12 msec
 3 172.16.35.5 16 msec * 12 msec
```

R2#show arp

Protocol	Address	Age (min)	Hardware Addr	Type	Interface
Internet	10.100.14.1	4	000d.bc01.3400	ARPA	FastEthernet0/0
Internet	10.100.14.2	-	0011.2058.0fe0	ARPA	FastEthernet0/0
Internet	10.100.14.4	5	001a.6c30.9a5c	ARPA	FastEthernet0/0
Internet	10.100.14.254	1	0000.5e00.0101	ARPA	FastEthernet0/0

To verify the reconvergence time, a PING is sent from R2 to 3.3.3.3, and R1's link to ISP1 is disabled. Based on the packet loss it can be seen that reconvergence takes about four seconds end-to-end.

R2#ping 3.3.3.3 repeat 1000

Type escape sequence to abort.
Sending 1000, 100-byte ICMP Echos to 3.3.3.3, timeout is 2 seconds:
!!
!!
<output omitted>

```
R1#config t
Enter configuration commands, one per line.  End with CNTL/Z.
R1(config)#interface Serial0/1
R1(config-if)#shutdown
R1(config-if)#end
R1#
*Mar  1 00:43:36.473: %OSPF-5-ADJCHG: Process 1, Nbr 3.3.3.3 on Serial0/1 from
FULL to DOWN, Neighbor Down: Interface down or detached
*Mar  1 00:43:37.170: %SYS-5-CONFIG_I: Configured from console by console
*Mar  1 00:43:37.831: %VRRP-6-STATECHANGE: Fa0/0 Grp 1 state Master -> Backup
*Mar  1 00:43:38.472: %LINK-5-CHANGED: Interface Serial0/1, changed state to
administratively down
*Mar  1 00:43:39.474: %LINEPROTO-5-UPDOWN: Line protocol on Interface
Serial0/1, changed state to down
```

```
R2#
!!!.....!!!!!!!!!!!!!!!!!!!!!!!!!!!!!!!!!!!!!!!!!!!!!!!!!!!!!!!!!!!!!!!!!!!!!!
!!!!!!!!!!!!!!!!!!!!!!!!!!!!!!!!!!!!!!!!!!!!!!!!!!!!!!!!!!!!!!!!!!!!!!!!!!!!!!
!!!!!!!!!!!!!!!!!!!!!!!!!!!!!!!!!!!!!!!!!!!!!!!!!!!!!!!!!!!!!!!!!!!!!!!!!!!!!!
!!!!!!!!!!!!!!!!!!!!!!!!!!!!!!!!!!!!!!!!!!!!!!!!!!!!!!!!!!!!!!!!!!!!!!!!!!!!!!
<output omitted>
Success rate is 99 percent (998/1000), round-trip min/avg/max = 28/30/101 ms
```

```
R1#show vrrp
FastEthernet0/0 - Group 1
  State is Backup
  Virtual IP address is 10.100.14.254
  Virtual MAC address is 0000.5e00.0101
  Advertisement interval is 0.333 sec
  Preemption enabled, delay min 30 secs
  Priority is 1 (cfgd 254)
  Track object 10 state Down decrement 253
  Authentication MD5, key-string "DBM_HSRP"
  Master Router is 10.100.14.4, priority is 100
  Master Advertisement interval is 1.000 sec
  Master Down interval is 1.006 sec (expires in 0.721 sec)
```

```
R4#show vrrp
FastEthernet0/0 - Group 1
  State is Master
  Virtual IP address is 10.100.14.254
  Virtual MAC address is 0000.5e00.0101
  Advertisement interval is 0.333 sec
  Preemption enabled
  Priority is 100
  Authentication MD5, key-string
  Master Router is 10.100.14.4 (local), priority is 100
  Master Advertisement interval is 0.333 sec
  Master Down interval is 1.608 sec
```

R4 is now the Master Router, as verified through the traceroute output from R2.

R2#traceroute 3.3.3.3

Type escape sequence to abort.

Tracing the route to 3.3.3.3

```

 1 10.100.14.4 0 msec 4 msec 0 msec
 2 172.16.45.5 16 msec 16 msec 16 msec
 3 172.16.35.3 16 msec * 12 msec
    
```

R2#traceroute 5.5.5.5

Type escape sequence to abort.

Tracing the route to 5.5.5.5

```

 1 10.100.14.4 4 msec 0 msec 4 msec
 2 172.16.45.5 16 msec * 12 msec
    
```

When R1's link to ISP1 comes back, preemption occurs only after the 30 second timer expires to allow for IGP convergence.

R1#config t

Enter configuration commands, one per line. End with CNTL/Z.

R1(config)#interface Serial0/1

R1(config-if)#no shut

R1(config-if)#end

R1#

```

*Mar 1 00:44:43.174: %SYS-5-CONFIG_I: Configured from console by console
*Mar 1 00:44:44.572: %LINK-3-UPDOWN: Interface Serial0/1, changed state to up
*Mar 1 00:44:45.033: %OSPF-5-ADJCHG: Process 1, Nbr 3.3.3.3 on Serial0/1 from
LOADING to FULL, Loading Done
*Mar 1 00:44:45.574: %LINEPROTO-5-UPDOWN: Line protocol on Interface
Serial0/1, changed state to up
*Mar 1 00:45:14.830: %VRRP-6-STATECHANGE: Fa0/0 Grp 1 state Backup -> Master
    
```

1.22 GLBP

Configuration

R1:

```
interface FastEthernet0/0
  glbp 1 ip 10.100.14.254
  glbp 1 timers msec 333 1
  glbp 1 preempt
  glbp 1 weighting 2
  glbp 1 load-balancing weighted
  glbp 1 authentication md5 key-string DBM_HSRP
  glbp 1 weighting track 10 decrement 2
  glbp 1 forwarder preempt delay minimum 0
!
track 10 interface Serial0/1 line-protocol
```

R4:

```
interface FastEthernet0/0
  glbp 1 ip 10.100.14.254
  glbp 1 timers msec 333 1
  glbp 1 preempt
  glbp 1 weighting 1
  glbp 1 load-balancing weighted
  glbp 1 authentication md5 key-string DBM_HSRP
  glbp 1 weighting track 10 decrement 1
  glbp 1 forwarder preempt delay minimum 0
!
track 10 interface Serial0/1/0 line-protocol
```

Verification

```
R1#show glbp
FastEthernet0/0 - Group 1
  State is Active
    2 state changes, last state change 00:19:35
  Virtual IP address is 10.100.14.254
  Hello time 333 msec, hold time 1 sec
    Next hello sent in 0.161 secs
  Redirect time 600 sec, forwarder time-out 14400 sec
  Authentication MD5, key-string "DBM_HSRP"
  Preemption enabled, min delay 0 sec
  Active is local
  Standby is 10.100.14.4, priority 100 (expires in 0.892 sec)
  Priority 100 (default)
  Weighting 2 (configured 2), thresholds: lower 1, upper 2
    Track object 10 state Up decrement 2
  Load balancing: weighted
  Group members:
    000d.bc01.3400 (10.100.14.1) local
    001a.6c30.9a5c (10.100.14.4) authenticated
  There are 2 forwarders (1 active)
  Forwarder 1
    State is Active
      5 state changes, last state change 00:00:50
    MAC address is 0007.b400.0101 (default)
    Owner ID is 000d.bc01.3400
    Redirection enabled
    Preemption enabled, min delay 0 sec
    Active is local, weighting 2
    Arp replies sent: 1
  Forwarder 2
    State is Listen
    MAC address is 0007.b400.0102 (learnt)
    Owner ID is 001a.6c30.9a5c
    Redirection enabled, 599.892 sec remaining (maximum 600 sec)
    Time to live: 14399.892 sec (maximum 14400 sec)
    Preemption enabled, min delay 0 sec
    Active is 10.100.14.4 (primary), weighting 1 (expires in 0.888 sec)
    Arp replies sent: 1
```

R4#show glbp

```
FastEthernet0/0 - Group 1
  State is Standby
    1 state change, last state change 00:17:25
  Virtual IP address is 10.100.14.254
  Hello time 333 msec, hold time 1 sec
    Next hello sent in 0.288 secs
  Redirect time 600 sec, forwarder timeout 14400 sec
  Authentication MD5, key-string
  Preemption enabled, min delay 0 sec
  Active is 10.100.14.1, priority 100 (expires in 0.832 sec)
  Standby is local
  Priority 100 (default)
  Weighting 1 (configured 1), thresholds: lower 1, upper 1
    Track object 10 state Up decrement 1
  Load balancing: weighted
  Group members:
    000d.bc01.3400 (10.100.14.1) authenticated
    001a.6c30.9a5c (10.100.14.4) local
  There are 2 forwarders (1 active)
  Forwarder 1
    State is Listen
      4 state changes, last state change 00:00:55
      MAC address is 0007.b400.0101 (learnt)
      Owner ID is 000d.bc01.3400
      Time to live: 14399.712 sec (maximum 14400 sec)
      Preemption enabled, min delay 0 sec
      Active is 10.100.14.1 (primary), weighting 2 (expires in 0.800 sec)
  Forwarder 2
    State is Active
      1 state change, last state change 00:17:25
      MAC address is 0007.b400.0102 (default)
      Owner ID is 001a.6c30.9a5c
      Preemption enabled, min delay 0 sec
      Active is local, weighting 1
```

 **Note**

Note that unlike HSRP or VRRP, GLBP allows for multiple forwards on the link at the same time. This is illustrated by the ARP cache of R2 and R6. Although they both use the same virtual IP address 10.100.14.254 as their gateway to reach the destination 3.3.3.3, the ARP replies are load balanced between R1 and R4 based on the weightings values applied. Assuming a larger equal distribution of clients on the segment, R1 would service twice as many clients as R4.

R2#ping 3.3.3.3

Type escape sequence to abort.

Sending 5, 100-byte ICMP Echos to 3.3.3.3, timeout is 2 seconds:

!!!!

Success rate is 100 percent (5/5), round-trip min/avg/max = 28/30/32 ms

R2#show arp

Protocol	Address	Age (min)	Hardware Addr	Type	Interface
Internet	10.100.14.1	14	000d.bc01.3400	ARPA	FastEthernet0/0
Internet	10.100.14.2	-	0011.2058.0fe0	ARPA	FastEthernet0/0
Internet	10.100.14.4	14	001a.6c30.9a5c	ARPA	FastEthernet0/0
Internet	10.100.14.6	14	001a.6cd5.0e12	ARPA	FastEthernet0/0
Internet	10.100.14.254	15	0007.b400.0101	ARPA	FastEthernet0/0

R6#ping 3.3.3.3

Type escape sequence to abort.

Sending 5, 100-byte ICMP Echos to 3.3.3.3, timeout is 2 seconds:

!!!!

Success rate is 100 percent (5/5), round-trip min/avg/max = 28/28/32 ms

R6#show arp

Protocol	Address	Age (min)	Hardware Addr	Type	Interface
Internet	10.100.14.1	15	000d.bc01.3400	ARPA	FastEthernet0/0
Internet	10.100.14.2	14	0011.2058.0fe0	ARPA	FastEthernet0/0
Internet	10.100.14.4	15	001a.6c30.9a5c	ARPA	FastEthernet0/0
Internet	10.100.14.6	-	001a.6cd5.0e12	ARPA	FastEthernet0/0
Internet	10.100.14.254	14	0007.b400.0102	ARPA	FastEthernet0/0

R2's traffic exits via ISP1, while R6's traffic exits via ISP2.

R2#traceroute 3.3.3.3

Type escape sequence to abort.
Tracing the route to 3.3.3.3

```
 1 10.100.14.1 4 msec 0 msec 4 msec
 2 172.16.13.3 16 msec * 16 msec
```

R6#traceroute 3.3.3.3

Type escape sequence to abort.
Tracing the route to 3.3.3.3

```
 1 10.100.14.4 4 msec 0 msec 0 msec
 2 172.16.45.5 16 msec 12 msec 16 msec
 3 172.16.35.3 16 msec * 12 msec
```

Like the previous HSRP and VRRP designs, reconvergence of a failed forwarder happens in about 4 seconds.

R2#ping 3.3.3.3 repeat 1000

Type escape sequence to abort.
Sending 1000, 100-byte ICMP Echos to 3.3.3.3, timeout is 2 seconds:
!!
!!
<output omitted>

R1#config t

Enter configuration commands, one per line. End with CNTL/Z.

R1(config)#interface Serial0/1

R1(config-if)#shutdown

R1(config-if)#end

R1#

*Mar 1 01:08:38.455: %OSPF-5-ADJCHG: Process 1, Nbr 3.3.3.3 on Serial0/1 from FULL to DOWN, Neighbor Down: Interface down or detached

*Mar 1 01:08:38.683: %GLBP-6-FWDSTATECHANGE: FastEthernet0/0 Grp 1 Fwd 1 state **Active -> Listen**

*Mar 1 01:08:38.751: %SYS-5-CONFIG_I: Configured from console by console

*Mar 1 01:08:40.454: %LINK-5-CHANGED: Interface Serial0/1, changed state to administratively down

*Mar 1 01:08:41.456: %LINEPROTO-5-UPDOWN: Line protocol on Interface Serial0/1, changed state to down

R1#

```
R2#
!!..!!!!!!!!!!!!!!!!!!!!!!!!!!!!!!!!!!!!!!!!!!!!!!!!!!!!!!!!!!!!!!!!!!!!!!!!!!!!
!!!!!!!!!!!!!!!!!!!!!!!!!!!!!!!!!!!!!!!!!!!!!!!!!!!!!!!!!!!!!!!!!!!!!!!!!!!!
!!!!!!!!!!!!!!!!!!!!!!!!!!!!!!!!!!!!!!!!!!!!!!!!!!!!!!!!!!!!!!!!!!!!!!!!!!!!
<output omitted>
Success rate is 99 percent (998/1000), round-trip min/avg/max = 28/30/88 ms
```

R1 now indicates that there are still 2 Active Virtual Forwarders (AVFs), but R4 is servicing R1's previous forwarding address as the secondary.

```
R1#show glbp
FastEthernet0/0 - Group 1
  State is Active
    2 state changes, last state change 00:21:03
  Virtual IP address is 10.100.14.254
  Hello time 333 msec, hold time 1 sec
    Next hello sent in 0.201 secs
  Redirect time 600 sec, forwarder time-out 14400 sec
  Authentication MD5, key-string "DBM_HSRP"
  Preemption enabled, min delay 0 sec
  Active is local
  Standby is 10.100.14.4, priority 100 (expires in 0.992 sec)
  Priority 100 (default)
  Weighting 0, low (configured 2), thresholds: lower 1, upper 2
  Track object 10 state Down decrement 2
  Load balancing: weighted
  Group members:
    000d.bc01.3400 (10.100.14.1) local
    001a.6c30.9a5c (10.100.14.4) authenticated
  There are 2 forwarders (0 active)
  Forwarder 1
    State is Listen
      6 state changes, last state change 00:00:24
      MAC address is 0007.b400.0101 (default)
      Owner ID is 000d.bc01.3400
      Redirection enabled
      Preemption enabled, min delay 0 sec
      Active is 10.100.14.4 (secondary), weighting 1 (expires in 0.956
sec)
      Arp replies sent: 1
  Forwarder 2
    State is Listen
      MAC address is 0007.b400.0102 (learnt)
      Owner ID is 001a.6c30.9a5c
      Redirection enabled, 599.956 sec remaining (maximum 600 sec)
      Time to live: 14399.952 sec (maximum 14400 sec)
      Preemption enabled, min delay 0 sec
      Active is 10.100.14.4 (primary), weighting 1 (expires in 0.952 sec)
      Arp replies sent: 1
```

Building Scalable Cisco Internetworks (BSCI)

Case Study Overview

The next phase of network migration for Dexter Bean Manufacturing involves implementing a scalable Interior Gateway Protocol (IGP) for dynamic layer 3 IP routing between the various sites of DBM Inc, BGP for routing to the Internet, and various services such as Multicast, IPv6, DHCP, etc.

The scope of this implementation includes the four buildings in the main campus network of DBM Inc., HQ1, HQ2, the Branch, and the Warehouse, along with the two remote offices Remote1 and Remote2. The layer 2 trunks previously used as interconnections between the campus buildings have been replaced with layer 3 routed links, in order to eliminate the additional convergence time needed for STP. The two remote offices are connected to HQ1 and HQ2 through dual hub-and-spoke Frame Relay WAN links for redundancy. Internet connectivity occurs through redundant WAN links to ISP1 and ISP2 at the HQ1 and HQ2 offices respectively.

This case study is subdivided into various technology sections such as EIGRP, OSPF, IS-IS, BGP, Multicast, IPv6, and Services. Each section's configuration is unrelated to the others, and separate sets of initial configurations should be loaded per the included instructions before starting an individual section.

Use the enclosed logical layer 3 diagrams in order to configure the network per the architecture team's requirements. Note that there are minor differences between some diagrams, such as the EIGRP and OSPF network diagrams vs. the IS-IS network diagrams, due to the design limitations of running IS-IS over hub-and-spoke NBMA links.

DBM Inc. EIGRP Diagram

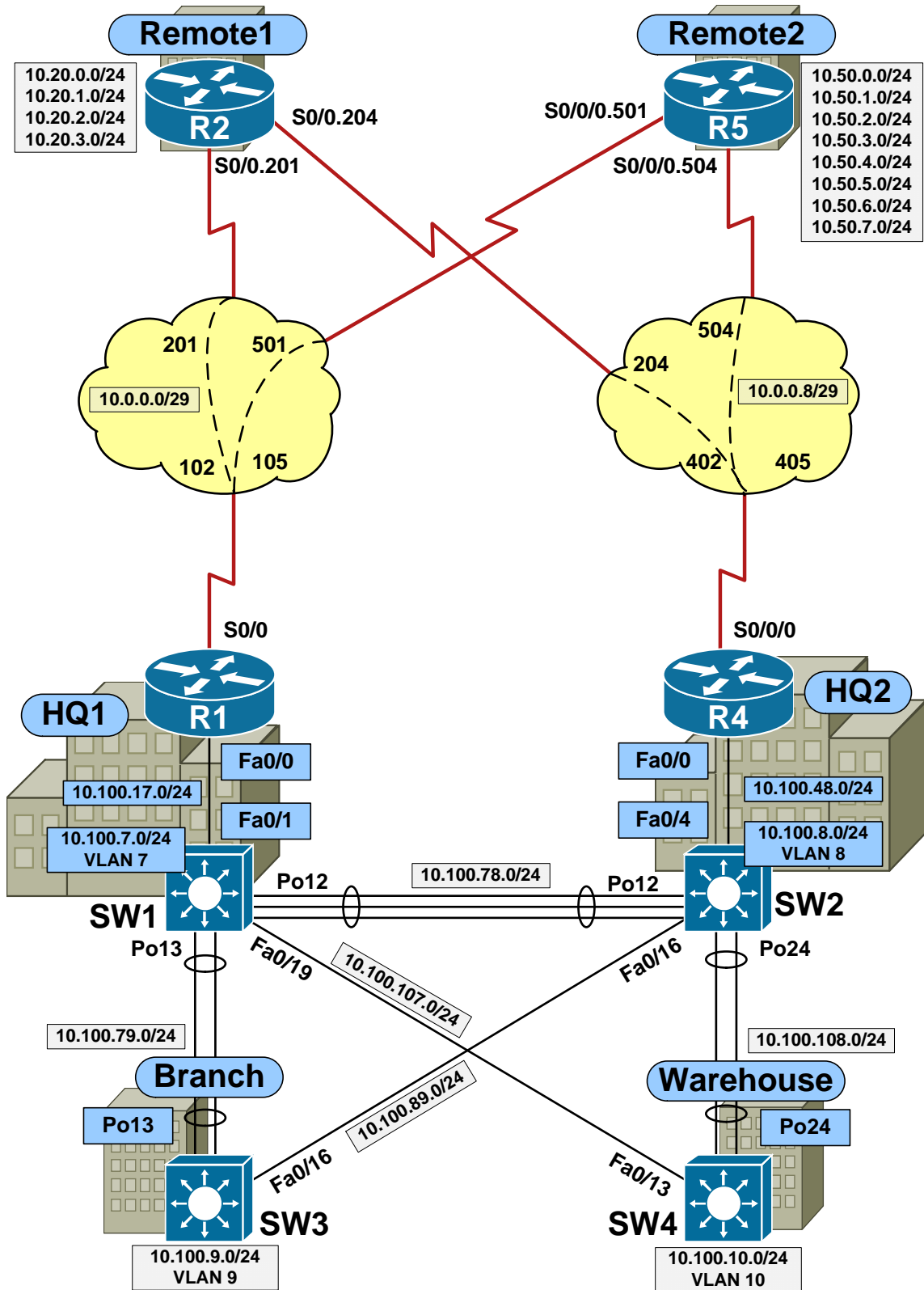

 **Note**

Prior to starting this section load the *BSCI EIGRP Initial Configs* for all devices. Refer to the *DBM Inc. EIGRP Diagram* for device, port, and addressing information.

2.1 Basic EIGRP

- Based on the fact that all routers in the DBM network are Cisco routers, and due to its fast convergence and VLSM support, the design team has decided that EIGRP will be used as the primary IGP.
- Per their request, implement EIGRP in the network using AS number 100 so that it runs on all IP enabled links.
- Once complete, ensure that all devices have IP reachability to all segments in the network, and that offices Remote1 and Remote2 maintain connectivity to all sites in the event that either R1 or R4 goes down.

2.2 EIGRP Security

- To protect the network control plane, the design team has given you the following additional requirements to implement related to EIGRP:
 - EIGRP hello packets should not be sent out host facing interfaces (e.g. non-transit links).
 - All EIGRP adjacencies should be MD5 authenticated with the password DBMI_EIGRP.
 - EIGRP hello packets should be sent as unicast between R1 & SW1 and R4 & SW2 to protect against reconnaissance attacks.

2.3 EIGRP Convergence Optimization

- The design team has informed you that since the Frame Relay network is a Virtual Circuit based technology, a failure can occur in the Service Provider cloud that the routers cannot immediately detect as a link-down event. In order to maintain fast convergence in case of a network failure, they have requested for you to make the following changes:
 - EIGRP routers on the Frame Relay WAN should use a hello time of one second and a hold time of three seconds.
 - R2 should use the circuit to R1 as its primary path, but should pre-calculate the circuit to R4 as a backup path to use in the event of failure.
 - R5 should use the circuit to R4 as its primary path, but should pre-calculate the circuit to R1 as a backup path to use in the event of failure.

2.4 EIGRP Load Balancing

- The Branch office has a 200Mbps EtherChannel link to HQ1, and a 100Mbps FastEthernet link to HQ2, while the Warehouse has a 200Mbps EtherChannel link to HQ2, and a 100Mbps FastEthernet link to HQ1. The HQ offices are interconnected by a 300Mbps EtherChannel link.
- In order to optimize traffic load, the design team has requested that you modify the EIGRP configuration so that both the Branch and Warehouse offices send traffic to the HQ1 VLAN 7 and HQ2 VLAN 8 using both their links to the HQ offices in a ratio directly proportional to their underlying metric values.

2.5 EIGRP Summarization

- The design team has allocated subnet addressing to the Remote1 and Remote2 offices in a way to allow for optimal network summarization.
- They have requested you to configure the devices at these offices to advertise the minimal and optimal number of prefixes up to the HQ offices that are necessary to reach the devices on the remote office LAN segments.

2.6 EIGRP Default Routing

- The design team has chosen R4 to be used as the default exit point out of the network when a longer match route cannot be found. Per their request, configure R4 to advertise a default route to all EIGRP neighbors, regardless of whether its link to ISP2 is up or down.

2.7 EIGRP Stub Routing

- Recently the users at the Remote1 office submitted tickets to the support desk about extremely slow access times to their database applications at the HQ1 and HQ2 offices. After further review, traffic monitoring logs indicated the Frame Relay circuits of R5 at the Remote2 office became 100% saturated at the same time that R4's link to SW2 went down. Based on this the design team has concluded that under certain failure scenarios, the Remote1 and Remote2 offices can be used as transit for Internet related traffic, which is undesirable. Per the request, configure EIGRP stub routing so that the Remote1 and Remote2 offices cannot be used as transit to reach any destinations other than their connected LAN segments.

DBM Inc. OSPF Diagram

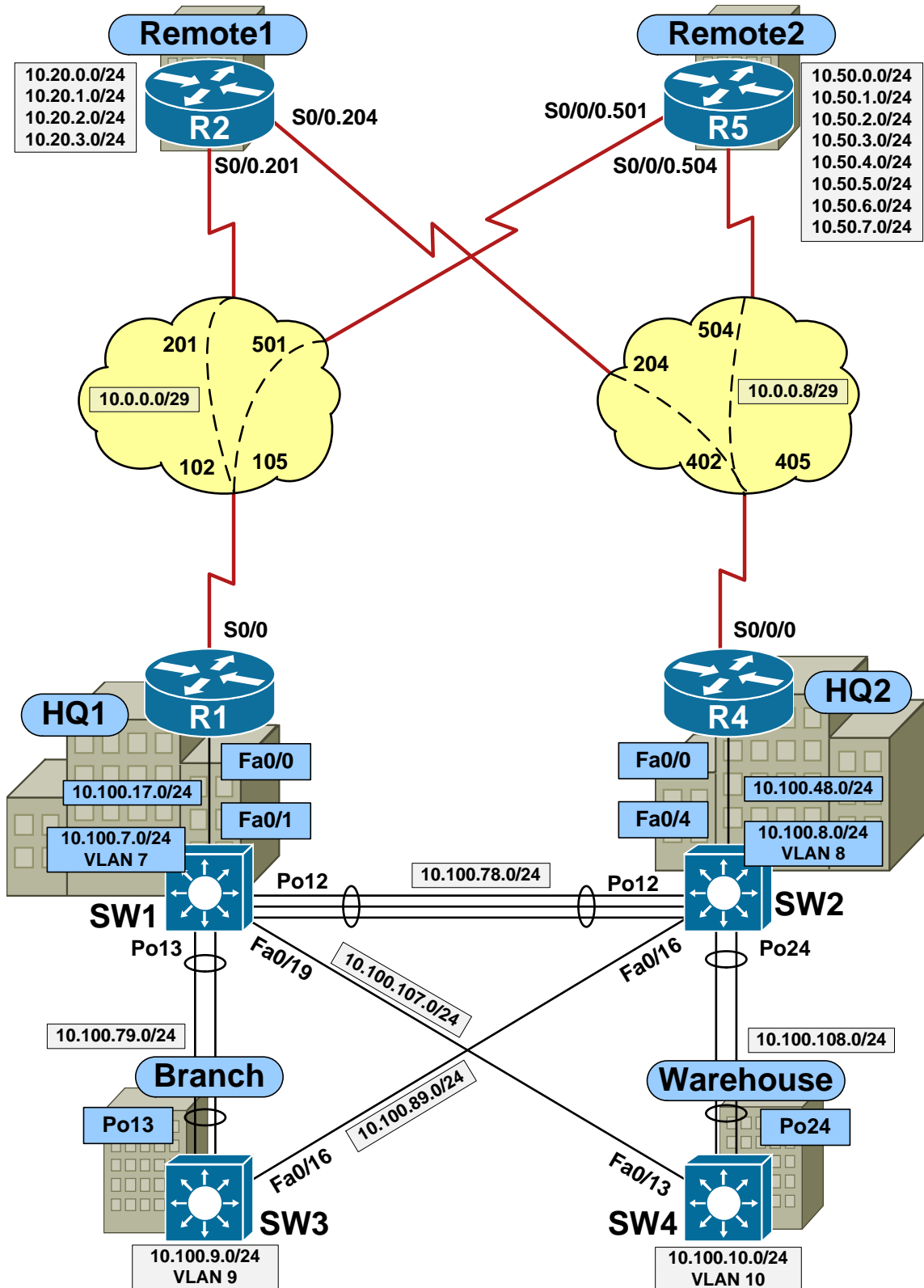

 **Note**

Prior to starting this section load the *BSCI OSPF Initial Configs* for all devices. Refer to the *DBM Inc. OSPF Diagram* for device, port, and addressing information.

3.1 Single Area OSPF

- Due to its large scalability and open source nature, the design team has decided that OSPF will be used as the primary IGP for the DBM network. Per their request, implement OSPF in the network based on the following requirements
 - All devices should use process-id 100
 - All IP enabled links should be in OSPF area 0
 - The Frame Relay WAN links should use OSPF network type non-broadcast, with R1 and R4 as the Designated Routers (DRs)
- Once complete, ensure that all devices have IP reachability to all segments in the network.

3.2 Multi-Area OSPF

- Although the initial OSPF implementation has been successful, network monitoring has shown that minor network changes in the remote offices have been causing SPF to run on all other devices in the network, which in turn causes a spike in CPU utilization. To limit the impact of SPF recalculation, the design team has provided you with a new multi-area OSPF design requirement for you to implement.
- To accomplish this, modify the OSPF configuration per the following requirements:
 - Area 0 should continue to run on the link between R1 and SW1 in HQ1, the link between R4 and SW2 in HQ2, the link between SW1 and SW2 connecting the HQ1 and HQ2 offices, SW1's VLAN 7 interface, and SW2's VLAN 8 interface.
 - Area 789 should now run on all links of SW3 in the Branch office, along with the respective links in HQ1 and HQ2 connecting back to SW3.
 - Area 7810 should now run on all links of SW4 in the Warehouse, along with the respective links in HQ1 and HQ2 connecting back to SW4.
 - Area 1245 should run on HQ1 and HQ2's WAN links to the Remote1 and Remote2 offices, as well as the LAN interfaces of R2 and R5 at the Remote1 and Remote2 offices respectively.
 - The Loopback0 interfaces of R1, R4, SW1, and SW2 should belong to OSPF area 0.
 - The Loopback0 interface of SW3 should belong to OSPF area 789.
 - The Loopback0 interface of SW4 should belong to OSPF area 7810.
 - The Loopback0 interfaces of R2 and R5 should belong to OSPF area 1245.

3.3 OSPF Optimization

- In order to optimize scalability and convergence time, the design team has tasked you with modifying the Frame Relay WAN links to the Remote1 and Remote2 offices as follows:
 - In order to reduce the need for manual neighbor definitions, use the OSPF network type point-to-multipoint
 - In order to optimize convergence if a Frame Relay PVC goes down, use OSPF Fast Hellos with a hello interval of 200ms and a dead interval of 1 second
- Furthermore, in order to reduce unnecessary LSA Type-2 advertisements, they have requested that all point-to-point Ethernet links in the HQ1, HQ2, Branch, and Warehouse offices use OSPF network type point-to-point.

3.4 OSPF Security

- To protect the network control plane, the design team has given you the following additional requirements to implement related to OSPF:
 - OSPF hello packets should not be sent out host facing interfaces (e.g. non-transit links).
 - OSPF adjacencies across the Frame Relay WAN should be authenticated with the clear text password DBMIPASS
 - All other OSPF adjacencies should be authenticated with an MD5 hash of the password DBMIMD5

3.5 OSPF Redundancy

- Recently a trouble ticket was submitted in which users in the HQ1 and HQ2 offices were complaining that they were unable to access resources at each others offices, but were still able to access other offices such as the Warehouse. After further investigation it was found that the links between the HQ1 and HQ2 offices were accidentally cut due to construction in the area. Although there was still an alternate path between HQ1 and HQ2 through other offices, the design team informed you that these paths cannot be used based on the Area 0 intra-area routing requirement of the OSPF database.
- To prevent this problem from occurring again in the future, they have requested that you configure an OSPF Virtual Link so that if the links between SW1 and SW2 go down, traffic between their offices is rerouted through the Warehouse.

3.6 OSPF Path Selection

- Recently trouble tickets have been appearing from users in the Remote1 and Remote2 offices in which they are complaining that response time from a videoconferencing application is very bad. After further investigation with a packet analyzer, it was found that the application is dropping a large amount of traffic due to out of order packets. The design team has informed you that this is due to the fact that R2 and R5 at the Remote1 and Remote2 offices are doing equal cost load balancing, which the application can not deal with.
- To resolve this problem they have requested for you to modify the OSPF path selection so that R2 uses the Frame Relay PVC to R1 as its primary link, and the PVC to R4 as a backup, while R5 uses the Frame Relay PVC to R4 as its primary link, and the PVC to R1 as a backup.

3.7 OSPF Summarization

- The design team has allocated subnet addressing to the Remote1 and Remote2 offices in a way to allow for optimal network summarization, however, they have informed you that OSPF summarization can only occur on an inter-area or external boundary.
- They have requested for you to configure OSPF summarization as follows:
 - R1 and R4 should summarize R2's networks that start with 10.20.x.x as they are advertised into area 0
 - R5 should redistribute its connected LAN segments, and summarize them as they are advertised as external routes into area 1245

3.8 OSPF Stub Areas

- After further resource monitoring, the design team has decided that the OSPF database needs further optimization. They have informed you that the Branch office should only learn default routes to the HQ1 and HQ2 office, but prefer to use HQ1 as its exit point. Furthermore both the Remote1 and Remote2 offices should use only default routes out to HQ1 and HW2 to reach any of the networks beyond the Frame Relay WAN.
- To accomplish this they have requested for you to do the following:
 - Configure OSPF area 789 as a Totally Stubby Area
 - SW1 should advertise a default route into area 789 with a cost of 100, and SW2 should advertised a default route with a cost of 200
 - Configure OSPF area 1245 as a Not-So-Totally-Stubby Area (Totally Stubby NSSA)

DBM Inc. IS-IS Diagram

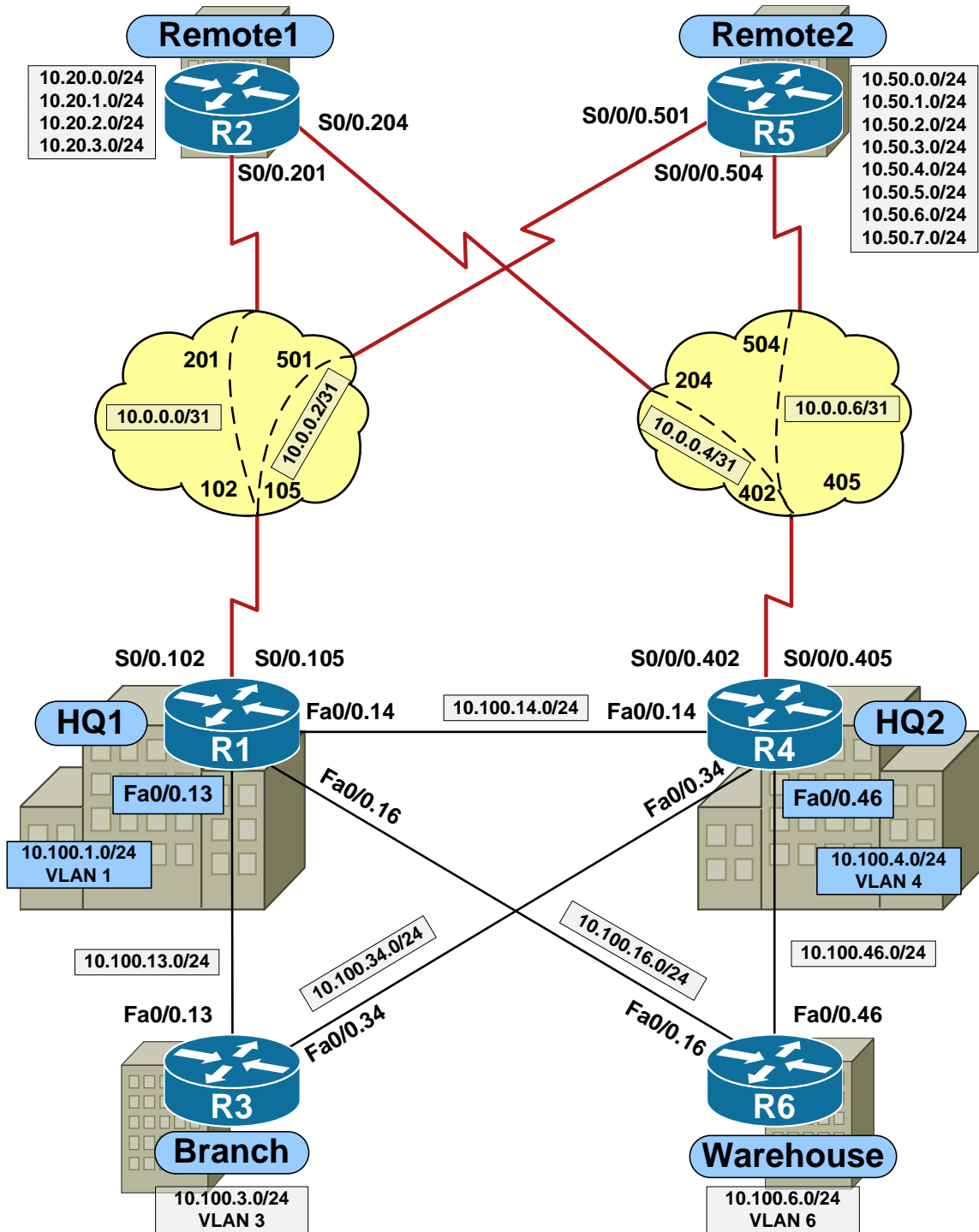

 **Note**

Prior to starting this section load the *BSCI IS-IS Initial Configs* for all devices. Refer to the *DBM Inc. IS-IS Diagram* for device, port, and addressing information.

4.1 Level-2 IS-IS

- Due to its large scalability, simple configuration, and open source nature, the design team has decided that IS-IS will be used as the primary IGP for the DBM network. Per their request, implement Level-2 IS-IS between the HQ1, HQ2, Branch, and Warehouse offices as follows:
 - All devices should use process-id 100
 - R1 should use the NET address 49.0014.0000.0000.0001.00
 - R3 should use the NET address 49.0003.0000.0000.0003.00
 - R4 should use the NET address 49.0014.0000.0000.0004.00
 - R6 should use the NET address 49.0006.0000.0000.0006.00
 - R1 & R4 should be L1/L2 routers
 - R3 & R6 should be L2 only routers
 - Enable IS-IS Level-2 on the links connecting these routers
- The design team has also requested that the Loopback0 interfaces and addition LAN interfaces of these routers be advertised into the IS-IS Level-2 network, but that the **passive-interface** feature be used so that hello packets are not sent out the links.

4.2 Level-1 IS-IS

- The design team has informed you that since the Remote1 and Remote2 offices only have the Frame Relay WAN links to reach the rest of the network, this portion of the network will use IS-IS Level-1 routing to reduce the amount of prefixes the routers at these offices need to receive. They have requested that you configure the network as follows:
 - R2 and R5 should use process-id 100
 - R2 should use the NET address 49.0014.0000.0000.0002.00
 - R5 should use the NET address 49.0014.0000.0000.0005.00
 - R2 & R5 should be Level-1 only routers
 - Enable IS-IS Level-1 on the WAN links connecting R1, R2, R4, and R5
 - Advertise the Loopback0 interfaces of R2 & R5, and the additional LAN interfaces of R2 into IS-IS using the `passive-interface` command
- Once complete, ensure that all devices have IP reachability to all advertised segments in the network.

4.3 IS-IS Optimization

- In order to optimize convergence time, the design team has requested that the IS-IS hello-interval be lowered to 1 second with a hold-time of 3 seconds for neighbor adjacencies over the WAN links.
- Furthermore, in order to reduce unnecessary DIS elections, they have requested that all point-to-point Ethernet links in the HQ1, HQ2, Branch, and Warehouse offices use IS-IS network type point-to-point.
- Configure the network to reflect their requests.

4.4 IS-IS Security

- To protect the network control plane, the design team has requested that all IS-IS adjacencies be authenticated with an MD5 hash of the password DBMIMD5. Configure the network to reflect this request.

4.5 IS-IS Path Selection

- The design team has informed you that monitoring of traffic patterns has indicated that manual intervention is needed to optimize traffic flows. Specifically, they have requested that you modify IS-IS route leaking and cost calculation to accomplish the following:
 - Traffic from the Remote1 and Remote2 offices going to the network 10.100.3.0/24 should always use the WAN link to R1 unless it is down
 - Traffic from the Remote1 and Remote2 offices going to the network 10.100.6.0/24 should always use the WAN link to R4 unless it is down
 - R2 should prefer to use the default route to R1 to reach the rest of the Level-2 domain
 - R5 should prefer to use the default route to R4 to reach the rest of the Level-2 domain
- Configure the network to reflect their request.

4.6 IS-IS Summarization

- The design team has informed you that the additional LAN interface of R5 are being used as a placeholder for networks that are being migrated from another routing protocol. As a temporary solution, they have asked you to advertise these networks into IS-IS through redistribution.
- Furthermore, they have allocated subnet addressing to the Remote1 and Remote2 offices in a way to allow for optimal network summarization, however, they have informed you that IS-IS summarization can only occur on an inter-domain or external boundary. They have requested for you to configure IS-IS summarization as follows:
 - R1 and R4 should summarize R2's networks that start with 10.20.x.x as they are advertised into Level-2
 - R5 should summarize its LAN segments as they are advertised as external routes into Level-1

DBM Inc. BGP Diagram

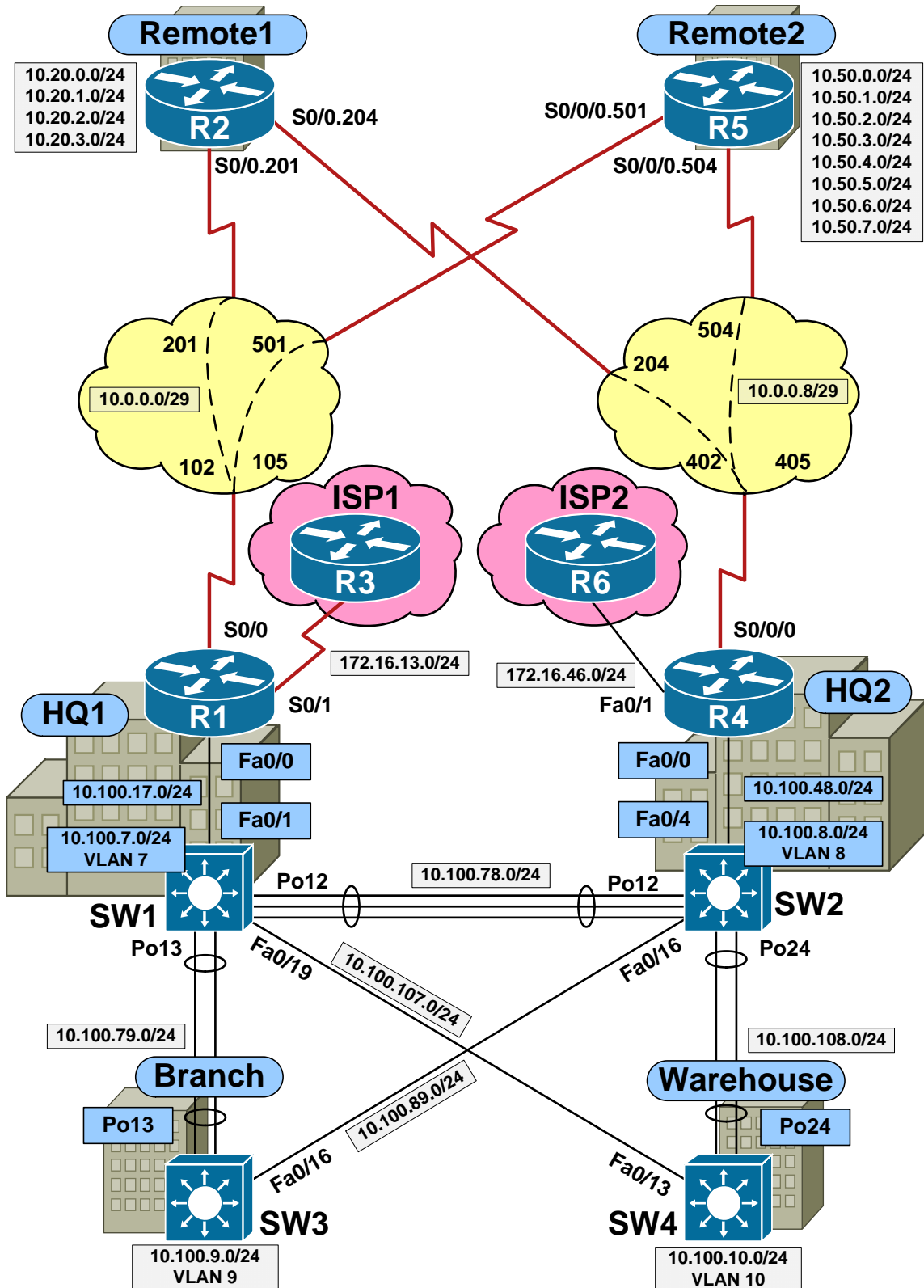

 **Note**

Prior to starting this section load the *BSCI BGP Initial Configs* for all devices. Refer to the *DBM Inc. BGP Diagram* for device, port, and addressing information.

The new DBMI network design includes access to Internet via redundant links to multiple ISPs. Specifically, R1 connects to ISP1 (R3) via a Serial link at the HQ1 office, while R4 connects to ISP2 (R6) via a FastEthernet link at the HQ2 office. Since the connection to ISP2 is via a higher speed link, the network design requires the majority of traffic to transit through HQ2, while the HQ1 office be primarily used as a backup. To ensure proper routing of the traffic, DBMI has been assigned the public ASN 100, and the peering agreements with ISP1 and ISP2 dictate that BGP should be used for network advertisements.

To limit the resource impact of running BGP, only R1 & SW1 at the HQ1 office, and R4 & SW2 at the HQ2 office will be running BGP, while the rest of the network will gain access to the Internet primarily by using default routing to the HQ offices. Configure the network per the design teams below specifications in order to gain reachability to the Internet, and provide redundancy for the network. Note that ISP1 (R3) and ISP2 (R6) are preconfigured for these tasks, and require no modification to accomplish the network design goals. For reachability (PING) testing to the networks learned from ISP1 or ISP2, use the first host address of the subnet.

5.1 iBGP Peerings

- The first step the design team has requested for you to configure in the BGP implementation is the establishment of iBGP peerings between the devices in the HQ1 and HQ2 offices. Specifically they have requested that the following occurs:
 - R1, R4, SW1, and SW2 should form a full mesh of BGP peerings
 - The Loopback0 interfaces should be used as the source and destinations of the peerings to provide for additional redundancy
 - To protect the network control plane, the password DBMIBGP should be used to perform MD5 authentication of the sessions.

5.2 EBGP Peerings

- Next, they have requested that the EBGP peerings to ISP1 and ISP2 be established per the negotiated peering agreements. Specifically the peering agreements are as follows:
 - ISP1 uses the BGP ASN 300, is expecting the peering to use the directly connected link between R1 & R3, and requires authentication using the password ISP1BGP
 - ISP2 uses the BGP ASN 600, is expecting the peering to use the directly connected link between R4 & R6, requires authentication using the password ISP2BGP, and uses high speed hello timers of 1 second and a hold time of 3 seconds
- Since the transit links to ISP1 and ISP2 are not part of your IGP domain, the design team has requested that any required next-hop modification be performed on the border routers R1 & R4 in order to access networks on the Internet.

5.3 BGP NLRI Advertisements

- Internet access is required for hosts on the VLAN 7, 8, 9, & 10 segments, along with hosts on the LAN segments of R2 (10.20.x.x) and R5 (10.50.x.x) at the Remote1 and Remote2 offices respectively. Since the design team has specified that Internet traffic should not be sent to the transit links of the network, e.g. the Frame Relay WAN links, these networks will not be part of the AS 100 advertisements.
- Per their request, configure the border routers R1 and R4 to advertise the required networks into BGP.

5.4 BGP Aggregation

- Both ISP1 and ISP2's BGP routing policies require that the maximum possible aggregation be performed on any networks their customers are advertising to them. To comply with this, the design team has requested for you to perform optimal summarization on R1 and R4 in such a way that they advertise the minimum networks necessary to the ISPs, but at the same time do not advertise reachability for any subnets that are not actually allocated to the DBMI network.

5.5 Outbound BGP Path Selection

- Traffic monitoring has indicated that R1's link to ISP1 is being used to route to a large amount of destinations on the Internet. Since R4's link to ISP2 is a much higher speed interface, the design team has requested for you to modify R4's BGP Bestpath Selection configuration so that all traffic leaving the DBMI network is sent towards ISP2.
- Ensure that this traffic can be rerouted to ISP1 in the event that the link between R4 and R6 is down.

5.6 Inbound BGP Path Selection

- After modifying path selection on R4, traffic monitoring has shown that although traffic leaves the network via the ISP2 peering, some return traffic still comes back through the peering to ISP1. To resolve this the design team has requested for you to modify the attributes on the routes being advertised to ISP1 and ISP2 so that all return traffic comes back through ISP2. Additionally they have informed you that since ISP1 and ISP2 do not exchange MED values, the preferred attribute to modify would be the AS-Path.

DBM Inc. Multicast Diagram

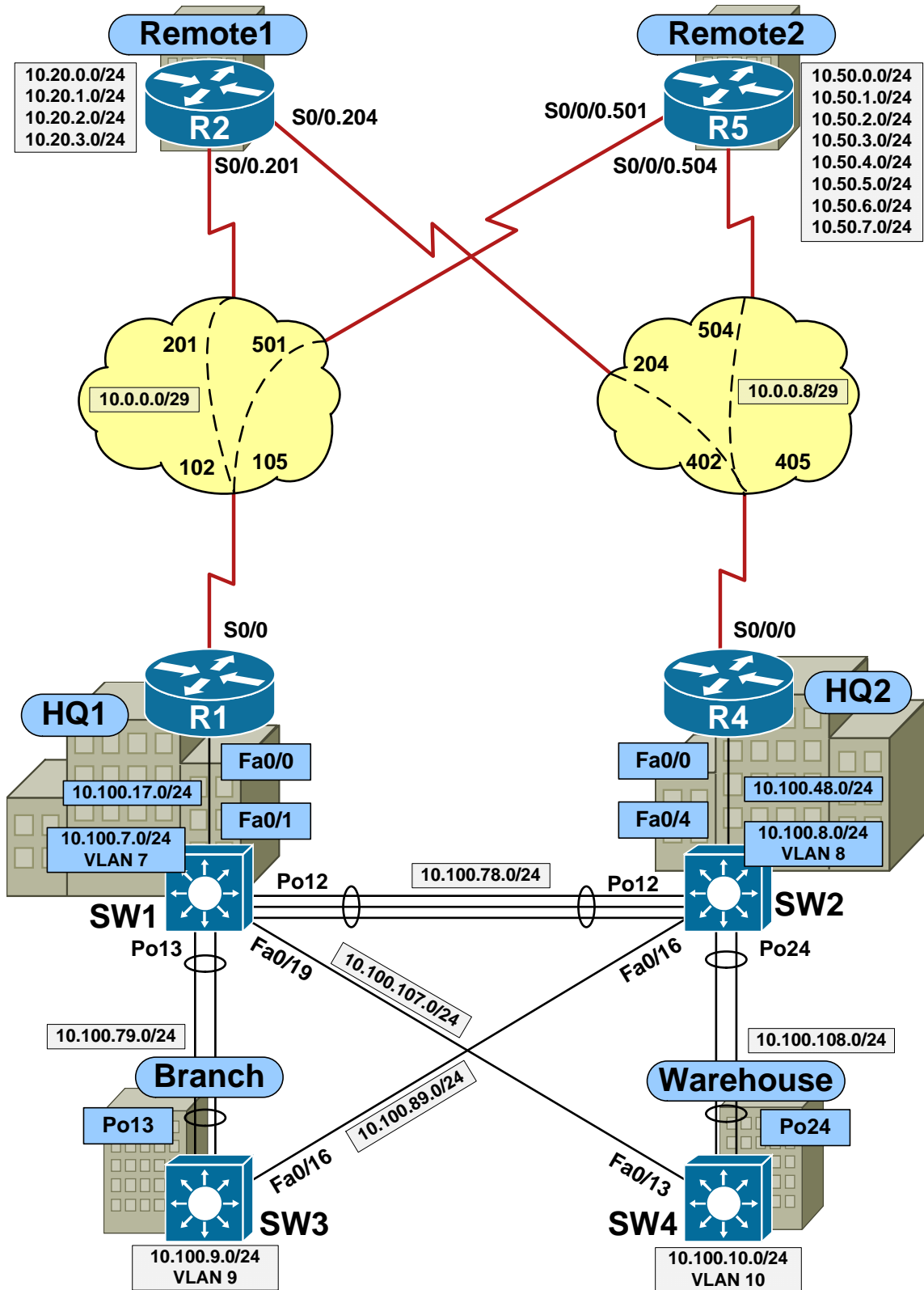

 **Note**

Prior to starting this section load the *BSCI Multicast Initial Configs* for all devices. Refer to the *DBM Inc. Multicast Diagram* for device, port, and addressing information.

6.1 PIM

- Part of the new network design for DBM Inc. includes a streaming video application that uses IP multicast packets for transport. During the first phase of this implementation, the source of the video streams will be located on the VLAN 7 subnet in the HQ1 office. To accommodate this application, the design team has requested that you configure IP multicast in the network per the following specifications:
 - Use PIM Sparse-Dense mode on all IP enabled interfaces in the network
 - R1's Loopback0 address should be statically configured as the Rendezvous Point (RP) for the multicast domain

6.2 Multicast Testing

- Prior to final deployment of the video application, the design team has requested that you perform the following testing to verify that the multicast domain is functional:
 - Configure R2's LAN interface connected to the 10.20.0.0/24 subnet to join the multicast group 224.1.2.3
 - Test proper multicast transit by pinging the group address 224.1.2.3 from SW1 while using the source address 10.100.7.7

DBM Inc. IPv6 Diagram

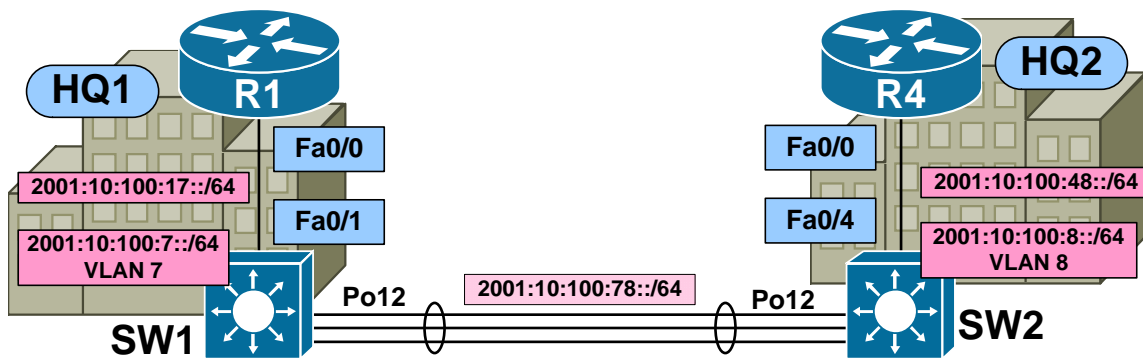

 **Note**

Prior to starting this section load the *BSCI IPv6 Initial Configs* for all devices. Refer to the *DBM Inc. IPv6 Diagram* for device, port, and addressing information.

7.1 IPv6 Addressing

- In order to plan for future migration, the design team has informed you that a test deployment of IPv6 will be implemented between the HQ1 and HQ2 offices. They have requested that you configure IPv6 addressing on the devices in these offices per the below specification:
 - R1
 - Fa0/0 – 2001:10:100:17::1/64
 - Lo0 – 2001:10:255:255::1/128
 - R4
 - Fa0/0 – 2001:10:100:48::4/64
 - Lo0 – 2001:10:255:255::4/128
 - SW1
 - Fa0/1 – 2001:10:100:17::7/64
 - Po12 – 2001:10:100:78::7/64
 - VLAN 7 – 2001:10:100:7::7/64
 - Lo0 – 2001:10:255:255::7/128
 - SW2
 - Fa0/4 – 2001:10:100:48::8/64
 - Po12 – 2001:10:100:78::8/64
 - VLAN 8 – 2001:10:100:8::8/64
 - Lo0 – 2001:10:255:255::8/128

7.2 IPv6 OSPFv3 Routing

- The design team has chosen OSPFv3 to be used for dynamic IPv6 routing due to its open source nature. They have requested that you implement OSPFv3 between the devices in the HQ1 and HQ2 offices as follows:
 - Use process-id 100
 - All IPv6 enabled links should run OSPF area 0
- Once complete, ensure that these four devices have full IPv6 connectivity to each other.

BSCI Solutions

2.1 Basic EIGRP

Configuration

```
R1#
interface Serial0/0
  no ip split-horizon eigrp 100
!
router eigrp 100
  network 10.0.0.0
```

```
R2#
router eigrp 100
  network 10.0.0.0
```

```
R4#
interface Serial0/0/0
  no ip split-horizon eigrp 100
!
router eigrp 100
  network 10.0.0.0
```

```
R5#
router eigrp 100
  network 10.0.0.0
```

```
SW1#
ip routing
!
router eigrp 100
  network 10.0.0.0
```

```
SW2#
ip routing
!
router eigrp 100
  network 10.0.0.0
```

```
SW3#
ip routing
!
router eigrp 100
  network 10.0.0.0
```

```
SW4#
ip routing
!
router eigrp 100
  network 10.0.0.0
```

Verification

R1#show ip eigrp neighbors

IP-EIGRP neighbors for process 100

H	Address	Interface	Hold (sec)	Uptime	SRTT (ms)	RTO	Q Cnt	Seq Num
2	10.100.17.7	Fa0/0	13	00:08:46	57	342	0	66
1	10.0.0.2	Se0/0	12	00:08:46	83	498	0	51
0	10.0.0.3	Se0/0	12	00:08:46	48	288	0	46

R1#show ip route

Codes: C - connected, S - static, R - RIP, M - mobile, B - BGP

D - EIGRP, EX - EIGRP external, O - OSPF, IA - OSPF inter area

N1 - OSPF NSSA external type 1, N2 - OSPF NSSA external type 2

E1 - OSPF external type 1, E2 - OSPF external type 2

i - IS-IS, su - IS-IS summary, L1 - IS-IS level-1, L2 - IS-IS level-2

ia - IS-IS inter area, * - candidate default, U - per-user static route

o - ODR, P - periodic downloaded static route

Gateway of last resort is not set

```

10.0.0.0/8 is variably subnetted, 33 subnets, 3 masks
D    10.255.255.10/32
      [90/161280] via 10.100.17.7, 00:07:32, FastEthernet0/0
D    10.255.255.8/32 [90/158720] via 10.100.17.7, 00:07:37, FastEthernet0/0
D    10.100.108.0/24 [90/33280] via 10.100.17.7, 00:07:37, FastEthernet0/0
D    10.0.0.8/29 [90/2177536] via 10.100.17.7, 00:05:06, FastEthernet0/0
D    10.255.255.9/32 [90/158720] via 10.100.17.7, 00:07:35, FastEthernet0/0
D    10.100.107.0/24 [90/30720] via 10.100.17.7, 00:07:42, FastEthernet0/0
D    10.255.255.2/32 [90/2297856] via 10.0.0.2, 00:08:54, Serial0/0
C    10.0.0.0/29 is directly connected, Serial0/0
C    10.255.255.1/32 is directly connected, Loopback0
D    10.255.255.7/32 [90/156160] via 10.100.17.7, 00:07:42, FastEthernet0/0
D    10.255.255.4/32 [90/161280] via 10.100.17.7, 00:08:53, FastEthernet0/0
D    10.255.255.5/32 [90/2297856] via 10.0.0.3, 00:08:51, Serial0/0
D    10.20.2.0/24 [90/2172416] via 10.0.0.2, 00:08:54, Serial0/0
D    10.20.3.0/24 [90/2172416] via 10.0.0.2, 00:08:54, Serial0/0
D    10.20.0.0/24 [90/2172416] via 10.0.0.2, 00:08:54, Serial0/0
D    10.20.1.0/24 [90/2172416] via 10.0.0.2, 00:08:54, Serial0/0
D    10.100.78.0/24 [90/30720] via 10.100.17.7, 00:07:42, FastEthernet0/0
D    10.100.79.0/24 [90/30720] via 10.100.17.7, 00:07:42, FastEthernet0/0
D    10.100.89.0/24 [90/33280] via 10.100.17.7, 00:07:38, FastEthernet0/0
D    10.50.0.0/24 [90/2172416] via 10.0.0.3, 00:08:52, Serial0/0
D    10.50.1.0/24 [90/2172416] via 10.0.0.3, 00:08:52, Serial0/0
D    10.50.2.0/24 [90/2172416] via 10.0.0.3, 00:08:52, Serial0/0
D    10.50.3.0/24 [90/2172416] via 10.0.0.3, 00:08:52, Serial0/0
D    10.50.4.0/24 [90/2172416] via 10.0.0.3, 00:08:52, Serial0/0
D    10.50.5.0/24 [90/2172416] via 10.0.0.3, 00:08:52, Serial0/0
D    10.50.6.0/24 [90/2172416] via 10.0.0.3, 00:08:52, Serial0/0
D    10.50.7.0/24 [90/2172416] via 10.0.0.3, 00:08:52, Serial0/0
D    10.100.48.0/24 [90/33280] via 10.100.17.7, 00:07:40, FastEthernet0/0
D    10.100.10.0/24 [90/33536] via 10.100.17.7, 00:07:34, FastEthernet0/0
D    10.100.8.0/24 [90/30976] via 10.100.17.7, 00:07:40, FastEthernet0/0
D    10.100.9.0/24 [90/30976] via 10.100.17.7, 00:07:37, FastEthernet0/0
D    10.100.7.0/24 [90/28416] via 10.100.17.7, 00:07:43, FastEthernet0/0
C    10.100.17.0/24 is directly connected, FastEthernet0/0

```

R1#show ip eigrp topology

IP-EIGRP Topology Table for AS(100)/ID(10.255.255.1)

Codes: P - Passive, A - Active, U - Update, Q - Query, R - Reply,
r - reply Status, s - sia Status

```
P 10.255.255.10/32, 1 successors, FD is 158720
    via 10.100.17.7 (161280/145920), FastEthernet0/0
P 10.0.0.8/29, 1 successors, FD is 2177536
    via 10.100.17.7 (2177536/2174976), FastEthernet0/0
    via 10.0.0.3 (2681856/2169856), Serial0/0
    via 10.0.0.2 (2681856/2169856), Serial0/0
P 10.255.255.8/32, 1 successors, FD is 158720
    via 10.100.17.7 (158720/139008), FastEthernet0/0
P 10.100.108.0/24, 1 successors, FD is 33280
    via 10.100.17.7 (33280/17920), FastEthernet0/0
P 10.255.255.9/32, 1 successors, FD is 158720
    via 10.100.17.7 (158720/143360), FastEthernet0/0
P 10.100.107.0/24, 1 successors, FD is 30720
    via 10.100.17.7 (30720/28160), FastEthernet0/0
P 10.255.255.2/32, 1 successors, FD is 2297856
    via 10.0.0.2 (2297856/128256), Serial0/0
P 10.0.0.0/29, 1 successors, FD is 2169856
    via Connected, Serial0/0
P 10.255.255.1/32, 1 successors, FD is 128256
    via Connected, Loopback0
P 10.255.255.7/32, 1 successors, FD is 156160
    via 10.100.17.7 (156160/128256), FastEthernet0/0
P 10.255.255.4/32, 1 successors, FD is 161280
    via 10.100.17.7 (161280/158720), FastEthernet0/0
P 10.255.255.5/32, 1 successors, FD is 2297856
    via 10.0.0.3 (2297856/128256), Serial0/0
P 10.20.2.0/24, 1 successors, FD is 2172416
    via 10.0.0.2 (2172416/28160), Serial0/0
P 10.20.3.0/24, 1 successors, FD is 2172416
    via 10.0.0.2 (2172416/28160), Serial0/0
P 10.20.0.0/24, 1 successors, FD is 2172416
    via 10.0.0.2 (2172416/28160), Serial0/0
P 10.20.1.0/24, 1 successors, FD is 2172416
    via 10.0.0.2 (2172416/28160), Serial0/0
P 10.100.78.0/24, 1 successors, FD is 30720
    via 10.100.17.7 (30720/11008), FastEthernet0/0
P 10.100.79.0/24, 1 successors, FD is 30720
    via 10.100.17.7 (30720/15360), FastEthernet0/0
P 10.100.89.0/24, 1 successors, FD is 33280
    via 10.100.17.7 (33280/30720), FastEthernet0/0
P 10.50.0.0/24, 1 successors, FD is 2172416
    via 10.0.0.3 (2172416/28160), Serial0/0
P 10.50.1.0/24, 1 successors, FD is 2172416
    via 10.0.0.3 (2172416/28160), Serial0/0
P 10.50.2.0/24, 1 successors, FD is 2172416
    via 10.0.0.3 (2172416/28160), Serial0/0
P 10.50.3.0/24, 1 successors, FD is 2172416
    via 10.0.0.3 (2172416/28160), Serial0/0
P 10.50.4.0/24, 1 successors, FD is 2172416
    via 10.0.0.3 (2172416/28160), Serial0/0
P 10.50.5.0/24, 1 successors, FD is 2172416
    via 10.0.0.3 (2172416/28160), Serial0/0
P 10.50.6.0/24, 1 successors, FD is 2172416
    via 10.0.0.3 (2172416/28160), Serial0/0
P 10.50.7.0/24, 1 successors, FD is 2172416
    via 10.0.0.3 (2172416/28160), Serial0/0
P 10.100.48.0/24, 1 successors, FD is 33280
```

```
    via 10.100.17.7 (33280/30720), FastEthernet0/0
P 10.100.10.0/24, 1 successors, FD is 30976
    via 10.100.17.7 (33536/18176), FastEthernet0/0
P 10.100.8.0/24, 1 successors, FD is 30976
    via 10.100.17.7 (30976/11264), FastEthernet0/0
P 10.100.9.0/24, 1 successors, FD is 30976
    via 10.100.17.7 (30976/15616), FastEthernet0/0
P 10.100.7.0/24, 1 successors, FD is 28416
    via 10.100.17.7 (28416/2816), FastEthernet0/0
P 10.100.17.0/24, 1 successors, FD is 28160
    via Connected, FastEthernet0/0
```

2.2 EIGRP Security

Configuration

```
R1#
key chain EIGRP
  key 1
    key-string DBMI_EIGRP
!
interface FastEthernet0/0
  ip authentication mode eigrp 100 md5
  ip authentication key-chain eigrp 100 EIGRP
!
interface Serial0/0
  ip authentication mode eigrp 100 md5
  ip authentication key-chain eigrp 100 EIGRP
!
router eigrp 100
  neighbor 10.100.17.7 FastEthernet0/0

R2#
key chain EIGRP
  key 1
    key-string DBMI_EIGRP
!
interface Serial0/0.201 point-to-point
  ip authentication mode eigrp 100 md5
  ip authentication key-chain eigrp 100 EIGRP
!
interface Serial0/0.204 point-to-point
  ip authentication mode eigrp 100 md5
  ip authentication key-chain eigrp 100 EIGRP
!
router eigrp 100
  passive-interface default
  no passive-interface Serial0/0.201
  no passive-interface Serial0/0.204

R4#
key chain EIGRP
  key 1
    key-string DBMI_EIGRP
!
interface FastEthernet0/0
  ip authentication mode eigrp 100 md5
  ip authentication key-chain eigrp 100 EIGRP
!
interface Serial0/0/0
  ip authentication mode eigrp 100 md5
  ip authentication key-chain eigrp 100 EIGRP
!
router eigrp 100
  neighbor 10.100.48.8 FastEthernet0/0
```

```
R5#
key chain EIGRP
  key 1
    key-string DBMI_EIGRP
!
interface Serial0/0/0.501 point-to-point
  ip authentication mode eigrp 100 md5
  ip authentication key-chain eigrp 100 EIGRP
!
interface Serial0/0/0.504 point-to-point
  ip authentication mode eigrp 100 md5
  ip authentication key-chain eigrp 100 EIGRP
!
router eigrp 100
  passive-interface default
  no passive-interface Serial0/0/0.501
  no passive-interface Serial0/0/0.504

SW1#
key chain EIGRP
  key 1
    key-string DBMI_EIGRP
!
interface Port-channel12
  ip authentication mode eigrp 100 md5
  ip authentication key-chain eigrp 100 EIGRP
!
interface Port-channel13
  ip authentication mode eigrp 100 md5
  ip authentication key-chain eigrp 100 EIGRP
!
interface FastEthernet0/1
  ip authentication mode eigrp 100 md5
  ip authentication key-chain eigrp 100 EIGRP
!
interface FastEthernet0/19
  ip authentication mode eigrp 100 md5
  ip authentication key-chain eigrp 100 EIGRP
!
router eigrp 100
  passive-interface Vlan7
  neighbor 10.100.17.1 FastEthernet0/1
```

```
SW2#
key chain EIGRP
  key 1
    key-string DBMI_EIGRP
  !
interface Port-channel12
  ip authentication mode eigrp 100 md5
  ip authentication key-chain eigrp 100 EIGRP
  !
interface Port-channel24
  ip authentication mode eigrp 100 md5
  ip authentication key-chain eigrp 100 EIGRP
  !
interface FastEthernet0/4
  ip authentication mode eigrp 100 md5
  ip authentication key-chain eigrp 100 EIGRP
  !
interface FastEthernet0/16
  ip authentication mode eigrp 100 md5
  ip authentication key-chain eigrp 100 EIGRP
  !
router eigrp 100
  passive-interface Vlan8
  neighbor 10.100.48.4 FastEthernet0/4
```

```
SW3#
key chain EIGRP
  key 1
    key-string DBMI_EIGRP
  !
interface Port-channel13
  ip authentication mode eigrp 100 md5
  ip authentication key-chain eigrp 100 EIGRP
  !
interface FastEthernet0/16
  ip authentication mode eigrp 100 md5
  ip authentication key-chain eigrp 100 EIGRP
  !
router eigrp 100
  passive-interface Vlan9
```

```
SW4#
key chain EIGRP
  key 1
    key-string DBMI_EIGRP
  !
interface Port-channel24
  ip authentication mode eigrp 100 md5
  ip authentication key-chain eigrp 100 EIGRP
  !
interface FastEthernet0/13
  ip authentication mode eigrp 100 md5
  ip authentication key-chain eigrp 100 EIGRP
  !
router eigrp 100
  passive-interface Vlan10
```

Verification

R2#show ip protocols

```
Routing Protocol is "eigrp 100"
  Outgoing update filter list for all interfaces is not set
  Incoming update filter list for all interfaces is not set
  Default networks flagged in outgoing updates
  Default networks accepted from incoming updates
  EIGRP metric weight K1=1, K2=0, K3=1, K4=0, K5=0
  EIGRP maximum hopcount 100
  EIGRP maximum metric variance 1
  Redistributing: eigrp 100
  EIGRP NSF-aware route hold timer is 240s
  Automatic network summarization is in effect
  Maximum path: 4
  Routing for Networks:
    10.0.0.0
  Passive Interface(s):
    FastEthernet0/0
    FastEthernet0/0.200
    FastEthernet0/0.201
    FastEthernet0/0.202
    FastEthernet0/0.203
    Serial0/0
    Serial0/1
    Loopback0
    VoIP-Null0
  Routing Information Sources:
    Gateway         Distance      Last Update
    10.0.0.9         90           00:05:05
    10.0.0.1         90           00:05:05
  Distance: internal 90 external 170
```

 **Note**

The below debug output indicates that only unicast hellos are exchanged between R1 and SW1.

R1#debug ip packet

```
IP packet debugging is on
IP: s=10.100.17.1 (local), d=10.100.17.7 (FastEthernet0/0), len 100,
sending
IP: s=10.0.0.3 (Serial0/0), d=224.0.0.10, len 100, rcvd 2
IP: s=10.255.255.1 (local), d=224.0.0.10 (Loopback0), len 60, sending
broad/multicast
IP: s=10.255.255.1 (Loopback0), d=224.0.0.10, len 60, rcvd 2
IP: s=10.0.0.2 (Serial0/0), d=224.0.0.10, len 100, rcvd 2
IP: tableid=0, s=10.100.17.7 (FastEthernet0/0), d=10.100.17.1
(FastEthernet0/0), routed via RIB
IP: s=10.100.17.7 (FastEthernet0/0), d=10.100.17.1 (FastEthernet0/0),
len 100, rcvd 3
IP: s=10.100.17.1 (local), d=10.100.17.7 (FastEthernet0/0), len 100,
sending
IP: s=10.0.0.3 (Serial0/0), d=224.0.0.10, len 100, rcvd 2
IP: s=10.255.255.1 (local), d=224.0.0.10 (Loopback0), len 60, sending
broad/multicast
IP: s=10.255.255.1 (Loopback0), d=224.0.0.10, len 60, rcvd 2
IP: s=10.0.0.2 (Serial0/0), d=224.0.0.10, len 100, rcvd 2
IP: tableid=0, s=10.100.17.7 (FastEthernet0/0), d=10.100.17.1
(FastEthernet0/0), routed via RIB
IP: s=10.100.17.7 (FastEthernet0/0), d=10.100.17.1 (FastEthernet0/0),
len 100, rcvd 3
```

 **Note**

If EIGRP authentication failed, neighbor adjacency would not have occurred.

R1#show ip eigrp neighbors

```
IP-EIGRP neighbors for process 100
H   Address                Interface    Hold Uptime    SRTT    RTO    Q   Seq
                               (sec)          (ms)          Cnt   Num
2   10.100.17.7              Fa0/0       13 00:07:06    3     200    0   291
1   10.0.0.3                 Se0/0       11 00:07:49    65    390    0   152
0   10.0.0.2                 Se0/0       11 00:08:01    71    426    0   146
```

2.3 EIGRP Convergence Optimization

Configuration

```
R1#
interface Serial0/0
 ip hello-interval eigrp 100 1
 ip hold-time eigrp 100 3

R2#
interface Serial0/0.201 point-to-point
 ip hello-interval eigrp 100 1
 ip hold-time eigrp 100 3
!
interface Serial0/0.204 point-to-point
 ip hello-interval eigrp 100 1
 ip hold-time eigrp 100 3
 delay 4000

R4#
interface Serial0/0/0
 ip hello-interval eigrp 100 1
 ip hold-time eigrp 100 3

R5#
interface Serial0/0/0.501 point-to-point
 ip hello-interval eigrp 100 1
 ip hold-time eigrp 100 3
 delay 4000
!
interface Serial0/0/0.504 point-to-point
 ip hello-interval eigrp 100 1
 ip hold-time eigrp 100 3
```

Verification

R2#show ip eigrp neighbors

IP-EIGRP neighbors for process 100

H	Address	Interface	Hold (sec)	Uptime	SRTT (ms)	RTO	Q Cnt	Seq Num
1	10.0.0.1	Se0/0.201	2	00:25:57	101	606	0	305
0	10.0.0.9	Se0/0.204	2	00:33:13	84	504	0	318

Note

Only one successor exists in R2's topology table for each destination, all of which are reachable via R1 (Serial0/0.201). However, a Feasible Successor (backup route) is installed via R4 (Serial0/0.204) since the Advertised Distance is lower than the Feasible Distance.

R2#show ip eigrp topology

IP-EIGRP Topology Table for AS(100)/ID(10.255.255.2)

Codes: P - Passive, A - Active, U - Update, Q - Query, R - Reply,
r - reply Status, s - sia Status

```
P 10.255.255.10/32, 1 successors, FD is 2302976
  via 10.0.0.1 (2305536/161280), Serial0/0.201
  via 10.0.0.9 (2814976/158720), Serial0/0.204
P 10.255.255.8/32, 1 successors, FD is 2302976
  via 10.0.0.1 (2302976/158720), Serial0/0.201
  via 10.0.0.9 (2812416/156160), Serial0/0.204
P 10.100.108.0/24, 1 successors, FD is 2177536
  via 10.0.0.1 (2177536/33280), Serial0/0.201
  via 10.0.0.9 (2686976/30720), Serial0/0.204
P 10.0.0.8/29, 1 successors, FD is 2681856
  via Connected, Serial0/0.204
  via 10.0.0.9 (3193856/2169856), Serial0/0.204
  via 10.0.0.1 (2689536/2177536), Serial0/0.201
P 10.255.255.9/32, 1 successors, FD is 2302976
  via 10.0.0.1 (2302976/158720), Serial0/0.201
  via 10.0.0.9 (2817536/161280), Serial0/0.204
P 10.100.107.0/24, 1 successors, FD is 2174976
  via 10.0.0.1 (2174976/30720), Serial0/0.201
  via 10.0.0.9 (2689536/33280), Serial0/0.204
P 10.255.255.2/32, 1 successors, FD is 128256
  via Connected, Loopback0
P 10.0.0.0/29, 1 successors, FD is 2169856
  via Connected, Serial0/0.201
P 10.255.255.1/32, 1 successors, FD is 2297856
  via 10.0.0.1 (2297856/128256), Serial0/0.201
  via 10.0.0.9 (2817536/161280), Serial0/0.204
<output omitted>
```

All routes in R2's routing table are reachable via R1 only, and not via R4.

```
R2#show ip route eigrp
 10.0.0.0/8 is variably subnetted, 33 subnets, 3 masks
D    10.255.255.10/32 [90/2305536] via 10.0.0.1, 00:02:56, Serial0/0.201
D    10.255.255.8/32 [90/2302976] via 10.0.0.1, 00:02:56, Serial0/0.201
D    10.100.108.0/24 [90/2177536] via 10.0.0.1, 00:02:56, Serial0/0.201
D    10.255.255.9/32 [90/2302976] via 10.0.0.1, 00:02:56, Serial0/0.201
D    10.100.107.0/24 [90/2174976] via 10.0.0.1, 00:02:56, Serial0/0.201
D    10.255.255.1/32 [90/2297856] via 10.0.0.1, 00:02:56, Serial0/0.201
D    10.255.255.7/32 [90/2300416] via 10.0.0.1, 00:02:56, Serial0/0.201
D    10.255.255.4/32 [90/2305536] via 10.0.0.1, 00:02:56, Serial0/0.201
D    10.255.255.5/32 [90/2809856] via 10.0.0.1, 00:22:45, Serial0/0.201
D    10.100.78.0/24 [90/2174976] via 10.0.0.1, 00:02:56, Serial0/0.201
D    10.100.79.0/24 [90/2174976] via 10.0.0.1, 00:02:56, Serial0/0.201
D    10.100.89.0/24 [90/2177536] via 10.0.0.1, 00:02:56, Serial0/0.201
D    10.50.0.0/24 [90/2684416] via 10.0.0.1, 00:22:45, Serial0/0.201
D    10.50.1.0/24 [90/2684416] via 10.0.0.1, 00:22:46, Serial0/0.201
D    10.50.2.0/24 [90/2684416] via 10.0.0.1, 00:22:46, Serial0/0.201
D    10.50.3.0/24 [90/2684416] via 10.0.0.1, 00:22:46, Serial0/0.201
D    10.50.4.0/24 [90/2684416] via 10.0.0.1, 00:22:46, Serial0/0.201
D    10.50.5.0/24 [90/2684416] via 10.0.0.1, 00:22:46, Serial0/0.201
D    10.50.6.0/24 [90/2684416] via 10.0.0.1, 00:22:46, Serial0/0.201
D    10.50.7.0/24 [90/2684416] via 10.0.0.1, 00:22:46, Serial0/0.201
D    10.100.48.0/24 [90/2177536] via 10.0.0.1, 00:02:57, Serial0/0.201
D    10.100.10.0/24 [90/2177792] via 10.0.0.1, 00:02:57, Serial0/0.201
D    10.100.8.0/24 [90/2175232] via 10.0.0.1, 00:02:57, Serial0/0.201
D    10.100.9.0/24 [90/2175232] via 10.0.0.1, 00:02:57, Serial0/0.201
D    10.100.7.0/24 [90/2172672] via 10.0.0.1, 00:02:57, Serial0/0.201
D    10.100.17.0/24 [90/2172416] via 10.0.0.1, 00:02:58, Serial0/0.201
```

Fast convergence occurs on R2 when R1's link to SW1 goes down, since the backup path is already pre-calculated.

```
R2#ping 10.100.10.10 repeat 10000
```

```
Type escape sequence to abort.
Sending 10000, 100-byte ICMP Echos to 10.100.10.10, timeout is 2 seconds:
!!!!!!!!!!!!!!!!!!!!!!!!!!!!!!!!!!!!!!!!!!!!!!!!!!!!!!!!!!!!!!!!!!!!!!!!!!!!
!!!!!!!!!!!!!!!!!!!!!!!!!!!!!!!!!!!!!!!!!!!!!!!!!!!!!!!!!!!!!!!!!!!!!!!!!!!!
```

```
R1#config t
Enter configuration commands, one per line. End with CNTL/Z.
R1(config)#interface Fa0/0
R1(config-if)#shutdown
R1(config-if)#
```

```
R2#
!!!.!!!!!!!!!!!!!!!!!!!!!!!!!!!!!!!!!!!!!!!!!!!!!!!!!!!!!!!!!!!!!!!!!!!!!!!!!!!!
!!!!!!!!!!!!!!!!!!!!!!!!!!!!!!!!!!!!!!!!!!!!!!!!!!!!!!!!!!!!!!!!!!!!!!!!!!!!
Success rate is 99 percent (349/350), round-trip min/avg/max = 56/58/120 ms
```

2.4 EIGRP Load Balancing

Configuration

```
SW3#  
router eigrp 100  
  variance 2
```

```
SW4#  
router eigrp 100  
  variance 2
```

Verification

Note

SW3 routes the prefix 10.100.7.0/24 via Port-Channel13 with a metric of 15616. Since the route via FastEthernet0/16 has an Advertised Distance of 11264, it is a feasible successor, and is candidate for unequal cost load balancing.

```
SW3#show ip eigrp topology 10.100.7.0 255.255.255.0  
EIGRP-IPv4:(100) (AS 100): Topology Default-IP-Routing-Table(0) entry  
for 10.100.7.0/24  
  State is Passive, Query origin flag is 1, 1 Successor(s), FD is 15616  
  Descriptor Blocks:  
    10.100.79.7 (Port-channel13), from 10.100.79.7, Send flag is 0x0  
      Composite metric is (15616/2816), Route is Internal  
      Vector metric:  
        Minimum bandwidth is 200000 Kbit  
        Total delay is 110 microseconds  
        Reliability is 255/255  
        Load is 1/255  
        Minimum MTU is 1500  
        Hop count is 1  
    10.100.89.8 (FastEthernet0/16), from 10.100.89.8, Send flag is 0x0  
      Composite metric is (30976/11264), Route is Internal  
      Vector metric:  
        Minimum bandwidth is 100000 Kbit  
        Total delay is 210 microseconds  
        Reliability is 255/255  
        Load is 1/255  
        Minimum MTU is 1500  
        Hop count is 2
```

With a *variance* value of 2, the Feasible Distance is multiplied by 2. Since this result is greater than the total metric via the Feasible Successor, both can be installed in the routing table. Note that the traffic share is almost exactly in a ratio of 1:2, which is proportional to the metric values of the underlying paths.

```
SW3#show ip route 10.100.7.0
```

```
Routing entry for 10.100.7.0/24
```

```
Known via "eigrp 100", distance 90, metric 15616, type internal
```

```
Redistributing via eigrp 100
```

```
Last update from 10.100.79.7 on Port-channel13, 00:01:57 ago
```

```
Routing Descriptor Blocks:
```

```
* 10.100.89.8, from 10.100.89.8, 00:01:57 ago, via FastEthernet0/16
```

```
Route metric is 30976, traffic share count is 121
```

```
Total delay is 210 microseconds, minimum bandwidth is 100000 Kbit
```

```
Reliability 255/255, minimum MTU 1500 bytes
```

```
Loading 1/255, Hops 2
```

```
10.100.79.7, from 10.100.79.7, 00:01:57 ago, via Port-channel13
```

```
Route metric is 15616, traffic share count is 240
```

```
Total delay is 110 microseconds, minimum bandwidth is 200000 Kbit
```

```
Reliability 255/255, minimum MTU 1500 bytes
```

```
Loading 1/255, Hops 1
```

2.5 EIGRP Summarization

Configuration

```
R2#
interface Serial0/0.201 point-to-point
 ip summary-address eigrp 100 10.20.0.0 255.255.252.0 5
!
interface Serial0/0.204 point-to-point
 ip summary-address eigrp 100 10.20.0.0 255.255.252.0 5

R5#
interface Serial0/0/0.501 point-to-point
 ip summary-address eigrp 100 10.50.0.0 255.255.248.0 5
!
interface Serial0/0/0.504 point-to-point
 ip summary-address eigrp 100 10.50.0.0 255.255.248.0 5
```

Verification

Note

R1 no longer learns the subnet routes to R2 and R5's LAN interfaces, only the summaries.

```
R1#show ip route eigrp
 10.0.0.0/8 is variably subnetted, 23 subnets, 5 masks
D    10.255.255.10/32
     [90/161280] via 10.100.17.7, 00:04:32, FastEthernet0/0
D    10.255.255.8/32 [90/158720] via 10.100.17.7, 00:04:32, FastEthernet0/0
D    10.100.108.0/24 [90/33280] via 10.100.17.7, 00:04:32, FastEthernet0/0
D    10.0.0.8/29 [90/2177536] via 10.100.17.7, 00:04:32, FastEthernet0/0
D    10.255.255.9/32 [90/158720] via 10.100.17.7, 00:04:31, FastEthernet0/0
D    10.100.107.0/24 [90/30720] via 10.100.17.7, 00:04:32, FastEthernet0/0
D    10.255.255.2/32 [90/2297856] via 10.0.0.2, 00:30:07, Serial0/0
D    10.255.255.7/32 [90/156160] via 10.100.17.7, 00:04:32, FastEthernet0/0
D    10.255.255.4/32 [90/161280] via 10.100.17.7, 00:04:32, FastEthernet0/0
D    10.255.255.5/32 [90/2297856] via 10.0.0.3, 00:33:29, Serial0/0
D    10.20.0.0/22 [90/2172416] via 10.0.0.2, 00:01:06, Serial0/0
D    10.100.78.0/24 [90/30720] via 10.100.17.7, 00:04:32, FastEthernet0/0
D    10.100.79.0/24 [90/30720] via 10.100.17.7, 00:04:33, FastEthernet0/0
D    10.100.89.0/24 [90/33280] via 10.100.17.7, 00:04:33, FastEthernet0/0
D    10.50.0.0/21 [90/2172416] via 10.0.0.3, 00:01:07, Serial0/0
D    10.100.48.0/24 [90/33280] via 10.100.17.7, 00:04:33, FastEthernet0/0
D    10.100.10.0/24 [90/33536] via 10.100.17.7, 00:04:33, FastEthernet0/0
D    10.100.8.0/24 [90/30976] via 10.100.17.7, 00:04:33, FastEthernet0/0
D    10.100.9.0/24 [90/30976] via 10.100.17.7, 00:04:32, FastEthernet0/0
D    10.100.7.0/24 [90/28416] via 10.100.17.7, 00:04:33, FastEthernet0/0
```

2.6 EIGRP Default Routing

Configuration

```
R4#
router eigrp 100
 network 0.0.0.0
!
ip route 0.0.0.0 0.0.0.0 Null0
```

Verification

```
SW2#show ip route 0.0.0.0
Routing entry for 0.0.0.0/0, supernet
  Known via "eigrp 100", distance 90, metric 28160, candidate default
path, type internal
  Redistributing via eigrp 100
  Last update from 10.100.48.4 on FastEthernet0/4, 00:04:00 ago
  Routing Descriptor Blocks:
  * 10.100.48.4, from 10.100.48.4, 00:04:00 ago, via FastEthernet0/4
    Route metric is 28160, traffic share count is 1
    Total delay is 100 microseconds, minimum bandwidth is 100000 Kbit
    Reliability 196/255, minimum MTU 1500 bytes
    Loading 1/255, Hops 1
```

Note

All destinations without a longer match route through R4. R4 replied with ICMP Unreachable since the packet is routed to Null0.

```
SW2#traceroute 1.2.3.4
```

```
Type escape sequence to abort.
Tracing the route to 1.2.3.4

 0 10.100.48.4 0 msec 9 msec 0 msec
 1 10.100.48.4 !H * !H
```

2.7 EIGRP Stub Routing

Configuration

```
R2#
router eigrp 100
  eigrp stub connected summary
```

```
R5#
router eigrp 100
  eigrp stub connected summary
```

Verification

Note

When R4's link to SW2 is up, default traffic follows this path.

```
SW3#traceroute 1.2.3.4
```

```
Type escape sequence to abort.
Tracing the route to 1.2.3.4
```

```
 1 10.100.89.8 4 msec 0 msec 4 msec
 2 10.100.48.4 4 msec 0 msec 4 msec
 3 10.100.48.4 !H * !H
```

When R4's link is down, default traffic transits through the Remote2 office (R5).

```
R4#config t
Enter configuration commands, one per line.  End with CNTL/Z.
R4(config)#interface Fa0/0
R4(config-if)#shutdown
%DUAL-5-NBRCHANGE: IP-EIGRP(0) 100: Neighbor 10.100.48.8
(FastEthernet0/0) is down: interface down
%LINK-5-CHANGED: Interface FastEthernet0/0, changed state to
administratively down
%LINEPROTO-5-UPDOWN: Line protocol on Interface FastEthernet0/0,
changed state to down
```

```
SW3#traceroute 1.2.3.4
```

```
Type escape sequence to abort.
Tracing the route to 1.2.3.4
```

```
 1 10.100.79.7 4 msec 4 msec 0 msec
 2 10.100.17.1 4 msec 4 msec 0 msec
 3 10.0.0.3 28 msec 28 msec 28 msec
 4 10.0.0.9 56 msec 52 msec 56 msec
 5 10.0.0.9 !H * !H
```

After EIGRP Stub Routing is configured on R2 and R5:

R4#show ip eigrp neighbors detail

IP-EIGRP neighbors for process 100

H	Address	Interface	Hold Uptime (sec)	SRTT (ms)	RTO	Q Cnt	Seq Num
2	10.100.48.8	Fa0/0	12 00:01:06	209	1254	0	819
Static neighbor							
Version 12.2/3.0, Retrans: 0, Retries: 0, Prefixes: 16							
1	10.0.0.11	Se0/0/0	2 00:01:39	849	5000	0	407
Version 12.4/1.2, Retrans: 0, Retries: 0, Prefixes: 3							
Stub Peer Advertising (CONNECTED SUMMARY) Routes Suppressing queries							
0	10.0.0.10	Se0/0/0	2 00:01:45	313	1878	0	399
Version 12.4/1.2, Retrans: 0, Retries: 0, Prefixes: 3							
Stub Peer Advertising (CONNECTED SUMMARY) Routes Suppressing queries							

R5's link to R1 is disabled.

R5#config t

Enter configuration commands, one per line. End with CNTL/Z.

R5(config)#interface Serial0/0/0.501

R5(config-subif)#shut

%DUAL-5-NBRCHANGE: IP-EIGRP(0) 100: Neighbor 10.0.0.1 (Serial0/0/0.501) is
down: interface down

R4 continues to learn R5's summary, and passes it onto R2 since split-horizon is disabled.

R4#show ip route 10.50.0.0

Routing entry for 10.50.0.0/21

Known via "eigrp 100", distance 90, metric 2172416, type internal

Redistributing via eigrp 100

Last update from 10.0.0.11 on Serial0/0/0, 00:02:33 ago

Routing Descriptor Blocks:

* 10.0.0.11, from 10.0.0.11, 00:02:33 ago, via Serial0/0/0

Route metric is 2172416, traffic share count is 1

Total delay is 20100 microseconds, minimum bandwidth is 1544 Kbit

Reliability 255/255, minimum MTU 1500 bytes

Loading 1/255, Hops 1

R2#show ip route 10.50.0.0

Routing entry for 10.50.0.0/21

Known via "eigrp 100", distance 90, metric 2692096, type internal

Redistributing via eigrp 100

Last update from 10.0.0.1 on Serial0/0.201, 00:00:15 ago

Routing Descriptor Blocks:

* 10.0.0.1, from 10.0.0.1, 00:00:15 ago, via Serial0/0.201

Route metric is 2692096, traffic share count is 1

Total delay is 40400 microseconds, minimum bandwidth is 1544 Kbit

Reliability 255/255, minimum MTU 1500 bytes

Loading 1/255, Hops 5

R2 is an EIGRP Stub Router, so this advertisement does not get passed onto R1. R1's only option to route to R5 is via the backdoor link to HQ2.

R1#show ip route 10.50.0.0

```
Routing entry for 10.50.0.0/21
  Known via "eigrp 100", distance 90, metric 2180096, type internal
  Redistributing via eigrp 100
  Last update from 10.100.17.7 on FastEthernet0/0, 00:00:21 ago
  Routing Descriptor Blocks:
  * 10.100.17.7, from 10.100.17.7, 00:00:21 ago, via FastEthernet0/0
    Route metric is 2180096, traffic share count is 1
    Total delay is 20400 microseconds, minimum bandwidth is 1544 Kbit
    Reliability 255/255, minimum MTU 1500 bytes
    Loading 1/255, Hops 4
```

R1#traceroute 10.50.0.5

```
Type escape sequence to abort.
Tracing the route to 10.50.0.5
```

```
 1 10.100.17.7 4 msec 4 msec 0 msec
 2 10.100.78.8 4 msec 0 msec 4 msec
 3 10.100.48.4 0 msec 4 msec 0 msec
 4 10.0.0.11 32 msec * 28 msec
```

3.1 Single Area OSPF

Configuration

```
R1#
router ospf 100
 network 0.0.0.0 255.255.255.255 area 0
 neighbor 10.0.0.2
 neighbor 10.0.0.3

R2#
interface Serial0/0.201 point-to-point
 ip ospf network non-broadcast
 ip ospf priority 0
!
interface Serial0/0.204 point-to-point
 ip ospf network non-broadcast
 ip ospf priority 0
!
router ospf 100
 network 0.0.0.0 255.255.255.255 area 0

R4#
router ospf 100
 network 0.0.0.0 255.255.255.255 area 0
 neighbor 10.0.0.10
 neighbor 10.0.0.11

R5#
interface Serial0/0/0.501 point-to-point
 ip ospf network non-broadcast
 ip ospf priority 0
!
interface Serial0/0/0.504 point-to-point
 ip ospf network non-broadcast
 ip ospf priority 0
!
router ospf 100
 network 0.0.0.0 255.255.255.255 area 0

SW1#
ip routing
!
router ospf 100
 network 0.0.0.0 255.255.255.255 area 0

SW2#
ip routing
!
router ospf 100
 network 0.0.0.0 255.255.255.255 area 0
```

```
SW3#
ip routing
!
router ospf 100
 network 0.0.0.0 255.255.255.255 area 0
```

```
SW4#
ip routing
!
router ospf 100
 network 0.0.0.0 255.255.255.255 area 0
```

Verification

Note

The network statement with an all 1's wildcard mask (255.255.255.255) means that all interfaces running IP are included in the area. Note that this does not affect the subnet mask advertised in the LSA. This can be verified as seen below.

R1#show ip ospf interface brief

Interface	PID	Area	IP Address/Mask	Cost	State	Nbrs	F/C
Lo0	100	0	10.255.255.1/32	1	LOOP	0/0	
Se0/0	100	0	10.0.0.1/29	64	DR	2/2	
Fa0/0	100	0	10.100.17.1/24	1	BDR	1/1	

R2#show ip ospf interface brief

Interface	PID	Area	IP Address/Mask	Cost	State	Nbrs	F/C
Se0/0.204	100	0	10.0.0.10/29	64	DROTH	1/1	
Se0/0.201	100	0	10.0.0.2/29	64	DROTH	1/1	
Lo0	100	0	10.255.255.2/32	1	LOOP	0/0	
Fa0/0.203	100	0	10.20.3.2/24	1	DR	0/0	
Fa0/0.202	100	0	10.20.2.2/24	1	DR	0/0	
Fa0/0.201	100	0	10.20.1.2/24	1	DR	0/0	
Fa0/0.200	100	0	10.20.0.2/24	1	DR	0/0	

R4#show ip ospf interface brief

Interface	PID	Area	IP Address/Mask	Cost	State	Nbrs	F/C
Lo0	100	0	10.255.255.4/32	1	LOOP	0/0	
Se0/0/0	100	0	10.0.0.9/29	64	DR	2/2	
Fa0/0	100	0	10.100.48.4/24	1	BDR	1/1	

R5#show ip ospf interface brief

Interface	PID	Area	IP Address/Mask	Cost	State	Nbrs	F/C
Lo0	100	0	10.255.255.5/32	1	LOOP	0/0	
Se0/0/0.504	100	0	10.0.0.11/29	64	DROTH	1/1	
Se0/0/0.501	100	0	10.0.0.3/29	64	DROTH	1/1	
Fa0/0.507	100	0	10.50.7.5/24	1	DR	0/0	
Fa0/0.506	100	0	10.50.6.5/24	1	DR	0/0	
Fa0/0.505	100	0	10.50.5.5/24	1	DR	0/0	
Fa0/0.504	100	0	10.50.4.5/24	1	DR	0/0	
Fa0/0.503	100	0	10.50.3.5/24	1	DR	0/0	
Fa0/0.502	100	0	10.50.2.5/24	1	DR	0/0	
Fa0/0.501	100	0	10.50.1.5/24	1	DR	0/0	
Fa0/0.500	100	0	10.50.0.5/24	1	DR	0/0	

SW1#show ip ospf interface brief

Interface	PID	Area	IP Address/Mask	Cost	State	Nbrs	F/C
Lo0	100	0	10.255.255.7/32	1	LOOP	0/0	
Po13	100	0	10.100.79.7/24	1	BDR	1/1	
Po12	100	0	10.100.78.7/24	1	BDR	1/1	
Fa0/19	100	0	10.100.107.7/24	1	BDR	1/1	
Fa0/1	100	0	10.100.17.7/24	1	DR	1/1	
Vl7	100	0	10.100.7.7/24	1	DR	0/0	

SW2#show ip ospf interface brief

Interface	PID	Area	IP Address/Mask	Cost	State	Nbrs	F/C
Lo0	100	0	10.255.255.8/32	1	LOOP	0/0	
Po24	100	0	10.100.108.8/24	1	BDR	1/1	
Po12	100	0	10.100.78.8/24	1	DR	1/1	
Fa0/16	100	0	10.100.89.8/24	1	BDR	1/1	
Fa0/4	100	0	10.100.48.8/24	1	DR	1/1	
Vl8	100	0	10.100.8.8/24	1	DR	0/0	

SW3#show ip ospf interface brief

Interface	PID	Area	IP Address/Mask	Cost	State	Nbrs	F/C
Lo0	100	0	10.255.255.9/32	1	LOOP	0/0	
Po13	100	0	10.100.79.9/24	1	DR	1/1	
Fa0/16	100	0	10.100.89.9/24	1	DR	1/1	
Vl9	100	0	10.100.9.9/24	1	DR	0/0	

SW4#show ip ospf interface brief

Interface	PID	Area	IP Address/Mask	Cost	State	Nbrs	F/C
Lo0	100	0	10.255.255.10/32	1	LOOP	0/0	
Po24	100	0	10.100.108.10/24	1	DR	1/1	
Fa0/13	100	0	10.100.107.10/24	1	DR	1/1	
Vl10	100	0	10.100.10.10/24	1	DR	0/0	

R1 and R4 must be elected the DRs for the NBMA segments since they are the only devices with full layer 2 connectivity to all devices on the subnet. This is accomplished by setting the OSPF priority value of the spokes to zero. Note that R1 and R4 also required the `neighbor` statement to define the unicast neighbors for the network type non-broadcast.

R1#show ip ospf neighbor

Neighbor ID	Pri	State	Dead Time	Address	Interface
10.255.255.2	0	FULL/DROTHER	00:01:58	10.0.0.2	Serial0/0
10.255.255.5	0	FULL/DROTHER	00:01:42	10.0.0.3	Serial0/0
10.255.255.7	1	FULL/DR	00:00:38	10.100.17.7	FastEthernet0/0

R2#show ip ospf neighbor

Neighbor ID	Pri	State	Dead Time	Address	Interface
10.255.255.4	1	FULL/DR	00:01:49	10.0.0.9	Serial0/0.204
10.255.255.1	1	FULL/DR	00:01:35	10.0.0.1	Serial0/0.201

R4#show ip ospf neighbor

Neighbor ID	Pri	State	Dead Time	Address	Interface
10.255.255.2	0	FULL/DROTHER	00:01:31	10.0.0.10	Serial0/0/0
10.255.255.5	0	FULL/DROTHER	00:01:47	10.0.0.11	Serial0/0/0
10.255.255.8	1	FULL/DR	00:00:34	10.100.48.8	FastEthernet0/0

R5#show ip ospf neighbor

Neighbor ID	Pri	State	Dead Time	Address	Interface
10.255.255.4	1	FULL/DR	00:01:45	10.0.0.9	Serial0/0/0.504
10.255.255.1	1	FULL/DR	00:01:31	10.0.0.1	Serial0/0/0.501

SW1#show ip ospf neighbor

Neighbor ID	Pri	State	Dead Time	Address	Interface
10.255.255.9	1	FULL/DR	00:00:39	10.100.79.9	Port-channel13
10.255.255.8	1	FULL/DR	00:00:30	10.100.78.8	Port-channel12
10.255.255.10	1	FULL/DR	00:00:39	10.100.107.10	FastEthernet0/19
10.255.255.1	1	FULL/BDR	00:00:39	10.100.17.1	FastEthernet0/1

SW2#show ip ospf neighbor

Neighbor ID	Pri	State	Dead Time	Address	Interface
10.255.255.10	1	FULL/DR	00:00:38	10.100.108.10	Port-channel24
10.255.255.7	1	FULL/BDR	00:00:38	10.100.78.7	Port-channel12
10.255.255.9	1	FULL/DR	00:00:38	10.100.89.9	FastEthernet0/16
10.255.255.4	1	FULL/BDR	00:00:34	10.100.48.4	FastEthernet0/4

SW3#show ip ospf neighbor

Neighbor ID	Pri	State	Dead Time	Address	Interface
10.255.255.7	1	FULL/BDR	00:00:37	10.100.79.7	Port-channel13
10.255.255.8	1	FULL/BDR	00:00:37	10.100.89.8	FastEthernet0/16

SW4#show ip ospf neighbor

Neighbor ID	Pri	State	Dead Time	Address	Interface
10.255.255.8	1	FULL/BDR	00:00:36	10.100.108.8	Port-channel24
10.255.255.7	1	FULL/BDR	00:00:36	10.100.107.7	FastEthernet0/13

R1#show ip route ospf

```

10.0.0.0/8 is variably subnetted, 33 subnets, 3 masks
O   10.255.255.10/32 [110/3] via 10.100.17.7, 00:14:53, FastEthernet0/0
O   10.255.255.8/32 [110/3] via 10.100.17.7, 00:14:53, FastEthernet0/0
O   10.100.108.0/24 [110/3] via 10.100.17.7, 00:14:53, FastEthernet0/0
O   10.0.0.8/29 [110/67] via 10.100.17.7, 00:14:53, FastEthernet0/0
O   10.255.255.9/32 [110/3] via 10.100.17.7, 00:14:53, FastEthernet0/0
O   10.100.107.0/24 [110/2] via 10.100.17.7, 00:14:53, FastEthernet0/0
O   10.255.255.2/32 [110/65] via 10.0.0.2, 00:14:53, Serial0/0
O   10.255.255.7/32 [110/2] via 10.100.17.7, 00:14:53, FastEthernet0/0
O   10.255.255.4/32 [110/4] via 10.100.17.7, 00:14:53, FastEthernet0/0
O   10.255.255.5/32 [110/65] via 10.0.0.3, 00:14:53, Serial0/0
O   10.20.2.0/24 [110/65] via 10.0.0.2, 00:14:53, Serial0/0
O   10.20.3.0/24 [110/65] via 10.0.0.2, 00:14:53, Serial0/0
O   10.20.0.0/24 [110/65] via 10.0.0.2, 00:14:53, Serial0/0
O   10.20.1.0/24 [110/65] via 10.0.0.2, 00:14:54, Serial0/0
O   10.100.78.0/24 [110/2] via 10.100.17.7, 00:14:54, FastEthernet0/0
O   10.100.79.0/24 [110/2] via 10.100.17.7, 00:14:54, FastEthernet0/0
O   10.100.89.0/24 [110/3] via 10.100.17.7, 00:14:54, FastEthernet0/0
O   10.50.0.0/24 [110/65] via 10.0.0.3, 00:14:54, Serial0/0
O   10.50.1.0/24 [110/65] via 10.0.0.3, 00:14:54, Serial0/0
O   10.50.2.0/24 [110/65] via 10.0.0.3, 00:14:54, Serial0/0
O   10.50.3.0/24 [110/65] via 10.0.0.3, 00:14:54, Serial0/0
O   10.50.4.0/24 [110/65] via 10.0.0.3, 00:14:54, Serial0/0
O   10.50.5.0/24 [110/65] via 10.0.0.3, 00:14:54, Serial0/0
O   10.50.6.0/24 [110/65] via 10.0.0.3, 00:14:54, Serial0/0
O   10.50.7.0/24 [110/65] via 10.0.0.3, 00:14:54, Serial0/0
O   10.100.48.0/24 [110/3] via 10.100.17.7, 00:14:54, FastEthernet0/0
O   10.100.10.0/24 [110/3] via 10.100.17.7, 00:14:54, FastEthernet0/0
O   10.100.8.0/24 [110/3] via 10.100.17.7, 00:14:54, FastEthernet0/0
O   10.100.9.0/24 [110/3] via 10.100.17.7, 00:14:55, FastEthernet0/0
O   10.100.7.0/24 [110/2] via 10.100.17.7, 00:14:55, FastEthernet0/0

```

R2#show ip route ospf

```

10.0.0.0/8 is variably subnetted, 33 subnets, 3 masks
O   10.255.255.10/32 [110/67] via 10.0.0.9, 00:14:57, Serial0/0.204
    [110/67] via 10.0.0.1, 00:14:57, Serial0/0.201
O   10.255.255.8/32 [110/66] via 10.0.0.9, 00:14:57, Serial0/0.204
O   10.100.108.0/24 [110/66] via 10.0.0.9, 00:14:57, Serial0/0.204
O   10.255.255.9/32 [110/67] via 10.0.0.9, 00:14:57, Serial0/0.204
    [110/67] via 10.0.0.1, 00:14:57, Serial0/0.201
O   10.100.107.0/24 [110/66] via 10.0.0.1, 00:14:57, Serial0/0.201
O   10.255.255.1/32 [110/65] via 10.0.0.1, 00:14:57, Serial0/0.201
O   10.255.255.7/32 [110/66] via 10.0.0.1, 00:14:57, Serial0/0.201
O   10.255.255.4/32 [110/65] via 10.0.0.9, 00:14:57, Serial0/0.204
O   10.255.255.5/32 [110/65] via 10.0.0.11, 00:14:57, Serial0/0.204
    [110/65] via 10.0.0.3, 00:14:57, Serial0/0.201
O   10.100.78.0/24 [110/66] via 10.0.0.9, 00:14:57, Serial0/0.204
    [110/66] via 10.0.0.1, 00:14:57, Serial0/0.201
O   10.100.79.0/24 [110/66] via 10.0.0.1, 00:14:58, Serial0/0.201
O   10.100.89.0/24 [110/66] via 10.0.0.9, 00:14:58, Serial0/0.204
O   10.50.0.0/24 [110/65] via 10.0.0.11, 00:14:58, Serial0/0.204
    [110/65] via 10.0.0.3, 00:14:58, Serial0/0.201
O   10.50.1.0/24 [110/65] via 10.0.0.11, 00:14:58, Serial0/0.204
    [110/65] via 10.0.0.3, 00:14:58, Serial0/0.201
O   10.50.2.0/24 [110/65] via 10.0.0.11, 00:14:58, Serial0/0.204

```



```

O      [110/65] via 10.0.0.3, 00:14:58, Serial0/0.201
O      10.50.3.0/24 [110/65] via 10.0.0.11, 00:14:58, Serial0/0.204
O      [110/65] via 10.0.0.3, 00:14:58, Serial0/0.201
O      10.50.4.0/24 [110/65] via 10.0.0.11, 00:14:58, Serial0/0.204
O      [110/65] via 10.0.0.3, 00:14:58, Serial0/0.201
O      10.50.5.0/24 [110/65] via 10.0.0.11, 00:14:58, Serial0/0.204
O      [110/65] via 10.0.0.3, 00:14:58, Serial0/0.201
O      10.50.6.0/24 [110/65] via 10.0.0.11, 00:14:59, Serial0/0.204
O      [110/65] via 10.0.0.3, 00:14:59, Serial0/0.201
O      10.50.7.0/24 [110/65] via 10.0.0.11, 00:14:59, Serial0/0.204
O      [110/65] via 10.0.0.3, 00:14:59, Serial0/0.201
O      10.100.48.0/24 [110/65] via 10.0.0.9, 00:14:59, Serial0/0.204
O      10.100.10.0/24 [110/67] via 10.0.0.9, 00:14:59, Serial0/0.204
O      [110/67] via 10.0.0.1, 00:14:59, Serial0/0.201
O      10.100.8.0/24 [110/66] via 10.0.0.9, 00:14:59, Serial0/0.204
O      10.100.9.0/24 [110/67] via 10.0.0.9, 00:14:59, Serial0/0.204
O      [110/67] via 10.0.0.1, 00:14:59, Serial0/0.201
O      10.100.7.0/24 [110/66] via 10.0.0.1, 00:14:59, Serial0/0.201
O      10.100.17.0/24 [110/65] via 10.0.0.1, 00:14:59, Serial0/0.201

```

R4#show ip route ospf

```

10.0.0.0/8 is variably subnetted, 33 subnets, 3 masks
O      10.255.255.10/32 [110/3] via 10.100.48.8, 00:15:27, FastEthernet0/0
O      10.255.255.8/32 [110/2] via 10.100.48.8, 00:15:27, FastEthernet0/0
O      10.100.108.0/24 [110/2] via 10.100.48.8, 00:15:27, FastEthernet0/0
O      10.255.255.9/32 [110/3] via 10.100.48.8, 00:15:27, FastEthernet0/0
O      10.100.107.0/24 [110/3] via 10.100.48.8, 00:15:27, FastEthernet0/0
O      10.255.255.2/32 [110/65] via 10.0.0.10, 00:15:12, Serial0/0/0
O      10.0.0.0/29 [110/67] via 10.100.48.8, 00:15:27, FastEthernet0/0
O      10.255.255.1/32 [110/4] via 10.100.48.8, 00:15:27, FastEthernet0/0
O      10.255.255.7/32 [110/3] via 10.100.48.8, 00:15:27, FastEthernet0/0
O      10.255.255.5/32 [110/65] via 10.0.0.11, 00:15:12, Serial0/0/0
O      10.20.2.0/24 [110/65] via 10.0.0.10, 00:15:12, Serial0/0/0
O      10.20.3.0/24 [110/65] via 10.0.0.10, 00:15:12, Serial0/0/0
O      10.20.0.0/24 [110/65] via 10.0.0.10, 00:15:12, Serial0/0/0
O      10.20.1.0/24 [110/65] via 10.0.0.10, 00:15:12, Serial0/0/0
O      10.100.78.0/24 [110/2] via 10.100.48.8, 00:15:27, FastEthernet0/0
O      10.100.79.0/24 [110/3] via 10.100.48.8, 00:15:27, FastEthernet0/0
O      10.100.89.0/24 [110/2] via 10.100.48.8, 00:15:27, FastEthernet0/0
O      10.50.0.0/24 [110/65] via 10.0.0.11, 00:15:12, Serial0/0/0
O      10.50.1.0/24 [110/65] via 10.0.0.11, 00:15:12, Serial0/0/0
O      10.50.2.0/24 [110/65] via 10.0.0.11, 00:15:12, Serial0/0/0
O      10.50.3.0/24 [110/65] via 10.0.0.11, 00:15:12, Serial0/0/0
O      10.50.4.0/24 [110/65] via 10.0.0.11, 00:15:12, Serial0/0/0
O      10.50.5.0/24 [110/65] via 10.0.0.11, 00:15:12, Serial0/0/0
O      10.50.6.0/24 [110/65] via 10.0.0.11, 00:15:12, Serial0/0/0
O      10.50.7.0/24 [110/65] via 10.0.0.11, 00:15:12, Serial0/0/0
O      10.100.10.0/24 [110/3] via 10.100.48.8, 00:15:27, FastEthernet0/0
O      10.100.8.0/24 [110/2] via 10.100.48.8, 00:15:27, FastEthernet0/0
O      10.100.9.0/24 [110/3] via 10.100.48.8, 00:15:27, FastEthernet0/0
O      10.100.7.0/24 [110/3] via 10.100.48.8, 00:15:27, FastEthernet0/0
O      10.100.17.0/24 [110/3] via 10.100.48.8, 00:15:29, FastEthernet0/0

```

R5#show ip route ospf

```
10.0.0.0/8 is variably subnetted, 33 subnets, 3 masks
O    10.255.255.10/32 [110/67] via 10.0.0.9, 00:15:15, Serial0/0/0.504
    [110/67] via 10.0.0.1, 00:15:05, Serial0/0/0.501
O    10.255.255.8/32 [110/66] via 10.0.0.9, 00:15:15, Serial0/0/0.504
O    10.100.108.0/24 [110/66] via 10.0.0.9, 00:15:15, Serial0/0/0.504
O    10.255.255.9/32 [110/67] via 10.0.0.9, 00:15:15, Serial0/0/0.504
    [110/67] via 10.0.0.1, 00:15:05, Serial0/0/0.501
O    10.100.107.0/24 [110/66] via 10.0.0.1, 00:15:05, Serial0/0/0.501
O    10.255.255.2/32 [110/65] via 10.0.0.10, 00:15:15, Serial0/0/0.504
    [110/65] via 10.0.0.2, 00:15:05, Serial0/0/0.501
O    10.255.255.1/32 [110/65] via 10.0.0.1, 00:15:05, Serial0/0/0.501
O    10.255.255.7/32 [110/66] via 10.0.0.1, 00:15:05, Serial0/0/0.501
O    10.255.255.4/32 [110/65] via 10.0.0.9, 00:15:15, Serial0/0/0.504
O    10.20.2.0/24 [110/65] via 10.0.0.10, 00:15:15, Serial0/0/0.504
    [110/65] via 10.0.0.2, 00:15:05, Serial0/0/0.501
O    10.20.3.0/24 [110/65] via 10.0.0.10, 00:15:15, Serial0/0/0.504
    [110/65] via 10.0.0.2, 00:15:05, Serial0/0/0.501
O    10.20.0.0/24 [110/65] via 10.0.0.10, 00:15:15, Serial0/0/0.504
    [110/65] via 10.0.0.2, 00:15:05, Serial0/0/0.501
O    10.20.1.0/24 [110/65] via 10.0.0.10, 00:15:15, Serial0/0/0.504
    [110/65] via 10.0.0.2, 00:15:05, Serial0/0/0.501
O    10.100.78.0/24 [110/66] via 10.0.0.9, 00:15:15, Serial0/0/0.504
    [110/66] via 10.0.0.1, 00:15:05, Serial0/0/0.501
O    10.100.79.0/24 [110/66] via 10.0.0.1, 00:15:05, Serial0/0/0.501
O    10.100.89.0/24 [110/66] via 10.0.0.9, 00:15:15, Serial0/0/0.504
O    10.100.48.0/24 [110/65] via 10.0.0.9, 00:15:15, Serial0/0/0.504
O    10.100.10.0/24 [110/67] via 10.0.0.9, 00:15:15, Serial0/0/0.504
    [110/67] via 10.0.0.1, 00:15:05, Serial0/0/0.501
O    10.100.8.0/24 [110/66] via 10.0.0.9, 00:15:15, Serial0/0/0.504
O    10.100.9.0/24 [110/67] via 10.0.0.9, 00:15:18, Serial0/0/0.504
    [110/67] via 10.0.0.1, 00:15:08, Serial0/0/0.501
O    10.100.7.0/24 [110/66] via 10.0.0.1, 00:15:08, Serial0/0/0.501
O    10.100.17.0/24 [110/65] via 10.0.0.1, 00:15:08, Serial0/0/0.501
```

SW1#show ip route ospf

```
10.0.0.0/8 is variably subnetted, 33 subnets, 3 masks
O    10.255.255.10/32 [110/2] via 10.100.107.10, 00:15:10, FastEthernet0/19
O    10.255.255.8/32 [110/2] via 10.100.78.8, 00:15:10, Port-channel12
O    10.100.108.0/24 [110/2] via 10.100.107.10, 00:15:10, FastEthernet0/19
    [110/2] via 10.100.78.8, 00:15:10, Port-channel12
O    10.0.0.8/29 [110/66] via 10.100.78.8, 00:15:10, Port-channel12
O    10.255.255.9/32 [110/2] via 10.100.79.9, 00:15:10, Port-channel13
O    10.255.255.2/32 [110/66] via 10.100.17.1, 00:15:11, FastEthernet0/1
O    10.0.0.0/29 [110/65] via 10.100.17.1, 00:15:11, FastEthernet0/1
O    10.255.255.1/32 [110/2] via 10.100.17.1, 00:15:11, FastEthernet0/1
O    10.255.255.4/32 [110/3] via 10.100.78.8, 00:15:11, Port-channel12
O    10.255.255.5/32 [110/66] via 10.100.17.1, 00:15:11, FastEthernet0/1
O    10.20.2.0/24 [110/66] via 10.100.17.1, 00:15:11, FastEthernet0/1
O    10.20.3.0/24 [110/66] via 10.100.17.1, 00:15:11, FastEthernet0/1
O    10.20.0.0/24 [110/66] via 10.100.17.1, 00:15:11, FastEthernet0/1
O    10.20.1.0/24 [110/66] via 10.100.17.1, 00:15:11, FastEthernet0/1
O    10.100.89.0/24 [110/2] via 10.100.79.9, 00:15:11, Port-channel13
    [110/2] via 10.100.78.8, 00:15:11, Port-channel12
O    10.50.0.0/24 [110/66] via 10.100.17.1, 00:15:11, FastEthernet0/1
O    10.50.1.0/24 [110/66] via 10.100.17.1, 00:15:11, FastEthernet0/1
O    10.50.2.0/24 [110/66] via 10.100.17.1, 00:15:11, FastEthernet0/1
O    10.50.3.0/24 [110/66] via 10.100.17.1, 00:15:12, FastEthernet0/1
O    10.50.4.0/24 [110/66] via 10.100.17.1, 00:15:12, FastEthernet0/1
O    10.50.5.0/24 [110/66] via 10.100.17.1, 00:15:12, FastEthernet0/1
O    10.50.6.0/24 [110/66] via 10.100.17.1, 00:15:12, FastEthernet0/1
O    10.50.7.0/24 [110/66] via 10.100.17.1, 00:15:12, FastEthernet0/1
O    10.100.48.0/24 [110/2] via 10.100.78.8, 00:15:12, Port-channel12
```

- O 10.100.10.0/24 [110/2] via 10.100.107.10, 00:15:12, FastEthernet0/19
- O 10.100.8.0/24 [110/2] via 10.100.78.8, 00:15:13, Port-channel12
- O 10.100.9.0/24 [110/2] via 10.100.79.9, 00:15:13, Port-channel13

SW2#show ip route ospf

- 10.0.0.0/8 is variably subnetted, 33 subnets, 3 masks
- O 10.255.255.10/32 [110/2] via 10.100.108.10, 00:15:14, Port-channel24
 - O 10.0.0.8/29 [110/65] via 10.100.48.4, 00:15:14, FastEthernet0/4
 - O 10.255.255.9/32 [110/2] via 10.100.89.9, 00:15:14, FastEthernet0/16
 - O 10.100.107.0/24 [110/2] via 10.100.108.10, 00:15:14, Port-channel24
[110/2] via 10.100.78.7, 00:15:14, Port-channel12
 - O 10.255.255.2/32 [110/66] via 10.100.48.4, 00:15:14, FastEthernet0/4
 - O 10.0.0.0/29 [110/66] via 10.100.78.7, 00:15:14, Port-channel12
 - O 10.255.255.1/32 [110/3] via 10.100.78.7, 00:15:14, Port-channel12
 - O 10.255.255.7/32 [110/2] via 10.100.78.7, 00:15:14, Port-channel12
 - O 10.255.255.4/32 [110/2] via 10.100.48.4, 00:15:14, FastEthernet0/4
 - O 10.255.255.5/32 [110/66] via 10.100.48.4, 00:15:14, FastEthernet0/4
 - O 10.20.2.0/24 [110/66] via 10.100.48.4, 00:15:14, FastEthernet0/4
 - O 10.20.3.0/24 [110/66] via 10.100.48.4, 00:15:14, FastEthernet0/4
 - O 10.20.0.0/24 [110/66] via 10.100.48.4, 00:15:15, FastEthernet0/4
 - O 10.20.1.0/24 [110/66] via 10.100.48.4, 00:15:15, FastEthernet0/4
 - O 10.100.79.0/24 [110/2] via 10.100.89.9, 00:15:15, FastEthernet0/16
[110/2] via 10.100.78.7, 00:15:15, Port-channel12
 - O 10.50.0.0/24 [110/66] via 10.100.48.4, 00:15:15, FastEthernet0/4
 - O 10.50.1.0/24 [110/66] via 10.100.48.4, 00:15:15, FastEthernet0/4
 - O 10.50.2.0/24 [110/66] via 10.100.48.4, 00:15:15, FastEthernet0/4
 - O 10.50.3.0/24 [110/66] via 10.100.48.4, 00:15:15, FastEthernet0/4
 - O 10.50.4.0/24 [110/66] via 10.100.48.4, 00:15:15, FastEthernet0/4
 - O 10.50.5.0/24 [110/66] via 10.100.48.4, 00:15:15, FastEthernet0/4
 - O 10.50.6.0/24 [110/66] via 10.100.48.4, 00:15:15, FastEthernet0/4
 - O 10.50.7.0/24 [110/66] via 10.100.48.4, 00:15:15, FastEthernet0/4
 - O 10.100.10.0/24 [110/2] via 10.100.108.10, 00:15:15, Port-channel24
 - O 10.100.9.0/24 [110/2] via 10.100.89.9, 00:15:15, FastEthernet0/16
 - O 10.100.7.0/24 [110/2] via 10.100.78.7, 00:15:16, Port-channel12
 - O 10.100.17.0/24 [110/2] via 10.100.78.7, 00:15:16, Port-channel12

SW3#show ip route ospf

- 10.0.0.0/8 is variably subnetted, 33 subnets, 3 masks
- O 10.255.255.10/32 [110/3] via 10.100.89.8, 00:15:17, FastEthernet0/16
[110/3] via 10.100.79.7, 00:15:17, Port-channel13
 - O 10.255.255.8/32 [110/2] via 10.100.89.8, 00:15:17, FastEthernet0/16
 - O 10.100.108.0/24 [110/2] via 10.100.89.8, 00:15:17, FastEthernet0/16
 - O 10.0.0.8/29 [110/66] via 10.100.89.8, 00:15:17, FastEthernet0/16
 - O 10.100.107.0/24 [110/2] via 10.100.79.7, 00:15:17, Port-channel13
 - O 10.255.255.2/32 [110/67] via 10.100.89.8, 00:15:18, FastEthernet0/16
[110/67] via 10.100.79.7, 00:15:18, Port-channel13
 - O 10.0.0.0/29 [110/66] via 10.100.79.7, 00:15:18, Port-channel13
 - O 10.255.255.1/32 [110/3] via 10.100.79.7, 00:15:18, Port-channel13
 - O 10.255.255.7/32 [110/2] via 10.100.79.7, 00:15:18, Port-channel13
 - O 10.255.255.4/32 [110/3] via 10.100.89.8, 00:15:18, FastEthernet0/16
 - O 10.255.255.5/32 [110/67] via 10.100.89.8, 00:15:18, FastEthernet0/16
[110/67] via 10.100.79.7, 00:15:18, Port-channel13
 - O 10.20.2.0/24 [110/67] via 10.100.89.8, 00:15:18, FastEthernet0/16
[110/67] via 10.100.79.7, 00:15:18, Port-channel13
 - O 10.20.3.0/24 [110/67] via 10.100.89.8, 00:15:18, FastEthernet0/16
[110/67] via 10.100.79.7, 00:15:18, Port-channel13
 - O 10.20.0.0/24 [110/67] via 10.100.89.8, 00:15:18, FastEthernet0/16
[110/67] via 10.100.79.7, 00:15:18, Port-channel13
 - O 10.20.1.0/24 [110/67] via 10.100.89.8, 00:15:19, FastEthernet0/16
[110/67] via 10.100.79.7, 00:15:19, Port-channel13
 - O 10.100.78.0/24 [110/2] via 10.100.89.8, 00:15:19, FastEthernet0/16
[110/2] via 10.100.79.7, 00:15:19, Port-channel13
 - O 10.50.0.0/24 [110/67] via 10.100.89.8, 00:15:19, FastEthernet0/16

```

O      10.50.1.0/24 [110/67] via 10.100.79.7, 00:15:19, Port-channel13
O      10.50.2.0/24 [110/67] via 10.100.89.8, 00:15:19, FastEthernet0/16
O      10.50.3.0/24 [110/67] via 10.100.79.7, 00:15:19, Port-channel13
O      10.50.4.0/24 [110/67] via 10.100.89.8, 00:15:19, FastEthernet0/16
O      10.50.5.0/24 [110/67] via 10.100.79.7, 00:15:19, Port-channel13
O      10.50.6.0/24 [110/67] via 10.100.89.8, 00:15:20, FastEthernet0/16
O      10.50.7.0/24 [110/67] via 10.100.79.7, 00:15:20, Port-channel13
O      10.100.48.0/24 [110/2] via 10.100.89.8, 00:15:21, FastEthernet0/16
O      10.100.10.0/24 [110/3] via 10.100.89.8, 00:15:21, FastEthernet0/16
O      10.100.8.0/24 [110/2] via 10.100.79.7, 00:15:21, Port-channel13
O      10.100.7.0/24 [110/2] via 10.100.89.8, 00:15:21, FastEthernet0/16
O      10.100.17.0/24 [110/2] via 10.100.79.7, 00:15:21, Port-channel13

```

SW4#show ip route ospf

```

10.0.0.0/8 is variably subnetted, 33 subnets, 3 masks
O      10.255.255.8/32 [110/2] via 10.100.108.8, 00:15:22, Port-channel24
O      10.0.0.8/29 [110/66] via 10.100.108.8, 00:15:22, Port-channel24
O      10.255.255.9/32 [110/3] via 10.100.108.8, 00:15:22, Port-channel24
O      10.255.255.2/32 [110/67] via 10.100.107.7, 00:15:22, FastEthernet0/13
O      10.0.0.0/29 [110/66] via 10.100.108.8, 00:15:22, Port-channel24
O      10.255.255.1/32 [110/3] via 10.100.107.7, 00:15:22, FastEthernet0/13
O      10.255.255.7/32 [110/2] via 10.100.107.7, 00:15:22, FastEthernet0/13
O      10.255.255.4/32 [110/3] via 10.100.108.8, 00:15:22, Port-channel24
O      10.255.255.5/32 [110/67] via 10.100.107.7, 00:15:22, FastEthernet0/13
O      10.20.2.0/24 [110/67] via 10.100.108.8, 00:15:22, Port-channel24
O      10.20.3.0/24 [110/67] via 10.100.107.7, 00:15:23, FastEthernet0/13
O      10.20.0.0/24 [110/67] via 10.100.108.8, 00:15:23, Port-channel24
O      10.20.1.0/24 [110/67] via 10.100.107.7, 00:15:23, FastEthernet0/13
O      10.100.78.0/24 [110/2] via 10.100.108.8, 00:15:24, Port-channel24
O      10.100.79.0/24 [110/2] via 10.100.107.7, 00:15:24, FastEthernet0/13
O      10.100.89.0/24 [110/2] via 10.100.108.8, 00:15:24, Port-channel24
O      10.50.0.0/24 [110/67] via 10.100.108.8, 00:15:24, Port-channel24
O      10.50.1.0/24 [110/67] via 10.100.107.7, 00:15:24, FastEthernet0/13
O      10.50.2.0/24 [110/67] via 10.100.108.8, 00:15:24, Port-channel24
O      10.50.3.0/24 [110/67] via 10.100.107.7, 00:15:24, FastEthernet0/13
O      10.50.4.0/24 [110/67] via 10.100.108.8, 00:15:24, Port-channel24
O      10.50.5.0/24 [110/67] via 10.100.107.7, 00:15:25, FastEthernet0/13
O      10.50.6.0/24 [110/67] via 10.100.108.8, 00:15:25, Port-channel24
O      10.50.7.0/24 [110/67] via 10.100.107.7, 00:15:25, FastEthernet0/13

```

```

    [110/67] via 10.100.107.7, 00:15:25, FastEthernet0/13
O    10.100.48.0/24 [110/2] via 10.100.108.8, 00:15:25, Port-channel24
O    10.100.8.0/24 [110/2] via 10.100.108.8, 00:15:25, Port-channel24
O    10.100.9.0/24 [110/3] via 10.100.108.8, 00:15:25, Port-channel24
    [110/3] via 10.100.107.7, 00:15:25, FastEthernet0/13
O    10.100.7.0/24 [110/2] via 10.100.107.7, 00:15:25, FastEthernet0/13
O    10.100.17.0/24 [110/2] via 10.100.107.7, 00:15:25, FastEthernet0/13

```

Since the entire network is one flat area, the OSPF database consists of only Type-1 Router LSA advertisements for each node in the SPF graph, and Type-2 Network LSA advertisements for the DRs.

R1#show ip ospf database

OSPF Router with ID (10.255.255.1) (Process ID 100)

Router Link States (Area 0)

Link ID count	ADV Router	Age	Seq#	Checksum	Link
10.255.255.1	10.255.255.1	1021	0x80000003	0x00A3EE	3
10.255.255.2	10.255.255.2	1025	0x80000005	0x001753	7
10.255.255.4	10.255.255.4	1034	0x80000003	0x002A0D	3
10.255.255.5	10.255.255.5	1025	0x80000003	0x00A5F7	11
10.255.255.7	10.255.255.7	1186	0x80000003	0x001C34	6
10.255.255.8	10.255.255.8	1186	0x80000003	0x001FD3	6
10.255.255.9	10.255.255.9	1186	0x80000002	0x00BD62	4
10.255.255.10	10.255.255.10	1187	0x80000002	0x008930	4

Net Link States (Area 0)

Link ID	ADV Router	Age	Seq#	Checksum
10.0.0.1	10.255.255.1	1020	0x80000001	0x005CA4
10.0.0.9	10.255.255.4	1034	0x80000001	0x0018DA
10.100.17.7	10.255.255.7	1191	0x80000001	0x00EA9B
10.100.48.8	10.255.255.8	1193	0x80000001	0x00B8A8
10.100.78.8	10.255.255.8	1193	0x80000001	0x0097A8
10.100.79.9	10.255.255.9	1189	0x80000001	0x0086B5
10.100.89.9	10.255.255.9	1189	0x80000001	0x00260B
10.100.107.10	10.255.255.10	1188	0x80000001	0x004BD1
10.100.108.10	10.255.255.10	1188	0x80000001	0x004ECC

All routers in the area share an identical copy of the OSPF database.

R2#show ip ospf database

OSPF Router with ID (10.255.255.2) (Process ID 100)

Router Link States (Area 0)

Link ID count	ADV Router	Age	Seq#	Checksum	Link
10.255.255.1	10.255.255.1	1026	0x80000003	0x00A3EE	3
10.255.255.2	10.255.255.2	1025	0x80000005	0x001753	7
10.255.255.4	10.255.255.4	1037	0x80000003	0x002A0D	3
10.255.255.5	10.255.255.5	1027	0x80000003	0x00A5F7	11
10.255.255.7	10.255.255.7	1191	0x80000003	0x001C34	6
10.255.255.8	10.255.255.8	1191	0x80000003	0x001FD3	6
10.255.255.9	10.255.255.9	1191	0x80000002	0x00BD62	4
10.255.255.10	10.255.255.10	1192	0x80000002	0x008930	4

Net Link States (Area 0)

Link ID	ADV Router	Age	Seq#	Checksum
10.0.0.1	10.255.255.1	1026	0x80000001	0x005CA4
10.0.0.9	10.255.255.4	1037	0x80000001	0x0018DA
10.100.17.7	10.255.255.7	1197	0x80000001	0x00EA9B
10.100.48.8	10.255.255.8	1197	0x80000001	0x00B8A8
10.100.78.8	10.255.255.8	1197	0x80000001	0x0097A8
10.100.79.9	10.255.255.9	1193	0x80000001	0x0086B5
10.100.89.9	10.255.255.9	1193	0x80000001	0x00260B
10.100.107.10	10.255.255.10	1193	0x80000001	0x004BD1
10.100.108.10	10.255.255.10	1193	0x80000001	0x004ECC

3.2 Multi-Area OSPF

```
R1#
interface Loopback0
 ip ospf 100 area 0
!
interface FastEthernet0/0
 ip ospf 100 area 0
!
interface Serial0/0
 ip ospf 100 area 1245
!
router ospf 100
 neighbor 10.0.0.2
 neighbor 10.0.0.3

R2#
interface Serial0/0.201 point-to-point
 ip ospf network non-broadcast
 ip ospf priority 0
!
interface Serial0/0.204 point-to-point
 ip ospf network non-broadcast
 ip ospf priority 0
!
router ospf 100
 network 0.0.0.0 255.255.255.255 area 1245

R4#
interface Loopback0
 ip ospf 100 area 0
!
interface FastEthernet0/0
 ip ospf 100 area 0
!
interface Serial0/0/0
 ip ospf 100 area 1245
!
router ospf 100
 neighbor 10.0.0.10
 neighbor 10.0.0.11

R5#
interface Serial0/0/0.501 point-to-point
 ip ospf network non-broadcast
 ip ospf priority 0
!
interface Serial0/0/0.504 point-to-point
 ip ospf network non-broadcast
 ip ospf priority 0
!
router ospf 100
 network 0.0.0.0 255.255.255.255 area 1245
```

```
SW1#
ip routing
!
router ospf 100
 network 10.100.7.7 0.0.0.0 area 0
 network 10.100.17.7 0.0.0.0 area 0
 network 10.100.107.7 0.0.0.0 area 7810
 network 10.100.78.7 0.0.0.0 area 0
 network 10.100.79.7 0.0.0.0 area 789
 network 10.255.255.7 0.0.0.0 area 0

SW2#
ip routing
!
router ospf 100
 network 10.100.8.8 0.0.0.0 area 0
 network 10.100.48.8 0.0.0.0 area 0
 network 10.100.89.8 0.0.0.0 area 789
 network 10.100.78.8 0.0.0.0 area 0
 network 10.100.108.8 0.0.0.0 area 7810
 network 10.255.255.8 0.0.0.0 area 0

SW3#
ip routing
!
router ospf 100
 network 0.0.0.0 255.255.255.255 area 789

SW4#
ip routing
!
router ospf 100
 network 0.0.0.0 255.255.255.255 area 7810
```

 **Note**

OSPF can be enabled at the link level, or under the process with the **network** statement. A wildcard mask of all 0's (0.0.0.0) means that only the interface with that IP address is running OSPF. There are many variations for the above solution, but all should result in the below output from the **show ip ospf interface brief**.

R1#show ip ospf interface brief

Interface	PID	Area	IP Address/Mask	Cost	State	Nbrs	F/C
Fa0/0	100	0	10.100.17.1/24	1	BDR	1/1	
Lo0	100	0	10.255.255.1/32	1	LOOP	0/0	
Se0/0	100	1245	10.0.0.1/29	64	DR	2/2	

R2#show ip ospf interface brief

Interface	PID	Area	IP Address/Mask	Cost	State	Nbrs	F/C
Lo0	100	1245	10.255.255.2/32	1	LOOP	0/0	
Se0/0.204	100	1245	10.0.0.10/29	64	DROTH	1/1	
Se0/0.201	100	1245	10.0.0.2/29	64	DROTH	1/1	
Fa0/0.203	100	1245	10.20.3.2/24	1	DR	0/0	
Fa0/0.202	100	1245	10.20.2.2/24	1	DR	0/0	
Fa0/0.201	100	1245	10.20.1.2/24	1	DR	0/0	
Fa0/0.200	100	1245	10.20.0.2/24	1	DR	0/0	

R4#show ip ospf interface brief

Interface	PID	Area	IP Address/Mask	Cost	State	Nbrs	F/C
Lo0	100	0	10.255.255.4/32	1	LOOP	0/0	
Fa0/0	100	0	10.100.48.4/24	1	BDR	1/1	
Se0/0/0	100	1245	10.0.0.9/29	64	DR	2/2	

R5#show ip ospf interface brief

Interface	PID	Area	IP Address/Mask	Cost	State	Nbrs	F/C
Lo0	100	1245	10.255.255.5/32	1	LOOP	0/0	
Se0/0/0.504	100	1245	10.0.0.11/29	64	DROTH	1/1	
Se0/0/0.501	100	1245	10.0.0.3/29	64	DROTH	1/1	
Fa0/0.507	100	1245	10.50.7.5/24	1	DR	0/0	
Fa0/0.506	100	1245	10.50.6.5/24	1	DR	0/0	
Fa0/0.505	100	1245	10.50.5.5/24	1	DR	0/0	
Fa0/0.504	100	1245	10.50.4.5/24	1	DR	0/0	
Fa0/0.503	100	1245	10.50.3.5/24	1	DR	0/0	
Fa0/0.502	100	1245	10.50.2.5/24	1	DR	0/0	
Fa0/0.501	100	1245	10.50.1.5/24	1	DR	0/0	
Fa0/0.500	100	1245	10.50.0.5/24	1	DR	0/0	

SW1#show ip ospf interface brief

Interface	PID	Area	IP Address/Mask	Cost	State	Nbrs	F/C
Lo0	100	0	10.255.255.7/32	1	LOOP	0/0	
Po12	100	0	10.100.78.7/24	1	BDR	1/1	
Fa0/1	100	0	10.100.17.7/24	1	DR	1/1	
Vl7	100	0	10.100.7.7/24	1	DR	0/0	
Po13	100	789	10.100.79.7/24	1	BDR	1/1	
Fa0/19	100	7810	10.100.107.7/24	1	BDR	1/1	

SW2#show ip ospf interface brief

Interface	PID	Area	IP Address/Mask	Cost	State	Nbrs	F/C
Lo0	100	0	10.255.255.8/32	1	LOOP	0/0	
Po12	100	0	10.100.78.8/24	1	DR	1/1	
Fa0/4	100	0	10.100.48.8/24	1	DR	1/1	
Vl8	100	0	10.100.8.8/24	1	DR	0/0	
Fa0/16	100	789	10.100.89.8/24	1	BDR	1/1	
Po24	100	7810	10.100.108.8/24	1	BDR	1/1	

SW3#show ip ospf interface brief

Interface	PID	Area	IP Address/Mask	Cost	State	Nbrs	F/C
Lo0	100	789	10.255.255.9/32	1	LOOP	0/0	
Po13	100	789	10.100.79.9/24	1	DR	1/1	
Fa0/16	100	789	10.100.89.9/24	1	DR	1/1	
Vl9	100	789	10.100.9.9/24	1	DR	0/0	

SW4#show ip ospf interface brief

Interface	PID	Area	IP Address/Mask	Cost	State	Nbrs	F/C
Lo0	100	7810	10.255.255.10/32	1	LOOP	0/0	
Po24	100	7810	10.100.108.10/24	1	DR	1/1	
Fa0/13	100	7810	10.100.107.10/24	1	DR	1/1	
Vl10	100	7810	10.100.10.10/24	1	DR	0/0	

The routing table now consists of both intra-area routes (O) and inter-area routes (O IA).

R1#show ip route ospf

```

10.0.0.0/8 is variably subnetted, 33 subnets, 3 masks
O IA 10.255.255.10/32 [110/3] via 10.100.17.7, 00:04:48, FastEthernet0/0
O    10.255.255.8/32 [110/3] via 10.100.17.7, 00:06:16, FastEthernet0/0
O IA 10.100.108.0/24 [110/3] via 10.100.17.7, 00:04:48, FastEthernet0/0
O    10.0.0.8/29 [110/128] via 10.0.0.3, 00:04:48, Serial0/0
      [110/128] via 10.0.0.2, 00:04:48, Serial0/0
O IA 10.255.255.9/32 [110/3] via 10.100.17.7, 00:04:48, FastEthernet0/0
O IA 10.100.107.0/24 [110/2] via 10.100.17.7, 00:04:48, FastEthernet0/0
O    10.255.255.2/32 [110/65] via 10.0.0.2, 00:04:48, Serial0/0
O    10.255.255.7/32 [110/2] via 10.100.17.7, 00:06:16, FastEthernet0/0
O    10.255.255.4/32 [110/4] via 10.100.17.7, 00:06:16, FastEthernet0/0
O    10.255.255.5/32 [110/65] via 10.0.0.3, 00:04:48, Serial0/0
O    10.20.2.0/24 [110/65] via 10.0.0.2, 00:04:48, Serial0/0
O    10.20.3.0/24 [110/65] via 10.0.0.2, 00:04:48, Serial0/0
O    10.20.0.0/24 [110/65] via 10.0.0.2, 00:04:49, Serial0/0
O    10.20.1.0/24 [110/65] via 10.0.0.2, 00:04:49, Serial0/0
O    10.100.78.0/24 [110/2] via 10.100.17.7, 00:06:18, FastEthernet0/0
O IA 10.100.79.0/24 [110/2] via 10.100.17.7, 00:04:49, FastEthernet0/0
O IA 10.100.89.0/24 [110/3] via 10.100.17.7, 00:04:49, FastEthernet0/0
O    10.50.0.0/24 [110/65] via 10.0.0.3, 00:04:49, Serial0/0
O    10.50.1.0/24 [110/65] via 10.0.0.3, 00:04:49, Serial0/0
O    10.50.2.0/24 [110/65] via 10.0.0.3, 00:04:49, Serial0/0
O    10.50.3.0/24 [110/65] via 10.0.0.3, 00:04:49, Serial0/0
O    10.50.4.0/24 [110/65] via 10.0.0.3, 00:04:49, Serial0/0
O    10.50.5.0/24 [110/65] via 10.0.0.3, 00:04:49, Serial0/0
O    10.50.6.0/24 [110/65] via 10.0.0.3, 00:04:49, Serial0/0
O    10.50.7.0/24 [110/65] via 10.0.0.3, 00:04:49, Serial0/0
O    10.100.48.0/24 [110/3] via 10.100.17.7, 00:06:18, FastEthernet0/0
O IA 10.100.10.0/24 [110/3] via 10.100.17.7, 00:04:49, FastEthernet0/0
O    10.100.8.0/24 [110/3] via 10.100.17.7, 00:06:19, FastEthernet0/0
O IA 10.100.9.0/24 [110/3] via 10.100.17.7, 00:04:50, FastEthernet0/0
O    10.100.7.0/24 [110/2] via 10.100.17.7, 00:06:19, FastEthernet0/0
    
```

R2#show ip route ospf

```

10.0.0.0/8 is variably subnetted, 33 subnets, 3 masks
O IA 10.255.255.10/32 [110/67] via 10.0.0.9, 00:05:02, Serial0/0.204
      [110/67] via 10.0.0.1, 00:05:02, Serial0/0.201
O IA 10.255.255.8/32 [110/66] via 10.0.0.9, 00:05:02, Serial0/0.204
O IA 10.100.108.0/24 [110/66] via 10.0.0.9, 00:05:02, Serial0/0.204
O IA 10.255.255.9/32 [110/67] via 10.0.0.9, 00:05:02, Serial0/0.204
      [110/67] via 10.0.0.1, 00:05:02, Serial0/0.201
O IA 10.100.107.0/24 [110/66] via 10.0.0.1, 00:05:02, Serial0/0.201
O IA 10.255.255.1/32 [110/65] via 10.0.0.1, 00:05:02, Serial0/0.201
O IA 10.255.255.7/32 [110/66] via 10.0.0.1, 00:05:02, Serial0/0.201
O IA 10.255.255.4/32 [110/65] via 10.0.0.9, 00:05:02, Serial0/0.204
O 10.255.255.5/32 [110/65] via 10.0.0.11, 00:05:02, Serial0/0.204
      [110/65] via 10.0.0.3, 00:05:02, Serial0/0.201
O IA 10.100.78.0/24 [110/66] via 10.0.0.9, 00:05:02, Serial0/0.204
      [110/66] via 10.0.0.1, 00:05:02, Serial0/0.201
O IA 10.100.79.0/24 [110/66] via 10.0.0.1, 00:05:03, Serial0/0.201
O IA 10.100.89.0/24 [110/66] via 10.0.0.9, 00:05:03, Serial0/0.204
O 10.50.0.0/24 [110/65] via 10.0.0.11, 00:05:03, Serial0/0.204
      [110/65] via 10.0.0.3, 00:05:03, Serial0/0.201
O 10.50.1.0/24 [110/65] via 10.0.0.11, 00:05:03, Serial0/0.204
      [110/65] via 10.0.0.3, 00:05:03, Serial0/0.201
O 10.50.2.0/24 [110/65] via 10.0.0.11, 00:05:03, Serial0/0.204
      [110/65] via 10.0.0.3, 00:05:03, Serial0/0.201
O 10.50.3.0/24 [110/65] via 10.0.0.11, 00:05:03, Serial0/0.204
      [110/65] via 10.0.0.3, 00:05:03, Serial0/0.201
O 10.50.4.0/24 [110/65] via 10.0.0.11, 00:05:03, Serial0/0.204
      [110/65] via 10.0.0.3, 00:05:03, Serial0/0.201
O 10.50.5.0/24 [110/65] via 10.0.0.11, 00:05:03, Serial0/0.204
      [110/65] via 10.0.0.3, 00:05:03, Serial0/0.201
O 10.50.6.0/24 [110/65] via 10.0.0.11, 00:05:04, Serial0/0.204
      [110/65] via 10.0.0.3, 00:05:04, Serial0/0.201
O 10.50.7.0/24 [110/65] via 10.0.0.11, 00:05:04, Serial0/0.204
      [110/65] via 10.0.0.3, 00:05:04, Serial0/0.201
O IA 10.100.48.0/24 [110/65] via 10.0.0.9, 00:05:04, Serial0/0.204
O IA 10.100.10.0/24 [110/67] via 10.0.0.9, 00:05:04, Serial0/0.204
      [110/67] via 10.0.0.1, 00:05:04, Serial0/0.201
O IA 10.100.8.0/24 [110/66] via 10.0.0.9, 00:05:04, Serial0/0.204
O IA 10.100.9.0/24 [110/67] via 10.0.0.9, 00:05:04, Serial0/0.204
      [110/67] via 10.0.0.1, 00:05:04, Serial0/0.201
O IA 10.100.7.0/24 [110/66] via 10.0.0.1, 00:05:04, Serial0/0.201
O IA 10.100.17.0/24 [110/65] via 10.0.0.1, 00:05:04, Serial0/0.201

```

R4#show ip route ospf

```

10.0.0.0/8 is variably subnetted, 33 subnets, 3 masks
O IA 10.255.255.10/32 [110/3] via 10.100.48.8, 00:06:09, FastEthernet0/0
O 10.255.255.8/32 [110/2] via 10.100.48.8, 00:06:29, FastEthernet0/0
O IA 10.100.108.0/24 [110/2] via 10.100.48.8, 00:06:29, FastEthernet0/0
O IA 10.255.255.9/32 [110/3] via 10.100.48.8, 00:06:19, FastEthernet0/0
O IA 10.100.107.0/24 [110/3] via 10.100.48.8, 00:05:07, FastEthernet0/0
O 10.255.255.2/32 [110/65] via 10.0.0.10, 00:05:07, Serial0/0/0
O 10.0.0.0/29 [110/128] via 10.0.0.11, 00:05:07, Serial0/0/0
      [110/128] via 10.0.0.10, 00:05:07, Serial0/0/0
O 10.255.255.1/32 [110/4] via 10.100.48.8, 00:06:19, FastEthernet0/0
O 10.255.255.7/32 [110/3] via 10.100.48.8, 00:06:19, FastEthernet0/0
O 10.255.255.5/32 [110/65] via 10.0.0.11, 00:05:07, Serial0/0/0
O 10.20.2.0/24 [110/65] via 10.0.0.10, 00:05:07, Serial0/0/0
O 10.20.3.0/24 [110/65] via 10.0.0.10, 00:05:07, Serial0/0/0
O 10.20.0.0/24 [110/65] via 10.0.0.10, 00:05:07, Serial0/0/0
O 10.20.1.0/24 [110/65] via 10.0.0.10, 00:05:07, Serial0/0/0
O 10.100.78.0/24 [110/2] via 10.100.48.8, 00:06:29, FastEthernet0/0
O IA 10.100.79.0/24 [110/3] via 10.100.48.8, 00:05:07, FastEthernet0/0
O IA 10.100.89.0/24 [110/2] via 10.100.48.8, 00:06:29, FastEthernet0/0

```

```

O      10.50.0.0/24 [110/65] via 10.0.0.11, 00:05:07, Serial0/0/0
O      10.50.1.0/24 [110/65] via 10.0.0.11, 00:05:07, Serial0/0/0
O      10.50.2.0/24 [110/65] via 10.0.0.11, 00:05:07, Serial0/0/0
O      10.50.3.0/24 [110/65] via 10.0.0.11, 00:05:07, Serial0/0/0
O      10.50.4.0/24 [110/65] via 10.0.0.11, 00:05:07, Serial0/0/0
O      10.50.5.0/24 [110/65] via 10.0.0.11, 00:05:07, Serial0/0/0
O      10.50.6.0/24 [110/65] via 10.0.0.11, 00:05:07, Serial0/0/0
O      10.50.7.0/24 [110/65] via 10.0.0.11, 00:05:07, Serial0/0/0
O IA   10.100.10.0/24 [110/3] via 10.100.48.8, 00:06:09, FastEthernet0/0
O      10.100.8.0/24 [110/2] via 10.100.48.8, 00:06:29, FastEthernet0/0
O IA   10.100.9.0/24 [110/3] via 10.100.48.8, 00:06:21, FastEthernet0/0
O      10.100.7.0/24 [110/3] via 10.100.48.8, 00:06:21, FastEthernet0/0
O      10.100.17.0/24 [110/3] via 10.100.48.8, 00:06:21, FastEthernet0/0

```

R5#show ip route ospf

```

10.0.0.0/8 is variably subnetted, 33 subnets, 3 masks
O IA   10.255.255.10/32 [110/67] via 10.0.0.9, 00:05:00, Serial0/0/0.504
      [110/67] via 10.0.0.1, 00:05:46, Serial0/0/0.501
O IA   10.255.255.8/32 [110/66] via 10.0.0.9, 00:05:00, Serial0/0/0.504
O IA   10.100.108.0/24 [110/66] via 10.0.0.9, 00:05:00, Serial0/0/0.504
O IA   10.255.255.9/32 [110/67] via 10.0.0.9, 00:05:00, Serial0/0/0.504
      [110/67] via 10.0.0.1, 00:05:46, Serial0/0/0.501
O IA   10.100.107.0/24 [110/66] via 10.0.0.1, 00:05:46, Serial0/0/0.501
O      10.255.255.2/32 [110/65] via 10.0.0.10, 00:05:10, Serial0/0/0.504
      [110/65] via 10.0.0.2, 00:05:36, Serial0/0/0.501
O IA   10.255.255.1/32 [110/65] via 10.0.0.1, 00:05:46, Serial0/0/0.501
O IA   10.255.255.7/32 [110/66] via 10.0.0.1, 00:05:46, Serial0/0/0.501
O IA   10.255.255.4/32 [110/65] via 10.0.0.9, 00:05:00, Serial0/0/0.504
O      10.20.2.0/24 [110/65] via 10.0.0.10, 00:05:10, Serial0/0/0.504
      [110/65] via 10.0.0.2, 00:05:36, Serial0/0/0.501
O      10.20.3.0/24 [110/65] via 10.0.0.10, 00:05:10, Serial0/0/0.504
      [110/65] via 10.0.0.2, 00:05:36, Serial0/0/0.501
O      10.20.0.0/24 [110/65] via 10.0.0.10, 00:05:10, Serial0/0/0.504
      [110/65] via 10.0.0.2, 00:05:36, Serial0/0/0.501
O      10.20.1.0/24 [110/65] via 10.0.0.10, 00:05:10, Serial0/0/0.504
      [110/65] via 10.0.0.2, 00:05:36, Serial0/0/0.501
O IA   10.100.78.0/24 [110/66] via 10.0.0.9, 00:05:00, Serial0/0/0.504
      [110/66] via 10.0.0.1, 00:05:46, Serial0/0/0.501
O IA   10.100.79.0/24 [110/66] via 10.0.0.1, 00:05:46, Serial0/0/0.501
O IA   10.100.89.0/24 [110/66] via 10.0.0.9, 00:05:00, Serial0/0/0.504
O IA   10.100.48.0/24 [110/65] via 10.0.0.9, 00:05:00, Serial0/0/0.504
O IA   10.100.10.0/24 [110/67] via 10.0.0.9, 00:05:00, Serial0/0/0.504
      [110/67] via 10.0.0.1, 00:05:46, Serial0/0/0.501
O IA   10.100.8.0/24 [110/66] via 10.0.0.9, 00:05:03, Serial0/0/0.504
O IA   10.100.9.0/24 [110/67] via 10.0.0.9, 00:05:03, Serial0/0/0.504
      [110/67] via 10.0.0.1, 00:05:49, Serial0/0/0.501
O IA   10.100.7.0/24 [110/66] via 10.0.0.1, 00:05:49, Serial0/0/0.501
O IA   10.100.17.0/24 [110/65] via 10.0.0.1, 00:05:49, Serial0/0/0.501

```

SW1#show ip route ospf

```
10.0.0.0/8 is variably subnetted, 33 subnets, 3 masks
O      10.255.255.10/32 [110/2] via 10.100.107.10, 00:06:13, FastEthernet0/19
O      10.255.255.8/32 [110/2] via 10.100.78.8, 00:06:33, Port-channel12
O      10.100.108.0/24 [110/2] via 10.100.107.10, 00:06:13, FastEthernet0/19
O IA   10.0.0.8/29 [110/66] via 10.100.78.8, 00:05:51, Port-channel12
O      10.255.255.9/32 [110/2] via 10.100.79.9, 00:06:23, Port-channel13
O IA   10.255.255.2/32 [110/66] via 10.100.17.1, 00:05:15, FastEthernet0/1
O IA   10.0.0.0/29 [110/65] via 10.100.17.1, 00:05:16, FastEthernet0/1
O      10.255.255.1/32 [110/2] via 10.100.17.1, 00:06:34, FastEthernet0/1
O      10.255.255.4/32 [110/3] via 10.100.78.8, 00:06:34, Port-channel12
O IA   10.255.255.5/32 [110/66] via 10.100.17.1, 00:05:16, FastEthernet0/1
O IA   10.20.2.0/24 [110/66] via 10.100.17.1, 00:05:16, FastEthernet0/1
O IA   10.20.3.0/24 [110/66] via 10.100.17.1, 00:05:16, FastEthernet0/1
O IA   10.20.0.0/24 [110/66] via 10.100.17.1, 00:05:16, FastEthernet0/1
O IA   10.20.1.0/24 [110/66] via 10.100.17.1, 00:05:16, FastEthernet0/1
O      10.100.89.0/24 [110/2] via 10.100.79.9, 00:06:25, Port-channel13
O IA   10.50.0.0/24 [110/66] via 10.100.17.1, 00:05:16, FastEthernet0/1
O IA   10.50.1.0/24 [110/66] via 10.100.17.1, 00:05:16, FastEthernet0/1
O IA   10.50.2.0/24 [110/66] via 10.100.17.1, 00:05:16, FastEthernet0/1
O IA   10.50.3.0/24 [110/66] via 10.100.17.1, 00:05:16, FastEthernet0/1
O IA   10.50.4.0/24 [110/66] via 10.100.17.1, 00:05:16, FastEthernet0/1
O IA   10.50.5.0/24 [110/66] via 10.100.17.1, 00:05:17, FastEthernet0/1
O IA   10.50.6.0/24 [110/66] via 10.100.17.1, 00:05:17, FastEthernet0/1
O IA   10.50.7.0/24 [110/66] via 10.100.17.1, 00:05:17, FastEthernet0/1
O      10.100.48.0/24 [110/2] via 10.100.78.8, 00:06:35, Port-channel12
O      10.100.10.0/24 [110/2] via 10.100.107.10, 00:06:15, FastEthernet0/19
O      10.100.8.0/24 [110/2] via 10.100.78.8, 00:06:35, Port-channel12
O      10.100.9.0/24 [110/2] via 10.100.79.9, 00:06:25, Port-channel13
```

SW2#show ip route ospf

```
10.0.0.0/8 is variably subnetted, 33 subnets, 3 masks
O      10.255.255.10/32 [110/2] via 10.100.108.10, 00:06:20, Port-channel24
O IA   10.0.0.8/29 [110/65] via 10.100.48.4, 00:05:54, FastEthernet0/4
O      10.255.255.9/32 [110/2] via 10.100.89.9, 00:06:30, FastEthernet0/16
O      10.100.107.0/24 [110/2] via 10.100.108.10, 00:06:20, Port-channel24
O IA   10.255.255.2/32 [110/66] via 10.100.48.4, 00:05:19, FastEthernet0/4
O IA   10.0.0.0/29 [110/66] via 10.100.78.7, 00:05:19, Port-channel12
O      10.255.255.1/32 [110/3] via 10.100.78.7, 00:06:41, Port-channel12
O      10.255.255.7/32 [110/2] via 10.100.78.7, 00:06:41, Port-channel12
O      10.255.255.4/32 [110/2] via 10.100.48.4, 00:06:41, FastEthernet0/4
O IA   10.255.255.5/32 [110/66] via 10.100.48.4, 00:05:19, FastEthernet0/4
O IA   10.20.2.0/24 [110/66] via 10.100.48.4, 00:05:19, FastEthernet0/4
O IA   10.20.3.0/24 [110/66] via 10.100.48.4, 00:05:19, FastEthernet0/4
O IA   10.20.0.0/24 [110/66] via 10.100.48.4, 00:05:19, FastEthernet0/4
O IA   10.20.1.0/24 [110/66] via 10.100.48.4, 00:05:20, FastEthernet0/4
O      10.100.79.0/24 [110/2] via 10.100.89.9, 00:06:32, FastEthernet0/16
O IA   10.50.0.0/24 [110/66] via 10.100.48.4, 00:05:20, FastEthernet0/4
O IA   10.50.1.0/24 [110/66] via 10.100.48.4, 00:05:20, FastEthernet0/4
O IA   10.50.2.0/24 [110/66] via 10.100.48.4, 00:05:20, FastEthernet0/4
O IA   10.50.3.0/24 [110/66] via 10.100.48.4, 00:05:20, FastEthernet0/4
O IA   10.50.4.0/24 [110/66] via 10.100.48.4, 00:05:20, FastEthernet0/4
O IA   10.50.5.0/24 [110/66] via 10.100.48.4, 00:05:20, FastEthernet0/4
O IA   10.50.6.0/24 [110/66] via 10.100.48.4, 00:05:20, FastEthernet0/4
O IA   10.50.7.0/24 [110/66] via 10.100.48.4, 00:05:20, FastEthernet0/4
O      10.100.10.0/24 [110/2] via 10.100.108.10, 00:06:22, Port-channel24
O      10.100.9.0/24 [110/2] via 10.100.89.9, 00:06:32, FastEthernet0/16
O      10.100.7.0/24 [110/2] via 10.100.78.7, 00:06:42, Port-channel12
O      10.100.17.0/24 [110/2] via 10.100.78.7, 00:06:42, Port-channel12
```

SW3#show ip route ospf

```
10.0.0.0/8 is variably subnetted, 33 subnets, 3 masks
O IA 10.255.255.10/32 [110/3] via 10.100.89.8, 00:06:24, FastEthernet0/16
      [110/3] via 10.100.79.7, 00:06:24, Port-channel13
O IA 10.255.255.8/32 [110/2] via 10.100.89.8, 00:06:35, FastEthernet0/16
O IA 10.100.108.0/24 [110/2] via 10.100.89.8, 00:06:35, FastEthernet0/16
O IA 10.0.0.8/29 [110/66] via 10.100.89.8, 00:06:35, FastEthernet0/16
O IA 10.100.107.0/24 [110/2] via 10.100.79.7, 00:06:35, Port-channel13
O IA 10.255.255.2/32 [110/67] via 10.100.89.8, 00:05:22, FastEthernet0/16
      [110/67] via 10.100.79.7, 00:05:22, Port-channel13
O IA 10.0.0.0/29 [110/66] via 10.100.79.7, 00:06:36, Port-channel13
O IA 10.255.255.1/32 [110/3] via 10.100.79.7, 00:06:36, Port-channel13
O IA 10.255.255.7/32 [110/2] via 10.100.79.7, 00:06:36, Port-channel13
O IA 10.255.255.4/32 [110/3] via 10.100.89.8, 00:06:36, FastEthernet0/16
O IA 10.255.255.5/32 [110/67] via 10.100.89.8, 00:05:22, FastEthernet0/16
      [110/67] via 10.100.79.7, 00:05:23, Port-channel13
O IA 10.20.2.0/24 [110/67] via 10.100.89.8, 00:05:23, FastEthernet0/16
      [110/67] via 10.100.79.7, 00:05:23, Port-channel13
O IA 10.20.3.0/24 [110/67] via 10.100.89.8, 00:05:23, FastEthernet0/16
      [110/67] via 10.100.79.7, 00:05:23, Port-channel13
O IA 10.20.0.0/24 [110/67] via 10.100.89.8, 00:05:23, FastEthernet0/16
      [110/67] via 10.100.79.7, 00:05:23, Port-channel13
O IA 10.20.1.0/24 [110/67] via 10.100.89.8, 00:05:23, FastEthernet0/16
      [110/67] via 10.100.79.7, 00:05:23, Port-channel13
O IA 10.100.78.0/24 [110/2] via 10.100.89.8, 00:06:37, FastEthernet0/16
      [110/2] via 10.100.79.7, 00:06:37, Port-channel13
O IA 10.50.0.0/24 [110/67] via 10.100.89.8, 00:05:23, FastEthernet0/16
      [110/67] via 10.100.79.7, 00:05:23, Port-channel13
O IA 10.50.1.0/24 [110/67] via 10.100.89.8, 00:05:23, FastEthernet0/16
      [110/67] via 10.100.79.7, 00:05:24, Port-channel13
O IA 10.50.2.0/24 [110/67] via 10.100.89.8, 00:05:24, FastEthernet0/16
      [110/67] via 10.100.79.7, 00:05:24, Port-channel13
O IA 10.50.3.0/24 [110/67] via 10.100.89.8, 00:05:24, FastEthernet0/16
      [110/67] via 10.100.79.7, 00:05:24, Port-channel13
O IA 10.50.4.0/24 [110/67] via 10.100.89.8, 00:05:24, FastEthernet0/16
      [110/67] via 10.100.79.7, 00:05:24, Port-channel13
O IA 10.50.5.0/24 [110/67] via 10.100.89.8, 00:05:25, FastEthernet0/16
      [110/67] via 10.100.79.7, 00:05:25, Port-channel13
O IA 10.50.6.0/24 [110/67] via 10.100.89.8, 00:05:25, FastEthernet0/16
      [110/67] via 10.100.79.7, 00:05:25, Port-channel13
O IA 10.50.7.0/24 [110/67] via 10.100.89.8, 00:05:25, FastEthernet0/16
      [110/67] via 10.100.79.7, 00:05:25, Port-channel13
O IA 10.100.48.0/24 [110/2] via 10.100.89.8, 00:06:39, FastEthernet0/16
O IA 10.100.10.0/24 [110/3] via 10.100.89.8, 00:06:27, FastEthernet0/16
      [110/3] via 10.100.79.7, 00:06:27, Port-channel13
O IA 10.100.8.0/24 [110/2] via 10.100.89.8, 00:06:39, FastEthernet0/16
O IA 10.100.7.0/24 [110/2] via 10.100.79.7, 00:06:39, Port-channel13
O IA 10.100.17.0/24 [110/2] via 10.100.79.7, 00:06:39, Port-channel13
```

SW4#show ip route ospf

```
10.0.0.0/8 is variably subnetted, 33 subnets, 3 masks
O IA 10.255.255.8/32 [110/2] via 10.100.108.8, 00:06:34, Port-channel24
O IA 10.0.0.8/29 [110/66] via 10.100.108.8, 00:06:34, Port-channel24
O IA 10.255.255.9/32 [110/3] via 10.100.108.8, 00:06:34, Port-channel24
      [110/3] via 10.100.107.7, 00:06:34, FastEthernet0/13
O IA 10.255.255.2/32 [110/67] via 10.100.108.8, 00:05:27, Port-channel24
      [110/67] via 10.100.107.7, 00:05:27, FastEthernet0/13
O IA 10.0.0.0/29 [110/66] via 10.100.107.7, 00:06:34, FastEthernet0/13
O IA 10.255.255.1/32 [110/3] via 10.100.107.7, 00:06:34, FastEthernet0/13
O IA 10.255.255.7/32 [110/2] via 10.100.107.7, 00:06:34, FastEthernet0/13
O IA 10.255.255.4/32 [110/3] via 10.100.108.8, 00:06:34, Port-channel24
O IA 10.255.255.5/32 [110/67] via 10.100.108.8, 00:05:27, Port-channel24
      [110/67] via 10.100.107.7, 00:05:27, FastEthernet0/13
O IA 10.20.2.0/24 [110/67] via 10.100.108.8, 00:05:27, Port-channel24
      [110/67] via 10.100.107.7, 00:05:28, FastEthernet0/13
O IA 10.20.3.0/24 [110/67] via 10.100.108.8, 00:05:28, Port-channel24
      [110/67] via 10.100.107.7, 00:05:28, FastEthernet0/13
O IA 10.20.0.0/24 [110/67] via 10.100.108.8, 00:05:28, Port-channel24
      [110/67] via 10.100.107.7, 00:05:28, FastEthernet0/13
O IA 10.20.1.0/24 [110/67] via 10.100.108.8, 00:05:28, Port-channel24
      [110/67] via 10.100.107.7, 00:05:28, FastEthernet0/13
O IA 10.100.78.0/24 [110/2] via 10.100.108.8, 00:06:36, Port-channel24
      [110/2] via 10.100.107.7, 00:06:36, FastEthernet0/13
O IA 10.100.79.0/24 [110/2] via 10.100.107.7, 00:06:36, FastEthernet0/13
O IA 10.100.89.0/24 [110/2] via 10.100.108.8, 00:06:36, Port-channel24
O IA 10.50.0.0/24 [110/67] via 10.100.108.8, 00:05:28, Port-channel24
      [110/67] via 10.100.107.7, 00:05:28, FastEthernet0/13
O IA 10.50.1.0/24 [110/67] via 10.100.108.8, 00:05:29, Port-channel24
      [110/67] via 10.100.107.7, 00:05:29, FastEthernet0/13
O IA 10.50.2.0/24 [110/67] via 10.100.108.8, 00:05:29, Port-channel24
      [110/67] via 10.100.107.7, 00:05:29, FastEthernet0/13
O IA 10.50.3.0/24 [110/67] via 10.100.108.8, 00:05:29, Port-channel24
      [110/67] via 10.100.107.7, 00:05:29, FastEthernet0/13
O IA 10.50.4.0/24 [110/67] via 10.100.108.8, 00:05:29, Port-channel24
      [110/67] via 10.100.107.7, 00:05:29, FastEthernet0/13
O IA 10.50.5.0/24 [110/67] via 10.100.108.8, 00:05:30, Port-channel24
      [110/67] via 10.100.107.7, 00:05:30, FastEthernet0/13
O IA 10.50.6.0/24 [110/67] via 10.100.108.8, 00:05:30, Port-channel24
      [110/67] via 10.100.107.7, 00:05:30, FastEthernet0/13
O IA 10.50.7.0/24 [110/67] via 10.100.108.8, 00:05:30, Port-channel24
      [110/67] via 10.100.107.7, 00:05:30, FastEthernet0/13
O IA 10.100.48.0/24 [110/2] via 10.100.108.8, 00:06:37, Port-channel24
O IA 10.100.8.0/24 [110/2] via 10.100.108.8, 00:06:37, Port-channel24
O IA 10.100.9.0/24 [110/3] via 10.100.108.8, 00:06:37, Port-channel24
      [110/3] via 10.100.107.7, 00:06:37, FastEthernet0/13
O IA 10.100.7.0/24 [110/2] via 10.100.107.7, 00:06:37, FastEthernet0/13
O IA 10.100.17.0/24 [110/2] via 10.100.107.7, 00:06:37, FastEthernet0/13
```

The OSPF database now consists of Type-1 Router LSAs for each router per area, Type-2 Network LSAs for each DR, and Type-3 Summary Network LSAs for each inter-area route originated by the ABRs.

R1#show ip ospf database

OSPF Router with ID (10.255.255.1) (Process ID 100)

Router Link States (Area 0)

Link ID count	ADV Router	Age	Seq#	Checksum	Link
10.255.255.1	10.255.255.1	443	0x80000002	0x00BA3D	2
10.255.255.4	10.255.255.4	439	0x80000002	0x006844	2
10.255.255.7	10.255.255.7	437	0x80000003	0x00A31C	4
10.255.255.8	10.255.255.8	438	0x80000002	0x00B1C9	4

Net Link States (Area 0)

Link ID	ADV Router	Age	Seq#	Checksum
10.100.17.7	10.255.255.7	444	0x80000001	0x00EA9B
10.100.48.8	10.255.255.8	438	0x80000001	0x00B8A8
10.100.78.8	10.255.255.8	438	0x80000001	0x0097A8

Summary Net Link States (Area 0)

Link ID	ADV Router	Age	Seq#	Checksum
10.0.0.0	10.255.255.1	506	0x80000001	0x00FEEF
10.0.0.0	10.255.255.4	353	0x80000001	0x006F3C
10.0.0.8	10.255.255.1	386	0x80000001	0x003175
10.0.0.8	10.255.255.4	495	0x80000001	0x009C47
10.20.0.0	10.255.255.1	377	0x80000001	0x004290
10.20.0.0	10.255.255.4	354	0x80000001	0x00309F
10.20.1.0	10.255.255.1	377	0x80000001	0x00379A
10.20.1.0	10.255.255.4	354	0x80000001	0x0025A9
10.20.2.0	10.255.255.1	377	0x80000001	0x002CA4
10.20.2.0	10.255.255.4	354	0x80000001	0x001AB3
10.20.3.0	10.255.255.1	377	0x80000001	0x0021AE
10.20.3.0	10.255.255.4	354	0x80000001	0x000FBD
10.50.0.0	10.255.255.1	387	0x80000001	0x00D8DB
10.50.0.0	10.255.255.4	354	0x80000001	0x00C6EA
10.50.1.0	10.255.255.1	387	0x80000001	0x00CDE5
10.50.1.0	10.255.255.4	354	0x80000001	0x00BBF4
10.50.2.0	10.255.255.1	387	0x80000001	0x00C2EF
10.50.2.0	10.255.255.4	354	0x80000001	0x00B0FE
10.50.3.0	10.255.255.1	387	0x80000001	0x00B7F9
10.50.3.0	10.255.255.4	355	0x80000001	0x00A509
10.50.4.0	10.255.255.1	388	0x80000001	0x00AC04
10.50.4.0	10.255.255.4	355	0x80000001	0x009A13
10.50.5.0	10.255.255.1	388	0x80000001	0x00A10E
10.50.5.0	10.255.255.4	355	0x80000001	0x008F1D
10.50.6.0	10.255.255.1	388	0x80000001	0x009618
10.50.6.0	10.255.255.4	355	0x80000001	0x008427
10.50.7.0	10.255.255.1	388	0x80000001	0x008B22
10.50.7.0	10.255.255.4	355	0x80000001	0x007931

10.100.9.0	10.255.255.7	421	0x80000001	0x007E34
10.100.9.0	10.255.255.8	426	0x80000001	0x007839
10.100.10.0	10.255.255.7	421	0x80000001	0x00733E
10.100.10.0	10.255.255.8	416	0x80000001	0x006D43
10.100.79.0	10.255.255.7	482	0x80000001	0x006FFD
10.100.79.0	10.255.255.8	426	0x80000001	0x0073F7
10.100.89.0	10.255.255.7	423	0x80000001	0x000B57
10.100.89.0	10.255.255.8	477	0x80000001	0x00FA67
10.100.107.0	10.255.255.7	483	0x80000001	0x003A17
10.100.107.0	10.255.255.8	417	0x80000001	0x003E11
10.100.108.0	10.255.255.7	423	0x80000001	0x003916
10.100.108.0	10.255.255.8	477	0x80000001	0x002926
10.255.255.2	10.255.255.1	379	0x80000001	0x001FC5
10.255.255.2	10.255.255.4	356	0x80000001	0x000DD4
10.255.255.5	10.255.255.1	389	0x80000001	0x0001E0
10.255.255.5	10.255.255.4	357	0x80000001	0x00EEEF
10.255.255.9	10.255.255.7	423	0x80000001	0x003CDA
10.255.255.9	10.255.255.8	427	0x80000001	0x0036DF
10.255.255.10	10.255.255.7	423	0x80000001	0x0032E3
10.255.255.10	10.255.255.8	417	0x80000001	0x002CE8

Router Link States (Area 1245)

Link ID count	ADV Router	Age	Seq#	Checksum	Link
10.255.255.1	10.255.255.1	394	0x80000002	0x003F86	1
10.255.255.2	10.255.255.2	360	0x80000003	0x00BAB1	7
10.255.255.4	10.255.255.4	360	0x80000002	0x00CFDF	1
10.255.255.5	10.255.255.5	360	0x80000003	0x00A5F7	11

Net Link States (Area 1245)

Link ID	ADV Router	Age	Seq#	Checksum
10.0.0.1	10.255.255.1	390	0x80000002	0x004EB1
10.0.0.9	10.255.255.4	361	0x80000001	0x0018DA

Summary Net Link States (Area 1245)

Link ID	ADV Router	Age	Seq#	Checksum
10.100.7.0	10.255.255.1	443	0x80000001	0x00B802
10.100.7.0	10.255.255.4	427	0x80000001	0x00B006
10.100.8.0	10.255.255.1	433	0x80000001	0x00B701
10.100.8.0	10.255.255.4	437	0x80000001	0x009B1B
10.100.9.0	10.255.255.1	418	0x80000002	0x00AA0C
10.100.9.0	10.255.255.4	427	0x80000001	0x009A1A
10.100.10.0	10.255.255.1	424	0x80000001	0x00A115
10.100.10.0	10.255.255.4	418	0x80000002	0x008D25
10.100.17.0	10.255.255.1	512	0x80000001	0x004071
10.100.17.0	10.255.255.4	428	0x80000001	0x00426A
10.100.48.0	10.255.255.1	434	0x80000001	0x00FD92
10.100.48.0	10.255.255.4	498	0x80000001	0x00D7B7
10.100.78.0	10.255.255.1	444	0x80000001	0x00A8CA
10.100.78.0	10.255.255.4	438	0x80000001	0x0096D9
10.100.79.0	10.255.255.1	444	0x80000001	0x009DD4
10.100.79.0	10.255.255.4	428	0x80000001	0x0095D8
10.100.89.0	10.255.255.1	434	0x80000001	0x00392E
10.100.89.0	10.255.255.4	438	0x80000001	0x001D48

10.100.107.0	10.255.255.1	444	0x80000001	0x0068ED
10.100.107.0	10.255.255.4	428	0x80000001	0x0060F1
10.100.108.0	10.255.255.1	434	0x80000001	0x0067EC
10.100.108.0	10.255.255.4	438	0x80000001	0x004B07
10.255.255.1	10.255.255.1	513	0x80000001	0x00A67F
10.255.255.1	10.255.255.4	430	0x80000001	0x00B26D
10.255.255.4	10.255.255.1	435	0x80000001	0x00A679
10.255.255.4	10.255.255.4	500	0x80000001	0x0076A9
10.255.255.7	10.255.255.1	445	0x80000001	0x0074AA
10.255.255.7	10.255.255.4	430	0x80000001	0x006CAE
10.255.255.8	10.255.255.1	435	0x80000001	0x0074A8
10.255.255.8	10.255.255.4	440	0x80000001	0x0058C2
10.255.255.9	10.255.255.1	420	0x80000002	0x0068B2
10.255.255.9	10.255.255.4	430	0x80000001	0x0058C0
10.255.255.10	10.255.255.1	425	0x80000001	0x0060BA
10.255.255.10	10.255.255.4	420	0x80000002	0x004CCA

Different routers now have different views of the OSPF database based on their area assignments. Note that R2's database is much smaller than R1, who has links in both area 0 and area 1245. R2's view includes the Type-1 Router LSAs about R1, R2, R4, and R5 who are in area 1245, Type-2 Network LSAs about the DRs (R1 and R4), and Type-3 Summary Network LSAs about the inter-area routes originated by the ABRs (R1 and R4).

R2#show ip ospf database

OSPF Router with ID (10.255.255.2) (Process ID 100)

Router Link States (Area 1245)

Link ID count	ADV Router	Age	Seq#	Checksum	Link
10.255.255.1	10.255.255.1	406	0x80000002	0x003F86	1
10.255.255.2	10.255.255.2	369	0x80000003	0x00BAB1	7
10.255.255.4	10.255.255.4	370	0x80000002	0x00CFDF	1
10.255.255.5	10.255.255.5	371	0x80000003	0x00A5F7	11

Net Link States (Area 1245)

Link ID	ADV Router	Age	Seq#	Checksum
10.0.0.1	10.255.255.1	401	0x80000002	0x004EB1
10.0.0.9	10.255.255.4	370	0x80000001	0x0018DA

Summary Net Link States (Area 1245)

Link ID	ADV Router	Age	Seq#	Checksum
10.100.7.0	10.255.255.1	453	0x80000001	0x00B802
10.100.7.0	10.255.255.4	437	0x80000001	0x00B006
10.100.8.0	10.255.255.1	443	0x80000001	0x00B701
10.100.8.0	10.255.255.4	447	0x80000001	0x009B1B
10.100.9.0	10.255.255.1	429	0x80000002	0x00AA0C
10.100.9.0	10.255.255.4	438	0x80000001	0x009A1A
10.100.10.0	10.255.255.1	434	0x80000001	0x00A115
10.100.10.0	10.255.255.4	428	0x80000002	0x008D25

10.100.17.0	10.255.255.1	522	0x80000001	0x004071
10.100.17.0	10.255.255.4	438	0x80000001	0x00426A
10.100.48.0	10.255.255.1	444	0x80000001	0x00FD92
10.100.48.0	10.255.255.4	508	0x80000001	0x00D7B7
10.100.78.0	10.255.255.1	454	0x80000001	0x00A8CA
10.100.78.0	10.255.255.4	448	0x80000001	0x0096D9
10.100.79.0	10.255.255.1	454	0x80000001	0x009DD4
10.100.79.0	10.255.255.4	438	0x80000001	0x0095D8
10.100.89.0	10.255.255.1	444	0x80000001	0x00392E
10.100.89.0	10.255.255.4	448	0x80000001	0x001D48
10.100.107.0	10.255.255.1	454	0x80000001	0x0068ED
10.100.107.0	10.255.255.4	439	0x80000001	0x0060F1
10.100.108.0	10.255.255.1	446	0x80000001	0x0067EC
10.100.108.0	10.255.255.4	449	0x80000001	0x004B07
10.255.255.1	10.255.255.1	524	0x80000001	0x00A67F
10.255.255.1	10.255.255.4	439	0x80000001	0x00B26D
10.255.255.4	10.255.255.1	446	0x80000001	0x00A679
10.255.255.4	10.255.255.4	509	0x80000001	0x0076A9
10.255.255.7	10.255.255.1	456	0x80000001	0x0074AA
10.255.255.7	10.255.255.4	439	0x80000001	0x006CAE
10.255.255.8	10.255.255.1	446	0x80000001	0x0074A8
10.255.255.8	10.255.255.4	449	0x80000001	0x0058C2
10.255.255.9	10.255.255.1	431	0x80000002	0x0068B2
10.255.255.9	10.255.255.4	439	0x80000001	0x0058C0
10.255.255.10	10.255.255.1	436	0x80000001	0x0060BA
10.255.255.10	10.255.255.4	429	0x80000002	0x004CCA

3.3 OSPF Optimization

```
R1#
interface Serial0/0
  ip ospf network point-to-multipoint
  ip ospf dead-interval minimal hello-multiplier 5
!
interface FastEthernet0/0
  ip ospf network point-to-point

R2#
interface Serial0/0.201 point-to-point
  ip ospf network point-to-multipoint
  ip ospf dead-interval minimal hello-multiplier 5
!
interface Serial0/0.204 point-to-point
  ip ospf network point-to-multipoint
  ip ospf dead-interval minimal hello-multiplier 5

R4#
interface Serial0/0/0
  ip ospf network point-to-multipoint
  ip ospf dead-interval minimal hello-multiplier 5
!
interface FastEthernet0/0
  ip ospf network point-to-point

R5#
interface Serial0/0/0.501 point-to-point
  ip ospf network point-to-multipoint
  ip ospf dead-interval minimal hello-multiplier 5
!
interface Serial0/0/0.504 point-to-point
  ip ospf network point-to-multipoint
  ip ospf dead-interval minimal hello-multiplier 5

SW1#
interface FastEthernet0/1
  ip ospf network point-to-point
!
interface FastEthernet0/19
  ip ospf network point-to-point
!
interface Port-channel12
  ip ospf network point-to-point
!
interface Port-channel13
  ip ospf network point-to-point

SW2#
interface FastEthernet0/4
  ip ospf network point-to-point
!
interface FastEthernet0/16
  ip ospf network point-to-point
!
interface Port-channel12
```

```

ip ospf network point-to-point
!
interface Port-channel24
ip ospf network point-to-point

SW3#
interface FastEthernet0/16
ip ospf network point-to-point
!
interface Port-channel13
ip ospf network point-to-point

SW4#
interface FastEthernet0/13
ip ospf network point-to-point
!
interface Port-channel24
ip ospf network point-to-point

```

 **Note**

With the previous configuration, the Frame Relay links run network type non-broadcast. This means that a DR/BDR election occurs, and hellos are unicast to manually defined neighbors.

```

R1#show ip ospf interface Serial0/0
Serial0/0 is up, line protocol is up
Internet Address 10.0.0.1/29, Area 1245
Process ID 100, Router ID 10.255.255.1, Network Type NON_BROADCAST,
Cost: 64
Enabled by interface config, including secondary ip addresses
Transmit Delay is 1 sec, State DR, Priority 1
Designated Router (ID) 10.255.255.1, Interface address 10.0.0.1
No backup designated router on this network
Timer intervals configured, Hello 30, Dead 120, Wait 120, Retransmit 5
oob-resync timeout 120
Hello due in 00:00:25
Supports Link-local Signaling (LLS)
Index 1/3, flood queue length 0
Next 0x0(0)/0x0(0)
Last flood scan length is 1, maximum is 31
Last flood scan time is 0 msec, maximum is 4 msec
Neighbor Count is 2, Adjacent neighbor count is 2
Adjacent with neighbor 10.255.255.5
Adjacent with neighbor 10.255.255.2
Suppress hello for 0 neighbor(s)

```

For point-to-point Ethernet links with only two neighbors, it is inefficient to also generate a Type-2 Network LSA for the DR.

R1#show ip ospf database network

OSPF Router with ID (10.255.255.1) (Process ID 100)

Net Link States (Area 0)

Routing Bit Set on this LSA

LS age: 821

Options: (No TOS-capability, DC)

LS Type: Network Links

Link State ID: 10.100.17.7 (address of Designated Router)

Advertising Router: 10.255.255.7

LS Seq Number: 80000001

Checksum: 0xEA9B

Length: 32

Network Mask: /24

Attached Router: 10.255.255.7

Attached Router: 10.255.255.1

Routing Bit Set on this LSA

LS age: 816

Options: (No TOS-capability, DC)

LS Type: Network Links

Link State ID: 10.100.48.8 (address of Designated Router)

Advertising Router: 10.255.255.8

LS Seq Number: 80000001

Checksum: 0xB8A8

Length: 32

Network Mask: /24

Attached Router: 10.255.255.8

Attached Router: 10.255.255.4

Routing Bit Set on this LSA

LS age: 816

Options: (No TOS-capability, DC)

LS Type: Network Links

Link State ID: 10.100.78.8 (address of Designated Router)

Advertising Router: 10.255.255.8

LS Seq Number: 80000001

Checksum: 0x97A8

Length: 32

Network Mask: /24

Attached Router: 10.255.255.8

Attached Router: 10.255.255.7

Net Link States (Area 1245)

Routing Bit Set on this LSA

LS age: 764

Options: (No TOS-capability, DC)

LS Type: Network Links

```

Link State ID: 10.0.0.1 (address of Designated Router)
Advertising Router: 10.255.255.1
LS Seq Number: 80000002
Checksum: 0x4EB1
Length: 36
Network Mask: /29
    Attached Router: 10.255.255.1
    Attached Router: 10.255.255.5
    Attached Router: 10.255.255.2
    
```

```

Routing Bit Set on this LSA
LS age: 735
Options: (No TOS-capability, DC)
LS Type: Network Links
    
```

```

Link State ID: 10.0.0.9 (address of Designated Router)
Advertising Router: 10.255.255.4
LS Seq Number: 80000001
Checksum: 0x18DA
Length: 36
Network Mask: /29
    Attached Router: 10.255.255.4
    Attached Router: 10.255.255.2
    Attached Router: 10.255.255.5
    
```

With network type point-to-multipoint, no DR/BDR election occurs, and neighbors are automatically discovered and maintained through multicasts.

```

R1#show ip ospf interface Serial0/0
Serial0/0 is up, line protocol is up
  Internet Address 10.0.0.1/29, Area 1245
  Process ID 100, Router ID 10.255.255.1, Network Type
  POINT_TO_MULTIPPOINT, Cost: 64
  Enabled by interface config, including secondary ip addresses
  Transmit Delay is 1 sec, State POINT_TO_MULTIPPOINT,
  Timer intervals configured, Hello 200 msec, Dead 1, Wait 1,
  Retransmit 5
    oob-resync timeout 40
    Hello due in 72 msec
  Supports Link-local Signaling (LLS)
  Index 1/3, flood queue length 0
  Next 0x0(0)/0x0(0)
  Last flood scan length is 1, maximum is 31
  Last flood scan time is 0 msec, maximum is 4 msec
  Neighbor Count is 2, Adjacent neighbor count is 2
    Adjacent with neighbor 10.255.255.2
    Adjacent with neighbor 10.255.255.5
  Suppress hello for 0 neighbor(s)
    
```

The null field after the FULL neighbor state indicates that no DR/BDR election has occurred.

R1#show ip ospf neighbor

Neighbor ID	Pri	State	Dead Time	Address	Interface
10.255.255.7	0	FULL/ -	00:00:38	10.100.17.7	FastEthernet0/0
10.255.255.2	0	FULL/ -	835 msec	10.0.0.2	Serial0/0
10.255.255.5	0	FULL/ -	988 msec	10.0.0.3	Serial0/0

After modifying the Ethernet links to point-to-point network type, Type-2 LSAs no longer are required in the OSPF database.

R1#show ip ospf database

OSPF Router with ID (10.255.255.1) (Process ID 100)

Router Link States (Area 0)

Link ID count	ADV Router	Age	Seq#	Checksum	Link
10.255.255.1	10.255.255.1	289	0x80000003	0x002CB0	3
10.255.255.4	10.255.255.4	273	0x80000003	0x00375A	3
10.255.255.7	10.255.255.7	241	0x80000006	0x007B13	6
10.255.255.8	10.255.255.8	242	0x80000004	0x0062E7	6

Summary Net Link States (Area 0)

Link ID	ADV Router	Age	Seq#	Checksum
10.0.0.1	10.255.255.1	560	0x80000001	0x009C8A
10.0.0.1	10.255.255.4	267	0x80000001	0x008F14
10.0.0.2	10.255.255.1	274	0x80000001	0x0015D0
10.0.0.2	10.255.255.4	267	0x80000001	0x0003DF
10.0.0.3	10.255.255.1	254	0x80000001	0x000BD9
10.0.0.3	10.255.255.4	257	0x80000001	0x00F8E8
10.0.0.9	10.255.255.1	264	0x80000001	0x00514D
10.0.0.9	10.255.255.4	268	0x80000001	0x003AE1
10.0.0.10	10.255.255.1	275	0x80000001	0x00C419
10.0.0.10	10.255.255.4	268	0x80000001	0x00B228
10.0.0.11	10.255.255.1	255	0x80000001	0x00BA22
10.0.0.11	10.255.255.4	258	0x80000001	0x00A831
10.20.0.0	10.255.255.1	276	0x80000001	0x004290
10.20.0.0	10.255.255.4	268	0x80000001	0x00309F
10.20.1.0	10.255.255.1	276	0x80000001	0x00379A
10.20.1.0	10.255.255.4	268	0x80000001	0x0025A9
10.20.2.0	10.255.255.1	276	0x80000001	0x002CA4
10.20.2.0	10.255.255.4	268	0x80000001	0x001AB3
10.20.3.0	10.255.255.1	276	0x80000001	0x0021AE
10.20.3.0	10.255.255.4	268	0x80000001	0x000FBD
10.50.0.0	10.255.255.1	255	0x80000001	0x00D8DB
10.50.0.0	10.255.255.4	248	0x80000003	0x00C2EC
10.50.1.0	10.255.255.1	255	0x80000001	0x00CDE5
10.50.1.0	10.255.255.4	249	0x80000003	0x00B7F6

10.50.2.0	10.255.255.1	257	0x80000001	0x00C2EF
10.50.2.0	10.255.255.4	249	0x80000003	0x00AC01
10.50.3.0	10.255.255.1	257	0x80000001	0x00B7F9
10.50.3.0	10.255.255.4	249	0x80000003	0x00A10B
10.50.4.0	10.255.255.1	257	0x80000001	0x00AC04
10.50.4.0	10.255.255.4	249	0x80000003	0x009615
10.50.5.0	10.255.255.1	257	0x80000001	0x00A10E
10.50.5.0	10.255.255.4	249	0x80000003	0x008B1F
10.50.6.0	10.255.255.1	257	0x80000001	0x009618
10.50.6.0	10.255.255.4	249	0x80000003	0x008029
10.50.7.0	10.255.255.1	257	0x80000001	0x008B22
10.50.7.0	10.255.255.4	249	0x80000003	0x007533
10.100.9.0	10.255.255.7	232	0x80000001	0x007E34
10.100.9.0	10.255.255.8	228	0x80000003	0x00743B
10.100.10.0	10.255.255.7	232	0x80000001	0x00733E
10.100.10.0	10.255.255.8	229	0x80000003	0x006945
10.100.79.0	10.255.255.7	1482	0x80000001	0x006FFD
10.100.79.0	10.255.255.8	229	0x80000003	0x006FF9
10.100.89.0	10.255.255.7	233	0x80000001	0x000B57
10.100.89.0	10.255.255.8	1476	0x80000001	0x00FA67
10.100.107.0	10.255.255.7	1482	0x80000001	0x003A17
10.100.107.0	10.255.255.8	229	0x80000003	0x003A13
10.100.108.0	10.255.255.7	233	0x80000001	0x003916
10.100.108.0	10.255.255.8	1476	0x80000001	0x002926
10.255.255.2	10.255.255.1	278	0x80000001	0x001FC5
10.255.255.2	10.255.255.4	270	0x80000001	0x000DD4
10.255.255.5	10.255.255.1	258	0x80000001	0x0001E0
10.255.255.5	10.255.255.4	251	0x80000003	0x00EAF1
10.255.255.9	10.255.255.7	233	0x80000001	0x003CDA
10.255.255.9	10.255.255.8	229	0x80000003	0x0032E1
10.255.255.10	10.255.255.7	235	0x80000001	0x0032E3
10.255.255.10	10.255.255.8	230	0x80000003	0x0028EA

Router Link States (Area 1245)

Link ID count	ADV Router	Age	Seq#	Checksum	Link
10.255.255.1	10.255.255.1	262	0x80000005	0x00102F	3
10.255.255.2	10.255.255.2	275	0x80000009	0x0084A8	9
10.255.255.4	10.255.255.4	264	0x80000005	0x0032EE	3
10.255.255.5	10.255.255.5	263	0x80000009	0x00E07B	13

Summary Net Link States (Area 1245)

Link ID	ADV Router	Age	Seq#	Checksum
10.100.7.0	10.255.255.1	249	0x80000001	0x00B802
10.100.7.0	10.255.255.4	240	0x80000001	0x00B006
10.100.8.0	10.255.255.1	239	0x80000001	0x00B701
10.100.8.0	10.255.255.4	250	0x80000001	0x009B1B
10.100.9.0	10.255.255.1	234	0x80000001	0x00AC0B
10.100.9.0	10.255.255.4	230	0x80000003	0x00961C
10.100.10.0	10.255.255.1	235	0x80000001	0x00A115
10.100.10.0	10.255.255.4	231	0x80000003	0x008B26
10.100.17.0	10.255.255.1	285	0x80000003	0x003C73
10.100.17.0	10.255.255.4	241	0x80000001	0x00426A
10.100.48.0	10.255.255.1	240	0x80000001	0x00FD92
10.100.48.0	10.255.255.4	1497	0x80000001	0x00D7B7

10.100.78.0	10.255.255.1	250	0x80000001	0x00A8CA
10.100.78.0	10.255.255.4	252	0x80000001	0x0096D9
10.100.79.0	10.255.255.1	250	0x80000001	0x009DD4
10.100.79.0	10.255.255.4	251	0x80000001	0x0095D8
10.100.89.0	10.255.255.1	240	0x80000001	0x00392E
10.100.89.0	10.255.255.4	251	0x80000001	0x001D48
10.100.107.0	10.255.255.1	250	0x80000001	0x0068ED
10.100.107.0	10.255.255.4	251	0x80000001	0x0060F1
10.100.108.0	10.255.255.1	240	0x80000001	0x0067EC
10.100.108.0	10.255.255.4	251	0x80000001	0x004B07
10.255.255.1	10.255.255.1	1512	0x80000001	0x00A67F
10.255.255.1	10.255.255.4	243	0x80000001	0x00B26D
10.255.255.4	10.255.255.1	241	0x80000001	0x00A679
10.255.255.4	10.255.255.4	1499	0x80000001	0x0076A9
10.255.255.7	10.255.255.1	251	0x80000001	0x0074AA
10.255.255.7	10.255.255.4	243	0x80000001	0x006CAE
10.255.255.8	10.255.255.1	241	0x80000001	0x0074A8
10.255.255.8	10.255.255.4	253	0x80000001	0x0058C2
10.255.255.9	10.255.255.1	231	0x80000002	0x0068B2
10.255.255.9	10.255.255.4	233	0x80000003	0x0054C2
10.255.255.10	10.255.255.1	236	0x80000001	0x0060BA
10.255.255.10	10.255.255.4	233	0x80000003	0x004ACB

An additional property of network type point-to-multipoint is that the endpoints of the link are advertised as /32 host routes, and no advertisement occurs for the transit network itself.

```
SW1#show ip route ospf
```

```
10.0.0.0/8 is variably subnetted, 37 subnets, 2 masks
O      10.255.255.10/32 [110/2] via 10.100.107.10, 00:04:26, FastEthernet0/19
O IA   10.0.0.10/32 [110/65] via 10.100.17.1, 00:04:26, FastEthernet0/1
O IA   10.0.0.11/32 [110/65] via 10.100.17.1, 00:04:26, FastEthernet0/1
O      10.255.255.8/32 [110/2] via 10.100.78.8, 00:04:36, Port-channel12
O      10.100.108.0/24 [110/2] via 10.100.107.10, 00:04:26, FastEthernet0/19
O      10.255.255.9/32 [110/2] via 10.100.79.9, 00:04:26, Port-channel13
O IA   10.0.0.9/32 [110/2] via 10.100.78.8, 00:04:27, Port-channel12
O IA   10.255.255.2/32 [110/66] via 10.100.17.1, 00:04:27, FastEthernet0/1
O IA   10.0.0.2/32 [110/65] via 10.100.17.1, 00:04:27, FastEthernet0/1
O IA   10.0.0.3/32 [110/65] via 10.100.17.1, 00:04:27, FastEthernet0/1
O      10.255.255.1/32 [110/2] via 10.100.17.1, 00:04:37, FastEthernet0/1
O IA   10.0.0.1/32 [110/1] via 10.100.17.1, 00:04:27, FastEthernet0/1
O      10.255.255.4/32 [110/3] via 10.100.78.8, 00:04:37, Port-channel12
O IA   10.255.255.5/32 [110/66] via 10.100.17.1, 00:04:27, FastEthernet0/1
O IA   10.20.2.0/24 [110/66] via 10.100.17.1, 00:04:27, FastEthernet0/1
O IA   10.20.3.0/24 [110/66] via 10.100.17.1, 00:04:27, FastEthernet0/1
O IA   10.20.0.0/24 [110/66] via 10.100.17.1, 00:04:27, FastEthernet0/1
O IA   10.20.1.0/24 [110/66] via 10.100.17.1, 00:04:27, FastEthernet0/1
O      10.100.89.0/24 [110/2] via 10.100.79.9, 00:04:27, Port-channel13
O IA   10.50.0.0/24 [110/66] via 10.100.17.1, 00:04:27, FastEthernet0/1
O IA   10.50.1.0/24 [110/66] via 10.100.17.1, 00:04:28, FastEthernet0/1
O IA   10.50.2.0/24 [110/66] via 10.100.17.1, 00:04:28, FastEthernet0/1
O IA   10.50.3.0/24 [110/66] via 10.100.17.1, 00:04:28, FastEthernet0/1
O IA   10.50.4.0/24 [110/66] via 10.100.17.1, 00:04:28, FastEthernet0/1
O IA   10.50.5.0/24 [110/66] via 10.100.17.1, 00:04:28, FastEthernet0/1
O IA   10.50.6.0/24 [110/66] via 10.100.17.1, 00:04:28, FastEthernet0/1
O IA   10.50.7.0/24 [110/66] via 10.100.17.1, 00:04:28, FastEthernet0/1
O      10.100.48.0/24 [110/2] via 10.100.78.8, 00:04:39, Port-channel12
O      10.100.10.0/24 [110/2] via 10.100.107.10, 00:04:29, FastEthernet0/19
O      10.100.8.0/24 [110/2] via 10.100.78.8, 00:04:39, Port-channel12
O      10.100.9.0/24 [110/2] via 10.100.79.9, 00:04:29, Port-channel13
```

3.4 OSPF Security

```
R1#
interface FastEthernet0/0
  ip ospf authentication message-digest
  ip ospf message-digest-key 1 md5 DBMIMD5
!
interface Serial0/0
  ip ospf authentication
  ip ospf authentication-key DBMIPASS

R2#
interface Serial0/0.201 point-to-point
  ip ospf authentication-key DBMIPASS
!
interface Serial0/0.204 point-to-point
  ip ospf authentication-key DBMIPASS
!
router ospf 100
  area 1245 authentication
  passive-interface default
  no passive-interface Serial0/0.201
  no passive-interface Serial0/0.204

R4#
interface FastEthernet0/0
  ip ospf authentication message-digest
  ip ospf message-digest-key 1 md5 DBMIMD5
!
interface Serial0/0/0
  ip ospf authentication
  ip ospf authentication-key DBMIPASS

R5#
interface Serial0/0/0.501 point-to-point
  ip ospf authentication-key DBMIPASS
!
interface Serial0/0/0.504 point-to-point
  ip ospf authentication-key DBMIPASS
!
router ospf 100
  area 1245 authentication
  passive-interface default
  no passive-interface Serial0/0/0.501
  no passive-interface Serial0/0/0.504

SW1#
interface Port-channel12
  ip ospf message-digest-key 1 md5 DBMIMD5
!
interface Port-channel13
  ip ospf authentication message-digest
  ip ospf message-digest-key 1 md5 DBMIMD5
!
interface FastEthernet0/1
  ip ospf message-digest-key 1 md5 DBMIMD5
!
```

```
interface FastEthernet0/19
  ip ospf authentication message-digest
  ip ospf message-digest-key 1 md5 DBMIMD5
!
router ospf 100
  area 0 authentication message-digest

SW2#
interface Port-channel12
  ip ospf message-digest-key 1 md5 DBMIMD5
!
interface Port-channel24
  ip ospf authentication message-digest
  ip ospf message-digest-key 1 md5 DBMIMD5
!
interface FastEthernet0/4
  ip ospf message-digest-key 1 md5 DBMIMD5
!
interface FastEthernet0/16
  ip ospf authentication message-digest
  ip ospf message-digest-key 1 md5 DBMIMD5
!
router ospf 100
  area 0 authentication message-digest

SW3#
interface Port-channel13
  ip ospf authentication message-digest
  ip ospf message-digest-key 1 md5 DBMIMD5
!
interface FastEthernet0/16
  ip ospf authentication message-digest
  ip ospf message-digest-key 1 md5 DBMIMD5
!
router ospf 100
  passive-interface Vlan9

SW4#
interface Port-channel24
  ip ospf authentication message-digest
  ip ospf message-digest-key 1 md5 DBMIMD5
!
interface FastEthernet0/13
  ip ospf authentication message-digest
  ip ospf message-digest-key 1 md5 DBMIMD5
!
router ospf 100
  passive-interface Vlan10
```

 **Note**

Passive interfaces for OSPF, like in EIGRP, stop the sending of hello packets out the interface and prevent an adjacency from occurring. They do not however stop the interface from being advertised inside of the Type-1 Router LSA.

R2#show ip protocols

```
Routing Protocol is "ospf 100"
  Outgoing update filter list for all interfaces is not set
  Incoming update filter list for all interfaces is not set
  Router ID 10.255.255.2
  Number of areas in this router is 1. 0 normal 0 stub 1 nssa
  Maximum path: 4
  Routing for Networks:
    0.0.0.0 255.255.255.255 area 1245
  Reference bandwidth unit is 100 mbps
  Passive Interface(s):
    FastEthernet0/0
    FastEthernet0/0.200
    FastEthernet0/0.201
    FastEthernet0/0.202
    FastEthernet0/0.203
    Serial0/0
    Serial0/1
    Loopback0
    VoIP-Null0
  Routing Information Sources:
    Gateway          Distance      Last Update
    10.255.255.1      110          00:02:32
    10.255.255.4      110          00:02:32
    10.255.255.5      110          00:02:32
  Distance: (default is 110)
```

OSPF authentication can be enabled for all interface in the area under the process, or on a link by link basis. In either case, the authentication key (password) is always configured at the link level. If adjacency has occurred, authentication can be assumed to be successful.

R1#show ip ospf interface

```
FastEthernet0/0 is up, line protocol is up
  Internet Address 10.100.17.1/24, Area 0
  Process ID 100, Router ID 10.255.255.1, Network Type POINT_TO_POINT, Cost: 1
  Enabled by interface config, including secondary ip addresses
  Transmit Delay is 1 sec, State POINT_TO_POINT,
  Timer intervals configured, Hello 10, Dead 40, Wait 40, Retransmit 5
    oob-resync timeout 40
    Hello due in 00:00:00
  Supports Link-local Signaling (LLS)
  Index 2/2, flood queue length 0
  Next 0x0(0)/0x0(0)
  Last flood scan length is 1, maximum is 19
  Last flood scan time is 0 msec, maximum is 4 msec
  Neighbor Count is 1, Adjacent neighbor count is 1
    Adjacent with neighbor 10.255.255.7
  Suppress hello for 0 neighbor(s)
  Message digest authentication enabled
  Youngest key id is 1
Loopback0 is up, line protocol is up
  Internet Address 10.255.255.1/32, Area 0
  Process ID 100, Router ID 10.255.255.1, Network Type LOOPBACK, Cost: 1
  Enabled by interface config, including secondary ip addresses
  Loopback interface is treated as a stub Host
Serial10/0 is up, line protocol is up
  Internet Address 10.0.0.1/29, Area 1245
  Process ID 100, Router ID 10.255.255.1, Network Type POINT_TO_MULTIPOINT,
Cost: 64
  Enabled by interface config, including secondary ip addresses
  Transmit Delay is 1 sec, State POINT_TO_MULTIPOINT,
  Timer intervals configured, Hello 200 msec, Dead 1, Wait 1, Retransmit 5
    oob-resync timeout 40
    Hello due in 135 msec
  Supports Link-local Signaling (LLS)
  Index 1/3, flood queue length 0
  Next 0x0(0)/0x0(0)
  Last flood scan length is 1, maximum is 31
  Last flood scan time is 0 msec, maximum is 5 msec
  Neighbor Count is 2, Adjacent neighbor count is 2
    Adjacent with neighbor 10.255.255.2
    Adjacent with neighbor 10.255.255.5
  Suppress hello for 0 neighbor(s)
  Simple password authentication enabled
```

3.5 OSPF Redundancy

Note

OSPF Virtual-Links are area 0 interface, therefore the authentication key must be configured on them since authentication was already previously enabled.

```
SW1#
router ospf 100
 area 7810 virtual-link 10.255.255.8 message-digest-key 1 md5 DBMIMD5
```

```
SW2#
router ospf 100
 area 7810 virtual-link 10.255.255.7 message-digest-key 1 md5 DBMIMD5
```

Note

Prior to the Virtual-Link being configured, SW1 and SW2 lose connectivity to each other when the layer 3 port-channel between them is down due to segmented area 0.

```
SW1#config t
Enter configuration commands, one per line.  End with CNTL/Z.
SW1(config)#interface range Fa0/13 - 15
SW1(config-if-range)#shutdown
SW1(config-if-range)#end
SW1#
*Mar  1 22:00:59.131: %LINEPROTO-5-UPDOWN: Line protocol on Interface
Port-channel12, changed state to down
*Mar  1 22:00:59.240: %SYS-5-CONFIG_I: Configured from console by
console
*Mar  1 22:01:00.171: %LINK-5-CHANGED: Interface FastEthernet0/13,
changed state to administratively down
*Mar  1 22:01:00.171: %LINK-5-CHANGED: Interface FastEthernet0/14,
changed state to administratively down
*Mar  1 22:01:00.171: %LINK-5-CHANGED: Interface FastEthernet0/15,
changed state to administratively down
*Mar  1 22:01:00.171: %LINK-3-UPDOWN: Interface Port-channel12, changed
state to down
*Mar  1 22:01:00.171: %OSPF-5-ADJCHG: Process 100, Nbr 10.255.255.8 on
Port-channel12 from FULL to DOWN, Neighbor Down: Interface down or
detached
*Mar  1 22:01:01.178: %LINEPROTO-5-UPDOWN: Line protocol on Interface
FastEthernet0/13, changed state to down
*Mar  1 22:01:01.178: %LINEPROTO-5-UPDOWN: Line protocol on Interface
FastEthernet0/14, changed state to down
*Mar  1 22:01:01.178: %LINEPROTO-5-UPDOWN: Line protocol on Interface
FastEthernet0/15, changed state to down
```



```
SW1#show ip route 10.100.8.0
% Subnet not in table
```

SW1 still has the LSA for the network 10.100.8.0/24, but cannot compute SPF to reach it because the router 10.255.255.8 (SW2) is unreachable.

```
SW1#show ip ospf database summary 10.100.8.0
```

```
OSPF Router with ID (10.255.255.7) (Process ID 100)
```

```
Summary Net Link States (Area 789)
```

```
LS age: 520
Options: (No TOS-capability, DC, Upward)
LS Type: Summary Links(Network)
Link State ID: 10.100.8.0 (summary Network Number)
Advertising Router: 10.255.255.8
LS Seq Number: 80000002
Checksum: 0x773B
Length: 28
Network Mask: /24
TOS: 0 Metric: 1
```

```
Summary Net Link States (Area 7810)
```

```
LS age: 520
Options: (No TOS-capability, DC, Upward)
LS Type: Summary Links(Network)
Link State ID: 10.100.8.0 (summary Network Number)
Advertising Router: 10.255.255.8
LS Seq Number: 80000002
Checksum: 0x773B
Length: 28
Network Mask: /24
TOS: 0 Metric: 1
```

```
SW1#show ip ospf database router 10.255.255.8
```

```
OSPF Router with ID (10.255.255.7) (Process ID 100)
```

```
Router Link States (Area 0)
```

```
Adv Router is not-reachable
LS age: 132
Options: (No TOS-capability, DC)
LS Type: Router Links
Link State ID: 10.255.255.8
Advertising Router: 10.255.255.8
LS Seq Number: 80000006
Checksum: 0x5EE9
Length: 96
Area Border Router
Number of Links: 6
<output omitted>
```

Once the Virtual-Link is configured, it should appear as an adjacency in the `show ip ospf neighbor` output.

SW1#show ip ospf neighbor

Neighbor ID	Pri	State	Dead Time	Address	Interface
10.255.255.8	0	FULL/ -	-	10.100.108.8	OSPF_VL1
10.255.255.1	0	FULL/ -	00:00:36	10.100.17.1	FastEthernet0/1
10.255.255.9	0	FULL/ -	00:00:39	10.100.79.9	Port-channel13
10.255.255.10	0	FULL/ -	00:00:39	10.100.107.10	FastEthernet0/19

SW2#show ip ospf neighbor

Neighbor ID	Pri	State	Dead Time	Address	Interface
10.255.255.7	0	FULL/ -	-	10.100.107.7	OSPF_VL0
10.255.255.4	0	FULL/ -	00:00:33	10.100.48.4	FastEthernet0/4
10.255.255.9	0	FULL/ -	00:00:39	10.100.89.9	FastEthernet0/16
10.255.255.10	0	FULL/ -	00:00:35	10.100.108.10	Port-channel24

For successful Virtual-Links the adjacency state should be FULL.

SW1#show ip ospf virtual-links

```
Virtual Link OSPF_VL1 to router 10.255.255.8 is up
  Run as demand circuit
  DoNotAge LSA allowed.
  Transit area 7810, via interface FastEthernet0/19, Cost of using 2
  Transmit Delay is 1 sec, State POINT_TO_POINT,
  Timer intervals configured, Hello 10, Dead 40, Wait 40, Retransmit 5
  Hello due in 00:00:02
  Adjacency State FULL (Hello suppressed)
  Index 2/2, retransmission queue length 0, number of retransmission
0
  First 0x0(0)/0x0(0) Next 0x0(0)/0x0(0)
  Last retransmission scan length is 0, maximum is 0
  Last retransmission scan time is 0 msec, maximum is 0 msec
SW1#show ip route 10.100.8.0
Routing entry for 10.100.8.0/24
  Known via "ospf 100", distance 110, metric 3, type intra area
  Last update from 10.100.107.10 on FastEthernet0/19, 00:00:24 ago
  Routing Descriptor Blocks:
    * 10.100.107.10, from 10.255.255.8, 00:00:24 ago, via
FastEthernet0/19
      Route metric is 3, traffic share count is 1
```

When the link between SW1 and SW2 is down, traffic is rerouted via the Virtual-Link path.

```
SW1#traceroute 10.100.8.8
```

```
Type escape sequence to abort.  
Tracing the route to 10.100.8.8
```

```
 1 10.100.107.10 8 msec 0 msec 0 msec  
 2 10.100.108.8 9 msec * 0 msec
```

3.6 OSPF Path Selection

```
R2#
interface Serial0/0.204 point-to-point
 ip ospf cost 128
```

```
R5#
interface Serial0/0/0.501 point-to-point
 ip ospf cost 128
```

Note

OSPF cost is calculated as an inverse function of bandwidth. A bandwidth of 1544Kbps results in a cost of 64. By raising the backup link to a cost higher than this value, the lower cost path is preferred.

R2#show ip ospf interface brief

Interface	PID	Area	IP Address/Mask	Cost	State	Nbrs	F/C
Se0/0.204	100	1245	10.0.0.10/29	128	P2MP	1/1	
Se0/0.201	100	1245	10.0.0.2/29	64	P2MP	1/1	
Lo0	100	1245	10.255.255.2/32	1	LOOP	0/0	
Fa0/0.203	100	1245	10.20.3.2/24	1	DR	0/0	
Fa0/0.202	100	1245	10.20.2.2/24	1	DR	0/0	
Fa0/0.201	100	1245	10.20.1.2/24	1	DR	0/0	
Fa0/0.200	100	1245	10.20.0.2/24	1	DR	0/0	

R2#show ip ospf interface Serial0/0.201

```
Serial0/0.201 is up, line protocol is up
 Internet Address 10.0.0.2/29, Area 1245
 Process ID 100, Router ID 10.255.255.2, Network Type
 POINT_TO_MULTIPOINT, Cost: 64
 Transmit Delay is 1 sec, State POINT_TO_MULTIPOINT,
 Timer intervals configured, Hello 200 msec, Dead 1, Wait 1,
 Retransmit 5
 oob-resync timeout 40
 Hello due in 0 msec
 Supports Link-local Signaling (LLS)
 Index 5/5, flood queue length 0
 Next 0x0(0)/0x0(0)
 Last flood scan length is 9, maximum is 32
 Last flood scan time is 0 msec, maximum is 4 msec
 Neighbor Count is 1, Adjacent neighbor count is 1
 Adjacent with neighbor 10.255.255.1
 Suppress hello for 0 neighbor(s)
```

R2#show ip ospf interface Serial0/0.204

```
Serial0/0.204 is up, line protocol is up
  Internet Address 10.0.0.10/29, Area 1245
  Process ID 100, Router ID 10.255.255.2, Network Type
POINT_TO_MULTIPOINT, Cost: 128
  Transmit Delay is 1 sec, State POINT_TO_MULTIPOINT,
  Timer intervals configured, Hello 200 msec, Dead 1, Wait 1,
Retransmit 5
  oob-resync timeout 40
  Hello due in 80 msec
  Supports Link-local Signaling (LLS)
  Index 6/6, flood queue length 0
  Next 0x0(0)/0x0(0)
  Last flood scan length is 1, maximum is 15
  Last flood scan time is 0 msec, maximum is 4 msec
  Neighbor Count is 1, Adjacent neighbor count is 1
    Adjacent with neighbor 10.255.255.4
  Suppress hello for 0 neighbor(s)
```

R2#show ip route ospf

```
10.0.0.0/8 is variably subnetted, 37 subnets, 3 masks
O IA 10.255.255.10/32 [110/67] via 10.0.0.1, 00:07:46, Serial0/0.201
O 10.0.0.11/32 [110/128] via 10.0.0.1, 00:07:46, Serial0/0.201
O IA 10.255.255.8/32 [110/67] via 10.0.0.1, 00:07:46, Serial0/0.201
O IA 10.100.108.0/24 [110/67] via 10.0.0.1, 00:07:46, Serial0/0.201
O IA 10.255.255.9/32 [110/67] via 10.0.0.1, 00:07:46, Serial0/0.201
O 10.0.0.9/32 [110/128] via 10.0.0.9, 00:07:46, Serial0/0.204
O IA 10.100.107.0/24 [110/66] via 10.0.0.1, 00:07:46, Serial0/0.201
O 10.0.0.3/32 [110/128] via 10.0.0.1, 00:07:46, Serial0/0.201
O IA 10.255.255.1/32 [110/65] via 10.0.0.1, 00:07:46, Serial0/0.201
O 10.0.0.1/32 [110/64] via 10.0.0.1, 00:07:46, Serial0/0.201
O IA 10.255.255.7/32 [110/66] via 10.0.0.1, 00:07:46, Serial0/0.201
O IA 10.255.255.4/32 [110/68] via 10.0.0.1, 00:07:46, Serial0/0.201
O 10.255.255.5/32 [110/129] via 10.0.0.1, 00:07:46, Serial0/0.201
O IA 10.100.78.0/24 [110/66] via 10.0.0.1, 00:07:47, Serial0/0.201
O IA 10.100.79.0/24 [110/66] via 10.0.0.1, 00:07:47, Serial0/0.201
O IA 10.100.89.0/24 [110/67] via 10.0.0.1, 00:07:47, Serial0/0.201
O 10.50.0.0/24 [110/129] via 10.0.0.1, 00:07:47, Serial0/0.201
O 10.50.1.0/24 [110/129] via 10.0.0.1, 00:07:47, Serial0/0.201
O 10.50.2.0/24 [110/129] via 10.0.0.1, 00:07:47, Serial0/0.201
O 10.50.3.0/24 [110/129] via 10.0.0.1, 00:07:47, Serial0/0.201
O 10.50.4.0/24 [110/129] via 10.0.0.1, 00:07:47, Serial0/0.201
O 10.50.5.0/24 [110/129] via 10.0.0.1, 00:07:47, Serial0/0.201
O 10.50.6.0/24 [110/129] via 10.0.0.1, 00:07:47, Serial0/0.201
O 10.50.7.0/24 [110/129] via 10.0.0.1, 00:07:47, Serial0/0.201
O IA 10.100.48.0/24 [110/67] via 10.0.0.1, 00:07:47, Serial0/0.201
O IA 10.100.10.0/24 [110/67] via 10.0.0.1, 00:07:47, Serial0/0.201
O IA 10.100.8.0/24 [110/67] via 10.0.0.1, 00:07:47, Serial0/0.201
O IA 10.100.9.0/24 [110/67] via 10.0.0.1, 00:07:47, Serial0/0.201
O IA 10.100.7.0/24 [110/66] via 10.0.0.1, 00:07:48, Serial0/0.201
O IA 10.100.17.0/24 [110/65] via 10.0.0.1, 00:07:48, Serial0/0.201
```

R2 uses R1 as its exit point, while R5 uses R4.

R2#traceroute 10.100.10.10

Type escape sequence to abort.
Tracing the route to 10.100.10.10

```
1 10.0.0.1 28 msec 28 msec 44 msec
2 10.100.17.7 36 msec 28 msec 32 msec
3 10.100.107.10 28 msec * 28 msec
```

R5#traceroute 10.100.10.10

Type escape sequence to abort.
Tracing the route to 10.100.10.10

```
1 10.0.0.9 28 msec 44 msec 32 msec
2 10.100.48.8 32 msec 32 msec 56 msec
3 10.100.108.10 40 msec * 28 msec
```

3.7 OSPF Summarization

```
R1#
router ospf 100
 area 1245 range 10.20.0.0 255.255.252.0

R4#
router ospf 100
 area 1245 range 10.20.0.0 255.255.252.0

R5#
router ospf 100
 no network 0.0.0.0 255.255.255.255 area 1245
 network 10.0.0.3 0.0.0.0 area 1245
 network 10.0.0.11 0.0.0.0 area 1245
 network 10.255.255.5 0.0.0.0 area 1245
 redistribute connected subnets
 summary-address 10.50.0.0 255.255.248.0
```

Note

Inter-area summarization is configured on the ABR(s), while external summarization is configured on the ASBRs. Note per the below output only R5 knows the subnets of the 10.50.x.x network, while all routers in area 1245 know the subnets of the 10.20.x.x network.

```
R1#show ip route | include 10.20.|10.50.
O      10.20.2.0/24 [110/65] via 10.0.0.2, 00:01:17, Serial0/0
O      10.20.3.0/24 [110/65] via 10.0.0.2, 00:01:17, Serial0/0
O      10.20.0.0/24 [110/65] via 10.0.0.2, 00:01:17, Serial0/0
O      10.20.0.0/22 is a summary, 00:01:17, Null0
O      10.20.1.0/24 [110/65] via 10.0.0.2, 00:01:17, Serial0/0
O E2   10.50.0.0/21 [110/20] via 10.0.0.3, 00:01:17, Serial0/0

R2#show ip route | include 10.20.|10.50.
C      10.20.2.0/24 is directly connected, FastEthernet0/0.202
C      10.20.3.0/24 is directly connected, FastEthernet0/0.203
C      10.20.0.0/24 is directly connected, FastEthernet0/0.200
O IA   10.20.0.0/22 [110/196] via 10.0.0.9, 00:01:21, Serial0/0.204
C      10.20.1.0/24 is directly connected, FastEthernet0/0.201
O E2   10.50.0.0/21 [110/20 ] via 10.0.0.1, 00:01:16, Serial0/0.201

R4#show ip route | include 10.20.|10.50.
O      10.20.2.0/24 [110/65] via 10.0.0.10, 00:01:10, Serial0/0/0
O      10.20.3.0/24 [110/65] via 10.0.0.10, 00:01:10, Serial0/0/0
O      10.20.0.0/24 [110/65] via 10.0.0.10, 00:01:10, Serial0/0/0
O      10.20.0.0/22 is a summary, 00:01:10, Null0
O      10.20.1.0/24 [110/65] via 10.0.0.10, 00:01:10, Serial0/0/0
O E2   10.50.0.0/21 [110/20] via 10.0.0.11, 00:01:10, Serial0/0/0
```

R5#show ip route | include 10.20.|10.50.

```
O      10.20.2.0/24 [110/129] via 10.0.0.9, 00:02:07, Serial0/0/0.504
O      10.20.3.0/24 [110/129] via 10.0.0.9, 00:02:07, Serial0/0/0.504
O      10.20.0.0/24 [110/129] via 10.0.0.9, 00:02:07, Serial0/0/0.504
O IA   10.20.0.0/22 [110/132] via 10.0.0.9, 00:01:29, Serial0/0/0.504
O      10.20.1.0/24 [110/129] via 10.0.0.9, 00:02:07, Serial0/0/0.504
C      10.50.0.0/24 is directly connected, FastEthernet0/0.500
O      10.50.0.0/21 is a summary, 00:01:56, Null0
C      10.50.1.0/24 is directly connected, FastEthernet0/0.501
C      10.50.2.0/24 is directly connected, FastEthernet0/0.502
C      10.50.3.0/24 is directly connected, FastEthernet0/0.503
C      10.50.4.0/24 is directly connected, FastEthernet0/0.504
C      10.50.5.0/24 is directly connected, FastEthernet0/0.505
C      10.50.6.0/24 is directly connected, FastEthernet0/0.506
C      10.50.7.0/24 is directly connected, FastEthernet0/0.507
```

SW1#show ip route | include 10.20.|10.50.

```
O IA   10.20.0.0/22 [110/66] via 10.100.17.1, 00:01:18, FastEthernet0/1
O E2   10.50.0.0/21 [110/20] via 10.100.17.1, 00:01:13, FastEthernet0/1
```

SW2#show ip route | include 10.20.|10.50.

```
O IA   10.20.0.0/22 [110/66] via 10.100.48.4, 00:01:22, FastEthernet0/4
O E2   10.50.0.0/21 [110/20] via 10.100.48.4, 00:01:17, FastEthernet0/4
```

3.8 OSPF Stub Areas

```
R1#  
router ospf 100  
  area 1245 nssa no-summary
```

```
R2#  
router ospf 100  
  area 1245 nssa
```

```
R4#  
router ospf 100  
  area 1245 nssa no-summary
```

```
R5#  
router ospf 100  
  area 1245 nssa
```

```
SW1#  
router ospf 100  
  area 789 stub no-summary  
  area 789 default-cost 100
```

```
SW2#  
router ospf 100  
  area 789 stub no-summary  
  area 789 default-cost 200
```

```
SW3#  
router ospf 100  
  area 789 stub
```

 **Note**

Prior to the Not-So-Totally-Stubby configuration devices in area 1245 know intra-area, inter-area, and external routes.

```
R2#show ip route ospf
    10.0.0.0/8 is variably subnetted, 30 subnets, 4 masks
O IA   10.255.255.10/32 [110/67] via 10.0.0.1, 00:15:53, Serial0/0.201
O      10.0.0.11/32 [110/128] via 10.0.0.1, 00:21:54, Serial0/0.201
O IA   10.255.255.8/32 [110/67] via 10.0.0.1, 00:15:44, Serial0/0.201
O IA   10.100.108.0/24 [110/67] via 10.0.0.1, 00:17:02, Serial0/0.201
O IA   10.255.255.9/32 [110/67] via 10.0.0.1, 00:16:17, Serial0/0.201
O      10.0.0.9/32 [110/128] via 10.0.0.9, 00:21:54, Serial0/0.204
O IA   10.100.107.0/24 [110/66] via 10.0.0.1, 00:17:09, Serial0/0.201
O      10.0.0.3/32 [110/128] via 10.0.0.1, 00:21:54, Serial0/0.201
O IA   10.255.255.1/32 [110/65] via 10.0.0.1, 00:15:44, Serial0/0.201
O      10.0.0.1/32 [110/64] via 10.0.0.1, 00:21:54, Serial0/0.201
O IA   10.255.255.7/32 [110/66] via 10.0.0.1, 00:15:44, Serial0/0.201
O IA   10.255.255.4/32 [110/68] via 10.0.0.1, 00:15:44, Serial0/0.201
O      10.255.255.5/32 [110/129] via 10.0.0.1, 00:21:54, Serial0/0.201
O IA   10.100.78.0/24 [110/66] via 10.0.0.1, 00:17:10, Serial0/0.201
O IA   10.100.79.0/24 [110/66] via 10.0.0.1, 00:17:10, Serial0/0.201
O IA   10.100.89.0/24 [110/67] via 10.0.0.1, 00:17:03, Serial0/0.201
O E2   10.50.0.0/21 [110/20] via 10.0.0.1, 00:15:55, Serial0/0.201
O IA   10.100.48.0/24 [110/67] via 10.0.0.1, 00:15:45, Serial0/0.201
O IA   10.100.10.0/24 [110/67] via 10.0.0.1, 00:15:54, Serial0/0.201
O IA   10.100.8.0/24 [110/67] via 10.0.0.1, 00:15:45, Serial0/0.201
O IA   10.100.9.0/24 [110/67] via 10.0.0.1, 00:16:18, Serial0/0.201
O IA   10.100.7.0/24 [110/66] via 10.0.0.1, 00:15:45, Serial0/0.201
O IA   10.100.17.0/24 [110/65] via 10.0.0.1, 00:15:45, Serial0/0.201
```

After the Not-So-Totally-Stubby configuration, devices in area 1245 know intra-area routes, a default route to the ABR(s), and Type-7 NSSA External routes.

```
R2#show ip route ospf
    10.0.0.0/8 is variably subnetted, 13 subnets, 4 masks
O      10.0.0.11/32 [110/128] via 10.0.0.1, 00:00:01, Serial0/0.201
O      10.0.0.9/32 [110/128] via 10.0.0.9, 00:00:01, Serial0/0.204
O      10.0.0.3/32 [110/128] via 10.0.0.1, 00:00:01, Serial0/0.201
O      10.0.0.1/32 [110/64] via 10.0.0.1, 00:00:01, Serial0/0.201
O      10.255.255.5/32 [110/129] via 10.0.0.1, 00:00:01, Serial0/0.201
O N2   10.50.0.0/21 [110/20] via 10.0.0.1, 00:00:01, Serial0/0.201
O*IA 0.0.0.0/0 [110/65] via 10.0.0.1, 00:00:01, Serial0/0.201
```

R2#show ip ospf database

OSPF Router with ID (10.255.255.2) (Process ID 100)

Router Link States (Area 1245)

Link ID	ADV Router	Age	Seq#	Checksum	Link count
10.255.255.1	10.255.255.1	37	0x80000011	0x00A387	3
10.255.255.2	10.255.255.2	43	0x80000015	0x009644	9
10.255.255.4	10.255.255.4	37	0x80000011	0x00C547	3
10.255.255.5	10.255.255.5	37	0x80000016	0x00533A	5

Summary Net Link States (Area 1245)

Link ID	ADV Router	Age	Seq#	Checksum
0.0.0.0	10.255.255.1	55	0x80000001	0x00D852
0.0.0.0	10.255.255.4	52	0x80000001	0x00C661

Type-7 AS External Link States (Area 1245)

Link ID	ADV Router	Age	Seq#	Checksum	Tag
10.50.0.0	10.255.255.5	38	0x80000001	0x008FB3	0

Before the Totally Stubby configuration of area 789, intra-area, inter-area, and external routes are known.

```
SW3#show ip route ospf
 10.0.0.0/8 is variably subnetted, 27 subnets, 4 masks
O IA   10.255.255.10/32 [110/3] via 10.100.89.8, 00:17:22, FastEthernet0/16
        [110/3] via 10.100.79.7, 00:17:22, Port-channel13
O IA   10.0.0.10/32 [110/66] via 10.100.89.8, 00:00:51, FastEthernet0/16
        [110/66] via 10.100.79.7, 00:00:51, Port-channel13
O IA   10.0.0.11/32 [110/66] via 10.100.89.8, 00:00:41, FastEthernet0/16
        [110/66] via 10.100.79.7, 00:00:41, Port-channel13
O IA   10.255.255.8/32 [110/2] via 10.100.89.8, 00:17:36, FastEthernet0/16
O IA   10.100.108.0/24 [110/2] via 10.100.89.8, 00:17:36, FastEthernet0/16
O IA   10.0.0.9/32 [110/2] via 10.100.89.8, 00:17:36, FastEthernet0/16
O IA   10.100.107.0/24 [110/2] via 10.100.79.7, 00:17:36, Port-channel13
O IA   10.255.255.2/32 [110/67] via 10.100.89.8, 00:00:52, FastEthernet0/16
        [110/67] via 10.100.79.7, 00:00:52, Port-channel13
O IA   10.0.0.2/32 [110/66] via 10.100.89.8, 00:00:52, FastEthernet0/16
        [110/66] via 10.100.79.7, 00:00:53, Port-channel13
O IA   10.0.0.3/32 [110/66] via 10.100.89.8, 00:00:43, FastEthernet0/16
        [110/66] via 10.100.79.7, 00:00:43, Port-channel13
O IA   10.255.255.1/32 [110/3] via 10.100.79.7, 00:17:37, Port-channel13
O IA   10.0.0.1/32 [110/2] via 10.100.79.7, 00:17:37, Port-channel13
O IA   10.255.255.7/32 [110/2] via 10.100.79.7, 00:17:37, Port-channel13
O IA   10.255.255.4/32 [110/3] via 10.100.89.8, 00:17:37, FastEthernet0/16
O IA   10.255.255.5/32 [110/67] via 10.100.89.8, 00:00:43, FastEthernet0/16
        [110/67] via 10.100.79.7, 00:00:43, Port-channel13
O IA   10.20.0.0/22 [110/67] via 10.100.89.8, 00:00:53, FastEthernet0/16
        [110/67] via 10.100.79.7, 00:00:53, Port-channel13
O IA   10.100.78.0/24 [110/2] via 10.100.89.8, 00:17:38, FastEthernet0/16
        [110/2] via 10.100.79.7, 00:17:38, Port-channel13
O E2   10.50.0.0/21 [110/20] via 10.100.89.8, 00:00:41, FastEthernet0/16
        [110/20] via 10.100.79.7, 00:00:41, Port-channel13
O IA   10.100.48.0/24 [110/2] via 10.100.89.8, 00:17:38, FastEthernet0/16
O IA   10.100.10.0/24 [110/3] via 10.100.89.8, 00:17:25, FastEthernet0/16
        [110/3] via 10.100.79.7, 00:17:25, Port-channel13
O IA   10.100.8.0/24 [110/2] via 10.100.89.8, 00:17:38, FastEthernet0/16
O IA   10.100.7.0/24 [110/2] via 10.100.79.7, 00:17:38, Port-channel13
O IA   10.100.17.0/24 [110/2] via 10.100.79.7, 00:17:38, Port-channel13
```

After the Totally Stubby configuration the only route left is an inter-area default route to SW1 due to the lower cost.

SW3#show ip route ospf

O*IA 0.0.0.0/0 [110/101] via 10.100.79.7, 00:00:06, Port-channel13

Both default routes via SW1 and SW2 are installed in the database, but only one makes it to the routing table due to the lower cost.

SW3#show ip ospf database

OSPF Router with ID (10.255.255.9) (Process ID 100)

Router Link States (Area 789)

Link ID	ADV Router	Age	Seq#	Checksum	Link count
10.255.255.7	10.255.255.7	15	0x80000009	0x0073F0	2
10.255.255.8	10.255.255.8	10	0x8000000B	0x00C288	2
10.255.255.9	10.255.255.9	12	0x8000000E	0x00AA3A	6

Summary Net Link States (Area 789)

Link ID	ADV Router	Age	Seq#	Checksum
0.0.0.0	10.255.255.7	19	0x80000001	0x000FBA
0.0.0.0	10.255.255.8	15	0x80000001	0x00F46F

4.1 Level-2 IS-IS

Configuration

```
R1#
interface Loopback0
  isis circuit-type level-2-only
!
interface FastEthernet0/0.1
  isis circuit-type level-2-only
!
interface FastEthernet0/0.13
  ip router isis 100
  isis circuit-type level-2-only
!
interface FastEthernet0/0.14
  ip router isis 100
  isis circuit-type level-2-only
!
interface FastEthernet0/0.16
  ip router isis 100
  isis circuit-type level-2-only
!
router isis 100
  net 49.0014.0000.0000.0001.00
  passive-interface FastEthernet0/0.1
  passive-interface Loopback0

R3#
interface FastEthernet0/0.13
  ip router isis 100
  isis circuit-type level-2-only
!
interface FastEthernet0/0.34
  ip router isis 100
  isis circuit-type level-2-only
!
router isis 100
  net 49.0003.0000.0000.0003.00
  is-type level-2
  passive-interface FastEthernet0/0.3
  passive-interface Loopback0
```

```
R4#
interface Loopback0
  isis circuit-type level-2-only
!
interface FastEthernet0/0.4
  isis circuit-type level-2-only
!
interface FastEthernet0/0.14
  ip router isis 100
  isis circuit-type level-2-only
!
interface FastEthernet0/0.34
  ip router isis 100
  isis circuit-type level-2-only
!
interface FastEthernet0/0.46
  ip router isis 100
  isis circuit-type level-2-only
!
router isis 100
  net 49.0014.0000.0000.0004.00
  passive-interface FastEthernet0/0.4
  passive-interface Loopback0
```

```
R6#
interface FastEthernet0/0.16
  ip router isis 100
  isis circuit-type level-2-only
!
interface FastEthernet0/0.46
  ip router isis 100
  isis circuit-type level-2-only
!
router isis 100
  net 49.0006.0000.0000.0006.00
  is-type level-2
  passive-interface FastEthernet0/0.6
  passive-interface Loopback0
```

Verification

R1#show clns is-neighbors

System Id	Interface	State	Type	Priority	Circuit Id	Format
R6	Fa0/0.16	Up	L2	64	R6.02	Phase V
R3	Fa0/0.13	Up	L2	64	R1.02	Phase V
R4	Fa0/0.14	Up	L2	64	R4.01	Phase V

R3#show clns is-neighbors

System Id	Interface	State	Type	Priority	Circuit Id	Format
R4	Fa0/0.34	Up	L2	64	R4.02	Phase V
R1	Fa0/0.13	Up	L2	64	R1.02	Phase V

R4#show clns is-neighbors

System Id	Interface	State	Type	Priority	Circuit Id	Format
R6	Fa0/0.46	Up	L2	64	R6.01	Phase V
R3	Fa0/0.34	Up	L2	64	R4.02	Phase V
R1	Fa0/0.14	Up	L2	64	R4.01	Phase V

R6#show clns is-neighbors

System Id	Interface	State	Type	Priority	Circuit Id	Format
R1	Fa0/0.16	Up	L2	64	R6.02	Phase V
R4	Fa0/0.46	Up	L2	64	R6.01	Phase V

R1#show isis database

```
IS-IS Level-1 Link State Database:
LSPID          LSP Seq Num  LSP Checksum  LSP Holdtime  ATT/P/OL
R1.00-00       * 0x00000009  0x1F5B        496            1/0/0
IS-IS Level-2 Link State Database:
LSPID          LSP Seq Num  LSP Checksum  LSP Holdtime  ATT/P/OL
R1.00-00       * 0x0000000C  0xA34A        496            0/0/0
R1.02-00       * 0x00000001  0x33A5        428            0/0/0
R3.00-00       0x00000008  0xF0A7        485            0/0/0
R4.00-00       0x00000009  0xB4F7        502            0/0/0
R4.01-00       0x00000001  0x1ABB        407            0/0/0
R4.02-00       0x00000002  0x438E        1194           0/0/0
R6.00-00       0x00000007  0x333F        474            0/0/0
R6.01-00       0x00000001  0x715D        442            0/0/0
R6.02-00       0x00000002  0x1DB2        1160           0/0/0
```

R3#show isis database

```
IS-IS Level-2 Link State Database:
LSPID          LSP Seq Num  LSP Checksum  LSP Holdtime  ATT/P/OL
R1.00-00       0x00000010  0x9B4E        1162           0/0/0
R1.02-00       0x00000003  0x2FA7        1151           0/0/0
R3.00-00       * 0x0000000C  0xE8AB        1158           0/0/0
R4.00-00       0x0000000E  0xA AFC        1162           0/0/0
R4.01-00       0x00000002  0x18BC        1056           0/0/0
R4.02-00       0x00000003  0x418F        1152           0/0/0
R6.00-00       0x0000000B  0x2B43        1165           0/0/0
R6.01-00       0x00000002  0x6F5E        1160           0/0/0
R6.02-00       0x00000003  0x1BB3        1161           0/0/0
```

R4#show isis database

```
IS-IS Level-1 Link State Database:
LSPID          LSP Seq Num  LSP Checksum  LSP Holdtime  ATT/P/OL
R4.00-00       * 0x00000007  0x4726        1157          1/0/0
IS-IS Level-2 Link State Database:
LSPID          LSP Seq Num  LSP Checksum  LSP Holdtime  ATT/P/OL
R1.00-00       0x00000010  0x9B4E        1159          0/0/0
R1.02-00       0x00000003  0x2FA7        1149          0/0/0
R3.00-00       0x0000000C  0xE8AB        1153          0/0/0
R4.00-00       * 0x0000000E  0xAAFC        1161          0/0/0
R4.01-00       * 0x00000002  0x18BC        1055          0/0/0
R4.02-00       * 0x00000003  0x418F        1151          0/0/0
R6.00-00       0x0000000B  0x2B43        1164          0/0/0
R6.01-00       0x00000002  0x6F5E        1159          0/0/0
R6.02-00       0x00000003  0x1BB3        1159          0/0/0
```

R6#show isis database

```
IS-IS Level-2 Link State Database:
LSPID          LSP Seq Num  LSP Checksum  LSP Holdtime  ATT/P/OL
R1.00-00       0x00000010  0x9B4E        1155          0/0/0
R1.02-00       0x00000003  0x2FA7        1146          0/0/0
R3.00-00       0x0000000C  0xE8AB        1149          0/0/0
R4.00-00       0x0000000E  0xAAFC        1155          0/0/0
R4.01-00       0x00000002  0x18BC        1049          0/0/0
R4.02-00       0x00000003  0x418F        1145          0/0/0
R6.00-00       * 0x0000000B  0x2B43        1162          0/0/0
R6.01-00       * 0x00000002  0x6F5E        1157          0/0/0
R6.02-00       * 0x00000003  0x1BB3        1157          0/0/0
```

R1#show ip route isis

```
10.0.0.0/8 is variably subnetted, 15 subnets, 3 masks
i L2 10.255.255.3/32 [115/10] via 10.100.13.3, FastEthernet0/0.13
i L2 10.255.255.6/32 [115/10] via 10.100.16.6, FastEthernet0/0.16
i L2 10.255.255.4/32 [115/10] via 10.100.14.4, FastEthernet0/0.14
i L2 10.100.46.0/24 [115/20] via 10.100.16.6, FastEthernet0/0.16
    [115/20] via 10.100.14.4, FastEthernet0/0.14
i L2 10.100.34.0/24 [115/20] via 10.100.14.4, FastEthernet0/0.14
    [115/20] via 10.100.13.3, FastEthernet0/0.13
i L2 10.100.6.0/24 [115/10] via 10.100.16.6, FastEthernet0/0.16
i L2 10.100.4.0/24 [115/10] via 10.100.14.4, FastEthernet0/0.14
i L2 10.100.3.0/24 [115/10] via 10.100.13.3, FastEthernet0/0.13
```

R3#show ip route isis

```
10.0.0.0/8 is variably subnetted, 13 subnets, 2 masks
i L2 10.255.255.1/32 [115/10] via 10.100.13.1, FastEthernet0/0.13
i L2 10.255.255.6/32 [115/20] via 10.100.34.4, FastEthernet0/0.34
    [115/20] via 10.100.13.1, FastEthernet0/0.13
i L2 10.255.255.4/32 [115/10] via 10.100.34.4, FastEthernet0/0.34
i L2 10.100.46.0/24 [115/20] via 10.100.34.4, FastEthernet0/0.34
i L2 10.100.14.0/24 [115/20] via 10.100.34.4, FastEthernet0/0.34
    [115/20] via 10.100.13.1, FastEthernet0/0.13
i L2 10.100.6.0/24 [115/20] via 10.100.34.4, FastEthernet0/0.34
    [115/20] via 10.100.13.1, FastEthernet0/0.13
i L2 10.100.4.0/24 [115/10] via 10.100.34.4, FastEthernet0/0.34
i L2 10.100.1.0/24 [115/10] via 10.100.13.1, FastEthernet0/0.13
i L2 10.100.16.0/24 [115/20] via 10.100.13.1, FastEthernet0/0.13
```

R4#show ip route isis

```
10.0.0.0/8 is variably subnetted, 15 subnets, 3 masks
i L2    10.255.255.3/32 [115/10] via 10.100.34.3, FastEthernet0/0.34
i L2    10.255.255.1/32 [115/10] via 10.100.14.1, FastEthernet0/0.14
i L2    10.255.255.6/32 [115/10] via 10.100.46.6, FastEthernet0/0.46
i L2    10.100.13.0/24 [115/20] via 10.100.34.3, FastEthernet0/0.34
        [115/20] via 10.100.14.1, FastEthernet0/0.14
i L2    10.100.6.0/24 [115/10] via 10.100.46.6, FastEthernet0/0.46
i L2    10.100.3.0/24 [115/10] via 10.100.34.3, FastEthernet0/0.34
i L2    10.100.1.0/24 [115/10] via 10.100.14.1, FastEthernet0/0.14
i L2    10.100.16.0/24 [115/20] via 10.100.46.6, FastEthernet0/0.46
        [115/20] via 10.100.14.1, FastEthernet0/0.14
```

R6#show ip route isis

```
10.0.0.0/8 is variably subnetted, 13 subnets, 2 masks
i L2    10.255.255.3/32 [115/20] via 10.100.46.4, FastEthernet0/0.46
        [115/20] via 10.100.16.1, FastEthernet0/0.16
i L2    10.255.255.1/32 [115/10] via 10.100.16.1, FastEthernet0/0.16
i L2    10.255.255.4/32 [115/10] via 10.100.46.4, FastEthernet0/0.46
i L2    10.100.34.0/24 [115/20] via 10.100.46.4, FastEthernet0/0.46
i L2    10.100.14.0/24 [115/20] via 10.100.46.4, FastEthernet0/0.46
        [115/20] via 10.100.16.1, FastEthernet0/0.16
i L2    10.100.13.0/24 [115/20] via 10.100.16.1, FastEthernet0/0.16
i L2    10.100.4.0/24 [115/10] via 10.100.46.4, FastEthernet0/0.46
i L2    10.100.3.0/24 [115/20] via 10.100.46.4, FastEthernet0/0.46
        [115/20] via 10.100.16.1, FastEthernet0/0.16
i L2    10.100.1.0/24 [115/10] via 10.100.16.1, FastEthernet0/0.16
```

4.2 Level-1 IS-IS

Configuration

```
R1#
interface Serial0/0.102 point-to-point
 ip router isis 100
 isis circuit-type level-1
!
interface Serial0/0.105 point-to-point
 ip router isis 100
 isis circuit-type level-1

R2#
interface Serial0/0.201 point-to-point
 ip router isis 100
!
interface Serial0/0.204 point-to-point
 ip router isis 100
!
router isis 100
 net 49.0014.0000.0000.0002.00
 is-type level-1
 passive-interface default
 no passive-interface Serial0/0.201
 no passive-interface Serial0/0.204

R4#
interface Serial0/0/0.402 point-to-point
 ip router isis 100
 isis circuit-type level-1
!
interface Serial0/0/0.405 point-to-point
 ip router isis 100
 isis circuit-type level-1

R5#
interface Serial0/0/0.501 point-to-point
 ip router isis 100
!
interface Serial0/0/0.504 point-to-point
 ip router isis 100
!
router isis 100
 net 49.0014.0000.0000.0005.00
 is-type level-1
 passive-interface Loopback0
```

Verification**R1#show clns is-neighbors**

System Id	Interface	State	Type	Priority	Circuit Id	Format
R5	Se0/0.105	Up	L1	0	00	Phase V
R2	Se0/0.102	Up	L1	0	00	Phase V
R3	Fa0/0.13	Up	L2	64	R1.02	Phase V
R6	Fa0/0.16	Up	L2	64	R6.02	Phase V
R4	Fa0/0.14	Up	L2	64	R4.01	Phase V

R2#show clns is-neighbors

System Id	Interface	State	Type	Priority	Circuit Id	Format
R1	Se0/0.201	Up	L1	0	00	Phase V
R4	Se0/0.204	Up	L1	0	00	Phase V

R4#show clns is-neighbors

System Id	Interface	State	Type	Priority	Circuit Id	Format
R2	Se0/0/0.402	Up	L1	0	01	Phase V
R5	Se0/0/0.405	Up	L1	0	01	Phase V
R6	Fa0/0.46	Up	L2	64	R6.01	Phase V
R3	Fa0/0.34	Up	L2	64	R4.02	Phase V
R1	Fa0/0.14	Up	L2	64	R4.01	Phase V

R5#show clns is-neighbors

System Id	Interface	State	Type	Priority	Circuit Id	Format
R1	Se0/0/0.501	Up	L1	0	01	Phase V
R4	Se0/0/0.504	Up	L1	0	01	Phase V
R5#						

**Note**

R1 has both the Level-1 and Level-2 databases since it is an L1/L2 router.

R1#show isis database**IS-IS Level-1 Link State Database:**

LSPID	LSP Seq Num	LSP Checksum	LSP Holdtime	ATT/P/OL
R1.00-00	* 0x00000016	0x8109	1074	1/0/0
R2.00-00	0x0000000B	0x3E11	1070	0/0/0
R4.00-00	0x0000000D	0x3849	941	1/0/0
R5.00-00	0x0000000B	0xC62D	1072	0/0/0

IS-IS Level-2 Link State Database:

LSPID	LSP Seq Num	LSP Checksum	LSP Holdtime	ATT/P/OL
R1.00-00	* 0x00000024	0x46C5	1079	0/0/0
R1.02-00	* 0x00000005	0x2BA9	1044	0/0/0
R3.00-00	0x0000000F	0xE2AE	1045	0/0/0
R4.00-00	0x00000016	0xD005	945	0/0/0
R4.01-00	0x00000003	0x16BD	510	0/0/0
R4.02-00	0x00000004	0x3F90	571	0/0/0
R6.00-00	0x0000000C	0x2944	569	0/0/0
R6.01-00	0x00000003	0x6D5F	685	0/0/0
R6.02-00	0x00000004	0x19B4	510	0/0/0

R2 only has the Level-1 database since it is an L1 only router. Also note that both R1 and R4 are setting the Attached (ATT) bit in the database, which allows the Level-1 routers to use them as a default exit point to reach the Level-2 domain.

R2#show isis database

```
IS-IS Level-1 Link State Database:
LSPID          LSP Seq Num  LSP Checksum  LSP Holdtime  ATT/P/OL
R1.00-00       0x00000016   0x8109        1067           1/0/0
R2.00-00       * 0x0000000B  0x3E11        1066           0/0/0
R4.00-00       0x0000000D   0x3849        938            1/0/0
R5.00-00       0x0000000B   0xC62D        1064           0/0/0
```

R1#show ip route isis

```
10.0.0.0/8 is variably subnetted, 23 subnets, 3 masks
i L1 10.255.255.2/32 [115/10] via 10.0.0.1, Serial0/0.102
i L2 10.255.255.3/32 [115/10] via 10.100.13.3, FastEthernet0/0.13
i L2 10.255.255.6/32 [115/10] via 10.100.16.6, FastEthernet0/0.16
i L1 10.0.0.6/31 [115/20] via 10.0.0.3, Serial0/0.105
i L2 10.255.255.4/32 [115/10] via 10.100.14.4, FastEthernet0/0.14
i L1 10.0.0.4/31 [115/20] via 10.0.0.1, Serial0/0.102
i L1 10.255.255.5/32 [115/10] via 10.0.0.3, Serial0/0.105
i L1 10.20.2.0/24 [115/10] via 10.0.0.1, Serial0/0.102
i L1 10.20.3.0/24 [115/10] via 10.0.0.1, Serial0/0.102
i L1 10.20.0.0/24 [115/10] via 10.0.0.1, Serial0/0.102
i L1 10.20.1.0/24 [115/10] via 10.0.0.1, Serial0/0.102
i L2 10.100.46.0/24 [115/20] via 10.100.16.6, FastEthernet0/0.16
      [115/20] via 10.100.14.4, FastEthernet0/0.14
i L2 10.100.34.0/24 [115/20] via 10.100.14.4, FastEthernet0/0.14
      [115/20] via 10.100.13.3, FastEthernet0/0.13
i L2 10.100.6.0/24 [115/10] via 10.100.16.6, FastEthernet0/0.16
i L2 10.100.4.0/24 [115/10] via 10.100.14.4, FastEthernet0/0.14
i L2 10.100.3.0/24 [115/10] via 10.100.13.3, FastEthernet0/0.13
```

Level-1 only routers only know about the routes within Level-1, and the default routes out to the L1/L2 routers.

R2#show ip route isis

```
10.0.0.0/8 is variably subnetted, 10 subnets, 3 masks
i L1 10.0.0.2/31 [115/20] via 10.0.0.0, Serial0/0.201
i L1 10.0.0.6/31 [115/20] via 10.0.0.4, Serial0/0.204
i L1 10.255.255.5/32 [115/20] via 10.0.0.4, Serial0/0.204
      [115/20] via 10.0.0.0, Serial0/0.201
i*L1 0.0.0.0/0 [115/10] via 10.0.0.4, Serial0/0.204
      [115/10] via 10.0.0.0, Serial0/0.201
```

R4#show ip route isis

```
10.0.0.0/8 is variably subnetted, 23 subnets, 3 masks
i L1 10.255.255.2/32 [115/10] via 10.0.0.5, Serial0/0/0.402
i L1 10.0.0.2/31 [115/20] via 10.0.0.7, Serial0/0/0.405
i L2 10.255.255.3/32 [115/10] via 10.100.34.3, FastEthernet0/0.34
i L1 10.0.0.0/31 [115/20] via 10.0.0.5, Serial0/0/0.402
i L2 10.255.255.1/32 [115/10] via 10.100.14.1, FastEthernet0/0.14
i L2 10.255.255.6/32 [115/10] via 10.100.46.6, FastEthernet0/0.46
i L1 10.255.255.5/32 [115/10] via 10.0.0.7, Serial0/0/0.405
i L1 10.20.2.0/24 [115/10] via 10.0.0.5, Serial0/0/0.402
i L1 10.20.3.0/24 [115/10] via 10.0.0.5, Serial0/0/0.402
i L1 10.20.0.0/24 [115/10] via 10.0.0.5, Serial0/0/0.402
i L1 10.20.1.0/24 [115/10] via 10.0.0.5, Serial0/0/0.402
i L2 10.100.13.0/24 [115/20] via 10.100.34.3, FastEthernet0/0.34
      [115/20] via 10.100.14.1, FastEthernet0/0.14
i L2 10.100.6.0/24 [115/10] via 10.100.46.6, FastEthernet0/0.46
i L2 10.100.3.0/24 [115/10] via 10.100.34.3, FastEthernet0/0.34
i L2 10.100.1.0/24 [115/10] via 10.100.14.1, FastEthernet0/0.14
i L2 10.100.16.0/24 [115/20] via 10.100.46.6, FastEthernet0/0.46
      [115/20] via 10.100.14.1, FastEthernet0/0.14
```

R5#show ip route isis

```
10.0.0.0/8 is variably subnetted, 18 subnets, 3 masks
i L1 10.255.255.2/32 [115/20] via 10.0.0.6, Serial0/0/0.504
      [115/20] via 10.0.0.2, Serial0/0/0.501
i L1 10.0.0.0/31 [115/20] via 10.0.0.2, Serial0/0/0.501
i L1 10.0.0.4/31 [115/20] via 10.0.0.6, Serial0/0/0.504
i L1 10.20.2.0/24 [115/20] via 10.0.0.6, Serial0/0/0.504
      [115/20] via 10.0.0.2, Serial0/0/0.501
i L1 10.20.3.0/24 [115/20] via 10.0.0.6, Serial0/0/0.504
      [115/20] via 10.0.0.2, Serial0/0/0.501
i L1 10.20.0.0/24 [115/20] via 10.0.0.6, Serial0/0/0.504
      [115/20] via 10.0.0.2, Serial0/0/0.501
i L1 10.20.1.0/24 [115/20] via 10.0.0.6, Serial0/0/0.504
      [115/20] via 10.0.0.2, Serial0/0/0.501
i*L1 0.0.0.0/0 [115/10] via 10.0.0.6, Serial0/0/0.504
      [115/10] via 10.0.0.2, Serial0/0/0.501
```

4.3 IS-IS Optimization

Configuration

```
R1#
interface Serial0/0.102 point-to-point
  isis hello-interval 1
!
interface Serial0/0.105 point-to-point
  isis hello-interval 1
!
interface FastEthernet0/0.13
  isis network point-to-point
!
interface FastEthernet0/0.14
  isis network point-to-point
!
interface FastEthernet0/0.16
  isis network point-to-point

R2#
interface Serial0/0.201 point-to-point
  isis hello-interval 1
!
interface Serial0/0.204 point-to-point
  isis hello-interval 1

R3#
interface FastEthernet0/0.13
  isis network point-to-point
!
interface FastEthernet0/0.34
  isis network point-to-point

R4#
interface Serial0/0/0.401 point-to-point
  isis hello-interval 1
!
interface Serial0/0/0.402 point-to-point
  isis hello-interval 1
!
interface FastEthernet0/0.14
  isis network point-to-point
!
interface FastEthernet0/0.34
  isis network point-to-point
!
interface FastEthernet0/0.46
  isis network point-to-point
```

```
R5#  
interface Serial0/0/0.501 point-to-point  
  isis hello-interval 1  
!  
interface Serial0/0/0.504 point-to-point  
  isis hello-interval 1
```

```
R6#  
interface FastEthernet0/0.16  
  isis network point-to-point  
!  
interface FastEthernet0/0.46  
  isis network point-to-point
```

Verification

```
R1#show clns interface Serial0/0.102
Serial0/0.102 is up, line protocol is up
  Checksums enabled, MTU 1500, Encapsulation FRAME-RELAY
  ERPDUs enabled, min. interval 10 msec.
  CLNS fast switching enabled
  CLNS SSE switching disabled
  DEC compatibility mode OFF for this interface
  Next ESH/ISH in 38 seconds
  Routing Protocol: IS-IS
    Circuit Type: level-1
    Interface number 0x5, local circuit ID 0x100
    Neighbor System-ID: R2
    Level-1 Metric: 10, Priority: 64, Circuit ID: R2.00
    Level-1 IPv6 Metric: 10
    Number of active level-1 adjacencies: 1
    Next IS-IS Hello in 120 milliseconds
  if state UP
```

 **Note**

Adjacencies with a Circuit Id of 00 indicates network type point-to-point, which does not require a DIS election.

R1#show clns is-neighbors

System Id	Interface	State	Type	Priority	Circuit Id	Format
R4	Fa0/0.14	Up	L2	0	00	Phase V
R6	Fa0/0.16	Up	L2	0	00	Phase V
R3	Fa0/0.13	Up	L2	0	00	Phase V
R5	Se0/0.105	Up	L1	0	00	Phase V
R2	Se0/0.102	Up	L1	0	00	Phase V

Previously the database had an entry for each router in the Level-2 domain, and an entry for the DIS of each broadcast link in the Level-2 domain.

R1#show isis database

```
IS-IS Level-1 Link State Database:
LSPID          LSP Seq Num  LSP Checksum  LSP Holdtime  ATT/P/OL
R1.00-00      * 0x00000004  0x1226        1199          1/0/0
R2.00-00      0x00000003  0x4E09        1185          0/0/0
R4.00-00      0x00000003  0x2B60        1190          1/0/0
R5.00-00      0x00000003  0xD625        1182          0/0/0
IS-IS Level-2 Link State Database:
LSPID          LSP Seq Num  LSP Checksum  LSP Holdtime  ATT/P/OL
R1.00-00      * 0x00000003  0x230D        1198          0/0/0
R3.00-00      0x00000002  0x178B        1129          0/0/0
R4.00-00      0x00000005  0xA648        1184          0/0/0
R6.00-00      0x00000003  0xC6B9        1134          0/0/0
```

4.4 IS-IS Security

Configuration

```
R1#
key chain ISIS
  key 1
    key-string DBMIMD5
!
interface Serial0/0.102 point-to-point
  isis authentication mode md5
  isis authentication key-chain ISIS
!
interface Serial0/0.105 point-to-point
  isis authentication mode md5
  isis authentication key-chain ISIS
!
interface FastEthernet0/0.13
  isis authentication mode md5
  isis authentication key-chain ISIS
!
interface FastEthernet0/0.14
  isis authentication mode md5
  isis authentication key-chain ISIS
!
interface FastEthernet0/0.16
  isis authentication mode md5
  isis authentication key-chain ISIS

R2#
key chain ISIS
  key 1
    key-string DBMIMD5
!
interface Serial0/0.201 point-to-point
  isis authentication mode md5
  isis authentication key-chain ISIS
!
interface Serial0/0.204 point-to-point
  isis authentication mode md5
  isis authentication key-chain ISIS

R3#
key chain ISIS
  key 1
    key-string DBMIMD5
!
interface FastEthernet0/0.13
  isis authentication mode md5
  isis authentication key-chain ISIS
!
interface FastEthernet0/0.34
  isis authentication mode md5
  isis authentication key-chain ISIS
```

```
R4#
key chain ISIS
  key 1
    key-string DBMIMD5
  !
interface Serial0/0/0.402 point-to-point
  isis authentication mode md5
  isis authentication key-chain ISIS
!
interface Serial0/0/0.405 point-to-point
  isis authentication mode md5
  isis authentication key-chain ISIS
!
interface FastEthernet0/0.14
  isis authentication mode md5
  isis authentication key-chain ISIS
!
interface FastEthernet0/0.34
  isis authentication mode md5
  isis authentication key-chain ISIS
!
interface FastEthernet0/0.46
  isis authentication mode md5
  isis authentication key-chain ISIS
```

```
R5#
key chain ISIS
  key 1
    key-string DBMIMD5
  !
interface Serial0/0/0.501 point-to-point
  isis authentication mode md5
  isis authentication key-chain ISIS
!
interface Serial0/0/0.504 point-to-point
  isis authentication mode md5
  isis authentication key-chain ISIS
```

```
R6#
key chain ISIS
  key 1
    key-string DBMIMD5
  !
interface FastEthernet0/0.16
  isis authentication mode md5
  isis authentication key-chain ISIS
!
interface FastEthernet0/0.46
  isis authentication mode md5
  isis authentication key-chain ISIS
```

4.5 IS-IS Path Selection

Configuration

```
R1#
ip prefix-list VLAN3 seq 5 permit 10.100.3.0/24
!
route-map ROUTE_LEAKING permit 10
  match ip address prefix-list VLAN3
!
router isis 100
  redistribute isis ip level-2 into level-1 route-map ROUTE_LEAKING

R2#
interface Serial0/0.204 point-to-point
  isis metric 20

R4#
ip prefix-list VLAN6 seq 5 permit 10.100.6.0/24
!
route-map ROUTE_LEAKING permit 10
  match ip address prefix-list VLAN6
!
router isis 100
  redistribute isis ip level-2 into level-1 route-map ROUTE_LEAKING

R5#
interface Serial0/0/0.501 point-to-point
  isis metric 20
```

Verification

 **Note**

R2 and R5, the Level-1 routers, know only install one default route in their routing tables due to the metric modification. Additionally an IS-IS intra-area route is installed for the VLAN3 and VLAN6 subnets that were leaked from Level-2 into Level-1. Since the longest match routing principle forces these routers to choose the /24 routes over the /0 default route, traffic for VLAN3 always transits R1, while traffic for VLAN6 always transits R4. Since the default routes still exist, this traffic can be rerouted if either R1 or R4 goes down.

R2#show ip route isis

```
10.0.0.0/8 is variably subnetted, 12 subnets, 3 masks
i L1 10.0.0.2/31 [115/20] via 10.0.0.0, Serial0/0.201
i L1 10.0.0.6/31 [115/30] via 10.0.0.4, Serial0/0.204
      [115/30] via 10.0.0.0, Serial0/0.201
i L1 10.255.255.5/32 [115/20] via 10.0.0.0, Serial0/0.201
i ia 10.100.6.0/24 [115/158] via 10.0.0.4, Serial0/0.204
i ia 10.100.3.0/24 [115/148] via 10.0.0.0, Serial0/0.201
i*L1 0.0.0.0/0 [115/10] via 10.0.0.0, Serial0/0.201
```

R5#show ip route isis

```
10.0.0.0/8 is variably subnetted, 20 subnets, 3 masks
i L1 10.255.255.2/32 [115/20] via 10.0.0.6, Serial0/0/0.504
i L1 10.0.0.0/31 [115/30] via 10.0.0.6, Serial0/0/0.504
      [115/30] via 10.0.0.2, Serial0/0/0.501
i L1 10.0.0.4/31 [115/20] via 10.0.0.6, Serial0/0/0.504
i L1 10.20.2.0/24 [115/20] via 10.0.0.6, Serial0/0/0.504
i L1 10.20.3.0/24 [115/20] via 10.0.0.6, Serial0/0/0.504
i L1 10.20.0.0/24 [115/20] via 10.0.0.6, Serial0/0/0.504
i L1 10.20.1.0/24 [115/20] via 10.0.0.6, Serial0/0/0.504
i ia 10.100.6.0/24 [115/148] via 10.0.0.6, Serial0/0/0.504
i ia 10.100.3.0/24 [115/158] via 10.0.0.2, Serial0/0/0.501
i*L1 0.0.0.0/0 [115/10] via 10.0.0.6, Serial0/0/0.504
```

R2#traceroute 10.100.3.3

Type escape sequence to abort.
Tracing the route to 10.100.3.3

```
1 10.0.0.0 28 msec 28 msec 765 msec
2 10.100.13.3 797 msec * 289 msec
```

R2#traceroute 10.100.6.6

Type escape sequence to abort.
Tracing the route to 10.100.6.6

```
1 10.0.0.4 188 msec 405 msec 56 msec
2 10.100.46.6 28 msec * 517 msec
```

R2 uses the default route towards R1 for any unmatched routes.

R2#traceroute 10.100.46.6

Type escape sequence to abort.
Tracing the route to 10.100.46.6

```
1 10.0.0.0 333 msec 28 msec 28 msec
2 10.100.16.6 377 msec 380 msec *
```

4.6 IS-IS Summarization

Configuration

```
R1#
router isis 100
  summary-address 10.20.0.0 255.255.252.0

R4#
router isis 100
  summary-address 10.20.0.0 255.255.252.0

R5#
router isis 100
  redistribute connected metric 10 level-1
  summary-address 10.50.0.0 255.255.248.0 level-1
```

Verification

Note

Devices in the Level-1 domain still receive R2's subnets, but R5's external subnets are already summarized.

```
R1#show ip route isis
 10.0.0.0/8 is variably subnetted, 25 subnets, 5 masks
i L1  10.255.255.2/32 [115/10] via 10.0.0.1, Serial0/0.102
i L2  10.255.255.3/32 [115/10] via 10.100.13.3, FastEthernet0/0.13
i L2  10.255.255.6/32 [115/10] via 10.100.16.6, FastEthernet0/0.16
i L1  10.0.0.6/31 [115/20] via 10.0.0.3, Serial0/0.105
i L2  10.255.255.4/32 [115/10] via 10.100.14.4, FastEthernet0/0.14
i L1  10.0.0.4/31 [115/30] via 10.0.0.3, Serial0/0.105
      [115/30] via 10.0.0.1, Serial0/0.102
i L1  10.255.255.5/32 [115/10] via 10.0.0.3, Serial0/0.105
i L1  10.20.2.0/24 [115/10] via 10.0.0.1, Serial0/0.102
i L1  10.20.3.0/24 [115/10] via 10.0.0.1, Serial0/0.102
i L1  10.20.0.0/24 [115/10] via 10.0.0.1, Serial0/0.102
i su  10.20.0.0/22 [115/10] via 0.0.0.0, Null0
i L1  10.20.1.0/24 [115/10] via 10.0.0.1, Serial0/0.102
i L1  10.50.0.0/21 [115/20] via 10.0.0.3, Serial0/0.105
i L2  10.100.46.0/24 [115/20] via 10.100.16.6, FastEthernet0/0.16
      [115/20] via 10.100.14.4, FastEthernet0/0.14
i L2  10.100.34.0/24 [115/20] via 10.100.14.4, FastEthernet0/0.14
      [115/20] via 10.100.13.3, FastEthernet0/0.13
i L2  10.100.6.0/24 [115/10] via 10.100.16.6, FastEthernet0/0.16
i L2  10.100.4.0/24 [115/10] via 10.100.14.4, FastEthernet0/0.14
i L2  10.100.3.0/24 [115/10] via 10.100.13.3, FastEthernet0/0.13
```

Outside Level-1, such as on R3, the subnets for R2 are seen as the single summary that the L1/L2 routers are generating.

```
R3#show ip route isis
      10.0.0.0/8 is variably subnetted, 21 subnets, 5 masks
i L2   10.255.255.2/32 [115/20] via 10.100.34.4, FastEthernet0/0.34
      [115/20] via 10.100.13.1, FastEthernet0/0.13
i L2   10.0.0.2/31 [115/20] via 10.100.13.1, FastEthernet0/0.13
i L2   10.0.0.0/31 [115/20] via 10.100.13.1, FastEthernet0/0.13
i L2   10.255.255.1/32 [115/10] via 10.100.13.1, FastEthernet0/0.13
i L2   10.255.255.6/32 [115/20] via 10.100.34.4, FastEthernet0/0.34
      [115/20] via 10.100.13.1, FastEthernet0/0.13
i L2   10.0.0.6/31 [115/20] via 10.100.34.4, FastEthernet0/0.34
i L2   10.255.255.4/32 [115/10] via 10.100.34.4, FastEthernet0/0.34
i L2   10.0.0.4/31 [115/20] via 10.100.34.4, FastEthernet0/0.34
i L2   10.255.255.5/32 [115/20] via 10.100.34.4, FastEthernet0/0.34
      [115/20] via 10.100.13.1, FastEthernet0/0.13
i L2   10.20.0.0/22 [115/20] via 10.100.34.4, FastEthernet0/0.34
      [115/20] via 10.100.13.1, FastEthernet0/0.13
i L2   10.50.0.0/21 [115/30] via 10.100.34.4, FastEthernet0/0.34
      [115/30] via 10.100.13.1, FastEthernet0/0.13
i L2   10.100.46.0/24 [115/20] via 10.100.34.4, FastEthernet0/0.34
i L2   10.100.14.0/24 [115/20] via 10.100.34.4, FastEthernet0/0.34
      [115/20] via 10.100.13.1, FastEthernet0/0.13
i L2   10.100.6.0/24 [115/20] via 10.100.34.4, FastEthernet0/0.34
      [115/20] via 10.100.13.1, FastEthernet0/0.13
i L2   10.100.4.0/24 [115/10] via 10.100.34.4, FastEthernet0/0.34
i L2   10.100.1.0/24 [115/10] via 10.100.13.1, FastEthernet0/0.13
i L2   10.100.16.0/24 [115/20] via 10.100.13.1, FastEthernet0/0.13
```

5.1 iBGP Peerings

Configuration

R1#

```
router bgp 100
 neighbor 10.255.255.4 remote-as 100
 neighbor 10.255.255.4 update-source Loopback0
 neighbor 10.255.255.4 password DBMIBGP
 neighbor 10.255.255.7 remote-as 100
 neighbor 10.255.255.7 update-source Loopback0
 neighbor 10.255.255.7 password DBMIBGP
 neighbor 10.255.255.8 remote-as 100
 neighbor 10.255.255.8 update-source Loopback0
 neighbor 10.255.255.8 password DBMIBGP
```

R4#

```
router bgp 100
 neighbor 10.255.255.1 remote-as 100
 neighbor 10.255.255.1 update-source Loopback0
 neighbor 10.255.255.1 password DBMIBGP
 neighbor 10.255.255.7 remote-as 100
 neighbor 10.255.255.7 update-source Loopback0
 neighbor 10.255.255.7 password DBMIBGP
 neighbor 10.255.255.8 remote-as 100
 neighbor 10.255.255.8 update-source Loopback0
 neighbor 10.255.255.8 password DBMIBGP
```

SW1#

```
router bgp 100
 neighbor 10.255.255.1 remote-as 100
 neighbor 10.255.255.1 update-source Loopback0
 neighbor 10.255.255.1 password DBMIBGP
 neighbor 10.255.255.4 remote-as 100
 neighbor 10.255.255.4 update-source Loopback0
 neighbor 10.255.255.4 password DBMIBGP
 neighbor 10.255.255.8 remote-as 100
 neighbor 10.255.255.8 update-source Loopback0
 neighbor 10.255.255.8 password DBMIBGP
```

SW2#

```
router bgp 100
 neighbor 10.255.255.1 remote-as 100
 neighbor 10.255.255.1 update-source Loopback0
 neighbor 10.255.255.1 password DBMIBGP
 neighbor 10.255.255.4 remote-as 100
 neighbor 10.255.255.4 update-source Loopback0
 neighbor 10.255.255.4 password DBMIBGP
 neighbor 10.255.255.7 remote-as 100
 neighbor 10.255.255.7 update-source Loopback0
 neighbor 10.255.255.7 password DBMIBGP
```

Verification

R1#show ip bgp summary

BGP router identifier 10.255.255.1, local AS number 100
 BGP table version is 1, main routing table version 1

Neighbor State/PfxRcd	V	AS	MsgRcvd	MsgSent	TblVer	InQ	OutQ	Up/Down	
10.255.255.4	4	100	2	2	0	0	0	00:00:27	0
10.255.255.7	4	100	2	2	0	0	0	00:00:18	0
10.255.255.8	4	100	2	2	0	0	0	00:00:03	0

R4#show ip bgp summary

BGP router identifier 10.255.255.4, local AS number 100
 BGP table version is 1, main routing table version 1

Neighbor State/PfxRcd	V	AS	MsgRcvd	MsgSent	TblVer	InQ	OutQ	Up/Down	
10.255.255.1	4	100	3	2	0	0	0	00:00:39	0
10.255.255.7	4	100	2	2	0	0	0	00:00:33	0
10.255.255.8	4	100	2	2	0	0	0	00:00:24	0

SW1#show ip bgp summary

BGP router identifier 10.255.255.7, local AS number 100
 BGP table version is 1, main routing table version 1

Neighbor State/PfxRcd	V	AS	MsgRcvd	MsgSent	TblVer	InQ	OutQ	Up/Down	
10.255.255.1	4	100	3	2	0	0	0	00:00:34	0
10.255.255.4	4	100	2	2	0	0	0	00:00:36	0
10.255.255.8	4	100	2	2	0	0	0	00:00:28	0

SW2#show ip bgp summary

BGP router identifier 10.255.255.8, local AS number 100
 BGP table version is 1, main routing table version 1

Neighbor State/PfxRcd	V	AS	MsgRcvd	MsgSent	TblVer	InQ	OutQ	Up/Down	
10.255.255.1	4	100	2	2	0	0	0	00:00:21	0
10.255.255.4	4	100	2	2	0	0	0	00:00:29	0
10.255.255.7	4	100	2	2	0	0	0	00:00:30	0

5.2 EBGP Peerings

Configuration

```
R1#
router bgp 100
 neighbor 172.16.13.3 remote-as 300
 neighbor 172.16.13.3 password ISP1BGP
 neighbor 10.255.255.4 next-hop-self
 neighbor 10.255.255.7 next-hop-self
 neighbor 10.255.255.8 next-hop-self
```

```
R4#
router bgp 100
 neighbor 172.16.46.6 remote-as 600
 neighbor 172.16.46.6 password ISP2BGP
 neighbor 172.16.46.6 timers 1 3
 neighbor 10.255.255.1 next-hop-self
 neighbor 10.255.255.7 next-hop-self
 neighbor 10.255.255.8 next-hop-self
```

Verification

R1#show ip bgp summary

```
BGP router identifier 10.255.255.1, local AS number 100
BGP table version is 37, main routing table version 37
24 network entries using 2808 bytes of memory
36 path entries using 1872 bytes of memory
13/6 BGP path/bestpath attribute entries using 1612 bytes of memory
12 BGP AS-PATH entries using 336 bytes of memory
0 BGP route-map cache entries using 0 bytes of memory
0 BGP filter-list cache entries using 0 bytes of memory
BGP using 6628 total bytes of memory
BGP activity 24/0 prefixes, 48/12 paths, scan interval 60 secs
```

Neighbor	V	AS	MsgRcvd	MsgSent	TblVer	InQ	OutQ	Up/Down	
State/PfxRcd									
10.255.255.4	4	100	10	8	37	0	0	00:02:24	12
10.255.255.7	4	100	4	8	37	0	0	00:02:15	0
10.255.255.8	4	100	4	7	37	0	0	00:02:00	0
172.16.13.3	4	300	10	11	37	0	0	00:00:02	24

R4#show ip bgp summary

```
BGP router identifier 10.255.255.4, local AS number 100
BGP table version is 37, main routing table version 37
24 network entries using 3168 bytes of memory
36 path entries using 1872 bytes of memory
10/6 BGP path/bestpath attribute entries using 1680 bytes of memory
9 BGP AS-PATH entries using 312 bytes of memory
0 BGP route-map cache entries using 0 bytes of memory
0 BGP filter-list cache entries using 0 bytes of memory
Bitfield cache entries: current 2 (at peak 2) using 64 bytes of memory
BGP using 7096 total bytes of memory
BGP activity 24/0 prefixes, 36/0 paths, scan interval 60 secs
```

Neighbor	V	AS	MsgRcvd	MsgSent	TblVer	InQ	OutQ	Up/Down	State/PfxRcd
10.255.255.1	4	100	8	10	37	0	0	00:02:41	12
10.255.255.7	4	100	4	10	37	0	0	00:02:35	0
10.255.255.8	4	100	4	10	37	0	0	00:02:25	0
172.16.46.6	4	600	52	48	37	0	0	00:00:43	24

 **Note**

Without next-hop modification on R1 and R4, SW1 and SW2 use default routes to reach the next-hop values of the BGP routes. Since they both default to their closest neighbor, either R1 or R4 respectively, traffic could be blackholed, as seen below. This is solved by using the next-hop-self command on R1 and R4 so that SW1 and SW2 choose the correct exit point out of the network.

SW1#show ip route 182.17.0.1

```
Routing entry for 182.17.0.0/16
  Known via "bgp 100", distance 200, metric 0
  Tag 600, type internal
  Last update from 172.16.46.6 00:03:37 ago
  Routing Descriptor Blocks:
  * 172.16.46.6, from 10.255.255.4, 00:03:37 ago
    Route metric is 0, traffic share count is 1
    AS Hops 1
    Route tag 600
```

SW1#show ip route 172.16.46.6

```
% Network not in table
```

SW1#show ip route 0.0.0.0

```
Routing entry for 0.0.0.0/0, supernet
  Known via "eigrp 100", distance 170, metric 284160, candidate default path,
  type external
  Redistributing via eigrp 100
  Last update from 10.100.17.1 on FastEthernet0/1, 00:04:23 ago
  Routing Descriptor Blocks:
  * 10.100.17.1, from 10.100.17.1, 00:04:23 ago, via FastEthernet0/1
    Route metric is 284160, traffic share count is 1
    Total delay is 10100 microseconds, minimum bandwidth is 100000 Kbit
    Reliability 255/255, minimum MTU 1500 bytes
    Loading 1/255, Hops 1
```

```
R1#show ip route 182.17.0.1
Routing entry for 182.17.0.0/16
  Known via "bgp 100", distance 200, metric 0
  Tag 600, type internal
  Last update from 172.16.46.6 00:17:42 ago
  Routing Descriptor Blocks:
  * 172.16.46.6, from 10.255.255.4, 00:17:42 ago
    Route metric is 0, traffic share count is 1
    AS Hops 1
    Route tag 600
```

```
R1#show ip route 172.16.46.6
% Subnet not in table
```

```
R1#show ip route 0.0.0.0
Routing entry for 0.0.0.0/0, supernet
  Known via "static", distance 1, metric 0 (connected), candidate
  default path
  Redistributing via eigrp 100
  Advertised by eigrp 100 metric 100000 1000 255 1 1500
  Routing Descriptor Blocks:
  * directly connected, via Null0
    Route metric is 0, traffic share count is 1
```

```
SW1#traceroute
Protocol [ip]:
Target IP address: 182.17.0.1
Source address: 10.100.7.7
Numeric display [n]:
Timeout in seconds [3]:
Probe count [3]:
Minimum Time to Live [1]:
Maximum Time to Live [30]:
Port Number [33434]:
Loose, Strict, Record, Timestamp, Verbose[none]:
Type escape sequence to abort.
Tracing the route to 182.17.0.1

 1 10.100.17.1 0 msec 8 msec 0 msec
 2 10.100.17.1 !H * !H
```

After next-hop modification

SW1#show ip bgp

BGP table version is 49, local router ID is 10.255.255.7
 Status codes: s suppressed, d damped, h history, * valid, > best, i - internal,
 r RIB-failure, S Stale
 Origin codes: i - IGP, e - EGP, ? - incomplete

Network	Next Hop	Metric	LocPrf	Weight	Path
*>i1.0.0.0/10	10.255.255.1	0	100	0	300 ?
*>i1.64.0.0/10	10.255.255.1	0	100	0	300 ?
*>i1.128.0.0/10	10.255.255.1	0	100	0	300 ?
*>i1.192.0.0/10	10.255.255.1	0	100	0	300 ?
*>i2.0.0.0/24	10.255.255.4	0	100	0	600 600 600 600 8543 i
*>i2.0.18.0/24	10.255.255.4	0	100	0	600 600 600 600 8543 i
*>i2.0.35.0/24	10.255.255.4	0	100	0	600 600 600 600 8543 i
*>i2.0.87.0/24	10.255.255.4	0	100	0	600 600 600 600 8543 i
*>i4.0.0.0/9	10.255.255.4	0	100	0	600 1221 4637 335 ?
*>i4.128.0.0/9	10.255.255.4	0	100	0	600 1221 4637 335 ?
*>i182.12.0.0	10.255.255.4	0	100	0	600 i
*>i182.13.0.0	10.255.255.4	0	100	0	600 i
*>i182.14.0.0	10.255.255.4	0	100	0	600 i
*>i182.15.0.0	10.255.255.4	0	100	0	600 i
*>i182.16.0.0	10.255.255.4	0	100	0	600 i
*>i182.17.0.0	10.255.255.4	0	100	0	600 i
*>i192.10.0.0/20	10.255.255.1	0	100	0	300 18 243 93 813 i
*>i192.10.16.0/20	10.255.255.1	0	100	0	300 18 243 93 813 i
*>i192.10.32.0/20	10.255.255.1	0	100	0	300 18 243 93 813 i
*>i192.10.48.0/20	10.255.255.1	0	100	0	300 18 243 93 813 i
*>i192.168.0.0	10.255.255.1	0	100	0	300 7018 7018 7018 1200 i
*>i192.168.1.0	10.255.255.1	0	100	0	300 7018 7018 7018 1200 i
*>i192.168.2.0	10.255.255.1	0	100	0	300 7018 7018 7018 1200 i
*>i192.168.3.0	10.255.255.1	0	100	0	300 7018 7018 7018 1200 i

5.3 BGP NLRI Advertisements

Configuration

```
R1#
router bgp 100
 network 10.20.0.0 mask 255.255.255.0
 network 10.20.1.0 mask 255.255.255.0
 network 10.20.2.0 mask 255.255.255.0
 network 10.20.3.0 mask 255.255.255.0
 network 10.50.0.0 mask 255.255.255.0
 network 10.50.1.0 mask 255.255.255.0
 network 10.50.2.0 mask 255.255.255.0
 network 10.50.3.0 mask 255.255.255.0
 network 10.50.4.0 mask 255.255.255.0
 network 10.50.5.0 mask 255.255.255.0
 network 10.50.6.0 mask 255.255.255.0
 network 10.50.7.0 mask 255.255.255.0
 network 10.100.7.0 mask 255.255.255.0
 network 10.100.8.0 mask 255.255.255.0
 network 10.100.9.0 mask 255.255.255.0
 network 10.100.10.0 mask 255.255.255.0
```

```
R4#
router bgp 100
 network 10.20.0.0 mask 255.255.255.0
 network 10.20.1.0 mask 255.255.255.0
 network 10.20.2.0 mask 255.255.255.0
 network 10.20.3.0 mask 255.255.255.0
 network 10.50.0.0 mask 255.255.255.0
 network 10.50.1.0 mask 255.255.255.0
 network 10.50.2.0 mask 255.255.255.0
 network 10.50.3.0 mask 255.255.255.0
 network 10.50.4.0 mask 255.255.255.0
 network 10.50.5.0 mask 255.255.255.0
 network 10.50.6.0 mask 255.255.255.0
 network 10.50.7.0 mask 255.255.255.0
 network 10.100.7.0 mask 255.255.255.0
 network 10.100.8.0 mask 255.255.255.0
 network 10.100.9.0 mask 255.255.255.0
 network 10.100.10.0 mask 255.255.255.0
```

Verification

```
R1#show ip bgp regexp ^$
BGP table version is 65, local router ID is 10.255.255.1
Status codes: s suppressed, d damped, h history, * valid, > best, i -
internal,
                r RIB-failure, S Stale
Origin codes: i - IGP, e - EGP, ? - incomplete
```

	Network	Next Hop	Metric	LocPrf	Weight	Path
* >	i10.20.0.0/24	10.255.255.4	2172416	100	0	i
* >		10.0.0.2	2172416		32768	i
* >	i10.20.1.0/24	10.255.255.4	2172416	100	0	i
* >		10.0.0.2	2172416		32768	i
* >	i10.20.2.0/24	10.255.255.4	2172416	100	0	i
* >		10.0.0.2	2172416		32768	i
* >	i10.20.3.0/24	10.255.255.4	2172416	100	0	i
* >		10.0.0.2	2172416		32768	i
* >	i10.50.0.0/24	10.255.255.4	2172416	100	0	i
* >		10.0.0.3	2172416		32768	i
* >	i10.50.1.0/24	10.255.255.4	2172416	100	0	i
* >		10.0.0.3	2172416		32768	i
* >	i10.50.2.0/24	10.255.255.4	2172416	100	0	i
* >		10.0.0.3	2172416		32768	i
* >	i10.50.3.0/24	10.255.255.4	2172416	100	0	i
* >		10.0.0.3	2172416		32768	i
* >	i10.50.4.0/24	10.255.255.4	2172416	100	0	i
* >		10.0.0.3	2172416		32768	i
* >	i10.50.5.0/24	10.255.255.4	2172416	100	0	i
* >		10.0.0.3	2172416		32768	i
* >	i10.50.6.0/24	10.255.255.4	2172416	100	0	i
* >		10.0.0.3	2172416		32768	i
* >	i10.50.7.0/24	10.255.255.4	2172416	100	0	i
* >		10.0.0.3	2172416		32768	i
* >	i10.100.7.0/24	10.255.255.4	30976	100	0	i
* >		10.100.17.7	28416		32768	i
* >	i10.100.8.0/24	10.255.255.4	28416	100	0	i
* >		10.100.17.7	30976		32768	i
* >	i10.100.9.0/24	10.255.255.4	33536	100	0	i
* >		10.100.17.7	30976		32768	i
* >	i10.100.10.0/24	10.255.255.4	30976	100	0	i
* >		10.100.17.7	33536		32768	i

5.4 BGP Aggregation

Configuration

R1#

```
router bgp 100
  aggregate-address 10.20.0.0 255.255.252.0 summary-only
  aggregate-address 10.50.0.0 255.255.248.0 summary-only
  aggregate-address 10.100.8.0 255.255.254.0 summary-only
```

R4#

```
router bgp 100
  aggregate-address 10.20.0.0 255.255.252.0 summary-only
  aggregate-address 10.50.0.0 255.255.248.0 summary-only
  aggregate-address 10.100.8.0 255.255.254.0 summary-only
```

Verification

R1#show ip bgp regexp ^\$

BGP table version is 82, local router ID is 10.255.255.1

Status codes: s suppressed, d damped, h history, * valid, > best, i - internal,

r RIB-failure, S Stale

Origin codes: i - IGP, e - EGP, ? - incomplete

Network	Next Hop	Metric	LocPrf	Weight	Path
s> 10.20.0.0/24	10.0.0.2	2172416		32768	i
* i10.20.0.0/22	10.255.255.4	0	100	0	i
*>	0.0.0.0			32768	i
s> 10.20.1.0/24	10.0.0.2	2172416		32768	i
s> 10.20.2.0/24	10.0.0.2	2172416		32768	i
s> 10.20.3.0/24	10.0.0.2	2172416		32768	i
s> 10.50.0.0/24	10.0.0.3	2172416		32768	i
* i10.50.0.0/21	10.255.255.4	0	100	0	i
*>	0.0.0.0			32768	i
s> 10.50.1.0/24	10.0.0.3	2172416		32768	i
s> 10.50.2.0/24	10.0.0.3	2172416		32768	i
s> 10.50.3.0/24	10.0.0.3	2172416		32768	i
s> 10.50.4.0/24	10.0.0.3	2172416		32768	i
s> 10.50.5.0/24	10.0.0.3	2172416		32768	i
s> 10.50.6.0/24	10.0.0.3	2172416		32768	i
s> 10.50.7.0/24	10.0.0.3	2172416		32768	i
* i10.100.7.0/24	10.255.255.4	30976	100	0	i
*>	10.100.17.7	28416		32768	i
s> 10.100.8.0/24	10.100.17.7	30976		32768	i
* i10.100.8.0/23	10.255.255.4	0	100	0	i
*>	0.0.0.0			32768	i
s> 10.100.9.0/24	10.100.17.7	30976		32768	i
* i10.100.10.0/24	10.255.255.4	30976	100	0	i
*>	10.100.17.7	33536		32768	i

R3#show ip bgp regexp ^100\$

BGP table version is 150, local router ID is 172.16.36.3

Status codes: s suppressed, d damped, h history, * valid, > best, i - internal,

r RIB-failure, S Stale

Origin codes: i - IGP, e - EGP, ? - incomplete

Network	Next Hop	Metric	LocPrf	Weight	Path
*> 10.20.0.0/22	172.16.13.1	0		0	100 i
*> 10.50.0.0/21	172.16.13.1	0		0	100 i
*> 10.100.7.0/24	172.16.13.1	28416		0	100 i
*> 10.100.8.0/23	172.16.13.1	0		0	100 i
*> 10.100.10.0/24	172.16.13.1	33536		0	100 i

5.5 Outbound BGP Path Selection

Configuration

```
R4#
route-map LOCAL_PREFERENCE
  set local-preference 1000
!
router bgp 100
  neighbor 172.16.46.6 route-map LOCAL_PREFERENCE in
```

Verification

Note

Before modifying path selection, some destinations are routed via R1's link to R3:

```
R1#show ip bgp 1.0.0.0
BGP routing table entry for 1.0.0.0/10, version 37
Paths: (1 available, best #1, table Default-IP-Routing-Table)
  Advertised to update-groups:
    1
    300
    172.16.13.3 from 172.16.13.3 (172.16.36.3)
      Origin incomplete, metric 0, localpref 100, valid, external, best
```

Afterwards, all prefixes are routed via R4 due to the higher local preference:

```
R1#show ip bgp 1.0.0.0
BGP routing table entry for 1.0.0.0/10, version 98
Paths: (2 available, best #1, table Default-IP-Routing-Table)
Flag: 0x820
  Advertised to update-groups:
    2
    600 300
    10.255.255.4 (metric 161280) from 10.255.255.4 (10.255.255.4)
      Origin incomplete, metric 0, localpref 1000, valid, internal, best
    300
    172.16.13.3 from 172.16.13.3 (172.16.36.3)
      Origin incomplete, metric 0, localpref 100, valid, external
```

5.6 Inbound BGP Path Selection

Configuration

```
R1#
route-map AS_PATH
  set as-path prepend 100 100 100 100 100
!
router bgp 100
  neighbor 172.16.13.3 route-map AS_PATH out
```

Verification

Note

Prior to modifying path selection, R3 uses R1 to reach the AS 100 routes.

```
R3#show ip bgp regexp _100$
```

```
BGP table version is 150, local router ID is 172.16.36.3
Status codes: s suppressed, d damped, h history, * valid, > best, i - internal,
               r RIB-failure, S Stale
Origin codes: i - IGP, e - EGP, ? - incomplete
```

Network	Next Hop	Metric	LocPrf	Weight	Path
*> 10.20.0.0/22	172.16.13.1	0	0	100	i
*	172.16.36.6		0	600	100 i
*> 10.50.0.0/21	172.16.13.1	0	0	100	i
*	172.16.36.6		0	600	100 i
*> 10.100.7.0/24	172.16.13.1	28416	0	100	i
*	172.16.36.6		0	600	100 i
*> 10.100.8.0/23	172.16.13.1	0	0	100	i
*	172.16.36.6		0	600	100 i
*> 10.100.10.0/24	172.16.13.1	33536	0	100	i
*	172.16.36.6		0	600	100 i

Afterwards, R4 is used since the routes via R1 have a longer AS-Path.

```
R3#show ip bgp regexp _100$
```

```
BGP table version is 155, local router ID is 172.16.36.3
Status codes: s suppressed, d damped, h history, * valid, > best, i - internal,
               r RIB-failure, S Stale
Origin codes: i - IGP, e - EGP, ? - incomplete
```

Network	Next Hop	Metric	LocPrf	Weight	Path
* 10.20.0.0/22	172.16.13.1	0	0	100	100 100 100 100 100 i
*>	172.16.36.6		0	600	100 i
* 10.50.0.0/21	172.16.13.1	0	0	100	100 100 100 100 100 i
*>	172.16.36.6		0	600	100 i
* 10.100.7.0/24	172.16.13.1	28416	0	100	100 100 100 100 100 i
*>	172.16.36.6		0	600	100 i
* 10.100.8.0/23	172.16.13.1	0	0	100	100 100 100 100 100 i
*>	172.16.36.6		0	600	100 i
* 10.100.10.0/24	172.16.13.1	33536	0	100	100 100 100 100 100 i
*>	172.16.36.6		0	600	100 i

6.1 PIM

Configuration

```
R1#
ip multicast-routing
!
ip pim rp-address 10.255.255.1
!
interface FastEthernet0/0
 ip pim sparse-dense-mode
!
interface Serial0/0
 ip pim sparse-dense-mode
!
interface Loopback0
 ip pim sparse-dense-mode
```

```
R2#
ip multicast-routing
!
ip pim rp-address 10.255.255.1
!
interface FastEthernet0/0.200
 ip pim sparse-dense-mode
!
interface FastEthernet0/0.201
 ip pim sparse-dense-mode
!
interface FastEthernet0/0.202
 ip pim sparse-dense-mode
!
interface FastEthernet0/0.203
 ip pim sparse-dense-mode
!
interface Serial0/0.201
 ip pim sparse-dense-mode
!
interface Serial0/0.204
 ip pim sparse-dense-mode
```

```
R4#
ip multicast-routing
!
ip pim rp-address 10.255.255.1
!
interface FastEthernet0/0
 ip pim sparse-dense-mode
!
interface FastEthernet0/1
 ip pim sparse-dense-mode
!
interface Serial0/0/0
 ip pim sparse-dense-mode
```

```
R5#
ip multicast-routing
!
ip pim rp-address 10.255.255.1
!
interface FastEthernet0/0.500
 ip pim sparse-dense-mode
!
interface FastEthernet0/0.501
 ip pim sparse-dense-mode
!
interface FastEthernet0/0.502
 ip pim sparse-dense-mode
!
interface FastEthernet0/0.503
 ip pim sparse-dense-mode
!
interface FastEthernet0/0.504
 ip pim sparse-dense-mode
!
interface FastEthernet0/0.505
 ip pim sparse-dense-mode
!
interface FastEthernet0/0.506
 ip pim sparse-dense-mode
!
interface FastEthernet0/0.507
 ip pim sparse-dense-mode
!
interface Serial0/0/0.501
 ip pim sparse-dense-mode
!
interface Serial0/0/0.504
 ip pim sparse-dense-mode

SW1#
ip multicast-routing distributed
!
ip pim rp-address 10.255.255.1
!
interface Vlan7
 ip pim sparse-dense-mode
!
interface FastEthernet0/1
 ip pim sparse-dense-mode
!
interface FastEthernet0/19
 ip pim sparse-dense-mode
!
interface Port-channel12
 ip pim sparse-dense-mode
!
interface Port-channel13
 ip pim sparse-dense-mode
```

```
SW2#
ip multicast-routing distributed
!
ip pim rp-address 10.255.255.1
!
interface Vlan8
 ip pim sparse-dense-mode
!
interface FastEthernet0/4
 ip pim sparse-dense-mode
!
interface FastEthernet0/16
 ip pim sparse-dense-mode
!
interface Port-channel12
 ip pim sparse-dense-mode
!
interface Port-channel24
 ip pim sparse-dense-mode
```

```
SW3#
ip multicast-routing
!
ip pim rp-address 10.255.255.1
!
interface Vlan9
 ip pim sparse-dense-mode
!
interface FastEthernet0/16
 ip pim sparse-dense-mode
!
interface Port-channel13
 ip pim sparse-dense-mode
```

```
SW4#
ip multicast-routing
!
ip pim rp-address 10.255.255.1
!
interface Vlan10
 ip pim sparse-dense-mode
!
interface FastEthernet0/13
 ip pim sparse-dense-mode
!
interface Port-channel24
 ip pim sparse-dense-mode
```

Verification

R1#show ip pim interface

Address	Interface	Ver/ Mode	Nbr Count	Query Intvl	DR Prior	DR
10.255.255.1	Loopback0	v2/SD	0	30	1	10.255.255.1
10.100.17.1	FastEthernet0/0	v2/SD	1	30	1	10.100.17.7
10.0.0.1	Serial0/0	v2/SD	2	30	1	10.0.0.3

R2#show ip pim interface

Address	Interface	Ver/ Mode	Nbr Count	Query Intvl	DR Prior	DR
10.20.0.2	FastEthernet0/0.200	v2/SD	0	30	1	10.20.0.2
10.20.1.2	FastEthernet0/0.201	v2/SD	0	30	1	10.20.1.2
10.20.2.2	FastEthernet0/0.202	v2/SD	0	30	1	10.20.2.2
10.20.3.2	FastEthernet0/0.203	v2/SD	0	30	1	10.20.3.2
10.0.0.2	Serial0/0.201	v2/SD	1	30	1	0.0.0.0
10.0.0.10	Serial0/0.204	v2/SD	1	30	1	0.0.0.0

R4#show ip pim interface

Address	Interface	Ver/ Mode	Nbr Count	Query Intvl	DR Prior	DR
10.100.48.4	FastEthernet0/0	v2/SD	1	30	1	10.100.48.8
172.16.46.4	FastEthernet0/1	v2/SD	0	30	1	0.0.0.0
10.0.0.9	Serial0/0/0	v2/SD	2	30	1	10.0.0.11

R5#show ip pim interface

Address	Interface	Ver/ Mode	Nbr Count	Query Intvl	DR Prior	DR
10.50.0.5	FastEthernet0/0.500	v2/SD	0	30	1	10.50.0.5
10.50.1.5	FastEthernet0/0.501	v2/SD	0	30	1	10.50.1.5
10.50.2.5	FastEthernet0/0.502	v2/SD	0	30	1	10.50.2.5
10.50.3.5	FastEthernet0/0.503	v2/SD	0	30	1	10.50.3.5
10.50.4.5	FastEthernet0/0.504	v2/SD	0	30	1	10.50.4.5
10.50.5.5	FastEthernet0/0.505	v2/SD	0	30	1	10.50.5.5
10.50.6.5	FastEthernet0/0.506	v2/SD	0	30	1	10.50.6.5
10.50.7.5	FastEthernet0/0.507	v2/SD	0	30	1	10.50.7.5
10.0.0.3	Serial0/0/0.501	v2/SD	1	30	1	0.0.0.0
10.0.0.11	Serial0/0/0.504	v2/SD	1	30	1	0.0.0.0

SW1#show ip pim interface

Address	Interface	Ver/ Mode	Nbr Count	Query Intvl	DR Prior	DR
10.100.7.7	Vlan7	v2/SD	0	30	1	10.100.7.7
10.100.17.7	FastEthernet0/1	v2/SD	1	30	1	10.100.17.7
10.100.107.7	FastEthernet0/19	v2/SD	1	30	1	10.100.107.10
10.100.78.7	Port-channel12	v2/SD	1	30	1	10.100.78.8
10.100.79.7	Port-channel13	v2/SD	1	30	1	10.100.79.9

SW2#show ip pim interface

Address	Interface	Ver/ Mode	Nbr Count	Query Intvl	DR Prior	DR
10.100.8.8	Vlan8	v2/SD	0	30	1	10.100.8.8
10.100.48.8	FastEthernet0/4	v2/SD	1	30	1	10.100.48.8
10.100.89.8	FastEthernet0/16	v2/SD	1	30	1	10.100.89.9
10.100.78.8	Port-channel2	v2/SD	1	30	1	10.100.78.8
10.100.108.8	Port-channel24	v2/SD	1	30	1	10.100.108.10

SW3#show ip pim interface

Address	Interface	Ver/ Mode	Nbr Count	Query Intvl	DR Prior	DR
10.100.9.9	Vlan9	v2/SD	0	30	1	10.100.9.9
10.100.89.9	FastEthernet0/16	v2/SD	1	30	1	10.100.89.9
10.100.79.9	Port-channel13	v2/SD	1	30	1	10.100.79.9

SW4#show ip pim interface

Address	Interface	Ver/ Mode	Nbr Count	Query Intvl	DR Prior	DR
10.100.10.10	Vlan10	v2/SD	0	30	1	10.100.10.10
10.100.107.10	FastEthernet0/13	v2/SD	1	30	1	10.100.107.10
10.100.108.10	Port-channel24	v2/SD	1	30	1	10.100.108.10

R1#show ip pim neighbor

PIM Neighbor Table

Mode: B - Bidir Capable, DR - Designated Router, N - Default DR Priority,
S - State Refresh Capable

Neighbor Address	Interface	Uptime/Expires	Ver	DR Prio/Mode
10.100.17.7	FastEthernet0/0	00:06:12/00:01:26	v2	1 / DR S
10.0.0.3	Serial0/0	00:06:22/00:01:18	v2	1 / DR S
10.0.0.2	Serial0/0	00:06:39/00:01:28	v2	1 / S

R2#show ip pim neighbor

PIM Neighbor Table

Mode: B - Bidir Capable, DR - Designated Router, N - Default DR Priority,
S - State Refresh Capable

Neighbor Address	Interface	Uptime/Expires	Ver	DR Prio/Mode
10.0.0.1	Serial0/0.201	00:06:41/00:01:44	v2	1 / S
10.0.0.9	Serial0/0.204	00:06:33/00:01:44	v2	1 / S

R4#show ip pim neighbor

PIM Neighbor Table

Mode: B - Bidir Capable, DR - Designated Router, N - Default DR Priority,
S - State Refresh Capable

Neighbor Address	Interface	Uptime/Expires	Ver	DR Prio/Mode
10.100.48.8	FastEthernet0/0	00:06:07/00:01:32	v2	1 / DR S P
10.0.0.11	Serial0/0/0	00:06:26/00:01:42	v2	1 / DR S P
10.0.0.10	Serial0/0/0	00:06:35/00:01:31	v2	1 / S

R5#show ip pim neighbor

```
PIM Neighbor Table
Mode: B - Bidir Capable, DR - Designated Router, N - Default DR Priority,
      S - State Refresh Capable
Neighbor      Interface      Uptime/Expires      Ver      DR
Address
10.0.0.1      Serial0/0/0.501      00:06:27/00:01:40  v2      1 / S
10.0.0.9      Serial0/0/0.504      00:06:27/00:01:40  v2      1 / S P
```

SW1#show ip pim neighbor

```
PIM Neighbor Table
Mode: B - Bidir Capable, DR - Designated Router, N - Default DR Priority,
      P - Proxy Capable, S - State Refresh Capable
Neighbor      Interface      Uptime/Expires      Ver      DR
Address
10.100.17.1   FastEthernet0/1      00:06:20/00:01:19  v2      1 / S
10.100.107.10 FastEthernet0/19      00:05:41/00:01:28  v2      1 / DR S P
10.100.78.8   Port-channel12       00:06:11/00:01:28  v2      1 / DR S P
10.100.79.9   Port-channel13       00:06:02/00:01:36  v2      1 / DR S P
```

SW2#show ip pim neighbor

```
PIM Neighbor Table
Mode: B - Bidir Capable, DR - Designated Router, N - Default DR Priority,
      P - Proxy Capable, S - State Refresh Capable
Neighbor      Interface      Uptime/Expires      Ver      DR
Address
10.100.48.4   FastEthernet0/4      00:06:12/00:01:27  v2      1 / S P
10.100.89.9   FastEthernet0/16     00:06:03/00:01:36  v2      1 / DR S P
10.100.78.7   Port-channel12       00:06:12/00:01:26  v2      1 / S P
10.100.108.10 Port-channel24       00:05:43/00:01:26  v2      1 / DR S P
```

SW3#show ip pim neighbor

```
PIM Neighbor Table
Mode: B - Bidir Capable, DR - Designated Router, N - Default DR Priority,
      P - Proxy Capable, S - State Refresh Capable
Neighbor      Interface      Uptime/Expires      Ver      DR
Address
10.100.89.8   FastEthernet0/16     00:06:04/00:01:34  v2      1 / S P
10.100.79.7   Port-channel13       00:06:04/00:01:34  v2      1 / S P
```

SW4#show ip pim neighbor

```
PIM Neighbor Table
Mode: B - Bidir Capable, DR - Designated Router, N - Default DR Priority,
      P - Proxy Capable, S - State Refresh Capable
Neighbor      Interface      Uptime/Expires      Ver      DR
Address
10.100.107.7   FastEthernet0/13     00:05:46/00:01:23  v2      1 / S P
10.100.108.8   Port-channel24       00:05:46/00:01:23  v2      1 / S P
```

6.2 Multicast Testing

Configuration

```
R2#  
interface FastEthernet0/0.200  
 ip igmp join-group 224.1.2.3
```

Verification

```
SW1#ping 224.1.2.3 source 10.100.7.7
```

```
Type escape sequence to abort.  
Sending 1, 100-byte ICMP Echos to 224.1.2.3, timeout is 2 seconds:  
Packet sent with a source address of 10.100.7.7
```

```
Reply to request 0 from 10.0.0.10, 67 ms  
Reply to request 0 from 10.0.0.10, 92 ms  
Reply to request 0 from 10.0.0.10, 75 ms
```

```
R2#show ip mroute 224.1.2.3
```

```
IP Multicast Routing Table  
Flags: D - Dense, S - Sparse, B - Bidir Group, s - SSM Group, C - Connected,  
 L - Local, P - Pruned, R - RP-bit set, F - Register flag,  
 T - SPT-bit set, J - Join SPT, M - MSDP created entry,  
 X - Proxy Join Timer Running, A - Candidate for MSDP Advertisement,  
 U - URD, I - Received Source Specific Host Report,  
 Z - Multicast Tunnel, z - MDT-data group sender,  
 Y - Joined MDT-data group, y - Sending to MDT-data group  
Outgoing interface flags: H - Hardware switched, A - Assert winner  
Timers: Uptime/Expires  
Interface state: Interface, Next-Hop or VCD, State/Mode  
  
(* , 224.1.2.3), 00:00:17/stopped, RP 10.255.255.1, flags: SJCL  
 Incoming interface: Serial0/0.204, RPF nbr 10.0.0.9  
 Outgoing interface list:  
   FastEthernet0/0.200, Forward/Sparse-Dense, 00:00:17/00:02:47
```

```
(10.100.7.7, 224.1.2.3), 00:00:10/00:02:55, flags: LJT  
 Incoming interface: Serial0/0.204, RPF nbr 10.0.0.9  
 Outgoing interface list:  
   FastEthernet0/0.200, Forward/Sparse-Dense, 00:00:10/00:02:49
```

```
(10.100.17.7, 224.1.2.3), 00:00:11/00:02:54, flags: LJT  
 Incoming interface: Serial0/0.204, RPF nbr 10.0.0.9  
 Outgoing interface list:  
   FastEthernet0/0.200, Forward/Sparse-Dense, 00:00:11/00:02:48
```

```
(10.100.78.7, 224.1.2.3), 00:00:11/00:02:54, flags: LJT  
 Incoming interface: Serial0/0.204, RPF nbr 10.0.0.9  
 Outgoing interface list:  
   FastEthernet0/0.200, Forward/Sparse-Dense, 00:00:11/00:02:48
```

7.1 IPv6 Addressing

Configuration

```
R1#
ipv6 unicast-routing
!
interface FastEthernet0/0
  ipv6 address 2001:10:100:17::1/64
!
interface Loopback0
  ipv6 address 2001:10:255:255::1/128

R4#
ipv6 unicast-routing
!
interface FastEthernet0/0
  ipv6 address 2001:10:100:48::4/64
!
interface Loopback0
  ipv6 address 2001:10:255:255::4/128

SW1#
ipv6 unicast-routing
!
interface FastEthernet0/1
  ipv6 address 2001:10:100:17::7/64
!
interface Port-Channel12
  ipv6 address 2001:10:100:78::7/64
!
interface Vlan7
  ipv6 address 2001:10:100:7::7/64
!
interface Loopback0
  ipv6 address 2001:10:255:255::7/128

SW2#
ipv6 unicast-routing
!
interface FastEthernet0/4
  ipv6 address 2001:10:100:48::8/64
!
interface Port-Channel12
  ipv6 address 2001:10:100:78::8/64
!
interface Vlan8
  ipv6 address 2001:10:100:8::8/64
!
interface Loopback0
  ipv6 address 2001:10:255:255::8/128
```

Verification

Note

Prior to implementing IPv6 routing on certain Catalyst platforms, the SDM template must be modified in order to allow for memory to be allocated for the IPv6 process.

```
SW1#conf t
Enter configuration commands, one per line. End with CNTL/Z.
SW1(config)#ipv6 unicast-routing
      ^
% Invalid input detected at '^' marker.

SW1(config)#sdm prefer dual-ipv4-and-ipv6 routing
Changes to the running SDM preferences have been stored, but cannot take effect
until the next reload.
Use 'show sdm prefer' to see what SDM preference is currently active.
SW1(config)#end
SW1#wr
Building configuration...
[OK]
SW1#reload
Proceed with reload? [confirm]

R1#show ipv6 interface brief
FastEthernet0/0          [up/up]
    FE80::20D:BDF6:FEF6:2F80
    2001:10:100:17::1
Serial10/0               [up/up]
Serial10/1               [administratively down/down]
Loopback0                [up/up]
    FE80::20D:BDF6:FEF6:2F80
    2001:10:255:255::1

R4#show ipv6 interface brief
FastEthernet0/0          [up/up]
    FE80::21B:D4FF:FE47:37B0
    2001:10:100:48::4
FastEthernet0/1          [administratively down/down]
    unassigned
Serial10/0/0             [up/up]
    unassigned
Serial10/1/0             [administratively down/down]
    unassigned
SSLVPN-VIF0              [up/up]
    unassigned
Loopback0                [up/up]
    FE80::21B:D4FF:FE47:37B0
    2001:10:255:255::4
```

SW1#show ipv6 interface brief

```
Vlan1 [administratively down/down]
  unassigned
Vlan7 [up/up]
  FE80::21B:D5FF:FE2B:CCCA
  2001:10:100:7::7
FastEthernet0/1 [up/up]
  FE80::21B:D5FF:FE2B:CCC3
  2001:10:100:17::7
<output omitted>
Port-channel12 [up/up]
  FE80::21B:D5FF:FE2B:CCC1
  2001:10:100:78::7
Port-channel13 [up/up]
  unassigned
Loopback0 [up/up]
  FE80::21B:D5FF:FE2B:CC80
  2001:10:255:255::7
```

SW2#show ipv6 interface brief

```
Vlan1 [administratively down/down]
  unassigned
Vlan8 [up/up]
  FE80::21D:A2FF:FE4B:D54A
  2001:10:100:8::8
FastEthernet0/1 [down/down]
  unassigned
FastEthernet0/2 [up/up]
  unassigned
FastEthernet0/3 [down/down]
  unassigned
FastEthernet0/4 [up/up]
  FE80::21D:A2FF:FE4B:D543
  2001:10:100:48::8
<output omitted>
Port-channel12 [up/up]
  FE80::21D:A2FF:FE4B:D541
  2001:10:100:78::8
Port-channel24 [up/up]
  unassigned
Loopback0 [up/up]
  FE80::21D:A2FF:FE4B:D500
  2001:10:255:255::8
```

7.2 IPv6 OSPFv3 Routing

Configuration

```
R1#
interface FastEthernet0/0
  ipv6 ospf 100 area 0
!
interface Loopback0
  ipv6 ospf 100 area 0
```

```
R4#
interface FastEthernet0/0
  ipv6 ospf 100 area 0
!
interface Loopback0
  ipv6 ospf 100 area 0
```

```
SW1#
interface FastEthernet0/1
  ipv6 ospf 100 area 0
!
interface Port-Channel12
  ipv6 ospf 100 area 0
!
interface Vlan7
  ipv6 ospf 100 area 0
!
interface Loopback0
  ipv6 ospf 100 area 0
```

```
SW2#
interface FastEthernet0/4
  ipv6 ospf 100 area 0
!
interface Port-Channel12
  ipv6 ospf 100 area 0
!
interface Vlan8
  ipv6 ospf 100 area 0
!
interface Loopback0
  ipv6 ospf 100 area 0
```

Verification

R1#show ipv6 ospf neighbor

Neighbor ID	Pri	State	Dead Time	Interface ID	Interface
10.255.255.7	1	FULL/BDR	00:00:31	467	FastEthernet0/0

R4#show ipv6 ospf neighbor

Neighbor ID	Pri	State	Dead Time	Interface ID	Interface
10.255.255.8	1	FULL/BDR	00:00:36	470	FastEthernet0/0

SW1#show ipv6 ospf neighbor

Neighbor ID	Pri	State	Dead Time	Interface ID	Interface
10.255.255.8	1	FULL/DR	00:00:34	608	Port-channell12
10.255.255.1	1	FULL/DR	00:00:31	4	FastEthernet0/1

SW2#show ipv6 ospf neighbor

Neighbor ID	Pri	State	Dead Time	Interface ID	Interface
10.255.255.7	1	FULL/BDR	00:00:33	608	Port-channell12
10.255.255.4	1	FULL/DR	00:00:39	4	FastEthernet0/4

R1#show ipv6 route

```
IPv6 Routing Table - 12 entries
Codes: C - Connected, L - Local, S - Static, R - RIP, B - BGP
       U - Per-user Static route
       I1 - ISIS L1, I2 - ISIS L2, IA - ISIS interarea, IS - ISIS summary
       O - OSPF intra, OI - OSPF inter, OE1 - OSPF ext 1, OE2 - OSPF ext 2
       ON1 - OSPF NSSA ext 1, ON2 - OSPF NSSA ext 2
O   2001:10:100:7::/64 [110/2]
    via FE80::21B:D5FF:FE2B:CCC3, FastEthernet0/0
O   2001:10:100:8::/64 [110/3]
    via FE80::21B:D5FF:FE2B:CCC3, FastEthernet0/0
C   2001:10:100:17::/64 [0/0]
    via ::, FastEthernet0/0
L   2001:10:100:17::1/128 [0/0]
    via ::, FastEthernet0/0
O   2001:10:100:48::/64 [110/3]
    via FE80::21B:D5FF:FE2B:CCC3, FastEthernet0/0
O   2001:10:100:78::/64 [110/2]
    via FE80::21B:D5FF:FE2B:CCC3, FastEthernet0/0
LC  2001:10:255:255::1/128 [0/0]
    via ::, Loopback0
O   2001:10:255:255::4/128 [110/3]
    via FE80::21B:D5FF:FE2B:CCC3, FastEthernet0/0
O   2001:10:255:255::7/128 [110/1]
    via FE80::21B:D5FF:FE2B:CCC3, FastEthernet0/0
O   2001:10:255:255::8/128 [110/2]
    via FE80::21B:D5FF:FE2B:CCC3, FastEthernet0/0
L   FE80::/10 [0/0]
    via ::, Null0
L   FF00::/8 [0/0]
    via ::, Null0
```

R4#show ipv6 route

```
IPv6 Routing Table - Default - 11 entries
Codes: C - Connected, L - Local, S - Static, U - Per-user Static route
       B - BGP, M - MIPv6, R - RIP, I1 - ISIS L1
       I2 - ISIS L2, IA - ISIS interarea, IS - ISIS summary, D - EIGRP
       EX - EIGRP external
       O - OSPF Intra, OI - OSPF Inter, OE1 - OSPF ext 1, OE2 - OSPF ext 2
       ON1 - OSPF NSSA ext 1, ON2 - OSPF NSSA ext 2
O  2001:10:100:7::/64 [110/3]
   via FE80::21D:A2FF:FE4B:D543, FastEthernet0/0
O  2001:10:100:8::/64 [110/2]
   via FE80::21D:A2FF:FE4B:D543, FastEthernet0/0
O  2001:10:100:17::/64 [110/3]
   via FE80::21D:A2FF:FE4B:D543, FastEthernet0/0
C  2001:10:100:48::/64 [0/0]
   via FastEthernet0/0, directly connected
L  2001:10:100:48::4/128 [0/0]
   via FastEthernet0/0, receive
O  2001:10:100:78::/64 [110/2]
   via FE80::21D:A2FF:FE4B:D543, FastEthernet0/0
O  2001:10:255:255::1/128 [110/3]
   via FE80::21D:A2FF:FE4B:D543, FastEthernet0/0
LC 2001:10:255:255::4/128 [0/0]
   via Loopback0, receive
O  2001:10:255:255::7/128 [110/2]
   via FE80::21D:A2FF:FE4B:D543, FastEthernet0/0
O  2001:10:255:255::8/128 [110/1]
   via FE80::21D:A2FF:FE4B:D543, FastEthernet0/0
L  FF00::/8 [0/0]
   via Null0, receive
```

SW1#show ipv6 route

```
IPv6 Routing Table - Default - 13 entries
Codes: C - Connected, L - Local, S - Static, U - Per-user Static route
       R - RIP, D - EIGRP, EX - EIGRP external
       O - OSPF Intra, OI - OSPF Inter, OE1 - OSPF ext 1, OE2 - OSPF ext 2
       ON1 - OSPF NSSA ext 1, ON2 - OSPF NSSA ext 2
C  2001:10:100:7::/64 [0/0]
   via Vlan7, directly connected
L  2001:10:100:7::7/128 [0/0]
   via Vlan7, receive
O  2001:10:100:8::/64 [110/2]
   via FE80::21D:A2FF:FE4B:D541, Port-channel12
C  2001:10:100:17::/64 [0/0]
   via FastEthernet0/1, directly connected
L  2001:10:100:17::7/128 [0/0]
   via FastEthernet0/1, receive
O  2001:10:100:48::/64 [110/2]
   via FE80::21D:A2FF:FE4B:D541, Port-channel12
C  2001:10:100:78::/64 [0/0]
   via Port-channel12, directly connected
L  2001:10:100:78::7/128 [0/0]
   via Port-channel12, receive
O  2001:10:255:255::1/128 [110/1]
   via FE80::20D:BDFF:FEF6:2F80, FastEthernet0/1
O  2001:10:255:255::4/128 [110/2]
   via FE80::21D:A2FF:FE4B:D541, Port-channel12
LC 2001:10:255:255::7/128 [0/0]
   via Loopback0, receive
O  2001:10:255:255::8/128 [110/1]
   via FE80::21D:A2FF:FE4B:D541, Port-channel12
L  FF00::/8 [0/0]
   via Null0, receive
```

SW2#show ipv6 route

```
IPv6 Routing Table - Default - 13 entries
Codes: C - Connected, L - Local, S - Static, U - Per-user Static route
       R - RIP, D - EIGRP, EX - EIGRP external
       O - OSPF Intra, OI - OSPF Inter, OE1 - OSPF ext 1, OE2 - OSPF ext 2
       ON1 - OSPF NSSA ext 1, ON2 - OSPF NSSA ext 2
O   2001:10:100:7::/64 [110/2]
    via FE80::21B:D5FF:FE2B:CCC1, Port-channel12
C   2001:10:100:8::/64 [0/0]
    via Vlan8, directly connected
L   2001:10:100:8::8/128 [0/0]
    via Vlan8, receive
O   2001:10:100:17::/64 [110/2]
    via FE80::21B:D5FF:FE2B:CCC1, Port-channel12
C   2001:10:100:48::/64 [0/0]
    via FastEthernet0/4, directly connected
L   2001:10:100:48::8/128 [0/0]
    via FastEthernet0/4, receive
C   2001:10:100:78::/64 [0/0]
    via Port-channel12, directly connected
L   2001:10:100:78::8/128 [0/0]
    via Port-channel12, receive
O   2001:10:255:255::1/128 [110/2]
    via FE80::21B:D5FF:FE2B:CCC1, Port-channel12
O   2001:10:255:255::4/128 [110/1]
    via FE80::21B:D4FF:FE47:37B0, FastEthernet0/4
O   2001:10:255:255::7/128 [110/1]
    via FE80::21B:D5FF:FE2B:CCC1, Port-channel12
LC  2001:10:255:255::8/128 [0/0]
    via Loopback0, receive
L   FF00::/8 [0/0]
    via Null0, receive
```

R1#ping 2001:10:255:255::4

```
Type escape sequence to abort.
Sending 5, 100-byte ICMP Echos to 2001:10:255:255::4, timeout is 2 seconds:
!!!!
Success rate is 100 percent (5/5), round-trip min/avg/max = 0/2/8 ms
```

R1#traceroute 2001:10:255:255::4

```
Type escape sequence to abort.
Tracing the route to 2001:10:255:255::4

 1 2001:10:100:17::7 4 msec 4 msec 4 msec
 2 2001:10:100:78::8 4 msec 4 msec 0 msec
 3 2001:10:100:48::4 4 msec 0 msec 4 msec
```

