

## PROGRAMMABLE VOLTAGE REFERENCE

- ADJUSTABLE OUTPUT VOLTAGE :  
V<sub>ref</sub> to 36V
- SINK CURRENT CAPABILITY : 1 to 100mA
- TYPICAL OUTPUT IMPEDANCE : 0.22Ω
- 1% AND 2% VOLTAGE PRECISION

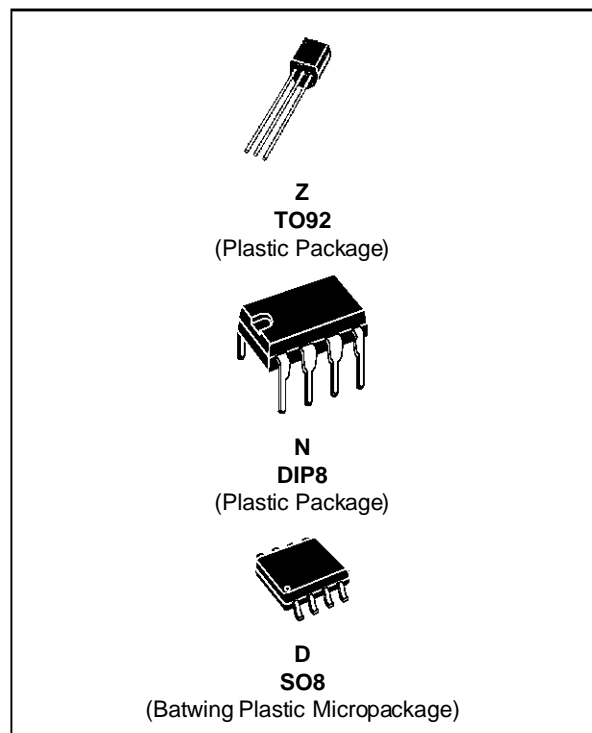

### DESCRIPTION

The TL431 is a programmable shunt voltage reference with guaranteed temperature stability over the entire temperature range of operation.

The output voltage may be set to any value between V<sub>ref</sub> (approximately 2.5V) and 36V with two external resistors.

The TL431 operates with a wide current range from 1 to 100mA with a typical dynamic impedance of 0.22Ω.

### ORDER CODES

Part number	Temperature Range	Package		
		Z	N	D
TL431C/AC	0°C, +70°C	•	•	•
TL431I/AI	-40°C, +85°C	•	•	•

### PIN CONNECTIONS

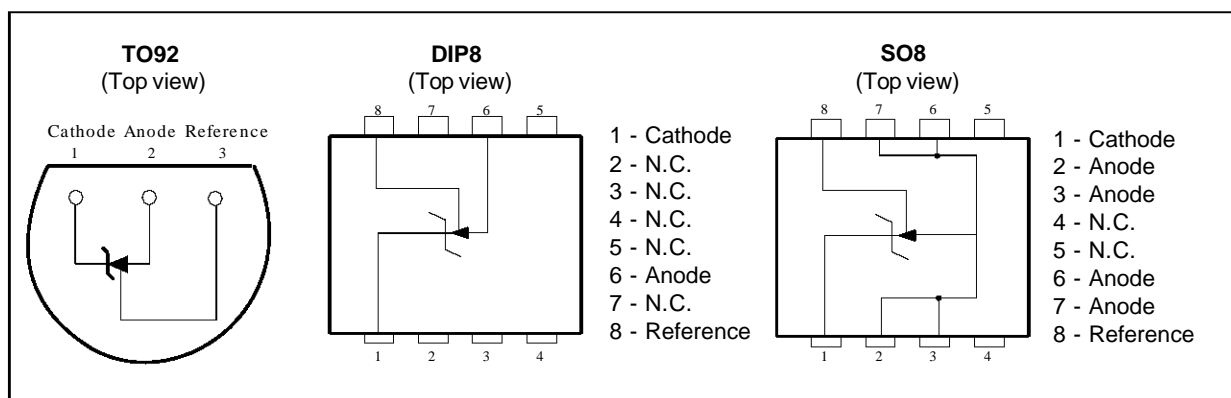

**ABSOLUTE MAXIMUM RATINGS**

Symbol	Parameter	Value	Unit
V <sub>KA</sub>	Cathode to Anode Voltage	37	V
I <sub>K</sub>	Continuous Cathode Current Range	-100 to +150	mA
I <sub>ref</sub>	Reference Input Current Range	-0.05 to +10	mA
T <sub>oper</sub>	Operating Free-air Temperature Range	TL431C/AC TL431I/AI 0 to +70 -40 to +85	°C
T <sub>stg</sub>	Storage Temperature Range	-65 to +150	°C

**OPERATING CONDITIONS**

Symbol	Parameter	Value	Unit
V <sub>KA</sub>	Cathode to Anode Voltage	V <sub>ref</sub> to 36	V
I <sub>K</sub>	Cathode Current	1 to 100	mA

**ELECTRICAL CHARACTERISTICS**

T<sub>amb</sub> = 25°C (unless otherwise specified)

Symbol	Parameter	TL431C			TL431AC			Unit
		Min.	Typ.	Max.	Min.	Typ.	Max.	
V <sub>ref</sub>	Reference Input Voltage - (figure 1) V <sub>KA</sub> = V <sub>ref</sub> , I <sub>K</sub> = 10mA T <sub>amb</sub> = 25°C T <sub>min.</sub> ≤ T <sub>amb</sub> ≤ T <sub>max.</sub>	2.44 2.423	2.495	2.55 2.567	2.47 2.453	2.495	2.52 2.537	V
ΔV <sub>ref</sub>	Reference Input Voltage Deviation Over Temperature Range - (figure 1, note 1) V <sub>KA</sub> = V <sub>ref</sub> , I <sub>K</sub> = 10mA, T <sub>min.</sub> ≤ T <sub>amb</sub> ≤ T <sub>max.</sub>		3	17		3	15	mV
$\frac{\Delta V_{ref}}{\Delta V_{KA}}$	Ratio of Change in Reference Input Voltage to Change in Cathode to Anode Voltage - (figure 2) I <sub>K</sub> = 10mA ΔV <sub>KA</sub> = 10V to V <sub>ref</sub> ΔV <sub>KA</sub> = 36V to 10V		-1.4 -1	-2.7 -2		-1.4 -1	-2.7 -2	mV/V
I <sub>ref</sub>	Reference Input Current - (figure 2) I <sub>K</sub> = 10mA, R <sub>1</sub> = 10kΩ, R <sub>2</sub> = ∞ T <sub>amb</sub> = 25°C T <sub>min.</sub> ≤ T <sub>amb</sub> ≤ T <sub>max.</sub>		1.8	4 5.2		1.8	4 5.2	μA
ΔI <sub>ref</sub>	Reference Input Current Deviation Over Temperature Range - (figure 2) I <sub>K</sub> = 10mA, R <sub>1</sub> = 10kΩ, R <sub>2</sub> = ∞ T <sub>min.</sub> ≤ T <sub>amb</sub> ≤ T <sub>max.</sub>		0.4	1.2		0.4	1.2	μA
I <sub>min</sub>	Minimum Cathode Current for Regulation - (figure 1) V <sub>KA</sub> = V <sub>ref</sub>		0.5	1		0.5	0.6	mA
I <sub>off</sub>	Off-State Cathode Current - (figure 3)		2.6	1000		2.6	1000	nA
Z <sub>KA</sub>	Dynamic Impedance - (figure 1, note 2) V <sub>KA</sub> = V <sub>ref</sub> , ΔI <sub>K</sub> = 1 to 100mA, f ≤ 1kHz		0.22	0.5		0.22	0.5	Ω

Notes : 1. ΔV<sub>ref</sub> is defined as the difference between the maximum and minimum values obtained over the full temperature range.

ΔV<sub>ref</sub> = V<sub>ref max.</sub> - V<sub>ref min.</sub>

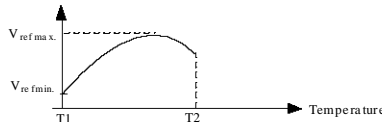

2. The dynamic Impedance is defined as  $|Z_{KA}| = \frac{\Delta V_{KA}}{\Delta I_K}$

**ELECTRICAL CHARACTERISTICS**

T<sub>amb</sub> = 25°C (unless otherwise specified)

Symbol	Parameter	TL431I			TL431AI			Unit
		Min.	Typ.	Max.	Min.	Typ.	Max.	
V <sub>ref</sub>	Reference Input Voltage - (figure 1) V <sub>KA</sub> = V <sub>ref</sub> , I <sub>K</sub> = 10mA T <sub>amb</sub> = 25°C T <sub>min.</sub> ≤ T <sub>amb</sub> ≤ T <sub>max.</sub>	2.44 2.41	2.495	2.55 2.58	2.47 2.44	2.495	2.52 2.55	V
ΔV <sub>ref</sub>	Reference Input Voltage Deviation Over Temperature Range - (figure 1, note 1) V <sub>KA</sub> = V <sub>ref</sub> , I <sub>K</sub> = 10mA, T <sub>min.</sub> ≤ T <sub>amb</sub> ≤ T <sub>max.</sub>		7	30		7	30	mV
$\frac{\Delta V_{ref}}{\Delta V_{KA}}$	Ratio of Change in Reference Input Voltage to Change in Cathode to Anode Voltage - (figure 2) I <sub>K</sub> = 10mA ΔV <sub>KA</sub> = 10V to V <sub>ref</sub> ΔV <sub>KA</sub> = 36V to 10V		-1.4 -1	-2.7 -2		-1.4 -1	-2.7 -2	mV/V
I <sub>ref</sub>	Reference Input Current - (figure 2) I <sub>K</sub> = 10mA, R <sub>1</sub> = 10kΩ, R <sub>2</sub> = ∞ T <sub>amb</sub> = 25°C T <sub>min.</sub> ≤ T <sub>amb</sub> ≤ T <sub>max.</sub>		1.8	4 6.5		1.8	4 6.5	μA
ΔI <sub>ref</sub>	Reference Input Current Deviation Over Temperature Range - (figure 2) I <sub>K</sub> = 10mA, R <sub>1</sub> = 10kΩ, R <sub>2</sub> = ∞ T <sub>min.</sub> ≤ T <sub>amb</sub> ≤ T <sub>max.</sub>		0.8	2.5		0.8	1.2	μA
I <sub>min</sub>	Minimum Cathode Current for Regulation - (figure 1) V <sub>KA</sub> = V <sub>ref</sub>		0.5	1		0.5	0.7	mA
I <sub>off</sub>	Off-State Cathode Current - (figure 3)		2.6	1000		2.6	1000	nA
Z <sub>KA</sub>	Dynamic Impedance - (figure 1, note 2) V <sub>KA</sub> = V <sub>ref</sub> , ΔI <sub>K</sub> = 1 to 100mA, f ≤ 1kHz		0.22	0.5		0.22	0.5	Ω

Notes : 1. ΔV<sub>ref</sub> is defined as the difference between the maximum and minimum values obtained over the full temperature range.

$$\Delta V_{ref} = V_{ref \max} - V_{ref \min}$$

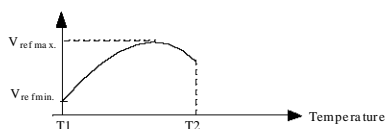

2. The dynamic Impedance is defined as  $|Z_{KA}| = \frac{\Delta V_{KA}}{\Delta I_K}$

Figure 1 : Test Circuit for  $V_{KA} = V_{ref}$

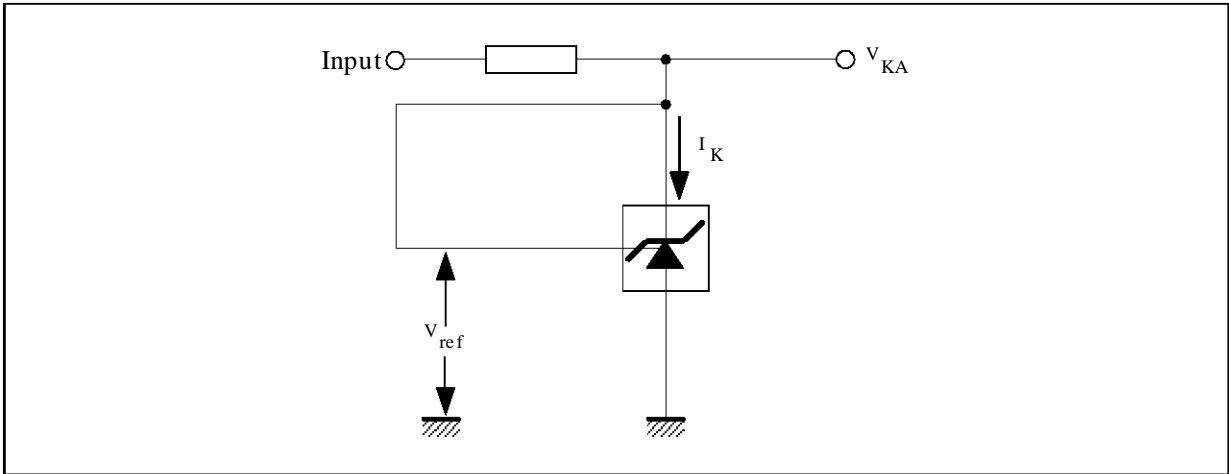

Figure 2 : Test Circuit for  $V_{KA} > V_{ref}$

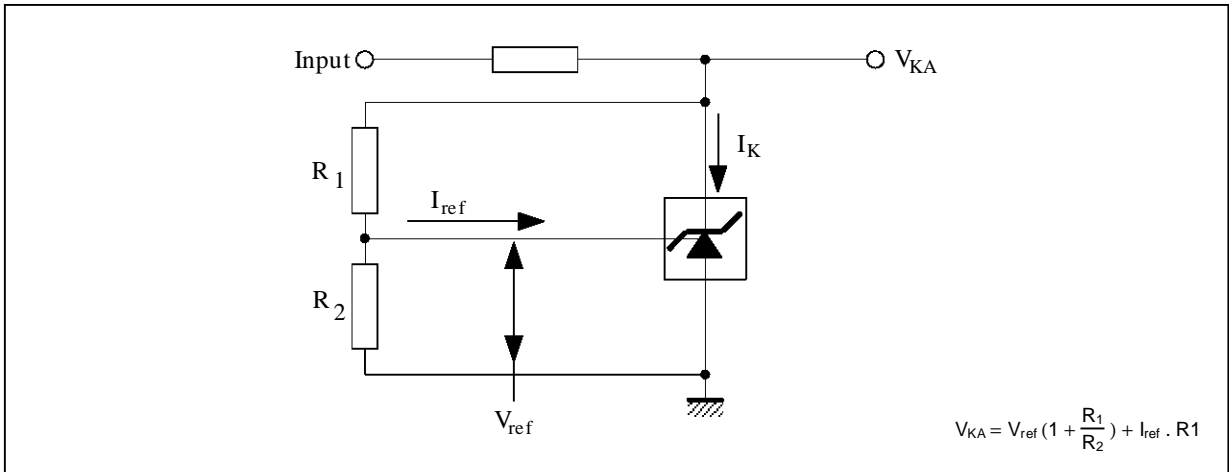
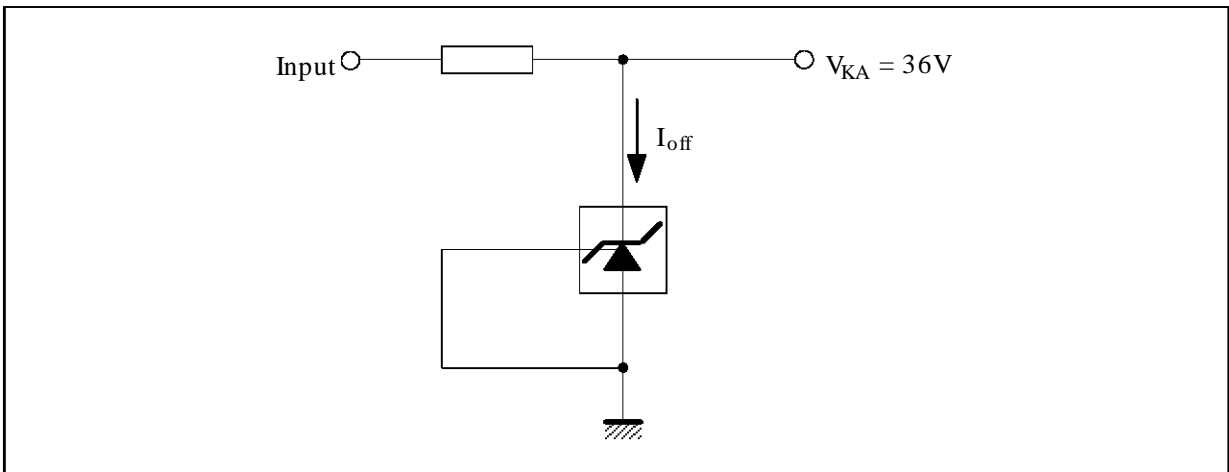
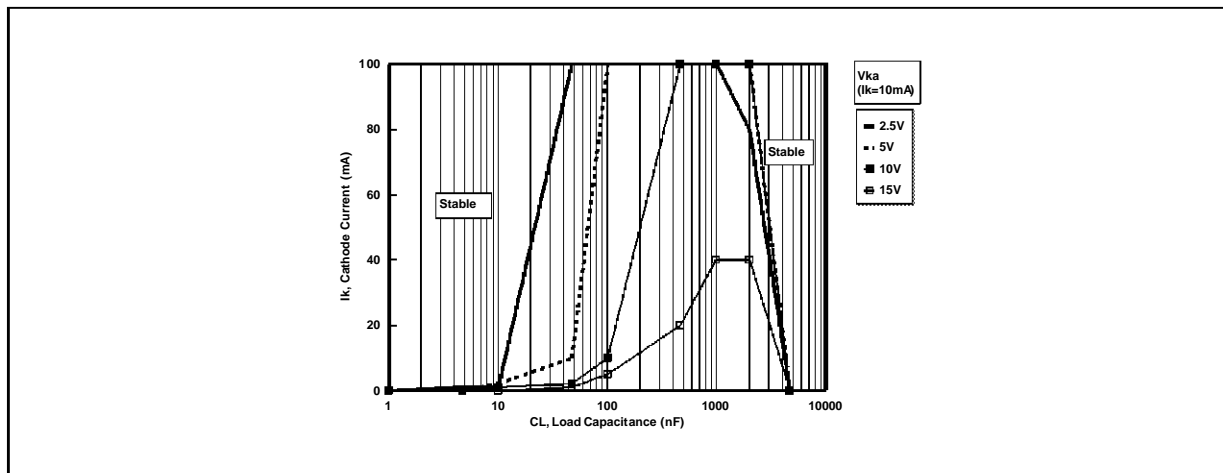

Figure 3 : Test Circuit for  $I_{off}$



STABILITY BOUNDARY CONDITIONS



OPEN LOOP VOLTAGE GAIN VERSUS FREQUENCY

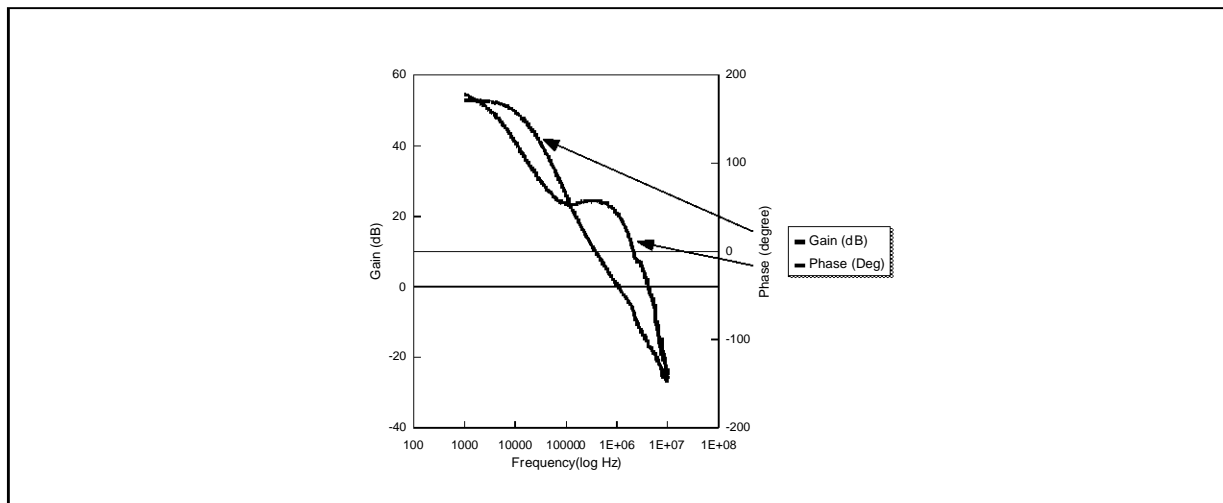

REFERENCE INPUT VOLTAGE VERSUS CATHODE VOLTAGE

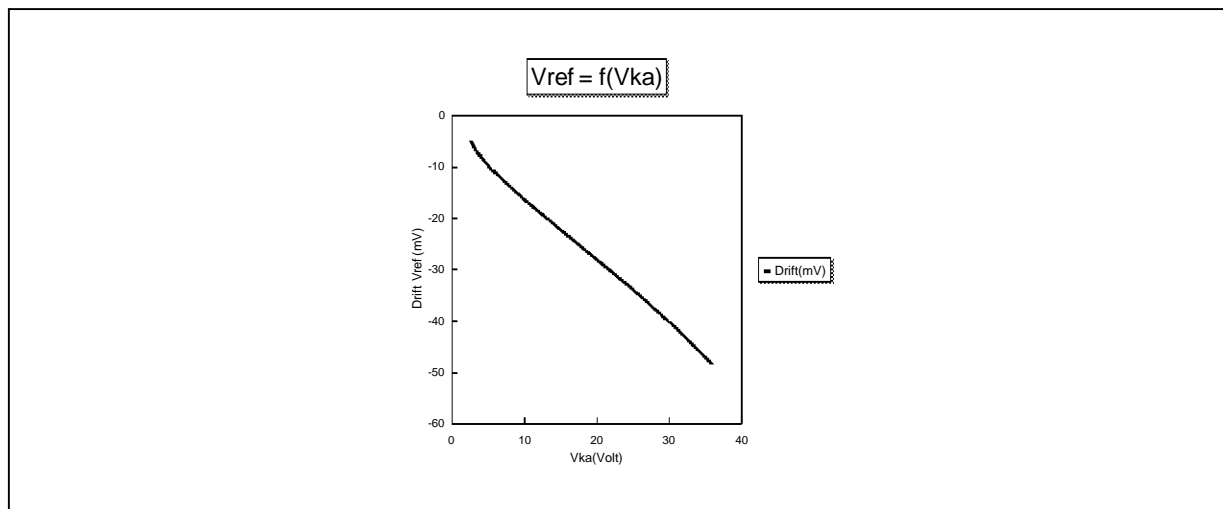

**PACKAGE MECHANICAL DATA**

8 PINS - PLASTIC DIP

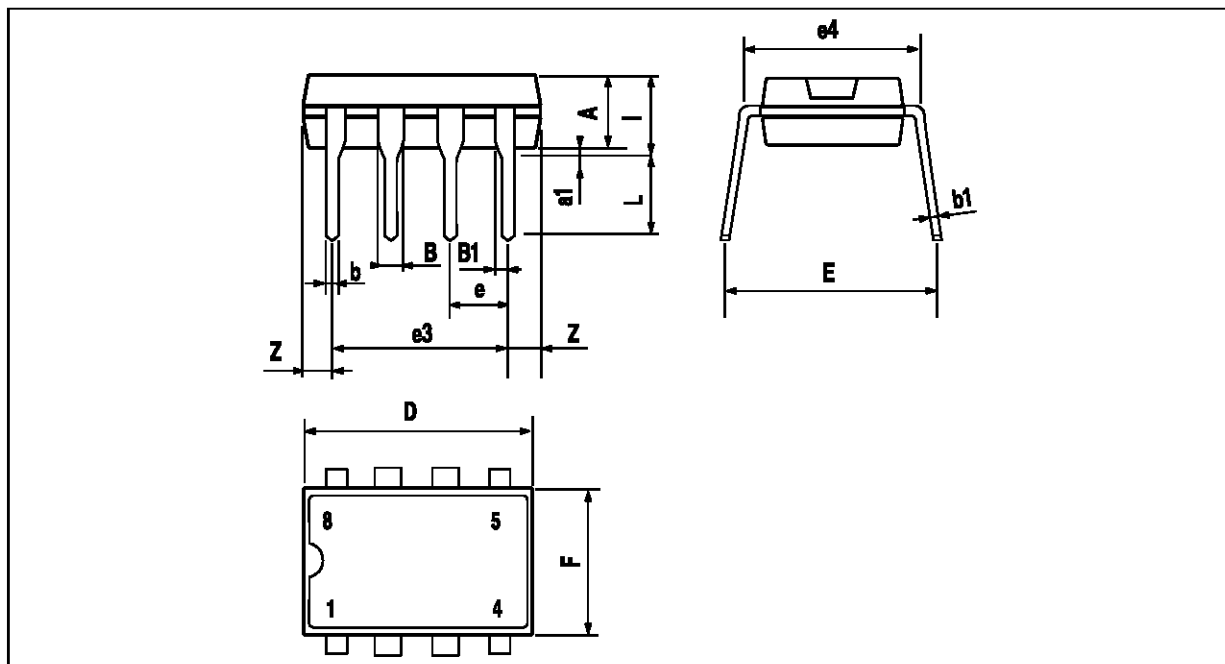

Dim.	Millimeters			Inches		
	Min.	Typ.	Max.	Min.	Typ.	Max.
A		3.32			0.131	
a1	0.51			0.020		
B	1.15		1.65	0.045		0.065
b	0.356		0.55	0.014		0.022
b1	0.204		0.304	0.008		0.012
D			10.92			0.430
E	7.95		9.75	0.313		0.384
e		2.54			0.100	
e3		7.62			0.300	
e4		7.62			0.300	
F			6.6			0.260
i			5.08			0.200
L	3.18		3.81	0.125		0.150
Z			1.52			0.060

**PACKAGE MECHANICAL DATA**  
**8 PINS - BATWING PLASTIC MICROPACKAGE (SO)**

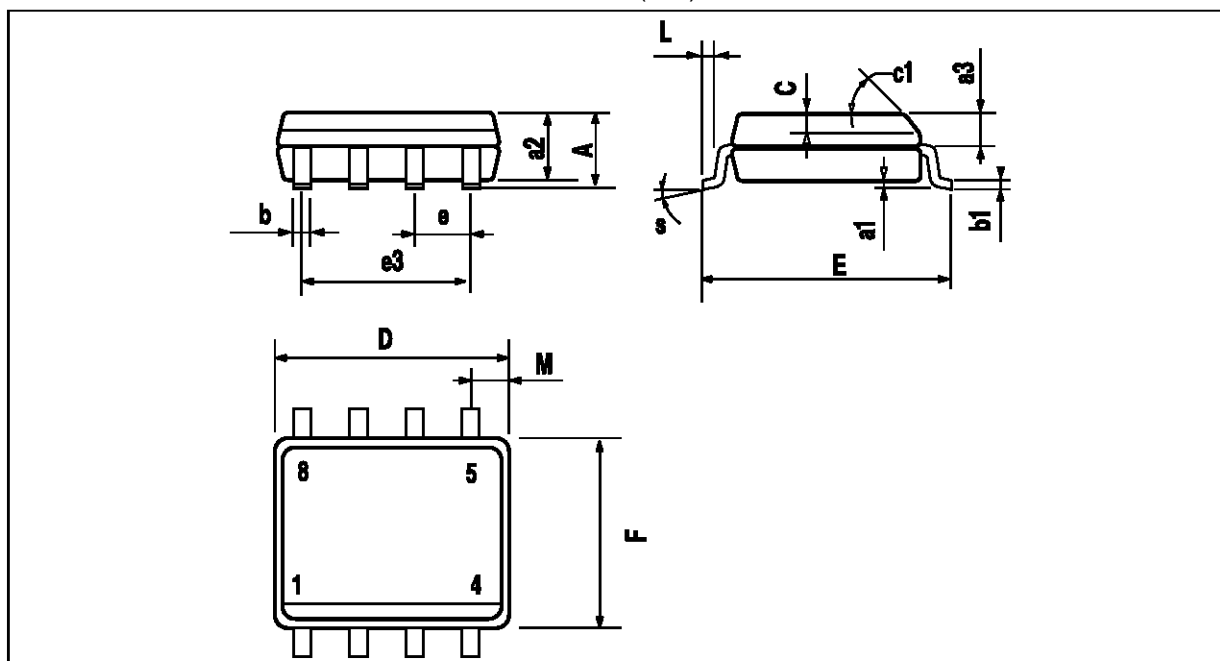

Dimensions	Millimeters			Inches		
	Min.	Typ.	Max.	Min.	Typ.	Max.
A			1.75			0.069
a1	0.1		0.25	0.004		0.010
a2			1.65			0.065
a3	0.65		0.85	0.026		0.033
b	0.35		0.48	0.014		0.019
b1	0.19		0.25	0.007		0.010
C	0.25		0.5	0.010		0.020
c1	45° (typ.)					
D	4.8		5.0	0.189		0.197
E	5.8		6.2	0.228		0.244
e		1.27			0.050	
e3		3.81			0.150	
F	3.8		4.0	0.150		0.157
L	0.4		1.27	0.016		0.050
M			0.6			0.024
S	8° (max.)					

**PACKAGE MECHANICAL DATA**  
**3 PINS - PLASTIC PACKAGE TO92**

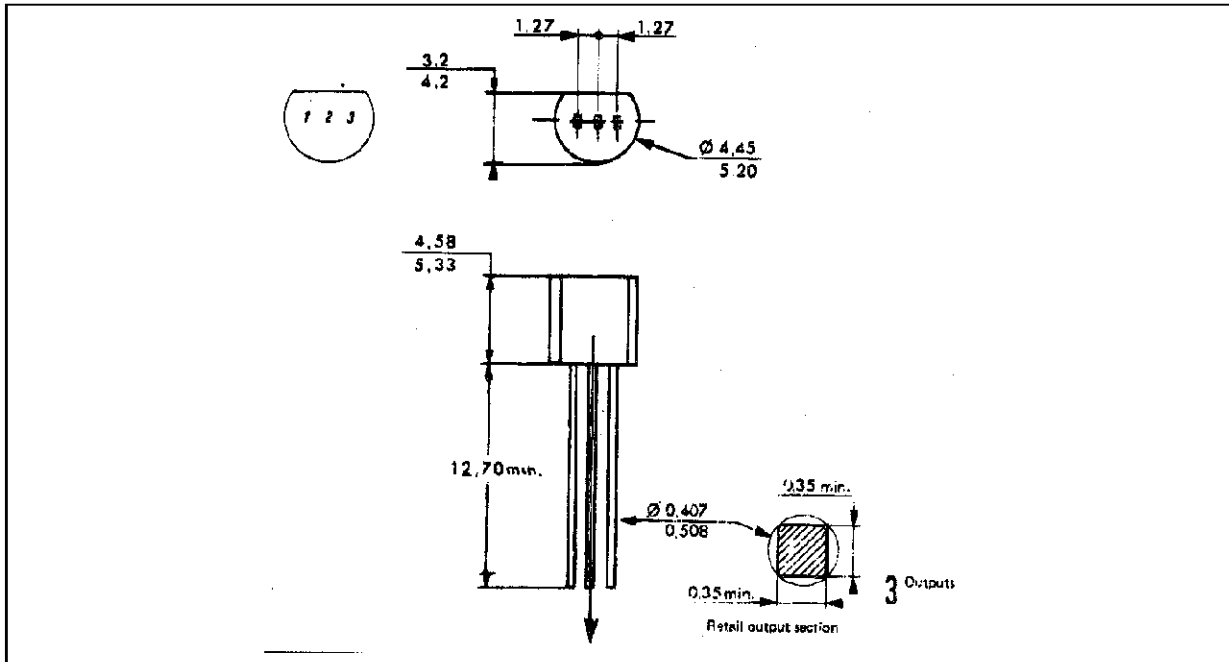

Dimensions	Millimeters			Inches		
	Min.	Typ.	Max.	Min.	Typ.	Max.
L		1.27			0.05	
B	3.2	3.7	4.2	0.126	0.1457	0.1654
O1	4.45	5.00	5.2	0.1752	0.1969	0.2047
C	4.58	5.03	5.33	0.1803	0.198	0.2098
K	12.7			0.5		
O2	0.407	0.5	0.508	0.016	0.0197	0.02
a	0.35			0.0138		

Information furnished is believed to be accurate and reliable. However, SGS-THOMSON Microelectronics assumes no responsibility for the consequences of use of such information nor for any infringement of patents or other rights of third parties which may result from its use. No license is granted by implication or otherwise under any patent or patent rights of SGS-THOMSON Microelectronics. Specifications mentioned in this publication are subject to change without notice. This publication supersedes and replaces all information previously supplied. SGS-THOMSON Microelectronics products are not authorized for use as critical components in life support devices or systems without express written approval of SGS-THOMSON Microelectronics.

© 1997 SGS-THOMSON Microelectronics – Printed in Italy – All Rights Reserved

SGS-THOMSON Microelectronics GROUP OF COMPANIES  
 Australia - Brazil - Canada - China - France - Germany - Hong Kong - Italy - Japan - Korea - Malaysia - Malta - Morocco  
 The Netherlands - Singapore - Spain - Sweden - Switzerland - Taiwan - Thailand - United Kingdom - U.S.A.