



OPA603

High Speed, Current-Feedback OPERATIONAL AMPLIFIER

FEATURES

- BANDWIDTH: 100MHz, G = 1 to 10
- SLEW RATE: 1000V/ μ s
- FAST SETTLING TIME: 50ns to 0.1%
- WIDE SUPPLY RANGE: ± 4.5 to ± 18 V
- HIGH OUTPUT CURRENT: ± 150 mA peak
- 8-PIN PLASTIC MINI-DIP PACKAGE
- SOL-16 SURFACE-MOUNT PACKAGE

APPLICATIONS

- VIDEO AMPLIFIER
- PULSE AMPLIFIER
- SONAR, ULTRASOUND CIRCUITRY
- ATE PIN DRIVERS
- LINE DRIVERS
- FAST DATA ACQUISITION
- WAVEFORM GENERATORS

DESCRIPTION

The OPA603 is a high-speed current-feedback op amp with guaranteed specifications at both ± 5 V and ± 15 V power supplies. It can deliver full ± 10 V signals into 150Ω loads with up to 1000 V/ μ s slew rate. This allows it to drive terminated 75Ω cables. With 150 mA peak output current capability it is suitable for driving load capacitance or long lines at high speed.

In contrast with conventional op amps, the current-feedback approach provides nearly constant bandwidth and settling time over a wide range of closed-loop voltage gains.

The OPA603 is available in a plastic 8-pin dual-in-line and SOL-16 surface-mount packages, specified for the industrial temperature range.

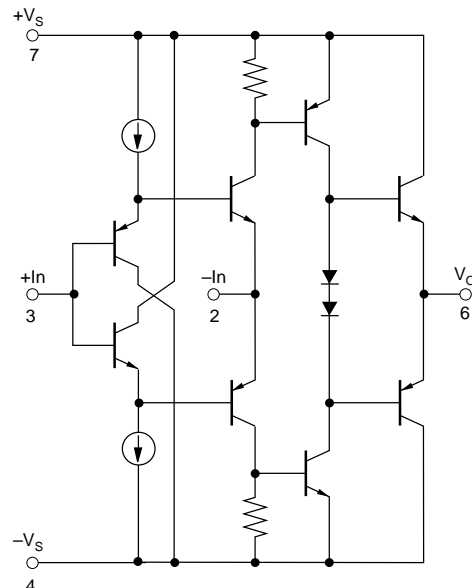

SPECIFICATIONS, $V_S = \pm 15V$

ELECTRICAL

$T_A = +25^\circ C$, $R_L = 150\Omega$ unless otherwise noted.

PARAMETER	CONDITIONS	OPA603AP/AU			UNITS
		MIN	TYP	MAX	
INPUT OFFSET VOLTAGE Initial vs Temperature vs Common-Mode Voltage vs Supply (tracking) Voltage vs Supply (non-tracking) ⁽¹⁾	$V_{CM} = \pm 10V$ $V_S = \pm 12V$ to $\pm 18V$ $ V_S = 12V$ to $18V$			5	mV $\mu V/^\circ C$ dB dB
+INPUT BIAS CURRENT Initial vs Temperature vs Common-Mode vs Supply (tracking) vs Supply (non-tracking) ⁽¹⁾	$V_{CM} = \pm 10V$ $V_S = \pm 12V$ to $\pm 18V$ $ V_S = 12V$ to $18V$			5	μA $nA/^\circ C$ nA/V nA/V nA/V
-INPUT BIAS CURRENT Initial vs Temperature vs Common-Mode vs Supply (tracking) vs Supply (non-tracking) ⁽¹⁾	$V_{CM} = \pm 10V$ $V_S = \pm 12V$ to $\pm 18V$ $ V_S = 12V$ to $18V$			25	μA $nA/^\circ C$ nA/V nA/V nA/V
INPUT IMPEDANCE +Input -Input					$M\Omega \parallel pF$ $\Omega \parallel pF$
OPEN LOOP CHARACTERISTICS Transresistance Transcapacitance	$V_O = \pm 10V$	300	440		k Ω pF
OUTPUT CHARACTERISTICS Voltage Peak Current Short-Circuit Current ⁽²⁾ Output Resistance, Open-Loop	$R_L = 150\Omega$ $V_O = 0V$	± 10	± 12 150 250 70		V mA mA Ω
FREQUENCY RESPONSE Small-Signal Bandwidth ⁽³⁾ Gain Flatness, $\pm 0.5dB$ Full-Power Bandwidth Differential Gain Differential Phase	$G = +2$ $V_O = 20Vp-p$ $f = 4.43MHz$, $V_O = 1V$ $f = 4.43MHz$, $V_O = 1V$	70 35	160 75 10 0.03 0.025		MHz MHz MHz % Degrees
TIME DOMAIN RESPONSE Propagation Delay Rise and Fall Time Settling Time to 0.10% Slew Rate	$G = +2$ 10V Step		10 10 50 1000		ns ns ns V/ μs
DISTORTION 2nd Harmonic Distortion 3rd Harmonic Distortion	$G = +2$, $R_L = 100\Omega$, $f = 10MHz$ $V_O = 0.2Vp-p$ $V_O = 0.2Vp-p$	-60 -70	-65 -90		dBc dBc
POWER SUPPLY Specified Operating Voltage Operating Voltage Range Current		± 4.5	± 15 ± 21	± 18 ± 25	V V mA
TEMPERATURE RANGE Specification Storage		-25 -40		+85 +150	$^\circ C$ $^\circ C$
THERMAL RESISTANCE, $\theta_{JUNCTION-AMBIENT}$	Soldered to Printed Circuit		90		$^\circ C/W$

NOTES: (1) One power supply fixed at 15V; the other supply varied from 12V to 18V. (2) Observe power derating curve. (3) See bandwidth versus gain curve, Figure 5.

The information provided herein is believed to be reliable; however, BURR-BROWN assumes no responsibility for inaccuracies or omissions. BURR-BROWN assumes no responsibility for the use of this information, and all use of such information shall be entirely at the user's own risk. Prices and specifications are subject to change without notice. No patent rights or licenses to any of the circuits described herein are implied or granted to any third party. BURR-BROWN does not authorize or warrant any BURR-BROWN product for use in life support devices and/or systems.

SPECIFICATIONS, $V_S = \pm 5V$

ELECTRICAL

$T_A = +25^\circ\text{C}$, $R_L = 75\Omega$ unless otherwise noted.

PARAMETER	CONDITIONS	OPA603AP/AU			UNITS
		MIN	TYP	MAX	
INPUT OFFSET VOLTAGE Initial vs Temperature vs Common-Mode vs Supply (tracking) vs Supply (non-tracking) ⁽¹⁾	$V_{CM} = \pm 3V$ $V_S = \pm 4V$ to $\pm 6V$ $ V_S = 4V$ to $6V$			6	mV
		50	8		$\mu\text{V}/^\circ\text{C}$
		75	55		dB
		55	80		dB
+INPUT BIAS CURRENT Initial vs Temperature vs Common-Mode vs Supply (tracking) vs Supply (non-tracking) ⁽¹⁾	$V_{CM} = \pm 3V$ $V_S = \pm 4V$ to $\pm 6V$ $ V_S = 4V$ to $6V$			5	μA
			30		$\text{nA}/^\circ\text{C}$
			350	600	nA/V
			100	200	nA/V
-INPUT BIAS CURRENT Initial vs Temperature vs Common-Mode vs Supply (tracking) vs Supply (non-tracking) ⁽¹⁾	$V_{CM} = \pm 3V$ $V_S = \pm 4V$ to $\pm 6V$ $ V_S = 4V$ to $6V$			25	μA
			300		$\text{nA}/^\circ\text{C}$
			300	600	nA/V
			500	700	nA/V
INPUT IMPEDANCE +Input -Input			3.3 2		$\text{M}\Omega$ pF
			30 2		Ω pF
OPEN LOOP CHARACTERISTICS Transresistance Transcapacitance	$V_O = \pm 2V$	225	330		k Ω
			2.4		pF
OUTPUT CHARACTERISTICS Voltage Peak Current Short-Circuit Current ⁽²⁾ Output Resistance, Open-Loop	$R_L = 75\Omega$ $V_O = 0V$	± 2	± 2.75		V
			150		mA
			250		mA
			80		Ω
FREQUENCY RESPONSE Small-Signal Bandwidth ⁽³⁾ Gain Flatness, $\pm 0.5\text{dB}$ Full-Power Bandwidth Differential Gain Differential Phase	$G = +2$ $f = 4.43\text{MHz}$, $V_O = 1V$, $R_L = 150\Omega$ $f = 4.43\text{MHz}$, $V_O = 1V$, $R_L = 150\Omega$		140		MHz
			65		MHz
			20		MHz
			0.03		%
			0.025		Degrees
TIME DOMAIN RESPONSE Propagation Delay Rise and Fall Time Settling Time to 0.10% Slew Rate	$G = +2$, $R_L = 100\Omega$		15		ns
			20		ns
			60		ns
			750		V/ μs
DISTORTION 2nd Harmonic Distortion 3rd Harmonic Distortion	$G = +2$, $R_L = 100\Omega$, $f = 10\text{MHz}$ $V_O = 0.2V_{p-p}$ $V_O = 0.2V_{p-p}$		-67		dBc
			-78		dBc
POWER SUPPLY Specified Operating Voltage Operating Voltage Range Current		± 4.5	± 5	± 18	V
			± 21	± 25	V
					mA
TEMPERATURE RANGE Specification Storage		-25		+85	$^\circ\text{C}$
		-40		+150	$^\circ\text{C}$
THERMAL RESISTANCE , $\theta_{\text{JUNCTION-AMBIENT}}$	Soldered to Printed Circuit		90		$^\circ\text{C}/\text{W}$

NOTES: (1) One power supply fixed at 5V; the other supply varied from 4V to 6V. (2) Observe power derating curve. (3) See bandwidth versus gain curves, Figure 5.

PIN CONFIGURATION

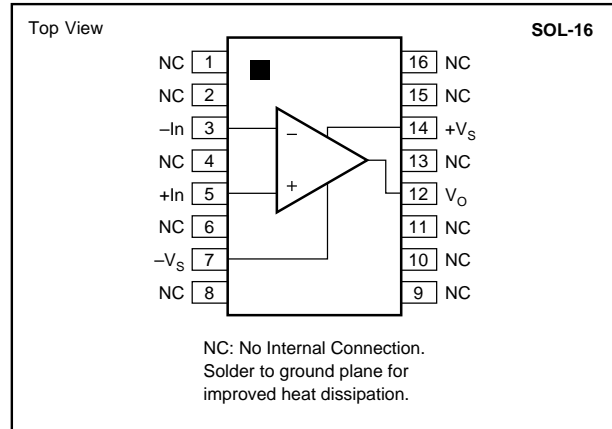
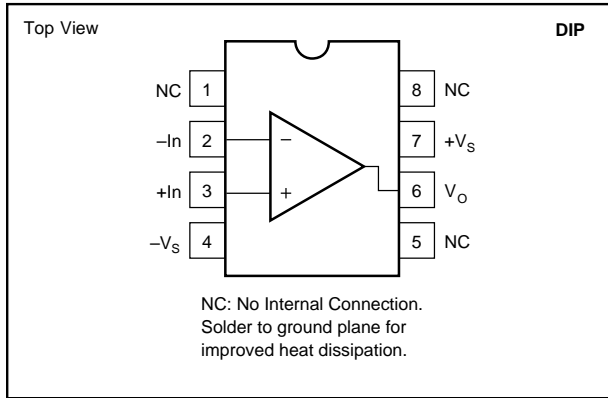

ABSOLUTE MAXIMUM RATINGS

Supply Voltage	±18V
Input Voltage Range	±Vs
Differential Input Voltage	±6V
Power Dissipation	See derating curve
Operating Temperature	+100°C
Storage Temperature	+150°C
Junction Temperature	+150°C
Lead Temperature (soldering, 10s)	+300°C
Lead Temperature (soldering SOL-16 package, 3s)	+260°C

ORDERING INFORMATION

MODEL	PACKAGE	SPECIFIED TEMPERATURE RANGE
OPA603AP	Plastic DIP	-25°C to +85°C
OPA603AU	SOL-16	-25°C to +85°C

PACKAGE INFORMATION

MODEL	PACKAGE	PACKAGE DRAWING NUMBER ⁽¹⁾
OPA603AP	Plastic DIP	006
OPA603AU	SOL-16	211

NOTE: (1) For detailed drawing and dimension table, please see end of data sheet, or Appendix D of Burr-Brown IC Data Book.

DICE INFORMATION

OPA603 DIE TOPOGRAPHY

PAD	FUNCTION
1	Noninverting Input
2	-Vs
3	Laser Alignment
4	Vo (Output)
5	+Vs
6	RT (Trim Sense Point)
7	CE (Compensation Capacitor)
8	Inverting Input

Substrate Bias: Dielectrically Isolated.
Recommend tying to +Vs.

MECHANICAL INFORMATION

	MILS (0.001")	MILLIMETERS
Die Size	94 x 69 ±5	2.39 x 1.75 ±0.13
Die Thickness	20 ±3	0.51 ±0.08
Min. Pad Size	4 x 4	0.10 x 0.10
Backing	Gold	

TYPICAL PERFORMANCE CURVES

$T_A = +25^\circ\text{C}$ unless otherwise noted.

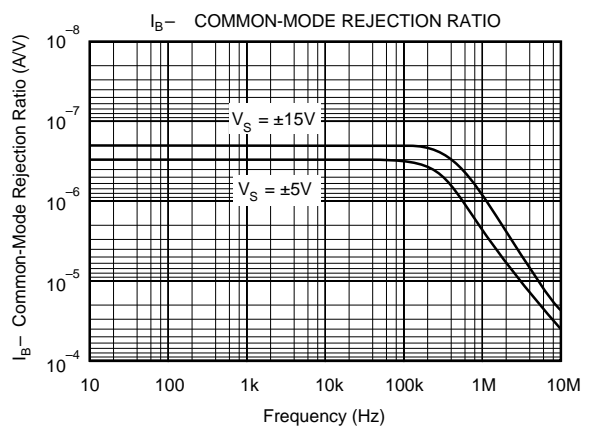
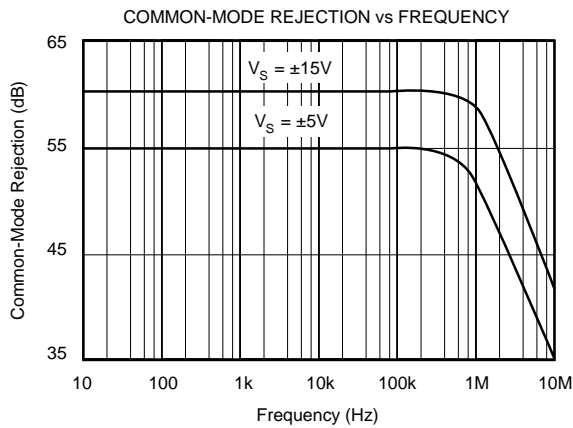
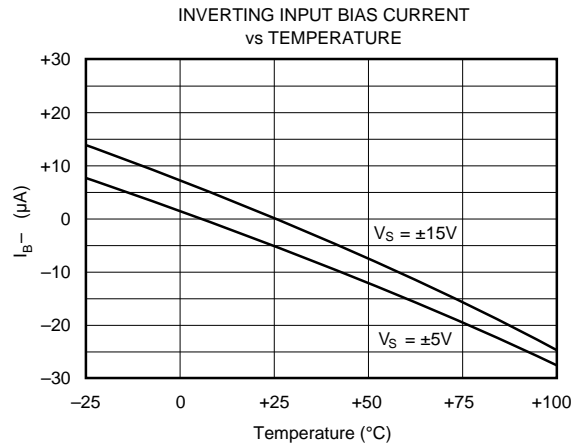
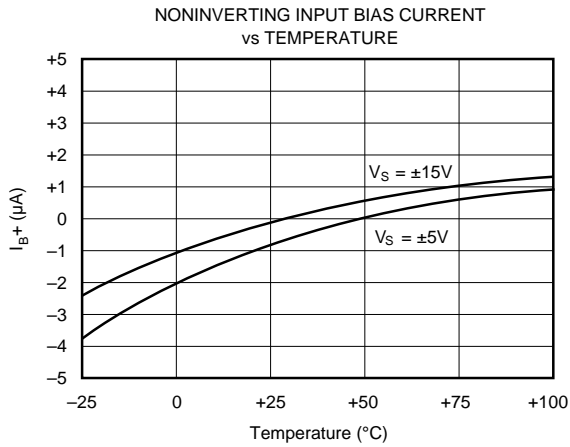
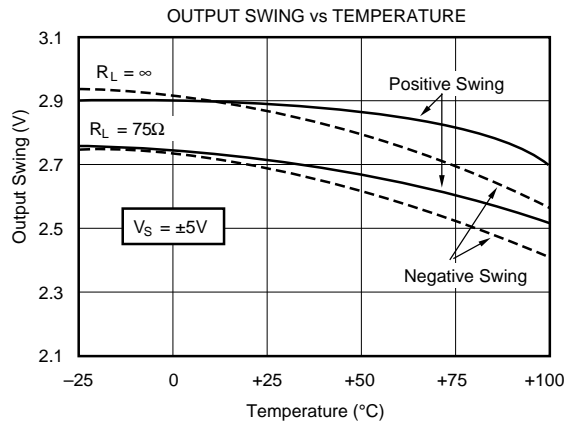
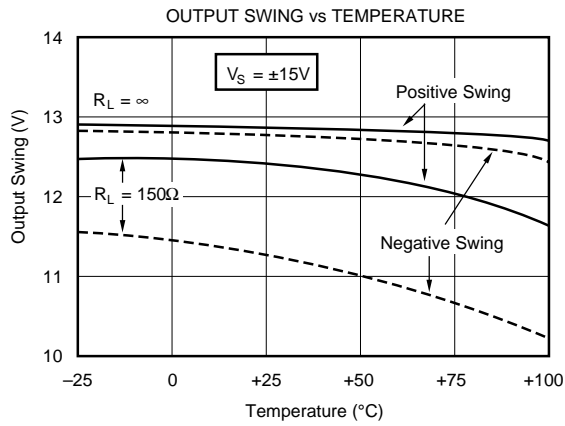

TYPICAL PERFORMANCE CURVES (CONT)

$T_A = +25^\circ\text{C}$ unless otherwise noted.

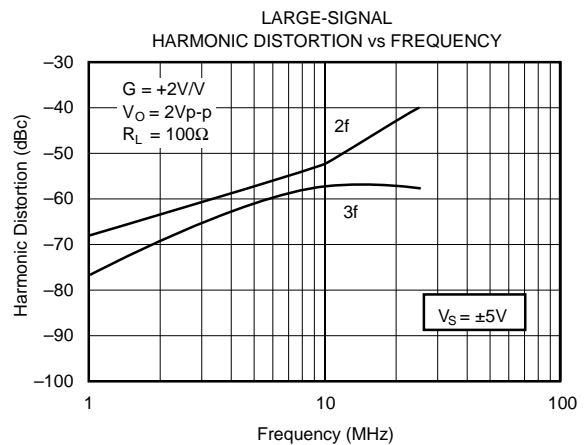
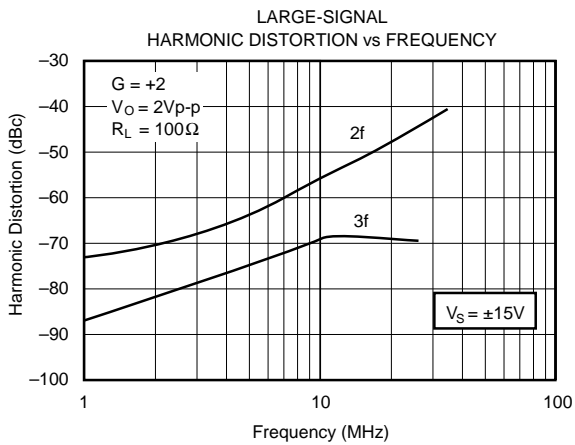
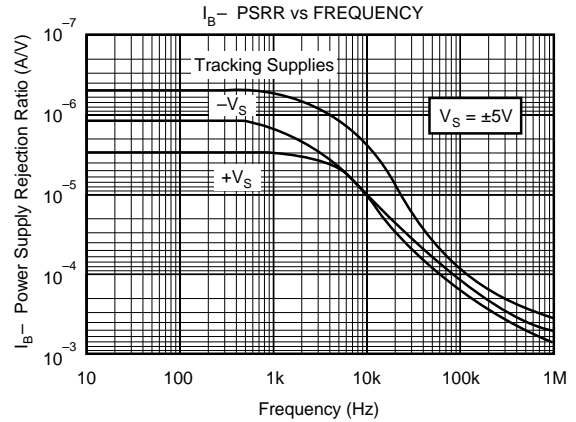
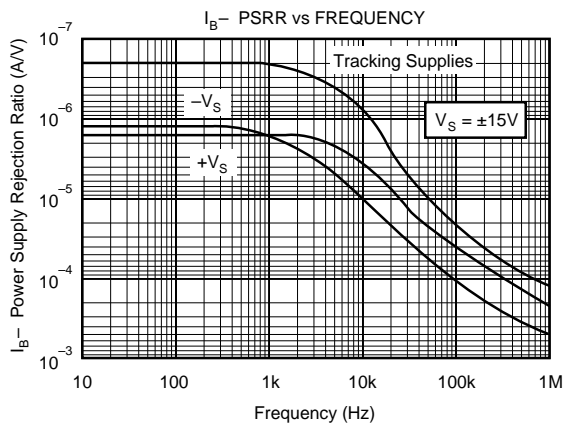
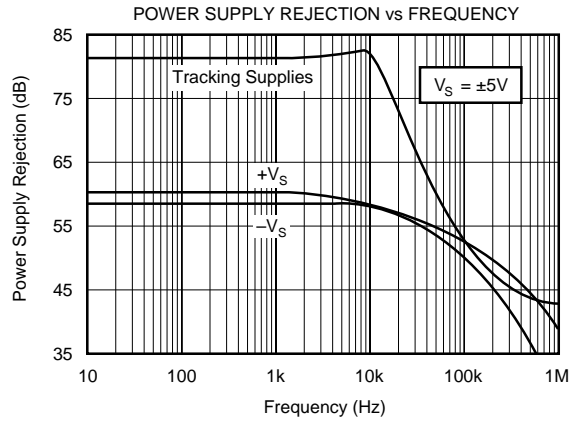
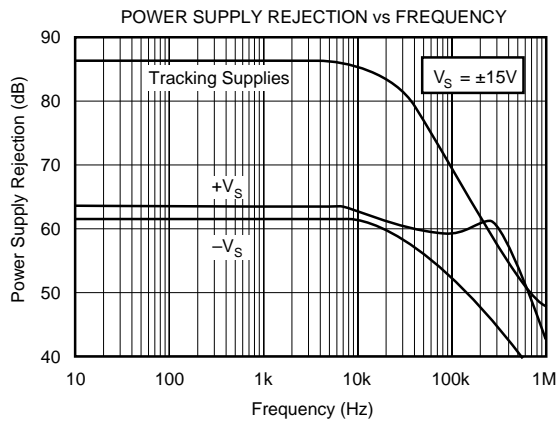

TYPICAL PERFORMANCE CURVES (CONT)

T_A = +25°C unless otherwise noted.

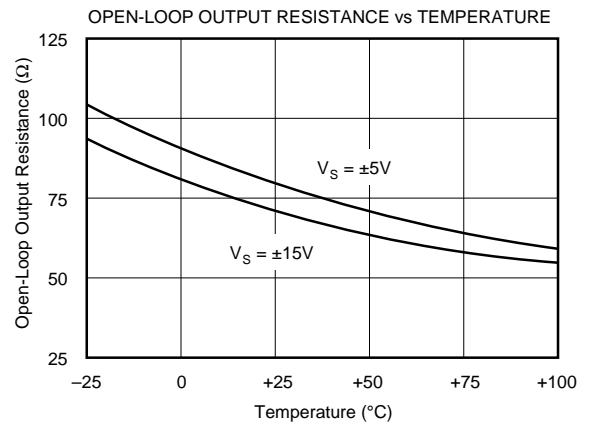
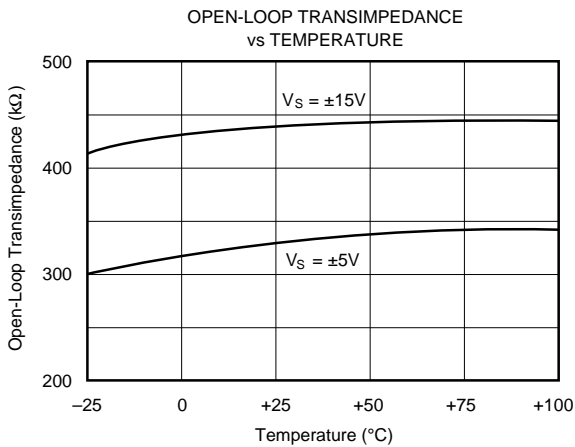
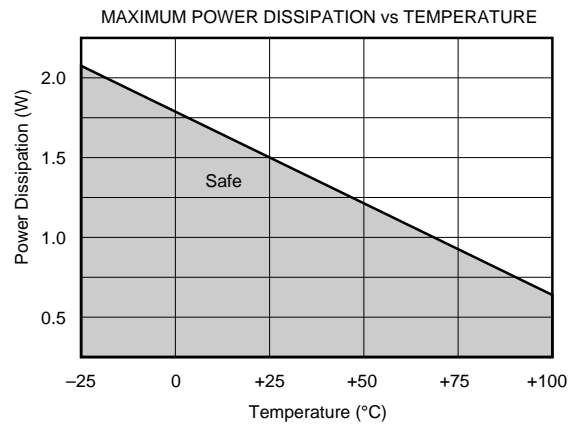
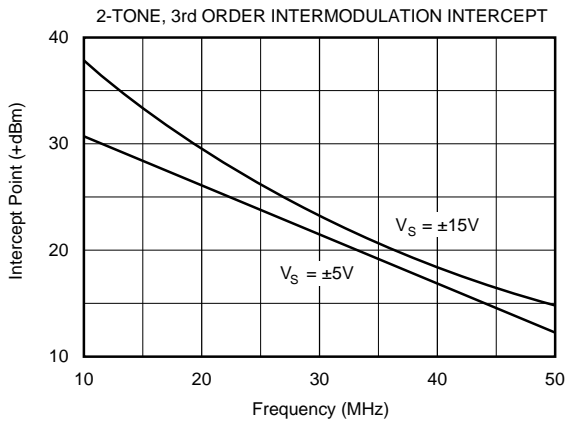
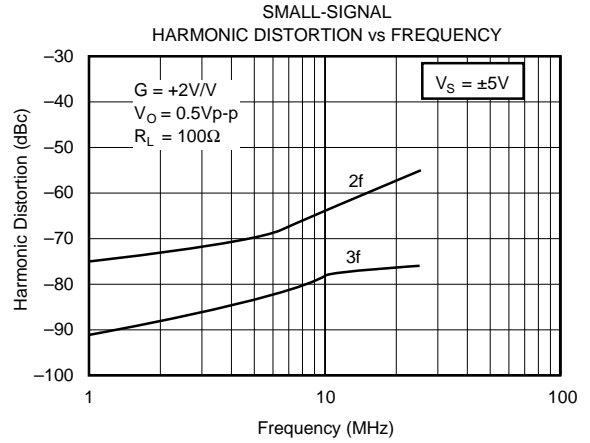
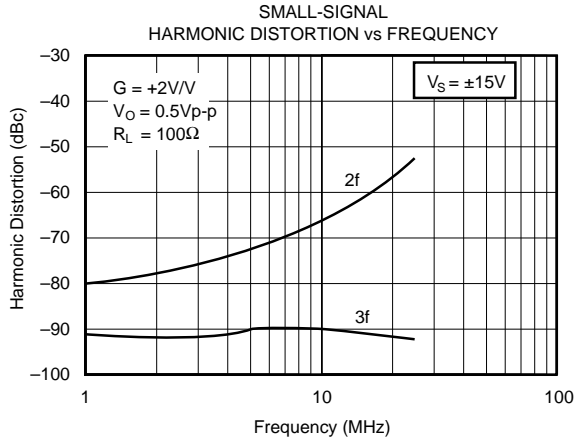

TYPICAL PERFORMANCE CURVES (CONT)

$T_A = +25^\circ\text{C}$ unless otherwise noted.

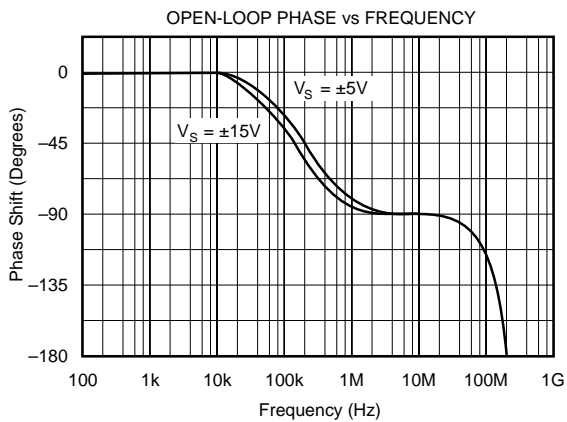
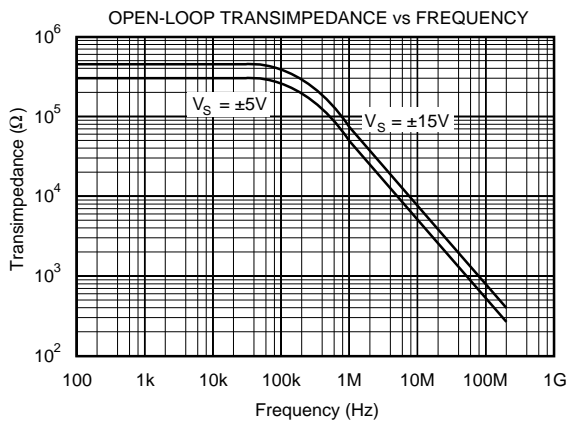
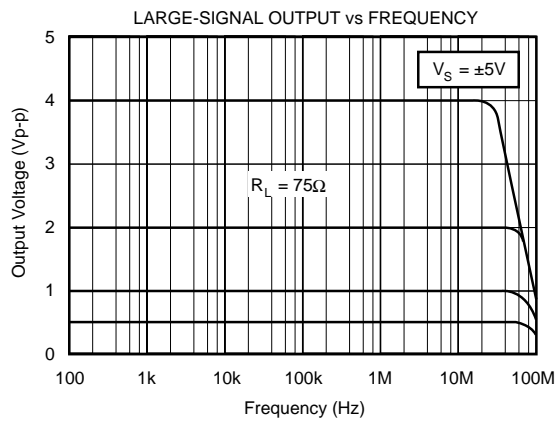
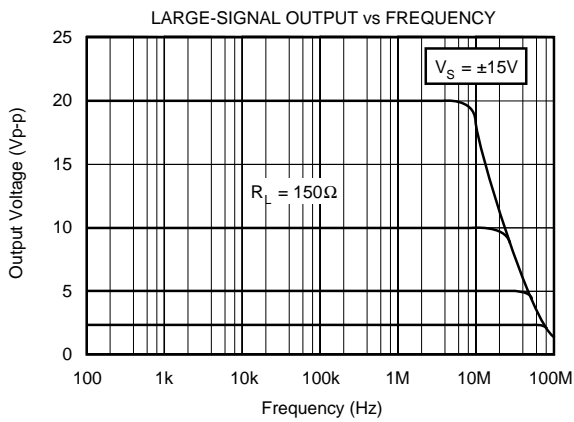
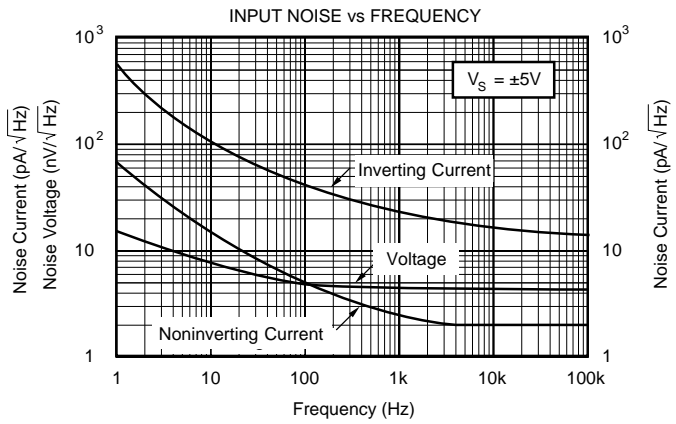
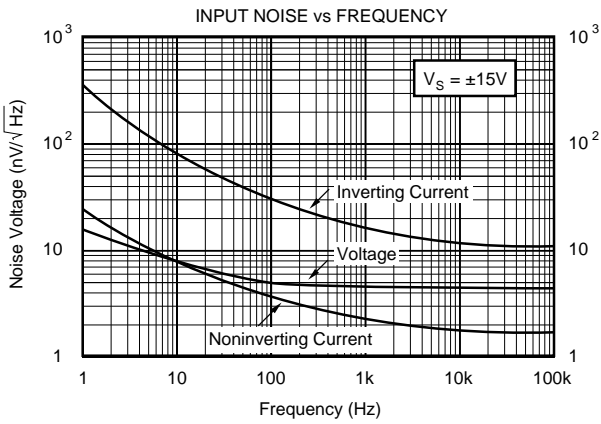

TYPICAL PERFORMANCE CURVES (CONT)

$T_A = +25^\circ\text{C}$ unless otherwise noted.

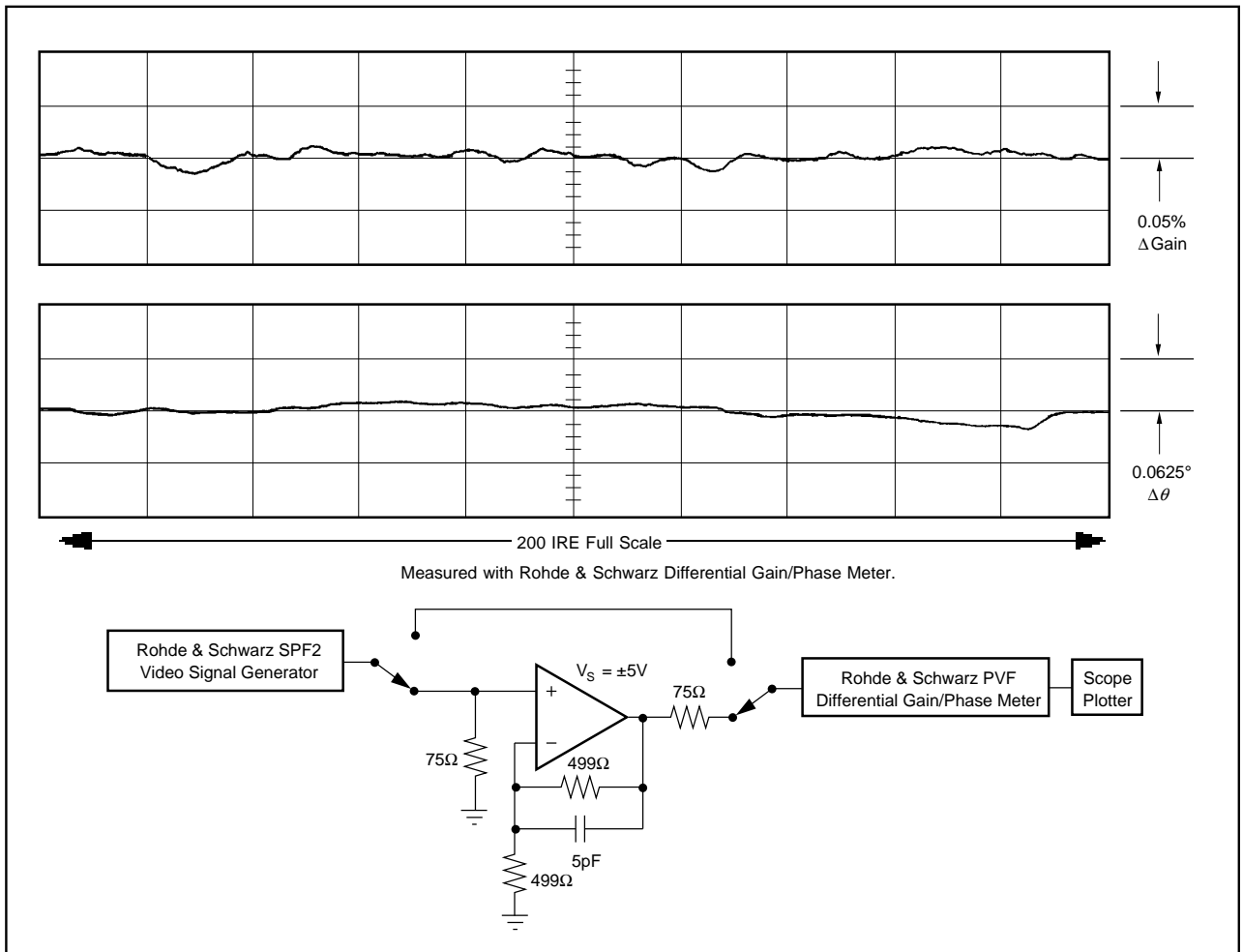
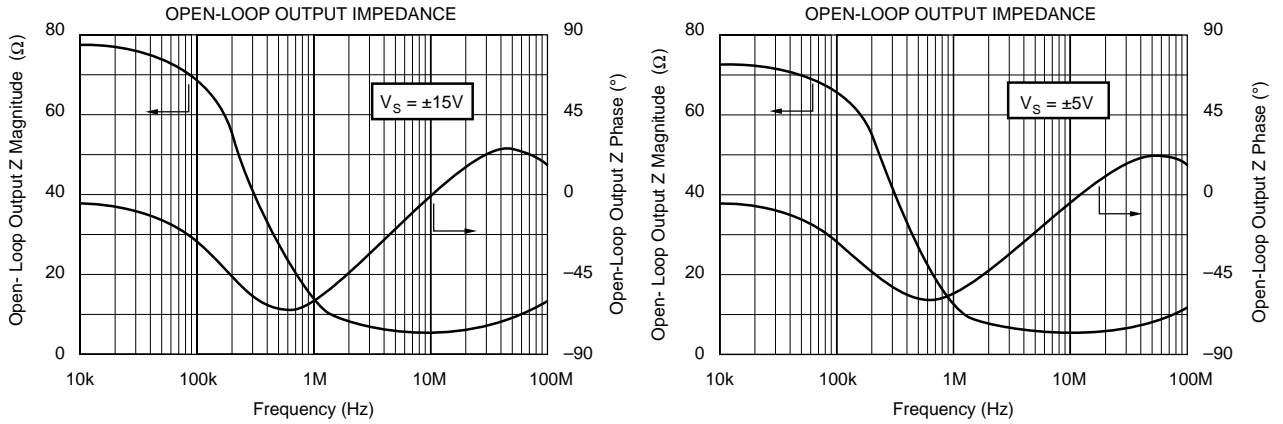

FIGURE 1. Video Differential Gain/Phase Performance.

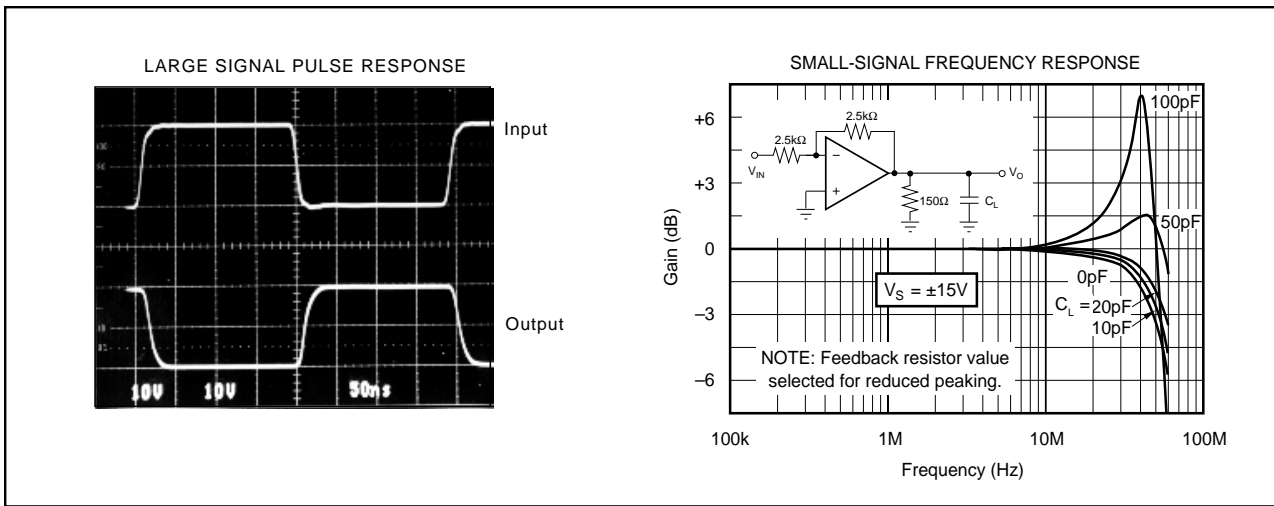

FIGURE 2. Dynamic Response, Inverting Unity-Gain.

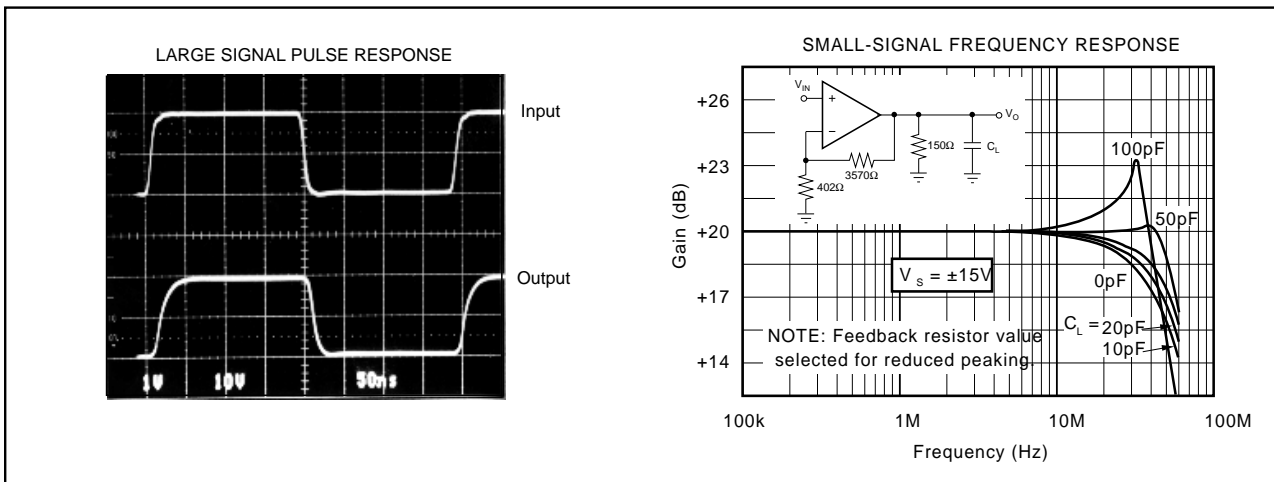

FIGURE 3. Dynamic Response, Gain = +10.

APPLICATIONS INFORMATION

For most circuit configurations, the OPA603 current-feedback op amp can be treated like a conventional op amp. As with a conventional op amp, the feedback network connected to the inverting input controls the closed-loop gain. But with a current-feedback op amp, the impedance of the feedback network also controls the open-loop gain and frequency response.

Feedback resistor values can be selected to provide a nearly constant closed-loop bandwidth over a very wide range of gain. This is in contrast to a conventional op amp where circuit bandwidth is inversely proportional to the closed-loop gain, sharply limiting bandwidth at high gain.

Figures 4a and 4b show appropriate feedback resistor values versus closed-loop gain for maximum bandwidth with minimal peaking. The dual vertical axes of these curves also show the resulting bandwidth. Note that the bandwidth remains nearly constant as gain is increased.

With control of the open-loop characteristics of the op amp, dynamic behavior can be tailored to an application's requirements. Lower feedback resistance gives wider bandwidth, more frequency-response peaking and more pulse response overshoot. The higher open-loop gain resulting from lower feedback network resistors also yields lower distortion. Higher feedback network resistance gives an over-damped response with little or no peaking and overshoot. This may be beneficial when driving capacitive loads. Feedback network impedance can also be varied to optimize dynamic performance. To achieve wider bandwidth, use a feedback resistor value somewhat lower than indicated in Figure 4.

EXTENDING BANDWIDTH

For gains less than approximately 20, bandwidth can be extended by adding a capacitor, C_F, in parallel with a lower value for R_F. The optimum gain-setting resistor value in this case is far lower than those shown in Figure 1. For ±15V operation, select R_F with the following equation:

$$R_F (\Omega) = 30 \cdot (30 - G) \quad \text{for } V_s = \pm 15V$$

For example, for a gain of 10, use $R_F = 600\Omega$. Optimum values differ slightly for $\pm 5V$ operation:

$$R_F (\Omega) = 30 \cdot (23 - G) \quad \text{for } V_s = \pm 5V$$

C_F will range from 1pF to 10pF depending on the selected gain, load, and circuit layout. Adjust C_F to optimize bandwidth and minimize peaking. Figure 5 shows bandwidth which can be achieved using this technique.

Typical values for this capacitor range from 1pF to 10pF depending on closed-loop gain and load characteristics. Too large a value of C_F can cause instability.

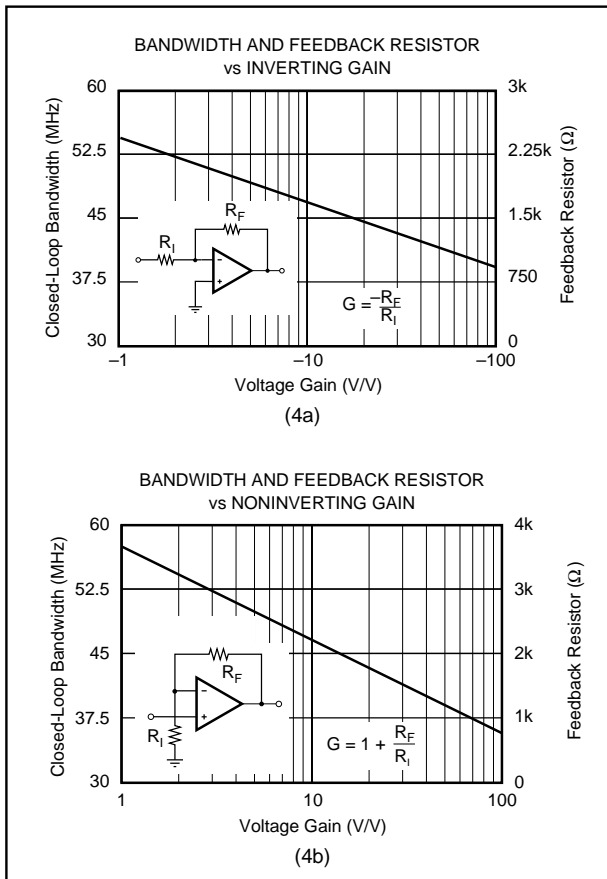

FIGURE 4. Feedback Resistor Selection Curves.

UNITY-GAIN OPERATION

As Figure 4b indicates, the OPA603 can be operated in unity gain. A feedback resistor (approximately 2.8k Ω) sets the appropriate open-loop characteristics and resistor R_I is omitted. Just as with gains greater than one, the value of the feedback resistor (and capacitor if used) can be optimized for the desired dynamic response and load characteristics.

Care should be exercised not to exceed the maximum differential input voltage rating of $\pm 6V$. Large input voltage steps which exceed the device's slew rate of 1000V/ μ s can apply excessive differential input voltage.

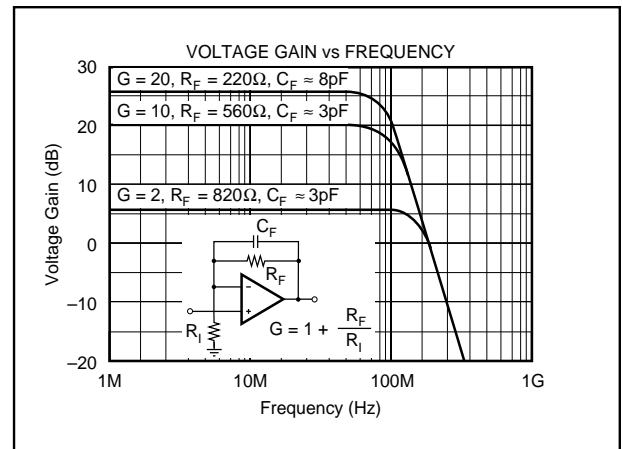

FIGURE 5. Bandwidth Results with Added Capacitor C_F .

CIRCUIT LAYOUT

With any high-speed, wide-bandwidth circuitry, careful circuit layout will ensure best performance. Make short, direct circuit interconnections and avoid stray wiring capacitance—especially at the inverting input pin. A component-side ground plane will help ensure low ground impedance. Do not place the ground plane under or near the inputs and feedback network.

Power supplies should be bypassed with good high-frequency capacitors positioned close to the op amp pins. In most cases, a 0.01 μ F ceramic capacitor in parallel with a 2.2 μ F solid tantalum capacitor at each power supply pin is adequate. The OPA603 can deliver high load current—up to 150mA peak. Applications with low impedance or capacitive loads demand large current transients from the power supplies. It is the power supply bypass capacitors which must supply these current transients. Larger bypass capacitors such as 10 μ F solid tantalum capacitors may improve performance in these applications.

POWER DISSIPATION

High output current causes increased internal power dissipation in the OPA603. Copper leadframe construction maximizes heat dissipation compared to conventional plastic packages. To achieve best heat dissipation, solder the device directly to the circuit board and use wide circuit board traces. Solder the unused pins, (1, 5 and 8) to a top-side ground plane for improved power dissipation. Limit the load and signal conditions depending on maximum ambient temperature to assure operation within the power derating curve.

The OPA603 may be operated at reduced power supply voltage to minimize power dissipation. Detailed specifications are provided for both $\pm 15V$ and $\pm 5V$ operation.

APPLICATIONS CIRCUITS

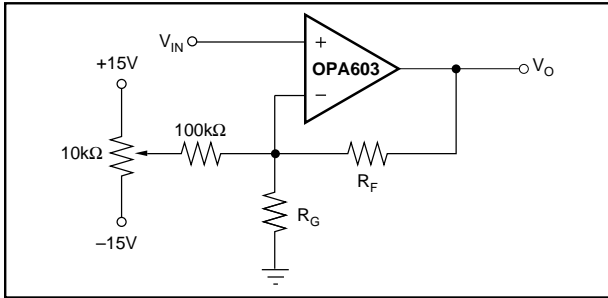

FIGURE 6. Offset Voltage Adjustment.

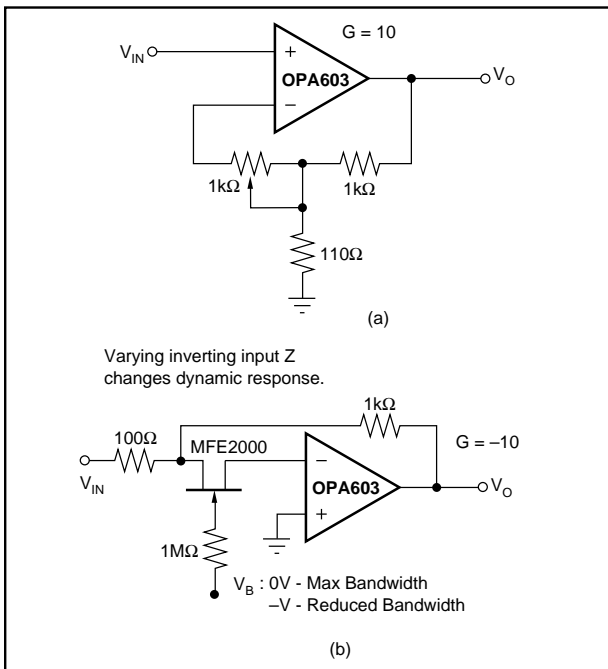

FIGURE 7. Controlling Dynamic Performance.

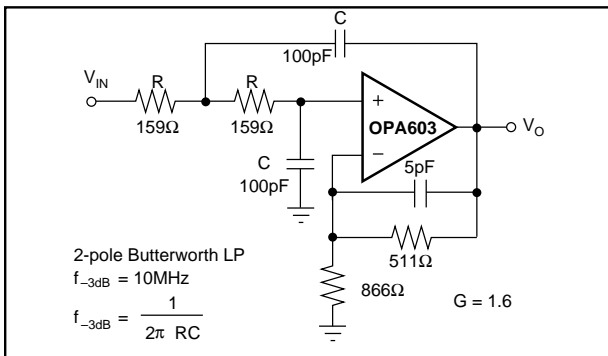

FIGURE 8. Low-Pass Filter — 10MHz.

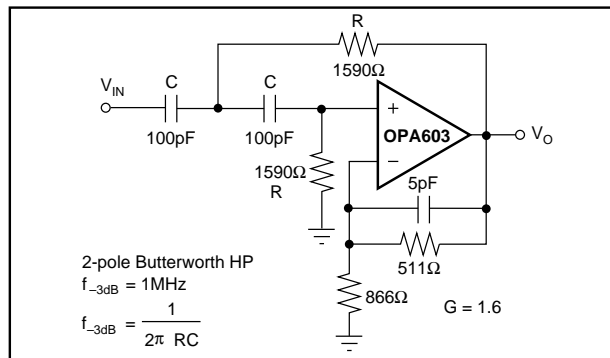

FIGURE 9. High-Pass Filter — 1MHz.

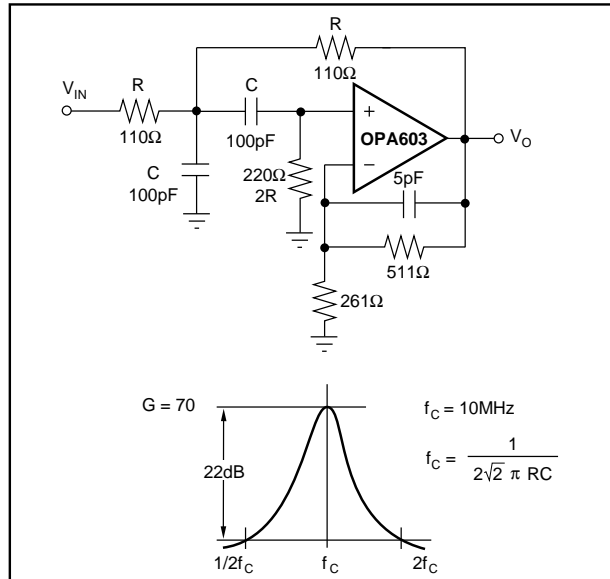
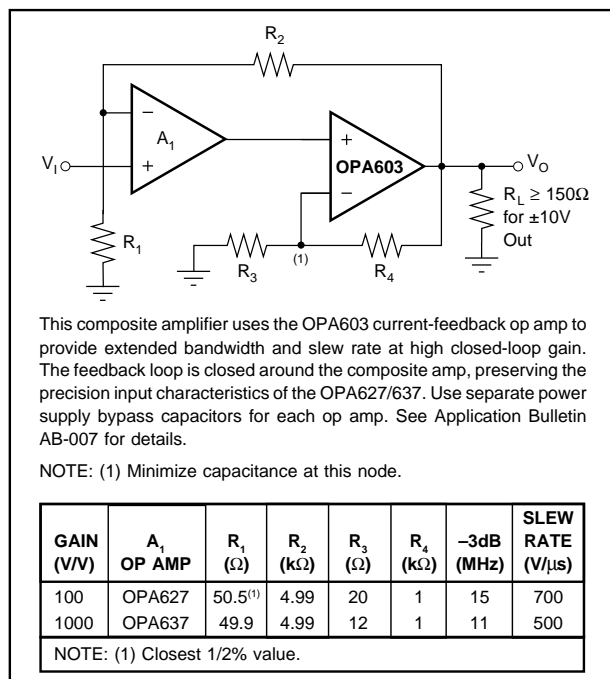

FIGURE 10. Bandpass Filter — 10MHz.



This composite amplifier uses the OPA603 current-feedback op amp to provide extended bandwidth and slew rate at high closed-loop gain. The feedback loop is closed around the composite amp, preserving the precision input characteristics of the OPA627/637. Use separate power supply bypass capacitors for each op amp. See Application Bulletin AB-007 for details.

NOTE: (1) Minimize capacitance at this node.

GAIN (V/V)	A ₁ OP AMP	R ₁ (Ω)	R ₂ (kΩ)	R ₃ (Ω)	R ₄ (kΩ)	-3dB (MHz)	SLEW RATE (V/μs)
100	OPA627	50.5 ⁽¹⁾	4.99	20	1	15	700
1000	OPA637	49.9	4.99	12	1	11	500

NOTE: (1) Closest 1/2% value.

FIGURE 11. Precision-Input Composite Amplifier.