

## LOW POWER QUAD VOLTAGE COMPARATORS

- WIDE SINGLE SUPPLY VOLTAGE RANGE OR DUAL SUPPLIES FOR ALL DEVICES : +2V TO +36V OR  $\pm 1V$  TO  $\pm 18V$
- VERY LOW SUPPLY CURRENT (1.1mA) INDEPENDENT OF SUPPLY VOLTAGE (1.4mW/comparator at +5V)
- LOW INPUT BIAS CURRENT : 25nA TYP
- LOW INPUT OFFSET CURRENT :  $\pm 5nA$  TYP
- LOW INPUT OFFSET VOLTAGE :  $\pm 1mV$  TYP
- INPUT COMMON-MODE VOLTAGE RANGE INCLUDES GROUND
- LOW OUTPUT SATURATION VOLTAGE : 250mV TYP. ( $I_o = 4mA$ )
- DIFFERENTIAL INPUT VOLTAGE RANGE EQUAL TO THE SUPPLY VOLTAGE
- TTL, DTL, ECL, MOS, CMOS COMPATIBLE OUTPUTS

### DESCRIPTION

These devices consist of four independent precision voltage comparators with an offset voltage specifications as low as 2mV max for LM339A, LM239A and LM139A. All these comparators were designed specifically to operate from a single power supply over a wide range of voltages. Operation from split power supplies is also possible.

These comparators also have a unique characteristic in that the input common-mode voltage range includes ground even though operated from a single power supply voltage.

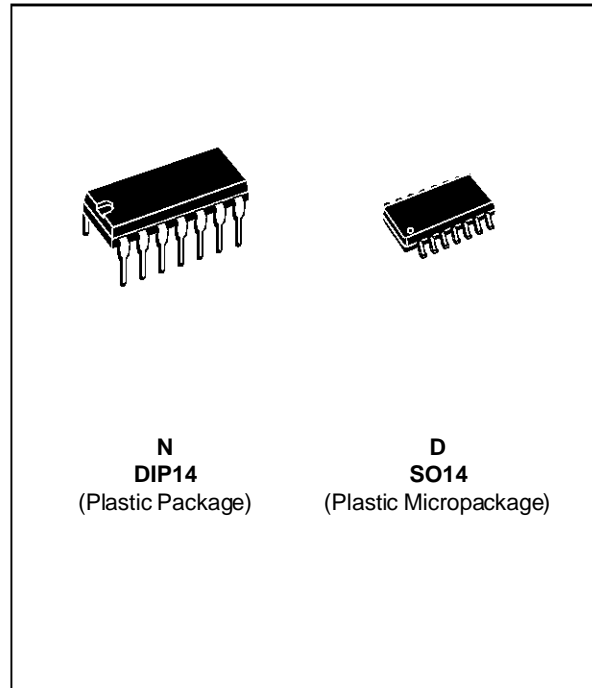

### ORDER CODES

Part Number	Temperature Range	Package	
		N	D
LM139,A	-55, +125°C	•	•
LM239,A	-40, +105°C	•	•
LM339,A	0, +70°C	•	•

**Example :** LM139AN

### PIN CONNECTIONS (top view)

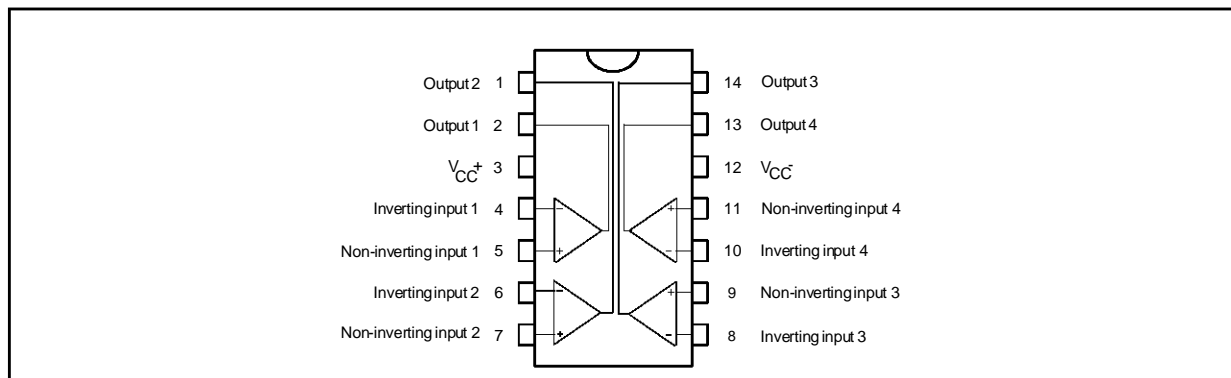

**SCHEMATIC DIAGRAM (1/4 LM139)**

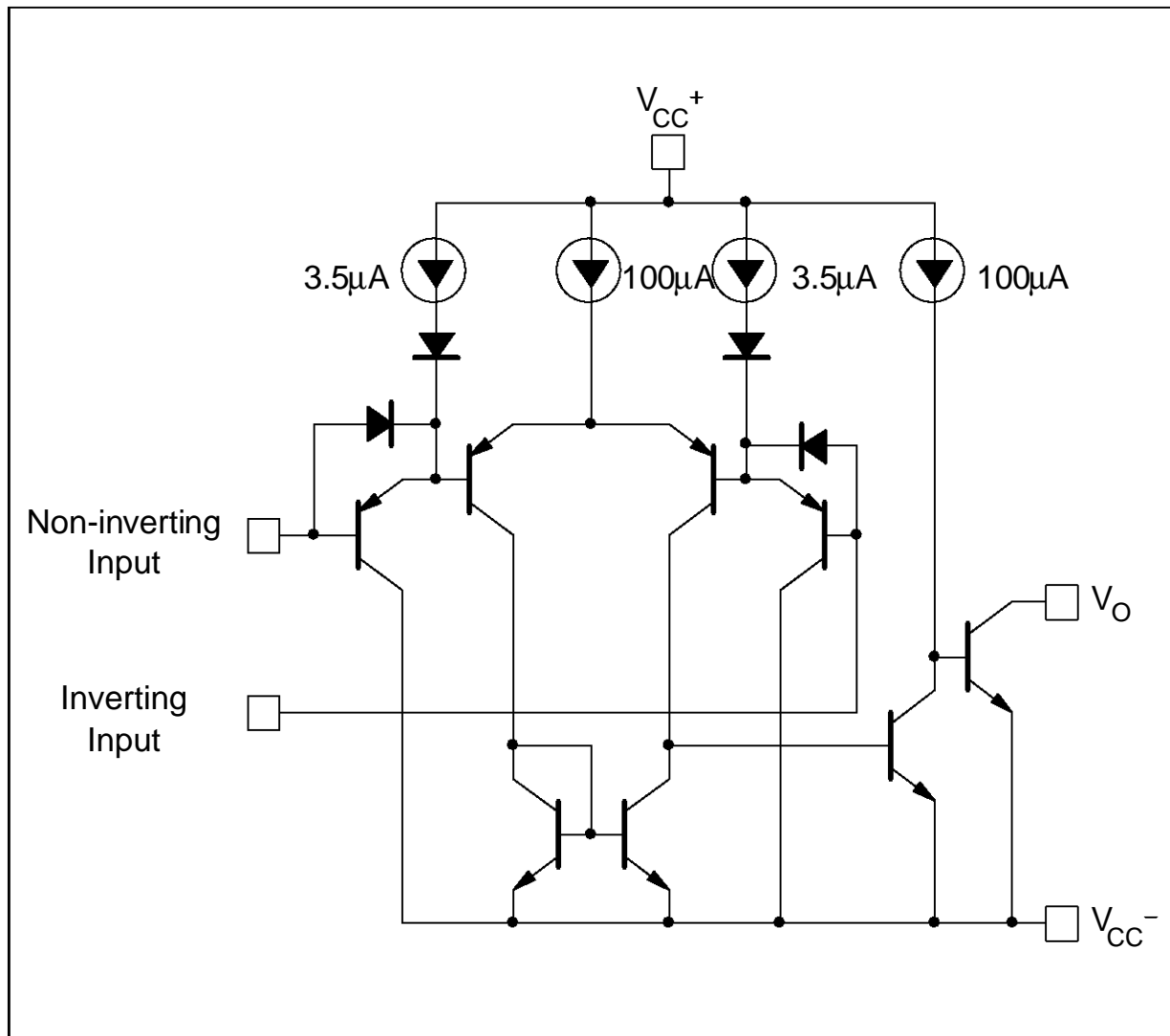

**ABSOLUTE MAXIMUM RATINGS**

Symbol	Parameter	LM139,A LM239,A	LM339,A	Unit
$V_{CC}$	Supply Voltage	$\pm 18$ to 36	$\pm 18$ to 36	V
$V_{id}$	Differential Input Voltage	$\pm 36$	$\pm 36$	V
$V_i$	Input Voltage	-0.3 to +36	-0.3 to +36	V
	Output Short-circuit to Ground - (note 1)	Infinite		
$P_{tot}$	Power Dissipation	570	570	mW
$T_{oper}$	Operating Free-air Temperature Range LM239,A	-55, +125 -40, +105	0, +70	°C
$T_{stg}$	Storage Temperature Range	-65, +150	-65, +150	°C

**Notes :** 1. Short-circuit from the output to  $V_{CC}^+$  can cause excessive heating and eventual destruction. The maximum output current is approximately 20mA, independent of the magnitude of  $V_{CC}^+$ .

**ELECTRICAL CHARACTERISTICS**

$V_{CC}^+ = +5V$ ,  $V_{CC}^- = GND$ ,  $T_{amb} = 25^{\circ}C$  (unless otherwise specified)

Symbol	Parameter	LM139A - LM239A LM339A			LM139 - LM239 LM339			Unit
		Min.	Typ.	Max.	Min.	Typ.	Max.	
$V_{io}$	Input Offset Voltage – (note 2) $T_{amb} = +25^{\circ}C$ $T_{min.} \leq T_{amb} \leq T_{max.}$		1	2 4		1	5 9	mV
$I_{io}$	Input Offset Current $T_{amb} = +25^{\circ}C$ $T_{min.} \leq T_{amb} \leq T_{max.}$		3	25 100		5	50 150	nA
$I_{ib}$	Input Bias Current ( $I_{I^+}$ or $I_{I^-}$ ) - (note 3) $T_{amb} = +25^{\circ}C$ $T_{min.} \leq T_{amb} \leq T_{max.}$		25	100 300		25	250 400	nA
$A_{vd}$	Large Signal Voltage Gain ( $V_{CC} = 15V$ , $R_L = 15k\Omega$ , $V_O = 1$ to $11V$ )	50	200		50	200		V/mV
$I_{CC}$	Supply Current (all comparators) $V_{CC} = +5V$ , no load $V_{CC} = +30V$ , no load		1.1 1.3	2 2.5		1.1 1.3	2 2.5	mA
$V_{icm}$	Input Common Mode Voltage Range - (note 4) ( $V_{CC} = 30V$ ) $T_{amb} = +25^{\circ}C$ $T_{min.} \leq T_{amb} \leq T_{max.}$	0 0		$V_{CC}^+ - 1.5$ $V_{CC}^+ - 2$	0 0		$V_{CC}^+ - 1.5$ $V_{CC}^+ - 2$	V
$V_{id}$	Differential Input Voltage - (note 6)			$V_{CC}^+$			$V_{CC}^+$	V
$V_{OL}$	Low Level Output Voltage ( $V_{id} = -1V$ , $I_{sink} = 4mA$ ) $T_{amb} = +25^{\circ}C$ $T_{min.} \leq T_{amb} \leq T_{max.}$		250	400 700		250	400 700	mV
$I_{OH}$	High Level Output Current ( $V_{id} = 1V$ ) ( $V_{CC} = V_O = 30V$ ) $T_{amb} = +25^{\circ}C$ $T_{min.} \leq T_{amb} \leq T_{max.}$		0.1	1		0.1	1	nA $\mu A$
$I_{sink}$	Output Sink Current ( $V_{id} = -1V$ , $V_O = 1.5V$ )	6	16		6	16		mA
$t_{re}$	Response Time – (note 5) ( $R_L = 5.1k\Omega$ connected to $V_{CC}^+$ )		1.3			1.3		$\mu s$
$t_{rel}$	Large Signal Response Time ( $R_L = 5.1k\Omega$ connected to $V_{CC}^+$ , $e_i = TTL$ , $V_{(ref)} = +1.4V$ )		300			300		ns

- Notes :**
- At output switch point,  $V_O \approx 1.4V$ ,  $R_S = 0$  with  $V_{CC}^+$  from 5V to 30V, and over the full input common-mode range (0V to  $V_{CC}^+ - 1.5V$ ).
  - The direction of the input current is out of the IC due to the PNP input stage. This current is essentially constant, independent of the state of the output, so no loading charge exists on the reference of input lines.
  - The input common-mode voltage of either input signal voltage should not be allowed to go negative by more than 0.3V. The upper end of the common-mode voltage range is  $V_{CC}^+ - 1.5V$ , but either or both inputs can go to +30V without damage.
  - The response time specified is for a 100mV input step with 5mV overdrive. For larger overdrive signals 300ns can be obtained.
  - Positive excursions of input voltage may exceed the power supply level. As long as the other voltage remains within the common-mode range, the comparator will provide a proper output state. The low input voltage state must not be less than -0.3V (or 0.3V below the negative power supply, if used).

SUPPLY CURRENT versus SUPPLY VOLTAGE

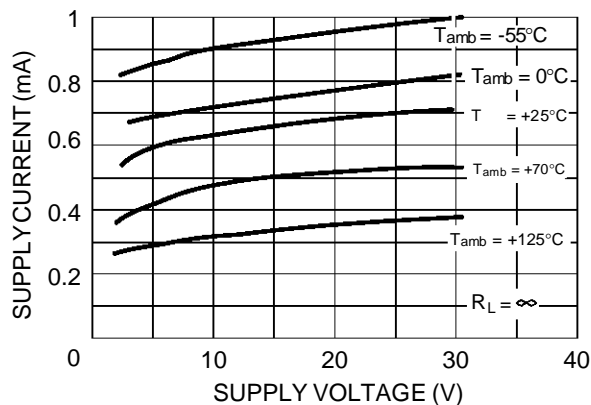

INPUT CURRENT versus SUPPLY VOLTAGE

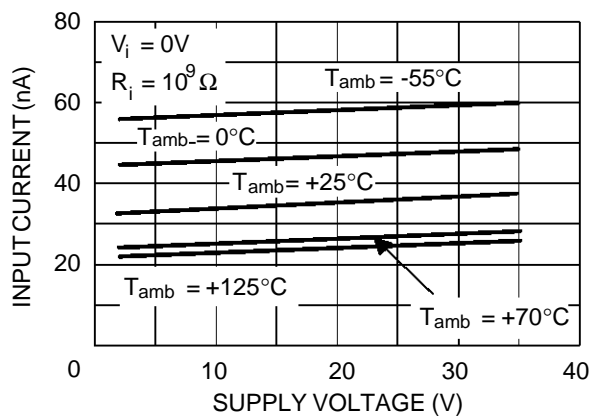

OUTPUT SATURATION VOLTAGE versus OUTPUT CURRENT

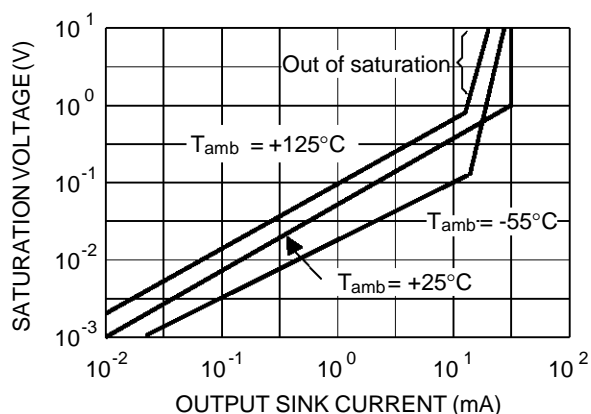

RESPONSE TIME FOR VARIOUS INPUT OVERDRIVES - NEGATIVE TRANSITION

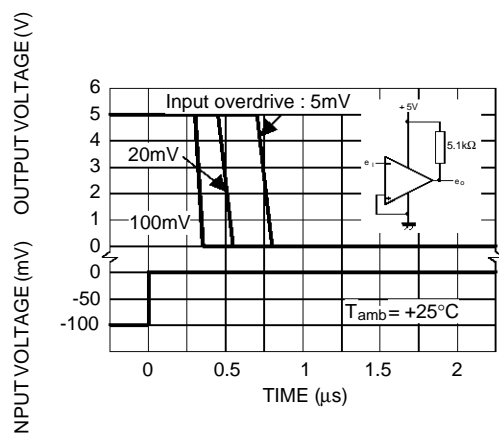

RESPONSE TIME FOR VARIOUS INPUT OVERDRIVES - POSITIVE TRANSITION

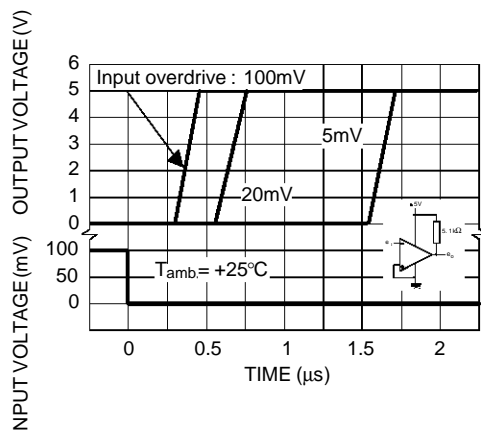

TYPICAL APPLICATIONS

BASIC COMPARATOR

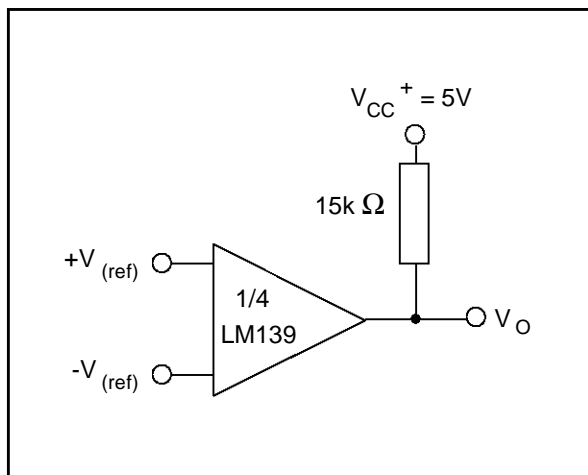

DRIVING CMOS

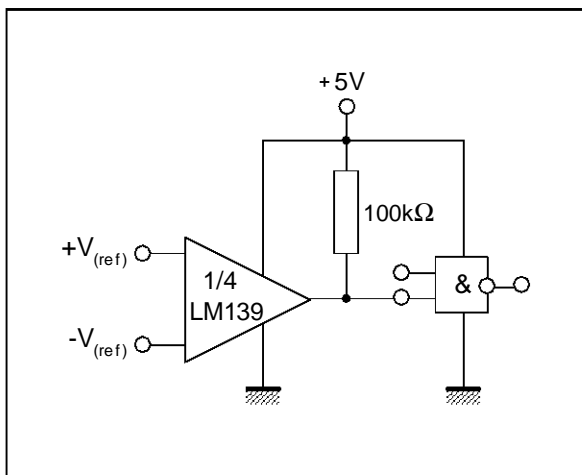

DRIVING TTL

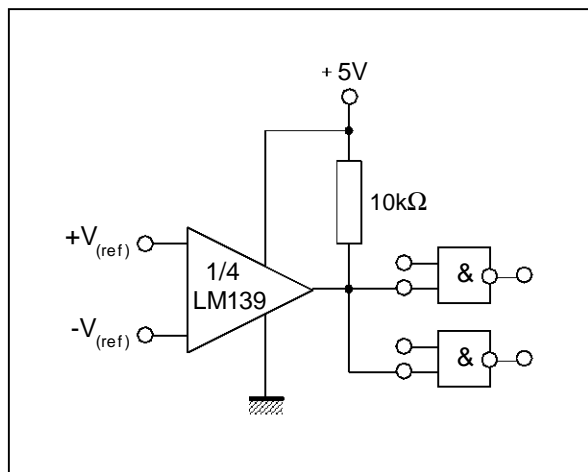

LOW FREQUENCY OP AMP

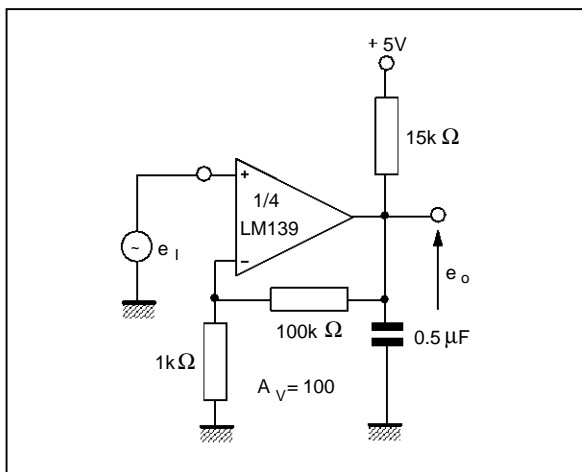

LOW FREQUENCY OP AMP

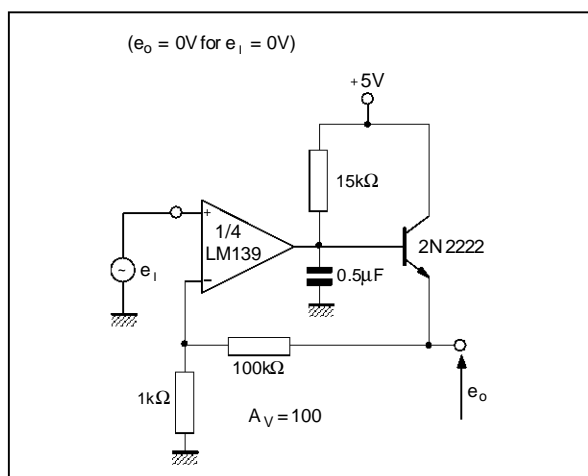

TRANSDUCER AMPLIFIER

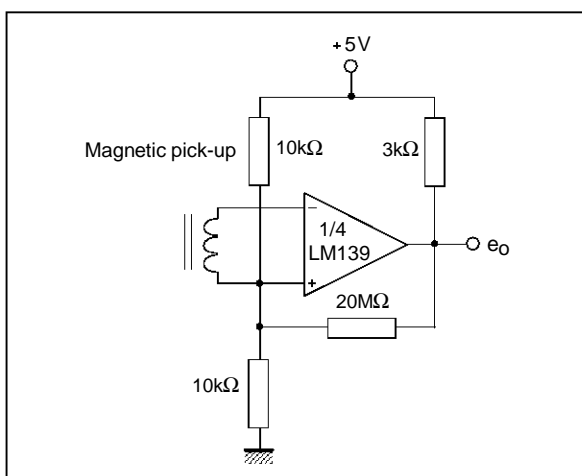

TYPICAL APPLICATIONS (continued)

TIME DELAY GENERATOR

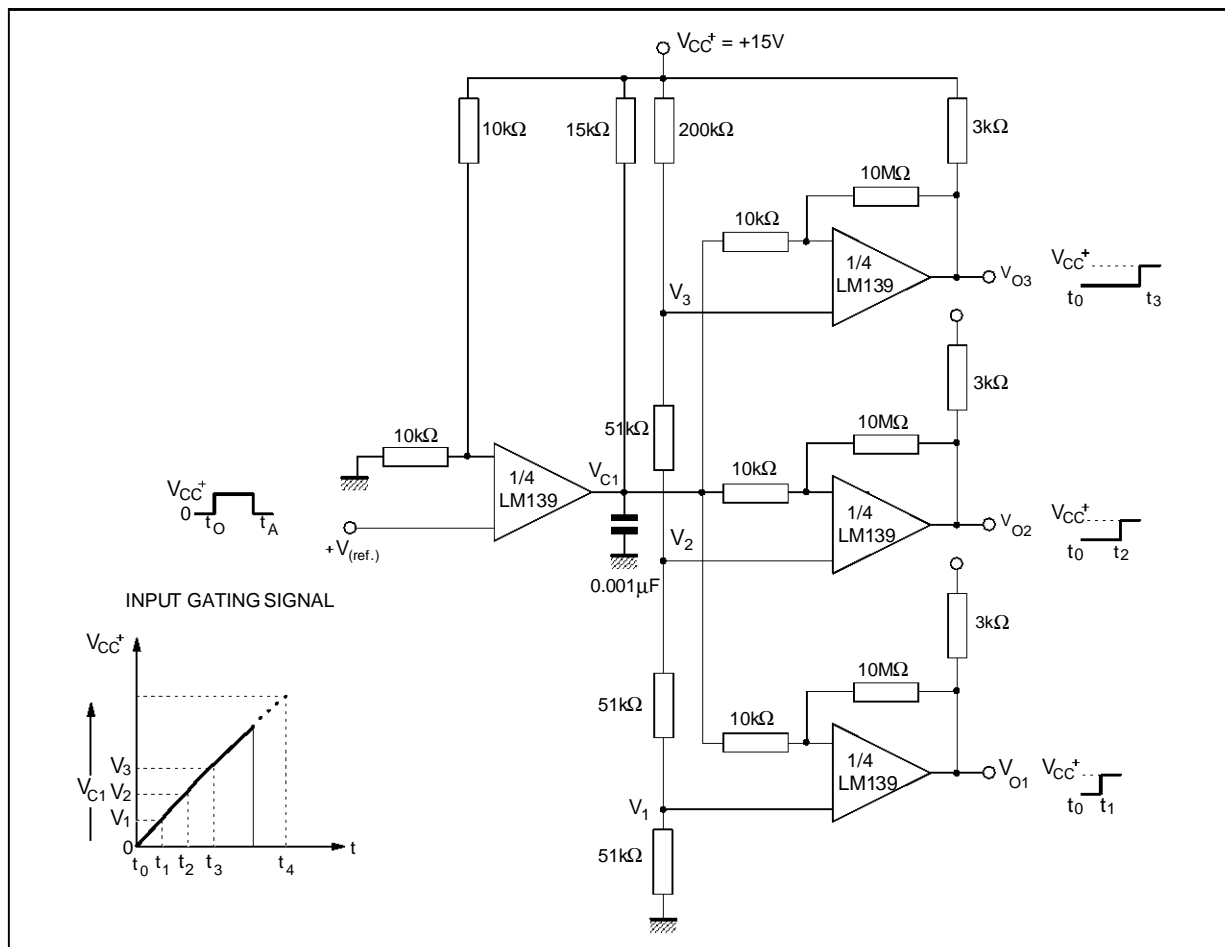

LOW FREQUENCY OP AMP WITH OFFSET ADJUST

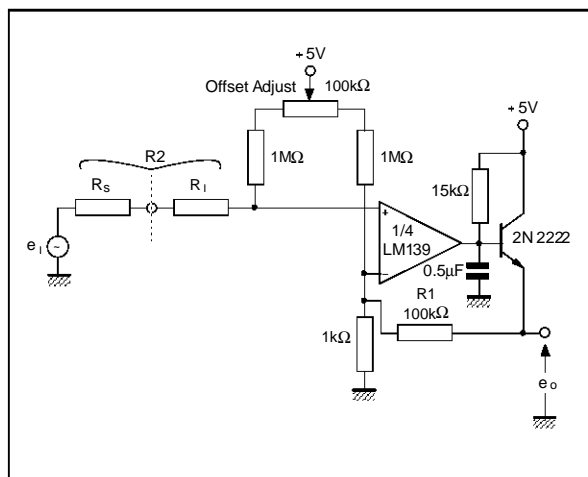

ZERO CROSSING DETECTOR (single power supply)

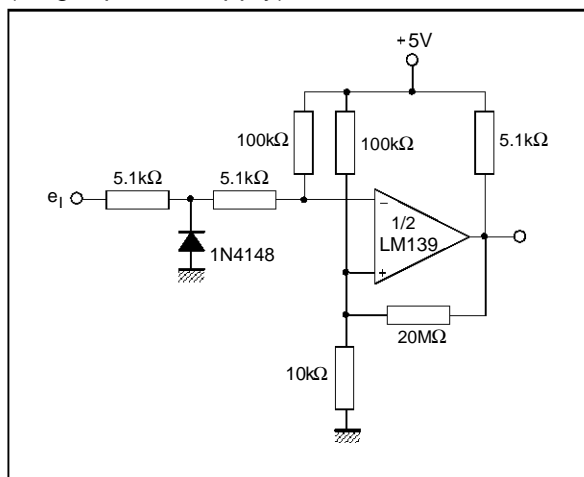

**TYPICAL APPLICATIONS** (continued)

**TWO-DECADE HIGH-FREQUENCY VCO**

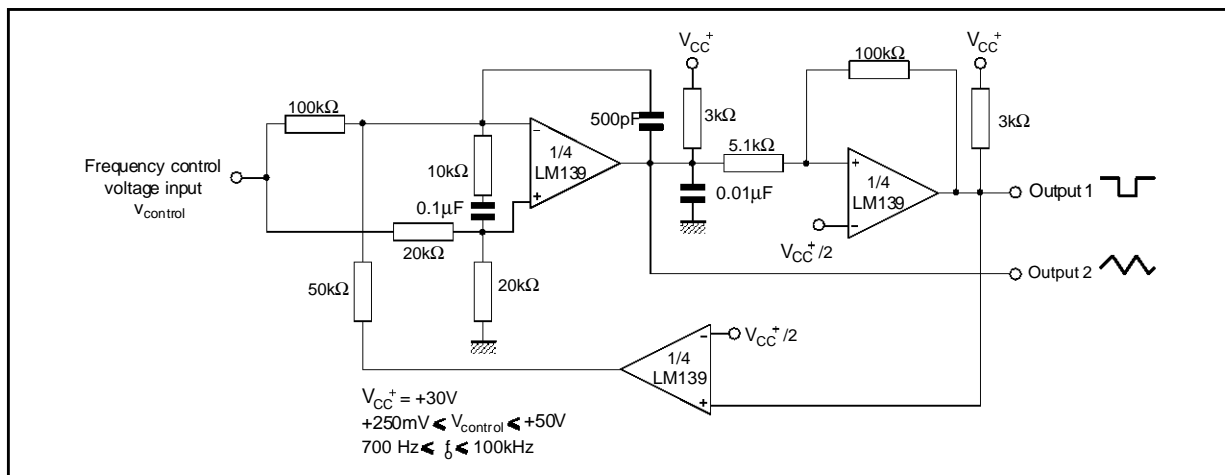

**LIMIT COMPARATOR**

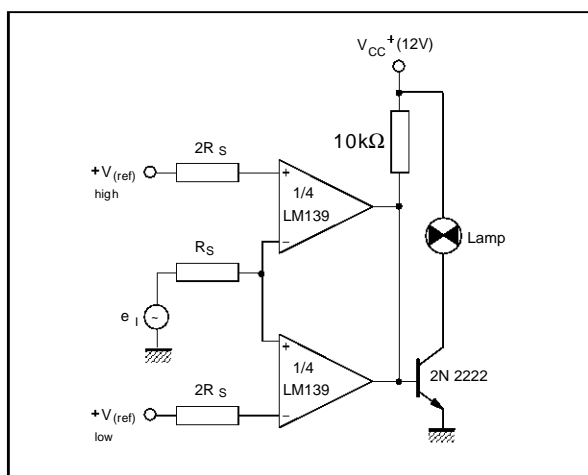

**CRYSTAL CONTROLLED OSCILLATOR**

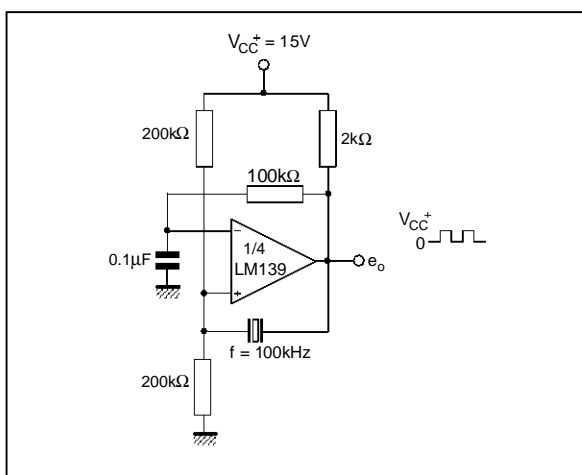

**SPLIT-SUPPLY APPLICATIONS**

**ZERO CROSSING DETECTOR**

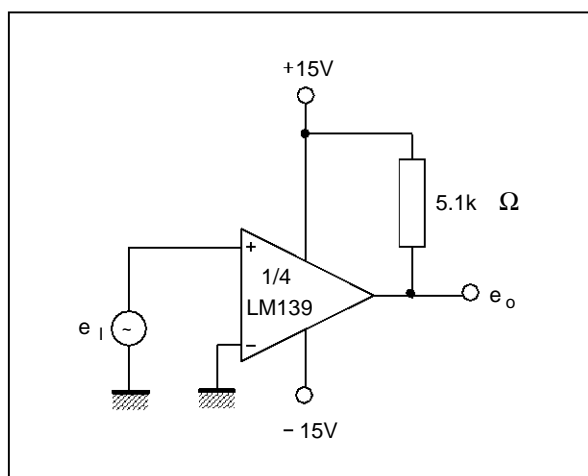

**COMPARATOR WITH A NEGATIVE REFERENCE**

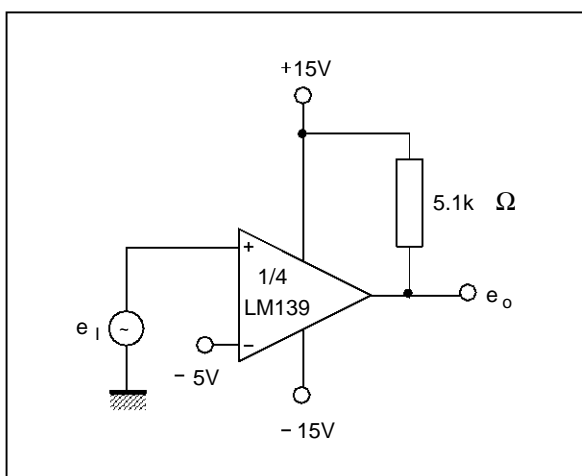

**PACKAGE MECHANICAL DATA**  
14 PINS - PLASTIC DIP

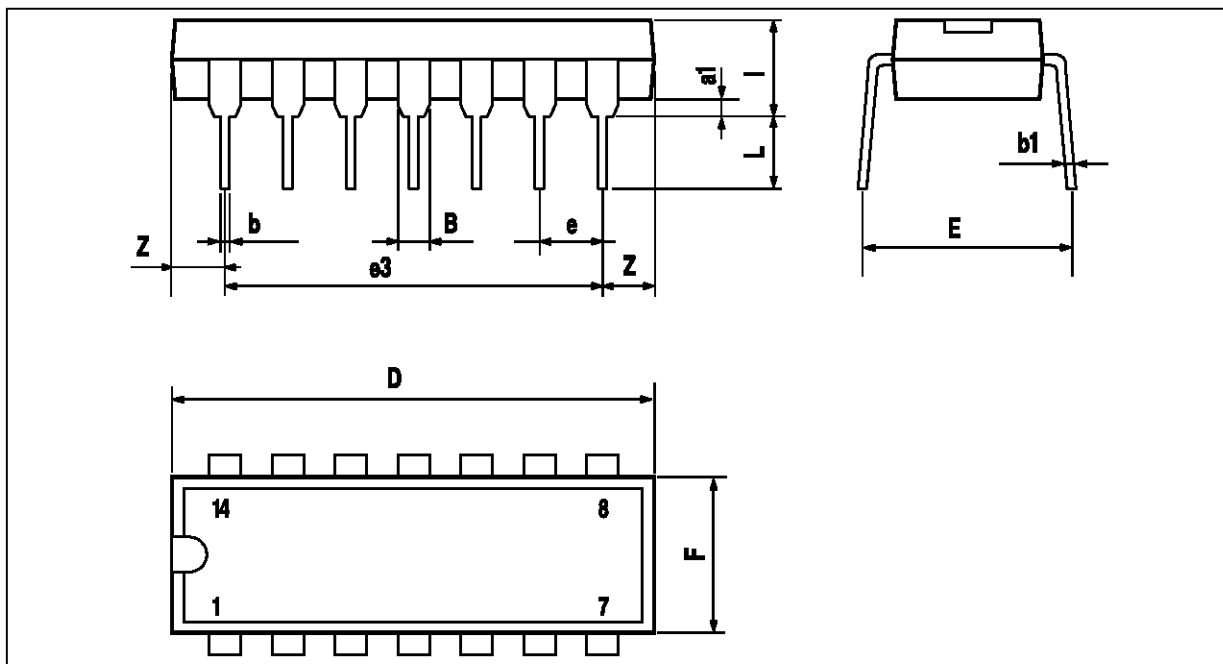

PM-DIP14.EPS

Dimensions	Millimeters			Inches		
	Min.	Typ.	Max.	Min.	Typ.	Max.
a1	0.51			0.020		
B	1.39		1.65	0.055		0.065
b		0.5			0.020	
b1		0.25			0.010	
D			20			0.787
E		8.5			0.335	
e		2.54			0.100	
e3		15.24			0.600	
F			7.1			0.280
i			5.1			0.201
L		3.3			0.130	
Z	1.27		2.54	0.050		0.100

DIP14.TBL



**PACKAGE MECHANICAL DATA**  
14 PINS - PLASTIC MICROPACKAGE (SO)

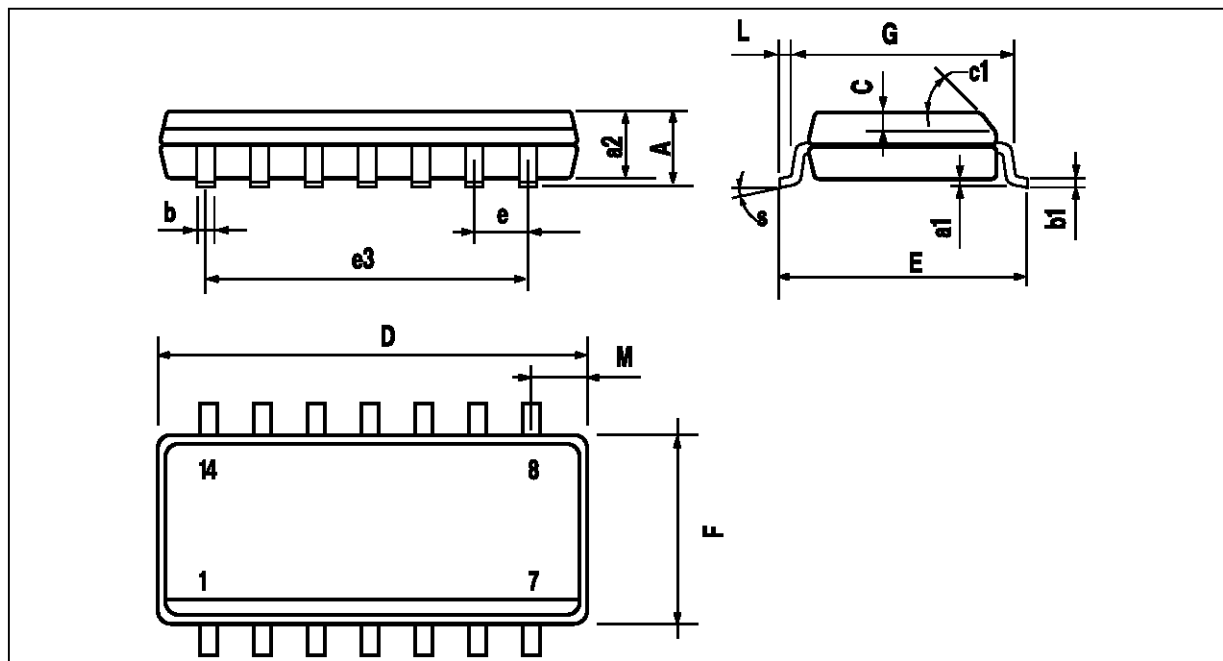

PM-SO14.EPS

Dimensions	Millimeters			Inches		
	Min.	Typ.	Max.	Min.	Typ.	Max.
A			1.75			0.069
a1	0.1		0.2	0.004		0.008
a2			1.6			0.063
b	0.35		0.46	0.014		0.018
b1	0.19		0.25	0.007		0.010
C		0.5			0.020	
c1	45° (typ.)					
D	8.55		8.75	0.336		0.334
E	5.8		6.2	0.228		0.244
e		1.27			0.050	
e3		7.62			0.300	
F	3.8		4.0	0.150		0.157
G	4.6		5.3	0.181		0.208
L	0.5		1.27	0.020		0.050
M			0.68			0.027
S	8° (max.)					

SO14.TBL

Information furnished is believed to be accurate and reliable. However, SGS-THOMSON Microelectronics assumes no responsibility for the consequences of use of such information nor for any infringement of patents or other rights of third parties which may result from its use. No license is granted by implication or otherwise under any patent or patent rights of SGS-THOMSON Microelectronics. Specification mentioned in this publication are subject to change without notice. This publication supersedes and replaces all information previously supplied. SGS-THOMSON Microelectronics products are not authorized for use as critical components in life support devices or systems without express written approval of SGS-THOMSON Microelectronics.

© 1997 SGS-THOMSON Microelectronics – Printed in Italy – All Rights Reserved

SGS-THOMSON Microelectronics GROUP OF COMPANIES  
Australia - Brazil - Canada - China - France - Germany - Hong Kong - Italy - Japan - Korea - Malaysia - Malta - Morocco  
The Netherlands - Singapore - Spain - Sweden - Switzerland - Taiwan - Thailand - United Kingdom - U.S.A.

ORDER CODE :