

**Features**

- Operating voltage: 2.4~4.0V
- On-chip SRAM
- Robot function
- Vibrato function
- 8kHz sampling rate
- 7-step level shifting
- 8-bit A/D and D/A converters
- LED indicator with voice level
- Push button selection or electronic mode
- Few external components required
- 16-pin/18-pin DIP package

**Applications**

- Toys
- Mixers
- Recorders
- Audio system
- Speech system
- Telephone system

**General Description**

The HT8950 is a single chip CMOS LSI voice modulator. It provides 7 steps to shift the frequency of an input voice, producing a dramatical change in the output.

The HT8950 provides two special effects: Vibrato and Robot. The Vibrato effect is generated by alternating the frequency of an input signal up and down at a rate of 8Hz. The Robot function, on the other hand, converts an input voice into a Robot voice. Both effects can be selected depending on which pin is triggered, either ROB or VIB. For the output frequency level shifting, the chip provides 7 steps which can be selected from the two groups of pins namely,

SW0, SW1 and SW2 for electronic direct selection and ROB, TGD, TGU and VIB for push button selection.

The HT8950 includes a built-in microphone amplifier with an internal bias, an 8-bit A/D converter, a built-in SRAM as well as a current output type 8-bit D/A converter. The 8-bit A/D and D/A converters with a sampling rate of 8kHz ensures a high quality and high S/N ratio output voice. The chip provides an LED indicator which flashes with the volume of the input voices. It is offered in a 16-pin or 18-pin DIP package.

**Pin Assignment**

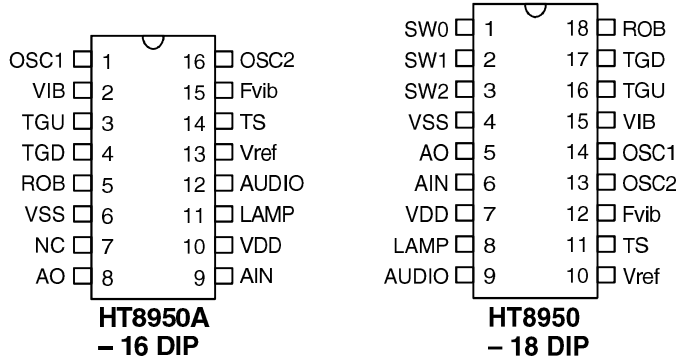

**Block Diagram**

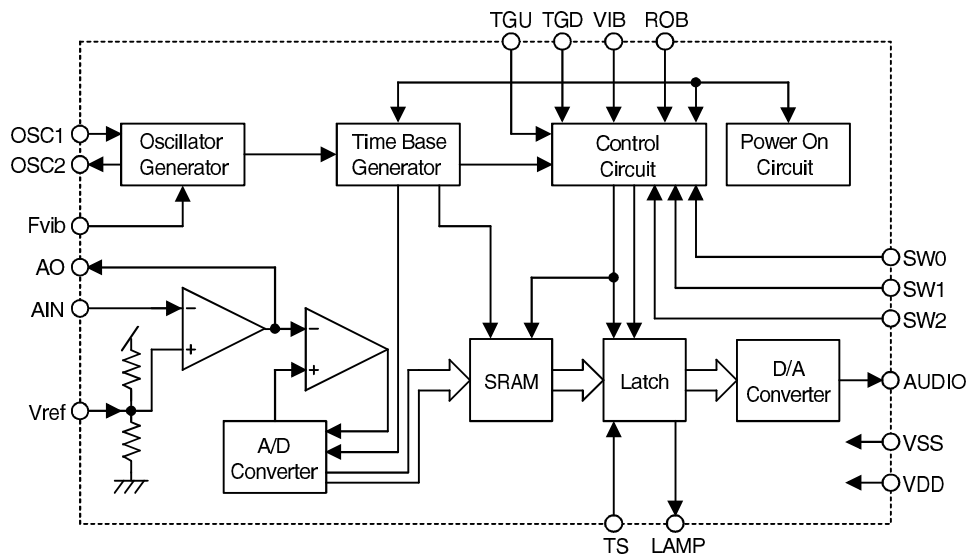

**Pad Coordinates**

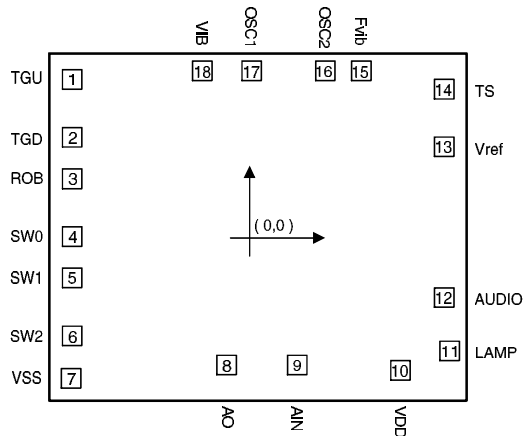
 Unit:  $\mu\text{m}$ 

Pad No.	X	Y	Pad No.	X	Y
1	-957.0	720.5	10	732.0	-774.0
2	-957.0	423.5	11	984.0	-675.0
3	-957.0	210.0	12	956.5	-400.0
4	-957.0	-87.0	13	956.5	374.5
5	-957.0	-299.5	14	956.5	671.5
6	-957.0	-596.5	15	530.5	765.5
7	-962.0	-815.0	16	345.50	765.5
8	-161.5	-747.5	17	-33.50	765.5
9	200.5	-747.5	18	-287.50	765.5

 Chip size:  $2350 \times 2080 (\mu\text{m})^2$ 

\* The IC substrate should be connected to VSS in the PCB layout artwork.

**Pin Description (18 Pin Version)**

Pin No.	Pin Name	I/O	Internal Connection	Description
1	SW0	I	Pull-High	Function setting pin (for electronic setting)
2	SW1	I	Pull-High	Function setting pin (for electronic setting)
3	SW2	I	Pull-High	Function setting pin (for electronic setting)
4	VSS	I	—	Negative power supply (GND)
5	AO	O	—	Internal amplifier output
6	AIN	I	—	Internal amplifier input (inverted)
7	VDD	O	—	Positive power supply
8	LAMP	O	NMOS Open Drain	Lamp output (brightness changes with voice volume)
9	AUDIO	O	PMOS Open Drain	Audio output
10	Vref	I	—	Internal amplifier reference voltage
11	TS	I	—	For IC test only
12	Fvib	O	—	Vibrato frequency control
13	OSC2	O	—	Oscillator output
14	OSC1	I	—	Oscillator input
15	VIB	I	Pull-High	Switch to Vibrato mode (toggle)

Pin No.	Pin Name	I/O	Internal Connection	Description
16	TGU	I	Pull-High	Switch to Upward step mode
17	TGD	I	Pull-High	Switch to Downward step mode (internal pull-high)
18	ROB	I	Pull-High	Switch to Robot mode (internal pull-high)

**Absolute Maximum Ratings\***

Supply Voltage ..... -0.3V to 6V      Storage Temperature..... -50°C to 125°C  
 Input Voltage.....  $V_{SS}-0.3V$  to  $V_{DD}+0.3V$       Operating Temperature..... -20°C to 70°C

\*Note: These are stress ratings only. Stresses exceeding the range specified under “Absolute Maximum Ratings” may cause substantial damage to the device. Functional operation of this device at other conditions beyond those listed in the specification is not implied and prolonged exposure to extreme conditions may affect device reliability.

**Electrical Characteristics**

(Ta=25°C)

Symbol	Parameter	Test Conditions		Min.	Typ.	Max.	Unit
		V <sub>DD</sub>	Conditions				
V <sub>DD</sub>	Operating Voltage	—	—	2.4	3.0	4.0	V
I <sub>OP</sub>	Operating Current	3V	No load, f <sub>OSC</sub> =640kHz	—	2.0	10	mA
V <sub>IN</sub>	Input Signal	3V	—	—	—	580	mV
I <sub>LAMP</sub>	Lamp Sink Current	3V	V <sub>OL</sub> =1.3V	5.0	9.5	—	mA
A <sub>V</sub>	OPA Gain Value	3V	Open loop	—	2000	—	
I <sub>O</sub>	Audio Output Voltage	3V	During silence	—	-1.0	—	mA
V <sub>IH</sub>	“H” Input Voltage	—	—	0.7V <sub>DD</sub>	—	—	V
V <sub>IL</sub>	“L” Input Voltage	—	—	—	—	0.3V <sub>DD</sub>	V
f <sub>OSC</sub>	Oscillating Frequency	3V	R <sub>OSC</sub> =47kΩ	—	512	—	kHz

**Functional Description**

The HT8950 is a single chip LSI designed for voice modulation. It provides 7 steps to shift the frequency of an input voice signal up and down. The chip is also equipped with two special effects; Vibrato and Robot.

The HT8950 includes a built-in amplifier, 8-bit A/D converter and current output type of 8-bit D/A converter in addition to a built-in SRAM. The brightness of an LED indicator changes with the volume of the input voice signal.

**Power on initial**

The HT8950 enters the Robot state right after power is initially switched on.

**Robot state**

The system goes into the Robot state after the ROB pin is triggered or power is turned on. In this mode, an input voice can be converted into a robot voice.

**Vibrato**

An output voice will be generated with a vibrato effect when the VIB pin is triggered, regardless of what state the system is in. The vibrato effect is toggle activated. In other words, when a voice output is playing with a vibrato effect, this effect can be eliminated by retriggering the VIB pin. The rate of vibrato effect can be changed by adjusting the resistance of the external resistor between the OSC2 and Fvil pins.

**Voice modulation**

The HT8950 provides an 8-bit A/D and a D/A converters with a sampling rate of 8kHz, ensuring a voice output of high quality and with a high S/N ratio. The chip includes 7 steps to shift

the frequency of an input signal. The voice modulation is selected and determined by the SW0~SW2 inputs.

Input			Step Mode	Speed Ratio
SW2	SW1	SW0		
1	1	1	Controlled by TGU and TDG	Notes
1	1	0	UP3	2
1	0	1	UP2	8/5
1	0	0	UP1	4/3
0	1	1	NORMAL	1
0	1	0	DN1	8/9
0	0	1	DN2	4/5
0	0	0	DN3	2/3

Notes: The TGU switch elevates by one step mode, and the TGD switch, on the other hand, falls one step mode step by step as shown:

- The system changes to the Robot state after the ROB pin is triggered, regardless of what state the system is in.
- A voice output is accompanied with a vibrato effect after the VIB pin is triggered, regardless of what state the system is in.

**LED indicator**

The HT8950 provides a LAMP pin to drive an external LED. The brightness of LED changes with the volume of the input voice signal.

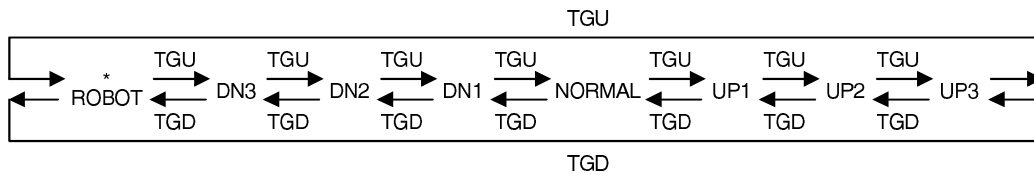

Application Circuits

16-pin version with an LM386 power amplifier and a 6V power supply

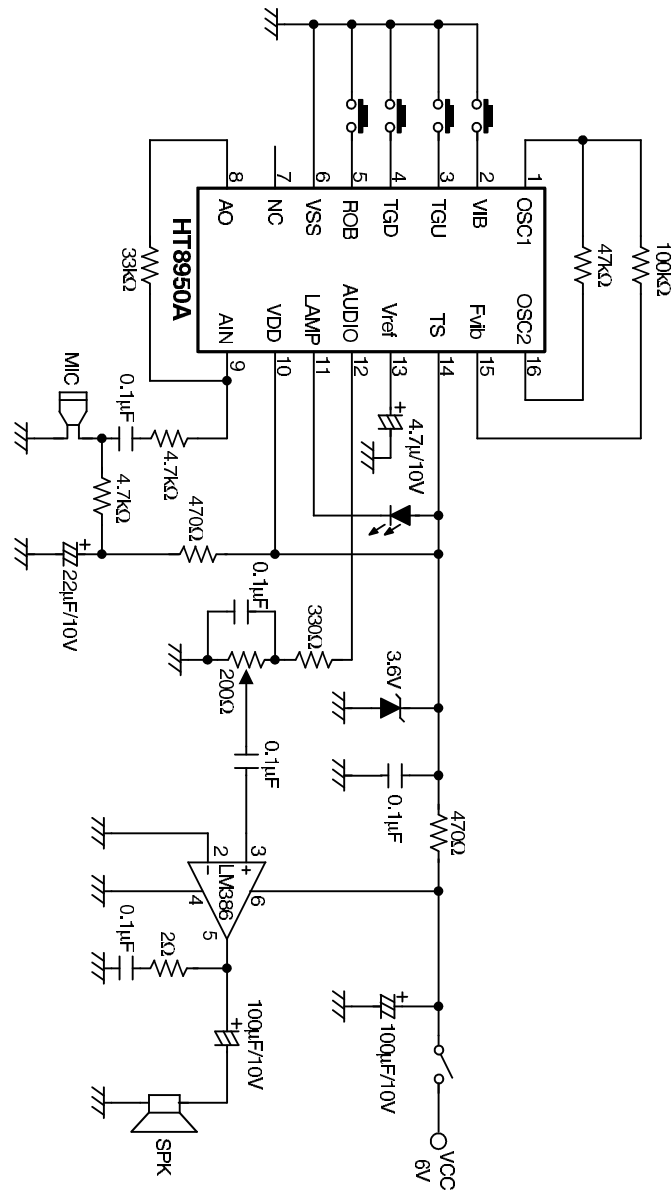



16-pin version with a transistor output stage and a 6V power supply

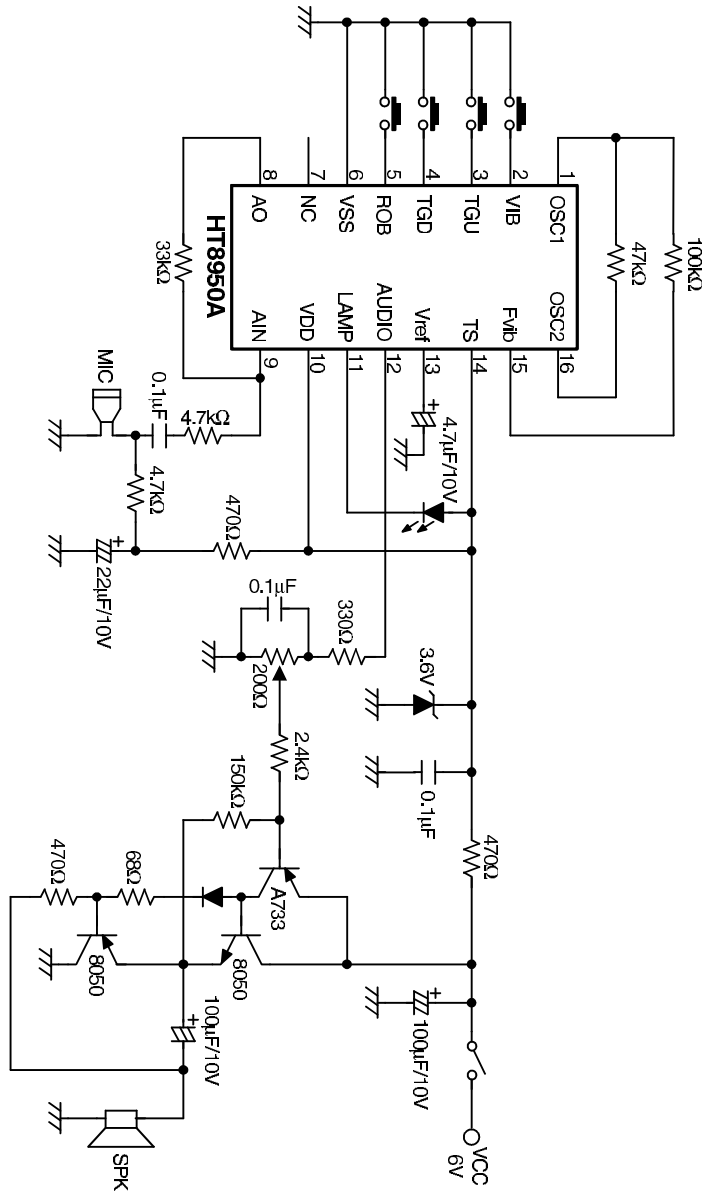



18-pin version with a transistor output stage and a 6V power supply

