

Features

- High noise immunity CMOS technology
- Operating voltage: 9V~12V
- High sensitivity and stability
- Polarity insensitive with AC line
- Minimum external components
- Two types of input (Touch-Sense/Key-Trigger) in one chip
- Low power dissipation
- Loading range of sense input from 0 to 1200pf
- Dimmer function: 96 steps or ON/OFF switch
- 50/60Hz selectable
- 8-pin DIP package

Applications

- Light control

General Description

The HT7700 series is a CMOS fabricated LSI in an 8-lead DIP package. It is designed to control the brightness of an incandescent lamp by changing the triggering angles of the TRIAC with a touch sense input or a key trigger input.

For the key trigger type, if the key is pressed more than 0.7 seconds, the brightness will decrease smoothly until the key is released. If the key is continually held down, the lamp will eventually turn off. But if the key is pressed less than 0.7 seconds, the lamp will switch between

the “ON” and “OFF” states.

For the touch sense type, the first touch will emit the brightest light. The second touch will make it fade away gradually. The third touch will maintain the level of brightness. The fourth will turn it off completely.

There are four types of processor in the series, namely Key-Trigger (7700A,50Hz), Key-Trigger (7700B,60Hz), Touch-Sense (7700C,50Hz), and Touch-Sense (7700D,60Hz).

Pin Assignment

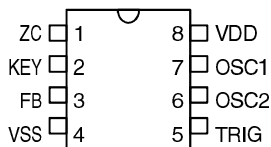

Key-trigger-type
HT7700A (50Hz)
HT7700B (60Hz)
- 8 DIP

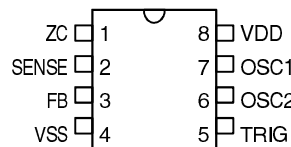

Touch-sense type
HT7700C (50Hz)
HT7700D (60Hz)
- 8 DIP

Pad Coordinates

Unit: mil

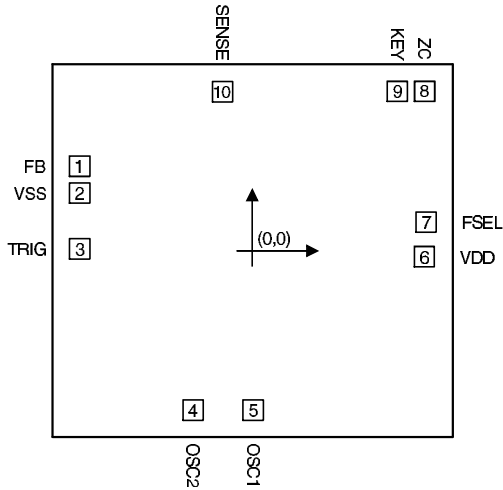

Pad No.	X	Y
1	-51.21	25.11
2	-51.21	17.06
3	-51.26	0.50
4	-17.53	-47.41
5	0.38	-47.41
6	51.12	-1.8
7	51.66	8.46
8	51.21	47.34
9	43.11	47.34
10	-8.80	47.18

Chip size: $116 \times 108 \text{ (mil)}^2$

* The IC substrate should be connected to VSS in the PCB layout artwork.

Block Diagram

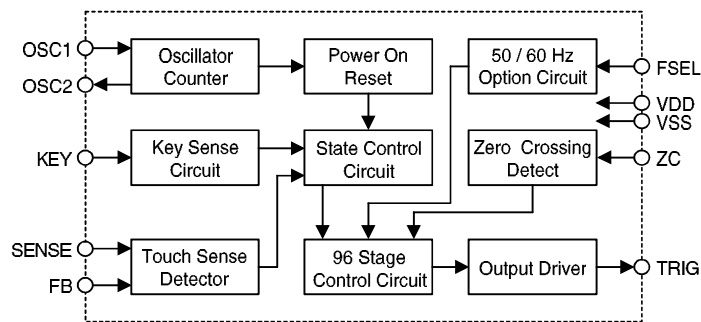

Pad Description

Pad No.	Pad Name	I/O	Description
1	FB	I	Feedback signal to control the sink current of SENSOR pin
2	VSS	I	Negative power supply
3	TRIG	O	Trigger output to drive the TRIAC
4	OSC2	O	Oscillator output
5	OSC1	I	Oscillator input
6	VDD	I	Positive power supply
7	FSEL	I	For 50Hz or 60Hz select (open=60Hz, internal pull low)
8	ZC	I	Line frequency 60Hz or 50Hz input for zero crossing
9	KEY	I	Key input (internal pull high)
10	SENSE	I	Touch sense input

Absolute Maximum Rating*

Supply Voltage -0.3V to 13V Storage Temp -50°C to 125°C
 Input Voltage..... $V_{SS}-0.3V$ to $V_{DD}+0.3V$ Operating Temp 0°C to 70°C

*Note: Stresses above those listed under “Absolute Maximum Ratings” may cause permanent damage to the device. These are stress ratings only. Functional operation of this device at these or any other conditions above those indicated in the operational sections of this specification is not implied and exposure to absolute maximum rating conditions for extended periods may affect device reliability.

Electrical Characteristics

(Ta=25°C)

Symbol	Parameter	Test Conditions		Min.	Typ.	Max.	Unit
		V _{DD}	Conditions				
V _{DD}	Operating Voltage	—	—	9	—	12	V
I _{DD}	Operating Current	9V	No load	—	1	2	mA
F _{OSC}	System Frequency	9V	R _{OSC} =62kΩ	—	320	—	kHz
I _{OL}	TRIG Sink Current	9V	V _{OL} =0.9V	—	14	—	mA
I _{OH}	TRIG Driver Current	9V	V _{OH} =8.1V	—	-0.2	—	mA
V _{IH}	“H” Input Voltage	—	—	0.8V _{DD}	—	—	V
V _{IL}	“L” Input Voltage	—	—	—	—	0.2V _{DD}	V

Functional Description

Key trigger type (HT7700A, HT7700B)

Touch sense type (HT7700C, HT7700D)

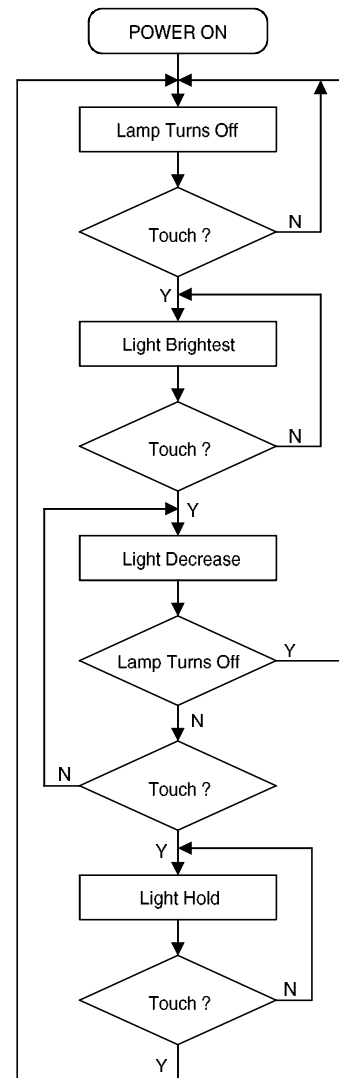
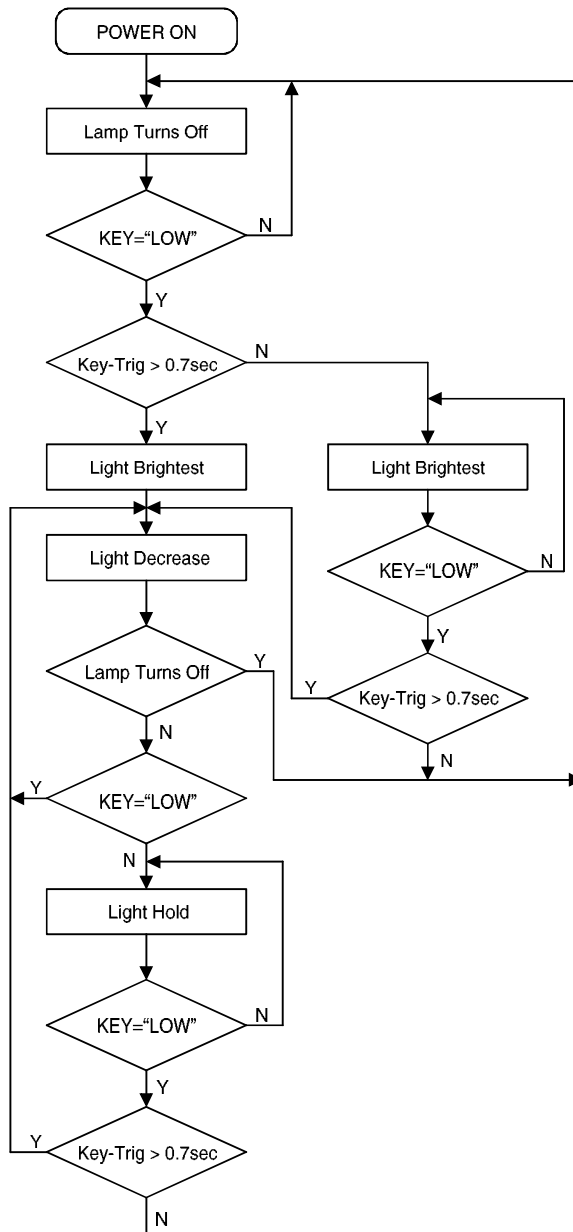

Application Circuit

Key trigger input

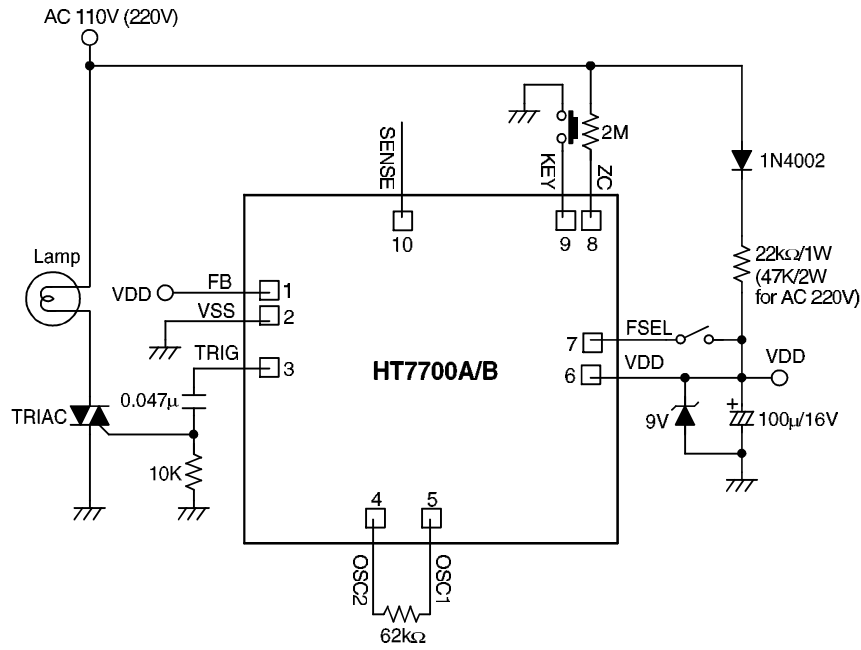

* The IC substrate should be connected to VSS in the PCB layout artwork.

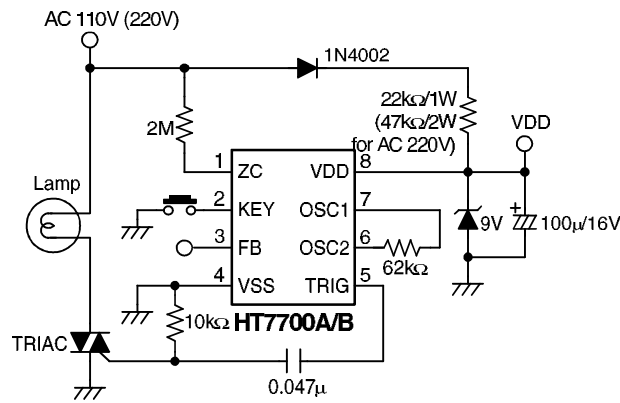

Touch sense input

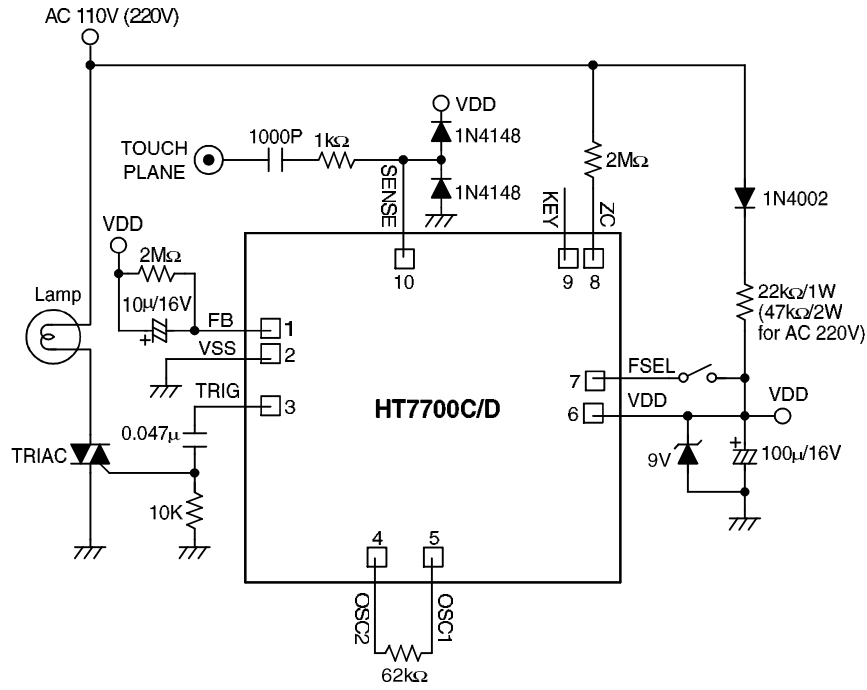

* The IC substrate should be connected to VSS in the PCB layout artwork.

