

Features

- C-MOS Metal-Gate Process
- Operating voltage: 1.2V~4.5V
- Low stand-by current: 1 μ A at 3V
- A five lamp flash driver
- Random or sequence flash
- On/Off toggle control
- 1/10 duty cycle output
- A built-in oscillator
- Minimum external components

General Description

The HT2050 is a low cost, low-power CMOS fabricated LSI chip designed for lamp and LED flash drivers. It contains five flash outputs. Each flash output is with a 10mA capability that can implement random or sequential flash-

ing controlled by a single option pin. The chip requires only one external resistor for normal applications. It is very suitable for use in products that require flashing lights, such as gift cards, Christmas decoration, etc.

Pin Assignment

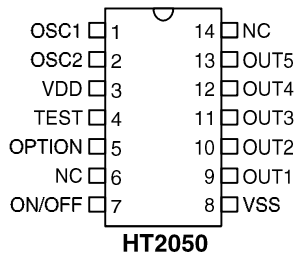

Block Diagram

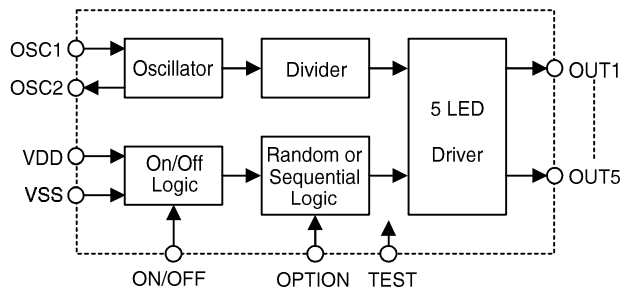

Pad Coordinates

Unit: mil

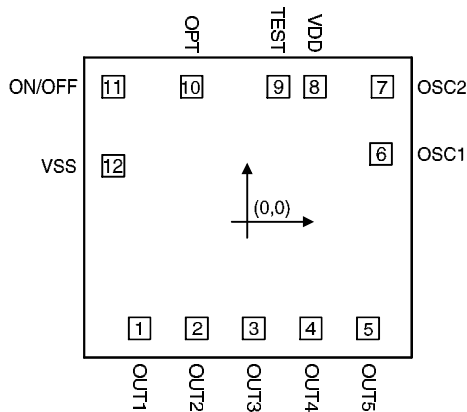

Pad No.	X	Y	Pad No.	X	Y
1	-21.09	-20.9	7	26.55	26.5
2	-9.89	-20.9	8	13.35	26.5
3	1.31	-20.9	9	6.15	26.5
4	12.51	-20.9	10	-10.89	26.5
5	23.71	-20.9	11	-26.25	26.5
6	26.23	13.3	12	-26.25	10.98

Chip size: 64 × 59 (mil)²

* The IC substrate should be connected to VDD in the PCB layout artwork.

Pad Description

Pad No.	Pad Name	I/O	Description
1	OUT1	O	Lamp/LED flash drive output
2	OUT2	O	Lamp/LED flash drive output
3	OUT3	O	Lamp/LED flash drive output
4	OUT4	O	Lamp/LED flash drive output
5	OUT5	O	Lamp/LED flash drive output
6	OSC1	I	Oscillator input
7	OSC2	O	Oscillator output
8	VDD	I	Positive power supply
9	TEST	I/O	For IC test only
10	OPTION	I	Random or sequence function selection
11	ON/OFF	I	Toggle ON/OFF control
12	VSS	I	Negative power supply, GND

Note: OPTION=VDD → Sequential Mode

OPTION=Open → Random Mode

Absolute Maximum Ratings

Supply Voltage -0.3V to 5V

Storage Temperature..... -50°C to 125°C

Input/Output Voltage ... $V_{SS}-0.3V$ to $V_{DD}+0.3V$

Operating Temperature..... 0°C to 70°C

Electrical Characteristics

Symbol	Parameter	Test Condition		Min.	Typ.	Max.	Unit
		V _{DD}	Condition				
V _{DD}	Operating Voltage	—	—	1.2	3	4.5	V
I _{STB}	Stand-by Current	3V	—	—	1	2	μA
I _{DD}	Operating Current	3V	No load	—	200	500	μA
I _{OL}	Output Sink Current	1.5V	V _{OL} =0.5V	5	8	—	mA
		3V	V _{OL} =0.5V	10	15	—	mA
F _{OSC}	Oscillator Frequency	—	R=150K~300KΩ	—	64K	—	Hz

Application Circuit

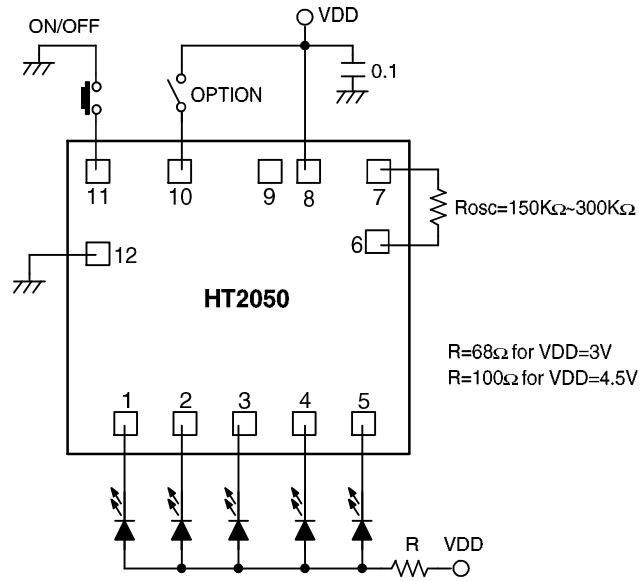

* The IC substrate should be connected to VDD in PCB layout artwork.

