

μA78L00 SERIES POSITIVE-VOLTAGE REGULATORS

SLVS010D – JANUARY 1976 – REVISED OCTOBER 1995

- 3-Terminal Regulators
- Output Current Up to 100 mA
- No External Components
- Internal Thermal Overload Protection
- Internal Short-Circuit Current Limiting
- Direct Replacements for Fairchild μA78L00 Series

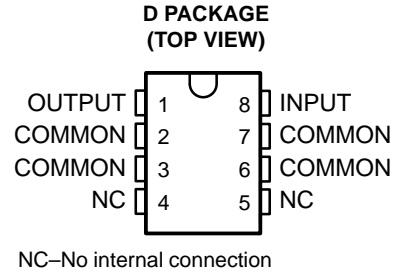

description

This series of fixed-voltage monolithic integrated-circuit voltage regulators is designed for a wide range of applications. These applications include on-card regulation for elimination of noise and distribution problems associated with single-point regulation. In addition, they can be used with power-pass elements to make high-current voltage regulators. One of these regulators can deliver up to 100 mA of output current. The internal limiting and thermal shutdown features of these regulators make them essentially immune to overload. When used as a replacement for a zener diode-resistor combination, an effective improvement in output impedance can be obtained together with lower-bias current.

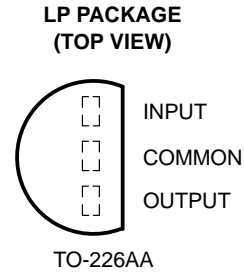

AVAILABLE OPTIONS

T _J	V _{O(nom)} (V)	PACKAGED DEVICES				CHIP FORM (Y)
		PLASTIC DIP (D)		PLASTIC CYLINDRICAL (LP)		
		OUTPUT VOLTAGE TOLERANCE				
		5%	10%	5%	10%	
0°C to 125°C	2.6	μA78L02ACD	μA78L02CD	μA78L02ACL	μA78L02CLP	μA78L02Y
	5	μA78L05ACD	μA78L05CD	μA78L05ACL	μA78L05CLP	μA78L05Y
	6.2	μA78L06ACD	μA78L06CD	μA78L06ACL	μA78L06CLP	μA78L06Y
	8	μA78L08ACD	μA78L08CD	μA78L08ACL	μA78L08CLP	μA78L08Y
	9	μA78L09ACD	μA78L09CD	μA78L09ACL	μA78L09CLP	μA78L09Y
	10	μA78L10ACD	μA78L10CD	μA78L10ACL	μA78L10CLP	μA78L10Y
	12	μA78L12ACD	μA78L12CD	μA78L12ACL	μA78L12CLP	μA78L12Y
-40°C to 125°C	5	μA78L05AQD	μA78L05QD	μA78L05QLP	μA78L05QLP	—
	12	μA78L12AQD	μA78L12QD	μA78L12QLP	μA78L12QLP	—

D and LP packages are available taped and reeled. Add R suffix to device type (e.g., μA78L05ACDR).

μ A78L00 SERIES POSITIVE-VOLTAGE REGULATORS

SLVS010D – JANUARY 1976 – REVISED OCTOBER 1995

schematic

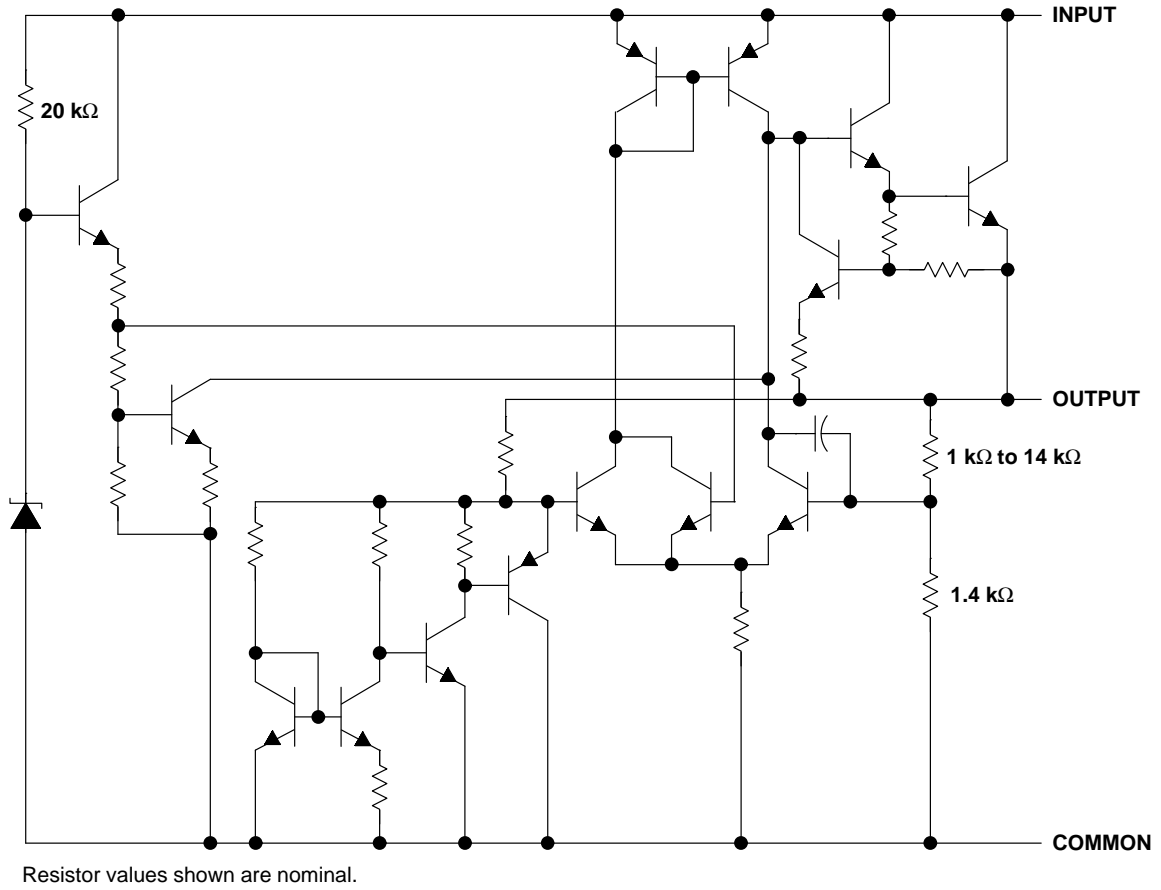

μA78xxY chip information

These chips, when properly assembled, display characteristics similar to the μA78xxY. Thermal compression or ultrasonic bonding may be used on the doped aluminum bonding pads. The chips may be mounted with conductive epoxy or a gold-silicon preform.

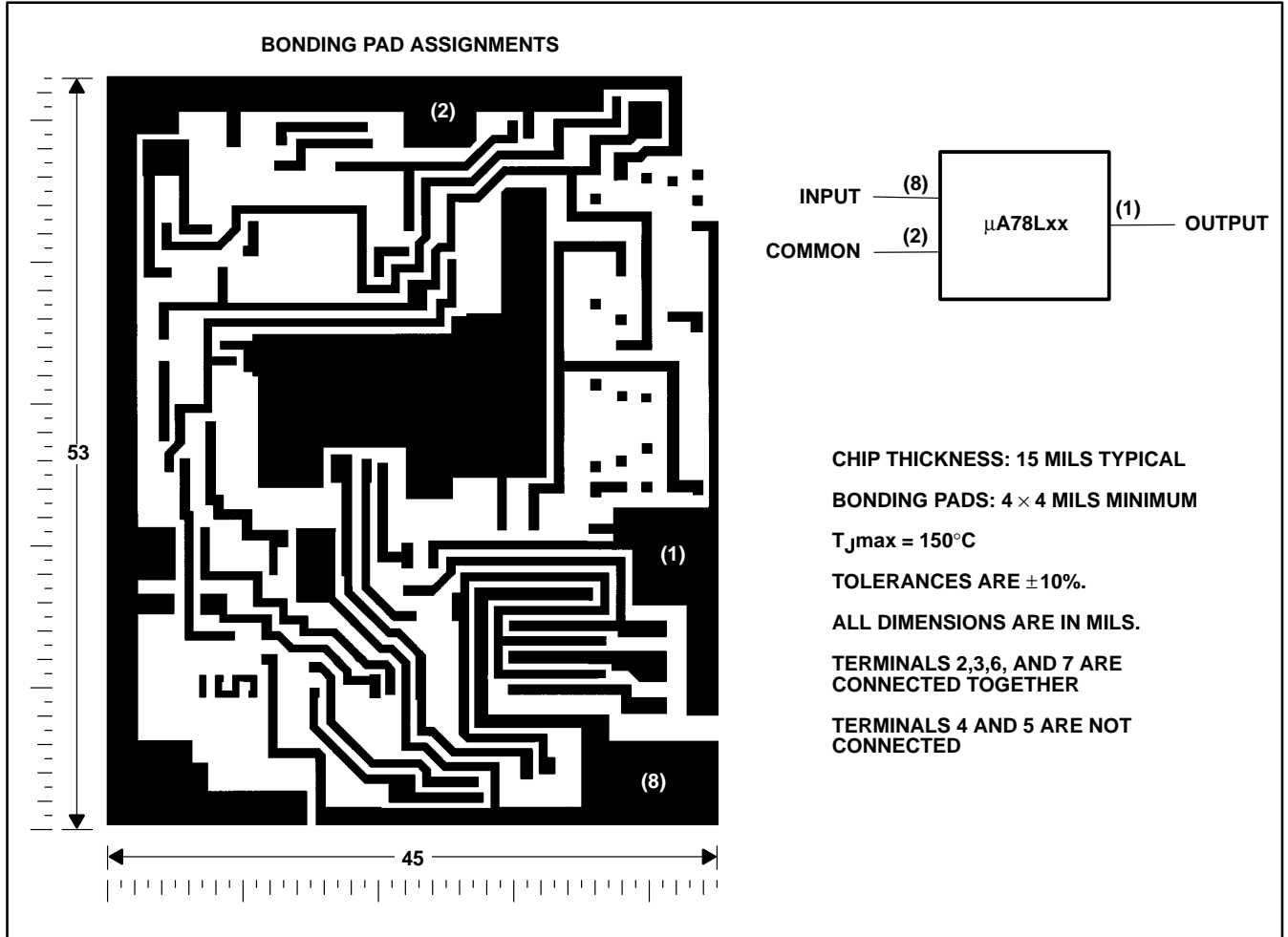

μA78L00 SERIES POSITIVE-VOLTAGE REGULATORS

SLVS010D – JANUARY 1976 – REVISED OCTOBER 1995

μA78LxxC absolute maximum ratings over operating temperature range (unless otherwise noted)

	μA78L02C, μA78L02AC THROUGH μA78L10C, μA78L10AC	μA78L12C, μA78L12AC μA78L15C, μA78L15AC	UNIT
Input voltage	30	35	V
Continuous total power dissipation (see Note 1)	See Dissipation Rating Tables 1 and 2		
Operating free-air, T_A , case, T_C , or virtual junction, T_J , temperature range	0 to 125	0 to 125	°C
Storage temperature range, T_{stg}	-65 to 150	-65 to 150	°C
Lead temperature 1,6 mm (1/16 inch) from case for 10 seconds	260	260	°C

NOTE 1: To avoid exceeding the design maximum virtual junction temperature, these ratings should not be exceeded. Due to variations in individual device electrical characteristics and thermal resistance, the built-in thermal overload protection may be activated at power levels slightly above or below the rated dissipation.

μA78LxxQ absolute maximum ratings over operating temperature range (unless otherwise noted)

	μA78L05Q, μA78L05AQ	μA78L12Q, μA78L12AQ	UNIT
Input voltage	30	35	V
Continuous total power dissipation (see Note 1)	See Dissipation Rating Tables 1 and 2		
Operating free-air, T_A , case, T_C , or virtual junction, T_J , temperature range	-40 to 150	-40 to 150	°C
Storage temperature range, T_{stg}	-65 to 150	-65 to 150	°C
Lead temperature 1,6 mm (1/16 inch) from case for 10 seconds	260	260	°C

NOTE 1: To avoid exceeding the design maximum virtual junction temperature, these ratings should not be exceeded. Due to variations in individual device electrical characteristics and thermal resistance, the built-in thermal overload protection may be activated at power levels slightly above or below the rated dissipation.

DISSIPATION RATING TABLE 1 – FREE-AIR TEMPERATURE

PACKAGE	$T_A \leq 25^\circ\text{C}$ POWER RATING	DERATING FACTOR	DERATE ABOVE T_A	$T_A = 70^\circ\text{C}$ POWER RATING
D	725 mW	5.8 mW/°C	25°C	464 mW
LP†	775 mW	6.2 mW/°C	25°C	496 mW

† The LP package dissipation rating is based on thermal resistance $R_{\theta JA}$ measured in still air with the device mounted in an Augat socket. The bottom of the package is 10 mm (0.375 in) above the socket.

DISSIPATION RATING TABLE 2 – CASE TEMPERATURE

PACKAGE	$T_A \leq 25^\circ\text{C}$ POWER RATING	DERATING FACTOR	DERATE ABOVE T_C	$T_C = 125^\circ\text{C}$ POWER RATING
D	1600 mW	19.6 mW/°C	65°C	424 mW
LP	1600 mW	28.6 mW/°C	94°C	713 mW

μA78L00 SERIES POSITIVE-VOLTAGE REGULATORS

SLVS010D – JANUARY 1976 – REVISED OCTOBER 1995

recommended operating conditions

		MIN	MAX	UNIT
Input voltage, V_I	μA78L02C, μA78L02AC	4.75	20	V
	μA78L05C, μA78L05AC, μA78L05Q, μA78L05AQ	7	20	
	μA78L06C, μA78L06AC	8.5	20	
	μA78L08C, μA78L08AC	10.5	23	
	μA78L09C, μA78L09AC	11.5	24	
	μA78L10C, μA78L10AC	12.5	25	
	μA78L12C, μA78L12AC, μA78L12Q, μA78L12AQ	14.5	27	
	μA78L15C, μA78L15AC	17.5	30	
Output current, I_O			100	mA
Operating virtual junction temperature, T_J	μA78LxxC thru μA78LxxAC	0	125	°C
	μA78LxxQ and μA78LxxAQ	-40	125	

μA78L00 SERIES POSITIVE-VOLTAGE REGULATORS

SLVS010D – JANUARY 1976 – REVISED OCTOBER 1995

electrical characteristics at specified virtual junction temperature, $V_I = 9\text{ V}$, $I_O = 40\text{ mA}$ (unless otherwise noted)

PARAMETER	TEST CONDITIONS	T_J †	μA78L02C			μA78L02AC			UNIT
			MIN	TYP	MAX	MIN	TYP	MAX	
Output voltage‡	$V_I = 4.75\text{ V to }20\text{ V}$, $I_O = 1\text{ mA to }40\text{ mA}$ $I_O = 1\text{ mA to }70\text{ mA}$	25°C	2.4	2.6	2.8	2.5	2.6	2.7	V
		Full range§	2.35		2.85	2.45		2.75	
			2.35		2.85	2.45		2.75	
Input voltage regulation	$V_I = 4.75\text{ V to }20\text{ V}$	25°C		20	125		20	100	mV
	$V_I = 5\text{ V to }20\text{ V}$			16	100		16	75	
Ripple rejection	$V_I = 6\text{ V to }20\text{ V}$, $f = 120\text{ Hz}$	25°C	42	51		43	51		dB
Output voltage regulation	$I_O = 1\text{ mA to }100\text{ mA}$	25°C		12	50		12	50	mV
	$I_O = 1\text{ mA to }40\text{ mA}$			6	25		6	25	
Output noise voltage	$f = 10\text{ Hz to }100\text{ kHz}$	25°C		30		30			μV
Dropout voltage		25°C		1.7		1.7			V
Bias current		25°C		3.6	6		3.6	6	mA
		125°C			5.5			5.5	
Bias current change	$V_I = 5\text{ V to }20\text{ V}$ $I_O = 1\text{ mA to }40\text{ mA}$	Full range§			2.5			2.5	mA
					0.2			0.1	

† Pulse-testing techniques maintain T_J as close to T_A as possible. Thermal effects must be taken into account separately. All characteristics are measured with a 0.33-μF capacitor across the input and a 0.1-μF capacitor across the output.

‡ This specification applies only for dc power dissipation permitted by absolute maximum ratings.

§ Full range virtual junction temperature is 0°C to 125°C for μA78L02, μA78L02AC, μA78L05C, and μA78L05AC and -40°C to 125°C for μA78L05Q and μA78L05AQ.

electrical characteristics at specified virtual junction temperature, $V_I = 10\text{ V}$, $I_O = 40\text{ mA}$ (unless otherwise noted)

PARAMETER	TEST CONDITIONS	T_J †	μA78L05C, μA78L05Q			μA78L05AC, μA78L05AQ			UNIT
			MIN	TYP	MAX	MIN	TYP	MAX	
Output voltage‡	$V_I = 7\text{ V to }20\text{ V}$, $I_O = 1\text{ mA to }40\text{ mA}$ $I_O = 1\text{ mA to }70\text{ mA}$	25°C	4.6	5	5.4	4.8	5	5.2	V
		Full range§	4.5		5.5	4.75		5.25	
			4.5		5.5	4.75		5.25	
Input voltage regulation	$V_I = 7\text{ V to }20\text{ V}$	25°C		32	200		32	150	mV
	$V_I = 8\text{ V to }20\text{ V}$			26	150		26	100	
Ripple rejection	$V_I = 8\text{ V to }18\text{ V}$, $f = 120\text{ Hz}$	25°C	40	49		41	49		dB
Output voltage regulation	$I_O = 1\text{ mA to }100\text{ mA}$	25°C		15	60		15	60	mV
	$I_O = 1\text{ mA to }40\text{ mA}$			8	30		8	30	
Output noise voltage	$f = 10\text{ Hz to }100\text{ kHz}$	25°C		42		42			μV
Dropout voltage		25°C		1.7		1.7			V
Bias current		25°C		3.8	6		3.8	6	mA
		125°C			5.5			5.5	
Bias current change	$V_I = 8\text{ V to }20\text{ V}$ $I_O = 1\text{ mA to }40\text{ mA}$	Full range§			1.5			1.5	mA
					0.2			0.1	

† Pulse-testing techniques maintain T_J as close to T_A as possible. Thermal effects must be taken into account separately. All characteristics are measured with a 0.33-μF capacitor across the input and a 0.1-μF capacitor across the output.

‡ This specification applies only for dc power dissipation permitted by absolute maximum ratings.

§ Full range virtual junction temperature is 0°C to 125°C for μA78L02, μA78L02AC, μA78L05C, and μA78L05AC and -40°C to 125°C for μA78L05Q and μA78L05AQ.



μA78L00 SERIES POSITIVE-VOLTAGE REGULATORS

SLVS010D – JANUARY 1976 – REVISED OCTOBER 1995

electrical characteristics at specified virtual junction temperature, $V_I = 12\text{ V}$, $I_O = 40\text{ mA}$ (unless otherwise noted)

PARAMETER	TEST CONDITIONS	T_J †	μA78L06C			μA78L06AC			UNIT	
			MIN	TYP	MAX	MIN	TYP	MAX		
Output voltage‡	$V_I = 8.5\text{ V to }20\text{ V}$, $I_O = 1\text{ mA to }40\text{ mA}$	25°C	5.7	6.2	6.7	5.95	6.2	6.45	V	
		Full range§		5.6		6.8	5.9			6.5
				5.6		6.8	5.9			6.5
Input voltage regulation	$V_I = 8.5\text{ V to }20\text{ V}$	25°C		35	200		35	175	mV	
	$V_I = 9\text{ V to }20\text{ V}$			29	150		29	125		
Ripple rejection	$V_I = 10\text{ V to }20\text{ V}$, $f = 120\text{ Hz}$	25°C	39	48		40	48		dB	
Output voltage regulation	$I_O = 1\text{ mA to }100\text{ mA}$	25°C		16	80		16	80	mV	
	$I_O = 1\text{ mA to }40\text{ mA}$			9	40		9	40		
Output noise voltage	$f = 10\text{ Hz to }100\text{ kHz}$	25°C		46		46			μV	
Dropout voltage		25°C		1.7		1.7			V	
Bias current		25°C		3.9	6		3.9	6	mA	
		125°C			5.5			5.5		
Bias current change	$V_I = 9\text{ V to }20\text{ V}$, $I_O = 1\text{ mA to }40\text{ mA}$	Full range§			1.5			1.5	mA	
					0.2			0.1		

† Pulse-testing techniques maintain T_J as close to T_A as possible. Thermal effects must be taken into account separately. All characteristics are measured with a 0.33-μF capacitor across the input and a 0.1-μF capacitor across the output.

‡ This specification applies only for dc power dissipation permitted by absolute maximum ratings.

§ Full range virtual junction temperature is 0°C to 125°C for μA78L06C, μA78L06AC, μA78L08C, and μA78L08AC.

electrical characteristics at specified virtual junction temperature, $V_I = 14\text{ V}$, $I_O = 40\text{ mA}$ (unless otherwise noted)

PARAMETER	TEST CONDITIONS	T_J †	μA78L08C			μA78L08AC			UNIT	
			MIN	TYP	MAX	MIN	TYP	MAX		
Output voltage‡	$V_I = 10.5\text{ V to }23\text{ V}$, $I_O = 1\text{ mA to }40\text{ mA}$	25°C	7.36	8	8.64	7.7	8	8.3	V	
		Full range§		7.2		8.8	7.6			8.4
				7.2		8.8	7.6			8.4
Input voltage regulation	$V_I = 10.5\text{ V to }23\text{ V}$	25°C		42	200		42	175	mV	
	$V_I = 11\text{ V to }23\text{ V}$			36	150		36	125		
Ripple rejection	$V_I = 13\text{ V to }23\text{ V}$, $f = 120\text{ Hz}$	25°C	36	46		37	46		dB	
Output voltage regulation	$I_O = 1\text{ mA to }100\text{ mA}$	25°C		18	80		18	80	mV	
	$I_O = 1\text{ mA to }40\text{ mA}$			10	40		10	40		
Output noise voltage	$f = 10\text{ Hz to }100\text{ kHz}$	25°C		54		54			μV	
Dropout voltage		25°C		1.7		1.7			V	
Bias current		25°C		4	6		4	6	mA	
		125°C			5.5			5.5		
Bias current change	$V_I = 5\text{ V to }20\text{ V}$, $I_O = 1\text{ mA to }40\text{ mA}$	Full range§			1.5			1.5	mA	
					0.2			0.1		

† Pulse-testing techniques maintain T_J as close to T_A as possible. Thermal effects must be taken into account separately. All characteristics are measured with a 0.33-μF capacitor across the input and a 0.1-μF capacitor across the output.

‡ This specification applies only for dc power dissipation permitted by absolute maximum ratings.

§ Full range virtual junction temperature is 0°C to 125°C for μA78L06C, μA78L06AC, μA78L08C, and μA78L08AC.



μA78L00 SERIES POSITIVE-VOLTAGE REGULATORS

SLVS010D – JANUARY 1976 – REVISED OCTOBER 1995

electrical characteristics at specified virtual junction temperature, $V_I = 16\text{ V}$, $I_O = 40\text{ mA}$ (unless otherwise noted)

PARAMETER	TEST CONDITIONS	T_J †	μA78L09C			μA78L09AC			UNIT
			MIN	TYP	MAX	MIN	TYP	MAX	
Output voltage‡	$V_I = 12\text{ V to }24\text{ V}$, $I_O = 1\text{ mA to }40\text{ mA}$ $I_O = 1\text{ mA to }70\text{ mA}$	25°C	8.3	9	9.7	8.6	9	9.4	V
		Full range§	8.1		9.9	8.55		9.45	
			8.1		9.9	8.55		9.45	
Input voltage regulation	$V_I = 12\text{ V to }24\text{ V}$	25°C		45	225		45	175	mV
	$V_I = 13\text{ V to }24\text{ V}$			40	175		40	125	
Ripple rejection	$V_I = 15\text{ V to }25\text{ V}$, $f = 120\text{ Hz}$	25°C	36	45		38	45		dB
Output voltage regulation	$I_O = 1\text{ mA to }100\text{ mA}$	25°C		19	90		19	90	mV
	$I_O = 1\text{ mA to }40\text{ mA}$			11	40		11	40	
Output noise voltage	$f = 10\text{ Hz to }100\text{ kHz}$	25°C		58		58			μV
Dropout voltage		25°C		1.7		1.7			V
Bias current		25°C		4.1	6		4.1	6	mA
		125°C			5.5			5.5	
Bias current change	$V_I = 13\text{ V to }24\text{ V}$	Full range§			1.5			1.5	mA
	$I_O = 1\text{ mA to }40\text{ mA}$				0.2			0.1	

† Pulse-testing techniques maintain T_J as close to T_A as possible. Thermal effects must be taken into account separately. All characteristics are measured with a 0.33-μF capacitor across the input and a 0.1-μF capacitor across the output.

‡ This specification applies only for dc power dissipation permitted by absolute maximum ratings.

§ Full range virtual junction temperature is 0°C to 125°C for μA78L09C, μA78L09AC, μA78L10C, and μA78L10AC.

electrical characteristics at specified virtual junction temperature, $V_I = 14\text{ V}$, $I_O = 40\text{ mA}$ (unless otherwise noted)

PARAMETER	TEST CONDITIONS	T_J †	μA78L10C			μA78L10AC			UNIT
			MIN	TYP	MAX	MIN	TYP	MAX	
Output voltage‡	$V_I = 13\text{ V to }25\text{ V}$, $I_O = 1\text{ mA to }40\text{ mA}$ $I_O = 1\text{ mA to }70\text{ mA}$	25°C	9.2	10	10.8	9.6	10	10.4	V
		Full range§	9		11	9.5		10.5	
			9		11	9.5		10.5	
Input voltage regulation	$V_I = 13\text{ V to }25\text{ V}$	25°C		51	225		51	175	mV
	$V_I = 14\text{ V to }25\text{ V}$			42	175		42	125	
Ripple rejection	$V_I = 15\text{ V to }25\text{ V}$, $f = 120\text{ Hz}$	25°C	36	44		37	44		dB
Output voltage regulation	$I_O = 1\text{ mA to }100\text{ mA}$	25°C		20	90		20	90	mV
	$I_O = 1\text{ mA to }40\text{ mA}$			11	40		11	40	
Output noise voltage	$f = 10\text{ Hz to }100\text{ kHz}$	25°C		62		62			μV
Dropout voltage		25°C		1.7		1.7			V
Bias current		25°C		4.2	6		4.2	6	mA
		125°C			5.5			5.5	
Bias current change	$V_I = 14\text{ V to }25\text{ V}$	Full range§			1.5			1.5	mA
	$I_O = 1\text{ mA to }40\text{ mA}$				0.2			0.1	

† Pulse-testing techniques maintain T_J as close to T_A as possible. Thermal effects must be taken into account separately. All characteristics are measured with a 0.33-μF capacitor across the input and a 0.1-μF capacitor across the output.

‡ This specification applies only for dc power dissipation permitted by absolute maximum ratings.

§ Full range virtual junction temperature is 0°C to 125°C for μA78L09C, μA78L09AC, μA78L10C, and μA78L10AC.



μA78L00 SERIES POSITIVE-VOLTAGE REGULATORS

SLVS010D – JANUARY 1976 – REVISED OCTOBER 1995

electrical characteristics at specified virtual junction temperature, $V_I = 19\text{ V}$, $I_O = 40\text{ mA}$ (unless otherwise noted)

PARAMETER	TEST CONDITIONS	T_J †	μA78L12C, μA78L12Q			μA78L12AC, μA78L12AQ			UNIT
			MIN	TYP	MAX	MIN	TYP	MAX	
Output voltage‡		25°C	11.1	12	12.9	11.5	12	12.5	V
	$V_I = 14\text{ V to }27\text{ V}$, $I_O = 1\text{ mA to }40\text{ mA}$	Full range§	10.8		13.2	11.4		12.6	
	$I_O = 1\text{ mA to }70\text{ mA}$		10.8		13.2	11.4		12.6	
Input voltage regulation	$V_I = 14.5\text{ V to }27\text{ V}$	25°C		55	250		55	250	mV
	$V_I = 16\text{ V to }27\text{ V}$			49	200		49	200	
Ripple rejection	$V_I = 15\text{ V to }25\text{ V}$, $f = 120\text{ Hz}$	25°C	36	42		37	42		dB
Output voltage regulation	$I_O = 1\text{ mA to }100\text{ mA}$	25°C		22	100		22	100	mV
	$I_O = 1\text{ mA to }40\text{ mA}$			13	50		13	50	
Output noise voltage	$f = 10\text{ Hz to }100\text{ kHz}$	25°C		70		70			μV
Dropout voltage		25°C		1.7		1.7			V
Bias current		25°C		4.3	6.5		4.3	6.5	mA
		125°C			6			6	
Bias current change	$V_I = 16\text{ V to }27\text{ V}$	Full range§			1.5			1.5	mA
	$I_O = 1\text{ mA to }40\text{ mA}$				0.2			0.1	

† Pulse-testing techniques maintain T_J as close to T_A as possible. Thermal effects must be taken into account separately. All characteristics are measured with a 0.33-μF capacitor across the input and a 0.1-μF capacitor across the output.

‡ This specification applies only for dc power dissipation permitted by absolute maximum ratings.

§ Full range virtual junction temperature is 0°C to 125°C for μA78L12C, μA78L12AC, μA78L15C, and μA78L15AC.

electrical characteristics at specified virtual junction temperature, $V_I = 23\text{ V}$, $I_O = 40\text{ mA}$ (unless otherwise noted)

PARAMETER	TEST CONDITIONS	T_J †	μA78L15C			μA78L15AC			UNIT
			MIN	TYP	MAX	MIN	TYP	MAX	
Output voltage‡		25°C	13.8	15	16.2	14.4	15	15.6	V
	$V_I = 17.5\text{ V to }30\text{ V}$, $I_O = 1\text{ mA to }40\text{ mA}$	Full range§	13.5		16.5	14.25		15.75	
	$I_O = 1\text{ mA to }70\text{ mA}$		13.5		16.5	14.25		15.75	
Input voltage regulation	$V_I = 17.5\text{ V to }30\text{ V}$	25°C		65	300		65	300	mV
	$V_I = 20\text{ V to }30\text{ V}$			58	250		58	250	
Ripple rejection	$V_I = 18.5\text{ V to }28.5\text{ V}$, $f = 120\text{ Hz}$	25°C	33	39		34	39		dB
Output voltage regulation	$I_O = 1\text{ mA to }100\text{ mA}$	25°C		25	150		25	150	mV
	$I_O = 1\text{ mA to }40\text{ mA}$			15	75		15	75	
Output noise voltage	$f = 10\text{ Hz to }100\text{ kHz}$	25°C		82		82			μV
Dropout voltage		25°C		1.7		1.7			V
Bias current		25°C		4.6	6.5		4.6	6.5	mA
		125°C			6			6	
Bias current change	$V_I = 10\text{ V to }30\text{ V}$	Full range§			1.5			1.5	mA
	$I_O = 1\text{ mA to }40\text{ mA}$				0.2			0.1	

† Pulse-testing techniques maintain T_J as close to T_A as possible. Thermal effects must be taken into account separately. All characteristics are measured with a 0.33-μF capacitor across the input and a 0.1-μF capacitor across the output.

‡ This specification applies only for dc power dissipation permitted by absolute maximum ratings.

§ Full range virtual junction temperature is 0°C to 125°C for μA78L12C, μA78L12AC, μA78L15C, and μA78L15AC.



μA78L00 SERIES POSITIVE-VOLTAGE REGULATORS

SLVS010D – JANUARY 1976 – REVISED OCTOBER 1995

electrical characteristics at specified virtual junction temperature, $V_I = 9\text{ V}$, $I_O = 40\text{ mA}$, $T_A = 25^\circ\text{C}$ (unless otherwise noted)

PARAMETER	TEST CONDITIONST	μA78L02Y			UNIT
		MIN	TYP	MAX	
Output voltage [†]			2.6		V
Input voltage regulation	$V_I = 4.75\text{ V to }20\text{ V}$		20		mV
	$V_I = 5\text{ V to }20\text{ V}$		16		
Ripple rejection	$V_I = 6\text{ V to }20\text{ V}$, $f = 120\text{ Hz}$		51		dB
Output voltage regulation	$I_O = 1\text{ mA to }100\text{ mA}$		12		mV
	$I_O = 1\text{ mA to }40\text{ mA}$		6		
Output noise voltage	$f = 10\text{ Hz to }100\text{ kHz}$		30		μV
Dropout voltage			1.7		V
Bias current			3.6		mA

[†] Pulse-testing techniques maintain T_J as close to T_A as possible. Thermal effects must be taken into account separately. All characteristics are measured with a 0.33-μF capacitor across the input and a 0.1-μF capacitor across the output.

[‡] This specification applies only for dc power dissipation permitted by absolute maximum ratings.

electrical characteristics at specified virtual junction temperature, $V_I = 10\text{ V}$, $I_O = 40\text{ mA}$, $T_A = 25^\circ\text{C}$ (unless otherwise noted)

PARAMETER	TEST CONDITIONST	μA78L05Y			UNIT
		MIN	TYP	MAX	
Output voltage [†]			5		V
Input voltage regulation	$V_I = 7\text{ V to }20\text{ V}$		32		mV
	$V_I = 8\text{ V to }20\text{ V}$		26		
Ripple rejection	$V_I = 8\text{ V to }18\text{ V}$, $f = 120\text{ Hz}$		49		dB
Output voltage regulation	$I_O = 1\text{ mA to }100\text{ mA}$		15		mV
	$I_O = 1\text{ mA to }40\text{ mA}$		8		
Output noise voltage	$f = 10\text{ Hz to }100\text{ kHz}$		42		μV
Dropout voltage			1.7		V
Bias current			3.8		mA

[†] Pulse-testing techniques maintain T_J as close to T_A as possible. Thermal effects must be taken into account separately. All characteristics are measured with a 0.33-μF capacitor across the input and a 0.1-μF capacitor across the output.

[‡] This specification applies only for dc power dissipation permitted by absolute maximum ratings.

electrical characteristics at specified virtual junction temperature, $V_I = 12\text{ V}$, $I_O = 40\text{ mA}$, $T_A = 25^\circ\text{C}$ (unless otherwise noted)

PARAMETER	TEST CONDITIONST	μA78L06Y			UNIT
		MIN	TYP	MAX	
Output voltage [†]			6.2		V
Input voltage regulation	$V_I = 8.5\text{ V to }20\text{ V}$		35		mV
	$V_I = 9\text{ V to }20\text{ V}$		29		
Ripple rejection	$V_I = 10\text{ V to }20\text{ V}$, $f = 120\text{ Hz}$		48		dB
Output voltage regulation	$I_O = 1\text{ mA to }100\text{ mA}$		16		mV
	$I_O = 1\text{ mA to }40\text{ mA}$		9		
Output noise voltage	$f = 10\text{ Hz to }100\text{ kHz}$		46		μV
Dropout voltage			1.7		V
Bias current			3.9		mA

[†] Pulse-testing techniques maintain T_J as close to T_A as possible. Thermal effects must be taken into account separately. All characteristics are measured with a 0.33-μF capacitor across the input and a 0.1-μF capacitor across the output.

[‡] This specification applies only for dc power dissipation permitted by absolute maximum ratings.



μA78L00 SERIES POSITIVE-VOLTAGE REGULATORS

SLVS010D – JANUARY 1976 – REVISED OCTOBER 1995

electrical characteristics at specified virtual junction temperature, $V_I = 14\text{ V}$, $I_O = 40\text{ mA}$, $T_A = 25^\circ\text{C}$ (unless otherwise noted)

PARAMETER	TEST CONDITIONST	μA78L08Y			UNIT
		MIN	TYP	MAX	
Output voltage [†]			8		V
Input voltage regulation	$V_I = 10.5\text{ V to }23\text{ V}$		42		mV
	$V_I = 11\text{ V to }23\text{ V}$		36		
Ripple rejection	$V_I = 13\text{ V to }23\text{ V}$, $f = 120\text{ Hz}$		46		dB
Output voltage regulation	$I_O = 1\text{ mA to }100\text{ mA}$		18		mV
	$I_O = 1\text{ mA to }40\text{ mA}$		10		
Output noise voltage	$f = 10\text{ Hz to }100\text{ kHz}$		54		μV
Dropout voltage			1.7		V
Bias current			4		mA

[†] Pulse-testing techniques maintain T_J as close to T_A as possible. Thermal effects must be taken into account separately. All characteristics are measured with a 0.33-μF capacitor across the input and a 0.1-μF capacitor across the output.

[‡] This specification applies only for dc power dissipation permitted by absolute maximum ratings.

electrical characteristics at specified virtual junction temperature, $V_I = 16\text{ V}$, $I_O = 40\text{ mA}$, $T_A = 25^\circ\text{C}$ (unless otherwise noted)

PARAMETER	TEST CONDITIONST	μA78L09Y			UNIT
		MIN	TYP	MAX	
Output voltage [†]			9		V
Input voltage regulation	$V_I = 12\text{ V to }24\text{ V}$		45		mV
	$V_I = 13\text{ V to }24\text{ V}$		40		
Ripple rejection	$V_I = 15\text{ V to }25\text{ V}$, $f = 120\text{ Hz}$		45		dB
Output voltage regulation	$I_O = 1\text{ mA to }100\text{ mA}$		19		mV
	$I_O = 1\text{ mA to }40\text{ mA}$		11		
Output noise voltage	$f = 10\text{ Hz to }100\text{ kHz}$		58		μV
Dropout voltage			1.7		V
Bias current			4.1		mA

[†] Pulse-testing techniques maintain T_J as close to T_A as possible. Thermal effects must be taken into account separately. All characteristics are measured with a 0.33-μF capacitor across the input and a 0.1-μF capacitor across the output.

[‡] This specification applies only for dc power dissipation permitted by absolute maximum ratings.

electrical characteristics at specified virtual junction temperature, $V_I = 14\text{ V}$, $I_O = 40\text{ mA}$, $T_A = 25^\circ\text{C}$ (unless otherwise noted)

PARAMETER	TEST CONDITIONST	μA78L10Y			UNIT
		MIN	TYP	MAX	
Output voltage [†]			10		V
Input voltage regulation	$V_I = 13\text{ V to }25\text{ V}$		51		mV
	$V_I = 14\text{ V to }25\text{ V}$		42		
Ripple rejection	$V_I = 15\text{ V to }25\text{ V}$, $f = 120\text{ Hz}$		44		dB
Output voltage regulation	$I_O = 1\text{ mA to }100\text{ mA}$		20		mV
	$I_O = 1\text{ mA to }40\text{ mA}$		11		
Output noise voltage	$f = 10\text{ Hz to }100\text{ kHz}$		62		μV
Dropout voltage			1.7		V
Bias current			4.2		mA

[†] Pulse-testing techniques maintain T_J as close to T_A as possible. Thermal effects must be taken into account separately. All characteristics are measured with a 0.33-μF capacitor across the input and a 0.1-μF capacitor across the output.

[‡] This specification applies only for dc power dissipation permitted by absolute maximum ratings.



μA78L00 SERIES POSITIVE-VOLTAGE REGULATORS

SLVS010D – JANUARY 1976 – REVISED OCTOBER 1995

electrical characteristics at specified virtual junction temperature, $V_I = 19\text{ V}$, $I_O = 40\text{ mA}$, $T_A = 25^\circ\text{C}$ (unless otherwise noted)

PARAMETER	TEST CONDITIONST	μA78L12Y			UNIT
		MIN	TYP	MAX	
Output voltage [†]			12		V
Input voltage regulation	$V_I = 14.5\text{ V to }27\text{ V}$		55		mV
	$V_I = 16\text{ V to }27\text{ V}$		49		
Ripple rejection	$V_I = 15\text{ V to }25\text{ V}$, $f = 120\text{ Hz}$		42		dB
Output voltage regulation	$I_O = 1\text{ mA to }100\text{ mA}$		22		mV
	$I_O = 1\text{ mA to }40\text{ mA}$		13		
Output noise voltage	$f = 10\text{ Hz to }100\text{ kHz}$		70		μV
Dropout voltage			1.7		V
Bias current			4.3		mA

[†] Pulse-testing techniques maintain T_J as close to T_A as possible. Thermal effects must be taken into account separately. All characteristics are measured with a 0.33-μF capacitor across the input and a 0.1-μF capacitor across the output.

[‡] This specification applies only for dc power dissipation permitted by absolute maximum ratings.

electrical characteristics at specified virtual junction temperature, $V_I = 23\text{ V}$, $I_O = 40\text{ mA}$, $T_A = 25^\circ\text{C}$ (unless otherwise noted)

PARAMETER	TEST CONDITIONST	μA78L15Y			UNIT
		MIN	TYP	MAX	
Output voltage [†]			15		V
Input voltage regulation	$V_I = 17.5\text{ V to }30\text{ V}$		65		mV
	$V_I = 20\text{ V to }30\text{ V}$		58		
Ripple rejection	$V_I = 18.5\text{ V to }28.5\text{ V}$, $f = 120\text{ Hz}$		39		dB
Output voltage regulation	$I_O = 1\text{ mA to }100\text{ mA}$		25		mV
	$I_O = 1\text{ mA to }40\text{ mA}$		15		
Output noise voltage	$f = 10\text{ Hz to }100\text{ kHz}$		82		μV
Dropout voltage			1.7		V
Bias current			4.6		mA

[†] Pulse-testing techniques maintain T_J as close to T_A as possible. Thermal effects must be taken into account separately. All characteristics are measured with a 0.33-μF capacitor across the input and a 0.1-μF capacitor across the output.

[‡] This specification applies only for dc power dissipation permitted by absolute maximum ratings.



APPLICATION INFORMATION

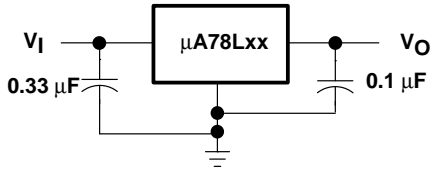

Figure 1. Fixed Output Regulator

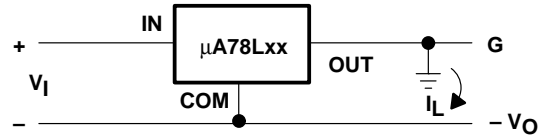

Figure 2. Positive Regulator in Negative Configuration (V_I Must Float)

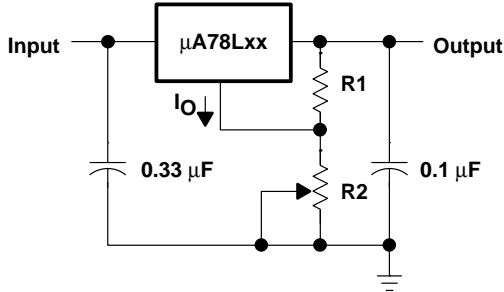

Figure 3. Adjustable Output Regulator

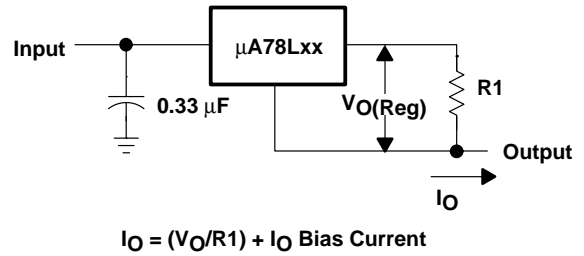

Figure 4. Current Regulator

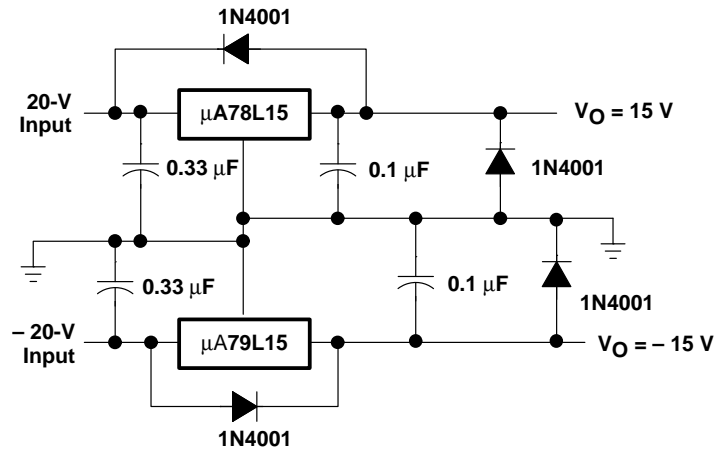

Figure 5. Regulated Dual Supply

μ A78L00 SERIES POSITIVE-VOLTAGE REGULATORS

SLVS010D – JANUARY 1976 – REVISED OCTOBER 1995

APPLICATION INFORMATION

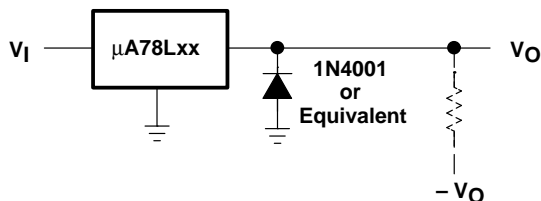

Figure 6. Output Polarity-Reversal Protection Circuit

operation with a load common to a voltage of opposite polarity

In many cases, a regulator powers a load that is not connected to ground but instead is connected to a voltage source of opposite polarity (e.g., operational amplifiers, level-shifting circuits, etc.). In these cases, a clamp diode should be connected to the regulator output as shown in Figure 6. This protects the regulator from output polarity reversals during startup and short-circuit operation.

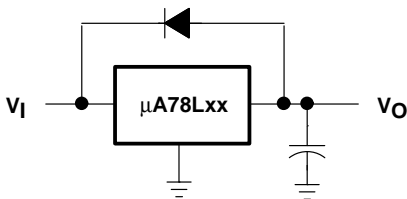

Figure 7. Reverse-Bias Protection Circuit

reverse-bias protection

Occasionally, there exists the possibility that the input voltage to the regulator can collapse faster than the output voltage. This could occur, for example, when the input supply is crowbarred during an output overvoltage condition. If the output voltage is greater than approximately 7 V, the emitter-base junction of the series pass element (internal or external) could break down and be damaged. To prevent this, a diode shunt can be employed as shown in Figure 7.

IMPORTANT NOTICE

Texas Instruments (TI) reserves the right to make changes to its products or to discontinue any semiconductor product or service without notice, and advises its customers to obtain the latest version of relevant information to verify, before placing orders, that the information being relied on is current.

TI warrants performance of its semiconductor products and related software to the specifications applicable at the time of sale in accordance with TI's standard warranty. Testing and other quality control techniques are utilized to the extent TI deems necessary to support this warranty. Specific testing of all parameters of each device is not necessarily performed, except those mandated by government requirements.

Certain applications using semiconductor products may involve potential risks of death, personal injury, or severe property or environmental damage ("Critical Applications").

TI SEMICONDUCTOR PRODUCTS ARE NOT DESIGNED, INTENDED, AUTHORIZED, OR WARRANTED TO BE SUITABLE FOR USE IN LIFE-SUPPORT APPLICATIONS, DEVICES OR SYSTEMS OR OTHER CRITICAL APPLICATIONS.

Inclusion of TI products in such applications is understood to be fully at the risk of the customer. Use of TI products in such applications requires the written approval of an appropriate TI officer. Questions concerning potential risk applications should be directed to TI through a local SC sales office.

In order to minimize risks associated with the customer's applications, adequate design and operating safeguards should be provided by the customer to minimize inherent or procedural hazards.

TI assumes no liability for applications assistance, customer product design, software performance, or infringement of patents or services described herein. Nor does TI warrant or represent that any license, either express or implied, is granted under any patent right, copyright, mask work right, or other intellectual property right of TI covering or relating to any combination, machine, or process in which such semiconductor products or services might be or are used.