

DALLAS SEMICONDUCTOR

DS9098 iButton™ Retainer

FEATURES

- Compact single-piece, all-metal receptacle for iButton mounting
- Retainer withstands high temperatures required for surface mounting
- Center contact is permanently separated at first insertion of the iButton
- Material is stainless steel with selective tin-lead plating for optimal solderability to printed circuit board
- Retainer to iButton connection is stainless steel to stainless steel
- Quadruple redundancy of contacts (4 plus 4)
- Contact force exceeds 200 grams for reliable connection
- At insertion, the iButton is latched for retention
- Pops up for removal when latch is released
- Gentle deflection of latches allows removal of the iButton
- >25 insertion/withdrawal cycles with no performance degradation
- Compatible with standard pick and place equipment; insensitive to angular orientation
- Cleaning fluids drain freely for quick clean up
- Available in bulk packaging (DS9098) or in extruded tube packaging (DS9098T)

DESCRIPTION

The DS9098 iButton Retainer is a low-cost, surface mount device that retains a 16.3mm x 5.8mm MicroCan on a printed circuit board. The slender design secures the iButton for a compact printed circuit board mount. The retainer latches the flange of the iButton and prevents reversed insertion.

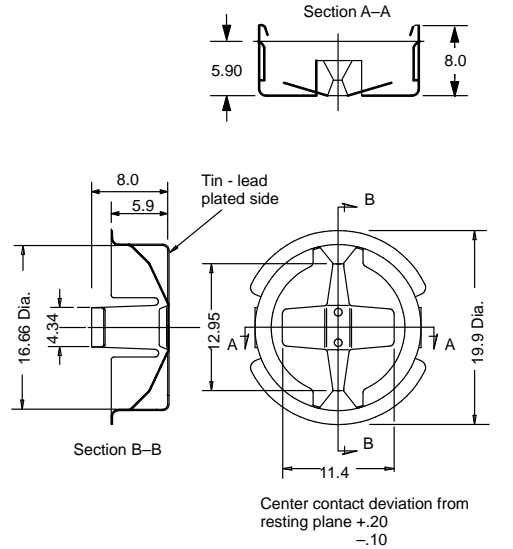

Recommended Printed Circuit Layout Pads

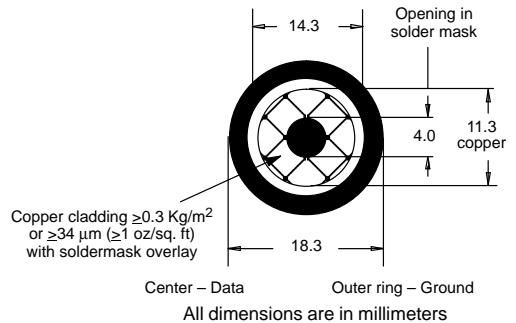

PRECAUTIONS ON USE

At first insertion closely align axis of the iButton and the Retainer, and then apply approximately 10 kg force for the separation of the center contacts. At subsequent insertion maintain similar axial alignment to avoid permanent deformation. At removal, limit deflection of retainer latches to just free the iButton edge from retained state. Avoid applying excess force to latches.