

## NAME

B - The Perl Compiler

## SYNOPSIS

```
use B;
```

## DESCRIPTION

The `B` module supplies classes which allow a Perl program to delve into its own innards. It is the module used to implement the "backends" of the Perl compiler. Usage of the compiler does not require knowledge of this module: see the `O` module for the user-visible part. The `B` module is of use to those who want to write new compiler backends. This documentation assumes that the reader knows a fair amount about perl's internals including such things as SVs, OPs and the internal symbol table and syntax tree of a program.

## OVERVIEW

The `B` module contains a set of utility functions for querying the current state of the Perl interpreter; typically these functions return objects from the `B::SV` and `B::OP` classes, or their derived classes. These classes in turn define methods for querying the resulting objects about their own internal state.

## Utility Functions

The `B` module exports a variety of functions: some are simple utility functions, others provide a Perl program with a way to get an initial "handle" on an internal object.

## Functions Returning `B::SV`, `B::AV`, `B::HV`, and `B::CV` objects

For descriptions of the class hierarchy of these objects and the methods that can be called on them, see below, *OVERVIEW OF CLASSES* and *SV-RELATED CLASSES*.

`sv_undef`

Returns the SV object corresponding to the C variable `sv_undef`.

`sv_yes`

Returns the SV object corresponding to the C variable `sv_yes`.

`sv_no`

Returns the SV object corresponding to the C variable `sv_no`.

`svref_2object(SVREF)`

Takes a reference to any Perl value, and turns the referred-to value into an object in the appropriate `B::OP`-derived or `B::SV`-derived class. Apart from functions such as `main_root`, this is the primary way to get an initial "handle" on an internal perl data structure which can then be followed with the other access methods.

The returned object will only be valid as long as the underlying OPs and SVs continue to exist. Do not attempt to use the object after the underlying structures are freed.

`amagic_generation`

Returns the SV object corresponding to the C variable `amagic_generation`.

`init_av`

Returns the AV object (i.e. in class `B::AV`) representing INIT blocks.

`check_av`

Returns the AV object (i.e. in class `B::AV`) representing CHECK blocks.

`unitcheck_av`

Returns the AV object (i.e. in class `B::AV`) representing UNITCHECK blocks.

`begin_av`

Returns the AV object (i.e. in class `B::AV`) representing BEGIN blocks.

`end_av`

Returns the AV object (i.e. in class `B::AV`) representing END blocks.

`comppadlist`

Returns the AV object (i.e. in class `B::AV`) of the global `comppadlist`.

`regex_padav`

Only when perl was compiled with `ithreads`.

`main_cv`

Return the (faked) CV corresponding to the main part of the Perl program.

### Functions for Examining the Symbol Table

`walksymtable(SYMREF, METHOD, RECURSE, PREFIX)`

Walk the symbol table starting at `SYMREF` and call `METHOD` on each symbol (a `B::GV` object) visited. When the walk reaches package symbols (such as `"Foo::"`) it invokes `RECURSE`, passing in the symbol name, and only recurses into the package if that sub returns true.

`PREFIX` is the name of the `SYMREF` you're walking.

For example:

```
# Walk CGI's symbol table calling print_subs on each symbol.
# Recurse only into CGI::Util::
walksymtable(\%CGI::, 'print_subs', sub { $_[0] eq 'CGI::Util::' },
             'CGI::');
```

`print_subs()` is a `B::GV` method you have declared. Also see *B::GV Methods*, below.

### Functions Returning B::OP objects or for walking op trees

For descriptions of the class hierarchy of these objects and the methods that can be called on them, see below, *OVERVIEW OF CLASSES* and *OP-RELATED CLASSES*.

`main_root`

Returns the root op (i.e. an object in the appropriate `B::OP`-derived class) of the main part of the Perl program.

`main_start`

Returns the starting op of the main part of the Perl program.

`walkoptree(OP, METHOD)`

Does a tree-walk of the syntax tree based at `OP` and calls `METHOD` on each op it visits. Each node is visited before its children. If `walkoptree_debug` (see below) has been called to turn debugging on then the method `walkoptree_debug` is called on each op before `METHOD` is called.

`walkoptree_debug(DEBUG)`

Returns the current debugging flag for `walkoptree`. If the optional `DEBUG` argument is non-zero, it sets the debugging flag to that. See the description of `walkoptree` above for what the debugging flag does.

## Miscellaneous Utility Functions

`ppname(OPNUM)`

Return the PP function name (e.g. "pp\_add") of op number OPNUM.

`hash(STR)`

Returns a string in the form "0x..." representing the value of the internal hash function used by perl on string STR.

`cast_I32(I)`

Casts I to the internal I32 type used by that perl.

`minus_c`

Does the equivalent of the `-c` command-line option. Obviously, this is only useful in a BEGIN block or else the flag is set too late.

`cstring(STR)`

Returns a double-quote-surrounded escaped version of STR which can be used as a string in C source code.

`perlstring(STR)`

Returns a double-quote-surrounded escaped version of STR which can be used as a string in Perl source code.

`class(OBJ)`

Returns the class of an object without the part of the classname preceding the first " : : ". This is used to turn "B::UNOP" into "UNOP" for example.

`threadsv_names`

In a perl compiled for threads, this returns a list of the special per-thread threadsv variables.

## Exported utility variables

`@optype`

```
my $op_type = $optype[$op_type_num];
```

A simple mapping of the op type number to its type (like 'COP' or 'BINOP').

`@specialsv_name`

```
my $sv_name = $specialsv_name[$sv_index];
```

Certain SV types are considered 'special'. They're represented by B::SPECIAL and are referred to by a number from the specialsv\_list. This array maps that number back to the name of the SV (like 'Nullsv' or '&PL\_sv\_undef').

## OVERVIEW OF CLASSES

The C structures used by Perl's internals to hold SV and OP information (PVIV, AV, HV, ..., OP, SVOP, UNOP, ...) are modelled on a class hierarchy and the B module gives access to them via a true object hierarchy. Structure fields which point to other objects (whether types of SV or types of OP) are represented by the B module as Perl objects of the appropriate class.

The bulk of the B module is the methods for accessing fields of these structures.

Note that all access is read-only. You cannot modify the internals by using this module. Also, note that the B::OP and B::SV objects created by this module are only valid for as long as the underlying objects exist; their creation doesn't increase the reference counts of the underlying objects. Trying to access the fields of a freed object will give incomprehensible results, or worse.

## SV-RELATED CLASSES

B::IV, B::NV, B::RV, B::PV, B::PVIV, B::PVNV, B::PVMG, B::BM (5.9.5 and earlier), B::PVLV, B::AV, B::HV, B::CV, B::GV, B::FM, B::IO. These classes correspond in the obvious way to the underlying C structures of similar names. The inheritance hierarchy mimics the underlying C "inheritance". For 5.9.5 and later this is:

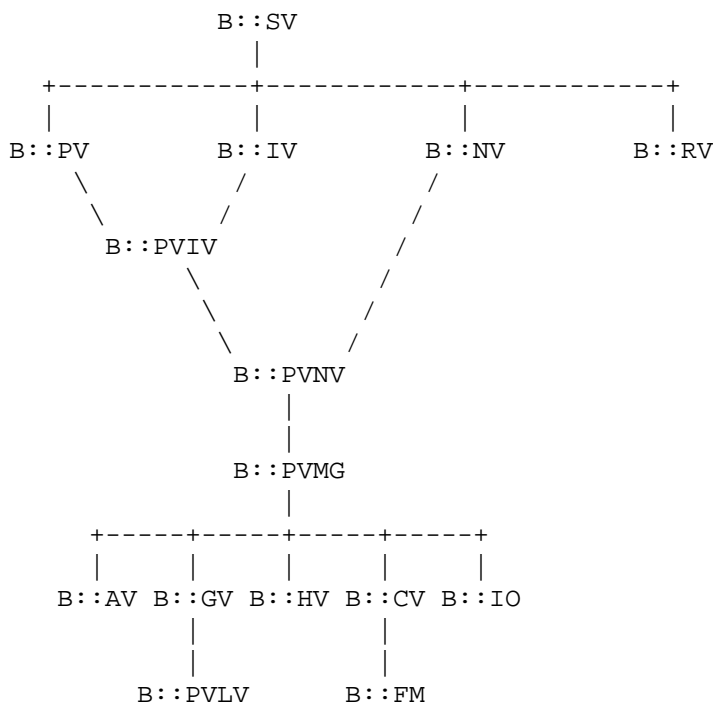

For 5.9.0 and earlier, PVLV is a direct subclass of PVMG, and BM is still present as a distinct type, so the base of this diagram is

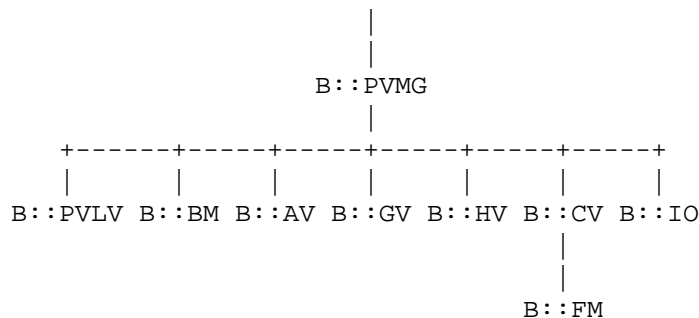

Access methods correspond to the underlying C macros for field access, usually with the leading "class indication" prefix removed (Sv, Av, Hv, ...). The leading prefix is only left in cases where its removal would cause a clash in method name. For example, GvREFCNT stays as-is since its abbreviation would clash with the "superclass" method REF CNT (corresponding to the C function SvREFCNT).

### B::SV Methods

REFCNT  
 FLAGS  
 object\_2svref

Returns a reference to the regular scalar corresponding to this B::SV object. In other words, this method is the inverse operation to the svref\_2object() subroutine. This scalar and other

data it points at should be considered read-only: modifying them is neither safe nor guaranteed to have a sensible effect.

### B::IV Methods

IV

Returns the value of the IV, *interpreted as a signed integer*. This will be misleading if `FLAGS` & `Svf_IVisUV`. Perhaps you want the `int_value` method instead?

IVX

UVX

`int_value`

This method returns the value of the IV as an integer. It differs from `IV` in that it returns the correct value regardless of whether it's stored signed or unsigned.

`needs64bits`

`packiv`

### B::NV Methods

NV

NVX

### B::RV Methods

RV

### B::PV Methods

PV

This method is the one you usually want. It constructs a string using the length and offset information in the struct: for ordinary scalars it will return the string that you'd see from Perl, even if it contains null characters.

RV

Same as `B::RV::RV`, except that it will `die()` if the PV isn't a reference.

PVX

This method is less often useful. It assumes that the string stored in the struct is null-terminated, and disregards the length information.

It is the appropriate method to use if you need to get the name of a lexical variable from a padname array. Lexical variable names are always stored with a null terminator, and the length field (`SvCUR`) is overloaded for other purposes and can't be relied on here.

### B::PVMG Methods

MAGIC

`SvSTASH`

### B::MAGIC Methods

MOREMAGIC

`precomp`

Only valid on r-magic, returns the string that generated the regexp.

PRIVATE

TYPE

FLAGS

OBJ

Will die() if called on r-magic.

PTR

REGEX

Only valid on r-magic, returns the integer value of the REGEX stored in the MAGIC.

### B::PVLV Methods

TARGOFF

TARGLEN

TYPE

TARG

### B::BM Methods

USEFUL

PREVIOUS

RARE

TABLE

### B::GV Methods

is\_empty

This method returns TRUE if the GP field of the GV is NULL.

NAME

SAFENAME

This method returns the name of the glob, but if the first character of the name is a control character, then it converts it to ^X first, so that `*^G` would return `"^G"` rather than `"\cG"`.

It's useful if you want to print out the name of a variable. If you restrict yourself to globs which exist at compile-time then the result ought to be unambiguous, because code like `$_ = *` is compiled as two ops - a constant string and a dereference (`rv2gv`) - so that the glob is created at runtime.

If you're working with globs at runtime, and need to disambiguate `*^G` from `*{"^G"}`, then you should use the raw `NAME` method.

STASH

SV

IO

FORM

AV

HV

EGV

CV

CVGEN

LINE

FILE

FILEGV

GvREFCNT

FLAGS

**B::IO Methods**

LINES  
PAGE  
PAGE\_LEN  
LINES\_LEFT  
TOP\_NAME  
TOP\_GV  
FMT\_NAME  
FMT\_GV  
BOTTOM\_NAME  
BOTTOM\_GV  
SUBPROCESS  
IoTYPE  
IoFLAGS  
IsSTD

Takes one arguments ( 'stdin' | 'stdout' | 'stderr' ) and returns true if the IoIFP of the object is equal to the handle whose name was passed as argument ( i.e. \$io->IsSTD('stderr') is true if IoIFP(\$io) == PerlIO\_stdin() ).

**B::AV Methods**

FILL  
MAX  
ARRAY  
ARRAYelt

Like `ARRAY`, but takes an index as an argument to get only one element, rather than a list of all of them.

OFF

This method is deprecated if running under Perl 5.8, and is no longer present if running under Perl 5.9

AvFLAGS

This method returns the AV specific flags. In Perl 5.9 these are now stored in with the main SV flags, so this method is no longer present.

**B::CV Methods**

STASH  
START  
ROOT  
GV  
FILE  
DEPTH  
PADLIST  
OUTSIDE  
OUTSIDE\_SEQ  
XSUB

**XSUBANY**

For constant subroutines, returns the constant SV returned by the subroutine.

**CvFLAGS**

const\_sv

**B::HV Methods**

FILL

MAX

KEYS

RITER

NAME

ARRAY

PMROOT

This method is not present if running under Perl 5.9, as the PMROOT information is no longer stored directly in the hash.

**OP-RELATED CLASSES**

B::OP, B::UNOP, B::BINOP, B::LOGOP, B::LISTOP, B::PMOP, B::SVOP, B::PADOP, B::PVOP, B::LOOP, B::COP.

These classes correspond in the obvious way to the underlying C structures of similar names. The inheritance hierarchy mimics the underlying C "inheritance":

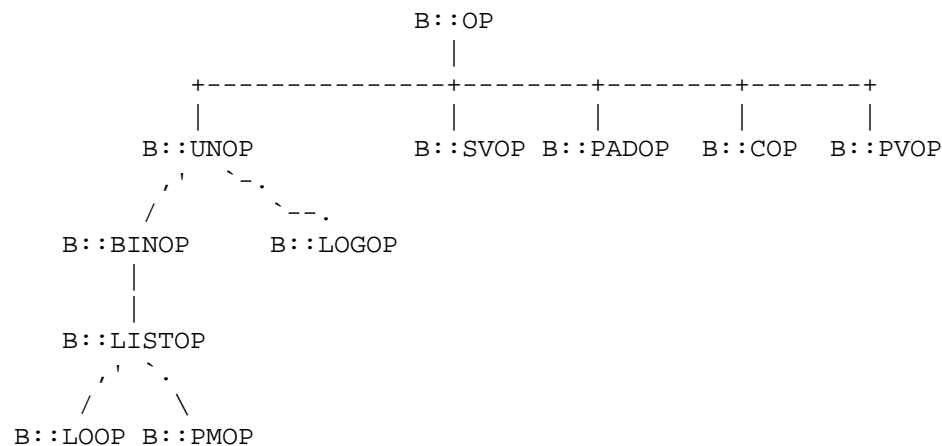

Access methods correspond to the underlying C structure field names, with the leading "class indication" prefix ("op\_") removed.

**B::OP Methods**

These methods get the values of similarly named fields within the OP data structure. See top of `op.h` for more info.

next

sibling

name

This returns the op name as a string (e.g. "add", "rv2av").

ppaddr

This returns the function name as a string (e.g. "PL\_ppaddr[OP\_ADD]"),



desc "PL\_ppaddr[OP\_RV2AV]").

This returns the op description from the global C PL\_op\_desc array (e.g. "addition" "array deref").

targ

type

opt

flags

private

spare

#### **B::UNOP METHOD**

first

#### **B::BINOP METHOD**

last

#### **B::LOGOP METHOD**

other

#### **B::LISTOP METHOD**

children

#### **B::PMOP Methods**

pmreplroot

pmreplstart

pmnext

pmregexp

pmflags

extflags

precomp

pmoffset

Only when perl was compiled with ithreads.

#### **B::SVOP METHOD**

sv

gv

#### **B::PADOP METHOD**

padix

#### **B::PVOP METHOD**

pv

#### **B::LOOP Methods**

redoop

nextop

lastop

**B::COP Methods**

- label
- stash
- stashpv
- file
- cop\_seq
- arybase
- line
- warnings
- io
- hints
- hints\_hash

**AUTHOR**

Malcolm Beattie, [mbeattie@sable.ox.ac.uk](mailto:mbeattie@sable.ox.ac.uk)